



# MEASUREMENT REPORT

## FCC Part 15B

---

**FCC ID:** XR3-KEPLER

**APPLICANT:** ONYX INTERNATIONAL INC.

**Application Type:** Certification

**Product:** E-reader

**Model No.:** Kepler, Kepler Pro, Kepler Lite, Da Vinci, ONYX BOOX  
MONTE CRISTO, ONYX BOOX ROBINSON CRUSOE

**FCC Classification:** FCC Class B Digital Device (JBP)

**FCC Rule Part(s):** FCC Part 15 Subpart B: 2016

**Test Procedure(s):** ANSI C63.4: 2014

**Test Date:** June 17 ~ July 13, 2016

Reviewed By : Robin Wu  
( Robin Wu )

Approved By : Marlin Chen  
( Marlin Chen )



The test results relate only to the samples tested.

This equipment has been shown to be capable of compliance with the applicable technical standards as indicated in the measurement report and was tested in accordance with the measurement procedures specified in ANSI C63.4-2014. Test results reported herein relate only to the item(s) tested.

The test report shall not be reproduced except in full without the written approval of MRT Technology (Suzhou) Co., Ltd.

---

## Revision History

| Report No.   | Version | Description         | Issue Date |
|--------------|---------|---------------------|------------|
| 1606RSU02004 | Rev. 01 | Initial report      | 08-05-2016 |
| 1606RSU02004 | Rev. 02 | Added serial number | 08-09-2016 |
|              |         |                     |            |

# CONTENTS

| Description   | Page      |
|---|-----------|
| <b>§2.1033 General Information .....</b>                  | <b>4</b>  |
| <b>1. INTRODUCTION .....</b>                              | <b>5</b>  |
| 1.1. Scope .....  | 5         |
| 1.2. MRT Test Location.....                               | 5         |
| <b>2. PRODUCT INFORMATION .....</b>                       | <b>6</b>  |
| 2.1. Product Specification Subjective to this Report..... | 6         |
| 2.2. Test Mode .....                                      | 6         |
| 2.3. Test Configuration .....                             | 7         |
| 2.4. Test System Details.....                             | 9         |
| 2.5. Test Software .....                                  | 9         |
| 2.6. EMI Suppression Device(s)/Modifications.....         | 9         |
| <b>3. DESCRIPTION OF TEST .....</b>                       | <b>10</b> |
| 3.1. Evaluation Procedure .....                           | 10        |
| 3.2. AC Line Conducted Emissions .....                    | 10        |
| 3.3. Radiated Emissions .....                             | 11        |
| <b>4. TEST EQUIPMENT CALIBRATION DATE .....</b>           | <b>12</b> |
| <b>5. MEASUREMENT UNCERTAINTY .....</b>                   | <b>13</b> |
| <b>6. TEST RESULT .....</b>                               | <b>14</b> |
| 6.1. Summary .....  | 14        |
| 6.2. Conducted Emission Measurement .....                 | 15        |
| 6.2.1. Test Limit .....                                   | 15        |
| 6.2.2. Test Setup.....                                    | 15        |
| 6.2.3. Test Result of Conducted Emissions.....            | 16        |
| 6.3. Radiated Emission Measurement .....                  | 20        |
| 6.3.1. Test Limit .....                                   | 20        |
| 6.3.2. Test Setup.....                                    | 20        |
| 6.3.3. Test Result of Radiated Emissions.....             | 22        |

## §2.1033 General Information

|                                  |   |
|----------------------------------|---|
| <b>Applicant:</b>                | ONYX INTERNATIONAL INC.   |
| <b>Applicant Address:</b>        | Room 102, 3rd Floor, No. 38 HongLou Road, LiWan District, GuangZhou, China  |
| <b>Manufacturer:</b>             | ONYX INTERNATIONAL INC.   |
| <b>Manufacturer Address:</b>     | Room 102, 3rd Floor, No. 38 HongLou Road, LiWan District, GuangZhou, China  |
| <b>Test Site:</b>                | MRT Technology (Suzhou) Co., Ltd  |
| <b>Test Site Address:</b>        | D8 Building, Youxin Industrial Park, No.2 Tian'edang Rd., Wuzhong Economic Development Zone, Suzhou, China                      |
| <b>MRT FCC Registration No.:</b> | 809388  |
| <b>FCC ID:</b>                   | XR3-KEPLER  |
| <b>Model No.:</b>                | Kepler, Kepler Pro, Kepler Lite, Da Vinci, ONYX BOOX MONTE CRISTO, ONYX BOOX ROBINSON CRUSOE                                    |
| <b>Test Device Serial No.:</b>   | N/A <input type="checkbox"/> Production <input checked="" type="checkbox"/> Pre-Production <input type="checkbox"/> Engineering |

### Test Facility / Accreditations

Measurements were performed at MRT Laboratory located in Tian'edang Rd., Suzhou, China.

- MRT facility is a FCC registered (MRT Reg. No. 809388) test facility with the site description report on file and has met all the requirements specified in Section 2.948 of the FCC Rules.
- MRT facility is an IC registered (MRT Reg. No. 11384A-1) test laboratory with the site description on file at Industry Canada.
- MRT facility is a VCCI registered (R-4179, G-814, C-4664, T-2206) test laboratory with the site description on file at VCCI Council.
- MRT Lab is accredited to ISO 17025 by the American Association for Laboratory Accreditation (A2LA) under the American Association for Laboratory Accreditation Program (A2LA Cert. No. 3628.01) in EMC, Telecommunications and Radio testing for FCC, Industry Canada, EU and TELEC Rules.



# 1. INTRODUCTION

## 1.1. Scope

Measurement and determination of electromagnetic emissions (EMC) of radio frequency devices including intentional and/or unintentional radiators for compliance with the technical rules and regulations of the Federal Communications Commission and the Industry Canada Certification and Engineering Bureau.

## 1.2. MRT Test Location

The map below shows the location of the MRT LABORATORY, its proximity to the Taihu Lake. These measurement tests were conducted at the MRT Technology (Suzhou) Co., Ltd. Facility located at D8 Building, Youxin Industrial Park, No.2 Tian'edang Rd., Wuzhong Economic Development Zone, Suzhou, China. The detailed description of the measurement facility was found to be in compliance with the requirements of § 2.948 according to ANSI C63.4-2009 on September 30, 2013.



## 2. PRODUCT INFORMATION

### 2.1. Product Specification Subjective to this Report

|                     |  |
|---------------------|--|
| Product Name        | E-reader   |
| Model No.           | Kepler, Kepler Pro, Kepler Lite, Da Vinci, ONYX BOOX MONTE CRISTO, ONYX BOOX ROBINSON CRUSOE |
| Wi-Fi Specification | 802.11b/g/n-HT20   |
| Bluetooth Version   | v3.0 + HS, v4.0  |
| <b>Components</b>   |  |
| Adapter             | M/N: HKC0055010-2D<br>INPUT: 100-240V ~ 50/60Hz, 0.2A<br>OUTPUT: 5Vdc, 1.0A                  |

### 2.2. Test Mode

|                            |
|----------------------------|
| Mode 1: Charging + Reading |
| Mode 2: USB Copy           |

### 2.3. Test Configuration

The EUT was tested per the guidance FCC Part 15 Subpart B: 2016 and ANSI C63.4: 2014 was used to reference the appropriate EUT setup for radiated spurious emissions testing and AC line conducted testing.

Connection Diagram (Mode 1)

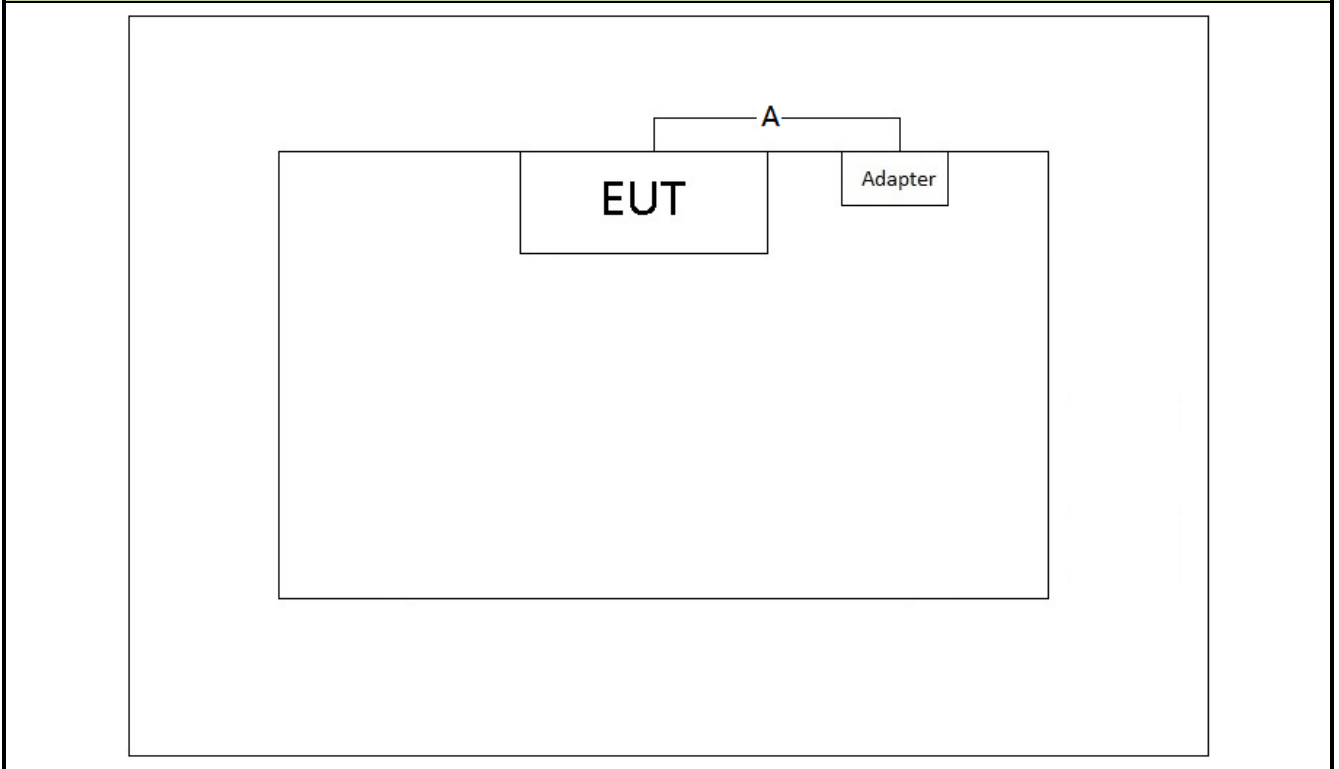

Connection Diagram (Mode 2)

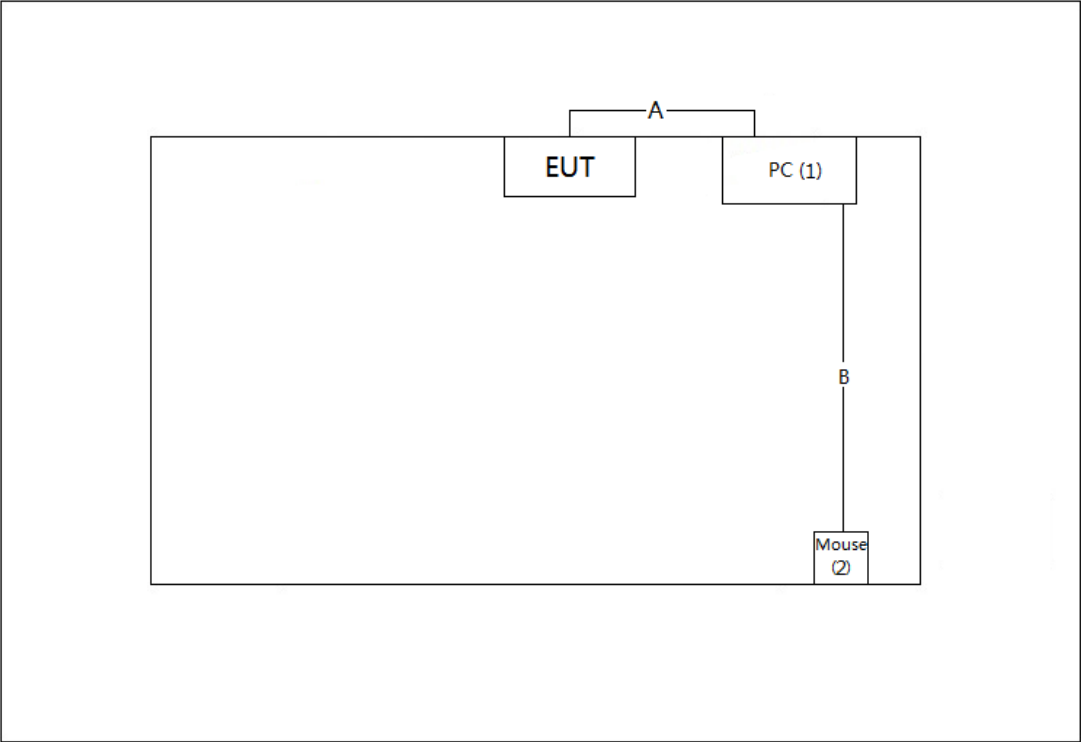

| Signal Cable Type |           | Signal Cable Description |
|-------------------|-----------|--------------------------|
| A                 | USB Cable | Shielded, 0.5m           |
| B                 | USB Cable | Shielded, 1.8m           |



## 2.4. Test System Details

The types for all equipments, plus descriptions of all cables used in the tested system (including inserted cards) are:

| Product | Manufacturer | Model No. | Serial No. | Power Cord    |                    |
|---------|--------------|-----------|------------|---------------|--------------------|
| 1       | Notebook     | Lenovo    | E430c      | MP-4CFX213/10 | Non-Shielded, 1.8m |
| 2       | USB Mouse    | DELL      | MS111-T    | N/A           | N/A                |

## 2.5. Test Software

|   |  |
|---|--|
| 1 | Setup the EUT and simulators as shown on above.  |
| 2 | Turn on the power of all equipment.  |
| 3 | (1), Making EUT working on "Charging + Reading" Mode.<br>(2), Making EUT working on "USB Copy" Mode. |

## 2.6. EMI Suppression Device(s)/Modifications

No EMI suppression device(s) were added and/or no modifications were made during testing.

### 3. DESCRIPTION OF TEST

#### 3.1. Evaluation Procedure

The measurement procedures described in the American National Standard for Methods of Measurement of Radio-Noise Emission from Low-Voltage Electrical Equipment in the Range of 9kHz to 40GHz (ANSI C63.4-2014) was used in the measurement of the **E-reader**

**Deviation from measurement procedure.....None**

#### 3.2. AC Line Conducted Emissions

The line-conducted facility is located inside an 8'x4'x4' shielded enclosure. A 1m x 2m wooden table 80cm high is placed 40cm away from the vertical wall and 80cm away from the sidewall of the shielded room. Two 10kHz-30MHz, 50Ω/50uH Line-Impedance Stabilization Networks (LISNs) are bonded to the shielded room floor. Power to the LISNs is filtered by external high-current high-insertion loss power line filters. These filters attenuate ambient signal noise from entering the measurement lines. These filters are also bonded to the shielded enclosure.

The EUT is powered from one LISN and the support equipment is powered from the second LISN. If the EUT is a DC-powered device, power will be derived from the source power supply it normally will be powered from and this supply line(s) will be connected to the second LISN. All interconnecting cables more than 1 meter were shortened to a 1 meter length by non-inductive bundling (serpentine fashion) and draped over the back edge of the test table. All cables were at least 40cm above the horizontal reference ground-plane. Power cables for support equipment were routed down to the second LISN while ensuring that that cables were not draped over the second LISN.

Sufficient time for the EUT, support equipment, and test equipment was allowed in order for them to warm up to their normal operating condition. The RF output of the LISN was connected to the receiver and exploratory measurements were made to determine the frequencies producing the maximum emission from the EUT. The receiver was scanned from 150 kHz to 30 MHz. The detector function was set to peak mode for exploratory measurements while the bandwidth of the analyzer was set to 9 kHz. The EUT, support equipment, and interconnecting cables were arranged and manipulated to maximize each emission. Each emission was also maximized by varying: power lines, the mode of operation or resolution, clock or data exchange speed, scrolling H pattern to the EUT and/or support equipment whichever determined the worst-case emission. Once the worst case emissions have been identified, the one EUT cable configuration/arrangement and mode of operation that produced these emissions are used for final measurements on the same test site. Line conducted emissions test results are shown in Section 6.2.

### 3.3. Radiated Emissions

The radiated test facilities consisted of an indoor 3 meter semi-anechoic chamber used for final measurements and exploratory measurements, when necessary. The measurement area is contained within the semi-anechoic chamber which is shielded from any ambient interference. For measurements above 1GHz absorbers are arranged on the floor between the turn table and the antenna mast in such a way so as to maximize the reduction of reflections. For measurements below 1GHz, the absorbers are removed. An MF Model 210SS turntable is used for radiated measurement. It is a continuously rotatable, remote controlled, metallic turntable and 2 meters (6.56 ft.) in diameter. The turn table is flush with the raised floor of the chamber in order to maintain its function as a ground plane. An 80cm high PVC support structure is placed on top of the turntable.

For all measurements, the spectrum was scanned through all EUT azimuths and from 1 to 4 meter receive antenna height using a broadband antenna from 30 MHz up to the upper frequency shown in 15.33(b)(1) depending on the highest frequency generated or used in the device or on which the device operates or tunes. For frequencies above 1GHz, linearly polarized double ridge horn antennas were used. For frequencies below 30 MHz, a calibrated loop antenna was used. When exploratory measurements were necessary, they were performed at 1 meter test distance inside the semi-anechoic chamber using broadband antennas, broadband amplifiers, and spectrum analyzers to determine the frequencies and modes producing the maximum emissions. Sufficient time for the EUT, support equipment, and test equipment was allowed in order for them to warm up to their normal operating condition. The test set-up was placed on top of the 0.8 meter high, 1 x 1.5 meter table. The EUT, support equipment, and interconnecting cables were arranged and manipulated to maximize each emission. Appropriate precaution was taken to ensure that all emissions from the EUT were maximized and investigated. The system configuration, mode of operation, if applicable, turntable azimuth, and receive antenna height was noted for each frequency found.

Final measurements were made in the semi-anechoic chamber using calibrated, linearly polarized broadband and horn antennas. The test setup was configured to the setup that produced the worst case emissions. The spectrum analyzer was set to investigate all frequencies required for testing to compare the highest radiated disturbances with respect to the specified limits. The turntable containing the EUT was rotated through 360 degrees and the height of the receive antenna was varied 1 to 4 meters and stopped at the azimuth and height producing the maximum emission. Each emission was maximized by changing the orientation of the EUT through three orthogonal planes and changing the polarity of the receive antenna, whichever produced the worst-case emissions. According to 3dB beam-width of horn antenna, the horn antenna should be always directed to the EUT when rising height.

#### 4. TEST EQUIPMENT CALIBRATION DATE

##### Conducted Emissions – SR2

| Instrument                 | Manufacturer | Type No. | Serial No.  | Cali. Interval | Cali. Due Date |
|----------------------------|--------------|----------|-------------|----------------|----------------|
| EMI Test Receiver          | R&S          | ESR7     | 101209      | 1 year         | 2016/11/03     |
| Two-Line V-Network         | R&S          | ENV216   | 101683      | 1 year         | 2016/11/03     |
| Two-Line V-Network         | R&S          | ENV216   | 101684      | 1 year         | 2016/11/03     |
| Temperature/Humidity Meter | Yuhuaze      | HTC-2    | MRTSUE06182 | 1 year         | 2016/12/20     |

##### Radiated Emission – AC2

| Instrument                      | Manufacturer | Type No.  | Serial No.  | Cali. Interval | Cali. Due Date |
|---------------------------------|--------------|-----------|-------------|----------------|----------------|
| MXE EMI Receiver                | Agilent      | N9038A    | MY51210182  | 1 year         | 2016/08/03     |
| Microwave System Amplifier      | Agilent      | 83017A    | MY53270040  | 1 year         | 2017/03/29     |
| TRILOG Antenna                  | Schwarzbeck  | VULB9162  | 9162-047    | 1 year         | 2016/11/07     |
| Broad-Band Horn Antenna         | Schwarzbeck  | BBHA9120D | 9120D-1167  | 1 year         | 2016/11/07     |
| Digital Thermometer & Hygromete | MingGao      | ETH529    | MRTSUE06170 | 1 year         | 2016/11/30     |

| Software | Version | Function          |
|----------|---------|-------------------|
| e3       | V8.3.5  | EMI Test Software |

## 5. MEASUREMENT UNCERTAINTY

Where relevant, the following test uncertainty levels have been estimated for tests performed on the EUT as specified in CISPR 16-4-2. This uncertainty represents an expanded uncertainty expressed at approximately the 95% confidence level using a coverage factor of  $k = 2$ .

|  |
|--|
| <b>AC Conducted Emission Measurement – SR2</b>   |
| Measuring Uncertainty for a Level of Confidence of 95% ( $U=2Uc(y)$ ):<br>150kHz~30MHz: 3.5dB  |
| <b>Radiated Emission Measurement – AC2</b>   |
| Measuring Uncertainty for a Level of Confidence of 95% ( $U=2Uc(y)$ ):<br>Horizontal: 30MHz~1GHz: 4.07dB<br>1GHz~18GHz: 4.16 dB<br>Vertical:    30MHz~1GHz: 4.18 dB<br>1GHz~18GHz: 4.76 dB |

## 6. TEST RESULT

### 6.1. Summary

Company Name: ONYX INTERNATIONAL INC.

Test Mode: Mode 1: Charging + Reading

Mode 2: USB Copy

| FCC Part Section(s) | Test Description    | Test Result |
|---------------------|---------------------|-------------|
| 15.107              | Conducted Emissions | Pass        |
| 15.109              | Radiated Emissions  | Pass        |

## 6.2. Conducted Emission Measurement

### 6.2.1. Test Limit

| FCC Part 15.107 Limits |                 |                 |
|------------------------|-----------------|-----------------|
| Frequency (MHz)        | QP (dB $\mu$ V) | AV (dB $\mu$ V) |
| 0.15 - 0.50            | 66 - 56         | 56 - 46         |
| 0.50 - 5.0             | 56              | 46              |
| 5.0 - 30               | 60              | 50              |

Note 1: The lower limit shall apply at the transition frequencies.

Note 2: The limit decreases linearly with the logarithm of the frequency in the range 0.15MHz to 0.5MHz.

### 6.2.2. Test Setup

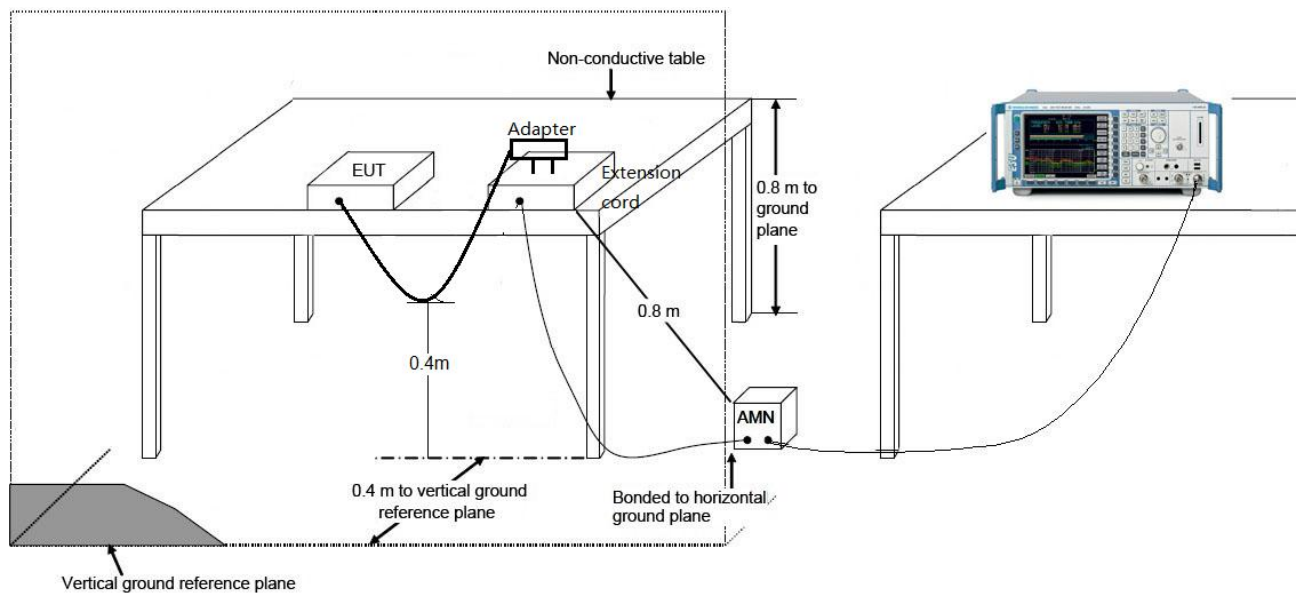

### 6.2.3. Test Result of Conducted Emissions

|                                  |                          |
|----------------------------------|--------------------------|
| Site: SR2                        | Time: 2016/06/21 - 11:35 |
| Limit: FCC_Part15.107_CE_Class B | Engineer: Line Chen      |
| Probe: ENV216_101683_Filter On   | Polarity: Line           |
| EUT: E-reader                    | Power: AC 120V/60Hz      |
| Test Mode 1                      |                          |

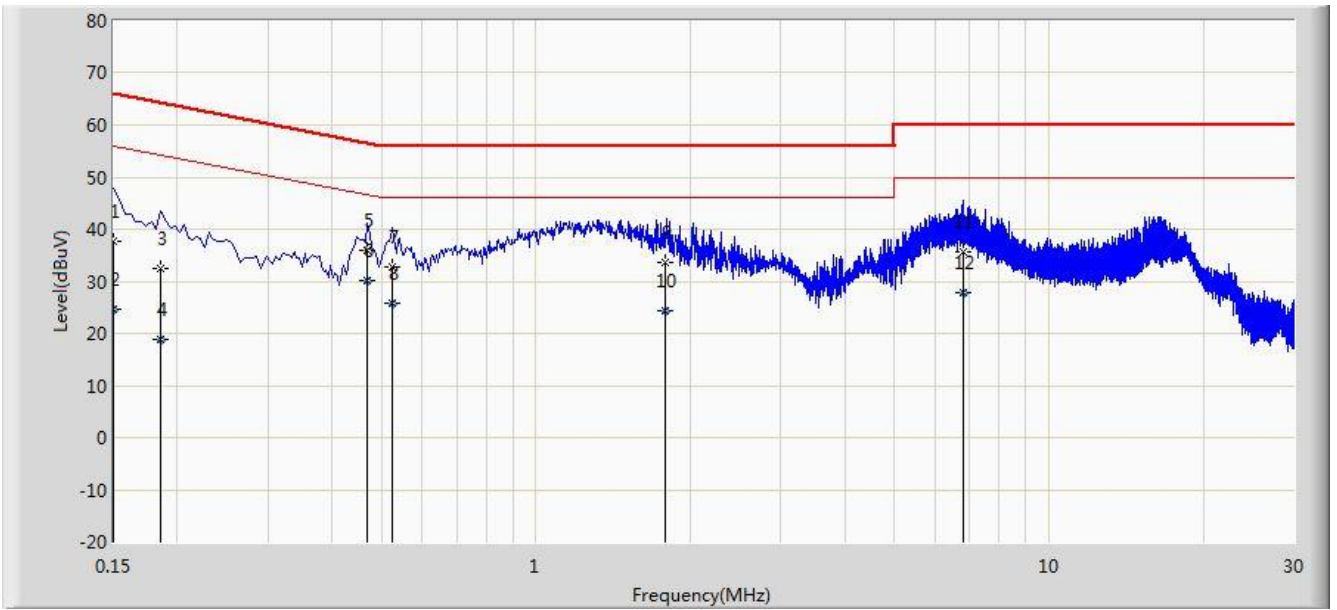

| No | Flag | Mark | Frequency (MHz) | Measure Level (dBuV) | Reading Level (dBuV) | Over Limit (dB) | Limit (dBuV) | Factor (dB) | Type |
|----|------|------|-----------------|----------------------|----------------------|-----------------|--------------|-------------|------|
| 1  |      |      | 0.150           | 37.617               | 26.448               | -28.383         | 66.000       | 11.168      | QP   |
| 2  |      |      | 0.150           | 24.613               | 13.444               | -31.387         | 56.000       | 11.168      | AV   |
| 3  |      |      | 0.186           | 32.369               | 22.331               | -31.844         | 64.213       | 10.039      | QP   |
| 4  |      |      | 0.186           | 18.762               | 8.723                | -35.452         | 54.213       | 10.039      | AV   |
| 5  |      |      | 0.470           | 35.887               | 25.745               | -20.627         | 56.514       | 10.142      | QP   |
| 6  |      | *    | 0.470           | 30.219               | 20.077               | -16.295         | 46.514       | 10.142      | AV   |
| 7  |      |      | 0.525           | 32.820               | 22.667               | -23.180         | 56.000       | 10.153      | QP   |
| 8  |      |      | 0.525           | 25.779               | 15.626               | -20.221         | 46.000       | 10.153      | AV   |
| 9  |      |      | 1.780           | 33.545               | 23.667               | -22.455         | 56.000       | 9.879       | QP   |
| 10 |      |      | 1.780           | 24.401               | 14.522               | -21.599         | 46.000       | 9.879       | AV   |
| 11 |      |      | 6.816           | 35.742               | 25.592               | -24.258         | 60.000       | 10.150      | QP   |
| 12 |      |      | 6.816           | 27.818               | 17.668               | -22.182         | 50.000       | 10.150      | AV   |

Note: Measure Level (dB $\mu$ V) = Reading Level (dB $\mu$ V) + Factor (dB)

Factor (dB) = Cable Loss (dB) + LISN Factor (dB).



|                                    |                          |
|------------------------------------|--------------------------|
| Site: SR2                          | Time: 2016/06/21 - 11:42 |
| Limit: FCC_Part15.107_CE _ Class B | Engineer: Line Chen      |
| Probe: ENV216_101683_Filter On     | Polarity: Neutral        |
| EUT: E-reader                      | Power: AC 120V/60Hz      |
| Test Mode 1                        |                          |

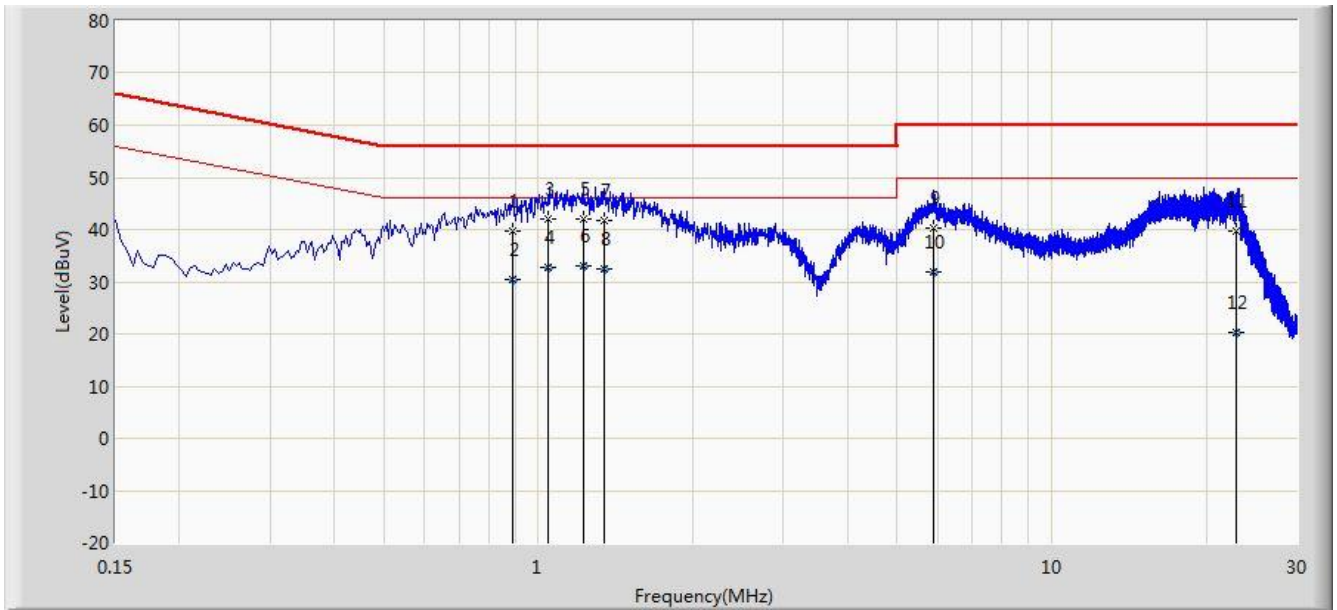

| No | Flag | Mark | Frequency (MHz) | Measure Level (dBuV) | Reading Level (dBuV) | Over Limit (dB) | Limit (dBuV) | Factor (dB) | Type |
|----|------|------|-----------------|----------------------|----------------------|-----------------|--------------|-------------|------|
| 1  |      |      | 0.890           | 39.624               | 29.654               | -16.376         | 56.000       | 9.970       | QP   |
| 2  |      |      | 0.890           | 30.575               | 20.606               | -15.425         | 46.000       | 9.970       | AV   |
| 3  |      |      | 1.046           | 42.012               | 32.105               | -13.988         | 56.000       | 9.907       | QP   |
| 4  |      |      | 1.046           | 32.614               | 22.706               | -13.386         | 46.000       | 9.907       | AV   |
| 5  |      |      | 1.222           | 41.905               | 32.004               | -14.095         | 56.000       | 9.901       | QP   |
| 6  |      | *    | 1.222           | 32.914               | 23.013               | -13.086         | 46.000       | 9.901       | AV   |
| 7  |      |      | 1.343           | 41.751               | 31.854               | -14.249         | 56.000       | 9.897       | QP   |
| 8  |      |      | 1.343           | 32.575               | 22.679               | -13.425         | 46.000       | 9.897       | AV   |
| 9  |      |      | 5.881           | 40.354               | 30.242               | -19.646         | 60.000       | 10.112      | QP   |
| 10 |      |      | 5.881           | 31.747               | 21.635               | -18.253         | 50.000       | 10.112      | AV   |
| 11 |      |      | 22.900          | 39.712               | 29.466               | -20.288         | 60.000       | 10.246      | QP   |
| 12 |      |      | 22.900          | 20.401               | 10.154               | -29.599         | 50.000       | 10.246      | AV   |

Note: Measure Level (dBμV) = Reading Level (dBμV) + Factor (dB)

Factor (dB) = Cable Loss (dB) + LISN Factor (dB).

|                                  |                          |
|----------------------------------|--------------------------|
| Site: SR2                        | Time: 2016/06/21 - 19:23 |
| Limit: FCC_Part15.107_CE_Class B | Engineer: Line Chen      |
| Probe: ENV216_101683_Filter On   | Polarity: Line           |
| EUT: E-reader                    | Power: AC 120V/60Hz      |
| Test Mode 2                      |                          |

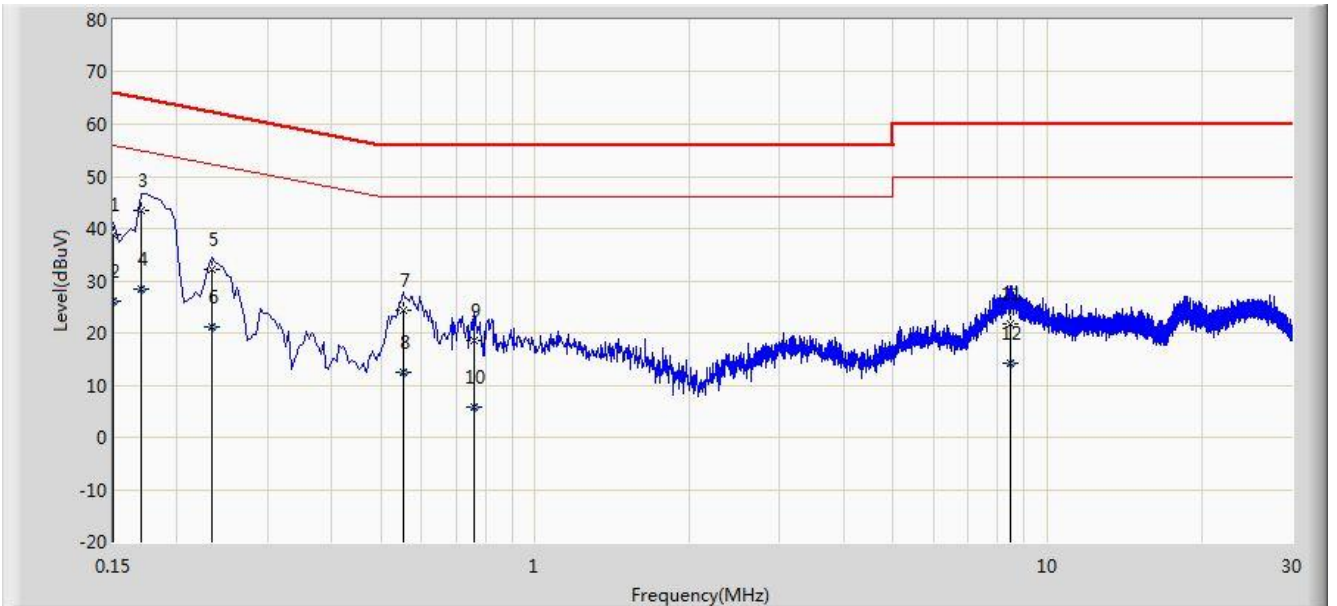

| No | Flag | Mark | Frequency (MHz) | Measure Level (dBuV) | Reading Level (dBuV) | Over Limit (dB) | Limit (dBuV) | Factor (dB) | Type |
|----|------|------|-----------------|----------------------|----------------------|-----------------|--------------|-------------|------|
| 1  |      |      | 0.150           | 38.696               | 27.527               | -27.304         | 66.000       | 11.168      | QP   |
| 2  |      |      | 0.150           | 26.110               | 14.941               | -29.890         | 56.000       | 11.168      | AV   |
| 3  |      | *    | 0.170           | 43.446               | 33.369               | -21.514         | 64.960       | 10.078      | QP   |
| 4  |      |      | 0.170           | 28.377               | 18.300               | -26.583         | 54.960       | 10.078      | AV   |
| 5  |      |      | 0.234           | 32.264               | 22.313               | -30.043         | 62.307       | 9.951       | QP   |
| 6  |      |      | 0.234           | 21.052               | 11.101               | -31.255         | 52.307       | 9.951       | AV   |
| 7  |      |      | 0.554           | 24.452               | 14.314               | -31.548         | 56.000       | 10.139      | QP   |
| 8  |      |      | 0.554           | 12.567               | 2.428                | -33.433         | 46.000       | 10.139      | AV   |
| 9  |      |      | 0.762           | 18.410               | 8.379                | -37.590         | 56.000       | 10.031      | QP   |
| 10 |      |      | 0.762           | 5.671                | -4.360               | -40.329         | 46.000       | 10.031      | AV   |
| 11 |      |      | 8.446           | 21.845               | 11.669               | -38.155         | 60.000       | 10.176      | QP   |
| 12 |      |      | 8.446           | 14.270               | 4.094                | -35.730         | 50.000       | 10.176      | AV   |

Note: Measure Level (dBμV) = Reading Level (dBμV) + Factor (dB)

Factor (dB) = Cable Loss (dB) + LISN Factor (dB).

|                                    |                          |
|------------------------------------|--------------------------|
| Site: SR2                          | Time: 2016/06/21 - 20:11 |
| Limit: FCC_Part15.107_CE _ Class B | Engineer: Line Chen      |
| Probe: ENV216_101683_Filter On     | Polarity: Neutral        |
| EUT: E-reader                      | Power: AC 120V/60Hz      |
| Test Mode 2                        |                          |

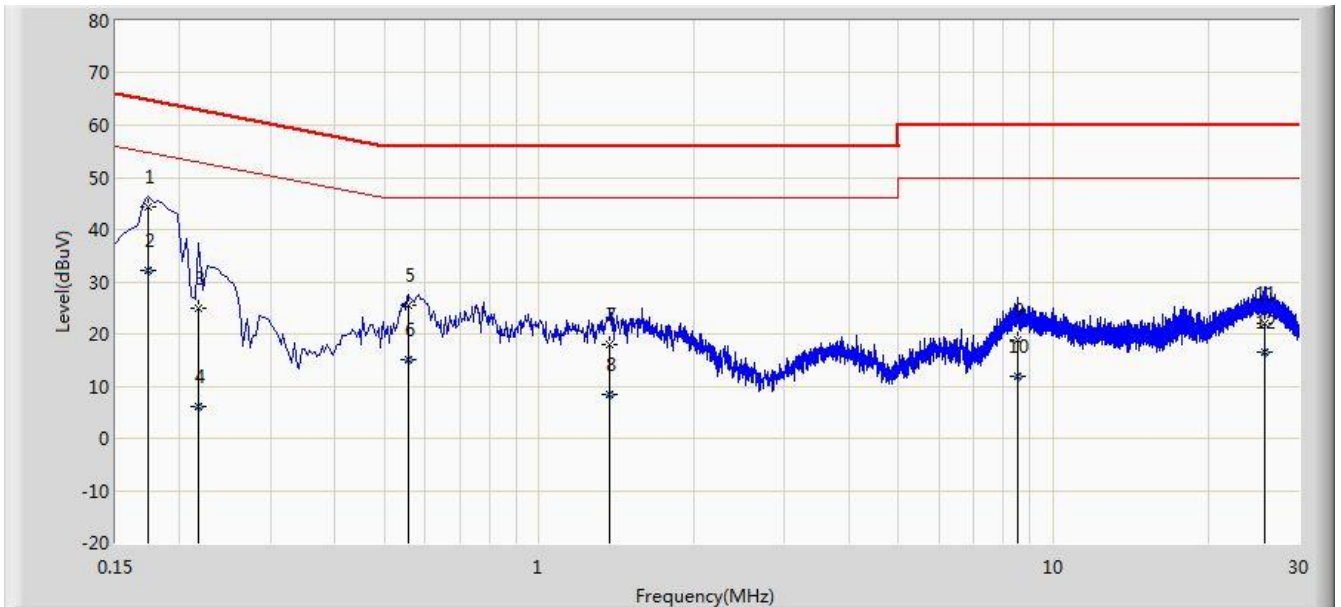

| No | Flag | Mark | Frequency (MHz) | Measure Level (dBuV) | Reading Level (dBuV) | Over Limit (dB) | Limit (dBuV) | Factor (dB) | Type |
|----|------|------|-----------------|----------------------|----------------------|-----------------|--------------|-------------|------|
| 1  |      | *    | 0.174           | 44.377               | 34.321               | -20.390         | 64.767       | 10.057      | QP   |
| 2  |      |      | 0.174           | 32.261               | 22.205               | -22.506         | 54.767       | 10.057      | AV   |
| 3  |      |      | 0.218           | 24.925               | 14.944               | -37.970         | 62.895       | 9.981       | QP   |
| 4  |      |      | 0.218           | 6.071                | -3.911               | -46.824         | 52.895       | 9.981       | AV   |
| 5  |      |      | 0.558           | 25.535               | 15.381               | -30.465         | 56.000       | 10.154      | QP   |
| 6  |      |      | 0.558           | 15.005               | 4.851                | -30.995         | 46.000       | 10.154      | AV   |
| 7  |      |      | 1.370           | 18.040               | 8.145                | -37.960         | 56.000       | 9.895       | QP   |
| 8  |      |      | 1.370           | 8.446                | -1.449               | -37.554         | 46.000       | 9.895       | AV   |
| 9  |      |      | 8.518           | 18.869               | 8.669                | -41.131         | 60.000       | 10.199      | QP   |
| 10 |      |      | 8.518           | 11.788               | 1.589                | -38.212         | 50.000       | 10.199      | AV   |
| 11 |      |      | 25.762          | 22.095               | 11.780               | -37.905         | 60.000       | 10.316      | QP   |
| 12 |      |      | 25.762          | 16.446               | 6.131                | -33.554         | 50.000       | 10.316      | AV   |

Note: Measure Level (dBμV) = Reading Level (dBμV) + Factor (dB)

Factor (dB) = Cable Loss (dB) + LISN Factor (dB).

### 6.3. Radiated Emission Measurement

#### 6.3.1. Test Limit

| FCC Part 15.109 Limits |              |                      |
|------------------------|--------------|----------------------|
| Frequency (MHz)        | Distance (m) | Level (dB $\mu$ V/m) |
| 30 - 88                | 3            | 40                   |
| 88 - 216               | 3            | 43.5                 |
| 216 - 960              | 3            | 46                   |
| Above 960              | 3            | 54                   |

Note 1: The lower limit shall apply at the transition frequency.

Note 2: Distance refers to the distance in meters between the measuring instrument antenna and the closed point of any part of the device or system.

Note 3: E field strength (dB $\mu$ V/m) = 20 log E field strength (uV/m)

#### 6.3.2. Test Setup

30MHz ~ 1GHz Test Setup:

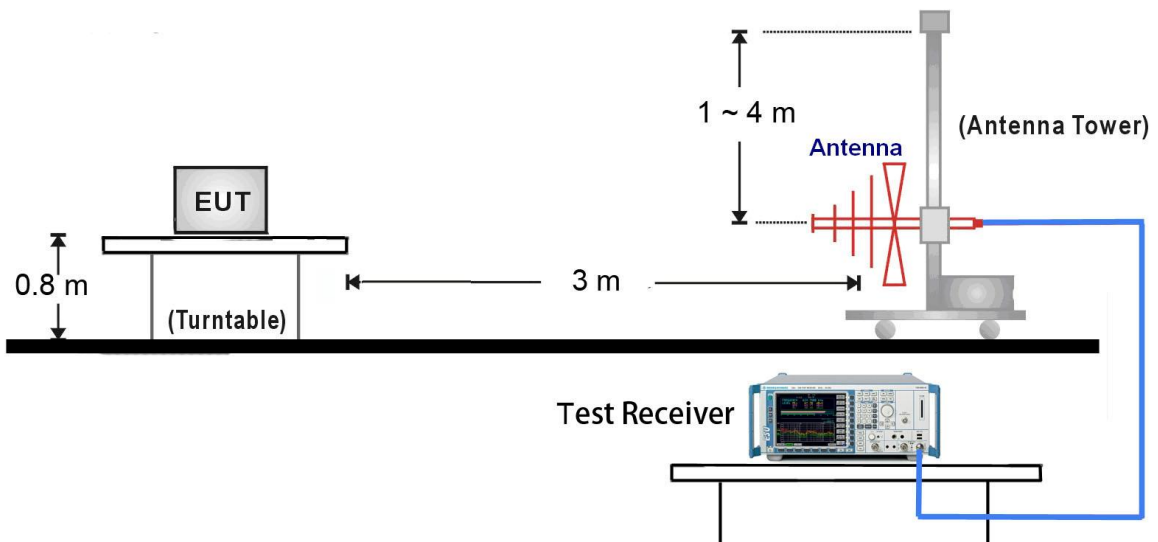

1GHz ~18GHz Test Setup:

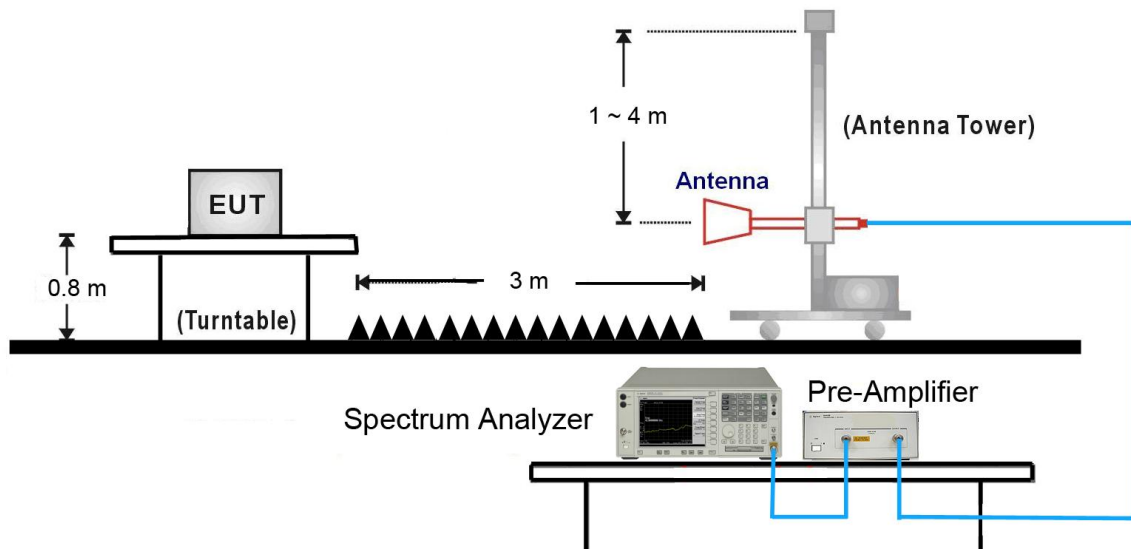

### 6.3.3. Test Result of Radiated Emissions

|                                      |                          |
|--------------------------------------|--------------------------|
| Site: AC2                            | Time: 2016/07/12 - 16:50 |
| Limit: FCC_Part15.109_RE(3m)_Class B | Engineer: Line Chen      |
| Probe: VULB9162_0.03-8GHz            | Polarity: Horizontal     |
| EUT: E-reader                        | Power: AC 120V/60Hz      |
| Test Mode 1                          |                          |

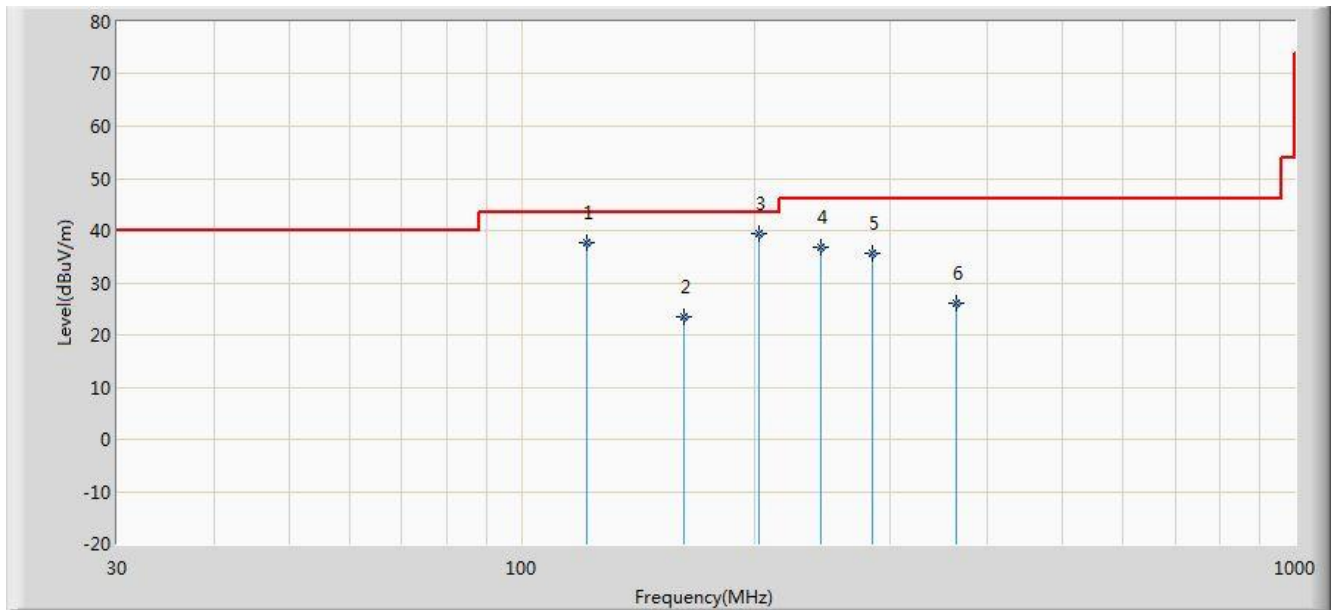

| No | Flag | Mark | Frequency (MHz) | Measure Level (dBuV/m) | Reading Level (dBuV) | Over Limit (dB) | Limit (dBuV/m) | Factor (dB) | Ant Pos (cm) | Table Pos (deg) | Type |
|----|------|------|-----------------|------------------------|----------------------|-----------------|----------------|-------------|--------------|-----------------|------|
| 1  |      |      | 121.665         | 37.591                 | 26.552               | -5.909          | 43.500         | 11.039      | 100          | 78              | QP   |
| 2  |      |      | 162.405         | 23.605                 | 13.667               | -19.895         | 43.500         | 9.938       | 100          | 114             | QP   |
| 3  |      | *    | 203.145         | 39.448                 | 27.116               | -4.052          | 43.500         | 12.333      | 100          | 167             | QP   |
| 4  |      |      | 243.400         | 36.861                 | 23.337               | -9.139          | 46.000         | 13.524      | 100          | 303             | QP   |
| 5  |      |      | 284.140         | 35.656                 | 21.392               | -10.344         | 46.000         | 14.264      | 100          | 46              | QP   |
| 6  |      |      | 365.630         | 26.032                 | 9.936                | -19.968         | 46.000         | 16.096      | 100          | 204             | QP   |

Note: Measure Level (dBuV/m) = Reading Level (dBuV) + Factor (dB)

Factor (dB) = Cable Loss (dB) + Antenna Factor (dB/m).

|                                      |                          |
|--------------------------------------|--------------------------|
| Site: AC2                            | Time: 2016/07/12 - 16:50 |
| Limit: FCC_Part15.109_RE(3m)_Class B | Engineer: Line Chen      |
| Probe: VULB9162_0.03-8GHz            | Polarity: Vertical       |
| EUT: E-reader                        | Power: AC 120V/60Hz      |
| Test Mode 1                          |                          |

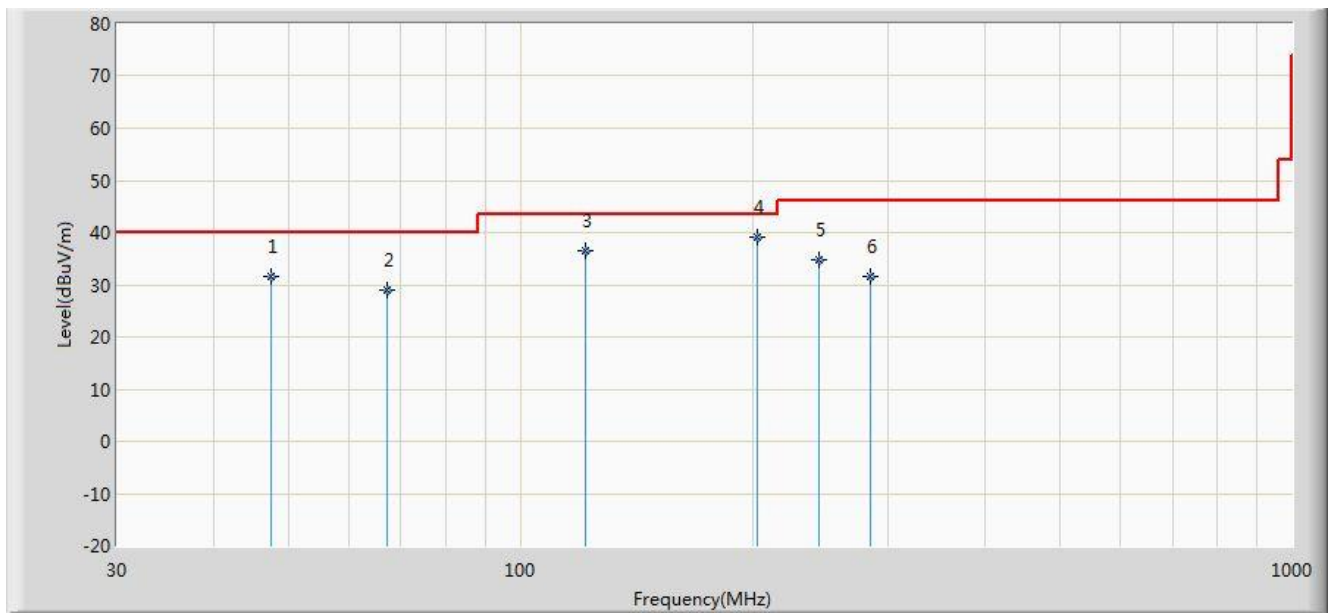

| No | Flag | Mark | Frequency (MHz) | Measure Level (dBuV/m) | Reading Level (dBuV) | Over Limit (dB) | Limit (dBuV/m) | Factor (dB) | Ant Pos (cm) | Table Pos (deg) | Type |
|----|------|------|-----------------|------------------------|----------------------|-----------------|----------------|-------------|--------------|-----------------|------|
| 1  |      |      | 47.460          | 31.602                 | 16.632               | -8.398          | 40.000         | 14.969      | 100          | 32              | QP   |
| 2  |      |      | 67.345          | 29.096                 | 17.331               | -10.904         | 40.000         | 11.765      | 100          | 223             | QP   |
| 3  |      |      | 121.665         | 36.571                 | 25.532               | -6.929          | 43.500         | 11.039      | 100          | 80              | QP   |
| 4  |      | *    | 203.145         | 38.993                 | 26.661               | -4.507          | 43.500         | 12.333      | 100          | 163             | QP   |
| 5  |      |      | 243.400         | 34.641                 | 21.117               | -11.359         | 46.000         | 13.524      | 100          | 310             | QP   |
| 6  |      |      | 284.140         | 31.525                 | 17.261               | -14.475         | 46.000         | 14.264      | 100          | 51              | QP   |

Note: Measure Level (dB $\mu$ V/m) = Reading Level (dB $\mu$ V) + Factor (dB)

Factor (dB) = Cable Loss (dB) + Antenna Factor (dB/m).

|                                      |                          |
|--------------------------------------|--------------------------|
| Site: AC2                            | Time: 2016/07/12 - 16:50 |
| Limit: FCC_Part15.109_RE(3m)_Class B | Engineer: Line Chen      |
| Probe: VULB9162_0.03-8GHz            | Polarity: Horizontal     |
| EUT: E-reader                        | Power: AC 120V/60Hz      |
| Test Mode 2                          |                          |

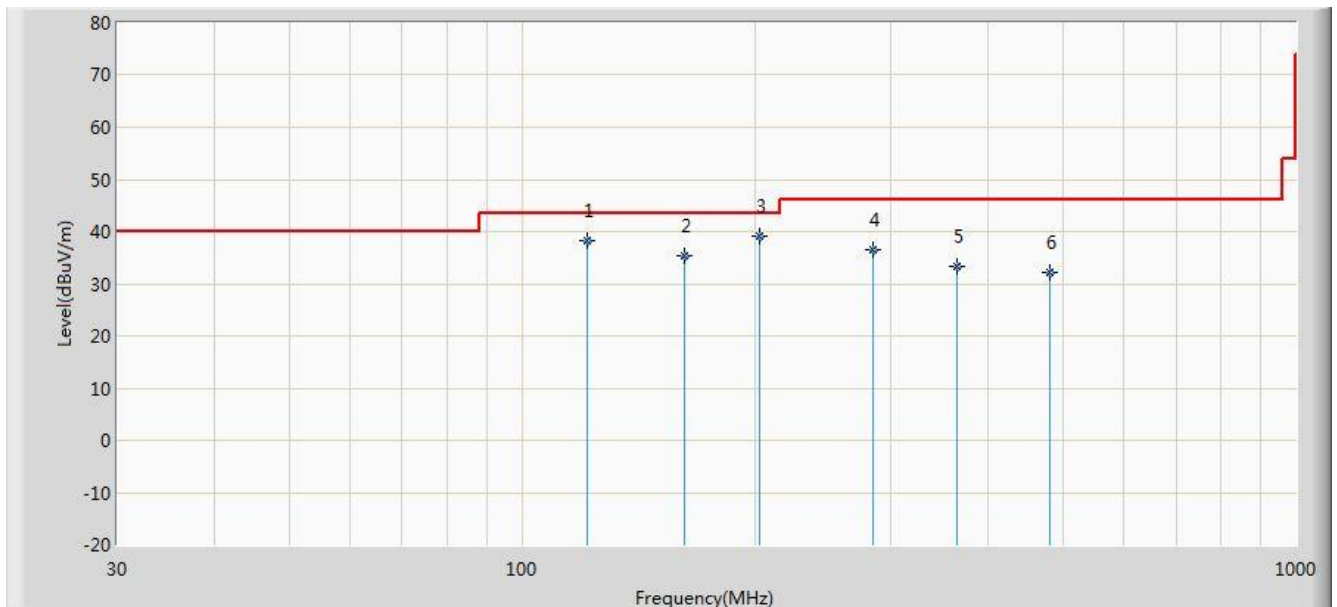

| No | Flag | Mark | Frequency (MHz) | Measure Level (dBuV/m) | Reading Level (dBuV) | Over Limit (dB) | Limit (dBuV/m) | Factor (dB) | Ant Pos (cm) | Table Pos (deg) | Type |
|----|------|------|-----------------|------------------------|----------------------|-----------------|----------------|-------------|--------------|-----------------|------|
| 1  |      |      | 121.665         | 38.155                 | 27.116               | -5.345          | 43.500         | 11.039      | 100          | 82              | QP   |
| 2  |      |      | 162.405         | 35.470                 | 25.532               | -8.030          | 43.500         | 9.938       | 100          | 108             | QP   |
| 3  |      | *    | 203.145         | 38.994                 | 26.662               | -4.506          | 43.500         | 12.333      | 100          | 161             | QP   |
| 4  |      |      | 284.140         | 36.381                 | 22.117               | -9.619          | 46.000         | 14.264      | 100          | 47              | QP   |
| 5  |      |      | 365.620         | 33.213                 | 17.117               | -12.787         | 46.000         | 16.096      | 100          | 202             | QP   |
| 6  |      |      | 480.080         | 32.268                 | 14.271               | -13.732         | 46.000         | 17.997      | 100          | 331             | QP   |

Note: Measure Level (dB $\mu$ V/m) = Reading Level (dB $\mu$ V) + Factor (dB)

Factor (dB) = Cable Loss (dB) + Antenna Factor (dB/m).



|                                      |                          |
|--------------------------------------|--------------------------|
| Site: AC2                            | Time: 2016/07/12 - 16:50 |
| Limit: FCC_Part15.109_RE(3m)_Class B | Engineer: Line Chen      |
| Probe: VULB9162_0.03-8GHz            | Polarity: Vertical       |
| EUT: E-reader                        | Power: AC 120V/60Hz      |
| Test Mode 2                          |                          |

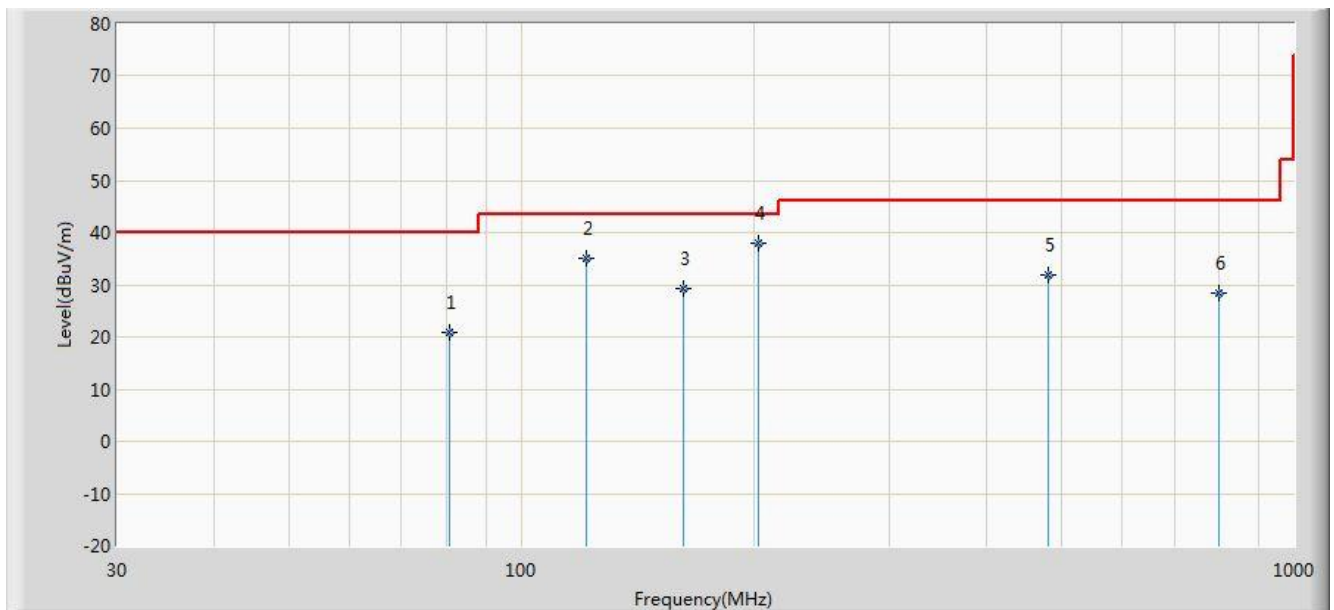

| No | Flag | Mark | Frequency (MHz) | Measure Level (dBuV/m) | Reading Level (dBuV) | Over Limit (dB) | Limit (dBuV/m) | Factor (dB) | Ant Pos (cm) | Table Pos (deg) | Type |
|----|------|------|-----------------|------------------------|----------------------|-----------------|----------------|-------------|--------------|-----------------|------|
| 1  |      |      | 80.925          | 20.917                 | 11.398               | -19.083         | 40.000         | 9.519       | 100          | 192             | QP   |
| 2  |      |      | 121.665         | 34.942                 | 23.903               | -8.558          | 43.500         | 11.039      | 100          | 85              | QP   |
| 3  |      |      | 162.405         | 29.266                 | 19.328               | -14.234         | 43.500         | 9.938       | 100          | 110             | QP   |
| 4  |      | *    | 203.145         | 38.114                 | 25.782               | -5.386          | 43.500         | 12.333      | 100          | 156             | QP   |
| 5  |      |      | 480.080         | 31.779                 | 13.782               | -14.221         | 46.000         | 17.997      | 100          | 329             | QP   |
| 6  |      |      | 798.725         | 28.382                 | 5.536                | -17.618         | 46.000         | 22.846      | 100          | 221             | QP   |

Note: Measure Level (dBuV/m) = Reading Level (dBuV) + Factor (dB)

Factor (dB) = Cable Loss (dB) + Antenna Factor (dB/m).

|                                      |                          |
|--------------------------------------|--------------------------|
| Site: AC2                            | Time: 2016/07/12 - 15:55 |
| Limit: FCC_Part15.109_RE(3m)_Class B | Engineer: Line Chen      |
| Probe: BBHA9120D_1-18GHz             | Polarity: Horizontal     |
| EUT: E-reader                        | Power: AC 120V/60Hz      |
| Test Mode 1                          |                          |

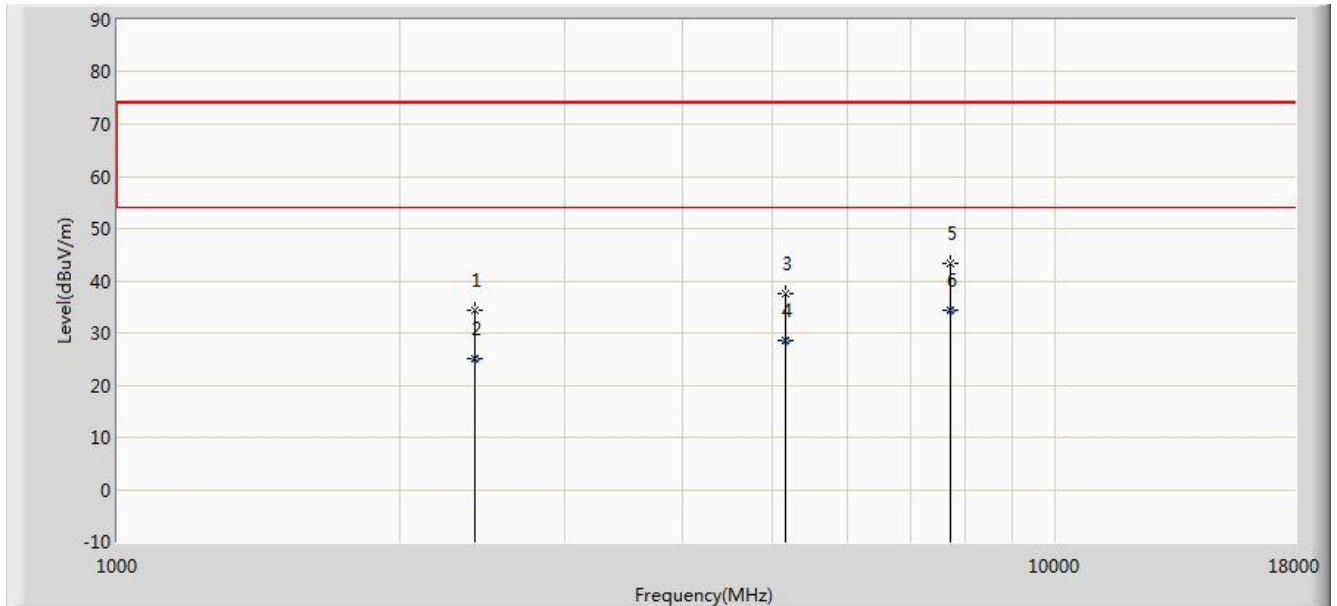

| No | Flag | Mark | Frequency (MHz) | Measure Level (dBuV/m) | Reading Level (dBuV) | Over Limit (dB) | Limit (dBuV/m) | Factor (dB) | Ant Pos (cm) | Table Pos (deg) | Type |
|----|------|------|-----------------|------------------------|----------------------|-----------------|----------------|-------------|--------------|-----------------|------|
| 1  |      |      | 2402.500        | 34.305                 | 36.990               | -39.695         | 74.000         | -2.685      | 100          | 136             | PK   |
| 2  |      |      | 2403.000        | 25.087                 | 27.773               | -28.913         | 54.000         | -2.687      | 100          | 139             | AV   |
| 3  |      |      | 5165.000        | 37.406                 | 34.418               | -36.594         | 74.000         | 2.988       | 100          | 203             | PK   |
| 4  |      |      | 5165.500        | 28.542                 | 25.552               | -25.458         | 54.000         | 2.990       | 100          | 217             | AV   |
| 5  |      |      | 7732.000        | 43.324                 | 32.848               | -30.676         | 74.000         | 10.477      | 100          | 339             | PK   |
| 6  |      | *    | 7732.500        | 34.483                 | 24.008               | -19.517         | 54.000         | 10.475      | 100          | 347             | AV   |

Note: Measure Level (dB $\mu$ V/m) = Reading Level (dB $\mu$ V) + Factor (dB)

Factor (dB) = Cable Loss (dB) + Antenna Factor (dB/m) – Pre\_Amplifier Gain (dB).

|                                      |                          |
|--------------------------------------|--------------------------|
| Site: AC2                            | Time: 2016/07/12 - 15:56 |
| Limit: FCC_Part15.109_RE(3m)_Class B | Engineer: Line Chen      |
| Probe: BBHA9120D_1-18GHz             | Polarity: Vertical       |
| EUT: E-reader                        | Power: AC 120V/60Hz      |
| Test Mode 1                          |                          |

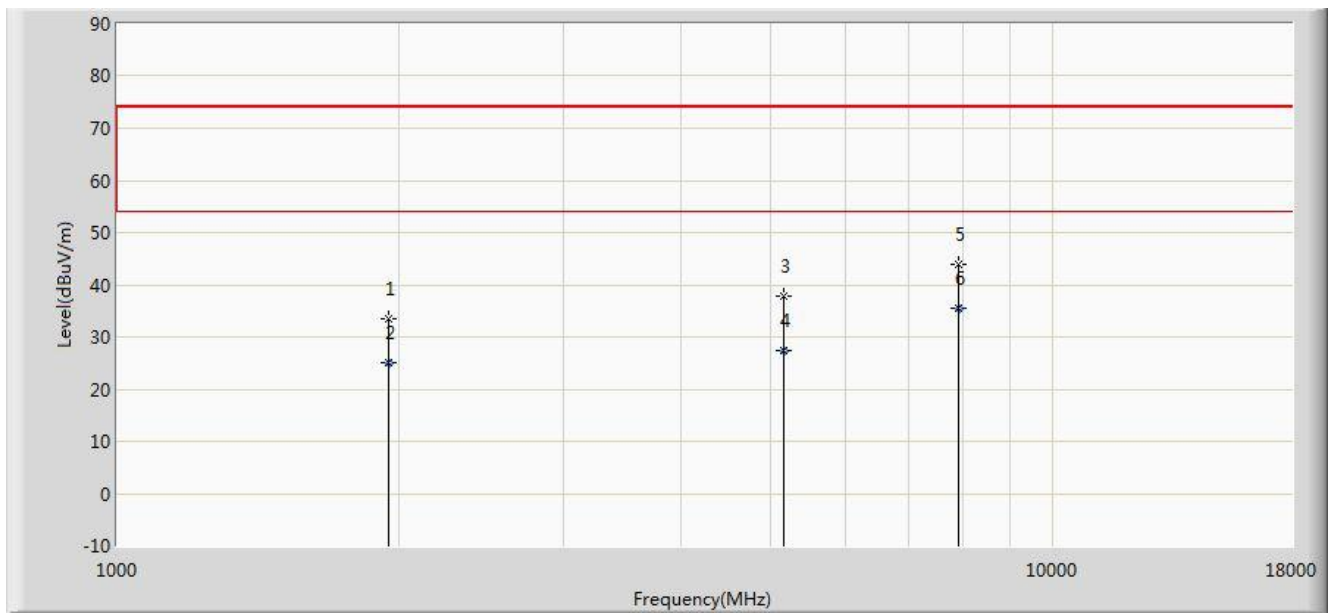

| No | Flag | Mark | Frequency (MHz) | Measure Level (dBuV/m) | Reading Level (dBuV) | Over Limit (dB) | Limit (dBuV/m) | Factor (dB) | Ant Pos (cm) | Table Pos (deg) | Type |
|----|------|------|-----------------|------------------------|----------------------|-----------------|----------------|-------------|--------------|-----------------|------|
| 1  |      |      | 1952.000        | 33.467                 | 38.349               | -40.533         | 74.000         | -4.881      | 100          | 72              | PK   |
| 2  |      |      | 1952.500        | 25.129                 | 30.003               | -28.871         | 54.000         | -4.874      | 100          | 93              | AV   |
| 3  |      |      | 5156.500        | 37.710                 | 34.664               | -36.290         | 74.000         | 3.046       | 100          | 302             | PK   |
| 4  |      |      | 5157.000        | 27.271                 | 24.228               | -26.729         | 54.000         | 3.043       | 100          | 307             | AV   |
| 5  |      |      | 7919.000        | 43.810                 | 33.193               | -30.190         | 74.000         | 10.617      | 100          | 221             | PK   |
| 6  |      | *    | 7919.500        | 35.498                 | 24.882               | -18.502         | 54.000         | 10.617      | 100          | 234             | AV   |

Note: Measure Level (dBuV/m) = Reading Level (dBuV) + Factor (dB)

Factor (dB) = Cable Loss (dB) + Antenna Factor (dB/m) – Pre\_Amplifier Gain (dB).

|                                      |                          |
|--------------------------------------|--------------------------|
| Site: AC2                            | Time: 2016/07/12 - 15:59 |
| Limit: FCC_Part15.109_RE(3m)_Class B | Engineer: Line Chen      |
| Probe: BBHA9120D_1-18GHz             | Polarity: Horizontal     |
| EUT: E-reader                        | Power: AC 120V/60Hz      |
| Test Mode 2                          |                          |

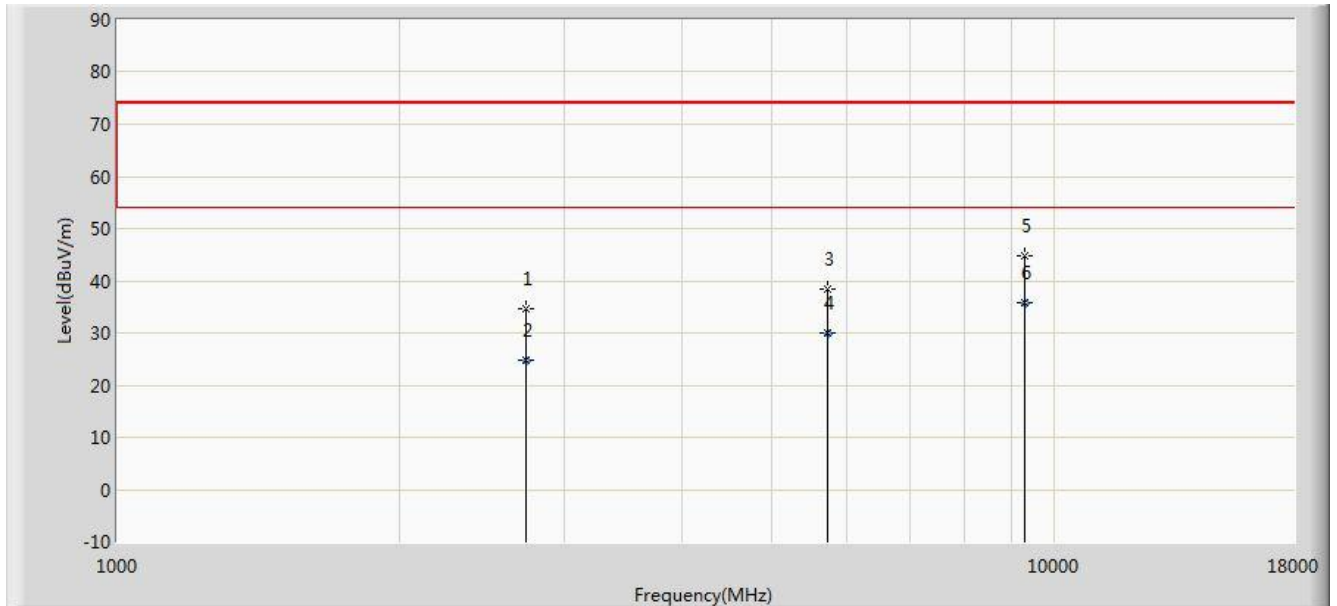

| No | Flag | Mark | Frequency (MHz) | Measure Level (dBuV/m) | Reading Level (dBuV) | Over Limit (dB) | Limit (dBuV/m) | Factor (dB) | Ant Pos (cm) | Table Pos (deg) | Type |
|----|------|------|-----------------|------------------------|----------------------|-----------------|----------------|-------------|--------------|-----------------|------|
| 1  |      |      | 2734.000        | 34.613                 | 36.920               | -39.387         | 74.000         | -2.307      | 100          | 189             | PK   |
| 2  |      |      | 2734.500        | 24.808                 | 27.118               | -29.192         | 54.000         | -2.310      | 100          | 175             | AV   |
| 3  |      |      | 5726.000        | 38.318                 | 34.188               | -35.682         | 74.000         | 4.131       | 100          | 271             | PK   |
| 4  |      |      | 5726.500        | 29.858                 | 25.715               | -24.142         | 54.000         | 4.143       | 100          | 254             | AV   |
| 5  |      |      | 9296.000        | 44.822                 | 32.053               | -29.178         | 74.000         | 12.769      | 100          | 82              | PK   |
| 6  |      | *    | 9296.500        | 35.882                 | 23.117               | -18.118         | 54.000         | 12.765      | 100          | 90              | AV   |

Note: Measure Level (dB $\mu$ V/m) = Reading Level (dB $\mu$ V) + Factor (dB)

Factor (dB) = Cable Loss (dB) + Antenna Factor (dB/m) – Pre\_Amplifier Gain (dB).

|                                      |                          |
|--------------------------------------|--------------------------|
| Site: AC2                            | Time: 2016/07/12 - 16:01 |
| Limit: FCC_Part15.109_RE(3m)_Class B | Engineer: Line Chen      |
| Probe: BBHA9120D_1-18GHz             | Polarity: Vertical       |
| EUT: E-reader                        | Power: AC 120V/60Hz      |
| Test Mode 2                          |                          |

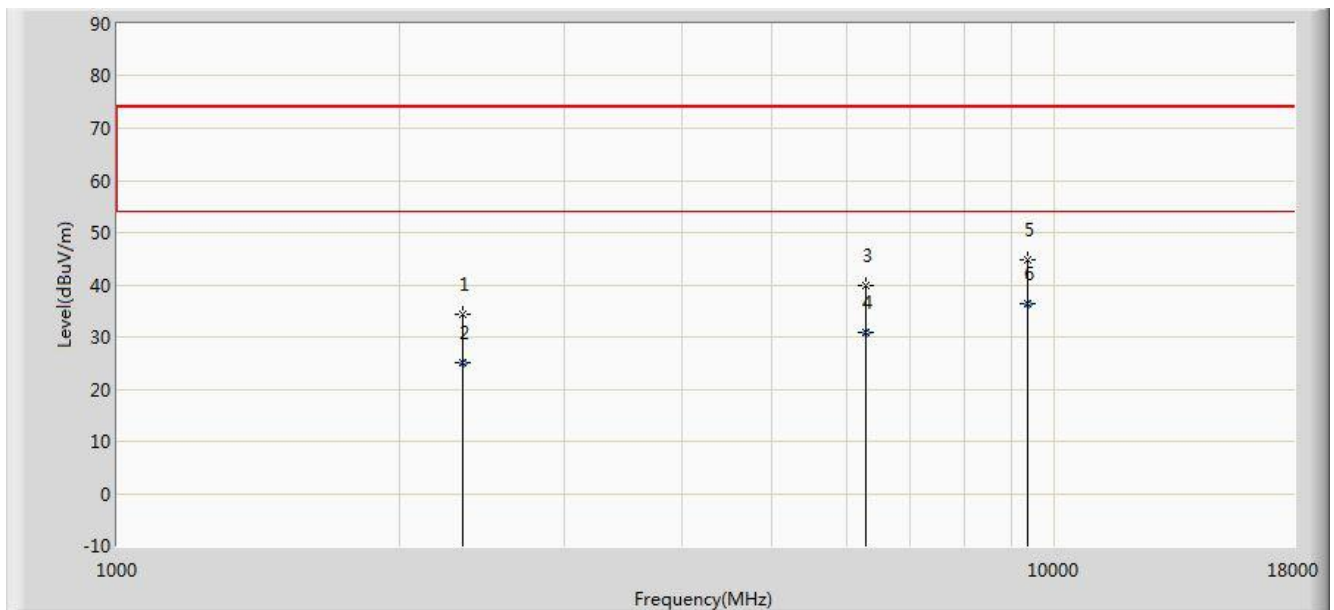

| No | Flag | Mark | Frequency (MHz) | Measure Level (dBuV/m) | Reading Level (dBuV) | Over Limit (dB) | Limit (dBuV/m) | Factor (dB) | Ant Pos (cm) | Table Pos (deg) | Type |
|----|------|------|-----------------|------------------------|----------------------|-----------------|----------------|-------------|--------------|-----------------|------|
| 1  |      |      | 2334.500        | 34.264                 | 36.584               | -39.736         | 74.000         | -2.319      | 100          | 118             | PK   |
| 2  |      |      | 2335.000        | 25.033                 | 27.361               | -28.967         | 54.000         | -2.328      | 100          | 123             | AV   |
| 3  |      |      | 6287.000        | 39.735                 | 33.750               | -34.265         | 74.000         | 5.985       | 100          | 232             | PK   |
| 4  |      |      | 6287.500        | 30.860                 | 24.882               | -23.140         | 54.000         | 5.978       | 100          | 241             | AV   |
| 5  |      |      | 9347.000        | 44.839                 | 32.422               | -29.161         | 74.000         | 12.418      | 100          | 78              | PK   |
| 6  |      | *    | 9347.500        | 36.358                 | 23.927               | -17.642         | 54.000         | 12.432      | 100          | 85              | AV   |

Note: Measure Level (dBuV/m) = Reading Level (dBuV) + Factor (dB)

Factor (dB) = Cable Loss (dB) + Antenna Factor (dB/m) – Pre\_Amplifier Gain (dB).

————— The End —————