



MEASUREMENT REPORT

FCC PART 15.247 WLAN 802.11b/g/n

FCC ID: XR3-C67

APPLICANT: ONYX INTERNATIONAL INC.

Application Type: Certification

Product: E-reader

Model No.: C67, C67ML, C67HD, C67S, C67SML, C67 Touch, C67ML Carta, C67ML Carta2, ONYX BOOX C67ML MAGELLAN 2, ONYX BOOX C67M ERMAK 2, ONYX BOOX C67SML COLUMBUS, Tagus Lux, Tagus Tactil, ONYX BOOX DARWIN 3, ONYX BOOX DARWIN 4, ONYX BOOX CAESAR 2, ONYX BOOX VASCO DA GAMA 2

Trademark: BOOX

FCC Classification: Digital Transmission System (DTS)

FCC Rule Part(s): Part 15.247

Test Procedure(s): ANSI C63.10-2013, KDB 558074 D01v03r05, KDB 662911 D01v02r01

Test Date: March 03 ~ 18, 2017

Reviewed By : Robin Wu
(Robin Wu)

Approved By : Marlin Chen
(Marlin Chen)



The test results relate only to the samples tested.

This equipment has been shown to be capable of compliance with the applicable technical standards as indicated in the measurement report and was tested in accordance with the measurement procedures specified in KDB 558074 D01v03r05. Test results reported herein relate only to the item(s) tested.

The test report shall not be reproduced except in full without the written approval of MRT Technology (Suzhou) Co., Ltd.

Revision History

Report No.	Version	Description	Issue Date	Note
1703RSU00501	Rev. 01	Initial report	03-24-2017	Valid

CONTENTS

Description	Page
§2.1033 General Information.....	5
1. INTRODUCTION.....	6
1.1. Scope.....	6
1.2. MRT Test Location.....	6
2. PRODUCT INFORMATION.....	7
2.1. Equipment Description.....	7
2.2. Working Frequencies.....	7
2.3. Test Mode.....	8
2.4. Test Software.....	9
2.5. Device Capabilities.....	10
2.6. Test Configuration.....	11
2.7. EMI Suppression Device(s)/Modifications.....	11
2.8. Labeling Requirements.....	11
3. DESCRIPTION of TEST.....	12
3.1. Evaluation Procedure.....	12
3.2. AC Line Conducted Emissions.....	12
3.3. Radiated Emissions.....	13
4. ANTENNA REQUIREMENTS.....	14
5. TEST EQUIPMENT CALIBRATION DATE.....	15
6. MEASUREMENT UNCERTAINTY.....	16
7. TEST RESULT.....	17
7.1. Summary.....	17
7.2. 6dB Bandwidth Measurement.....	18
7.2.1. Test Limit.....	18
7.2.2. Test Procedure used.....	18
7.2.3. Test Setting.....	18
7.2.4. Test Setup.....	18
7.2.5. Test Result.....	19
7.3. Output Power Measurement.....	24
7.3.1. Test Limit.....	24
7.3.2. Test Procedure Used.....	24
7.3.3. Test Setting.....	24
7.3.4. Test Setup.....	24

7.3.5.	Test Result of Output Power	25
7.4.	Power Spectral Density Measurement.....	28
7.4.1.	Test Limit	28
7.4.2.	Test Procedure Used	28
7.4.3.	Test Setting.....	28
7.4.4.	Test Setup	28
7.4.5.	Test Result.....	29
7.5.	Conducted Band Edge and Out-of-Band Emissions	34
7.5.1.	Test Limit	34
7.5.2.	Test Procedure Used	34
7.5.3.	Test Setting.....	34
7.5.4.	Test Setup	35
7.5.5.	Test Result.....	36
7.6.	Radiated Spurious Emission Measurement	45
7.6.1.	Test Limit	45
7.6.2.	Test Procedure Used	45
7.6.3.	Test Setting.....	45
7.6.4.	Test Setup	47
7.6.5.	Test Result.....	49
7.7.	Radiated Restricted Band Edge Measurement.....	63
7.7.1.	Test Result.....	63
7.8.	AC Conducted Emissions Measurement	95
7.8.1.	Test Limit	95
7.8.2.	Test Setup	95
7.8.3.	Test Result.....	96
8.	CONCLUSION	98

§2.1033 General Information

Applicant:	ONYX INTERNATIONAL INC.
Applicant Address:	Room 102, 3rd Floor, No. 38 HongLou Road, LiWan District, GuangZhou, China
Manufacturer:	ONYX INTERNATIONAL INC.
Manufacturer Address:	Room 102, 3rd Floor, No. 38 HongLou Road, LiWan District, GuangZhou, China
Test Site:	MRT Technology (Suzhou) Co., Ltd
Test Site Address:	D8 Building, No.2 Tian'edang Rd., Wuzhong Economic Development Zone, Suzhou, China
MRT Registration No.:	809388
FCC Rule Part(s):	Part 15.247
Model No.:	C67, C67ML, C67HD, C67S, C67SML, C67 Touch, C67ML Carta, C67ML Carta2, ONYX BOOX C67ML MAGELLAN 2, ONYX BOOX C67M ERMAK 2, ONYX BOOX C67SML COLUMBUS, Tagus Lux, Tagus Tactil, ONYX BOOX DARWIN 3, ONYX BOOX DARWIN 4, ONYX BOOX CAESAR 2, ONYX BOOX VASCO DA GAMA 2
FCC ID:	XR3-C67
Test Device Serial No.:	N/A <input type="checkbox"/> Production <input checked="" type="checkbox"/> Pre-Production <input type="checkbox"/> Engineering

Test Facility / Accreditations

Measurements were performed at MRT Laboratory located in Tian'edang Rd., Suzhou, China.

- MRT facility is a FCC registered (MRT Reg. No. 809388) test facility with the site description report on file and has met all the requirements specified in Section 2.948 of the FCC Rules.
- MRT facility is an IC registered (MRT Reg. No. 11384A-1) test laboratory with the site description on file at Industry Canada.
- MRT facility is a VCCI registered (R-4179, G-814, C-4664, T-2206) test laboratory with the site description on file at VCCI Council.
- MRT Lab is accredited to ISO 17025 by the American Association for Laboratory Accreditation (A2LA) under the American Association for Laboratory Accreditation Program (A2LA Cert. No. 3628.01) in EMC, Telecommunications and Radio testing for FCC, Industry Canada, EU and TELEC Rules.



1. INTRODUCTION

1.1. Scope

Measurement and determination of electromagnetic emissions (EMC) of radio frequency devices including intentional and/or unintentional radiators for compliance with the technical rules and regulations of the Federal Communications Commission and the Industry Canada Certification and Engineering Bureau.

1.2. MRT Test Location

The map below shows the location of the MRT LABORATORY, its proximity to the Taihu Lake. These measurement tests were conducted at the MRT Technology (Suzhou) Co., Ltd. Facility located at D8 Building, No.2 Tian'edang Rd., Wuzhong Economic Development Zone, Suzhou, China. The detailed description of the measurement facility was found to be in compliance with the requirements of § 2.948 according to ANSI C63.4-2009 on September 30, 2013.



2. PRODUCT INFORMATION

2.1. Equipment Description

Product Name	E-reader
Model No.	C67, C67ML, C67HD, C67S, C67SML, C67 Touch, C67ML Carta, C67ML Carta2, ONYX BOOX C67ML MAGELLAN 2, ONYX BOOX C67M ERMAK 2, ONYX BOOX C67SML COLUMBUS, Tagus Lux, Tagus Tactil, ONYX BOOX DARWIN 3, ONYX BOOX DARWIN 4, ONYX BOOX CAESAR 2, ONYX BOOX VASCO DA GAMA 2
Brand Name:	BOOX
Frequency Range	802.11b/g/n-HT20: 2412 ~ 2462 MHz 802.11n-HT40: 2422 ~ 2452 MHz
Maximum Output Power	802.11b: 11.48dBm 802.11g: 17.83dBm 802.11n-HT20: 17.75dBm 802.11n-HT40: 17.88dBm
Type of Modulation	802.11b: DSSS 802.11g/n: OFDM
Antenna Gain	1.0dBi

Note: Differences between all models are for different marketing requirement.

2.2. Working Frequencies

Channel List for 802.11b/g/n-HT20

Channel	Frequency	Channel	Frequency	Channel	Frequency
01	2412 MHz	02	2417 MHz	03	2422 MHz
04	2427 MHz	05	2432 MHz	06	2437 MHz
07	2442 MHz	08	2447 MHz	09	2452 MHz
10	2457 MHz	11	2462 MHz	--	--

Channel List for 802.11n-HT40

Channel	Frequency	Channel	Frequency	Channel	Frequency
03	2422 MHz	04	2427 MHz	05	2432 MHz
06	2437 MHz	07	2442 MHz	08	2447 MHz
09	2452 MHz	--	--	--	--

2.3. Test Mode

Test Mode	Mode 1: Transmit by 802.11b
	Mode 2: Transmit by 802.11g
	Mode 3: Transmit by 802.11n-HT20
	Mode 4: Transmit by 802.11n-HT40

2.4. Test Software

The test utility software used during testing was “REALTEK 11n 8188EUS USB WLAN NIC Massproduction Kit”.

2.5. Device Capabilities

This device contains the following capabilities:

2.4GHz WLAN (DTS).

Note: 2.4GHz WLAN (DTS) operation is possible in 20MHz, and 40MHz channel bandwidths. The maximum achievable duty cycles for all modes were determined based on measurements performed on a spectrum analyzer in zero-span mode with RBW = 8MHz, VBW = 50MHz, and detector = peak per the guidance of Section 6.0 b) of KDB 558074 D01v03r05. The RBW and VBW were both greater than 50/T, where T is the minimum transmission duration, and the number of sweep points across T was greater than 100. The duty cycles are as follows:

Test Mode	Duty Cycle
802.11b	100.00%
802.11g	100.00%
802.11n-HT20	100.00%
802.11n-HT40	100.00%

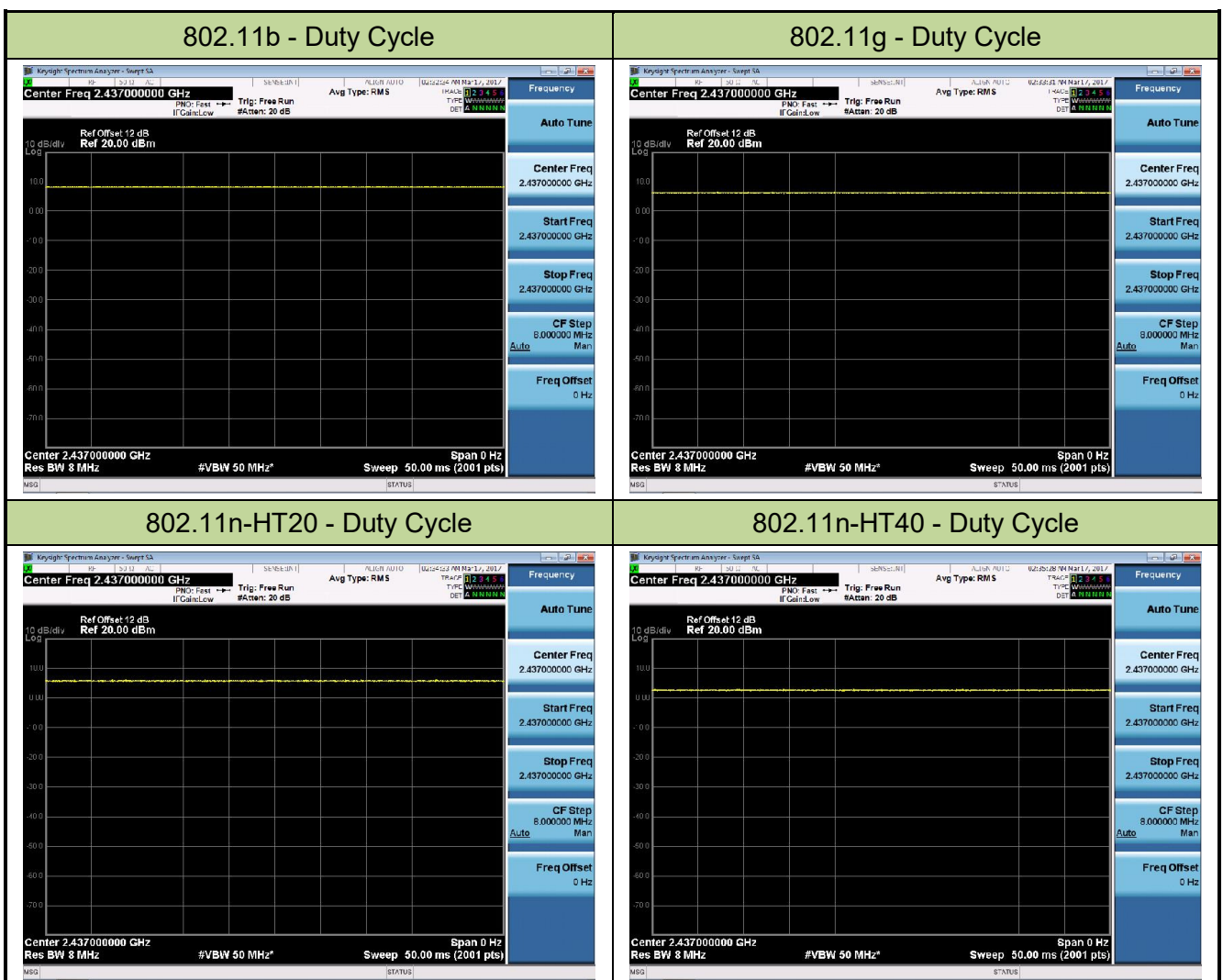

2.6. Test Configuration

The **E-reader FCC ID: XR3-C67** was tested per the guidance of KDB 558074 D01v03r05. ANSI C63.10-2013 was used to reference the appropriate EUT setup for radiated spurious emissions testing and AC line conducted testing.

2.7. EMI Suppression Device(s)/Modifications

No EMI suppression device(s) were added and/or no modifications were made during testing.

2.8. Labeling Requirements

Per 2.1074 & 15.19; Docket 95-19

The label shall be permanently affixed at a conspicuous location on the device; instruction manual or pamphlet supplied to the user and be readily visible to the purchaser at the time of purchase. However, when the device is so small wherein placement of the label with specified statement is not practical, only the FCC ID must be displayed on the device per Section 15.19(a)(5). Please see attachment for FCC ID label and label location.

3. DESCRIPTION of TEST

3.1. Evaluation Procedure

The measurement procedures described in the American National Standard for Testing Unlicensed Wireless Devices (ANSI C63.10-2013), and the guidance provided in KDB 558074 D01v03r05 were used in the measurement of the **E-reader FCC ID: XR3-C67**.

Deviation from measurement procedure.....None

3.2. AC Line Conducted Emissions

The line-conducted facility is located inside an 8'x4'x4' shielded enclosure. A 1m x 2m wooden table 80cm high is placed 40cm away from the vertical wall and 80cm away from the sidewall of the shielded room. Two 10kHz-30MHz, 50Ω/50uH Line-Impedance Stabilization Networks (LISNs) are bonded to the shielded room floor. Power to the LISNs is filtered by external high-current high-insertion loss power line filters. These filters attenuate ambient signal noise from entering the measurement lines. These filters are also bonded to the shielded enclosure.

The EUT is powered from one LISN and the support equipment is powered from the second LISN. All interconnecting cables more than 1 meter were shortened to a 1 meter length by non-inductive bundling (serpentine fashion) and draped over the back edge of the test table. All cables were at least 40cm above the horizontal reference ground-plane. Power cables for support equipment were routed down to the second LISN while ensuring that that cables were not draped over the second LISN.

Sufficient time for the EUT, support equipment, and test equipment was allowed in order for them to warm up to their normal operating condition. The RF output of the LISN was connected to the receiver and exploratory measurements were made to determine the frequencies producing the maximum emission from the EUT. The receiver was scanned from 150kHz to 30MHz. The detector function was set to peak mode for exploratory measurements while the bandwidth of the analyzer was set to 9kHz. The EUT, support equipment, and interconnecting cables were arranged and manipulated to maximize each emission. Each emission was also maximized by varying: power lines, the mode of operation or data exchange speed, or support equipment whichever determined the worst-case emission. Once the worst case emissions have been identified, the one EUT cable configuration/arrangement and mode of operation that produced these emissions are used for final measurements on the same test site. The analyzer is set to CISPR quasi-peak and average detectors with a 9kHz resolution bandwidth for final measurements.

An extension cord was used to connect to a single LISN which powered by EUT. The extension cord was calibrated with LISN, the impedance and insertion loss are compliance with the requirements as stated in ANSI C63.10-2013.

Line conducted emissions test results are shown in Section 7.8.

3.3. Radiated Emissions

The radiated test facilities consisted of an indoor 3 meter semi-anechoic chamber used for final measurements and exploratory measurements, when necessary. The measurement area is contained within the semi-anechoic chamber which is shielded from any ambient interference. For measurements above 1GHz absorbers are arranged on the floor between the turn table and the antenna mast in such a way so as to maximize the reduction of reflections. For measurements below 1GHz, the absorbers are removed. A MF Model 210SS turntable is used for radiated measurement. It is a continuously rotatable, remote controlled, metallic turntable and 2 meters (6.56 ft.) in diameter. The turn table is flush with the raised floor of the chamber in order to maintain its function as a ground plane. An 80cm high PVC support structure is placed on top of the turntable.

For all measurements, the spectrum was scanned through all EUT azimuths and from 1 to 4 meter receive antenna height using a broadband antenna from 30MHz up to the upper frequency shown in 15.33(b)(1) depending on the highest frequency generated or used in the device or on which the device operates or tunes. For frequencies above 1GHz, linearly polarized double ridge horn antennas were used. For frequencies below 30MHz, a calibrated loop antenna was used. When exploratory measurements were necessary, they were performed at 1 meter test distance inside the semi-anechoic chamber using broadband antennas, broadband amplifiers, and spectrum analyzers to determine the frequencies and modes producing the maximum emissions. Sufficient time for the EUT, support equipment, and test equipment was allowed in order for them to warm up to their normal operating condition. The test set-up for frequencies below 1GHz was placed on top of the 0.8 meter high, 1 x 1.5 meter table; and test set-up for frequencies 1-40GHz was placed on top of the 1.5 meter high, 1 x 1.5 meter table. The EUT, support equipment, and interconnecting cables were arranged and manipulated to maximize each emission. Appropriate precaution was taken to ensure that all emissions from the EUT were maximized and investigated. The system configuration, clock speed, mode of operation or video resolution, if applicable, turntable azimuth, and receive antenna height was noted for each frequency found.

Final measurements were made in the semi-anechoic chamber using calibrated, linearly polarized broadband and horn antennas. The test setup was configured to the setup that produced the worst case emissions. The spectrum analyzer was set to investigate all frequencies required for testing to compare the highest radiated disturbances with respect to the specified limits. The turntable containing the EUT was rotated through 360 degrees and the height of the receive antenna was varied 1 to 4 meters and stopped at the azimuth and height producing the maximum emission. Each emission was maximized by changing the orientation of the EUT through three orthogonal planes and changing the polarity of the receive antenna, whichever produced the worst-case emissions. According to 3dB Beam-Width of horn antenna, the horn antenna should be always directed to the EUT when rising height.

4. ANTENNA REQUIREMENTS

Excerpt from §15.203 of the FCC Rules/Regulations:

“An intentional radiator antenna shall be designed to ensure that no antenna other than that furnished by the responsible party can be used with the device. The use of a permanently attached antenna or of an antenna that uses a unique coupling to the intentional radiator shall be considered sufficient to comply with the provisions of this section.”

- The antenna of the Radio Controller is **permanently attached**.
- There are no provisions for connection to an external antenna.

Conclusion:

The **E-reader FCC ID: XR3-C67** unit complies with the requirement of §15.203.

5. TEST EQUIPMENT CALIBRATION DATE

Conducted Emissions - SR2

Instrument	Manufacturer	Type No.	Serial No.	Cali. Interval	Cali. Due Date
EMI Test Receiver	R&S	ESR7	102030	1 year	2017/05/08
Two-Line V-Network	R&S	ENV216	101683	1 year	2017/06/21
Two-Line V-Network	R&S	ENV216	101684	1 year	2017/06/21
Temperature/Humidity Meter	Yuhuaze	HTC-2	N/A	1 year	2017/12/22
Shielding Anechoic Chamber	Mikebang	Chamber-SR2	N/A	1 year	2017/05/10

Radiated Disturbance - AC2

Instrument	Manufacturer	Type No.	Serial No.	Cali. Interval	Cali. Due Date
MXE EMI Receiver	Agilent	N9038A	MY51210182	1 year	2017/08/03
Loop Antenna	Schwarzbeck	FMZB1519	100982	1 year	2017/12/21
TRILOG Antenna	Schwarzbeck	VULB9162	9162-047	1 year	2017/10/22
Broad-Band Horn Antenna	Schwarzbeck	BBHA9120D	1457	1 year	2017/11/19
Broadband Coaxial Preamp	Schwarzbeck	BBV 9718	MY52090106	1 year	2017/12/10
Broadband Horn Antenna	Schwarzbeck	BBHA9170	BBHA917054	1 year	2017/04/16
Digital Thermometer & Hygrometer	Minggao	ETH529	N/A	1 year	2017/11/30
Anechoic Chamber	RIKEN	Chamber-AC2	N/A	1 year	2017/05/10

Conducted Test Equipment - TR3

Instrument	Manufacturer	Type No.	Serial No.	Cali. Interval	Cali. Due Date
Spectrum Analyzer	Agilent	N9020A	MY52090106	1 year	2017/05/08
USB Wideband Power Sensor	Boonton	55006	8911	1 year	2017/05/08
Temperature/Humidity Meter	Yuhuaze	HTC-2	N/A	1 year	2017/12/22

Software	Version	Function
e3	V8.3.5	EMI Test Software

6. MEASUREMENT UNCERTAINTY

Where relevant, the following test uncertainty levels have been estimated for tests performed on the EUT as specified in CISPR 16-4-2. This uncertainty represents an expanded uncertainty expressed at approximately the 95% confidence level using a coverage factor of $k = 2$.

AC Conducted Emission Measurement - SR2
Measuring Uncertainty for a Level of Confidence of 95% ($U=2Uc(y)$): 150kHz~30MHz: $\pm 3.46\text{dB}$
Radiated Emission Measurement - AC2
Measuring Uncertainty for a Level of Confidence of 95% ($U=2Uc(y)$): 9kHz ~ 1GHz: $\pm 4.18\text{dB}$ 1GHz ~ 25GHz: $\pm 4.76\text{dB}$

7. TEST RESULT

7.1. Summary

Product Name: E-reader
FCC ID: XR3-C67
FCC Classification: Digital Transmission System (DTS)
Data Rate(s) Tested: 1Mbps ~ 11Mbps (b);
6Mbps ~ 54Mbps (g);
6.5/7.2Mbps ~ 65.0/72.2Mbps (n-HT20);
13.5/15.0Mbps ~ 135.0/150.0Mbps (n-HT40)

FCC Part Section(s)	Test Description	Test Limit	Test Condition	Test Result	Reference
15.247(a)(2)	6dB Bandwidth	$\geq 500\text{kHz}$	Conducted	Pass	Section 7.2
15.247(b)(3)	Output Power	$\leq 30.00\text{dBm}$		Pass	Section 7.3
15.247(e)	Power Spectral Density	$\leq 8.00\text{dBm}/3\text{kHz}$		Pass	Section 7.4
15.247(d)	Band Edge / Out-of-Band Emissions	$\leq 20\text{dBc(Average)}$		Pass	Section 7.5
15.205 15.209	General Field Strength Limits (Restricted Bands and Radiated Emission Limits)	Emissions in restricted bands must meet the radiated limits detailed in 15.209	Radiated	Pass	Section 7.6 & 7.7
15.207	AC Conducted Emissions 150kHz - 30MHz	< FCC 15.207 limits	Line Conducted	Pass	Section 7.8

Notes:

- 1) All modes of operation and data rates were investigated. For radiated emission test, every axis (X, Y, Z) was also verified. The test results shown in the following sections represent the worst case emissions.
- 2) The analyzer plots shown in this section were all taken with a correction table loaded into the analyzer. The correction table was used to account for the losses of the cables and attenuators used as part of the system to connect the EUT to the analyzer at all frequencies of interest.
- 3) All antenna port conducted emissions testing was performed on a test bench with the antenna port of the EUT connected to the spectrum analyzer through calibrated cables and attenuators.

7.2. 6dB Bandwidth Measurement

7.2.1. Test Limit

The minimum 6dB bandwidth shall be at least 500 kHz.

7.2.2. Test Procedure used

KDB 558074 D01v03r05 - Section 8.2 Option 2

7.2.3. Test Setting

1. The Spectrum's automatic bandwidth measurement capability was used to perform the 6dB bandwidth measurement. The "X" dB bandwidth parameter was set to $X = 6$. The bandwidth measurement was not influenced by any intermediate power nulls in the fundamental emission.
2. Set RBW = 100 kHz
3. VBW $\geq 3 \times$ RBW
4. Detector = Peak
5. Trace mode = max hold
6. Sweep = auto couple
7. Allow the trace was allowed to stabilize

7.2.4. Test Setup

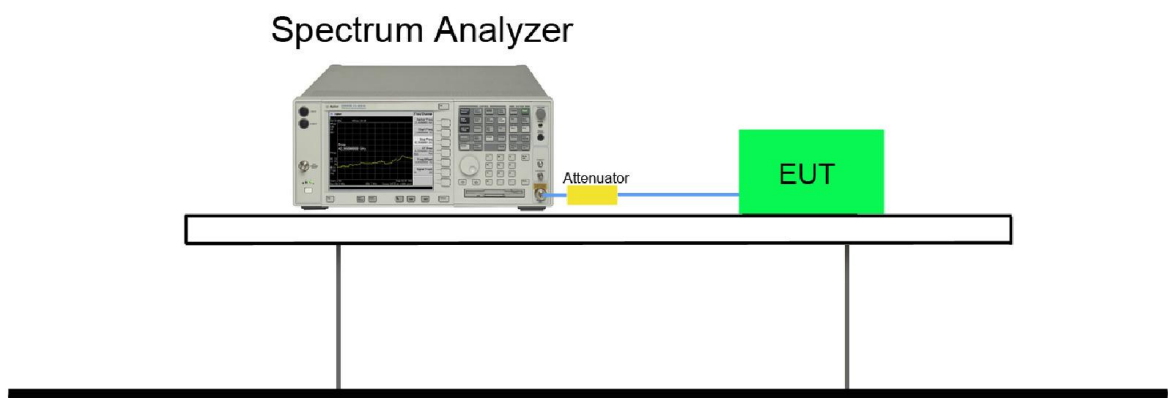

7.2.5. Test Result

Test Mode	Data Rate (Mbps)	Channel No.	Frequency (MHz)	6dB Bandwidth (MHz)	Limit (MHz)	Result
802.11b	1	01	2412	10.09	≥ 0.5	Pass
802.11b	1	06	2437	10.09	≥ 0.5	Pass
802.11b	1	11	2462	10.10	≥ 0.5	Pass
802.11g	6	01	2412	16.60	≥ 0.5	Pass
802.11g	6	06	2437	16.60	≥ 0.5	Pass
802.11g	6	11	2462	16.60	≥ 0.5	Pass
802.11n-HT20	13	01	2412	17.84	≥ 0.5	Pass
802.11n-HT20	13	06	2437	17.83	≥ 0.5	Pass
802.11n-HT20	13	11	2462	17.83	≥ 0.5	Pass
802.11n-HT40	27	03	2422	36.43	≥ 0.5	Pass
802.11n-HT40	27	06	2437	36.41	≥ 0.5	Pass
802.11n-HT40	27	09	2452	36.41	≥ 0.5	Pass

802.11b 6dB Bandwidth

Channel 01 (2412MHz)



Channel 06 (2437MHz)

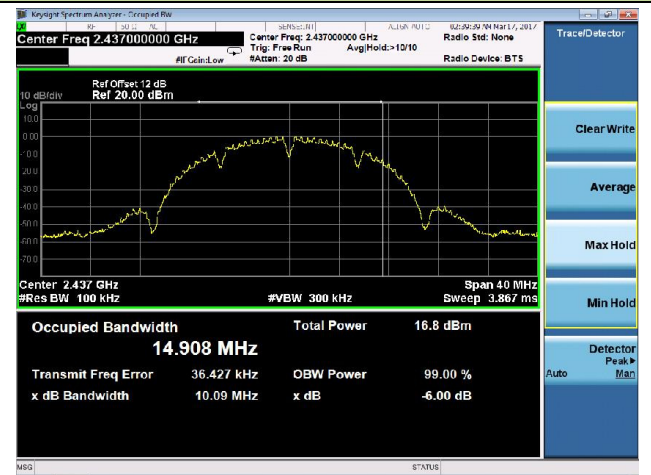

Channel 11 (2462MHz)



802.11g 6dB Bandwidth

Channel 01 (2412MHz)

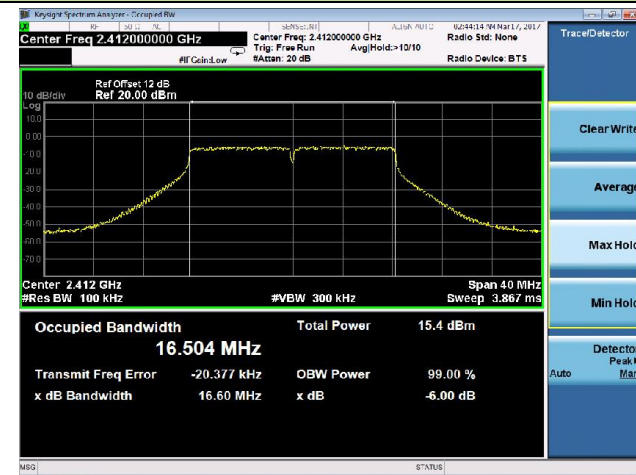

Channel 06 (2437MHz)

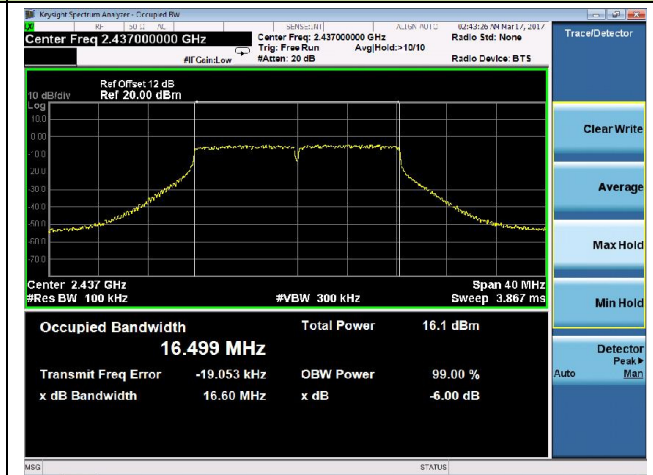

Channel 11 (2462MHz)

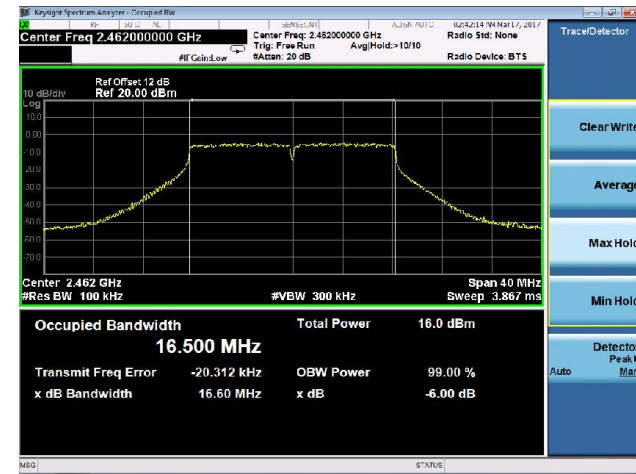

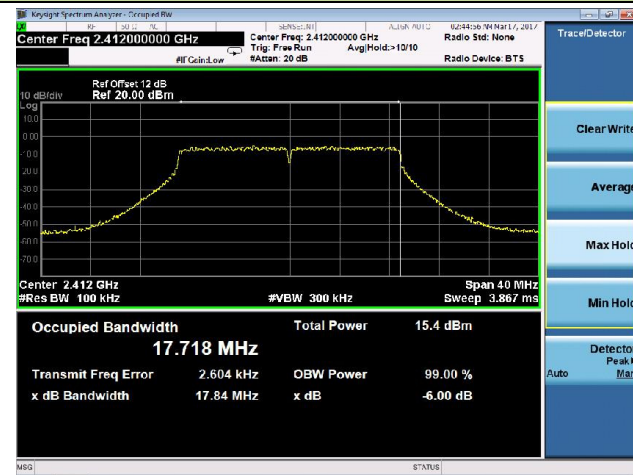
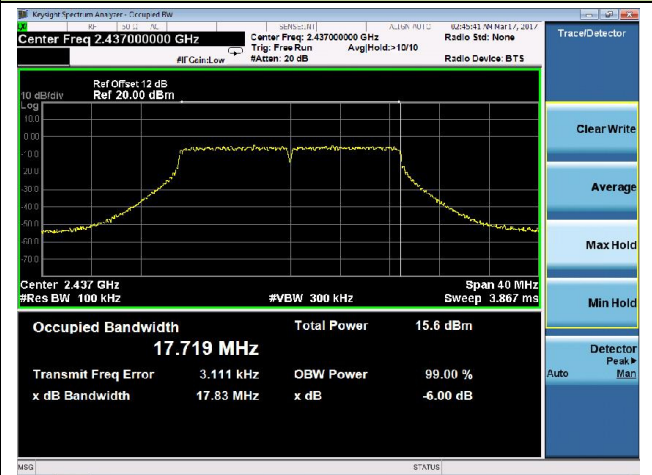
802.11n-HT20 6dB Bandwidth
Channel 01 (2412MHz)

Channel 06 (2437MHz)

Channel 11 (2462MHz)

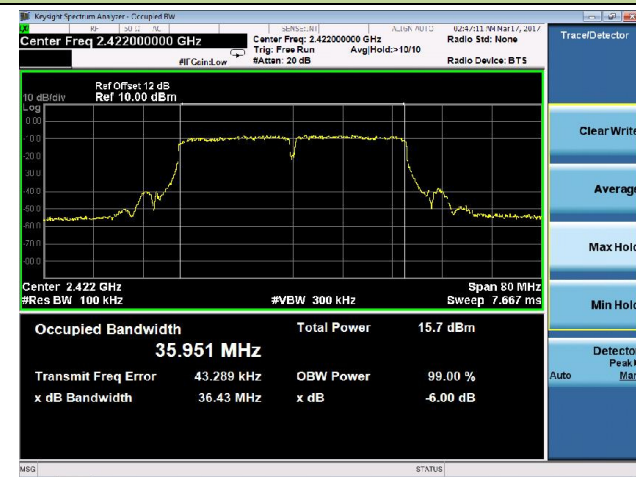
802.11n-HT40 6dB Bandwidth

Channel 03 (2422MHz)



Channel 06 (2437MHz)



Channel 09 (2452MHz)



7.3. Output Power Measurement

7.3.1. Test Limit

The maximum out power shall be less 1 Watt (30dBm).

7.3.2. Test Procedure Used

KDB 558074 D01v03r05 - Section 9.1.2 PKPM1 Peak Power Method (for signals with $BW \leq 50\text{MHz}$)

7.3.3. Test Setting

Method PKPM1 (Peak Power Measurement of Signals with DTS $BW \leq 50\text{MHz}$)

Peak power measurements were performed only when the EUT was transmitting at its maximum power control level using a broadband power meter with a pulse sensor. The pulse sensor employs a VBW = 50MHz so this method was only used for signals whose DTS bandwidth was less than or equal to 50MHz.

7.3.4. Test Setup

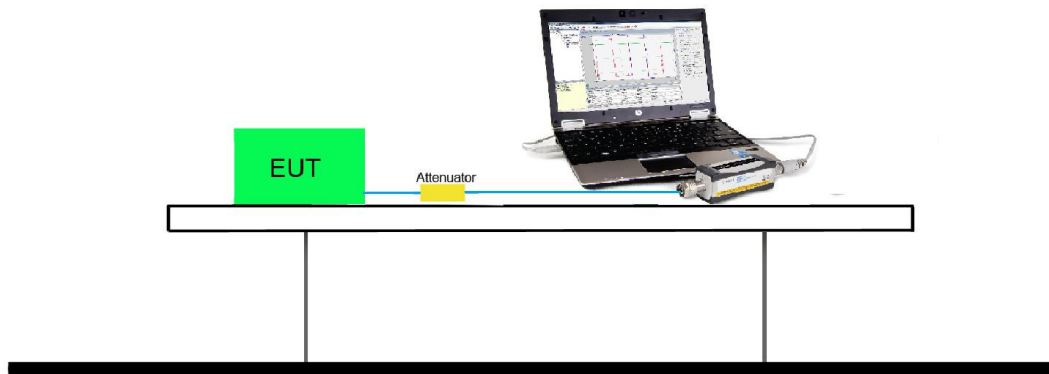

7.3.5. Test Result of Output Power

Power output test was verified over all data rates of each mode shown as below, and then choose the maximum power output (yellow marker) for final test of each channel.

MCS Index for 802.11n	N _{TX}	Data Rate (Mbps)					
		802.11b	802.11g	20MHz Bandwidth		40MHz Bandwidth	
				800ns GI	400ns GI	800ns GI	400ns GI
0	1	1	6	6.5	7.2	13.5	15.0
1	1	2	9	13.0	14.4	27.0	30.0
2	1	5.5	12	19.5	21.7	40.5	45.0
3	1	11	18	26.0	28.9	54.0	60.0
4	1	--	24	39.0	43.3	81.0	90.0
5	1	--	36	52.0	57.8	108.0	120.0
6	1	--	48	58.5	65.0	121.5	135.0
7	1	--	54	65.0	72.2	135.0	150.0

Output power at various data rates for Ant 0:

Test Mode	Bandwidth (MHz)	Channel No.	Frequency (MHz)	Data Rate (Mbps)	Peak Power (dBm)
802.11b	20	6	2437	1	11.41
				5.5	11.23
				11	11.07
802.11g	20	6	2437	6	17.66
				24	17.43
				54	17.12
802.11n	20	6	2437	6.5	17.75
				7.2	17.70
				39.0	17.53
				43.3	17.50
				65.0	17.30
				72.2	17.26
802.11n	40	6	2437	13.5	17.75
				15.0	17.73
				81.0	17.49
				90.0	17.43
				135.0	17.24
				150.0	17.21

Test Result of Peak Output Power

Test Mode	Data Rate (Mbps)	Channel No.	Frequency (MHz)	Peak Output Power (dBm)	Limit (dBm)	Result
802.11b	1	01	2412	11.48	≤ 30	Pass
802.11b	1	06	2437	11.41	≤ 30	Pass
802.11b	1	11	2462	11.21	≤ 30	Pass
802.11g	6	01	2412	17.63	≤ 30	Pass
802.11g	6	06	2437	17.66	≤ 30	Pass
802.11g	6	11	2462	17.83	≤ 30	Pass
802.11n-HT20	6.5	01	2412	17.17	≤ 30	Pass
802.11n-HT20	6.5	06	2437	17.75	≤ 30	Pass
802.11n-HT20	6.5	11	2462	17.27	≤ 30	Pass
802.11n-HT40	13.5	03	2422	17.37	≤ 30	Pass
802.11n-HT40	13.5	06	2437	17.75	≤ 30	Pass
802.11n-HT40	13.5	09	2452	17.88	≤ 30	Pass

Test Result of Average Output Power for Report Only

Test Mode	Data Rate (Mbps)	Channel No.	Frequency (MHz)	Average Output Power (dBm)	Limit (dBm)	Result
802.11b	1	01	2412	8.91	≤ 30	Pass
802.11b	1	06	2437	8.87	≤ 30	Pass
802.11b	1	11	2462	8.82	≤ 30	Pass
802.11g	6	01	2412	8.70	≤ 30	Pass
802.11g	6	06	2437	8.73	≤ 30	Pass
802.11g	6	11	2462	8.97	≤ 30	Pass
802.11n-HT20	6.5	01	2412	8.65	≤ 30	Pass
802.11n-HT20	6.5	06	2437	8.89	≤ 30	Pass
802.11n-HT20	6.5	11	2462	8.73	≤ 30	Pass
802.11n-HT40	13.5	03	2422	8.81	≤ 30	Pass
802.11n-HT40	13.5	06	2437	8.85	≤ 30	Pass
802.11n-HT40	13.5	09	2452	8.82	≤ 30	Pass

7.4. Power Spectral Density Measurement

7.4.1. Test Limit

The maximum permissible power spectral density is 8dBm in any 3 kHz band.

7.4.2. Test Procedure Used

KDB 558074 D01v03r05 - Section 10.2 Method PKPSD

7.4.3. Test Setting

1. Analyzer was set to the center frequency of the DTS channel under investigation
2. Span = 1.5 times the DTS channel bandwidth
3. RBW = 3kHz
4. VBW = 10kHz
5. Detector = peak
6. Sweep time = auto couple
7. Trace mode = max hold
8. Trace was allowed to stabilize

7.4.4. Test Setup

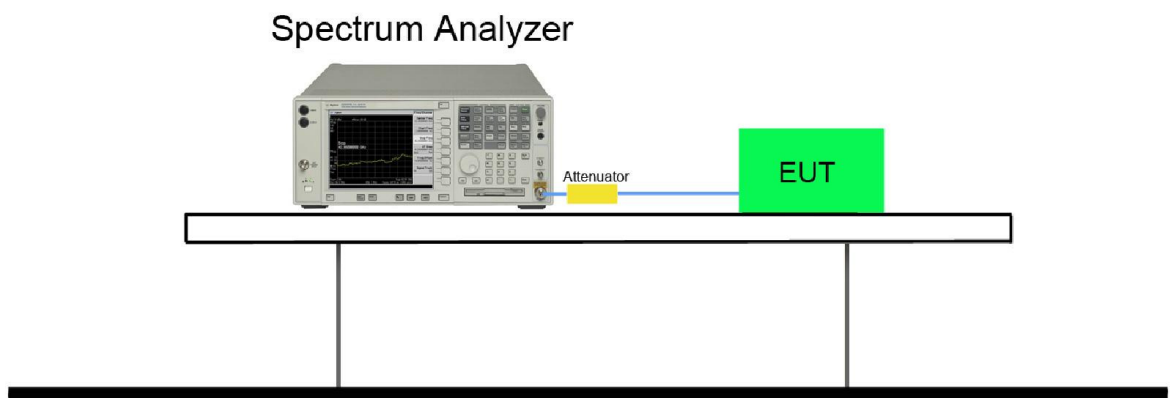

7.4.5. Test Result

Test Mode	Data Rate (Mbps)	Channel No.	Frequency (MHz)	Measured PSD (dBm / 3kHz)	Limit (dBm / 3kHz)	Result
802.11b	1	01	2412	-20.39	≤ 8	Pass
802.11b	1	06	2437	-20.41	≤ 8	Pass
802.11b	1	11	2462	-21.14	≤ 8	Pass
802.11g	6	01	2412	-19.77	≤ 8	Pass
802.11g	6	06	2437	-19.51	≤ 8	Pass
802.11g	6	11	2462	-19.96	≤ 8	Pass
802.11n-HT20	6.5	01	2412	-19.61	≤ 8	Pass
802.11n-HT20	6.5	06	2437	-19.30	≤ 8	Pass
802.11n-HT20	6.5	11	2462	-19.48	≤ 8	Pass
802.11n-HT40	13.5	03	2422	-19.06	≤ 8	Pass
802.11n-HT40	13.5	06	2437	-19.35	≤ 8	Pass
802.11n-HT40	13.5	09	2452	-19.00	≤ 8	Pass

802.11b PSD

Channel 01 (2412MHz)



Channel 06 (2437MHz)



Channel 11 (2462MHz)



802.11g PSD

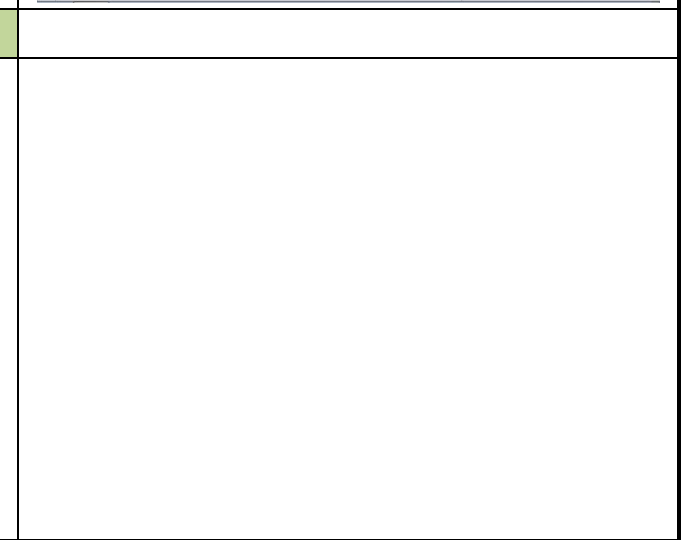
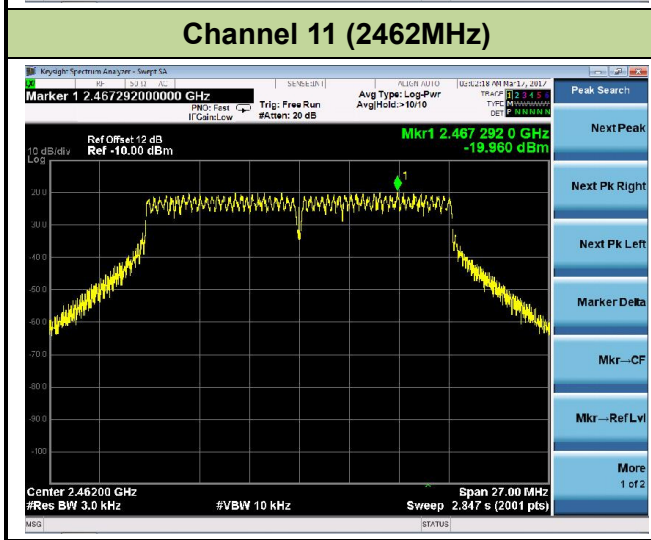
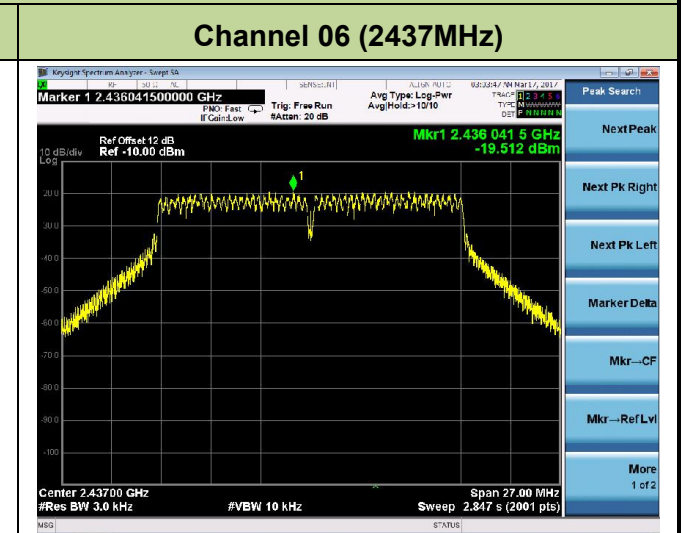
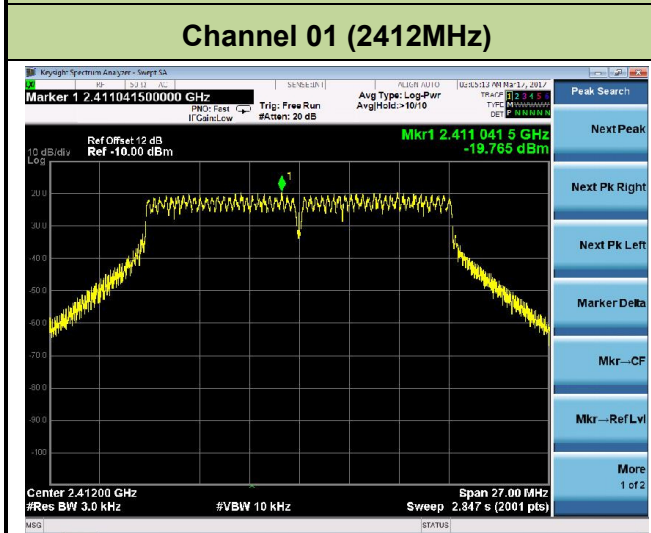

802.11n-HT20 PSD

Channel 01 (2412MHz)

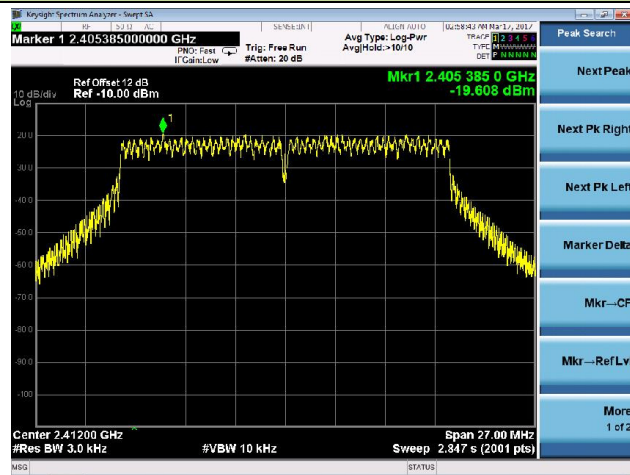

Channel 06 (2437MHz)

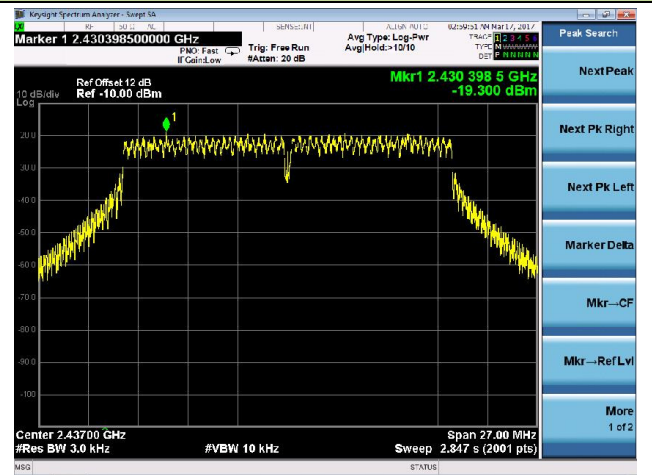

Channel 11 (2462MHz)

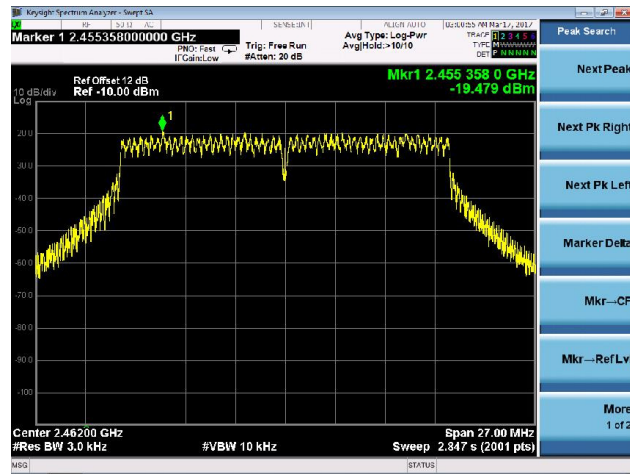

802.11n-HT40 PSD

Channel 03 (2422MHz)

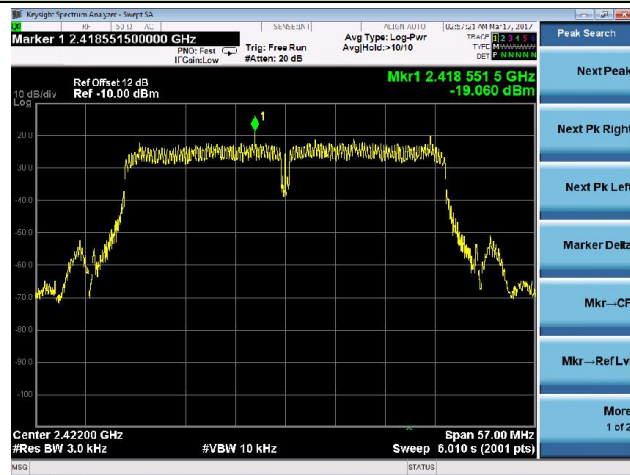

Channel 06 (2437MHz)



Channel 09 (2452MHz)

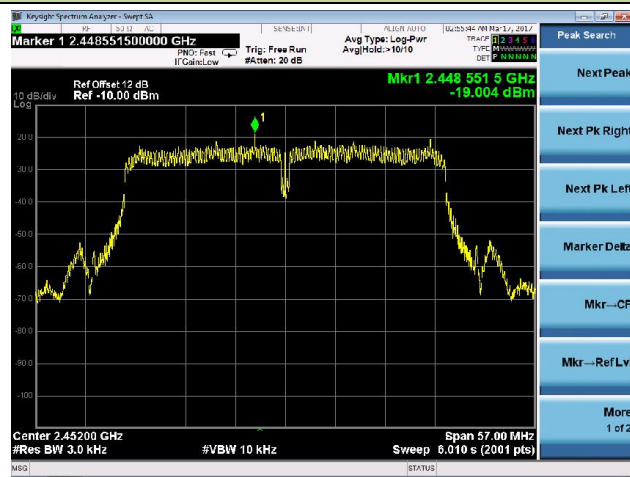

7.5. Conducted Band Edge and Out-of-Band Emissions

7.5.1. Test Limit

The limit for out-of-band spurious emissions at the band edge is 30dB below the fundamental emission level, as determined from the in-band power measurement of the DTS channel performed in a 100kHz bandwidth per the PSD procedure.

7.5.2. Test Procedure Used

KDB 558074 D01v03r05 - Section 11.2 & Section 11.3

7.5.3. Test Settling

1. Reference level measurement

- (a) Set instrument center frequency to DTS channel center frequency
- (b) Set the span to ≥ 1.5 times the DTS bandwidth
- (c) Set the RBW = 100 kHz
- (d) Set the VBW $\geq 3 \times$ RBW
- (e) Detector = peak
- (f) Sweep time = auto couple
- (g) Trace mode = max hold
- (h) Allow trace to fully stabilize

2. Emission level measurement

- (a) Set the center frequency and span to encompass frequency range to be measured
- (b) RBW = 100kHz
- (c) VBW = 300kHz
- (d) Detector = Peak
- (e) Trace mode = max hold
- (f) Sweep time = auto couple
- (g) The trace was allowed to stabilize

7.5.4. Test Setup

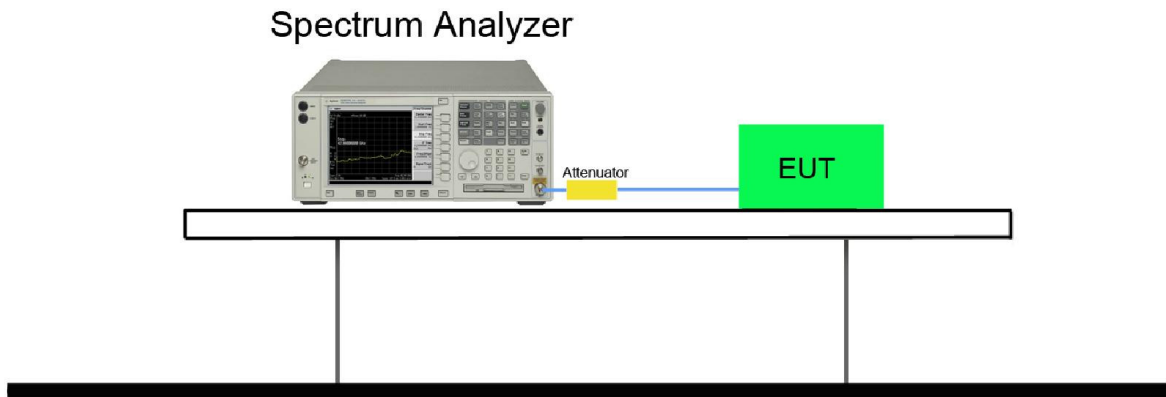

7.5.5. Test Result

Test Mode	Data Rate (Mbps)	Channel No.	Frequency (MHz)	Limit	Result
802.11b	1	01	2412	20dBc	Pass
802.11b	1	06	2437	20dBc	Pass
802.11b	1	11	2462	20dBc	Pass
802.11g	6	01	2412	20dBc	Pass
802.11g	6	06	2437	20dBc	Pass
802.11g	6	11	2462	20dBc	Pass
802.11n-HT20	6.5	01	2412	20dBc	Pass
802.11n-HT20	6.5	06	2437	20dBc	Pass
802.11n-HT20	6.5	11	2462	20dBc	Pass
802.11n-HT40	13.5	03	2422	20dBc	Pass
802.11n-HT40	13.5	06	2437	20dBc	Pass
802.11n-HT40	13.5	09	2452	20dBc	Pass

802.11b Out-of-Band Emissions

Channel 01 (2412MHz)

100kHz PSD reference Level



Low Band Edge

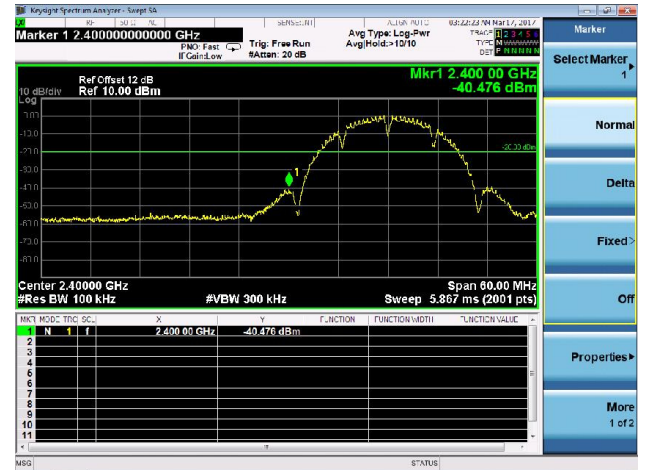

Spurious Emission

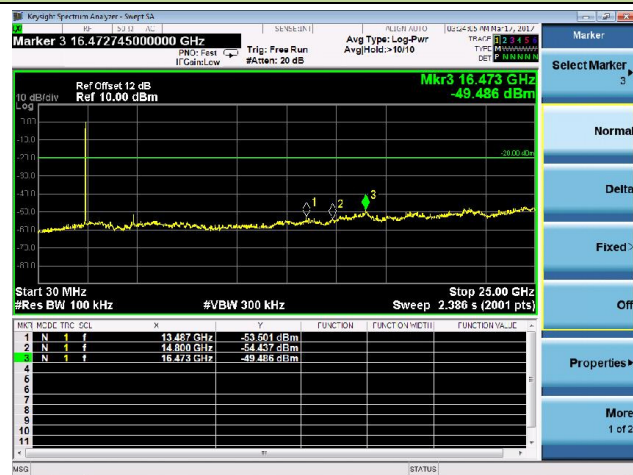

Channel 06 (2437MHz)

100kHz PSD reference Level



Spurious Emission



Channel 11 (2462MHz)

100kHz PSD reference Level



High Band Edge

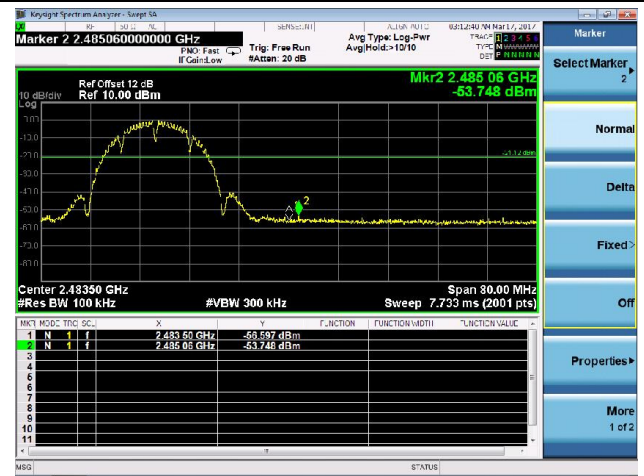

Spurious Emission



802.11g Out-of-Band Emissions

Channel 01 (2412MHz)

100kHz PSD reference Level



Low Band Edge

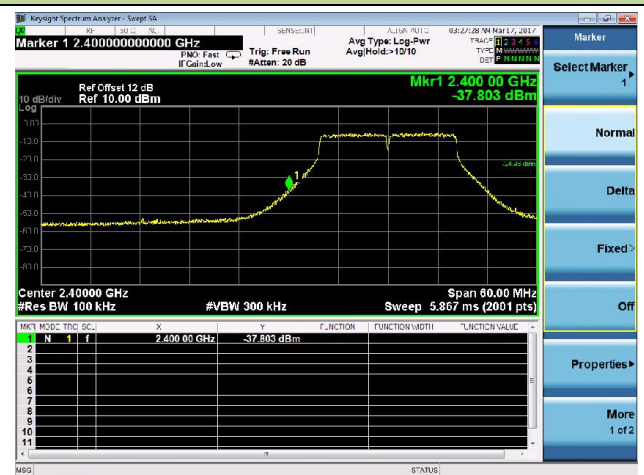

Spurious Emission

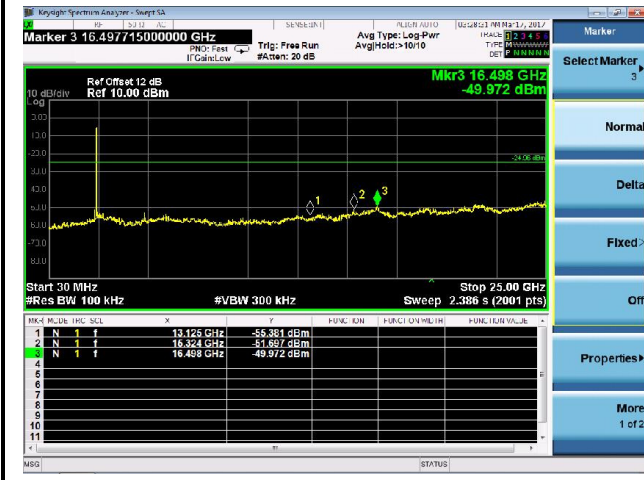

Channel 06 (2437MHz)

100kHz PSD reference Level



Spurious Emission

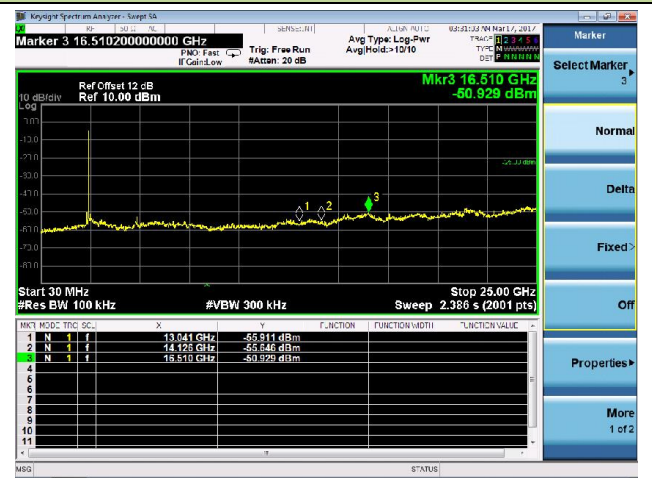

Channel 11 (2462MHz)

100kHz PSD reference Level

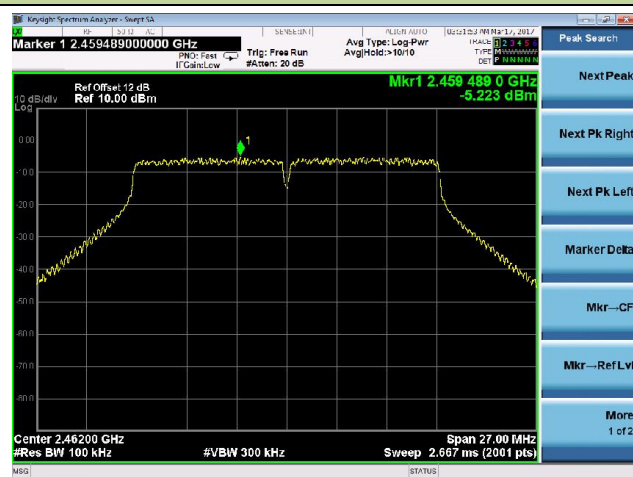

High Band Edge

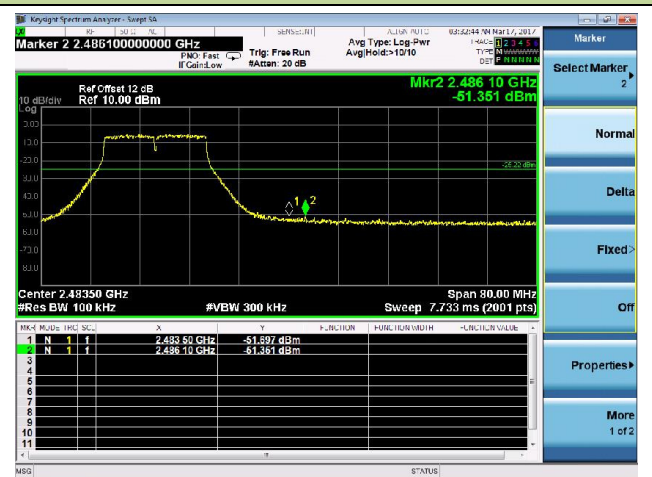

Spurious Emission

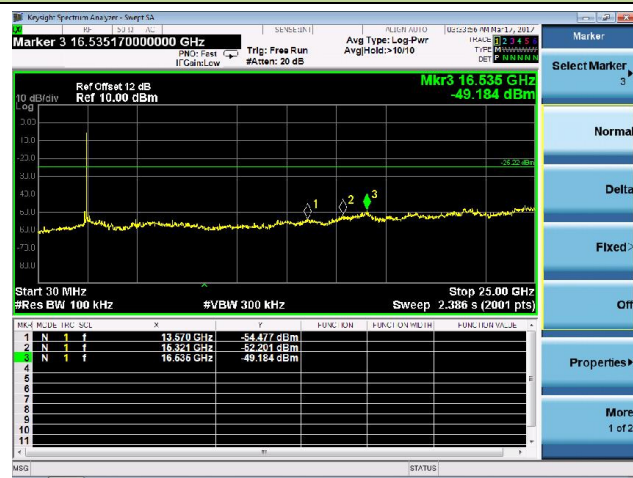

802.11n-HT20 Out-of-Band Emissions

Channel 01 (2412MHz)

100kHz PSD reference Level



Low Band Edge

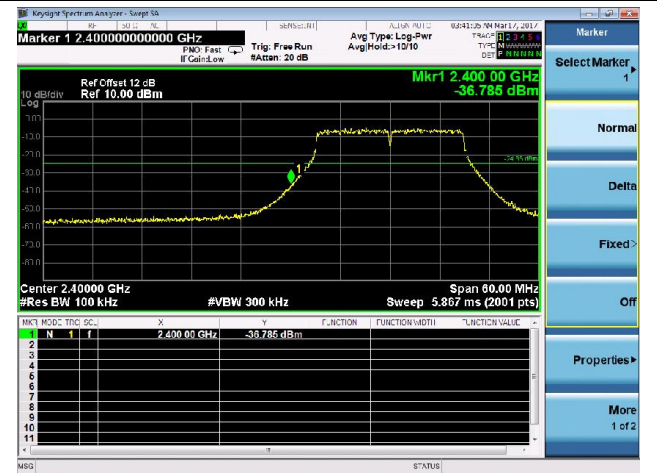

Spurious Emission

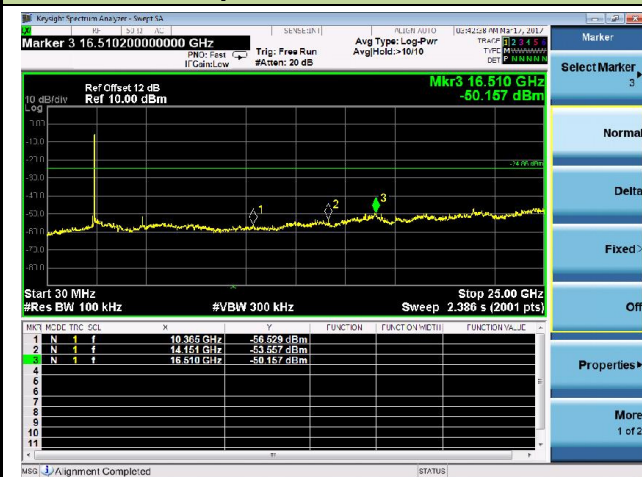

Channel 06 (2437MHz)

100kHz PSD reference Level



Spurious Emission

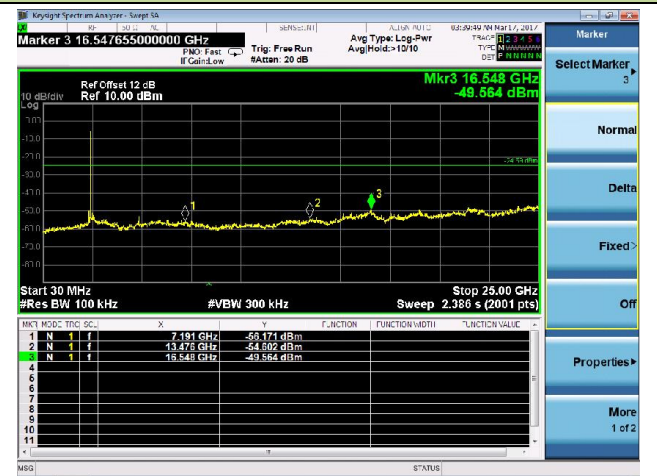

Channel 11 (2462MHz)

100kHz PSD reference Level



High Band Edge

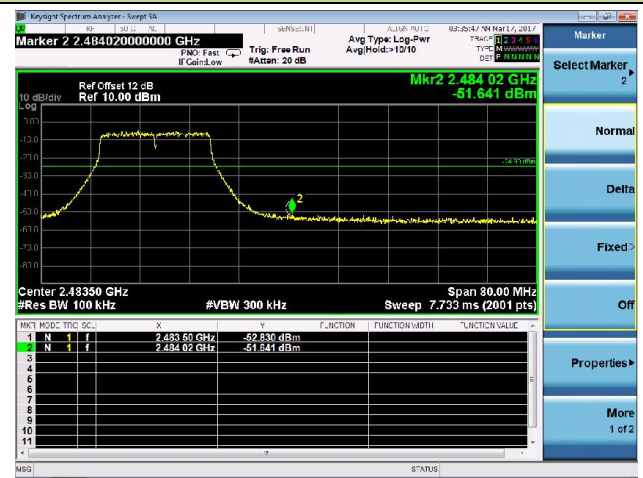

Spurious Emission



802.11n-HT40 Out-of-Band Emissions

Channel 03 (2422MHz)

100kHz PSD reference Level



Low Band Edge

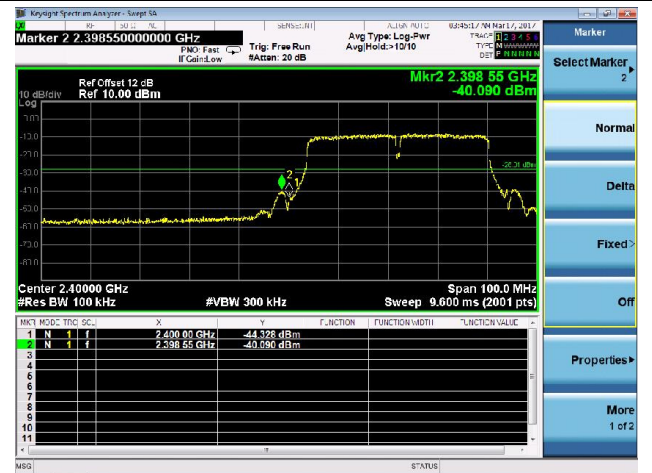

Spurious Emission

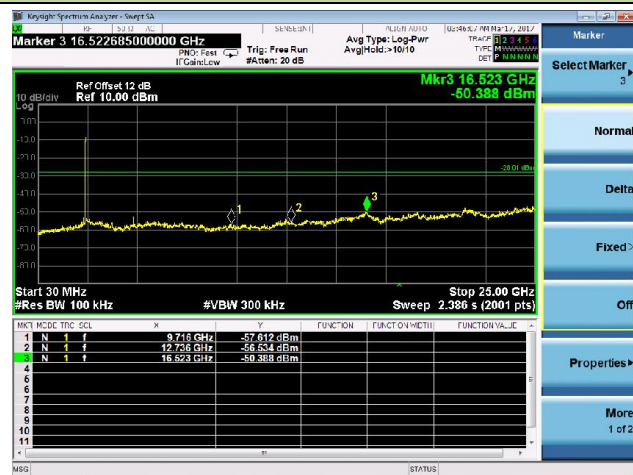

Channel 06 (2437MHz)

100kHz PSD reference Level



Spurious Emission



Channel 09 (2452MHz)

100kHz PSD reference Level



High Band Edge



Spurious Emission

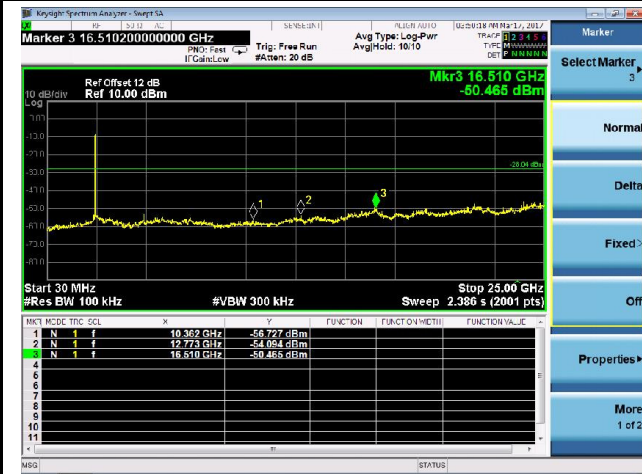

7.6. Radiated Spurious Emission Measurement

7.6.1. Test Limit

All out of band emissions appearing in a restricted band as specified in Section 15.205 of the Title 47 CFR must not exceed the limits shown in Table per Section 15.209.

FCC Part 15 Subpart C Paragraph 15.209		
Frequency [MHz]	Field Strength [V/m]	Measured Distance [Meters]
0.009 - 0.490	2400/F (kHz)	300
0.490 - 1.705	24000/F (kHz)	30
1.705 - 30	30	30
30 - 88	100	3
88 - 216	150	3
216 - 960	200	3
Above 960	500	3

7.6.2. Test Procedure Used

KDB 558074 D01v03r05 - Section 12.2.3 (quasi-peak measurements)

KDB 558074 D01v03r05 - Section 12.2.4 (peak power measurements)

KDB 558074 D01v03r05 - Section 12.2.5 (average power measurements)

7.6.3. Test Setting

Peak Field Strength Measurements

1. Analyzer center frequency was set to the frequency of the radiated spurious emission of interest
2. RBW = as specified in Table 1
3. VBW = 3MHz
4. Detector = peak

5. Sweep time = auto couple
6. Trace mode = max hold
7. Trace was allowed to stabilize

Table 1 - RBW as a function of frequency

Frequency	RBW
9 ~ 150 kHz	200 ~ 300 Hz
0.15 ~ 30 MHz	9 ~ 10 kHz
30 ~ 1000 MHz	100 ~ 120 kHz
> 1000 MHz	1 MHz

Average Field Strength Measurements

1. Analyzer center frequency was set to the frequency of the radiated spurious emission of interest
2. RBW = 1MHz
3. VBW \geq 1/T
4. De As an alternative, the instrument may be set to linear detector mode. Ensure that video filtering is applied in linear voltage domain (rather than in a log or dB domain). Some instruments require linear display mode in order to accomplish this. Others have a setting for Average-VBW Type, which can be set to "Voltage" regardless of the display mode
5. Detector = Peak
6. Sweep time = auto
7. Trace mode = max hold
8. Allow max hold to run for at least 50 times (1/duty cycle) traces

7.6.4. Test Setup

9kHz ~ 30MHz Test Setup:

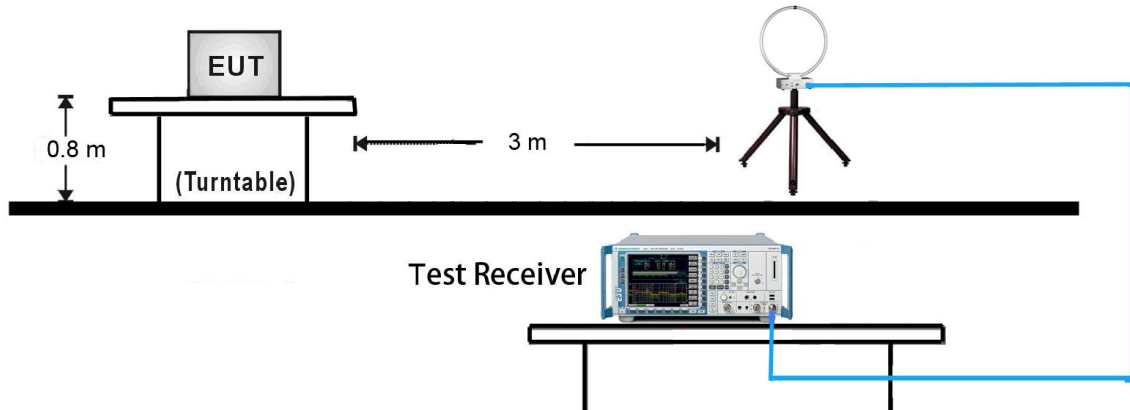

30MHz ~ 1GHz Test Setup:

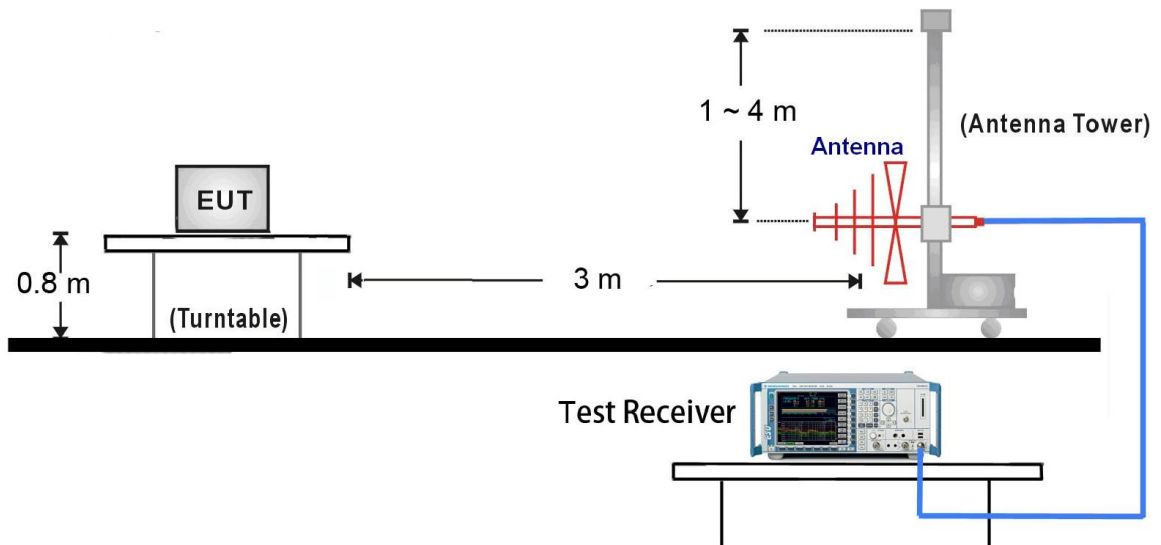

1GHz ~ 18GHz Test Setup:

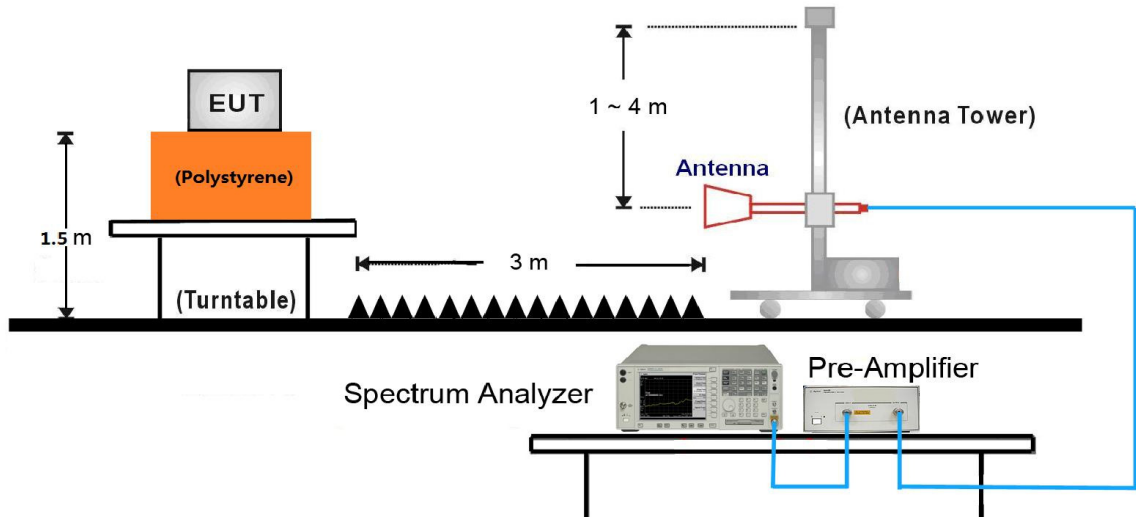

18GHz ~ 25GHz Test Setup:

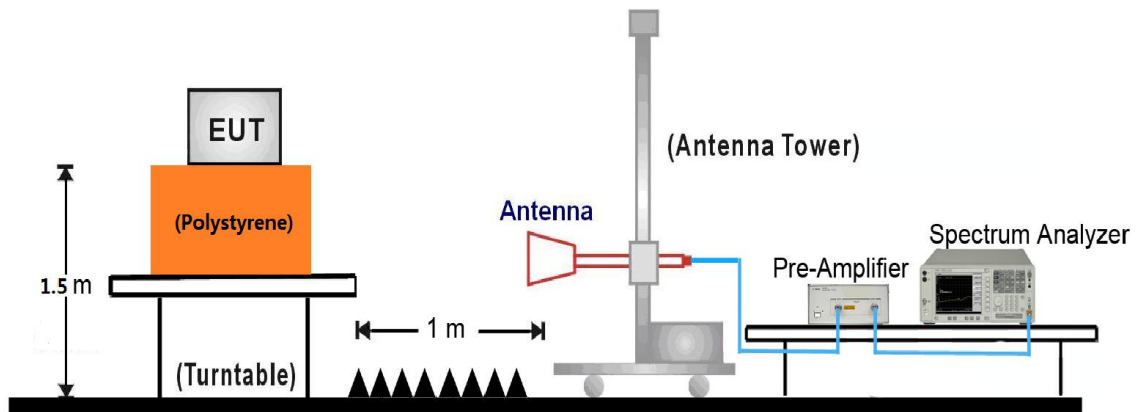

7.6.5. Test Result

Test Mode:	802.11b	Test Site:	AC2
Test Channel:	01	Test Engineer:	Snake Ni
Remark:	1. Average measurement was not performed if peak level lower than average limit. 2. Other frequency was 20dB below limit line within 1-18GHz, there is not show in the report.		

Mark	Frequency (MHz)	Reading Level (dB μ V)	Factor (dB)	Measure Level (dB μ V/m)	Limit (dB μ V/m)	Margin (dB)	Detector	Polarization
	4825.0	36.8	2.7	39.5	74.0	-34.5	Peak	Horizontal
	8140.0	31.8	10.6	42.4	74.0	-31.6	Peak	Horizontal
*	10205.5	32.2	14.0	46.2	82.2	-36.0	Peak	Horizontal
*	12934.0	31.5	17.1	48.6	82.2	-33.6	Peak	Horizontal
	4825.0	35.4	2.7	38.1	74.0	-35.9	Peak	Vertical
	7536.5	32.3	11.0	43.3	74.0	-30.7	Peak	Vertical
*	8913.5	30.8	11.9	42.7	82.2	-39.5	Peak	Vertical
*	9840.0	31.4	13.5	44.9	82.2	-37.3	Peak	Vertical

Note 1: "*" is not in restricted band, its limit is 30dBc of the fundamental emission level (102.2dB μ V/m) or 15.209 which is higher.

Note 2: Measure Level (dB μ V/m) = Reading Level (dB μ V) + Factor (dB)

Factor (dB) = Cable Loss (dB) + Antenna Factor (dB/m) - Pre_Amplifier Gain (dB)

Test Mode:	802.11b	Test Site:	AC2
Test Channel:	06	Test Engineer:	Snake Ni
Remark:	1. Average measurement was not performed if peak level lower than average limit. 2. Other frequency was 20dB below limit line within 1-18GHz, there is not show in the report.		

Mark	Frequency (MHz)	Reading Level (dBμV)	Factor (dB)	Measure Level (dBμV/m)	Limit (dBμV/m)	Margin (dB)	Detector	Polarization
	4876.0	37.6	2.6	40.2	74.0	-33.8	Peak	Horizontal
	7375.0	32.5	10.8	43.3	74.0	-30.7	Peak	Horizontal
*	8599.0	32.6	11.0	43.6	81.3	-37.7	Peak	Horizontal
*	9729.5	33.2	12.4	45.6	81.3	-35.7	Peak	Horizontal
	4876.0	38.3	2.6	40.9	74.0	-33.1	Peak	Vertical
	5437.0	35.4	3.3	38.7	74.0	-35.3	Peak	Vertical
*	8701.0	33.1	11.4	44.5	81.3	-36.8	Peak	Vertical
*	9772.0	33.3	12.6	45.9	81.3	-35.4	Peak	Vertical

Note 1: "*" is not in restricted band, its limit is 30dBc of the fundamental emission level (101.3dBμV/m) or 15.209 which is higher.

Note 2: Measure Level (dBμV/m) = Reading Level (dBμV) + Factor (dB)

Factor (dB) = Cable Loss (dB) + Antenna Factor (dB/m) - Pre_Amplifier Gain (dB)

Test Mode:	802.11b	Test Site:	AC2
Test Channel:	11	Test Engineer:	Snake Ni
Remark:	1. Average measurement was not performed if peak level lower than average limit. 2. Other frequency was 20dB below limit line within 1-18GHz, there is not show in the report.		

Mark	Frequency (MHz)	Reading Level (dBμV)	Factor (dB)	Measure Level (dBμV/m)	Limit (dBμV/m)	Margin (dB)	Detector	Polarization
	4927.0	36.9	2.6	39.5	74.0	-34.5	Peak	Horizontal
	7519.5	32.9	10.9	43.8	74.0	-30.2	Peak	Horizontal
*	8607.5	32.5	11.1	43.6	80.2	-36.6	Peak	Horizontal
*	9712.5	32.8	12.3	45.1	80.2	-35.1	Peak	Horizontal
	4927.0	37.9	2.6	40.5	74.0	-33.5	Peak	Vertical
	7511.0	32.6	11.0	43.6	74.0	-30.4	Peak	Vertical
*	8854.0	31.3	11.7	43.0	80.2	-37.2	Peak	Vertical
*	9899.5	31.7	13.3	45.0	80.2	-35.2	Peak	Vertical

Note 1: "*" is not in restricted band, its limit is 30dBc of the fundamental emission level (100.2dBμV/m) or 15.209 which is higher.

Note 2: Measure Level (dBμV/m) = Reading Level (dBμV) + Factor (dB)

Factor (dB) = Cable Loss (dB) + Antenna Factor (dB/m) - Pre_Amplifier Gain (dB)

Test Mode:	802.11g	Test Site:	AC2
Test Channel:	01	Test Engineer:	Snake Ni
Remark:	1. Average measurement was not performed if peak level lower than average limit. 2. Other frequency was 20dB below limit line within 1-18GHz, there is not show in the report.		

Mark	Frequency (MHz)	Reading Level (dBμV)	Factor (dB)	Measure Level (dBμV/m)	Limit (dBμV/m)	Margin (dB)	Detector	Polarization
	4825.0	36.2	2.7	38.9	74.0	-35.1	Peak	Horizontal
	7409.0	32.3	10.8	43.1	74.0	-30.9	Peak	Horizontal
*	8871.0	31.6	11.5	43.1	82.2	-39.1	Peak	Horizontal
*	9848.5	31.4	13.3	44.7	82.2	-37.5	Peak	Horizontal
	4825.0	35.7	2.7	38.4	74.0	-35.6	Peak	Vertical
	7460.0	32.7	11.1	43.8	74.0	-30.2	Peak	Vertical
*	8905.0	30.7	12.0	42.7	82.2	-39.5	Peak	Vertical
*	9882.5	33.6	13.3	46.9	82.2	-35.3	Peak	Vertical

Note 1: "*" is not in restricted band, its limit is 30dBc of the fundamental emission level (102.2dBμV/m) or 15.209 which is higher.

Note 2: Measure Level (dBμV/m) = Reading Level (dBμV) + Factor (dB)

Factor (dB) = Cable Loss (dB) + Antenna Factor (dB/m) - Pre_Amplifier Gain (dB)

Test Mode:	802.11g	Test Site:	AC2
Test Channel:	06	Test Engineer:	Snake Ni
Remark:	1. Average measurement was not performed if peak level lower than average limit. 2. Other frequency was 20dB below limit line within 1-18GHz, there is not show in the report.		

Mark	Frequency (MHz)	Reading Level (dBμV)	Factor (dB)	Measure Level (dBμV/m)	Limit (dBμV/m)	Margin (dB)	Detector	Polarization
	4876.0	36.1	2.6	38.7	74.0	-35.3	Peak	Horizontal
	7264.5	33.2	10.7	43.9	74.0	-30.1	Peak	Horizontal
*	8913.5	30.8	11.9	42.7	81.8	-39.1	Peak	Horizontal
*	9721.0	33.0	12.3	45.3	81.8	-36.5	Peak	Horizontal
	4876.0	36.4	2.6	39.0	74.0	-35.0	Peak	Vertical
	7332.5	32.2	10.7	42.9	74.0	-31.1	Peak	Vertical
*	8777.5	31.2	11.9	43.1	81.8	-38.7	Peak	Vertical
*	9950.5	31.9	13.5	45.4	81.8	-36.4	Peak	Vertical

Note 1: "*" is not in restricted band, its limit is 30dBc of the fundamental emission level (101.8dBμV/m) or 15.209 which is higher.

Note 2: Measure Level (dBμV/m) = Reading Level (dBμV) + Factor (dB)

Factor (dB) = Cable Loss (dB) + Antenna Factor (dB/m) - Pre_Amplifier Gain (dB)

Test Mode:	802.11g	Test Site:	AC2
Test Channel:	11	Test Engineer:	Snake Ni
Remark:	1. Average measurement was not performed if peak level lower than average limit. 2. Other frequency was 20dB below limit line within 1-18GHz, there is not show in the report.		

Mark	Frequency (MHz)	Reading Level (dBμV)	Factor (dB)	Measure Level (dBμV/m)	Limit (dBμV/m)	Margin (dB)	Detector	Polarization
	4927.0	38.3	2.6	40.9	74.0	-33.1	Peak	Horizontal
	7451.5	32.3	10.9	43.2	74.0	-30.8	Peak	Horizontal
*	8590.5	31.9	11.0	42.9	81.6	-38.7	Peak	Horizontal
*	9899.5	31.8	13.3	45.1	81.6	-36.5	Peak	Horizontal
	4927.0	37.5	2.6	40.1	74.0	-33.9	Peak	Vertical
	7451.5	31.7	10.9	42.6	74.0	-31.4	Peak	Vertical
*	8786.0	31.9	11.8	43.7	81.6	-37.9	Peak	Vertical
*	9721.0	32.9	12.3	45.2	81.6	-36.4	Peak	Vertical

Note 1: "*" is not in restricted band, its limit is 30dBc of the fundamental emission level (101.6dBμV/m) or 15.209 which is higher.

Note 2: Measure Level (dBμV/m) = Reading Level (dBμV) + Factor (dB)

Factor (dB) = Cable Loss (dB) + Antenna Factor (dB/m) - Pre_Amplifier Gain (dB)

Test Mode:	802.11n-HT20	Test Site:	AC2
Test Channel:	01	Test Engineer:	Snake Ni
Remark:	1. Average measurement was not performed if peak level lower than average limit. 2. Other frequency was 20dB below limit line within 1-18GHz, there is not show in the report.		

Mark	Frequency (MHz)	Reading Level (dBμV)	Factor (dB)	Measure Level (dBμV/m)	Limit (dBμV/m)	Margin (dB)	Detector	Polarization
	4825.0	37.6	2.7	40.3	74.0	-33.7	Peak	Horizontal
	7400.5	32.2	10.8	43.0	74.0	-31.0	Peak	Horizontal
*	8777.5	32.1	11.9	44.0	81.9	-37.9	Peak	Horizontal
*	9627.5	32.8	12.7	45.5	81.9	-36.4	Peak	Horizontal
	4825.0	38.0	2.7	40.7	74.0	-33.3	Peak	Vertical
	7519.5	34.3	10.9	45.2	74.0	-28.8	Peak	Vertical
*	8701.0	32.7	11.4	44.1	81.9	-37.8	Peak	Vertical
*	9908.0	32.7	13.5	46.2	81.9	-35.7	Peak	Vertical

Note 1: "*" is not in restricted band, its limit is 30dBc of the fundamental emission level (101.9dBμV/m) or 15.209 which is higher.

Note 2: Measure Level (dBμV/m) = Reading Level (dBμV) + Factor (dB)

Factor (dB) = Cable Loss (dB) + Antenna Factor (dB/m) - Pre_Amplifier Gain (dB)

Test Mode:	802.11n-HT20	Test Site:	AC2
Test Channel:	06	Test Engineer:	Snake Ni
Remark:	1. Average measurement was not performed if peak level lower than average limit. 2. Other frequency was 20dB below limit line within 1-18GHz, there is not show in the report.		

Mark	Frequency (MHz)	Reading Level (dBμV)	Factor (dB)	Measure Level (dBμV/m)	Limit (dBμV/m)	Margin (dB)	Detector	Polarization
	4876.0	36.9	2.6	39.5	74.0	-34.5	Peak	Horizontal
	7519.5	33.0	10.9	43.9	74.0	-30.1	Peak	Horizontal
*	8675.5	31.0	11.2	42.2	81.9	-39.7	Peak	Horizontal
*	9967.5	32.9	13.2	46.1	81.9	-35.8	Peak	Horizontal
	4876.0	37.7	2.6	40.3	74.0	-33.7	Peak	Vertical
	7494.0	33.0	11.0	44.0	74.0	-30.0	Peak	Vertical
*	8624.5	31.9	11.2	43.1	81.9	-38.8	Peak	Vertical
*	9661.5	33.1	12.5	45.6	81.9	-36.3	Peak	Vertical

Note 1: "*" is not in restricted band, its limit is 30dBc of the fundamental emission level (101.9dBμV/m) or 15.209 which is higher.

Note 2: Measure Level (dBμV/m) = Reading Level (dBμV) + Factor (dB)

Factor (dB) = Cable Loss (dB) + Antenna Factor (dB/m) - Pre_Amplifier Gain (dB)

Test Mode:	802.11n-HT20	Test Site:	AC2
Test Channel:	11	Test Engineer:	Snake Ni
Remark:	1. Average measurement was not performed if peak level lower than average limit. 2. Other frequency was 20dB below limit line within 1-18GHz, there is not show in the report.		

Mark	Frequency (MHz)	Reading Level (dBμV)	Factor (dB)	Measure Level (dBμV/m)	Limit (dBμV/m)	Margin (dB)	Detector	Polarization
	4927.0	37.6	2.6	40.2	74.0	-33.8	Peak	Horizontal
	7281.5	32.7	10.6	43.3	74.0	-30.7	Peak	Horizontal
*	8896.5	31.6	11.7	43.3	81.9	-38.6	Peak	Horizontal
*	9916.5	32.8	13.4	46.2	81.9	-35.7	Peak	Horizontal
	4927.0	38.5	2.6	41.1	74.0	-32.9	Peak	Vertical
	7451.5	32.3	10.9	43.2	74.0	-30.8	Peak	Vertical
*	8616.0	31.5	11.2	42.7	81.9	-39.2	Peak	Vertical
*	9721.0	33.1	12.3	45.4	81.9	-36.5	Peak	Vertical

Note 1: "*" is not in restricted band, its limit is 30dBc of the fundamental emission level (101.9dBμV/m) or 15.209 which is higher.

Note 2: Measure Level (dBμV/m) = Reading Level (dBμV) + Factor (dB)

Factor (dB) = Cable Loss (dB) + Antenna Factor (dB/m) - Pre_Amplifier Gain (dB)

Test Mode:	802.11n-HT40	Test Site:	AC2
Test Channel:	03	Test Engineer:	Snake Ni
Remark:	1. Average measurement was not performed if peak level lower than average limit. 2. Other frequency was 20dB below limit line within 1-18GHz, there is not show in the report.		

Mark	Frequency (MHz)	Reading Level (dBμV)	Factor (dB)	Measure Level (dBμV/m)	Limit (dBμV/m)	Margin (dB)	Detector	Polarization
	4842.0	37.3	2.9	40.2	74.0	-33.8	Peak	Horizontal
	7383.5	32.3	10.7	43.0	74.0	-31.0	Peak	Horizontal
*	9576.5	32.2	12.8	45.0	78.9	-33.9	Peak	Horizontal
*	10248.0	31.5	14.3	45.8	78.9	-33.1	Peak	Horizontal
	4842.0	37.1	2.9	40.0	74.0	-34.0	Peak	Vertical
	7460.0	32.2	11.1	43.3	74.0	-30.7	Peak	Vertical
*	9610.5	32.5	12.5	45.0	78.9	-33.9	Peak	Vertical
*	10256.5	32.0	14.3	46.3	78.9	-32.6	Peak	Vertical

Note 1: "*" is not in restricted band, its limit is 30dBc of the fundamental emission level (98.9dBμV/m) or 15.209 which is higher.

Note 2: Measure Level (dBμV/m) = Reading Level (dBμV) + Factor (dB)

Factor (dB) = Cable Loss (dB) + Antenna Factor (dB/m) - Pre_Amplifier Gain (dB)

Test Mode:	802.11n-HT40	Test Site:	AC2
Test Channel:	06	Test Engineer:	Snake Ni
Remark:	1. Average measurement was not performed if peak level lower than average limit. 2. Other frequency was 20dB below limit line within 1-18GHz, there is not show in the report.		

Mark	Frequency (MHz)	Reading Level (dBμV)	Factor (dB)	Measure Level (dBμV/m)	Limit (dBμV/m)	Margin (dB)	Detector	Polarization
	4876.0	37.3	2.6	39.9	74.0	-34.1	Peak	Horizontal
	7511.0	32.7	11.0	43.7	74.0	-30.3	Peak	Horizontal
*	9721.0	33.4	12.3	45.7	78.9	-33.2	Peak	Horizontal
*	10248.0	32.3	14.3	46.6	78.9	-32.3	Peak	Horizontal
	4876.0	38.0	2.6	40.6	74.0	-33.4	Peak	Vertical
	7451.5	32.7	10.9	43.6	74.0	-30.4	Peak	Vertical
*	9687.0	33.5	12.5	46.0	78.9	-32.9	Peak	Vertical
*	10231.0	32.1	14.4	46.5	78.9	-32.4	Peak	Vertical

Note 1: "*" is not in restricted band, its limit is 30dBc of the fundamental emission level (98.9dBμV/m) or 15.209 which is higher.

Note 2: Measure Level (dBμV/m) = Reading Level (dBμV) + Factor (dB)

Factor (dB) = Cable Loss (dB) + Antenna Factor (dB/m) - Pre_Amplifier Gain (dB)

Test Mode:	802.11n-HT40	Test Site:	AC2
Test Channel:	09	Test Engineer:	Snake Ni
Remark:	1. Average measurement was not performed if peak level lower than average limit. 2. Other frequency was 20dB below limit line within 1-18GHz, there is not show in the report.		

Mark	Frequency (MHz)	Reading Level (dBμV)	Factor (dB)	Measure Level (dBμV/m)	Limit (dBμV/m)	Margin (dB)	Detector	Polarization
	4901.5	38.4	2.6	41.0	74.0	-33.0	Peak	Horizontal
	7613.0	32.7	10.8	43.5	74.0	-30.5	Peak	Horizontal
*	9678.5	32.0	12.5	44.5	78.8	-34.3	Peak	Horizontal
*	10129.0	32.9	13.6	46.5	78.8	-32.3	Peak	Horizontal
	4901.5	37.9	2.6	40.5	74.0	-33.5	Peak	Vertical
	7562.0	32.5	10.9	43.4	74.0	-30.6	Peak	Vertical
*	9755.0	33.4	13.0	46.4	78.8	-32.4	Peak	Vertical
*	10180.0	32.3	14.3	46.6	78.8	-32.2	Peak	Vertical

Note 1: "*" is not in restricted band, its limit is 30dBc of the fundamental emission level (98.8dBμV/m) or 15.209 which is higher.

Note 2: Measure Level (dBμV/m) = Reading Level (dBμV) + Factor (dB)

Factor (dB) = Cable Loss (dB) + Antenna Factor (dB/m) - Pre_Amplifier Gain (dB)

The worst case of Radiated Emission below 1GHz:

Site: AC2	Time: 2017/03/14 - 21:27
Limit: FCC_Part15.209_RE(3m)	Engineer: Snake Ni
Probe: VULB9162_0.03GHz_8GHz	Polarity: Horizontal
EUT: E-reader	Power: AC 120V/60Hz
Note: There is the worst case within frequency range 30MHz~1GHz.	

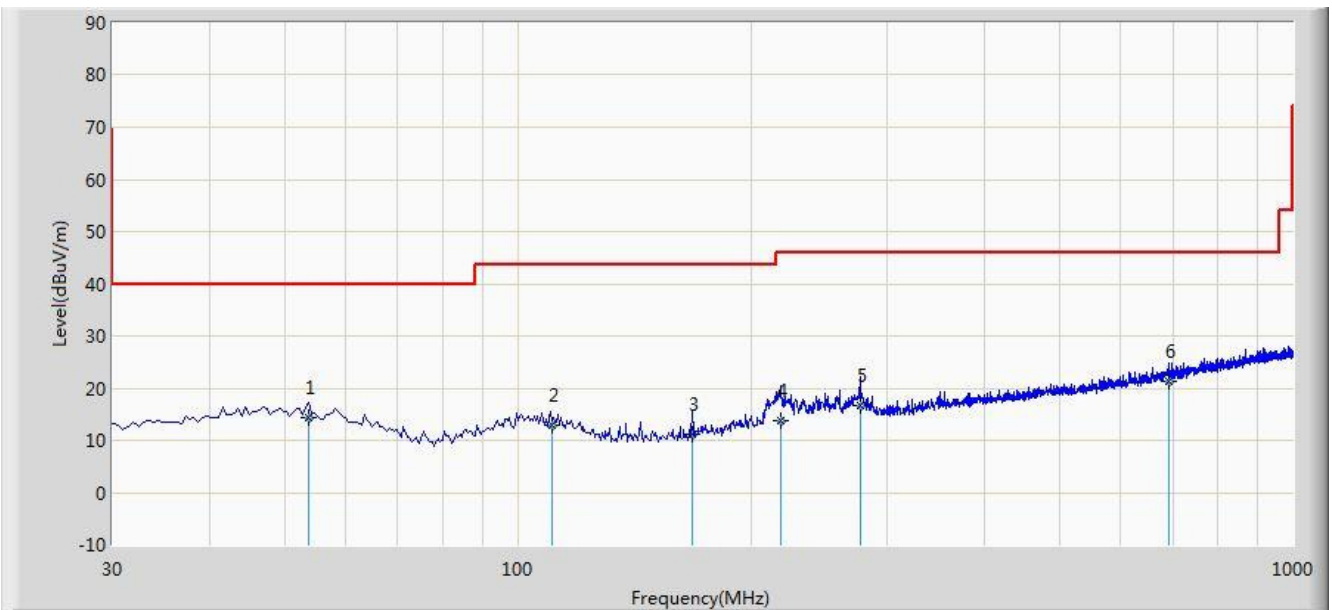

No	Flag	Mark	Frequency (MHz)	Measure Level (dBuV/m)	Reading Level (dBuV)	Over Limit (dB)	Limit (dBuV/m)	Factor (dB)	Type
1			53.810	14.472	-0.430	-25.528	40.000	14.901	QP
2			110.560	12.929	0.010	-30.571	43.500	12.919	QP
3			167.830	11.204	0.920	-32.296	43.500	10.284	QP
4			218.220	13.787	1.040	-32.213	46.000	12.746	QP
5			276.420	16.735	2.410	-29.265	46.000	14.326	QP
6		*	691.150	21.183	-0.520	-24.817	46.000	21.702	QP

Note 1: Measure Level (dB μ V/m) = Reading Level (dB μ V) + Factor (dB)

Factor (dB) = Cable Loss (dB) + Antenna Factor (dB/m)

Note 2: The test trace is same as the ambient noise and the amplitude of the emissions are attenuated more than 20dB below the permissible (the test frequency range: 9kHz ~ 30MHz, 18GHz ~ 25GHz), therefore no data appear in the report.

Site: AC2	Time: 2017/03/14 - 21:50
Limit: FCC_Part15.209_RE(3m)	Engineer: Snake Ni
Probe: VULB9162_0.03GHz_8GHz	Polarity: Vertical
EUT: E-reader	Power: AC 120V/60Hz
Note: There is the worst case within frequency range 30MHz~1GHz.	

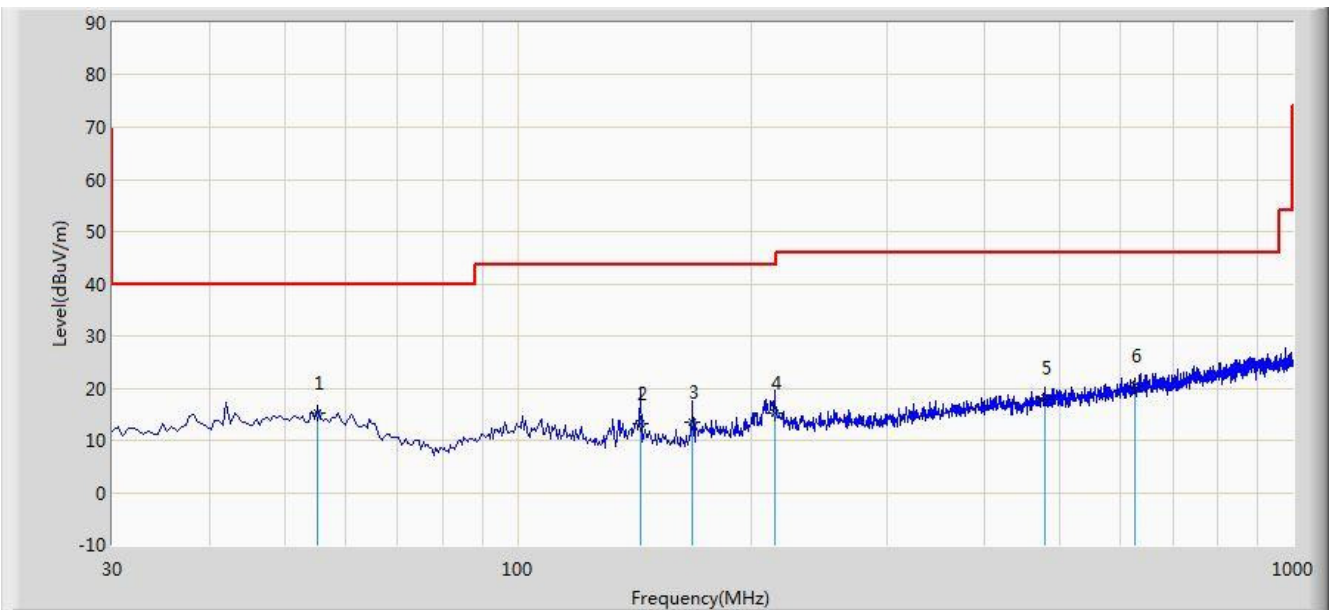

No	Flag	Mark	Frequency (MHz)	Measure Level (dBuV/m)	Reading Level (dBuV)	Over Limit (dB)	Limit (dBuV/m)	Factor (dB)	Type
1		*	55.280	15.219	0.540	-24.781	40.000	14.679	QP
2			143.850	13.097	3.540	-30.403	43.500	9.557	QP
3			168.230	13.343	3.040	-30.157	43.500	10.304	QP
4			214.280	15.196	2.550	-28.304	43.500	12.645	QP
5			479.620	18.184	-0.040	-27.816	46.000	18.224	QP
6			625.810	20.393	-0.240	-25.607	46.000	20.633	QP

Note 1: Measure Level (dBμV/m) = Reading Level (dBμV) + Factor (dB)

Factor (dB) = Cable Loss (dB) + Antenna Factor (dB/m)

Note 2: The test trace is same as the ambient noise and the amplitude of the emissions are attenuated more than 20dB below the permissible (the test frequency range: 9kHz ~ 30MHz, 18GHz ~ 25GHz), therefore no data appear in the report.

7.7. Radiated Restricted Band Edge Measurement

7.7.1. Test Result

Site: AC2	Time: 2017/03/18 - 01:37
Limit: FCC_Part15.209_RE(3m)	Engineer: Snake Ni
Probe: BBHA9120D_1-18GHz	Polarity: Horizontal
EUT: E-reader	Power: AC 120V/60Hz
Test Mode: Transmit by 802.11b at Channel 2412MHz	

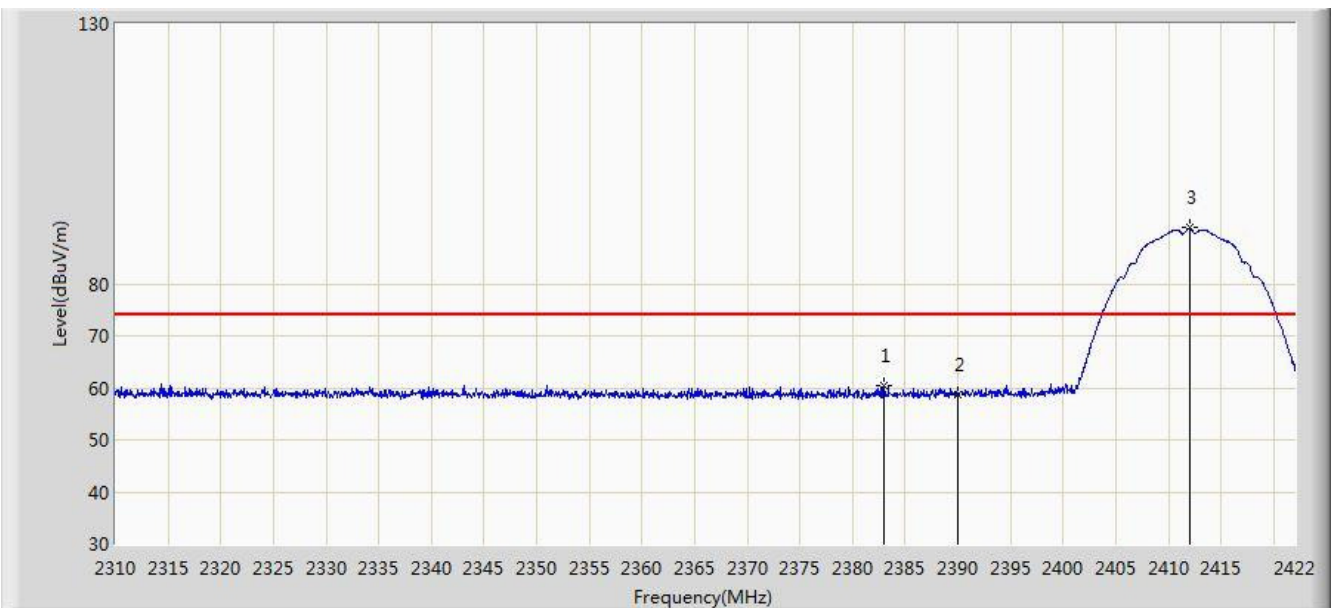

No	Flag	Mark	Frequency (MHz)	Measure Level (dBuV/m)	Reading Level (dBuV)	Over Limit (dB)	Limit (dBuV/m)	Factor (dB)	Type
1			2382.968	60.514	28.275	-13.486	74.000	32.239	PK
2			2390.000	58.695	26.417	-15.305	74.000	32.278	PK
3		*	2412.032	90.750	58.510	N/A	N/A	32.240	PK

Test Mode: Measure Level (dB μ V/m) = Reading Level (dB μ V) + Factor (dB)

Factor (dB) = Cable Loss (dB) + Antenna Factor (dB/m)

Site: AC2	Time: 2017/03/18 - 02:55
Limit: FCC_Part15.209_RE(3m)	Engineer: Snake Ni
Probe: BBHA9120D_1-18GHz	Polarity: Horizontal
EUT: E-reader	Power: AC 120V/60Hz
Test Mode: Transmit by 802.11b at Channel 2412MHz	



No	Flag	Mark	Frequency (MHz)	Measure Level (dBuV/m)	Reading Level (dBuV)	Over Limit (dB)	Limit (dBuV/m)	Factor (dB)	Type
1			2390.000	45.896	13.618	-8.104	54.000	32.278	AV
2		*	2411.136	86.424	54.181	N/A	N/A	32.243	AV

Test Mode: Measure Level (dBμV/m) = Reading Level (dBμV) + Factor (dB)

Factor (dB) = Cable Loss (dB) + Antenna Factor (dB/m)

Site: AC2	Time: 2017/03/18 - 02:55
Limit: FCC_Part15.209_RE(3m)	Engineer: Snake Ni
Probe: BBHA9120D_1-18GHz	Polarity: Vertical
EUT: E-reader	Power: AC 120V/60Hz
Test Mode: Transmit by 802.11b at Channel 2412MHz	

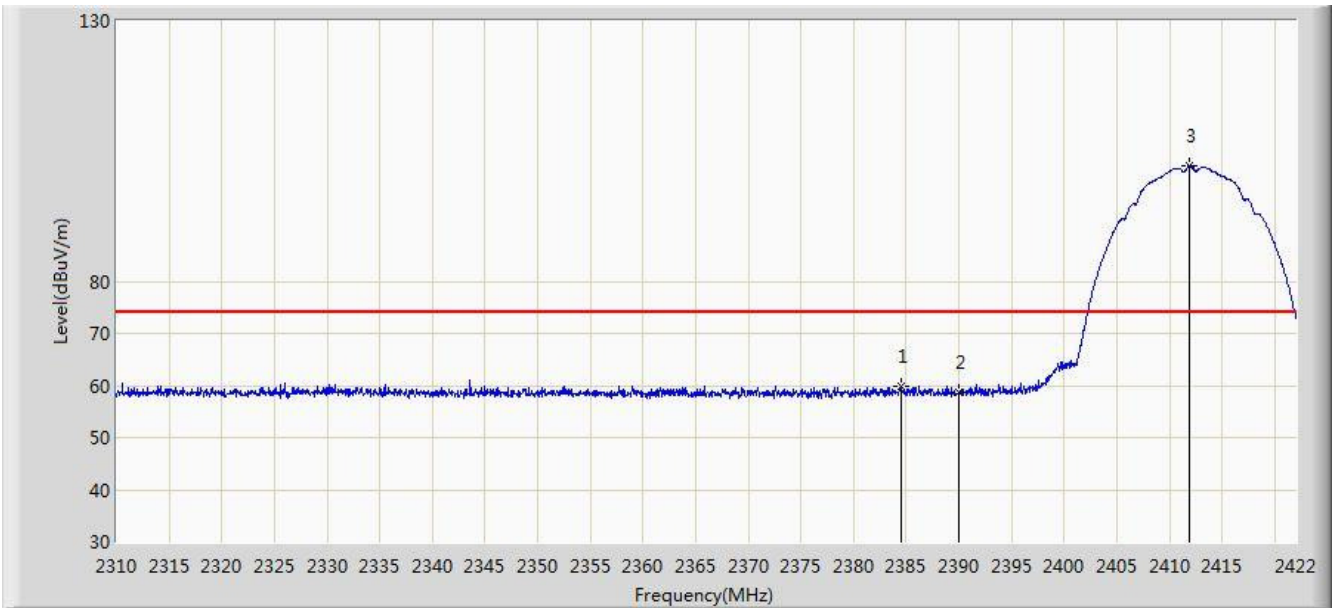

No	Flag	Mark	Frequency (MHz)	Measure Level (dBuV/m)	Reading Level (dBuV)	Over Limit (dB)	Limit (dBuV/m)	Factor (dB)	Type
1			2384.480	59.989	27.742	-14.011	74.000	32.247	PK
2			2390.000	58.776	26.498	-15.224	74.000	32.278	PK
3		*	2411.920	102.230	69.990	N/A	N/A	32.240	PK

Test Mode: Measure Level (dB μ V/m) = Reading Level (dB μ V) + Factor (dB)

Factor (dB) = Cable Loss (dB) + Antenna Factor (dB/m)

Site: AC2	Time: 2017/03/18 - 02:57
Limit: FCC_Part15.209_RE(3m)	Engineer: Snake Ni
Probe: BBHA9120D_1-18GHz	Polarity: Vertical
EUT: E-reader	Power: AC 120V/60Hz
Test Mode: Transmit by 802.11b at Channel 2412MHz	

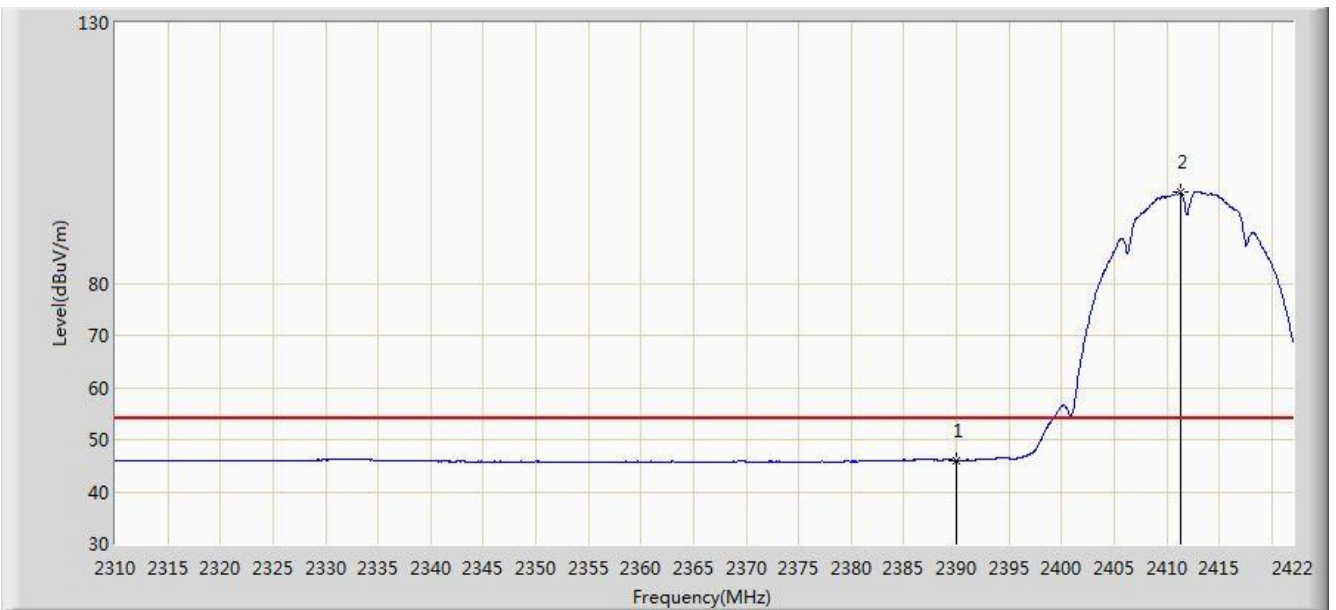

No	Flag	Mark	Frequency (MHz)	Measure Level (dBuV/m)	Reading Level (dBuV)	Over Limit (dB)	Limit (dBuV/m)	Factor (dB)	Type
1			2390.000	46.052	13.774	-7.948	54.000	32.278	AV
2		*	2411.304	97.654	65.411	N/A	N/A	32.243	AV

Test Mode: Measure Level (dB μ V/m) = Reading Level (dB μ V) + Factor (dB)

Factor (dB) = Cable Loss (dB) + Antenna Factor (dB/m)

Site: AC2	Time: 2017/03/18 - 02:58
Limit: FCC_Part15.209_RE(3m)	Engineer: Snake Ni
Probe: BBHA9120D_1-18GHz	Polarity: Horizontal
EUT: E-reader	Power: AC 120V/60Hz
Test Mode: Transmit by 802.11b at Channel 2462MHz	

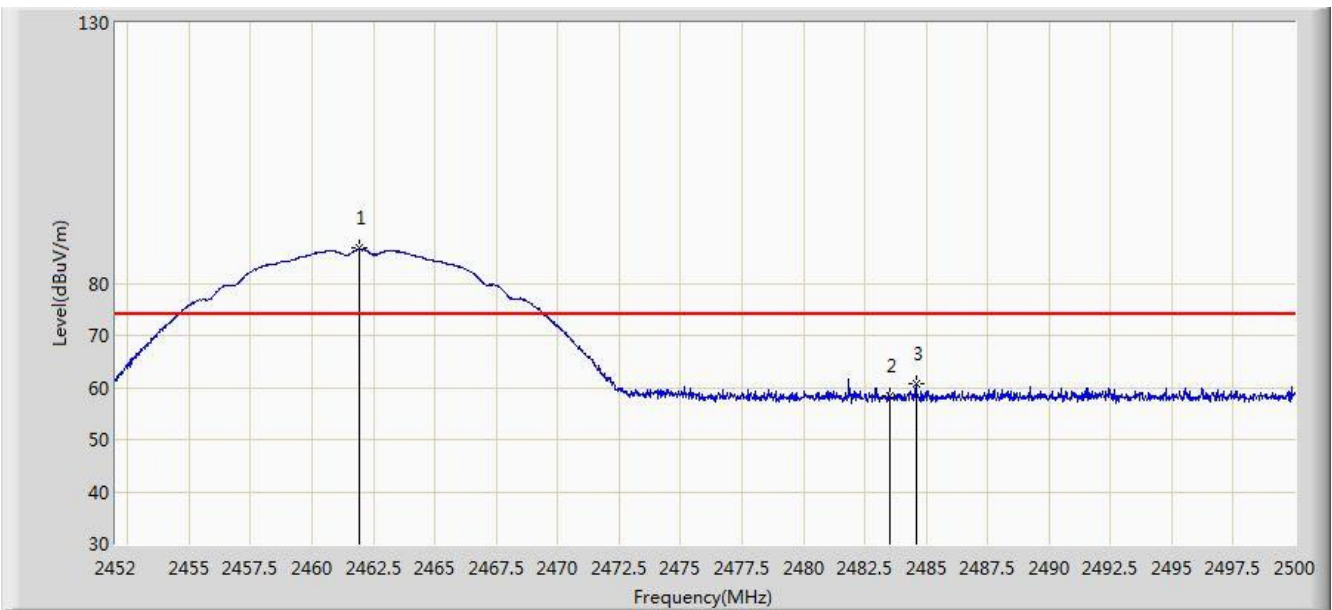

No	Flag	Mark	Frequency (MHz)	Measure Level (dBuV/m)	Reading Level (dBuV)	Over Limit (dB)	Limit (dBuV/m)	Factor (dB)	Type
1		*	2461.912	86.689	54.451	N/A	N/A	32.238	PK
2			2483.500	58.461	26.180	-15.539	74.000	32.282	PK
3			2484.592	60.639	28.354	-13.361	74.000	32.285	PK

Test Mode: Measure Level (dB μ V/m) = Reading Level (dB μ V) + Factor (dB)

Factor (dB) = Cable Loss (dB) + Antenna Factor (dB/m)

Site: AC2	Time: 2017/03/18 - 02:59
Limit: FCC_Part15.209_RE(3m)	Engineer: Snake Ni
Probe: BBHA9120D_1-18GHz	Polarity: Horizontal
EUT: E-reader	Power: AC 120V/60Hz
Test Mode: Transmit by 802.11b at Channel 2462MHz	



No	Flag	Mark	Frequency (MHz)	Measure Level (dBuV/m)	Reading Level (dBuV)	Over Limit (dB)	Limit (dBuV/m)	Factor (dB)	Type
1		*	2461.240	82.713	50.478	N/A	N/A	32.235	AV
2			2483.500	45.931	13.650	-8.069	54.000	32.282	AV

Test Mode: Measure Level (dB μ V/m) = Reading Level (dB μ V) + Factor (dB)

Factor (dB) = Cable Loss (dB) + Antenna Factor (dB/m)

Site: AC2	Time: 2017/03/18 - 03:00
Limit: FCC_Part15.209_RE(3m)	Engineer: Snake Ni
Probe: BBHA9120D_1-18GHz	Polarity: Vertical
EUT: E-reader	Power: AC 120V/60Hz
Test Mode: Transmit by 802.11b at Channel 2462MHz	

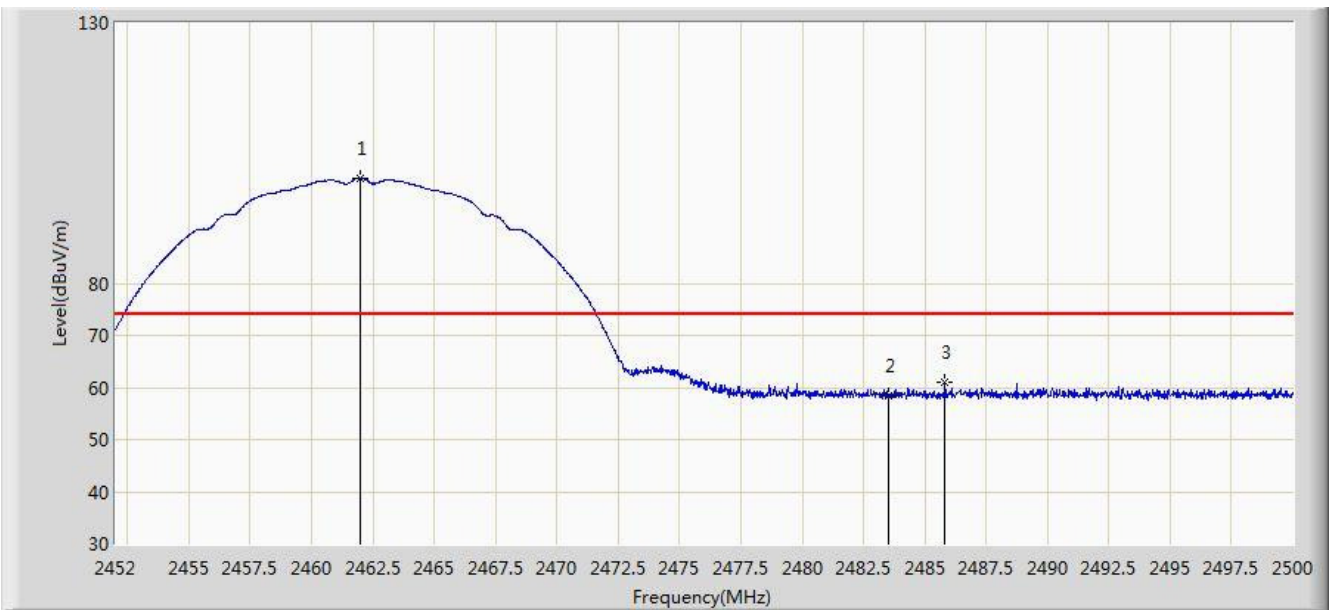

No	Flag	Mark	Frequency (MHz)	Measure Level (dBuV/m)	Reading Level (dBuV)	Over Limit (dB)	Limit (dBuV/m)	Factor (dB)	Type
1		*	2461.984	100.269	68.031	N/A	N/A	32.238	PK
2			2483.500	58.525	26.244	-15.475	74.000	32.282	PK
3			2485.816	60.983	28.694	-13.017	74.000	32.289	PK

Test Mode: Measure Level (dB μ V/m) = Reading Level (dB μ V) + Factor (dB)

Factor (dB) = Cable Loss (dB) + Antenna Factor (dB/m)

Site: AC2	Time: 2017/03/18 - 03:01
Limit: FCC_Part15.209_RE(3m)	Engineer: Snake Ni
Probe: BBHA9120D_1-18GHz	Polarity: Vertical
EUT: E-reader	Power: AC 120V/60Hz
Test Mode: Transmit by 802.11b at Channel 2462MHz	



No	Flag	Mark	Frequency (MHz)	Measure Level (dBuV/m)	Reading Level (dBuV)	Over Limit (dB)	Limit (dBuV/m)	Factor (dB)	Type
1		*	2461.312	96.397	64.162	N/A	N/A	32.235	AV
2			2483.500	46.112	13.831	-7.888	54.000	32.282	AV

Test Mode: Measure Level (dB μ V/m) = Reading Level (dB μ V) + Factor (dB)

Factor (dB) = Cable Loss (dB) + Antenna Factor (dB/m)

Site: AC2	Time: 2017/03/18 - 03:01
Limit: FCC_Part15.209_RE(3m)	Engineer: Snake Ni
Probe: BBHA9120D_1-18GHz	Polarity: Horizontal
EUT: E-reader	Power: AC 120V/60Hz
Test Mode: Transmit by 802.11g at Channel 2412MHz	

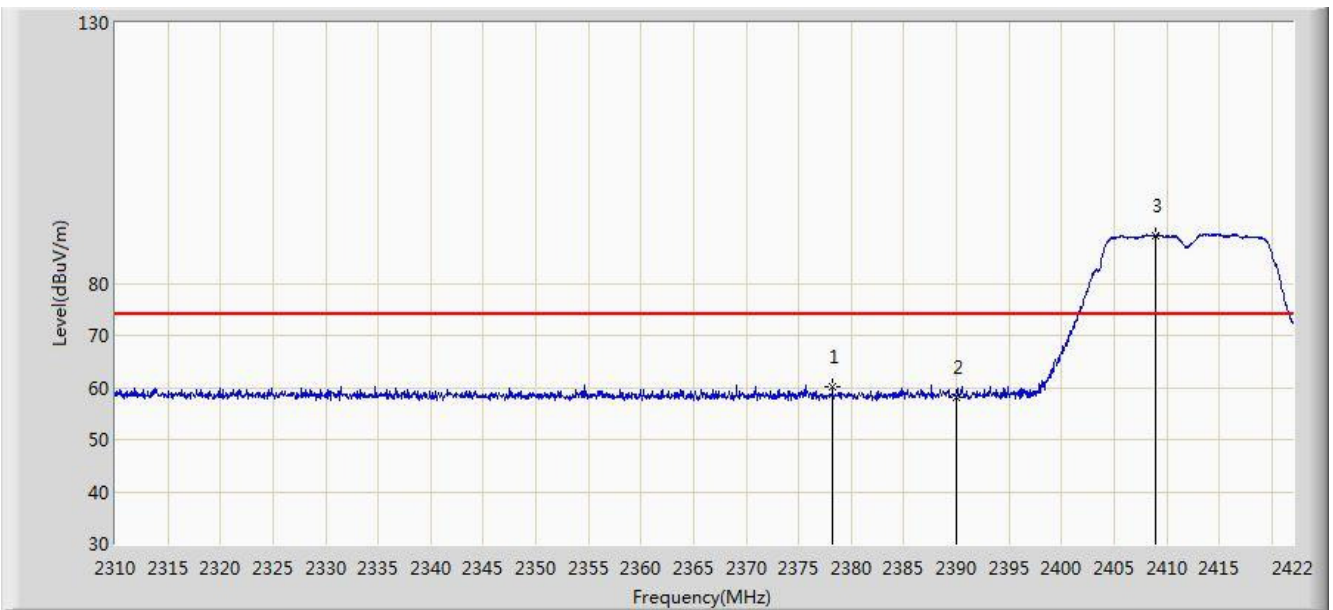

No	Flag	Mark	Frequency (MHz)	Measure Level (dBuV/m)	Reading Level (dBuV)	Over Limit (dB)	Limit (dBuV/m)	Factor (dB)	Type
1			2378.208	60.080	27.868	-13.920	74.000	32.212	PK
2			2390.000	58.113	25.835	-15.887	74.000	32.278	PK
3		*	2408.896	89.208	56.957	N/A	N/A	32.250	PK

Test Mode: Measure Level (dB μ V/m) = Reading Level (dB μ V) + Factor (dB)

Factor (dB) = Cable Loss (dB) + Antenna Factor (dB/m)

Site: AC2	Time: 2017/03/18 - 03:03
Limit: FCC_Part15.209_RE(3m)	Engineer: Snake Ni
Probe: BBHA9120D_1-18GHz	Polarity: Horizontal
EUT: E-reader	Power: AC 120V/60Hz
Test Mode: Transmit by 802.11g at Channel 2412MHz	

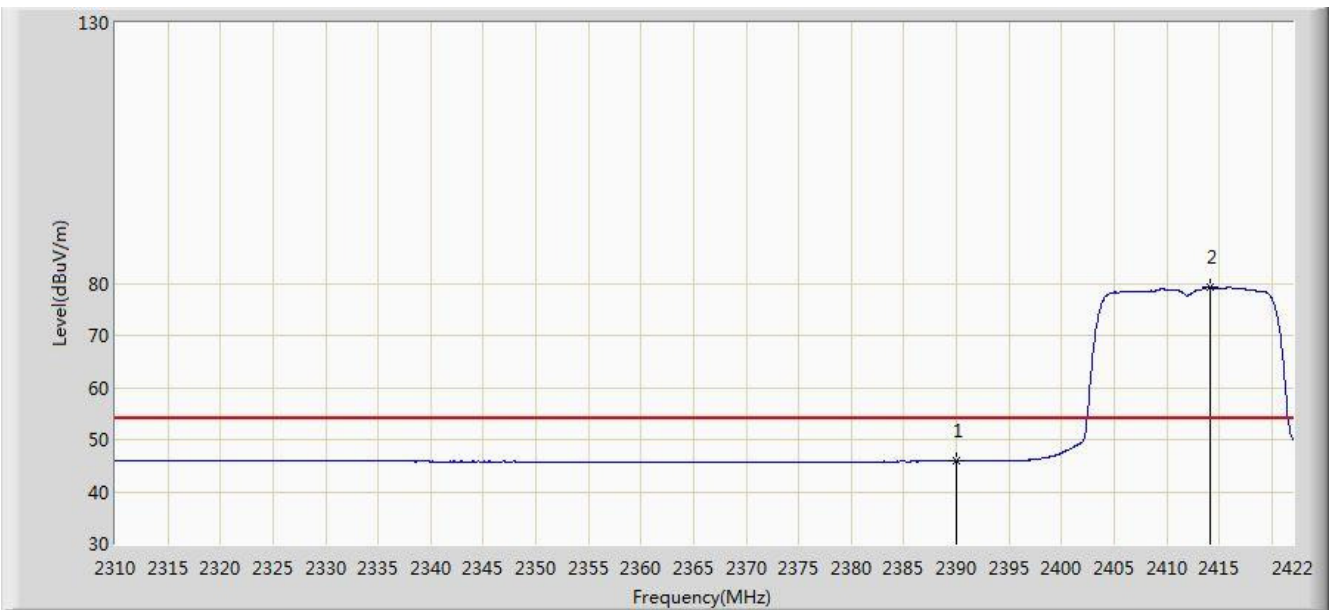

No	Flag	Mark	Frequency (MHz)	Measure Level (dBuV/m)	Reading Level (dBuV)	Over Limit (dB)	Limit (dBuV/m)	Factor (dB)	Type
1			2390.000	45.917	13.639	-8.083	54.000	32.278	AV
2		*	2414.104	79.227	46.996	N/A	N/A	32.231	AV

Test Mode: Measure Level (dB μ V/m) = Reading Level (dB μ V) + Factor (dB)

Factor (dB) = Cable Loss (dB) + Antenna Factor (dB/m)

Site: AC2	Time: 2017/03/18 - 03:03
Limit: FCC_Part15.209_RE(3m)	Engineer: Snake Ni
Probe: BBHA9120D_1-18GHz	Polarity: Vertical
EUT: E-reader	Power: AC 120V/60Hz
Test Mode: Transmit by 802.11g at Channel 2412MHz	

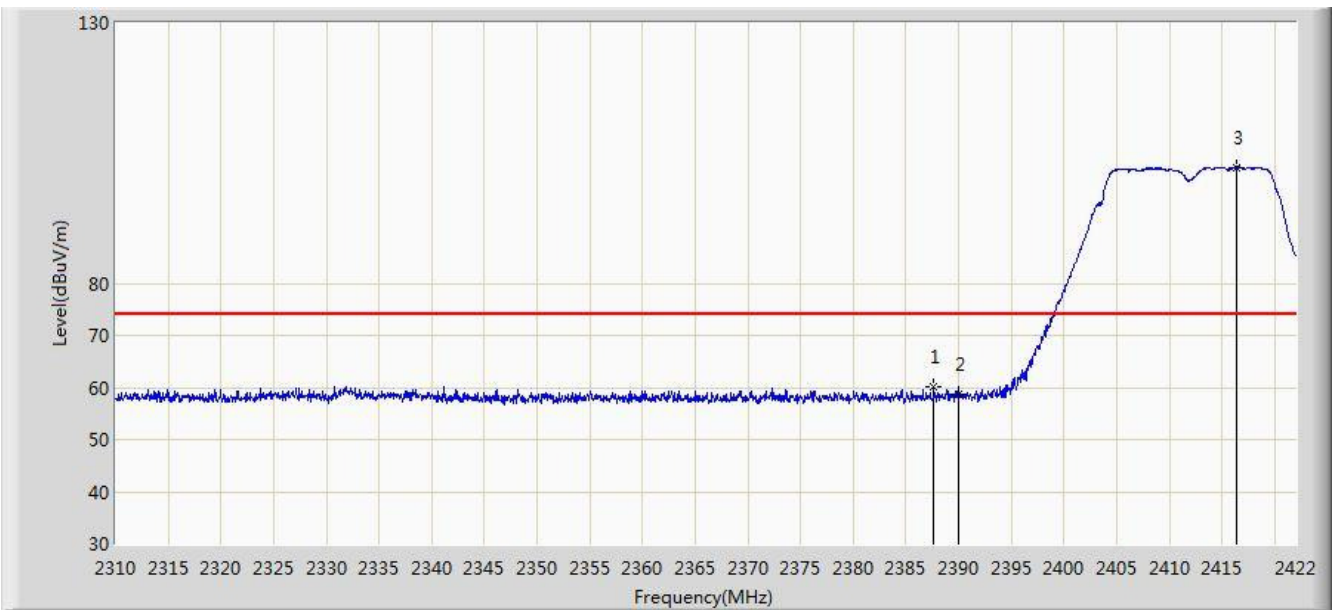

No	Flag	Mark	Frequency (MHz)	Measure Level (dBuV/m)	Reading Level (dBuV)	Over Limit (dB)	Limit (dBuV/m)	Factor (dB)	Type
1			2387.672	60.041	27.776	-13.959	74.000	32.265	PK
2			2390.000	58.658	26.380	-15.342	74.000	32.278	PK
3		*	2416.344	102.259	70.037	N/A	N/A	32.222	PK

Test Mode: Measure Level (dB μ V/m) = Reading Level (dB μ V) + Factor (dB)

Factor (dB) = Cable Loss (dB) + Antenna Factor (dB/m)

Site: AC2	Time: 2017/03/18 - 03:04
Limit: FCC_Part15.209_RE(3m)	Engineer: Snake Ni
Probe: BBHA9120D_1-18GHz	Polarity: Vertical
EUT: E-reader	Power: AC 120V/60Hz
Test Mode: Transmit by 802.11g at Channel 2412MHz	

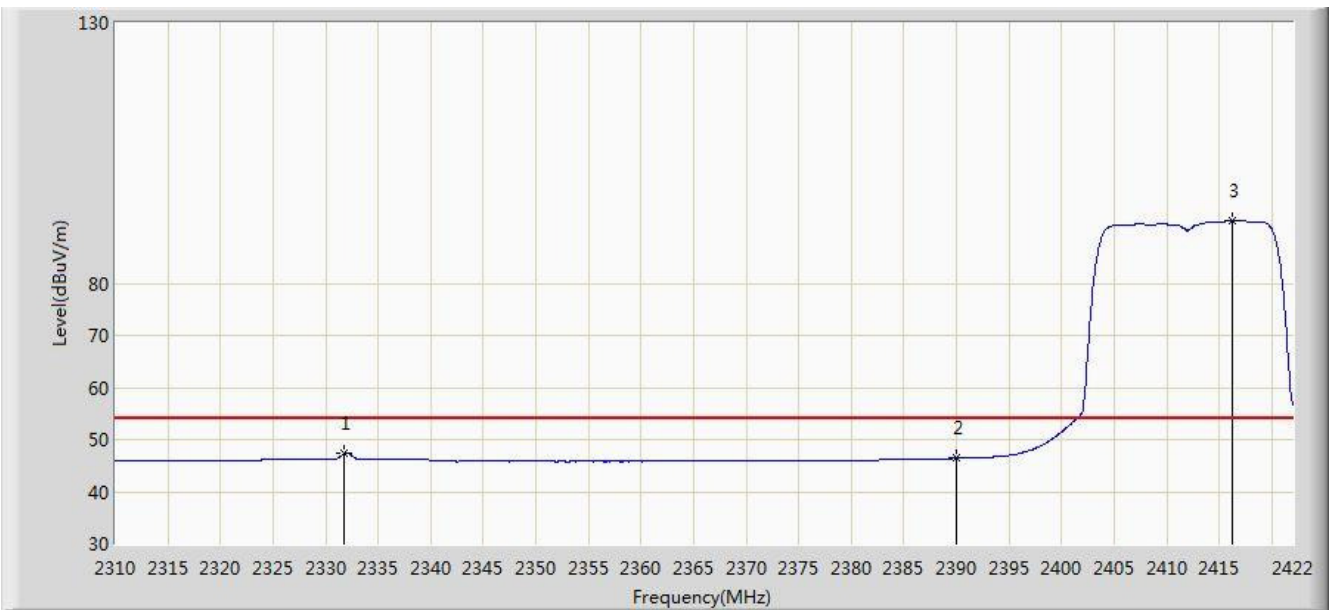

No	Flag	Mark	Frequency (MHz)	Measure Level (dBuV/m)	Reading Level (dBuV)	Over Limit (dB)	Limit (dBuV/m)	Factor (dB)	Type
1			2331.728	47.309	14.956	-6.691	54.000	32.353	AV
2			2390.000	46.404	14.126	-7.596	54.000	32.278	AV
3		*	2416.176	91.980	59.758	N/A	N/A	32.222	AV

Test Mode: Measure Level (dB μ V/m) = Reading Level (dB μ V) + Factor (dB)

Factor (dB) = Cable Loss (dB) + Antenna Factor (dB/m)

Site: AC2	Time: 2017/03/18 - 03:04
Limit: FCC_Part15.209_RE(3m)	Engineer: Snake Ni
Probe: BBHA9120D_1-18GHz	Polarity: Horizontal
EUT: E-reader	Power: AC 120V/60Hz
Test Mode: Transmit by 802.11g at Channel 2462MHz	

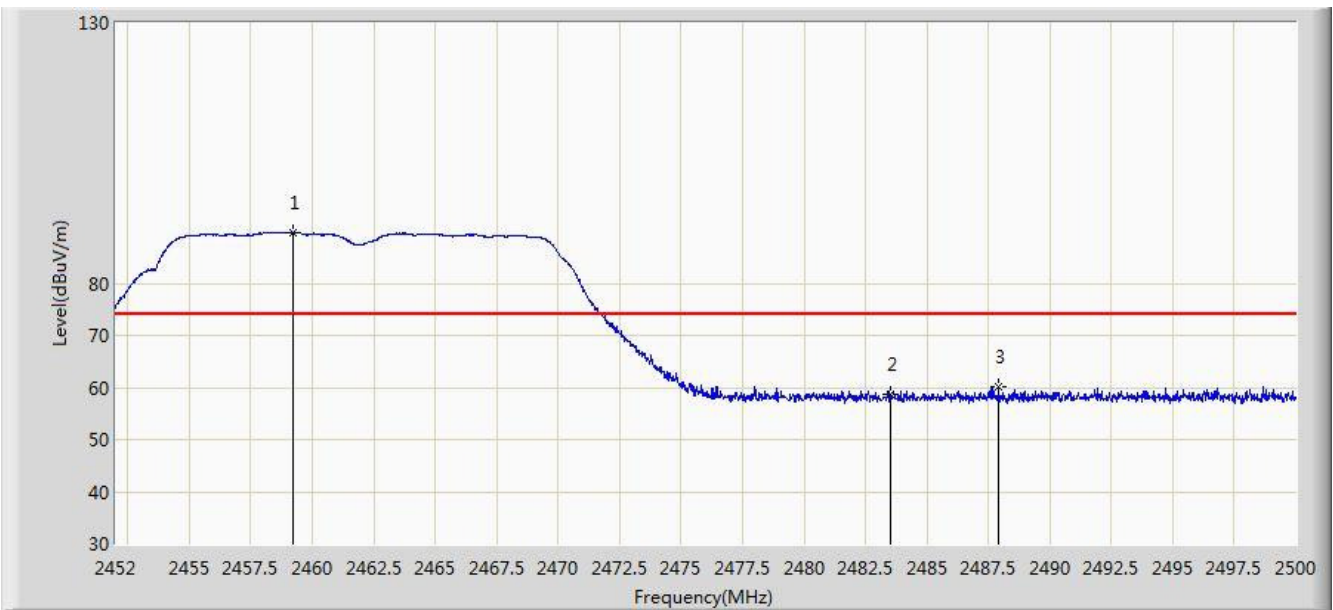

No	Flag	Mark	Frequency (MHz)	Measure Level (dBuV/m)	Reading Level (dBuV)	Over Limit (dB)	Limit (dBuV/m)	Factor (dB)	Type
1		*	2459.224	89.654	57.428	N/A	N/A	32.226	PK
2			2483.500	58.597	26.316	-15.403	74.000	32.282	PK
3			2487.904	60.046	27.750	-13.954	74.000	32.297	PK

Test Mode: Measure Level (dB μ V/m) = Reading Level (dB μ V) + Factor (dB)

Factor (dB) = Cable Loss (dB) + Antenna Factor (dB/m)

Site: AC2	Time: 2017/03/18 - 03:05
Limit: FCC_Part15.209_RE(3m)	Engineer: Snake Ni
Probe: BBHA9120D_1-18GHz	Polarity: Horizontal
EUT: E-reader	Power: AC 120V/60Hz
Test Mode: Transmit by 802.11g at Channel 2462MHz	

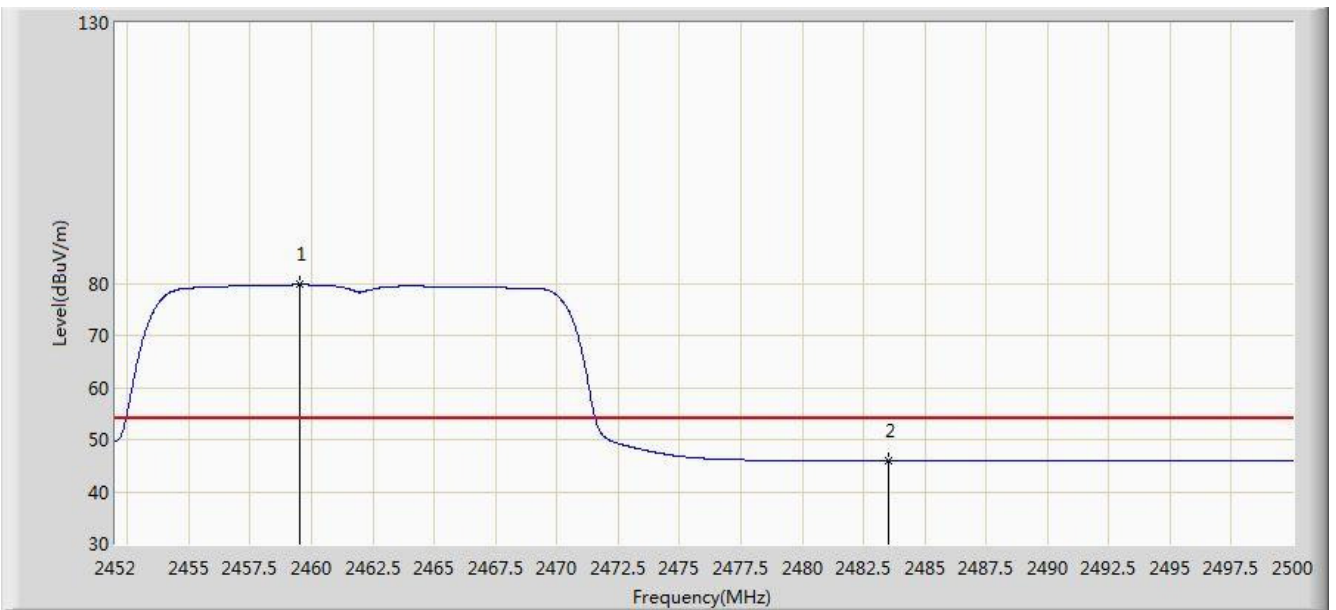

No	Flag	Mark	Frequency (MHz)	Measure Level (dBuV/m)	Reading Level (dBuV)	Over Limit (dB)	Limit (dBuV/m)	Factor (dB)	Type
1		*	2459.512	79.805	47.577	N/A	N/A	32.227	AV
2			2483.500	45.984	13.703	-8.016	54.000	32.282	AV

Test Mode: Measure Level (dB μ V/m) = Reading Level (dB μ V) + Factor (dB)

Factor (dB) = Cable Loss (dB) + Antenna Factor (dB/m)

Site: AC2	Time: 2017/03/18 - 03:06
Limit: FCC_Part15.209_RE(3m)	Engineer: Snake Ni
Probe: BBHA9120D_1-18GHz	Polarity: Vertical
EUT: E-reader	Power: AC 120V/60Hz
Test Mode: Transmit by 802.11g at Channel 2462MHz	

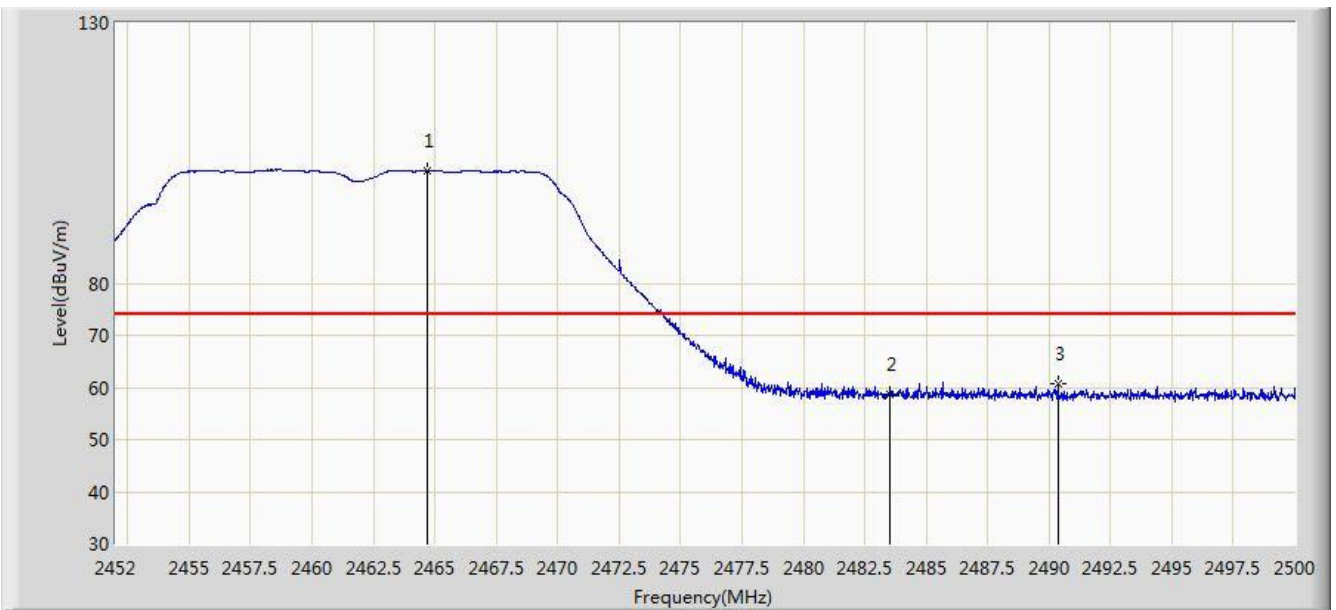

No	Flag	Mark	Frequency (MHz)	Measure Level (dBuV/m)	Reading Level (dBuV)	Over Limit (dB)	Limit (dBuV/m)	Factor (dB)	Type
1		*	2464.672	101.607	69.366	N/A	N/A	32.242	PK
2			2483.500	58.640	26.359	-15.360	74.000	32.282	PK
3			2490.352	60.769	28.464	-13.231	74.000	32.305	PK

Test Mode: Measure Level (dB μ V/m) = Reading Level (dB μ V) + Factor (dB)

Factor (dB) = Cable Loss (dB) + Antenna Factor (dB/m)

Site: AC2	Time: 2017/03/18 - 03:06
Limit: FCC_Part15.209_RE(3m)	Engineer: Snake Ni
Probe: BBHA9120D_1-18GHz	Polarity: Vertical
EUT: E-reader	Power: AC 120V/60Hz
Test Mode: Transmit by 802.11g at Channel 2462MHz	

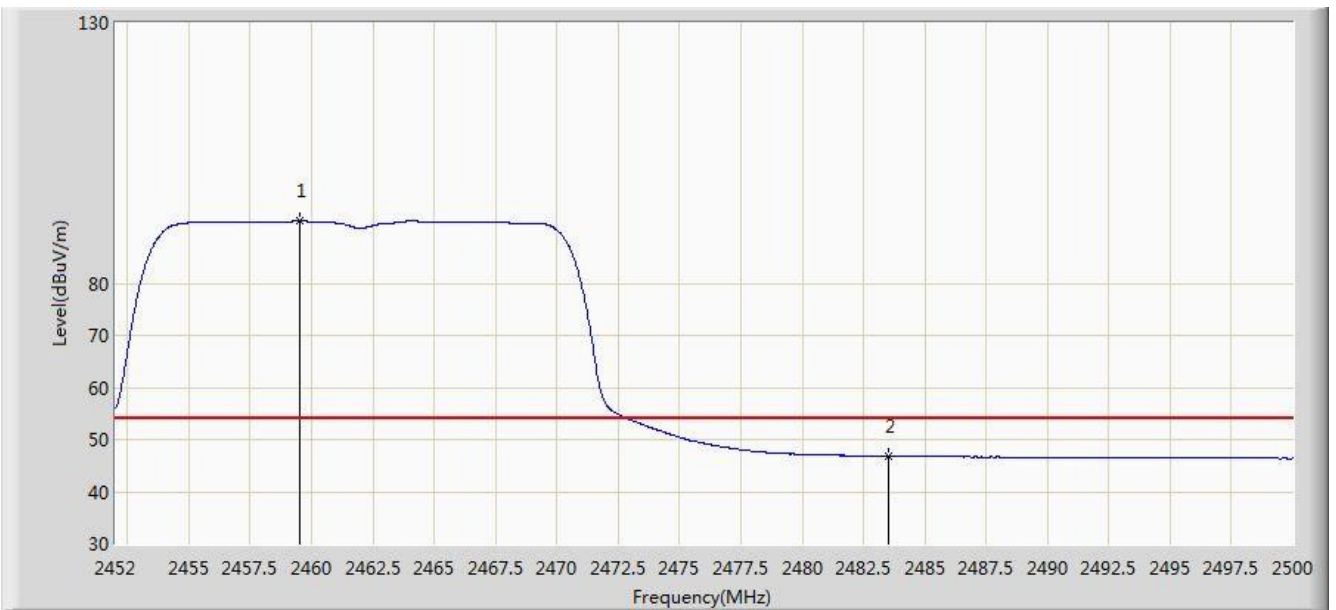

No	Flag	Mark	Frequency (MHz)	Measure Level (dBuV/m)	Reading Level (dBuV)	Over Limit (dB)	Limit (dBuV/m)	Factor (dB)	Type
1		*	2459.512	91.961	59.733	N/A	N/A	32.227	AV
2			2483.500	46.824	14.543	-7.176	54.000	32.282	AV

Test Mode: Measure Level (dB μ V/m) = Reading Level (dB μ V) + Factor (dB)

Factor (dB) = Cable Loss (dB) + Antenna Factor (dB/m)

Site: AC2	Time: 2017/03/18 - 03:07
Limit: FCC_Part15.209_RE(3m)	Engineer: Snake Ni
Probe: BBHA9120D_1-18GHz	Polarity: Horizontal
EUT: E-reader	Power: AC 120V/60Hz
Test Mode: Transmit by 802.11n-HT20 at Channel 2412MHz	

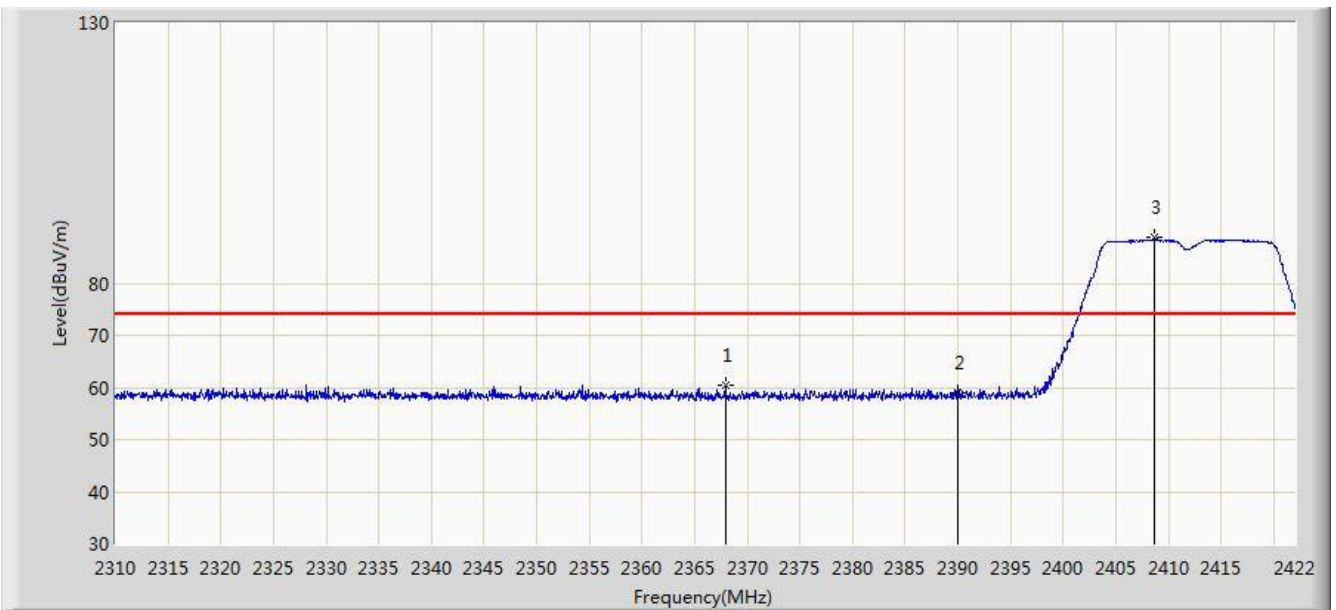

No	Flag	Mark	Frequency (MHz)	Measure Level (dBuV/m)	Reading Level (dBuV)	Over Limit (dB)	Limit (dBuV/m)	Factor (dB)	Type
1			2367.904	60.332	28.103	-13.668	74.000	32.229	PK
2			2390.000	59.041	26.763	-14.959	74.000	32.278	PK
3		*	2408.728	88.711	56.460	N/A	N/A	32.252	PK

Test Mode: Measure Level (dB μ V/m) = Reading Level (dB μ V) + Factor (dB)

Factor (dB) = Cable Loss (dB) + Antenna Factor (dB/m)

Site: AC2	Time: 2017/03/18 - 03:08
Limit: FCC_Part15.209_RE(3m)	Engineer: Snake Ni
Probe: BBHA9120D_1-18GHz	Polarity: Horizontal
EUT: E-reader	Power: AC 120V/60Hz
Test Mode: Transmit by 802.11n-HT20 at Channel 2412MHz	

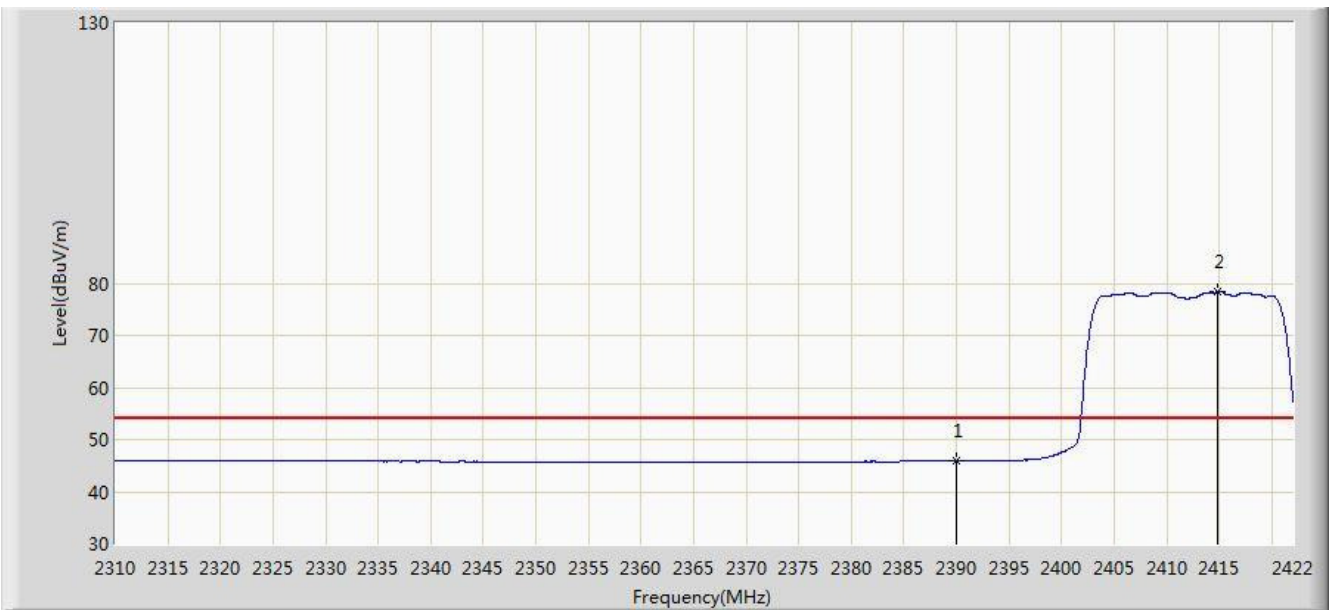

No	Flag	Mark	Frequency (MHz)	Measure Level (dBuV/m)	Reading Level (dBuV)	Over Limit (dB)	Limit (dBuV/m)	Factor (dB)	Type
1			2390.000	45.904	13.626	-8.096	54.000	32.278	AV
2		*	2414.776	78.298	46.070	N/A	N/A	32.228	AV

Test Mode: Measure Level (dB μ V/m) = Reading Level (dB μ V) + Factor (dB)

Factor (dB) = Cable Loss (dB) + Antenna Factor (dB/m)

Site: AC2	Time: 2017/03/18 - 03:08
Limit: FCC_Part15.209_RE(3m)	Engineer: Snake Ni
Probe: BBHA9120D_1-18GHz	Polarity: Vertical
EUT: E-reader	Power: AC 120V/60Hz
Test Mode: Transmit by 802.11n-HT20 at Channel 2412MHz	

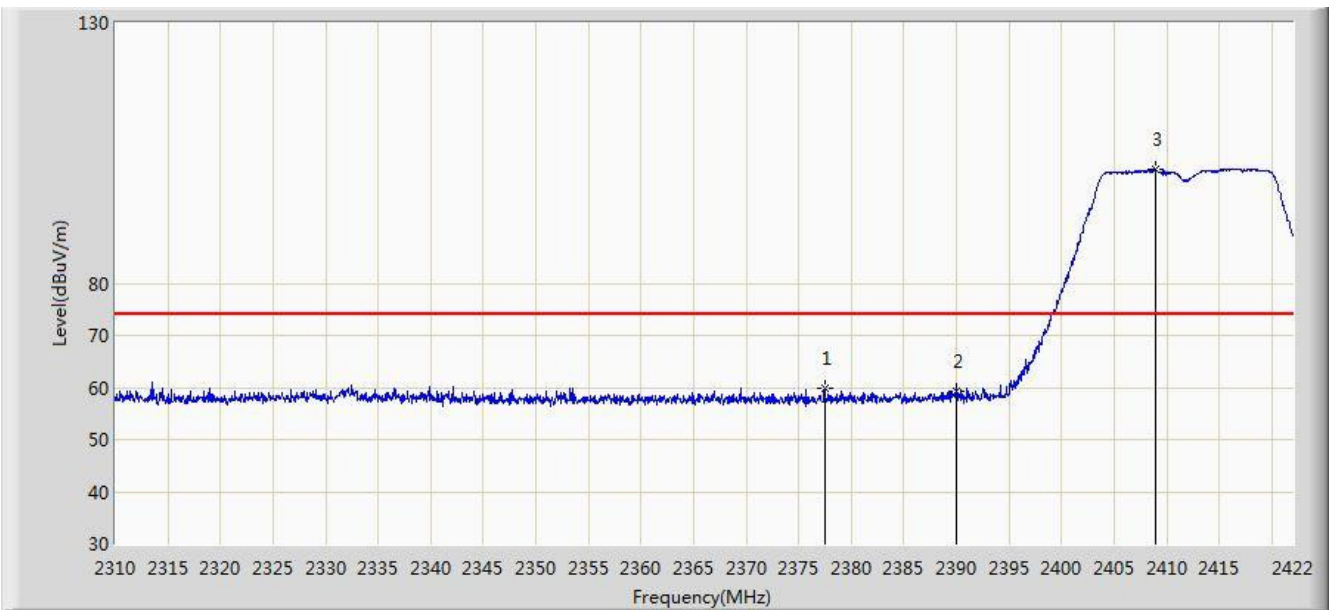

No	Flag	Mark	Frequency (MHz)	Measure Level (dBuV/m)	Reading Level (dBuV)	Over Limit (dB)	Limit (dBuV/m)	Factor (dB)	Type
1			2377.480	59.951	27.743	-14.049	74.000	32.208	PK
2			2390.000	59.350	27.072	-14.650	74.000	32.278	PK
3		*	2408.952	101.993	69.742	N/A	N/A	32.250	PK

Test Mode: Measure Level (dB μ V/m) = Reading Level (dB μ V) + Factor (dB)

Factor (dB) = Cable Loss (dB) + Antenna Factor (dB/m)

Site: AC2	Time: 2017/03/18 - 03:09
Limit: FCC_Part15.209_RE(3m)	Engineer: Snake Ni
Probe: BBHA9120D_1-18GHz	Polarity: Vertical
EUT: E-reader	Power: AC 120V/60Hz
Test Mode: Transmit by 802.11n-HT20 at Channel 2412MHz	

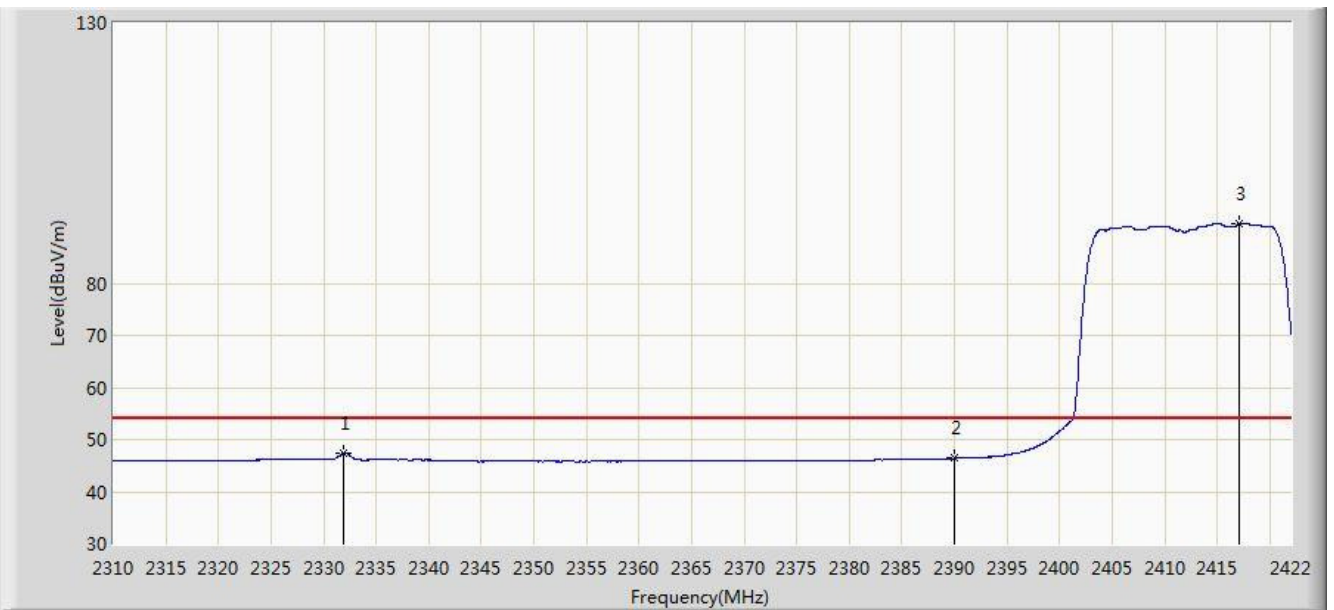

No	Flag	Mark	Frequency (MHz)	Measure Level (dBuV/m)	Reading Level (dBuV)	Over Limit (dB)	Limit (dBuV/m)	Factor (dB)	Type
1			2331.896	47.424	15.072	-6.576	54.000	32.352	AV
2			2390.000	46.381	14.103	-7.619	54.000	32.278	AV
3		*	2417.072	91.412	59.193	N/A	N/A	32.219	AV

Test Mode: Measure Level (dB μ V/m) = Reading Level (dB μ V) + Factor (dB)

Factor (dB) = Cable Loss (dB) + Antenna Factor (dB/m)

Site: AC2	Time: 2017/03/18 - 03:10
Limit: FCC_Part15.209_RE(3m)	Engineer: Snake Ni
Probe: BBHA9120D_1-18GHz	Polarity: Horizontal
EUT: E-reader	Power: AC 120V/60Hz
Test Mode: Transmit by 802.11n-HT20 at Channel 2462MHz	

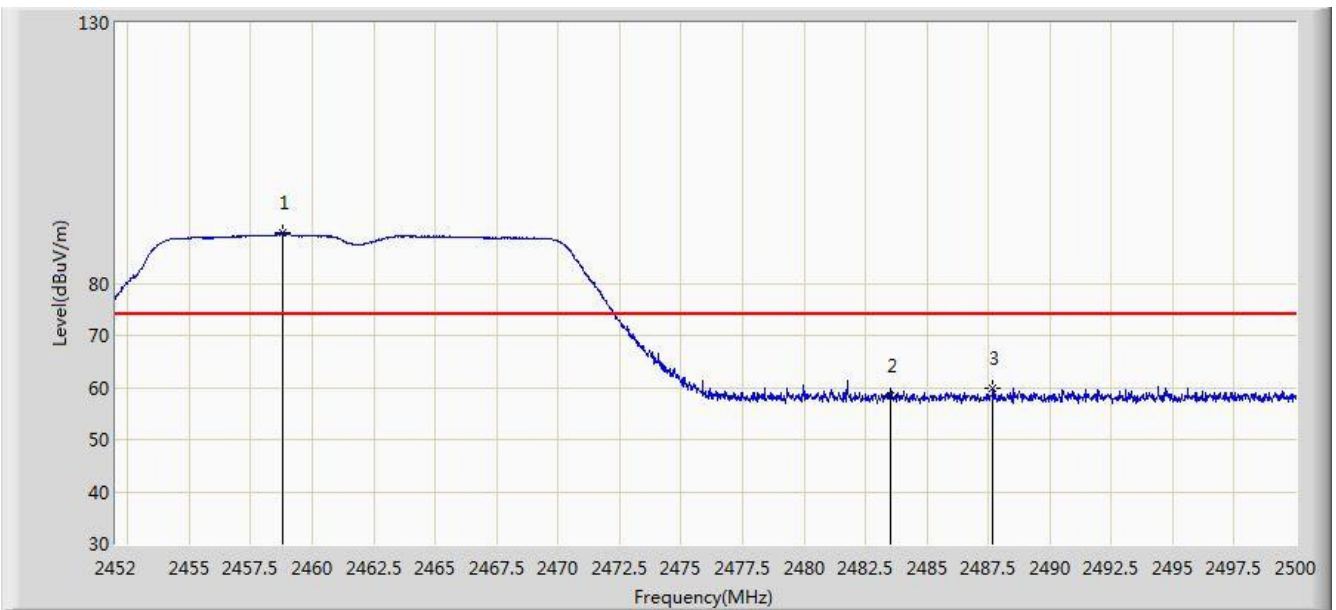

No	Flag	Mark	Frequency (MHz)	Measure Level (dBuV/m)	Reading Level (dBuV)	Over Limit (dB)	Limit (dBuV/m)	Factor (dB)	Type
1		*	2458.792	89.820	57.596	N/A	N/A	32.224	PK
2			2483.500	58.424	26.143	-15.576	74.000	32.282	PK
3			2487.688	59.896	27.600	-14.104	74.000	32.295	PK

Test Mode: Measure Level (dB μ V/m) = Reading Level (dB μ V) + Factor (dB)

Factor (dB) = Cable Loss (dB) + Antenna Factor (dB/m)

Site: AC2	Time: 2017/03/18 - 03:10
Limit: FCC_Part15.209_RE(3m)	Engineer: Snake Ni
Probe: BBHA9120D_1-18GHz	Polarity: Horizontal
EUT: E-reader	Power: AC 120V/60Hz
Test Mode: Transmit by 802.11n-HT20 at Channel 2462MHz	

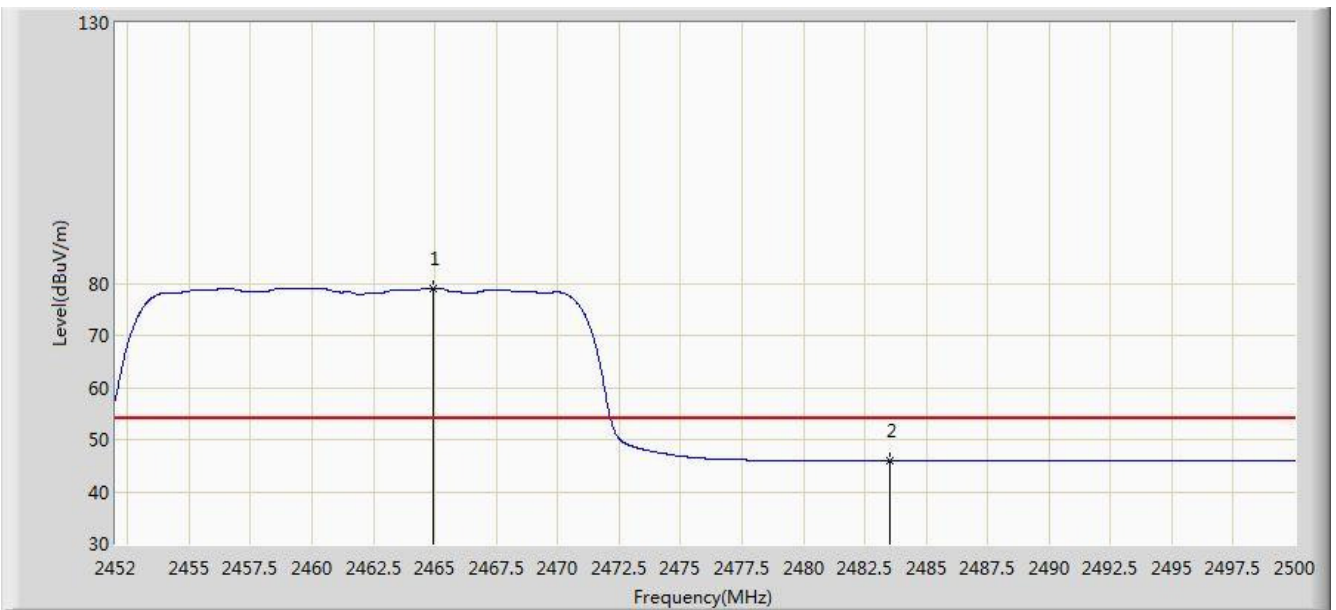

No	Flag	Mark	Frequency (MHz)	Measure Level (dBuV/m)	Reading Level (dBuV)	Over Limit (dB)	Limit (dBuV/m)	Factor (dB)	Type
1		*	2464.960	79.041	46.799	N/A	N/A	32.242	AV
2			2483.500	45.980	13.699	-8.020	54.000	32.282	AV

Test Mode: Measure Level (dB μ V/m) = Reading Level (dB μ V) + Factor (dB)

Factor (dB) = Cable Loss (dB) + Antenna Factor (dB/m)

Site: AC2	Time: 2017/03/18 - 03:11
Limit: FCC_Part15.209_RE(3m)	Engineer: Snake Ni
Probe: BBHA9120D_1-18GHz	Polarity: Vertical
EUT: E-reader	Power: AC 120V/60Hz
Test Mode: Transmit by 802.11n-HT20 at Channel 2462MHz	

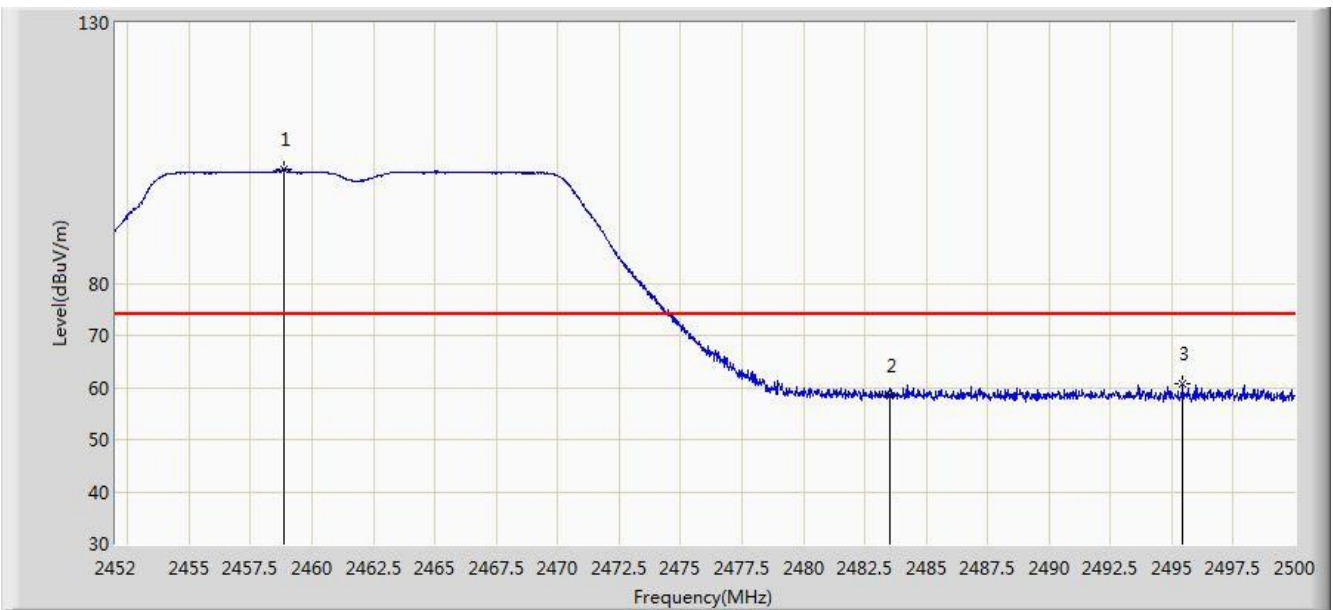

No	Flag	Mark	Frequency (MHz)	Measure Level (dBuV/m)	Reading Level (dBuV)	Over Limit (dB)	Limit (dBuV/m)	Factor (dB)	Type
1		*	2458.840	101.896	69.671	N/A	N/A	32.225	PK
2			2483.500	58.513	26.232	-15.487	74.000	32.282	PK
3			2495.440	60.715	28.393	-13.285	74.000	32.322	PK

Test Mode: Measure Level (dB μ V/m) = Reading Level (dB μ V) + Factor (dB)

Factor (dB) = Cable Loss (dB) + Antenna Factor (dB/m)

Site: AC2	Time: 2017/03/18 - 03:11
Limit: FCC_Part15.209_RE(3m)	Engineer: Snake Ni
Probe: BBHA9120D_1-18GHz	Polarity: Vertical
EUT: E-reader	Power: AC 120V/60Hz
Test Mode: Transmit by 802.11n-HT20 at Channel 2462MHz	

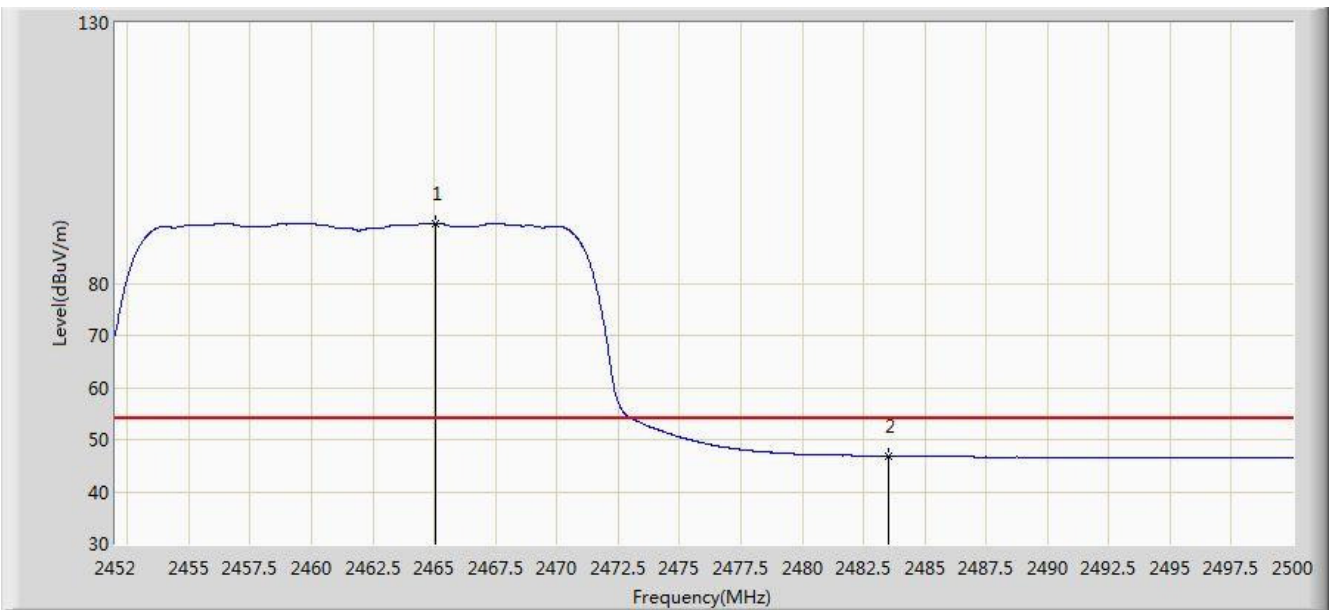

No	Flag	Mark	Frequency (MHz)	Measure Level (dBuV/m)	Reading Level (dBuV)	Over Limit (dB)	Limit (dBuV/m)	Factor (dB)	Type
1		*	2465.032	91.575	59.333	N/A	N/A	32.242	AV
2			2483.500	46.826	14.545	-7.174	54.000	32.282	AV

Test Mode: Measure Level (dB μ V/m) = Reading Level (dB μ V) + Factor (dB)

Factor (dB) = Cable Loss (dB) + Antenna Factor (dB/m)

Site: AC2	Time: 2017/03/18 - 03:12
Limit: FCC_Part15.209_RE(3m)	Engineer: Snake Ni
Probe: BBHA9120D_1-18GHz	Polarity: Horizontal
EUT: E-reader	Power: AC 120V/60Hz
Test Mode: Transmit by 802.11n-HT40 at Channel 2422MHz	

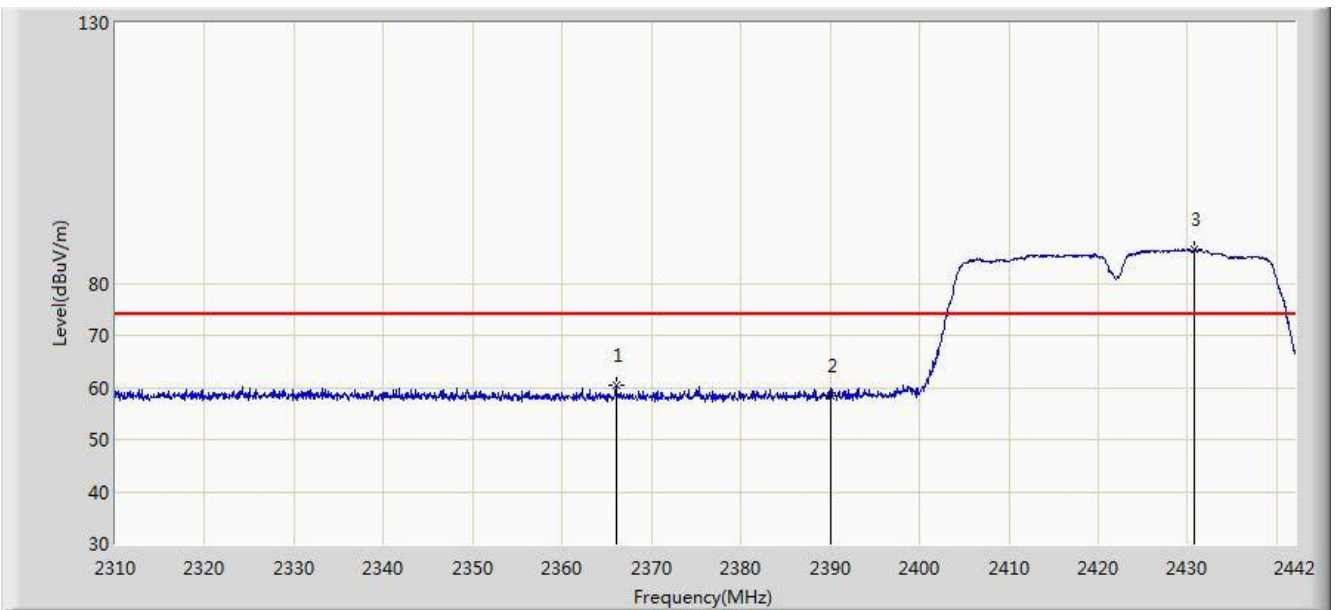

No	Flag	Mark	Frequency (MHz)	Measure Level (dBuV/m)	Reading Level (dBuV)	Over Limit (dB)	Limit (dBuV/m)	Factor (dB)	Type
1			2366.034	60.307	28.073	-13.693	74.000	32.234	PK
2			2390.000	58.457	26.179	-15.543	74.000	32.278	PK
3		*	2430.714	86.381	54.208	N/A	N/A	32.172	PK

Test Mode: Measure Level (dB μ V/m) = Reading Level (dB μ V) + Factor (dB)

Factor (dB) = Cable Loss (dB) + Antenna Factor (dB/m)

Site: AC2	Time: 2017/03/18 - 03:13
Limit: FCC_Part15.209_RE(3m)	Engineer: Snake Ni
Probe: BBHA9120D_1-18GHz	Polarity: Horizontal
EUT: E-reader	Power: AC 120V/60Hz
Test Mode: Transmit by 802.11n-HT40 at Channel 2422MHz	

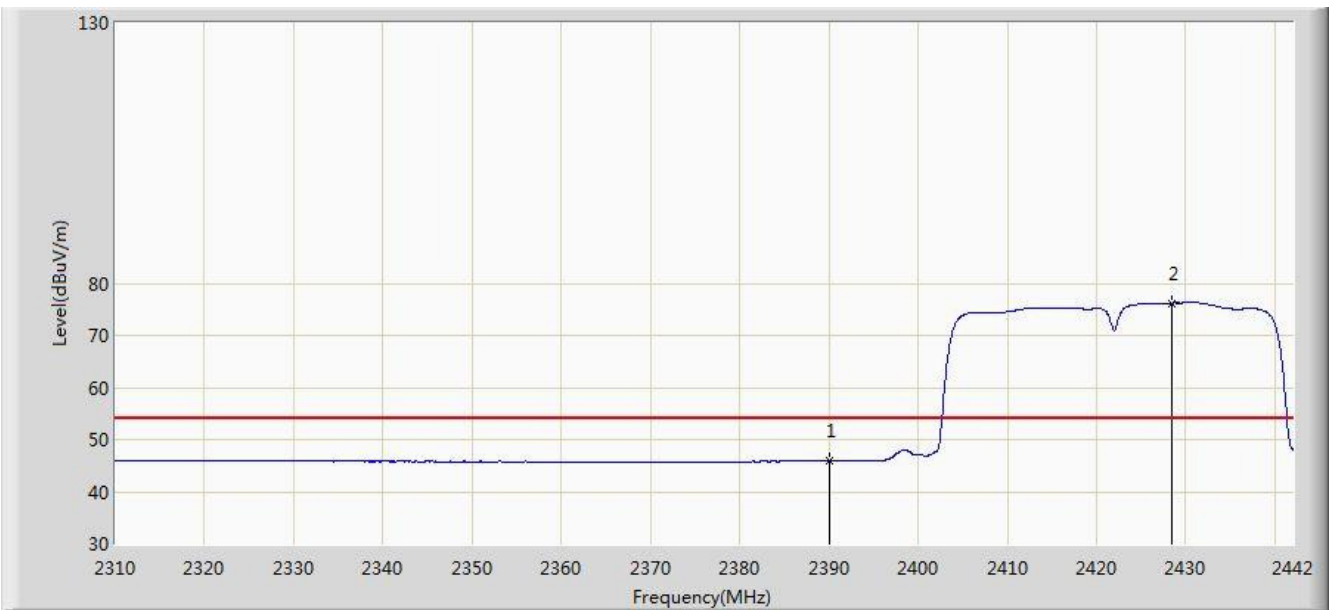

No	Flag	Mark	Frequency (MHz)	Measure Level (dBuV/m)	Reading Level (dBuV)	Over Limit (dB)	Limit (dBuV/m)	Factor (dB)	Type
1			2390.000	45.920	13.642	-8.080	54.000	32.278	AV
2		*	2428.404	76.195	44.022	N/A	N/A	32.173	AV

Test Mode: Measure Level (dB μ V/m) = Reading Level (dB μ V) + Factor (dB)

Factor (dB) = Cable Loss (dB) + Antenna Factor (dB/m)

Site: AC2	Time: 2017/03/18 - 03:13
Limit: FCC_Part15.209_RE(3m)	Engineer: Snake Ni
Probe: BBHA9120D_1-18GHz	Polarity: Vertical
EUT: E-reader	Power: AC 120V/60Hz
Test Mode: Transmit by 802.11n-HT40 at Channel 2422MHz	

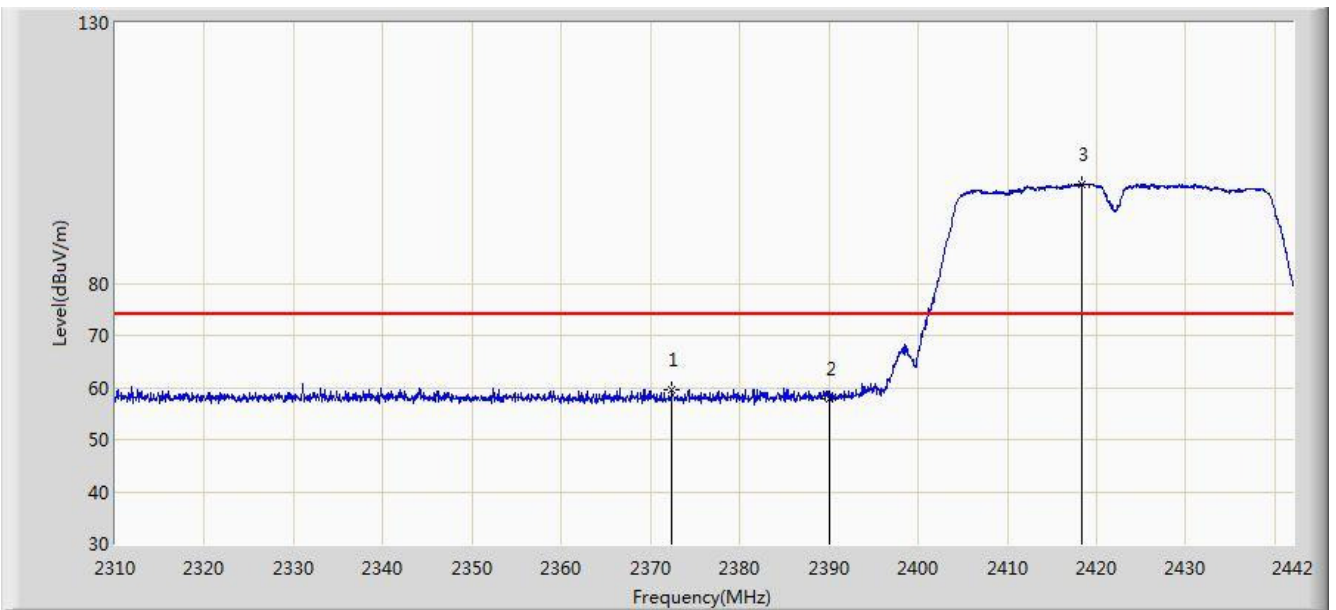

No	Flag	Mark	Frequency (MHz)	Measure Level (dBuV/m)	Reading Level (dBuV)	Over Limit (dB)	Limit (dBuV/m)	Factor (dB)	Type
1			2372.436	59.676	27.458	-14.324	74.000	32.217	PK
2			2390.000	57.930	25.652	-16.070	74.000	32.278	PK
3		*	2418.372	98.974	66.761	N/A	N/A	32.213	PK

Test Mode: Measure Level (dB μ V/m) = Reading Level (dB μ V) + Factor (dB)

Factor (dB) = Cable Loss (dB) + Antenna Factor (dB/m)

Site: AC2	Time: 2017/03/18 - 03:14
Limit: FCC_Part15.209_RE(3m)	Engineer: Snake Ni
Probe: BBHA9120D_1-18GHz	Polarity: Vertical
EUT: E-reader	Power: AC 120V/60Hz
Test Mode: Transmit by 802.11n-HT40 at Channel 2422MHz	



No	Flag	Mark	Frequency (MHz)	Measure Level (dBuV/m)	Reading Level (dBuV)	Over Limit (dB)	Limit (dBuV/m)	Factor (dB)	Type
1			2390.000	46.377	14.099	-7.623	54.000	32.278	AV
2		*	2417.514	88.544	56.327	N/A	N/A	32.217	AV

Test Mode: Measure Level (dB μ V/m) = Reading Level (dB μ V) + Factor (dB)

Factor (dB) = Cable Loss (dB) + Antenna Factor (dB/m)

Site: AC2	Time: 2017/03/18 - 03:15
Limit: FCC_Part15.209_RE(3m)	Engineer: Snake Ni
Probe: BBHA9120D_1-18GHz	Polarity: Horizontal
EUT: E-reader	Power: AC 120V/60Hz
Test Mode: Transmit by 802.11n-HT40 at Channel 2452MHz	

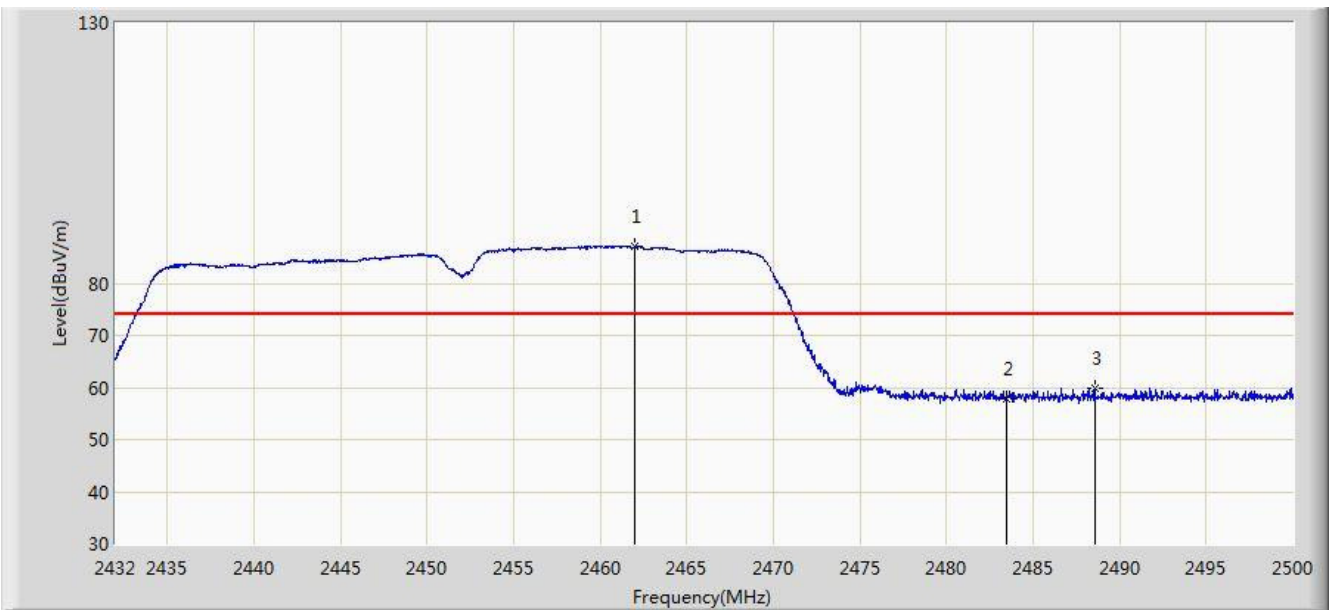

No	Flag	Mark	Frequency (MHz)	Measure Level (dBuV/m)	Reading Level (dBuV)	Over Limit (dB)	Limit (dBuV/m)	Factor (dB)	Type
1		*	2461.988	86.989	54.751	N/A	N/A	32.238	PK
2			2483.500	57.819	25.538	-16.181	74.000	32.282	PK
3			2488.576	59.985	27.686	-14.015	74.000	32.299	PK

Test Mode: Measure Level (dB μ V/m) = Reading Level (dB μ V) + Factor (dB)

Factor (dB) = Cable Loss (dB) + Antenna Factor (dB/m)

Site: AC2	Time: 2017/03/18 - 03:15
Limit: FCC_Part15.209_RE(3m)	Engineer: Snake Ni
Probe: BBHA9120D_1-18GHz	Polarity: Horizontal
EUT: E-reader	Power: AC 120V/60Hz
Test Mode: Transmit by 802.11n-HT40 at Channel 2452MHz	

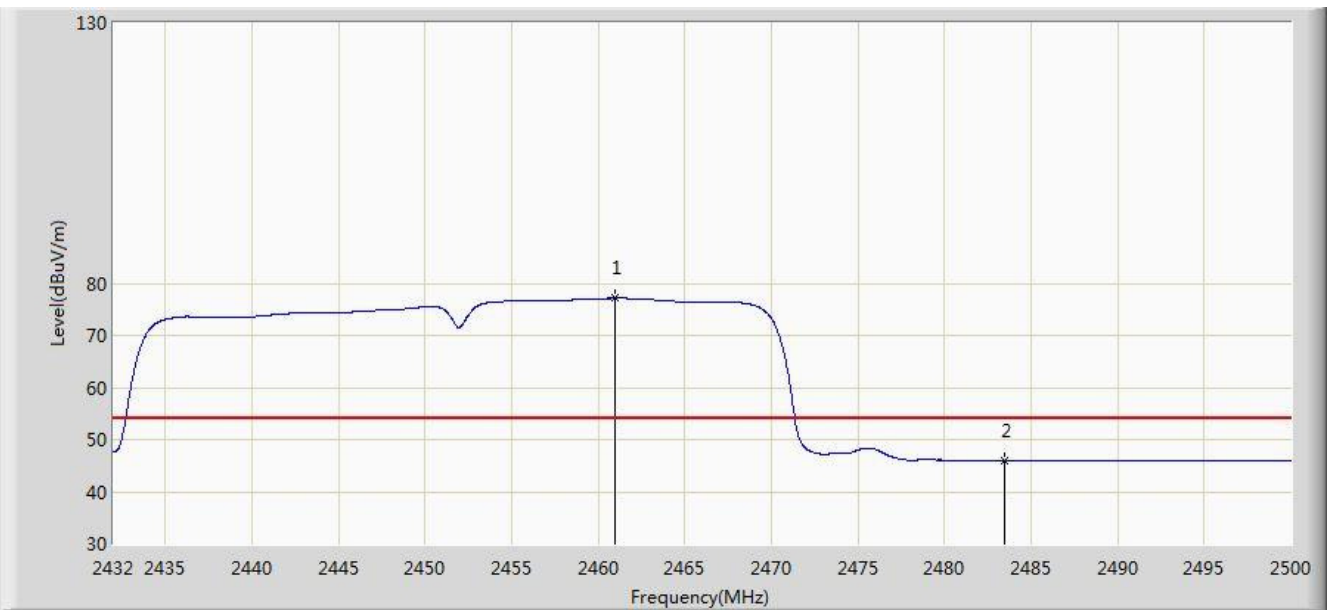

No	Flag	Mark	Frequency (MHz)	Measure Level (dBuV/m)	Reading Level (dBuV)	Over Limit (dB)	Limit (dBuV/m)	Factor (dB)	Type
1		*	2460.934	77.139	44.905	N/A	N/A	32.233	AV
2			2483.500	46.017	13.736	-7.983	54.000	32.282	AV

Test Mode: Measure Level (dBμV/m) = Reading Level (dBμV) + Factor (dB)

Factor (dB) = Cable Loss (dB) + Antenna Factor (dB/m)

Site: AC2	Time: 2017/03/18 - 03:16
Limit: FCC_Part15.209_RE(3m)	Engineer: Snake Ni
Probe: BBHA9120D_1-18GHz	Polarity: Vertical
EUT: E-reader	Power: AC 120V/60Hz
Test Mode: Transmit by 802.11n-HT40 at Channel 2452MHz	

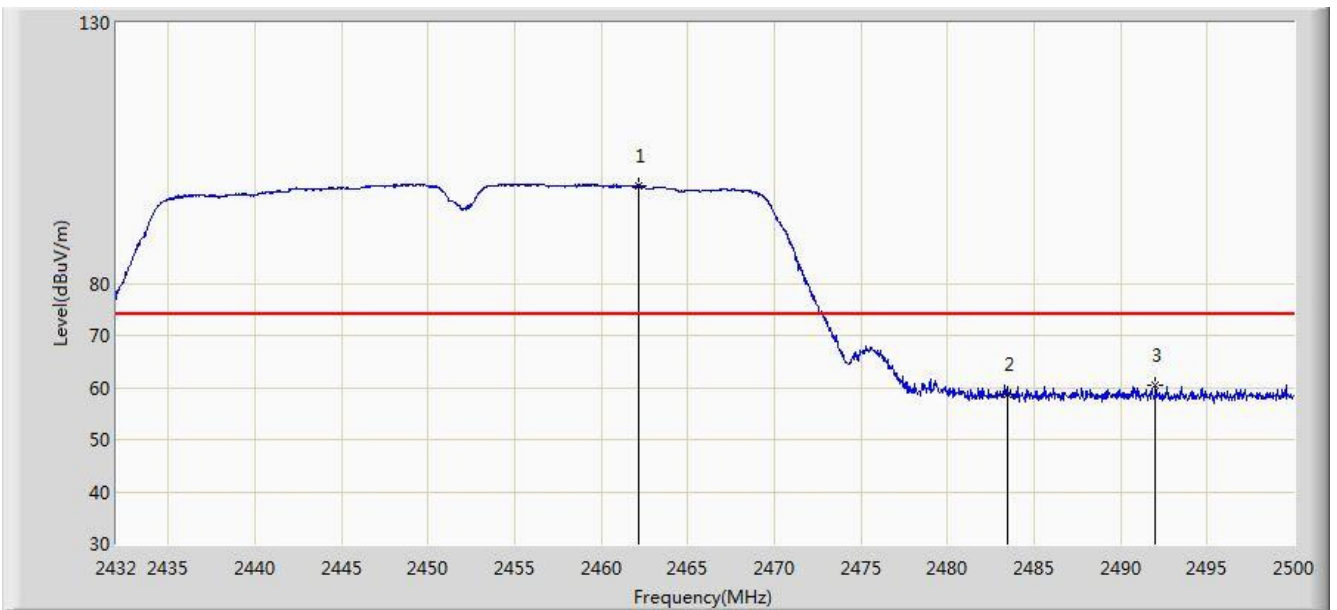

No	Flag	Mark	Frequency (MHz)	Measure Level (dBuV/m)	Reading Level (dBuV)	Over Limit (dB)	Limit (dBuV/m)	Factor (dB)	Type
1		*	2462.158	98.800	66.562	N/A	N/A	32.239	PK
2			2483.500	58.773	26.492	-15.227	74.000	32.282	PK
3			2492.010	60.337	28.026	-13.663	74.000	32.311	PK

Test Mode: Measure Level (dB μ V/m) = Reading Level (dB μ V) + Factor (dB)

Factor (dB) = Cable Loss (dB) + Antenna Factor (dB/m)

Site: AC2	Time: 2017/03/18 - 03:16
Limit: FCC_Part15.209_RE(3m)	Engineer: Snake Ni
Probe: BBHA9120D_1-18GHz	Polarity: Vertical
EUT: E-reader	Power: AC 120V/60Hz
Test Mode: Transmit by 802.11n-HT40 at Channel 2452MHz	

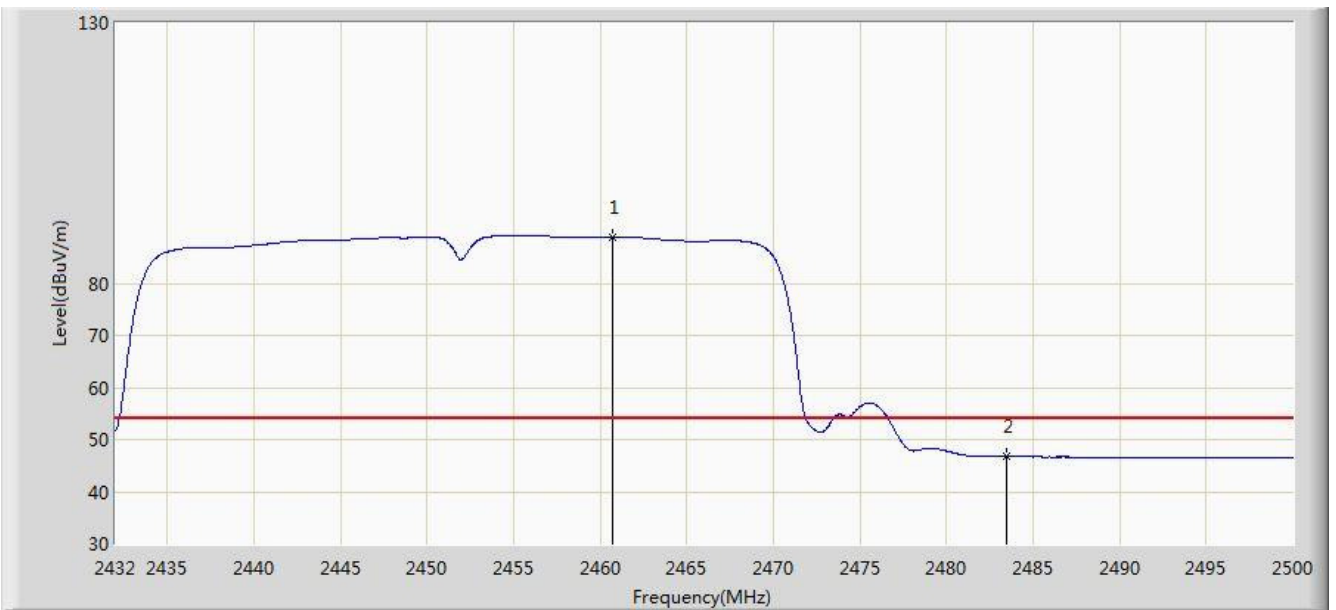

No	Flag	Mark	Frequency (MHz)	Measure Level (dBuV/m)	Reading Level (dBuV)	Over Limit (dB)	Limit (dBuV/m)	Factor (dB)	Type
1		*	2460.730	88.909	56.676	N/A	N/A	32.233	AV
2			2483.500	46.783	14.502	-7.217	54.000	32.282	AV

Test Mode: Measure Level (dB μ V/m) = Reading Level (dB μ V) + Factor (dB)

Factor (dB) = Cable Loss (dB) + Antenna Factor (dB/m)

7.8. AC Conducted Emissions Measurement

7.8.1. Test Limit

FCC Part 15 Subpart C Paragraph 15.207 Limits		
Frequency (MHz)	QP (dBuV)	AV (dBuV)
0.15 - 0.50	66 - 56	56 - 46
0.50 - 5.0	56	46
5.0 - 30	60	50

Note 1: The lower limit shall apply at the transition frequencies.

Note 2: The limit decreases linearly with the logarithm of the frequency in the range 0.15MHz to 0.5MHz.

7.8.2. Test Setup

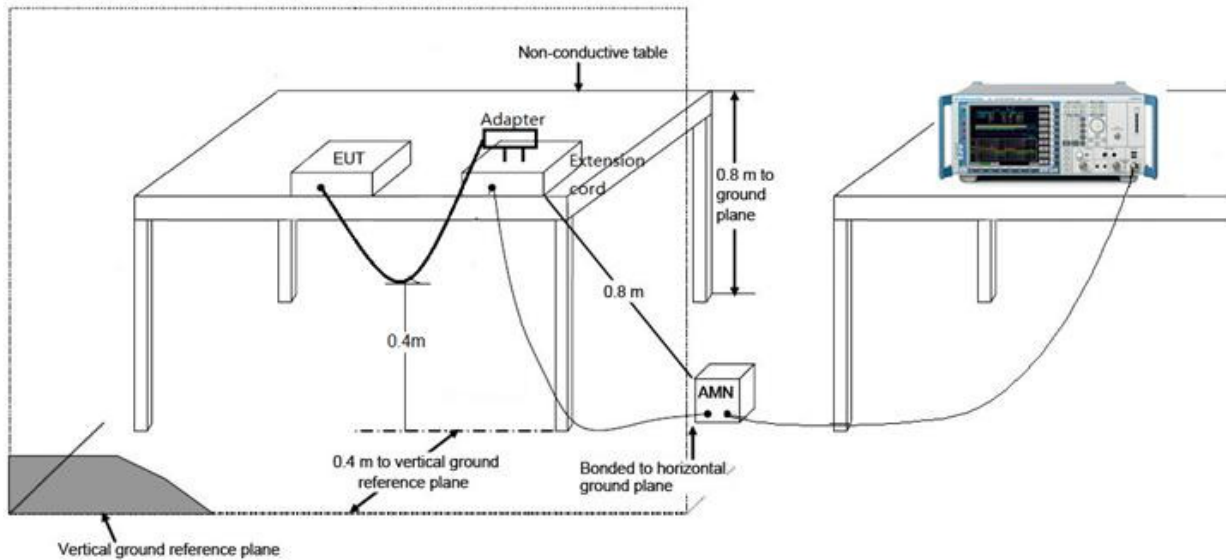

7.8.3. Test Result

Site: SR2	Time: 2017/03/09 - 17:26
Limit: FCC_Part15.207_CE_AC Power	Engineer: Bruce Wang
Probe: ENV216_101683_Filter On	Polarity: Line
EUT: E-reader	Power: AC 120V/60Hz
Test Mode: Mode 1	

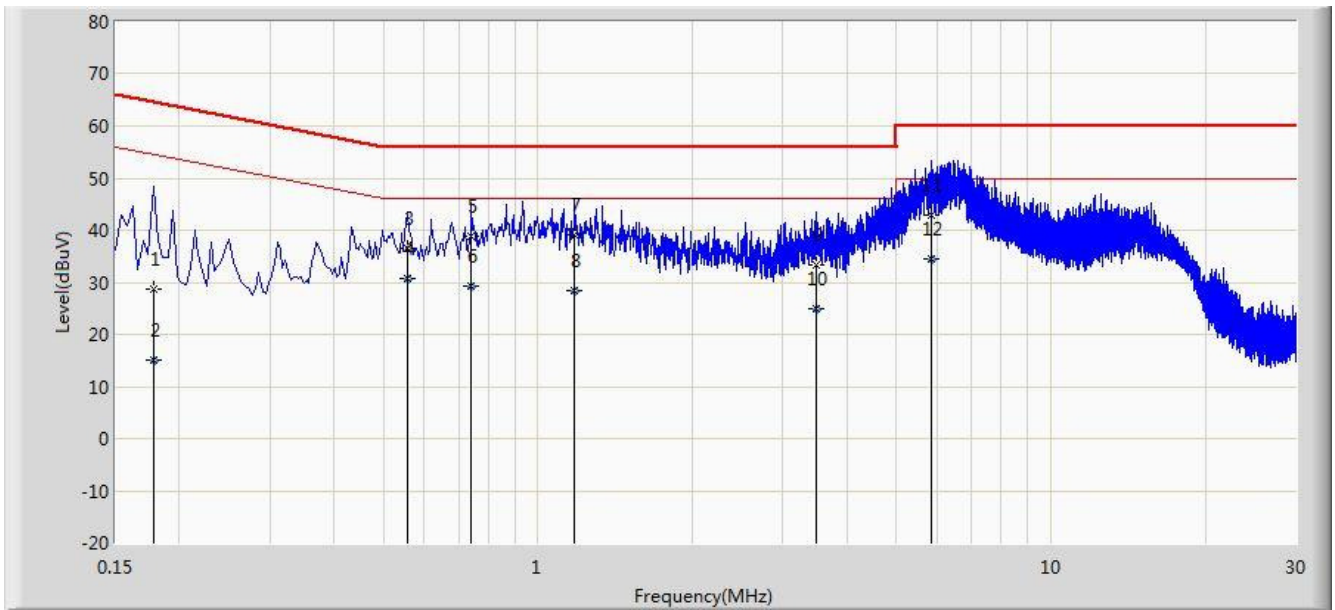

No	Flag	Mark	Frequency (MHz)	Measure Level (dBuV)	Reading Level (dBuV)	Over Limit (dB)	Limit (dBuV)	Factor (dB)	Type
1			0.178	28.750	18.692	-35.829	64.578	10.058	QP
2			0.178	15.181	5.123	-39.397	54.578	10.058	AV
3			0.558	36.561	26.424	-19.439	56.000	10.137	QP
4		*	0.558	30.732	20.595	-15.268	46.000	10.137	AV
5			0.742	38.848	28.807	-17.152	56.000	10.041	QP
6			0.742	29.266	19.225	-16.734	46.000	10.041	AV
7			1.178	39.084	29.182	-16.916	56.000	9.902	QP
8			1.178	28.420	18.518	-17.580	46.000	9.902	AV
9			3.486	33.223	23.316	-22.777	56.000	9.907	QP
10			3.486	24.790	14.883	-21.210	46.000	9.907	AV
11			5.834	43.035	32.939	-16.965	60.000	10.097	QP
12			5.834	34.459	24.362	-15.541	50.000	10.097	AV

Note: Measure Level (dBμV) = Reading Level (dBμV) + Factor (dB)

Factor (dB) = Cable Loss (dB) + LISN Factor (dB)

Site: SR2	Time: 2017/03/09 - 17:31
Limit: FCC_Part15.207_CE_AC Power	Engineer: Bruce Wang
Probe: ENV216_101683_Filter On	Polarity: Neutral
EUT: E-reader	Power: AC 120V/60Hz
Test Mode: Mode 1	

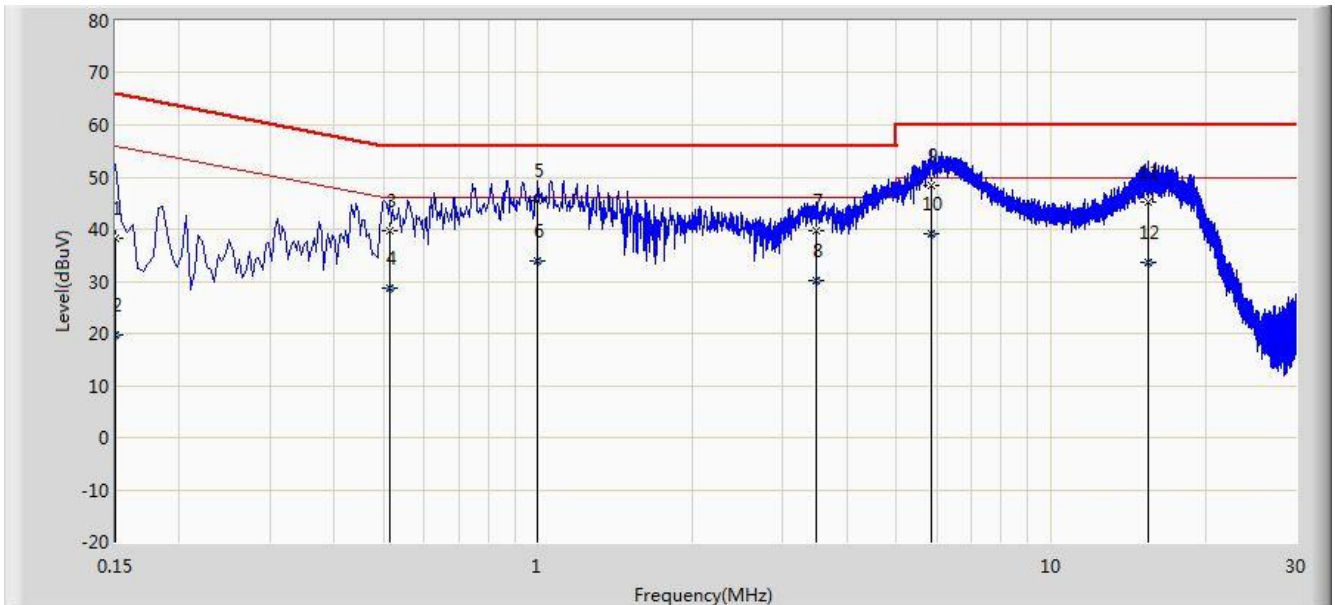

No	Flag	Mark	Frequency (MHz)	Measure Level (dBuV)	Reading Level (dBuV)	Over Limit (dB)	Limit (dBuV)	Factor (dB)	Type
1			0.150	38.282	27.140	-27.718	66.000	11.142	QP
2			0.150	19.698	8.556	-36.302	56.000	11.142	AV
3			0.514	39.821	29.645	-16.179	56.000	10.176	QP
4			0.514	28.780	18.604	-17.220	46.000	10.176	AV
5		*	0.998	45.598	35.688	-10.402	56.000	9.910	QP
6			0.998	34.048	24.138	-11.952	46.000	9.910	AV
7			3.482	39.626	29.714	-16.374	56.000	9.912	QP
8			3.482	30.220	20.307	-15.780	46.000	9.912	AV
9			5.850	48.521	38.413	-11.479	60.000	10.108	QP
10			5.850	39.161	29.053	-10.839	50.000	10.108	AV
11			15.434	45.128	35.009	-14.872	60.000	10.119	QP
12			15.434	33.585	23.466	-16.415	50.000	10.119	AV

Note: Measure Level (dBμV) = Reading Level (dBμV) + Factor (dB)

Factor (dB) = Cable Loss (dB) + LISN Factor (dB)

8. CONCLUSION

The data collected relate only the item(s) tested and show that the **E-reader FCC ID: XR3-C67** is in compliance with Part 15C of the FCC Rules.

The End