



Compliance Testing, LLC
Previously Flom Test Lab
EMI, EMC, RF Testing Experts Since 1963

toll-free: (866) 311-3268
fax: (480) 926-3598

<http://www.ComplianceTesting.com>
info@ComplianceTesting.com

Date: December 24, 2009

Applicant: Fender Musical Instruments Corp.
8860 E. Chaparral Road, Suite 100
Scottsdale, AZ 85250-2618

Attention of: Larry Clauss, Sr. Project Engineer - Compliance
(480) 367-5203; FAX (480) 948-9155
lclauss@fenderusa.com

Equipment: UHF WRLS HH
FCC ID: XQWUHFHHPR601
FCC Rules: Part 74H

Gentlemen:

Enclosed please find your copy of the Engineering Test Report for which you are subject to the restrictions as listed on the attached summary.

Once a Telecommunication Certification Body (TCB) issues a Grant the Federal Communication Commission (FCC) has 30 days to review the application and request added information. It is your decision whether or not to market the equipment subject to a possible recall before the end of the 30 days.

If your equipment is still retained by us, it will be returned to you 30 days after approval is achieved. Our invoice for services has been directed to your Accounts Payable Department.

For any additional information please contact us.

Thank you.

Sincerely yours,

John Erhard: Engineering Manager

Summary of Restrictions

1. All submissions to the FCC are subject to **their** Examiner's interpretation.
2. Please allow from 60 to 90 days before hearing from the FCC with regard to any submission.
3. The FCC can set aside any action; modify or set aside any action, within 30 days. (FCC Rule 1.108, 1.113).
4. Under Rule 2.803, if device is not type accepted/certificated then it must **not** be sold, leased, offered for sale, imported, shipped or distributed or advertised for sale.
5. FCC can revoke its certificates at any time if the equipment does not meet or **continue** to meet their Rules. (Rule Parts 2.927, 2.939).
6. FCC can request a sample at any time (2.936).



Compliance Testing, LLC
Previously Flom Test Lab
EMI, EMC, RF Testing Experts Since 1963

toll-free: (866) 311-3268

fax: (480) 926-3598

<http://www.ComplianceTesting.com>
info@ComplianceTesting.com

Date: December 24, 2009

Federal Communications Commission
Via: Electronic Filing

Attention: Authorization & Evaluation Division

Applicant: Fender Musical Instruments Corp.
Equipment: UHF WRLS HH
FCC ID: XQWUHFHHP601
FCC Rules: Part 74H

Dear Gentleman:

On behalf of the Applicant, enclosed please find Application Form 731, Engineering Test Report and all pertinent documentation, the whole for approval of the referenced equipment as shown.

We trust the same is in order. Should you need any further information, kindly contact the writer who is authorized to act as agent.

Best regards,

John Erhard: Engineering Manager



Compliance Testing, LLC
Previously Flom Test Lab
EMI, EMC, RF Testing Experts Since 1963

toll-free: (866) 311-3268
fax: (480) 926-3598

<http://www.ComplianceTesting.com>
info@ComplianceTesting.com

Test Report

for

Model: UHF WRLS HH

to

Federal Communications Commission

Rule Part(s)

Date of report: December 24, 2009

On the Behalf of the Applicant: Fender Musical Instruments Corp.

At the Request of: Fender Musical Instruments Corp.
8860 E. Chaparral Road, Suite 100
Scottsdale, AZ 85250-2618

Attention of: Larry Clauss, Sr. Project Engineer - Compliance
(480) 367-5203; FAX (480) 948-9155
lclauss@fenderusa.com

John Erhard: Engineering Manager

Reviewed by:

Test Report Revision history

Revision	Date	Revised By	Reason for revision
1.0	December 24, 2009	J. Erhard	Original Document

List of Exhibits

(FCC **Certification** (Transmitters) - Revised 9/28/98)

Applicant: Fender Musical Instruments Corp.

FCC ID: XQWUHFHHPR601

By Applicant:

1. Letter of Authorization
2. Confidentiality Request: 0.457 And 0.459
3. Identification Drawings, 2.1033(c)(11)
 - Label
 - Location of Label
 - Compliance Statement
 - Location of Compliance Statement
4. Photographs, 2.1033(c)(12)
5. Documentation: 2.1033(c)
 - (3) User Manual
 - (9) Tune Up Info
 - (10) Schematic Diagram
 - (10) Circuit Description
 - Block Diagram
 - Parts List
 - Active Devices
6. MPE/SAR Report

By Compliance Testing:

- A. Testimonial & Statement of Certification

The Applicant has been cautioned as to the following:

15.21 Information to the User.

The users manual or instruction manual for an intentional radiator shall caution the user that changes or modifications not expressly approved by the party responsible for compliance could void the user's authority to operate the equipment.

15.27(a) Special Accessories.

Equipment marketed to a consumer must be capable of complying with the necessary regulations in the configuration in which the equipment is marketed. Where special accessories, such as shielded cables and/or special connectors are required to enable an unintentional or intentional radiator to comply with the emission limits in this part, the equipment must be marketed with, i.e. shipped and sold with, those special accessories. However, in lieu of shipping or packaging the special accessories with the unintentional or intentional radiator, the responsible party may employ other methods of ensuring that the special accessories are provided to the consumer, without additional charge.

Information detailing any alternative method used to supply the special accessories for a grant of equipment authorization or retained in the verification records, as appropriate. The party responsible for the equipment, as detailed in § 2.909 of this chapter, shall ensure that these special accessories are provided with the equipment. The instruction manual for such devices shall include appropriate instructions on the first page of text concerned with the installation of the device that these special accessories must be used with the device. It is the responsibility of the user to use the needed special accessories supplied with the equipment.

Testimonial and Statement of Certification

This is to Certify:

1. **That** the application was prepared either by, or under the direct supervision of, the undersigned.
2. **That** the technical data supplied with the application was taken under my direction and supervision.
3. **That** the data was obtained on representative units, randomly selected.
4. **That**, to the best of my knowledge and belief, the facts set forth in the application and accompanying technical data are true and correct.



John Erhard: Engineering Manager

Certifying Engineer:

Table of Contents

<u>Rule</u>	<u>Description</u>	<u>Page</u>
	Test Report	2
2.1033(c)(14)	Rule Summary	3
	Standard Test Conditions and Engineering Practices	4
2.1033(c)	General Information Required	5
	Test Results Summary	7
74.861(1)(ii)	Carrier Output Power (Conducted)	8
74.861(6)(iii)	Conducted Spurious Emissions	9
2.1053(a)	Field Strength of Spurious Radiation	13
74.861(6)	Emission Masks (Occupied Bandwidth)	16
2.1047(a)	Audio Frequency Response	20
74.861(3)	Modulation Limiting	21
74.861(4)	Frequency Stability (Temperature Variation)	24
74.861(5)	Necessary Bandwidth and Emission Bandwidth	25
	Test Equipment Utilized	26

Required information per ISO 17025-2005, paragraph 5.10.2:

a) **Test Report**

b) Laboratory: Compliance Testing
 (FCC: 31040/SIT) 3356 N. San Marcos Place, Suite 107
 (Canada: IC 2044-A) Chandler, AZ 85225

c) Report Number: d09c0010

d) Client: Fender Musical Instruments Corp.
 8860 E. Chaparral Road, Suite 100
 Scottsdale, AZ 85250-2618

e) Identification: UHF WRLS HH
 EUT Description: UHF WRLS Hand-held Microphone

f) EUT Condition: Not required unless specified in individual tests.

g) Report Date: December 24, 2009

h, j, k): As indicated in individual tests.

i) Sampling method: No sampling procedure used.

l) Measurement Uncertainty: In accordance with Compliance Testing internal quality manual.

m) Reviewed by:



John Erhard: Engineering Manager

n) Results: The results presented in this report relate only to the item tested.

o) Reproduction: This report must not be reproduced, except in full, without written permission from this laboratory.

Accessories used during testing:

Type	Quantity	Manufacturer	Model	Serial No.	FCC ID
------	----------	--------------	-------	------------	--------

Sub-part

2.1033(c)(14):

Test and Measurement Data

All tests and measurement data shown were performed in accordance with FCC Rules and Regulations, Volume II; Part 2, Sub-part J, Sections 2.947, 2.1033(c), 2.1041, 2.1046, 2.1047, 2.1079, 2.1051, 2.1053, 2.1055, 2.1057 and the following individual Parts: 74H

Standard Test Conditions and Engineering Practices

Except as noted herein, the following conditions and procedures were observed during the testing:

In accordance with ANSI/C63.4-2009 with EIA/TIA 603 as a measurement guide, unless otherwise indicated in the specific measurement results, the ambient temperature of the actual EUT was maintained within the range of 10° to 40°C (50° to 104 °F) unless the particular equipment requirements specify testing over a different temperature range. Also, unless otherwise indicated, the humidity levels were in the range of 10% to 90% relative humidity.

Measurement results, unless otherwise noted, are worst-case measurements.

A2LA

“A2LA has accredited Compliance Testing in Chandler, AZ for technical competence in the field of Electrical testing. The accreditation covers the specific tests and types of tests listed on the agreed scope of accreditation. This laboratory meets the requirements of ISO 17025:2005 ‘General Requirements for the Competence of Testing and Calibration Laboratories’ and any additional program requirements in the identified field of testing.”

Please refer to www.a2la.org for current scope of accreditation.

Certificate number: 2152.01



FCC OATS Reg. #933597

IC Reg. # 2044A-1

List of General Information Required for Certification

In Accordance with FCC Rules and Regulations,
Volume II, Part 2 and to Part 74H

Sub-part 2.1033

(c)(1):

Name and Address of Applicant: Fender Musical Instruments Corp.
8860 E. Chaparral Road, Suite 100
Scottsdale, AZ 85250-2618

Manufacturer: Fender Musical Instruments Corp.
8860 E. Chaparral Road, Suite 100
Scottsdale, AZ 85250-2618

(c)(2): **FCC ID:** XQWUHFHHPR601

Model Number: UHF WRLS HH

(c)(3): **Instruction Manual(s):**

Please see attached exhibits

(c)(4): **Type of Emission:** FM

(c)(5): **Frequency Range, MHz:** 621.85 – 642.75

(c)(6): **Power Rating, Watts:** 0.0316
 ___ Switchable ___ Variable x N/A

FCC Grant Note: None

(c)(7): **Maximum Allowable Power, Watts:** 0.250

EUT Results: Passes x Fails _____

Subpart 2.1033 (continued)

(c)(8): Voltages & currents in all elements in final RF stage, including final transistor or solid-state device:

Collector Current, A	=	.01
Collector Voltage, Vdc	=	5
Supply Voltage, Vdc	=	9

(c)(9): **Tune-Up Procedure:**

Please see attached exhibits

(c)(10): **Circuit Diagram/Circuit Description:**

Including description of circuitry & devices provided for determining and stabilizing frequency, for suppression of spurious radiation, for limiting modulation and limiting power.

Please see attached exhibits

(c)(11): **Label Information:**

Please see attached exhibits

(c)(12): **Photographs:**

Please see attached exhibits

(c)(13): **Digital Modulation Description:**

Attached Exhibits
 N/A

(c)(14): **Test and Measurement Data:**

Follows

Test Results Summary

Specification	Test Name	Pass, Fail, N/A	Comments
74.861(1)(ii)	Carrier Output Power (Conducted)	Pass	
74.861(6)(iii)	Unwanted Emissions (Transmitter Conducted)	Pass	
2.1046(a)	RF Power Output (Radiated)	Pass	
2.1053(a)	Field Strength of Spurious Radiation	Pass	
74.861(6)	Emission Masks (Occupied Bandwidth)	Pass	
2.1047(a)	Audio Low Pass Filter	N/A	The EUT does not contain an audio low pass filter
2.1047(a)	Audio Frequency Response	Pass	
74.861(3)	Modulation Limiting	Pass	
74.861(4)	Frequency Stability	Pass	
74.861(5)	Necessary Bandwidth and Emission Bandwidth	Pass	

Name of Test: Carrier Output Power (Conducted)
Specification: 74.861(1)(ii)
Test Equipment Utilized: i00008, i00331

Engineer: J. Erhard
Test Date: 12/18/2009

Measurement Procedure

The Equipment Under Test (EUT) was connected directly to a spectrum analyzer input with the RBW set at least 3X the occupied bandwidth of the signal being measured. The VBW was set to 3X the RBW. The peak readings were taken and the result was then compared to the limit.

Test Setup

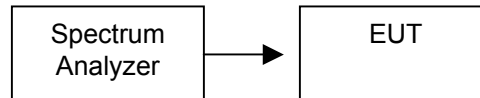

Transmitter Peak Output Power

Tuned Frequency MHz	Measured Value (dBm)	Measured Value (mW)	Specification Limit	Result
621.85	14.7	29.5	250 mW	Pass
628.15	15.0	31.6	250 mW	Pass
642.75	12.7	18.6	250 mW	Pass

Name of Test: Conducted Spurious Emissions
Specification: 74.861(6)(iii)
Test Equipment Utilized: i00008, i00331

Engineer: J. Erhard
Test Date: 12/20/2009

Test Procedure

The EUT was connected directly to a spectrum analyzer to verify that the EUT met the requirements for spurious emissions. The frequency range from 30 MHz to the 10th harmonic of the fundamental transmitter was observed. A tunable notch filter was utilized to ensure the fundamental transmitter frequency did not put the spectrum analyzer into compression causing erroneous measurements. The emissions limit from RSS-123 was utilized to ensure Industry Canada Compliance.

Only the worst case spurious for each frequency is recorded in the Conducted Spurious Emissions Summary Test Table.

Test Setup

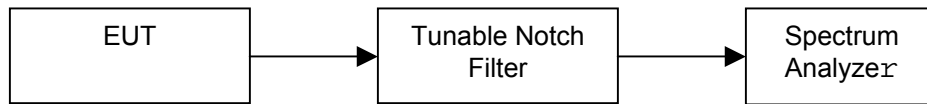

Conducted Spurious Emissions Summary Test Table

Tuned Frequency (MHz)	Spurious Frequency (MHz)	Measured Spurious Level (dBm)	Limit (dBm)	Result
621.85	1240	-42.03	-25	Pass
628.15	1255	-44.82	-25	Pass
642.75	1285	-42.02	-25	Pass

Conducted Spurious Emissions 621.85 MHz Plots

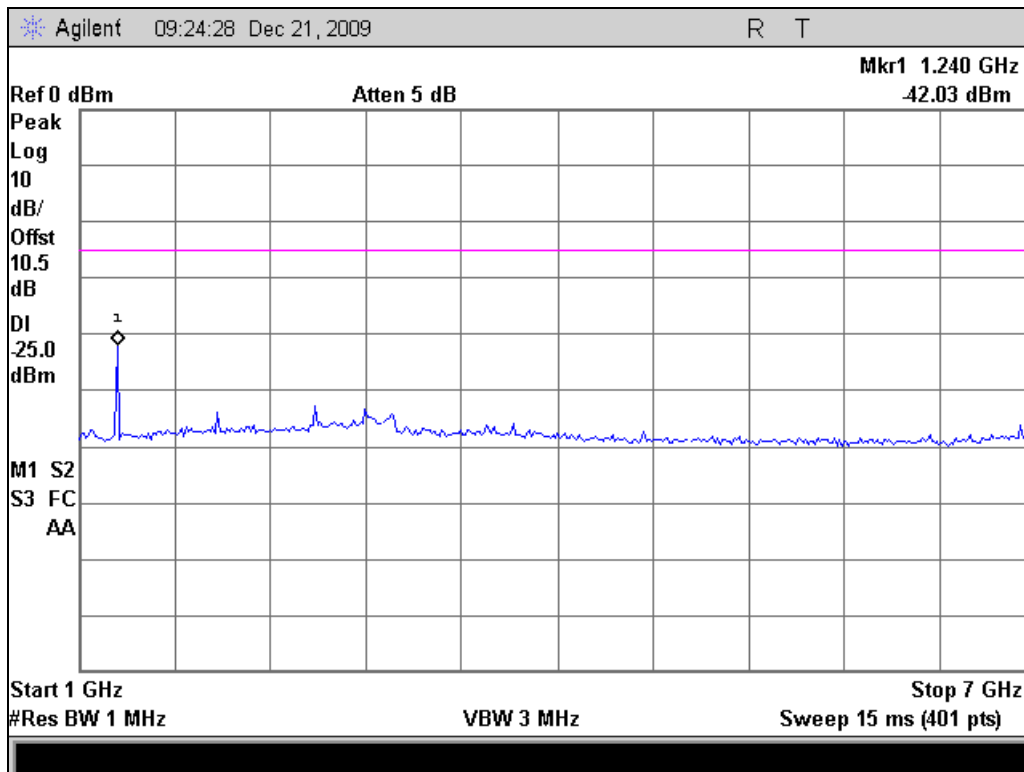
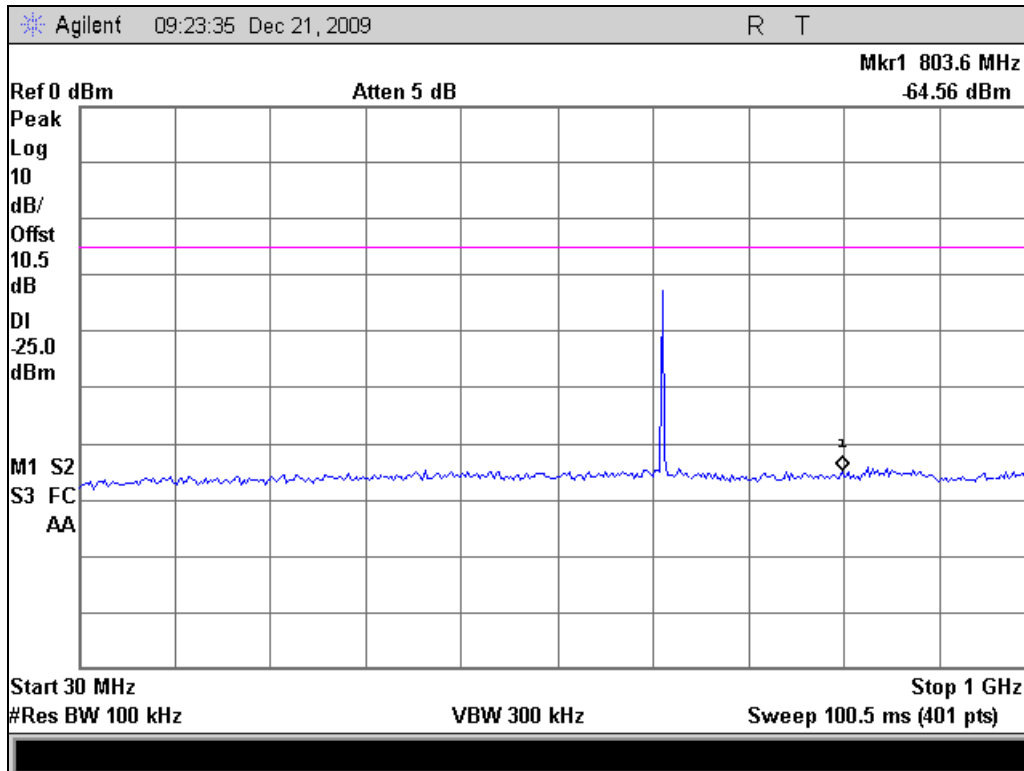

Conducted Spurious Emissions 628.15 MHz Plots

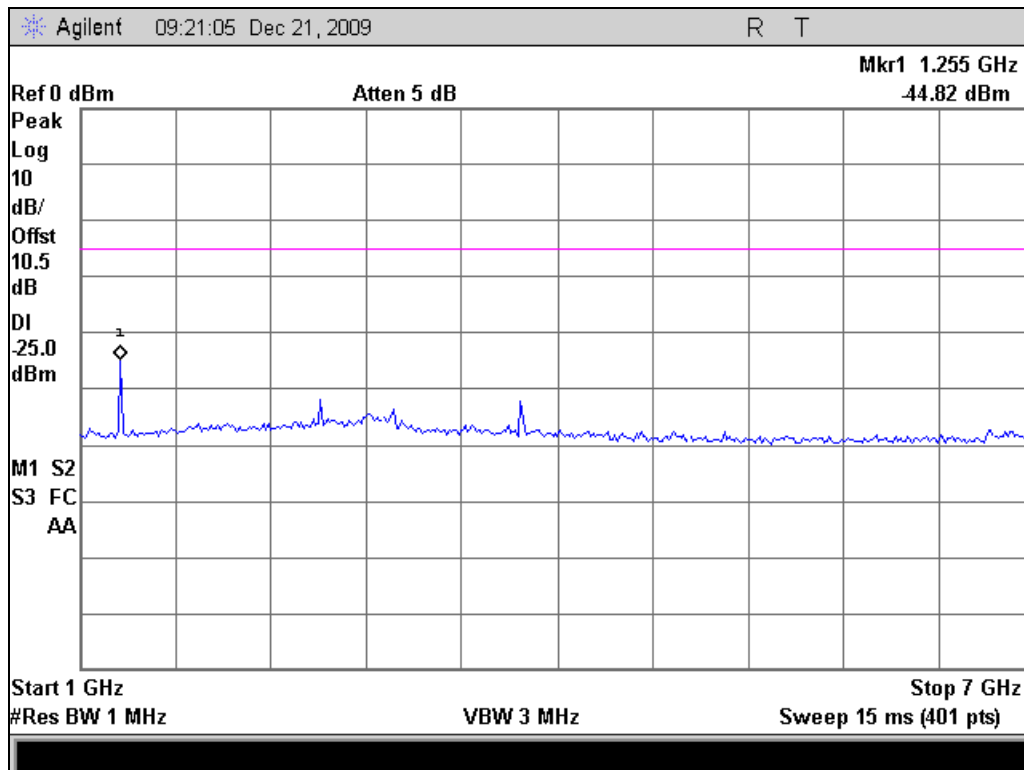
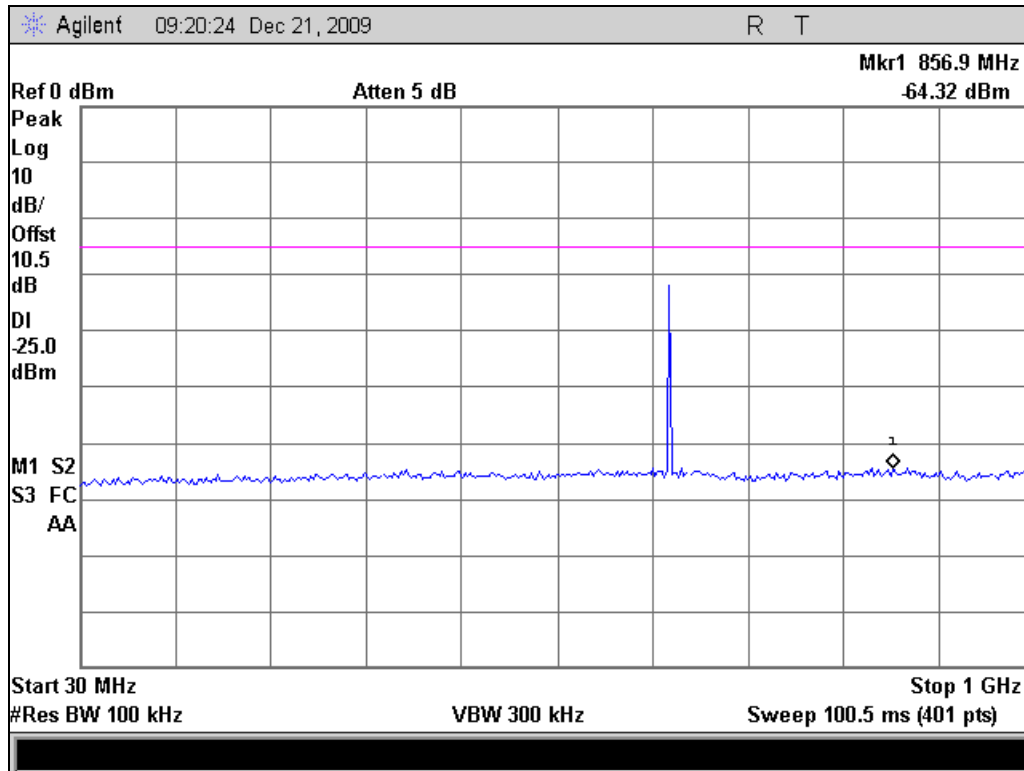

Conducted Spurious Emissions 642.75 MHz Plots

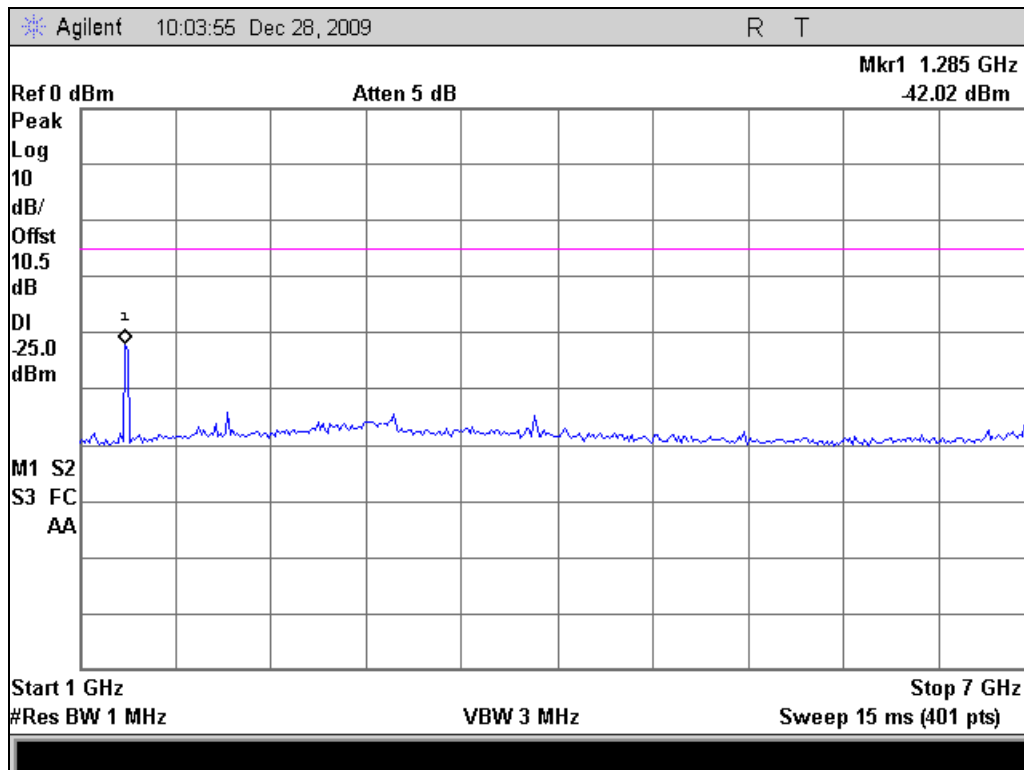
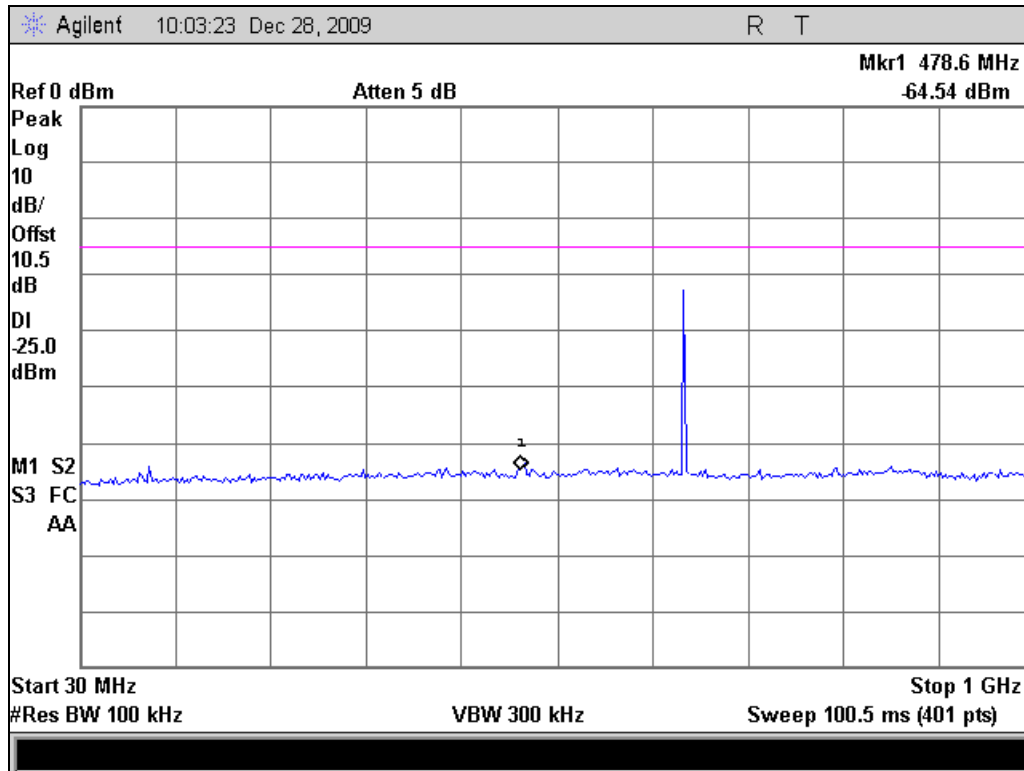

Name of Test: Field Strength of Spurious Radiation
Specification: 2.1053(a)
Test Equipment Utilized: i00008, i0003, 39, 42, 48, i00041, i00049, i00103, i00348

Engineer: J. Erhard
Test Date: 12/22/2009

Measurement Procedure

Definition:

Radiated spurious emissions are emissions from the equipment when transmitting into a non-radiating load on a frequency or frequencies, which are outside an occupied band sufficient to ensure transmission of information of required quality for the class of communications desired.

Method of Measurement:

- A) Connect the equipment as illustrated
- B) Adjust the spectrum analyzer for the following settings:
 - 1) Resolution Bandwidth 100 kHz (<1 GHz), 1 MHz (> 1GHz).
 - 2) Video Bandwidth ≥ 3 times Resolution Bandwidth, or 30 kHz
 - 3) Sweep Speed ≤ 2000 Hz/second
 - 4) Detector Mode = Mean or Average Power
- C) Place the transmitter to be tested on the turntable in the standard test site. The transmitter is transmitting into a non-radiating load that is placed on the turntable. The RF cable to this load should be of minimum length.
- D) For each spurious measurement the test antenna should be adjusted to the correct length for the frequency involved. This length may be determined from a calibration ruler supplied with the equipment. Measurements shall be made from the lowest radio frequency generated in the equipment to the tenth harmonic of the carrier, except for the region close to the carrier equal to \pm the test bandwidth (see section 1.3.4.4).
- E) For each spurious frequency, raise and lower the test antenna from 1 m to 4 m to obtain a maximum reading on the spectrum analyzer with the test antenna at horizontal polarity. Repeat this procedure to obtain the highest possible reading. Record this maximum reading.
- F) Repeat step E) for each spurious frequency with the test antenna polarized vertically.
- G) Reconnect the equipment as illustrated.
- H) Keep the spectrum analyzer adjusted as in step B).
- I) Remove the transmitter and replace it with a substitution antenna (the antenna should be half-wavelength for each frequency involved). The center of the substitution antenna should be approximately at the same location as the center of the transmitter. At lower frequencies, where the substitution antenna is very long, this will be impossible to achieve when the antenna is polarized vertically. In such case the lower end of the antenna should be 0.3 m above the ground.
- J) Feed the substitution antenna at the transmitter end with a signal generator connected to the antenna by means of a non-radiating cable. With the antennas at both ends horizontally polarized and with the signal generator tuned to a particular spurious frequency, raise and lower the test antenna to obtain a maximum reading at the spectrum analyzer. Adjust the level of the signal generator output until the previously recorded maximum reading for this set of conditions is obtained. This should be done carefully repeating the adjustment of the test antenna and generator output.
- K) Repeat step J) with both antennas vertically polarized for each spurious frequency.
- L) Calculate power in dBm into a reference ideal half-wave dipole antenna by reducing the readings obtained in steps J) and K) by the power loss in the cable between the generator and the antenna and further corrected for the gain of the substitution antenna used relative to an ideal half-wave dipole antenna.
- M) The levels recorded in step L) are absolute levels of radiated spurious emissions in dBm. The radiated spurious emissions in dB can be calculated by the following:

Radiated spurious emissions dB =
 $10\log_{10}(\text{TX power in watts}/0.001) - \text{the levels in step I)}$

NOTE: It is permissible that other antennas provided can be referenced to a dipole.

Substitution Method Test Setup

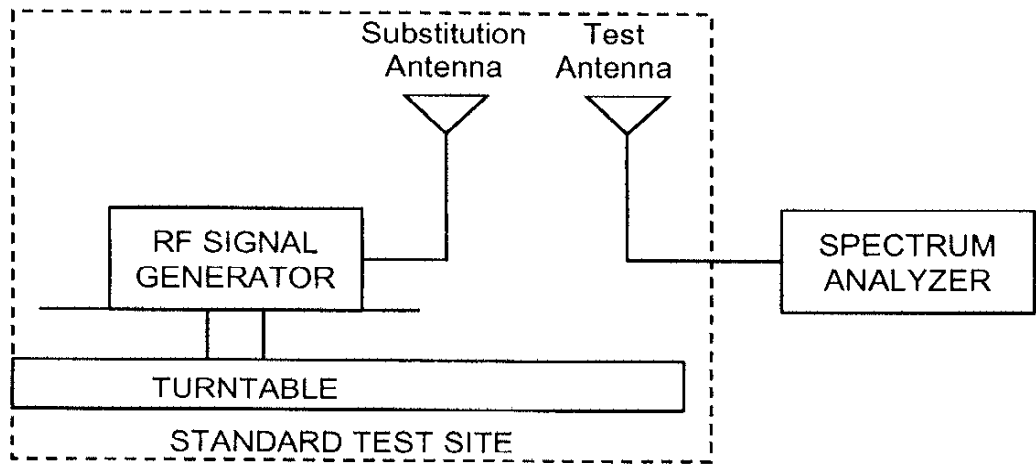
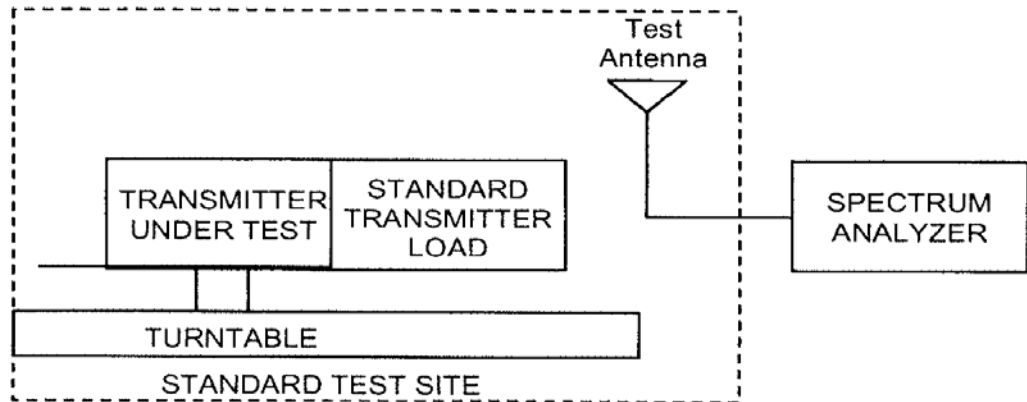

Radiated Output Power

Measured Frequency (MHz)	Signal Generator Level (dBm)	Amplifier Gain (dB)	Cable Loss (dB)	Substitute Antenna Gain (dB)	Output Power ERP (dBm)
621.85	-29.6	50.6	0.9	0	20.1
628.15	-29.4	50.6	0.9	0	20.3
642.75	-30.3	50.6	0.9	0	19.4

Test Results 621.85 MHz

Emission Frequency (MHz)	Measured Level (dBm)	Correction Factor (dB)	Corrected Value (dBm)	Limit (dBm)	Result
1243.7	-33.5	-3	-36.5	-25	Pass
1865.55	-71.8	0.5	-71.3	-25	Pass
2487.4	-69.2	4.7	-64.5	-25	Pass
3109.25	-71.4	6.8	-64.6	-25	Pass

Test Results 628.15 MHz

Emission Frequency (MHz)	Monitored Level (dBm)	Correction Factor (dB)	Corrected Value (dBm)	Limit (dBm)	Result
1256.3	-35.2	-3	-38.2	-25	Pass
1884.45	-67.7	0.5	-67.2	-25	Pass
2512.6	-70.1	4.7	-65.4	-25	Pass
3140.75	-73.3	6.8	-66.5	-25	Pass

Test Results 642.75 MHz

Emission Frequency (MHz)	Monitored Level (dBm)	Correction Factor (dB)	Corrected Value (dBm)	Limit (dBm)	Result
1285.5	-41.3	-3	-44.3	-25	Pass
1928.25	-68.6	0.5	-68.1	-25	Pass
2571	-74.1	4.7	-69.4	-25	Pass
3213.75	-71.3	6.8	-64.5	-25	Pass

Name of Test: Emission Masks (Occupied Bandwidth)
Specification: 74.861(6)
Test Equipment Utilized: i00008, i00331

Engineer: J. Erhard
Test Date: 12/20/2009

The EUT was connected directly to a spectrum analyzer to verify that it meets the required emissions mask. A reference level plot is provided to verify that the peak power was established prior to testing the mask. The signal was modulated with a 2.5 kHz tone set to achieve peak deviation.

Test Setup



621.85 MHz Occupied Bandwidth Reference

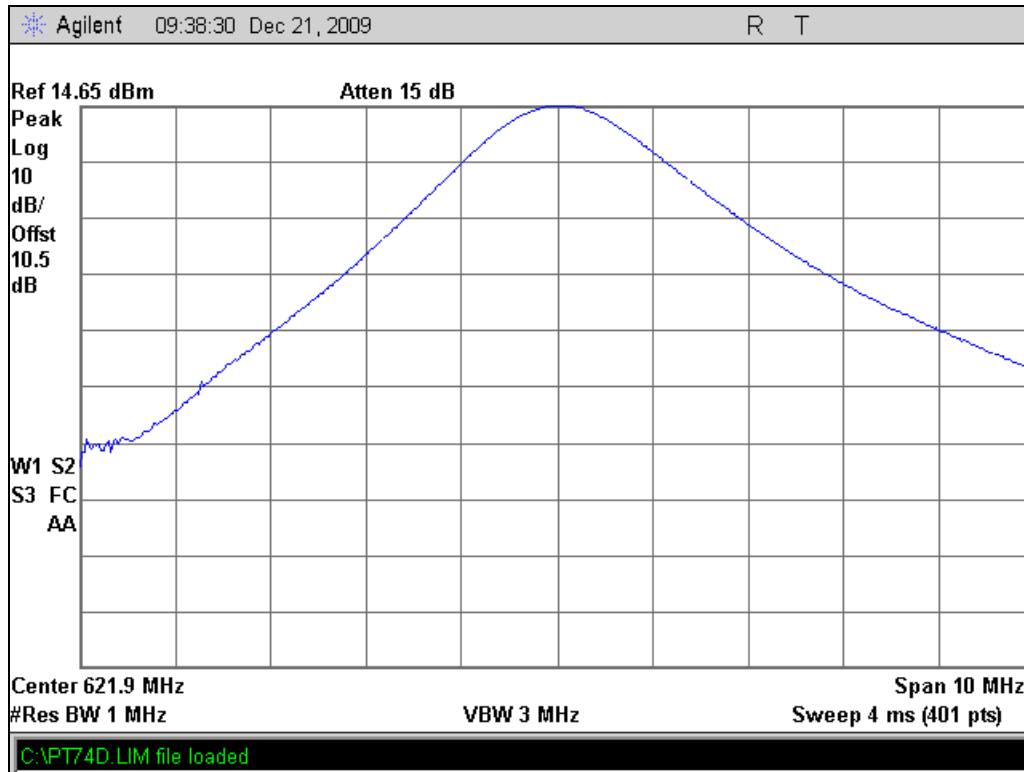

621.85 MHz Occupied Bandwidth Mask

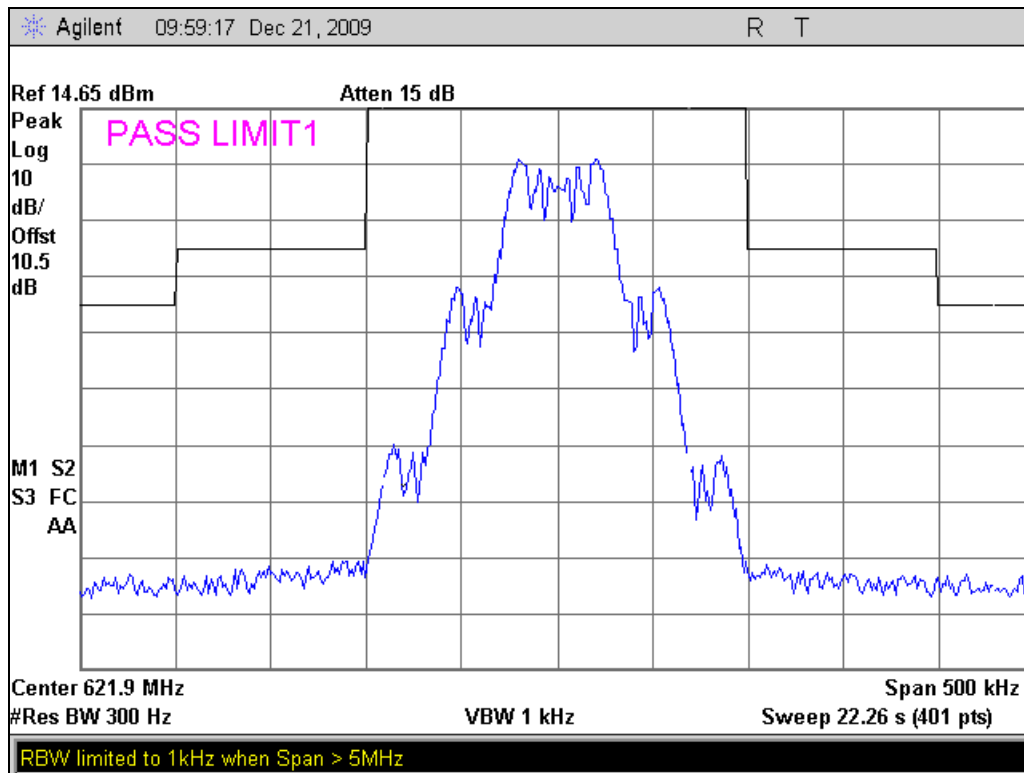

628.15 MHz Occupied Bandwidth Reference

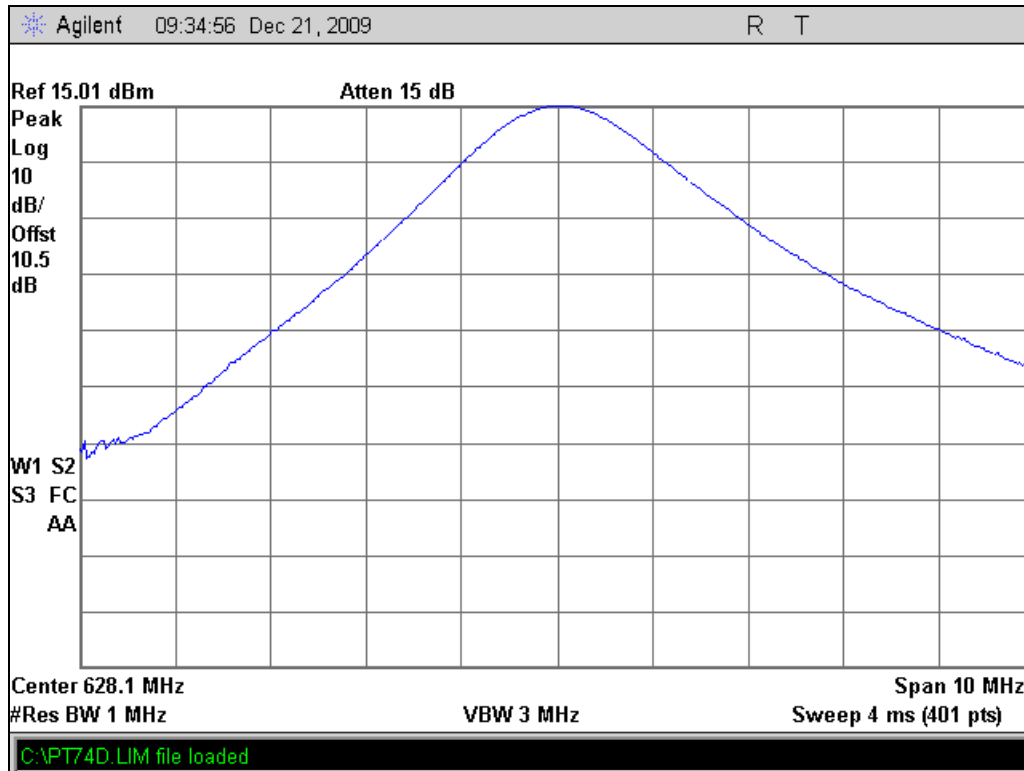

628.15 MHz Occupied Bandwidth Mask

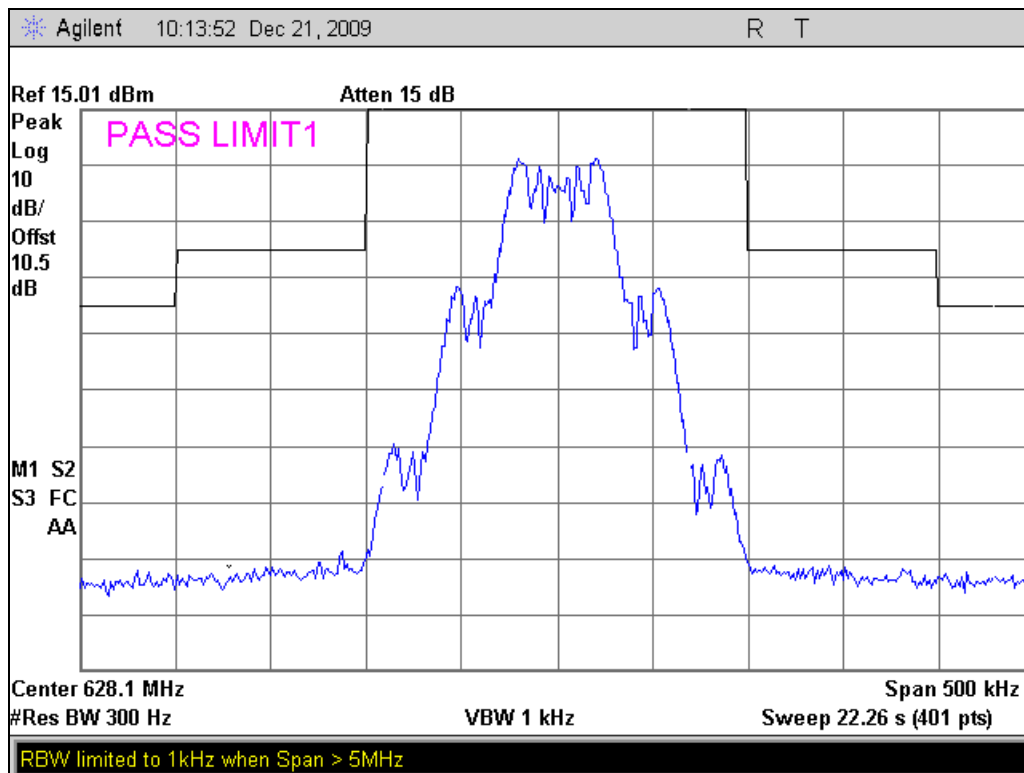

642.75 MHz Occupied Bandwidth Reference

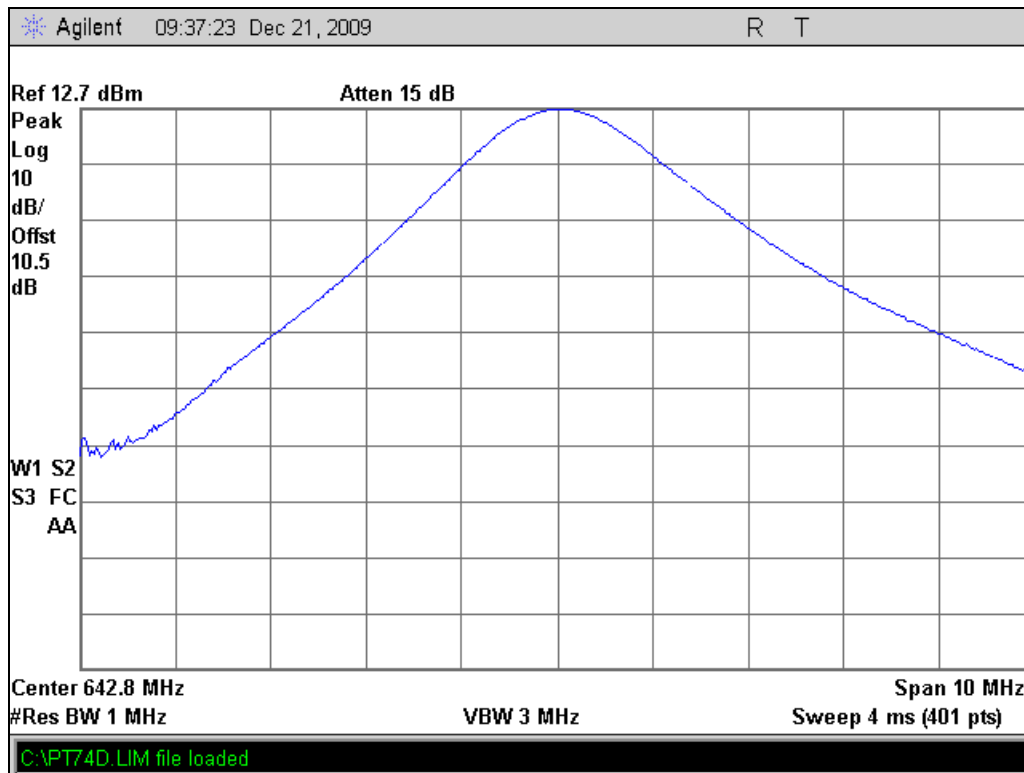

642.75 MHz Occupied Bandwidth Mask

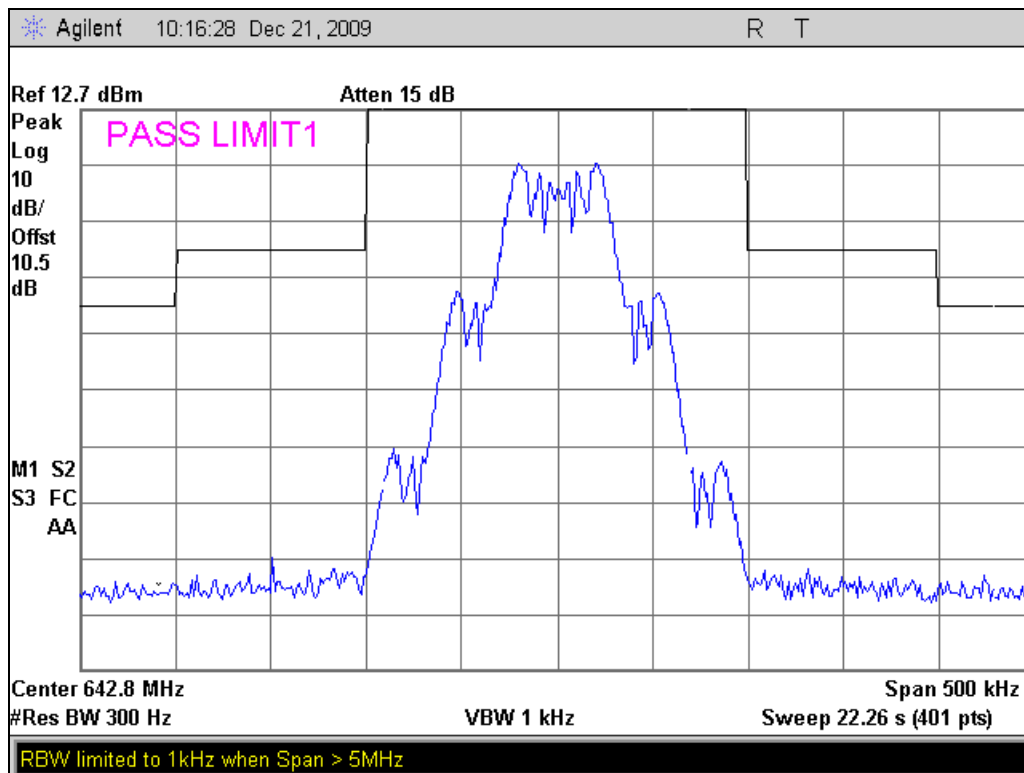

Name of Test: Audio Frequency Response
Specification: 2.1047(a)
Test Equipment Utilized: i00008, i00020, i00324

Engineer: J Erhard
Test Date: 12/21/2009

Measurement Procedure

- A) The EUT and test equipment were set up as shown below.
- B) The audio signal generator was connected to the audio input circuit/microphone of the EUT.
- C) The audio signal input was adjusted to obtain 20% modulation at 1 kHz, and this point was taken as the 0 dB reference level.
- D) With input levels held constant and below limiting at all frequencies, the audio signal generator was varied from 100 Hz to 50 kHz.
- E) The response in dB relative to 1 kHz was measured, using the HP 8901A Modulation Meter.

Transmitter Test Set-Up

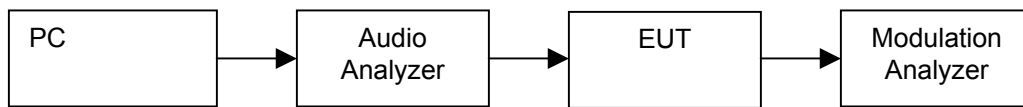

Measurement Results

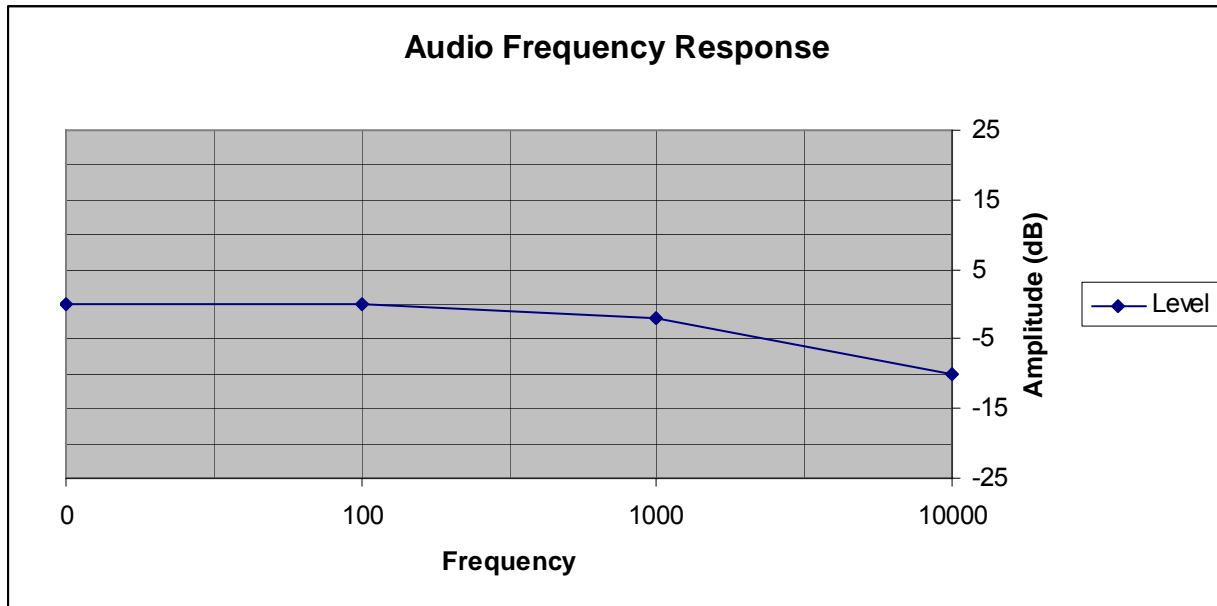

Name of Test: Modulation Limiting
Specification: 74.861(3)
Test Equipment Utilized: i00008, i00020, i00324

Engineer: J Erhard
Test Date: 12/21/2009

Measurement Procedure

- A) The signal generator was connected to the input of the EUT as shown below.
- B) The modulation response was measured for each of three frequencies (one of which was the frequency of maximum response), and the input voltage was varied and was observed on an HP 8901A Modulation Analyzer.
- C) The input level was varied from 30% modulation (± 1.5 kHz deviation) to at least 20 dB higher than the saturation point.
- D) Measurements were performed for both negative and positive modulation and the respective results were recorded.

Transmitter Test Set-Up

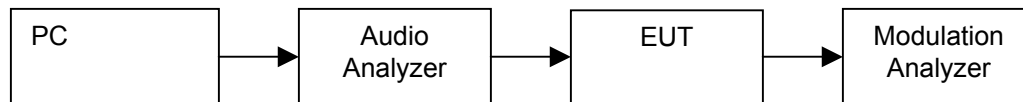

Swept Frequency Positive Peaks

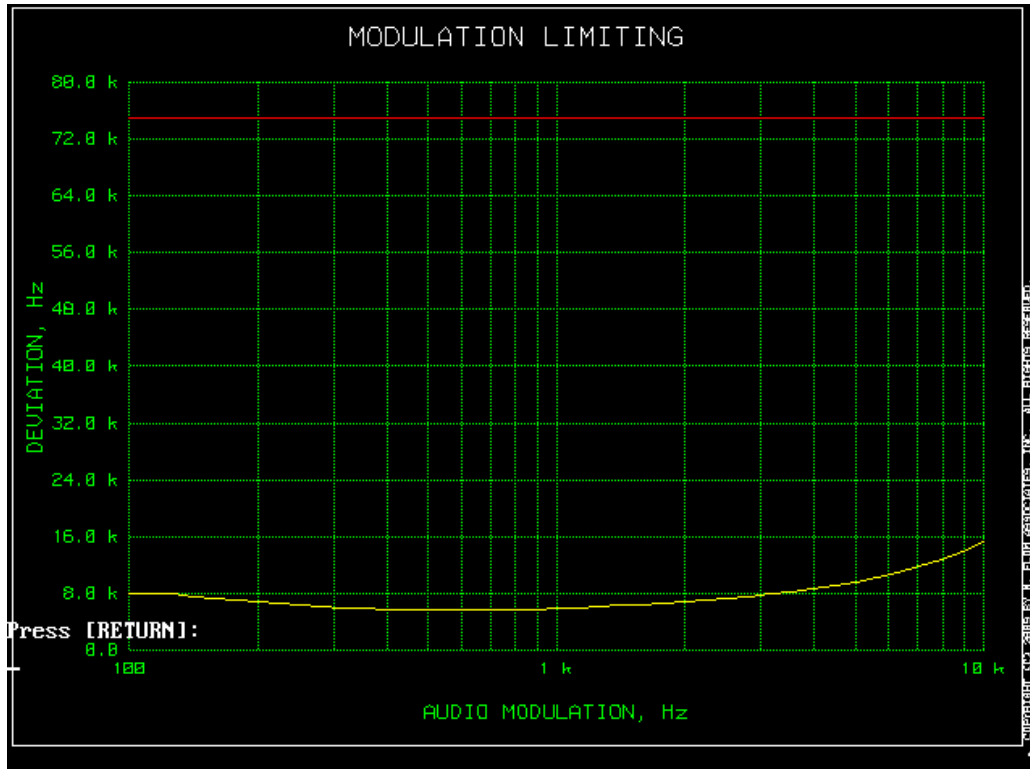

Swept Frequency Negative Peaks

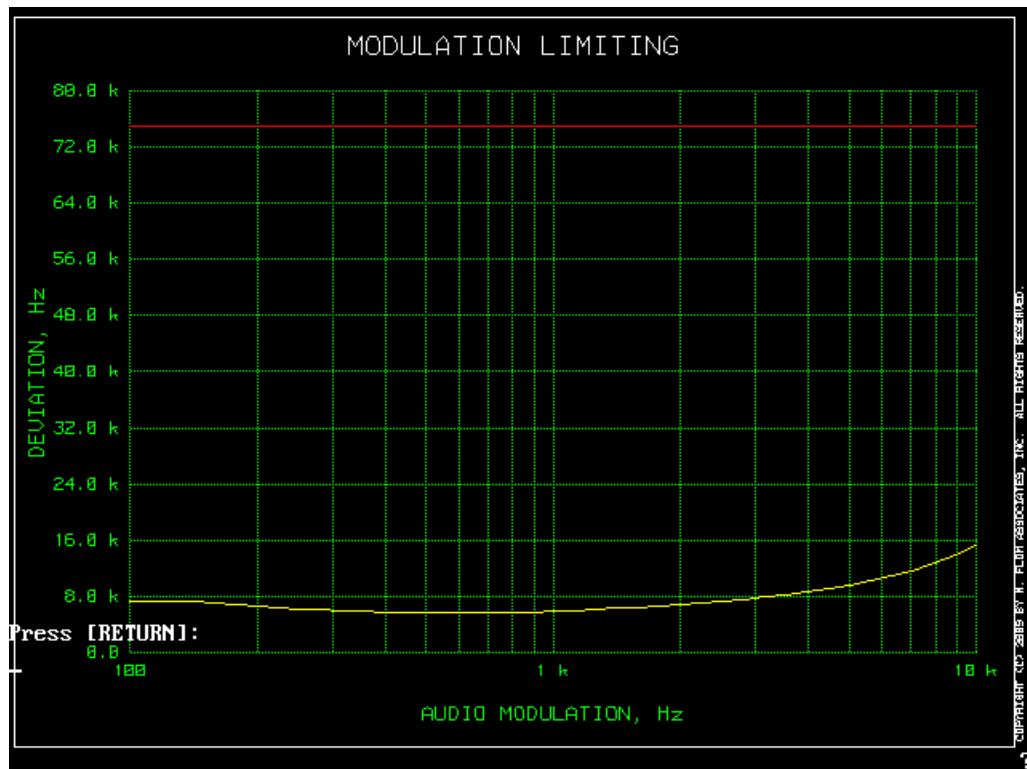

Swept Amplitude Positive Peaks

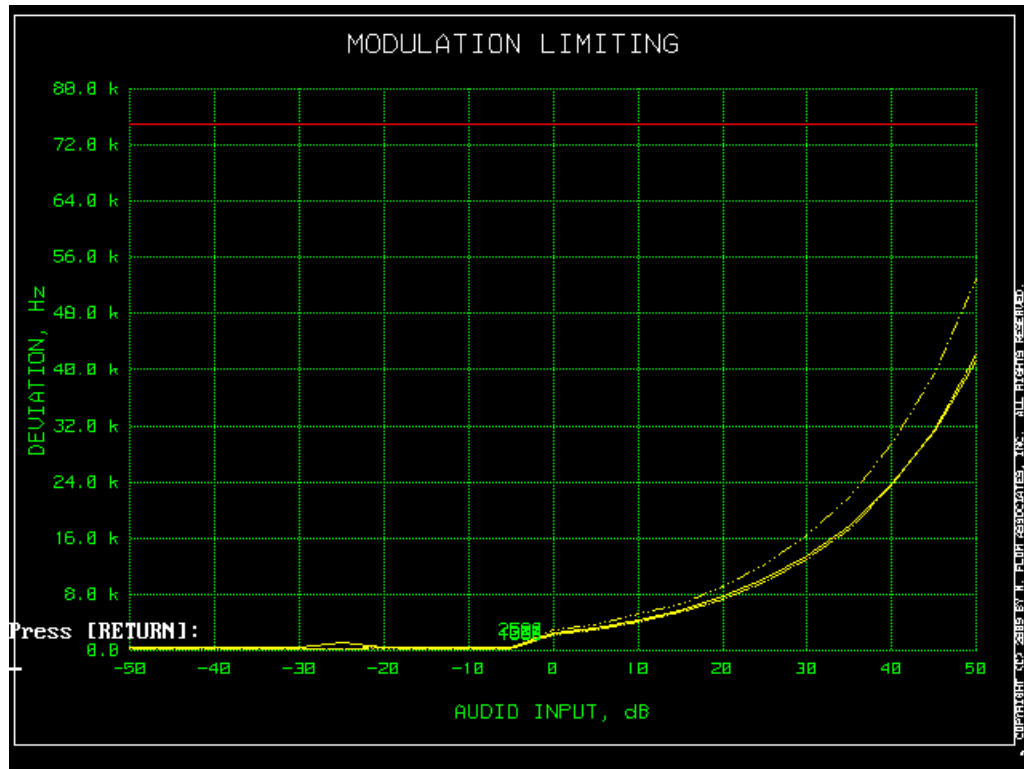

Swept Amplitude Negative Peaks

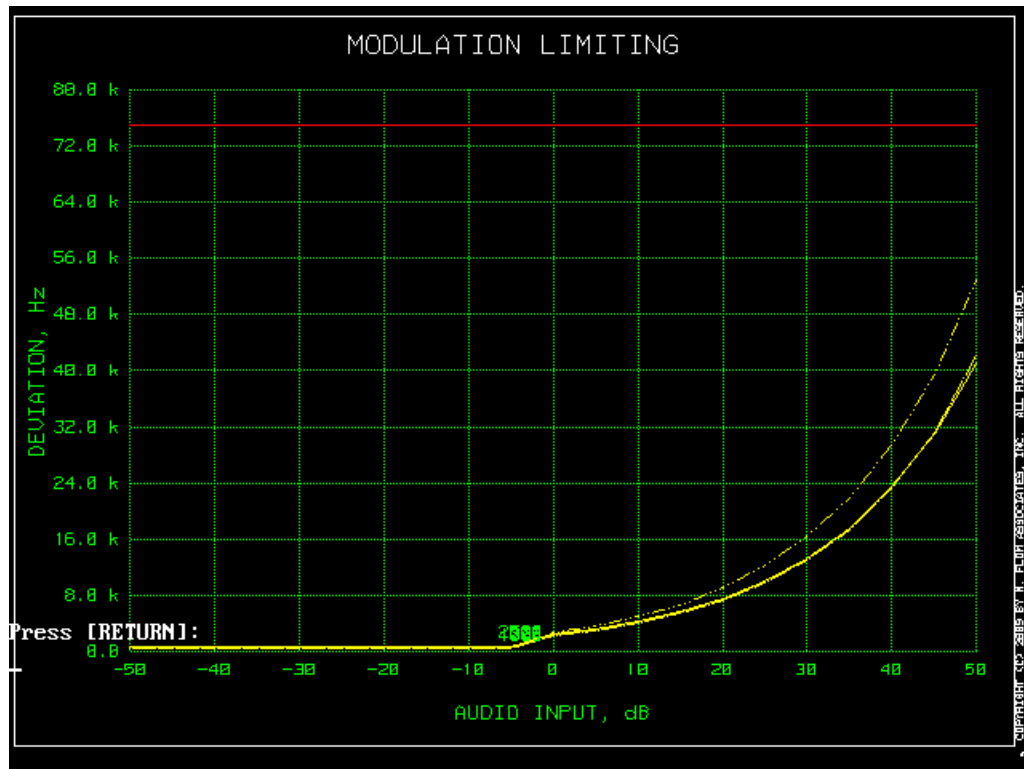

Name of Test: Frequency Stability
Specification: 74.861(4)
Test Equipment Utilized: i00008, i00019, i00027, i00319

Engineer: J Erhard
Test Date: 12/22/2009

Measurement Procedure

The EUT was placed in an environmental test chamber and the RF output was connected directly to a frequency counter. The temperature was varied from -30°C to 50°C in 10°C increments. After a sufficient time for temperature stabilization the RF output frequency was measured. At 20°C the control voltage was varied +/- 15%.

Measurement Setup



Measurement Results

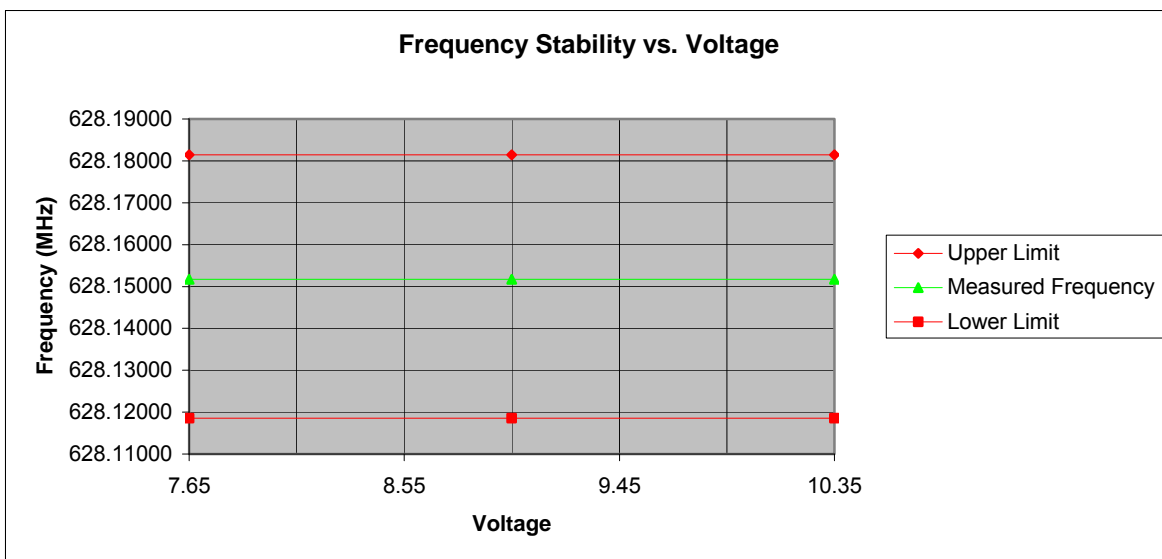
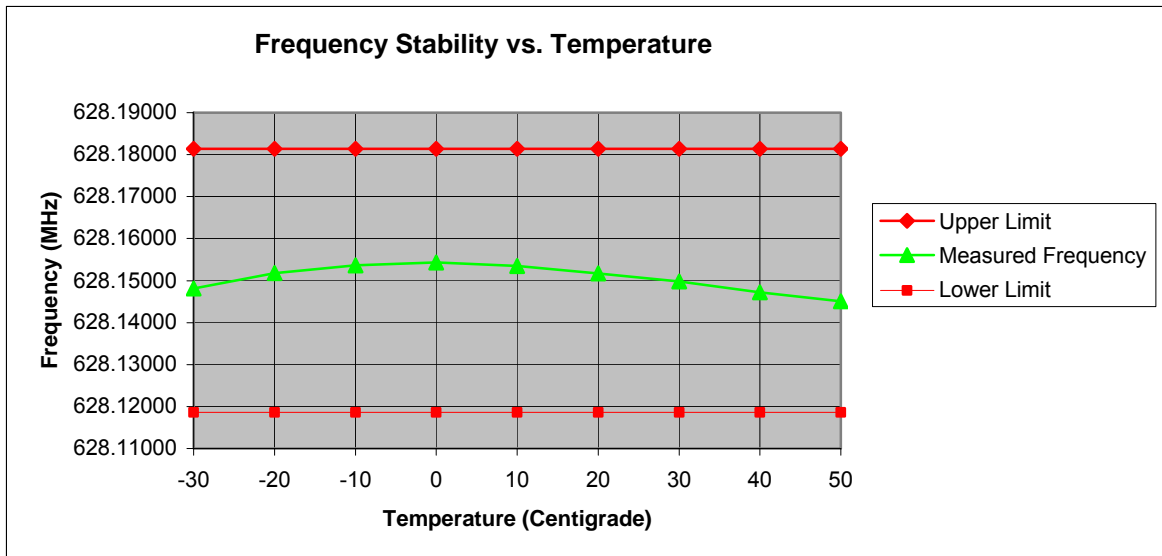

Name of Test: Necessary Bandwidth and Emission Bandwidth
Specification: 74.861(5) **Engineer: J Erhard**

Modulation = 91K0F3E

Necessary Bandwidth Calculation:

Maximum Modulation (M), kHz=	15
Maximum Deviation (D), kHz=	30.5
Constant Factor (K) =	1
Formula	$(2 \times M) + (2 \times D \times K)$
Necessary Bandwidth (B_N), kHz =	91.0

Test Equipment Utilized

Description	MFG	Model Number	FTL Asset Number	Last Cal Date	Cal Due Date
Power Supply	Kenwood	PR18-3A	i00008	NCR	NCR
Frequency Counter	HP	5334B	i00019	1/9/2009	1/9/2010
Modulation Analyzer	HP	8901A	i00020	2/5/2009	2/5/2010
Temperature Chamber	Tenney	Tenney Jr.	i00027	12/8/2009	12/8/2010
Monopole Antenna Set	Ailtech	DM-105A-T1, T2, T3	i0003, 39, 42, 48	Verify	Verify
Amplifier	Amp Research	50W1000A	i00041	Verify	Verify
Spectrum Analyzer	HP	8566B	i00049	10/09/2009	10/09/2010
Horn Antenna	EMCO	3115	i00103	11/25/2008	11/25/2010
Function Generator	HP	33120A	i00118	Verify	Verify
Dipole Antenna	Ailtech	DM-105A-T3	i00142	Verify	Verify
Voltmeter	Fluke	87III	i00319	6/08/09	6/8/2010
Audio Analyzer	HP	8903A	i00324	11/04/09	11/04/2010
Spectrum Analyzer	Agilent	E4407B	i00331	11/03/09	11/03/2010
Signal Generator	Agilent	E4438C	i00348	NCR	NCR
Bi Log Antenna	Schaffner	CBL 6111D	i00349	6/26/2009	6/26/2010
Power Supply	HP	6654A	i00350	NCR	NCR
Tunable Notch Filter	Eagle	TNF-240MFMF	i00364	NCR	NCR

In addition to the above listed equipment standard RF connectors and cables were utilized in the testing of the described equipment. Prior to testing these components were tested to verify proper operation.

END OF TEST REPORT