

# WST-620v2 Flood and Freeze Sensor patent pending

## Installation Manual

### Specifications

Frequency:	433.92 MHz
Operating Temperature:	32° – 120°F (0° – 49°C)
Operating Humidity:	5 – 95% RH non condensing
Battery:	One 3Vdc lithium CR2450 (620mAH)
Battery life:	Up to 8 years

Detect Freeze at 41°F (5°C) restores at 45°F (7°C)  
 Detect a minimum of 1/64th in of water  
 Compatible with Honeywell receivers  
 Supervisory signal interval: 64 min(approx.)

### Package Contents

- 1x Flood and Freeze Sensor
- 1x Installation Manual
- 1x CR2450 Battery

### Optional Accessories (included in select kits)

- 1x External Sensor Adapter / Mounting Bracket
- 2x Mounting Screws
- 1x Water Detection Rope

### Component Identification

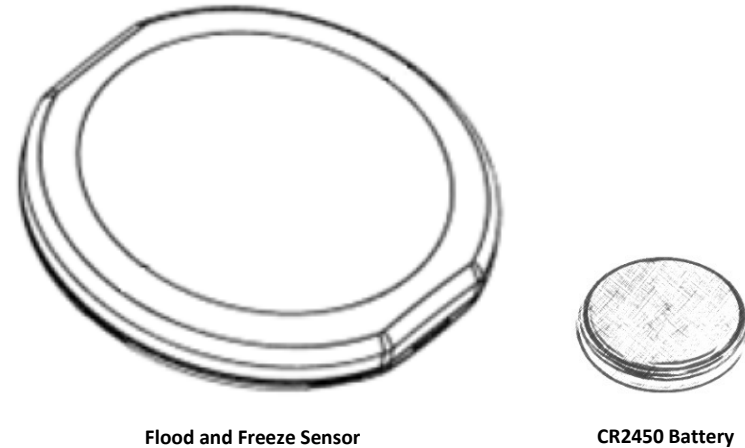

### Component Identification (Optional Accessories)

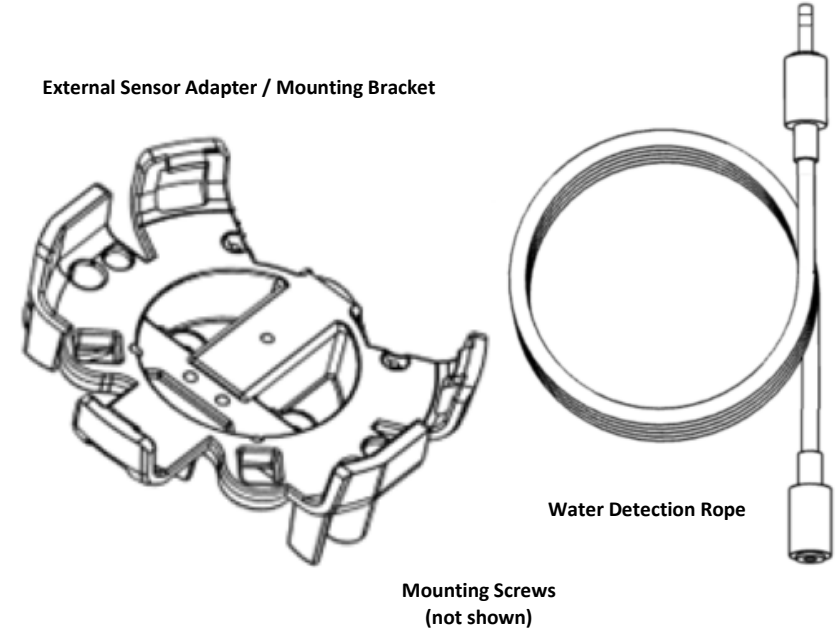

### OPERATION

The WST-620 sensor is designed to detect water across the gold probes and will alert immediately when present. The Freeze sensor will trigger when the temperature is below 41°F (5°C) and will send a restoral at 45°F (7°C).

### ENROLLING

To enroll the sensor, set your panel into sensor learn mode. Refer to your specific alarm panel instruction manual for details on these menus.

1. On the WST-620 locate the pry points on opposite edges of the sensor. Carefully use a plastic pry tool or standard slot head screwdriver to remove the top cover. (Tools not included)

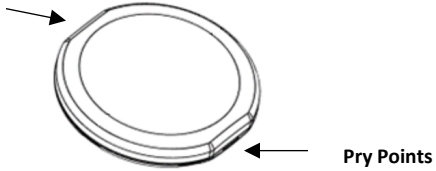

2. Insert the CR2450 battery with the (+) symbol facing up, if not already installed.

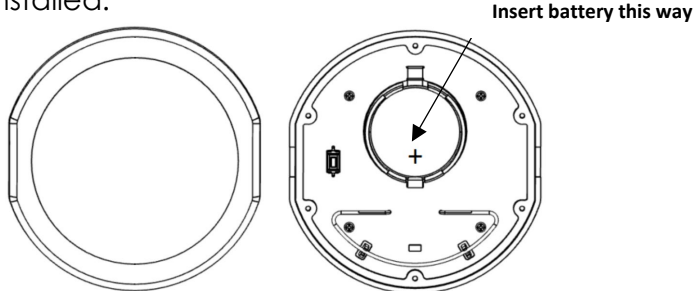

3. To learn in as a flood sensor, press and hold the Learn Button (SW1) for 1 - 2 seconds, then release. A single short on/off blink at 1 second confirms flood learn is initiated. The LED will remain solid ON during the learn transmission. The Flood sensor function enrolls as Loop 1 of the Flood S/N. Repeat as required.

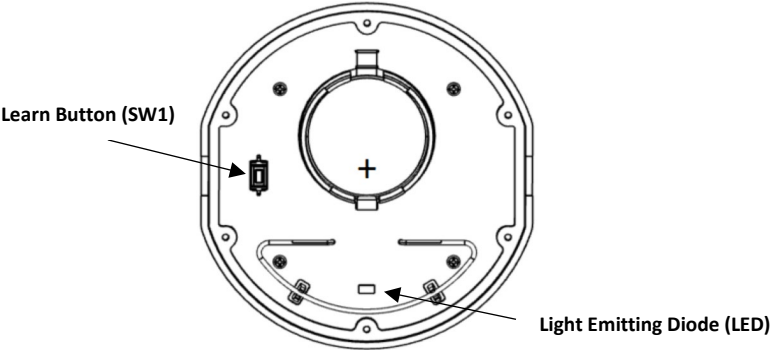

4. To learn in as a freeze sensor, press and hold the Learn Button (SW1) for 2 - 3 seconds, then release. A single short on/off blink at 1 second plus a double on/off blink at 2 seconds confirms freeze learn is initiated. The LED will remain solid ON during the learn transmission. The Freeze sensor function enrolls as Loop 1 of the Freeze S/N. Repeat as required.

5. After successful enrollment, verify the gasket in the top cover is properly seated, then snap the top cover onto the bottom cover aligning the flat sides. Inspect the seam all the way around the edge of the device to ensure it is completely sealed.

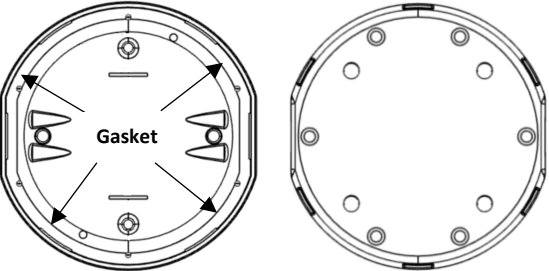

Note: Alternately, the 7 digit serial numbers printed on the back of each unit can be manually entered into the panel. For 2GIG systems the equipment code is "0637"

### Testing the Unit

After successful enrollment, a test transmission sending current states can be initiated by pressing and immediately releasing the Learn Button (SW1), with the top cover open. The LED will remain solid ON during the button-initiated test transmission. With the unit fully assembled and sealed, placing wet fingers on any two probes will trigger a flood transmission. Note the LED will not illuminate for a wet flood test and remains OFF during all normal operation.

### PLACEMENT

Place the flood detector anywhere that you wish to detect a flood or freezing temperature, such as under a sink, in or near a hot water heater, a basement or behind a washing machine. As a best practice send a test transmission from the desired placement location to ensure the panel can receive it.

## USING OPTIONAL ACCESSORIES

The optional accessories enhance the Flood and Freeze Sensor installation by allowing additional installation locations, mounting on vertical surfaces such as walls or cabinet interiors with the External Sensor Adapter / Mounting Bracket and included screws. The Water Detection Rope can be routed down and across the floor covering a larger detection area. The length of the Water Detection Rope jacket is the detection area.

### Setup

1. Be sure to complete all enrollment steps before installing optional accessories.
2. Plug the Water Detection Rope into the socket located on the end of the External Sensor Adapter / Mounting Bracket.
3. Wrap the Water Detection Rope around the strain relief / retension posts on the back of the External Sensor Adapter / Mounting Bracket to prevent the rope from being inadvertently unplugged.
4. Use screws to secure the External Sensor Adapter / Mounting Bracket, if desired.
5. Align the flat sides of the Flood and Freeze Sensor with the sides of the External Sensor Adapter / Mounting Bracket. Then snap the sensor into the bracket ensuring the sensor is fully seated and the three retention tabs are fully engaged.
6. Route the length of the Water Detection Rope across the horizontal surface(s) to be monitored for water.

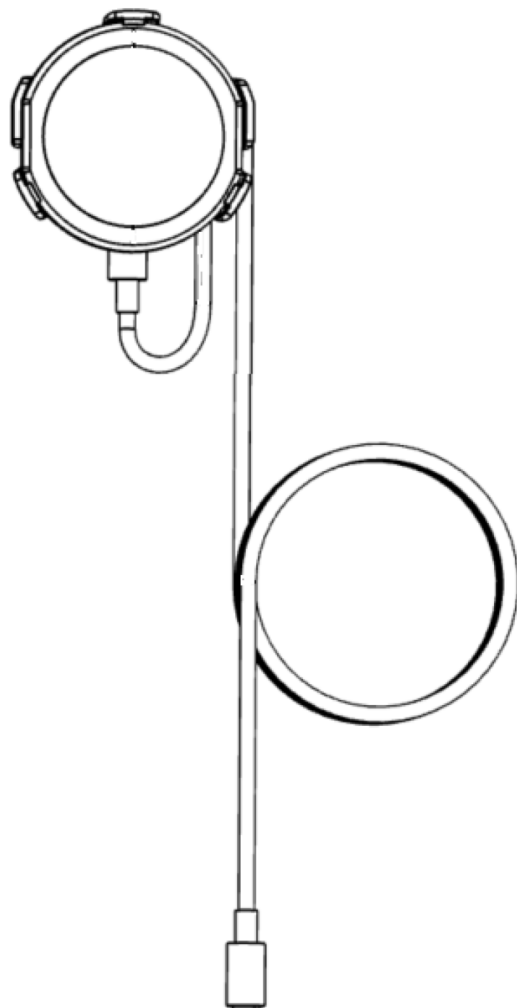

### Notes:

- Up to ten (10) Water Detection Rope sensors can be chained together to further extend the detection area(s).
- **Once water detection occurs using the Water Detection Rope, it may take several hours for the rope to sufficiently dry and a restore signal to be sent.** Adequate ventilation will speed the drying process.
- Improper connections between the WST-620 Flood and Freeze Sensor, the External Sensor Adapter / Mounting Bracket, and the Water Detection Rope can prevent flood detection, or cause false flood restore. Always verify connections are secure.

## REPLACING THE BATTERY

When the battery is low a signal will be sent to the control panel. To replace the battery:

1. On the WST-620 locate the pry points on opposite edges of the sensor, carefully use a plastic pry tool or standard slot head screwdriver to remove the top cover. (Tools not included)
2. Carefully remove the old battery.
3. Insert the new CR2450 battery with the (+) symbol facing up.
4. Verify the gasket in the top cover is properly seated, then snap the top cover onto the bottom cover, aligning the flat sides. Inspect the seam all the way around the edge of the device to ensure it is completely sealed.

## FCC COMPLIANCE STATEMENT

This equipment has been tested and found to comply with the limits for Class B digital devices, pursuant to Part 15 of the FCC Rules.

Operation is subject to the following two conditions:

- (1) This device may not cause harmful interference and
  - (2) this device must accept any interference received, including interference that may cause undesired operation. These limits are designed to provide reasonable protection against harmful interference in a residential installation. This equipment generates uses and can radiate radio frequency energy and, if not installed and used in accordance with the instruction manual, may cause harmful interference to radio communications. However, there is no guarantee that interference will not occur in a particular installation. If this equipment does cause harmful interference to radio or television reception, which can be determined by turning the equipment off and on, the user is encouraged to try to correct the interference by one or more of the following measures:
- Re-orient or relocate the receiving antenna
  - Increase the separation between the equipment and receiver
  - Connect the equipment to an outlet on a different circuit from the receiver
  - Consult the dealer or an experienced radio/TV contractor for help.

Warning: Changes or modifications not expressly approved by Ecolink Intelligent Technology Inc. could void the user's authority to operate the equipment. This device complies with Industry Canada licence-exempt RSS standard(s). Operation is subject to the following two conditions:

- (1) this device may not cause interference, and
- (2) this device must accept any interference, including interference that may cause undesired operation of the device.

Cet appareil est conforme la norme d'Industrie Canada exempts de licence RSS. Son fonctionnement est soumis aux deux conditions suivantes:

- (1) cet appareil ne peut pas provoquer d'interférences, et
- (2) cet appareil doit accepter toute interférence, y compris les interférences qui peuvent causer un mauvais fonctionnement de la dispositif.

FCC ID: XQC-WST620V2

IC: 9863B-WST620V2

## WARRANTY

Ecolink Intelligent Technology Inc. warrants that for a period of 5 years from the date of purchase that this product is free from defects in material and workmanship. This warranty does not apply to damage caused by shipping or handling, or damage caused by accident, abuse, misuse, misapplication, ordinary wear, improper maintenance, failure to follow instructions or as a result of any unauthorized modifications. If there is a defect in materials and workmanship under normal use within the warranty period Ecolink Intelligent Technology Inc. shall, at its option, repair or replace the defective equipment upon return of the equipment to the original point of purchase. The foregoing warranty shall apply only to the original buyer, and is and shall be in lieu of any and all other warranties, whether expressed or implied and of all other obligations or liabilities on the part of Ecolink Intelligent Technology Inc. neither assumes responsibility for, nor authorizes any other person purporting to act on its behalf to modify or to change this warranty.

The maximum liability for Ecolink Intelligent Technology Inc. under all circumstances for any warranty issue shall be limited to a replacement of the defective product. It is recommended that the customer check their equipment on a regular basis for proper operation.

© 2023 Ecolink Intelligent Technology Inc.



Ecolink Intelligent Technology Inc.  
2055 Corte Del Nogal  
Carlsbad CA 92011  
855-632-6546

PN WST-620V2 R2.00  
REV DATE:  
05/03/2023  
patent pending