

High Channel:

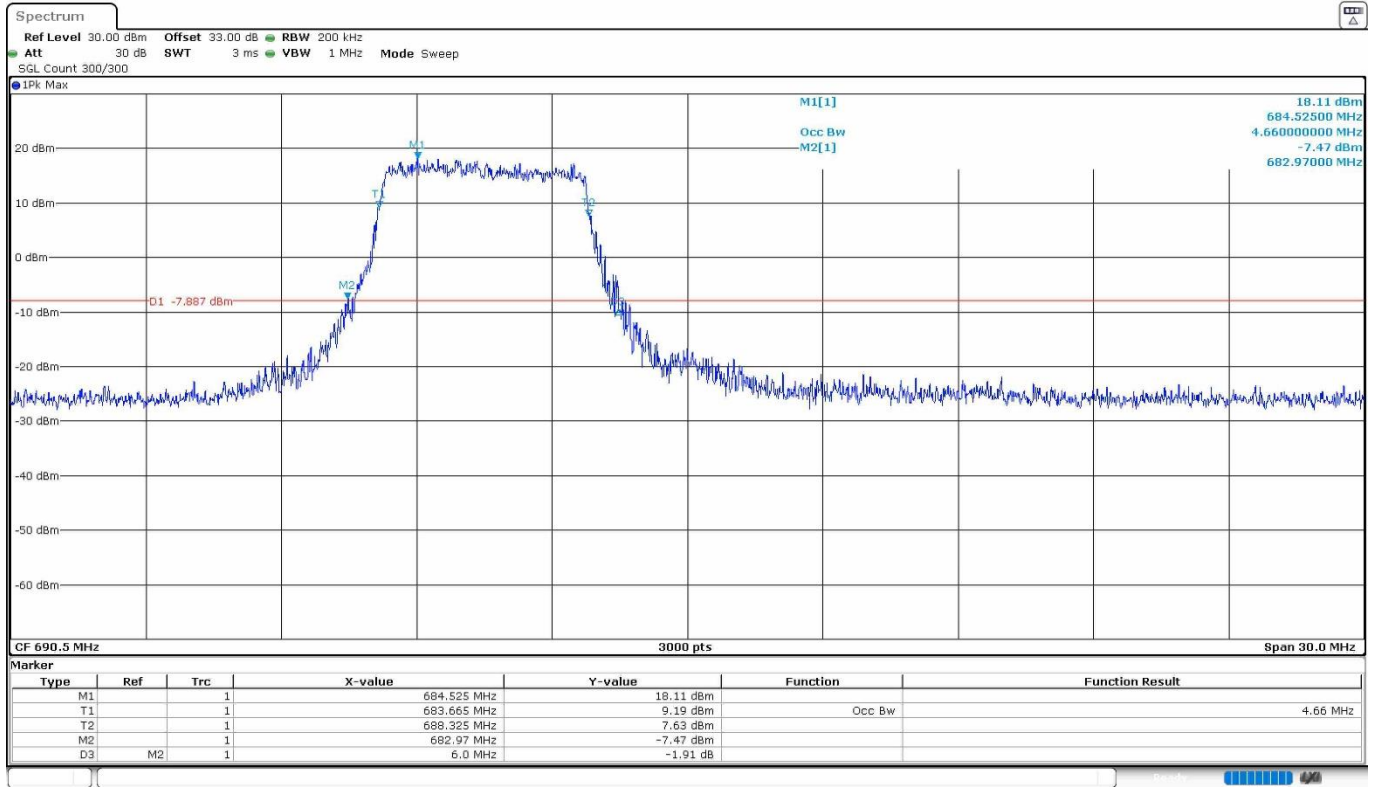

Date: 18.05.2023 05:55:19

LTE Cat 1bis Band 71. BW=20 MHz. QPSK. RB Size All.

Low Channel:

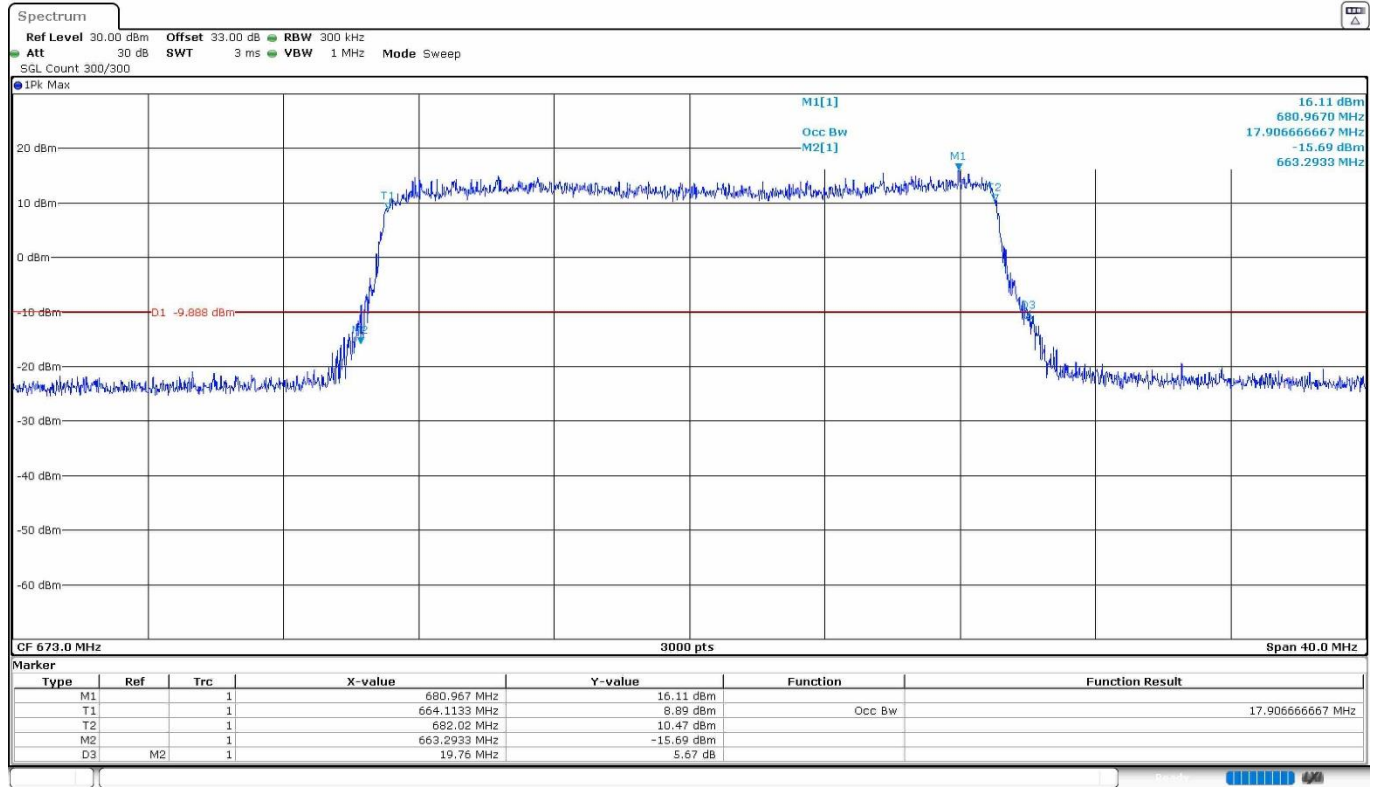

Date: 18.05.2023 05:36:25

Middle Channel:

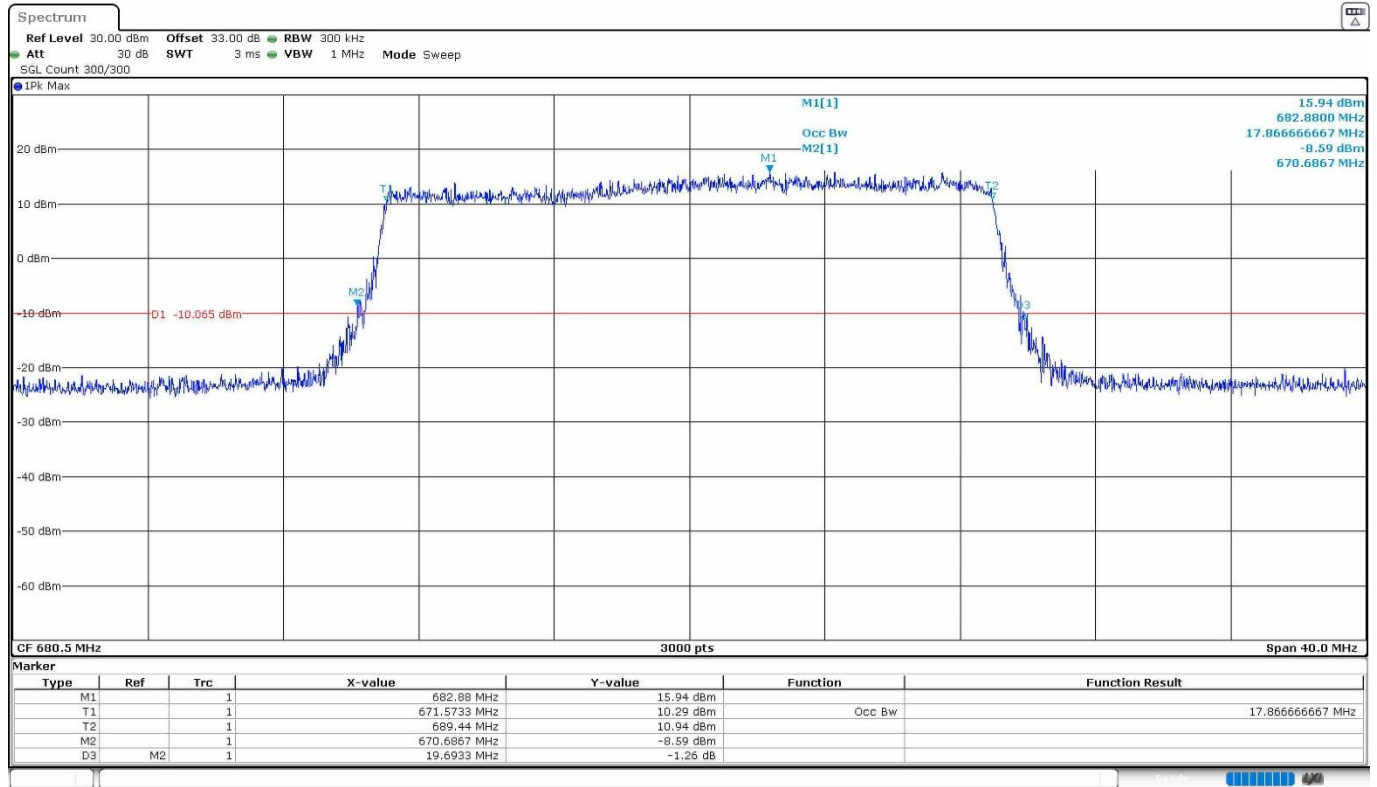

Date: 18.05.2023 05:37:23

High Channel:

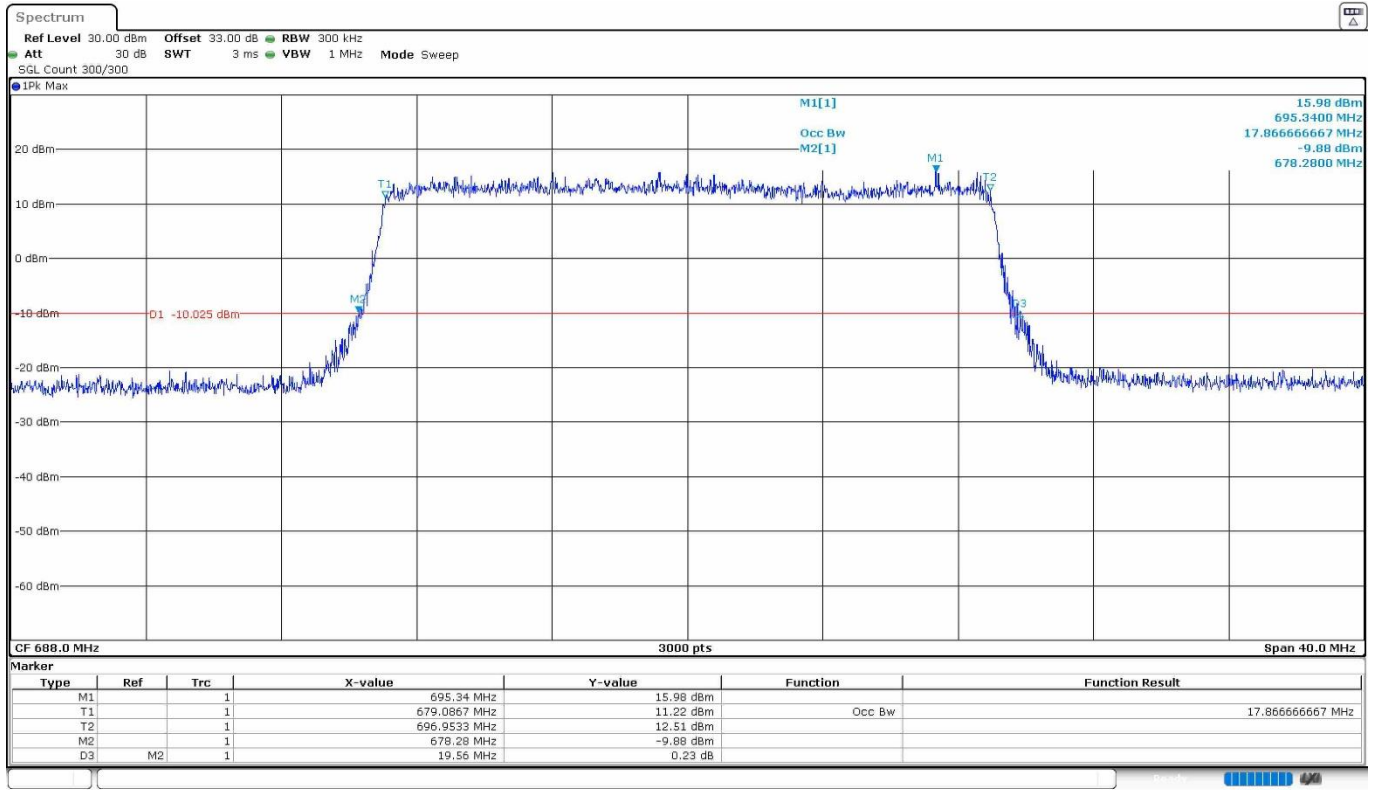

Date: 18.05.2023 05:38:20

LTE Cat 1bis Band 71. BW=20 MHz. 16QAM. RB Size All.
 Low Channel:

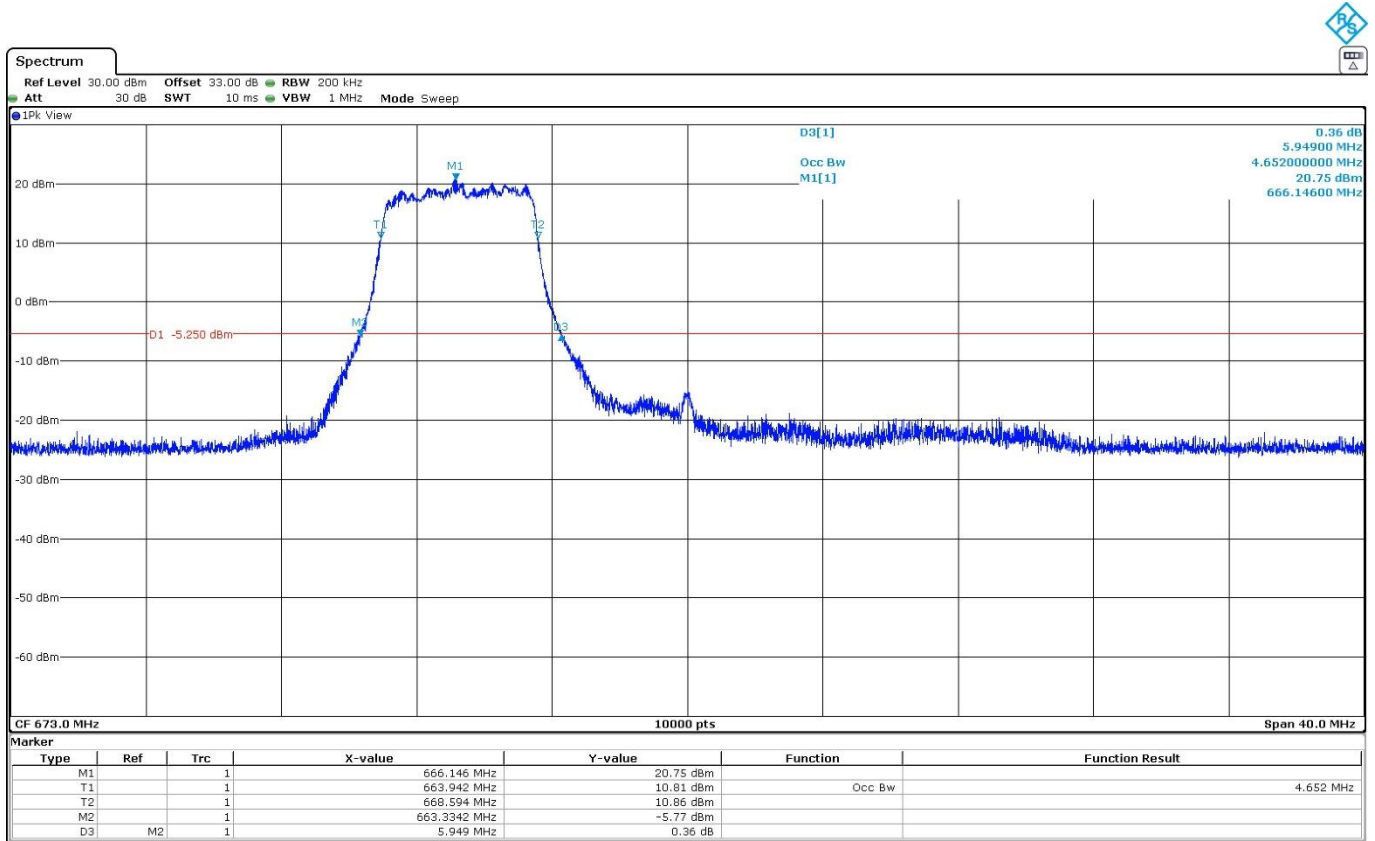

Middle Channel:

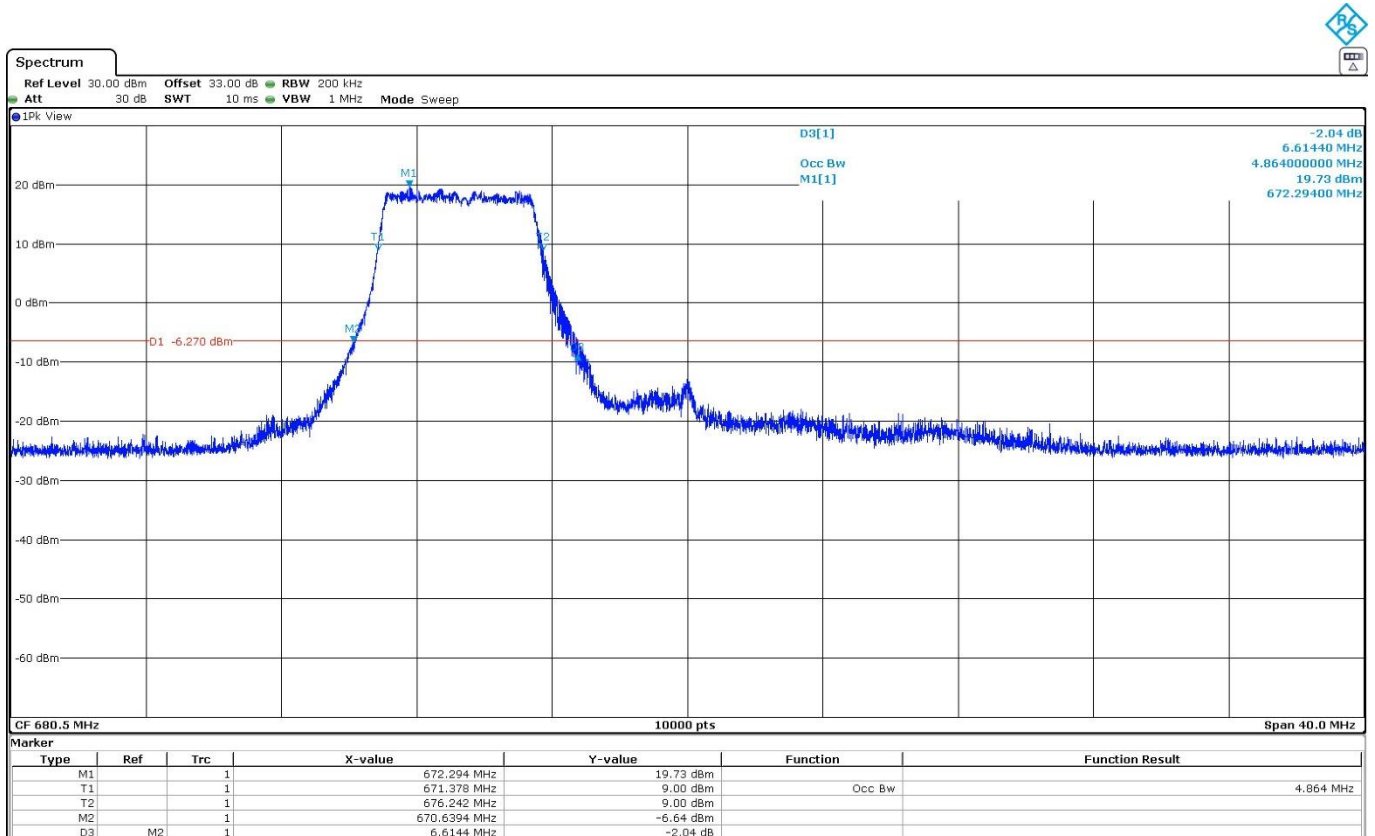

High Channel:

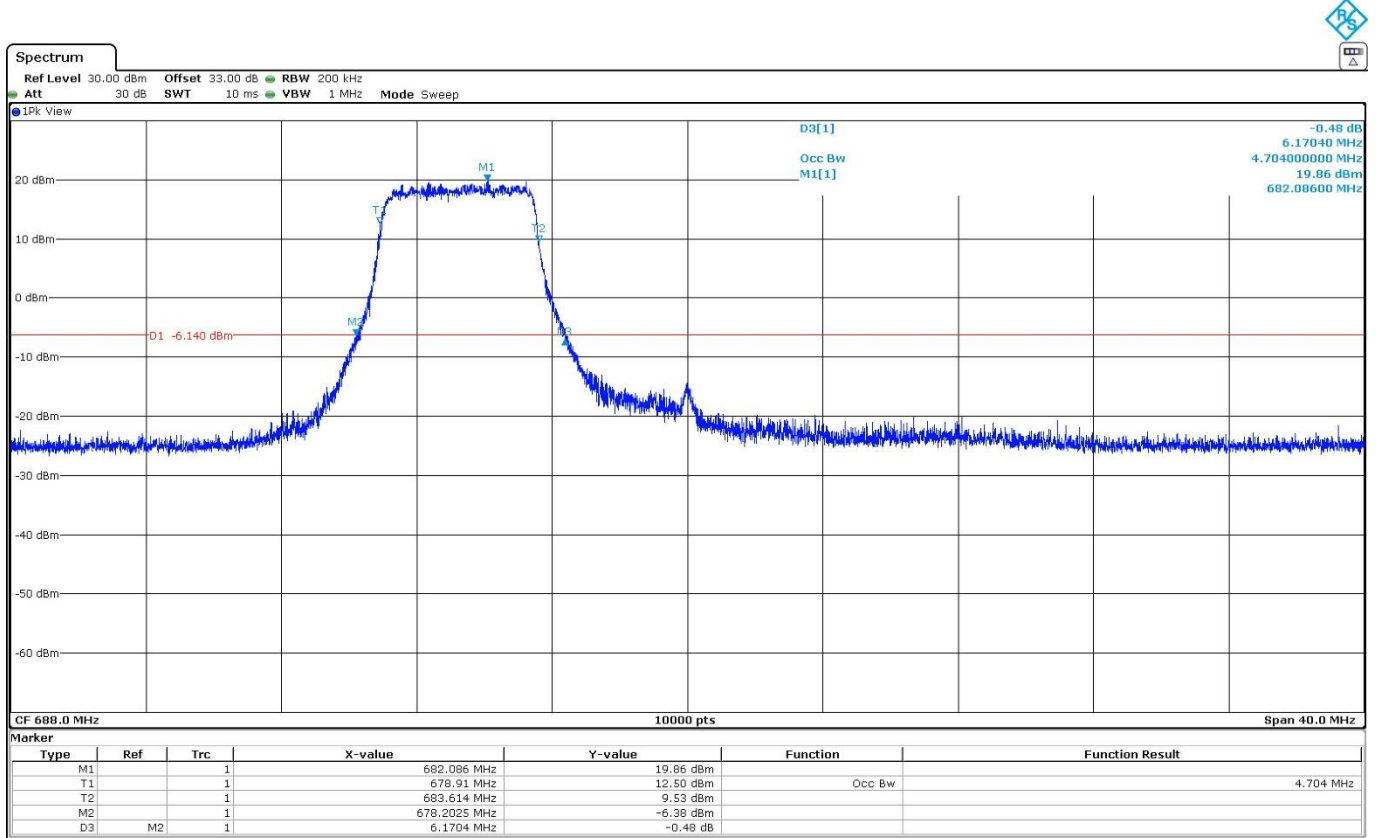

Spurious Emissions at Antenna Terminals

Limits

1. LTE Cat 1bis Band 12.

* FCC §27.53 (g):

(g) For operations in the 600 MHz band and the 698–746 MHz band, the power of any emission outside a licensee's frequency band(s) of operation shall be attenuated below the transmitter power (P) within the licensed band(s) of operation, measured in watts, by at least $43 + 10 \log(P)$ dB. Compliance with this provision is based on the use of measurement instrumentation employing a resolution bandwidth of 100 kilohertz or greater. However, in the 100 kilohertz bands immediately outside and adjacent to a licensee's frequency block, a resolution bandwidth of at least 30 kHz may be employed.

* RSS-130, 4.7:

4.7.1 General unwanted emissions limits:

The unwanted emissions in any 100 kHz bandwidth on any frequency outside the low frequency edge and the high frequency edge of each frequency block range(s), shall be attenuated below the transmitter power, P (dBW), by at least $43 + 10 \log_{10} p$ (watts), dB. However, in the 100 kHz band immediately outside of the equipment's frequency block range, a resolution bandwidth of 30 kHz may be employed.

2. LTE Cat 1bis Band 13.

* FCC §27.53 (c):

(c) For operations in the 746-758 MHz band and the 776-788 MHz band, the power of any emission outside the licensee's frequency band(s) of operation shall be attenuated below the transmitter power (P) within the licensed band(s) of operation, measured in watts, in accordance with the following:

(1) On any frequency outside the 746–758 MHz band, the power of any emission shall be attenuated outside the band below the transmitter power (P) by at least $43 + 10 \log(P)$ dB;

(2) On any frequency outside the 776-788 MHz band, the power of any emission shall be attenuated outside the band below the transmitter power (P) by at least $43 + 10 \log(P)$ dB;

(3) On all frequencies between 763–775 MHz and 793–805 MHz, by a factor not less than $76 + 10 \log(P)$ dB in a 6.25 kHz band segment, for base and fixed stations;

(4) On all frequencies between 763–775 MHz and 793–805 MHz, by a factor not less than $65 + 10 \log(P)$ dB in a 6.25 kHz band segment, for mobile and portable stations;

(5) Compliance with the provisions of paragraphs (c)(1) and (c)(2) of this section is based on the use of measurement instrumentation employing a resolution bandwidth of 100 kHz or greater. However, in the 100 kHz bands immediately outside and adjacent to the frequency block, a resolution bandwidth of at least 30 kHz may be employed;

(6) Compliance with the provisions of paragraphs (c)(3) and (c)(4) of this section is based on the use of measurement instrumentation such that the reading taken with any resolution bandwidth setting should be adjusted to indicate spectral energy in a 6.25 kHz segment.

* RSS-130, 4.7:

4.7.1 General unwanted emissions limits:

The unwanted emissions in any 100 kHz bandwidth on any frequency outside the low frequency edge and the high frequency edge of each frequency block range(s), shall be attenuated below the transmitter power,

P (dBW), by at least $43 + 10 \log_{10} p$ (watts), dB. However, in the 100 kHz band immediately outside of the equipment's frequency block range, a resolution bandwidth of 30 kHz may be employed.

4.7.2 Additional unwanted emissions limits:

In addition to the limit outlined in section 4.7.1 above, equipment operating in the frequency bands 746-756 MHz and 777-787 MHz shall also comply with the following restrictions:

- a. the power of any unwanted emissions in any 6.25 kHz bandwidth for all frequencies between 763-775 MHz and 793-806 MHz shall be attenuated below the transmitter power, P (dBW), by at least:
 - i. $76 + 10 \log_{10} p$ (watts), dB, for base and fixed equipment and
 - ii. $65 + 10 \log_{10} p$ (watts), dB, for mobile and portable equipment
- b. the e.i.r.p. in the band 1559-1610 MHz shall not exceed -70 dBW/MHz for wideband signal and -80 dBW for discrete emission with bandwidth less than 700 Hz.

3. LTE Cat 1bis Bands 4, 66.

* FCC §27.53 (h):

AWS emission limits:

(1) General protection levels. Except as otherwise specified below, for operations in the 1695–1710 MHz, 1710–1755 MHz, 1755–1780 MHz, 1915–1920 MHz, 1995–2000 MHz, 2000–2020 MHz, 2110–2155 MHz, 2155–2180 MHz, and 2180–2200 bands, the power of any emission outside a licensee's frequency block shall be attenuated below the transmitter power (P) in watts by at least $43 + 10 \log_{10} (P)$ dB.

(3) Measurement procedure.

(i) Compliance with this provision is based on the use of measurement instrumentation employing a resolution bandwidth of 1 megahertz or greater. However, in the 1 megahertz bands immediately outside and adjacent to the licensee's frequency block, a resolution bandwidth of at least one percent of the emission bandwidth of the fundamental emission of the transmitter may be employed. The emission bandwidth is defined as the width of the signal between two points, one below the carrier center frequency and one above the carrier center frequency, outside of which all emissions are attenuated at least 26 dB below the transmitter power.

(ii) When measuring the emission limits, the nominal carrier frequency shall be adjusted as close to the licensee's frequency block edges, both upper and lower, as the design permits.

(iii) The measurements of emission power can be expressed in peak or average values, provided they are expressed in the same parameters as the transmitter power.

* RSS-139, 5.6:

Unwanted emissions shall be measured in terms of average value. Equipment shall have the TRP or conducted power (all antenna connectors), of unwanted emissions outside the frequency block or frequency block group not exceeding the limits shown in the next table:

Offset from the edge of the frequency block or frequency block group	Unwanted emission limits
≤ 1 MHz	-13 dBm/(1% of OB)
> 1 MHz	-13 dBm/MHz

Where OB is the occupied bandwidth.

At P_o transmitting power, the specified minimum attenuation becomes $43 + 10 \log (P_o)$, and the level in dBm relative to P_o becomes:

$$P_o \text{ (dBm)} - [43 + 10 \log (P_o \text{ in mW}) - 30] = -13 \text{ dBm}$$

At P_o transmitting power, the specified minimum attenuation becomes $65+10 \log (P_o)$, and the level in dBm relative to P_o becomes:

$$P_o \text{ (dBm)} - [65 + 10 \log (P_o \text{ in mW}) - 30] = -35 \text{ dBm}$$

4. LTE Cat 1bis Band 71.

* FCC §27.53 (g):

(g) For operations in the 600 MHz band and the 698–746 MHz band, the power of any emission outside a licensee's frequency band(s) of operation shall be attenuated below the transmitter power (P) within the licensed band(s) of operation, measured in watts, by at least $43 + 10 \log (P)$ dB. Compliance with this provision is based on the use of measurement instrumentation employing a resolution bandwidth of 100 kilohertz or greater. However, in the 100 kilohertz bands immediately outside and adjacent to a licensee's frequency block, a resolution bandwidth of at least 30 kHz may be employed.

* RSS-130, 4.7:

4.7.1 General unwanted emissions limits:

The unwanted emissions in any 100 kHz bandwidth on any frequency outside the low frequency edge and the high frequency edge of each frequency block range(s), shall be attenuated below the transmitter power, P (dBW), by at least $43 + 10 \log_{10} p$ (watts), dB. However, in the 100 kHz band immediately outside of the equipment's frequency block range, a resolution bandwidth of 30 kHz may be employed.

Method

The EUT RF output connector was connected to a spectrum analyser and to the Universal Radio Communication tester R&S CMW500 (selecting maximum transmission power of the EUT and different modes of modulation) using a 50-Ohm attenuator and a power divider.

The reading of the spectrum analyser is corrected with the attenuation loss of connection between output terminal of EUT and input of the spectrum analyser.

The configuration of Resource Blocks and modulation which is the worst case for conducted power was used.

Test Setup

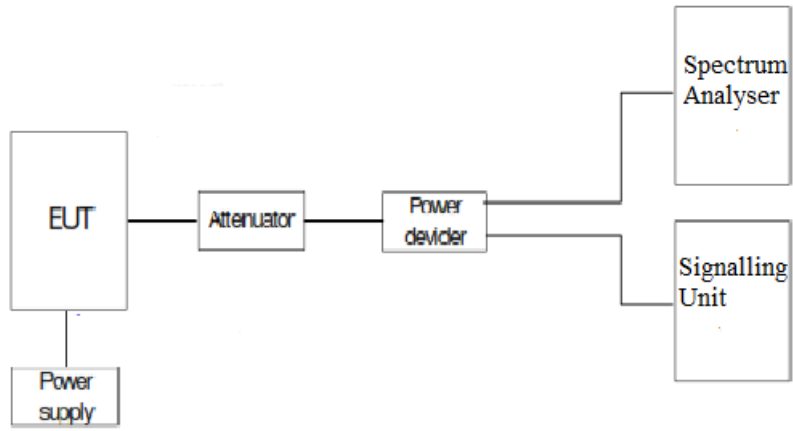

Results

LTE Cat 1bis Band 12: BW=1.4 MHz. QPSK. RB Size=1, RB Offset=0.

- Low Channel: No spurious frequencies at less than 20 dB below the limit.
- Middle Channel: No spurious frequencies at less than 20 dB below the limit.
- High Channel: No spurious frequencies at less than 20 dB below the limit

LTE Cat 1bis Band 13: BW=5 MHz. QPSK. RB Size 1. RB Offset 0.

- Low Channel: No spurious frequencies at less than 20 dB below the limit.
- High Channel: No spurious frequencies at less than 20 dB below the limit.

LTE Cat 1bis Band 66: BW=20 MHz. QPSK. RB Size 1. RB Offset 0.

- Low Channel: No spurious frequencies at less than 20 dB below the limit.
- Middle Channel: Spurious frequencies at less than 20 dB below the limit:

Frequency (MHz)	Emission limitations conducted (dBm)
5208.0625	-27.19

- High Channel: No spurious frequencies at less than 20 dB below the limit.

LTE Cat 1bis Band 71: BW=15 MHz. QPSK. RB Size=1. RB Offset=0.

- Low Channel: No spurious frequencies at less than 20 dB below the limit.
- Middle Channel: No spurious frequencies at less than 20 dB below the limit.
- High Channel: No spurious frequencies at less than 20 dB below the limit.

Measurement uncertainty (dB): $<\pm 2.76$

Verdict

PASS

LTE Cat 1bis Band 12. BW=1.4 MHz. QPSK. RB Size 1. RB Offset 0.

Subrange	Step Size	Detectors	Bandwidth	Sweep Time	Preamp
Receiver: [FSV 40]					
9 kHz - 150 kHz	14,1 Hz	PK+	300 Hz	Coupled	0 dB
150 kHz - 30 MHz	932,812 Hz	PK+	10 kHz	Coupled	0 dB
30 MHz - 1 GHz	30,312 kHz	PK+	100 kHz	Coupled	0 dB
1 GHz - 2 GHz	31,25 kHz	PK+	100 kHz	Coupled	0 dB
2 GHz - 3 GHz	31,25 kHz	PK+	100 kHz	Coupled	0 dB
3 GHz - 4 GHz	31,25 kHz	PK+	100 kHz	Coupled	0 dB
4 GHz - 5 GHz	31,25 kHz	PK+	100 kHz	Coupled	0 dB
5 GHz - 6 GHz	31,25 kHz	PK+	100 kHz	Coupled	0 dB
6 GHz - 7 GHz	31,25 kHz	PK+	100 kHz	Coupled	0 dB
7 GHz - 8 GHz	31,25 kHz	PK+	100 kHz	Coupled	0 dB

Low Channel:

Full Spectrum

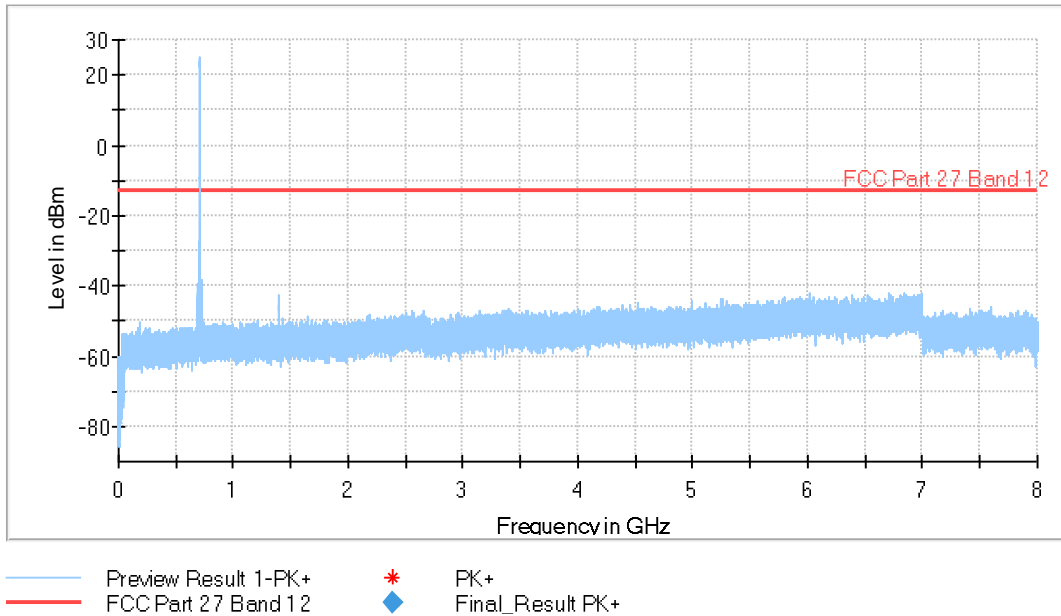

The peak above the limit is the carrier frequency.
 The highest peak next to the carrier is the Downlink frequency.

Middle Channel:

Full Spectrum

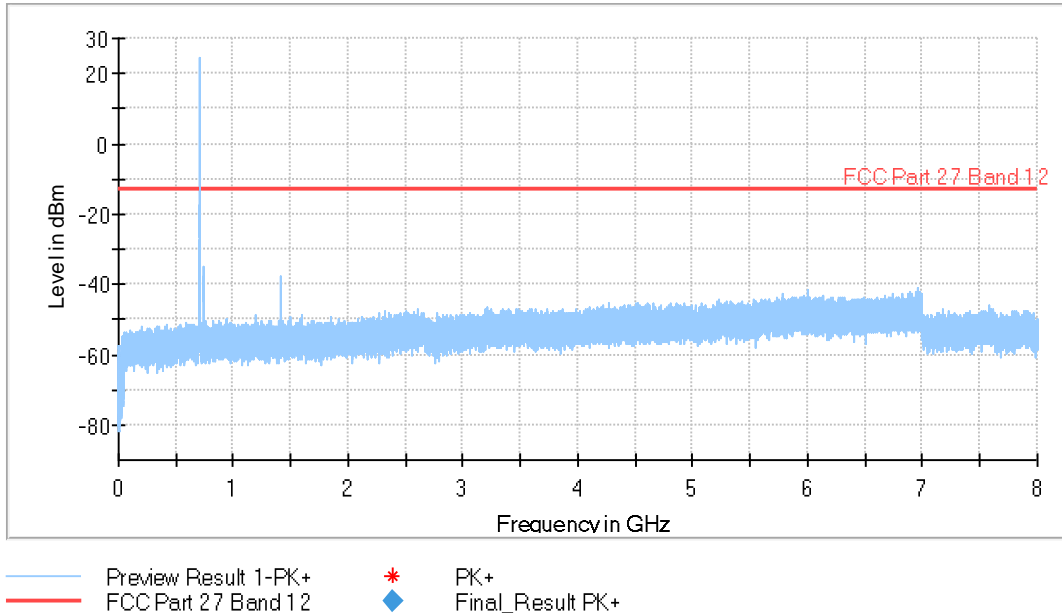

The peak above the limit is the carrier frequency.
 The highest peak next to the carrier is the Downlink frequency.

High Channel:

Full Spectrum

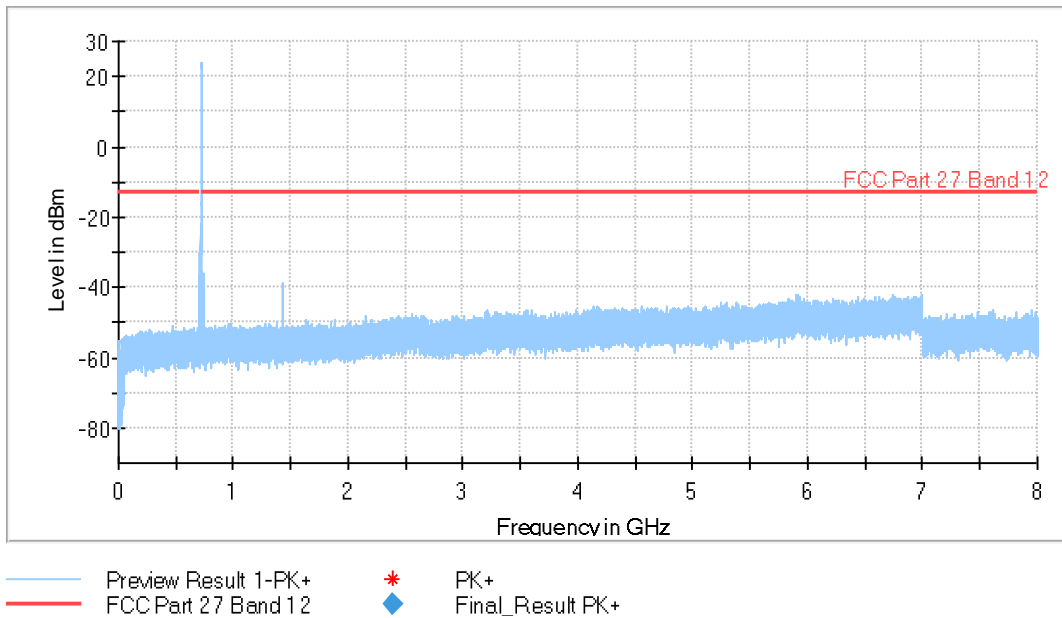

The peak above the limit is the carrier frequency.
 The highest peak next to the carrier is the Downlink frequency.

LTE Cat 1bis Band 13. BW=5 MHz. QPSK. RB Size 1. RB Offset 0.

Subrange	Step Size	Detectors	Bandwidth	Sweep Time	Preamp
Receiver: [FSV 40]					
9 kHz - 150 kHz	14,1 Hz	PK+	300 Hz	Coupled	0 dB
150 kHz - 30 MHz	932,812 Hz	PK+	10 kHz	Coupled	0 dB
30 MHz - 1 GHz	30,312 kHz	PK+	100 kHz	Coupled	0 dB
763 MHz - 775 MHz	6.25 kHz	PK+	20 kHz	Coupled	0 dB
793 MHz - 806 MHz	6.25 kHz	PK+	20 kHz	Coupled	0 dB
1 GHz - 2 GHz	31,25 kHz	PK+	100 kHz	Coupled	0 dB
2 GHz - 3 GHz	31,25 kHz	PK+	100 kHz	Coupled	0 dB
3 GHz - 4 GHz	31,25 kHz	PK+	100 kHz	Coupled	0 dB
4 GHz - 5 GHz	31,25 kHz	PK+	100 kHz	Coupled	0 dB
5 GHz - 6 GHz	31,25 kHz	PK+	100 kHz	Coupled	0 dB
6 GHz - 7 GHz	31,25 kHz	PK+	100 kHz	Coupled	0 dB
7 GHz - 8 GHz	31,25 kHz	PK+	100 kHz	Coupled	0 dB

Low Channel:

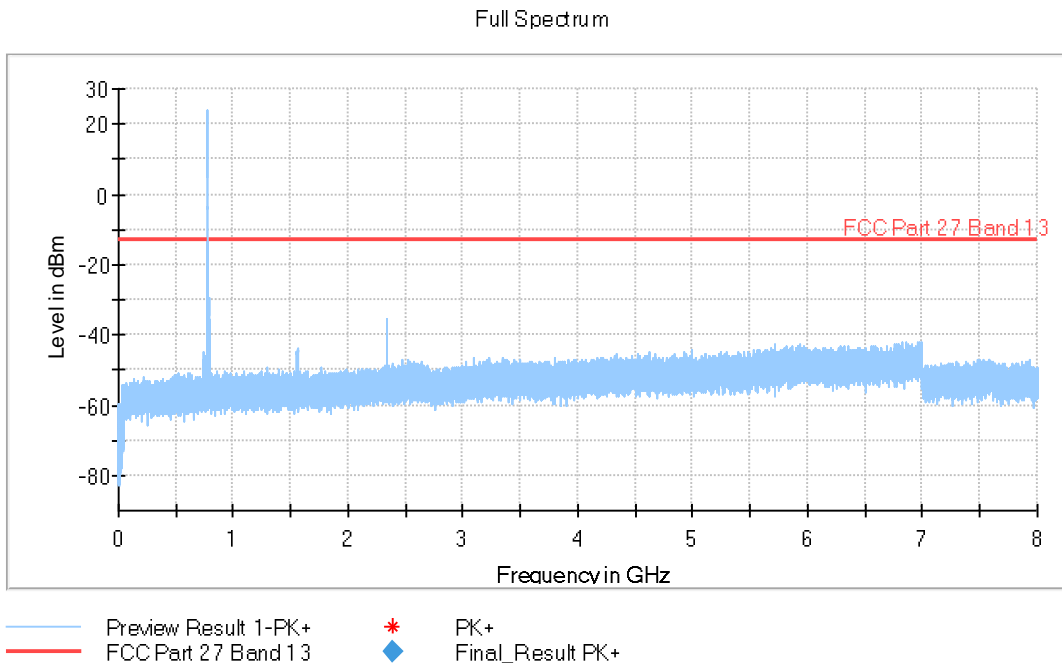

The peak above the limit is the carrier frequency.

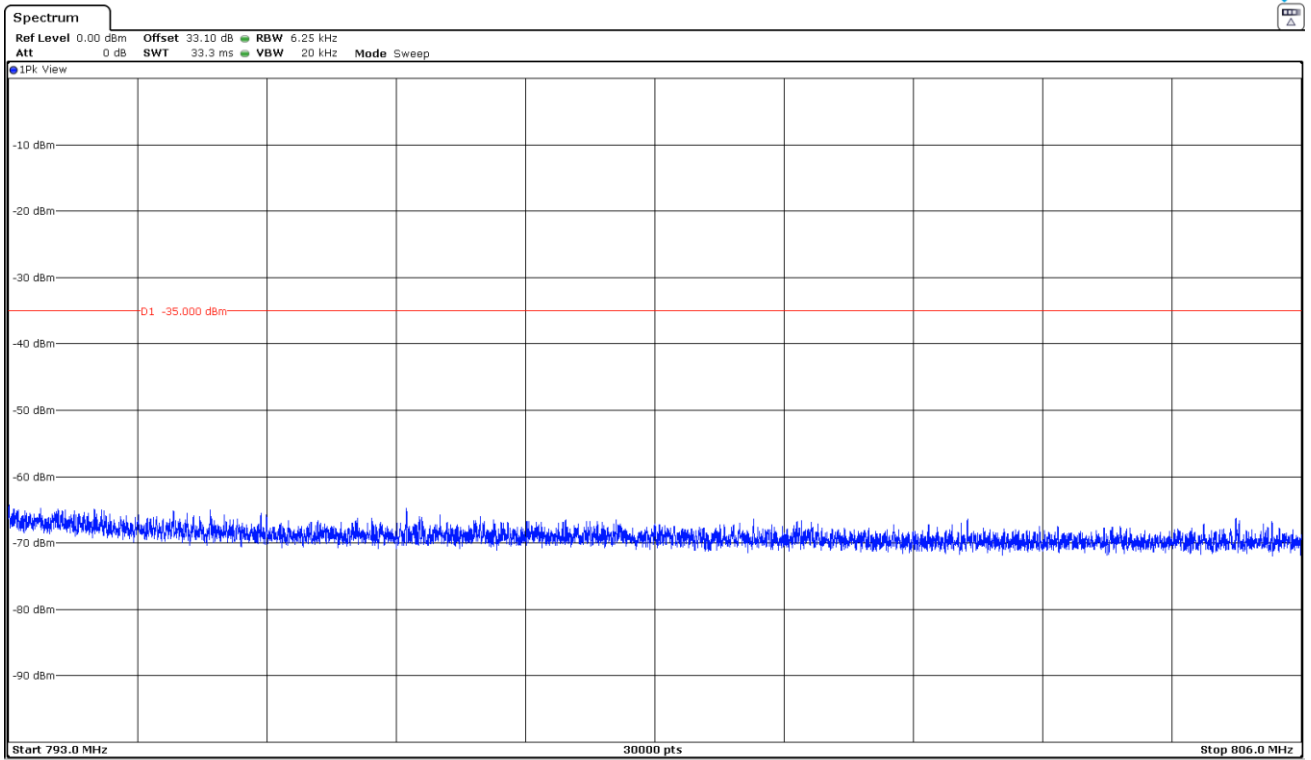
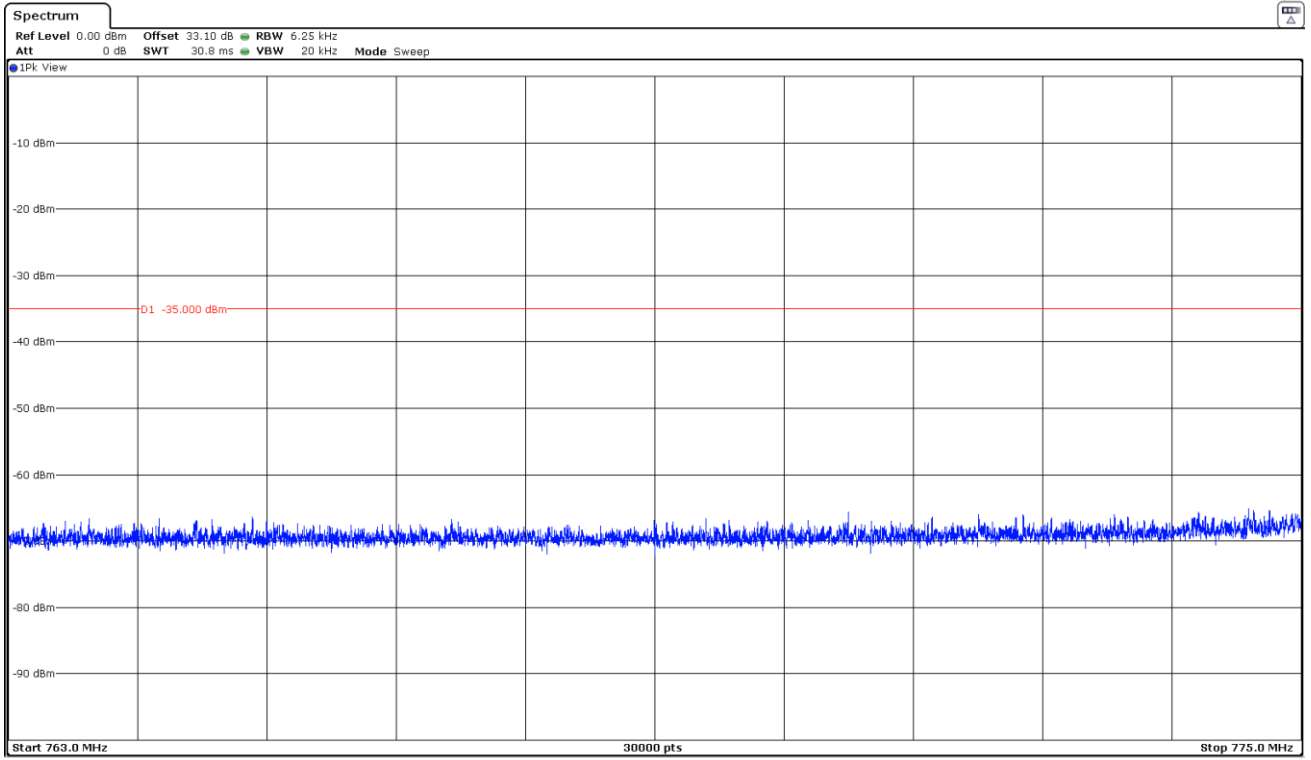

High Channel:

Full Spectrum

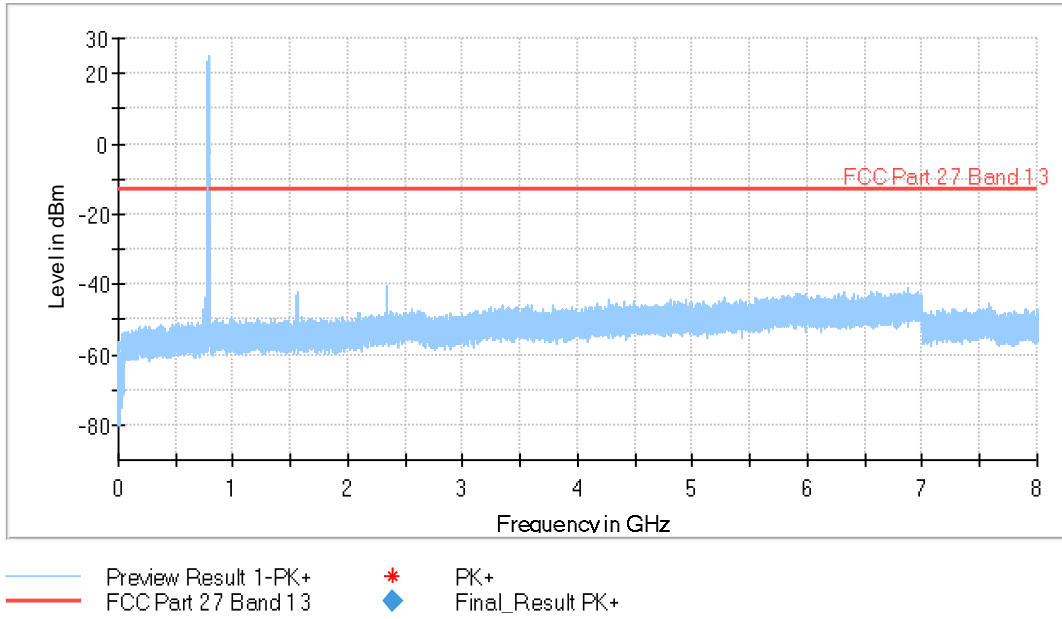

The peak above the limit is the carrier frequency.

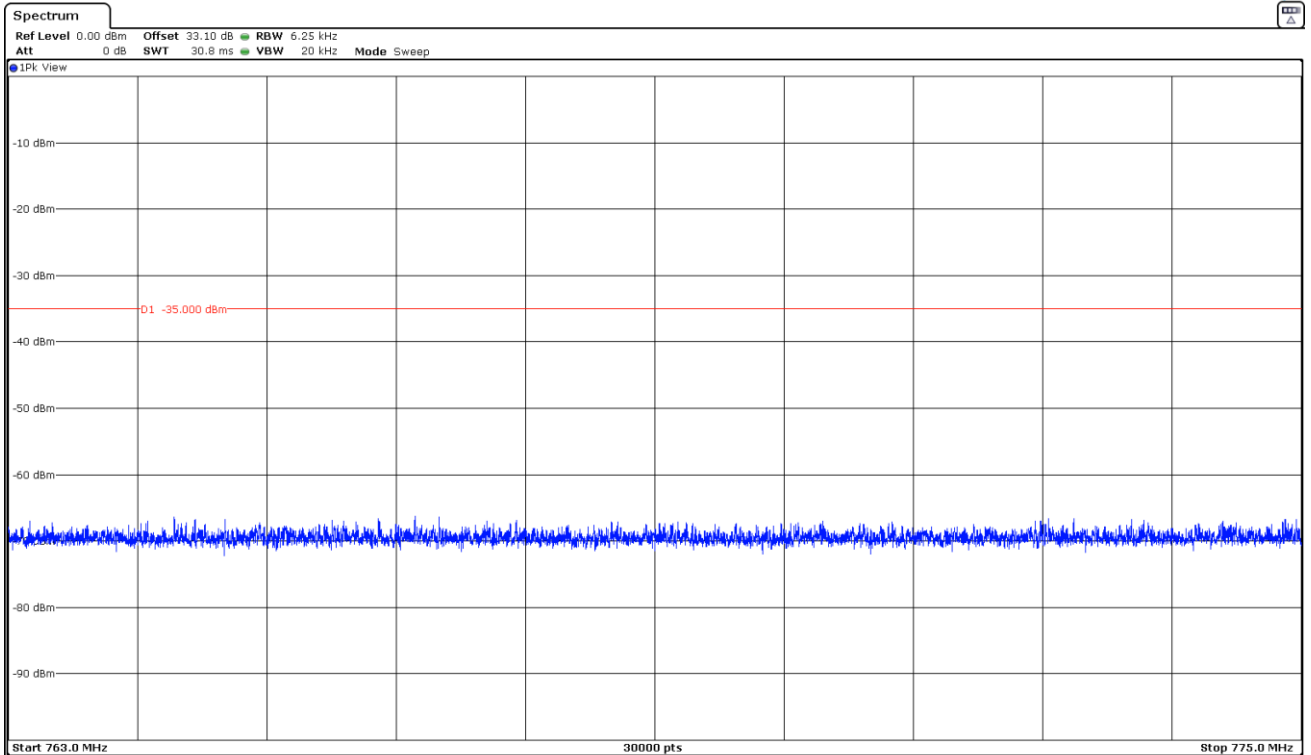

Date: 22.DEC.2023 05:58:38

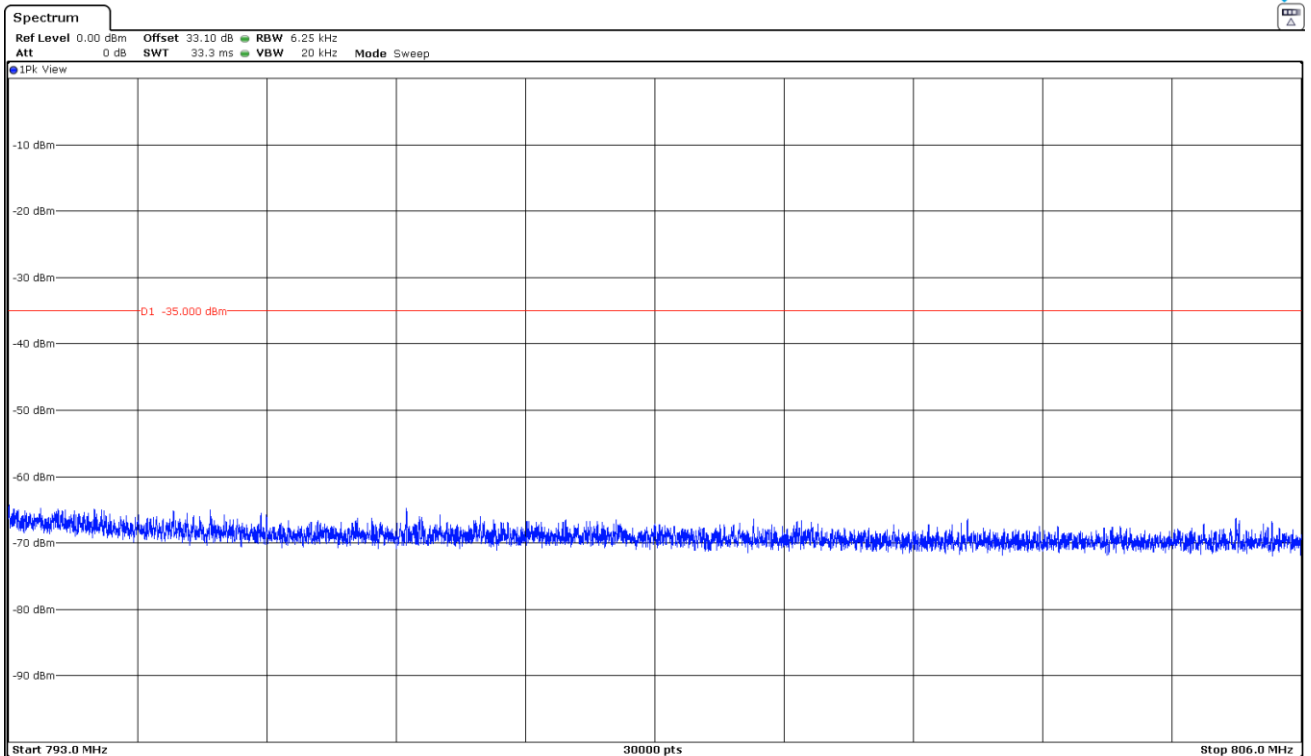

Date: 22.DEC.2023 06:00:09

LTE Cat 1bis Band 66. BW=20 MHz. QPSK. RB Size 1. RB Offset 0.

Subrange	Step Size	Detectors	Bandwidth	Sweep Time	Preamp
Receiver: [FSV 40]					
9 kHz - 150 kHz	14,1 Hz	PK+	300 Hz	Coupled	0 dB
150 kHz - 30 MHz	932,812 Hz	PK+	10 kHz	Coupled	0 dB
30 MHz - 1 GHz	303,125 kHz	PK+	1 MHz	Coupled	0 dB
1 GHz - 10 GHz	281,25 kHz	PK+	1 MHz	Coupled	0 dB
10 GHz - 18 GHz	250 kHz	PK+	1 MHz	Coupled	0 dB

Low Channel:

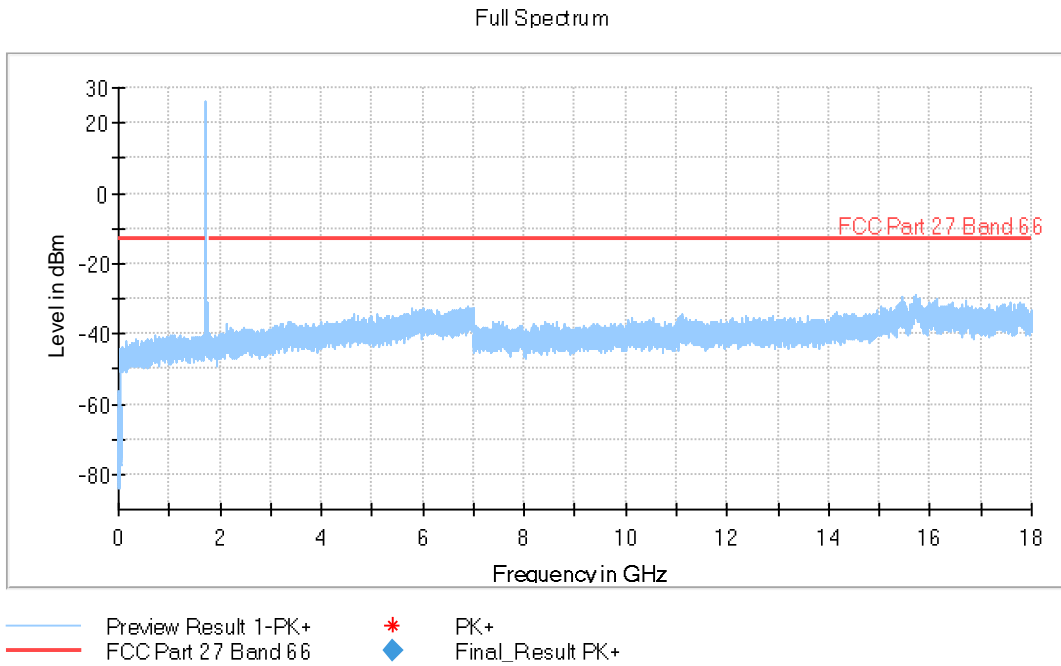

The peak above the limit is the carrier frequency.
 The highest peak next to the carrier is the Downlink frequency.

Middle Channel:

Full Spectrum

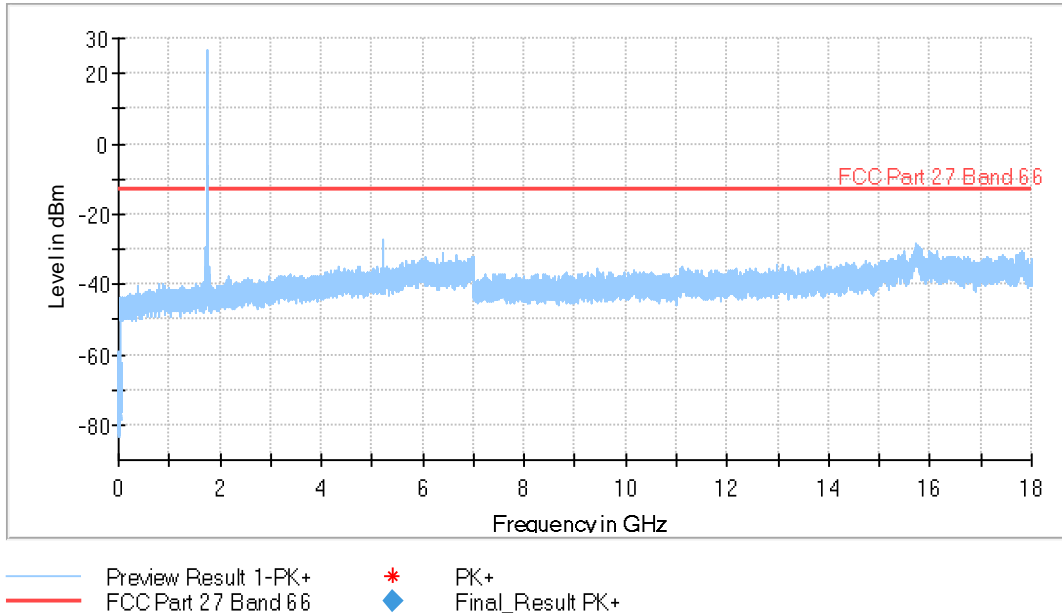

The peak above the limit is the carrier frequency.
The highest peak next to the carrier is the Downlink frequency.

High Channel:

Full Spectrum

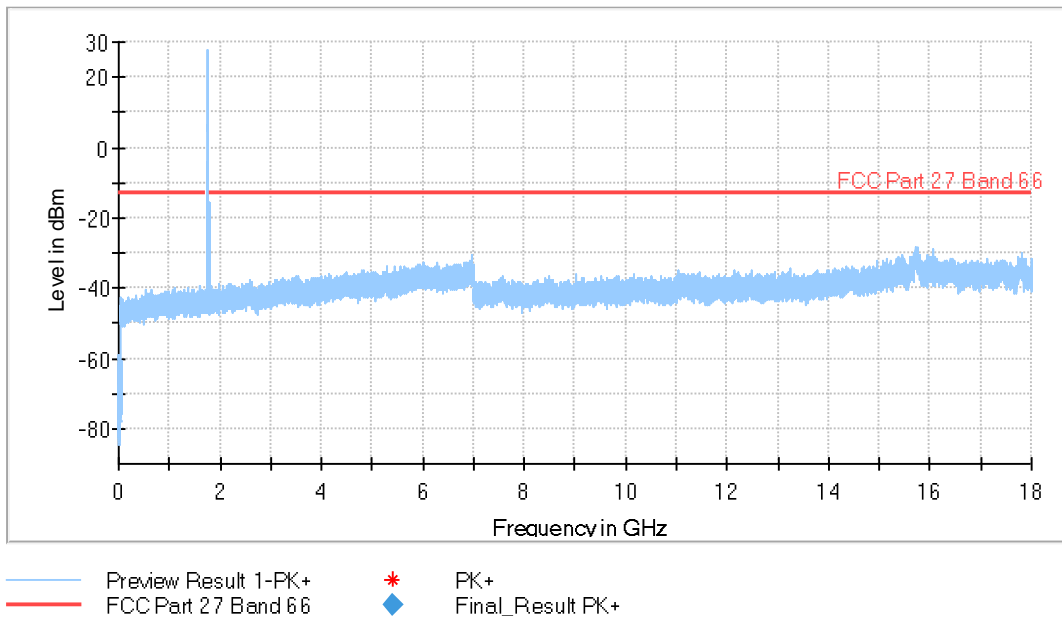

The peak above the limit is the carrier frequency.
The highest peak next to the carrier is the Downlink frequency.

LTE Cat 1bis Band 71. BW=15 MHz. QPSK. RB Size 1. RB Offset 0.

Subrange	Step Size	Detectors	Bandwidth	Sweep Time	Preamp
Receiver: [FSV 40]					
9 kHz - 150 kHz	14,1 Hz	PK+	300 Hz	Coupled	0 dB
150 kHz - 30 MHz	932,812 Hz	PK+	10 kHz	Coupled	0 dB
30 MHz - 1 GHz	30,312 kHz	PK+	100 kHz	Coupled	0 dB
1 GHz - 2 GHz	31,25 kHz	PK+	100 kHz	Coupled	0 dB
2 GHz - 3 GHz	31,25 kHz	PK+	100 kHz	Coupled	0 dB
3 GHz - 4 GHz	31,25 kHz	PK+	100 kHz	Coupled	0 dB
4 GHz - 5 GHz	31,25 kHz	PK+	100 kHz	Coupled	0 dB
5 GHz - 6 GHz	31,25 kHz	PK+	100 kHz	Coupled	0 dB
6 GHz - 7 GHz	31,25 kHz	PK+	100 kHz	Coupled	0 dB
7 GHz - 8 GHz	31,25 kHz	PK+	100 kHz	Coupled	0 dB

Low Channel:

Full Spectrum

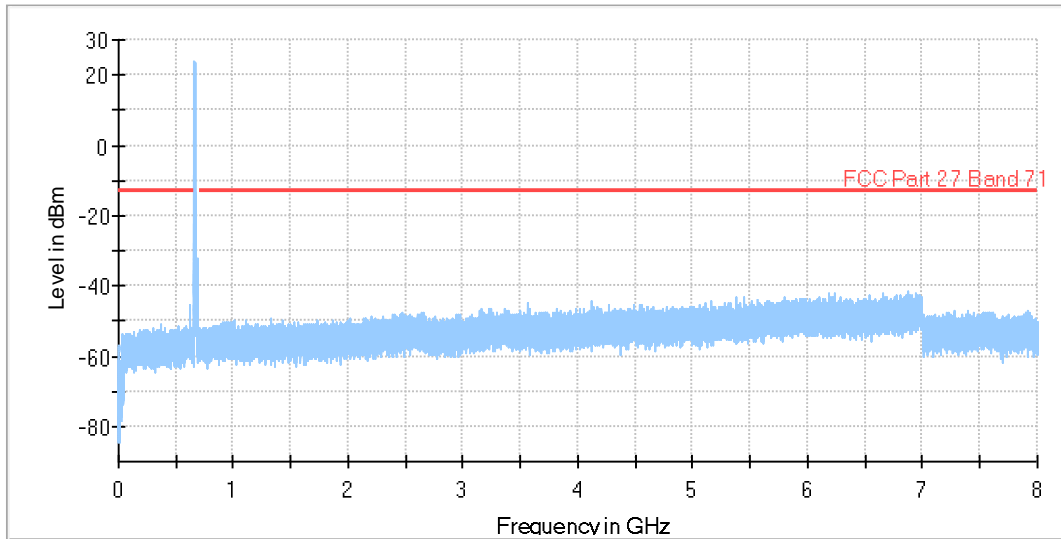

— Preview Result 1-PK+ * PK+
— FCC Part 27 Band 71 ◆ Final_Result PK+

The peak above the limit is the carrier frequency.
 The highest peak next to the carrier is the Downlink frequency.

Middle Channel:

Full Spectrum

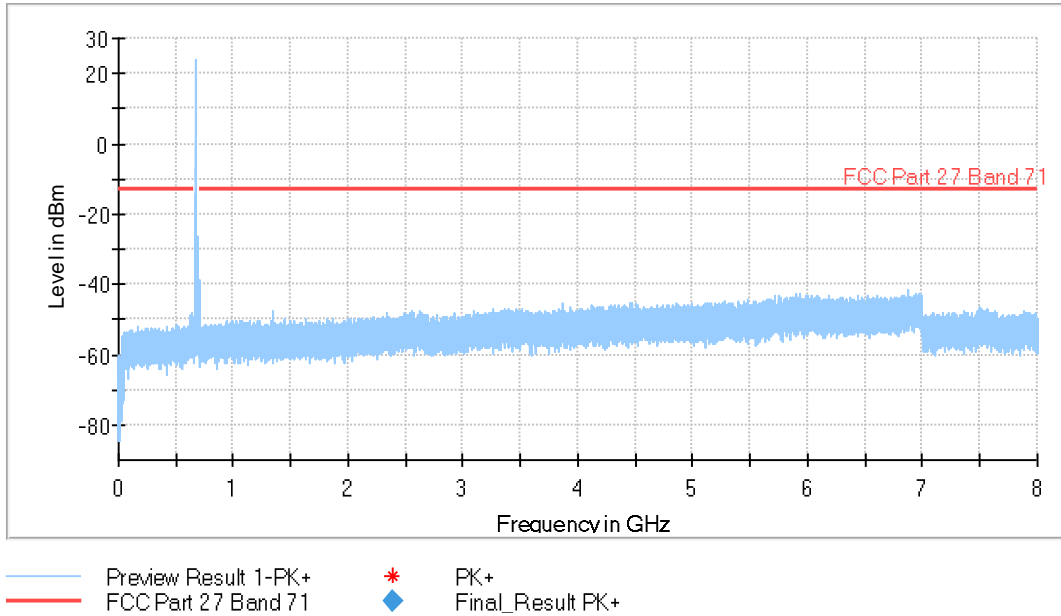

The peak above the limit is the carrier frequency.
 The highest peak next to the carrier is the Downlink frequency.

High Channel:

Full Spectrum

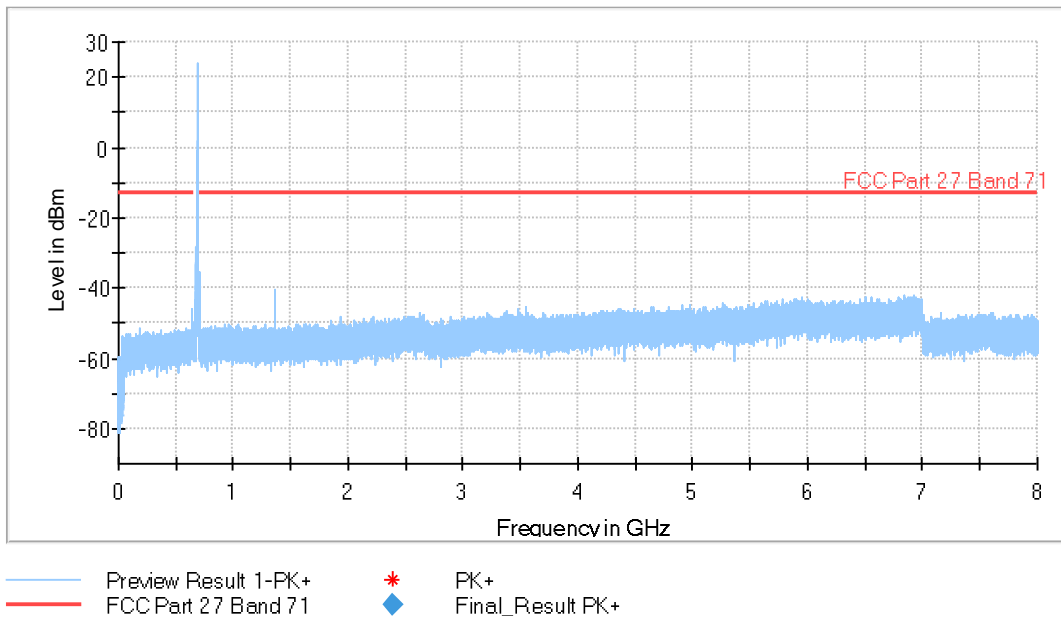

The peak above the limit is the carrier frequency.
 The highest peak next to the carrier is the Downlink frequency.

Spurious Emissions at Antenna Terminals at Block Edges

Limits

1. LTE Cat 1bis Bands 12.

* FCC §27.53 (g):

(g) For operations in the 600 MHz band and the 698–746 MHz band, the power of any emission outside a licensee's frequency band(s) of operation shall be attenuated below the transmitter power (P) within the licensed band(s) of operation, measured in watts, by at least $43 + 10 \log (P)$ dB. Compliance with this provision is based on the use of measurement instrumentation employing a resolution bandwidth of 100 kilohertz or greater. However, in the 100 kilohertz bands immediately outside and adjacent to a licensee's frequency block, a resolution bandwidth of at least 30 kHz may be employed.

* RSS-130, 4.7:

4.7.1 General unwanted emissions limits:

The unwanted emissions in any 100 kHz bandwidth on any frequency outside the low frequency edge and the high frequency edge of each frequency block range(s), shall be attenuated below the transmitter power, P (dBW), by at least $43 + 10 \log_{10} p$ (watts), dB. However, in the 100 kHz band immediately outside of the equipment's frequency block range, a resolution bandwidth of 30 kHz may be employed.

2. LTE Cat 1bis Band 13.

* FCC §27.53 (c):

(c) For operations in the 746-758 MHz band and the 776-788 MHz band, the power of any emission outside the licensee's frequency band(s) of operation shall be attenuated below the transmitter power (P) within the licensed band(s) of operation, measured in watts, in accordance with the following:

(1) On any frequency outside the 746–758 MHz band, the power of any emission shall be attenuated outside the band below the transmitter power (P) by at least $43 + 10 \log (P)$ dB;

(2) On any frequency outside the 776-788 MHz band, the power of any emission shall be attenuated outside the band below the transmitter power (P) by at least $43 + 10 \log (P)$ dB;

(3) On all frequencies between 763–775 MHz and 793–805 MHz, by a factor not less than $76 + 10 \log (P)$ dB in a 6.25 kHz band segment, for base and fixed stations;

(4) On all frequencies between 763–775 MHz and 793–805 MHz, by a factor not less than $65 + 10 \log (P)$ dB in a 6.25 kHz band segment, for mobile and portable stations;

(5) Compliance with the provisions of paragraphs (c)(1) and (c)(2) of this section is based on the use of measurement instrumentation employing a resolution bandwidth of 100 kHz or greater. However, in the 100 kHz bands immediately outside and adjacent to the frequency block, a resolution bandwidth of at least 30 kHz may be employed;

(6) Compliance with the provisions of paragraphs (c)(3) and (c)(4) of this section is based on the use of measurement instrumentation such that the reading taken with any resolution bandwidth setting should be adjusted to indicate spectral energy in a 6.25 kHz segment.

* RSS-130, 4.7:

4.7.1 General unwanted emissions limits:

The unwanted emissions in any 100 kHz bandwidth on any frequency outside the low frequency edge and the high frequency edge of each frequency block range(s), shall be attenuated below the transmitter power, P (dBW), by at least $43 + 10 \log_{10} p$ (watts), dB. However, in the 100 kHz band immediately outside of the equipment's frequency block range, a resolution bandwidth of 30 kHz may be employed.

4.7.2 Additional unwanted emissions limits:

In addition to the limit outlined in section 4.7.1 above, equipment operating in the frequency bands 746-756 MHz and 777-787 MHz shall also comply with the following restrictions:

- a. the power of any unwanted emissions in any 6.25 kHz bandwidth for all frequencies between 763-775 MHz and 793-806 MHz shall be attenuated below the transmitter power, P (dBW), by at least:
 - i. $76 + 10 \log_{10} p$ (watts), dB, for base and fixed equipment and
 - ii. $65 + 10 \log_{10} p$ (watts), dB, for mobile and portable equipment
- b. the e.i.r.p. in the band 1559-1610 MHz shall not exceed -70 dBW/MHz for wideband signal and -80 dBW for discrete emission with bandwidth less than 700 Hz.

3. LTE Cat 1bis Bands 4, 66.

* FCC §27.53 (h):

AWS emission limits:

(1) General protection levels. Except as otherwise specified below, for operations in the 1695–1710 MHz, 1710–1755 MHz, 1755–1780 MHz, 1915–1920 MHz, 1995–2000 MHz, 2000–2020 MHz, 2110–2155 MHz, 2155–2180 MHz, and 2180–2200 MHz bands, the power of any emission outside a licensee's frequency block shall be attenuated below the transmitter power (P) in watts by at least $43 + 10 \log_{10} (P)$ dB.

(3) Measurement procedure.

(i) Compliance with this provision is based on the use of measurement instrumentation employing a resolution bandwidth of 1 megahertz or greater. However, in the 1 megahertz bands immediately outside and adjacent to the licensee's frequency block, a resolution bandwidth of at least one percent of the emission bandwidth of the fundamental emission of the transmitter may be employed. The emission bandwidth is defined as the width of the signal between two points, one below the carrier center frequency and one above the carrier center frequency, outside of which all emissions are attenuated at least 26 dB below the transmitter power.

(ii) When measuring the emission limits, the nominal carrier frequency shall be adjusted as close to the licensee's frequency block edges, both upper and lower, as the design permits.

(iii) The measurements of emission power can be expressed in peak or average values, provided they are expressed in the same parameters as the transmitter power.

* RSS-139, 5.6:

Unwanted emissions shall be measured in terms of average value.

Equipment shall have the TRP or conducted power (all antenna connectors), of unwanted emissions outside the frequency block or frequency block group not exceeding the limits shown in the next table:

Offset from the edge of the frequency block or frequency block group	Unwanted emission limits
≤1 MHz	-13 dBm/(1% of OB)
>1 MHz	-13 dBm/MHz

Where OB is the occupied bandwidth.

At P_o transmitting power, the specified minimum attenuation becomes $43+10 \log (P_o)$, and the level in dBm relative to P_o becomes:

$$P_o \text{ (dBm)} - [43 + 10 \log (P_o \text{ in mW}) - 30] = -13 \text{ dBm}$$

4. LTE Cat 1bis Band 71.

* FCC §27.53 (g):

(g) For operations in the 600 MHz band and the 698–746 MHz band, the power of any emission outside a licensee's frequency band(s) of operation shall be attenuated below the transmitter power (P) within the licensed band(s) of operation, measured in watts, by at least $43 + 10 \log (P)$ dB. Compliance with this provision is based on the use of measurement instrumentation employing a resolution bandwidth of 100 kilohertz or greater. However, in the 100 kilohertz bands immediately outside and adjacent to a licensee's frequency block, a resolution bandwidth of at least 30 kHz may be employed.

* RSS-130, 4.7:

4.7.1 General unwanted emissions limits:

The unwanted emissions in any 100 kHz bandwidth on any frequency outside the low frequency edge and the high frequency edge of each frequency block range(s), shall be attenuated below the transmitter power, P (dBW), by at least $43 + 10 \log_{10} p$ (watts), dB. However, in the 100 kHz band immediately outside of the equipment's frequency block range, a resolution bandwidth of 30 kHz may be employed.

Method

The EUT RF output connector was connected to a spectrum analyser and to the Universal Radio Communication tester R&S CMW500 (selecting maximum transmission power of the EUT and different modes of modulation) using a 50-Ohm attenuator and a power splitter.

The reading of the spectrum analyser is corrected with the attenuation loss of connection between output terminal of EUT and input of the spectrum analyser.

Test Setup

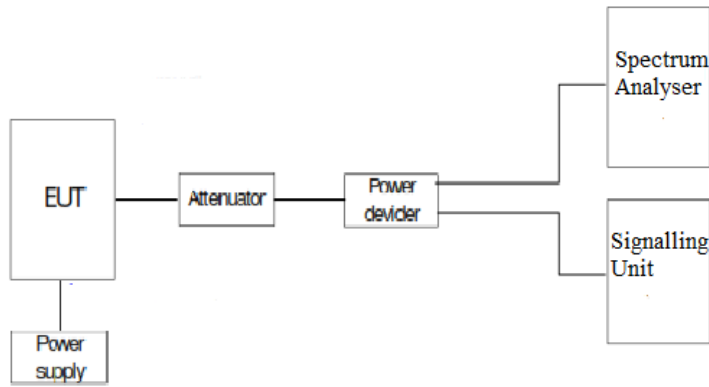

Results

LTE Cat 1bis Band 4:

Note: Low Block Edge for LTE Cat 1bis Band 4 is the same as for the LTE Cat 1bis Band 66.

Preliminary measurements determined QPSK, BW=3 MHz as the worst-case.

LTE QPSK MODULATION:	RB=1. Offset=Max. BW = 1.4 MHz	RB=1. Offset=Max. BW = 3 MHz	RB=1. Offset=Max. BW = 5 MHz	RB=1. Offset=Max. BW = 10 MHz	RB=1. Offset=Max. BW = 15 MHz	RB=1. Offset=Max. BW = 20 MHz
Maximum measured level at <u>High Block Edge</u> at antenna port (dBm)	-25.07	-20.88	-22.48	-25.68	-28.65	-31.8

LTE QPSK MODULATION:	RB = All. Offset = 0. BW = 1.4 MHz	RB = All. Offset = 0. BW = 3 MHz	RB = All. Offset = 0. BW = 5 MHz	RB = All. Offset = 0. BW = 10 MHz	RB = All. Offset = 0. BW = 15 MHz	RB = All. Offset = 0. BW = 20 MHz
Maximum measured level at <u>High Block Edge</u> at antenna port (dBm)	-30.82	-27.29	-27.32	-28.32	-32.05	-33.14

Measurement uncertainty: $\pm 2.76\text{ dB}$

Verdict

PASS

The plots below are for the worst case configuration specified before.

LTE Cat 1bis Band 4:

LTE Cat 1bis Band 4. BW=3 MHz. QPSK. RB=1. Offset=Max. High Block Edge:

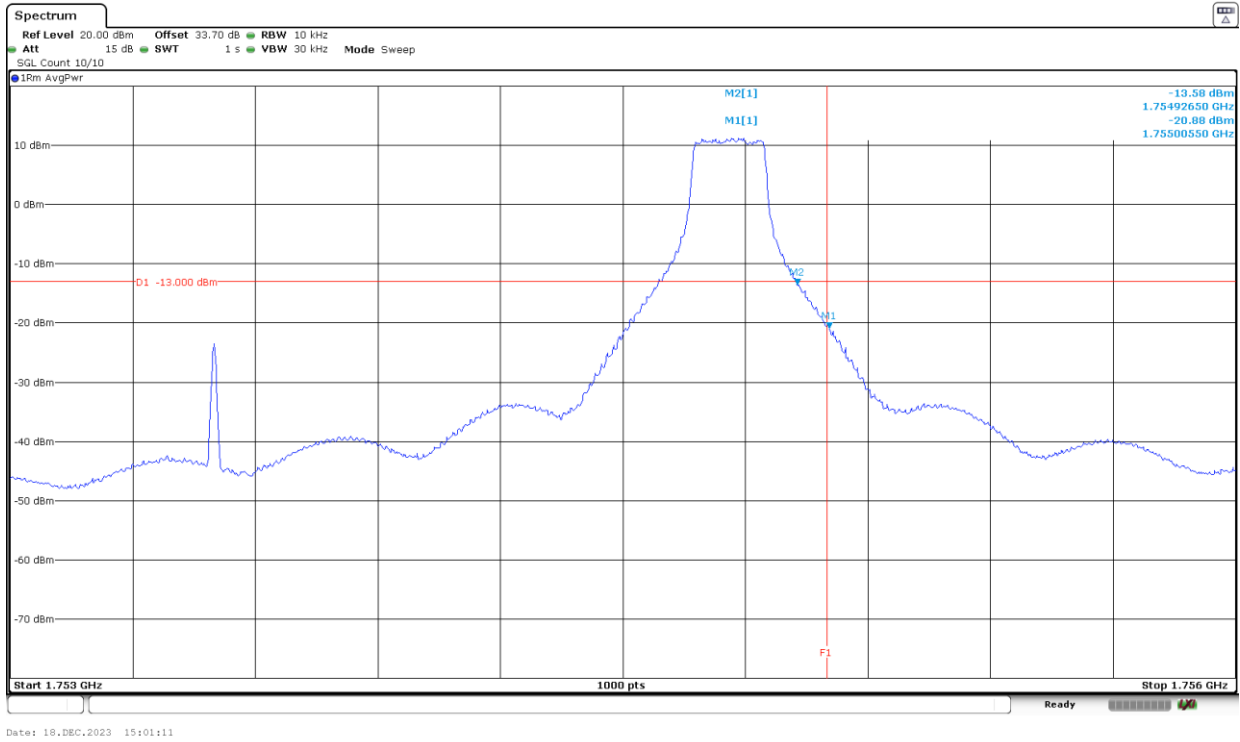

The equipment transmits at the maximum output power

LTE Cat 1bis Band 4. BW=3 MHz. QPSK. RB=All. Offset=0. High Block Edge:

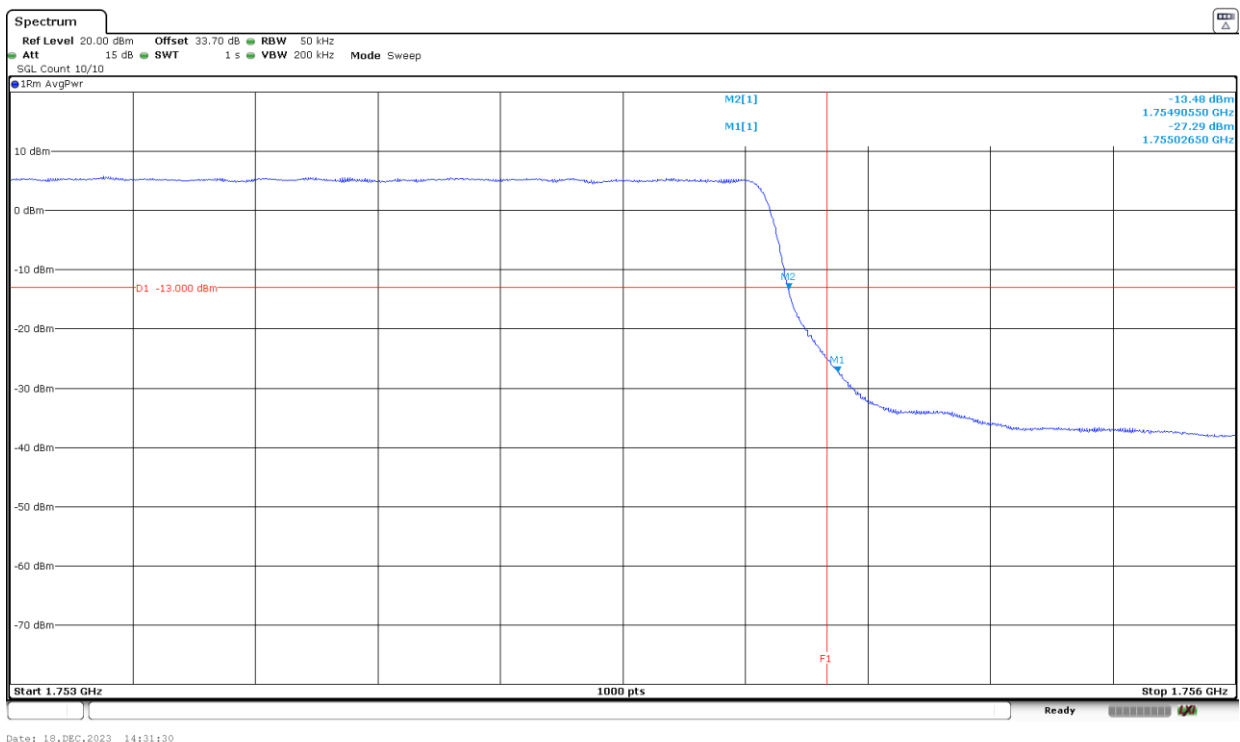

The equipment transmits at the maximum output power

LTE Cat 1bis Band 12:

Preliminary measurements determined QPSK, BW=5 MHz as the worst-case.

LTE QPSK MODULATION:	RB=1. Offset = 0. BW = 1.4 MHz	RB=1. Offset = 0. BW = 3 MHz	RB=1. Offset = 0. BW = 5 MHz	RB=1. Offset = 0. BW = 10 MHz
Maximum measured level at <u>Low Block Edge</u> at antenna port (dBm)	-48,01	-34,2	-40,9	-37,6

LTE QPSK MODULATION:	RB = All. Offset = 0. BW = 1.4 MHz	RB = All. Offset = 0. BW = 3 MHz	RB = All. Offset = 0. BW = 5 MHz	RB = All. Offset = 0. BW = 10 MHz
Maximum measured level at <u>Low Block Edge</u> at antenna port (dBm)	-44,67	-32,93	-35	-37,08

LTE QPSK MODULATION:	RB=1. Offset=Max. BW = 1.4 MHz	RB=1. Offset=Max. BW = 3 MHz	RB=1. Offset=Max. BW = 5 MHz	RB=1. Offset=Max. BW = 10 MHz
Maximum measured level at <u>High Block Edge</u> at antenna port (dBm)	-25.2	-18.81	-17.56	-19.66

LTE QPSK MODULATION:	RB = All. Offset = 0. BW = 1.4 MHz	RB = All. Offset = 0. BW = 3 MHz	RB = All. Offset = 0. BW = 5 MHz	RB = All. Offset = 0. BW = 10 MHz
Maximum measured level at <u>High Block Edge</u> at antenna port (dBm)	-28.69	-28.95	-29.77	-31.51

Measurement uncertainty: $\pm 2.76\text{ dB}$

Verdict

PASS

The plots below are for the worst case configuration specified before.

LTE Cat 1bis Band 12:

LTE Cat 1bis Band 12. BW=5 MHz. QPSK. RB=1. Offset=0. Low Block Edge:

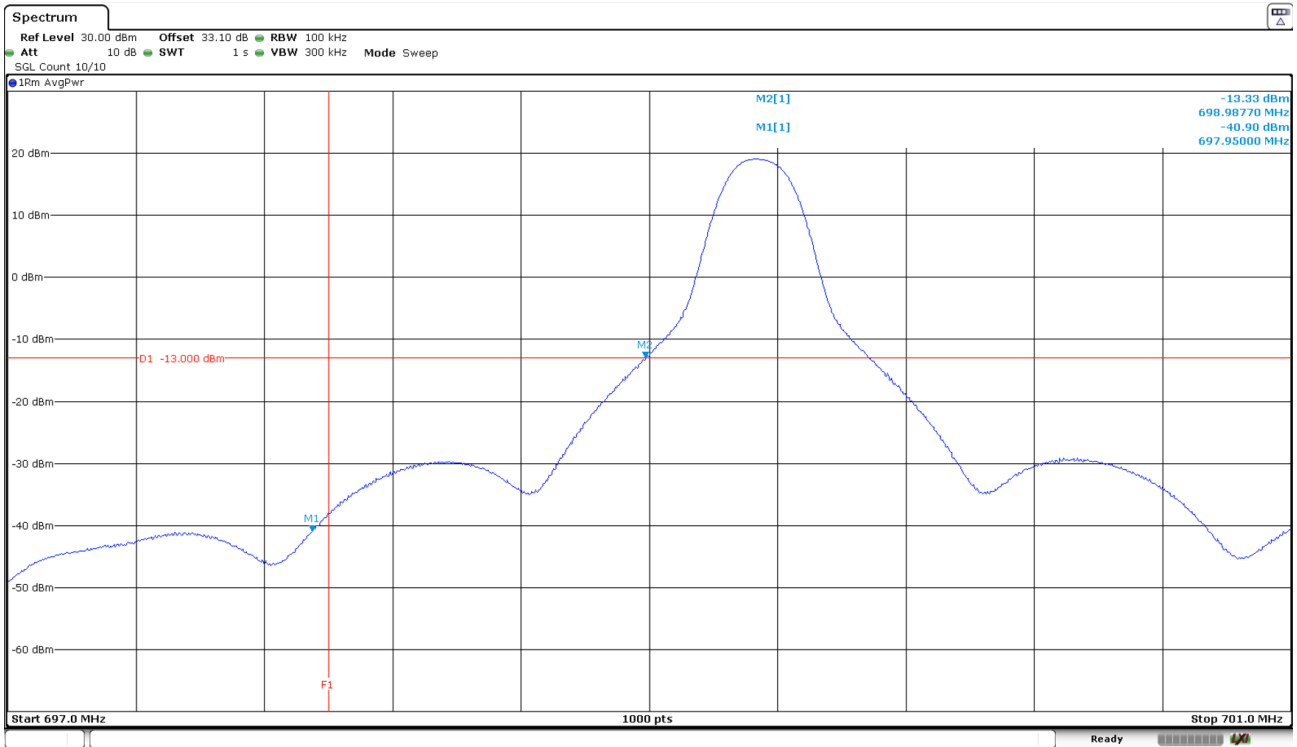

LTE Cat 1bis Band 12. BW=5 MHz. QPSK. RB=All. Offset=0. Low Block Edge:

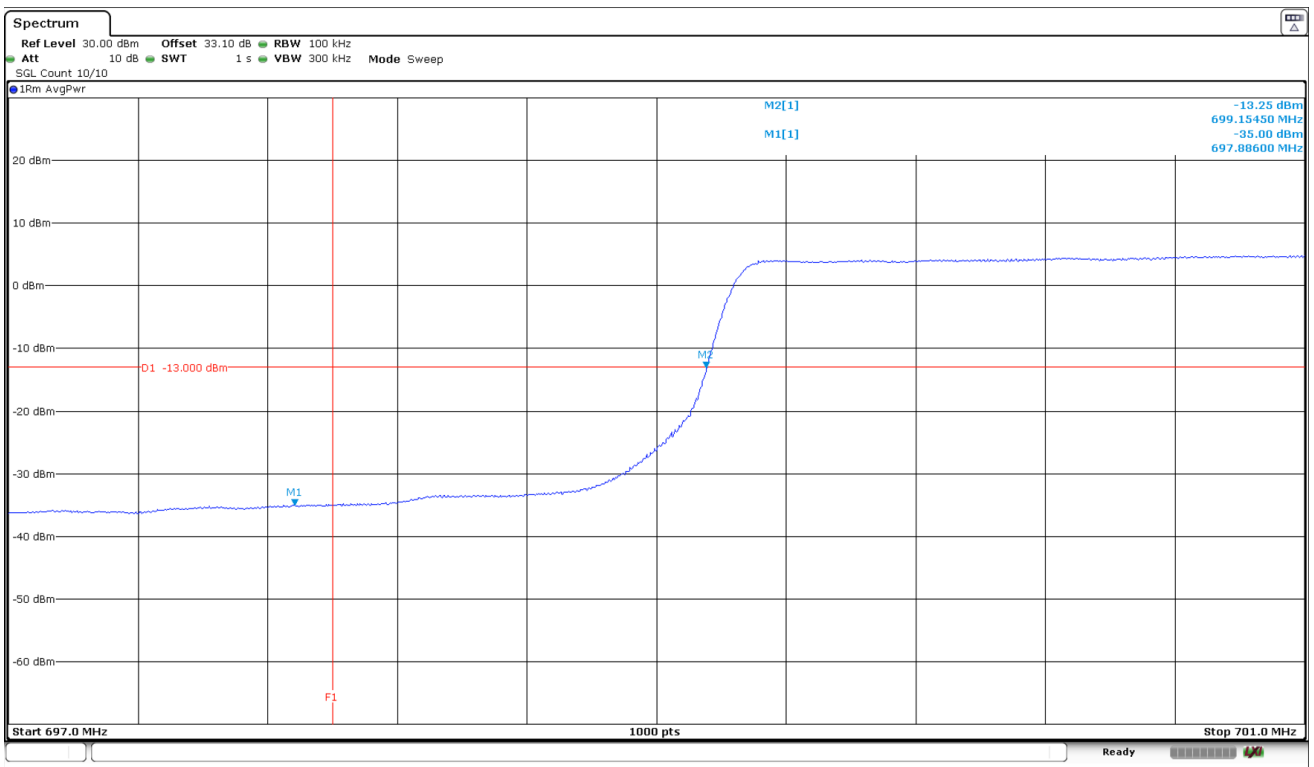

LTE Cat 1bis Band 12. BW=5 MHz. QPSK. RB=1. Offset=Max. High Block Edge:

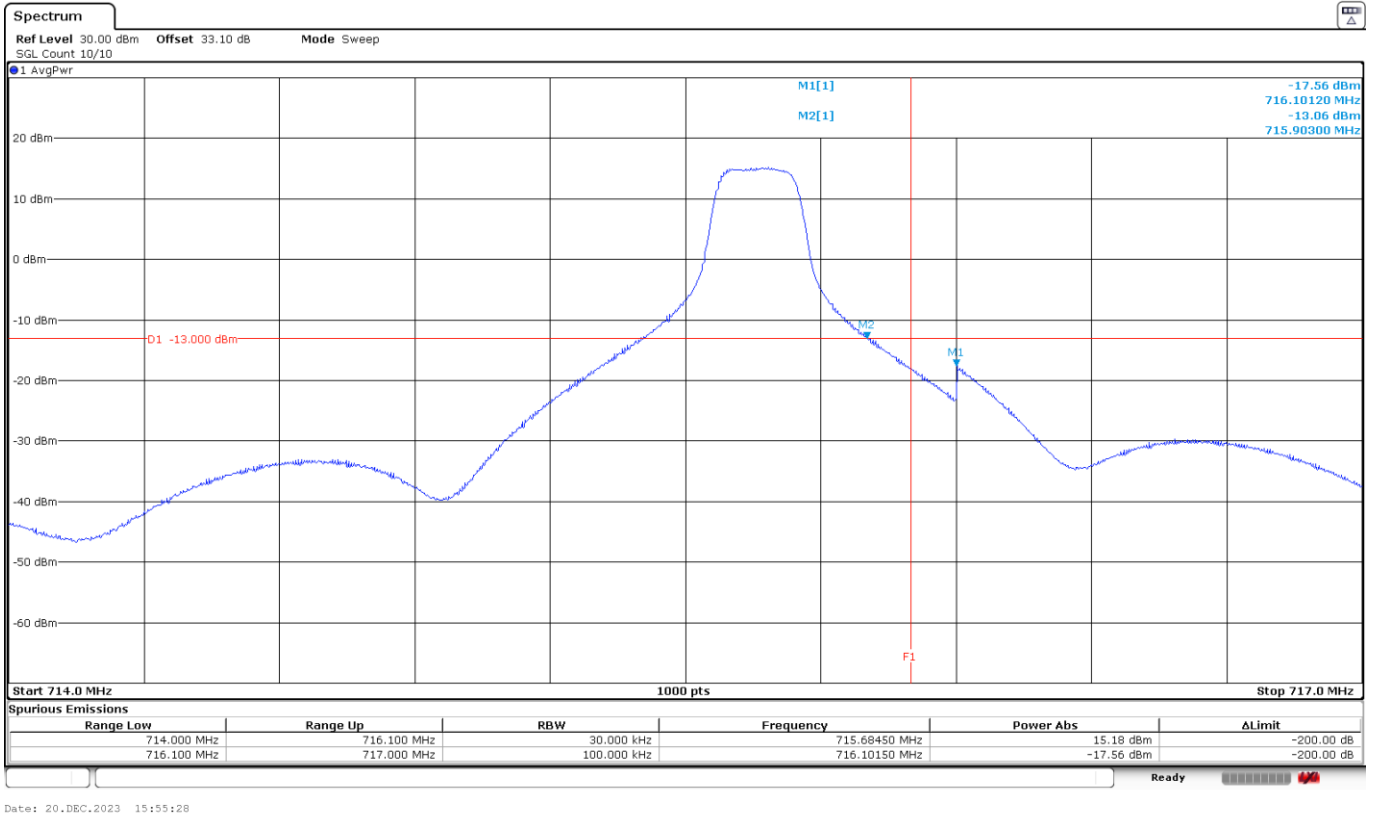

Date: 20.DEC.2023 15:55:28

LTE Cat 1bis Band 12. BW=5 MHz. QPSK. RB=All. Offset=0. High Block Edge:

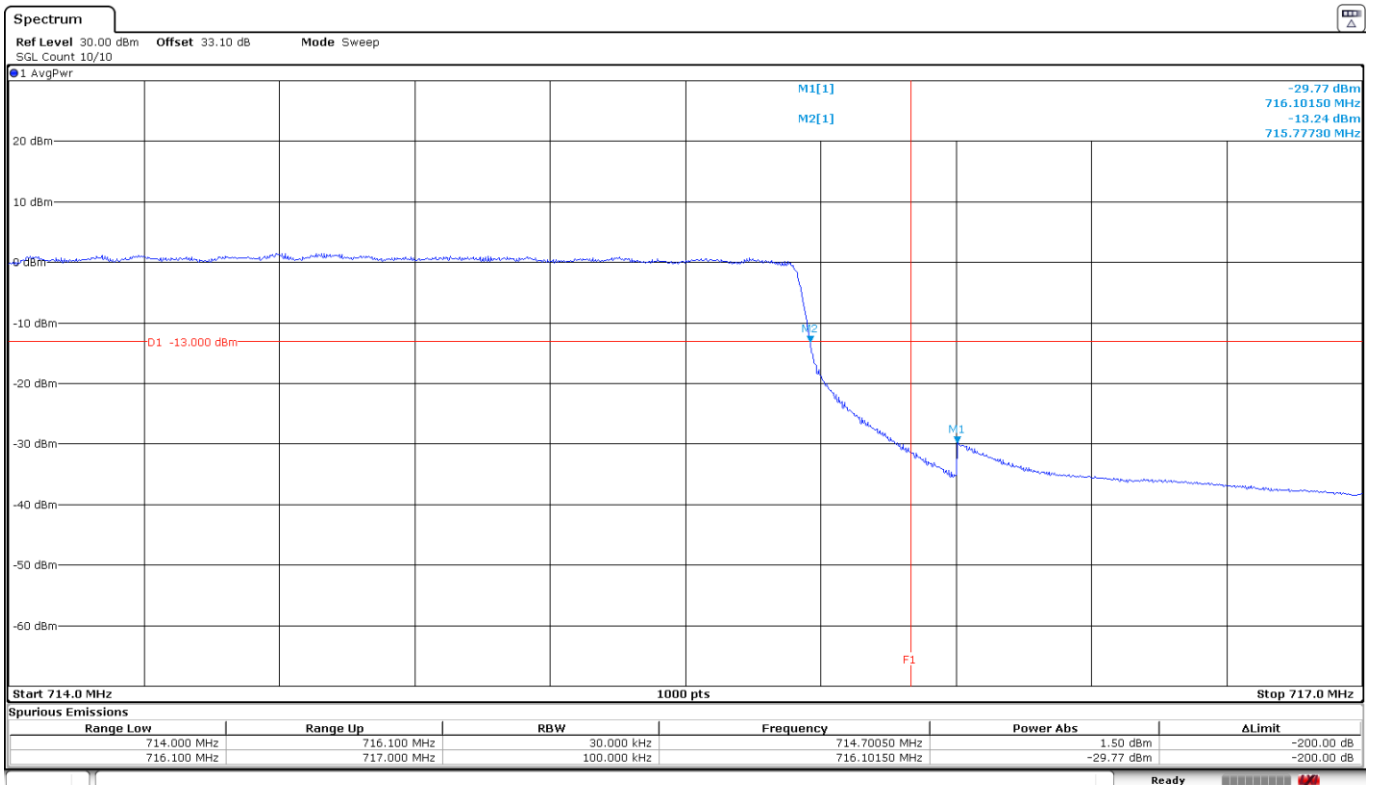

Date: 20.DEC.2023 15:06:19

LTE Cat 1bis Band 13:

Preliminary measurements determined QPSK, BW=5 MHz as the worst-case.

LTE QPSK:	RB=1. Offset = 0. BW = 5 MHz	RB=1. Offset = 0. BW = 10 MHz
Maximum measured level at <u>Low Block Edge</u> at antenna port (dBm)	-17.3	-19.16

LTE QPSK:	RB = All. Offset = 0. BW = 5 MHz	RB = All. Offset = 0. BW = 10 MHz
Maximum measured level at <u>Low Block Edge</u> at antenna port (dBm)	-29.34	-32.41

LTE QPSK:	RB=1. Offset=Max. BW = 5 MHz	RB=1. Offset=Max. BW = 10 MHz
Maximum measured level at <u>High Block Edge</u> at antenna port (dBm)	-16.84	-19.00

LTE QPSK:	RB = All. Offset = 0. BW = 5 MHz	RB = All. Offset = 0. BW = 10 MHz
Maximum measured level at <u>High Block Edge</u> at antenna port (dBm)	-29.14	-31.96

Measurement uncertainty: <±2.76 dB

Verdict

PASS

The plots below are for the worst case configuration specified before.

LTE Cat 1bis Band 13:

LTE Cat 1bis Band 13. BW=5 MHz. QPSK. RB=1. Offset=0. Low Block Edge:

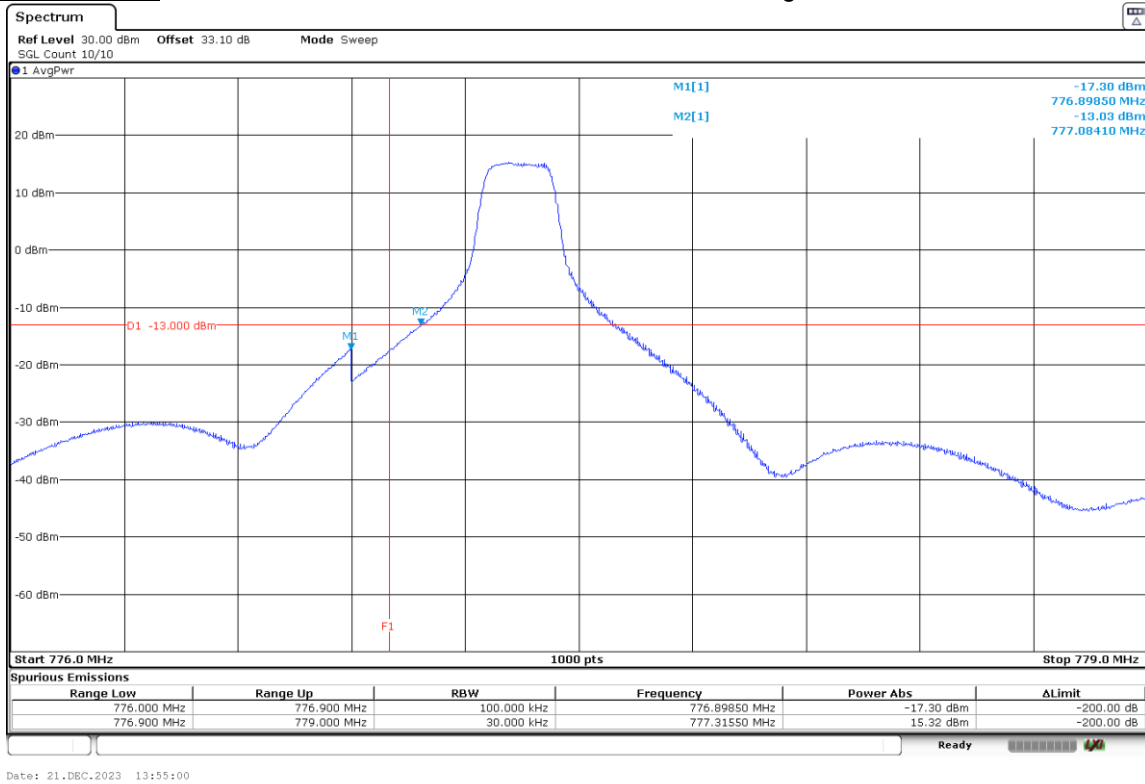

The equipment transmits at the maximum output power

LTE Cat 1bis Band 13. BW=5 MHz. QPSK. RB=All. Offset=0. Low Block Edge:

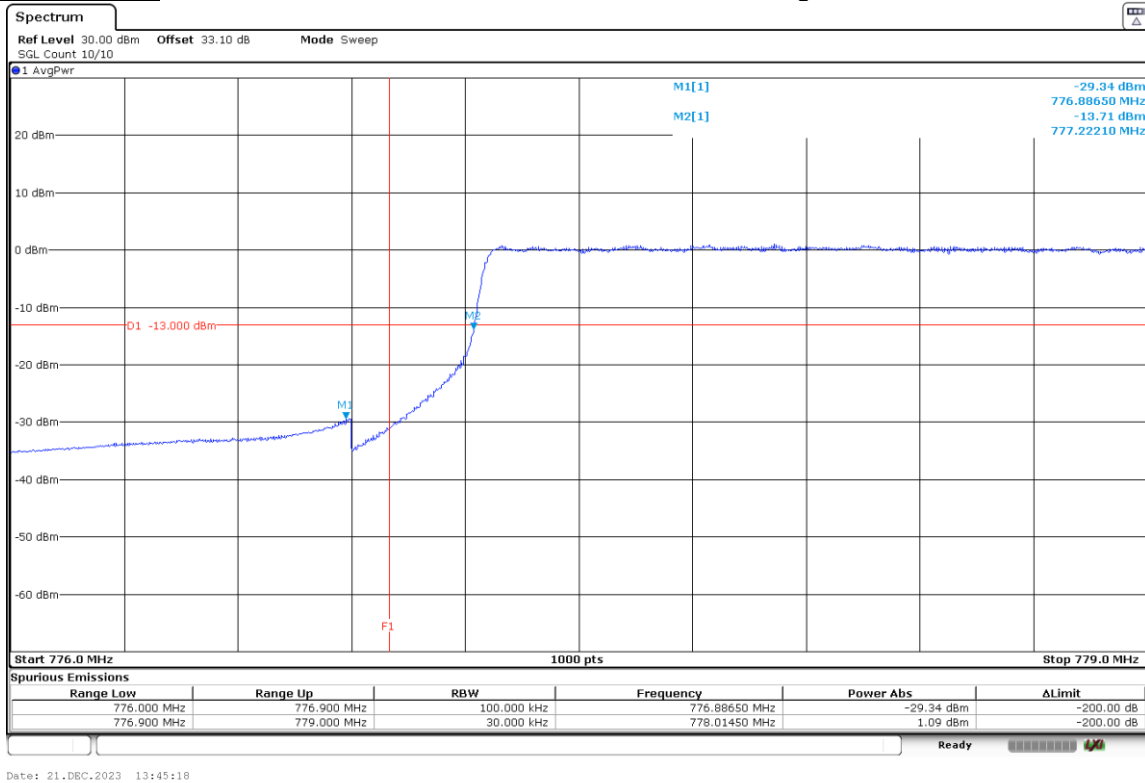

The equipment transmits at the maximum output power

LTE Cat 1bis Band 13. BW=5 MHz. QPSK. RB=1. Offset=Max. High Block Edge:

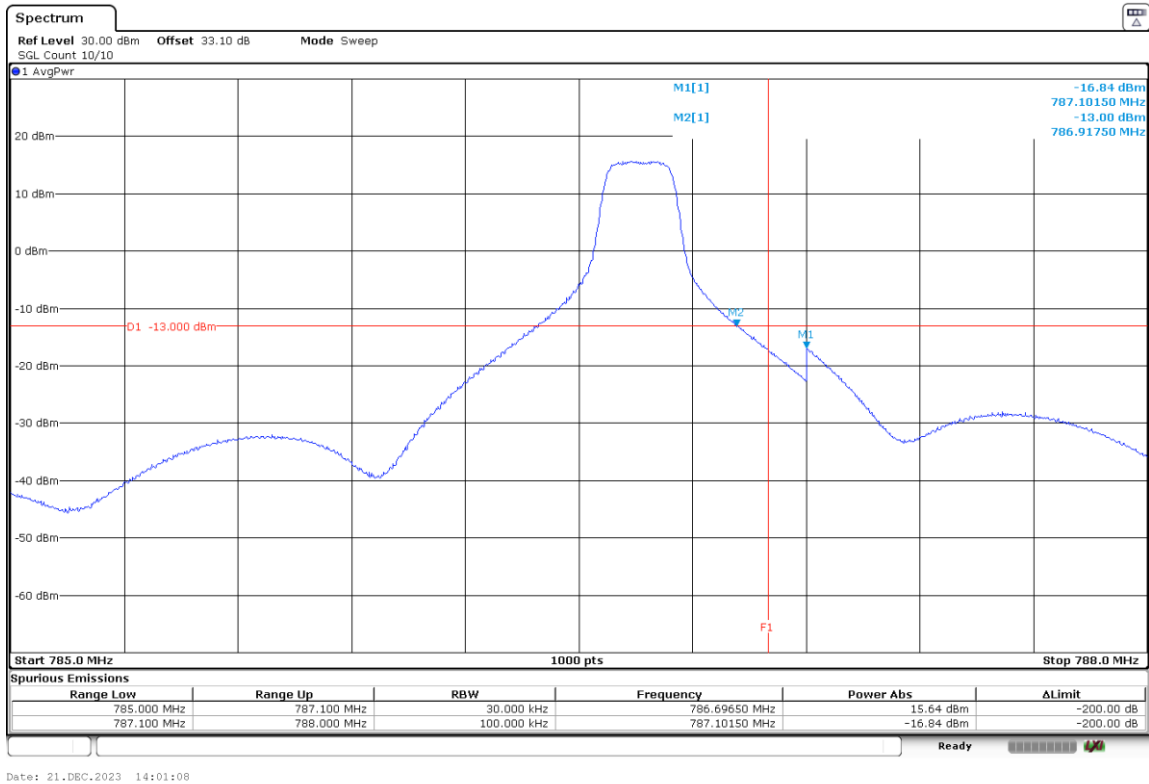

The equipment transmits at the maximum output power

LTE Cat 1bis Band 13. BW=5 MHz. QPSK. RB=All. Offset=0. High Block Edge:

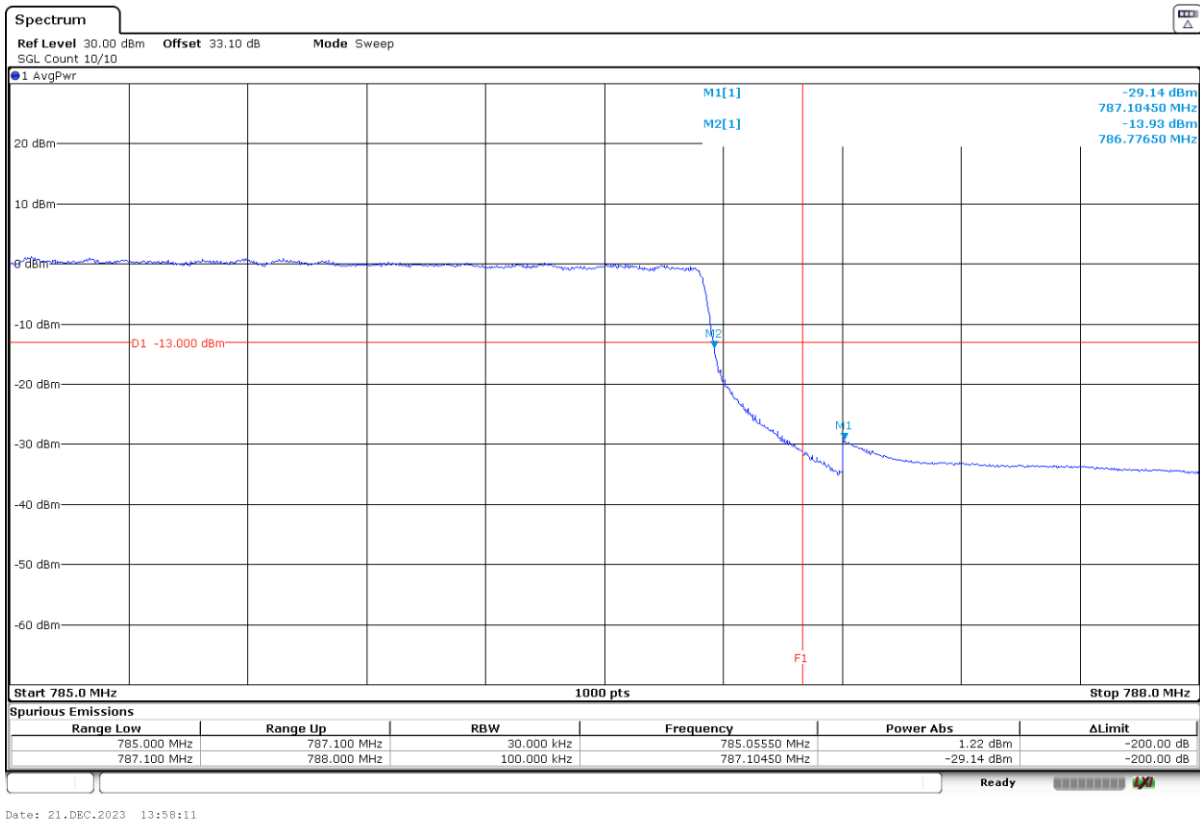

The equipment transmits at the maximum output power

LTE Cat 1bis Band 66:

Preliminary measurements determined QPSK, BW=3 MHz.

LTE QPSK MODULATION:	RB=1. Offset = 0. BW = 1.4 MHz	RB=1. Offset = 0. BW = 3 MHz	RB=1. Offset = 0. BW = 5 MHz	RB=1. Offset = 0. BW = 10 MHz	RB=1. Offset = 0. BW = 15 MHz	RB=1. Offset = 0. BW = 20 MHz
Maximum measured level at <u>Low Block Edge</u> at antenna port (dBm)	-27.13	-20.78	-22.45	-26.97	-29.3	-32.43

LTE QPSK MODULATION:	RB = All. Offset = 0. BW = 1.4 MHz	RB = All. Offset = 0. BW = 3 MHz	RB = All. Offset = 0. BW = 5 MHz	RB = All. Offset = 0. BW = 10 MHz	RB = All. Offset = 0. BW = 15 MHz	RB = All. Offset = 0. BW = 20 MHz
Maximum measured level at <u>Low Block Edge</u> at antenna port (dBm)	-31.46	-27.13	-27.85	-29.89	-31.86	-33.33

LTE QPSK MODULATION:	RB=1. Offset=Max. BW = 1.4 MHz	RB=1. Offset=Max. BW = 3 MHz	RB=1. Offset=Max. BW = 5 MHz	RB=1. Offset=Max. BW = 10 MHz	RB=1. Offset=Max. BW = 15 MHz	RB=1. Offset=Max. BW = 20 MHz
Maximum measured level at <u>High Block Edge</u> at antenna port (dBm)	-32	-21.23	-22.53	-26.73	-28.9	-32.04

LTE QPSK MODULATION:	RB = All. Offset = 0. BW = 1.4 MHz	RB = All. Offset = 0. BW = 3 MHz	RB = All. Offset = 0. BW = 5 MHz	RB = All. Offset = 0. BW = 10 MHz	RB = All. Offset = 0. BW = 15 MHz	RB = All. Offset = 0. BW = 20 MHz
Maximum measured level at <u>High Block Edge</u> at antenna port (dBm)	-30.15	-27.37	-27.61	-29.48	-32.3	-34.42

Measurement uncertainty: $\pm 2.76\text{ dB}$

Verdict

PASS