



Test report No:

NIE: 45639RRF.006A1

Test report (Modification 1)
REFERENCE STANDARDS:

FCC 47CFR Part 2.1093, Published RF Exposure KDB Procedures

Identification of item tested.....:	Internet of Things developer device						
Trade	Thingsee						
Model and /or type reference	TSONE						
Other identification of the product	FCC ID: 2AEU3TSONE IC: 20236-TSONE Contains pre-certified modules:						
	<table border="1"> <tr> <td>Model: SARA-G350</td> <td>Model: CC3000EM</td> </tr> <tr> <td>FCC ID: XPYSARAG350</td> <td>FCC ID: Z64-CC3000EM</td> </tr> <tr> <td>IC: 8595A-SARAG350</td> <td>IC: 4511-CC3000EM</td> </tr> </table>	Model: SARA-G350	Model: CC3000EM	FCC ID: XPYSARAG350	FCC ID: Z64-CC3000EM	IC: 8595A-SARAG350	IC: 4511-CC3000EM
Model: SARA-G350	Model: CC3000EM						
FCC ID: XPYSARAG350	FCC ID: Z64-CC3000EM						
IC: 8595A-SARAG350	IC: 4511-CC3000EM						
Final HW version	0404						
Final SW version	2015.06.01.1						
IMEI TAC	35381605 (SARA 2G modem IMEI TAC)						
Features	2G/GPRS, WLAN, Bluetooth, Set of sensors						
Manufacturer.....:	Company name: THINGSEE OY Postal Address: Yrttipellontie 1 D, 90230 Oulu, Finland Contact Person: Anu Lapola Telephone: +358504877365 e-mail:anu.lapolathingsee.com						
Test method requested, standard.....:	<ol style="list-style-type: none"> 1. FCC 47 CFR Part 2.1093. (10-1-14 Edition) Radiofrequency radiation exposure evaluation: portable devices. 2. FCC OET KDB 447498 D01 General RF Exposure Guidance v05r02 (February 2014) 3. FCC OET KDB 865664 D01 v01r03 – SAR Measurement Requirements for 100 MHz to 6 GHz (February 2014). 4. FCC OET KDB 248227 D01 802.11 Wi-Fi SAR v02 (March 2015). 5. IC RSS-102 Issue 5 (2015-03) – Radio Frequency Exposure Compliance of Radiocommunication Apparatus (All Frequency Bands) 						

	<p>6. Canada`s Safety Code No.6 – Limits of Human Exposure to Radiofrequency Electromag-netic Fields in the Frequency Range from 3 kHz to 300 GHz</p>
<p>Summary</p>	<p>Considering the results of the performed test according to FCC 47CFR Part 2.1093, the item under test is IN COMPLIANCE with the requested specifications specified in the standards.</p> <p>The maximum 1g volume reported SAR found during this test has been 1.397 W/kg, for the 850 MHz Band and GPRS 2 slots mode.</p> <p>The maximum 1g volume reported SAR for simultaneous multi-band transmission found during this test has been 1.548 W/kg.</p> <p>NOTE: The results presented in this Test Report apply only to the particular item under test established in page 1 of this document, as presented for test on the date(s) shown in section, “USAGE OF SAMPLES, TESTING PERIOD AND ENVIRONMENTAL CONDITIONS”.</p>
<p>Approved by (name / position & signature)</p>	<p>Miguel Lacave p.p. Antenna Lab Manager</p>
<p>Date of issue</p>	<p>2015-08-13</p>
<p>Report template No.....</p>	<p>FDT11_17</p>

Index

Competences and guarantees	4
General conditions	4
Uncertainty	4
Usage of samples	5
Test sample description	5
Identification of the client	5
Testing period	5
Environmental conditions	5
Modifications to the reference test report	6
Remarks and comments	6
Testing verdicts	8
Appendix A – Test configuration	9
Appendix B – Test results	19
Appendix C – Measurement report	31
Appendix D – System Validation Reports	36
Appendix E – Calibration data	40
Appendix E – Photographs	90

Competences and guarantees

AT4 wireless is a testing laboratory accredited by the National Accreditation Body (ENAC-Entidad Nacional de Acreditación), to perform the tests according to FCC 47CFR Part 2.1093 as indicated in the Certificate No. 51/LE 147.

In order to assure the traceability to other national and international laboratories, AT4 wireless has a calibration and maintenance program for its measurement equipment.

AT4 wireless guarantees the reliability of the data presented in this report, which is the result of the measurements and the tests performed to the item under test on the date and under the conditions stated on the report and, it is based on the knowledge and technical facilities available at AT4 wireless at the time of performance of the test.

AT4 wireless is liable to the client for the maintenance of the confidentiality of all information related to the item under test and the results of the test.

The results presented in this Test Report apply only to the particular item under test established in this document.

IMPORTANT: No parts of this report may be reproduced or quoted out of context, in any form or by any means, except in full, without the previous written permission of AT4 wireless.

General conditions

1. This report is only referred to the item that has undergone the test.
2. This report does not constitute or imply on its own an approval of the product by the Certification Bodies or competent Authorities.
3. This document is only valid if complete; no partial reproduction can be made without previous written permission of AT4 wireless.
4. This test report cannot be used partially or in full for publicity and/or promotional purposes without previous written permission of AT4 wireless and the Accreditation Bodies.

Uncertainty

Uncertainty (factor $k=2$) was calculated according to the following documents:

1. FCC OET KDB 865664 D01 - SAR Measurement 100 MHz to 6 GHz (February 2014).

Usage of samples

Samples undergoing test have been selected by: the client

Sample M/01 is composed of the following elements:

Control N°	Description	Model	Serial N°	Date of reception
45639C/003	AC/DC Adapter	AC-60E	-	2015-06-02
45639C/004	USB Cable	CA-101	-	2015-06-02
45639C/005	USB Cable	-	-	2015-06-02
45639C/006	Thingseeone Conducted Sample	TSO001	XNG51760113	2015-06-02

Sample M/02 is composed of the following elements:

Control N°	Description	Model	Serial N°	Date of reception
45639C/003	AC/DC Adapter	AC-60E	-	2015-06-02
45639C/004	USB Cable	CA-101	-	2015-06-02
45639C/005	USB Cable	-	-	2015-06-02
45639C/002	Thingseeone Cellular Radiated Sample	TSO001	XNG51760176	2015-06-02
45639C/009	Thingseeone WiFi Radiated Sample	TSO001	XNG51760171	2015-06-02

Sample M/01 has undergone the test(s) specified in subclause “Test method requested”: Conducted average output power.

Sample M/02 has undergone the test(s) specified in subclause “Test method requested”: SAR evaluation for 2G and 802.11 b/g modes.

Test sample description

The test sample consists of a portable device.

Identification of the client

Company name: THINGSEE OY

Postal Address: Yrttipellontie 1 D, 90230 Oulu, Finland

Contact Person: Anu Lapola

Telephone: +358504877365

e-mail: anu.lapolathingsee.com

Testing period

The performed test started on 2015-06-04 and finished on 2015-06-11.

The tests have been performed at AT4 wireless.

Environmental conditions

In the laboratory for measurements, the following limits were not exceeded during the test:

Temperature	Min. = 21.20 °C Max. = 24.78 °C
Relative humidity	Min. = 43.02 % Max. = 62.49 %

Modifications to the reference test report

It was introduced the following modifications in respect to the test report number 45639RRF.006 related with the same samples, in the next clauses and sub-clauses:

Clauses / Sub-clauses	Modification	Justification
Title Page - Summary	The maximum 1g volume reported SAR for simultaneous multiband transmission has been added.	Updated needed due to modifications to the reference test report.
Appendix B. 1.3. Test signal, Output Power and Frequencies.	Target power alignments for RF components have been included.	More detailed information requested.
Appendix B.2.2.2. Wi-Fi & Bluetooth.	Detailed conducted peak & average power table for Bluetooth has been included.	More detailed information requested.
Appendix B.2.2.2. Wi-Fi & Bluetooth.	Additional Bluetooth SAR test exclusion threshold for the theoretical maximum output power per tune-up procedure value has been included.	More detailed information requested.
Appendix 5.5.2. Result for 1g body simultaneous multi-band transmission	Table values have been updated.	Updated needed.

This modification test report cancels and replaces the test report 45639RRF.006.

Remarks and comments

- 1: Testing of other required channels is not required according to FCC OET KDB 447498 D01 General RF Exposure Guidance v05r02, paragraph “4.3.3. SAR test reduction considerations”.
- 2: Testing of Bluetooth mode is not required according to FCC OET KDB 447498 D01 General RF Exposure Guidance v05r02 (February 2014), paragraph “4.3.1. Standalone SAR test exclusion considerations Individual Transmitters” and IC RSS-102 Issue 5 (2015-03) – Radio Frequency Exposure Compliance of Radiocommunication Apparatus (All Frequency Bands).
- 3: Only the plots of the highest reported SAR for each test position and mode/band are included in appendix C.

Used instrumentation

1. Dosimetric E-field probes SPEAG ES3DV3
2. Data acquisition device SPEAG DAE4
3. Electro-optical converter SPEAG EOC3
4. 900 MHz dipole validation kit SPEAG D900V2
5. 1800 MHz dipole validation kit SPEAG D1800V2
6. 2450 MHz dipole validation kit SPEAG D2450V2
7. Robot STÄUBLI RX60BL, Robot controller STÄUBLI CS7MB
8. Measurement server SPEAG DASY5 SE UMS 011 BS
9. Oval flat phantom SPEAG ELI 4
10. Device positioner SD000 HD1 HA
11. SAR measurement software SPEAG DASY52 V52.8.8.1222
12. SAR postprocessing software SPEAG SEMCAD X
13. Body Tissue Equivalent Liquid for 900, 1800 and 2450 MHz bands
14. Universal Radio Communication Tester R&S CMU 200
15. Vector network analyzer Agilent FieldFox N9923A
16. Dielectric probe kit SPEAG DAK-3.5
17. Power meter Agilent E4419B
18. Power meter R&S NRVD and power sensor R&S NRV-Z51
19. RF Generator R&S SMU200
20. DC Power supply Agilent U8002A
21. Dual directional couplers HP 778D and NARDA 4227-16
22. Power amplifier MITEQ AMF-4D-00400600-50-30P

Testing verdicts

Not applicable	:	N/A
Pass	:	P
Fail	:	F
Not measured	:	N/M

850 MHz band

FCC 47CFR Part 2.1093 Paragraph	VERDICT			
	NA	P	F	NM
(d)(2) GPRS	P			

1900 MHz band

FCC 47CFR Part 2.1093 Paragraph	VERDICT			
	NA	P	F	NM
(d)(2) GPRS	P			

2450 MHz band

FCC 47CFR Part 2.1093 Paragraph	VERDICT			
	NA	P	F	NM
(d)(2) 802.11b	P			
(d)(2) 802.11g	P			
(d)(2) Bluetooth LE	P ²			

2: See remarks and comments.

Appendix A – Test configuration

INDEX

1.	GENERAL INTRODUCTION	11
1.1.	Application Standard.....	11
1.2.	General requirements	11
1.3.	Measurement system requirements	11
1.4.	Phantom requirements.....	11
1.5.	Measurement Liquids requirements.	11
2.	MEASUREMENT SYSTEM.....	12
2.1.	Measurement System	12
2.2.	Test Positions of device relative to body	16
2.3.	Test to be performed	16
2.4.	Description of interpolation/extrapolation scheme	16
2.5.	Determination of the largest peak spatial-average SAR	16
2.6.	System Validation	16
3.	UNCERTAINTY.....	17
4.	SAR LIMIT	18
5.	DEVICE UNDER TEST	18
5.1.	Dimensions.....	18
5.2.	Wireless Technology.....	18
5.3.	Simultaneous Transmission.....	18
5.4.	DUT Antenna Location.....	18

1. GENERAL INTRODUCTION

1.1. Application Standard

The Federal Communications Commission (FCC) sets the limits for General Population / Uncontrolled exposure to radio frequency electromagnetic fields for transmitting devices designed to be used within 20 centimetres of the body of the user under FCC 47 CFR Part 2.1093 - “Radiofrequency radiation exposure evaluation: portable devices”, paragraph (d)(2).

1.2. General requirements

The SAR measurement has been performed continuing the following considerations and environment conditions:

- The ambient temperature shall be in the range of 18°C to 25°C and the variation shall not exceed +/- 2°C during the test.
- The ambient humidity shall be in the range of and 30% - 70%.
- The device battery shall be fully charged before each measurement.

1.3. Measurement system requirements

The measurement system used for SAR tests fulfils the procedural and technical requirements described at the reference standards used.

1.4. Phantom requirements

The phantom model for body measurements is an elliptical open-top container with a flat bottom, with the following shape and dimension:

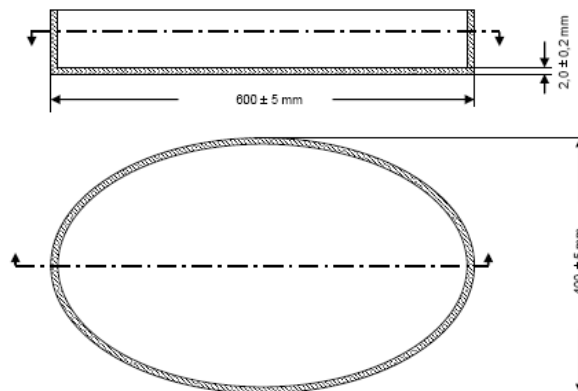

Figure 1: Proportions and shape of Phantom shell

1.5. Measurement Liquids requirements.

The liquids used to simulate the human tissues, must fulfil the requirements of the dielectric properties required. These target dielectric properties per FCC OET KDB 450824 instructions come from the dipole and probe calibration data which are included in Appendix B, Section 3, of this document.

To minimize the effect of reflections on peak spatial-average SAR values, from the upper surface of the tissue-equivalent liquid, the depth of the liquid should be at least 15 cm.

2. MEASUREMENT SYSTEM

2.1. Measurement System

The DASY5 system for performing compliance tests consists of the following items:

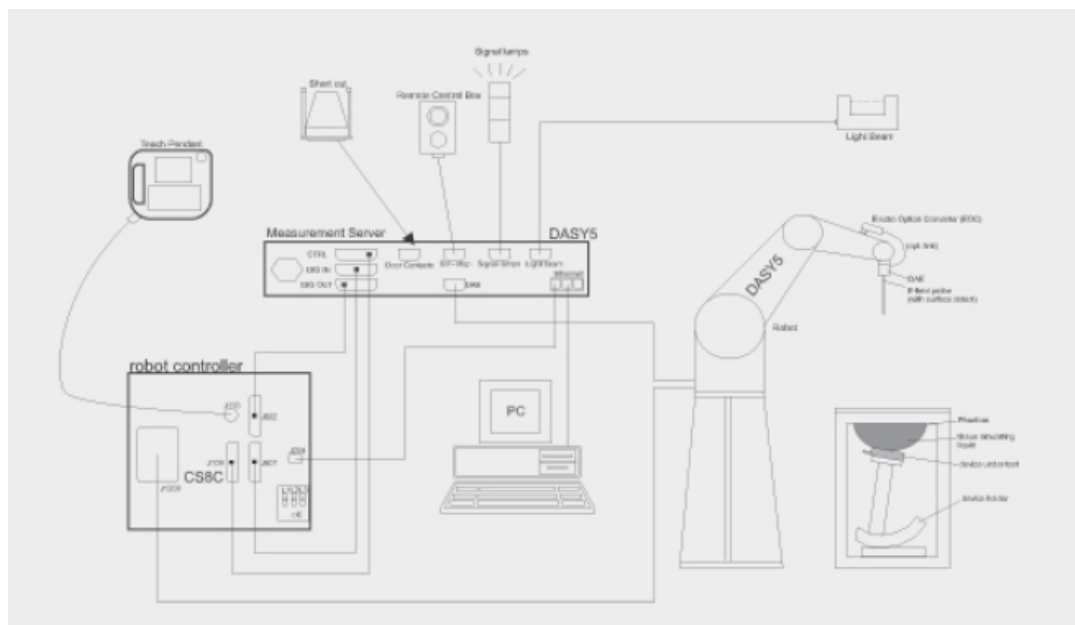

Figure 2: SAR Measurement system

- A standard high precision 6-axis robot (Stäubli TX=RX family) with controller, teach pendant and software. An arm extension for accommodating the data acquisition electronics (DAE).
- An isotropic field probe optimized and calibrated for the targeted measurement.
- A data acquisition electronics (DAE) which performs the signal amplification, signal multiplexing, AD-conversion, offset measurements, mechanical surface detection, collision detection, etc. The unit is battery powered with standard or rechargeable batteries. The signal is optically transmitted to the EOC.
- The Electro-optical converter (EOC) performs the conversion from optical to electrical signals for the digital communication to the DAE. To use optical surface detection, a special version of the EOC is required. The EOC signal is transmitted to the measurement server.
- The function of the measurement server is to perform the time critical tasks such as signal filtering, control of the robot operation and fast movement interrupts.
- The Light Beam used is for probe alignment. This improves the (absolute) accuracy of the probe positioning.
- A computer running Win7 professional operating system and the DASY5 software.
- Remote control and teach pendant as well as additional circuitry for robot safety such as warning lamps, etc.
- The phantom, the device holder and other accessories according to the targeted measurement.

Manufacturer	Device	Type
Schmid & Partner Engineering AG	Dosimetric E-Field Probe	ES3DV3
Schmid & Partner Engineering AG	Data Acquisition Electronics	DAE4
Schmid & Partner Engineering AG	Electro-Optical Converter	EOC3
Stäubli	Robot	RX60BL
Stäubli	Robot controller	CS7MB
Schmid & Partner Engineering AG	Measurement Server	DASY5 SE UMS 011 BS
Schmid & Partner Engineering AG	Oval flat phantom	SPEAG ELI 4
Schmid & Partner Engineering AG	Handset Positioner	SD000 HD1HA
Schmid & Partner Engineering AG	Measurement Software	DASY52 V52.8.8.1222
Schmid & Partner Engineering AG	Postprocessing Software	SEMCAD X
Rohde & Schwarz	RF Generator	SMU 200A
MITEQ	Power amplifier	AMF-4D-00400600-50-30P
Agilent	DC Power supply	U8002A
NARDA	Directional coupler	FSCM 99899
HP	Dual directional coupler	778D
Weinschel	6dB attenuator	75A-6-11
Weinschel	20dB attenuator	75A-20-11
Rohde & Schwarz	Power Meter & Power Sensor	NRVD & NRV-Z51
Agilent	Power Meter	E4419B
Schmid & Partner Engineering AG	900 MHz System Validation Dipole	D900V2
Schmid & Partner Engineering AG	1800 MHz System Validation Dipole	D1800V2
Schmid & Partner Engineering AG	2450 MHz System Validation Dipole	D2450V2
Agilent	Vector Network Analyser	FieldFox N9923A
Schmid & Partner Engineering AG	Dielectric Probe Kit	DAK-3.5
Rohde & Schwarz	Radio Communication Tester	CMU 200

Table 1: Measurement Equipment

DOSIMETRIC E-FIELD PROBE

ES3DV3

Isotropic E-Field Probe for Dosimetric Measurements



Symmetrical design with triangular core
 Interleaved sensors
 Built-in shielding against static charges
 PEEK enclosure material (resistant to organic solvents, e.g., DGBE)

Calibration	ISO/IEC 17025
Frequency	10 MHz to 4 GHz; Linearity: ± 0.2 dB (30 MHz to 4 GHz)
Directivity	± 0.2 dB in TSL (rotation around probe axis) ± 0.3 dB in TSL (rotation normal to probe axis)
Dynamic Range	5 μ W/g to > 100 mW/g; Linearity: ± 0.2 dB
Dimensions	Overall length: 337 mm (Tip: 20 mm) Tip diameter: 3.9 mm (Body: 12 mm) Distance from probe tip to dipole centers: 2.0 mm

DATA ACQUISITION ELECTRONICS

DAE4 - Data Acquisition Electronics



Signal amplifier, multiplexer, A/D converter, and control logic
 Serial optical link for communication with DASY4/5 embedded system (fully remote controlled)
 Two-step probe touch detector for mechanical surface detection and emergency robot stop

Measurement Range	-100 to +300 mV (16 bit resolution and two range settings: 4mV, 400mV)
Input Offset Voltage	< 5 μ V (with auto zero)
Input Resistance	200 M Ω m
Input Bias Current	< 50 fA

OVAL FLAT PHANTOM

ELI



Phantom for compliance testing of handheld and body-mounted wireless devices in the frequency range of 30 MHz to 6 GHz. ELI is fully compatible with the IEC 62209-2 standard and all known tissue simulating liquids. ELI has been optimized regarding its performance and can be integrated into our standard phantom tables. A cover prevents evaporation of the liquid. Reference markings on the phantom allow installation of the complete setup, including all predefined phantom positions and measurement grids, by teaching three points. The phantom is compatible with all SPEAG dosimetric probes and dipoles.

ELI V5.0 has the same shell geometry and is manufactured from the same material as ELI4, but has reinforced top structure.

Material	Vinylester, glass fiber reinforced (VE-GF)
Liquid Compatibility	Compatible with all SPEAG tissue simulating liquids (incl. DGBE type)
Shell Thickness	2.0 \pm 0.2 mm (bottom plate)
Dimensions	Major axis: 600 mm Minor axis: 400 mm
Filling Volume	approx. 30 liters
Wooden Support	SPEAG standard phantom table

HANDSET POSITIONER



Mounting Device for Hand-Held Transmitters

In combination with the Twin SAM V5.0/V5.0c or ELI Phantoms, the Mounting Device for Hand-Held Transmitters enables rotation of the mounted transmitter device to specified spherical coordinates. At the heads, the rotation axis is at the ear opening. Transmitter devices can be easily and accurately positioned according to IEC 62209-1, IEEE 1528, FCC, or other specifications. The device holder can be locked for positioning at different phantom sections (left head, right head, flat).

Material: Polyoxymethylene (POM)

DIPOLES

System Validation Kits 300 MHz – 6 GHz



Symmetrical dipole with I/4 balun
 Enables measurement of feedpoint impedance with NWA
 Matched for use near flat phantoms filled with tissue simulating solutions

Calibration	ISO/IEC 17025		
Frequency	300, 400, 450, 600, 733, 750, 835, 850, 900, 1300, 1450, 1500, 1640, 1750, 1800, 1900, 1950, 2000, 2100, 2300, 2450, 2550, 2600, 3000, 3300, 3500, 3700 MHz and D5GHz (5100-5800 MHz)		
Return Loss	> 20 dB at specified validation position		
Power Capability	> 100 W ($f < 1\text{GHz}$); > 40 W ($f > 1\text{GHz}$)		
Dimensions (length and overall height in mm)	Product	Dipole length	Overall height
	D750V3	179.0	330.0
	D900V2	148.5	340.0
	D1800V2	72.5	300.0
	D2000V2	65.0	300.0
	D2450V2	52.0	290.0
	D2600V2	49.2	290.0
D5GHzV2	20.6	300.0	

2.2. Test Positions of device relative to body

According to FCC OET KDB 447498 v05r02, devices that support transmission while used with body-worn accessories must be tested for body-worn accessory SAR compliance.

Body-worn accessory SAR compliance must be based on a single minimum test separation distance for all wireless and operating modes applicable to each body-worn accessory used by the host, according to the relevant voice and/or data mode transmissions and operations.

The device under test could be described as a body-worn device, which only supports data mode transmissions. 1-g SAR testing has been performed for each supported frequency band, positioning both faces at 15 mm distance testing from the flat phantom, as specified by the manufacturer.

2.3. Test to be performed

DUT will be placed at the center of flat phantom. The DUT position used during the body SAR tests will be the one where the maximum peak SAR was found. Each data mode, wireless technology and frequency band supported by the device must be tested. Low and high channels for each band should be tested at this position.

If the device is also designed to transmit with other configurations (antenna fully extended/retracted, keypad cover opened/closed...), all tests described above shall be performed for each configuration. When considering multi-mode and multi-band mobile phones, all of the tests shall be performed at each transmitting mode/band with the corresponding maximum peak power level.

2.4. Description of interpolation/extrapolation scheme

The local SAR inside the Phantom is measured using small dipole sensing elements inside a probe element. The probe tip must not be in contact with the Phantom's surface in order to minimize measurement errors, but the highest local SAR is obtained from measurements at a certain distance from the shell through extrapolation. The accurate assessment of the maximum SAR averaged over 1 gr and 10 gr. requires a very fine resolution in the three-dimensional scanned data array. Since the measurements have to be performed over a limited time, the measured data have to be interpolated to provide an array of sufficient resolution.

The interpolation of 2D area scan is used after the initial area scan, at a fixed distance from the Phantom shell wall. The initial scan data is collected with approx. 15 mm spatial resolution and this interpolation is used to find the location of the local maximum for positioning the subsequent 3D scanning within a 1 mm resolution.

For the 3D scan, data is collected on a spatially regular 3D grid having 5 mm steps in both directions. After the data collection by the SAR probe, the data are extrapolated in the depth direction to assign values to points in the 3D array closer to the shell wall. A notional extrapolation value is also assigned to the first point outside the shell wall so that subsequent interpolation schemes will be applicable right up to the shell wall boundary.

2.5. Determination of the largest peak spatial-average SAR

To determine the maximum value of the peak spatial-average SAR of a DUT, all device positions, configurations and operational modes should be tested for each frequency band.

The averaging volume shall be chosen as 1 gr. of contiguous tissue. The cubic volumes, over which the SAR measurements are averaged after extrapolation and interpolation, are chosen in order to include the highest values of local SAR.

The maximum SAR level for the DUT will be the maximum level obtained of the performed measurements, and indicated in the previous points.

2.6. System Validation

Prior to the SAR measurements, system verification is done to verify the system accuracy. A complete SAR evaluation is done using a half-wavelength dipole as source with the frequency of the mid-band channel of the operating band, or within 10% of this channel.

The measured 1 gr. and 10 gr. SAR should be within 10% of the expected target values specified in the calibration certificate of the dipole, for the specific tissue and frequency used.

3. UNCERTAINTY

Uncertainty for 300 MHz – 6 GHz

ERROR SOURCES	Uncertainty value (± %)	Probability distribution	Divisor	(c _i) 1g	(c _i) 10g	Standard uncertainty (1g) (± %)	Standard uncertainty (10g) (± %)
Measurement Equipment							
Probe Calibration	6.550	N	1	1	1	6.550	6.550
Isotropy	7.558	R	√3	1	1	4.364	4.364
Linearity	4.700	R	√3	1	1	2.714	2.714
Probe modulation response	2.300	R	√3	1	1	1.328	1.328
Detection limits	0.250	R	√3	1	1	0.144	0.144
Boundary effect	2.000	R	√3	1	1	1.155	1.155
Readout electronics	0.300	N	1	1	1	0.300	0.300
Response time	0.000	R	√3	1	1	0.000	0.000
Integration time	1.900	R	√3	1	1	1.097	1.097
RF Ambien conditions - noise	3.000	R	√3	1	1	1.732	1.732
RF Ambien conditions – reflections	3.000	R	√3	1	1	1.732	1.732
Probe positioner mech. restrictions	0.400	R	√3	1	1	0.231	0.231
Probe positioning with respect to phantom shell	6.700	R	√3	1	1	3.868	3.868
Post-processing	4.000	R	√3	1	1	2.309	2.309
Test Sample Related							
Device holder uncertainty	2.900	N	1	1	1	2.900	2.900
Test sample positioning	3.600	N	1	1	1	3.600	3.600
Drift of output power	5.000	R	√3	1	1	2.887	2.887
Phantom and Setup							
Phantom uncertainty (shape and thickness tolerances)	7.900	R	√3	1	1	4.561	4.561
Algorithm for correcting SAR for deviations in permittivity and conductivity	1.900	N	1	1	0.84	1.900	1.596
Liquid conductivity (meas.)	3.350	N	1	0.78	0.71	2.613	2.379
Liquid permittivity (meas.)	1.500	N	1	0.23	0.26	0.345	0.390
Liquid conductivity – temperature uncertainty	0.440	R	√3	0.78	0.71	0.198	0.180
Liquid permittivity – temperature uncertainty	3.120	R	√3	0.23	0.26	0.414	0.468
Combined standard uncertainty	$u_c = \sqrt{\sum_{i=1}^m c_i^2 \cdot u_i^2}$					12.70	12.62
Expanded uncertainty (confidence interval of 95%)	$u_e = 2.00 u_c$					25.40	25.23

Table 2: Uncertainty Assessment for 300 MHz - 6 GHz

4. SAR LIMIT

Having a worst case measurement, the SAR limit is valid for general population/uncontrolled exposure.

The SAR values have to be averaged over a mass of 1 gr. (SAR 1 gr.) with the shape of a cube and averaged over a mass of 10 gr (Extremity SAR 10 gr). These levels couldn't exceed the values indicated in the application Standard:

Standard	SAR	SAR Limit (W/Kg)
FCC 47 CFR Part 2.1093 Paragraph (d)(2)	SAR _{1 gr.}	1.6

Table 3: SAR limit

5. DEVICE UNDER TEST

5.1. Dimmensions

Dimmensions	Millimetres
Height x Width x Depth	110.0 x 66.0 x 18.0
Overall Diagonal:	112.0
Display Diagonal:	90.0

Table 4: DUT dimmensions

5.2. Wireless Technology

Wireless Technology	Frequency Bands	Modes
GSM	850 / 1900	- GPRS (GMSK, Multi-slot class 10)
Wi-Fi	2.4 GHz	- 802.11b/g
Bluetooth	2.4 GHz	- Bluetooth Low Energy

Table 5: DUT supported modes

5.3. Simultaneous Transmission

RF Exposure Condition	Capable Transmit Configurations*
Body-Worn	GPRS 850/1900 + WiFi 2.4GHz + BT
	* Available in future releases

Table 6: DUT simultaneous transmission

5.4. DUT Antenna Location

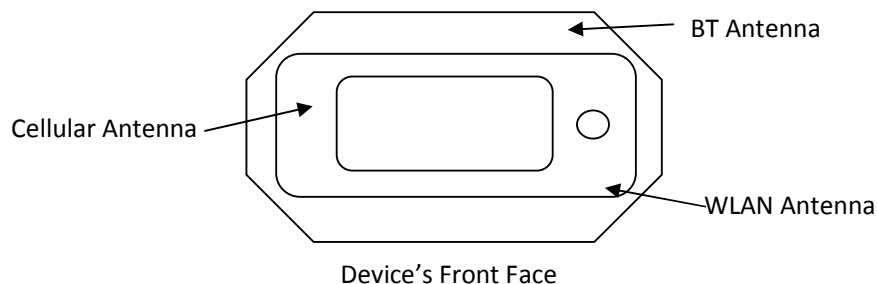

Figure 3: DUT Antenna location

Appendix B – Test results

INDEX

1.	TEST CONDITIONS.....	21
1.1.	Power supply (V):	21
1.2.	Temperature (°C):.....	21
1.3.	Test signal, Output Power and Frequencies	21
1.4.	DUT and test-site configurations	22
2.	CONDUCTED AVERAGE POWER MEASUREMENTS.....	23
2.1.	GPRS Bands.....	23
2.2.	Wi-Fi & Bluetooth	24
3.	TISSUE PARAMETERS MEASUREMENTS	27
4.	SYSTEM CHECK MEASUREMENTS	28
5.	MEASUREMENT RESULTS FOR SAR (SPECIFIC ABSORPTION RATE)	28
5.1.	Summary maximum results for 1-g body SAR measurements.	28
5.2.	Result for 1g body simultaneous multi-band transmission	28
5.3.	Results for GPRS 850 MHz band – 2 slots.	29
5.4.	Results for GPRS 1900 MHz Band – 2 slots.	29
5.5.	Results for Wi-Fi 2450 MHz Band.	30

1. TEST CONDITIONS

1.1. Power supply (V):

$V_n = 3.8$ Li-polymer rechargeable battery

Type of power supply = DC Voltage from rechargeable Li-Ion 3.8 V battery.

1.2. Temperature (°C):

$T_n = +21.00$ to $+25.00$

The subscript n indicates normal test conditions.

1.3. Test signal, Output Power and Frequencies

For the GPRS operational mode, the sample (S/N: XNG51760176) were put into operation by using a R&S CMU 200 as base station simulator. The output power of the device was set to Power Control Level (PCL) maximum for all tests.

For the 802.11 b/g, the sample (S/N: XNG51760171) were put into operation by using a test mode software, setting the maximum output power for each mode. The duty factor was set to maximum (aprox. 100%). A fully charged battery was used for every test sequence.

In all operating bands and test positions, output power of the device was set to transmit at maximum power for all tests. Measurements were performed on middle channels. In each band, for those positions where the maximum averaged SAR was found, measurements were performed on lowest and highest channels.

The maximum time-average conducted power of the device for each mode was measured with a Power meter R&S NRVD and a thermocoupled power sensor NRV-Z51.

The actual SAR sample does not have accessible antenna connectors for conducted measurements, so the conducted average output power was measured using another identical sample provided by the manufacturer with auxiliary external connectors that make measurements representative and applicable for all the tested samples. See ‘usage of samples’ paragraph of this report.

The target power alignments for RF components declared by the manufacturer for each technology supported are:

1. Bluetooth low energy

Protocol	Declared Target Power					
	Power Class	Peak Max. Power (dBm)	Average Max. Power (dBm)	Tuning tolerance (dB)	Max. Peak Output Power (dBm)	Max. Averaged Output Power (dBm)
Bluetooth low energy	1	5	2.8	+1/-2	6	3.8

2. GPRS

Protocol	Declared Target alignment for Low, Mid, High channels						
	Power Class	Power level (dBm)	1 Tx (dBm)	2 Tx (dBm)	Tuning Tolerance (dB)	Max Output Power 1 TX (dBm)	Max Output Power 2 TX (dBm)
GSM850 Primary mode	4	32.5	32.5	30.5	+1/-2	33.5	31.5
EGSM900 Primary mode	4	32.5	32.5	30.5	+1/-2	33.5	31.5
GSM1800 Primary mode	1	29.5	29.5	27.5	+1/-2	30.5	28.5
GSM1900 Primary mode	1	29.5	29.5	27.5	+1/-2	30.5	28.5

3. WLAN

Mode	Maximum Declared Tx Power (dBm)					Tuning Tolerance (dB)	Max Output Power (dBm)
	Ch 1	Ch 2	Ch 6	Ch 10	Ch 11		
802.11b DSSS 1 Mbps	18.0	18.0	18.0	18.0	18.0	+1/-2	19.0
802.11g OFDM 6 Mbps	16.0	17.0	17.0	17.0	16.0	+1/-2	18.0

1.4. DUT and test-site configurations

The DUT supports the following modes and frequency bands: GPRS 850/1900 MHz, Wi-Fi 802.11 b/g (2450 MHz) and Bluetooth LE (2450 MHz).

The DUT was placed with each face against the flat phantom surface, the separation distance between DUT and flat phantom surface was 15 mm for body worn exposure testing.

2. CONDUCTED AVERAGE POWER MEASUREMENTS

2.1. GPRS Bands

- GPRS 850: For data mode. PCL 5, CS1 coding scheme and Gamma 3 were set in the CMU-200 to allow DUT's max power transmission for each slot.

GPRS 850 - Frame Average Output Power							
Channel Number	Frequency (MHz)	Power (dBm) 1 Slot	Power (dBm) 2 Slot	Power (dBm) 3 Slot	Power (dBm) 4 Slot	PCL	Modulation
128	824.2	22.6	24.3	--	--	5	GMSK-CS1
190	836.6	22.5	24.2	--	--	5	GMSK-CS1
251	848.8	22.3	24.1	--	--	5	GMSK-CS1

GPRS 850 - Average Burst Output Power							
Channel Number	Frequency (MHz)	Power (dBm) 1 Slot	Power (dBm) 2 Slot	Power (dBm) 3 Slot	Power (dBm) 4 Slot	PCL	Modulation
128	824.2	31.6	30.3	--	--	5	GMSK-CS1
190	836.6	31.5	30.2	--	--	5	GMSK-CS1
251	848.8	31.4	30.1	--	--	5	GMSK-CS1

- GPRS1900: For data mode. PCL 0, CS1 coding scheme and Gamma 3 were set in the CMU-200 to allow max power transmission for each slot.

GPRS 1900 - Frame Average Output Power							
Channel Number	Frequency (MHz)	Power (dBm) 1 Slot	Power (dBm) 2 Slot	Power (dBm) 3 Slot	Power (dBm) 4 Slot	PCL	Modulation
512	1850.2	19.9	21.3	--	--	0	GMSK-CS1
661	1880	19.9	21.3	--	--	0	GMSK-CS1
810	1909.8	19.7	21.0	--	--	0	GMSK-CS1

GPRS 1900 - Average Burst Output Power							
Channel Number	Frequency (MHz)	Power (dBm) 1 Slot	Power (dBm) 2 Slot	Power (dBm) 3 Slot	Power (dBm) 4 Slot	PCL	Modulation
512	1850.2	28.9	27.3	--	--	0	GMSK-CS1
661	1880	28.9	27.3	--	--	0	GMSK-CS1
810	1909.8	28.7	27.0	--	--	0	GMSK-CS1

2.2. Wi-Fi & Bluetooth

- 2.4 GHz Band:

Band	Mode	Channel / Freq (MHz)	Averaged Power (dBm)
2.4 GHz	802.11b	1 / 2412	18.27
		2 / 2417	18.25
		3 / 2422	18.31
		4 / 2427	18.34
		5 / 2432	18.22
		6 / 2437	18.35
		7 / 2442	18.27
		8 / 2447	18.12
		9 / 2452	18.14
		10 / 2457	18.11
		11 / 2462	18.03
	802.11g	1 / 2412	15.89
		2 / 2417	16.79
		3 / 2422	16.85
		4 / 2427	16.80
		5 / 2432	16.81
		6 / 2437	16.78
		7 / 2442	16.73
		8 / 2447	16.68
		9 / 2452	16.74
		10 / 2457	16.63
		11 / 2462	15.61

Band	Mode	Freq (MHz)	Peak Power (dBm)	Averaged Power (dBm)
2.4 GHz	GFSK	2402	4.729	2.51
		2441	4.765	2.55
		2480	4.460	2.24

Based on the paragraph “4.3.1. Standalone SAR test exclusion considerations” of the KDB 447498 D01 - General RF Exposure Guidance v05r02:

$$\left[\frac{\text{max. power of channel, including tune-up tolerance, mW}}{\text{min. test separation distance, mm}} \right] \cdot [\sqrt{f(\text{GHz})}] \leq 3.0 \text{ for 1-g SAR and } \leq 7.5 \text{ for 10-g extremity SAR}$$

Communication System	Max Avg. Conducted output power+Tune-up		Min. Test separation distance (mm)	Frequency (Ghz)	Result	Test Exclusion
	(dBm)	(mW)				
Bluetooth LE	3.55	2.26	15	2441	0.23	√

The computed value for Bluetooth is < 3.0, so Bluetooth mode qualifies for Standalone SAR test exclusion for 1-g SAR and 10-g

When standalone SAR test exclusion applies to an antenna that transmits simultaneously with other antennas, the standalone SAR must be estimated according to following to determine simultaneous transmission SAR test exclusion:

$$\left[\frac{\text{max. power of channel, including tune-up tolerance, mW}}{\text{min. test separation distance, mm}} \right] \cdot [\sqrt{f(\text{GHz})/x}] \text{ W/kg for test separation distances } \leq 50 \text{ mm; where } x = 7.5 \text{ for 1-g SAR and } x = 18,75 \text{ for 10-g extremity SAR,}$$

Estimated SAR						
Communication System	Max. Avg. Conducted output power+Tune-up		Min. Test separation distance (mm)	Frequency (Ghz)	Estimated 1-g SAR	Estimated 10-g SAR
	(dBm)	(mW)				
Bluetooth LE	3.55	2.26	15	2441	0.0314	0.0126

According to IC RSS-102 Issue 5 (2015-03) – Radio Frequency Exposure Compliance of Radiocommunication Apparatus (All Frequency Bands), paragraph 2.5.1 Exemption Limits for Routine Evaluation – SAR Evaluation, the device operates below the applicable output power level (adjusted for tune-up tolerance) for the specified separation distance defined in Table 1:

Maximum Bluetooth output power level, Pmax= 2.26 mW < 15mW (Exemption limit at 2450MHz frequency, 15 mm distance)

Additionally SAR test exclusion threshold conditions will be checked using the declared maximum output power per tune-up procedure value for Bluetooth:

$$\left[\frac{\text{max. power of channel, including tune-up tolerance, mW}}{\text{min. test separation distance, mm}} \right] \cdot [\sqrt{f(\text{GHz})}] \leq 3.0 \text{ for 1-g SAR and } \leq 7.5 \text{ for 10-g extremity SAR}$$

Communication System	Max Averaged output power		Min. Test separation distance (mm)	Frequency (Ghz)	Result	Test Exclusion
	(dBm)	(mW)				
Bluetooth LE	3.80	2.40	15	2441	0.25	√

The computed value for Bluetooth is < 3.0, so Bluetooth mode qualifies for Standalone SAR test exclusion for 1-g SAR and 10-g

$$\left(\frac{\text{max. power of channel, including tune-up tolerance, mW}}{\text{min. test separation distance, mm}} \right) \cdot [\sqrt{f(\text{GHz})/x}] \text{ W/kg for test separation distances } \leq 50 \text{ mm; where } x = 7.5 \text{ for 1-g SAR and } x = 18,75 \text{ for 10-g extremity SAR,}$$

Estimated SAR						
Communication System	Max Averaged output power		Min. Test separation distance (mm)	Frequency (Ghz)	Estimated 1-g SAR	Estimated 10-g SAR
	(dBm)	(mW)				
Bluetooth LE	3.80	2.40	15	2441	0.0333	0.0126

According to IC RSS-102 Issue 5 (2015-03) – Radio Frequency Exposure Compliance of Radiocommunication Apparatus (All Frequency Bands), paragraph 2.5.1 Exemption Limits for Routine Evaluation – SAR Evaluation, the device operates below the applicable output power level (adjusted for tune-up tolerance) for the specified separation distance defined in Table 1:

Maximum Bluetooth output power level, Pmax= 2.40 mW < 15mW (Exemption limit at 2450 MHz frequency, 15 mm distance)

The worst case of these estimations will be used to calculate the 1g body simultaneous multi-band transmission value.

3. TISSUE PARAMETERS MEASUREMENTS

Frequency (MHz)	Target Body Tissue: Parameters used in Probe Calibration		Target Body Tissue: Parameters used in Dipole Calibration		Measured Body Tissue		Measured Date
	Permittivity	Conductivity [S/m]	Permittivity	Conductivity [S/m]	Permittivity	Conductivity [S/m]	
835	55.2 ± 5%	0.97 ± 5%	-	-	54.16 ± 5%	0.94 ± 5%	2015-06-11
900	55.0 ± 5%	1.05 ± 5%	54.8 ± 6%	1.03 ± 6%	53.48 ± 5%	1.01 ± 5%	2015-06-11
1800	53.3 ± 5%	1.52 ± 5%	51.4 ± 6%	1.53 ± 6%	53.11 ± 5%	1.45 ± 5%	2015-06-11
2450	52.7 ± 5%	1.95 ± 5%	50.5 ± 6%	2.01 ± 6%	51.35 ± 5%	2.00 ± 5%	2015-06-11

Note: The dielectric properties have been measured by the contact probe method at 23° C.

- Composition / Information on ingredients

Head and Muscle Tissue Simulation Liquids HSL900/MSL900

H ₂ O	Water, 35 – 58%
Sucrose	Sugar, white, refined, 40 – 60%
NaCl	Sodium Chloride, 0 – 6%
Hydroxyethyl-cellulose	Medium Viscosity (CAS# 9004-62-0), <0.3%
Preventol-D7	Preservative: aqueous preparation, (CAS# 55965-84-9), containing 5-chloro-2-methyl-3(2H)-isothiazolone and 2-methyl-3(2H)-isothiazolone, 0.1 – 0.7%

Head and Muscle Tissue Simulation Liquids HSL1800/MSL1800

H ₂ O	Water, 52 – 75%
C ₈ H ₁₈ O ₃	Diethylene glycol monobutyl ether (DGBE), 25 – 48% (CAS-No. 112-34-5, EC-No. 203-961-6, EC-index-No. 603-096-00-8)
NaCl	Sodium Chloride, <1.0%

Head and Muscle Tissue Simulation Liquids HBBL1900-3800V3/M HBBL1900-3800V3

Water	50 – 73 %
Non-ionic detergents	27 – 50 % polyoxyethylenesorbitan monolaurate
NaCl	0 – 2 %
Preservative	0.05 – 0.1% Preventol-D7
Safety relevant ingredients:	
CAS-No. 55965-84-9	< 0.1 % aqueous preparation, containing 5-chloro-2-methyl-3(2H)-isothiazolone and 2-methyl-3(2H)-isothiazolone
CAS-No. 9005-64-5	<50 % polyoxyethylenesorbitan monolaurate

4. SYSTEM CHECK MEASUREMENTS

Frequency (MHz)	Date	SAR	Target SAR	Measured SAR	Drift (%)	Limit (%)
900	11-06-2015	1 gr.	10.70	11.18	4.45	10
		10 gr.	6.95	7.29	4.93	10
1800	11-06-2015	1 gr.	39.50	40.59	2.75	10
		10 gr.	21.00	22.18	5.63	10
2450	11-06-2015	1 gr.	51.10	53.57	4.83	10
		10 gr.	23.90	24.72	3.43	10

5. MEASUREMENT RESULTS FOR SAR (SPECIFIC ABSORPTION RATE)

5.1. Summary maximum results for 1-g body SAR measurements.

Band	Mode	Side / Position	Channel (Frequency)	Reported SAR (1g avg) (W/Kg)	SAR limit (1g avg) (W/Kg)
850 MHz	GPRS 2 slots	Front face / 15 mm	CH 128 (824.2 Mhz)	1.397	1.6
1900 MHz	GPRS 2 slots	Front face / 15 mm	CH 661 (1880 Mhz)	0.592	1.6
2450 MHz	802.11b	Front face / 15 mm	CH 6 (2437 Mhz)	0.118	1.6

5.2. Result for 1g body simultaneous multi-band transmission

Transmission Mode	Band	Max SAR (1g avg) (W/Kg)	Σ SARi (W/kg)	SAR limit (W/Kg)	Verdict
GPRS	850MHz	1.397	1.548	1.6	Pass
802.11b	2.45 GHz	0.118			
Bluetooth LE (Estimated)	2.45 GHz	0.033			
GPRS	1900MHz	0.592	0.743	1.6	Pass
802.11b	2.45 GHz	0.118			
Bluetooth LE (Estimated)	2.45 GHz	0.033			

5.3. Results for GPRS 850 MHz band – 2 slots.

Side / Position	Dist (mm)	Channel (Frequency)	1-g SAR (W/Kg)	Power Drift (%)	Max Output Power (dBm)	Max. Reported 1-g SAR	Plot No.
Front face	15	CH 190 (836.6 Mhz)	1.02	-0.23	31.5	1.376	
Back face	15	CH 190 (836.6 Mhz)	0.713	-0.34	31.5	0.962	
Front face	15	CH 128 (824.2 Mhz)	1.06	0	31.5	1.397	1
Front face	15	CH 251 (848.8 Mhz)	0.992	0.12	31.5	1369	
Front Face/ Variability	15	CH 128 (824.2 Mhz)	1.06	0	31.5	1.397	2

5.4. Results for GPRS 1900 MHz Band – 2 slots.

Side / Position	Dist (mm)	Channel (Frequency)	1-g SAR (W/Kg)	Power Drift (%)	Max Output Power (dBm)	Max. Reported 1-g SAR	Plot No.
Front face	15	CH 661 (1880 Mhz)	0.449	0.23	28.5	0.592	3
Back face	15	CH 661 (1880 Mhz)	0.298	0.35	28.5	0.393	
Front face	15	CH 512 (1850.2 Mhz)	NM ¹		28.5		
Front face	15	CH 810 (1909.8 Mhz)	NM ¹		28.5		

1: See remarks and comments.

5.5. Results for Wi-Fi 2450 MHz Band.

- 802.11 b

Side / Position	Dist (mm)	Mode	Ch #. (Freq)	1-g SAR (W/Kg)	Power Drift (%)	Max Output Power (dBm)	Max. Reported 1-g SAR	Plot No.
Front face	15	802.11b	CH 6 (2437 Mhz)	0.102	1.98	19	0.118	4
Back face	15	802.11b	CH 6 (2437 Mhz)	0.091	0.23	19	0.106	
Back face	15	802.11b	CH 1 (2412 Mhz)	NM ¹		19		
Back face	15	802.11b	CH 11 (2462 Mhz)	NM ¹		19		

1: See remarks and comments

- 802.11 g

Highest reported SAR in 802.11b mode and exposure condition for 2450 MHz band is 0.118 W/Kg.

802.11 b Max declared Power = 19 dBm → 79.43 mW

802.11 g Max declared Power = 18 dBm → 63.10 mW

Adjusted SAR for 802.11g:

$$0.118 \text{ W/Kg} \times (63.10/79.43) = 0.094 \text{ W/Kg}$$

As Adjusted SAR for 802.11g ≤ 1.2 W/Kg, SAR measurements are not required for 802.11g.

Appendix C – Measurement report

GPRS 850 MHz 2 slots – Body – Front Face, d=15 mm – Lowest Channel – Plot N° 1

Test Laboratory: AT4 Wireless; Date: 11/06/2015

DUT: Thingseeone; Type: --; Serial: IMEI: 353816057441398

Communication System: UID 10024 - DAB, GPRS-FDD (TDMA, GMSK, TN 0-1); Frequency: 824.2 MHz; Duty Cycle: 1:4.52898

Medium parameters used (extrapolated): $f = 824.2$ MHz; $\sigma = 0.927$ S/m; $\epsilon_r = 54.274$; $\rho = 1000$ kg/m³

Phantom section: Flat Section

DASY5 Configuration:

- Probe: ES3DV3 - SN3052; ConvF(6.26, 6.26, 6.26); Calibrated: 24/09/2014;
- Sensor-Surface: 3mm (Mechanical Surface Detection (Locations From Previous Scan Used)), Sensor-Surface: 4mm (Mechanical Surface Detection)
- Electronics: DAE4 Sn669; Calibrated: 08/07/2014
- Phantom: Flat Phantom ELI4.0; Type: QDOVA001BA; Serial: SN:1060
- Measurement SW: DASY52, Version 52.8 (8); SEMCAD X Version 14.6.10 (7331)

Flat Phantom Side - 850 MHz/GPRS 850, 2 slots, Low CH, Front face, d=15mm/Area Scan (91x131x1):

Interpolated grid: dx=1.000 mm, dy=1.000 mm

Info: [Extrapolated medium parameters used for SAR evaluation.](#)

Maximum value of SAR (interpolated) = 1.18 W/kg

Flat Phantom Side - 850 MHz/GPRS 850, 2 slots, Low CH, Front face, d=15mm/Zoom Scan (7x7x7)/Cube 0:

Measurement grid: dx=5mm, dy=5mm, dz=5mm

Reference Value = 34.15 V/m; Power Drift = 0.00 dB

Peak SAR (extrapolated) = 1.37 W/kg

SAR(1 g) = 1.06 W/kg; SAR(10 g) = 0.761 W/kg (SAR corrected for target medium)

Info: [Extrapolated medium parameters used for SAR evaluation.](#)

Maximum value of SAR (measured) = 1.10 W/kg

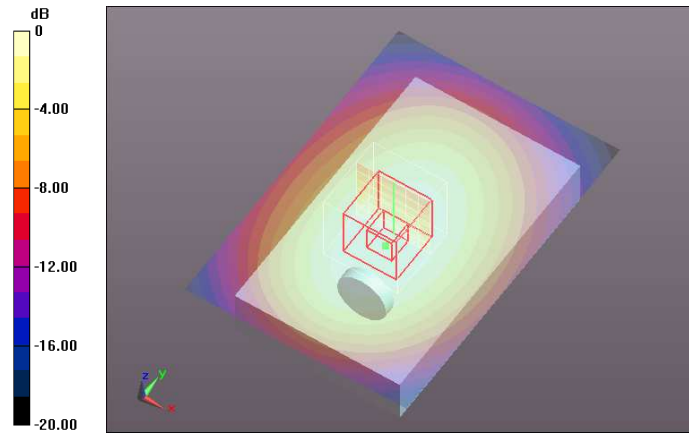

0 dB = 1.10 W/kg = 0.41 dBW/kg

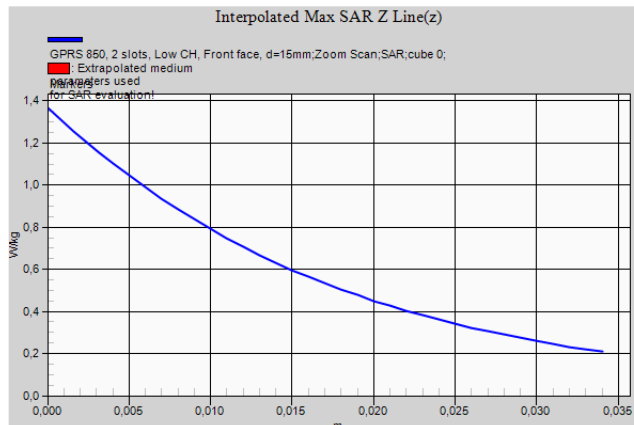

GPRS 850 MHz 2 slots – Body – Front Face, d=15 mm – Lowest Channel – Variability – Plot N° 2

Test Laboratory: AT4 Wireless; Date: 11/06/2015

DUT: Thingseone; Type: --; Serial: IMEI:353816057441398

Communication System: UID 10024 - DAB, GPRS-FDD (TDMA, GMSK, TN 0-1); Frequency: 824.2 MHz; Duty Cycle: 1:4.52898

Medium parameters used (extrapolated): $f = 824.2$ MHz; $\sigma = 0.927$ S/m; $\epsilon_r = 54.274$; $\rho = 1000$ kg/m³

Phantom section: Flat Section

DASY5 Configuration:

- Probe: ES3DV3 - SN3052; ConvF(6.26, 6.26, 6.26); Calibrated: 24/09/2014;
- Sensor-Surface: 3mm (Mechanical Surface Detection (Locations From Previous Scan Used)), Sensor-Surface: 4mm (Mechanical Surface Detection)
- Electronics: DAE4 Sn669; Calibrated: 08/07/2014
- Phantom: Flat Phantom ELI4.0; Type: QDOVA001BA; Serial: SN:1060
- Measurement SW: DASY52, Version 52.8 (8); SEMCAD X Version 14.6.10 (7331)

Flat Phantom Side - 850 MHz/GPRS 850, 2 slots, Low CH, Front face, d=15mm Variability/Area Scan (91x131x1):

Interpolated grid: dx=1.000 mm, dy=1.000 mm

Info: [Extrapolated medium parameters used for SAR evaluation.](#)

Maximum value of SAR (interpolated) = 1.18 W/kg

Flat Phantom Side - 850 MHz/GPRS 850, 2 slots, Low CH, Front face, d=15mm Variability/Zoom Scan (7x7x7)/Cube 0:

Measurement grid: dx=5mm, dy=5mm, dz=5mm

Reference Value = 34.14 V/m; Power Drift = 0.00 dB

Peak SAR (extrapolated) = 1.35 W/kg

SAR(1 g) = 1.06 W/kg; SAR(10 g) = 0.759 W/kg (SAR corrected for target medium)

Info: [Extrapolated medium parameters used for SAR evaluation.](#)

Maximum value of SAR (measured) = 1.10 W/kg

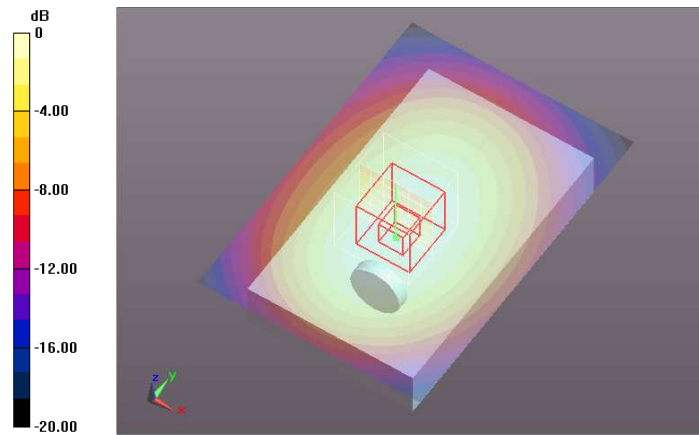

0 dB = 1.10 W/kg = 0.41 dBW/kg

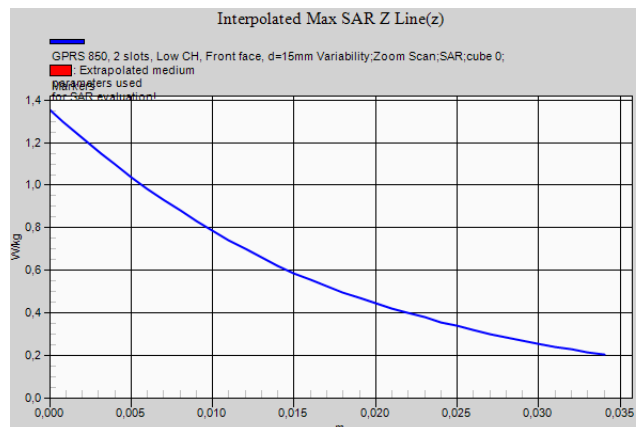

GPRS 1900 MHz 2 slots – Body – Front Face, d=15 mm – Middle Channel - Plot N° 3

Test Laboratory: AT4 Wireless; Date: 11/06/2015

DUT: Thingseeone; Type: --; Serial: IMEI: 353816057441398

Communication System: UID 10024 - DAB, GPRS-FDD (TDMA, GMSK, TN 0-1); Frequency: 1880 MHz; Duty Cycle: 1:4.52898

Medium parameters used: $f = 1880$ MHz; $\sigma = 1.47$ S/m; $\epsilon_r = 52.9$; $\rho = 1000$ kg/m³

Phantom section: Flat Section

DASY5 Configuration:

- Probe: ES3DV3 - SN3052; ConvF(4.71, 4.71, 4.71); Calibrated: 24/09/2014;
- Sensor-Surface: 3mm (Mechanical Surface Detection (Locations From Previous Scan Used)), Sensor-Surface: 4mm (Mechanical Surface Detection)
- Electronics: DAE4 Sn669; Calibrated: 08/07/2014
- Phantom: Flat Phantom ELI4.0; Type: QDOVA001BA; Serial: SN:1060
- Measurement SW: DASY52, Version 52.8 (8); SEMCAD X Version 14.6.10 (7331)

Flat Phantom Side - 1900 MHz/GPRS 1900, 2 slots, Mid CH, Front face, d=15mm/Area Scan (91x131x1):

Interpolated grid: dx=1.000 mm, dy=1.000 mm

Maximum value of SAR (interpolated) = 0.517 W/kg

Flat Phantom Side - 1900 MHz/GPRS 1900, 2 slots, Mid CH, Front face, d=15mm/Zoom Scan (7x7x7)/Cube 0:

Measurement grid: dx=5mm, dy=5mm, dz=5mm

Reference Value = 15.94 V/m; Power Drift = 0.02 dB

Peak SAR (extrapolated) = 0.674 W/kg

SAR(1 g) = 0.449 W/kg; SAR(10 g) = 0.280 W/kg (SAR corrected for target medium)

Maximum value of SAR (measured) = 0.481 W/kg

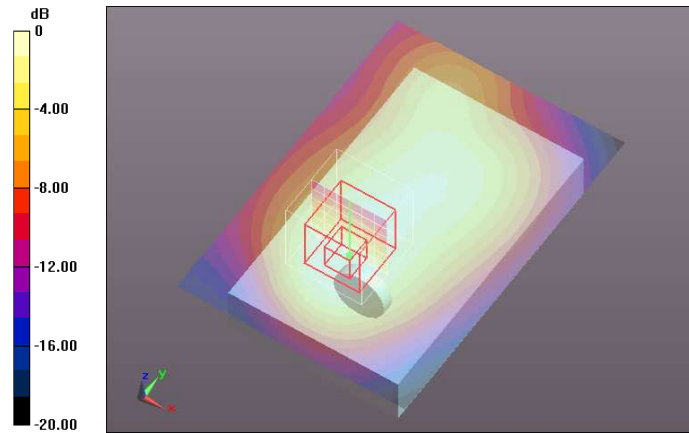

0 dB = 0.481 W/kg = -3.18 dBW/kg

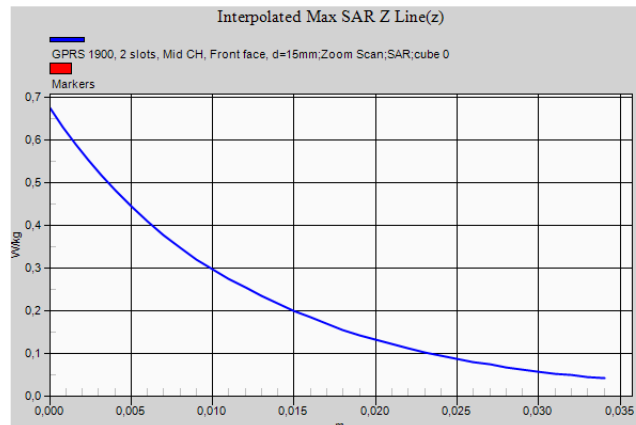

802.11b – 2450MHz –Body – Front Face, d=15 mm – Middle Channel – Plot N° 4

Test Laboratory: AT4 Wireless; Date: 11/06/2015

DUT: Thingseone; Type: --; Serial: IMEI:353816057444079

Communication System: UID 10012 - CAA, IEEE 802.11b WiFi 2.4 GHz (DSSS, 1 Mbps); Frequency: 2437 MHz; Duty Cycle: 1:1.53815

Medium parameters used (interpolated): $f = 2437 \text{ MHz}$; $\sigma = 1.987 \text{ S/m}$; $\epsilon_r = 51.363$; $\rho = 1000 \text{ kg/m}^3$

Phantom section: Flat Section

DASY5 Configuration:

- Probe: ES3DV3 - SN3052; ConvF(4.3, 4.3, 4.3); Calibrated: 24/09/2014;
- Sensor-Surface: 3mm (Mechanical Surface Detection (Locations From Previous Scan Used)), Sensor-Surface: 4mm (Mechanical Surface Detection)
- Electronics: DAE4 Sn669; Calibrated: 08/07/2014
- Phantom: Flat Phantom ELI4.0; Type: QDOVA001BA; Serial: SN:1060
- Measurement SW: DASY52, Version 52.8 (8); SEMCAD X Version 14.6.10 (7331)

Flat Phantom Side - 2.45 GHz/802.11b, CH 6, Front face, d=15mm/Area Scan (91x131x1):

Interpolated grid: $dx=1.000 \text{ mm}$, $dy=1.000 \text{ mm}$

Info: [Interpolated medium parameters used for SAR evaluation.](#)

Maximum value of SAR (interpolated) = 0.130 W/kg

Flat Phantom Side - 2.45 GHz/802.11b, CH 6, Front face, d=15mm/Zoom Scan (7x7x7)/Cube 0:

Measurement grid: $dx=5\text{mm}$, $dy=5\text{mm}$, $dz=5\text{mm}$

Reference Value = 7.171 V/m ; Power Drift = 0.17 dB

Peak SAR (extrapolated) = 0.186 W/kg

SAR(1 g) = 0.102 W/kg ; SAR(10 g) = 0.054 W/kg (SAR corrected for target medium)

Info: [Interpolated medium parameters used for SAR evaluation.](#)

Maximum value of SAR (measured) = 0.112 W/kg

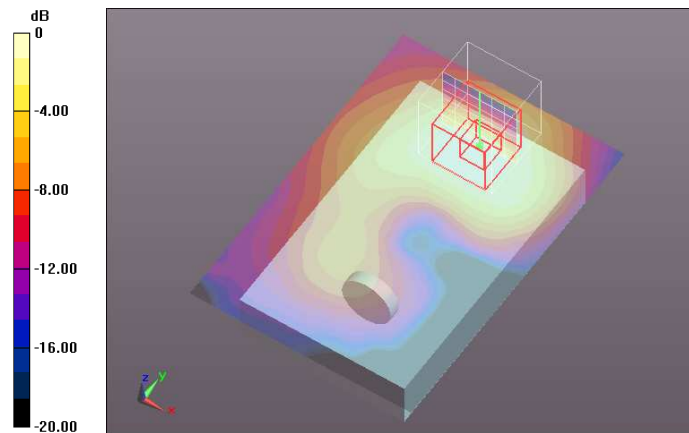

0 dB = 0.112 W/kg = -9.51 dBW/kg

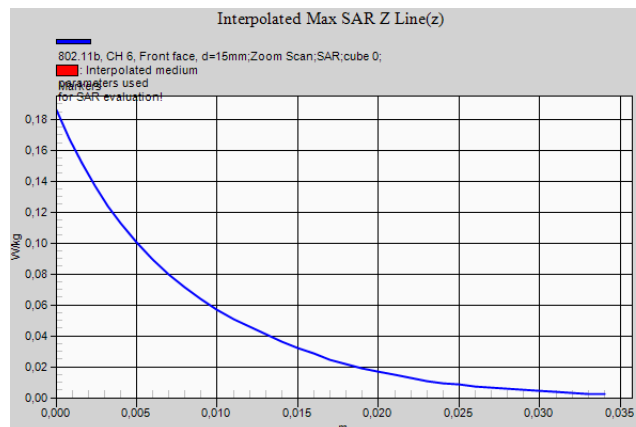

Appendix D – System Validation Reports

Validation results in 900 MHz Band for Body TSL

Test Laboratory: AT4 Wireless; Date: 11/06/2015

DUT: Dipole 900 MHz D900V2; Type: D900V2; Serial: D900V2 - SN:1d007

Communication System: UID 0, CW; Frequency: 900 MHz; Duty Cycle: 1:1

Medium parameters used: $f = 900$ MHz; $\sigma = 1.01$ S/m; $\epsilon_r = 53.48$; $\rho = 1000$ kg/m³

Phantom section: Flat Section

DASY5 Configuration:

- Probe: ES3DV3 - SN3052; ConvF(6.14, 6.14, 6.14); Calibrated: 24/09/2014;
- Sensor-Surface: 3mm (Mechanical Surface Detection)
- Electronics: DAE4 Sn669; Calibrated: 08/07/2014
- Phantom: Flat Phantom ELI4.0; Type: QDOVA001BA; Serial: SN:1060
- Measurement SW: DASY52, Version 52.8 (8); SEMCAD X Version 14.6.10 (7331)

Configuration 900MHz/d=15mm, Pin=250 mW/Area Scan (61x91x1):

Interpolated grid: dx=1.500 mm, dy=1.500 mm

Maximum value of SAR (interpolated) = 3.16 W/kg

Configuration 900MHz/d=15mm, Pin=250 mW/Zoom Scan (7x7x7)/Cube 0:

Measurement grid: dx=5mm, dy=5mm, dz=5mm

Reference Value = 57.47 V/m; Power Drift = 0.04 dB

Peak SAR (extrapolated) = 4.07 W/kg

SAR(1 g) = 2.82 W/kg; SAR(10 g) = 1.84 W/kg (SAR corrected for target medium)

Maximum value of SAR (measured) = 3.23 W/kg

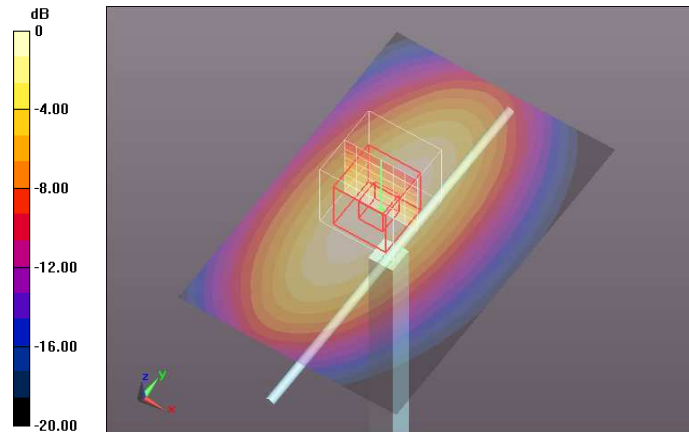

0 dB = 3.23 W/kg = 5.09 dBW/kg

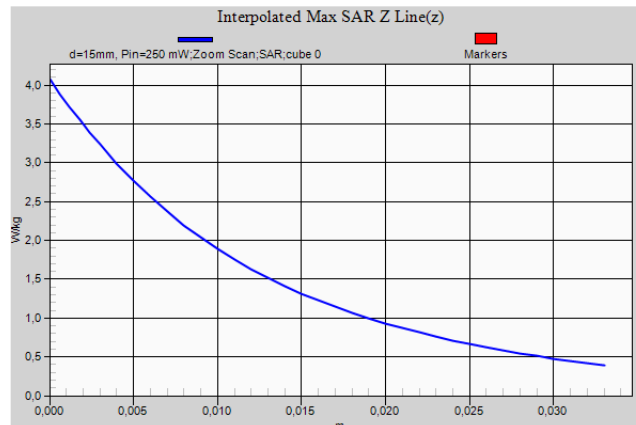

Validation results in 1800 MHz Band for Body TSL

Test Laboratory: AT4 Wireless; Date: 11/06/2015

DUT: Dipole 1800 MHz D1800V2; Type: D1800V2; Serial: D1800V2 - SN:2d099

Communication System: UID 0, CW (0); Frequency: 1800 MHz; Duty Cycle: 1:1

Medium parameters used: $f = 1800$ MHz; $\sigma = 1.45$ S/m; $\epsilon_r = 53.11$; $\rho = 1000$ kg/m³

Phantom section: Flat Section

DASY5 Configuration:

- Probe: ES3DV3 - SN3052; ConvF(4.94, 4.94, 4.94); Calibrated: 24/09/2014;
- Sensor-Surface: 3mm (Mechanical Surface Detection)
- Electronics: DAE4 Sn669; Calibrated: 08/07/2014
- Phantom: Flat Phantom ELI4.0; Type: QDOVA001BA; Serial: SN:1060
- Measurement SW: DASY52, Version 52.8 (8); SEMCAD X Version 14.6.10 (7331)

Configuration 1800 MHz/d=10mm, Pin=250 mW/Area Scan (91x91x1):

Interpolated grid: dx=1.000 mm, dy=1.000 mm

Maximum value of SAR (interpolated) = 12.5 W/kg

Configuration 1800 MHz/d=10mm, Pin=250 mW/Zoom Scan (7x7x7)/Cube 0:

Measurement grid: dx=5mm, dy=5mm, dz=5mm

Reference Value = 97.20 V/m; Power Drift = -0.12 dB

Peak SAR (extrapolated) = 16.5 W/kg

SAR(1 g) = 10.1 W/kg; SAR(10 g) = 5.52 W/kg (SAR corrected for target medium)

Maximum value of SAR (measured) = 12.4 W/kg

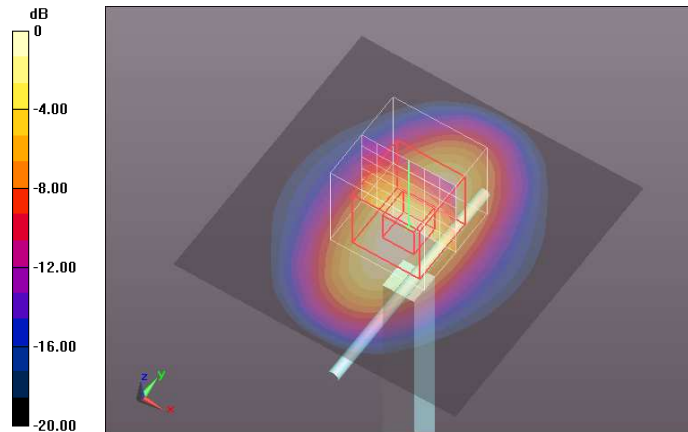

0 dB = 12.4 W/kg = 10.93 dBW/kg

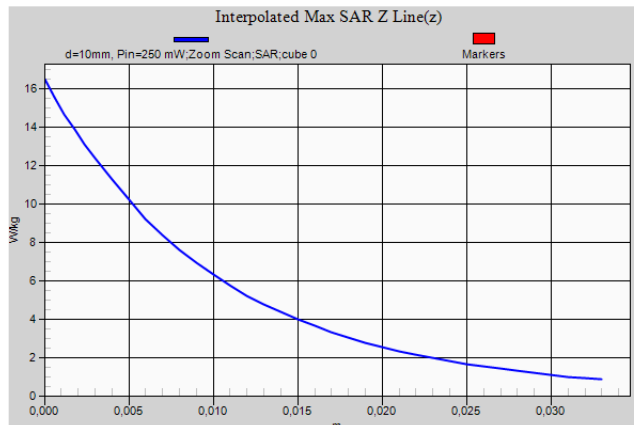

Validation results in 2450 MHz Band for Body TSL

Test Laboratory: AT4 Wireless; Date: 11/06/2015

DUT: Dipole 2450 MHz D2450V2; Type: D2450V2; Serial: D2450V2 - SN:756

Communication System: UID 0, CW (0); Frequency: 2450 MHz; Duty Cycle: 1:1

Medium parameters used: $f = 2450$ MHz; $\sigma = 2$ S/m; $\epsilon_r = 51.35$; $\rho = 1000$ kg/m³

Phantom section: Flat Section

DASY5 Configuration:

- Probe: ES3DV3 - SN3052; ConvF(4.3, 4.3, 4.3); Calibrated: 24/09/2014;
- Sensor-Surface: 3mm (Mechanical Surface Detection)
- Electronics: DAE4 Sn669; Calibrated: 08/07/2014
- Phantom: Flat Phantom ELI4.0; Type: QDOVA001BA; Serial: SN:1060
- Measurement SW: DASY52, Version 52.8 (8); SEMCAD X Version 14.6.10 (7331)

Configuration 2450 MHz/d=10mm, Pin=250 mW/Area Scan (91x91x1):

Interpolated grid: dx=1.000 mm, dy=1.000 mm

Maximum value of SAR (interpolated) = 18.1 W/kg

Configuration 2450 MHz/d=10mm, Pin=250 mW/Zoom Scan (7x7x7)/Cube 0:

Measurement grid: dx=5mm, dy=5mm, dz=5mm

Reference Value = 97.52 V/m; Power Drift = -0.07 dB

Peak SAR (extrapolated) = 28.2 W/kg

SAR(1 g) = 13.5 W/kg; SAR(10 g) = 6.23 W/kg (SAR corrected for target medium)

Maximum value of SAR (measured) = 17.8 W/kg

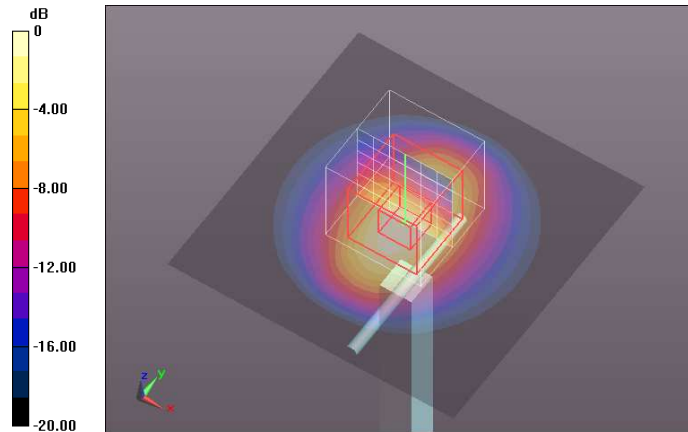

0 dB = 17.8 W/kg = 12.50 dBW/kg

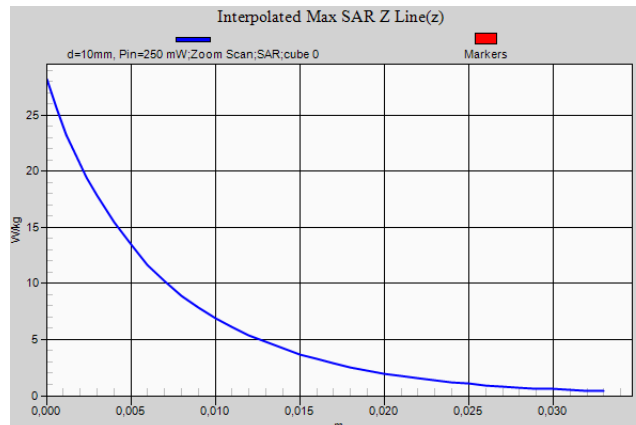

Appendix E – Calibration data

Calibration Laboratory of
Schmid & Partner
Engineering AG
 Zeughausstrasse 43, 8004 Zurich, Switzerland



S Schweizerischer Kalibrierdienst
C Service suisse d'étalonnage
S Servizio svizzero di taratura
S Swiss Calibration Service

Accredited by the Swiss Accreditation Service (SAS)
 The Swiss Accreditation Service is one of the signatories to the EA
 Multilateral Agreement for the recognition of calibration certificates

Accreditation No.: **SCS 108**

Client **AT4 Wireless**

Certificate No: **DAE4-669_Jul14**

CALIBRATION CERTIFICATE																							
Object	DAE4 - SD 000 D04 BM - SN: 669																						
Calibration procedure(s)	QA CAL-06.v26 Calibration procedure for the data acquisition electronics (DAE)																						
Calibration date:	July 08, 2014																						
<p>This calibration certificate documents the traceability to national standards, which realize the physical units of measurements (SI). The measurements and the uncertainties with confidence probability are given on the following pages and are part of the certificate.</p> <p>All calibrations have been conducted in the closed laboratory facility: environment temperature (22 ± 3)°C and humidity < 70%.</p> <p>Calibration Equipment used (M&TE critical for calibration)</p> <table border="1"> <thead> <tr> <th>Primary Standards</th> <th>ID #</th> <th>Cal Date (Certificate No.)</th> <th>Scheduled Calibration</th> </tr> </thead> <tbody> <tr> <td>Keithley Multimeter Type 2001</td> <td>SN: 0810278</td> <td>01-Oct-13 (No:13976)</td> <td>Oct-14</td> </tr> <tr> <th>Secondary Standards</th> <th>ID #</th> <th>Check Date (in house)</th> <th>Scheduled Check</th> </tr> <tr> <td>Auto DAE Calibration Unit</td> <td>SE UWS 053 AA 1001</td> <td>07-Jan-14 (in house check)</td> <td>In house check: Jan-15</td> </tr> <tr> <td>Calibrator Box V2.1</td> <td>SE UMS 006 AA 1002</td> <td>07-Jan-14 (in house check)</td> <td>In house check: Jan-15</td> </tr> </tbody> </table>				Primary Standards	ID #	Cal Date (Certificate No.)	Scheduled Calibration	Keithley Multimeter Type 2001	SN: 0810278	01-Oct-13 (No:13976)	Oct-14	Secondary Standards	ID #	Check Date (in house)	Scheduled Check	Auto DAE Calibration Unit	SE UWS 053 AA 1001	07-Jan-14 (in house check)	In house check: Jan-15	Calibrator Box V2.1	SE UMS 006 AA 1002	07-Jan-14 (in house check)	In house check: Jan-15
Primary Standards	ID #	Cal Date (Certificate No.)	Scheduled Calibration																				
Keithley Multimeter Type 2001	SN: 0810278	01-Oct-13 (No:13976)	Oct-14																				
Secondary Standards	ID #	Check Date (in house)	Scheduled Check																				
Auto DAE Calibration Unit	SE UWS 053 AA 1001	07-Jan-14 (in house check)	In house check: Jan-15																				
Calibrator Box V2.1	SE UMS 006 AA 1002	07-Jan-14 (in house check)	In house check: Jan-15																				
Calibrated by:	Name Dominique Steffen	Function Technician	Signature 																				
Approved by:	Fin Bornholt	Deputy Technical Manager																					
			Issued: July 8, 2014																				
This calibration certificate shall not be reproduced except in full without written approval of the laboratory.																							

Calibration Laboratory of
Schmid & Partner
Engineering AG
Zeughausstrasse 43, 8004 Zurich, Switzerland



S Schweizerischer Kalibrierdienst
C Service suisse d'étalonnage
S Servizio svizzero di taratura
S Swiss Calibration Service

Accredited by the Swiss Accreditation Service (SAS)
The Swiss Accreditation Service is one of the signatories to the EA
Multilateral Agreement for the recognition of calibration certificates

Accreditation No.: **SCS 108**

Glossary

DAE data acquisition electronics
Connector angle information used in DASY system to align probe sensor X to the robot coordinate system.

Methods Applied and Interpretation of Parameters

- *DC Voltage Measurement*: Calibration Factor assessed for use in DASY system by comparison with a calibrated instrument traceable to national standards. The figure given corresponds to the full scale range of the voltmeter in the respective range.
- *Connector angle*: The angle of the connector is assessed measuring the angle mechanically by a tool inserted. Uncertainty is not required.
- The following parameters as documented in the Appendix contain technical information as a result from the performance test and require no uncertainty.
 - *DC Voltage Measurement Linearity*: Verification of the Linearity at +10% and -10% of the nominal calibration voltage. Influence of offset voltage is included in this measurement.
 - *Common mode sensitivity*: Influence of a positive or negative common mode voltage on the differential measurement.
 - *Channel separation*: Influence of a voltage on the neighbor channels not subject to an input voltage.
 - *AD Converter Values with inputs shorted*: Values on the internal AD converter corresponding to zero input voltage
 - *Input Offset Measurement*: Output voltage and statistical results over a large number of zero voltage measurements.
 - *Input Offset Current*: Typical value for information; Maximum channel input offset current, not considering the input resistance.
 - *Input resistance*: Typical value for information: DAE input resistance at the connector, during internal auto-zeroing and during measurement.
 - *Low Battery Alarm Voltage*: Typical value for information. Below this voltage, a battery alarm signal is generated.
 - *Power consumption*: Typical value for information. Supply currents in various operating modes.

DC Voltage Measurement

A/D - Converter Resolution nominal

High Range: 1LSB = 6.1 μ V, full range = -100...+300 mV

Low Range: 1LSB = 61nV, full range = -1.....+3mV

DASY measurement parameters: Auto Zero Time: 3 sec; Measuring time: 3 sec

Calibration Factors	X	Y	Z
High Range	403.321 \pm 0.02% (k=2)	403.870 \pm 0.02% (k=2)	404.236 \pm 0.02% (k=2)
Low Range	3.95654 \pm 1.50% (k=2)	3.97463 \pm 1.50% (k=2)	3.97450 \pm 1.50% (k=2)

Connector Angle

Connector Angle to be used in DASY system	193.0 $^{\circ}$ \pm 1 $^{\circ}$
---	-------------------------------------

Appendix (Additional assessments outside the scope of SCS108)

1. DC Voltage Linearity

High Range	Reading (μV)	Difference (μV)	Error (%)
Channel X + Input	199998.19	1.59	0.00
Channel X + Input	20005.64	5.16	0.03
Channel X - Input	-19996.31	4.81	-0.02
Channel Y + Input	199995.73	-1.00	-0.00
Channel Y + Input	20004.06	3.54	0.02
Channel Y - Input	-19997.93	3.28	-0.02
Channel Z + Input	199997.38	0.79	0.00
Channel Z + Input	20004.17	3.55	0.02
Channel Z - Input	-19997.90	3.31	-0.02

Low Range	Reading (μV)	Difference (μV)	Error (%)
Channel X + Input	2000.84	0.28	0.01
Channel X + Input	201.50	0.42	0.21
Channel X - Input	-197.83	0.90	-0.45
Channel Y + Input	2001.06	0.57	0.03
Channel Y + Input	200.71	-0.32	-0.16
Channel Y - Input	-199.39	-0.60	0.30
Channel Z + Input	2001.12	0.68	0.03
Channel Z + Input	199.84	-1.25	-0.62
Channel Z - Input	-200.65	-1.79	0.90

2. Common mode sensitivity

DASY measurement parameters: Auto Zero Time: 3 sec; Measuring time: 3 sec

	Common mode Input Voltage (mV)	High Range Average Reading (μV)	Low Range Average Reading (μV)
Channel X	200	2.02	0.88
	- 200	1.03	-0.74
Channel Y	200	11.55	10.93
	- 200	-12.37	-12.38
Channel Z	200	-9.56	-9.90
	- 200	8.49	8.06

3. Channel separation

DASY measurement parameters: Auto Zero Time: 3 sec; Measuring time: 3 sec

	Input Voltage (mV)	Channel X (μV)	Channel Y (μV)	Channel Z (μV)
Channel X	200	-	-2.27	-2.78
Channel Y	200	9.49	-	-1.75
Channel Z	200	3.99	7.50	-

4. AD-Converter Values with inputs shorted

DASY measurement parameters: Auto Zero Time: 3 sec; Measuring time: 3 sec

	High Range (LSB)	Low Range (LSB)
Channel X	16079	16148
Channel Y	15795	15263
Channel Z	15997	15243

5. Input Offset Measurement

DASY measurement parameters: Auto Zero Time: 3 sec; Measuring time: 3 sec

Input 10M Ω

	Average (μ V)	min. Offset (μ V)	max. Offset (μ V)	Std. Deviation (μ V)
Channel X	0.48	-0.54	1.65	0.44
Channel Y	-0.35	-1.84	1.53	0.54
Channel Z	0.15	-1.16	0.99	0.42

6. Input Offset Current

Nominal Input circuitry offset current on all channels: <25fA

7. Input Resistance (Typical values for information)

	Zeroing (kOhm)	Measuring (MOhm)
Channel X	200	200
Channel Y	200	200
Channel Z	200	200

8. Low Battery Alarm Voltage (Typical values for information)

Typical values	Alarm Level (VDC)
Supply (+ Vcc)	+7.9
Supply (- Vcc)	-7.6

9. Power Consumption (Typical values for information)

Typical values	Switched off (mA)	Stand by (mA)	Transmitting (mA)
Supply (+ Vcc)	+0.01	+6	+14
Supply (- Vcc)	-0.01	-8	-9

**Calibration Laboratory of
 Schmid & Partner
 Engineering AG**
 Zeughausstrasse 43, 8004 Zurich, Switzerland



S Schweizerischer Kalibrierdienst
S Service suisse d'étalonnage
S Servizio svizzero di taratura
S Swiss Calibration Service

Accredited by the Swiss Accreditation Service (SAS)
 The Swiss Accreditation Service is one of the signatories to the EA
 Multilateral Agreement for the recognition of calibration certificates

Accreditation No.: **SCS 108**

Client **AT4 Wireless**

Certificate No: **ES3-3052_Sep14**

CALIBRATION CERTIFICATE

Object **ES3DV3 - SN:3052**

Calibration procedure(s) **QA CAL-01.v9, QA CAL-23.v5, QA CAL-25.v6
 Calibration procedure for dosimetric E-field probes**



Calibration date: **September 24, 2014**

This calibration certificate documents the traceability to national standards, which realize the physical units of measurements (SI).
 The measurements and the uncertainties with confidence probability are given on the following pages and are part of the certificate.

All calibrations have been conducted in the closed laboratory facility: environment temperature (22 ± 3)°C and humidity < 70%.

Calibration Equipment used (M&TE critical for calibration)

Primary Standards	ID	Cal Date (Certificate No.)	Scheduled Calibration
Power meter E4419B	GB41293874	03-Apr-14 (No. 217-01911)	Apr-15
Power sensor E4412A	MY41498087	03-Apr-14 (No. 217-01911)	Apr-15
Reference 3 dB Attenuator	SN: S5054 (3c)	03-Apr-14 (No. 217-01915)	Apr-15
Reference 20 dB Attenuator	SN: S5277 (20x)	03-Apr-14 (No. 217-01919)	Apr-15
Reference 30 dB Attenuator	SN: S5129 (30b)	03-Apr-14 (No. 217-01920)	Apr-15
Reference Probe ES3DV2	SN: 3013	30-Dec-13 (No. ES3-3013_Dec13)	Dec-14
DAE4	SN: 660	13-Dec-13 (No. DAE4-660_Dec13)	Dec-14
Secondary Standards	ID	Check Date (in house)	Scheduled Check
RF generator HP 8648C	US3642U01700	4-Aug-99 (in house check Apr-13)	In house check: Apr-16
Network Analyzer HP 8753E	US37390585	18-Oct-01 (in house check Oct-13)	In house check: Oct-14

Calibrated by:	Name Leif Klysner	Function Laboratory Technician	Signature 
Approved by:	Name Katja Pokovic	Function Technical Manager	Signature 

Issued: September 24, 2014

This calibration certificate shall not be reproduced except in full without written approval of the laboratory.

**Calibration Laboratory of
 Schmid & Partner
 Engineering AG**
 Zeughausstrasse 43, 8004 Zurich, Switzerland



S Schweizerischer Kalibrierdienst
C Service suisse d'étalonnage
S Servizio svizzero di taratura
S Swiss Calibration Service

Accredited by the Swiss Accreditation Service (SAS)
 The Swiss Accreditation Service is one of the signatories to the EA
 Multilateral Agreement for the recognition of calibration certificates

Accreditation No.: **SCS 108**

Glossary:

TSL	tissue simulating liquid
NORM _{x,y,z}	sensitivity in free space
ConvF	sensitivity in TSL / NORM _{x,y,z}
DCP	diode compression point
CF	crest factor (1/duty_cycle) of the RF signal
A, B, C, D	modulation dependent linearization parameters
Polarization φ	φ rotation around probe axis
Polarization ϑ	ϑ rotation around an axis that is in the plane normal to probe axis (at measurement center), i.e., $\vartheta = 0$ is normal to probe axis
Connector Angle	information used in DASY system to align probe sensor X to the robot coordinate system

Calibration is Performed According to the Following Standards:

- a) IEEE Std 1528-2013, "IEEE Recommended Practice for Determining the Peak Spatial-Averaged Specific Absorption Rate (SAR) in the Human Head from Wireless Communications Devices: Measurement Techniques", June 2013
- b) IEC 62209-1, "Procedure to measure the Specific Absorption Rate (SAR) for hand-held devices used in close proximity to the ear (frequency range of 300 MHz to 3 GHz)", February 2005

Methods Applied and Interpretation of Parameters:

- **NORM_{x,y,z}:** Assessed for E-field polarization $\vartheta = 0$ ($f \leq 900$ MHz in TEM-cell; $f > 1800$ MHz: R22 waveguide). NORM_{x,y,z} are only intermediate values, i.e., the uncertainties of NORM_{x,y,z} does not affect the E²-field uncertainty inside TSL (see below ConvF).
- **NORM(f)_{x,y,z} = NORM_{x,y,z} * frequency_response** (see Frequency Response Chart). This linearization is implemented in DASY4 software versions later than 4.2. The uncertainty of the frequency response is included in the stated uncertainty of ConvF.
- **DCP_{x,y,z}:** DCP are numerical linearization parameters assessed based on the data of power sweep with CW signal (no uncertainty required). DCP does not depend on frequency nor media.
- **PAR:** PAR is the Peak to Average Ratio that is not calibrated but determined based on the signal characteristics
- **A_{x,y,z}; B_{x,y,z}; C_{x,y,z}; D_{x,y,z}; VR_{x,y,z}:** A, B, C, D are numerical linearization parameters assessed based on the data of power sweep for specific modulation signal. The parameters do not depend on frequency nor media. VR is the maximum calibration range expressed in RMS voltage across the diode.
- **ConvF and Boundary Effect Parameters:** Assessed in flat phantom using E-field (or Temperature Transfer Standard for $f \leq 800$ MHz) and inside waveguide using analytical field distributions based on power measurements for $f > 800$ MHz. The same setups are used for assessment of the parameters applied for boundary compensation (alpha, depth) of which typical uncertainty values are given. These parameters are used in DASY4 software to improve probe accuracy close to the boundary. The sensitivity in TSL corresponds to NORM_{x,y,z} * ConvF whereby the uncertainty corresponds to that given for ConvF. A frequency dependent ConvF is used in DASY version 4.4 and higher which allows extending the validity from ± 50 MHz to ± 100 MHz.
- **Spherical isotropy (3D deviation from isotropy):** in a field of low gradients realized using a flat phantom exposed by a patch antenna.
- **Sensor Offset:** The sensor offset corresponds to the offset of virtual measurement center from the probe tip (on probe axis). No tolerance required.
- **Connector Angle:** The angle is assessed using the information gained by determining the NORM_x (no uncertainty required).

ES3DV3 – SN:3052

September 24, 2014

Probe ES3DV3

SN:3052

Manufactured:	September 30, 2003
Repaired:	September 18, 2014
Calibrated:	September 24, 2014

Calibrated for DASY/EASY Systems
(Note: non-compatible with DASY2 system!)

ES3DV3- SN:3052

September 24, 2014

DASY/EASY - Parameters of Probe: ES3DV3 - SN:3052

Basic Calibration Parameters

	Sensor X	Sensor Y	Sensor Z	Unc (k=2)
Norm ($\mu\text{V}/(\text{V}/\text{m})^2$) ^A	1.13	0.42	1.10	± 10.1 %
DCP (mV) ^B	104.3	98.3	102.9	

Modulation Calibration Parameters

UID	Communication System Name		A dB	B dB√ μV	C	D dB	VR mV	Unc ^E (k=2)
0	CW	X	0.0	0.0	1.0	0.00	199.5	±3.5 %
		Y	0.0	0.0	1.0		180.7	
		Z	0.0	0.0	1.0		199.0	
10011- CAB	UMTS-FDD (WCDMA)	X	3.36	67.7	18.9	2.91	136.2	±0.7 %
		Y	3.05	64.3	16.5		144.5	
		Z	3.24	66.7	18.2		136.3	
10012- CAA	IEEE 802.11b WiFi 2.4 GHz (DSSS, 1 Mbps)	X	2.93	69.1	19.0	1.87	138.2	±0.7 %
		Y	2.41	64.0	15.8		143.3	
		Z	2.90	68.5	18.4		137.9	
10013- CAA	IEEE 802.11g WiFi 2.4 GHz (DSSS-OFDM, 6 Mbps)	X	11.13	70.8	23.4	9.46	135.8	±3.3 %
		Y	10.99	69.1	21.9		143.7	
		Z	11.06	70.4	23.1		135.3	
10021- DAB	GSM-FDD (TDMA, GMSK)	X	10.62	86.4	23.2	9.39	144.0	±1.9 %
		Y	2.75	68.5	16.2		87.9	
		Z	17.37	95.8	26.8		144.4	
10023- DAB	GPRS-FDD (TDMA, GMSK, TN 0)	X	15.14	93.2	25.8	9.57	145.2	±2.2 %
		Y	2.61	67.2	15.9		82.8	
		Z	19.74	98.0	27.4		130.3	
10024- DAB	GPRS-FDD (TDMA, GMSK, TN 0-1)	X	32.39	99.8	25.1	6.56	128.1	±1.4 %
		Y	4.81	76.8	17.9		126.8	
		Z	34.20	99.8	25.0		141.2	
10025- DAB	EDGE-FDD (TDMA, 8PSK, TN 0)	X	13.71	99.1	38.4	12.62	139.8	±3.0 %
		Y	4.87	67.9	23.1		59.1	
		Z	13.94	99.6	38.7		126.3	
10026- DAB	EDGE-FDD (TDMA, 8PSK, TN 0-1)	X	11.01	90.1	31.4	9.55	126.7	±2.5 %
		Y	5.75	74.5	24.4		124.5	
		Z	12.89	93.9	33.0		139.8	
10027- DAB	GPRS-FDD (TDMA, GMSK, TN 0-1-2)	X	32.71	94.5	21.4	4.80	144.2	±1.4 %
		Y	2.79	69.7	13.7		132.6	
		Z	50.44	99.9	22.9		130.7	
10028- DAB	GPRS-FDD (TDMA, GMSK, TN 0-1-2-3)	X	47.66	99.5	22.1	3.55	126.6	±2.2 %
		Y	24.59	92.3	19.6		146.3	
		Z	55.77	99.6	21.9		143.7	
10029- DAB	EDGE-FDD (TDMA, 8PSK, TN 0-1-2)	X	16.20	99.3	33.6	7.78	147.3	±3.3 %
		Y	5.14	72.9	22.5		132.6	
		Z	10.86	89.3	29.7		137.0	

Certificate No: ES3-3052_Sep14

Page 4 of 17

ES3DV3– SN:3052

September 24, 2014

10048-CAA	DECT (TDD, TDMA/FDM, GFSK, Full Slot, 24)	X	7.45	83.0	25.7	13.80	90.0	±1.9 %
		Y	2.39	62.3	15.5		32.0	
		Z	7.27	82.6	25.8		84.7	
10049-CAA	DECT (TDD, TDMA/FDM, GFSK, Double Slot, 12)	X	13.92	91.7	26.1	10.79	148.8	±1.7 %
		Y	3.21	69.9	17.8		65.7	
		Z	14.37	92.6	26.6		138.7	
10058-DAB	EDGE-FDD (TDMA, 8PSK, TN 0-1-2-3)	X	7.02	80.2	25.3	6.52	128.8	±2.2 %
		Y	5.09	73.7	22.3		141.9	
		Z	14.75	96.3	31.4		144.1	
10098-CAB	UMTS-FDD (HSUPA, Subtest 2)	X	4.49	66.4	18.4	3.98	127.8	±0.9 %
		Y	4.51	65.2	17.4		150.0	
		Z	4.62	66.8	18.7		140.4	
10100-CAB	LTE-FDD (SC-FDMA, 100% RB, 20 MHz, QPSK)	X	6.34	67.3	19.6	5.67	134.3	±1.4 %
		Y	6.31	66.1	18.5		134.8	
		Z	6.54	68.0	20.0		148.0	
10102-CAB	LTE-FDD (SC-FDMA, 100% RB, 20 MHz, 64-QAM)	X	7.72	67.9	20.3	6.60	147.1	±1.9 %
		Y	7.76	66.9	19.3		148.6	
		Z	7.62	67.5	20.1		134.4	
10101-CAB	LTE-FDD (SC-FDMA, 100% RB, 20 MHz, 16-QAM)	X	7.72	67.9	20.3	6.42	147.1	±12.2 %
		Y	7.76	66.9	19.3		148.6	
		Z	7.62	67.5	20.1		134.4	
10110-CAB	LTE-FDD (SC-FDMA, 100% RB, 5 MHz, QPSK)	X	5.87	66.2	19.2	5.75	129.6	±1.4 %
		Y	5.91	65.3	18.3		130.0	
		Z	6.06	67.0	19.7		141.4	
10154-CAB	LTE-FDD (SC-FDMA, 50% RB, 10 MHz, QPSK)	X	5.87	66.2	19.2	5.75	129.6	±12.2 %
		Y	5.91	65.3	18.3		130.0	
		Z	6.06	67.0	19.7		141.4	
10112-CAB	LTE-FDD (SC-FDMA, 100% RB, 10 MHz, 64-QAM)	X	7.44	67.6	20.2	6.59	142.4	±1.9 %
		Y	7.48	66.6	19.2		144.0	
		Z	7.35	67.3	20.0		130.5	
10109-CAB	LTE-FDD (SC-FDMA, 100% RB, 10 MHz, 16-QAM)	X	7.44	67.6	20.2	6.43	142.4	±12.2 %
		Y	7.48	66.6	19.2		144.0	
		Z	7.35	67.3	20.0		130.5	
10150-CAB	LTE-FDD (SC-FDMA, 50% RB, 20 MHz, 64-QAM)	X	7.44	67.6	20.2	6.60	142.4	±12.2 %
		Y	7.48	66.6	19.2		144.0	
		Z	7.35	67.3	20.0		130.5	
10149-CAB	LTE-FDD (SC-FDMA, 50% RB, 20 MHz, 16-QAM)	X	7.44	67.6	20.2	6.42	142.4	±12.2 %
		Y	7.48	66.6	19.2		144.0	
		Z	7.35	67.3	20.0		130.5	
10117-CAA	IEEE 802.11n (HT Mixed, 13.5 Mbps, BPSK)	X	10.44	69.6	21.7	8.07	149.5	±2.7 %
		Y	10.10	67.7	20.2		124.9	
		Z	10.31	69.2	21.5		136.0	
10140-CAB	LTE-FDD (SC-FDMA, 100% RB, 15 MHz, 16-QAM)	X	7.66	68.0	20.2	6.49	147.5	±1.7 %
		Y	7.46	66.2	18.9		124.4	
		Z	7.58	67.6	20.1		134.6	

ES3DV3- SN:3052

September 24, 2014

10141-CAB	LTE-FDD (SC-FDMA, 100% RB, 15 MHz, 64-QAM)	X	7.66	68.0	20.2	6.53	147.5	±12.2 %
		Y	7.46	66.2	18.9		124.4	
		Z	7.58	67.6	20.1		134.6	
10146-CAB	LTE-FDD (SC-FDMA, 100% RB, 1.4 MHz, 16-QAM)	X	6.36	66.9	19.8	6.41	127.6	±1.4 %
		Y	6.30	65.7	18.7		128.9	
		Z	6.55	67.6	20.2		139.3	
10147-CAB	LTE-FDD (SC-FDMA, 100% RB, 1.4 MHz, 64-QAM)	X	6.63	67.1	20.0	6.72	127.1	±1.7 %
		Y	6.58	65.9	19.0		128.3	
		Z	6.83	67.8	20.5		139.2	
10157-CAB	LTE-FDD (SC-FDMA, 50% RB, 5 MHz, 16-QAM)	X	6.62	66.8	19.8	6.49	130.4	±1.7 %
		Y	6.65	65.8	18.9		133.0	
		Z	6.83	67.5	20.2		142.9	
10158-CAB	LTE-FDD (SC-FDMA, 50% RB, 10 MHz, 64-QAM)	X	7.15	67.3	20.0	6.62	137.7	±1.9 %
		Y	7.22	66.4	19.2		140.7	
		Z	7.05	66.9	19.9		125.4	
10111-CAB	LTE-FDD (SC-FDMA, 100% RB, 5 MHz, 16-QAM)	X	7.15	67.3	20.0	6.44	137.7	±12.2 %
		Y	7.22	66.4	19.2		140.7	
		Z	7.05	66.9	19.9		125.4	
10113-CAB	LTE-FDD (SC-FDMA, 100% RB, 5 MHz, 64-QAM)	X	7.15	67.3	20.0	6.62	137.7	±12.2 %
		Y	7.22	66.4	19.2		140.7	
		Z	7.05	66.9	19.9		125.4	
10155-CAB	LTE-FDD (SC-FDMA, 50% RB, 10 MHz, 16-QAM)	X	7.15	67.3	20.0	6.43	137.7	±12.2 %
		Y	7.22	66.4	19.2		140.7	
		Z	7.05	66.9	19.9		125.4	
10161-CAB	LTE-FDD (SC-FDMA, 50% RB, 15 MHz, 16-QAM)	X	7.15	67.3	20.0	6.43	137.7	±12.2 %
		Y	7.22	66.4	19.2		140.7	
		Z	7.05	66.9	19.9		125.4	
10162-CAB	LTE-FDD (SC-FDMA, 50% RB, 15 MHz, 64-QAM)	X	7.15	67.3	20.0	6.58	137.7	±12.2 %
		Y	7.22	66.4	19.2		140.7	
		Z	7.05	66.9	19.9		125.4	
10159-CAB	LTE-FDD (SC-FDMA, 50% RB, 5 MHz, 64-QAM)	X	6.78	67.1	20.0	6.56	132.1	±1.9 %
		Y	6.79	66.1	19.0		135.6	
		Z	6.97	67.8	20.4		144.2	
10173-CAB	LTE-TDD (SC-FDMA, 1 RB, 20 MHz, 16-QAM)	X	8.21	77.1	27.3	9.48	128.8	±2.7 %
		Y	6.63	70.6	23.3		143.3	
		Z	9.09	80.2	29.0		142.6	
10226-CAA	LTE-TDD (SC-FDMA, 1 RB, 1.4 MHz, 16-QAM)	X	8.21	77.1	27.3	9.49	128.8	±12.2 %
		Y	6.63	70.6	23.3		143.3	
		Z	9.09	80.2	29.0		142.6	
10235-CAB	LTE-TDD (SC-FDMA, 1 RB, 10 MHz, 16-QAM)	X	8.21	77.1	27.3	9.48	128.8	±12.2 %
		Y	6.63	70.6	23.3		143.3	
		Z	9.09	80.2	29.0		142.6	
10229-CAB	LTE-TDD (SC-FDMA, 1 RB, 3 MHz, 16-QAM)	X	8.21	77.1	27.3	9.48	128.8	±12.2 %
		Y	6.63	70.6	23.3		143.3	
		Z	9.09	80.2	29.0		142.6	

ES3DV3– SN:3052

September 24, 2014

10232-CAB	LTE-TDD (SC-FDMA, 1 RB, 5 MHz, 16-QAM)	X	8.21	77.1	27.3	9.48	128.8	±12.2 %
		Y	6.63	70.6	23.3		143.3	
		Z	9.09	80.2	29.0		142.6	
10238-CAB	LTE-TDD (SC-FDMA, 1 RB, 15 MHz, 16-QAM)	X	8.21	77.1	27.3	9.48	128.8	±12.2 %
		Y	6.63	70.6	23.3		143.3	
		Z	9.09	80.2	29.0		142.6	
10179-CAB	LTE-FDD (SC-FDMA, 1 RB, 10 MHz, 64-QAM)	X	5.61	67.5	20.4	6.50	131.2	±1.9 %
		Y	5.52	66.6	19.5		149.2	
		Z	5.78	68.2	20.8		142.1	
10170-CAB	LTE-FDD (SC-FDMA, 1 RB, 20 MHz, 16-QAM)	X	5.61	67.5	20.4	6.52	131.2	±12.2 %
		Y	5.52	66.6	19.5		149.2	
		Z	5.78	68.2	20.8		142.1	
10176-CAB	LTE-FDD (SC-FDMA, 1 RB, 10 MHz, 16-QAM)	X	5.61	67.5	20.4	6.52	131.2	±12.2 %
		Y	5.52	66.6	19.5		149.2	
		Z	5.78	68.2	20.8		142.1	
10188-CAB	LTE-FDD (SC-FDMA, 1 RB, 1.4 MHz, 16-QAM)	X	5.61	67.5	20.4	6.52	131.2	±12.2 %
		Y	5.52	66.6	19.5		149.2	
		Z	5.78	68.2	20.8		142.1	
10180-CAB	LTE-FDD (SC-FDMA, 1 RB, 5 MHz, 64-QAM)	X	5.61	67.5	20.4	6.50	131.2	±12.2 %
		Y	5.52	66.6	19.5		149.2	
		Z	5.78	68.2	20.8		142.1	
10178-CAB	LTE-FDD (SC-FDMA, 1 RB, 5 MHz, 16-QAM)	X	5.61	67.5	20.4	6.52	131.2	±12.2 %
		Y	5.52	66.6	19.5		149.2	
		Z	5.78	68.2	20.8		142.1	
10182-CAB	LTE-FDD (SC-FDMA, 1 RB, 15 MHz, 16-QAM)	X	5.61	67.5	20.4	6.52	131.2	±12.2 %
		Y	5.52	66.6	19.5		149.2	
		Z	5.78	68.2	20.8		142.1	
10185-CAB	LTE-FDD (SC-FDMA, 1 RB, 3 MHz, 16-QAM)	X	5.61	67.5	20.4	6.51	131.2	±12.2 %
		Y	5.52	66.6	19.5		149.2	
		Z	5.78	68.2	20.8		142.1	
10187-CAB	LTE-FDD (SC-FDMA, 1 RB, 1.4 MHz, QPSK)	X	4.91	66.6	19.6	5.73	132.5	±1.7 %
		Y	4.82	65.4	18.6		149.1	
		Z	5.03	67.1	19.9		144.0	
10166-CAB	LTE-FDD (SC-FDMA, 50% RB, 1.4 MHz, QPSK)	X	4.91	66.6	19.6	5.46	132.5	±12.2 %
		Y	4.82	65.4	18.6		149.1	
		Z	5.03	67.1	19.9		144.0	
10181-CAB	LTE-FDD (SC-FDMA, 1 RB, 15 MHz, QPSK)	X	4.91	66.6	19.6	5.72	132.5	±12.2 %
		Y	4.82	65.4	18.6		149.1	
		Z	5.03	67.1	19.9		144.0	
10169-CAB	LTE-FDD (SC-FDMA, 1 RB, 20 MHz, QPSK)	X	4.91	66.6	19.6	5.73	132.5	±12.2 %
		Y	4.82	65.4	18.6		149.1	
		Z	5.03	67.1	19.9		144.0	
10175-CAB	LTE-FDD (SC-FDMA, 1 RB, 10 MHz, QPSK)	X	4.91	66.6	19.6	5.72	132.5	±12.2 %
		Y	4.82	65.4	18.6		149.1	
		Z	5.03	67.1	19.9		144.0	

ES3DV3– SN:3052

September 24, 2014

10177-CAD	LTE-FDD (SC-FDMA, 1 RB, 5 MHz, QPSK)	X	4.91	66.6	19.6	5.73	132.5	±12.2 %
		Y	4.82	65.4	18.6		149.1	
		Z	5.03	67.1	19.9		144.0	
10184-CAB	LTE-FDD (SC-FDMA, 1 RB, 3 MHz, QPSK)	X	4.91	66.6	19.6	5.73	132.5	±12.2 %
		Y	4.82	65.4	18.6		149.1	
		Z	5.03	67.1	19.9		144.0	
10196-CAA	IEEE 802.11n (HT Mixed, 6.5 Mbps, BPSK)	X	9.98	69.0	21.5	8.10	140.6	±2.7 %
		Y	10.10	68.2	20.6		140.7	
		Z	9.90	68.8	21.4		129.4	
10225-CAB	UMTS-FDD (HSPA+)	X	6.99	67.1	19.5	5.97	143.6	±1.4 %
		Y	7.11	66.4	18.8		149.0	
		Z	6.91	66.8	19.3		133.0	
10228-CAA	LTE-TDD (SC-FDMA, 1 RB, 1.4 MHz, QPSK)	X	8.00	76.7	27.1	9.22	132.0	±2.7 %
		Y	6.43	70.1	23.1		147.2	
		Z	8.85	79.7	28.7		146.7	
10237-CAB	LTE-TDD (SC-FDMA, 1 RB, 10 MHz, QPSK)	X	8.00	76.7	27.1	9.21	132.0	±12.2 %
		Y	6.43	70.1	23.1		147.2	
		Z	8.85	79.7	28.7		146.7	
10172-CAB	LTE-TDD (SC-FDMA, 1 RB, 20 MHz, QPSK)	X	8.00	76.7	27.1	9.21	132.0	±12.2 %
		Y	6.43	70.1	23.1		147.2	
		Z	8.85	79.7	28.7		146.7	
10231-CAB	LTE-TDD (SC-FDMA, 1 RB, 3 MHz, QPSK)	X	8.00	76.7	27.1	9.19	132.0	±12.2 %
		Y	6.43	70.1	23.1		147.2	
		Z	8.85	79.7	28.7		146.7	
10234-CAB	LTE-TDD (SC-FDMA, 1 RB, 5 MHz, QPSK)	X	8.00	76.7	27.1	9.21	132.0	±12.2 %
		Y	6.43	70.1	23.1		147.2	
		Z	8.85	79.7	28.7		146.7	
10240-CAB	LTE-TDD (SC-FDMA, 1 RB, 15 MHz, QPSK)	X	8.00	76.7	27.1	9.21	132.0	±12.2 %
		Y	6.43	70.1	23.1		147.2	
		Z	8.85	79.7	28.7		146.7	
10246-CAB	LTE-TDD (SC-FDMA, 50% RB, 3 MHz, QPSK)	X	8.24	73.2	25.3	9.30	124.9	±3.8 %
		Y	7.22	68.4	22.2		139.6	
		Z	8.98	75.8	26.8		140.1	
10249-CAB	LTE-TDD (SC-FDMA, 50% RB, 5 MHz, QPSK)	X	8.24	73.2	25.3	9.29	124.9	±12.2 %
		Y	7.22	68.4	22.2		139.6	
		Z	8.98	75.8	26.8		140.1	
10258-CAA	LTE-TDD (SC-FDMA, 100% RB, 1.4 MHz, QPSK)	X	8.24	73.2	25.3	9.34	124.9	±12.2 %
		Y	7.22	68.4	22.2		139.6	
		Z	8.98	75.8	26.8		140.1	
10256-CAA	LTE-TDD (SC-FDMA, 100% RB, 1.4 MHz, 16-QAM)	X	9.05	73.9	26.0	9.96	128.6	±3.8 %
		Y	8.03	69.3	22.9		146.6	
		Z	9.83	76.5	27.6		144.6	
10247-CAB	LTE-TDD (SC-FDMA, 50% RB, 5 MHz, 16-QAM)	X	9.05	73.9	26.0	9.91	128.6	±12.2 %
		Y	8.03	69.3	22.9		146.6	
		Z	9.83	76.5	27.6		144.6	

ES3DV3- SN:3052

September 24, 2014

10244-CAB	LTE-TDD (SC-FDMA, 50% RB, 3 MHz, 16-QAM)	X	9.05	73.9	26.0	10.06	128.6	±12.2 %
		Y	8.03	69.3	22.9		146.6	
		Z	9.83	76.5	27.6		144.6	
10262-CAB	LTE-TDD (SC-FDMA, 100% RB, 5 MHz, 16-QAM)	X	10.05	74.8	26.4	9.83	145.4	±3.3 %
		Y	8.44	68.3	22.1		138.9	
		Z	9.81	74.1	26.1		133.2	
10250-CAB	LTE-TDD (SC-FDMA, 50% RB, 10 MHz, 16-QAM)	X	10.05	74.8	26.4	9.81	145.4	±12.2 %
		Y	8.44	68.3	22.1		138.9	
		Z	9.81	74.1	26.1		133.2	
10259-CAB	LTE-TDD (SC-FDMA, 100% RB, 3 MHz, 16-QAM)	X	10.05	74.8	26.4	9.98	145.4	±12.2 %
		Y	8.44	68.3	22.1		138.9	
		Z	9.81	74.1	26.1		133.2	
10264-CAB	LTE-TDD (SC-FDMA, 100% RB, 5 MHz, QPSK)	X	9.03	74.4	25.8	9.23	135.1	±3.3 %
		Y	7.47	67.7	21.5		132.4	
		Z	8.83	73.7	25.5		124.7	
10252-CAB	LTE-TDD (SC-FDMA, 50% RB, 10 MHz, QPSK)	X	9.03	74.4	25.8	9.24	135.1	±12.2 %
		Y	7.47	67.7	21.5		132.4	
		Z	8.83	73.7	25.5		124.7	
10261-CAB	LTE-TDD (SC-FDMA, 100% RB, 3 MHz, QPSK)	X	9.03	74.4	25.8	9.24	135.1	±12.2 %
		Y	7.47	67.7	21.5		132.4	
		Z	8.83	73.7	25.5		124.7	
10265-CAB	LTE-TDD (SC-FDMA, 100% RB, 10 MHz, 16-QAM)	X	9.82	72.7	25.2	9.92	127.0	±3.8 %
		Y	8.92	68.6	22.3		145.9	
		Z	10.52	74.9	26.6		142.0	
10152-CAB	LTE-TDD (SC-FDMA, 50% RB, 20 MHz, 16-QAM)	X	9.82	72.7	25.2	9.92	127.0	±12.2 %
		Y	8.92	68.6	22.3		145.9	
		Z	10.52	74.9	26.6		142.0	
10267-CAB	LTE-TDD (SC-FDMA, 100% RB, 10 MHz, QPSK)	X	9.90	75.7	26.4	9.30	144.2	±3.5 %
		Y	7.92	68.2	21.7		136.6	
		Z	9.53	74.6	25.9		131.7	
10151-CAB	LTE-TDD (SC-FDMA, 50% RB, 20 MHz, QPSK)	X	9.90	75.7	26.4	9.28	144.2	±12.2 %
		Y	7.92	68.2	21.7		136.6	
		Z	9.53	74.6	25.9		131.7	
10297-AAA	LTE-FDD (SC-FDMA, 50% RB, 20 MHz, QPSK)	X	6.25	67.0	19.6	5.81	133.5	±1.4 %
		Y	6.26	65.9	18.6		134.7	
		Z	6.44	67.6	19.9		147.8	
10299-AAA	LTE-FDD (SC-FDMA, 50% RB, 3 MHz, 16-QAM)	X	6.52	67.2	19.9	6.39	130.9	±1.7 %
		Y	6.48	66.0	18.9		130.5	
		Z	6.68	67.7	20.2		144.1	
10300-AAA	LTE-FDD (SC-FDMA, 50% RB, 3 MHz, 64-QAM)	X	6.71	67.2	20.0	6.60	131.2	±1.7 %
		Y	6.66	66.0	19.0		129.6	
		Z	6.89	67.9	20.4		143.8	
10415-AAA	IEEE 802.11b WiFi 2.4 GHz (DSSS, 1 Mbps, 99pc duty cycle)	X	2.67	68.6	18.7	1.54	145.7	±0.5 %
		Y	2.30	64.3	16.0		141.9	
		Z	2.54	67.4	18.1		135.2	

ES3DV3– SN:3052

September 24, 2014

10416-AAA	IEEE 802.11g WiFi 2.4 GHz (ERP-OFDM, 6 Mbps, 99pc duty cycle)	X	10.13	69.3	21.7	8.23	143.5	±2.7 %
		Y	10.20	68.2	20.7		142.2	
		Z	10.02	68.9	21.5		131.6	
10418-AAA	IEEE 802.11g WiFi 2.4 GHz (DSSS-OFDM, 6 Mbps, 99pc duty cycle, Long preamble)	X	10.01	69.2	21.6	8.14	142.9	±2.5 %
		Y	10.10	68.3	20.7		142.3	
		Z	9.92	69.0	21.6		132.0	
10419-AAA	IEEE 802.11g WiFi 2.4 GHz (DSSS-OFDM, 6 Mbps, 99pc duty cycle, Short preamble)	X	10.08	69.2	21.7	8.19	144.0	±2.7 %
		Y	10.19	68.3	20.8		143.7	
		Z	10.00	69.0	21.6		132.9	

The reported uncertainty of measurement is stated as the standard uncertainty of measurement multiplied by the coverage factor $k=2$, which for a normal distribution corresponds to a coverage probability of approximately 95%.

^A The uncertainties of NormX,Y,Z do not affect the E^2 -field uncertainty inside TSL (see Pages 11 and 12).

^B Numerical linearization parameter: uncertainty not required.

^E Uncertainty is determined using the max. deviation from linear response applying rectangular distribution and is expressed for the square of the field value.

ES3DV3- SN:3052

September 24, 2014

DASY/EASY - Parameters of Probe: ES3DV3 - SN:3052

Calibration Parameter Determined in Head Tissue Simulating Media

f (MHz) ^C	Relative Permittivity ^F	Conductivity (S/m) ^F	ConvF X	ConvF Y	ConvF Z	Alpha ^G	Depth ^G (mm)	Unct. (k=2)
750	41.9	0.89	6.73	6.73	6.73	0.80	1.13	± 12.0 %
835	41.5	0.90	6.50	6.50	6.50	0.52	1.40	± 12.0 %
900	41.5	0.97	6.40	6.40	6.40	0.77	1.16	± 12.0 %
1750	40.1	1.37	5.28	5.28	5.28	0.41	1.60	± 12.0 %
1900	40.0	1.40	5.12	5.12	5.12	0.43	1.62	± 12.0 %
2000	40.0	1.40	5.10	5.10	5.10	0.41	1.60	± 12.0 %
2450	39.2	1.80	4.52	4.52	4.52	0.71	1.28	± 12.0 %
2600	39.0	1.96	4.37	4.37	4.37	0.80	1.21	± 12.0 %

^C Frequency validity above 300 MHz of ± 100 MHz only applies for DASY v4.4 and higher (see Page 2), else it is restricted to ± 50 MHz. The uncertainty is the RSS of the ConvF uncertainty at calibration frequency and the uncertainty for the indicated frequency band. Frequency validity below 300 MHz is ± 10, 25, 40, 50 and 70 MHz for ConvF assessments at 30, 64, 128, 150 and 220 MHz respectively. Above 5 GHz frequency validity can be extended to ± 110 MHz.

^F At frequencies below 3 GHz, the validity of tissue parameters (ϵ and σ) can be relaxed to ± 10% if liquid compensation formula is applied to measured SAR values. At frequencies above 3 GHz, the validity of tissue parameters (ϵ and σ) is restricted to ± 5%. The uncertainty is the RSS of the ConvF uncertainty for indicated target tissue parameters.

^G Alpha/Depth are determined during calibration. SPEAG warrants that the remaining deviation due to the boundary effect after compensation is always less than ± 1% for frequencies below 3 GHz and below ± 2% for frequencies between 3-6 GHz at any distance larger than half the probe tip diameter from the boundary.

ES3DV3– SN:3052

September 24, 2014

DASY/EASY - Parameters of Probe: ES3DV3 - SN:3052

Calibration Parameter Determined in Body Tissue Simulating Media

f (MHz) ^C	Relative Permittivity ^F	Conductivity (S/m) ^F	ConvF X	ConvF Y	ConvF Z	Alpha ^G	Depth ^C (mm)	Unct. (k=2)
750	55.5	0.96	6.34	6.34	6.34	0.80	1.14	± 12.0 %
835	55.2	0.97	6.26	6.26	6.26	0.75	1.18	± 12.0 %
900	55.0	1.05	6.14	6.14	6.14	0.44	1.56	± 12.0 %
1750	53.4	1.49	4.94	4.94	4.94	0.46	1.68	± 12.0 %
1900	53.3	1.52	4.71	4.71	4.71	0.45	1.73	± 12.0 %
2000	53.3	1.52	4.75	4.75	4.75	0.55	1.56	± 12.0 %
2450	52.7	1.95	4.30	4.30	4.30	0.74	1.10	± 12.0 %
2600	52.5	2.16	4.16	4.16	4.16	0.80	1.01	± 12.0 %

^C Frequency validity above 300 MHz of ± 100 MHz only applies for DASY v4.4 and higher (see Page 2), else it is restricted to ± 50 MHz. The uncertainty is the RSS of the ConvF uncertainty at calibration frequency and the uncertainty for the indicated frequency band. Frequency validity below 300 MHz is ± 10, 25, 40, 50 and 70 MHz for ConvF assessments at 30, 64, 128, 150 and 220 MHz respectively. Above 5 GHz frequency validity can be extended to ± 110 MHz.

^F At frequencies below 3 GHz, the validity of tissue parameters (ϵ and σ) can be relaxed to ± 10% if liquid compensation formula is applied to measured SAR values. At frequencies above 3 GHz, the validity of tissue parameters (ϵ and σ) is restricted to ± 5%. The uncertainty is the RSS of the ConvF uncertainty for indicated target tissue parameters.

^G Alpha/Depth are determined during calibration. SPEAG warrants that the remaining deviation due to the boundary effect after compensation is always less than ± 1% for frequencies below 3 GHz and below ± 2% for frequencies between 3-6 GHz at any distance larger than half the probe tip diameter from the boundary.

ES3DV3– SN:3052

September 24, 2014

Frequency Response of E-Field (TEM-Cell:ifi110 EXX, Waveguide: R22)

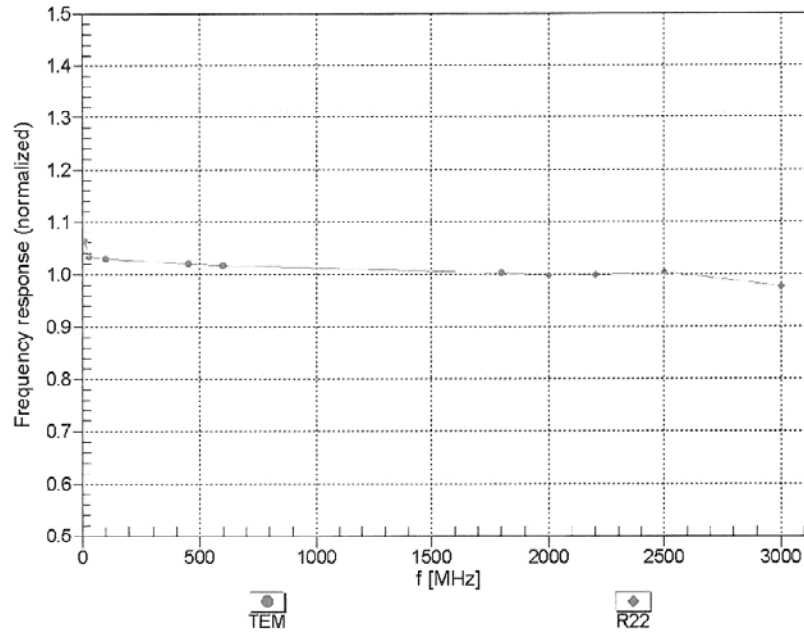

Uncertainty of Frequency Response of E-field: $\pm 6.3\%$ ($k=2$)

ES3DV3- SN:3052

September 24, 2014

Receiving Pattern (ϕ), $\theta = 0^\circ$

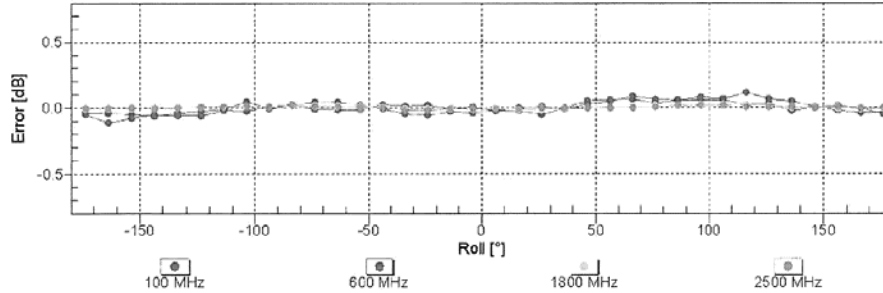
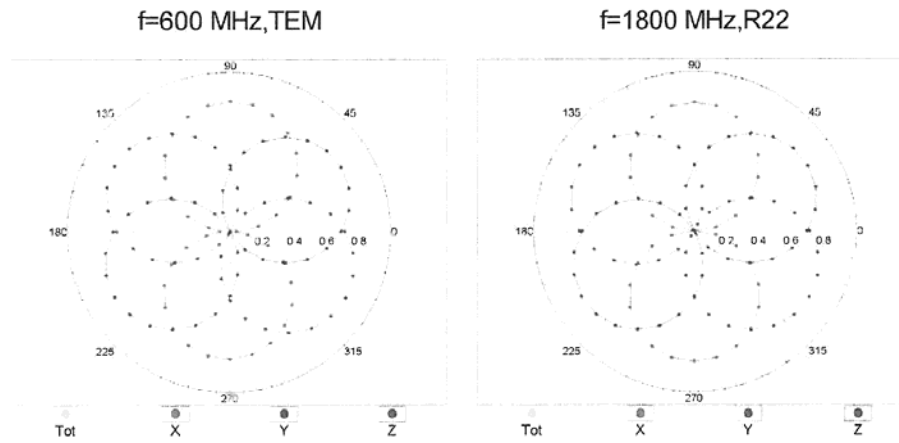

Uncertainty of Axial Isotropy Assessment: $\pm 0.5\%$ (k=2)

ES3DV3- SN:3052

September 24, 2014

Dynamic Range $f(\text{SAR}_{\text{head}})$ (TEM cell , $f_{\text{eval}} = 1900 \text{ MHz}$)

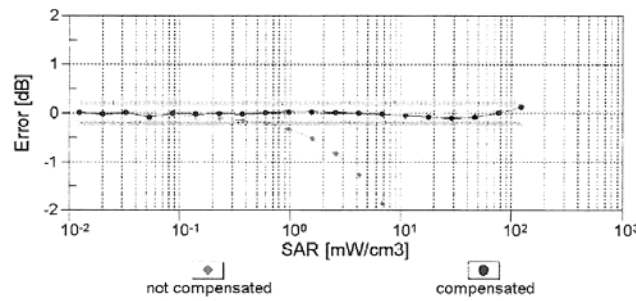
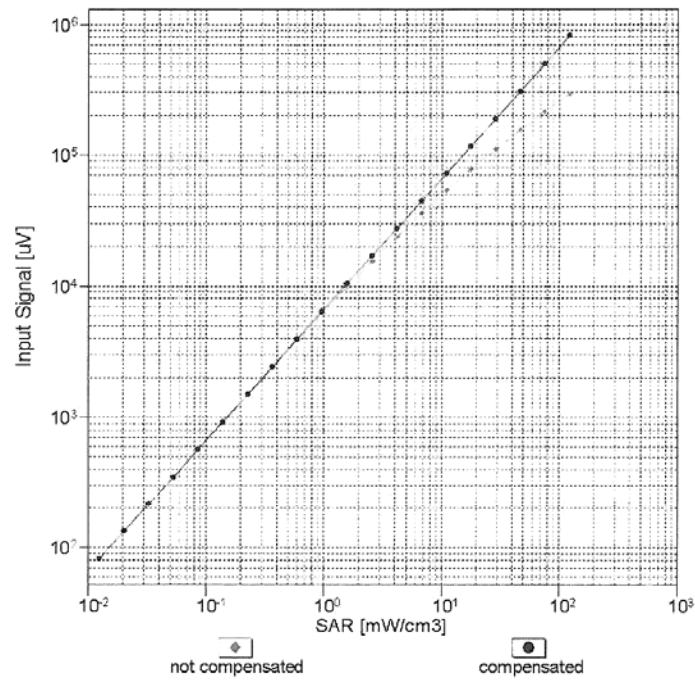

Uncertainty of Linearity Assessment: $\pm 0.6\%$ ($k=2$)

ES3DV3- SN:3052

September 24, 2014

Conversion Factor Assessment

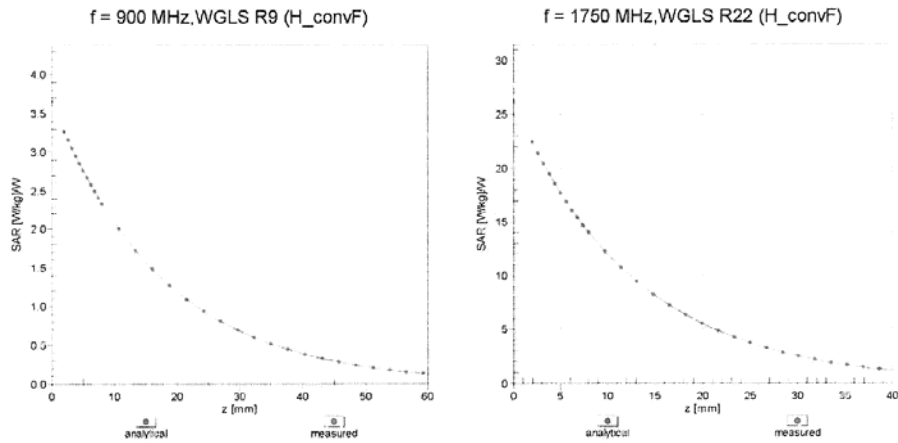

Deviation from Isotropy in Liquid

Error (ϕ , θ), f = 900 MHz

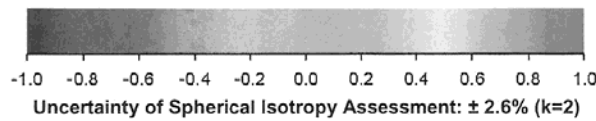
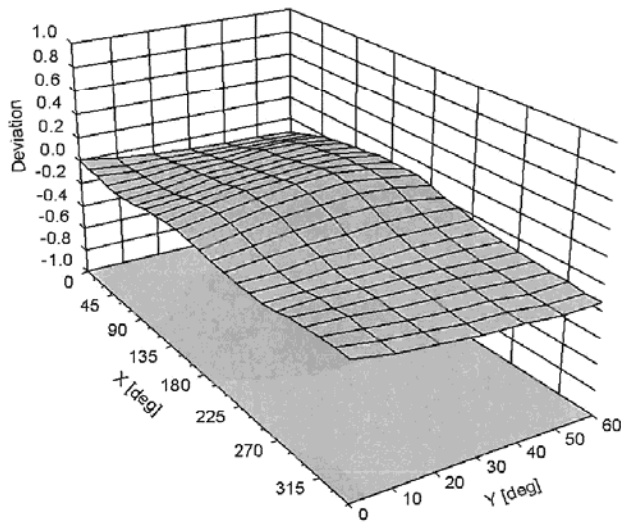

ES3DV3– SN:3052

September 24, 2014

DASY/EASY - Parameters of Probe: ES3DV3 - SN:3052

Other Probe Parameters

Sensor Arrangement	Triangular
Connector Angle (°)	-53.7
Mechanical Surface Detection Mode	enabled
Optical Surface Detection Mode	disabled
Probe Overall Length	337 mm
Probe Body Diameter	10 mm
Tip Length	10 mm
Tip Diameter	4 mm
Probe Tip to Sensor X Calibration Point	2 mm
Probe Tip to Sensor Y Calibration Point	2 mm
Probe Tip to Sensor Z Calibration Point	2 mm
Recommended Measurement Distance from Surface	2 mm

**Calibration Laboratory of
 Schmid & Partner
 Engineering AG**
 Zeughausstrasse 43, 8004 Zurich, Switzerland



S Schweizerischer Kalibrierdienst
C Service suisse d'étalonnage
S Servizio svizzero di taratura
S Swiss Calibration Service

Accredited by the Swiss Accreditation Service (SAS)
 The Swiss Accreditation Service is one of the signatories to the EA
 Multilateral Agreement for the recognition of calibration certificates

Accreditation No.: **SCS 108**

Client **AT4 Wireless**

Certificate No: **D900V2-1d007_Jul13**

CALIBRATION CERTIFICATE

Object **D900V2 - SN: 1d007**

Calibration procedure(s) **QA CAL-05.v9
 Calibration procedure for dipole validation kits above 700 MHz**



Calibration date: **July 19, 2013**

This calibration certificate documents the traceability to national standards, which realize the physical units of measurements (SI).
 The measurements and the uncertainties with confidence probability are given on the following pages and are part of the certificate.

All calibrations have been conducted in the closed laboratory facility: environment temperature (22 ± 3)°C and humidity < 70%.

Calibration Equipment used (M&TE critical for calibration)

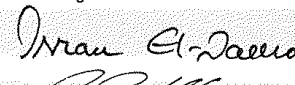
Primary Standards	ID #	Cal Date (Certificate No.)	Scheduled Calibration
Power meter EPM-442A	GB37480704	01-Nov-12 (No. 217-01640)	Oct-13
Power sensor HP 8481A	US37292783	01-Nov-12 (No. 217-01640)	Oct-13
Reference 20 dB Attenuator	SN: 5058 (20k)	04-Apr-13 (No. 217-01736)	Apr-14
Type-N mismatch combination	SN: 5047.3 / 06327	04-Apr-13 (No. 217-01739)	Apr-14
Reference Probe ES3DV3	SN: 3205	28-Dec-12 (No. ES3-3205_Dec12)	Dec-13
DAE4	SN: 601	25-Apr-13 (No. DAE4-601_Apr13)	Apr-14
Secondary Standards	ID #	Check Date (in house)	Scheduled Check
Power sensor HP 8481A	MY41092317	18-Oct-02 (in house check Oct-11)	In house check: Oct-13
RF generator R&S SMT-06	100005	04-Aug-99 (in house check Oct-11)	In house check: Oct-13
Network Analyzer HP 8753E	US37390585 S4206	18-Oct-01 (in house check Oct-12)	In house check: Oct-13

	Name	Function	Signature
Calibrated by:	Israe El-Naouq	Laboratory Technician	
Approved by:	Katja Pokovic	Technical Manager	

Issued: July 19, 2013

This calibration certificate shall not be reproduced except in full without written approval of the laboratory.

**Calibration Laboratory of
Schmid & Partner
Engineering AG**
Zeughausstrasse 43, 8004 Zurich, Switzerland



S Schweizerischer Kalibrierdienst
C Service suisse d'étalonnage
S Servizio svizzero di taratura
S Swiss Calibration Service

Accredited by the Swiss Accreditation Service (SAS)

The Swiss Accreditation Service is one of the signatories to the EA
Multilateral Agreement for the recognition of calibration certificates

Accreditation No.: **SCS 108**

Glossary:

TSL	tissue simulating liquid
ConvF	sensitivity in TSL / NORM x,y,z
N/A	not applicable or not measured

Calibration is Performed According to the Following Standards:

- IEEE Std 1528-2003, "IEEE Recommended Practice for Determining the Peak Spatial-Averaged Specific Absorption Rate (SAR) in the Human Head from Wireless Communications Devices: Measurement Techniques", December 2003
- IEC 62209-1, "Procedure to measure the Specific Absorption Rate (SAR) for hand-held devices used in close proximity to the ear (frequency range of 300 MHz to 3 GHz)", February 2005
- Federal Communications Commission Office of Engineering & Technology (FCC OET), "Evaluating Compliance with FCC Guidelines for Human Exposure to Radiofrequency Electromagnetic Fields; Additional Information for Evaluating Compliance of Mobile and Portable Devices with FCC Limits for Human Exposure to Radiofrequency Emissions", Supplement C (Edition 01-01) to Bulletin 65

Additional Documentation:

- DASY4/5 System Handbook

Methods Applied and Interpretation of Parameters:

- Measurement Conditions:* Further details are available from the Validation Report at the end of the certificate. All figures stated in the certificate are valid at the frequency indicated.
- Antenna Parameters with TSL:* The dipole is mounted with the spacer to position its feed point exactly below the center marking of the flat phantom section, with the arms oriented parallel to the body axis.
- Feed Point Impedance and Return Loss:* These parameters are measured with the dipole positioned under the liquid filled phantom. The impedance stated is transformed from the measurement at the SMA connector to the feed point. The Return Loss ensures low reflected power. No uncertainty required.
- Electrical Delay:* One-way delay between the SMA connector and the antenna feed point. No uncertainty required.
- SAR measured:* SAR measured at the stated antenna input power.
- SAR normalized:* SAR as measured, normalized to an input power of 1 W at the antenna connector.
- SAR for nominal TSL parameters:* The measured TSL parameters are used to calculate the nominal SAR result.

The reported uncertainty of measurement is stated as the standard uncertainty of measurement multiplied by the coverage factor $k=2$, which for a normal distribution corresponds to a coverage probability of approximately 95%.

Measurement Conditions

DASY system configuration, as far as not given on page 1.

DASY Version	DASY5	V52.8.7
Extrapolation	Advanced Extrapolation	
Phantom	Modular Flat Phantom	
Distance Dipole Center - TSL	15 mm	with Spacer
Zoom Scan Resolution	dx, dy, dz = 5 mm	
Frequency	900 MHz ± 1 MHz	

Head TSL parameters

The following parameters and calculations were applied.

	Temperature	Permittivity	Conductivity
Nominal Head TSL parameters	22.0 °C	41.5	0.97 mho/m
Measured Head TSL parameters	(22.0 ± 0.2) °C	41.6 ± 6 %	0.94 mho/m ± 6 %
Head TSL temperature change during test	< 0.5 °C	----	----

SAR result with Head TSL

SAR averaged over 1 cm ³ (1 g) of Head TSL	Condition	
SAR measured	250 mW input power	2.60 W/kg
SAR for nominal Head TSL parameters	normalized to 1W	10.7 W/kg ± 17.0 % (k=2)

SAR averaged over 10 cm ³ (10 g) of Head TSL	condition	
SAR measured	250 mW input power	1.68 W/kg
SAR for nominal Head TSL parameters	normalized to 1W	6.85 W/kg ± 16.5 % (k=2)

Body TSL parameters

The following parameters and calculations were applied.

	Temperature	Permittivity	Conductivity
Nominal Body TSL parameters	22.0 °C	55.0	1.05 mho/m
Measured Body TSL parameters	(22.0 ± 0.2) °C	54.8 ± 6 %	1.03 mho/m ± 6 %
Body TSL temperature change during test	< 0.5 °C	----	----

SAR result with Body TSL

SAR averaged over 1 cm ³ (1 g) of Body TSL	Condition	
SAR measured	250 mW input power	2.65 W/kg
SAR for nominal Body TSL parameters	normalized to 1W	10.7 W/kg ± 17.0 % (k=2)

SAR averaged over 10 cm ³ (10 g) of Body TSL	condition	
SAR measured	250 mW input power	1.72 W/kg
SAR for nominal Body TSL parameters	normalized to 1W	6.95 W/kg ± 16.5 % (k=2)

Appendix

Antenna Parameters with Head TSL

Impedance, transformed to feed point	50.7 Ω - 1.7 j Ω
Return Loss	- 34.9 dB

Antenna Parameters with Body TSL

Impedance, transformed to feed point	46.6 Ω - 3.5 j Ω
Return Loss	- 25.9 dB

General Antenna Parameters and Design

Electrical Delay (one direction)	1.410 ns
----------------------------------	----------

After long term use with 100W radiated power, only a slight warming of the dipole near the feedpoint can be measured.

The dipole is made of standard semirigid coaxial cable. The center conductor of the feeding line is directly connected to the second arm of the dipole. The antenna is therefore short-circuited for DC-signals. On some of the dipoles, small end caps are added to the dipole arms in order to improve matching when loaded according to the position as explained in the "Measurement Conditions" paragraph. The SAR data are not affected by this change. The overall dipole length is still according to the Standard.

No excessive force must be applied to the dipole arms, because they might bend or the soldered connections near the feedpoint may be damaged.

Additional EUT Data

Manufactured by	SPEAG
Manufactured on	February 13, 2004

DASY5 Validation Report for Head TSL

Date: 19.07.2013

Test Laboratory: SPEAG, Zurich, Switzerland

DUT: Dipole 900 MHz; Type: D900V2; Serial: D900V2 - SN: 1d007

Communication System: SDM - GVD; Frequency: 900 MHz

Communication System Frame Length in ms: 0

Medium parameters used: $f = 900$ MHz; $\sigma = 0.94$ S/m; $\epsilon_r = 41.6$; $\rho = 1000$ kg/m³

Phantom section: Flat Section

Measurement Standard: DASY5 (IEEE/IEC/ANSI C63.19-2007)

DASY52 Configuration:

- Probe: ES3DV3 - SN3205; ConvF(5.95, 5.95, 5.95); Calibrated: 28.12.2012;
- Sensor-Surface: 3mm (Mechanical Surface Detection)
- Electronics: DAE4 Sn601; Calibrated: 25.04.2013
- Phantom: Flat Phantom 4.9L; Type: QD000P49AA; Serial: 1001
- DASY52 52.8.7(1137); SEMCAD X 14.6.10(7164)

Dipole Calibration for Head Tissue/Pin=250 mW, d=15mm/Zoom Scan (7x7x7)/Cube 0:

Measurement grid: dx=5mm, dy=5mm, dz=5mm

Reference Value = 58.428 V/m; Power Drift = -0.00 dB

Peak SAR (extrapolated) = 3.92 W/kg

SAR(1 g) = 2.6 W/kg; SAR(10 g) = 1.68 W/kg

Maximum value of SAR (measured) = 3.05 W/kg

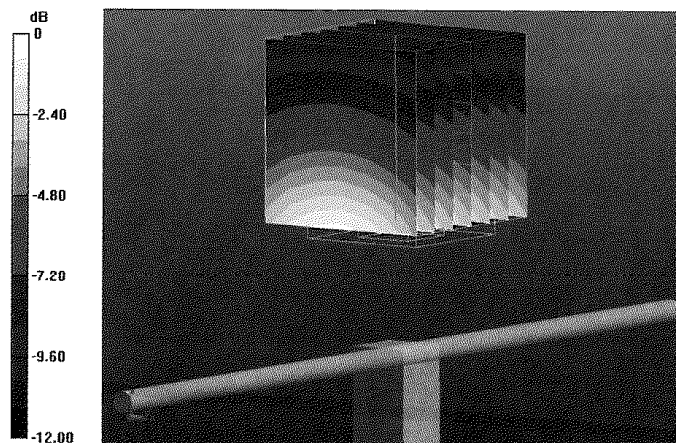

0 dB = 3.05 W/kg = 4.84 dBW/kg

Impedance Measurement Plot for Head TSL

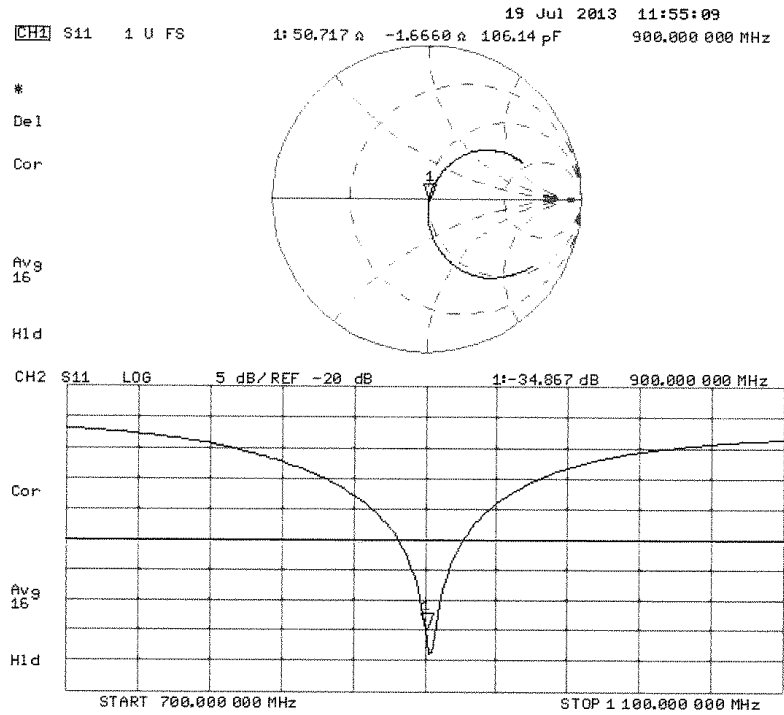

DASY5 Validation Report for Body TSL

Date: 19.07.2013

Test Laboratory: SPEAG, Zurich, Switzerland

DUT: Dipole 900 MHz; Type: D900V2; Serial: D900V2 - SN: 1d007

Communication System: UID 0 - CW; Frequency: 900 MHz

Medium parameters used: $f = 900$ MHz; $\sigma = 1.03$ S/m; $\epsilon_r = 54.8$; $\rho = 1000$ kg/m³

Phantom section: Flat Section

Measurement Standard: DASY5 (IEEE/IEC/ANSI C63.19-2007)

DASY52 Configuration:

- Probe: ES3DV3 - SN3205; ConvF(5.95, 5.95, 5.95); Calibrated: 28.12.2012;
- Sensor-Surface: 3mm (Mechanical Surface Detection)
- Electronics: DAE4 Sn601; Calibrated: 25.04.2013
- Phantom: Flat Phantom 4.9L; Type: QD000P49AA; Serial: 1001
- DASY52 52.8.7(1137); SEMCAD X 14.6.10(7164)

Dipole Calibration for Body Tissue/Pin=250 mW, d=15mm/Zoom Scan (7x7x7)/Cube 0:

Measurement grid: dx=5mm, dy=5mm, dz=5mm

Reference Value = 56.533 V/m; Power Drift = -0.00 dB

Peak SAR (extrapolated) = 3.90 W/kg

SAR(1 g) = 2.65 W/kg; SAR(10 g) = 1.72 W/kg

Maximum value of SAR (measured) = 3.09 W/kg

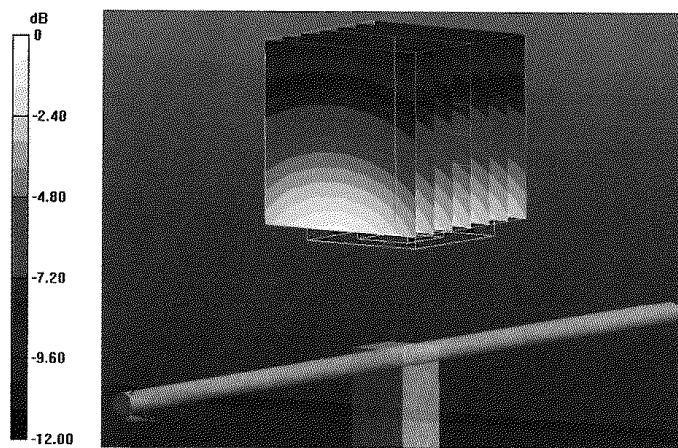

0 dB = 3.09 W/kg = 4.90 dBW/kg

Impedance Measurement Plot for Body TSL

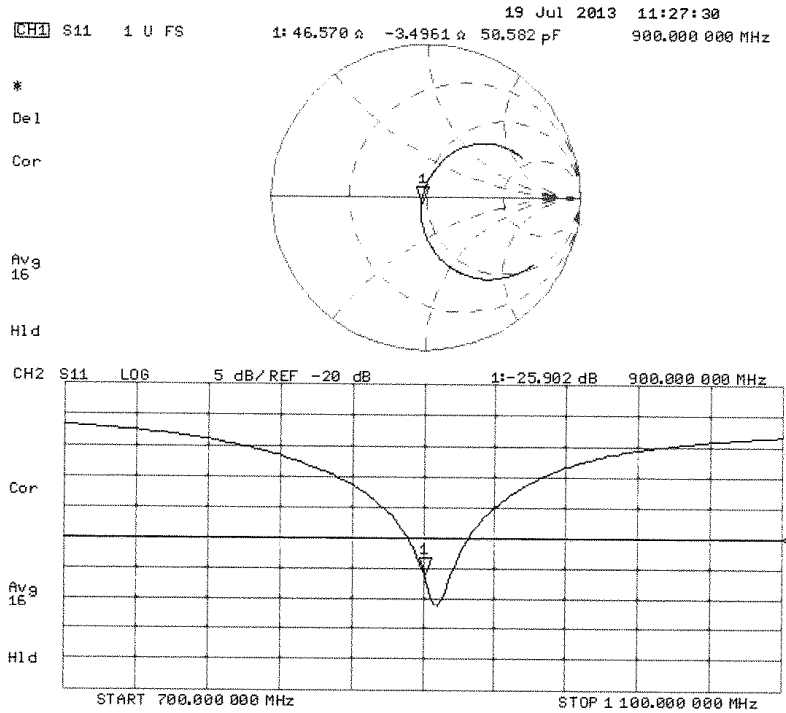

**Calibration Laboratory of
 Schmid & Partner
 Engineering AG**
 Zeughausstrasse 43, 8004 Zurich, Switzerland



S Schweizerischer Kalibrierdienst
S Service suisse d'étalonnage
S Servizio svizzero di taratura
S Swiss Calibration Service

Accredited by the Swiss Accreditation Service (SAS)
 The Swiss Accreditation Service is one of the signatories to the EA
 Multilateral Agreement for the recognition of calibration certificates

Accreditation No.: **SCS 108**

Client **AT4 Wireless**

Certificate No: **D1800V2-2d099_Jul13**

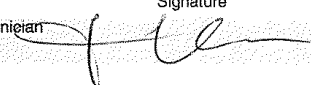
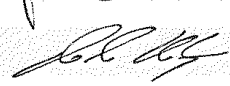
CALIBRATION CERTIFICATE																																															
Object	D1800V2 - SN: 2d099																																														
Calibration procedure(s)	QA CAL-05.v9 Calibration procedure for dipole validation kits above 700 MHz																																														
Calibration date:	July 18, 2013																																														
<p>This calibration certificate documents the traceability to national standards, which realize the physical units of measurements (SI). The measurements and the uncertainties with confidence probability are given on the following pages and are part of the certificate.</p> <p>All calibrations have been conducted in the closed laboratory facility: environment temperature (22 ± 3)°C and humidity < 70%.</p> <p>Calibration Equipment used (M&TE critical for calibration)</p> <table border="1"> <thead> <tr> <th>Primary Standards</th> <th>ID #</th> <th>Cal Date (Certificate No.)</th> <th>Scheduled Calibration</th> </tr> </thead> <tbody> <tr> <td>Power meter EPM-442A</td> <td>GB37480704</td> <td>01-Nov-12 (No. 217-01640)</td> <td>Oct-13</td> </tr> <tr> <td>Power sensor HP 8481A</td> <td>US37292783</td> <td>01-Nov-12 (No. 217-01640)</td> <td>Oct-13</td> </tr> <tr> <td>Reference 20 dB Attenuator</td> <td>SN: 5058 (20k)</td> <td>04-Apr-13 (No. 217-01736)</td> <td>Apr-14</td> </tr> <tr> <td>Type-N mismatch combination</td> <td>SN: 5047.3 / 06327</td> <td>04-Apr-13 (No. 217-01739)</td> <td>Apr-14</td> </tr> <tr> <td>Reference Probe ES3DV3</td> <td>SN: 3205</td> <td>28-Dec-12 (No. ES3-3205_Dec12)</td> <td>Dec-13</td> </tr> <tr> <td>DAE4</td> <td>SN: 601</td> <td>25-Apr-13 (No. DAE4-601_Apr13)</td> <td>Apr-14</td> </tr> </tbody> </table> <table border="1"> <thead> <tr> <th>Secondary Standards</th> <th>ID #</th> <th>Check Date (in house)</th> <th>Scheduled Check</th> </tr> </thead> <tbody> <tr> <td>Power sensor HP 8481A</td> <td>MY41092317</td> <td>18-Oct-02 (in house check Oct-11)</td> <td>In house check: Oct-13</td> </tr> <tr> <td>RF generator R&S SMT-06</td> <td>100005</td> <td>04-Aug-99 (in house check Oct-11)</td> <td>In house check: Oct-13</td> </tr> <tr> <td>Network Analyzer HP 8753E</td> <td>US37390585 S4206</td> <td>18-Oct-01 (in house check Oct-12)</td> <td>In house check: Oct-13</td> </tr> </tbody> </table>				Primary Standards	ID #	Cal Date (Certificate No.)	Scheduled Calibration	Power meter EPM-442A	GB37480704	01-Nov-12 (No. 217-01640)	Oct-13	Power sensor HP 8481A	US37292783	01-Nov-12 (No. 217-01640)	Oct-13	Reference 20 dB Attenuator	SN: 5058 (20k)	04-Apr-13 (No. 217-01736)	Apr-14	Type-N mismatch combination	SN: 5047.3 / 06327	04-Apr-13 (No. 217-01739)	Apr-14	Reference Probe ES3DV3	SN: 3205	28-Dec-12 (No. ES3-3205_Dec12)	Dec-13	DAE4	SN: 601	25-Apr-13 (No. DAE4-601_Apr13)	Apr-14	Secondary Standards	ID #	Check Date (in house)	Scheduled Check	Power sensor HP 8481A	MY41092317	18-Oct-02 (in house check Oct-11)	In house check: Oct-13	RF generator R&S SMT-06	100005	04-Aug-99 (in house check Oct-11)	In house check: Oct-13	Network Analyzer HP 8753E	US37390585 S4206	18-Oct-01 (in house check Oct-12)	In house check: Oct-13
Primary Standards	ID #	Cal Date (Certificate No.)	Scheduled Calibration																																												
Power meter EPM-442A	GB37480704	01-Nov-12 (No. 217-01640)	Oct-13																																												
Power sensor HP 8481A	US37292783	01-Nov-12 (No. 217-01640)	Oct-13																																												
Reference 20 dB Attenuator	SN: 5058 (20k)	04-Apr-13 (No. 217-01736)	Apr-14																																												
Type-N mismatch combination	SN: 5047.3 / 06327	04-Apr-13 (No. 217-01739)	Apr-14																																												
Reference Probe ES3DV3	SN: 3205	28-Dec-12 (No. ES3-3205_Dec12)	Dec-13																																												
DAE4	SN: 601	25-Apr-13 (No. DAE4-601_Apr13)	Apr-14																																												
Secondary Standards	ID #	Check Date (in house)	Scheduled Check																																												
Power sensor HP 8481A	MY41092317	18-Oct-02 (in house check Oct-11)	In house check: Oct-13																																												
RF generator R&S SMT-06	100005	04-Aug-99 (in house check Oct-11)	In house check: Oct-13																																												
Network Analyzer HP 8753E	US37390585 S4206	18-Oct-01 (in house check Oct-12)	In house check: Oct-13																																												
Calibrated by:	Name Jeton Kastrati	Function Laboratory Technician	Signature 																																												
Approved by:	Name Katja Pokovic	Function Technical Manager	Signature 																																												
			Issued: July 19, 2013																																												
This calibration certificate shall not be reproduced except in full without written approval of the laboratory.																																															

**Calibration Laboratory of
Schmid & Partner
Engineering AG**
Zeughausstrasse 43, 8004 Zurich, Switzerland



S Schweizerischer Kallbrierdienst
C Service suisse d'étalonnage
S Servizio svizzero di taratura
S Swiss Calibration Service

Accredited by the Swiss Accreditation Service (SAS)
The Swiss Accreditation Service is one of the signatories to the EA
Multilateral Agreement for the recognition of calibration certificates

Accreditation No.: **SCS 108**

Glossary:

TSL	tissue simulating liquid
ConvF	sensitivity in TSL / NORM x,y,z
N/A	not applicable or not measured

Calibration is Performed According to the Following Standards:

- IEEE Std 1528-2003, "IEEE Recommended Practice for Determining the Peak Spatial-Averaged Specific Absorption Rate (SAR) in the Human Head from Wireless Communications Devices: Measurement Techniques", December 2003
- IEC 62209-1, "Procedure to measure the Specific Absorption Rate (SAR) for hand-held devices used in close proximity to the ear (frequency range of 300 MHz to 3 GHz)", February 2005
- Federal Communications Commission Office of Engineering & Technology (FCC OET), "Evaluating Compliance with FCC Guidelines for Human Exposure to Radiofrequency Electromagnetic Fields; Additional Information for Evaluating Compliance of Mobile and Portable Devices with FCC Limits for Human Exposure to Radiofrequency Emissions", Supplement C (Edition 01-01) to Bulletin 65

Additional Documentation:

- DASY4/5 System Handbook

Methods Applied and Interpretation of Parameters:

- Measurement Conditions:* Further details are available from the Validation Report at the end of the certificate. All figures stated in the certificate are valid at the frequency indicated.
- Antenna Parameters with TSL:* The dipole is mounted with the spacer to position its feed point exactly below the center marking of the flat phantom section, with the arms oriented parallel to the body axis.
- Feed Point Impedance and Return Loss:* These parameters are measured with the dipole positioned under the liquid filled phantom. The impedance stated is transformed from the measurement at the SMA connector to the feed point. The Return Loss ensures low reflected power. No uncertainty required.
- Electrical Delay:* One-way delay between the SMA connector and the antenna feed point. No uncertainty required.
- SAR measured:* SAR measured at the stated antenna input power.
- SAR normalized:* SAR as measured, normalized to an input power of 1 W at the antenna connector.
- SAR for nominal TSL parameters:* The measured TSL parameters are used to calculate the nominal SAR result.

The reported uncertainty of measurement is stated as the standard uncertainty of measurement multiplied by the coverage factor $k=2$, which for a normal distribution corresponds to a coverage probability of approximately 95%.

Measurement Conditions

DASY system configuration, as far as not given on page 1.

DASY Version	DASY5	V52.8.7
Extrapolation	Advanced Extrapolation	
Phantom	Modular Flat Phantom	
Distance Dipole Center - TSL	10 mm	with Spacer
Zoom Scan Resolution	dx, dy, dz = 5 mm	
Frequency	1800 MHz ± 1 MHz	

Head TSL parameters

The following parameters and calculations were applied.

	Temperature	Permittivity	Conductivity
Nominal Head TSL parameters	22.0 °C	40.0	1.40 mho/m
Measured Head TSL parameters	(22.0 ± 0.2) °C	38.7 ± 6 %	1.37 mho/m ± 6 %
Head TSL temperature change during test	< 0.5 °C	----	----

SAR result with Head TSL

SAR averaged over 1 cm ³ (1 g) of Head TSL	Condition	
SAR measured	250 mW input power	9.67 W/kg
SAR for nominal Head TSL parameters	normalized to 1W	38.9 W/kg ± 17.0 % (k=2)

SAR averaged over 10 cm ³ (10 g) of Head TSL	condition	
SAR measured	250 mW input power	5.08 W/kg
SAR for nominal Head TSL parameters	normalized to 1W	20.4 W/kg ± 16.5 % (k=2)

Body TSL parameters

The following parameters and calculations were applied.

	Temperature	Permittivity	Conductivity
Nominal Body TSL parameters	22.0 °C	53.3	1.52 mho/m
Measured Body TSL parameters	(22.0 ± 0.2) °C	51.4 ± 6 %	1.53 mho/m ± 6 %
Body TSL temperature change during test	< 0.5 °C	----	----

SAR result with Body TSL

SAR averaged over 1 cm ³ (1 g) of Body TSL	Condition	
SAR measured	250 mW input power	10.0 W/kg
SAR for nominal Body TSL parameters	normalized to 1W	39.5 W/kg ± 17.0 % (k=2)

SAR averaged over 10 cm ³ (10 g) of Body TSL	condition	
SAR measured	250 mW input power	5.30 W/kg
SAR for nominal Body TSL parameters	normalized to 1W	21.0 W/kg ± 16.5 % (k=2)

Appendix

Antenna Parameters with Head TSL

Impedance, transformed to feed point	50.1 Ω - 4.2 j Ω
Return Loss	- 27.5 dB

Antenna Parameters with Body TSL

Impedance, transformed to feed point	46.4 Ω - 4.0 j Ω
Return Loss	- 25.2 dB

General Antenna Parameters and Design

Electrical Delay (one direction)	1.206 ns
----------------------------------	----------

After long term use with 100W radiated power, only a slight warming of the dipole near the feedpoint can be measured.

The dipole is made of standard semirigid coaxial cable. The center conductor of the feeding line is directly connected to the second arm of the dipole. The antenna is therefore short-circuited for DC-signals. On some of the dipoles, small end caps are added to the dipole arms in order to improve matching when loaded according to the position as explained in the "Measurement Conditions" paragraph. The SAR data are not affected by this change. The overall dipole length is still according to the Standard.

No excessive force must be applied to the dipole arms, because they might bend or the soldered connections near the feedpoint may be damaged.

Additional EUT Data

Manufactured by	SPEAG
Manufactured on	January 30, 2004

DASY5 Validation Report for Head TSL

Date: 18.07.2013

Test Laboratory: SPEAG, Zurich, Switzerland

DUT: Dipole 1800 MHz; Type: D1800V2; Serial: D1800V2 - SN: 2d099

Communication System: UID 0 - CW ; Frequency: 1800 MHz

Medium parameters used: $f = 1800$ MHz; $\sigma = 1.37$ S/m; $\epsilon_r = 38.7$; $\rho = 1000$ kg/m³

Phantom section: Flat Section

Measurement Standard: DASY5 (IEEE/IEC/ANSI C63.19-2007)

DASY52 Configuration:

- Probe: ES3DV3 - SN3205; ConvF(5.04, 5.04, 5.04); Calibrated: 28.12.2012;
- Sensor-Surface: 3mm (Mechanical Surface Detection)
- Electronics: DAE4 Sn601; Calibrated: 25.04.2013
- Phantom: Flat Phantom 5.0 (front); Type: QD000P50AA; Serial: 1001
- DASY52 52.8.7(1137); SEMCAD X 14.6.10(7164)

Dipole Calibration for Head Tissue 2/Pin=250 mW, d=10mm/Zoom Scan (7x7x7)/Cube 0:

Measurement grid: dx=5mm, dy=5mm, dz=5mm

Reference Value = 96.245 V/m; Power Drift = 0.05 dB

Peak SAR (extrapolated) = 17.6 W/kg

SAR(1 g) = 9.67 W/kg; SAR(10 g) = 5.08 W/kg

Maximum value of SAR (measured) = 11.9 W/kg

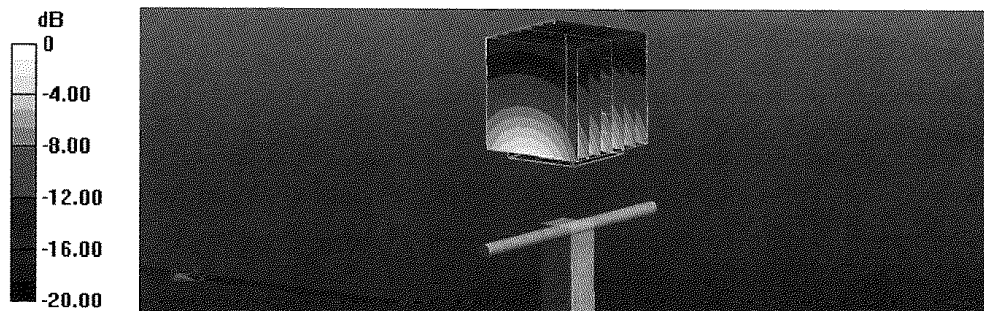

0 dB = 11.9 W/kg = 10.76 dBW/kg

Impedance Measurement Plot for Head TSL

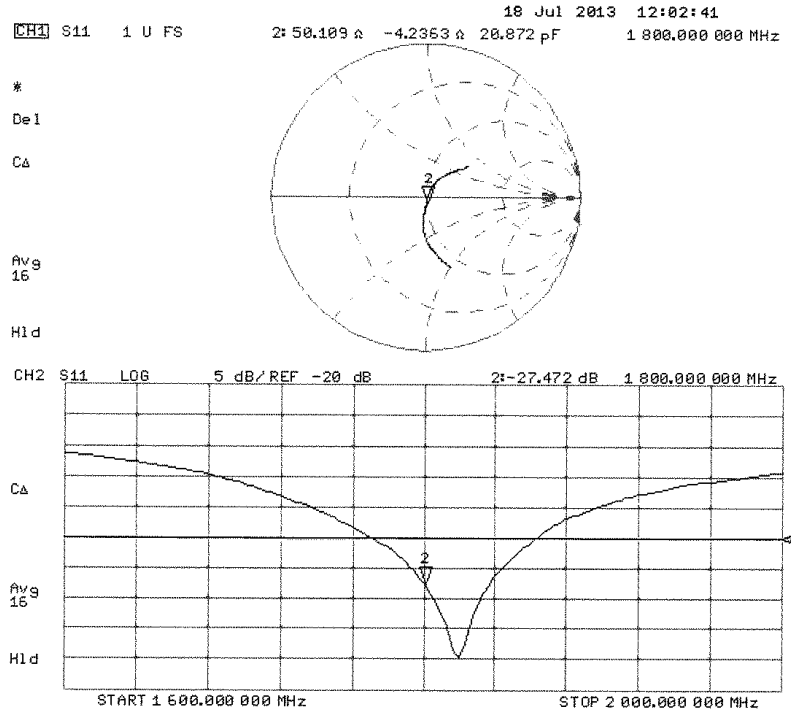

DASY5 Validation Report for Body TSL

Date: 18.07.2013

Test Laboratory: SPEAG, Zurich, Switzerland

DUT: Dipole 1800 MHz; Type: D1800V2; Serial: D1800V2 - SN: 2d099

Communication System: UID 0 - CW ; Frequency: 1800 MHz

Medium parameters used: $f = 1800$ MHz; $\sigma = 1.53$ S/m; $\epsilon_r = 51.4$; $\rho = 1000$ kg/m³

Phantom section: Flat Section

Measurement Standard: DASY5 (IEEE/IEC/ANSI C63.19-2007)

DASY52 Configuration:

- Probe: ES3DV3 - SN3205; ConvF(4.73, 4.73, 4.73); Calibrated: 28.12.2012;
- Sensor-Surface: 3mm (Mechanical Surface Detection)
- Electronics: DAE4 Sn601; Calibrated: 25.04.2013
- Phantom: Flat Phantom 5.0 (back); Type: QD000P50AA; Serial: 1002
- DASY52 52.8.7(1137); SEMCAD X 14.6.10(7164)

Dipole Calibration for Body Tissue/Pin=250 mW, d=10mm/Zoom Scan (7x7x7)/Cube 0:

Measurement grid: dx=5mm, dy=5mm, dz=5mm

Reference Value = 93.813 V/m; Power Drift = 0.02 dB

Peak SAR (extrapolated) = 17.9 W/kg

SAR(1 g) = 10 W/kg; SAR(10 g) = 5.3 W/kg

Maximum value of SAR (measured) = 12.5 W/kg

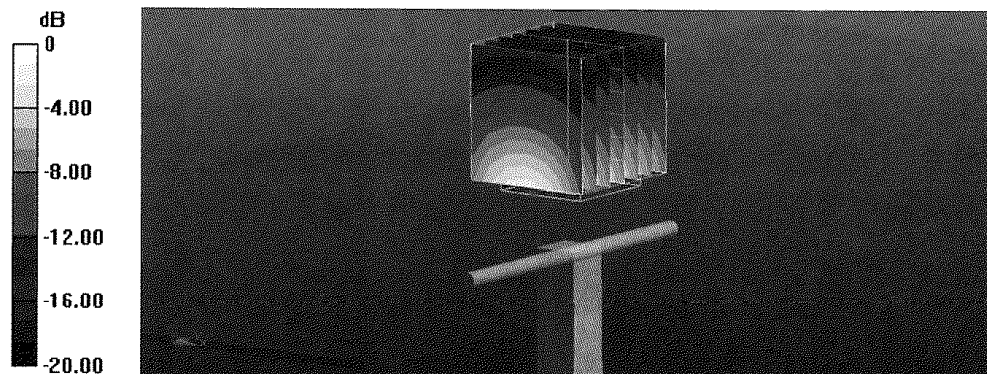

0 dB = 12.5 W/kg = 10.97 dBW/kg

Impedance Measurement Plot for Body TSL

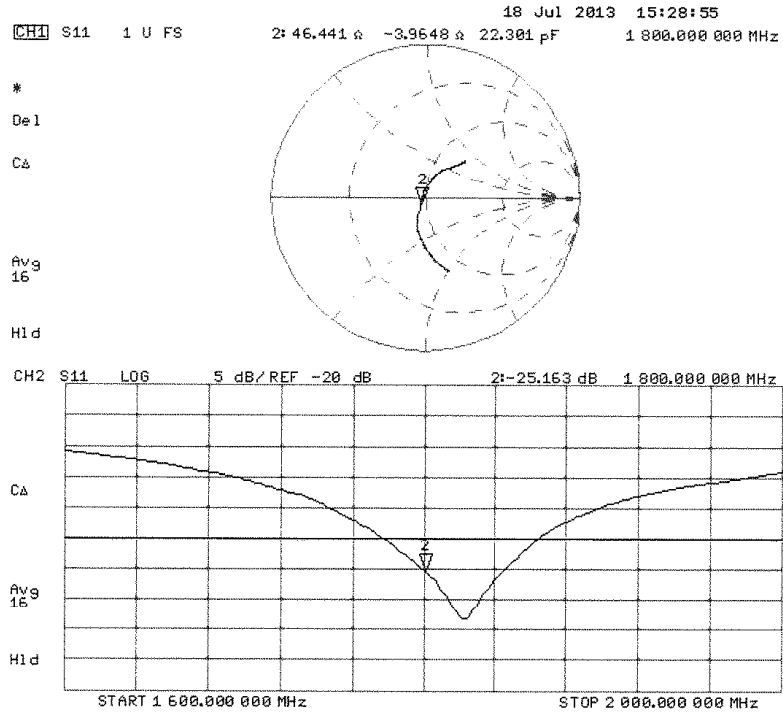

**Calibration Laboratory of
 Schmid & Partner
 Engineering AG**
 Zeughausstrasse 43, 8004 Zurich, Switzerland



S Schweizerischer Kalibrierdienst
C Service suisse d'étalonnage
S Servizio svizzero di taratura
S Swiss Calibration Service

Accredited by the Swiss Accreditation Service (SAS)
 The Swiss Accreditation Service is one of the signatories to the EA
 Multilateral Agreement for the recognition of calibration certificates

Accreditation No.: **SCS 108**

Client **AT4 Wireless**

Certificate No: **D2450V2-756_Jul13**

CALIBRATION CERTIFICATE

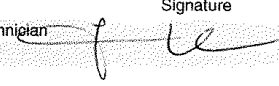
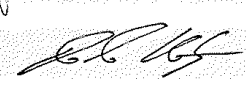
Object	D2450V2 - SN: 756		
Calibration procedure(s)	QA CAL-05.v9 Calibration procedure for dipole validation kits above 700 MHz		
Calibration date:	July 22, 2013		
<p>This calibration certificate documents the traceability to national standards, which realize the physical units of measurements (SI). The measurements and the uncertainties with confidence probability are given on the following pages and are part of the certificate.</p> <p>All calibrations have been conducted in the closed laboratory facility: environment temperature (22 ± 3)°C and humidity < 70%.</p> <p>Calibration Equipment used (M&TE critical for calibration)</p>			
Primary Standards	ID #	Cal Date (Certificate No.)	Scheduled Calibration
Power meter EPM-442A	GB37480704	01-Nov-12 (No. 217-01640)	Oct-13
Power sensor HP 8481A	US37292783	01-Nov-12 (No. 217-01640)	Oct-13
Reference 20 dB Attenuator	SN: 5058 (20k)	04-Apr-13 (No. 217-01736)	Apr-14
Type-N mismatch combination	SN: 5047.3 / 06327	04-Apr-13 (No. 217-01739)	Apr-14
Reference Probe ES3DV3	SN: 3205	28-Dec-12 (No. ES3-3205_Dec12)	Dec-13
DAE4	SN: 601	25-Apr-13 (No. DAE4-601_Apr13)	Apr-14
Secondary Standards	ID #	Check Date (in house)	Scheduled Check
Power sensor HP 8481A	MY41092317	18-Oct-02 (in house check Oct-11)	In house check: Oct-13
RF generator R&S SMT-06	100005	04-Aug-99 (in house check Oct-11)	In house check: Oct-13
Network Analyzer HP 8753E	US37390585 S4206	18-Oct-01 (in house check Oct-12)	In house check: Oct-13
Calibrated by:	Name Jeton Kastrati	Function Laboratory Technician	Signature 
Approved by:	Name Katja Pokovic	Function Technical Manager	Signature 
			Issued: July 22, 2013
This calibration certificate shall not be reproduced except in full without written approval of the laboratory.			

Calibration Laboratory of
Schmid & Partner
Engineering AG
Zeughausstrasse 43, 8004 Zurich, Switzerland



S Schweizerischer Kalibrierdienst
C Service suisse d'étalonnage
S Servizio svizzero di taratura
S Swiss Calibration Service

Accredited by the Swiss Accreditation Service (SAS)
The Swiss Accreditation Service is one of the signatories to the EA
Multilateral Agreement for the recognition of calibration certificates

Accreditation No.: **SCS 108**

Glossary:

TSL tissue simulating liquid
ConvF sensitivity in TSL / NORM x,y,z
N/A not applicable or not measured

Calibration is Performed According to the Following Standards:

- a) IEEE Std 1528-2003, "IEEE Recommended Practice for Determining the Peak Spatial-Averaged Specific Absorption Rate (SAR) in the Human Head from Wireless Communications Devices: Measurement Techniques", December 2003
- b) IEC 62209-1, "Procedure to measure the Specific Absorption Rate (SAR) for hand-held devices used in close proximity to the ear (frequency range of 300 MHz to 3 GHz)", February 2005
- c) Federal Communications Commission Office of Engineering & Technology (FCC OET), "Evaluating Compliance with FCC Guidelines for Human Exposure to Radiofrequency Electromagnetic Fields; Additional Information for Evaluating Compliance of Mobile and Portable Devices with FCC Limits for Human Exposure to Radiofrequency Emissions", Supplement C (Edition 01-01) to Bulletin 65

Additional Documentation:

- d) DASY4/5 System Handbook

Methods Applied and Interpretation of Parameters:

- *Measurement Conditions:* Further details are available from the Validation Report at the end of the certificate. All figures stated in the certificate are valid at the frequency indicated.
- *Antenna Parameters with TSL:* The dipole is mounted with the spacer to position its feed point exactly below the center marking of the flat phantom section, with the arms oriented parallel to the body axis.
- *Feed Point Impedance and Return Loss:* These parameters are measured with the dipole positioned under the liquid filled phantom. The impedance stated is transformed from the measurement at the SMA connector to the feed point. The Return Loss ensures low reflected power. No uncertainty required.
- *Electrical Delay:* One-way delay between the SMA connector and the antenna feed point. No uncertainty required.
- *SAR measured:* SAR measured at the stated antenna input power.
- *SAR normalized:* SAR as measured, normalized to an input power of 1 W at the antenna connector.
- *SAR for nominal TSL parameters:* The measured TSL parameters are used to calculate the nominal SAR result.

The reported uncertainty of measurement is stated as the standard uncertainty of measurement multiplied by the coverage factor $k=2$, which for a normal distribution corresponds to a coverage probability of approximately 95%.

Measurement Conditions

DASY system configuration, as far as not given on page 1.

DASY Version	DASY5	V52.8.7
Extrapolation	Advanced Extrapolation	
Phantom	Modular Flat Phantom	
Distance Dipole Center - TSL	10 mm	with Spacer
Zoom Scan Resolution	dx, dy, dz = 5 mm	
Frequency	2450 MHz ± 1 MHz	

Head TSL parameters

The following parameters and calculations were applied.

	Temperature	Permittivity	Conductivity
Nominal Head TSL parameters	22.0 °C	39.2	1.80 mho/m
Measured Head TSL parameters	(22.0 ± 0.2) °C	37.8 ± 6 %	1.81 mho/m ± 6 %
Head TSL temperature change during test	< 0.5 °C	----	----

SAR result with Head TSL

SAR averaged over 1 cm ³ (1 g) of Head TSL	Condition	
SAR measured	250 mW input power	13.4 W/kg
SAR for nominal Head TSL parameters	normalized to 1W	53.0 W/kg ± 17.0 % (k=2)

SAR averaged over 10 cm ³ (10 g) of Head TSL	condition	
SAR measured	250 mW input power	6.20 W/kg
SAR for nominal Head TSL parameters	normalized to 1W	24.6 W/kg ± 16.5 % (k=2)

Body TSL parameters

The following parameters and calculations were applied.

	Temperature	Permittivity	Conductivity
Nominal Body TSL parameters	22.0 °C	52.7	1.95 mho/m
Measured Body TSL parameters	(22.0 ± 0.2) °C	50.5 ± 6 %	2.01 mho/m ± 6 %
Body TSL temperature change during test	< 0.5 °C	----	----

SAR result with Body TSL

SAR averaged over 1 cm ³ (1 g) of Body TSL	Condition	
SAR measured	250 mW input power	13.1 W/kg
SAR for nominal Body TSL parameters	normalized to 1W	51.1 W/kg ± 17.0 % (k=2)

SAR averaged over 10 cm ³ (10 g) of Body TSL	condition	
SAR measured	250 mW input power	6.06 W/kg
SAR for nominal Body TSL parameters	normalized to 1W	23.9 W/kg ± 16.5 % (k=2)

Appendix

Antenna Parameters with Head TSL

Impedance, transformed to feed point	$56.2 \Omega + 2.2 j\Omega$
Return Loss	- 24.2 dB

Antenna Parameters with Body TSL

Impedance, transformed to feed point	$51.8 \Omega + 3.8 j\Omega$
Return Loss	- 27.8 dB

General Antenna Parameters and Design

Electrical Delay (one direction)	1.157 ns
----------------------------------	----------

After long term use with 100W radiated power, only a slight warming of the dipole near the feedpoint can be measured.

The dipole is made of standard semirigid coaxial cable. The center conductor of the feeding line is directly connected to the second arm of the dipole. The antenna is therefore short-circuited for DC-signals. On some of the dipoles, small end caps are added to the dipole arms in order to improve matching when loaded according to the position as explained in the "Measurement Conditions" paragraph. The SAR data are not affected by this change. The overall dipole length is still according to the Standard.

No excessive force must be applied to the dipole arms, because they might bend or the soldered connections near the feedpoint may be damaged.

Additional EUT Data

Manufactured by	SPEAG
Manufactured on	April 22, 2004

DASY5 Validation Report for Head TSL

Date: 22.07.2013

Test Laboratory: SPEAG, Zurich, Switzerland

DUT: Dipole 2450 MHz; Type: D2450V2; Serial: D2450V2 - SN: 756

Communication System: UID 0 - CW ; Frequency: 2450 MHz
Medium parameters used: $f = 2450$ MHz; $\sigma = 1.81$ S/m; $\epsilon_r = 37.8$; $\rho = 1000$ kg/m³
Phantom section: Flat Section
Measurement Standard: DASY5 (IEEE/IEC/ANSI C63.19-2007)

DASY52 Configuration:

- Probe: ES3DV3 - SN3205; ConvF(4.52, 4.52, 4.52); Calibrated: 28.12.2012;
- Sensor-Surface: 3mm (Mechanical Surface Detection)
- Electronics: DAE4 Sn601; Calibrated: 25.04.2013
- Phantom: Flat Phantom 5.0 (front); Type: QD000P50AA; Serial: 1001
- DASY52 52.8.7(1137); SEMCAD X 14.6.10(7164)

Dipole Calibration for Head Tissue/Pin=250 mW, d=10mm/Zoom Scan (7x7x7)/Cube 0:

Measurement grid: $dx=5$ mm, $dy=5$ mm, $dz=5$ mm
Reference Value = 95.304 V/m; Power Drift = 0.04 dB
Peak SAR (extrapolated) = 27.7 W/kg
SAR(1 g) = 13.4 W/kg; SAR(10 g) = 6.2 W/kg
Maximum value of SAR (measured) = 17.1 W/kg

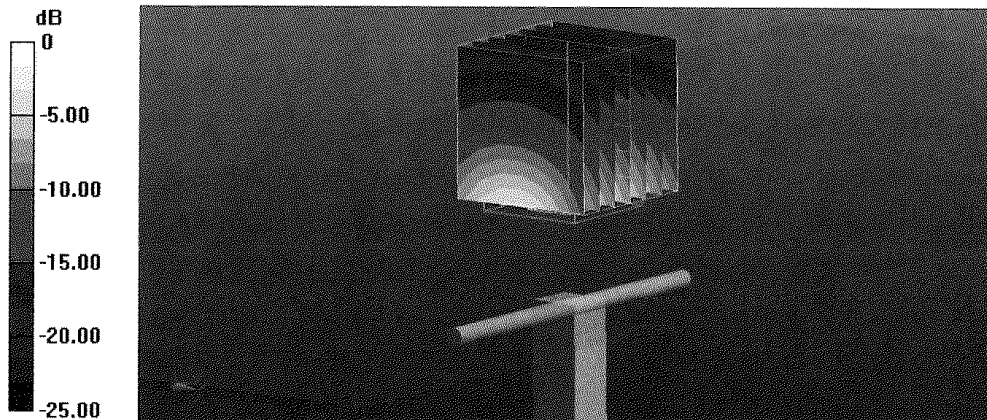

0 dB = 17.1 W/kg = 12.33 dBW/kg

Impedance Measurement Plot for Head TSL

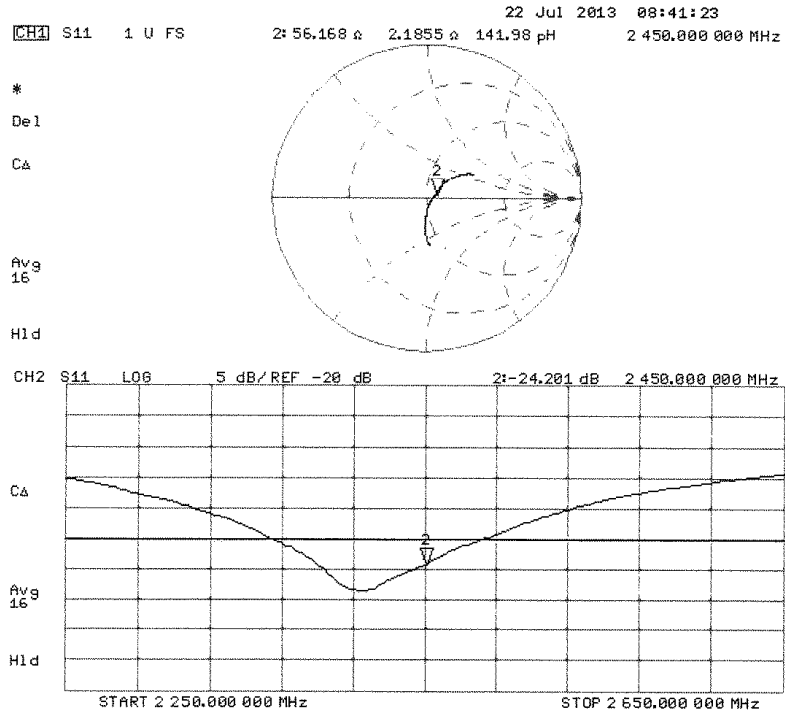

DASY5 Validation Report for Body TSL

Date: 19.07.2013

Test Laboratory: SPEAG, Zurich, Switzerland

DUT: Dipole 2450 MHz; Type: D2450V2; Serial: D2450V2 - SN: 756

Communication System: UID 0 - CW ; Frequency: 2450 MHz
Medium parameters used: $f = 2450$ MHz; $\sigma = 2.01$ S/m; $\epsilon_r = 50.5$; $\rho = 1000$ kg/m³
Phantom section: Flat Section
Measurement Standard: DASY5 (IEEE/IEC/ANSI C63.19-2007)

DASY52 Configuration:

- Probe: ES3DV3 - SN3205; ConvF(4.42, 4.42, 4.42); Calibrated: 28.12.2012;
- Sensor-Surface: 3mm (Mechanical Surface Detection)
- Electronics: DAE4 Sn601; Calibrated: 25.04.2013
- Phantom: Flat Phantom 5.0 (back); Type: QD000P50AA; Serial: 1002
- DASY52 52.8.7(1137); SEMCAD X 14.6.10(7164)

Dipole Calibration for Body Tissue/Pin=250 mW, d=10mm/Zoom Scan (7x7x7)/Cube 0:

Measurement grid: dx=5mm, dy=5mm, dz=5mm
Reference Value = 95.304 V/m; Power Drift = 0.01 dB
Peak SAR (extrapolated) = 27.3 W/kg
SAR(1 g) = 13.1 W/kg; SAR(10 g) = 6.06 W/kg
Maximum value of SAR (measured) = 17.2 W/kg

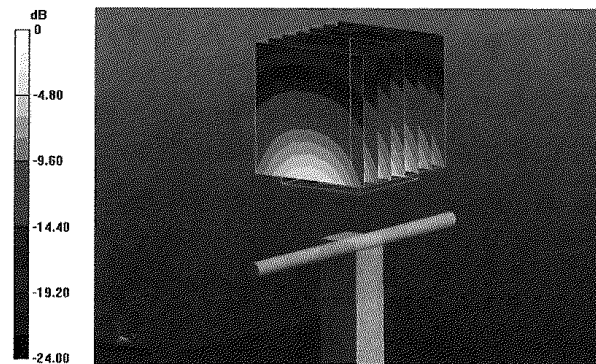

0 dB = 17.2 W/kg = 12.36 dBW/kg

Impedance Measurement Plot for Body TSL

