

# NORA-B1 series

Stand-alone dual-core Bluetooth 5 low energy and IEEE 802.15.4 module

System integration manual

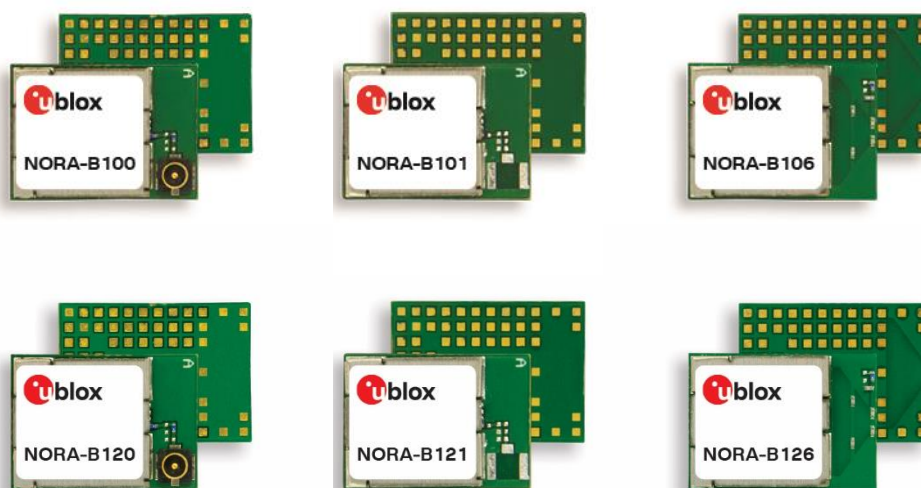

## Abstract

This document describes the system integration of the NORA-B1 series stand-alone Bluetooth® 5.2 Low Energy and IEEE 802.15.4 modules.

# Document information

<b>Title</b>	<b>NORA-B1 series</b>	
<b>Subtitle</b>	Stand-alone dual-core Bluetooth 5 low energy and IEEE 802.15.4 module	
<b>Document type</b>	System integration manual	
<b>Document number</b>	UBX-20027617	
<b>Revision and date</b>	R09	27-Jan-2023
<b>Disclosure restriction</b>	C1-Public	

## Document status descriptions

Draft	For functional testing. Revised and supplementary data will be published later.
Objective specification	Target values. Revised and supplementary data will be published later.
Advance information	Data based on early testing. Revised and supplementary data will be published later.
Early production information	Data from product verification. Revised and supplementary data may be published later.
Production information	Document contains the final product specification.

This document applies to the following products:

Product name	Document status
NORA-B100	Early production information
NORA-B101	Early production information
NORA-B106	Early production information
NORA-B120	Early production information
NORA-B121	Early production information
NORA-B126	Early production information

For information about the related hardware, software, and status of listed product types, see also the NORA-B1 data sheet [\[1\]](#).

u-blox or third parties may hold intellectual property rights in the products, names, logos and designs included in this document. Copying, reproduction, modification or disclosure to third parties of this document or any part thereof is only permitted with the express written permission of u-blox.

The information contained herein is provided "as is" and u-blox assumes no liability for its use. No warranty, either express or implied, is given, including but not limited to, with respect to the accuracy, correctness, reliability and fitness for a particular purpose of the information. This document may be revised by u-blox at any time without notice. For the most recent documents, visit [www.u-blox.com](http://www.u-blox.com).

Copyright © u-blox AG.

# Contents

<b>Document information</b> .....	<b>2</b>
<b>Contents</b> .....	<b>3</b>
<b>1 System description</b> .....	<b>7</b>
1.1 Overview.....	7
1.2 Applications .....	7
1.3 Architecture .....	8
1.3.1 Block diagram .....	8
1.3.2 Hardware options .....	9
1.3.3 Software options .....	9
1.4 Pin assignments.....	9
1.5 Supply interfaces .....	9
1.5.1 Main supply input .....	9
1.5.2 Digital I/O interfaces reference voltage .....	11
1.5.3 USB supply input.....	11
1.5.4 VDD/VDDH application circuits .....	11
1.6 System function interfaces .....	12
1.6.1 Module reset .....	12
1.6.2 Internal temperature sensor .....	12
1.7 Debug.....	12
1.7.1 Serial Wire Debug (SWD) .....	12
1.8 GPIO pins.....	12
1.9 Analog interfaces .....	13
1.9.1 ADC.....	13
1.9.2 Comparator .....	13
1.9.3 Low power comparator .....	13
1.9.4 Analog pin options .....	14
1.10 Serial interfaces .....	14
1.10.1 Universal Asynchronous Receiver/Transmitter (UART).....	14
1.10.2 Serial Peripheral Interface (SPI).....	14
1.10.3 Quad Serial Peripheral Interface (QSPI) .....	15
1.10.4 Inter-Integrated Circuit (I2C) interface .....	15
1.10.5 Pulse Width Modulation (PWM) interface.....	16
1.10.6 Inter-IC Sound (I2S) interface .....	16
1.10.7 Pulse Density Modulation (PDM) interface .....	16
1.10.8 USB 2.0 device interface .....	16
1.11 Antenna interface .....	16
1.11.1 U.FL connector – NORA-B100 and NORA-B120.....	16
1.11.2 Antenna pin – NORA-B101 and NORA-B121 .....	16
1.11.3 Integrated antenna – NORA-B106 and NORA-B126.....	17
1.11.4 NFC antenna .....	17

- 1.12 Reserved pins (RSVD) ..... 17
- 1.13 GND pins ..... 17
- 1.14 FEM control (NORA-B12 only) ..... 18
  - 1.14.1 FEM Hardware ..... 18
  - 1.14.2 FEM enablement ..... 19
- 2 Custom hardware support ..... 20**
- 2.1 Available EVK BSPs ..... 20
- 2.2 BSP files ..... 20
  - 2.2.1 board.cmake ..... 21
  - 2.2.2 CMake ..... 21
  - 2.2.3 Kconfig ..... 21
  - 2.2.4 Device tree ..... 21
  - 2.2.5 YAML ..... 21
  - 2.2.6 Defconfig ..... 21
  - 2.2.7 Helper code ..... 21
  - 2.2.8 Documentation ..... 21
- 3 Software development ..... 22**
- 3.1 Nordic Semiconductor nRF Connect SDK ..... 22
  - 3.1.1 Toolchain Manager ..... 22
  - 3.1.2 Documentation – nRF Connect SDK ..... 22
  - 3.1.3 Support – Nordic Semiconductor DevZone development forum ..... 23
- 3.2 Bluetooth device (MAC) address and other production data ..... 23
- 4 Applications ..... 26**
- 4.1 Application and network core projects ..... 26
- 4.2 Project folder ..... 26
  - 4.2.1 CMakeLists.txt ..... 26
  - 4.2.2 prj.conf ..... 26
  - 4.2.3 board.overlay ..... 26
  - 4.2.4 Source code ..... 27
- 4.3 Example code ..... 27
- 5 Flashing application software ..... 28**
- 5.1 SWD interface ..... 28
- 5.2 Readback protection ..... 28
- 5.3 Recovery ..... 28
- 5.4 Programming ..... 29
- 6 Design-in ..... 30**
- 6.1 Overview ..... 30
- 6.2 Design for NORA family ..... 30
- 6.3 Antenna interface ..... 30
  - 6.3.1 RF transmission line design (NORA-B101 and NORA-B121 only) ..... 31
  - 6.3.2 Antenna design (NORA-B101 and NORA-B121 only) ..... 32
  - 6.3.3 On-board antenna (NORA-B106 and NORA-B126 only) ..... 36

- 6.4 Supply interfaces .....37
  - 6.4.1 Module supply design .....37
- 6.5 Debug interface .....37
- 6.6 Serial interfaces .....38
  - 6.6.1 UART .....38
  - 6.6.2 USB .....38
  - 6.6.3 SPI, QSPI, I2C, I2S, PDM .....39
- 6.7 NFC interface .....39
- 6.8 General high-speed layout guidelines .....40
  - 6.8.1 General considerations for schematic design and PCB floor-planning .....40
  - 6.8.2 Module placement .....41
  - 6.8.3 Layout and manufacturing .....41
- 6.9 Module footprint and paste mask .....41
- 6.10 Thermal guidelines .....42
- 6.11 ESD guidelines .....42
- 7 Handling and soldering ..... 43**
  - 7.1 ESD handling precautions .....43
  - 7.2 Packaging, shipping, storage, and moisture preconditioning .....43
  - 7.3 Soldering .....43
    - 7.3.1 Reflow soldering process .....44
    - 7.3.2 Cleaning .....45
    - 7.3.3 Other remarks .....45
- 8 Regulatory information and requirements ..... 46**
  - 8.1 ETSI – European market (NORA-B12 pending) .....46
    - 8.1.1 Compliance statement .....46
    - 8.1.2 NORA-B1 software security considerations .....46
    - 8.1.3 Output power limitation .....46
    - 8.1.4 Safety Compliance .....47
  - 8.2 FCC/ISED – US/Canadian markets .....47
    - 8.2.1 Compliance statements – US .....47
    - 8.2.2 Compliance statements – Canada .....48
    - 8.2.3 RF Exposure .....49
    - 8.2.4 Antenna selection .....49
    - 8.2.5 End-product verification requirements .....49
    - 8.2.6 End-product labelling requirements .....50
  - 8.3 MIC - Japanese market (NORA-B12 pending) .....52
    - 8.3.1 Compliance statement .....52
    - 8.3.2 48-bit address requirement .....52
    - 8.3.3 End-product labelling requirement .....52
    - 8.3.4 End-product user manual requirement .....53
  - 8.4 NCC – Taiwanese market (NORA-B12 pending) .....53
    - 8.4.1 Compliance statements .....53

8.4.2	End-product labelling requirement .....	53
8.5	KCC – South Korean market (NORA-B12 pending) .....	54
8.5.1	Compliance statement .....	54
8.5.2	End-product labeling requirements .....	54
8.5.3	End-product user manual requirements .....	55
8.6	ANATEL Brazil compliance (NORA-B12 pending) .....	55
8.7	Australia and New Zealand regulatory compliance (NORA-B12 pending) .....	56
8.8	South Africa regulatory compliance (NORA-B12 pending) .....	56
8.9	Integration checklist .....	57
8.10	Pre-approved antennas list .....	58
8.10.1	Antenna accessories .....	58
8.10.2	Single band antennas .....	58
<b>9</b>	<b>Technology standards compliance .....</b>	<b>61</b>
9.1	Bluetooth SIG .....	61
9.2	Matter .....	61
9.3	Thread .....	61
9.4	Zigbee .....	61
9.5	USB .....	61
<b>10</b>	<b>Product testing .....</b>	<b>62</b>
10.1	u-blox in-line production test .....	62
10.2	OEM manufacturer production test .....	63
10.2.1	“Go/No go” tests for integrated devices .....	63
<b>Appendix</b>	<b>.....</b>	<b>64</b>
<b>A</b>	<b>Glossary .....</b>	<b>64</b>
<b>B</b>	<b>Antenna reference designs .....</b>	<b>66</b>
<b>Related documents</b>	<b>.....</b>	<b>67</b>
<b>Revision history</b>	<b>.....</b>	<b>68</b>
<b>Contact</b>	<b>.....</b>	<b>68</b>

# 1 System description

## 1.1 Overview

The NORA-B1 series of small stand-alone, open CPU, modules support Bluetooth 5.2 device connectivity and operate in temperatures of up to 105 °C. The modules are built on the Nordic nRF5340 System on a Chip as an open CPU solution, where customer applications run on two Arm® Cortex®-M33 processor cores with integrated flash and RAM memory. NORA-B12 series also include a Skyworks 66405-11 front end module (FEM) consisting of a transmit power amplifier (PA) and receive low noise amplifier (LNA).

The application core implements TrustZone® technology that includes an Arm Cortex-M33 processor, Digital Signal Processing (DSP) extension, Floating-point Unit (FPU), and CryptoCell™-312 with roots-of-trust and other security mechanisms for IoT and high-performance applications. The processor is clocked at either 128 or 64 Mhz.

The network core includes an Arm® Cortex®-M33 processor with integrated 2.4 GHz radio capable of handling Bluetooth Low Energy (LE), 802.15.4 for Thread and Zigbee, and Nordic proprietary protocols. The processor is clocked at 64 Mhz.

With features like Direction finding (Angle-of-Arrival and Angle-of-Departure), Bluetooth long range, and Bluetooth Low Energy (LE) Audio, NORA-B1 series modules support Bluetooth LE services such as serial port communication, GATT, beacons, and mesh along with a range of wired interfaces, including UART, QSPI, SPI, I2C, I2S, USB, QDEC, PDM, PWM, and ADC.

NORA-B10 series modules support multiple power supply configurations and several available antenna options: U.FL connector (NORA B100), antenna pin (NORA-B101), and on-board PCB trace antenna (NORA-B106).

NORA-B12 series modules support a single power supply configuration and have the same antenna options: U.FL connector (NORA-B120), antenna pin (NORA-B121), and on-board PCB trace antenna (NORA-B126).

## 1.2 Applications

NORA-B1 modules are suitable for a broad range of performance-oriented applications, including:

- Professional lighting
- Industrial automation
- Advanced wearables
- Smart buildings and cities
- Low power sensors
- Wireless-connected and configurable equipment
- Point-of-sale
- Medical and health devices
- Real-time location services (RTLS)
- Indoor positioning
- Asset tracking

## 1.3 Architecture

### 1.3.1 Block diagram

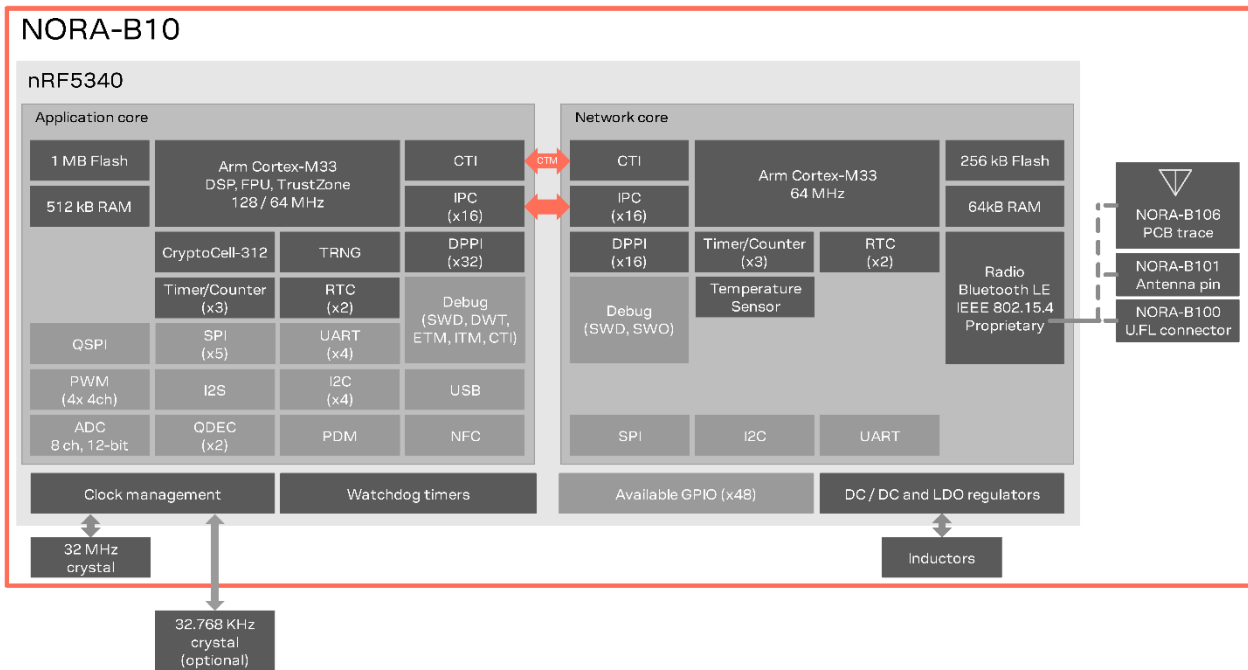

Figure 1: NORA-B10 series block diagram

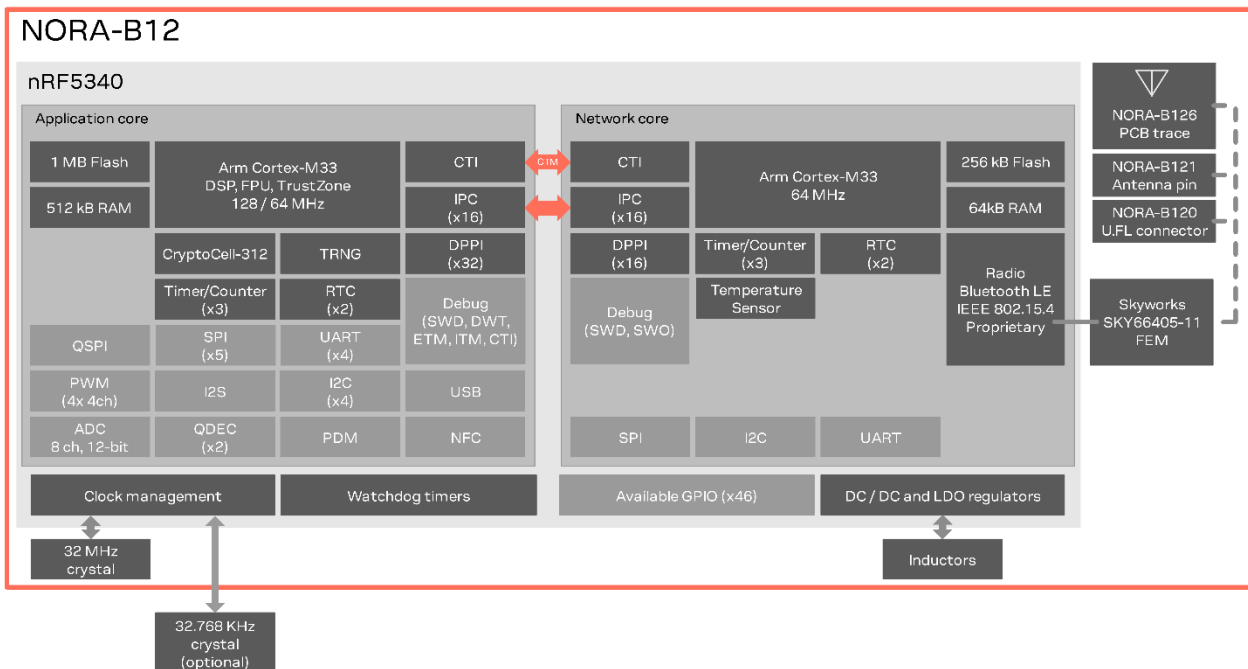

Figure 2: NORA-B12 series block diagram



## 1.3.2 Hardware options

NORA-B1 series modules use an identical hardware configuration except for the different antenna solutions and FEM options. An external 32.768 kHz low-frequency crystal can be used if LFCLK accuracy better than +/-250 ppm is required. DC-DC converters are integrated to provide higher efficiency across operating modes.

## 1.3.3 Software options

NORA-B1 series modules are open CPU solutions that allow custom applications to be developed with the Nordic Semiconductor nRF Connect SDK, which includes the Zephyr Real Time Operating System (RTOS), MCUboot bootloader, and nrfxdrv drivers for optimizing connected peripheral performance.

## 1.4 Pin assignments

For information about the function, configuration, and characteristics of module pins, see the NORA-B1 series data sheet [1].

## 1.5 Supply interfaces

### 1.5.1 Main supply input

#### 1.5.1.1 NORA-B10

NORA-B10 utilizes three power inputs, **VDDH**, **VDD**, and **VBUS**. These inputs connect to internal regulators that provide the application and network core operating voltages, USB subsystem power, and GPIO voltage references.

**Error! Reference source not found.** shows how in normal voltage mode, a single power source is connected to both **VDDH** and **VDD**. This bypasses the high voltage regulator (VREGH). The GPIO voltage is equal to the external power source voltage.

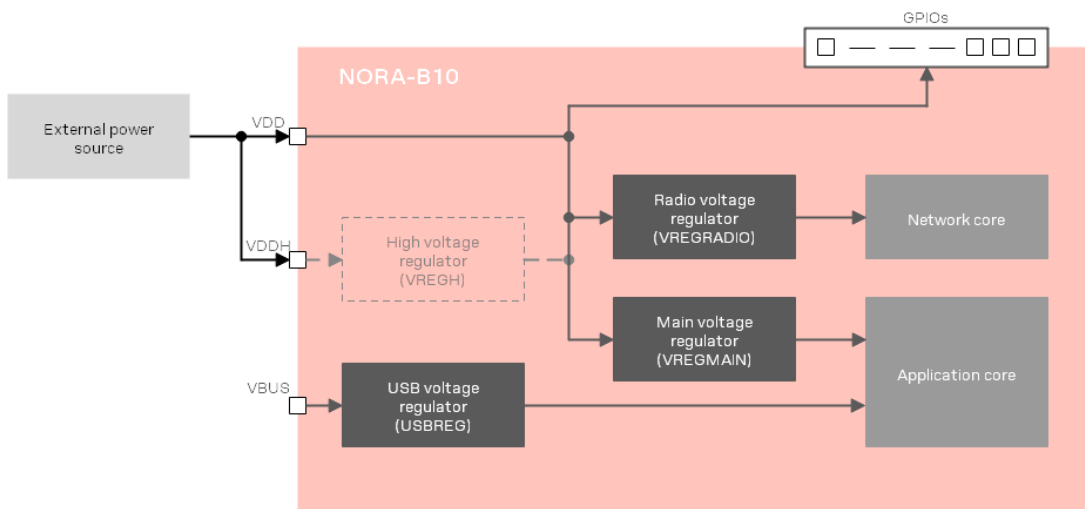
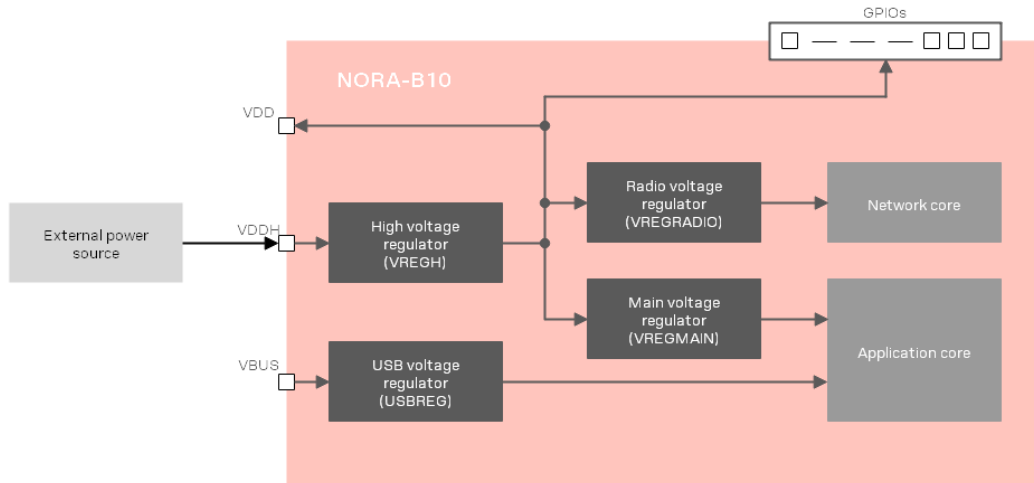

Figure 3: NORA-B10 normal voltage power connection

**Error! Reference source not found.** shows how in high voltage mode, a single power source is connected only to **VDDH**. The high voltage regulator (VREGH) then generates **VDD**, which can be configured between 1.8 and 3.3 VDC through VREGHVOUT in the user information configuration register (UICR) of the application core.



**Figure 4: NORA-B10 high voltage power connection**

The high voltage, radio voltage, and main voltage regulators have both a low drop-out regulator (LDO) and DC-DC converter. No additional components are required to use the DC-DC converters. Once the DC-DC converters are enabled by the application, switching between the LDO and DC-DC converter is automatic based on the required current.

In high voltage mode, VDD can provide a maximum external current of 7 mA (via VDD and GPIO pins) when VREGMAIN and VREGRADIO are in DC-DC mode and a maximum of 1 mA when they are in mode LDO or during System OFF.

### 1.5.1.2 NORA-B12

NORA-B12 utilizes two power inputs, **VDD** and **VBUS**. The **VDDH** pin is internally connected to **VDD**. These inputs connect to internal regulators that provide the application and network core operating voltages, USB subsystem power, and GPIO voltage references.

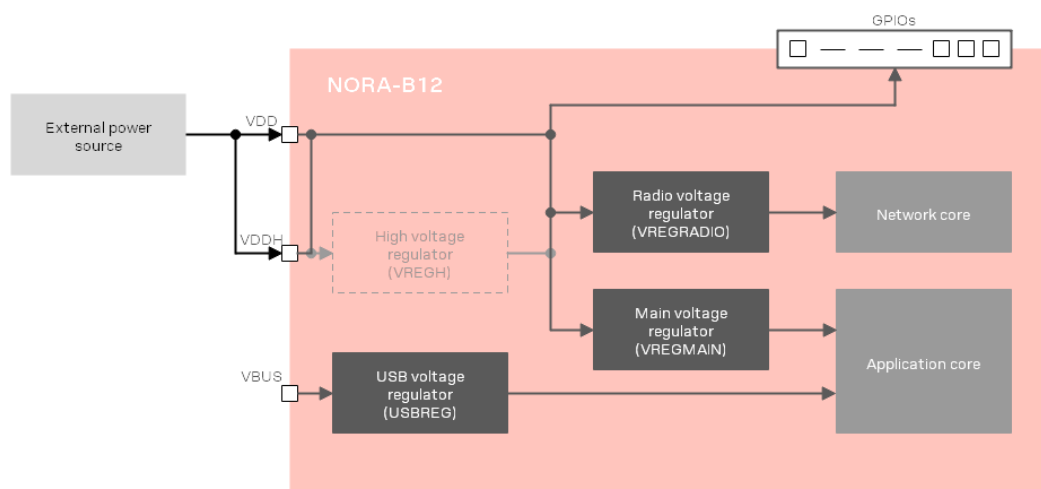

Figure 5: NORA-B12 power connection

One or both of **VDD** and **VDDH** may be connected to the external power source. For NORA-B12, only the normal voltage power mode is supported.

### 1.5.2 Digital I/O interfaces reference voltage

The digital I/O pins operating voltage is equal to **VDD**, regardless of whether it is connected to an external source or generated from the high voltage regulator. As noted above, when in high voltage mode, **VDD** voltage is configured through the VREGHVOUT register in the application core UICR.

### 1.5.3 USB supply input

If used by the application, apply the VBUS power from the upstream USB host port to the **VBUS** pin. The USB voltage regulator is a 3.3 V LDO regulator used to power the USB subsystem and provide a reference voltage for the **USB\_DP** and **USB\_DM** signals.

### 1.5.4 VDD/VDDH application circuits

The power for NORA-B1 series modules is provided through the **VDD** and **VDDH** pins. The power can be taken from any of the following sources:

- Switching Mode Power Supply (SMPS)
- Low Drop Out (LDO) regulator
- Battery

An SMPS is the ideal choice when the available primary supply source has a higher value than the operating supply voltage of NORA-B1 series modules. The use of SMPS provides the best power efficiency for the overall application and minimizes the current drawn from the main supply source.

 When using an SMPS source, ensure that the AC voltage ripple at the switching frequency is kept as low as possible. The layout must be implemented to minimize impact of high frequency ringing.

The use of an LDO linear regulator is convenient for a primary supply with a relatively low voltage where the typical 85-90% efficiency of the switching regulator leads to minimal current saving. Linear regulators are not recommended for high voltage step-down, as they dissipate a considerable amount of energy.

DC-DC efficiency should be evaluated as a tradeoff between active and idle duty cycles of the specific application. Although some DC-DC conversion can be efficient for extremely light loads, DC-DC conversion efficiency quickly degrades as the idle current drops below a few milliamps (mA), which significantly reduces the battery life.

Due to the low current consumption and wide voltage range of NORA-B10, a battery can be used as the main supply. The capacity of the battery should be selected to match the application. Care should be taken to ensure that the battery can deliver the peak current required by the module. See the NORA-B1 series data sheet [1] for the electrical specifications.

As NORA-B12 requires higher current to operate the FEM, a high-capacity battery or an external power supply should be used to power the module.

Although it is best practice to include decoupling capacitors on the supply rails close to the NORA-B1 series module, the need for additional capacitance is normally dependent on the design of the power routing in the host system.

## 1.6 System function interfaces

### 1.6.1 Module reset

NORA-B1 is reset by applying a low level on the **nRESET** input pin for a minimum of 0.2  $\mu$ sec. The pin is pulled high to VDD internally, and this low-level hold is sufficient to trigger an “external” or “hardware” reset of the module.

### 1.6.2 Internal temperature sensor

The radio chip in the NORA-B1 contains a temperature sensor that is used to monitor the temperature of the die.

 The temperature sensor is located inside the radio chip and should not be used if an accurate temperature reading of the surrounding environment is required.

## 1.7 Debug

### 1.7.1 Serial Wire Debug (SWD)

NORA-B1 series modules leverage ARM Multi-drop SWD technology for flashing and debugging. Each core shares an external connection to one set SWD signals, **SWDIO** and **SWDCLK**. The cores are then addressed individually. Additionally, NORA-B1 can be connected over the same SWD interface to other CPUs that support Multi-drop SWD.

## 1.8 GPIO pins

The code running on the application core determines the pin mapping for both application and network cores.

In an un-configured state, NORA-B1 has 48 GPIO pins and no analog or digital interfaces. All interfaces or functions must be allocated to a GPIO pin before use. Eight of the 48 GPIO pins are analog enabled, meaning that they can have an analog function allocated to them. [Table 1](#) shows the digital and analog functions that can be assigned to a GPIO pin.

Function	Description	Default NORA-B1 pin	Configurable GPIOs
General purpose input	Digital input with configurable pull-up, pull-down, edge detection and interrupt generation		Any
General purpose output	Digital output with configurable drive strength, push-pull, or open drain output		Any
Pin disabled	Pin is disconnected from the input and output buffers.	All unconfigured	Any
Timer/ counter	High precision time measurement between two pulses/ pulse counting with interrupt/event generation		Any
Interrupt/ Event trigger	Interrupt/event trigger to software application/ Wake-up event		Any
HIGH/LOW/Toggle on event	Programmable digital level triggered by internal or external events without CPU involvement		Any
ADC input	8/10/12/14-bit analog to digital converter		Any analog
Analog comparator input	Compare two voltages, capable of generating wake-up events and interrupts		Any analog
PWM output	Output simple or complex pulse width modulation waveforms		Any
Serial interfaces	For information about pin assignment restrictions, see also <a href="#">Serial interfaces</a> .		Any

**Table 1: GPIO custom functions configuration**

NORA-B12 series modules reserve P1.08 and P1.09 to control the FEM.

## 1.9 Analog interfaces

Eight of the 48 digital GPIOs can be multiplexed with the following analog functions:

- 1x 8-channel ADC
- 1x analog comparator\*
- 1x low-power analog comparator\*

\*Only one of the comparators can be used simultaneously.

### 1.9.1 ADC

The Analog-to-Digital Converter (ADC) can sample up to 200 kHz using different inputs as sample triggers. Both one-shot conversion and continuous sampling are supported. [Table 2](#) shows the sample speed in correlation to the maximum source impedance. It supports 8/10/12-bit resolution. The ADC includes 14-bit resolution if oversampling is used. Any of the eight analog inputs or **VDD** can be used either as single-ended inputs or differential pairs for measuring the voltage between them.

The ADC supports the full 0 V to **VDD** input range. If the sampled signal level is much lower than **VDD**, it is possible to lower the input range of the ADC to encompass the desired signal and obtain a higher effective resolution. Continuous sampling can be chosen for a configurable time interval, or actively triggered for different internal or external events – without any CPU involvement.

ACQ [us]	Maximum source resistance [kΩ]
3	10
5	40
10	100
15	200
20	400
40	800

**Table 2: Acquisition versus source impedance**

### 1.9.2 Comparator

The comparator compares voltages from any analog pin with different references, as shown in [Table 3](#). It supports the full 0 V to **VDD** input range and can generate different software events to the rest of the system. The comparator can operate in one of the following two modes:

- Single-ended Mode: A single reference level or an upper and lower hysteresis selectable from a 64-level reference ladder with a range from 0 V to **VREF**, as described in [Table 3](#).
- Differential Mode: Two analog pin voltage levels are compared, optionally with a ~35 mV hysteresis.

### 1.9.3 Low power comparator

The low-power comparator operates in the same way as the normal comparator, with reduced functionality. It can be used during system OFF modes as a wake-up source.

## 1.9.4 Analog pin options

Table 3 shows the supported connections of the analog functions.

An analog pin may not be simultaneously connected to multiple functions.

Symbol	Analog function	Connects to
ADCP	ADC single-ended or differential positive input	Any analog pin or VDD
ADCN	ADC differential negative input	Any analog pin or VDD
VIN+	Comparator input	Any analog pin
VREF	Comparator single-ended mode reference ladder input	Any analog pin, VDD, 1.2 V, 1.8V or 2.4V
VIN-	Comparator differential mode negative input	Any analog pin
LP_VIN+	Low-power comparator IN+	Any analog pin
LP_VIN-	Low-power comparator IN-	GPIO_16 or GPIO_18, 1/16 to 15/16 VDD in steps of 1/16 VDD

Table 3: Possible uses of the analog pin

## 1.10 Serial interfaces

### 1.10.1 Universal Asynchronous Receiver/Transmitter (UART)

NORA-B1 series modules support up to five UART ports for data communication. Four are available through the application core. One is available through the network core.

The following UART signals are available:

- Data lines (**RXD** as input, **TXD** as output)
- Hardware flow control lines (**CTS** as input, **RTS** as output)

The UART can be used as either a 4-wire UART with hardware flow control or a 2-wire UART with only **TXD** and **RXD**.

Depending on the MCUboot bootloader configuration, one of the UART interfaces on the application core can be used for software upgrades. See also [Handling and soldering](#). It is recommended that this UART is connected to a header for software upgrades or made available for test points.

The I/O level of the UART follows the VDD voltage and it can thus be in the range of 1.7 V and 3.6 V. A level shifter should be used if connecting NORA-B1 to a host with any other voltage on the UART interface.

### 1.10.2 Serial Peripheral Interface (SPI)

NORA-B1 supports up to six SPI ports that can operate with a maximum serial clock frequency of 8 MHz in either controller (master) or peripheral (slave) mode. Five are available through the application core. One is available through the network core. The SPI interfaces use the following signals:

- **SCLK**
- **MOSI**
- **MISO**
- **CS**
- **DCX** (Data/Command signal) - This signal is optional but is sometimes used by the SPI slaves to distinguish between SPI commands and data.

When using the SPI interface in controller mode, it is possible to use GPIOs as additional Chip Select (CS) signals to allow the addressing of multiple slaves.

The application core has one high-speed SPI controller (SPIM4) that can run at up to 32 Mbps. For the fastest SPI mode, the pins shown in [Table 4](#) must be used.

Signal	Pin name	Pin number	Direction	Pin drive setting	Description
SCK	P0.08	B1	O	H0H1	Serial clock, up to 32 MHz
MOSI	P0.09	C2	O	H0H1	Serial output data
MISO	P0.10	C1	I	H0H1	Serial input data
CSN	P0.11	B3	O	H0H1	Chip select, active low
DCX	P0.12	A2	O	H0H1	Data/command signal (optional)

**Table 4: High-speed SPI dedicated pin assignments (SPIM4)**

### 1.10.3 Quad Serial Peripheral Interface (QSPI)

To increase the memory size for application programs, external memory can be connected to NORA-B1 module through the Quad Serial Peripheral port.

The QSPI is available through the application core and uses dedicated pins for the interface, as shown in [Table 5](#).

Signal	Pin name	Pin number	Direction	Pin drive setting	Description
IO0	P0.13	D2	I/O	H0H1	MOSI serial output data in single mode Data I/O bit 0 in dual/quad mode
IO1	P0.14	E2	I/O	H0H1	MISO serial input data in single mode Data I/O bit 1 in dual/quad mode
IO2	P0.15	D1	I/O	H0H1	Data I/O bit 2 in quad mode
IO3	P0.16	F2	I/O	H0H1	Data I/O bit 3 in quad mode
SCK	P0.17	F1	O	H0H1	Serial clock, up to 96 MHz
CSN	P0.18	E1	O	H0H1	Chip select, active low

**Table 5: QSPI dedicated pin assignments**

### 1.10.4 Inter-Integrated Circuit (I2C) interface

NORA-B1 supports up to five I2C ports that can operate in either controller or peripheral modes. Four ports are available through the application core. One port is available through the network core.

The I2C interfaces can be used to transfer or receive data on a 2-wire bus network. NORA-B1 can operate at 100 kbps (standard), 250 kbps, and 400 kbps (fast) transmission speeds. The interface uses the **SCL** signal to clock instructions and transfers data on the **SDA** signal.

External pull-up resistors are required for the I2C interface. The value of the pull-up resistor should be selected depending on the speed and capacitance of the bus. See Electrical specifications in the NORA-B1 series data sheet [\[1\]](#) for recommended resistor values.

One of the application port I2C interfaces can be used in a high-speed mode at 1 Mbps. Dedicated pins are required for this speed.

Signal	Pin name	Pin number	Direction	Pin drive setting	Description
SCL or SDA	P1.02	B4	I/O	E0E1	Either SCL or SDA may be assigned to this pin
SCL or SDA	P1.03	A3	I/O	E0E1	Either SCL or SDA may be assigned to this pin

**Table 6: High-speed TWI dedicated pin assignments**

Set the pin drive to the S0D1 setting when assigning a I2C port to other pins.

### 1.10.5 Pulse Width Modulation (PWM) interface

NORA-B1 supports up to four PWM instances, each with four channels. All four instances are available through the application core. The PWM module enables the generation of pulse width modulated signals on GPIO. The module implements an up or up-and-down counter with four PWM channels that drive assigned GPIOs.

### 1.10.6 Inter-IC Sound (I2S) interface

NORA-B1 supports a single I2S port available on the application core. The I2S module, supports the original two-channel I2S format, and left- or right-aligned formats.

### 1.10.7 Pulse Density Modulation (PDM) interface

NORA-B1 supports a single PDM interface available through the application core. The PDM module enables input of pulse density modulated signals from external audio frontends, for example, digital microphones. The PDM module generates the PDM clock and supports single-channel or dual-channel (left and right) data input.

### 1.10.8 USB 2.0 device interface

NORA-B1 supports a single, full-speed (12 Mbps) USB device (peripheral) compliant with version 2.0 of the USB specification. The USB device port is available through the application core.

The pin configuration of the USB interface is as follows:

- **VBUS**, 5 V supply input, required to use the interface
- **USB\_DP**, **USB\_DM**, differential data pair

The USB interface has a dedicated power supply that requires a 5 V supply voltage for the **VBUS** pin. This allows the USB interface to be used even though the rest of the module might be battery powered or supplied by a 1.8 V supply.

## 1.11 Antenna interface

The antenna interface is different for each module variant in the NORA-B1 series.

### 1.11.1 U.FL connector – NORA-B100 and NORA-B120

NORA-B100 and NORA-B120 are equipped with a U.FL connector to accommodate an external antenna. The antenna must have a characteristic impedance of 50  $\Omega$  and be designed for the 2.4 GHz band. Some external antennas plug directly to the U.FL connector, while others use an SMA or reversed polarity SMA (RP-SMA) connector through a short U.FL to SMA or RP-SMA adapter cable.

Antennas equipped with an RP-SMA connector or U.FL connector are generally included in FCC, ISED, R&TTE and MIC radio tests. Antennas with SMA connectors are included in R&TTE and MIC radio tests, but due to FCC/ISED regulations are not included in FCC or ISED tests. See also the [Pre-approved antennas list](#).

NORA-B100 and NORA-B120 can be integrated with other antennas. In this instance, OEM designers must certify the both the host system and integrated antenna with the respective regulatory agencies.

### 1.11.2 Antenna pin – NORA-B101 and NORA-B121

NORA-B101 and NORA-B121 are equipped with an RF **ANT** pin. The **ANT** pin has a nominal characteristic impedance of 50  $\Omega$  and must be connected to the antenna through a 50  $\Omega$  transmission line to allow transmission and reception of radio frequency (RF) signals in the 2.4 GHz frequency band.



Choose an antenna with optimal radiating characteristics for the best electrical performance and overall module functionality. An internal antenna integrated on the application board, or an external antenna that is connected to the application board through a proper 50  $\Omega$  connector, can be used.

When using an external antenna, the PCB-to-RF-cable transition must be implemented using either a suitable 50  $\Omega$  connector, or an RF-signal solder pad (including GND) that is optimized for a 50  $\Omega$  characteristic impedance.

### 1.11.2.1 Approved antenna designs

NORA-B101 and NORA-B121 comes with a pre-certified design that can save time and reduce cost during the certification process. To leverage this benefit, customers must implement the antenna reference design layout specified in [Appendix B](#).

Designers integrating u-blox reference designs into an end-product are solely responsible for any unintentional emissions produced in the end-product.

NORA-B101 and NORA-B121 can be integrated with other antennas. In these instances, OEM designers must certify the host board design with the applicable regulatory agencies.

### 1.11.3 Integrated antenna – NORA-B106 and NORA-B126

NORA-B106 and NORA-B126 are equipped with an integrated antenna. This simplifies the integration, as there is no need to do an RF trace design on the host PCB. This also means that the pre-certification of NORA-B1, with the antenna, is even valid for the finished product design. Less time in the test lab reduces the development overhead and allows for a quicker time to market. NORA-B106 and NORA-B126 modules include PCB trace antennas with technology licensed from Proant AB.

 Modification of the PCB trace antenna is not permitted. Doing so violates world region RF certifications and declarations.

### 1.11.4 NFC antenna

NORA-B1 series modules include a Near Field Communication (NFC) interface, capable of operating as a 13.56 MHz NFC tag at a bit rate of 106 kbps. As an NFC tag, data can be read from or written to NORA-B1 modules using an NFC reader; however, NORA-B1 modules are not capable of reading other tags or initiating NFC communications. Two pins are available for connecting to an external NFC antenna: **NFC1** and **NFC2**.

## 1.12 Reserved pins (RSVD)

Do not connect reserved (**RSVD**) pins. The reserved pins are allocated for future interfaces and functionality.

## 1.13 GND pins

Good connection of the module **GND** pins, using a solid ground layer in the host application board, is necessary for correct RF performance. Proper grounding provides a thermal heat sink for the module and reduces the possibility of EMC issues.

For more information about ground plane design, see also [Module footprint and paste mask](#) and [Thermal guidelines](#).

## 1.14 FEM control (NORA-B12 only)

NORA-B12 uses an RF front end module that incorporates a power amplifier (PA) and low noise amplifier (LNA) to achieve superior RF performance. The Skyworks SKY66405-11 FEM IC used to increase TX power and RX sensitivity, providing a significantly increased link budget for long range connections. This section describes how to configure the SKY66405-11 using the GPIOs for radio operation.

The SKY66405-11 must be configured by the application firmware to allow for radio operation.

The SKY66405-11 FEM defaults to sleep mode when all nRF5340 GPIOs are left in their default state.

For the list of antennas that are approved for use with NORA-B1 modules, see also the [Pre-approved antennas list](#).

### 1.14.1 FEM Hardware

#### 1.14.1.1 FEM modes

[Table 7](#) describes the available modes of the Skyworks SKY66405-11 FEM IC.

Mode	Description
Sleep	No RF signal can be received or transmitted
Bypass	Sensitivity reduced by approximately 7 dB
Transmit	Transmit signal from nRF5340 is amplified by approximately 10 dB. The maximum transmit power allowed for the nRF5340 is +3 dBm.  The allowed power settings depend on the region, modulation mode, and channel.
Receive	For most conditions, receive sensitivity is improved by 5 db compared to NORA-B10

**Table 7: Skyworks SKY66405-11 FEM modes**

#### 1.14.1.2 FEM control pins

[Table 8](#) shows the control signal names, pin names, and the state in which the pins must be for each mode. The switching time between states is < 1  $\mu$ S.

State	TX_EN (P1.08)	RX_EN (P1.09)
Sleep	Low	Low
Transmit (PA enabled)	High	Low
Receive (LNA enabled)	Low	High
Bypass	High	High

**Table 8: FEM control logic**

### 1.14.1.3 FEM Power limitations

Table 9 describes the maximum allowable power setting values that can be used in the NRF\_RADIO -> TXPOWER register of the nRF5340. The maximum setting must be observed to comply with the regulatory power output and band-edge requirements.

Agency	World region	Maximum nRF5340 transmit power setting TXPOWER register	SKY66405-11 mode during transmit	Limitations
FCC	USA	+3 dBm (0x00000000) VREGRADIO.VREQH = 1	PA transmit enabled	Any approved antenna
ISED	Canada	+3 dBm (0x00000000) VREGRADIO.VREQH = 1	PA transmit enabled	Any approved antenna
CE-RED	Europe	TBD	PA transmit enabled	

**Table 9: Regulatory transmit power limits**



u-blox recommends that you confirm the transmit power limits for the different world regions with an accredited certification agency.

### 1.14.2 FEM enablement

NCS directly supports FEM control through the Bluetooth LE SoftDevice controller subsystem. Only the board support package for the hardware requires modified modification. To enable the FEM on NORA-B12, insert following lines into the <boardname>\_cpunet\_defconfig file:

```
# PA GPIO Pin (NORA-B12 pin P1.08)
CONFIG_BT_CTLR_GPIO_PA=y
CONFIG_BT_CTLR_GPIO_PA_PIN=40

# LNA GPIO Pin (NORA-B12 pin P1.09)
CONFIG_BT_CTLR_GPIO_LNA=y
CONFIG_BT_CTLR_GPIO_LNA_PIN=41
```

The hci\_rpmsg example uses the SoftDevice controller and references the cpunet core board support files when compiled and loaded onto the network core. With this modification to hci\_rpmsg hex file, Bluetooth LE sample code in .\ncs\vX.Y.Z\zephyr\samples\bluetooth and .\ncs\v1.6.1\nrf\samples\bluetooth may be run on the application core without modification.

GPIOs are assigned by the code running on the application core. See also [Applications](#).

## 2 Custom hardware support

A board support package (BSP) is required to define the target hardware when compiling Zephyr applications within NCS.

### 2.1 Available EVK BSPs

Table 10 shows the available NORA-B1 BSPs.

Module	Zephyr board	Supported board	On-board debug probe
NORA-B10	ubx_evknorab10_nrf5340	EVK-NORA-B100, EVK-NORA-B106	Yes
	ubx_mininorab10_nrf5340	MINI-NORA-B100, MINI-NORA-B106	No
NORA-B12 <sup>1</sup>	ubx_evknorab12_nrf5340	EVK-NORA-B120, EVK-NORA-B126	Yes
	ubx_mininorab12_nrf5340	MINI-NORA-B120, MINI-NORA-B126	No

Table 10: Available NORA-B1 EVKs

The EVK BSP files can be used as a starting point for creating a unique BSP for custom end-product hardware.

These BSP files will be submitted for inclusion in mainline Zephyr. Until they are merged, the BSP files may be found at the u-blox GitHub repository [5].

Support for custom hardware can be added through adding a subdirectory in the `.\ncs\vX.Y.Z\zephyr\boards\arm` directory, where X.Y.Z is the installed NCS version. It is usually best to copy the board support package (BSP) of one of the EVKs and make the necessary edits to suit the custom hardware in the new folder.

### 2.2 BSP files

Figure 6 shows the contents of the EVK-NORA-B1 ESP.

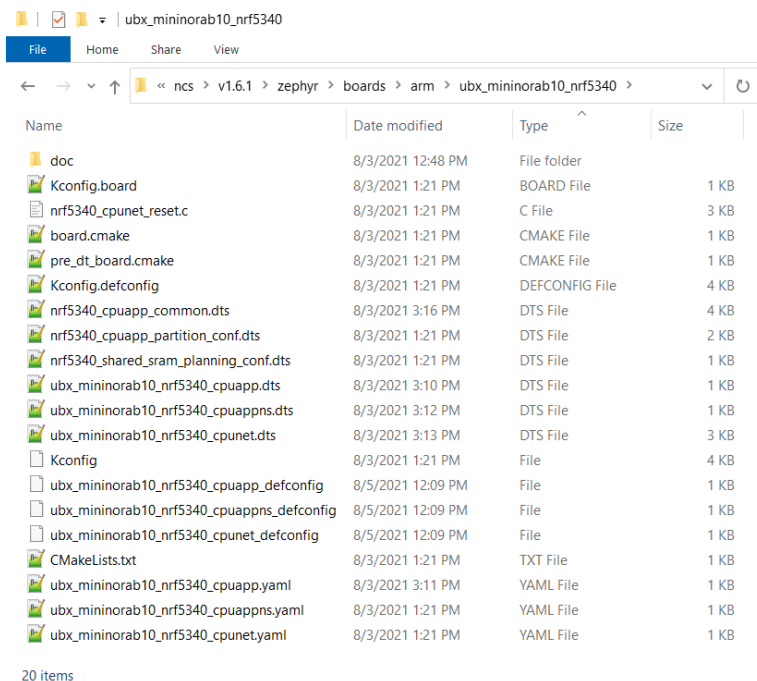

Figure 6: EVK-NORA-B1 BSP folder contents

<sup>1</sup> Pending release. Not currently available.

## 2.2.1 board.cmake

`board.cmake` instructs the Zephyr west (the `SDK/Zephyr` build system) which debugger and programmer to use when interacting with the hardware over the SWD port. This file is not normally edited.

## 2.2.2 CMake

`CMakeLists.txt` directs Zephyr west to the source files. In some application structures, this file may need to be edited. If the BSP for the custom hardware has been copied from an existing application, this file is not normally edited. An optional `cmake` file can be included for unique hardware.

## 2.2.3 Kconfig

The Zephyr kernel and subsystems are configured at build time for specific application and platform requirements. The three `Kconfig` files are:

- `Kconfig`: Selects nRF5340 options, such as enabling both application and network coprocessors, DC-DC converter, encryption block (ECC), and sets memory sizes among other options.
- `Kconfig.board`: Defines the board names and filename patterns.
- `Kconfig.defconfig`: Defines dependencies between different options and default configurations.

## 2.2.4 Device tree

The device tree files (DTS) assign actual hardware attributes (pins) to device drivers (nodes). For NORA, a minimum of three files are required – one for the application core, one for the non-secure portion of the application core, and one for the network core. There may be additional files to define flash and RAM partitions. With the EVK-NORA-B1 BSP, a common DTS file is also used to prevent the need to maintain redundant information.

## 2.2.5 YAML

The YAML files define which device driver nodes are supported by the board. The DTS files then refer to these nodes. As with DTS, separate files are required for the different cores.

## 2.2.6 Defconfig

The `<boardname>_defconfig` files do not use a filename extension. These files enable additional features, typically pre-compiler directives. As with DTS, separate files are required for each core. For NORA-B12 FEM support, see also [FEM enablement](#).

## 2.2.7 Helper code

Additional files, typically C source code, can be included to configure the hardware during system initialization, configure reset schemes, and other unique code that is not included with the SDK.

## 2.2.8 Documentation

The `doc` folder contains a ReStructured Text (RST) file which contains documentation about the board that describes the pin-out, images, and other information. This folder is optional for BSP files that are not submitted as part of the mainline Zephyr project.

## 3 Software development

NORA-B1 series modules are used as open CPU modules in which applications developed with the Nordic Semiconductor nRF Connect SDK can be run. The most recent application development guidelines are found at the nRF Connect SDK documentation for application development [20] and working with the nRF53 [21]. These following sections in this chapter provide details about Zephyr, MCUboot, and the nRF53 in NORA-B1.

### 3.1 Nordic Semiconductor nRF Connect SDK

With a broad selection of drivers and libraries, the Nordic Semiconductor nRF Connect SDK provides a rich development environment for various devices and applications. The software development kit (SDK) is delivered through the nRF Connect for Desktop application provided by Nordic Semiconductor.

nRF Connect SDK includes the Zephyr Project RTOS, MCUboot secure bootloader, nrfxdrv libraries for the peripherals provided within the nRF5340 chip, and extensions for Microsoft Visual Studio. The SDK can be downloaded from the Nordic Semiconductor website [17]. Visual Studio can be downloaded from the Microsoft website [28].

After installing the main program, select the following software modules for installation:

- Bluetooth Low Energy – general tool for development and testing with Bluetooth Low Energy
- Toolchain Manager – install and manage tools to develop with the nRF Connect SDK

Other software modules in nRF Connect for Desktop can be useful but are not required for application development.

#### 3.1.1 Toolchain Manager

Application development is done using the suite of tools installed by the Toolchain Manager.

1. Open the Toolchain Manager. Several versions of the nRF Connect SDK are offered. If this is a new install, select the latest one for installation.
2. Select an installation folder. If the default is not used, ensure that no spaces are included in the given folder path.
3. The installation can take several minutes to download and several more to install SES, git tools, bash shell, a fork of the Zephyr RTOS source code, Nordic's custom source code (nrfxdrv), and MCUboot. While waiting, check the information using the "First steps to build" button. The displayed information is customized to the installation folder chosen above. If the EVK-NORA-B1 development board is used for development, the examples given for the nRF5340 DK (pca\_10095) can be used without modification.
4. Once the install is complete, open the IDE.
5. From this point, follow the "First steps to build" instructions presented by the Toolchain Manager and nRF Connect SDK online documentation.

Nordic Semiconductor provides a free, unlimited, commercial license for SES.

#### 3.1.2 Documentation – nRF Connect SDK

Full documentation for the nRF Connect SDK is continually updated on the dedicated nRF Connect SDK documentation website [19].

### 3.1.3 Support – Nordic Semiconductor DevZone development forum

For support with questions about the development of software using the nRF Connect SDK, refer to the Nordic Semiconductor DevZone support site [22]. Public discussions and private tickets are available on the site, where the Nordic engineers and forum members respond to all contributions.

## 3.2 Bluetooth device (MAC) address and other production data

NORA-B1 modules are programmed from the factory with a unique, public Bluetooth device address stored in the OTP[0] and OTP[1] registers of the User Information Configuration Registers (UICR) in the application core. The device addresses are duplicated in the CUSTOMER[0] and CUSTOMER[1] registers in the UICR of the network core.

The Bluetooth device address consists of the IEEE Organizationally Unique Identifier (OUI) combined with the hexadecimal digits that are printed within a 2D data matrix, as described in the Labeling and ordering section of the product data sheet [1].

The Bluetooth device address is stored in little-endian format. The two most significant bytes of the OTP[1] and CUSTOMER[1] registers are unused and assigned the value 0xFF to complete the 32-bit register.

UICR register in application core	Address	Description	Remarks
OTP[0]	0x00FF8100	0xAA = Bluetooth_addr [5]	IEEE OUI <sup>2</sup>
OTP[0]	0x00FF8101	0xBB = Bluetooth_addr [4]	IEEE OUI <sup>2</sup>
OTP[0]	0x00FF8102	0xCC = Bluetooth_addr [3]	IEEE OUI <sup>2</sup>
OTP[0]	0x00FF8103	0xDD = Bluetooth_addr [2]	Example – actual value printed on label
OTP[1]	0x00FF8104	0xEE = Bluetooth_addr [1]	Example – actual value printed on label
OTP[1]	0x00FF8105	0xFF = Bluetooth_addr [0]	Example – actual value printed on label
OTP[1]	0x00FF8106	0xFF	Unused
OTP[1]	0x00FF8107	0xFF	Unused

**Table 11: Bluetooth device address in application core**

UICR register in network core	Address	Description	Remarks
CUSTOMER[0]	0x01FF8300	0xAA = Bluetooth_addr [5]	IEEE OUI <sup>2</sup>
CUSTOMER[0]	0x01FF8301	0xBB = Bluetooth_addr [4]	IEEE OUI <sup>2</sup>
CUSTOMER[0]	0x01FF8302	0xCC = Bluetooth_addr [3]	IEEE OUI <sup>2</sup>
CUSTOMER[0]	0x01FF8303	0xDD = Bluetooth_addr [2]	Example – actual value printed on label
CUSTOMER[1]	0x01FF8304	0xEE = Bluetooth_addr [1]	Example – actual value printed on label
CUSTOMER[1]	0x01FF8305	0xFF = Bluetooth_addr [0]	Example – actual value printed on label
CUSTOMER[1]	0x01FF8306	0xFF	Unused
CUSTOMER[1]	0x01FF8307	0xFF	Unused

**Table 12: Bluetooth device address in network core**

NORA-B1 modules are provided from the factory with access port protection and erase protection disabled. This allows reading of the address through the Nordic Semiconductor Command Line Tools and J-Link utilities. See also references [23] and [24].

Use the versions of the Nordic Semiconductor Command Line Tools supplied with NCS. These can be accessed by opening a bash or command prompt window through the NCS Toolchain Manager, as shown in Figure 7. This configures the session with the necessary environment variables.

<sup>2</sup> Example value shown. The full Bluetooth device address is encoded in the label data matrix and stored in the UICR for each core.

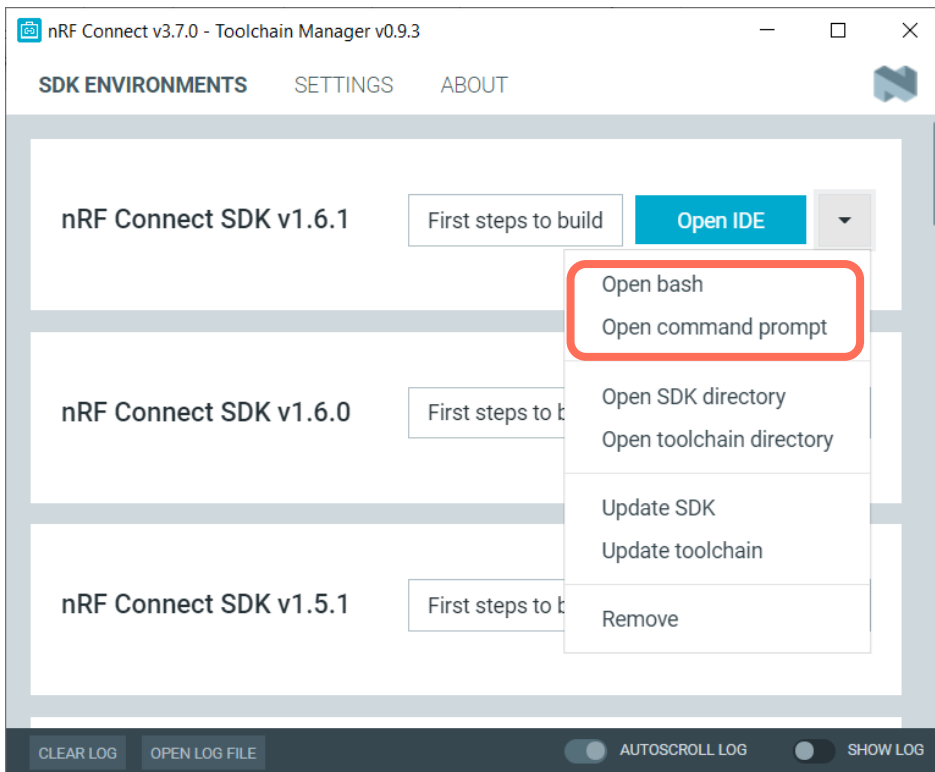

**Figure 7: NCS command line selections**

Read the Bluetooth device address from both cores with `nrfjprog` using the example values in [Table 11](#) and [Table 12](#).

```
C:\ubx>nrfjprog -f nrf53 -memrd 0x00ff8100 -n 8
0x00FF8100: DCCBBAA FFFFFFFE |.....|

c:\ubx>nrfjprog -f nrf- --coprocessor CP_NETWO- --memrd 0x01ff83- --n 8
0x01FF8300: DCCBBAA FFFFFFFE |.....|
```

The Bluetooth device address can also be saved to a binary file using the `savebin` command in the SEGGER J-link tool suite:

```
J-Link>savebin bdaddr.bin, 0x00ff8100, 8
```

When using J-Link, the cores are identified as `NRF5340_XXAA_APP` and `NRF5340_XXAA_NET` when establishing the connection to the application and network cores.

Having a copy of the Bluetooth device address stored in a file is useful when reprogramming each core after a chip erase or recovery.

The entire UICR memory area can hold other valuable information. Use the following command to save the entire UCIR memory area:

```
nrfjprog.e- --readuicr uicr.hex
```

The Bluetooth device address can only be written to the UICR of each core after a recovery or full chip erase. See also [Flashing application software](#) for recovery and erasing details. If an electronic copy of the address is not saved, the address may be recovered by scanning the 2D data matrix on the NORA-B1 label. See also the NORA-B1 data sheet [\[1\]](#).

Writing the Bluetooth device address may be done through the following `nrfjprog` commands following a chip erase or recovery.



```
c:\ubx>nrfjprog -f nrf- --memwr 0x00ff81- --val 0xddccbbaa
c:\ubx>nrfjprog -f nrf- --memwr 0x00ff81- --val 0xffffffffee

c:\ubx>nrfjprog -f nrf- --coprocessor CP_NETWO- --memrd 0x01ff83- --val 0xddccbbaa
c:\ubx>nrfjprog -f nrf- --coprocessor CP_NETWO- --memrd 0x01ff83- --val 0xffffffffee
```

J-Link may also be used. For the application core:

```
J-Link>loadbin bdaddr.bin, 0x00ff8100
```

For the network core:

```
J-Link>loadbin bdaddr.bin, 0x01ff8300
```

The Bluetooth device address is provided in both cores for convenience. If only one core accesses the address, the other core does not need to be rewritten.

Example programs provided with NCS do not use the programmed public Bluetooth device address. A static random address is used which is derived from the FICR registers. An application must read the public address and set the address with `bt_ctlr_set_public_addr()` in Zephyr or `sdhci_cmd_vs_zephyr_write_bd_addr()` in nrfxlib.

## 4 Applications

### 4.1 Application and network core projects

When developing for NORA-B1, at least two projects are required, one for each core. For most Bluetooth LE applications, the HCI interface resides on the network core where it operates the radio. The application running on the application core then performs most other functions and communicates with the network core through remote procedure messaging. When working with secured code, an additional project is required for non-secure code. See also reference [21].

The application core must be used to configure the GPIO for both cores. Even if all functions operate on the network core, the application core must still be loaded with a minimal application (e.g., a simple `while(1); loop`).

### 4.2 Project folder

The `west build` of NCS is configured in such a way that an application project can be separated from the SDK itself. The development system environment variables contain the path information to the different SDK components. This allows developers to maintain clean, independent application folders for version control purposes.

The file structure of a minimal project looks like this:

```
<home>/app
|
+--- CMakeLists.txt
|
+--- prj.conf
|
+--- board.overlay (optional)
|
+--- src
    |
    +--- main.c
```

Project files for each core, and non-secure domain if used, are placed in separate folders. If an end-product incorporates both secure and non-secure code execution, a third project folder for the non-secure portion is also required. See also reference [21].

#### 4.2.1 CMakeLists.txt

As with the BSP, `CMakeLists.txt` instructs `west` where to find the source code, the Zephyr system, project name, and other application specific options.

#### 4.2.2 prj.conf

`prj.conf` is a `_defconfig` overlay file. This is used to override Zephyr features that may be configured otherwise in the board `_defconfig` file. This allows the resulting code to only contain the necessary features of the application, which reduces the required memory.

#### 4.2.3 board.overlay

`board.overlay` is an optional file. As with `prj.conf`, it is used to enable and disable drivers at a hardware level. For example, if a certain environmental sensor were connected to NORA-B1 over the I2C bus, this file would provide additional information required by the sensor's device driver, like the I2C address and signal assignments, for the module to communicate with sensor over the I2C bus.

#### 4.2.4 Source code

The `src` folder contains any source code files for the application. It is not necessary to include a `main.c` file if the Zephyr system initialization feature (`SYS_INIT`) is used. Initialization code can be called by `SYS_INIT`, allowing for an orderly system start-up. If a `main()` function is present, Zephyr uses that as an entry point for the application once `SYS_INIT` is complete.

### 4.3 Example code

NCS provides many samples (examples) to exercise all features of the NORA-B1 modules. Samples that are provided by mainline Zephyr are located in `.\ncs\vX.Y.X\zephyr\samples`. Samples provided from Nordic Semiconductor are located in `.\ncs\vX.Y.Z\nrf\samples`.

For information about installing and using the development tools, see also the EVK-NORA-B1 user guide [\[3\]](#) and MINI-NORA-B1 user guide [\[4\]](#).

NORA-B1 modules are loaded with a simple application to enable the debug interface in both the application and network cores. EVK-NORA-B1 and MINI-NORA-B1 EVKs are loaded with the `peripheral_lbs` sample on the application core and `hci_rpmsg` sample on the network core.

## 5 Flashing application software

Both the application and network cores of the NORA-B1 modules are flashed over a common SWD interface. See also reference [21].

### 5.1 SWD interface

A SEGGER J-Link debug interface is required to program the NORA-B1 module flash over the SWD port.

EVK-NORA-B1 evaluation kits include a J-LINK-OB that is used to program and debug the on-board NORA-B1 as well as the target hardware for ANNA-B1, BMD-3, NINA-B1, NINA-B3, NINA-B4, and NORA-B1 modules.

 The debug out connector on BMD-3xx-EVAL EVK boards cannot be used to debug and program NORA-B1.

### 5.2 Readback protection

By default, readback protection is enabled in NORA-B1. To use the SWD interface, the `UICR.APPROTECT` register must be set to “unprotected”. In addition, the code running on the core must set the `CTRL-AP.APPROTECT.DISABLE` register to the same value. Each core is separately protected. The application core also contains `UICR.SECUREAPPROTECT` and `CTRL-AP.SECUREAPPROTECT.DISABLE` registers which may be enabled separately to block all secure access through the application core. See also reference [17].

NORA-B1 is provided from the factory with readback protection fully disabled.

 Open CPU application firmware and the UICR must include these settings to debug or reprogram NORA-B1. If these settings are not provided, each core needs to be recovered to enable the SWD port.

### 5.3 Recovery

If SWD access becomes disabled, NORA-B1 must be recovered. `west` can perform a full recovery of both cores with a single command:

```
west --recover
```

If `nrfjprog` is used, each core of NORA-B1 must be recovered separately. This process fully erases both the flash and UICR:

```
nrfjprog -f nrf53 --coprocessor CP_NETWORK --recover
nrfjprog -f nrf53 --recover
```

 When the network core is recovered, it erases both the network and application cores. When the application core is recovered, only the application core is affected. For this reason, it is important to first recover the network core so the readback protection can be properly disabled.

The Bluetooth device address is erased using this process. For information about restoring the address to the UICR, see also Bluetooth device (MAC) address and other production data.

## 5.4 Programming

SES can be used to interactively erase, program, and debug application core and network core code.

At the command line, the `west` tool provided by the nRF Connect SDK provides a simple method of programming both cores of the NORA-B1 module in one step. After building the project, open a command prompt or terminal window, navigate to the build folder, and enter:

```
west flash
```

An alternate method is to use the nRF Command Line Tools [\[23\]](#). Open a command prompt and execute the following commands to erase the NORA-B1:

```
nrfjprog -f NRF53 --coprocessor CP_NETWORK --eraseall
nrfjprog -f NRF53 --eraseall
```

Navigate to the build folder of the network sample and execute the following command to program the network core:

```
nrfjprog -f NRF53 --coprocessor CP_NETWORK --program zephyr/zephyr.hex --chiperase
```

Then navigate to the build folder of the application sample and enter the following command to program the application core:

```
nrfjprog -f NRF53 --program zephyr/zephyr.hex --chiperase
```

Finally, reset the NORA-B1 module with:

```
nrfjprog --pinreset
```

External SEGGER J-Link debuggers work with NORA-B1 modules.

The EVK-NORA-B1 evaluation kit incorporates an onboard debugger and can therefore be flashed without any external debugger.

The EVK-NORA-B1 evaluation kit onboard debugger can also be used to program custom hardware with Nordic Semiconductor-based u-blox modules during development. The debugger is not intended for use in production environments.

## 6 Design-in

### 6.1 Overview

For optimal integration of NORA-B1 in the final application board, the design guidelines described in this chapter are recommended. Every application circuit must be properly designed to ensure that the related interface functions correctly, but the following topics require special attention during the design of the application device.

1. Module antenna connection: **ANT** pad – NORA-B101 and NORA-B121 only.  
The antenna circuit affects the RF compliance of devices integrating NORA-B101 or NORA-B121 with the applicable certification schemes. Follow the design layout recommendations provided in [Antenna interface](#).
2. Module supply: **VDDH**, **VDD**, and **GND** pins.  
The supply circuit affects the performance of devices integrating NORA-B1 series modules. Follow the PCB design layout recommendations for [Supply interfaces](#).
3. Analog signals: **GPIO**.  
Analog signals are sensitive to noise and should be routed away from high frequency signals.
4. High speed interfaces: **I2C**, **I2S**, **SPI**, **QSPI**, **UART** and **USB** pins.  
High speed interfaces can be a source of radiated noise that can affect compliance with regulatory standards for radiated emissions. Follow the schematic and [General high-speed layout guidelines](#).
5. System functions: **nRESET**, **SWD**, **GPIO** and other system input and output pins.  
Accurate design is required to ensure that the voltage level is well defined during module boot.
6. Other pins: unused GPIO pins should be left open.

### 6.2 Design for NORA family

NORA-B1 is based on the Nordic Semiconductor nRF5340 Bluetooth LE System-on-Chip (SoC). The 10.4 mm x 14.3 mm footprint is common to all NORA-B1 series modules. Future module variants may contain a subset of the NORA footprint to accommodate space-constrained designs.

### 6.3 Antenna interface

To optimize the radiated performance of the final product, the selection and placement of both the module and antenna must be chosen with due regard to the mechanical structure and electrical design of the end-product. To avoid later redesigns, it is important to decide the positioning of these components at an early phase of the end-product design. Carefully consider the placement of the embedded antenna in NORA-B106 and NORA-B126, or an external antenna (connected through SMD assembly or RF connector) in NORA-B100, NORA-B101, NORA-B120, and NORA-B121.

Choose a module variant that supports an external antenna if the product includes a metal product enclosure.

- **NORA-B100** and **NORA-B120** modules include a U.FL connector for connecting an external antenna. Some antennas connect **directly** to the U.FL, while others connect through a short U.FL or reversed polarity SMA adapter cable (100 mm minimum).
  - Antennas with SMD connections, either reverse-polarity SMA connectors or U.FL connectors, must be radio tested and verified against regulatory FCC, IC, RED, and MIC standards.
- **NORA-B101** and **NORA-B121** modules include an ANT pad for connecting an external antenna. The antenna can be either an external SMD antenna or an antenna that is connected through an externally assembled U.FL or RP-SMA connector.
  - Antennas with SMD connections, either reverse-polarity SMA connectors or U.FL connectors, must be radio tested and verified against regulatory FCC, IC, RED, and MIC standards.

- **NORA-B106** and **NORA-B126** modules include an embedded PCB antenna. See also [On-board antenna \(NORA-B106 and NORA-B126 only\)](#) for design-in information. **NORA-B106** and **NORA-B126** cannot be mounted inside a metal enclosure. Similarly, the physical casing accommodating these modules must not be fabricated in metal or any plastic that includes metal flakes, metallic based paint, carbon black, or lacquer.

**⚠** According to FCC regulations, the transmission line from the module antenna pin to the antenna (or antenna connector) on the host PCB is considered part of the approved antenna design. Consequently, module integrators must follow exactly one of the antenna reference designs used in the module during FCC type approval – or certify their own designs.

### 6.3.1 RF transmission line design (NORA-B101 and NORA-B121 only)

RF transmission lines like those from the **ANT** pad up to the related antenna connector, or up to the related internal antenna pad, must be designed so that the characteristic impedance is as close as possible to  $50\ \Omega$ . Tolerances of  $\pm 5\ \Omega$  are commonly specified. [Figure 8](#) shows the design options and the parameters that must be considered when implementing a transmission line on a PCB, where:

- **Microstrip** is a track coupled to a single ground plane, separated by dielectric material.
- **Coplanar microstrip** (also known as **Coplanar waveguide**) is a track coupled to ground plane and side conductors, separated by dielectric materials.
- **Stripline** is a track sandwiched between two parallel ground planes and separated by dielectric materials.

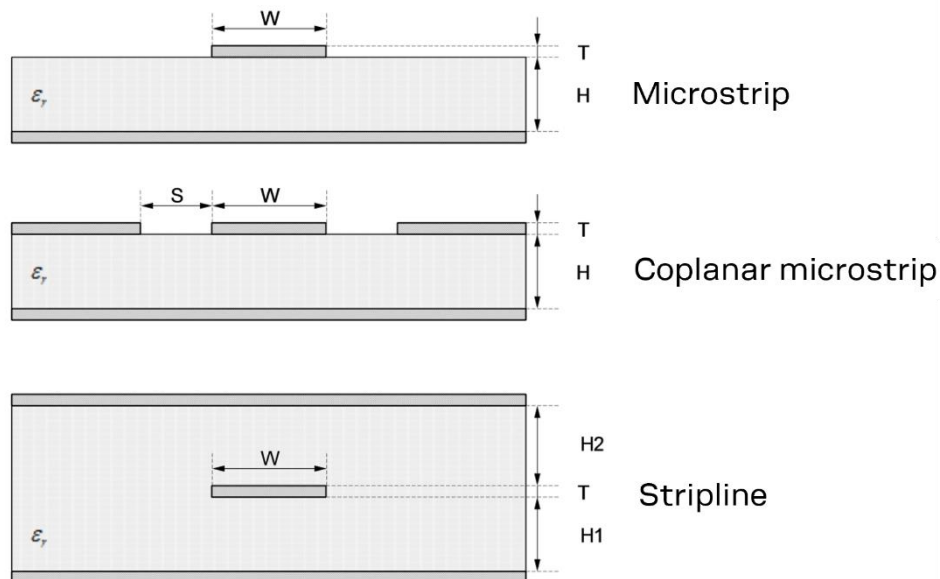

**Figure 8: Transmission line trace design**

To design a  $50\ \Omega$  transmission line properly, consider the following points:

- Designers should provide enough clearance from the surrounding traces and ground plane in the same layer. Consider a trace-to-ground clearance that is at least twice the width of the trace, and make sure that the transmission line is “guarded” by the ground plane area on each side.
- The characteristic impedance can be calculated as a first iteration by using tools provided by the layout software. It is advisable to ask the PCB manufacturer for the final values that are usually calculated using dedicated software and the available stack-ups from production. To measure the real impedance of the traces, you might also ask the manufacturer to attach an impedance coupon to the side of the panel.

- Despite the high losses anticipated at high frequencies, FR-4 dielectric materials can be considered in RF designs, providing that:
  - RF trace lengths are minimized to reduce dielectric losses.
  - If traces longer than a few centimeters are needed, the use of coaxial connectors and cables are advised to reduce anticipated losses.
  - Stack-up should allow for thick 50  $\Omega$  traces. A trace width of at least 200  $\mu\text{m}$  is recommended to ensure good impedance control during the PCB manufacturing process.
  - FR-4 material exhibits poor thickness stability and poorer control of impedance over the trace length. Contact the PCB manufacturer to find out about the specific tolerances of controlled impedance traces.
- The width and spacing of transmission lines to GND must be uniform and routed as smoothly as possible: route RF lines at 45° angles or in arcs.
- Add GND stitching vias around transmission lines.
- Ensure solid metal connection of the adjacent metal layer on the PCB stack-up to the main ground layer, providing enough vias on the adjacent metal layer.
- Route RF transmission lines far from any noise source (such as switching supplies and digital lines) and from any sensitive circuit to avoid crosstalk between RF traces and high impedance or analog signals.
- Avoid stubs on the transmission lines; any component on the transmission line should be placed with the connected pad over the trace. Also avoid any unnecessary components on RF traces.

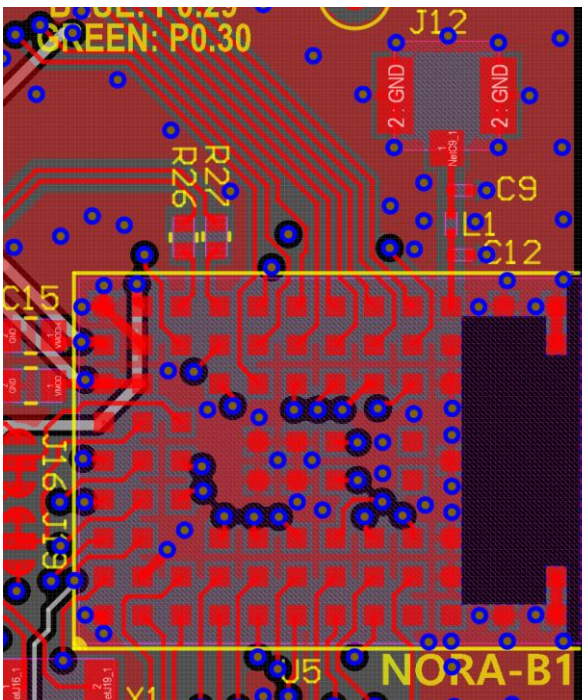

Figure 9: Example of RF trace and ground plane design

### 6.3.2 Antenna design (NORA-B101 and NORA-B121 only)

NORA-B101 and NORA-B121 are suitable for designs where an external antenna is needed due to mechanical integration or placement of the module, or where a host PCB trace or SMT antenna is required by the application.

Designers must consider the physical dimensions of the application board at the beginning of the design phase of the end-product. This is important because the RF compliance of the device integrating the NORA-B1 module, together with all the required certification schemes, heavily depends on the radiating performance of the antennas.



Designers are encouraged to consider one of the u-blox suggested antenna part numbers and follow the layout requirements.

- External antennas, such as a linear monopole:
  - External antennas do not impose any physical restrictions on the design of the PCB where the module is mounted.
  - The radiation performance mainly depends on the antennas. It is necessary to select antennas with optimal radiating performance in the operating bands.
  - RF cables that offer minimum insertion loss should be carefully chosen. Unnecessary insertion losses are introduced by low quality or long cables. Large insertion loss reduces the radiation performance.
  - A high quality 50 Ω coaxial connector provides proper PCB-to-RF-cable transition.
- Integrated antennas such as patch-like antennas:
  - Internal integrated antennas impose physical restrictions on the PCB design:

An integrated antenna excites RF currents on its counterpoise, typically in the PCB ground plane of the device that effectively becomes part of the antenna. Consequently, the dimensions of the ground plane define the minimum frequency that can be radiated. To optimize radiation, the ground plane can be reduced to a minimum size that should not be less than a quarter of the wavelength frequency that needs to be radiated. The orientation of the ground plane in relation to the antenna element must be considered.

The RF isolation between antennas in the system must be as high as possible and the correlation between the 3D radiation patterns of the two antennas must be as low as possible. An RF separation of at least a quarter wavelength between the two antennas is generally required to achieve a maximum isolation and low pattern correlation; consider increasing separation, if possible, to maximize performance and fulfill the requirements in [Table 13](#).

As a numerical example, consider the following physical restrictions of the PCB:

$$\text{Frequency} = 2.4 \text{ GHz} \rightarrow \text{Wavelength} = 12.5 \text{ cm} \rightarrow \text{Quarter wavelength} = 3.125 \text{ cm}^3$$

- Radiation performance depends on the antenna system design, the mechanical design of the final product, and the application use case. Antennas should be selected with optimal radiating performance in the operating bands according to the mechanical specifications of the PCB and the entire product.

[Table 13](#) summarizes the requirements for the antenna RF interface.

Item	Requirements	Remarks
<b>Impedance</b>	50 Ω nominal characteristic impedance	The impedance of the antenna RF connection must match the 50 Ω impedance of the <b>ANT</b> pin.
<b>Frequency Range</b>	2400 - 2500 MHz	Bluetooth low energy.
<b>Return Loss</b>	$S_{11} < -10 \text{ dB}$ (VSWR < 2:1) recommended $S_{11} < -6 \text{ dB}$ (VSWR < 3:1) acceptable	The Return loss or the $S_{11}$ , as the VSWR, refers to the amount of reflected power, measuring how well the primary antenna RF connection matches the 50 Ω characteristic impedance of the <b>ANT</b> pin.  The impedance of the antenna termination must match as much as possible the 50 Ω nominal impedance of the <b>ANT</b> pin over the operating frequency range, thus maximizing the amount of the power transferred to the antenna.
<b>Efficiency</b>	$> -1.5 \text{ dB}$ (> 70%) recommended $> -3.0 \text{ dB}$ (> 50%) acceptable	The radiation efficiency is the ratio of the radiated power to the power delivered to the antenna input; the efficiency is a measure of how well an antenna receives or transmits.

<sup>3</sup> Wavelength referred to a signal propagating over the air

Item	Requirements	Remarks
Maximum Gain	+5.3 dBi (NORA-B100, NORA-B101) +3.2 dBi (NORA-B120, NORA-B121)	Higher gain antennas could be used but must be evaluated and/or certified. See also <a href="#">Regulatory information and requirements</a> .

**Table 13: Summary of antenna interface (ANT) requirements for NORA-B1**

Observe the following recommendations when selecting external or internal antennas:

- Choose antennas with an optimal return loss (or VSWR) figure across all operating frequencies.
- Choose antennas that provide optimal efficiency figures across all operating frequencies.
- Choose antennas that provide an appropriate gain figure; that is, combined antenna directivity and efficiency figures that ensure that the electromagnetic field radiation intensity does not exceed the regulatory limits specified in some countries. For example, the regulatory limits set by the FCC in the United States.

### 6.3.2.1 RF connector design

If an external antenna is required, the designer should consider using a proper RF connector. It is the responsibility of the designer to verify the compatibility between plugs and receptacles used in the design.

[Table 14](#) suggests some RF connector plugs that can be used by the designers to connect RF coaxial cables based on the declaration of the respective manufacturers. The Hirose U.FL-R-SMT RF receptacles (or similar parts) require a suitable mated RF plug from the same connector series. Due to wide usage of this connector, several manufacturers offer compatible equivalents.

Manufacturer	Series	Remarks
Hirose	U.FL® Ultra Small Surface Mount Coaxial Connector	Recommended
I-PEX	MHF® Micro Coaxial Connector	
Tyco	UMCC® Ultra-Miniature Coax Connector	
Amphenol RF	AMC® Amphenol Micro Coaxial	
Lighthouse Technologies, Inc.	IPX ultra micro-miniature RF connector	

**Table 14: U.FL compatible plug connector**

Typically, the RF plug is available as a cable assembly. Different types of cable assemblies are available; the user should select the cable assembly best suited to the application. The key characteristics are:

- RF plug type: select U.FL or equivalent
- Nominal impedance: 50  $\Omega$
- Cable thickness: Typically, from 0.8 mm to 1.37 mm. Select thicker cables to minimize insertion loss.
- Cable length: Standard length is typically 100 mm or 200 mm. Select shorter cables to minimize insertion loss.
- RF connector on the other side of the cable: For example, another U.FL (for board-to-board connection) or SMA (for panel mounting).

Consider that SMT connectors are typically rated for a limited number of insertion cycles. In addition, the RF coaxial cable may be relatively fragile compared to other types of cables. To increase application ruggedness, connect the U.FL connector to a more robust connector such as SMA fixed on panel.

A de-facto standard for SMA connectors implies the usage of reverse polarity connectors (RP-SMA) on Wi-Fi and Bluetooth end-products. The standard makes it more difficult for the end users to replace the antenna with higher gain versions and exceed the regulatory limits.

Observe these recommendations for proper layout of the connector:

- Strictly follow the connector manufacturer's recommended layout:
  - SMA Pin-Through-Hole connectors require GND keep-out (that is, clearance, a void area) on all the layers around the central pin up to annular pads of the four GND posts.
  - U.FL surface mounted connectors require no conductive traces (that is, clearance, a void area) in the area below the connector between the GND land pads.
- If the RF pad size of the connector is wider than the micro strip, remove the GND layer beneath the RF connector to minimize the stray capacitance thus keeping the RF line 50  $\Omega$ . For example, the active pad of the U.FL connector must have a GND keep-out (that is, clearance, a void area), at least on the first inner layer to reduce parasitic capacitance to ground.

### 6.3.2.2 Integrated antenna design

The following guidelines should be followed when integrating an antenna onto the host PCB:

- Antenna integration should begin at the start of the end-product design process. Self-made PCBs and antenna assemblies are useful in estimating overall efficiency and the radiation path of the intended design.
- Use antennas designed by an antenna manufacturer providing the best possible return loss (or VSWR).
- Provide a ground plane that is large enough to meet the related integrated antenna requirements. The ground plane of the application PCB can be reduced to a minimum size of one-quarter wavelength of the minimum frequency that needs to be radiated, although overall antenna efficiency may benefit from larger ground planes.
- Proper placement of the antenna and its surroundings is also critical for antenna performance. Avoid placing the antenna close to conductive or RF-absorbing parts such as metal objects, ferrite sheets and so on as they may absorb part of the radiated power or shift the resonant frequency of the antenna or affect the antenna radiation pattern.
- It is highly recommended to strictly follow the detailed and specific guidelines provided by the antenna manufacturer regarding correct installation and deployment of the antenna system, including the PCB layout and matching circuitry.
- In addition to the custom PCB and product restrictions, antennas may require tuning/matching to comply with all the applicable required certification schemes. It is advisable to consult the design-in guidelines of the antenna manufacturer and plan the validation activities on the final prototypes, like tuning/matching and taking performance measurements. See also [Table 13](#).
- The RF section may be affected by noise sources like high-speed digital buses. Avoid placing the antenna close to buses such as DDR or consider taking specific countermeasures like metal shields or ferrite sheets to reduce the interference.



Take care of interaction between co-located RF systems like LTE sidebands on 2.4 GHz band. Transmitted power may interact or disturb the performance of NORA-B1 modules.

### 6.3.3 On-board antenna (NORA-B106 and NORA-B126 only)

To reach an optimum operating performance, follow these instructions:

- The module should be placed in the center of an edge of the host PCB, preferably on the longest edge. Placing the module in or near a corner will distort the radiation pattern and reduce performance.
- A large ground plane on the host PCB is a prerequisite for good antenna performance. It is recommended to have the ground plane extending at least 10 mm on the three sides of the module that are not against the edge. See also [Figure 10](#).
- The host PCB should include a full GND plane underneath the entire module, with a ground keep-out under the antenna according to the description in [Figure 11](#).
- NORA-B106 has six extra GND pads under the antenna that need to be connected for good antenna performance. Detailed measurements of the footprint including these extra GND pads can be found in the NORA-B1 series data sheet [\[1\]](#).
- High / large parts including metal shall not be placed closer than 10 mm to the module antenna.
- The module is designed to accommodate a small amount of material near the antenna, such as thin (1-2 mm) plastic enclosures, with minor effect. A large amount of dielectric material near the antenna area can detune the antenna, reducing performance.
- Ensure all ground pads are well connected to the ground plane via wide traces and/or stitching vias
- Ensure the antenna keep-out is followed on all layers.
- Designs that accommodate the other NORA modules may also use this keep-out area to provide a common host PCB for different antenna arrangements.

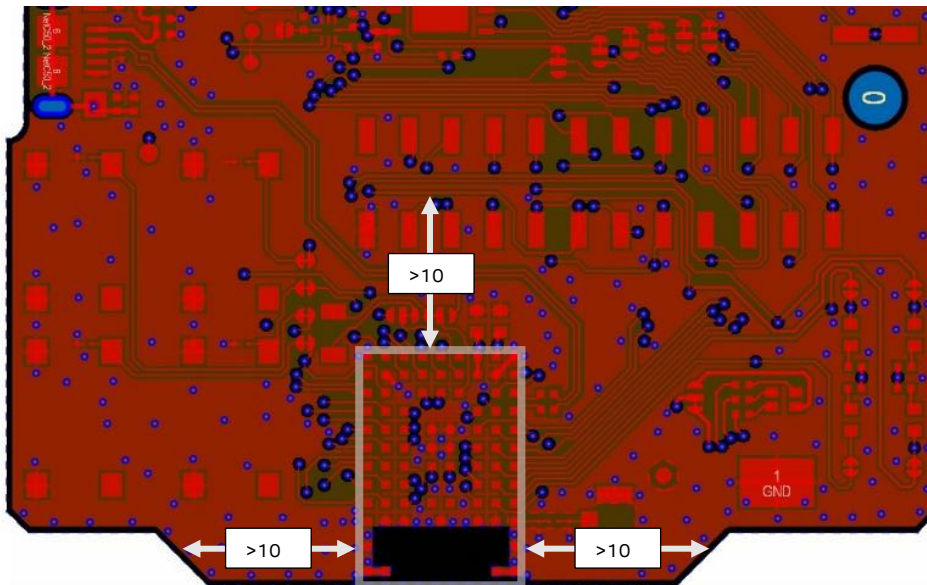

Figure 10: Extend GND plane outside the NORA-B106 and NORA-B126 modules

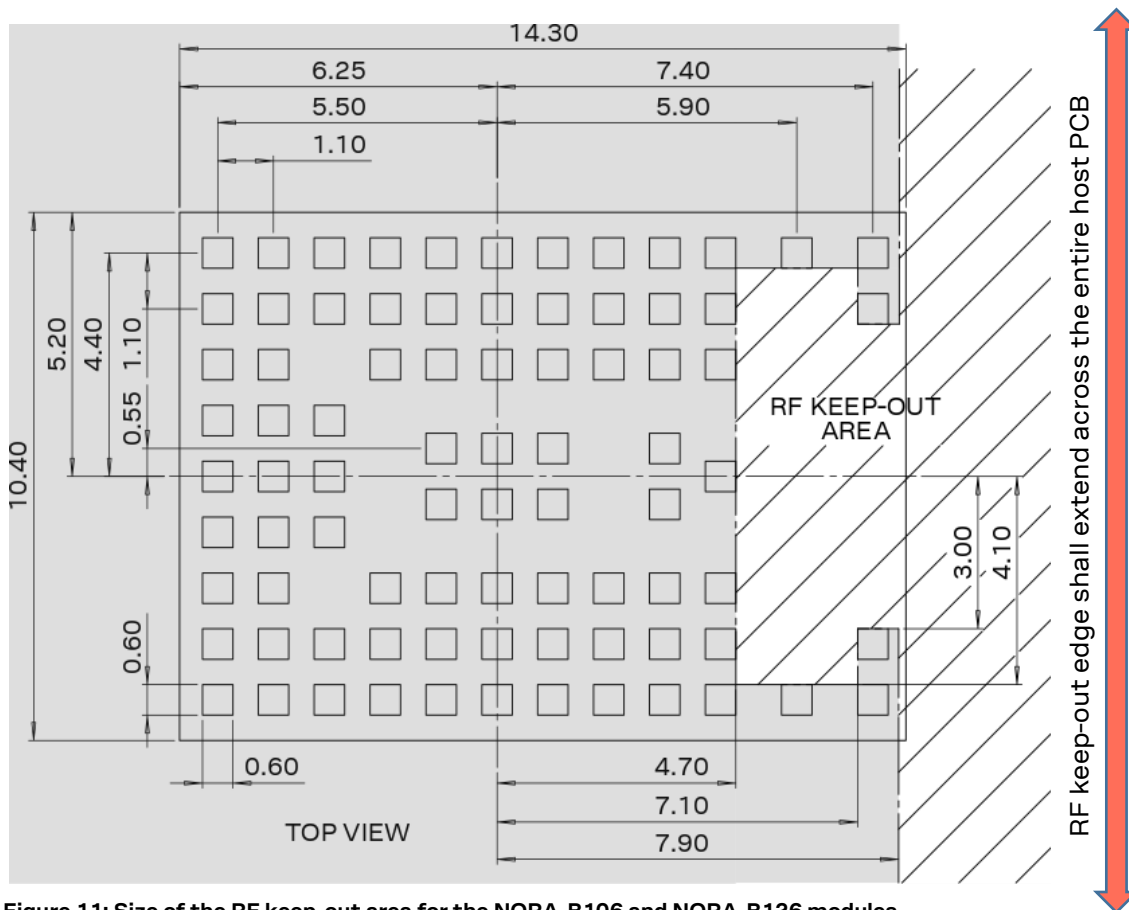

Figure 11: Size of the RF keep-out area for the NORA-B106 and NORA-B126 modules

## 6.4 Supply interfaces

### 6.4.1 Module supply design

A good connection of the module's **VDD** and/or **VDDH** pins with DC supply source is required for proper module operation. The guidelines are summarized below:

- The **VDD** and **VDDH** connections must be sufficient to support the maximum current of the application.
- The **VDD** and **VDDH** connections must be routed through a PCB area separated from sensitive analog signals and sensitive functional units. It is a good practice to interpose at least one layer of PCB ground between the **VDD** track and other signal routing.

There is no strict requirement for adding bypass capacitance to the supply net close to the module. But depending on the layout of the supply net and other consumers on the same net, capacitors might still be beneficial. Though the **GND** pins are internally connected, connect all the available pins to solid ground on the application board, as a good (low impedance) connection to an external ground can minimize power loss and improve RF and thermal performance.

NORA-B12 modules connect **VDD** to **VDDH** internally. **VDD** and **VDDH** should also be connected on the host PCB.

## 6.5 Debug interface

NORA-B1 modules support Serial Wire Debug (SWD) and Serial Wire Viewer. When designing a host board with the NORA-B1, the SWD interface must be made available. The module does not contain any software from the factory and to initially flash the module the SWD interface must be used. During software development, a debug connector to the module is useful.

Figure 12 shows the pinout of the 10-pin, 50 mil pitch connector that is used on the EVK-NORA-B1. This is a compact debug header that can be used on a host board design as well. Other solutions such as spring-loaded connectors (e.g., Tag-Connect-pads [8]) or simple test points can be used as well.

Keep in mind that a minimum of four signals are required for the SWD interface to work: **SWDIO**, **SWDCLK**, **GND** and **VDD** reference are needed for the SWD interface to work. **nRESET** and **SWO** are optional, though suggested. Pin 9 connected to GND is only needed when used with an EVK providing an on-board debugger, such as the EVK-NORA-B1.

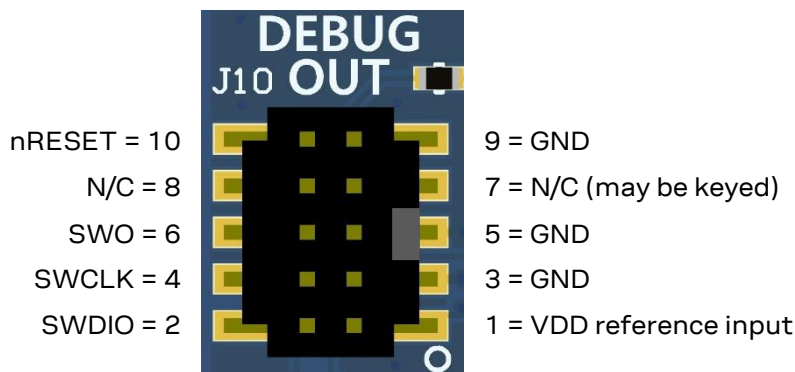

Figure 12: Cortex-M debug connector pin out on EVK-NORA-B1 for SWD

## 6.6 Serial interfaces

### 6.6.1 UART

The layout of the UART bus should be made so that noise injection and cross talk are avoided.

Use hardware flow control with **RTS/CTS** to prevent temporary UART buffer overrun.

**RTS/CTS** flow control signals are active low. The UART can transmit when either of these signals are set to “0” (ON state = low level).

- **CTS** is an input to NORA-B1. The module can transmit when the host sets this signal to “0” (ON state = low level).
- **RTS** is an output from NORA-B1. The module sets this signal to “0” (ON state = low level) when it is ready to receive transmission.

### 6.6.2 USB

The layout of the USB bus should be made so that noise injection and crosstalk are avoided.

The signals **MODUSB\_DP** and **MODUSB\_DM** have controlled 90 Ω differential-pair impedance.

Power and ground connections from the upstream USB host should be filtered and ESD protected. Figure 13 shows one possible USB power filter circuit.

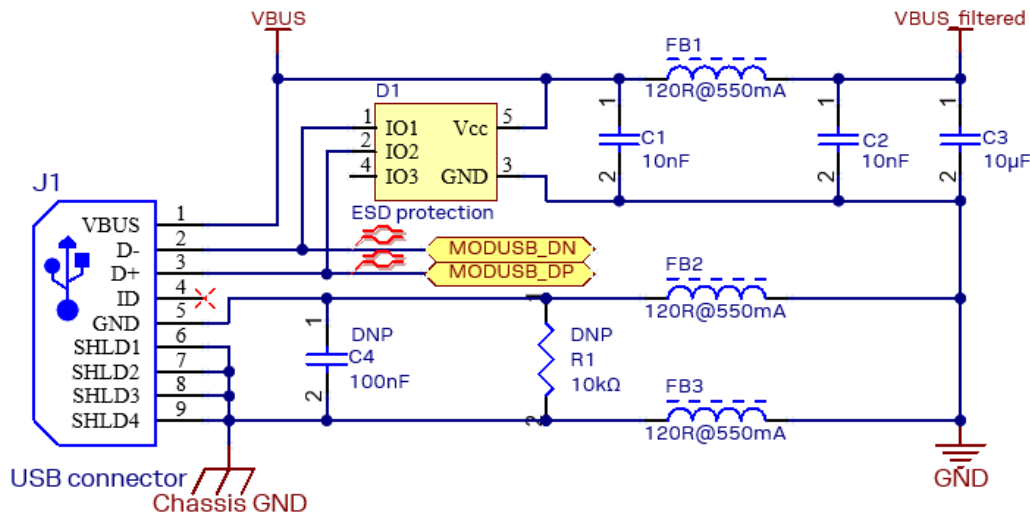

Figure 13: USB device power filtering and signal protection

R1 and/or C4 may only be necessary if EMC tests indicate additional filtering is required. R1 and C4 are marked as do not populate (DNP) here.

USB-IF certified cables are recommended.

### 6.6.3 SPI, QSPI, I2C, I2S, PDM

The layout of these communication buses should be designed so that noise injection and cross talk are avoided.

## 6.7 NFC interface

NORA-B1 modules have been tested with 20 mm x 25 mm flexible trace antenna, so it is recommended that the antenna design is kept close to these measurements. A smaller or larger antenna can be used provided it is tuned to resonate at 13.56 MHz. To comply with European regulatory requirements, the NFC antenna must be placed in such a way that the space between the NORA-B1 module and the remote NFC transmitter is always within three meters during transmission.



The pins for the NFC interface can also be used as normal GPIOs. With NORA-B1 series modules, ensure that the NFC pins are configured correctly in software. Connecting an NFC antenna to the pins when configured as GPIO will damage the module.

The NFC antenna coil must be connected differentially between the **P0.02/NFC1** and **P0.03/NFC2** pins of the device.

Two external capacitors should be used to tune the resonance of the antenna circuit to 13.56 MHz.

The required tuning capacitor value is given by the equations below: an antenna inductance of  $L_{ANT} = 2 \mu\text{H}$  will give tuning capacitors in the range of 130 pF on each pin. For good performance, match the total capacitance on **P0.02/NFC1** and **P0.03/NFC2**.

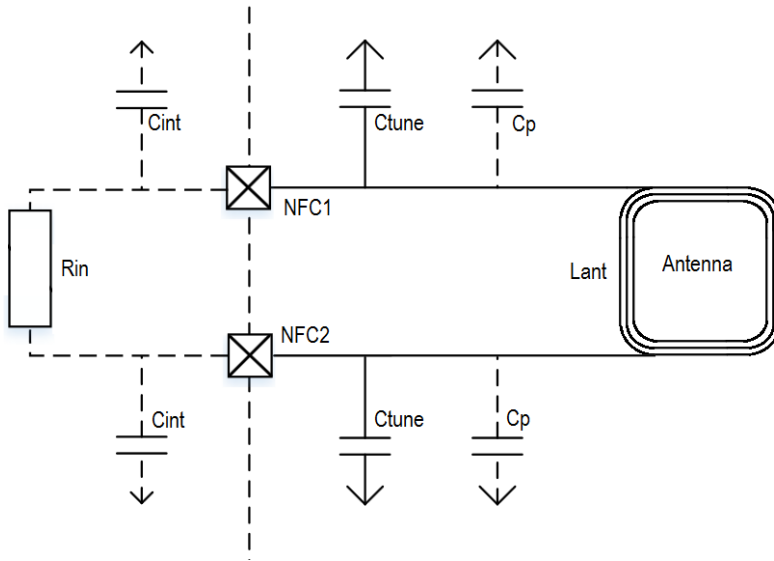

Figure 14: NFC antenna design

$$C'_{tune} = \frac{1}{(2\pi \times 13.56 \text{ MHz})^2 L_{ant}} \text{ where } C'_{tune} = \frac{1}{2} \times (C_p + C_{int} + C_{tune})$$

$$C_{tune} = \frac{2}{(2\pi \times 13.56 \text{ MHz})^2 L_{ant}} - C_p - C_{int}$$

### 6.7.1.1 Battery protection

If the NFC antenna is exposed to a strong NFC field, current may flow in the opposite direction on the supply because of parasitic diodes and ESD structures.

If the battery used does not tolerate a return current, protection must be placed between the battery and the device to protect the battery. A series Schottky diode, or an “ideal diode” chip may be used, such as the Maxim MAX40203AUK+T.

## 6.8 General high-speed layout guidelines

These general design guidelines are considered as best practices and are valid for any bus present in NORA-B1 series modules; designers should prioritize the layout of higher speed buses. Low frequency signals are generally not critical for layout.



One exception is represented by high impedance traces (such as signals driven by weak pull resistors) that may be affected by crosstalk. For those traces, a supplementary isolation of 4w (four times the line width) from other buses is recommended.

### 6.8.1 General considerations for schematic design and PCB floor-planning

- Verify which signal bus requires termination and add series resistor terminations to the schematics.
- Carefully consider the placement of the module with respect to antenna position and host processor.
- Verify with PCB manufacturer allowable stack-ups and controlled impedance dimensioning.



- Verify that the power supply design and power sequence are compliant with NORA-B1 series module specification described in the NORA-B1 data sheet [1].

### 6.8.2 Module placement

- ⚠ Care should be taken not to place components close to the antenna area. Designers should carefully follow the recommendations from the antenna manufacturer about the distance of the antenna versus other parts of the system. Designers should also maximize the distance of the antenna to high-frequency buses like SPI and related components. Otherwise, consider an optional metal shield to reduce interferences that could be picked up by the antenna and subsequently reduce sensitivity in the module.
- An optimized module placement allows better RF performance. For more information about other antenna considerations during module placement, see also [Antenna interface](#).

### 6.8.3 Layout and manufacturing

- Avoid stubs on high-speed signals. Even through-hole vias may have an impact on signal quality.
- Verify the recommended maximum signal skew for differential pairs and length matching of buses.
- Minimize the routing length; longer traces degrade signal performance. Ensure that the maximum allowable length for high-speed buses is not exceeded.
- Ensure that impedance matched traces are correctly routed. Consult with the PCB manufacturer early in the project for proper stack-up definition.
- RF and digital sections should be clearly separated on the board.
- Ground splitting is not allowed below the module.
- Minimize the bus length to reduce potential EMI issues from digital buses.
- All traces (including low speed or DC traces) must couple with a reference plane (**GND** or power); high-speed buses should be referenced to the ground plane. In this case, if the designer needs to change the ground reference, an adequate number of **GND** vias must be added near the transition to provide a low impedance path between the two **GND** layers for the return current.
- High-speed buses are not allowed to change reference plane. If a reference plane change is unavoidable, some capacitors should be added in the area to provide a low impedance return path through the different reference planes.
- Trace routing should keep a distance greater than  $3w$  from the ground plane routing edge.
- Power planes should keep a distance from the PCB edge that is sufficient to route a ground ring around the PCB. The ground ring must then be connected to other layers through vias. The ground ring must not violate the antenna keep-out areas.

## 6.9 Module footprint and paste mask

The mechanical outline of the NORA-B1 series module can be found in the NORA-B1 series data sheet [1]. The proposed land pattern layout reflects the pad's layout of the module.

The Non Solder Mask Defined (NSMD) pad type is recommended over the Solder Mask Defined (SMD) pad type, which implements the solder mask opening  $50\ \mu\text{m}$  larger per side than the corresponding copper pad.

The suggested paste mask layout for NORA-B1 series modules is to follow the same pad layout 1:1 as described in the NORA-B1 series data sheet [1].

- ⚠ These are recommendations only and not specifications. The exact mask geometries, distances, and stencil thicknesses must be adapted to the specific production processes of the customer.

## 6.10 Thermal guidelines

NORA-B1 series modules have been successfully tested from  $-40\text{ }^{\circ}\text{C}$  to  $+105\text{ }^{\circ}\text{C}$ . Although NORA-B1 is a low power device that generates only a small amount of heat during operation, proper grounding is necessary for temperature relief during high ambient temperatures.

## 6.11 ESD guidelines

The immunity of devices integrating NORA-B1 modules to Electrostatic Discharge (ESD) is part of the Electromagnetic Compatibility (EMC) conformity, which is required for products bearing the CE marking, compliant with the R&TTE Directive (99/5/EC), the EMC Directive (89/336/EEC) and the Low Voltage Directive (73/23/EEC) issued by the Commission of the European Community.

Compliance with these directives implies conformity to the following European Norms for device ESD immunity: ESD testing standard CENELEC EN 61000-4-2 and the radio equipment standards ETSI EN 301 489-1, ETSI EN 301 489-7, ETSI EN 301 489-24, the requirements of which are summarized in [Table 15](#).

The ESD immunity test is performed at the enclosure port, defined by ETSI EN 301 489-1 as the physical boundary through which the electromagnetic field radiates. If the device implements an integral antenna, the enclosure port is seen as all insulating and conductive surfaces housing the device. If the device implements a removable antenna, the antenna port can be separated from the enclosure port. The antenna port includes the antenna element and its interconnecting cable surfaces.

The applicability of ESD immunity test to the whole device depends on the device classification as defined by ETSI EN 301 489-1. Applicability of the ESD immunity test to the related device ports or the related interconnecting cables to auxiliary equipment depends on device accessible interfaces and manufacturer requirements, as defined by ETSI EN 301 489-1.

Contact discharges are performed at conductive surfaces, while air discharges are performed at insulating surfaces. Indirect contact discharges are performed on the measurement setup horizontal and vertical coupling planes as defined in CENELEC EN 61000-4-2.

For the definition of integral antenna, removable antenna, antenna port, and the device classification, refer to the ETSI EN 301 489-1. For the contact and air discharges definitions, refer to CENELEC EN 61000 4-2.

Application	Category	Immunity level
All exposed surfaces of the radio equipment and ancillary equipment in a representative configuration	Indirect Contact Discharge	$\pm 8\text{ kV}$

**Table 15: Electromagnetic Compatibility ESD immunity requirements as defined by CENELEC EN 61000-4-2, ETSI EN 301 489-1, ETSI EN 301 489-7, ETSI EN 301 489-24**

NORA-B1 is manufactured with attention to specific standards that minimize the occurrence of ESD events; the highly automated process complies with IEC61340-5-1 (STM5.2-1999 Class M1 devices) standard, and therefore designers should implement proper measures to protect any pin that may be exposed to the end user from ESD events.

Compliance with the standard protection level specified in EN61000-4-2 can be achieved by including ESD protections in parallel to the line, close to areas accessible by the end user.

## 7 Handling and soldering

**⚠** NORA-B1 series modules are Electrostatic Sensitive Devices that demand the observance of special handling precautions against static damage. Failure to observe these precautions can result in severe damage to the product.

### 7.1 ESD handling precautions

**⚠** As the risk of electrostatic discharge in the RF transceivers and patch antennas of the module is of particular concern, standard ESD safety practices are prerequisite. See also [Figure 15](#).

Consider also:

- When connecting test equipment or any other electronics to the module (as a standalone or PCB-mounted device), the first point of contact must always be to local GND.
- Before mounting an antenna patch, connect the device to ground.
- When handling the RF pin, do not touch any charged capacitors. Be especially careful when handling materials like patch antennas (~10 pF), coaxial cables (~50-80 pF/m), soldering irons, or any other materials that can develop charges.
- To prevent electrostatic discharge through the RF input, do not touch any exposed antenna area. If there is any risk of the exposed antenna being touched in an unprotected ESD work area, be sure to implement proper ESD protection measures in the design.
- When soldering RF connectors and patch antennas to the RF pin on the receiver, be sure to use an ESD-safe soldering iron (tip).

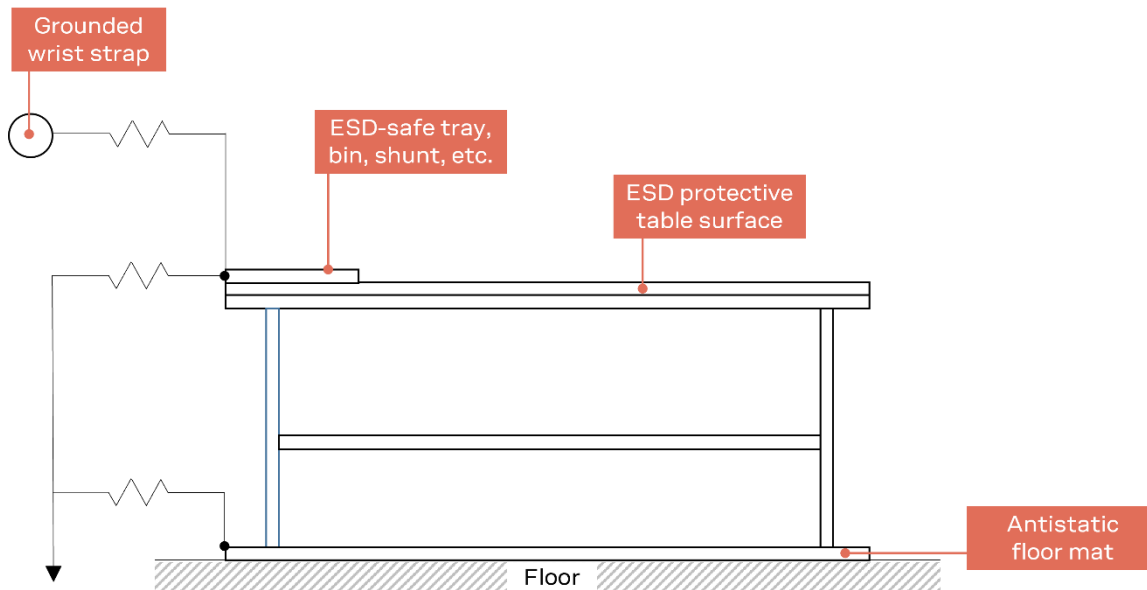

**Figure 15: Standard workstation setup for safe handling of ESD-sensitive devices**

### 7.2 Packaging, shipping, storage, and moisture preconditioning

For information pertaining to reels, tapes or trays, moisture sensitivity levels (MSL), shipment and storage, as well as drying for preconditioning, see also the NORA-B1 series data sheet [\[1\]](#) and Packaging information guide [\[2\]](#).

### 7.3 Soldering

No natural rubbers, hygroscopic materials or materials containing asbestos are employed.

### 7.3.1 Reflow soldering process

NORA-B1 series modules are surface mounted devices supplied on a FR4-type PCB with gold-plated connection pads. The modules are manufactured in a lead-free process using lead-free soldering paste. The thickness of solder resist between the host PCB top side and the bottom side of the NORA-B1 series module must be considered for the soldering process.

NORA-B1 modules are compatible with the industrial reflow profile for common SAC type RoHS solders. No-clean solder paste is strongly recommended. Only one-time reflow processes are allowable for host devices integrating NORA-B1x modules. For further information, [contact](#) u-blox technical support.

The reflow profile used is dependent on the thermal mass of the entire populated PCB, the heat transfer efficiency of the oven, and the type of solder paste that is used. The optimal soldering profile that is used must be trimmed for each case depending on the specific soldering process and PCB layout.

 The parameter target values shown in [Table 16](#) are only general guidelines for a SAC type Pb-free process. The given values are tentative and subject to change. Refer to the JEDEC J-STD-020C [\[9\]](#) standard for further information

Process parameter		Unit	Target
Pre-heat	Ramp up rate to $T_{SMIN}$	K/s	3
	$T_{SMIN}$	°C	150
	$T_{SMAX}$	°C	200
	$t_s$ (from +25 °C)	s	150
	$t_s$ (Pre-heat)	s	60 to 120
Peak	$T_L$	°C	217
	$t_L$ (time above $T_L$ )	s	40 to 60
	$T_P$ (absolute max)	°C	245
Cooling	Ramp-down from $T_L$	K/s	4

Table 16: Recommended reflow profile

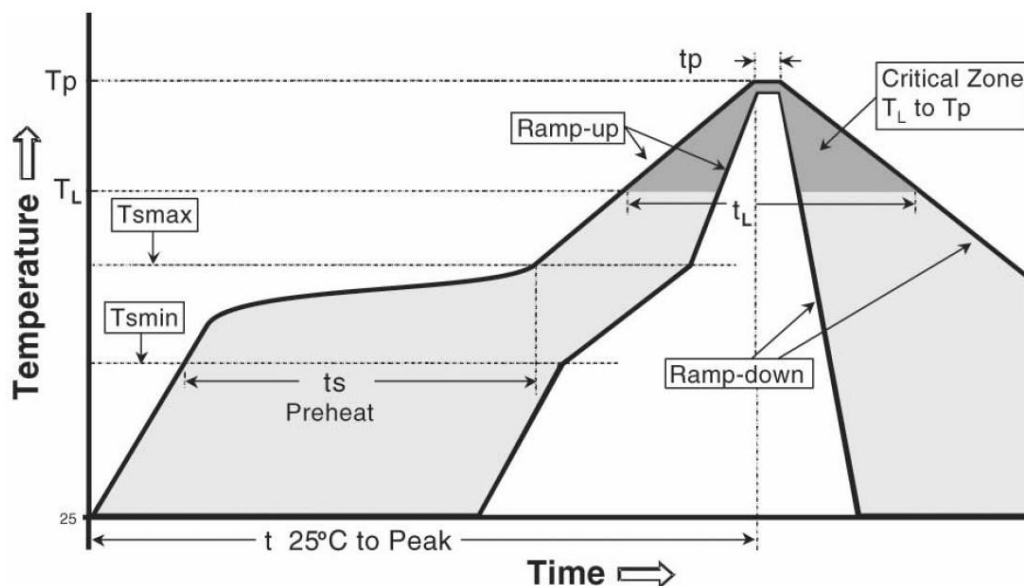

Figure 16: Reflow profile

Lower value of  $T_P$  and slower ramp down rate (2 – 3 °C/sec) is preferred.

### 7.3.2 Cleaning

Cleaning the modules is not recommended. Residues underneath the modules cannot be easily removed with a washing process.

- Cleaning with water will lead to capillary effects where water is absorbed in the gap between the host board and the module. The combination of residues of soldering flux and encapsulated water can lead to short circuits or resistor-like interconnections between neighboring pads. Water will also damage the sticker and the inkjet printed text.
- Cleaning with alcohol or other organic solvents can result in soldering flux residues flooding into the housing, an area that is not accessible for post-wash inspections. The solvent will also damage the sticker and the inkjet printed text.
- Ultrasonic cleaning will permanently damage the module and crystal oscillators in particular.

For best results, use a "no clean" soldering paste and eliminate the need for cleaning stage after the soldering process.

### 7.3.3 Other remarks

- Only a single reflow soldering process is allowed for boards with a module populated on them.
- Boards with combined through-hole (THT) components and surface-mount (SMT) devices may require wave soldering. Only a single wave soldering process is allowed for boards populated with the modules. Miniature Wave Selective Solder processes are preferred over the traditional wave soldering processes.
- Hand soldering is not recommended.
- Rework is not recommended.
- Conformal coating can affect the performance of the module, so it is important to prevent the liquid from flowing into the module. The RF shields do not provide protection for the module from coating liquids with low viscosity, and so care is required in applying the coating. Conformal coating of the module will void the module warranty.
- Grounding metal covers: Attempts to improve grounding by soldering ground cables, wick, or other forms of metal strips directly onto the EMI covers are made at the customer's own risk and will void the module warranty. The numerous ground pins included in the module design are adequate to provide optimal immunity to interferences.
- Take care when handling the NORA-B1. Applying force to the module might damage the RF shield.
- The module contains components that are sensitive to ultrasonic waves. The use of any ultrasonic processes, such as cleaning, welding, etc., can damage the module. Use of ultrasonic processes on an end-product integrating this module will void the warranty.

## 8 Regulatory information and requirements

NORA-B1 modules are certified for use in different regions and countries, such as Europe, USA, and Canada. See also the NORA-B1 series data sheet [1] for a list of approved countries/regions where NORA-B1 modules are approved for use. Each market has its own regulatory requirements that must be fulfilled, and NORA-B1 series modules must comply with the requirements for a radio transmitter in each of the listed markets.

In some cases, limitations must be placed on the end-product that integrates a NORA-B1 module to comply with the regulatory requirements. This chapter describes the limitations and requirements that a module integrator must take into consideration. The chapter is divided into different sections for each market. The checklist at the end of this chapter summarizes some of the requirements for each market.

 This information in this chapter reflects u-blox' interpretation of different regulatory requirements of a radio device in each country/region. It does not cover all the requirements placed on an end-product that uses the radio module of u-blox or any other manufacturer.

### 8.1 ETSI – European market (NORA-B12 pending)

#### 8.1.1 Compliance statement

Detailed information about European Union regulatory compliance for NORA-B1 series modules is available in the NORA-B1 Declaration of Conformity [6].

 Module integrators are required to make their own “Declaration of Conformity”, in which test standards and directives that are tested and fulfilled by the end-product are listed.

#### 8.1.2 NORA-B1 software security considerations

 An end user cannot be allowed to change the software on the NORA-B1 module to any unauthorized software or modify the existing software in an unauthorized way. A module integrator must consider this in the end-product design. Typically, the SWD interface (the **SWDCLK** and **SWDIO** pins) must not be accessible by the end user.

#### 8.1.3 Output power limitation

The Radio Equipment Directive requires radio transmitters that have an Equivalent Isotropic Radiated Power (EIRP) of 10 dBm or more, to either implement an adaptivity feature or reduce its medium utilization.

NORA-B1 series modules are based on the Nordic Semiconductor nRF5340 chip, which supports multiple radio protocols such as Bluetooth low energy, IEEE 802.15.4 with Thread, etc.

Since Bluetooth low energy does not support either adaptivity or reduced medium utilization, a NORA-B1 Bluetooth LE implementation on the European market must have an EIRP of less than 10 dBm.

 In the European market, it is the end-product manufacturer that holds the responsibility that these limitations are followed. If the u-blox module integrator is not the end-product manufacturer, the module integrator should make sure that this information is shared with the end-product manufacturer.

Radio protocols, based on IEEE 802.15.4 that supports adaptivity, are allowed an EIRP of 10 dBm or higher.

EIRP is calculated as:

$$EIRP(dBm) = P_{TX}(dBm) - L(dB) + G_{TX}(dBi)$$

Where,  $P_{TX}$  is the output power of the transmitter,  $L$  is the path loss of the transmission line between the transmitter and antenna, and  $G_{TX}$  is the maximum gain of the transmit antenna. Consider the following for each of these components:

- Output power:
  - The output power setting of the NORA-B1 module. An end-product user must not be able to increase the setting above the 10 dBm EIRP limit by sending configuration commands etc. for protocols that do not support an adaptivity feature (e.g., Bluetooth LE).
  - The operating temperature of the end-product. The output power of a transmitter is typically increased as the ambient temperature is lowered. The operating temperature range of NORA-B1 is  $-40$  to  $+105$  °C, and across this range the output power can typically vary by 1 dB. The output power at the lowest operating temperature (yielding the highest output power) must be considered for the EIRP calculation.
- Path loss: Long antenna cables or PCB traces, RF switches, etc. will attenuate the power reaching the antenna. This path loss should be measured and taken into consideration for the EIRP calculation.
- Antenna gain: The maximum gain of the transmit antenna must be considered for the EIRP calculation.

### 8.1.4 Safety Compliance

 To fulfill the EN 60950-1 safety standard, NORA-B1 series modules must be supplied with a Class-2 Limited Power Source.

## 8.2 FCC/ISED – US/Canadian markets

### 8.2.1 Compliance statements – US

Model	FCC ID	ISED Certification Number
NORA-B100	XPYNORAB1	8595A-NORAB1
NORA-B101	XPYNORAB1	8595A-NORAB1
NORA-B106	XPYNORAB1	8595A-NORAB1
NORA-B120	XPYNORAB12	8595A-NORAB12
NORA-B121	XPYNORAB12	8595A-NORAB12
NORA-B126	XPYNORAB12	8595A-NORAB12

**Table 17: FCC IDs and ISED Certification Numbers for the NORA-B1 series modules**

NORA-B1 series modules have received Federal Communications Commission (FCC) CFR47 Telecommunications, Part 15 Subpart C “Intentional Radiators” modular approval in accordance with Part 15.247 Modular Transmitter approval. Limited module procedures are not applicable.

NORA-B1 series modules and its antenna(s) must not be co-located or operating in conjunction with any transmitter.

NORA-B1 series modules comply with Part 15 of the FCC Rules and with Industry Canada license-exempt RSS standard(s). Operation is subject to the following two conditions:

1. This device may not cause harmful interference, and
2. This device must accept any interference received, including interference that may cause undesired operation.

This equipment has been tested and found to comply with the limits for a Class B digital device, pursuant to Part 15 of the FCC Rules. These limits are designed to provide reasonable protection against harmful interference in a residential installation. This equipment generates, uses and can radiate radio frequency energy and, if not installed and used in accordance with the instructions, may cause harmful interference to radio communications. However, there is no guarantee that the interference will not occur in a particular installation. If this equipment does cause harmful interference to radio or television reception, which can be determined by turning the equipment off and on, the user is encouraged to correct the interference using either one or more of the following measures:

- Reorient or relocate the receiving antenna
- Increase the separation between the equipment and receiver
- Connect the equipment into an outlet on a circuit different from that to which the receiver is connected.
- Consult the dealer or an experienced radio/TV technician for help.

 NORA-B1 modules are for OEM integrations only. The end-product must be professionally installed in such a manner that only the authorized antennas can be used. See also [Antenna selection](#).

 Any changes to hardware, hosts or co-location configuration may require new radiated emission and SAR evaluation and/or testing. Any changes or modifications NOT explicitly APPROVED by u-blox may cause the NORA-B1 module to cease to comply with the FCC rules part 15 thus void the user's authority to operate the equipment on the US market.

## 8.2.2 Compliance statements – Canada

### 8.2.2.1 NORA-B10

This radio transmitter [IC: 8595A-NORAB1] has been approved by Innovation, Science and Economic Development Canada to operate with the antenna types listed in the [Pre-approved antennas list](#), with the maximum permissible gain indicated. Antenna types not included in this list that have a gain greater than the maximum gain indicated for any type listed are strictly prohibited for use with this device.

Cet émetteur radio [IC : 8595A-NORAB1] a été approuvé par Innovation, Sciences et Développement économique Canada pour fonctionner avec les types d'antennes énumérés dans la [liste des antennes préapprouvées](#), avec le gain maximal admissible indiqué. Les types d'antenne non inclus dans cette liste qui ont un gain supérieur au gain maximum indiqué pour tout type répertorié sont strictement interdits pour une utilisation avec cet appareil.

### 8.2.2.2 NORA-B12

This radio transmitter [IC: 8595A-NORAB12] has been approved by Innovation, Science and Economic Development Canada to operate with the antenna types listed in the [Pre-approved antennas list](#), with the maximum permissible gain indicated. Antenna types not included in this list that have a gain greater than the maximum gain indicated for any type listed are strictly prohibited for use with this device.

Cet émetteur radio [IC : 8595A-NORAB12] a été approuvé par Innovation, Sciences et Développement économique Canada pour fonctionner avec les types d'antennes énumérés dans la [liste des antennes préapprouvées](#), avec le gain maximal admissible indiqué. Les types d'antenne non inclus dans cette liste qui ont un gain supérieur au gain maximum indiqué pour tout type répertorié sont strictement interdits pour une utilisation avec cet appareil.



## 8.2.3 RF Exposure

### 8.2.3.1 NORA-B10

NORA-B10 series modules comply with the FCC radiation exposure limits and the requirements of IC RSS-102 issue 5 radiation exposure limits set forth for an uncontrolled environment.

Having a separation distance of minimum 10 mm between the user and/or bystander and the antenna and /or radiating element ensures that the maximum output power of NORA-B1 is below the SAR test exclusion limits presented in KDB 447498 D01v06 [14] (US market limits).

Having a separation distance of minimum 10 mm between the user and/or bystander and the antenna and /or radiating element ensures that the output power (EIRP.) of NORA-B1 is below the SAR evaluation Exemption limits defined in RSS-102 issue 5 (Canadian market limits).

KDB 996369 D03 section 2.4 [15] (limited module procedures) is not applicable to the NORA-B1 series modules.

### 8.2.3.2 NORA-B12

NORA-B12 series modules comply with FCC RF radiation exposure limits set forth for an uncontrolled environment. This compliance to FCC radiation exposure limits for an uncontrolled environment, and minimum of 20cm separation between antenna and body.

The host product manufacturer would provide the above information to end users in their end-product manuals.

Radio Frequency Exposure Statement for IC: (IC RF Exposure)

The device has been evaluated to meet general RF exposure requirements. The device can be used in mobile exposure conditions. The min separation distance is 20cm.

Déclaration d'exposition aux radiofréquences pour IC:

L'appareil a été évalué pour répondre aux exigences générales en matière d'exposition aux RF. L'appareil peut être utilisé dans des conditions d'exposition mobiles. La distance de séparation minimale est de 20 cm.

## 8.2.4 Antenna selection

KDB 996369 D03 section 2.5 [15] (trace antenna designs) is not applicable to the NORA-B1 series modules.

For NORA-B101, the external antenna connector (U.FL. connector) antenna reference design layout specified in Appendix B must be followed to comply with the NORA-B1 FCC/ISED modular approval. Use only those antennas that have been authorized for use with NORA-B1. See also the [pre-approved antennas list](#).

u-blox has provided these pre-approved antennas and reference design to enable quick time to market, but it is possible and encouraged for customers to add their own antennas and connector designs. These must be approved by u-blox and in some cases tested. [Contact](#) your local u-blox support for more information about this process.

## 8.2.5 End-product verification requirements

 The modular transmitter approval of NORA-B1, or any other radio module, does not exempt the end-product from being evaluated against applicable regulatory demands.

The evaluation of the end-product shall be performed with the NORA-B1 module installed and operating in a way that reflects the intended end-product use case. The upper frequency

measurement range of the end-product evaluation is the 5th harmonic of 2.4 GHz as declared in 47 CFR Part 15.33 (b)(1).

The following requirements apply to all products that integrate a radio module:

- **Subpart-B - UNINTENTIONAL RADIATORS**  
To verify that the composite device of host and module comply with the requirements of FCC part 15B, the integrator shall perform sufficient measurements using ANSI 63.4-2014.
- **Subpart-C - INTENTIONAL RADIATORS**  
It is required that the integrator carries out sufficient verification measurements using ANSI 63.10-2013 to validate that the fundamental and out of band emissions of the transmitter part of the composite device complies with the requirements of FCC part 15C.

When the items listed above are fulfilled, the end-product manufacturer can use the authorization procedures as mentioned in Table 1 of 47 CFR Part 15.101, before marketing the end-product. This means the customer must either market the end-product under a Suppliers Declaration of Conformity (SDoC) or to certify the product using an accredited test lab. [Contact](#) your local u-blox support for more information about test requirements.

## 8.2.6 End-product labelling requirements

### 8.2.6.1 US market

#### **NORA-B10 is assigned the FCC ID number: XPYNORAB1**

The final host device, into which this RF Module is integrated must be labeled with an auxiliary label stating the FCC ID of the RF Module, such as:

Contains FCC ID: XPYNORAB1  
This device complies with part 15 of the FCC rules. Operation is subject to the following two conditions:

1. This device may not cause harmful interference, and
2. This device must accept any interference received, including interference that may cause undesired operation.

#### **NORA-B12 is assigned the FCC ID number: XPYNORAB12**

The final host device, into which this RF Module is integrated must be labeled with an auxiliary label stating the FCC ID of the RF Module, such as:

Contains FCC ID: XPYNORAB12  
This device complies with part 15 of the FCC rules. Operation is subject to the following two conditions:

1. This device may not cause harmful interference, and
2. This device must accept any interference received, including interference that may cause undesired operation.

The following statement must be included in the end-user manual or guide:

Changes or modifications to this unit not expressly approved by the party responsible for compliance could void the user's authority to operate the equipment.

This equipment has been tested and found to comply with the limits for a Class B digital device, pursuant to part 15 of the FCC Rules. These limits are designed to provide reasonable protection against harmful interference in a residential installation. This equipment generates uses and can radiate radio frequency energy and, if not installed and used in accordance with the instructions, may cause harmful interference to radio communications. However, there is no guarantee that interference will not occur in a particular installation. If this equipment does cause harmful interference to radio or television reception, which can be determined by turning the equipment off and on, the user is encouraged to try to correct the interference by one or more of the following measures:

- Reorient or relocate the receiving antenna.
- Increase the separation between the equipment and receiver.
- Connect the equipment into an outlet on a circuit different from that to which the receiver is connected.
- Consult the dealer or an experienced radio/TV technician for help.

When the device is so small or for such use that it is not practicable to place the statement above on it, the information shall be placed in a prominent location in the instruction manual or pamphlet supplied to the user or, alternatively, shall be placed on the container in which the device is marketed.

In case, where the final product will be installed in locations where the end user is unable to see the FCC ID and/or this statement, the FCC ID and the statement shall also be included in the end-product manual.

### 8.2.6.2 Canadian market

The NORA-B1 module is certified for use in Canada under Innovation, Science and Economic Development Canada (ISED) Radio Standards Specification (RSS) RSS-247 Issue 2 and RSSGen. The host product shall be properly labelled to identify the modules within the host product.

The Innovation, Science and Economic Development Canada certification label of a module shall be clearly visible at all times when installed in the host product; otherwise, the host product must be labelled to display the Innovation, Science and Economic Development Canada certification number for the module, preceded by the word "Contains" or similar wording expressing the same meaning, such as:

NORA-B10:

Contains transmitter module IC: 8595A-NORAB1

This device contains licence-exempt transmitter(s)/receiver(s) that comply with Innovation, Science and Economic Development Canada's licence-exempt RSS(s). Operation is subject to the following two conditions:

1. This device may not cause interference.
2. This device must accept any interference, including interference that may cause undesired operation of the device.

NORA-B12:

Contains transmitter module IC: 8595A-NORAB12

This device contains licence-exempt transmitter(s)/receiver(s) that comply with Innovation, Science and Economic Development Canada's licence-exempt RSS(s). Operation is subject to the following two conditions:

1. This device may not cause interference.
2. This device must accept any interference, including interference that may cause undesired operation of the device.

Le périphérique hôte final, dans lequel ce module RF est intégré "doit être étiqueté avec l'étiquette auxiliaire indiquant le CI du module RF, tel que:

NORA-B10:

Contient le module émetteur IC: 8595A-NORAB1

L'émetteur/récepteur exempt de licence contenu dans le présent appareil est conforme aux CNR d'Innovation, Sciences et Développement économique Canada applicables aux appareils radio exempts de licence. L'exploitation est autorisée aux deux conditions suivantes:

1. L'appareil ne doit pas produire de brouillage;
2. L'utilisateur de l'appareil doit accepter tout brouillage radioélectrique subi, même si le brouillage est susceptible d'en compromettre le fonctionnement.

NORA-B12:

Contient le module émetteur IC: 8595A-NORAB12

L'émetteur/récepteur exempt de licence contenu dans le présent appareil est conforme aux CNR d'Innovation, Sciences et Développement économique Canada applicables aux appareils radio exempts de licence. L'exploitation est autorisée aux deux conditions suivantes:

1. L'appareil ne doit pas produire de brouillage;
2. L'utilisateur de l'appareil doit accepter tout brouillage radioélectrique subi, même si le brouillage est susceptible d'en compromettre le fonctionnement.

## 8.3 MIC - Japanese market (NORA-B12 pending)

### 8.3.1 Compliance statement

NORA-B1 series modules comply with the Japanese Technical Regulation Conformity Certification of Specified Radio Equipment (ordinance of MPT N°. 37, 1981), Article 2, Paragraph 1:

- Item “9” 2.4 GHz band wide band low power data communication system”.

### 8.3.2 48-bit address requirement

Radio devices on the Japanese market, which can be connected directly or indirectly to a public network, must have an at least 48-bit (12 hex) long ID code. In practice this means that the device addresses used in the radio communication protocol (Bluetooth, Thread, Zigbee, Gazell etc.) must be at least 48 bits.

Note that this requirement is not applicable to devices only intended for use in private or personal networks.

The requirements on a NORA-B1 design depend on the used radio protocol(s):

- The Bluetooth protocol uses 48-bit addressing, no additional effort is needed.
- IEEE 802.15.4 based protocols, such as Thread and Zigbee, use (at the MAC layer) a combination of 16- and 64-bit addresses. The 16-bit (‘short’) address can be used to reduce overhead in communications. However, each device must have a 64-bit (‘extended’) address and can always be accessed using this address. Because of this no additional effort is needed when using an 802.15.4 based protocol.
- Protocols based on the 2.4 GHz proprietary mode do not necessarily follow any standards, so there is no guarantee that the 48-bit addressing requirement will be fulfilled. If the end-product can be connected to, or accessed through, a public network using a proprietary protocol, it is the end-product manufacturer’s responsibility to make sure that the protocol uses at least 48-bit addressing.

 Failure to comply with these requirements will void the NORA-B1 Japan certification, and it will be illegal to place the end-product on the Japanese market.

### 8.3.3 End-product labelling requirement

When a product integrating a NORA-B10 series module is placed on the Japanese market the product must be affixed with a label with the “Giteki” marking as shown in [Figure 17](#). The marking must be visible for inspection.

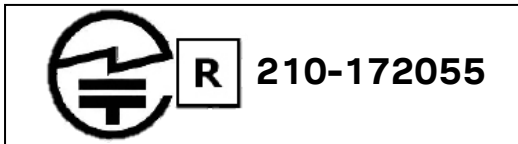

Figure 17: Giteki mark, **[R]** and the NORA-B10 MIC certification number

The required minimum size of the Giteki mark is Ø3.0 mm.

NORA-B12 Japanese certification is pending.

Model	MIC ID
NORA-B100	R210-172055
NORA-B101	R210-172055
NORA-B106	R210-172055

Model	MIC ID
NORA-B120	TBD
NORA-B121	TBD
NORA-B126	TBD

Table 18: NORA-B1 series MIC ID certification numbers

### 8.3.4 End-product user manual requirement

As the MIC ID is not included on the NORA-B1 series label, the end-product manufacturer must include a copy of the NORA-B1 Japan Radio Certificate to the end-product technical documentation.

[Contact](#) your local u-blox support team to obtain a copy of the NORA-B1 Japan Radio Certificate.

## 8.4 NCC – Taiwanese market (NORA-B12 pending)

### 8.4.1 Compliance statements

- 經型式認證合格之低功率射頻電機，非經許可，公司、商號或使用者均不得擅自變更頻率、加大功率或變更原設計之特性及功能。
- 低功率射頻電機之使用不得影響飛航安全及干擾合法通信；經發現有干擾現象時，應立即停用，並改善至無干擾時方得繼續使用。前項合法通信，指依電信法規定作業之無線電通信。低功率射頻電機須忍受合法通信或工業、科學及醫療用電波輻射性電機設備之干擾。

Statement translation:

- Without permission granted by the NCC, any company, enterprise, or user is not allowed to change frequency, enhance transmitting power, or alter original characteristic as well as performance to an approved low power radio-frequency device.
- The low power radio-frequency devices shall not influence aircraft security and interfere legal communications; If found, the user shall cease operating immediately until no interference is achieved. The said legal communications means radio communications is operated in compliance with the Telecommunications Act. The low power radio-frequency devices must be susceptible with the interference from legal communications or ISM radio wave radiated devices.

### 8.4.2 End-product labelling requirement

When a product integrating a NORA-B1 series module is placed on the Taiwanese market, the product must be affixed with a label or marking containing at least the following information:

#### 8.4.2.1 NORA-B100 label

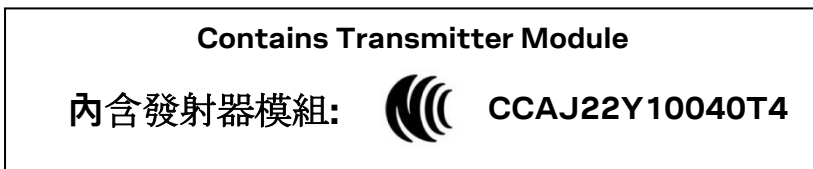

Figure 18: Example of an end-product label that includes a NORA-B100 module

#### 8.4.2.2 NORA-B101 label

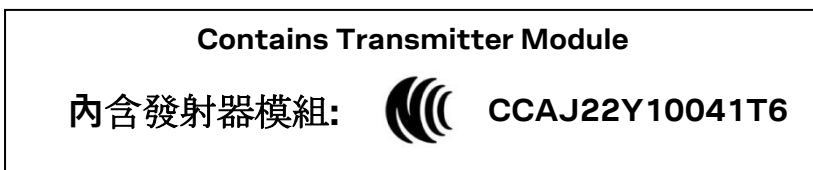

Figure 19: Example of an end-product label that includes a NORA-B101 module

### 8.4.2.3 NORA-B106 label

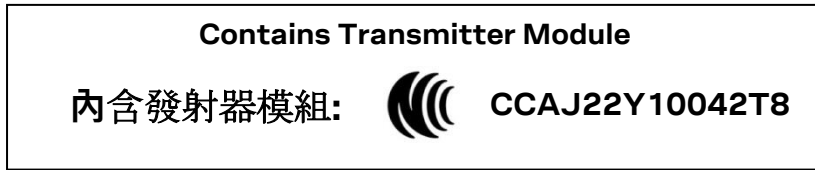

Figure 20: Example of an end-product label that includes a NORA-B106 module

Any similar wording that expresses the same meaning may be used. The marking must be visible for inspection.

Note that each NORA-B1 module variant has its own certification number.

Module variant	NCC ID
NORA-B100	CCAJ22Y10040T4
NORA-B101	CCAJ22Y10041T6
NORA-B106	CCAJ22Y10042T8
NORA-B100	TBD
NORA-B101	TBD
NORA-B106	TBD

Table 19: NORA-B1 series NCC ID certification numbers

## 8.5 KCC – South Korean market (NORA-B12 pending)

### 8.5.1 Compliance statement

NORA-B1 series modules are certified by the Korea Communications Commission (KCC).

### 8.5.2 End-product labeling requirements

When a product containing a NORA-B1 series module is placed on the South Korean market, the product must be affixed with a label or marking containing the KCC logo and certification number as shown in the following figures:



Figure 21: Sample label of an end-product that includes a NORA-B10 series module

South Korea certification for NORA-B12 is pending.

Model	KCC ID
NORA-B100	R210-172055
NORA-B101	R210-172055
NORA-B106	R210-172055
NORA-B120	TBD
NORA-B121	TBD
NORA-B126	TBD

Table 20: NORA-B1 series KCC certification numbers

### 8.5.3 End-product user manual requirements

The KCC logo and NORA-B1 certification numbers described in the [End-product labeling requirements](#) must also be included in the end-product user manual.

## 8.6 ANATEL Brazil compliance (NORA-B12 pending)

NORA-B10:

When a product containing a NORA-B10 module is placed on the Brazilian market, the product must be affixed with a label or marking containing the ANATEL logo, NORA-B10 Homologation number: 08573-21-05903 and a statement claiming that the device may not cause harmful interference but must accept it (Resolution No 506).



“Este equipamento opera em caráter secundário, isto é, não tem direito a proteção contra interferência prejudicial, mesmo de estações do mesmo tipo, e não pode causar interferência a sistemas operando em caráter primário.”

NORA-B12:

When a product containing a NORA-B12 module is placed on the Brazilian market, the product must be affixed with a label or marking containing the ANATEL logo, NORA-B12 Homologation number: TBD and a statement claiming that the device may not cause harmful interference but must accept it (Resolution No 506).



“Este equipamento opera em caráter secundário, isto é, não tem direito a proteção contra interferência prejudicial, mesmo de estações do mesmo tipo, e não pode causar interferência a sistemas operando em caráter primário.”

Statement translation:

“This equipment operates on a secondary basis and, consequently, must accept harmful interference, including from stations of the same kind, and may not cause harmful interference to systems operating on a primary basis.”

When the device is so small or for such use that it is not practicable to place the statement above on it, the information shall be placed in a prominent location in the instruction manual or pamphlet supplied to the user or, alternatively, shall be placed on the container in which the device is marketed.

In case, where the final product will be installed in locations where the end-user is not able to see the ANATEL logo, NORA-B1 Homologation number and/or this statement, the ANATEL logo, NORA-B1 Homologation number and the statement shall also be included in the end-product manual.

Model	ANATEL ID
NORA-B100	R210-172055
NORA-B101	R210-172055
NORA-B106	R210-172055
NORA-B120	TBD
NORA-B121	TBD
NORA-B126	TBD

**Table 21: NORA-B1 series ANATEL certification numbers**

## 8.7 Australia and New Zealand regulatory compliance (NORA-B12 pending)



NORA-B1 modules are compliant with AS/NZS 4268:2016 standard – Radio equipment and systems – Short range devices – Limits and methods of standard measurement made by the Australian Communications and Media Authority (RCM).

The NORA-B1 module test reports can be used as part of evidence in obtaining permission the Regulatory Compliance Mark (RCM). To meet overall Australian and/or New Zealand compliance on the end-product, the integrator must create a compliance folder containing all the relevant compliance test reports.

More information on registration as a Responsible Integrator and labeling requirements will be found at the following websites:

Australian Communications and Media Authority web site <http://www.acma.gov.au/>.

New Zealand Radio Spectrum Management Group web site [www.rsm.govt.nz](http://www.rsm.govt.nz).

## 8.8 South Africa regulatory compliance (NORA-B12 pending)

NORA-B1 modules are compliant and certified by the Independent Communications Authority of South Africa (ICASA). End-products that are made available for sale or lease or is supplied in any other manner in South Africa shall have a legible label permanently affixed to its exterior surface. The label shall have the ICASA logo and the ICASA issued license number as shown in the figure below. The minimum width and height of the ICASA logo shall be 3 mm. The approval labels must be purchased by the customer’s local representative directly from the approval authority ICASA. A sample of a NORA-B1 ICASA label is included below:

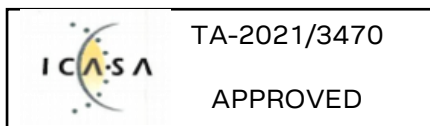

Model	ICASA ID
NORA-B100	TA-2021/3470
NORA-B101	TA-2021/3470
NORA-B106	TA-2021/3470
NORA-B120	TBD
NORA-B121	TBD
NORA-B126	TBD

**Table: NORA-B1 series ICASA certification numbers**



More information on registration as a Responsible Integrator and labeling requirements will be found at the following website:

Independent Communications Authority of South Africa (ICASA) website - <https://www.icasa.org.za>

## 8.9 Integration checklist

The following checklist can be used to get an overview of the requirements of each market. It is in no way a complete list of all actions required but should cover the essentials of integrating a NORA-B1 radio module.

### General requirements

- The SWD interface cannot be accessed by an end-product user.

### Specific to the European market

- The EIRP of the end-product is measured to be within the applicable limit.
- A Class-2 limited power source is used to supply the module.
- A Declaration of Conformity has been created.

### Specific to the US and Canadian markets

- The fundamental and out of band emissions of the end-product has been measured and complies with the applicable limits.
- An SDoC has been created, or an accredited test lab has been used to certify the end-product.
- The end-product labelling requirements are fulfilled.
- The end-product documentation requirements are fulfilled. The necessary legal statements are included at a prominent location in the user guide.

### Specific to the Japanese market

- If applicable, the product fulfills the 48-bit addressing requirements.
- The end-product labelling requirements are fulfilled.
- A copy of the NORA-B1 Japan Radio Certificate has been included in the end-product technical documentation.

### Specific to the Taiwanese market

- The end-product labelling requirements are fulfilled.

### Specific to the South Korean market

- The end-product labelling requirements are fulfilled.
- The end-product user manual requirements are fulfilled.

### Specific to the Brazilian market

- The end-product labelling requirements are fulfilled.
- The end-product user manual requirements are fulfilled.

### Specific to the Australian and/or New Zealand markets

- The end-product labelling requirements are fulfilled.
- A compliance folder containing all the relevant compliance test reports is created and available.

### Specific to the South African market

- The end-product labelling requirements are fulfilled.

## 8.10 Pre-approved antennas list

This section lists the different external antennas that are pre-approved for use together with NORA-B1 series modules.

Note that not all antennas are approved for use in all markets/regions.

### 8.10.1 Antenna accessories

Name	U.FL to Reverse Polarity SMA adapter cable
Applicable modules	NORA-B100, NORA-B101, NORA-B120, NORA-B121 For information about how to integrate the U.FL connector with the NORA-B101 <b>ANT</b> pin, see also <a href="#">Antenna reference design</a> . It is necessary to follow this reference design to comply with the NORA-B1 FCC/ISED modular approvals.
Connector	U.FL and Reverse Polarity SMA jack (outer thread and pin)
Impedance	50 $\Omega$
Minimum cable loss	0.5 dB, The cable loss must be above the minimum cable loss to meet the regulatory requirements. Minimum cable length 100 mm.
Comment	The Reverse Polarity SMA connector can be mounted in a panel.
Approval <sup>4</sup>	FCC, IC, RED, MIC, KCC, ANATEL, RCM, NCC, and ICASA



### 8.10.2 Single band antennas

NORA-B106, NORA-B126	
Applicable module	NORA-B106, NORA-B126
Manufacturer	Abracon
Gain	+2 dBi
Impedance	N/A
Size	Integrated into module
Type	PCB trace
Comment	PCB antenna on NORA-B106. Should not be mounted inside a metal enclosure.
Approval <sup>4</sup>	FCC, IC, RED, MIC, KCC, ANATEL, RCM, NCC, and ICASA



FXP72.07.0053A	
Applicable modules	NORA-B100, NORA-B101, NORA-B120, NORA-B121 For information about how to integrate the U.FL connector with the NORA-B101 <b>ANT</b> pin, see also <a href="#">Antenna reference design</a> . It is necessary to follow this reference design to comply with the NORA-B1 FCC/ISED modular approvals.
Manufacturer	Taoglas
Gain	-0.5 dBi
Impedance	50 $\Omega$
Size	30.4 x 30.9 mm
Type	Patch
Connector	U.FL (UMCC), IPEX MHF1
Comment	Should be attached to a plastic enclosure or part for best performance. To be connected to a U.FL connector.



<sup>4</sup> NORA-B12: approvals pending

**FXP72.07.0053A**

Approval<sup>4</sup> FCC, IC, RED, MIC, KCC, ANATEL, RCM, NCC, and ICASA

**2144150011**

Applicable modules NORA-B100, NORA-B101, NORA-B120, NORA-B121  
 For information about how to integrate the U.FL connector with the NORA-B101 **ANT** pin, see also [Antenna reference design](#).  
 It is necessary to follow this reference design to comply with the NORA-B1 FCC/ISED modular approvals.



Manufacturer	Molex
Gain	+5.3 dBi
Impedance	50 Ω
Size	Ø 9.35 x 108.4 mm
Type	Dipole
Connector	Reverse Polarity SMA plug (inner thread and pin receptacle).
Comment	This antenna requires to be mounted on a metal ground plane for best performance. To be mounted on the U.FL to Reverse Polarity SMA adapter cable listed in <a href="#">Error! Reference source not found.</a>
Approval <sup>5</sup>	FCC, IC, RED, MIC, KCC, ANATEL, RCM, NCC, and ICASA (NORA-B100, NORA-B101) FCC, IC (NORA-B120, NORA-B121)

**W1030**

Applicable modules NORA-B120, NORA-B121  
 For information about how to integrate the U.FL connector with the NORA-B121 **ANT** pin, see also [Antenna reference design](#).  
 It is necessary to follow this reference design to comply with the NORA-B1 FCC/ISED modular approvals.



Manufacturer	PulseLarsen Antennas
Gain	+2 dBi
Impedance	50 Ω
Size	Ø 10.0 x 82.5 mm
Type	Dipole
Connector	Reverse Polarity SMA plug (inner thread and pin receptacle)
Comment	This antenna requires to be mounted on a metal ground plane for best performance. To be mounted on the U.FL to Reverse Polarity SMA adapter cable listed in <a href="#">Error! Reference source not found.</a>
Approval <sup>5</sup>	FCC, IC, RED, MIC, KCC, ANATEL, RCM, NCC, and ICASA

<sup>5</sup> NORA-B12: approvals pending

**FXP73.07.0100A**

Applicable modules	NORA-B120, NORA-B121 For information about how to integrate the U.FL connector with the NORA-B121 <b>ANT</b> pin, see also <a href="#">Antenna reference design</a> . It is necessary to follow this reference design to comply with the NORA-B1 FCC/ISED modular approvals.	Oh
Manufacturer	Taoglas Limited	
Gain	+2.5 dBi	
Impedance	50 Ω	
Size	47 x 7 x 0.1 mm	
Type	Flexible patch	
Connector	MHFI (U.FL Compatible)	
Comment	Should be attached to a plastic enclosure or part for best performance. To be connected to a U.FL connector.	
Approval <sup>6</sup>	FCC, IC, RED, MIC, KCC, ANATEL, RCM, NCC, and ICASA	

**WCM.01.0111**

Applicable modules	NORA-B120, NORA-B121 For information about how to integrate the U.FL connector with the NORA-B121 <b>ANT</b> pin, see also <a href="#">Antenna reference design</a> . It is necessary to follow this reference design to comply with the NORA-B1 FCC/ISED modular approvals.	
Manufacturer	Taoglas Limited	
Gain	0.89 dBi	
Impedance	50 Ω	
Size	19.8 x 14.3 x 16.4 mm	
Type	PIFA "Button"	
Connector	Reverse Polarity SMA plug (inner thread and pin receptacle)	
Comment	NORA-B120, NORA-B121 For information about how to integrate the U.FL connector with the NORA-B121 <b>ANT</b> pin, see also <a href="#">Antenna reference design</a> . It is necessary to follow this reference design to comply with the NORA-B1 FCC/ISED modular approvals.	
Approval <sup>6</sup>	FCC, IC, RED, MIC, KCC, ANATEL, RCM, NCC, and ICASA	

<sup>6</sup> NORA-B12: approvals pending

## 9 Technology standards compliance

### 9.1 Bluetooth SIG



The NORA-B1 module series is qualified as a tested component according to the Bluetooth 5.2 specification.

Product type	QDID	Listing date
NORA-B10 RF-PHY Component (Tested)	164871	08-Mar-2021
NORA-B12 RF-PHY Component (Tested)	197315	28-Oct-2022

**Table 22: NORA-B1 series Bluetooth qualified design ID**

The Bluetooth SIG requires the following:

- All manufacturers of products that use Bluetooth technology are required to become members of the Bluetooth SIG.
- All end-products or end-product family that utilize Bluetooth technology must be declared with the Bluetooth SIG.

For details regarding the declaration process, see the Bluetooth qualification process for nRF5 modules, application note [\[7\]](#).

### 9.2 Matter

End-products that incorporate the Matter protocol are required to join the Connectivity Standards Alliance [\[26\]](#) and certify the end-product.

### 9.3 Thread

End-products that incorporate the Thread protocol are required to join the Thread Group [\[24\]](#) and certify the end-product.

### 9.4 Zigbee

End-products that incorporate the Zigbee protocol are required to join the Connectivity Standards Alliance [\[26\]](#) and certify the end-product.

### 9.5 USB

End-products that incorporate USB technology are required to join the USB Integrators Forum (USB-IF) [\[27\]](#) and certify the end-product with the USB.

## 10 Product testing

### 10.1 u-blox in-line production test

As part of our focus on high quality products, u-blox maintain stringent quality controls throughout the production process. This means that all units in our manufacturing facilities are fully tested and that any identified defects are carefully analyzed to improve future production quality.

The Automatic test equipment (ATE) deployed in u-blox production lines logs all production and measurement data – from which a detailed test report for each unit can be generated. [Figure 22](#) shows the ATE typically used during u-blox production.

u-blox in-line production testing includes:

- Digital self-tests (firmware download, MAC address programming)
- Measurement of voltages and currents
- Functional tests (host interface communication)
- Digital I/O tests
- Measurement and calibration of RF characteristics in all supported bands, including RSSI calibration, frequency tuning of reference clock, calibration of transmitter power levels, etc.
- Verification of Wi-Fi and Bluetooth RF characteristics after calibration, like modulation accuracy, power levels, and spectrum, are checked to ensure that all characteristics are within tolerance when the calibration parameters are applied.



**Figure 22: Automatic test equipment for module testing**

## 10.2 OEM manufacturer production test

As all u-blox products undergo thorough in-series production testing prior to delivery, OEM manufacturers do not need to repeat any firmware tests or measurements that might otherwise be necessary to confirm RF performance. Testing over analog and digital interfaces is also unnecessary during an OEM production test.

OEM manufacturer testing should ideally focus on:

- Module assembly on the device; it should be verified that:
  - Soldering and handling process did not damage the module components
  - All module pins are well soldered on application board
  - There are no short circuits between pins
- Component assembly on the device; it should be verified that:
  - Communication with host controller can be established
  - The interfaces between module and device are working
  - Overall RF performance test of the device including antenna

In addition to this testing, OEMs can also perform other dedicated tests to check the device. For example, the measurement of module current consumption in a specified operating state can identify a short circuit if the test result deviates that from that taken against a “Golden Device”.

The standard operational module firmware and test software on the host can be used to perform functional tests (communication with the host controller, check interfaces) and perform basic RF performance testing. Special manufacturing firmware can also be used to perform more advanced RF performance tests.

### 10.2.1 “Go/No go” tests for integrated devices

A “Go/No go” test compares the signal quality with a “Golden Device” in a location with known signal quality. This test can be performed after establishing a connection with an external device.

A very simple test can be performed by just scanning for a known Bluetooth low energy device and checking the signal level. These kinds of test may be useful as a “go/no go” test but not for RF performance measurements. This test is suitable to check the functionality of the communication with the host controller and the power supply. It is also a means to verify if the components are well soldered.

A basic RF functional test of the device including the antenna can be performed with standard Bluetooth low energy devices as remote stations. The device containing the NINA-B3 series module and the antennas should be arranged in a fixed position inside an RF shield box to prevent interferences from other possible radio devices to get stable test results.

# Appendix

## A Glossary

Abbreviation	Definition
AC	Alternating Current
ADC	Analog to Digital Converter
ATE	Automatic Test Equipment
CPU	Central Processing Unit
CTS	Clear To Send signal
DC	Direct Current
DC/DC	DC to DC switching voltage converter
EIRP	Effective Isotropic Radiated Power
ESD	ElectroStatic Discharge
FCC	Federal Communications Commission (USA)
FEM	Front End Module
GND	Ground
GPIO	General Purpose Input / Output
I2C	Inter-Integrated Circuit interface
I2S	Inter-IC Sound interface
ICASA	Independent Communications Authority of South Africa
IDE	Integrated Development Environment
IEEE	Institute of Electrical and Electronics Engineers
ISED	Innovation, Science, and Economic Development (Canada)
ETSI	European Standards Technology Institute
JTAG	Joint Test Action Group
KCC	Korean Communications Commission
KMU	Key Management Unit
LDO	Low Drop-Out voltage regulator
LE	Low Energy
LNA	Low Noise Amplifier
MCU	Microprocessor Unit
MIC	Ministry of Internal Affairs and Commerce (Japan)
MSL	Moisture Sensitivity Level
NCC	National Communications Commission (Taiwan)
NFC	Near-Field Communication
NSMD	Non Solder Mask Defined
OEM	Original Equipment Manufacturer
OTP	One-Time Programmable
OUI	IEEE Organizationally Unique Identifier
PA	Power Amplifier
PCB	Printed Circuit Board
PDM	Pulse Density Modulation
QSPI	Quad Serial Peripheral Interface
R&TTE	Radio and Telecommunications Terminal Equipment (Europe)
RCM	Regulatory Compliance Mark (Australia and New Zealand)



Abbreviation	Definition
RF	Radio Frequency
RP-SMA	Reverse Polarity SubMiniature version A RF connector
RTLS	Real Time Location Service
RTOS	Real Time Operating System
RTS	Request To Send signal
RXD	Receive Data signal
SDK	Software Development Kit
SMA	SubMiniature version A RF connector
SMD	Solder Mask Defined
SMPS	Switching mode power supply (see DC/DC)
SMT	Surface-Mount Technology
SoC	System-on-Chip
SPI	Serial Peripheral Interface
SWD	Serial Wire Debug
THT	Through-Hold Technology
TXD	Transmit Data signal
TWI	See I2C
UART	Universal Asynchronous Receiver / Transmitter
UICR	User Information Configuration Registers
USB	Universal Serial Bus

**Table 23: Explanation of the abbreviations and terms used**

## B Antenna reference designs

Designers can take full advantage of NORA-B1 Single-Modular Transmitter certification approval by integrating the u-blox reference design into their products. This approach requires compliance with the following rules:

- Only [pre-approved antennas](#) can be used.
- Schematics and parts used in the design must be identical to the reference design, please use u-blox-validated parts for antenna matching.
- PCB layout must be identical to the one provided by u-blox. Implement one of the reference designs included in this section or [contact](#) u-blox.
- The designer must use the PCB stack-up provided by u-blox. RF traces on the carrier PCB are part of the certified design.

The [Pre-approved antennas list](#) may be used with the **NORA-B101** and **NORA-B121 ANT** antenna pin and tuning circuitry, as shown in [Figure 23](#) and [Figure 24](#). Do not populate C9 or C12.

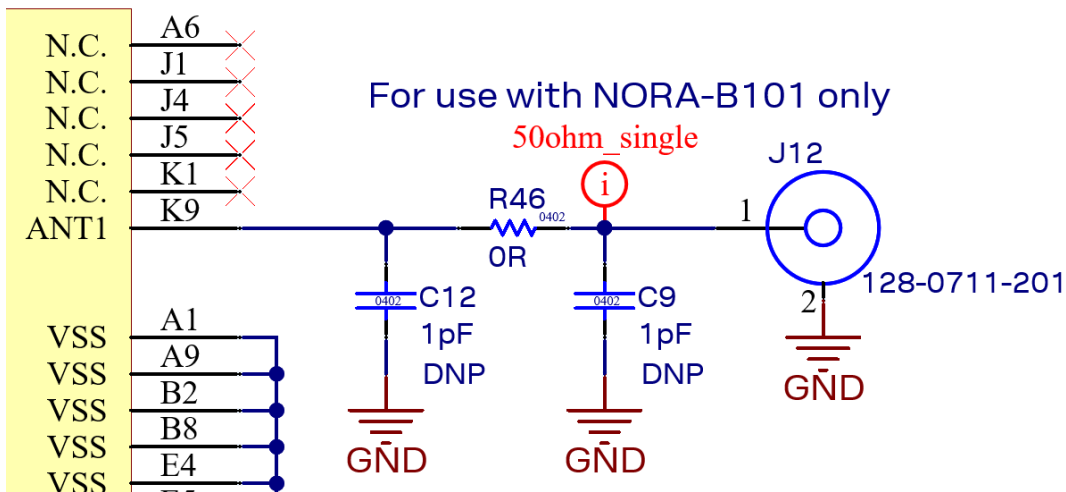

Figure 23: NORA-B101 and NORA-B121 ANT pin U.FL schematic

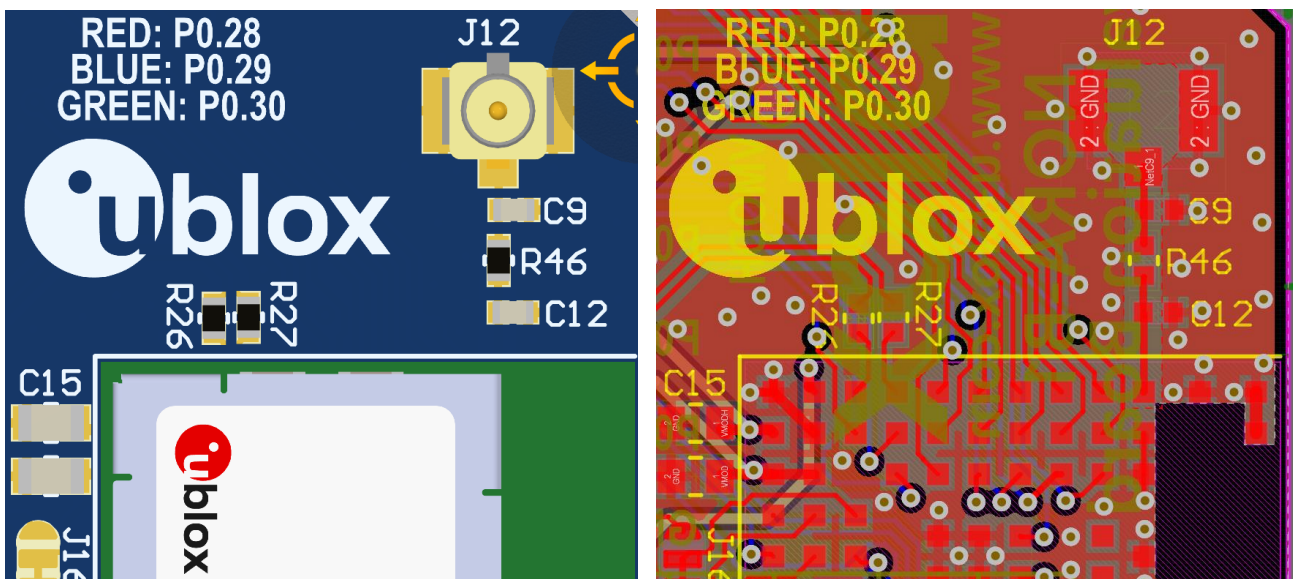

Figure 24: NORA-B101 and NORA-B121 U.FL PCB layout

## Related documents

- [1] NORA-B1 data sheet, [UBX-20027119](#)
- [2] Packaging information guide, [UBX-14001652](#)
- [3] EVK-NORA-B1 user guide, [UBX-20030319](#)
- [4] MINI-NORA-B1 user guide, [UBX-20057806](#)
- [5] u-blox GitHub repository, [u-blox-sho-OpenCPU](#)
- [6] NORA-B1 Declaration of Conformity, TBD
- [7] Bluetooth qualification process for nRF5 modules app note, [UBX-20009220](#)
- [8] Tag-Connect pad connector - <http://www.tag-connect.com/TC2030-CTX>
- [9] JEDEC J-STD-020C - Moisture/Reflow Sensitivity Classification for Non Hermetic Solid State Surface Mount Devices.
- [10] IEC EN 61000-4-2 - Electromagnetic compatibility (EMC) - Part 4-2: Testing and measurement techniques – Electrostatic discharge immunity test
- [11] ETSI EN 301 489-1 - Electromagnetic compatibility and Radio spectrum Matters (ERM); ElectroMagnetic Compatibility (EMC) standard for radio equipment and services; Part 1: Common technical requirements
- [12] IEC61340-5-1 - Protection of electronic devices from electrostatic phenomena – General requirements
- [13] ETSI EN 60950-1:2006 - Information technology equipment – Safety – Part 1: General requirements
- [14] FCC [KDB 447498 RF Exposure](#)
- [15] FCC [KDB 996369 Modular Approval](#)
- [16] JESD51 – Overview of methodology for thermal testing of single semiconductor devices
- [17] Nordic Semiconductor [nRF5340 Product Specification, debug, and trace](#)
- [18] Nordic Semiconductor [nRF Connect for Desktop download](#)
- [19] Nordic Semiconductor [nRF Connect SDK documentation](#)
- [20] Nordic Semiconductor [nRF Connect SDK application development](#)
- [21] Nordic Semiconductor [nRF Connect SDK working with nRF53](#)
- [22] Nordic Semiconductor [DevZone support site](#)
- [23] Nordic Semiconductor [nRF Command Line Tools](#)
- [24] SEGGER [J-Link downloads](#)
- [25] Thread Group [website](#)
- [26] Connectivity Standards Alliance [website](#)
- [27] USB Integrators Forum (USB-IF) [website](#)
- [28] Microsoft Visual Studio [website](#)

For product change notifications and regular updates of u-blox documentation, register on our website, [www.u-blox.com](http://www.u-blox.com).

## Revision history

Revision	Date	Name	Comments
R01	14-Aug-2020	brec	Initial release
R02	04-Feb-2021	brec	Updated for engineering sample, antenna selections, minor edits
R03	19-May-2021	brec	Updated for initial production, added ETSI, FCC, ISED agency approvals
R04	30-Jun-2021	brec	Corrected <a href="#">Bluetooth SIG</a> qualification type. Improved clarity regarding country approvals that are pending
R05	28-Sep-2021	brec	Added NORA-B12 information throughout, added custom hardware and application development sections, rearranged sections for better flow, and updated <a href="#">Handling and soldering</a> information
R06	05-Nov-2021	brec	Added NORA-B10 certification information for Japan (MIC) and South Korea (KCC)
R07	17-Feb-2022	brec	Updated document status for NORA-B12 modules to objective specification, removed IEEE 802.15.4 channel 26 limitation, removed pending from <a href="#">Australia and New Zealand</a> RF declaration for NORA-B10 modules. Updated <a href="#">Product testing</a> , updated <a href="#">Table 8</a> FEM control pin names.
R08	22-Jun-2022	brec	Updated document status for NORA-B12 modules to Advance Information. Corrected <a href="#">Table 4</a> SCK on pad B1 and added certification numbers in <a href="#">NCC</a> and <a href="#">ICASA</a> compliance statements. Updated the <a href="#">pre-approved antennas list</a> with information for the NORA-B12 modules. Updated contact information.
R09	27-Jan-2023	brec	Updated NORA-B12 product status to early production information, added NORA-B12 Bluetooth SIG QDID in <a href="#">Table 22</a> , added tables for certification numbers in <a href="#">section 8</a> , added link to Microsoft Visual Studio, removed outdated development tool references.

## Contact

For further support and contact information, visit us at [www.u-blox.com/support](http://www.u-blox.com/support).