



<b>RADIO REPORT</b> <b>FCC 47 CFR Part 15C</b> <b>ISED Canada RSS-247</b> <b>Frequency hopping systems operating within the 2400.0 MHz - 2483.5 MHz MHz band</b>	
<b>Report Reference No</b>	G0M-2405-2583-TFC247BT-V02
<b>Testing Laboratory</b>	Eurofins Product Service GmbH
<b>Address</b>	Storkower Str. 38c 15526 Reichenwalde Germany
<b>Accreditation</b>	 <p>DAkkS - Registration number : D-PL-12092-01-03 (ISED)                      ISED Testing Laboratory site: 3470A                      DAkkS - Registration number : D-PL-12092-01-04 (FCC)                      FCC Filed Test Laboratory, Reg.-No.: 96970</p>
<b>Applicant</b>	u-blox AG
<b>Address</b>	Zürcherstrasse 68 8800 Thalwil Switzerland
<b>Test Specification</b>	47 CFR Part 15C RSS-247, Issue 3, 2023-08 RSS-Gen, Issue 5, Amendment 2, 2021-02
<b>Non-Standard Test Method</b>	None
<b>Equipment under Test (EUT):</b>	
<b>Product Description</b>	M.2 card for the MAYA-W2 Wi-Fi 6, Bluetooth 5.3 and IEEE 802.15.4 module
<b>Model(s)</b>	M2-MAYA-W271-00C
<b>Additional Model(s)</b>	None
<b>Brand Name(s)</b>	None
<b>Hardware Version(s)</b>	05
<b>Software Version(s)</b>	01
<b>FCC ID</b>	XPYMAYAW2A
<b>IC</b>	8595A-MAYAW2A
<b>Test Result</b>	<b>PASSED</b>

Possible test case verdicts:		
Required by standard but not tested	N/T	
Not required by standard	N/R	
Not applicable to EUT	N/A	
Test object does meet the requirement	P(PASS)	
Test object does not meet the requirement	F(FAIL)	
Testing:		
Test Lab Temperature	20 °C - 30 °C	
Test Lab Humidity	25 % - 55 %	
Date of receipt of test item	2024-06-24	
Report:		
Compiled by	Azamat Ibraimov	
Tested by (+ signature) (Responsible for Test)	Azamat Ibraimov	 .....
Approved by (+ signature) (Test Lab Engineer)	Wilfried Treffke	 .....
Date of Issue	2024-09-10	
Total number of pages	33	
General Remarks:		
<p><b>The test results presented in this report relate only to the object tested.</b></p> <p><b>The results contained in this report reflect the results for this particular model and serial number. It is the responsibility of the manufacturer to ensure that all production models meet the intent of the requirements detailed within this report.</b></p> <p>This report shall not be reproduced, except in full, without the written approval of the Issuing testing laboratory.</p>		
Additional Comments:		
None		

**VERSION HISTORY**

Version History			
Version	Issue Date	Remarks	Revised By
01	2024-08-02	Initial Release	--
02	2024-09-10	Replaced document: G0M-2405-2583-TFC247BT-V01 Replaced by: G0M-2405-2583-TFC247BT-V02  Changes: <ul style="list-style-type: none"> <li>• Update and correction of Support Equipment table</li> </ul>	St. Liebich

**ABBREVIATIONS AND ACRONYMS**

Acronyms	
Acronym	Description
BR	Basic Rate (Bluetooth)
EUT	Equipment Under Test
FCC	Federal Communications Commission
ISED	Innovation, Science and Economic Development Canada
RBW	Resolution bandwidth
RMS	Root mean square
VBW	Video bandwidth
V <sub>NOM</sub>	Nominal supply voltage

**REPORT INDEX**

<b>1</b>	<b>Equipment (Test Item) Under Test.....</b>	<b>6</b>
1.1	Photos.....	7
1.2	Test Modes.....	13
1.3	Test Frequencies.....	14
1.4	Sample emission level calculation.....	15
<b>2</b>	<b>Result Summary.....</b>	<b>16</b>
<b>3</b>	<b>Test Conditions and Results.....</b>	<b>17</b>
3.1	Test Conditions and Results - Transmitter radiated emissions.....	17
3.2	Test Conditions and Results - Receiver radiated emissions.....	22
ANNEX A	Transmitter spurious emissions.....	26
ANNEX B	Receiver spurious emissions.....	31

## 1 Equipment (Test Item) Under Test

Description	M.2 card for the MAYA-W2 Wi-Fi 6, Bluetooth 5.3 and IEEE 802.15.4 module		
Model	M2-MAYA-W271-00C		
Additional Model(s)	None		
Brand Name(s)	None		
Sample Identification	EUT #	Sample-ID	Serial Number
	EUT 1	49021	HW5_26
Hardware Version(s)	05		
Software Version(s)	01		
PMN	M2-MAYA-W271		
HVIN	MAYA-W271-00B		
FVIN	N/A		
HMN	N/A		
FCC ID	XPYMAW2A		
IC	8595A-MAYAW2A		
Equipment type	Radio Module		
Radio type	Transceiver		
Assigned frequency bands	2400.0 MHz - 2483.5 MHz		
Radio technology	Bluetooth		
Modulation	GFSK, PI/4-DQPSK, 8-DPSK		
Number of antenna ports	2 (only one port is active for Bluetooth)		
Radio Module	Type	WLAN 2.4/5 GHz / Bluetooth / ZigBee module	
	Model	M2-MAYA-W271-00C	
	Manufacturer	u-blox AG	
	HW Version	05	
	SW Version	01	
Antenna	Type	External antenna	
	Model	ANT-DB1-RAF-SMA	
	Manufacturer	TE/Linx Technologies	
	Gain	+ 4.1 dBi	
Supply Voltage	$V_{NOM}$	3.3 V DC	
Operating Temperature	$T_{NOM}$	20°C	
Dedicated AC/DC-Adaptor	None		
Manufacturer	u-blox AG Zürcherstrasse 68 8800 Thalwil Switzerland		

1.1 Photos

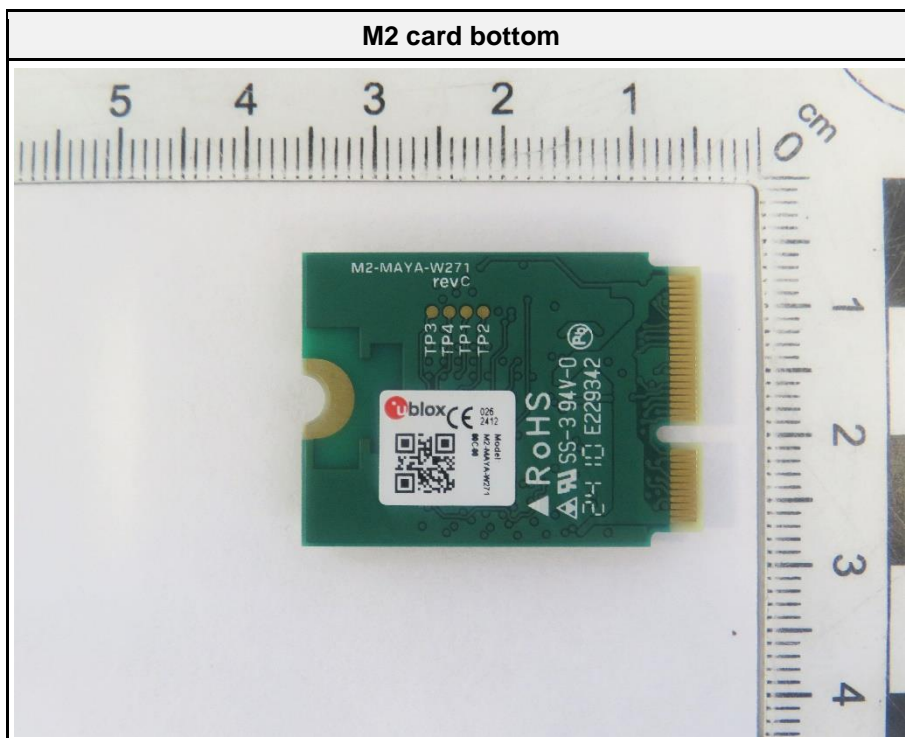
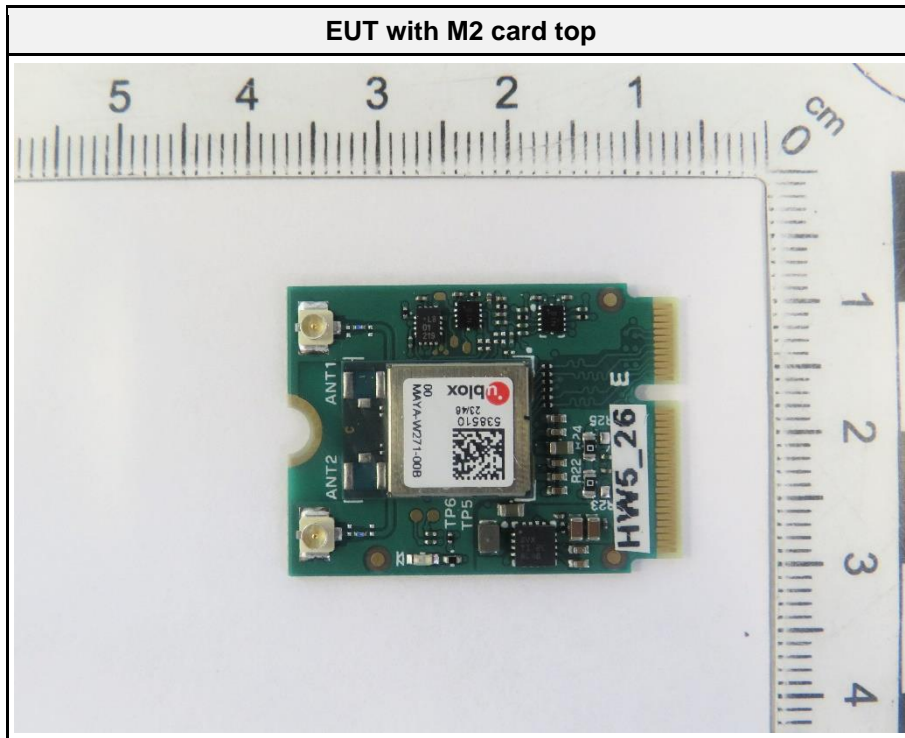

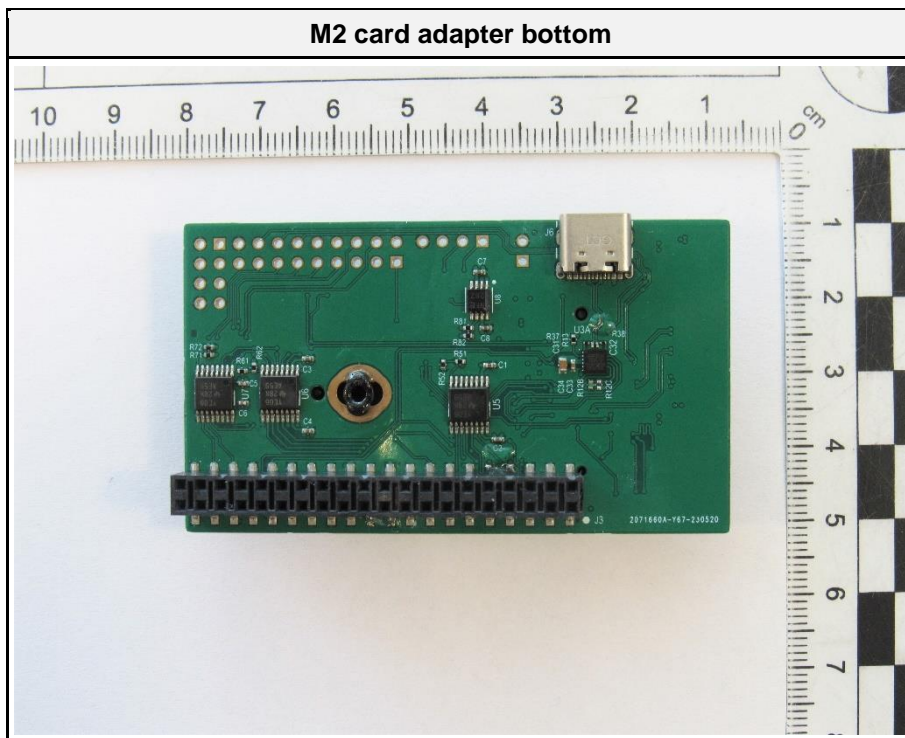
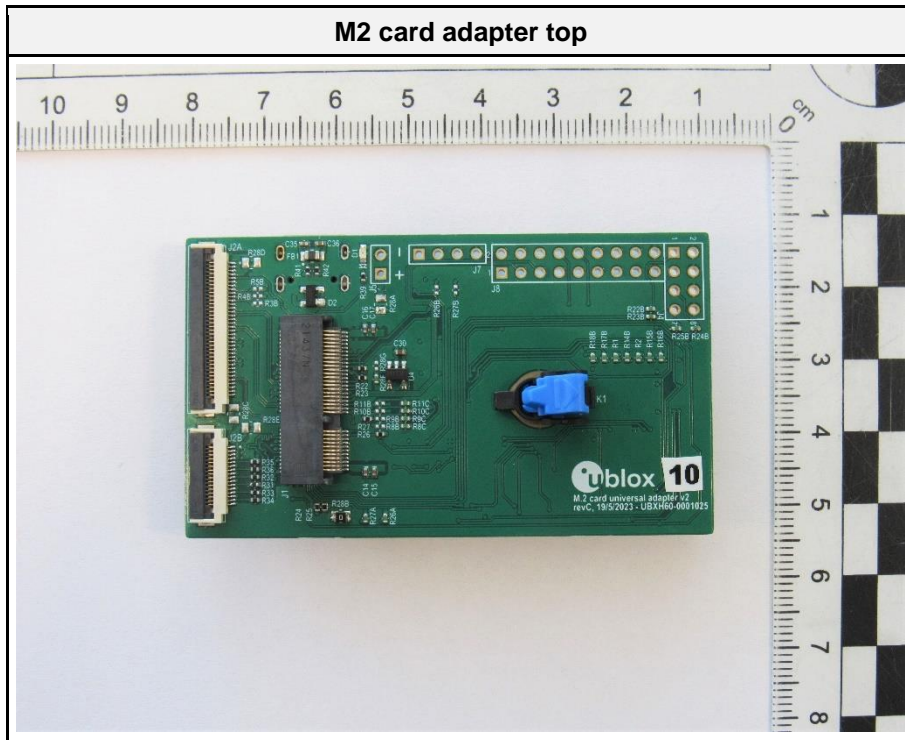



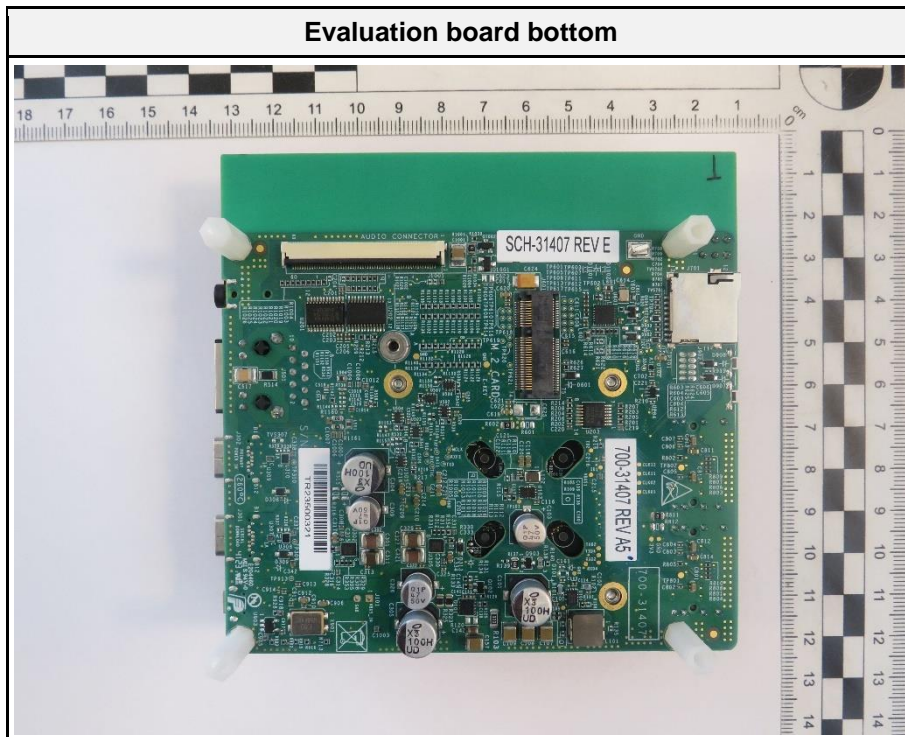
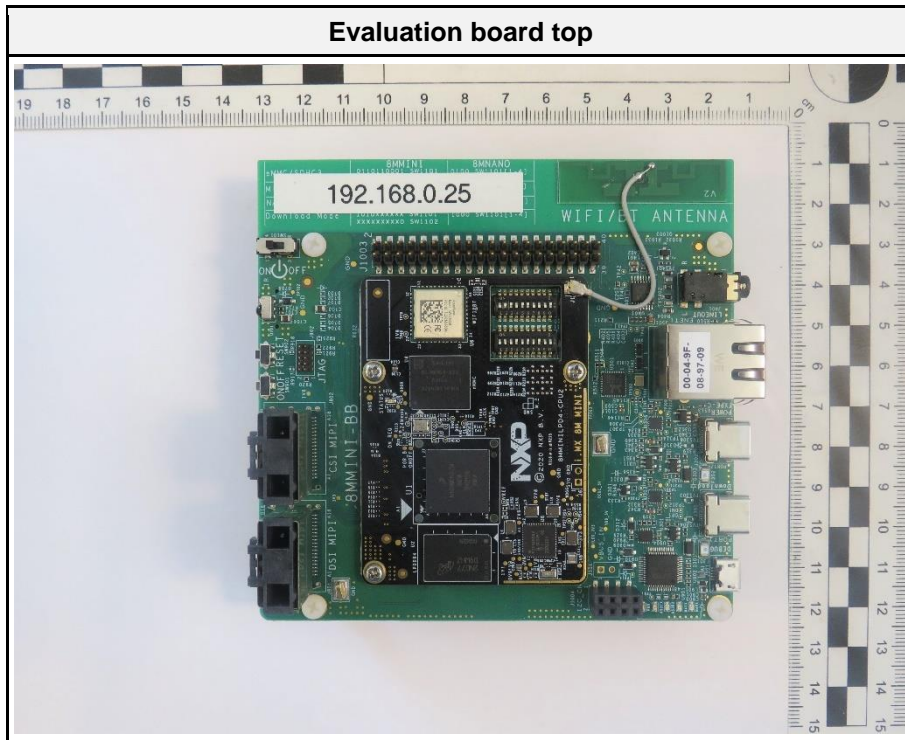

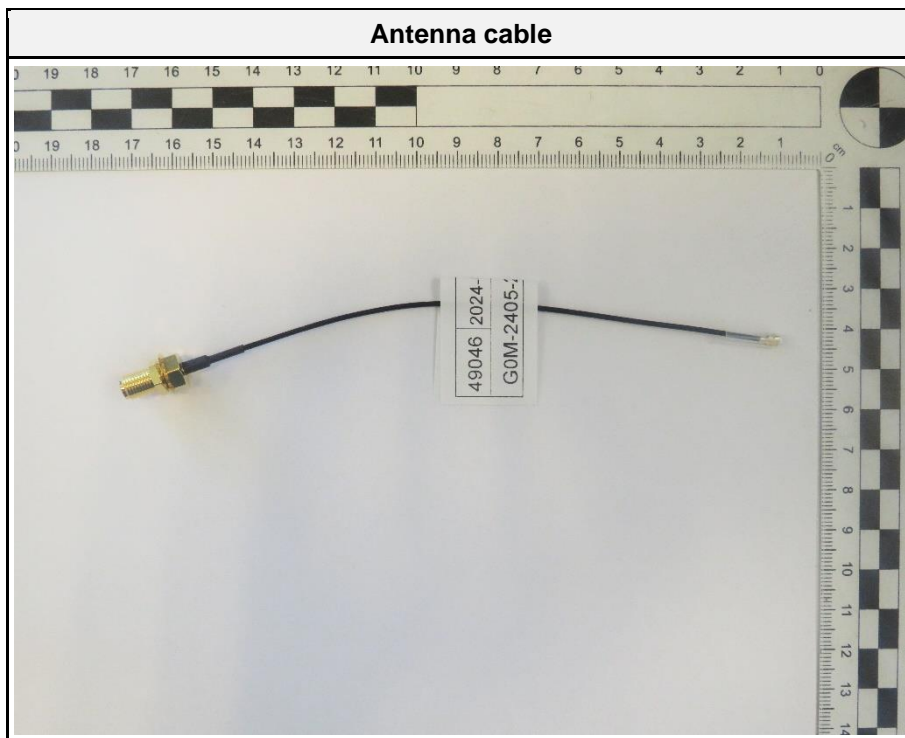
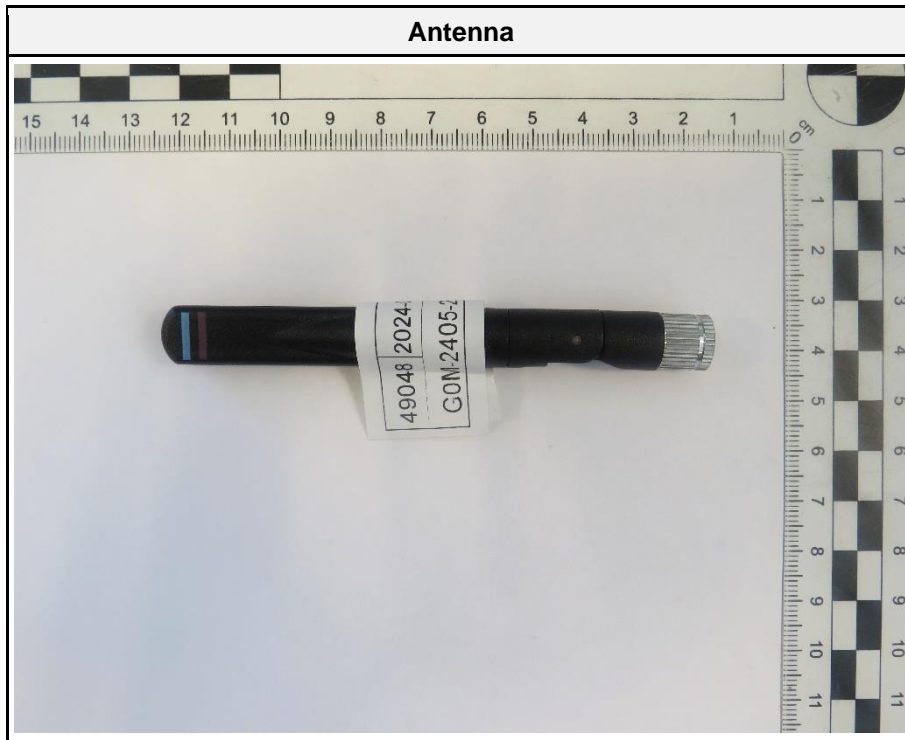

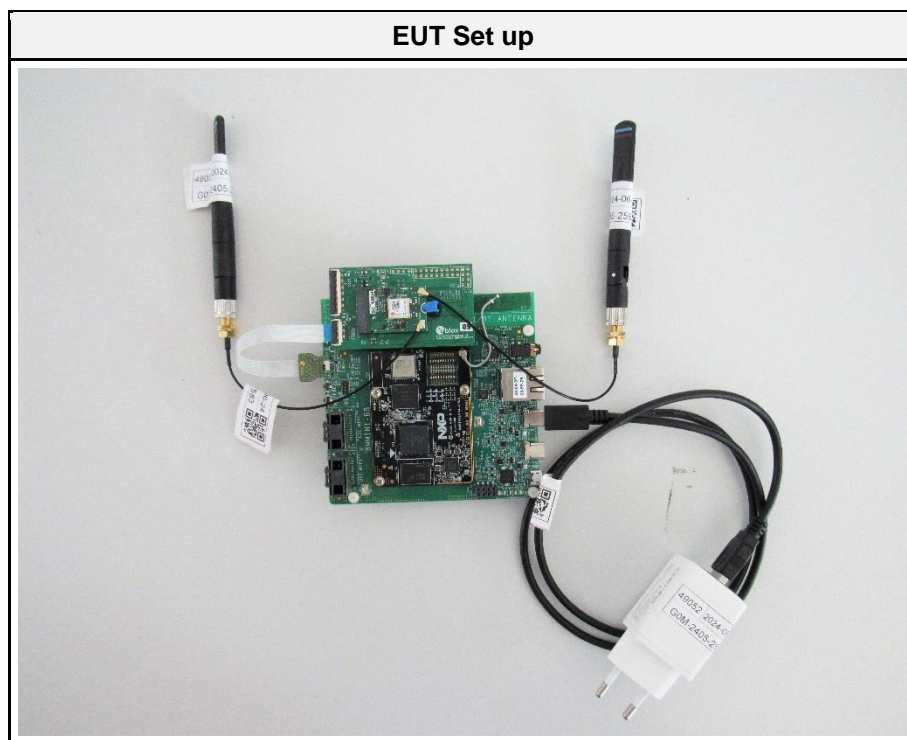
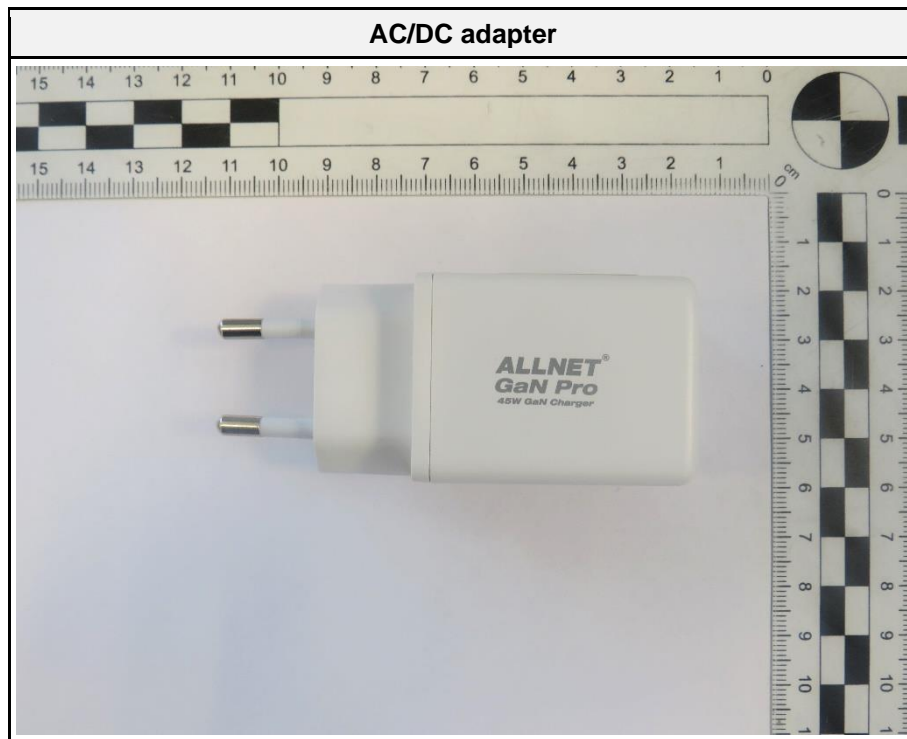

## Support Equipment

Product Type	Device	Manufacturer	Model	Comment
AE	Laptop	Lenovo	--	For configuring test mode
AE	Evaluation Kit for the i.MX 8M Mini Applications Processor	NXP	8MMINILPD4-EVK	Host computer board
AE	M2 card adapter	u-blox	v2 revC	--
AE	AC/DC adapter	Allnet	212154	For evaluation board
CBL	Data cable	Molex	15266-0171	From M2 card adapter to Evaluation Kit for the i.MX 8M Mini Applications Processor, length is 153 mm
CBL	USB-C	--	--	--
SFT	Terminal	--	--	Test mode activation
SIM	Communication Tester	R&S	CMW270	--
Description:				
AE	Auxiliary Equipment			
SIM	Simulator			
CBL	Connecting Cable			
SFT	Software			
Comment: --				

## 1.2 Test Modes

Mode	Description
DH5 Single	Mode = Transmit Modulation = GFSK Spreading = None Packet type = DH5 Duty cycle = 78%
Receive	Mode = Receive (Scan)
Comment: The above settings are found as worst case during evaluation of the original modular test report No.: G0M-2302-1881-TFC247BT-W271-V03, issued on 2024-01-11 by Eurofins Product Service GmbH.	

### 1.3 Test Frequencies

Designator	Mode	Channel	Frequency [MHz]
F1	Tx / Rx	0	2402

### 1.4 Sample emission level calculation

The following is a description of terms and a sample calculation, as appears in the radiated emissions data table. The numbers used in the calculation are for example only. There is no direct correlation to the specific data taken for the product described in this document:

Reading:

This is the reading obtained on the spectrum analyzer in dBμV. Any external preamplifiers used are taken into account through internal analyzer settings.

A.F.:

This is the antenna factor for the receiving antenna. It is a conversion factor, which converts electric fields strengths to voltages, which can be measured directly on the spectrum analyzer. It is treated as a loss in dB. Cable losses have been included with the A.F. to simplify the calculations. The antenna factor is used in calculations as follows:

$$\text{Reading on Analyzer (dB}\mu\text{V)} + \text{A.F. (dB/m)} = \text{Net field strength (dB}\mu\text{V/m)}$$

Net:

This is the net field strength measurement (as shown above).

Margin:

This is the margin of compliance below the FCC limit. The units are given in dB. A negative margin indicates the emission was below the limit. A positive margin indicates that the emission exceeds the limit.

Field strength limit:

This is the FCC Class B radiated emission limit (in units of dBμV/m). The FCC limits are given in units of μV/m. The following formula is used to convert the units of μV/m to dBμV/m:

$$\text{Field strength limit (dB}\mu\text{V/m)} = 20 \cdot \log (\mu\text{V/m})$$

Example only for radiated field strength:

Reading + AF	=	Net Reading	:	Net reading	-	Field strength limit	=	Margin
+21.5 dBμV		+ 26 dB/m	:	47.5 dBμV/m		- 57.0 dBμV/m		= -9.5

## 2 Result Summary

FCC 47 CFR Part 15C, ISED RSS-247				
Product Standard Reference	Requirement	Reference Method	Result	Remarks
ISED RSS-Gen, Issue 5 A2 (section 6.7)	Occupied Bandwidth	ANSI C63.10-2013	N/R	Informational only
FCC § 15.247(a)(1) ISED RSS-247 § 5.1 Issue 3	20 dB Bandwidth	ANSI C63.10-2013	N/T	1
FCC § 15.247(a)(1)(iii) ISED RSS-247, Issue 3 (section 5.1)	Number of hopping frequencies	ANSI C63.10-2013	N/T	1
FCC § 15.247(a)(1) ISED RSS-247, Issue 3 (section 5.1)	Frequency hopping channel separation	ANSI C63.10-2013	N/T	1
FCC § 15.247(a)(1)(iii) ISED RSS-247, Issue 3 (section 5.1)	Time of occupancy (Dwell time)	ANSI C63.10-2013	N/T	1
FCC § 15.247(b) ISED RSS-247, Issue 3 (section 5.4)	Maximum peak conducted power	ANSI C63.10-2013	N/T	1
FCC § 15.207 ISED RSS-247, Issue 3 (section 3.1)	AC power line conducted emissions	ANSI C63.10-2013	N/T	1
FCC § 15.247(d) ISED RSS-247, Issue 3 (section 5.5)	Band edge compliance	ANSI C63.10-2013	N/T	1
FCC § 15.247(d) ISED RSS-247, Issue 3 (section 5.5)	Conducted spurious emissions	ANSI C63.10-2013	N/T	1
FCC § 15.247(d) FCC § 15.209 ISED RSS-Gen, Issue 5 A2 (section 6.13)	Transmitter radiated spurious emissions	ANSI C63.10-2013	PASS	--
ISED RSS-247, Issue 3 (section 3.1)	Receiver radiated spurious emissions	ANSI C63.4-2014	PASS	--
Note 1: Permissive change of a certified module.				
Comment: The Decision Rule is applied on the basis of ETSI TR 102 273 and ETSI TR 100 028. These standards provide guidance on how to calculate and apply measurement uncertainty whilst providing maximum uncertainties allowance. In all cases due consideration will be given to ILAC-G8:09/2019. Where a result is considered conditional in respect of its proximity to the limit line, the customer would be made aware of situation so that they can make an informed decision on how to proceed.				

Possible Test Case Verdicts	
PASS	Test object does meet the requirements
FAIL	Test object does not meet the requirements
N/T	Required by standard but not tested
N/R	Not required by standard for the test object



### 3 Test Conditions and Results

#### 3.1 Test Conditions and Results - Transmitter radiated emissions

##### 3.1.1 Information

Test Information	
Reference	FCC § 15.247(d); FCC § 15.209; ISSED RSS-Gen, Issue 5 A2 (section 6.13)
Measurement Uncertainty	± 5.95 dB
Measurement Method	ANSI C63.10 6.4, 6.5, 6.6
Operator	Azamat Ibraimov
Date	2024-07-17 - 2024-07-23

##### 3.1.2 Limits

Limits			
Frequency range [MHz]	Detector	Field strength [ $\mu\text{V}/\text{m}$ ]	Measurement distance [m]
0.009 - 0.09	Average	2400/F[kHz]	300
0.09 - 0.110	Quasi-Peak	2400/F[kHz]	300
0.110 - 0.490	Average	2400/F[kHz]	300
0.490 - 1.705	Quasi-Peak	24000/F[kHz]	30
1.705 - 30.0	Quasi-Peak	30	30
30 - 88	Quasi-Peak	100	3
88 - 216	Quasi-Peak	150	3
216 - 960	Quasi-Peak	200	3
960 - 1000	Quasi-Peak	500	3
>1000	Average	500	3

##### 3.1.3 Setup

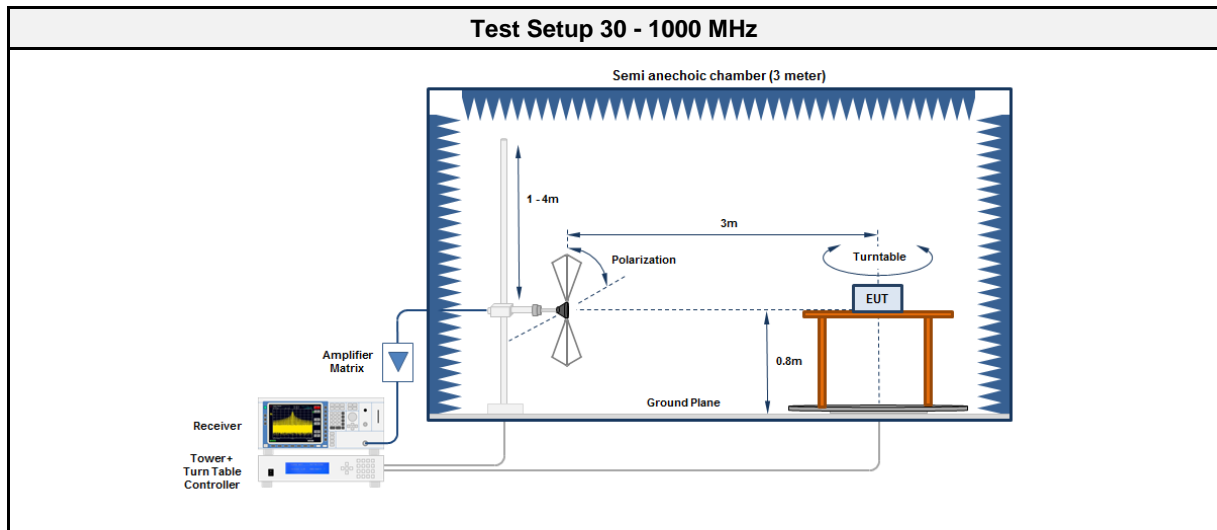

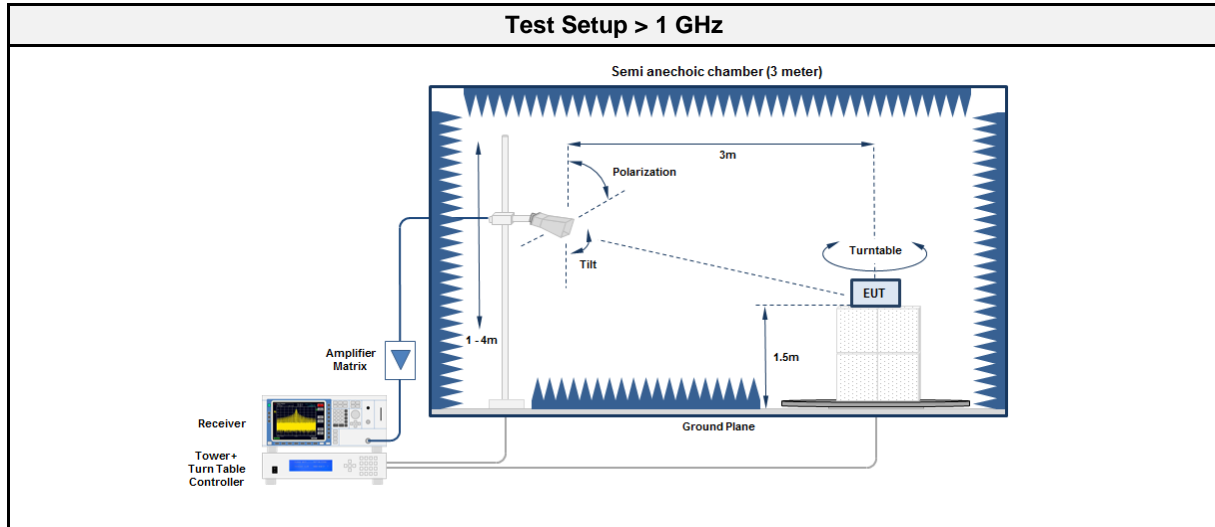

### 3.1.4 Equipment

Test Software			
Description	Manufacturer	Name	Version
EMC Software	DARE Instruments	RadiMation	2023.2.6

Test Equipment 30 - 1000 MHz					
Description	Manufacturer	Model	Identifier	Cal. Date	Cal. Due
Anechoic Chamber	Frankonia	AC1	EF00062	2022-11	2025-11
Test Receiver	Rohde & Schwarz	ESW44	EF01856	2024-04	2025-04
Antenna	Schwarzbeck	VULB 9168	EF01824	2022-10	2025-10

Test Equipment > 1 GHz					
Description	Manufacturer	Model	Identifier	Cal. Date	Cal. Due
Anechoic Chamber	Frankonia	AC2	EF01616	2023-12	2024-12
Spectrum analyzer	Rohde & Schwarz	FSW43	EF00896	2023-08	2024-08
Horn antenna	Schwarzbeck	BBHA 9120B (1-10GHz)	EF01678	2024-05	2027-05
Double Ridged Waveguide Horn Antenna	Schwarzbeck	HWRD 650 (6,5-18GHz)	EF01679	2024-05	2027-05

3.1.5 Procedure

<b>Test Procedure 30 MHz - 1000 MHz</b>
<ol style="list-style-type: none"> <li>1. EUT is placed on a non conducting support at the center of a turn table 0.8 m above the ground</li> <li>2. EUT set to test mode</li> <li>3. The receiver is set to peak detection with max hold</li> <li>4. The EUT is rotated through 360° and the height of the antenna is varied from 1 m to 4 m</li> <li>5. All significant emissions are measured again using the corresponding final detector</li> </ol>

<b>Test Procedure &gt; 1 GHz</b>
<ol style="list-style-type: none"> <li>1. EUT is placed on a non conducting support at the center of a turn table 1.5 m above the ground</li> <li>2. EUT set to test mode</li> <li>3. The receiver is set to peak detection with max hold</li> <li>4. The EUT is rotated through 360° and the height of the antenna is varied from 1 m to 4 m</li> <li>5. All significant emissions are measured again using the corresponding final detector</li> </ol>

3.1.6 Results

<b>Test Results</b>						
Channel [MHz]	Emission [MHz]	Level [dBµV/m]	Det.	Pol.	Limit [dBµV/m]	Margin [dB]
2402	73.65	28.8	pk	ver	40	-11.2
2402	163.2133	27.9	pk	ver	43.5	-15.58
2402	2261.9967	47.96	pk	ver	74	-26.04
2402	2261.9967	40.34	avg	ver	54	-13.66
2402	2361.99	56.51	pk	ver	74	-17.49
2402	2361.99	45.6	avg	ver	54	-8.4
2402	2492.6496	42.25	pk	ver	74	-31.75
2402	2492.6496	33.92	avg	ver	54	-20.08
2402	4804.1333	51.08	pk	ver	74	-22.92
2402	4804.1333	49.08	avg	ver	54	-4.92
2402	12399.333	43.38	pk	ver	74	-30.62
2402	12399.333	38.43	avg	ver	54	-15.57
2480	2484.1237	53.4	pk	ver	74	-20.6
2480	2484.1237	46.05	avg	ver	54	-7.95

3.1.7 Setup Photos

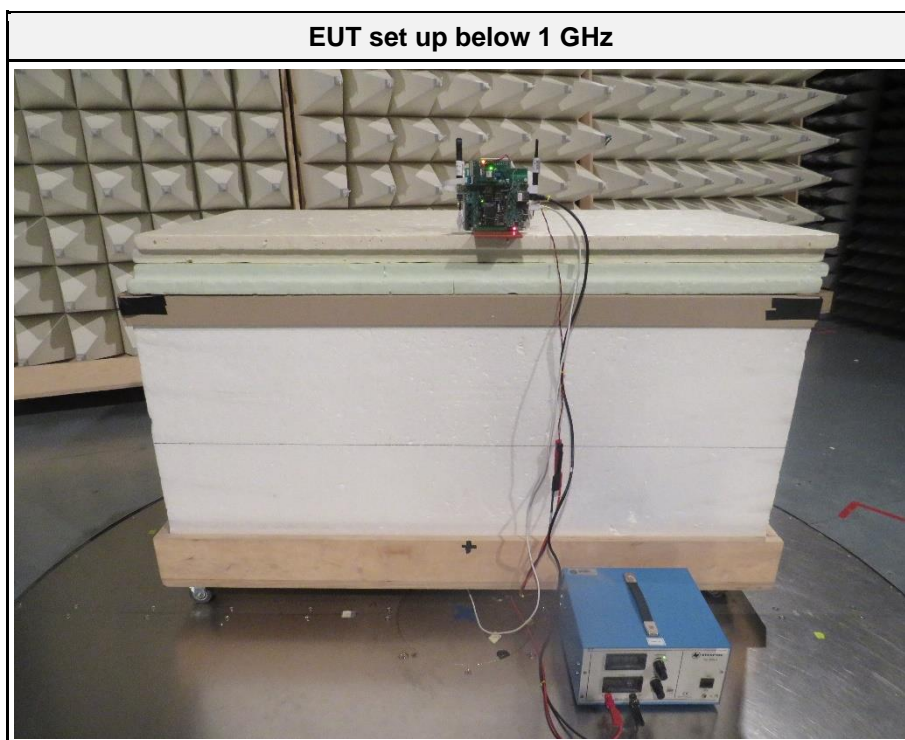
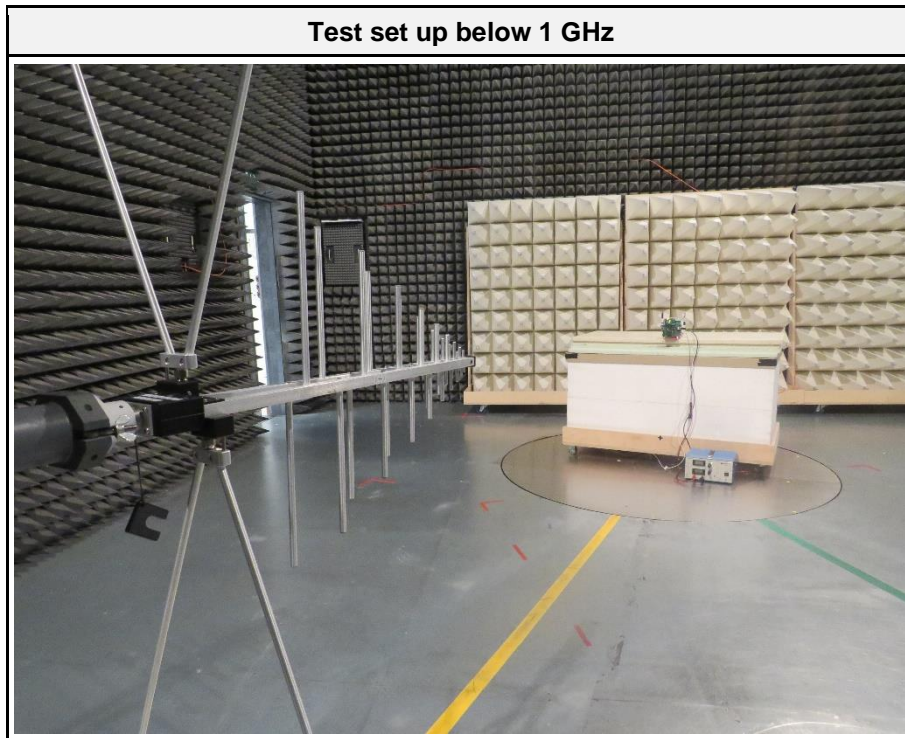

**Test set up above 1 GHz**

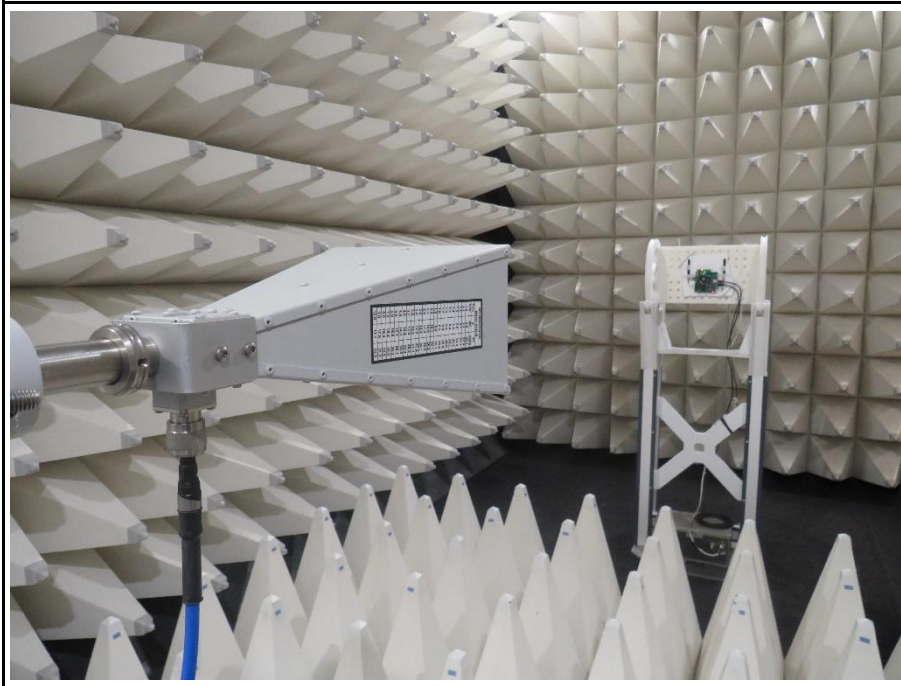

**EUT set up above 1 GHz**

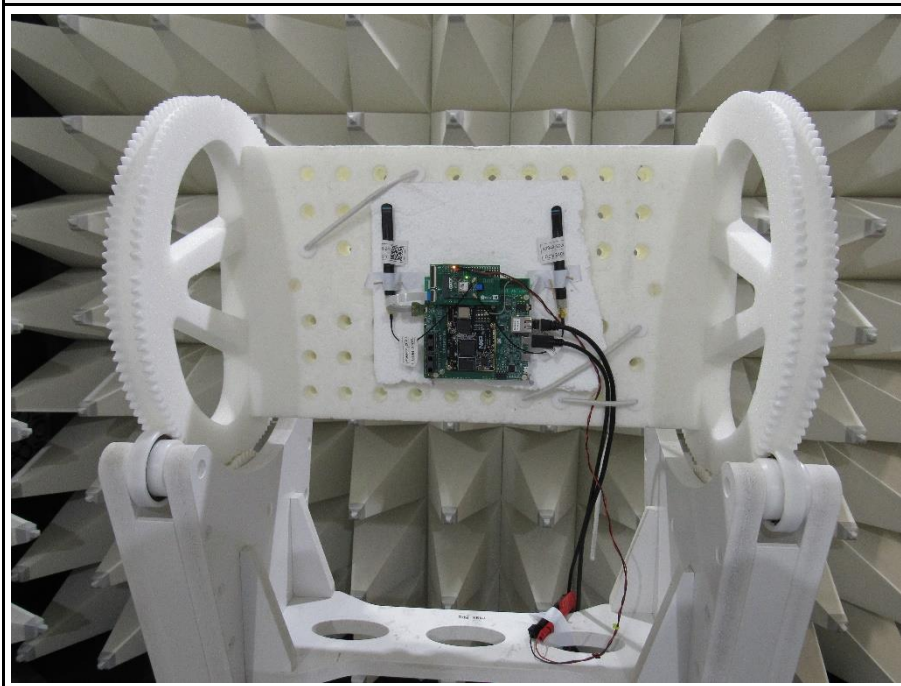

### 3.2 Test Conditions and Results - Receiver radiated emissions

#### 3.2.1 Information

Test Information	
Reference	ISED RSS-247, Issue 3 (section 3.1)
Measurement Uncertainty	± 5.95 dB
Measurement Method	ANSI C63.4-2014 8.1-8.3
Operator	Azamat Ibraimov
Date	2024-07-19 - 2024-07-23

#### 3.2.2 Limits

Limits			
Frequency range [MHz]	Detector	Field strength [ $\mu\text{V}/\text{m}$ ]	Measurement distance [m]
30 - 88	Quasi-Peak	100	3
88 - 216	Quasi-Peak	150	3
216 - 960	Quasi-Peak	200	3
960 - 1000	Quasi-Peak	500	3
>1000	Average	500	3

#### 3.2.3 Setup

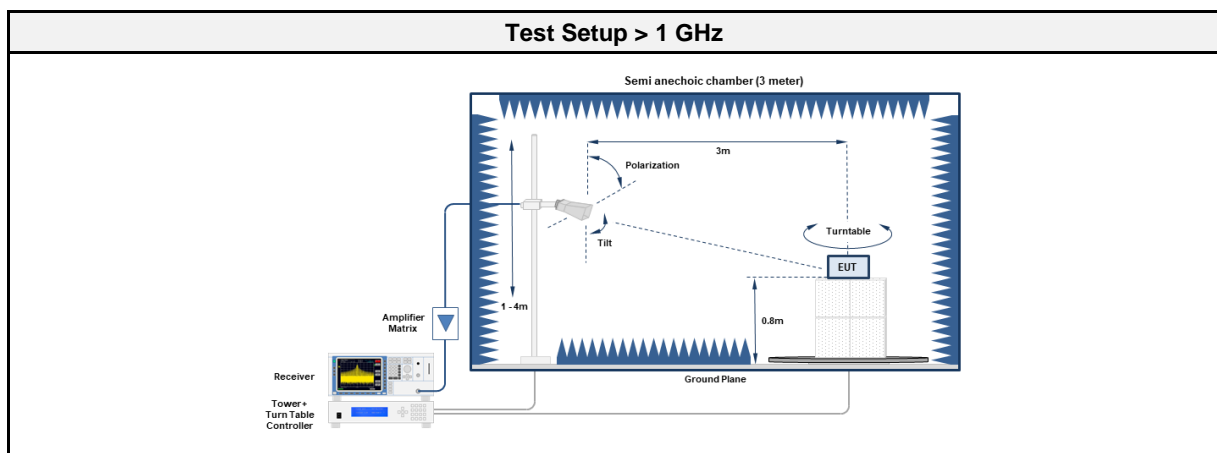
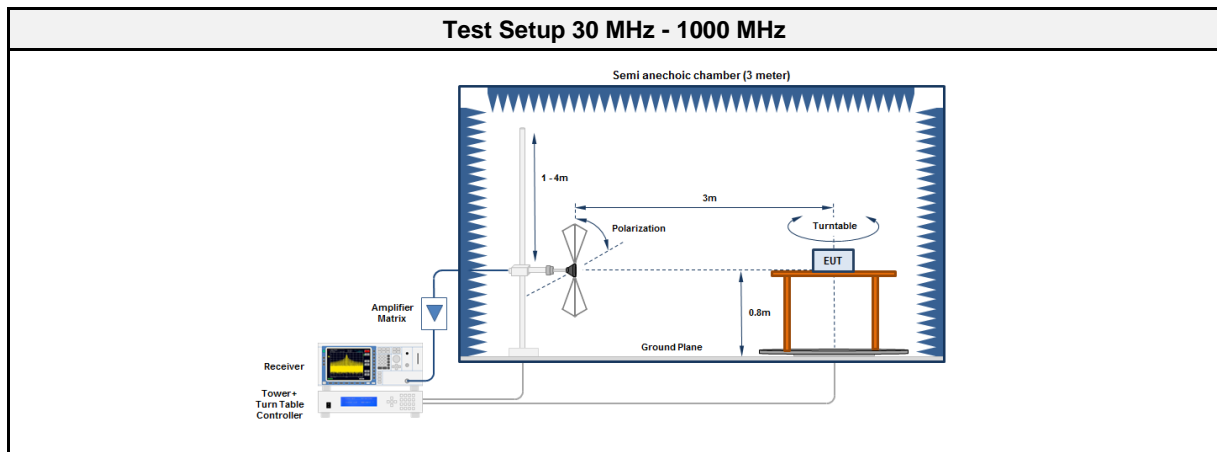

## 3.2.4 Equipment

Test Software			
Description	Manufacturer	Name	Version
EMC Software	DARE Instruments	RadiMation	2023.2.6

Test Equipment 30 MHz - 1000 MHz					
Description	Manufacturer	Model	Identifier	Cal. Date	Cal. Due
Anechoic Chamber	Frankonia	AC1	EF00062	2022-11	2025-11
Test Receiver	Rohde & Schwarz	ESW44	EF01856	2024-04	2025-04
Trilog Broadband Antenna	Schwarzbeck	VULB 9168	EF01824	2022-10	2025-10

Test Equipment > 1 GHz					
Description	Manufacturer	Model	Identifier	Cal. Date	Cal. Due
Anechoic Chamber	Frankonia	AC1	EF01011	2022-11	2023-11
Test Receiver	Rohde & Schwarz	ESW44	EF01856	2024-04	2025-04
Horn antenna	Schwarzbeck	BBHA 9120D	EF01561	2021-11	2024-11
Double Ridged Waveguide Horn Antenna	Schwarzbeck	HWRD 650 (6,5-18GHz)	EF01679	2024-05	2027-05

## 3.2.5 Procedure

Test Procedure
<ol style="list-style-type: none"> <li>1. EUT is placed on a non conducting support at the center of a turn table 0.8 m above the ground</li> <li>2. EUT is set to test mode</li> <li>3. The receiver is set to peak detection with max hold</li> <li>4. The EUT is rotated through 360° and the height of the antenna is varied from 1 m to 4 m</li> <li>5. All significant emissions are measured again using the corresponding final detector</li> </ol>

## 3.2.6 Results

Test Results						
Channel [MHz]	Emission [MHz]	Level [dB $\mu$ V/m]	Det.	Pol.	Limit [dB $\mu$ V/m]	Margin [dB]
Scan mode	31.94	28.3	pk	ver	40	-11.74
Scan mode	72.68	29.6	pk	ver	40	-10.37
Scan mode	95.96	29.8	pk	ver	43.5	-13.65

3.2.7 Setup Photos

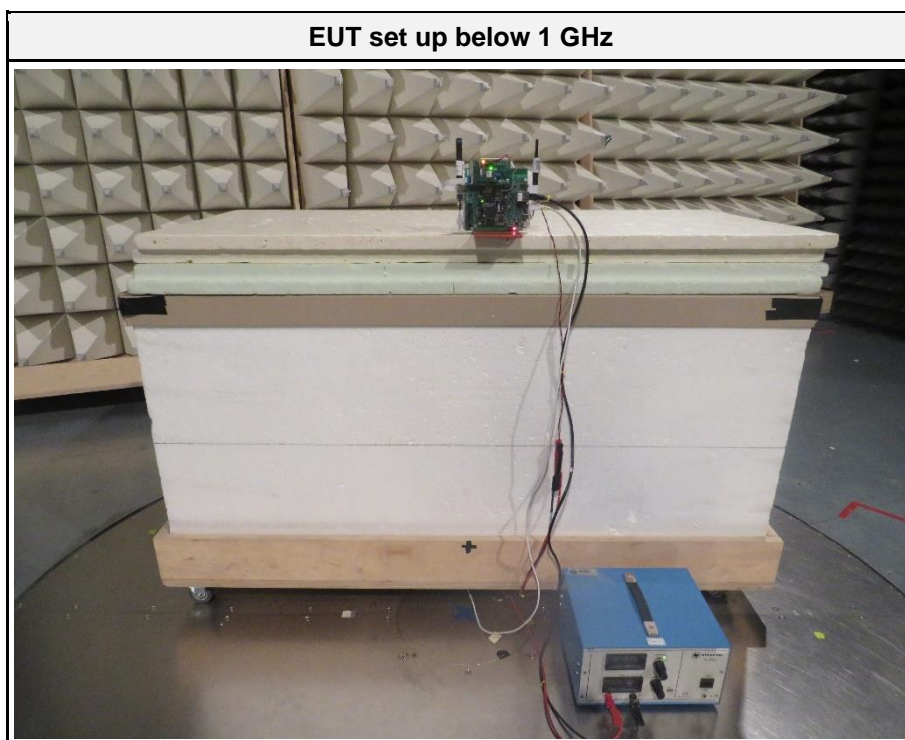
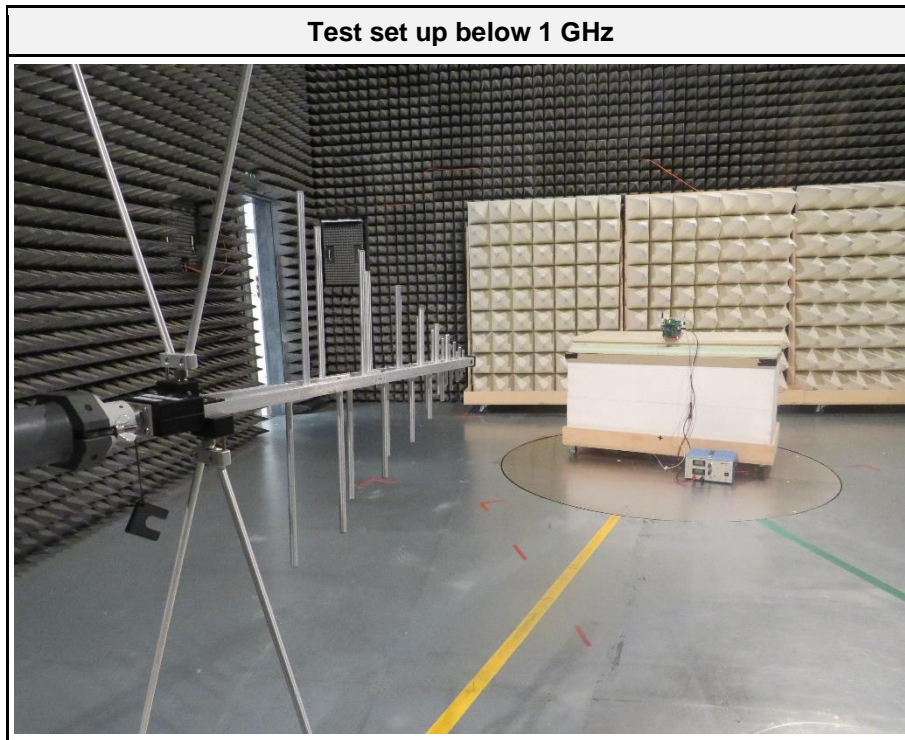



Test set up above 1 GHz

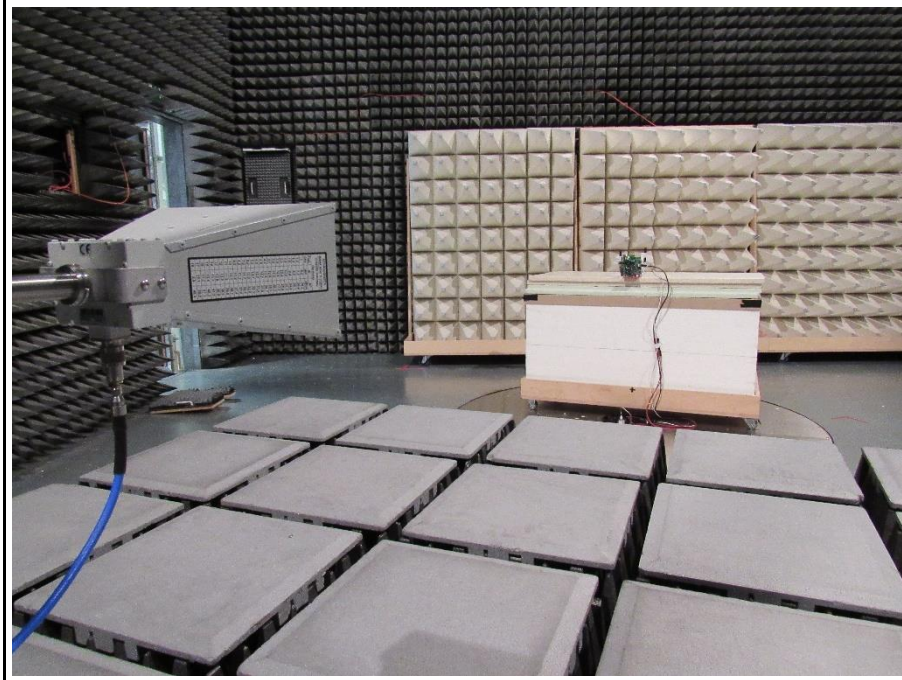

## ANNEX A Transmitter spurious emissions

### Radiated Spurious Emissions according to 47 CFR Part 15.247, RSS-Gen Issue 5

Project Number: G0M-2405-2583  
 Applicant: u-blox AG  
 Model Description: M.2 card for the MAYA-W2 Wi-Fi 6, Bluetooth 5.3 and IEEE 802.15.4 module  
 Model: M2-MAYA-W271-00C  
 Test Sample ID: 49021  
 Test Site: Eurofins Product Service GmbH  
 Operator: Mr. Ibraimov  
 Measurement software: RadiMation, version 2023.2.6  
 Test Conditions: Tnom: 22 °Celsius, Vnom: 3.3 VDC  
 Antenna: Schwarzbeck VULB 9168  
 Measurement distance: 3 m  
 Mode: Tx; BT\_BR\_2402 MHz  
 Test Date: 2024-07-23

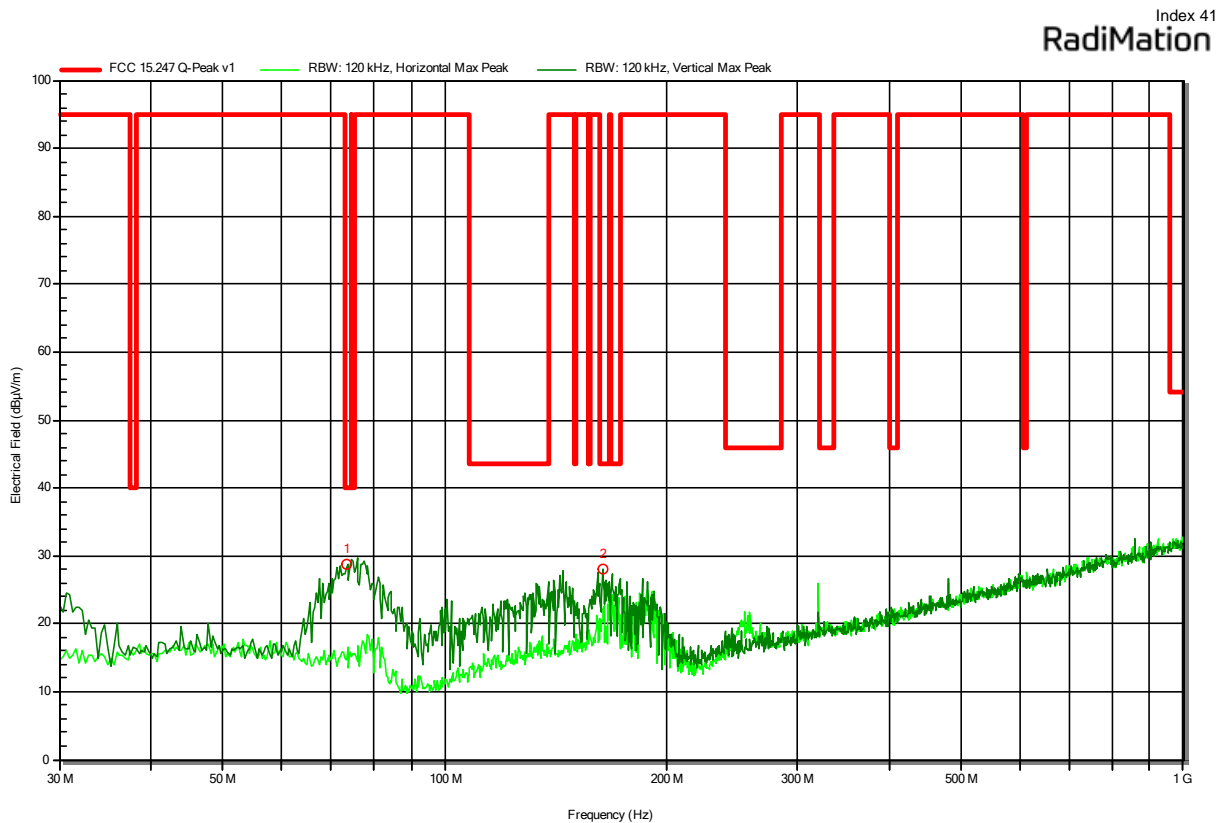

Peak Number	Frequency (MHz)	Peak (dBµV/m)	Peak Limit (dBµV/m)	Peak Difference (dB)	Peak Status	Polarization
1	73.65	28.8	40	-11.2	Pass	Vertical
2	163.2133	27.9	43.5	-15.58	Pass	Vertical

### Radiated Spurious Emissions according to 47 CFR Part 15.247, RSS-Gen Issue 5

Project Number: G0M-2405-2583  
 Applicant: u-blox AG  
 Model Description: M.2 card for the MAYA-W2 Wi-Fi 6, Bluetooth 5.3 and IEEE 802.15.4 module  
 Model: M2-MAYA-W271-00C  
 Test Sample ID: 49021  
 Test Site: Eurofins Product Service GmbH  
 Operator: Mr. Ibraimov  
 Measurement software: RadiMation, version 2023.2.6  
 Test Conditions: Tnom: 22 °Celsius, Vnom: 3.3 VDC  
 Antenna: Schwarzbeck BBHA 9120B  
 Measurement distance: 3 m  
 Mode: Tx; BT\_BR\_2402 MHz  
 Test Date: 2024-07-18

Index 39

RadiMation

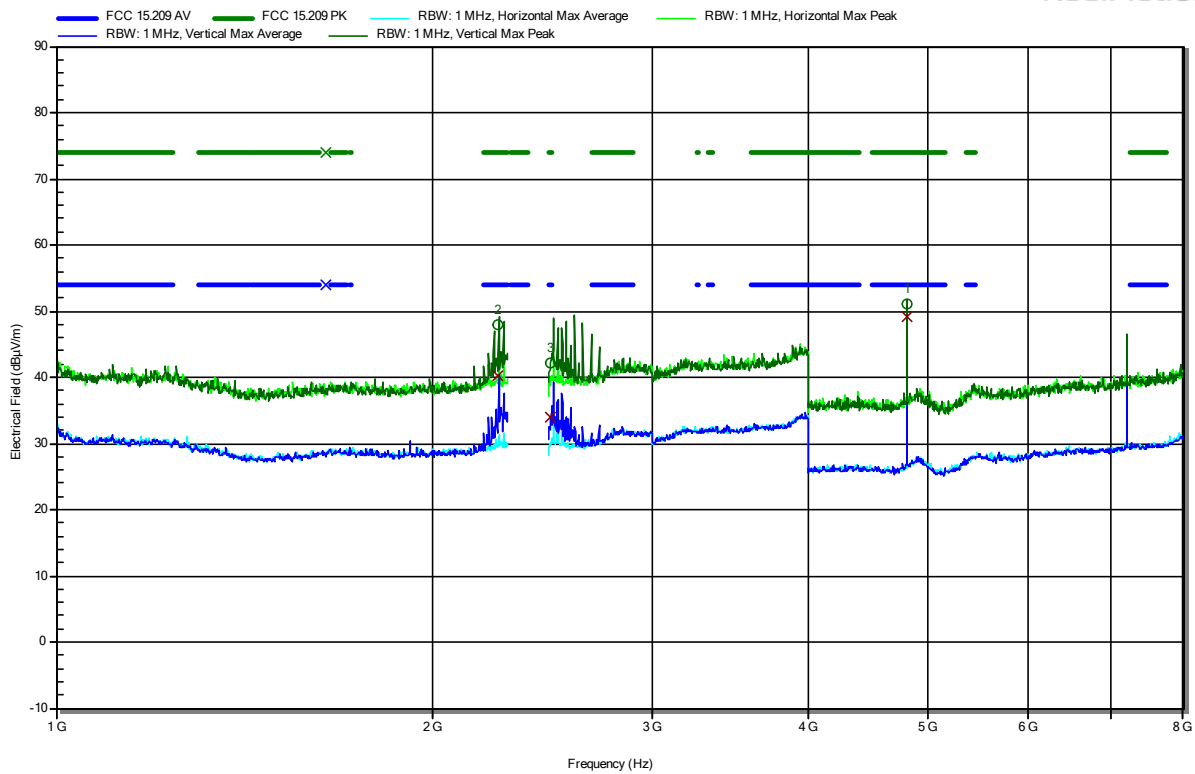

Peak Number	Frequency (MHz)	Peak (dBµV/m)	Peak Limit (dBµV/m)	Peak Difference (dB)	Peak Status	Polarization
1	4804.1333	51.08	74	-22.92	Pass	Vertical
2	2261.9967	47.96	74	-26.04	Pass	Vertical
3	2492.6496	42.25	74	-31.75	Pass	Vertical

Peak Number	Frequency (MHz)	Average (dBµV/m)	Average Limit (dBµV/m)	Average Difference (dB)	Average Status	Polarization
1	4804.1333	49.08	54	-4.92	Pass	Vertical
2	2261.9967	40.34	54	-13.66	Pass	Vertical
3	2492.6496	33.92	54	-20.08	Pass	Vertical

### Radiated Spurious Emissions according to 47 CFR Part 15.247, RSS-Gen Issue 5

Project Number: G0M-2405-2583  
 Applicant: u-blox AG  
 Model Description: M.2 card for the MAYA-W2 Wi-Fi 6, Bluetooth 5.3 and IEEE 802.15.4 module  
 Model: M2-MAYA-W271-00C  
 Test Sample ID: 49021  
 Test Site: Eurofins Product Service GmbH  
 Operator: Mr. Ibrahimov  
 Measurement software: RadiMation, version 2023.2.6  
 Test Conditions: Tnom: 22 °Celsius, Vnom: 3.3 VDC  
 Antenna: Schwarzbeck BBHA 9120B  
 Measurement distance: 3 m  
 Mode: Tx; BT\_BR\_2402 MHz  
 Test Date: 2024-07-17  
 Note: lower bandedge

Index 36

RadiMation

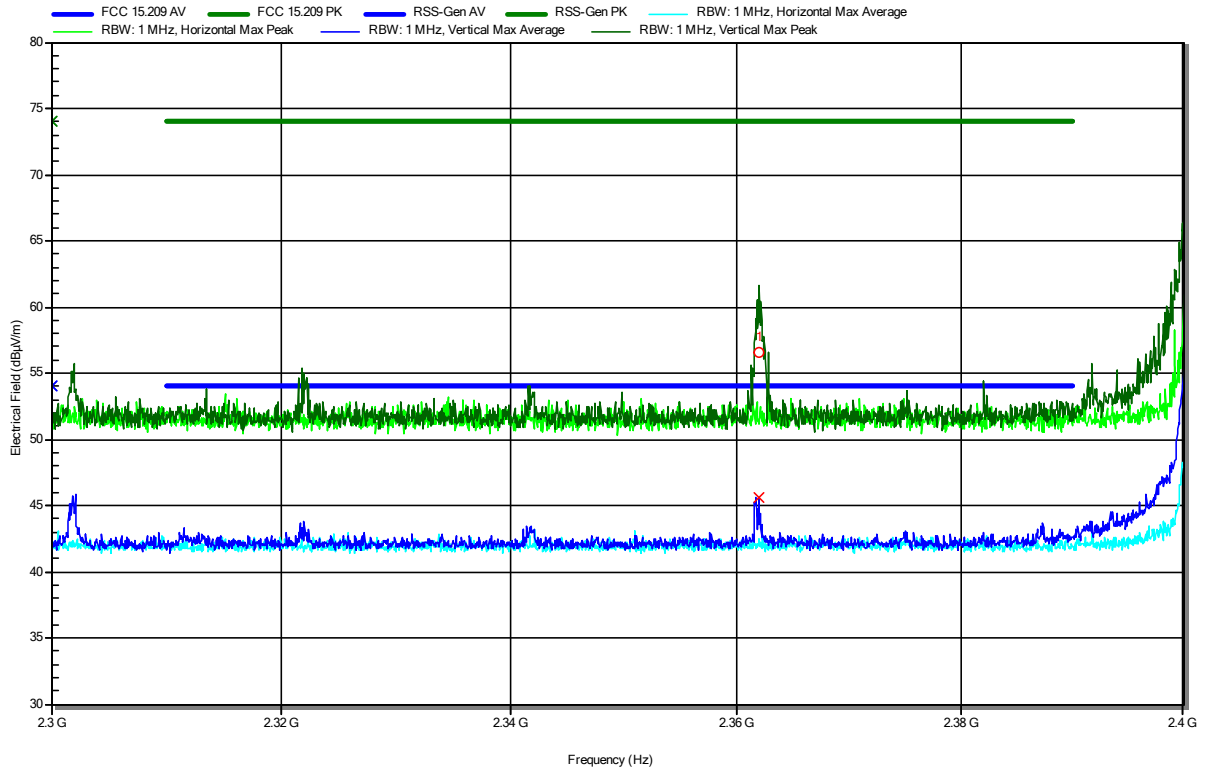

Peak Number	Frequency (MHz)	Peak (dBµV/m)	Peak Limit (dBµV/m)	Peak Difference (dB)	Peak Status	Polarization
1	2361.99	56.51	74	-17.49	Pass	Vertical
Peak Number	Frequency (MHz)	Average (dBµV/m)	Average Limit (dBµV/m)	Average Difference (dB)	Average Status	Polarization
1	2361.99	45.6	54	-8.4	Pass	Vertical

### Radiated Spurious Emissions according to 47 CFR Part 15.247, RSS-Gen Issue 5

Project Number: G0M-2405-2583  
 Applicant: u-blox AG  
 Model Description: M.2 card for the MAYA-W2 Wi-Fi 6, Bluetooth 5.3 and IEEE 802.15.4 module  
 Model: M2-MAYA-W271-00C  
 Test Sample ID: 49021  
 Test Site: Eurofins Product Service GmbH  
 Operator: Mr. Ibraimov  
 Measurement software: RadiMation, version 2023.2.6  
 Test Conditions: Tnom: 22 °Celsius, Vnom: 3.3 VDC  
 Antenna: Schwarzbeck BBHA 9120B  
 Measurement distance: 3 m  
 Mode: Tx; BT\_BR\_2480 MHz  
 Test Date: 2024-07-17  
 Note: upper bandedge

Index 37  
**RadiMation**

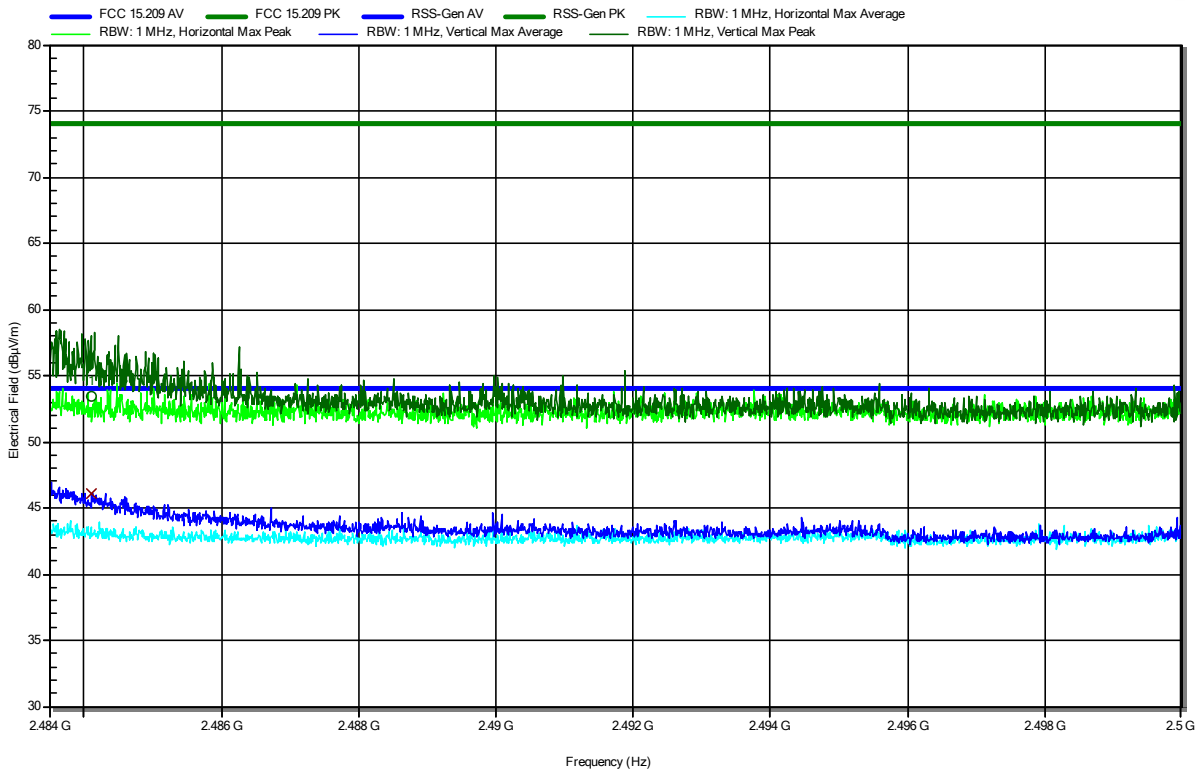

Peak Number	Frequency (MHz)	Peak (dBµV/m)	Peak Limit (dBµV/m)	Peak Difference (dB)	Peak Status	Polarization
1	2484.1237	53.4	74	-20.6	Pass	Vertical

Peak Number	Frequency (MHz)	Average (dBµV/m)	Average Limit (dBµV/m)	Average Difference (dB)	Average Status	Polarization
1	2484.1237	46.05	54	-7.95	Pass	Vertical

Test Report No.: G0M-2405-2583-TFC247BT-V02

Eurofins Product Service GmbH  
 Storkower Str. 38c, D-15526 Reichenwalde, Germany

### Radiated Spurious Emissions according to 47 CFR Part 15.247, RSS-Gen Issue 5

Project Number: G0M-2405-2583  
 Applicant: u-blox AG  
 Model Description: M.2 card for the MAYA-W2 Wi-Fi 6, Bluetooth 5.3 and IEEE 802.15.4 module  
 Model: M2-MAYA-W271-00C  
 Test Sample ID: 49021  
 Test Site: Eurofins Product Service GmbH  
 Operator: Mr. Ibraimov  
 Measurement software: RadiMation, version 2023.2.6  
 Test Conditions: Tnom: 22 °Celsius, Vnom: 3.3 VDC  
 Antenna: Schwarzbeck HWRD 650  
 Measurement distance: 3 m  
 Mode: Tx; BT\_BR\_2402 MHz  
 Test Date: 2024-07-17

Index 38  
**RadiMation**

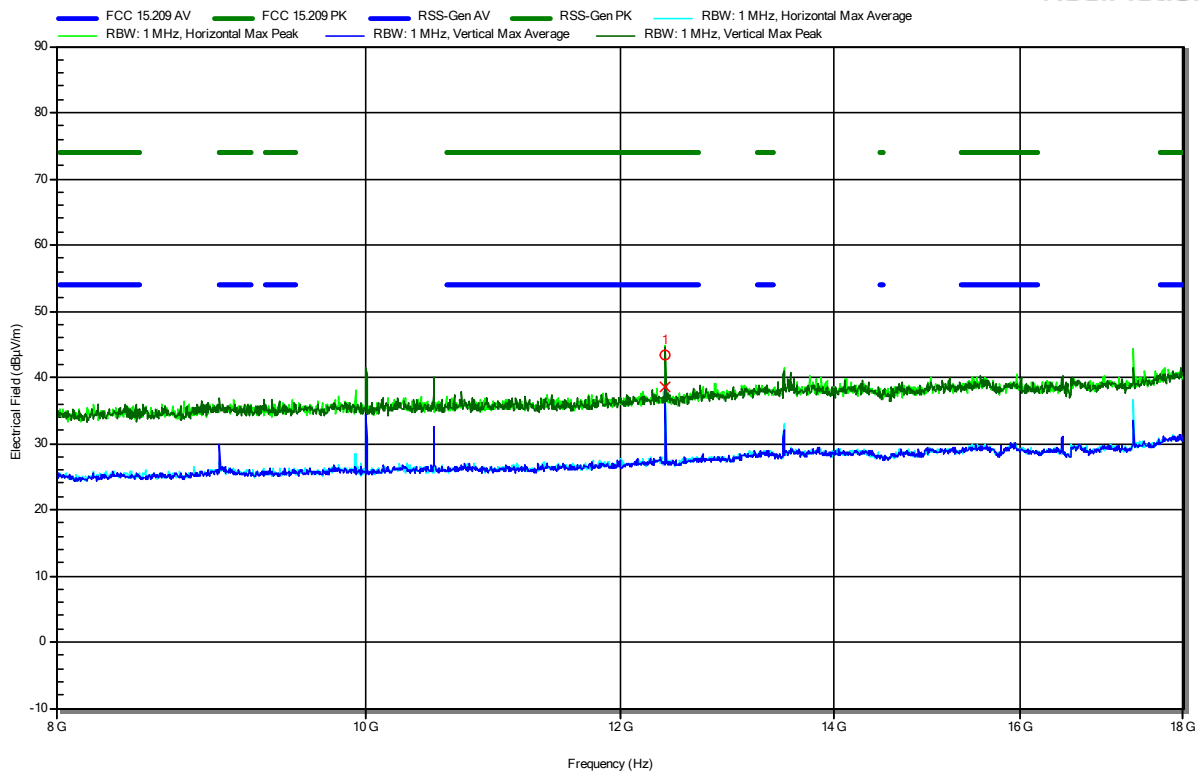

Peak Number	Frequency (MHz)	Peak (dBµV/m)	Peak Limit (dBµV/m)	Peak Difference (dB)	Peak Status	Polarization
1	12399.333	43.38	74	-30.62	Pass	Vertical
Peak Number	Frequency (MHz)	Average (dBµV/m)	Average Limit (dBµV/m)	Average Difference (dB)	Average Status	Polarization
1	12399.333	38.43	54	-15.57	Pass	Vertical

## ANNEX B Receiver spurious emissions

### Radiated Spurious Emissions according to RSS-Gen Issue 5

Project Number: G0M-2405-2583  
 Applicant: u-blox AG  
 Model Description: M.2 card for the MAYA-W2 Wi-Fi 6, Bluetooth 5.3 and IEEE 802.15.4 module  
 Model: M2-MAYA-W271-00C  
 Test Sample ID: 49021  
 Test Site: Eurofins Product Service GmbH  
 Operator: Mr. Ibraimov  
 Measurement software: RadiMation, version 2023.2.6  
 Test Conditions: Tnom: 22 °Celsius, Vnom: 3.3 VDC  
 Antenna: Schwarzbeck VULB 9168  
 Measurement distance: 3 m  
 Mode: Rx; BT\_BR\_Scan mode  
 Test Date: 2024-07-23

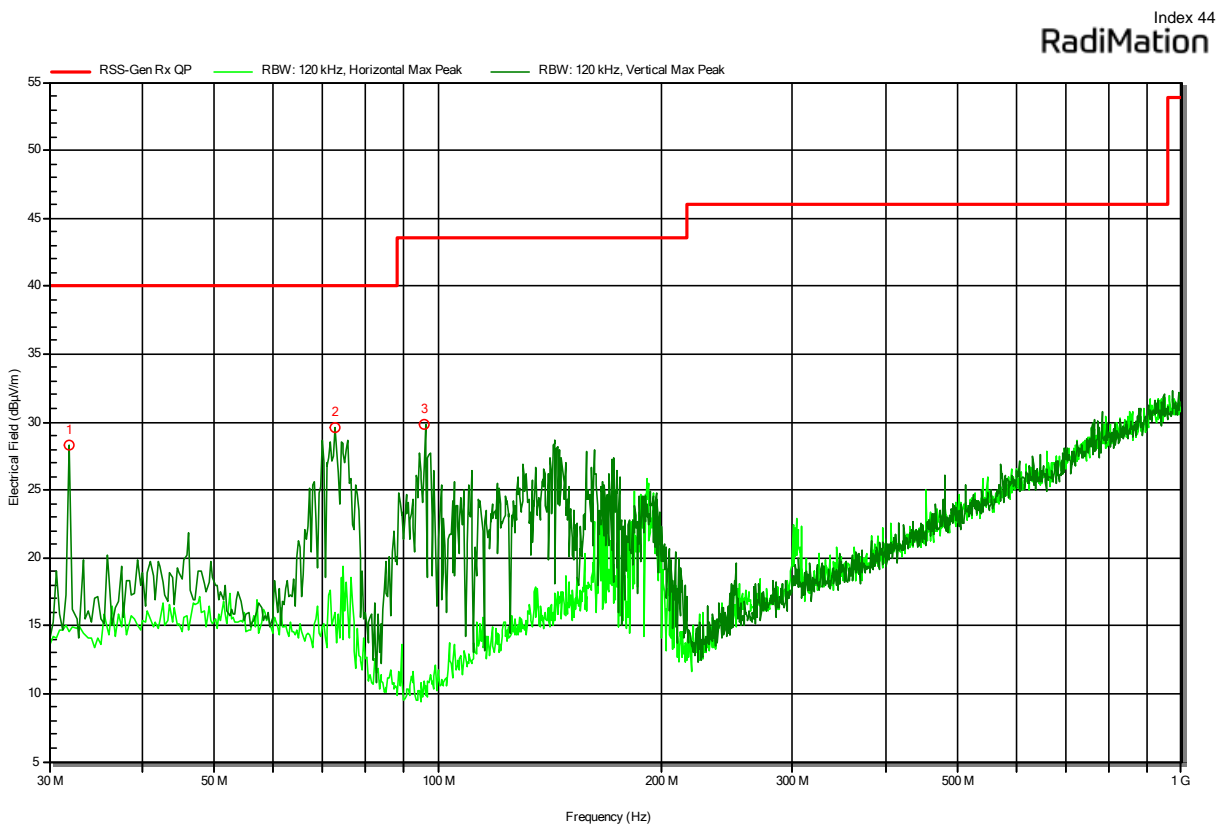

Peak Number	Frequency (MHz)	Peak (dBµV/m)	Peak Limit (dBµV/m)	Peak Difference (dB)	Peak Status	Polarization
1	31.94	28.3	40	-11.74	Pass	Vertical
2	72.68	29.6	40	-10.37	Pass	Vertical
3	95.96	29.8	43.5	-13.65	Pass	Vertical

### Radiated Spurious Emissions according to RSS-Gen Issue 5

Project Number: G0M-2405-2583  
 Applicant: u-blox AG  
 Model Description: M.2 card for the MAYA-W2 Wi-Fi 6, Bluetooth 5.3 and IEEE 802.15.4 module  
 Model: M2-MAYA-W271-00C  
 Test Sample ID: 49021  
 Test Site: Eurofins Product Service GmbH  
 Operator: Mr. Ibraimov  
 Measurement software: RadiMation, version 2023.2.6  
 Test Conditions: Tnom: 22 °Celsius, Vnom: 3.3 VDC  
 Antenna: Schwarzbeck BBHA 9120D  
 Measurement distance: 3 m  
 Mode: Rx; BT\_BR\_Scan mode  
 Test Date: 2024-07-19

Index 40  
**RadiMation**

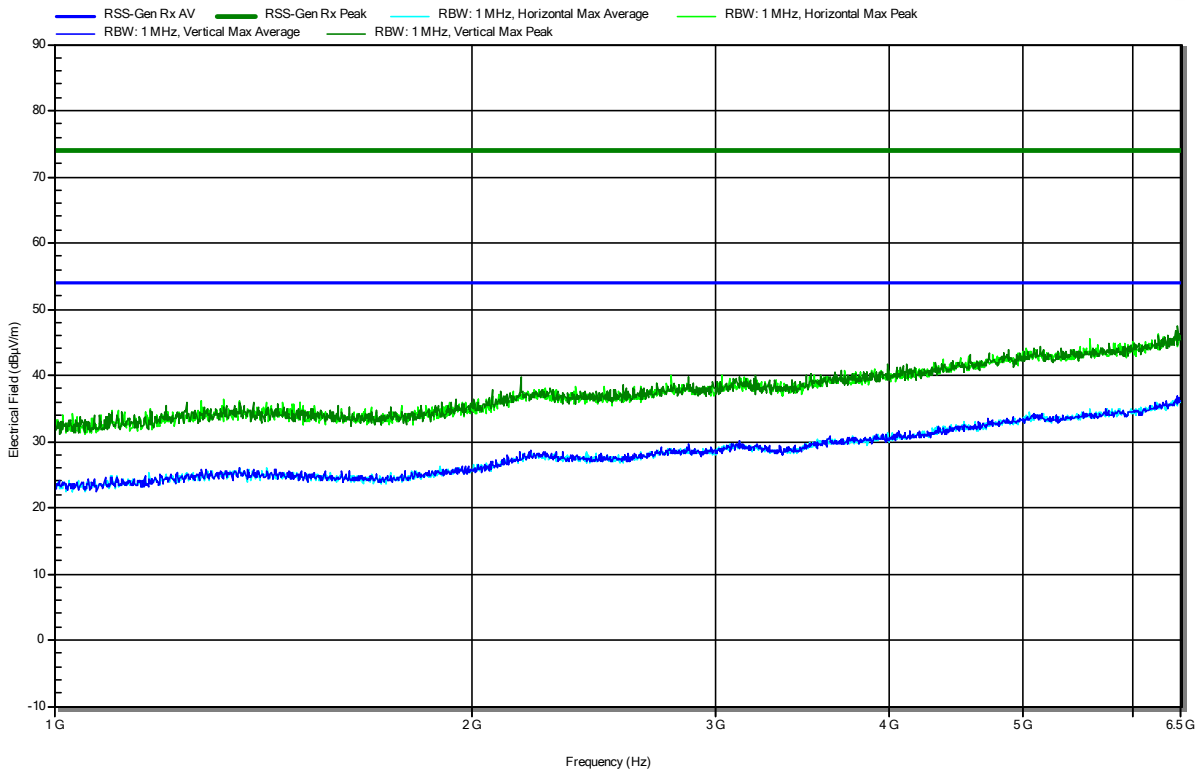



### Radiated Spurious Emissions according to RSS-Gen Issue 5

Project Number: G0M-2405-2583  
 Applicant: u-blox AG  
 Model Description: M.2 card for the MAYA-W2 Wi-Fi 6, Bluetooth 5.3 and IEEE 802.15.4 module  
 Model: M2-MAYA-W271-00C  
 Test Sample ID: 49021  
 Test Site: Eurofins Product Service GmbH  
 Operator: Mr. Ibraimov  
 Measurement software: RadiMation, version 2023.2.6  
 Test Conditions: Tnom: 22 °Celsius, Vnom: 3.3 VDC  
 Antenna: Schwarzbeck HWRD 650  
 Measurement distance: 3 m  
 Mode: Rx; BT\_BR\_Scan mode  
 Test Date: 2024-07-19

Index 41  
**RadiMation**

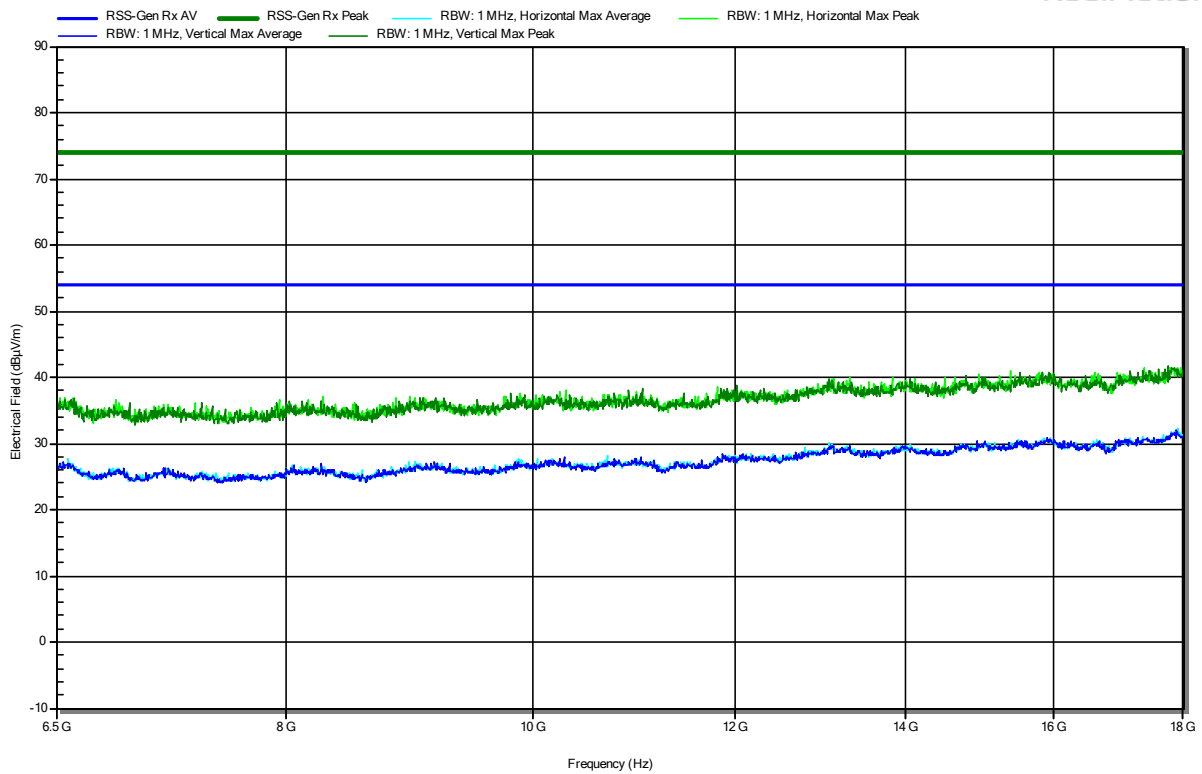

=== End of test report ===