

FCC Measurement/Technical Report on WLAN and Bluetooth Module MAYA-W161

FCC ID: XPYMAW161
IC: 8595A-MAYAW161

Test Report Reference: MDE_UBLOX_2404_FCC_02_rev01

Test Laboratory:

7layers GmbH
Borsigstrasse 11
40880 Ratingen
Germany



Deutsche
Akkreditierungsstelle
D-PL-12140-01-01
D-PL-12140-01-02
D-PL-12140-01-03

Note:

The following test results relate only to the devices specified in this document. This report shall not be reproduced in parts without the written approval of the test laboratory.

7layers GmbH
Borsigstraße 11
40880 Ratingen, Germany
T +49 (0) 2102 749 0
F +49 (0) 2102 749 350

Geschäftsführer/
Managing Directors:
Sebastian Doose
Bernhard Retka

Registergericht/registered:
Düsseldorf HRB 75554
USt-Id.-Nr./VAT-No. DE203159652
Steuer-Nr./TAX-No. 147/5869/0385

a Bureau Veritas
Group Company

www.7layers.com

Table of Contents

1	Applied Standards and Test Summary	3
1.1	Applied Standards	3
1.2	FCC-IC Correlation Table	4
1.3	Measurement Summary	5
2	Revision History / Signatures	8
3	Administrative Data	9
3.1	Testing Laboratory	9
3.2	Project Data	9
3.3	Applicant Data	9
3.4	Manufacturer Data	10
4	Test object Data	11
4.1	General EUT Description	11
4.2	EUT Main components	12
4.3	Ancillary Equipment	12
4.4	Auxiliary Equipment	13
4.5	EUT Setups	13
4.6	Operating Modes / Test Channels	14
4.7	Product labelling	14
5	Test Results	15
5.1	Maximum Conducted Output Power	15
5.2	Undesirable Emissions; General Field Strength Limits	21
5.3	Band Edge	42
6	Test Equipment	67
6.1	Test Equipment Hardware	67
6.2	Test Equipment Software	71
7	Antenna Factors, Cable Loss and Sample Calculations	72
7.1	LISN R&S ESH3-Z5 (150 kHz – 30 MHz)	72
7.2	Antenna R&S HFH2-Z2 (9 kHz – 30 MHz)	73
7.3	Antenna R&S HL562 (30 MHz – 1 GHz)	74
7.4	Antenna R&S HF907 (1 GHz – 18 GHz)	75
7.5	Antenna EMCO 3160-09 (18 GHz – 26.5 GHz)	76
7.6	Antenna EMCO 3160-10 (26.5 GHz – 40 GHz)	77
8	Measurement Uncertainties	78
9	Photo Report	79

1 APPLIED STANDARDS AND TEST SUMMARY

1.1 APPLIED STANDARDS

Type of Authorization

Certification for an Intentional Radiator (Digital Device / Spread Spectrum).

Applicable FCC Rules

Prepared in accordance with the requirements of FCC Rules and Regulations as listed in 47 CFR Ch.1 Parts 2 and 15 (10-1-23 Edition). The following subparts are applicable to the results in this test report.

Part 2, Subpart J - Equipment Authorization Procedures, Certification

Part 15, Subpart C – Intentional Radiators

§ 15.201 Equipment authorization requirement

§ 15.207 Conducted limits

§ 15.209 Radiated emission limits; general requirements

Part 15, Subpart E – Unlicensed National Information Infrastructure Devices

§ 15.403 Definitions

§ 15.407 General technical requirements

Note:

The tests were selected and performed with reference to the FCC KDB “Guidelines for Compliance Testing of Unlicensed National Information Infrastructure (U-NII) Devices - Part 15, Subpart E, 789033 D02 General U-NII Test Procedures New Rules v02r01, 2017-12-14”.

ANSI C63.10-2013 is applied.

1.2 FCC-IC CORRELATION TABLE

Correlation of measurement requirements for UNII / LE-LAN (e.g. WLAN 5 GHz) equipment from FCC and IC

UNII equipment

Measurement	FCC reference	IC reference
Conducted emissions on AC Mains	§ 15.207	RSS-Gen Issue 5 & AMD 1 & AMD 2: 8.8
Occupied bandwidth	§ 15.403 (26 dB) / § 15.407 (e) (6 dB)	RSS-247 Issue 3: 6.2.1.1, 6.2.2.1, 6.2.3.1 (99%) RSS-247 Issue 3: 6.2.4.2 (6 dB) RSS-248 Issue 2: 4.4
Maximum conducted output power	§ 15.407 (a) (1) to (8), (11)	RSS-247 Issue 3: 6.2.1.1, 6.2.2.1, 6.2.3.1, 6.2.4.2 RSS-248 Issue 2: 4.5
Maximum power spectral density	§ 15.407 (a) (1) to (8), (12)	RSS-247 Issue 3: 6.2.1.1, 6.2.2.1, 6.2.3.1, 6.2.4.1 RSS-248 Issue 2: 4.5
Transmitter undesirable emissions; General Field Strength Limits, Restricted Bands, In-Band Emissions	§ 15.407 (b) § 15.209 (a)	RSS-Gen Issue 5: 6.13/8.9/8.10; RSS-247 Issue 3: 3.3/6.2 6.2.1.2, 6.2.2.2, 6.2.3.2, 6.2.4.2 RSS-248 Issue 2: 4.6
Frequency stability	§ 15.407 (g)	RSS-Gen Issue 5: 6.11/8.11
Transmit Power Control (TPC) and Dynamic Frequency Selection (DFS)	§ 15.407 (h)	RSS-247 Issue 3: 6.2.2.1, 6.2.3.1, 6.3
Antenna requirement	§ 15.203 / 15.204 § 15.407 (a) (9)	RSS-Gen Issue 5 & AMD 1 & AMD 2: 8.3
Contention Based Protocol	§ 15.407 (d) (6)	RSS-248 Issue 2: 4.7
Receiver spurious emissions	-	-

1.3 MEASUREMENT SUMMARY

47 CFR CHAPTER I FCC PART 15 Subpart E §15.407

FCC §15.31, §15.407 (a)(1)

Maximum Conducted Output Power

The measurement was performed according to ANSI C63.10, chapter 12.3.3.2

Final Result

OP-Mode Radio Technology, Operating Frequency, Subband	Setup	Date	FCC	IC
WLAN a, high, U-NII-1	S04_161_AA01	2024-07-05	Passed	Passed
WLAN a, high, U-NII-2A	S04_161_AA01	2024-07-05	Passed	Passed
WLAN a, high, U-NII-2C	S04_161_AA01	2024-07-05	Passed	Passed
WLAN a, high, U-NII-3	S04_161_AA01	2024-07-05	Passed	Passed
WLAN a, low, U-NII-1	S04_161_AA01	2024-07-05	Passed	Passed
WLAN a, low, U-NII-2A	S04_161_AA01	2024-07-05	Passed	Passed
WLAN a, low, U-NII-2C	S04_161_AA01	2024-07-05	Passed	Passed
WLAN a, low, U-NII-3	S04_161_AA01	2024-07-05	Passed	Passed
WLAN a, mid, U-NII-1	S04_161_AA01	2024-08-19	Passed	Passed
WLAN a, mid, U-NII-2A	S04_161_AA01	2024-07-05	Passed	Passed
WLAN a, mid, U-NII-2C	S04_161_AA01	2024-07-05	Passed	Passed
WLAN a, mid, U-NII-3	S04_161_AA01	2024-07-05	Passed	Passed
WLAN n 20 MHz, high, U-NII-1	S04_161_AA01	2024-07-05	Passed	Passed
WLAN n 20 MHz, high, U-NII-2A	S04_161_AA01	2024-07-05	Passed	Passed
WLAN n 20 MHz, high, U-NII-2C	S04_161_AA01	2024-07-05	Passed	Passed
WLAN n 20 MHz, high, U-NII-3	S04_161_AA01	2024-07-05	Passed	Passed
WLAN n 20 MHz, low, U-NII-1	S04_161_AA01	2024-07-05	Passed	Passed
WLAN n 20 MHz, low, U-NII-2A	S04_161_AA01	2024-07-05	Passed	Passed
WLAN n 20 MHz, low, U-NII-2C	S04_161_AA01	2024-07-05	Passed	Passed
WLAN n 20 MHz, low, U-NII-3	S04_161_AA01	2024-07-05	Passed	Passed
WLAN n 20 MHz, mid, U-NII-1	S04_161_AA01	2024-08-19	Passed	Passed
WLAN n 20 MHz, mid, U-NII-2A	S04_161_AA01	2024-07-05	Passed	Passed
WLAN n 20 MHz, mid, U-NII-2C	S04_161_AA01	2024-07-05	Passed	Passed
WLAN n 20 MHz, mid, U-NII-3	S04_161_AA01	2024-07-05	Passed	Passed
WLAN n 40 MHz, high, U-NII-1	S04_161_AA01	2024-08-20	Passed	Passed
WLAN n 40 MHz, high, U-NII-2A	S04_161_AA01	2024-08-20	Passed	Passed
WLAN n 40 MHz, high, U-NII-2C	S04_161_AA01	2024-08-20	Passed	Passed
WLAN n 40 MHz, high, U-NII-3	S04_161_AA01	2024-08-20	Passed	Passed
WLAN n 40 MHz, low, U-NII-1	S04_161_AA01	2024-08-20	Passed	Passed
WLAN n 40 MHz, low, U-NII-2A	S04_161_AA01	2024-08-20	Passed	Passed
WLAN n 40 MHz, low, U-NII-2C	S04_161_AA01	2024-08-20	Passed	Passed
WLAN n 40 MHz, low, U-NII-3	S04_161_AA01	2024-08-20	Passed	Passed
WLAN n 40 MHz, mid, U-NII-2C	S04_161_AA01	2024-08-20	Passed	Passed

**47 CFR CHAPTER I FCC PART 15
Subpart E §15.407**

**FCC §15.407 (b), (1),(2),(3),(4); FCC
§15.205, §15.209, §15.407 (b) (5),(6)**

Undesirable Emissions; General Field Strength Limits

The measurement was performed according to ANSI C63.10, chapter
6.4, 6.5, 6.6.5

Final Result

OP-Mode Radio Technology, Operating Frequency, Measurement range, Subband	Setup	Date	FCC	IC
WLAN a, high, 1GHz - 26GHz, U-NII-3 Remark: harmonics tested only	S02_161_AG01	2024-07-21	Passed	Passed
WLAN a, high, 1GHz - 26GHz, U-NII-3 Remark: harmonics tested only	S03_161_AG01	2024-07-27	Passed	Passed
WLAN a, low, 1GHz - 26GHz, U-NII-2A Remark: harmonics tested only	S02_161_AG01	2024-07-21	Passed	Passed
WLAN a, low, 1GHz - 26GHz, U-NII-2A Remark: harmonics tested only	S03_161_AG01	2024-07-27	Passed	Passed
WLAN a, mid, 1GHz - 26GHz, U-NII-1	S02_161_AG01	2024-07-15	Passed	Passed
WLAN a, mid, 1GHz - 26GHz, U-NII-1	S03_161_AG01	2024-07-24	Passed	Passed
WLAN a, mid, 1GHz - 26GHz, U-NII-2C Remark: harmonics tested only	S02_161_AG01	2024-07-17	Passed	Passed
WLAN a, mid, 1GHz - 26GHz, U-NII-2C Remark: harmonics tested only	S03_161_AG01	2024-07-27	Passed	Passed
WLAN a, mid, 30MHz - 1GHz, U-NII-1	S02_161_AG01	2024-07-09	Passed	Passed
WLAN a, mid, 30MHz - 1GHz, U-NII-1	S03_161_AG01	2024-08-12	Passed	Passed
WLAN a, mid, 9kHz - 30MHz, U-NII-1	S02_161_AG01	2024-07-09	Passed	Passed
WLAN a, mid, 9kHz - 30MHz, U-NII-1	S03_161_AG01	2024-08-12	Passed	Passed
WLAN n 40 MHz, low, 1GHz - 26GHz, U-NII- 2C	S02_161_AG01	2024-07-21	Passed	Passed

**47 CFR CHAPTER I FCC PART 15
Subpart E §15.407**

FCC §15.407 (b), (1),(2),(3),(4)

Band Edge

The measurement was performed according to ANSI C63.10, chapter
6.6.5

Final Result

OP-Mode Radio Technology, Operating Frequency, Subband	Setup	Date	FCC	IC
WLAN a, high, U-NII-2A	S02_161_AG01	2024-07-21	Passed	Passed
WLAN a, high, U-NII-2A	S03_161_AG01	2024-07-27	Passed	Passed
WLAN a, high, U-NII-2C	S02_161_AG01	2024-07-01	Passed	Passed
WLAN a, high, U-NII-2C	S03_161_AG01	2024-07-27	Passed	Passed
WLAN a, high, U-NII-3	S02_161_AG01	2024-07-21	Passed	Passed
WLAN a, high, U-NII-3	S03_161_AG01	2024-07-27	Passed	Passed
WLAN a, low, U-NII-1	S02_161_AG01	2024-07-17	Passed	Passed
WLAN a, low, U-NII-1	S03_161_AG01	2024-07-26	Passed	Passed
WLAN a, low, U-NII-2C	S02_161_AG01	2024-07-21	Passed	Passed
WLAN a, low, U-NII-2C	S03_161_AG01	2024-07-27	Passed	Passed
WLAN a, low, U-NII-3	S02_161_AG01	2024-07-21	Passed	Passed
WLAN a, low, U-NII-3	S03_161_AG01	2024-07-27	Passed	Passed
WLAN n 20 MHz, low, U-NII-1	S02_161_AG01	2024-07-21	Passed	Passed

**47 CFR CHAPTER I FCC PART 15
Subpart E §15.407**

FCC §15.407 (b), (1),(2),(3),(4)

Band Edge

The measurement was performed according to ANSI C63.10, chapter 6.6.5

Final Result

OP-Mode Radio Technology, Operating Frequency, Subband	Setup	Date	FCC	IC
WLAN n 20 MHz, low, U-NII-1	S03_161_AG01	2024-07-27	Passed	Passed
WLAN n 20 MHz, low, U-NII-2C	S02_161_AG01	2024-08-20	Passed	Passed
WLAN n 20 MHz, low, U-NII-2C	S03_161_AG01	2024-07-27	Passed	Passed
WLAN n 40 MHz, low, U-NII-1	S02_161_AG01	2024-07-27	Passed	Passed
WLAN n 40 MHz, low, U-NII-1	S03_161_AG01	2024-07-27	Passed	Passed
WLAN n 40 MHz, low, U-NII-2C	S02_161_AG01	2024-07-27	Passed	Passed
WLAN n 40 MHz, low, U-NII-2C	S03_161_AG01	2024-07-27	Passed	Passed

N/A: Not applicable

N/P: Not performed

2 REVISION HISTORY / SIGNATURES

Report version control			
Version	Release date	Change Description	Version validity
initial	2024-09-12	--	valid
rev01	2024-11-07	Administrative changes	valid

COMMENT: This test is a spot check report for antenna with higher gain at reduced power settings. Not all tests were performed. Full testing was performed in report:
MDE_UBLOX_2110_FCC_02



(responsible for accreditation scope)
Dipl.-Ing. Daniel Gall



(responsible for testing and report)
B.Sc. Mohamed Fraitat



7 layers GmbH, Borsigstr. 11
40880 Ratingen, Germany
Phone +49 (0)2102 749 0

3 ADMINISTRATIVE DATA

3.1 TESTING LABORATORY

Company Name: 7layers GmbH
Address: Borsigstr. 11
40880 Ratingen
Germany

The test facility is accredited by the following accreditation organisation:

Laboratory accreditation no: DAKKS D-PL-12140-01-01 | -02 | -03
FCC Designation Number: DE0015
FCC Test Firm Registration: 929146
ISED CAB Identifier DE0007; ISED#: 3699A

Responsible for accreditation scope: Dipl.-Ing. Daniel Gall

Report Template Version: 2023-09-29

3.2 PROJECT DATA

Responsible for testing and report: B.Sc. Mohamed Fraitat
Employees who performed the tests: documented internally at 7Layers
Date of Report: 2024-10-11
Testing Period: 2024-07-01 to 2024-08-20

3.3 APPLICANT DATA

Company Name: u-blox AG
Address: Zürcherstrasse 68
8800 Thalwil
Switzerland
Contact Person: Filip Kruzela

3.4 MANUFACTURER DATA

Company Name: please see Applicant Data

Address:

Contact Person:

4 TEST OBJECT DATA

4.1 GENERAL EUT DESCRIPTION

Kind of Device product description	Host-based module with WLAN and Bluetooth technology																																																																																																																		
Product name	MAYA-W161-00B																																																																																																																		
Type	MAYA-W161-00B																																																																																																																		
PMN	MAYA W161-00B																																																																																																																		
HVIN	MAYA W161-00B																																																																																																																		
Declared EUT data by the supplier																																																																																																																			
Voltage Type	DC																																																																																																																		
Voltage Level	1.8 V + 3.3 V																																																																																																																		
Tested Modulation Type	OFDM																																																																																																																		
Specific product description	<p>The EUT is a Bluetooth and WLAN module. In the 5 GHz band it supports SISO Mode only. Supported WLAN modes are a and n with a 20 MHz BW, n with 40 MHz BW. The U-NII bands 1, 2A, 2C and 3 are supported. For this report the EUT is a slave without radar detection in the relevant DFS bands.</p>																																																																																																																		
Ports of the device	<p>Enclosure Data DC Power Antenna</p> <p>The EUT is a module with solder pads for surface mounting, so no cables were connected to the EUT itself.</p>																																																																																																																		
Antenna	<p>5.3 dBi (Taoglas) / 4.0 dBi (Molex) 5.3 dBi is used for E.I.R.P. calculation of conducted measurements.</p>																																																																																																																		
Tested Datarates	<p>WLAN a: 6 Mbit WLAN n: MCS 0</p>																																																																																																																		
Special software used for testing	Scripts were provided by the applicant on a laptop that control a board computer, which sets the test modes of the EUT.																																																																																																																		
Used output power	<table border="1"> <thead> <tr> <th colspan="2"></th> <th colspan="16">5 GHz</th> </tr> <tr> <th>Mode</th> <th>Ch.</th> <th>36</th> <th>40</th> <th>44</th> <th>48</th> <th>52</th> <th>56</th> <th>60</th> <th>64</th> <th>100</th> <th>104</th> <th>108</th> <th>112</th> <th>116</th> <th>132</th> <th>136</th> <th>140</th> <th>144</th> <th>149</th> <th>153</th> <th>157</th> <th>161</th> <th>165</th> </tr> </thead> <tbody> <tr> <td>A</td> <td></td> <td>14</td> <td>14</td> <td>14</td> <td>14</td> <td>14</td> <td>14</td> <td>14</td> <td>13</td> <td>13</td> <td>15</td> <td>15</td> <td>15</td> <td>15</td> <td>15</td> <td>13</td> <td>11</td> <td>-</td> <td>13</td> <td>13</td> <td>14</td> <td>15</td> <td>15</td> </tr> <tr> <td>N20 SISO</td> <td></td> <td>13</td> <td>13</td> <td>13</td> <td>13</td> <td>13</td> <td>13</td> <td>13</td> <td>12</td> <td>12</td> <td>13</td> <td>13</td> <td>13</td> <td>13</td> <td>13</td> <td>13</td> <td>11</td> <td>-</td> <td>13</td> <td>13</td> <td>13</td> <td>13</td> <td>13</td> </tr> <tr> <td>N40 SISO</td> <td></td> <td>11</td> <td>13</td> <td>13</td> <td>13</td> <td>13</td> <td>11</td> <td>10</td> <td>13</td> <td>N/A</td> <td>10</td> <td>-</td> <td>-</td> <td>13</td> <td>13</td> <td>13</td> <td>N/A</td> <td></td> <td>13</td> <td>13</td> <td>13</td> <td>13</td> <td>N/A</td> </tr> </tbody> </table> <p>Note by laboratory: Power is reduced by 3 dB compared to original certification, while antenna gain is raised by 3.3 / 2 dB.</p>			5 GHz																Mode	Ch.	36	40	44	48	52	56	60	64	100	104	108	112	116	132	136	140	144	149	153	157	161	165	A		14	14	14	14	14	14	14	13	13	15	15	15	15	15	13	11	-	13	13	14	15	15	N20 SISO		13	13	13	13	13	13	13	12	12	13	13	13	13	13	13	11	-	13	13	13	13	13	N40 SISO		11	13	13	13	13	11	10	13	N/A	10	-	-	13	13	13	N/A		13	13	13	13	N/A
		5 GHz																																																																																																																	
Mode	Ch.	36	40	44	48	52	56	60	64	100	104	108	112	116	132	136	140	144	149	153	157	161	165																																																																																												
A		14	14	14	14	14	14	14	13	13	15	15	15	15	15	13	11	-	13	13	14	15	15																																																																																												
N20 SISO		13	13	13	13	13	13	13	12	12	13	13	13	13	13	13	11	-	13	13	13	13	13																																																																																												
N40 SISO		11	13	13	13	13	11	10	13	N/A	10	-	-	13	13	13	N/A		13	13	13	13	N/A																																																																																												

4.2 EUT MAIN COMPONENTS

Sample Name	Sample Code	Description
MAYA-W161 AA01	DE1015158aa01	
Sample Parameter	Value	
Serial No.	M416C1DEB90BB4C0400	
HW Version	04	
SW Version	W16.92.21.p22-16.92.21.p22-MXM5X16298_V0	
Comment		

Sample Name	Sample Code	Description
MAYA-W161 AG01	DE1015158ag01	
Sample Parameter	Value	
Serial No.	M416C1DEB930E4C0400	
HW Version	04	
SW Version	W16.92.21.p22-16.92.21.p22-MXM5X16298_V0	
Comment		

NOTE: The short description is used to simplify the identification of the EUT in this test report.

4.3 ANCILLARY EQUIPMENT

For the purposes of this test report, ancillary equipment is defined as equipment which is used in conjunction with the EUT to provide operational and control features to the EUT. It is necessary to configure the system in a typical fashion, as a customer would normally use it. But nevertheless Ancillary Equipment can influence the test results.

Device	Details (Manufacturer, Type Model, OUT Code)	Description
-	-	-

4.4 AUXILIARY EQUIPMENT

For the purposes of this test report, auxiliary equipment is defined as equipment which is used temporarily to enable operational and control features especially used for the tests of the EUT which is not used during normal operation or equipment that is used during the tests in combination with the EUT but is not subject of this test report. It is necessary to configure the system in a typical fashion, as a customer would normally use it. But nevertheless Auxiliary Equipment can influence the test results.

Device	Details (Manufacturer, Type Model, HW, SW, S/N)	Description
AUX 01	Molex, 146153-0100, -, - , -	Molex PCB Antenna gain 2.4 GHz: 3.0 dBi 5 GHz: 4.0 dBi
AUX 03	Taoglas, GW.59.3153, -, - , -	Taoglas Dipole Antenna gain 2.4 GHz: 3.8 dBi 5 GHz: 5.3 dBi
AUX 04	NXP, i.MX 8M MINI on 8MMINI-BB, REV A5, -, TR23390198	Board Computer connected to Evaluation board for setting modes
AUX 05	UBLOX, MAYA-W1 EVK, Rev. A, - , 10000002626314002004	Evaluation board for module providing ports
AUX 06	UBLOX, MAYA-W1 EVK, Rev. A, - , 10000003544133005001	Evaluation board for module providing ports

4.5 EUT SETUPS

This chapter describes the combination of EUTs and equipment used for testing. The rationale for selecting the EUTs, ancillary and auxiliary equipment and interconnecting cables, is to test a representative configuration meeting the requirements of the referenced standards.

Setup	Combination of EUTs	Description and Rationale
S02_161_AG01	MAYA-W161 AG01, AUX 03, AUX 06,	With Taoglas Antenna
S03_161_AG01	MAYA-W161 AG01, AUX 01, AUX 06,	With Molex Antenna
S04_161_AA01	MAYA-W161 AA01, AUX 05, AUX 04,	Conducted Setup

4.6 OPERATING MODES / TEST CHANNELS

This chapter describes the operating modes of the EUTs used for testing.

U-NII-Subband 1 5150 - 5250 MHz			U-NII-Subband 2A 5250 - 5350 MHz			U-NII-Subband 2C 5470 - 5725 MHz			U-NII-Subband 3 5725 - 5850 MHz			Nom. BW
low	mid	high	low	mid	high	low	mid	high	low	mid	high	20 MHz
36	40	48	52	60	64	100	116	140	149	157	165	Ch.-No.
5180	5200	5240	5260	5300	5320	5500	5580	5700	5745	5785	5825	MHz

low	mid	high	low	mid	high	low	mid	high	low	mid	high	40 MHz
38	-	46	54	-	62	102	110	134	151	-	159	Ch.-No.
5190	-	5230	5270	-	5310	5510	5550	5670	5755	-	5795	MHz

4.7 PRODUCT LABELLING

4.7.1 FCC ID LABEL

Please refer to the documentation of the applicant.

4.7.2 LOCATION OF THE LABEL ON THE EUT

Please refer to the documentation of the applicant.

5 TEST RESULTS

5.1 MAXIMUM CONDUCTED OUTPUT POWER

Standard **FCC Part 15 Subpart E**

The test was performed according to:

ANSI C63.10, chapter 12.3.3.2

5.1.1 TEST DESCRIPTION

The Equipment Under Test (EUT) was set up to perform the output power measurements. The results recorded were measured with the modulation which produces the worst-case (highest) output power

For U-NII bands 1, 2A, 2C, 3:

The EUT was connected to the test system as described in the block diagram below. The complete attenuation of the measurement path is known and considered.

The OSP-B157W is a gated RF average power meter with a signal bandwidth > 300 MHz.

Note:

The measurement was performed according FCC Public Note "Guidelines for Compliance Testing of Unlicensed National Information Infrastructure (U-NII) Devices - Part 15, Subpart E, 789033 D02", method **PM-G**.

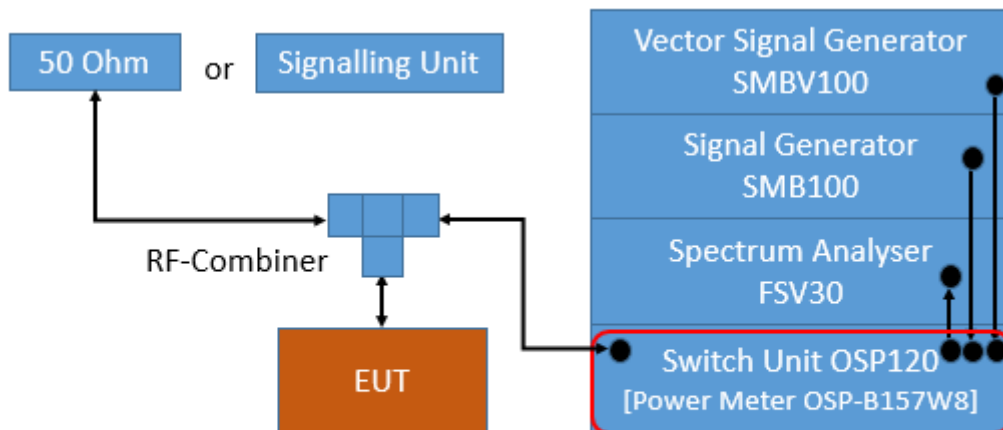

TS8997; Maximum Conducted Output Power

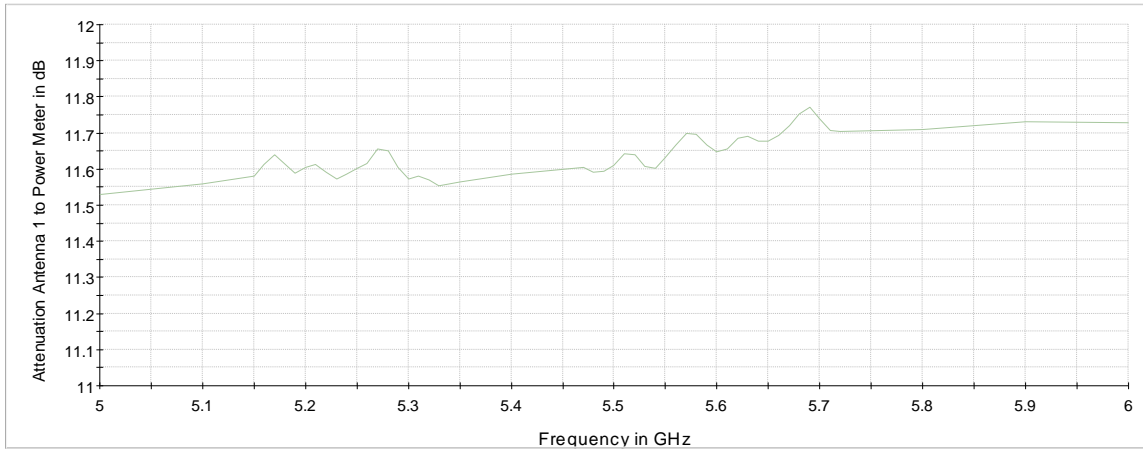

Attenuation of measurement path

For U-NII bands 5,6,7,8:

The EUT was connected to the test system as described in the block diagram below. The complete attenuation of the measurement path is known and considered.

Analyzer settings:

- Resolution Bandwidth (RBW): 1 MHz
- Video Bandwidth (VBW): 3 MHz
- Trace: Average, RMS power averaging mode
- Sweeps: at least 100
- Sweeptime: Auto
- Detector: RMS
- Trigger: free run (DC > 98 %) or gated mode (DC < 98 %)

See worst case result plots for details

Note:

The measurement was performed according FCC Public Note "Guidelines for Compliance Testing of Unlicensed National Information Infrastructure (U-NII) Devices - Part 15, Subpart E, 789033 D02", method **SA-1**.

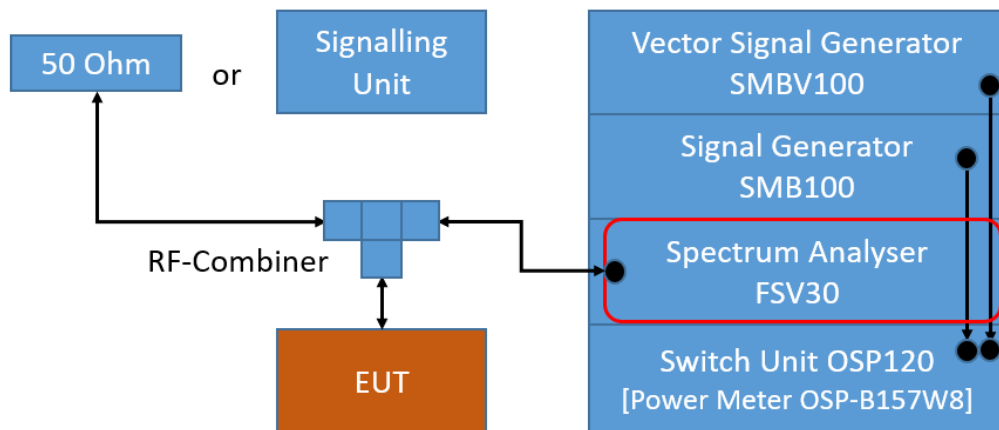

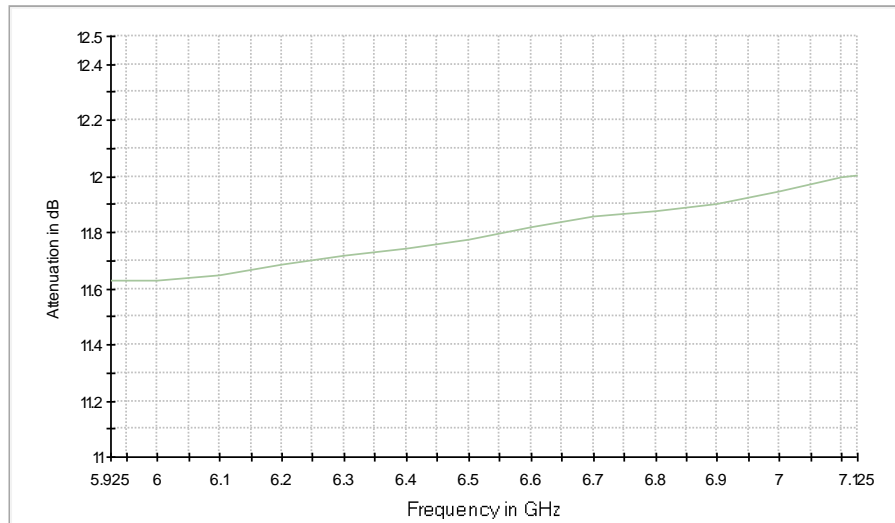

Attenuation of measurement path

5.1.2 TEST REQUIREMENTS / LIMITS

A) FCC

FCC Part 15, Subpart E, §15.407 (a) (1) (i): Outdoor access point:

For systems using digital modulation techniques in the 5.15 – 5.25 GHz bands:

Limit: 1 W (30 dBm) provided the maximum antenna gain does not exceed 6 dBi.

The maximum e.i.r.p. at any elevation angle above 30 degrees as measured from the horizon must not exceed 125 mW (21 dBm).

§15.407 (a) (1) (ii): Indoor access point:

Limit: 1 W (30 dBm) provided the maximum antenna gain does not exceed 6 dBi.

§15.407 (a) (1) (iii): Fixed point-to-point access points:

Limit: 1 W (30 dBm) provided the maximum antenna gain does not exceed 23 dBi.

§15.407 (a) (1) (iv): Client devices:

Limit: 250 mW (24 dBm) provided the maximum antenna gain does not exceed 6 dBi.

FCC Part 15, Subpart E, §15.407 (a) (2)

For systems using digital modulation techniques in the 5.25 – 5.35 GHz and 5.47 – 5.725 GHz bands:

Limit: 250 mW (24 dBm) or 11 dBm + 10 log (26 dB bandwidth/MHz) whatever is the lesser.

FCC Part 15, Subpart E, §15.407 (a) (3):

For systems using digital modulation techniques in the 5.725 – 5.850 GHz bands:

Limit: 1 W (30 dBm) provided the maximum antenna gain does not exceed 6 dBi. The antenna gain limitation is not applicable for fixed point-to-point devices.

FCC Part 15, Subpart E, §15.407 (a) (4):

For a standard power access point and fixed client devices in the 5.925 – 6.425 GHz and 6.525 – 6.875 GHz bands:

Limit: 4 W (36 dBm) e.i.r.p.

For outdoor devices, the maximum e.i.r.p. at any elevation angle above 30 degrees as measured from the horizon must not exceed 125 mW (21 dBm).

FCC Part 15, Subpart E, §15.407 (a) (5):

For an indoor access point in the 5.925 – 7.125 GHz bands:
Limit: 1 W (30 dBm)e.i.r.p.

FCC Part 15, Subpart E, §15.407 (a) (6):

For a subordinate device operating under an indoor access point in the 5.925 – 7.125 GHz bands:
Limit: 1 W (30 dBm)e.i.r.p.

FCC Part 15, Subpart E, §15.407 (a) (7):

For a client device, except for fixed client devices, operating under standard power access point in the 5.925-6.425 GHz and 6.525-6.875 GHz bands:
Limit: 1 W (30 dBm)e.i.r.p.
The client device must limit its power to no more than 6 dB below its associated standard power access point's authorized transmit power.

FCC Part 15, Subpart E, §15.407 (a) (8):

For client devices operating under the control of an indoor access point in the 5.925 – 7.125 GHz bands:
Limit: 250 mW (24 dBm)e.i.r.p.

FCC Part 15, Subpart E, §15.407 (a) (11):

The maximum conducted output power must be measured over any interval of continuous transmission using instrumentation calibrated in terms of an rms-equivalent voltage.

B) IC

Different frequency bands and limits apply, as compared to the FCC requirements.

All frequency bands: B is the 99% emission bandwidth in MHz.

RSS-247, 6.2.1.1, Band 5150-5250 MHz, indoor operation only, except for OEM devices installed by vehicle manufacturers:

Limits:

For OEM devices installed in vehicles, the maximum e.i.r.p. shall not exceed 30 mW or $1.76 + 10 \log_{10}B$, dBm, whichever is less. Devices shall implement transmitter power control (TPC) in order to have the capability to operate at least 3 dB below the maximum permitted e.i.r.p. of 30 mW. (e.i.r.p.)

Other devices: 200 mW (23 dBm) or $10 + 10 \log_{10}B$ [dBm], whichever power is less.

RSS-247, 6.2.2.1, Band 5250-5350 MHz:

Limits:

For OEM devices installed in vehicles, the maximum e.i.r.p. shall not exceed 30 mW or $1.76 + 10 \log_{10}B$, dBm, whichever is less. Devices shall implement TPC in order to have the capability to operate at least 3 dB below the maximum permitted e.i.r.p. of 30 mW.

Devices, other devices than installed in vehicles:

Maximum conducted Power: 250 mW (24 dBm) or $11 + 10 \log_{10} B$ [dBm], whichever power is less.

e.i.r.p.: 1.0 W (30 dBm) or $17 + 10 \log_{10} B$ [dBm], whichever power is less.

Outdoor fixed devices with a maximum e.i.r.p. greater than 200 mW shall comply with the following e.i.r.p. at different elevations, where θ is the angle above the local horizontal plane (of the Earth) as shown below:

- i. -13 dBW/MHz for $0^\circ \leq \theta < 8^\circ$
- ii. $-13 - 0.716 (\theta - 8)$ dBW/MHz for $8^\circ \leq \theta < 40^\circ$
- iii. $-35.9 - 1.22 (\theta - 40)$ dBW/MHz for $40^\circ \leq \theta \leq 45^\circ$
- iv. -42 dBW/MHz for $\theta > 45^\circ$

RSS-247, 6.2.3.1, Bands 5470-5600 MHz and 5650-5725 MHz:

Limits:

Maximum conducted Power: 250 mW (24 dBm) or $11 + 10 \log_{10} B$ [dBm], whichever power is less.

e.i.r.p.: 1.0 W (30 dBm) or $17 + 10 \log_{10} B$ [dBm], whichever power is less.

Note: Devices with a maximum e.i.r.p. greater than 500 mW shall implement TPC in order to have the capability to operate at least 6 dB below the maximum permitted e.i.r.p. of 1 W.

RSS-247, 6.2.4.1, Band 5725-5850 MHz:

Limits:

Maximum conducted Power: 1 W (30 dBm)

e.i.r.p.: 4 W (36 dBm)

5.1.3 TEST PROTOCOL

Ambient temperature: 24 °C
 Air Pressure: 1003 hPa
 Humidity: 45 %

WLAN a-Mode; 20 MHz; 6 Mbit/s

U-NII-band	Ch. No.	TX Freq. [MHz]	Cond. Power [dBm]	EIRP [dBm]	FCC Cond. Limit [dBm]	Margin [dB]	FCC EIRP Limit [dBm]	Margin [dB]	ISED Cond. Limit [dBm]	Margin [dB]	ISED EIRP Limit [dBm]	Margin [dB]	
1	36	5180	14.2	19.5	24.0	9.8	21.0	1.5	N/A	-	22.2	2.7	1)
	40	5200	14.4	19.7	24.0	9.6	21.0	1.3	N/A	-	22.2	2.5	1)
	48	5240	14.3	19.6	24.0	9.7	21.0	1.4	N/A	-	22.2	2.6	1)
2A	52	5260	14.3	19.6	24.0	9.7	30.0	10.4	23.2	8.9	29.2	9.6	1)
	60	5300	14.5	19.8	24.0	9.5	30.0	10.2	23.2	8.7	29.2	9.4	1)
	64	5320	13.5	18.8	24.0	10.5	30.0	11.2	23.2	9.7	29.2	10.4	1)
2C	100	5500	13.1	18.4	24.0	10.9	30.0	11.6	23.2	10.1	29.2	10.8	
	116	5580	15.2	20.5	24.0	8.8	30.0	9.5	23.2	8.0	29.2	8.7	
	140	5700	11.4	16.7	24.0	12.6	30.0	13.3	23.2	11.8	29.2	12.5	
3	149	5745	13.5	18.8	30.0	16.5	36.0	17.2	30.0	16.5	36.0	17.2	
	157	5785	14.4	19.7	30.0	15.6	36.0	16.3	30.0	15.6	36.0	16.3	
	165	5825	15.2	20.5	30.0	14.8	36.0	15.5	30.0	14.8	36.0	15.5	

WLAN n-Mode; 20 MHz; MCS 0; SISO

U-NII-band	Ch. No.	TX Freq. [MHz]	Cond. Power [dBm]	EIRP [dBm]	FCC Cond. Limit [dBm]	Margin [dB]	FCC EIRP Limit [dBm]	Margin [dB]	ISED Cond. Limit [dBm]	Margin [dB]	ISED EIRP Limit [dBm]	Margin [dB]	
1	36	5180	13.5	18.8	24.0	10.5	21.0	2.2	N/A	-	22.5	3.7	1)
	40	5200	13.6	18.9	24.0	10.4	21.0	2.1	N/A	-	22.5	3.6	1)
	48	5240	13.5	18.8	24.0	10.5	21.0	2.2	N/A	-	22.5	3.7	1)
2A	52	5260	13.6	18.9	24.0	10.4	30.0	11.1	23.5	9.9	23.0	4.1	1)
	60	5300	13.7	19.0	24.0	10.3	30.0	11.0	23.5	9.8	23.0	4.0	1)
	64	5320	12.7	18.0	24.0	11.3	30.0	12.0	23.5	10.8	23.0	5.0	1)
2C	100	5500	12.3	17.6	24.0	11.7	30.0	12.4	23.5	11.2	29.5	11.9	
	116	5580	13.4	18.7	24.0	10.6	30.0	11.3	23.5	10.1	29.5	10.8	
	140	5700	11.6	16.9	24.0	12.4	30.0	13.1	23.5	11.9	29.5	12.6	
3	149	5745	13.6	18.9	30.0	16.4	36.0	17.1	30.0	16.4	36.0	17.1	
	157	5785	13.6	18.9	30.0	16.4	36.0	17.1	30.0	16.4	36.0	17.1	
	165	5825	13.4	18.7	30.0	16.6	36.0	17.3	30.0	16.6	36.0	17.3	

WLAN n-Mode; 40 MHz; MCS 0; SISO

U-NII-band	Ch. No.	TX Freq. [MHz]	Cond. Power [dBm]	EIRP [dBm]	FCC Cond. Limit [dBm]	Margin [dB]	FCC EIRP Limit [dBm]	Margin [dB]	ISED Cond. Limit [dBm]	Margin [dB]	ISED EIRP Limit [dBm]	Margin [dB]	
1	38	5190	11.5	16.8	24.0	12.5	21.0	4.2	N/A	-	23.0	6.2	1)
	46	5230	13.5	18.8	24.0	10.5	21.0	2.2	N/A	-	23.0	4.2	1)
2A	54	5270	13.5	18.8	24.0	10.5	30.0	11.2	24.0	10.5	23.0	4.2	1)
	62	5310	11.6	16.9	24.0	12.4	30.0	13.1	24.0	12.4	23.0	6.1	1)
2C	102	5510	10.2	15.5	24.0	13.8	30.0	14.5	24.0	13.8	30.0	14.5	
	110	5550	13.2	18.5	24.0	10.8	30.0	11.5	24.0	10.8	30.0	11.5	
	134	5670	10.4	15.7	24.0	13.6	30.0	14.3	24.0	13.6	30.0	14.3	
3	151	5755	13.6	18.9	30.0	16.4	36.0	17.1	30.0	16.4	36.0	17.1	
	159	5795	13.5	18.8	30.0	16.5	36.0	17.2	30.0	16.5	36.0	17.2	

Remark: Power Meter measurement, no plots provided.

5.1.4 TEST EQUIPMENT USED

- R&S TS8997

5.2 UNDESIRABLE EMISSIONS; GENERAL FIELD STRENGTH LIMITS

Standard **FCC Part 15 Subpart E**

The test was performed according to:

ANSI C63.10, chapter 6.4, 6.5, 6.6.5

5.2.1 TEST DESCRIPTION

The test set-up was made in accordance to the general provisions of ANSI C63.10 in a typical installation configuration. The measurements were performed according the following sub-chapters of ANSI C63.10:

- < 30 MHz: Chapter 6.4
- 30 MHz – 1 GHz: Chapter 6.5
- > 1 GHz: Chapter 6.6 (procedure according 6.6.5 used)

The measurement procedure is implemented into the EMI test software EMC32 from R&S. Exploratory tests are performed at 3 orthogonal axes to determine the worst-case orientation of a body-worn or handheld EUT. The final test on all kind of EUTs is also performed at 3 axes. A pre-check is performed while the EUT is powered.

Below 1 GHz:

The Equipment Under Test (EUT) was set up on a non-conductive table in the semi-anechoic chamber. The influence of the EUT support table that is used between 30–1000 MHz was evaluated.

1. Measurement up to 30 MHz

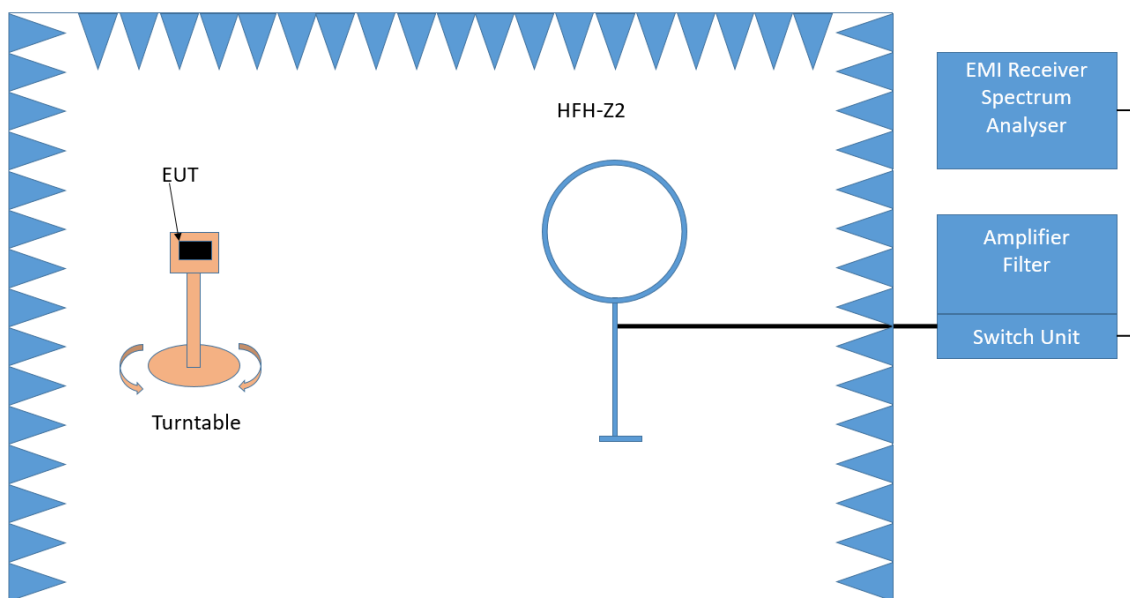

Test Setup; Spurious Emission Radiated (SAC), 9 kHz – 30 MHz

The Loop antenna HFH2-Z2 is used.

Step 1: pre measurement

- Anechoic chamber
- Antenna distance: 3 m

- Detector: Peak-Maxhold
- Frequency range: 0.009 - 0.15 MHz and 0.15 - 30 MHz
- Frequency steps: 0.05 kHz and 2.25 kHz
- IF-Bandwidth: 0.2 kHz and 9 kHz
- Measuring time / Frequency step: 100 ms (FFT-based)

Intention of this step is, to determine the radiated EMI-profile of the EUT. Afterwards the relevant emissions for the final measurement are identified.

Step 2: final measurement

For the relevant emissions determined in step 1, an additional measurement with the following settings will be performed. Intention of this step is to find the maximum emission level.

- Open area test site
- Antenna distance: according to the Standard
- Detector: Quasi-Peak
- Frequency range: 0.009 - 30 MHz
- Frequency steps: measurement at frequencies detected in step 1
- IF-Bandwidth: 0.2 - 10 kHz
- Measuring time / Frequency step: 1 s

2. Measurement above 30 MHz and up to 1 GHz

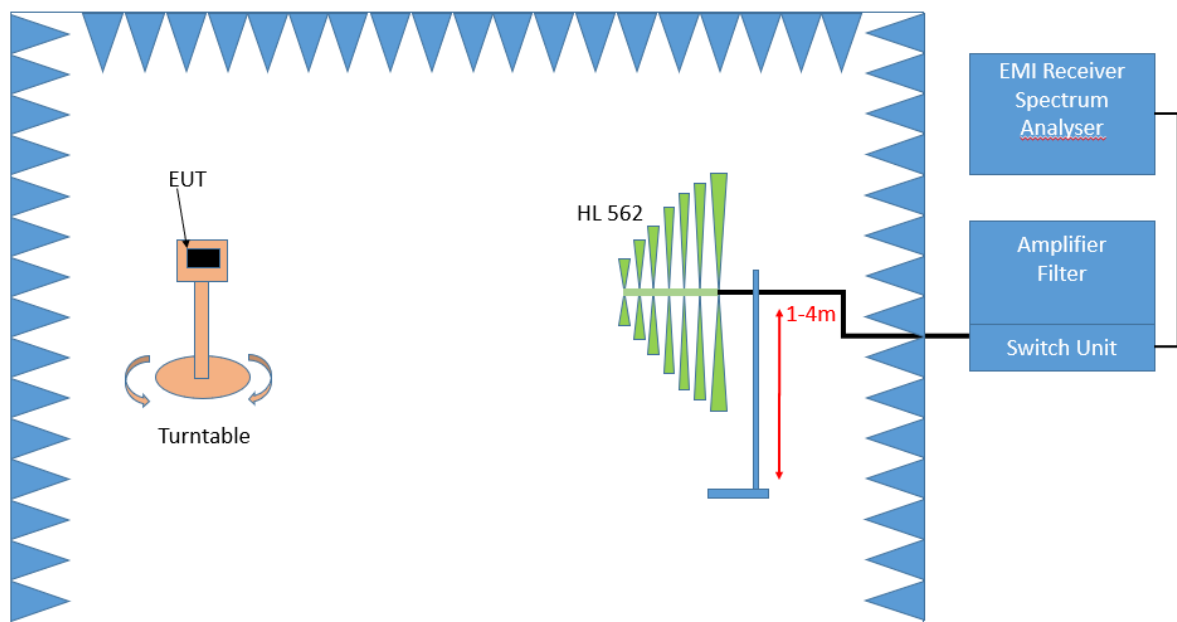

Test Setup; Spurious Emission Radiated (SAC), 30 MHz- 1GHz

Step 1: Preliminary scan

This is a preliminary test to identify the highest amplitudes relative to the limit.

Settings for step 1:

- Antenna distance: 3 m
- Detector: Peak-Maxhold / Quasipeak (FFT-based)
- Frequency range: 30 - 1000 MHz
- Frequency steps: 30 kHz
- IF-Bandwidth: 120 kHz
- Measuring time / Frequency step: 100 ms
- Turntable angle range: -180° to 90°
- Turntable step size: 90°
- Height variation range: 1 - 4 m
- Height variation step size: 1.5 m

- Polarisation: Horizontal + Vertical

Intention of this step is, to determine the radiated EMI-profile of the EUT. Afterwards the relevant emissions for the final measurement are identified.

Step 2: Adjustment measurement

In this step the accuracy of the turntable azimuth and antenna height will be improved. This is necessary to find out the maximum value of every frequency.

For each frequency, which was determined the turntable azimuth and antenna height will be adjusted. The turntable azimuth will slowly vary by 360°. During this action, the value of emission is continuously measured. The turntable azimuth at the highest emission will be recorded and adjusted. In this position, the antenna height will also slowly vary by 1 – 4 meter. During this action, the value of emission is also continuously measured. The antenna height of the highest emission will also be recorded and adjusted.

- Detector: Peak – Maxhold
- Measured frequencies: in step 1 determined frequencies
- IF – Bandwidth: 120 kHz
- Measuring time: 100 ms
- Turntable angle range: 360 °
- Height variation range: 1 – 4 m
- Antenna Polarisation: max. value determined in step 1

Step 3: Final measurement with QP detector

With the settings determined in step 2, the final measurement will be performed:

EMI receiver settings for step 3:

- Detector: Quasi-Peak (< 1 GHz)
- Measured frequencies: in step 1 determined frequencies
- IF – Bandwidth: 120 kHz
- Measuring time: 1 s

After the measurement a plot will be generated which contains a diagram with the results of the preliminary scan and a chart with the frequencies and values of the results of the final measurement.

Above 1 GHz:

The Equipment Under Test (EUT) was set up on a non-conductive support (tilt device) at 1.5 m height in the fully-anechoic chamber.

All steps were performed with one height (1.5 m) of the receiving antenna only.

3. Measurement 1 GHz up to 26.5 GHz

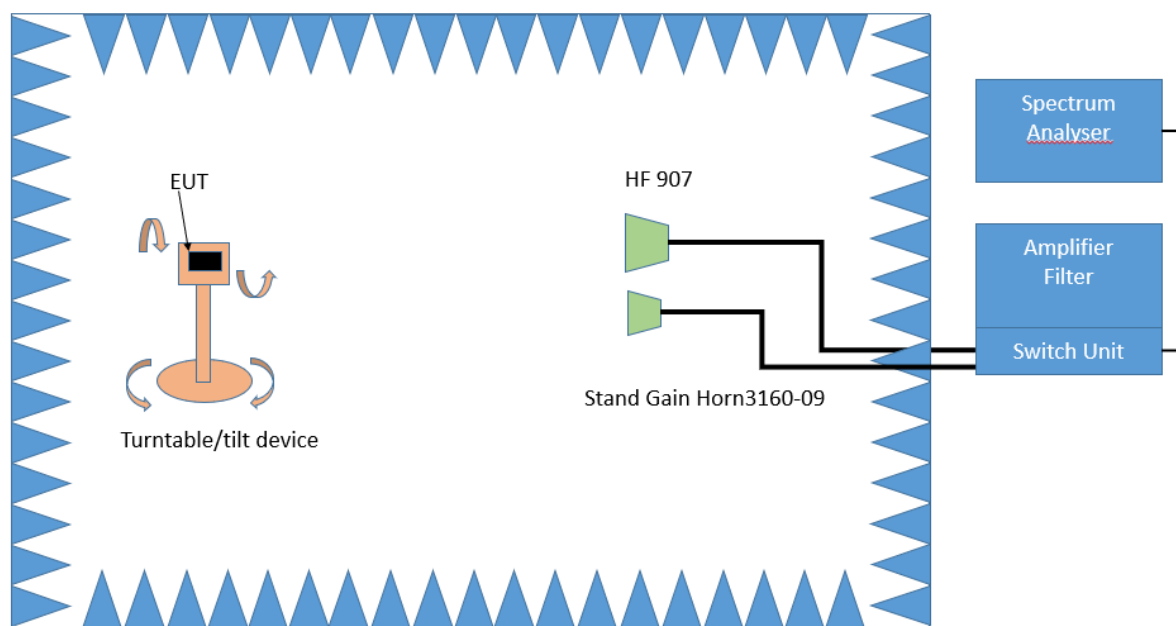

Test Setup; Spurious Emission Radiated (FAC), 1 GHz-26.5 GHz

Step 1:

The Equipment Under Test (EUT) was set up on a non-conductive support (tilt device) at 1.5 m height in the fully-anechoic chamber.

All steps were performed with one height (1.5 m) of the receiving antenna only.

The EUT is turned during the preliminary measurement across the elevation axis, with a step size of 90 °.

The turn table step size (azimuth angle) for the preliminary measurement is 45 °.

Step 2:

Due to the fact, that in this frequency range the test is performed in a fully anechoic room, the height scan of the receiving antenna instep 2 is omitted. Instead of this, a maximum search with a step size $\pm 45^\circ$ for the elevation axis is performed.

The turn table azimuth will slowly vary by $\pm 22.5^\circ$.

The elevation angle will slowly vary by $\pm 45^\circ$

EMI receiver settings (for all steps):

- Detector: Peak, Average
- IF Bandwidth = 1 MHz

Step 3:

Spectrum analyser settings for step 3:

- Detector: Peak / Average
- Measured frequencies: in step 1 determined frequencies
- IF – Bandwidth: 1 MHz
- Measuring time: 1 s

4. Measurement above 26.5 GHz up to 40 GHz

The following modifications, compared to the frequency range 1 GHz – 26.5 GHz, apply to the measurement procedure for the frequency range above 26.5 GHz:

- Measurement distance: 1m

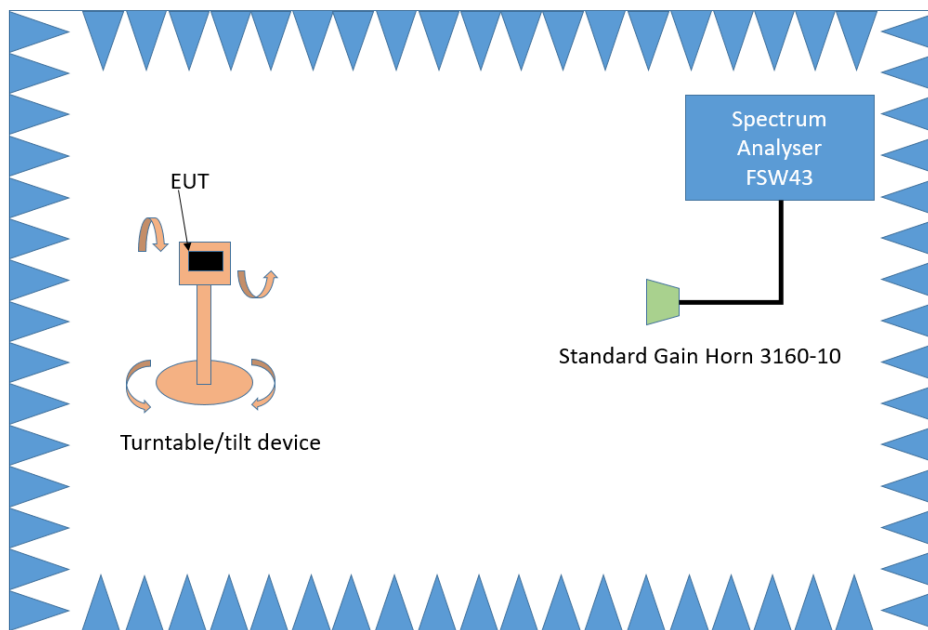

Test Setup; Spurious Emission Radiated (FAC), 26.5 – 40 GHz

5.2.2 TEST REQUIREMENTS / LIMITS

A) FCC

FCC Part 15 Subpart E, §15.407 (b)(1)

For transmitters operating in the 5150–5250 MHz band:

Limit: –27 dBm/MHz EIRP outside of the band 5150–5350 MHz.

FCC Part 15 Subpart E, §15.407 (b)(2)

For transmitters operating in the 5250–5350 MHz band:

Limit: –27 dBm/MHz EIRP outside of the band 5150–5350 MHz.

FCC Part 15 Subpart E, §15.407 (b)(3)

For transmitters operating in the 5470–5725 MHz band:

Limit: –27 dBm/MHz EIRP outside of the band 5470–5725 MHz.

FCC Part 15 Subpart E, §15.407 (b)(4)

For transmitters operating in the 5725–5850 MHz band:

Limit: –27 dBm/MHz at 75 MHz or more above or below the band edge
 increasing linearly to 10 dBm/MHz at 25 MHz above or below the band edge
 increasing linearly to 15.6 dBm/MHz at 5 MHz above or below the band edge
 increasing linearly to 27 dBm/MHz at the band edge.

FCC Part 15 Subpart E, §15.407 (b) (5)

For transmitters operating within the 5.925-7.125 GHz band:

Limit: -27 dBm/MHz EIRP outside of the band 5.925-7.125 GHz.

FCC Part 15 Subpart E, §15.407 (b) (6)

For transmitters operating within the 5.925-7.125 GHz bands:

Power spectral density must be suppressed by 20 dB at 1 MHz outside of channel edge, by 28 dB at one channel bandwidth from the channel center, and by 40 dB at one- and one-half times the channel bandwidth away from channel center. At frequencies between one megahertz outside an unlicensed device's channel edge and one channel bandwidth from the center of the channel, the limits must be linearly interpolated between 20 dB and 28 dB suppression, and at frequencies between one and one- and one-half times an unlicensed device's channel bandwidth, the limits must be linearly interpolated between 28 dB and 40 dB suppression. Emissions removed from the channel center by more than one- and one-half times the channel bandwidth must be suppressed by at least 40 dB.

B) IC

Different frequency bands and limits apply, as compared to the FCC requirements.

RSS-247, 6.2.1.2, Emissions outside the band 5150-5250 MHz, indoor operation only:

Limit: -27 dBm/MHz EIRP outside of the band 5150-5250 MHz.

RSS-247, 6.2.2.2, Emissions outside the band 5250-5350 MHz:

Limit: -27 dBm/MHz EIRP outside of the band 5250-5350 MHz.

RSS-247, 6.2.3.2, Emissions outside the bands 5470-5600 MHz and 5650-5725 MHz:

Limit: -27 dBm/MHz EIRP outside of the band 5470-5725 MHz.

However, devices with bandwidth overlapping the band edge of 5725 MHz can meet the emission limit of -27 dBm/MHz e.i.r.p. at 5850 MHz instead of 5725 MHz.

Note: No operation is permitted for the frequency range 5600-5650 MHz.

RSS-247, 6.2.4.2, Emissions outside the band 5725-5850 MHz:

- a. 27 dBm/MHz at frequencies from the band edges decreasing linearly to 15.6 Bm/MHz at 5 MHz above or below the band edges;
- b. 15.6 dBm/MHz at 5 MHz above or below the band edges decreasing linearly to 10 dBm/MHz at 25 MHz above or below the band edges;
- c. 10 dBm/MHz at 25 MHz above or below the band edges decreasing linearly to -27 dBm/MHz at 75 MHz above or below the band edges; and
- d. -27 dBm/MHz at frequencies more than 75 MHz above or below the band edges.

C) FCC & IC

FCC Part 15 Subpart E, §15.405

The provisions of §§ 15.203 and 15.205 are included.

§15.407 (b)(6)

Unwanted emissions below 1 GHz must comply with the general field strength limits set forth in § 15.209.

§15.407 (b)(7)

The provisions of §15.205 apply to intentional radiators operating under this section

FCC Part 15, Subpart C, §15.209, Radiated Emission Limits

Frequency in MHz	Limit (µV/m)	Measurement distance (m)	Limits (dBµV/m)
0.009 – 0.49	2400/F(kHz)@300m	3	(48.5 – 13.8)@300m
0.49 – 1.705	24000/F(kHz)@30m	3	(33.8 – 23.0)@30m
1.705 – 30	30@30m	3	29.5@30m

The measured values are corrected with an inverse linear distance extrapolation factor (40 dB/decade) according FCC 15.31 (2).

Frequency in MHz	Limit (µV/m)	Measurement distance (m)	Limits (dBµV/m)
30 – 88	100@3m	3	40.0@3m
88 – 216	150@3m	3	43.5@3m
216 – 960	200@3m	3	46.0@3m
960 - 26000	500@3m	3	54.0@3m
26000 - 40000	500@3m	1	54.0@3m

The measured values above 26 GHz are corrected with an inverse linear distance extrapolation factor (20 dB/decade).

§15.35(b) ..., there is also a limit on the radio frequency emissions, as measured using instrumentation with a peak detector function, corresponding to 20 dB above the maximum permitted average limit....

Used conversion factor:

- Limit (dBµV/m) = 20 log (Limit (µV/m)/1µV/m)
- Limit (dBµV/m) = EIRP [dBm] – 20 log (d [m]) + 104.8

Limit types (in result tables):

RB – Emissions falls into a "Restricted Band" according FCC §§15.205 and 15.209 *)

UE – "Undesirable Emission Limit" according FCC §15.407

BE-RB – Band Edge Limit basing on "Restricted Band Limits"

BE-UE – Band Edge Limit basing on "Undesirable Emission Limit"

*) Below 1 GHz the limits of §15.209 are applied for all frequencies.

5.2.3 TEST PROTOCOL

Ambient temperature: 27 - 31 °C
 Air Pressure: 1006 - 1011 hPa
 Humidity: 38 - 47 %
 WLAN a-Mode; 20 MHz; 6 Mbit/s
 Applied duty cycle correction (AV): 0 dB

Antenna	Ch. Center Freq. [MHz]	Spurious Freq. [MHz]	Spurious Level [dBµV/m]	Detector	RBW [kHz]	Limit [dBµV/m]	Margin [dB]	Limit Type
Taoglas	5200	480.0	20.0	QP	120	46.0	26.0	RB
Taoglas	5200	850.7	19.4	QP	120	46.0	26.6	RB
Molex	5200	650.0	30.2	QP	120	46.0	15.8	RB
Molex	5200	10399.4	62.1	PEAK	1000	68.2	6.1	UE
Molex	5260	10519.3	63.3	PEAK	1000	68.2	4.9	UE
Taoglas	5200	5053.5	71.6	PEAK	1000	74.0	2.4	RB
Taoglas	5200	5053.5	50.4	AV	1000	54.0	3.6	RB
Taoglas	5200	10400.6	54.8	PEAK	1000	68.2	13.4	UE
Molex	5580	11160.3	55.9	PEAK	1000	74.0	18.1	RB
Molex	5580	11160.3	42.1	AV	1000	54.0	11.9	RB
Molex	5825	11649.7	60.8	PEAK	1000	74.0	13.2	RB
Molex	5825	11649.7	47.5	AV	1000	54.0	6.5	RB
Taoglas	5260	10518.9	60.5	PEAK	1000	68.2	7.7	UE
Taoglas	5580	11160.3	63.0	PEAK	1000	74.0	11.0	RB
Taoglas	5580	11160.3	49.6	AV	1000	54.0	4.4	RB
Taoglas	5825	11649.0	65.0	PEAK	1000	74.0	9.0	RB
Taoglas	5825	11649.0	51.1	AV	1000	54.0	2.9	RB

WLAN n-Mode; 40 MHz; MCS 0; SISO
 Applied duty cycle correction (AV): 0 dB

Antenna	Ch. Center Freq. [MHz]	Spurious Freq. [MHz]	Spurious Level [dBµV/m]	Detector	RBW [kHz]	Limit [dBµV/m]	Margin [dB]	Limit Type
Taoglas	5510	-	-	-	-	-	-	-

Remark: Please see next sub-clause for the measurement plot.

5.2.4 MEASUREMENT PLOTS

Radio Technology = WLAN a, Operating Frequency = mid, Measurement range = 9kHz - 30MHz, Subband = U-NII-1 (S02_161_AG01)

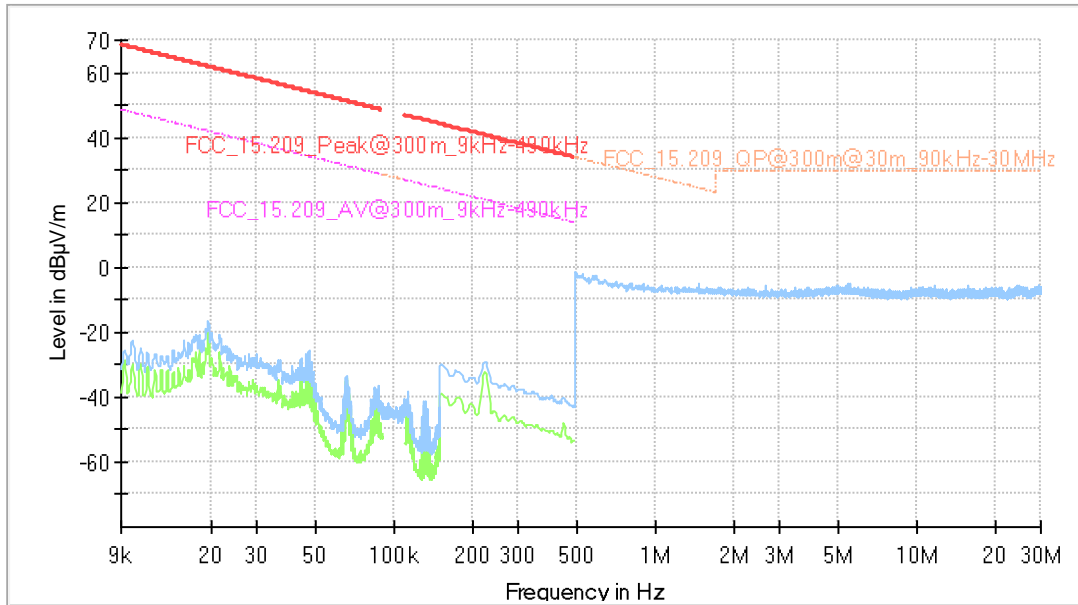

Final Result

Frequency (MHz)	MaxPeak (dBµV/m)	Average (dBµV/m)	Limit (dBµV/m)	Margin (dB)	Meas. Time (ms)	Bandwidth (kHz)	Height (cm)	Azimuth (deg)	Corr. (dB/m)
---	---	---	---	---	---	---	---	---	---

Radio Technology = WLAN a, Operating Frequency = mid, Measurement range = 9kHz - 30MHz, Subband = U-NII-1 (S03_161_AG01)

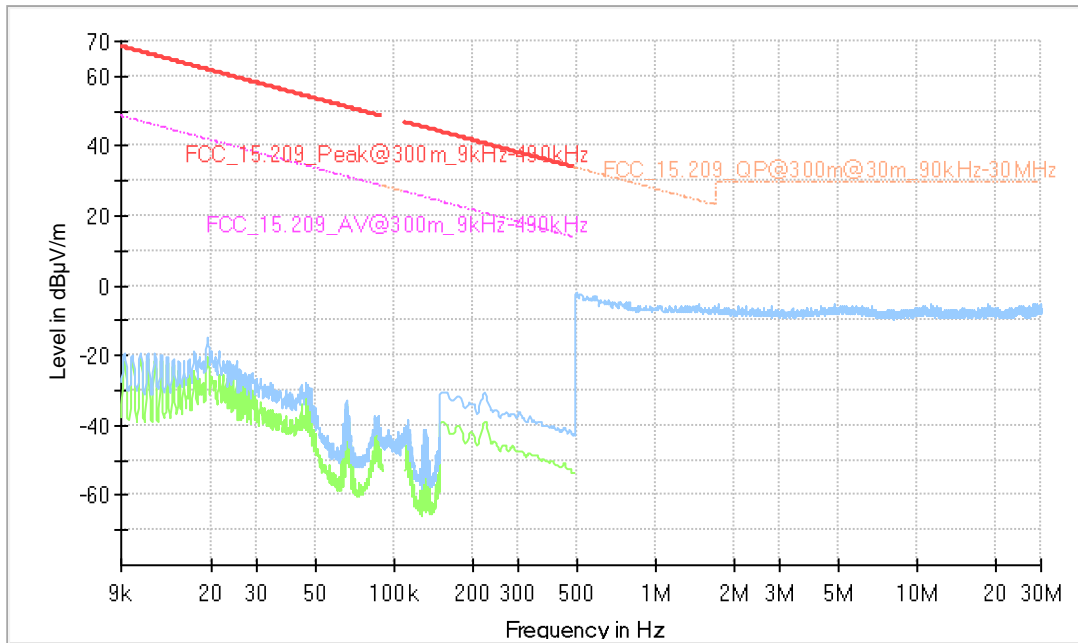

Final Result

Frequency (MHz)	MaxPeak (dBµV/m)	Average (dBµV/m)	Limit (dBµV/m)	Margin (dB)	Meas. Time (ms)	Bandwidth (kHz)	Height (cm)	Azimuth (deg)	Corr. (dB/m)
---	---	---	---	---	---	---	---	---	---

Radio Technology = WLAN a, Operating Frequency = mid, Measurement range = 30MHz - 1GHz, Subband = U-NII-1 (S03_161_AG01)

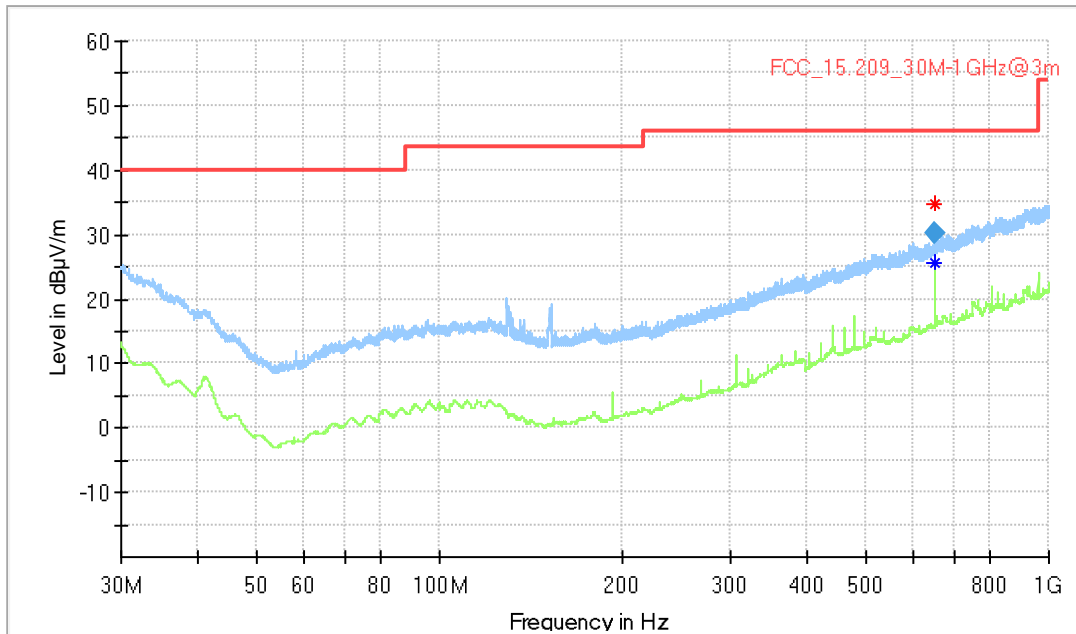

Final Result

Frequency (MHz)	QuasiPeak (dBµV/m)	Limit (dBµV/m)	Margin (dB)	Meas. Time (ms)	Bandwidth (kHz)	Height (cm)	Pol	Azimuth (deg)	Corr. (dB/m)
650.010000	30.23	46.00	15.77	1000.0	120.000	121.0	H	21.0	23.6

Radio Technology = WLAN a, Operating Frequency = mid, Measurement range = 1GHz - 26GHz, Subband = U-NII-1 (S03_161_AG01)

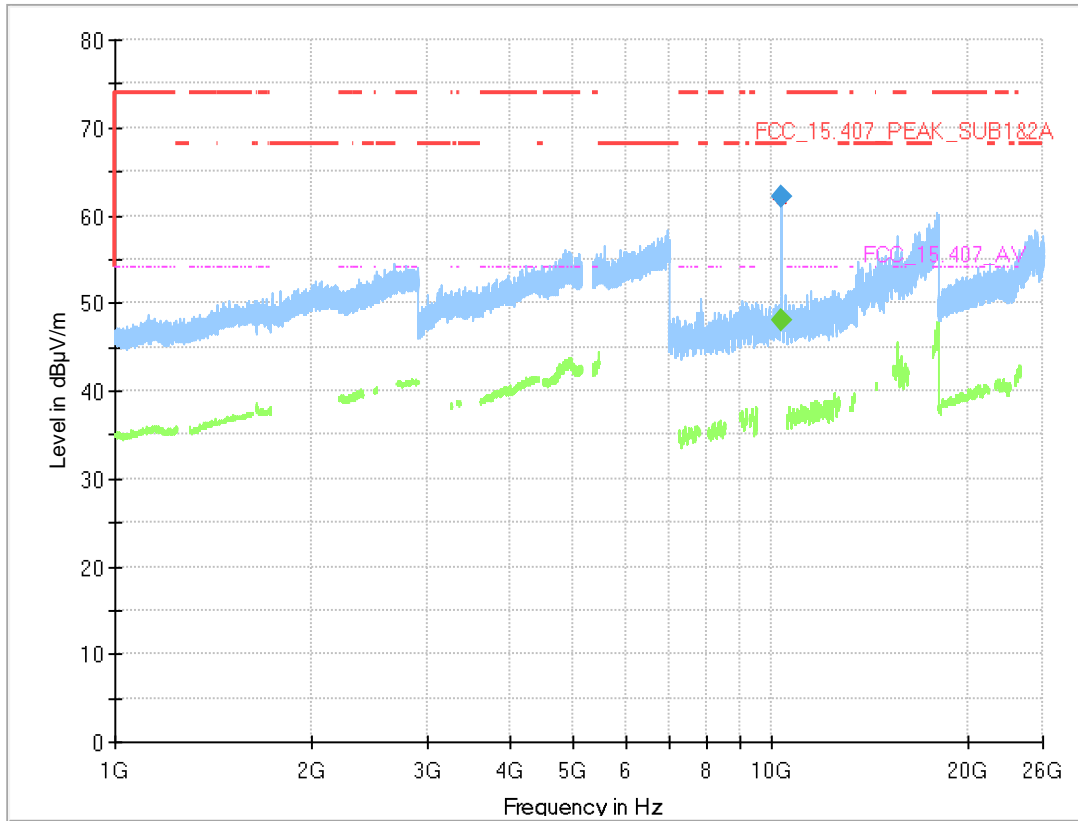

Final_Result

Frequency (MHz)	MaxPeak (dBµV/m)	CAverage (dBµV/m)	Limit (dBµV/m)	Margin (dB)	Meas. Time (ms)	Bandwidth (kHz)	Height (cm)	Pol	Azimuth (deg)	Elevation (deg)	Corr. (dB/m)
10399.388	---	48.0	---	---	1000.0	1000.000	150.0	H	56.0	82.0	-9.8
10399.388	62.1	---	68.20	6.11	1000.0	1000.000	150.0	H	56.0	82.0	-9.8

Radio Technology = WLAN a, Operating Frequency = low, Measurement range = 1GHz - 26GHz, Subband = U-NII-2A (S03_161_AG01)

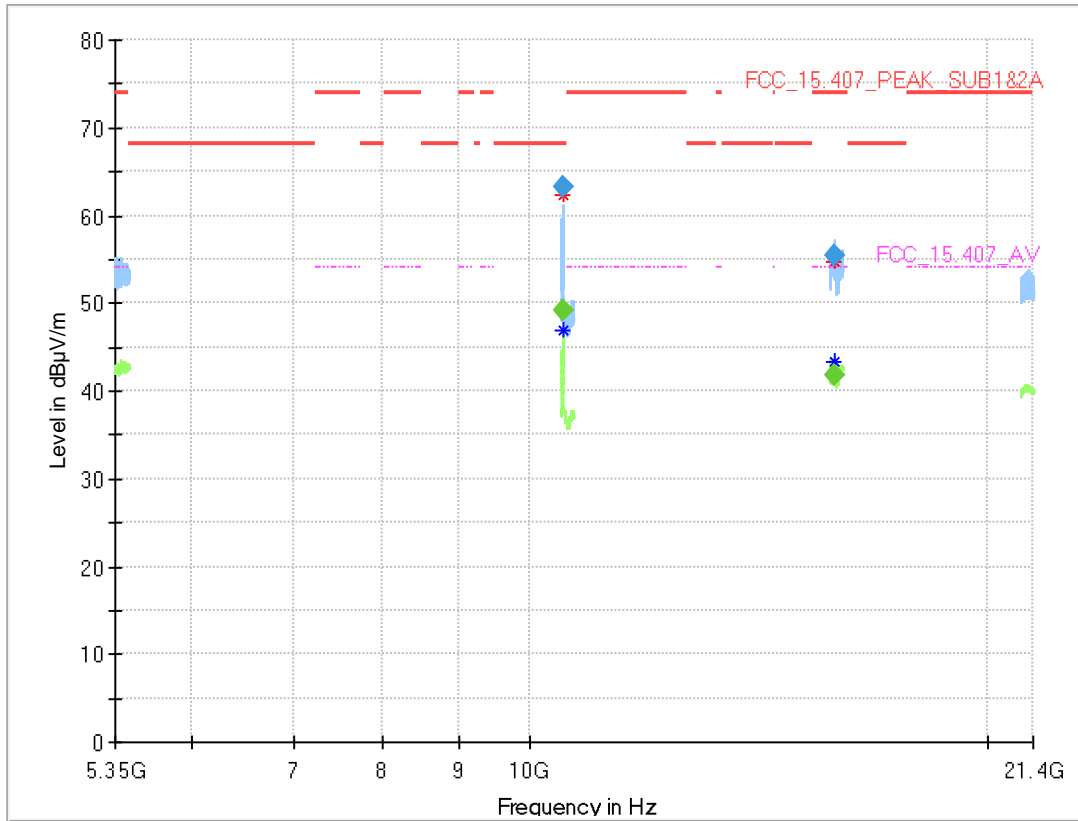

Final_Result

Frequency (MHz)	MaxPeak (dBµV/m)	CAverage (dBµV/m)	Limit (dBµV/m)	Margin (dB)	Meas. Time (ms)	Bandwidth (kHz)	Height (cm)	Pol	Azimuth (deg)	Elevation (deg)	Corr. (dB/m)
10519.300	---	49.2	---	---	1000.0	1000.000	150.0	V	-188.0	-12.0	-8.9
10519.300	63.3	---	68.20	4.86	1000.0	1000.000	150.0	V	-188.0	-12.0	-8.9
15849.600	---	41.8	54.00	12.23	1000.0	1000.000	150.0	H	-144.0	102.0	0.6
15849.600	55.3	---	74.00	18.67	1000.0	1000.000	150.0	H	-144.0	102.0	0.6

Radio Technology = WLAN a, Operating Frequency = mid, Measurement range = 1GHz - 26GHz, Subband = U-NII-2C (S03_161_AG01)

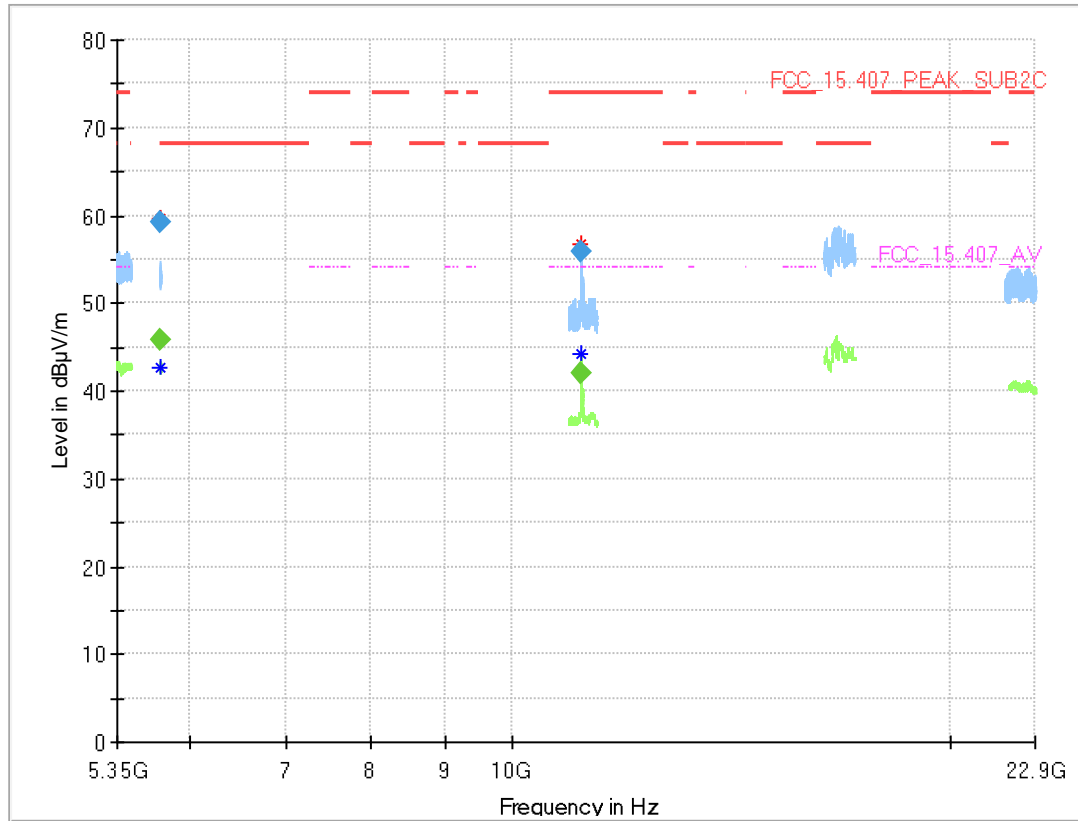

Final_Result

Frequency (MHz)	MaxPeak (dBµV/m)	CAverage (dBµV/m)	Limit (dBµV/m)	Margin (dB)	Meas. Time (ms)	Bandwidth (kHz)	Height (cm)	Pol	Azimuth (deg)	Elevation (deg)	Corr. (dB/m)
5726.050	---	45.8	---	---	1000.0	1000.000	150.0	H	-171.0	82.0	15.6
5726.050	59.2	---	68.20	9.01	1000.0	1000.000	150.0	H	-171.0	82.0	15.6
11160.320	---	42.1	54.00	11.94	1000.0	1000.000	150.0	H	2.0	87.0	-7.1
11160.320	55.9	---	74.00	18.15	1000.0	1000.000	150.0	H	2.0	87.0	-7.1

Radio Technology = WLAN a, Operating Frequency = high, Measurement range = 1GHz - 26GHz, Subband = U-NII-3 (S03_161_AG01)

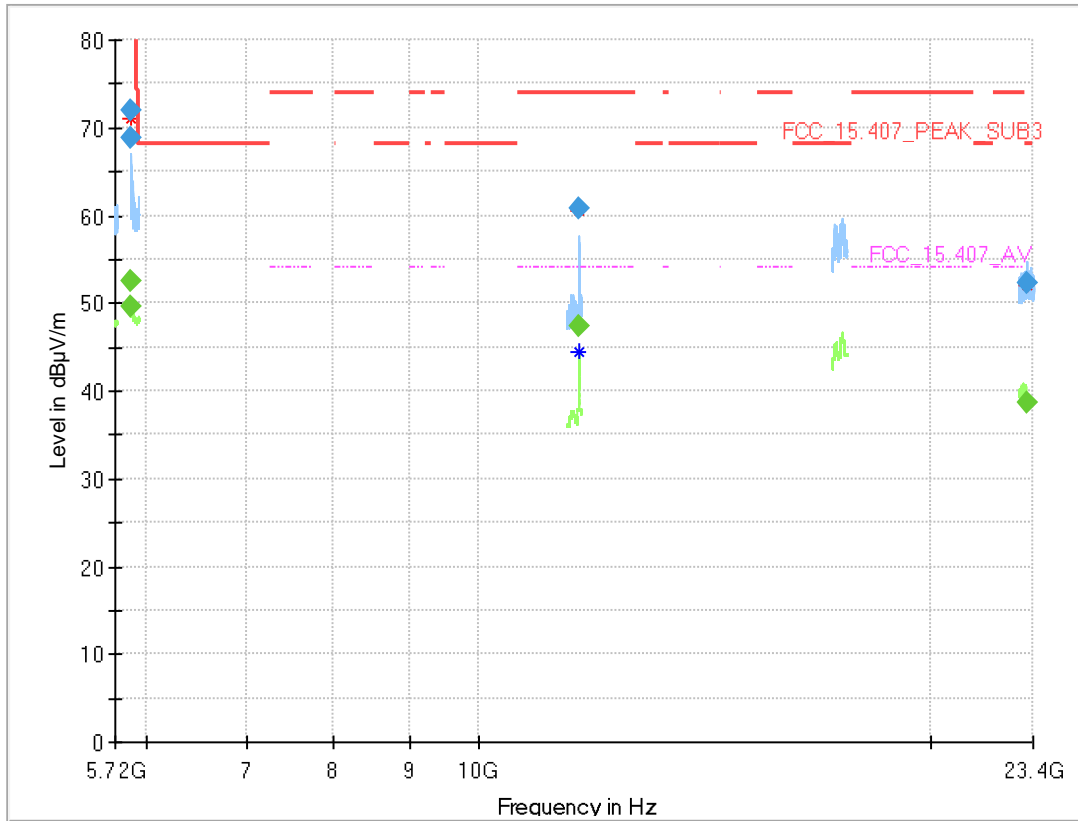

Final_Result

Frequency (MHz)	MaxPeak (dBµV/m)	CAverage (dBµV/m)	Limit (dBµV/m)	Margin (dB)	Meas. Time (ms)	Bandwidth (kHz)	Height (cm)	Pol	Azimuth (deg)	Elevation (deg)	Corr. (dB/m)
5850.000	---	52.5	---	---	1000.0	1000.000	150.0	H	-9.0	15.0	15.8
5850.000	72.0	---	122.2	50.24	1000.0	1000.000	150.0	H	-9.0	15.0	15.8
5851.440	---	49.7	---	---	1000.0	1000.000	150.0	H	146.0	103.0	15.8
5851.440	68.8	---	118.9	50.10	1000.0	1000.000	150.0	H	146.0	103.0	15.8
11649.712	---	47.5	54.00	6.53	1000.0	1000.000	150.0	V	-185.0	-12.0	-6.5
11649.712	60.8	---	74.00	13.23	1000.0	1000.000	150.0	V	-185.0	-12.0	-6.5
23177.540	---	38.6	---	---	1000.0	1000.000	150.0	V	37.0	102.0	19.8
23177.540	52.3	---	68.20	15.88	1000.0	1000.000	150.0	V	37.0	102.0	19.8

Radio Technology = WLAN a, Operating Frequency = mid, Measurement range = 30MHz - 1GHz, Subband = U-NII-1 (S02_161_AG01)

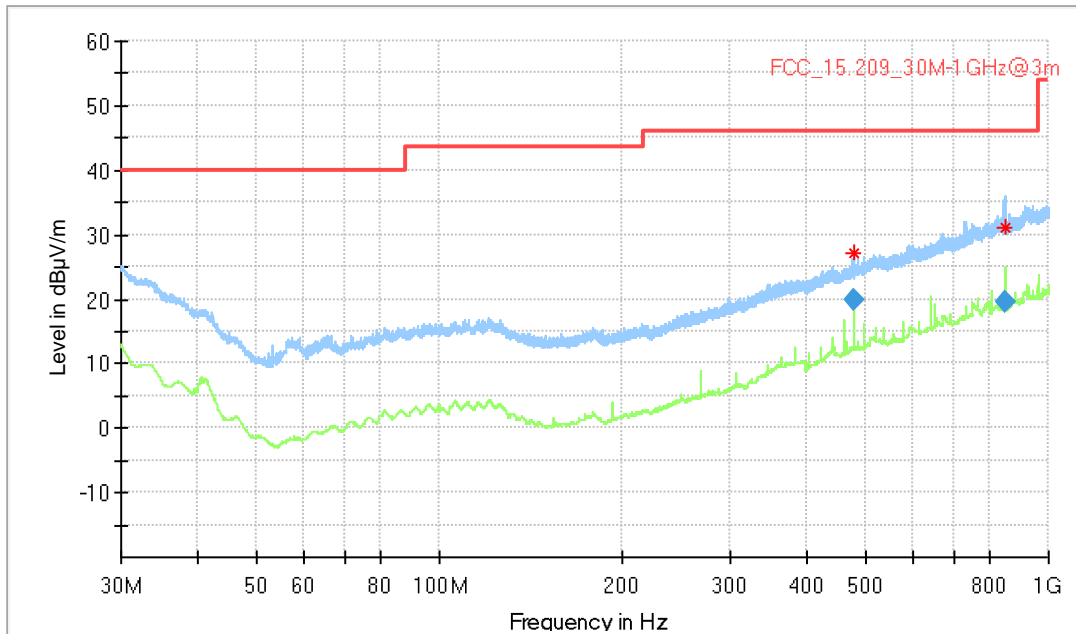

Final Result

Frequency (MHz)	QuasiPeak (dBµV/m)	Limit (dBµV/m)	Margin (dB)	Meas. Time (ms)	Bandwidth (kHz)	Height (cm)	Pol	Azimuth (deg)	Corr. (dB/m)
480.000000	19.99	46.00	26.01	1000.0	120.000	117.0	V	-2.0	20.1
850.740000	19.41	46.00	26.59	1000.0	120.000	114.0	V	17.0	26.7

Radio Technology = WLAN a, Operating Frequency = mid, Measurement range = 1GHz - 26GHz, Subband = U-NII-1 (S02_161_AG01)

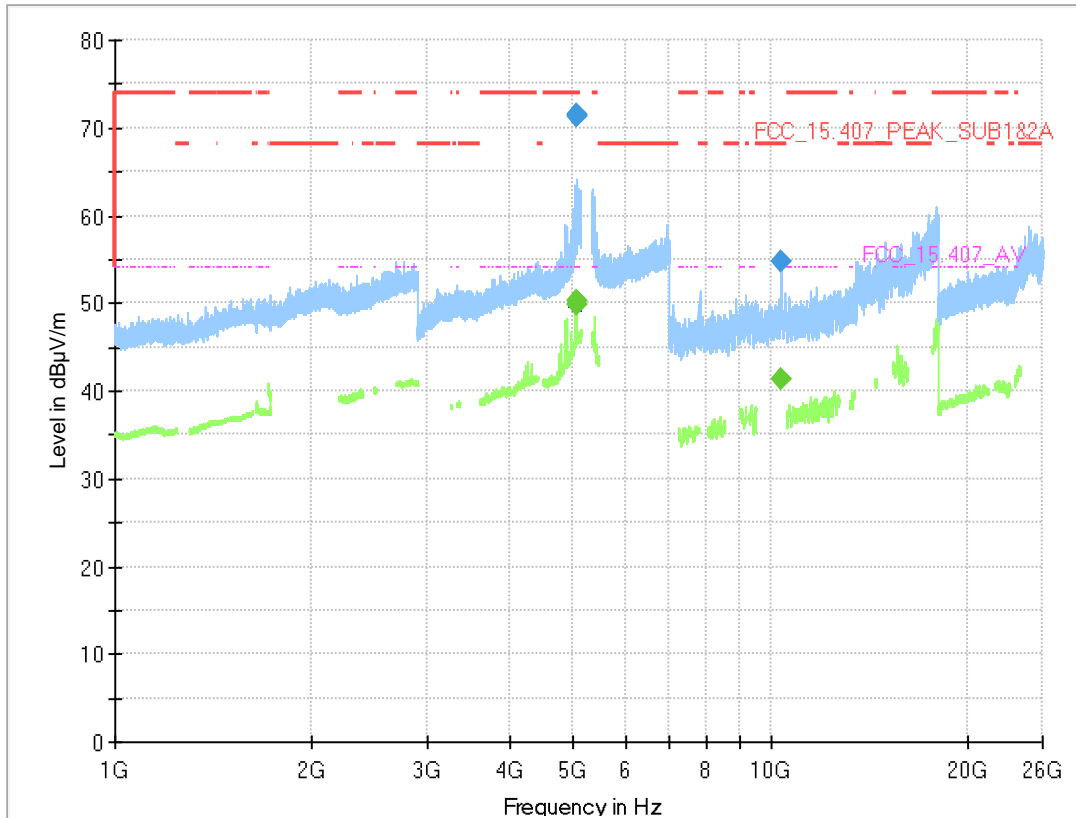

Final Result

Frequency (MHz)	MaxPeak (dBµV/m)	CAverage (dBµV/m)	Limit (dBµV/m)	Margin (dB)	Meas. Time (ms)	Bandwidth (kHz)	Height (cm)	Pol	Azimuth (deg)	Elevation (deg)	Corr. (dB/m)
5053.475	---	50.4	54.00	3.63	1000.0	1000.000	150.0	V	-134.0	-15.0	15.3
5053.475	71.6	---	74.00	2.41	1000.0	1000.000	150.0	V	-134.0	-15.0	15.3
5077.200	---	49.8	54.00	4.19	1000.0	1000.000	150.0	V	95.0	-8.0	15.3
5077.200	71.4	---	74.00	2.62	1000.0	1000.000	150.0	V	95.0	-8.0	15.3
10400.625	---	41.3	---	---	1000.0	1000.000	150.0	V	90.0	1.0	-9.8
10400.625	54.8	---	68.20	13.44	1000.0	1000.000	150.0	V	90.0	1.0	-9.8

Radio Technology = WLAN a, Operating Frequency = low, Measurement range = 1GHz - 26GHz, Subband = U-NII-2A (S02_161_AG01)

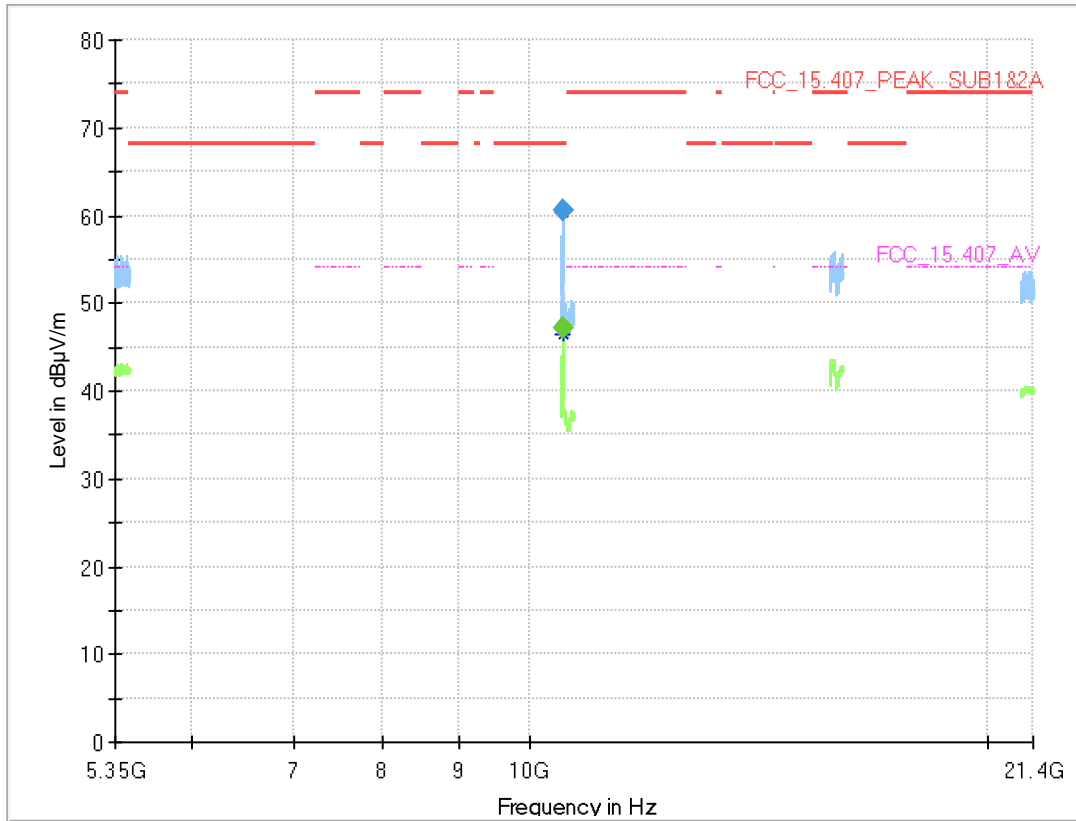

Final_Result

Frequency (MHz)	MaxPeak (dBµV/m)	CAverage (dBµV/m)	Limit (dBµV/m)	Margin (dB)	Meas. Time (ms)	Bandwidth (kHz)	Height (cm)	Pol	Azimuth (deg)	Elevation (deg)	Corr. (dB/m)
10518.900	---	47.2	---	---	1000.0	1000.000	150.0	H	52.0	105.0	-8.9
10518.900	60.5	---	68.20	7.67	1000.0	1000.000	150.0	H	52.0	105.0	-8.9

Radio Technology = WLAN a, Operating Frequency = mid, Measurement range = 1GHz - 26GHz, Subband = U-NII-2C (S02_161_AG01)

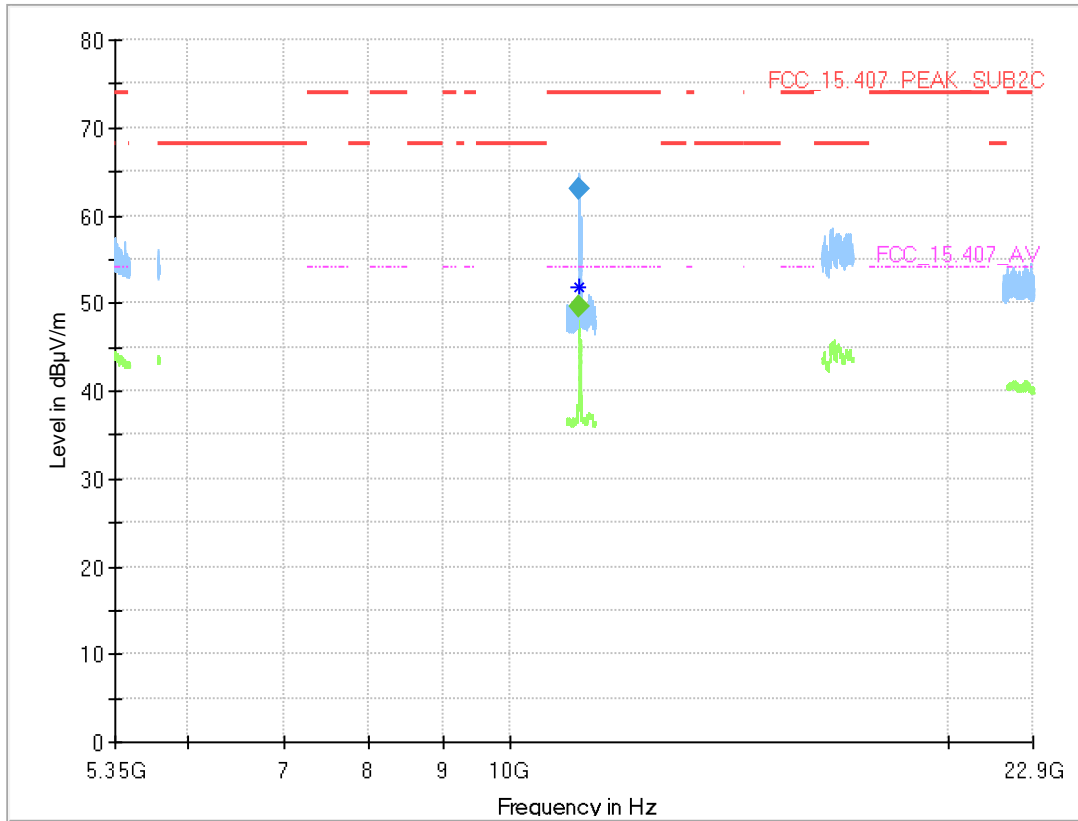

Final_Result

Frequency (MHz)	MaxPeak (dBµV/m)	CAverage (dBµV/m)	Limit (dBµV/m)	Margin (dB)	Meas. Time (ms)	Bandwidth (kHz)	Height (cm)	Pol	Azimuth (deg)	Elevation (deg)	Corr. (dB/m)
11160.320	---	49.6	54.00	4.40	1000.0	1000.000	150.0	H	42.0	78.0	-7.1
11160.320	63.0	---	74.00	11.03	1000.0	1000.000	150.0	H	42.0	78.0	-7.1

Radio Technology = WLAN a, Operating Frequency = high, Measurement range = 1GHz - 26GHz, Subband = U-NII-3 (S02_161_AG01)

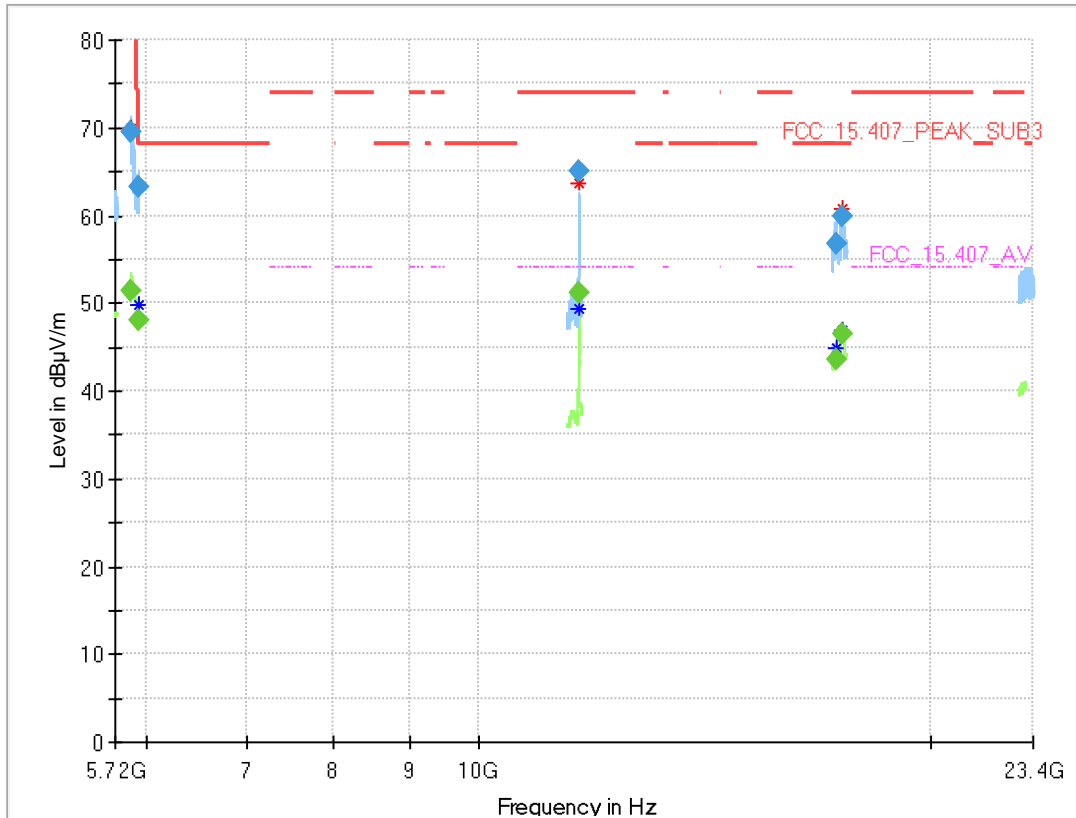

Final Result

Frequency (MHz)	MaxPeak (dBµV/m)	CAverage (dBµV/m)	Limit (dBµV/m)	Margin (dB)	Meas. Time (ms)	Bandwidth (kHz)	Height (cm)	Pol	Azimuth (deg)	Elevation (deg)	Corr. (dB/m)
5850.000	---	51.4	---	---	1000.0	1000.000	150.0	V	-188.0	-6.0	15.8
5850.000	69.5	---	122.2	52.73	1000.0	1000.000	150.0	V	-188.0	-6.0	15.8
5920.000	---	48.0	---	---	1000.0	1000.000	150.0	H	96.0	105.0	16.3
5920.000	63.2	---	71.90	8.74	1000.0	1000.000	150.0	H	96.0	105.0	16.3
11649.038	---	51.1	54.00	2.90	1000.0	1000.000	150.0	H	42.0	75.0	-6.5
11649.038	65.0	---	74.00	9.00	1000.0	1000.000	150.0	H	42.0	75.0	-6.5
17291.438	---	43.6	---	---	1000.0	1000.000	150.0	H	146.0	-10.0	0.9
17291.438	56.8	---	68.20	11.44	1000.0	1000.000	150.0	H	146.0	-10.0	0.9
17479.969	---	46.5	---	---	1000.0	1000.000	150.0	H	-56.0	86.0	1.5
17479.969	59.8	---	68.20	8.39	1000.0	1000.000	150.0	H	-56.0	86.0	1.5

Radio Technology = WLAN n 40 MHz, Operating Frequency = low, Measurement range = 1GHz - 26GHz, Subband = U-NII-2C (S02_161_AG01)

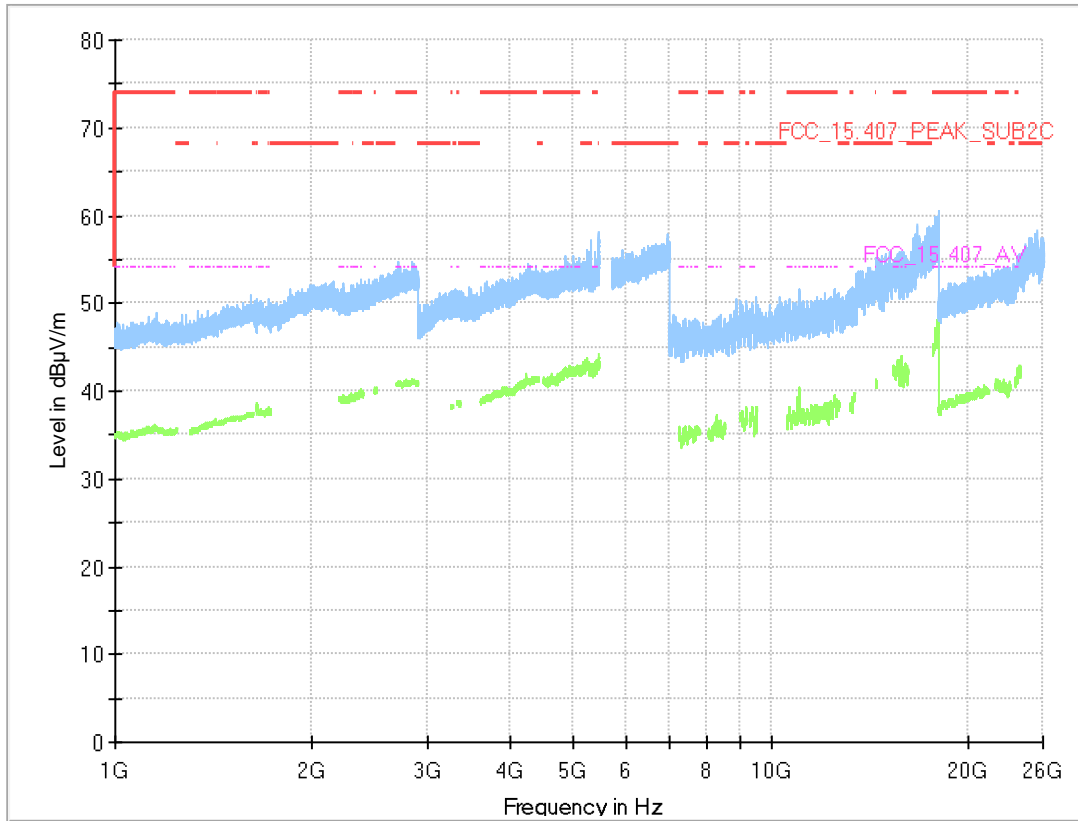

Final_Result

Frequency (MHz)	MaxPeak (dBµV/m)	CAverage (dBµV/m)	Limit (dBµV/m)	Margin (dB)	Meas. Time (ms)	Bandwidth (kHz)	Height (cm)	Pol	Azimuth (deg)	Elevation (deg)	Corr. (dB/m)
---	---	---	---	---	---	---	---	---	---	---	---

5.2.5 TEST EQUIPMENT USED

- Radiated Emissions SAC H-Field
- Radiated Emissions FAR 5 GHz FCC
- Radiated Emissions SAC up to 1 GHz

5.3 BAND EDGE

Standard **FCC Part 15 Subpart E**

The test was performed according to:

ANSI C63.10, chapter 6.6.5

5.3.1 TEST DESCRIPTION

The test set-up was made in accordance to the general provisions of ANSI C63.10 in a typical installation configuration. The measurements were performed according the following sub-chapter of ANSI C63.10:

- Chapter 6.10.5

The Equipment Under Test (EUT) was set up on a non-conductive support (tilt device) at 1.5 m height in the fully-anechoic chamber.

All steps were performed with one height (1.5 m) of the receiving antenna only (procedure according ANSI C63.10, chapter 6.6.5).

3. Measurement above 1 GHz

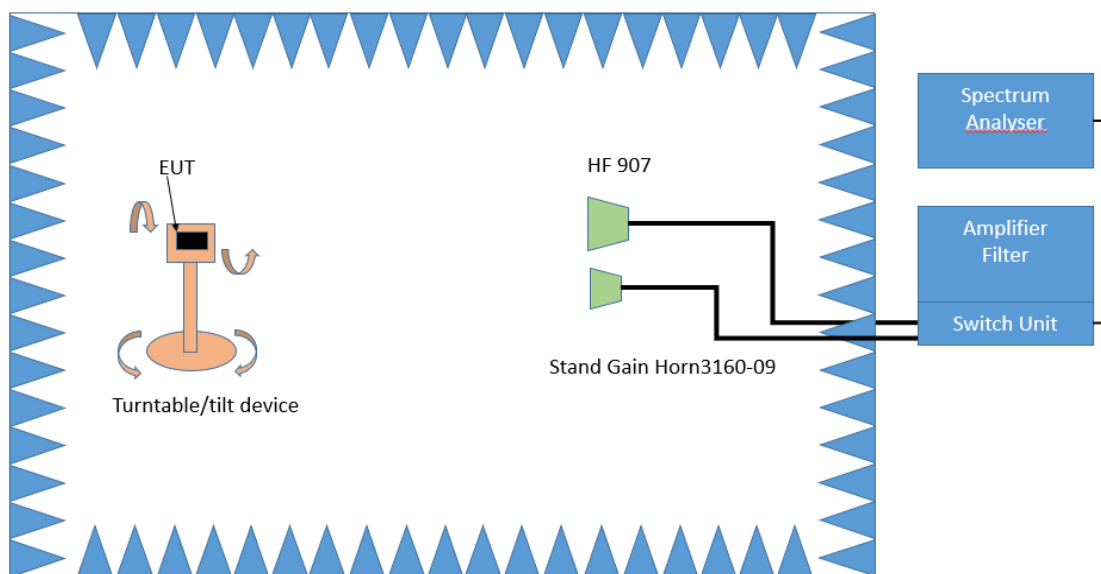

Test Setup; Spurious Emission Radiated (FAC), 1 GHz-26.5 GHz

Step 1:

The EUT is turned during the preliminary measurement across the elevation axis, with a step size of 90 °.

The turn table step size (azimuth angle) for the preliminary measurement is 45 °.

Spectrum analyser settings:

- Detector: Peak, Average
- RBW = 1 MHz
- VBW = 3 MHz

Step 2:

The turn table azimuth will slowly vary by $\pm 22.5^\circ$.

The elevation angle will slowly vary by $\pm 45^\circ$

Spectrum analyser settings:

- Detector: Peak

Step 3:

Spectrum analyser settings for step 3:

- Detector: Peak / CISPR Average
- Measured frequencies: in step 1 determined frequencies
- RBW = 1 MHz
- VBW = 3 MHz
- Measuring time: 1 s

5.3.2 TEST REQUIREMENTS / LIMITS

A) FCC

FCC Part 15 Subpart E, §15.407 (b)(1)

For transmitters operating in the 5150–5250 MHz band:

Limit: –27 dBm/MHz EIRP outside of the band 5150–5350 MHz.

FCC Part 15 Subpart E, §15.407 (b)(2)

For transmitters operating in the 5250–5350 MHz band:

Limit: –27 dBm/MHz EIRP outside of the band 5150–5350 MHz.

FCC Part 15 Subpart E, §15.407 (b)(3)

For transmitters operating in the 5470–5725 MHz band:

Limit: –27 dBm/MHz EIRP outside of the band 5470–5725 MHz.

FCC Part 15 Subpart E, §15.407 (b)(4)

For transmitters operating in the 5725–5850 MHz band:

Limit: –27 dBm/MHz at 75 MHz or more above or below the band edge
increasing linearly to 10 dBm/MHz at 25 MHz above or below the band edge
increasing linearly to 15.6 dBm/MHz at 5 MHz above or below the band edge
increasing linearly to 27 dBm/MHz at the band edge.

FCC Part 15 Subpart E, §15.407 (b) (5)

For transmitters operating within the 5.925-7.125 GHz band:

Limit: –27 dBm/MHz EIRP outside of the band 5.925-7.125 GHz.

FCC Part 15 Subpart E, §15.407 (b) (6)

For transmitters operating within the 5.925-7.125 GHz bands:

Power spectral density must be suppressed by 20 dB at 1 MHz outside of channel edge, by 28 dB at one channel bandwidth from the channel center, and by 40 dB at one- and one-half times the channel bandwidth away from channel center. At frequencies between one megahertz outside an unlicensed device's channel edge and one channel bandwidth from the center of the channel, the limits must be linearly interpolated between 20 dB and 28 dB suppression, and at frequencies between one and one- and one-half times an unlicensed device's channel bandwidth, the limits must be linearly interpolated between 28 dB and 40 dB suppression. Emissions removed from the channel center by more than one- and one-half times the channel bandwidth must be suppressed by at least 40 dB.

B) IC

Different frequency bands and limits apply, as compared to the FCC requirements.

RSS-247, 6.2.1.2, Emissions outside the band 5150-5250 MHz, indoor operation only:

Limit: –27 dBm/MHz EIRP outside of the band 5150–5250 MHz.

RSS-247, 6.2.2.2, Emissions outside the band 5250-5350 MHz:

Limit: -27 dBm/MHz EIRP outside of the band 5250–5350 MHz.

RSS-247, 6.2.3.2, Emissions outside the bands 5470–5600 MHz and 5650–5725 MHz:

Limit: -27 dBm/MHz EIRP outside of the band 5470–5725 MHz.

However, devices with bandwidth overlapping the band edge of 5725 MHz can meet the emission limit of -27 dBm/MHz e.i.r.p. at 5850 MHz instead of 5725 MHz.

Note: No operation is permitted for the frequency range 5600–5650 MHz.

RSS-247, 6.2.4.2, Emissions outside the band 5725–5850 MHz:

- a. 27 dBm/MHz at frequencies from the band edges decreasing linearly to 15.6 dBm/MHz at 5 MHz above or below the band edges;
- b. 15.6 dBm/MHz at 5 MHz above or below the band edges decreasing linearly to 10 dBm/MHz at 25 MHz above or below the band edges;
- c. 10 dBm/MHz at 25 MHz above or below the band edges decreasing linearly to -27 dBm/MHz at 75 MHz above or below the band edges; and
- d. -27 dBm/MHz at frequencies more than 75 MHz above or below the band edges.

C) FCC & IC

For band edges connected to a restricted band, the limits are specified in Section 15.209(a)

FCC Part 15, Subpart C, §15.209, Radiated Emission Limits

Frequency in MHz	Limit ($\mu\text{V}/\text{m}$)	Measurement distance (m)	Limits (dB $\mu\text{V}/\text{m}$)
0.009 – 0.49	2400/F(kHz)@300m	3	(48.5 – 13.8)@300m
0.49 – 1.705	24000/F(kHz)@30m	3	(33.8 – 23.0)@30m
1.705 – 30	30@30m	3	29.5@30m

The measured values are corrected with an inverse linear distance extrapolation factor (40 dB/decade) according FCC 15.31 (2).

Frequency in MHz	Limit ($\mu\text{V}/\text{m}$)	Measurement distance (m)	Limits (dB $\mu\text{V}/\text{m}$)
30 – 88	100@3m	3	40.0@3m
88 – 216	150@3m	3	43.5@3m
216 – 960	200@3m	3	46.0@3m
960 – 26000	500@3m	3	54.0@3m
26000 – 40000	500@3m	1	54.0@3m

The measured values above 26 GHz are corrected with an inverse linear distance extrapolation factor (20 dB/decade).

§15.35(b) ..., there is also a limit on the radio frequency emissions, as measured using instrumentation with a peak detector function, corresponding to 20 dB above the maximum permitted average limit....

Used conversion factor: $\text{Limit (dB}\mu\text{V}/\text{m)} = 20 \log (\text{Limit } (\mu\text{V}/\text{m})/1\mu\text{V}/\text{m})$

5.3.3 TEST PROTOCOL

Ambient temperature: 27 - 31 °C
 Air Pressure: 1006 - 1011 hPa
 Humidity: 38 - 47 %
 WLAN a-Mode; 20 MHz; 6 Mbit/s
 Applied duty cycle correction (AV): 0 dB

U-NII-Subband	Antenna	Ch. Center Freq. [MHz]	Band Edge Freq. [MHz]	Spurious Level [dBµV/m]	Detector	RBW [kHz]	Limit [dBµV/m]	Margin [dB]	Limit Type
1	Taoglas	5180	5150.0	68.3	PEAK	1000	74.0	5.7	BE-RB
1	Taoglas	5180	5150.0	50.8	AV	1000	54.0	3.2	BE-RB
1	Molex	5180	5150.0	63.7	PEAK	1000	74.0	10.3	BE-RB
1	Molex	5180	5150.0	46.6	AV	1000	54.0	7.4	BE-RB
2A	Molex	5320	5350.0	68.5	PEAK	1000	74.0	5.5	BE-RB
2A	Molex	5320	5350.0	49.2	AV	1000	54.0	4.8	BE-RB
2A	Taoglas	5320	5350.0	63.8	PEAK	1000	74.0	10.2	BE-RB
2A	Taoglas	5320	5350.0	47.2	AV	1000	54.0	6.8	BE-RB
2C	Molex	5500	5460.0	62.6	PEAK	1000	74.0	11.4	BE-RB
2C	Molex	5500	5460.0	47.2	AV	1000	54.0	6.8	BE-RB
2C	Molex	5500	5470.0	63.2	PEAK	1000	68.2	5.0	BE-UE
2C	Taoglas	5500	5460.0	63.4	PEAK	1000	74.0	10.6	BE-RB
2C	Taoglas	5500	5460.0	48.4	AV	1000	54.0	5.6	BE-RB
2C	Taoglas	5500	5470.0	63.2	PEAK	1000	68.2	5.0	BE-UE
2C	Molex	5700	5725.0	64.5	PEAK	1000	68.2	3.7	BE-UE
2C	Taoglas	5700	5725.0	64.1	PEAK	1000	68.2	4.1	BE-UE
3	Molex	5745	5725.0	70.5	PEAK	1000	122.2	51.7	BE-UE
3	Taoglas	5745	5725.0	74.4	PEAK	1000	122.2	47.8	BE-UE
3	Taoglas	5825	5850.0	69.5	PEAK	1000	122.2	52.7	BE-UE
3	Molex	5825	5850.0	72.0	PEAK	1000	122.2	50.2	BE-UE

WLAN n-Mode; 20 MHz; MCS 0; SISO
 Applied duty cycle correction (AV): 0 dB

U-NII-Subband	Antenna	Ch. Center Freq. [MHz]	Band Edge Freq. [MHz]	Spurious Level [dB μ V/m]	Detector	RBW [kHz]	Limit [dB μ V/m]	Margin [dB]	Limit Type
1	Molex	5180	5150.0	66.3	PEAK	1000	74.0	7.7	BE-RB
1	Molex	5180	5150.0	48.1	AV	1000	54.0	5.9	BE-RB
1	Taoglas	5180	5150.0	68.1	PEAK	1000	74.0	5.9	BE-RB
1	Taoglas	5180	5150.0	49.4	AV	1000	54.0	4.6	BE-RB
2C	Molex	5500	5460.0	62.2	PEAK	1000	74.0	11.8	BE-RB
2C	Molex	5500	5460.0	47.0	AV	1000	54.0	7.0	BE-RB
2C	Molex	5500	5470.0	63.3	PEAK	1000	68.2	4.9	BE-UE
2C	Taoglas	5500	5460.0	62.3	PEAK	1000	74.0	11.7	BE-RB
2C	Taoglas	5500	5460.0	47.1	AV	1000	54.0	6.9	BE-RB
2C	Taoglas	5500	5470.0	62.4	PEAK	1000	68.2	5.8	BE-UE

WLAN n-Mode; 40 MHz; MCS 0; SISO
 Applied duty cycle correction (AV): 0 dB

U-NII-Subband	Antenna	Ch. Center Freq. [MHz]	Band Edge Freq. [MHz]	Spurious Level [dB μ V/m]	Detector	RBW [kHz]	Limit [dB μ V/m]	Margin [dB]	Limit Type
1	Molex	5190	5150.0	67.9	PEAK	1000	74.0	6.1	BE-RB
1	Molex	5190	5150.0	49.0	AV	1000	54.0	5.0	BE-RB
1	Taoglas	5190	5150.0	67.6	PEAK	1000	74.0	6.4	BE-RB
1	Taoglas	5190	5150.0	50.9	AV	1000	54.0	3.1	BE-RB
2C	Taoglas	5510	5460.0	60.6	PEAK	1000	74.0	13.4	BE-RB
2C	Taoglas	5510	5460.0	46.9	AV	1000	54.0	7.1	BE-RB
2C	Taoglas	5510	5470.0	64.7	PEAK	1000	68.2	3.5	BE-UE
2C	Molex	5510	5460.0	60.5	PEAK	1000	74.0	13.5	BE-RB
2C	Molex	5510	5460.0	46.8	AV	1000	54.0	7.2	BE-RB
2C	Molex	5510	5470.0	63.5	PEAK	1000	68.2	4.7	BE-UE

Remark: Please see next sub-clause for the measurement plot.

5.3.4 MEASUREMENT PLOT (EXAMPLE PLOT, SHOWING WORST CASE, IF APPLICABLE)

Radio Technology = WLAN a, Operating Frequency = low, Subband = U-NII-1 (S03_161_AG01)

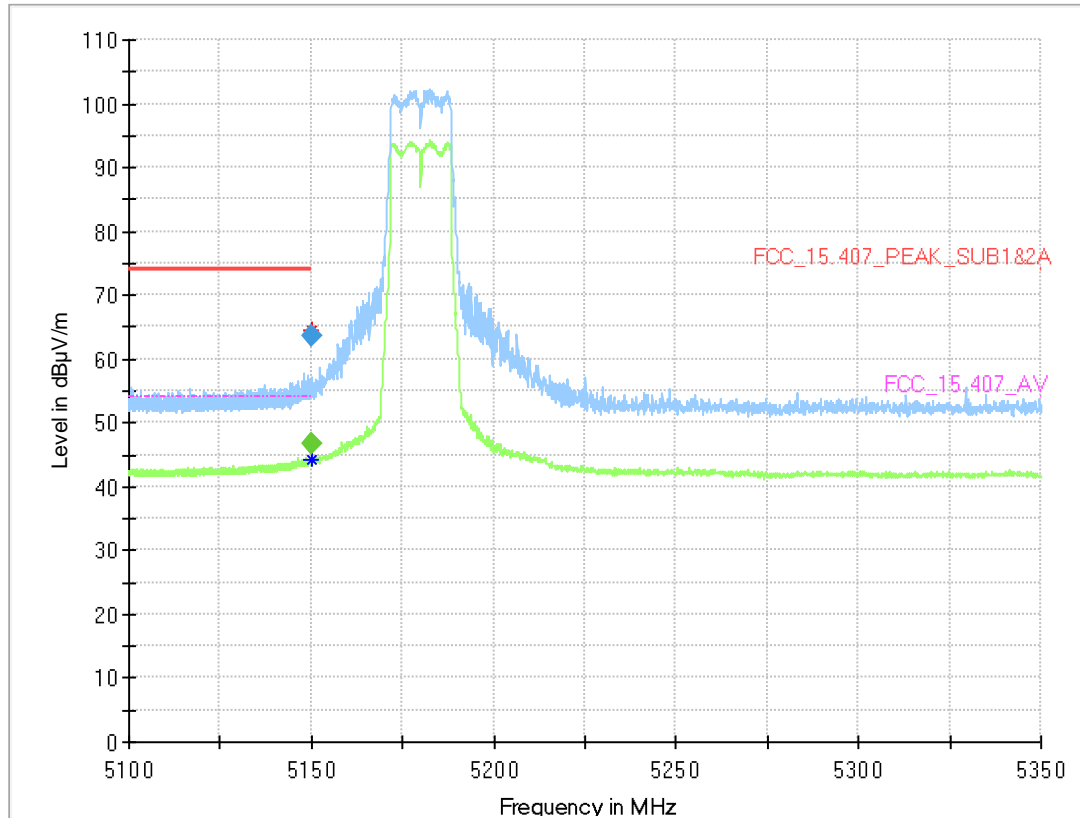

Final Result

Frequency (MHz)	MaxPeak (dBµV/m)	CAverage (dBµV/m)	Limit (dBµV/m)	Margin (dB)	Meas. Time (ms)	Bandwidth (kHz)	Height (cm)	Pol	Azimuth (deg)	Elevation (deg)	Corr. (dB/m)
5149.925	---	46.6	54.00	7.38	1000.0	1000.000	150.0	H	-169.0	105.0	15.0
5149.925	63.7	---	74.00	10.25	1000.0	1000.000	150.0	H	-169.0	105.0	15.0

Radio Technology = WLAN a, Operating Frequency = high, Subband = U-NII-2A
(S03_161_AG01)

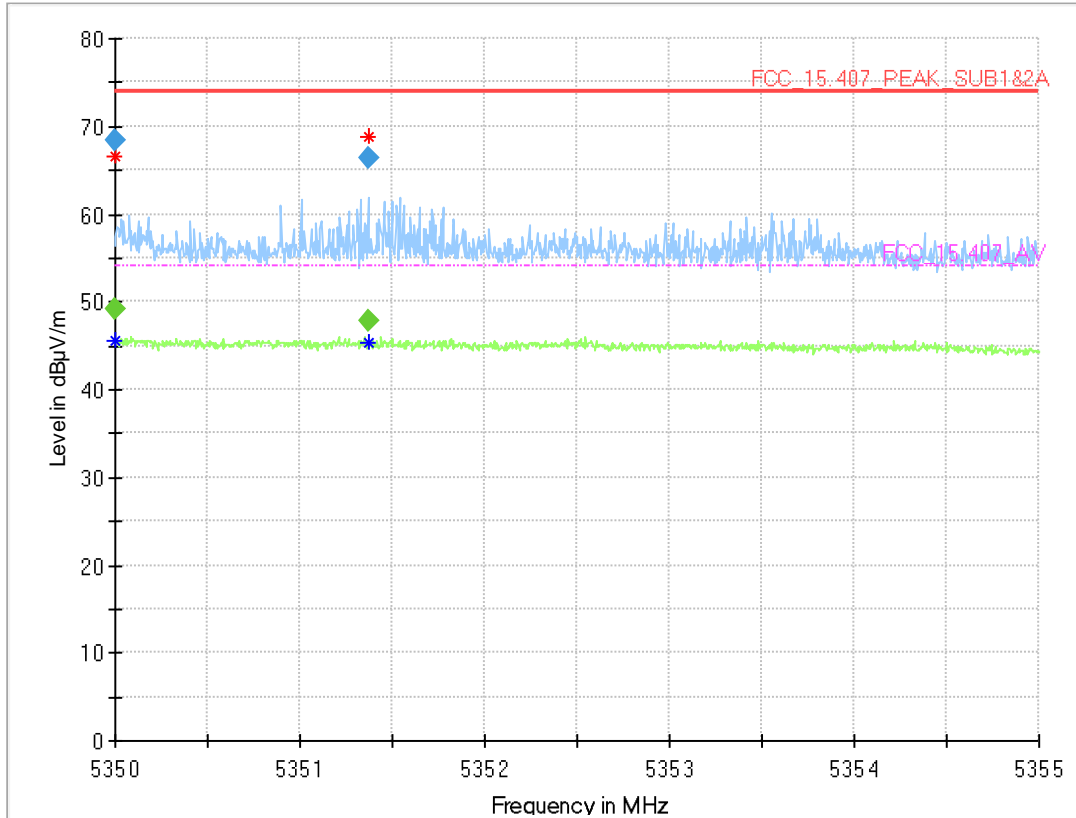

Final_Result

Frequency (MHz)	MaxPeak (dBµV/m)	CAverage (dBµV/m)	Limit (dBµV/m)	Margin (dB)	Meas. Time (ms)	Bandwidth (kHz)	Height (cm)	Pol	Azimuth (deg)	Elevation (deg)	Corr. (dB/m)
5350.000	---	49.2	54.00	4.80	1000.0	1000.000	150.0	H	-188.0	87.0	15.3
5350.000	68.5	---	74.00	5.54	1000.0	1000.000	150.0	H	-188.0	87.0	15.3
5351.370	---	47.8	54.00	6.20	1000.0	1000.000	150.0	H	-181.0	105.0	15.3
5351.370	66.3	---	74.00	7.73	1000.0	1000.000	150.0	H	-181.0	105.0	15.3

Radio Technology = WLAN a, Operating Frequency = low, Subband = U-NII-2C (S03_161_AG01)

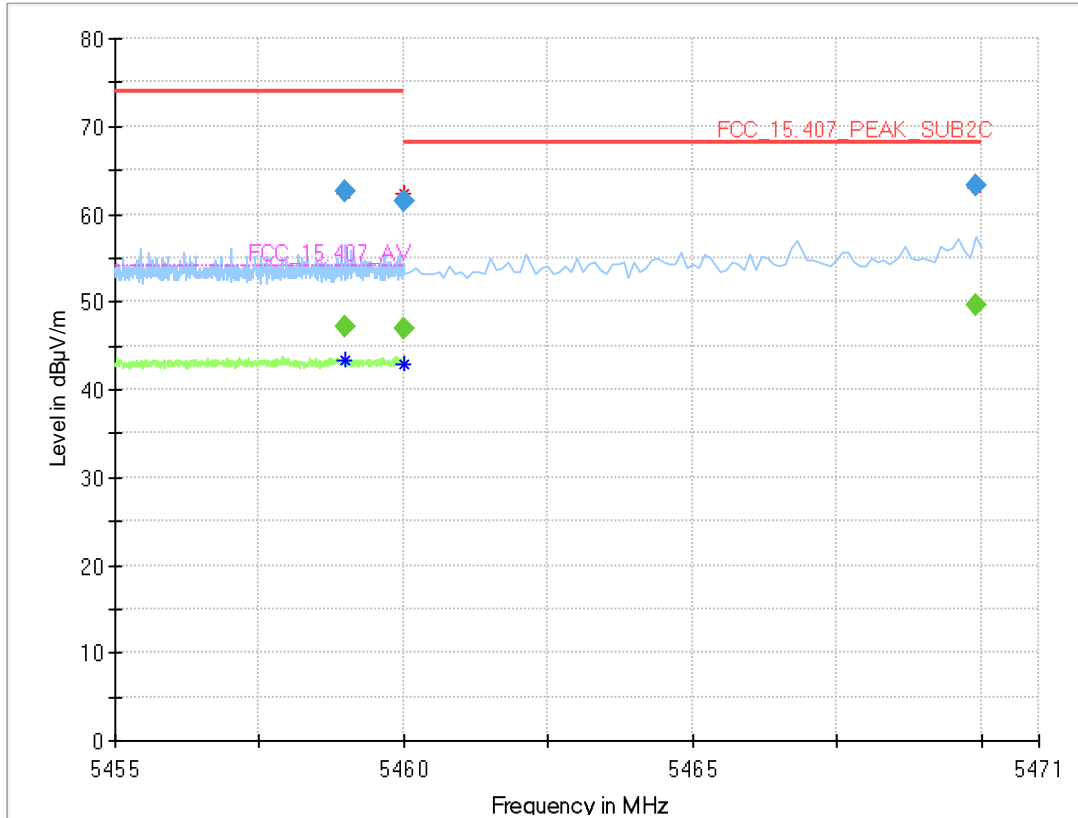

Final Result

Frequency (MHz)	MaxPeak (dBµV/m)	CAverage (dBµV/m)	Limit (dBµV/m)	Margin (dB)	Meas. Time (ms)	Bandwidth (kHz)	Height (cm)	Pol	Azimuth (deg)	Elevation (deg)	Corr. (dB/m)
5459.000	---	47.2	54.00	6.76	1000.0	1000.000	150.0	H	-172.0	84.0	15.9
5459.000	62.6	---	74.00	11.42	1000.0	1000.000	150.0	H	-172.0	84.0	15.9
5459.990	---	46.8	54.00	7.17	1000.0	1000.000	150.0	H	-124.0	91.0	15.9
5459.990	61.4	---	74.00	12.65	1000.0	1000.000	150.0	H	-124.0	91.0	15.9
5469.900	---	49.5	---	---	1000.0	1000.000	150.0	H	-169.0	90.0	15.7
5469.900	63.2	---	68.20	4.96	1000.0	1000.000	150.0	H	-169.0	90.0	15.7

Radio Technology = WLAN a, Operating Frequency = high, Subband = U-NII-2C
(S03_161_AG01)

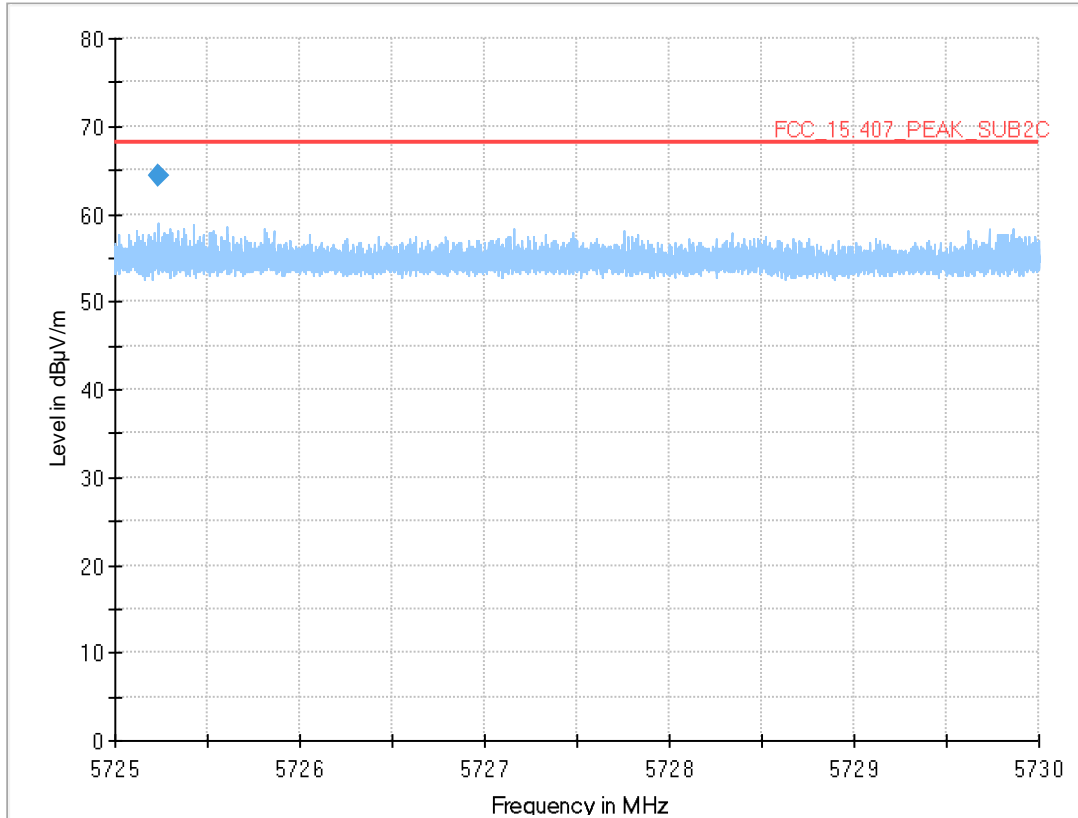

Final Result

Frequency (MHz)	MaxPeak (dBµV/m)	CAverage (dBµV/m)	Limit (dBµV/m)	Margin (dB)	Meas. Time (ms)	Bandwidth (kHz)	Height (cm)	Pol	Azimuth (deg)	Elevation (deg)	Corr. (dB/m)
5725.229	64.5	---	68.20	3.75	1000.0	1000.000	150.0	H	-169.0	90.0	15.6

Radio Technology = WLAN a, Operating Frequency = low, Subband = U-NII-3
(S03_161_AG01)

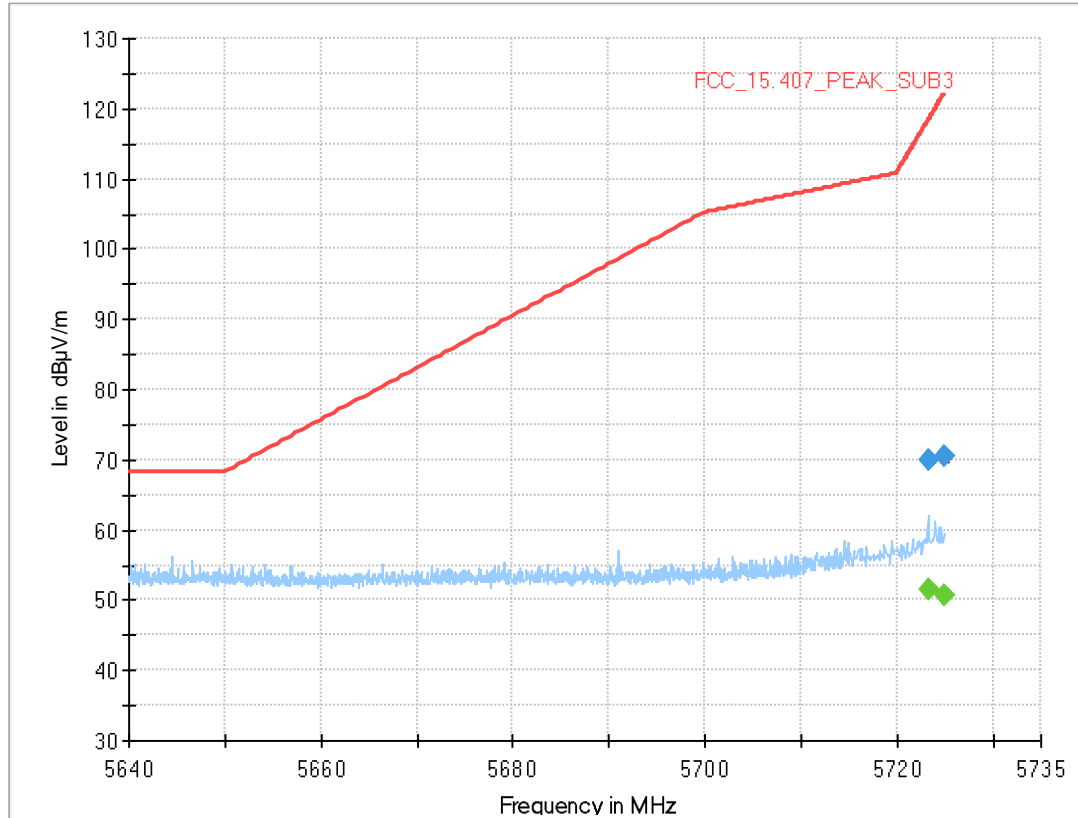

Final Result

Frequency (MHz)	MaxPeak (dBµV/m)	CAverage (dBµV/m)	Limit (dBµV/m)	Margin (dB)	Meas. Time (ms)	Bandwidth (kHz)	Height (cm)	Pol	Azimuth (deg)	Elevation (deg)	Corr. (dB/m)
5723.300	---	51.4	---	---	1000.0	1000.000	150.0	H	-171.0	87.0	15.6
5723.300	69.8	---	118.3	48.51	1000.0	1000.000	150.0	H	-171.0	87.0	15.6
5725.000	---	50.7	---	---	1000.0	1000.000	150.0	H	11.0	82.0	15.6
5725.000	70.5	---	122.2	51.75	1000.0	1000.000	150.0	H	11.0	82.0	15.6

Radio Technology = WLAN a, Operating Frequency = high, Subband = U-NII-3 (S03_161_AG01)

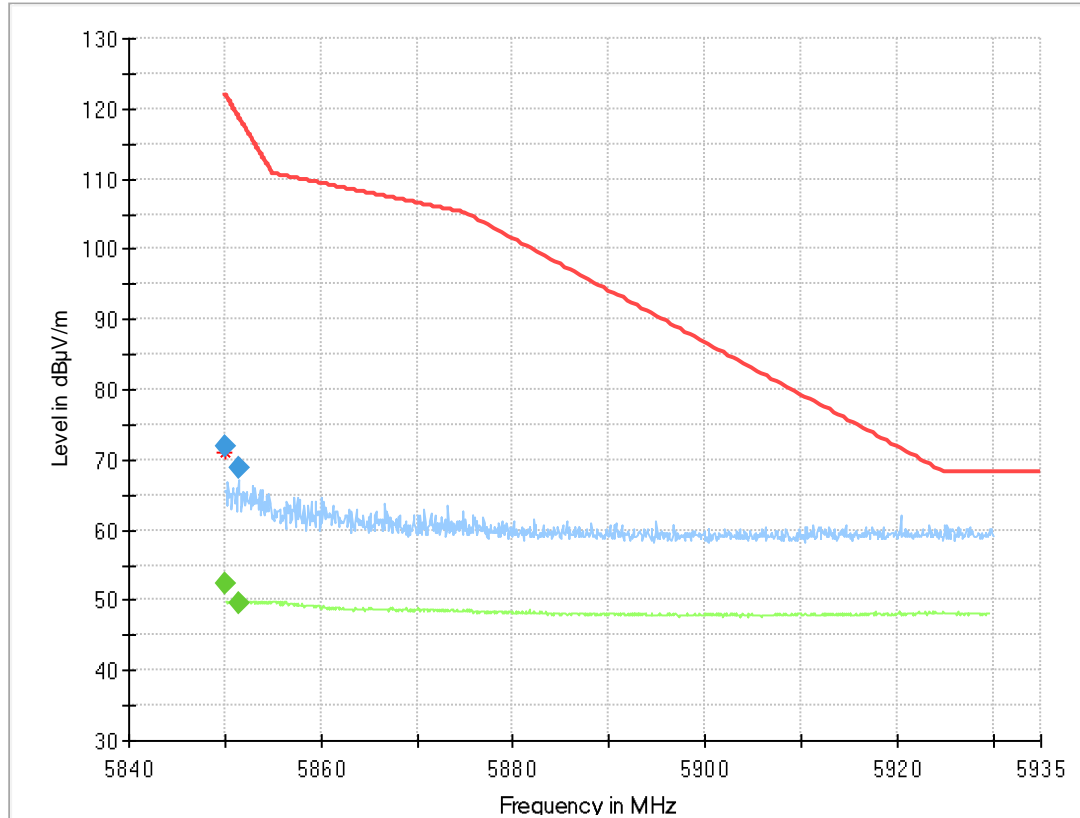

Final Result

Frequency (MHz)	MaxPeak (dBµV/m)	CAverage (dBµV/m)	Limit (dBµV/m)	Margi n (dB)	Meas. Time (ms)	Bandwidt h (kHz)	Heigh t (cm)	Pol	Azimet h (deg)	Elevatio n (deg)	Corr. (dB/ m)
5850.000	---	52.5	---	---	1000.0	1000.000	150.0	H	-9.0	15.0	15.8
5850.000	72.0	---	122.2	50.24	1000.0	1000.000	150.0	H	-9.0	15.0	15.8
5851.440	---	49.7	---	---	1000.0	1000.000	150.0	H	146.0	103.0	15.8
5851.440	68.8	---	118.9	50.10	1000.0	1000.000	150.0	H	146.0	103.0	15.8
11649.712	---	47.5	54.00	6.53	1000.0	1000.000	150.0	V	-185.0	-12.0	-6.5
11649.712	60.8	---	74.00	13.23	1000.0	1000.000	150.0	V	-185.0	-12.0	-6.5
23177.540	---	38.6	---	---	1000.0	1000.000	150.0	V	37.0	102.0	19.8
23177.540	52.3	---	68.20	15.88	1000.0	1000.000	150.0	V	37.0	102.0	19.8

Radio Technology = WLAN a, Operating Frequency = low, Subband = U-NII-1
(S02_161_AG01)

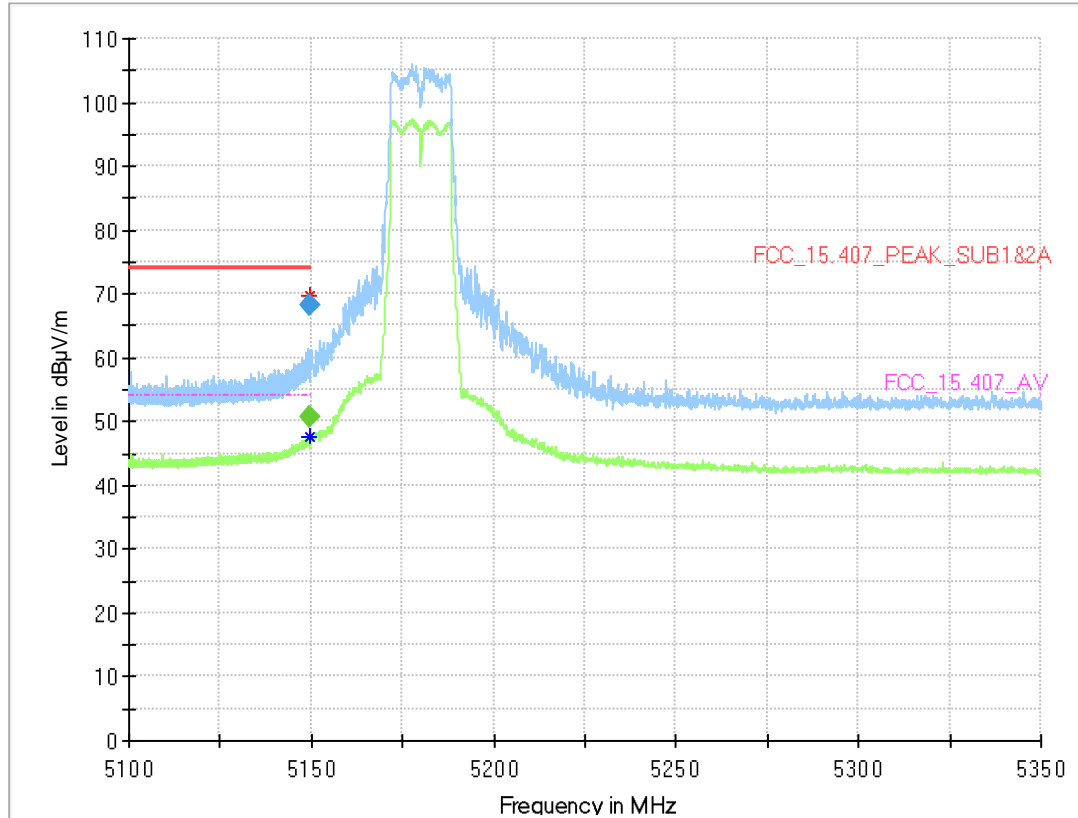

Final Result

Frequency (MHz)	MaxPeak (dBµV/m)	CAverage (dBµV/m)	Limit (dBµV/m)	Margin (dB)	Meas. Time (ms)	Bandwidth (kHz)	Height (cm)	Pol	Azimuth (deg)	Elevation (deg)	Corr. (dB/m)
5149.813	---	50.8	54.00	3.22	1000.0	1000.000	150.0	V	101.0	-7.0	15.0
5149.813	68.3	---	74.00	5.70	1000.0	1000.000	150.0	V	101.0	-7.0	15.0

Radio Technology = WLAN a, Operating Frequency = high, Subband = U-NII-2A
(S02_161_AG01)

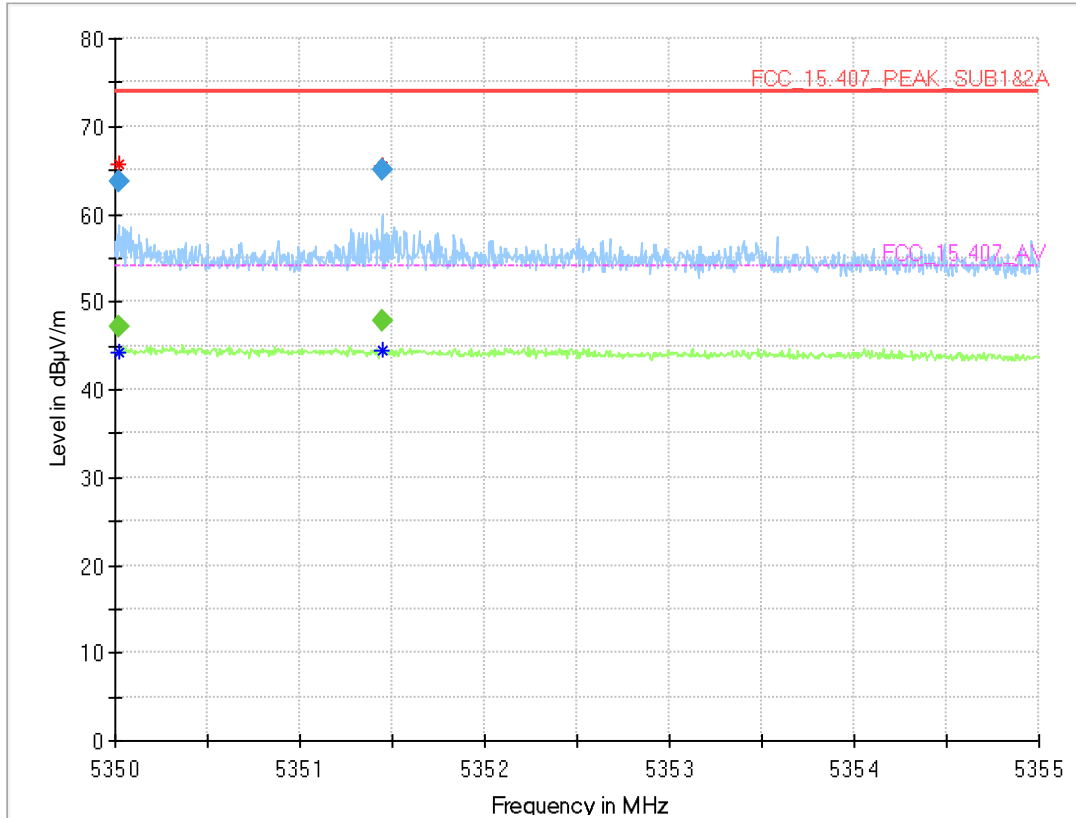

Final_Result

Frequency (MHz)	MaxPeak (dBµV/m)	CAverage (dBµV/m)	Limit (dBµV/m)	Margin (dB)	Meas. Time (ms)	Bandwidth (kHz)	Height (cm)	Pol	Azimuth (deg)	Elevation (deg)	Corr. (dB/m)
5350.020	---	47.2	54.00	6.78	1000.0	1000.000	150.0	V	84.0	15.0	15.3
5350.020	63.8	---	74.00	10.25	1000.0	1000.000	150.0	V	84.0	15.0	15.3
5351.445	---	47.9	54.00	6.11	1000.0	1000.000	150.0	H	-46.0	105.0	15.3
5351.445	65.1	---	74.00	8.89	1000.0	1000.000	150.0	H	-46.0	105.0	15.3

Radio Technology = WLAN a, Operating Frequency = low, Subband = U-NII-2C (S02_161_AG01)

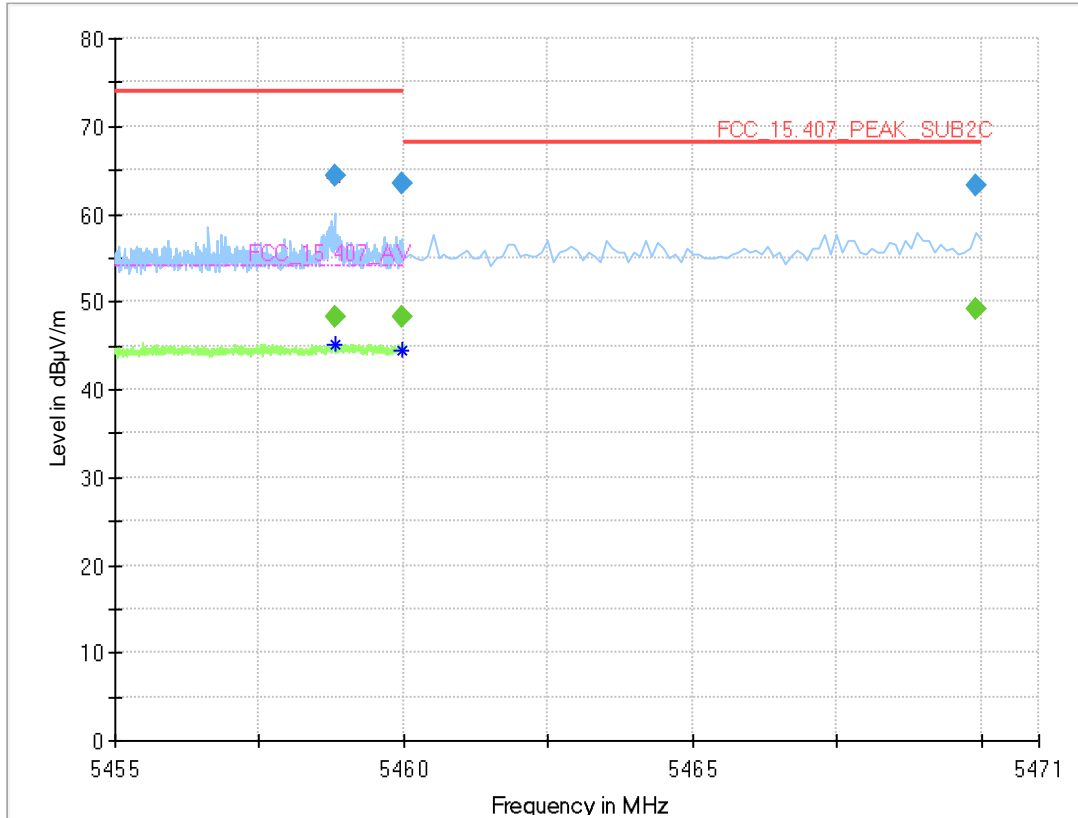

Final Result

Frequency (MHz)	MaxPeak (dBµV/m)	CAverage (dBµV/m)	Limit (dBµV/m)	Margin (dB)	Meas. Time (ms)	Bandwidth (kHz)	Height (cm)	Pol	Azimuth (deg)	Elevation (deg)	Corr. (dB/m)
5458.800	---	48.4	54.00	5.65	1000.0	1000.000	150.0	H	-47.0	90.0	15.9
5458.800	64.4	---	74.00	9.58	1000.0	1000.000	150.0	H	-47.0	90.0	15.9
5459.955	---	48.4	54.00	5.63	1000.0	1000.000	150.0	H	-48.0	105.0	15.9
5459.955	63.4	---	74.00	10.63	1000.0	1000.000	150.0	H	-48.0	105.0	15.9
5469.900	---	49.3	---	---	1000.0	1000.000	150.0	H	-46.0	95.0	15.7
5469.900	63.2	---	68.20	5.01	1000.0	1000.000	150.0	H	-46.0	95.0	15.7

Radio Technology = WLAN a, Operating Frequency = high, Subband = U-NII-2C
(S02_161_AG01)

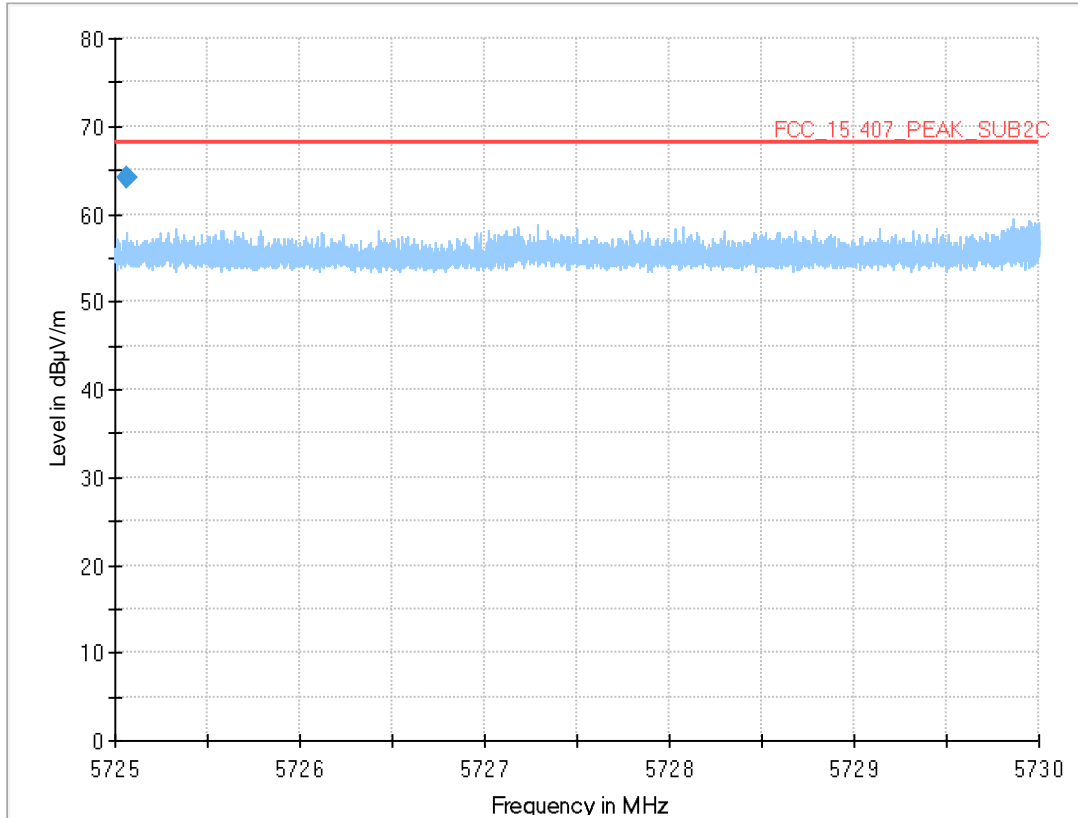

Final Result

Frequency (MHz)	MaxPeak (dBµV/m)	CAverage (dBµV/m)	Limit (dBµV/m)	Margin (dB)	Meas. Time (ms)	Bandwidth (kHz)	Height (cm)	Pol	Azimuth (deg)	Elevation (deg)	Corr. (dB/m)
5725.060	64.1	---	68.20	4.10	1000.0	1000.000	150.0	H	-44.0	82.0	15.6

Radio Technology = WLAN a, Operating Frequency = low, Subband = U-NII-3
(S02_161_AG01)

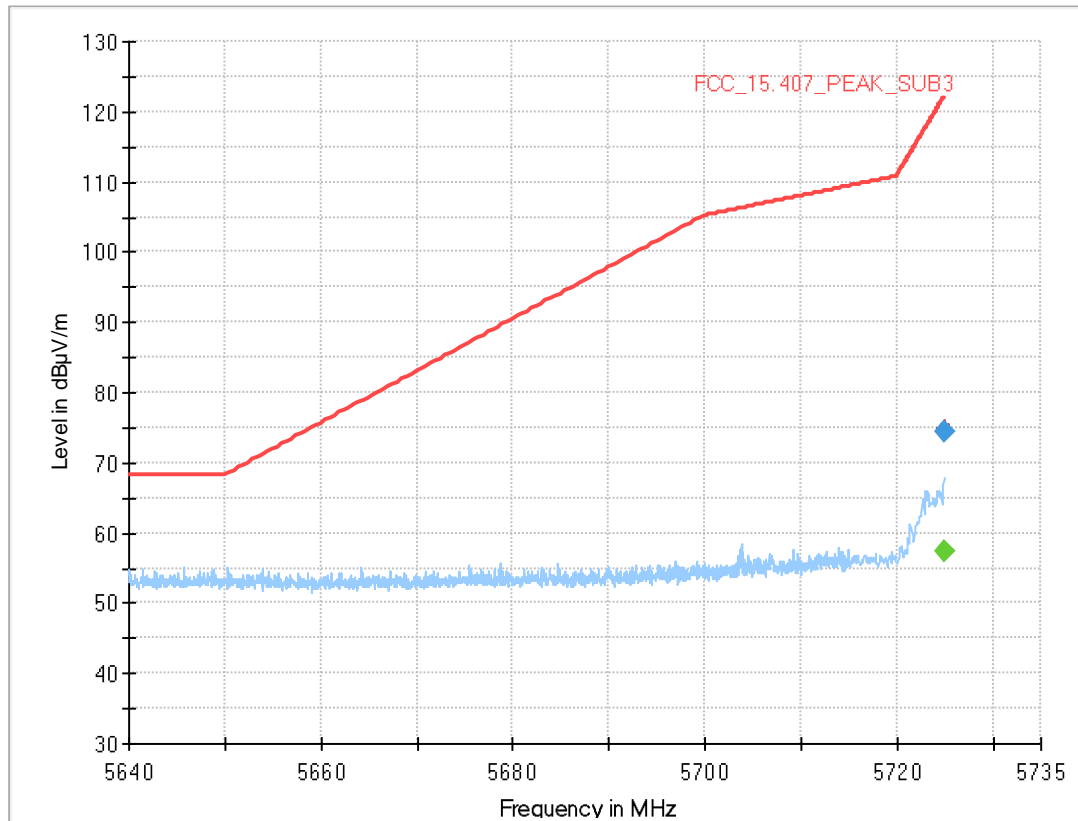

Final Result

Frequency (MHz)	MaxPeak (dBµV/m)	CAverage (dBµV/m)	Limit (dBµV/m)	Margin (dB)	Meas. Time (ms)	Bandwidth (kHz)	Height (cm)	Pol	Azimuth (deg)	Elevation (deg)	Corr. (dB/m)
5725.000	---	57.2	---	---	1000.0	1000.000	150.0	H	48.0	89.0	15.6
5725.000	74.4	---	122.2	47.80	1000.0	1000.000	150.0	H	48.0	89.0	15.6

Radio Technology = WLAN a, Operating Frequency = high, Subband = U-NII-3 (S02_161_AG01)

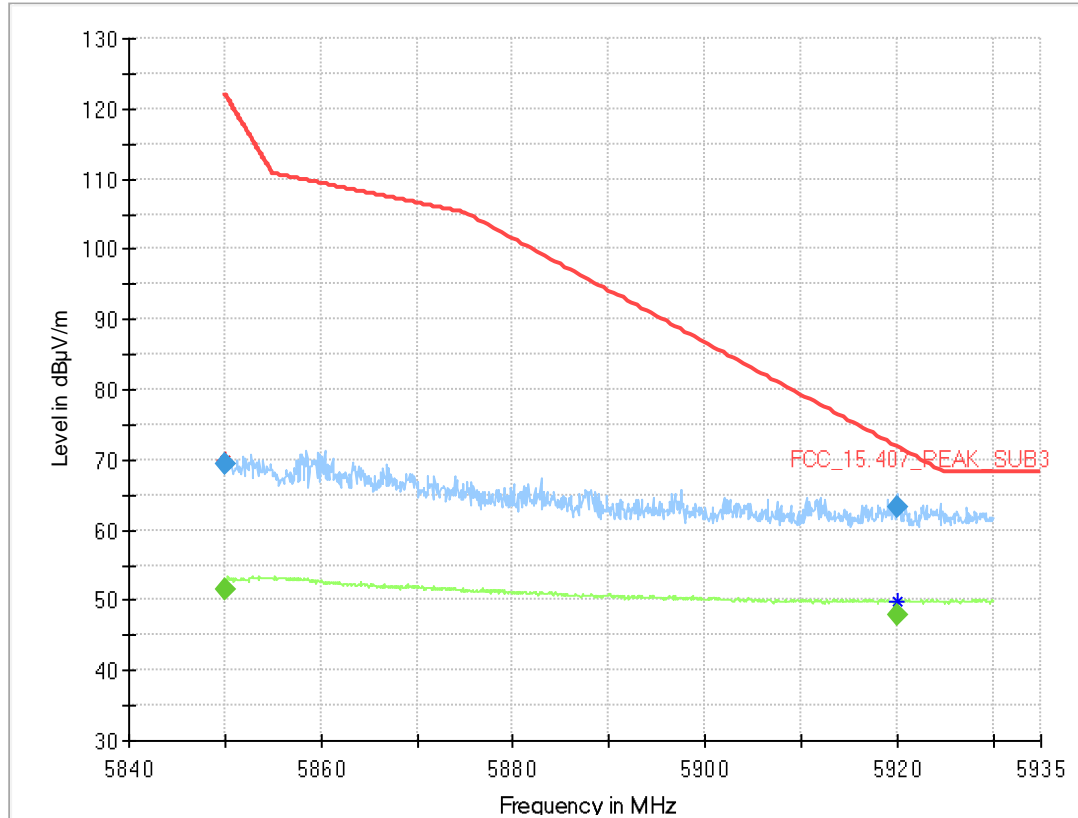

Final Result

Frequency (MHz)	MaxPeak (dBµV/m)	CAverage (dBµV/m)	Limit (dBµV/m)	Margin (dB)	Meas. Time (ms)	Bandwidth (kHz)	Height (cm)	Pol	Azimuth (deg)	Elevation (deg)	Corr. (dB/m)
5850.000	---	51.4	---	---	1000.0	1000.000	150.0	V	-188.0	-6.0	15.8
5850.000	69.5	---	122.2	52.73	1000.0	1000.000	150.0	V	-188.0	-6.0	15.8
5920.000	---	48.0	---	---	1000.0	1000.000	150.0	H	96.0	105.0	16.3
5920.000	63.2	---	71.90	8.74	1000.0	1000.000	150.0	H	96.0	105.0	16.3

Radio Technology = WLAN n 20 MHz, Operating Frequency = low, Subband = U-NII-1 (S03_161_AG01)

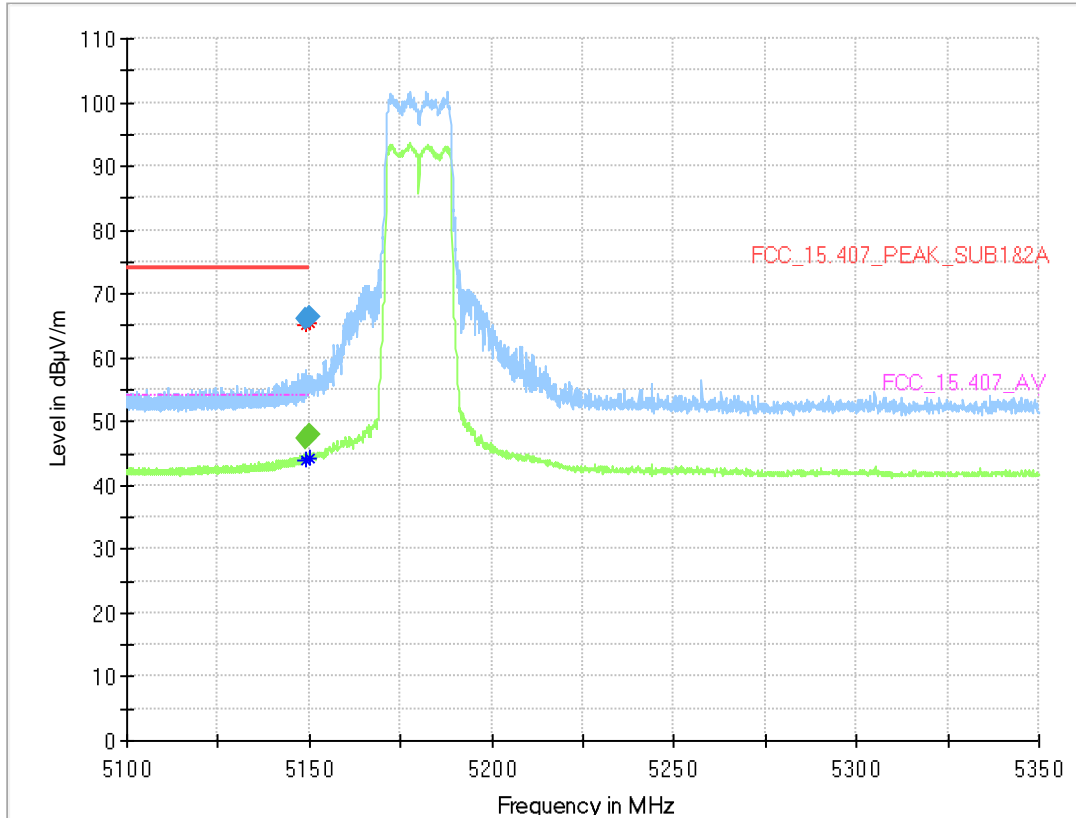

Final Result

Frequency (MHz)	MaxPeak (dBµV/m)	CAverage (dBµV/m)	Limit (dBµV/m)	Margin (dB)	Meas. Time (ms)	Bandwidth (kHz)	Height (cm)	Pol	Azimuth (deg)	Elevation (deg)	Corr. (dB/m)
5149.088	---	47.4	54.00	6.59	1000.0	1000.000	150.0	H	-171.0	90.0	15.0
5149.088	66.2	---	74.00	7.83	1000.0	1000.000	150.0	H	-171.0	90.0	15.0
5150.000	---	48.1	54.00	5.95	1000.0	1000.000	150.0	H	-178.0	105.0	15.0
5150.000	66.3	---	74.00	7.72	1000.0	1000.000	150.0	H	-178.0	105.0	15.0

Radio Technology = WLAN n 20 MHz, Operating Frequency = low, Subband = U-NII-1 (S02_161_AG01)

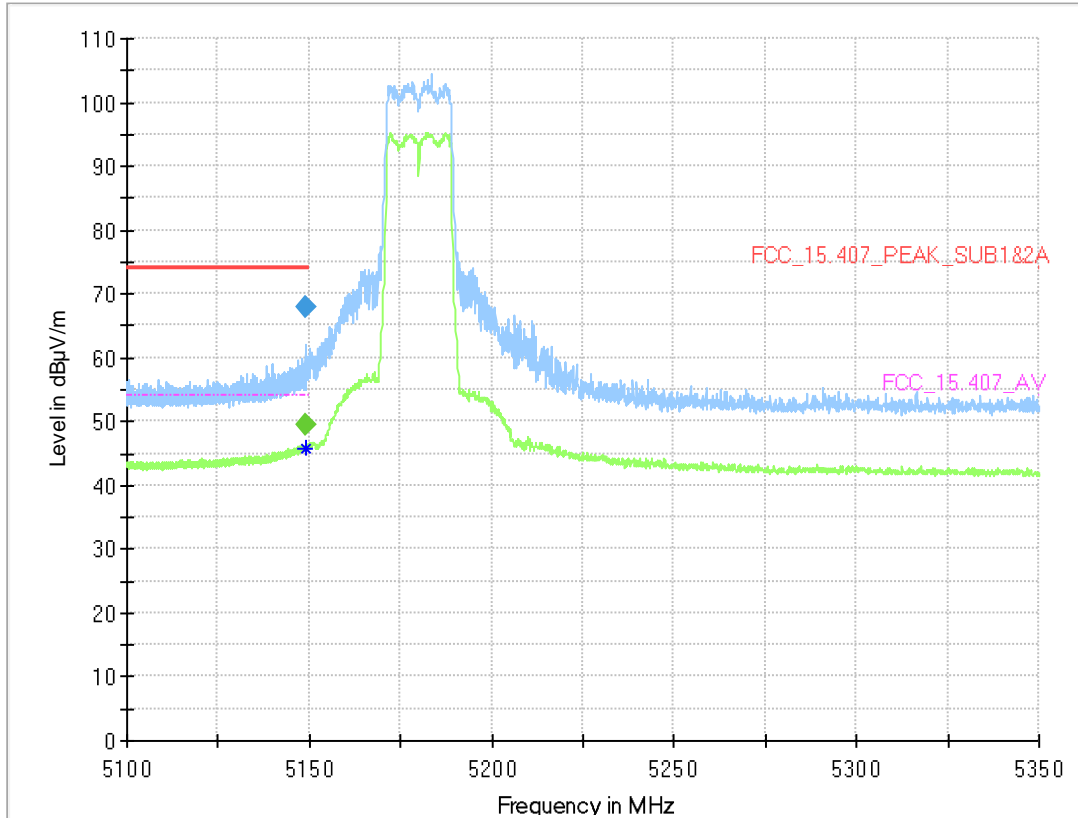

Final Result

Frequency (MHz)	MaxPeak (dBµV/m)	CAverage (dBµV/m)	Limit (dBµV/m)	Margin (dB)	Meas. Time (ms)	Bandwidth (kHz)	Height (cm)	Pol	Azimuth (deg)	Elevation (deg)	Corr. (dB/m)
5149.188	---	49.4	54.00	4.64	1000.0	1000.000	150.0	V	99.0	-4.0	15.0
5149.188	68.1	---	74.00	5.94	1000.0	1000.000	150.0	V	99.0	-4.0	15.0

Radio Technology = WLAN n 20 MHz, Operating Frequency = low, Subband = U-NII-2C (S03_161_AG01)

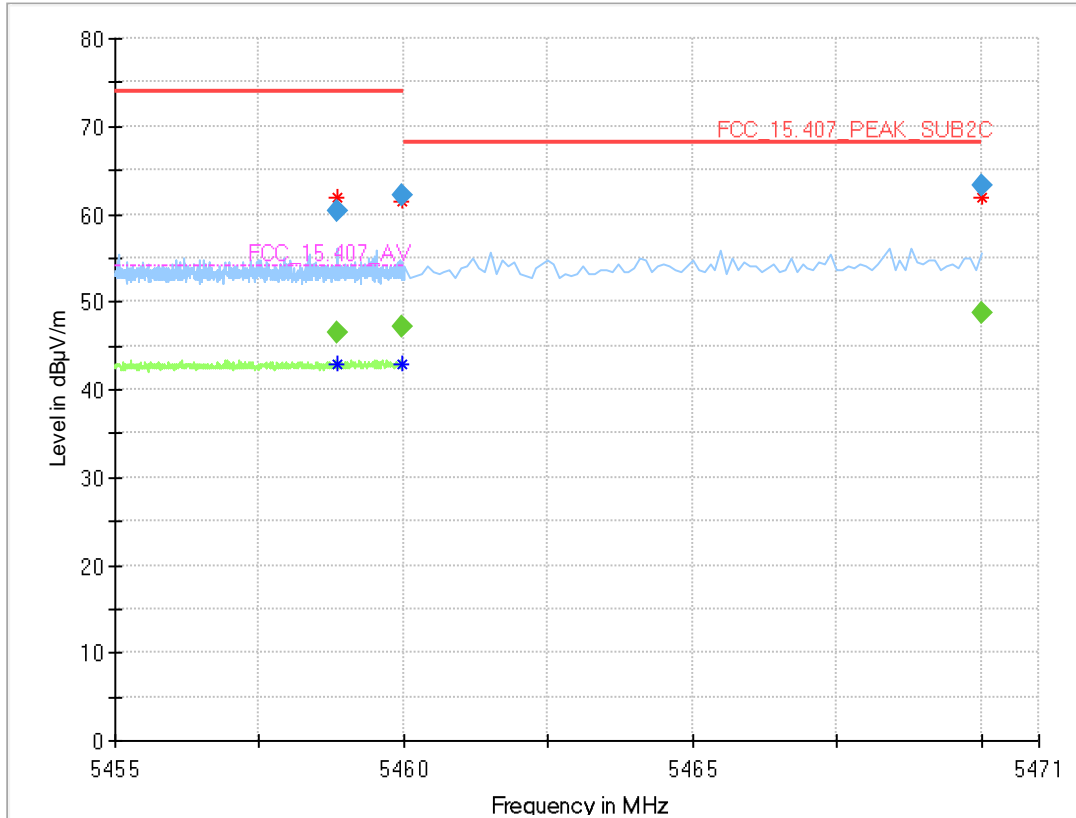

Final_Result

Frequency (MHz)	MaxPeak (dBµV/m)	CAverage (dBµV/m)	Limit (dBµV/m)	Margin (dB)	Meas. Time (ms)	Bandwidth (kHz)	Height (cm)	Pol	Azimuth (deg)	Elevation (deg)	Corr. (dB/m)
5458.845	---	46.4	54.00	7.62	1000.0	1000.000	150.0	H	-172.0	79.0	15.9
5458.845	60.2	---	74.00	13.78	1000.0	1000.000	150.0	H	-172.0	79.0	15.9
5459.975	---	47.0	54.00	6.96	1000.0	1000.000	150.0	H	-172.0	88.0	15.9
5459.975	62.2	---	74.00	11.80	1000.0	1000.000	150.0	H	-172.0	88.0	15.9
5470.000	---	48.7	---	---	1000.0	1000.000	150.0	H	-171.0	89.0	15.7
5470.000	63.3	---	68.20	4.90	1000.0	1000.000	150.0	H	-171.0	89.0	15.7

Radio Technology = WLAN n 20 MHz, Operating Frequency = low, Subband = U-NII-2C (S02_161_AG01)

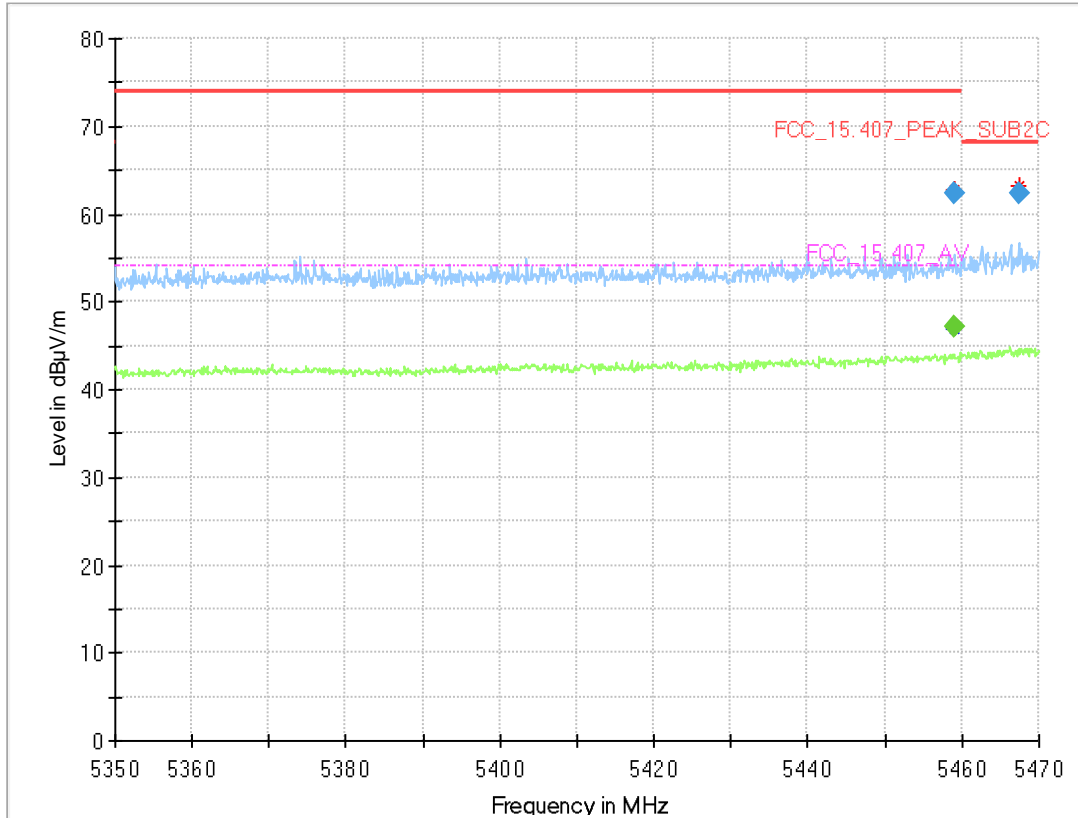

Final Result

Frequency (MHz)	MaxPeak (dBµV/m)	CAverage (dBµV/m)	Limit (dBµV/m)	Margin (dB)	Meas. Time (ms)	Bandwidth (kHz)	Height (cm)	Pol	Azimuth (deg)	Elevation (deg)	Corr. (dB/m)
5459.120	---	47.1	54.00	6.87	1000.0	1000.000	150.0	H	-45.0	83.0	15.9
5459.120	62.3	---	74.00	11.67	1000.0	1000.000	150.0	H	-46.0	98.0	15.9
5467.400	62.4	---	68.20	5.79	1000.0	1000.000	150.0	H	-45.0	105.0	15.7

Radio Technology = WLAN n 40 MHz, Operating Frequency = low, Subband = U-NII-1 (S03_161_AG01)

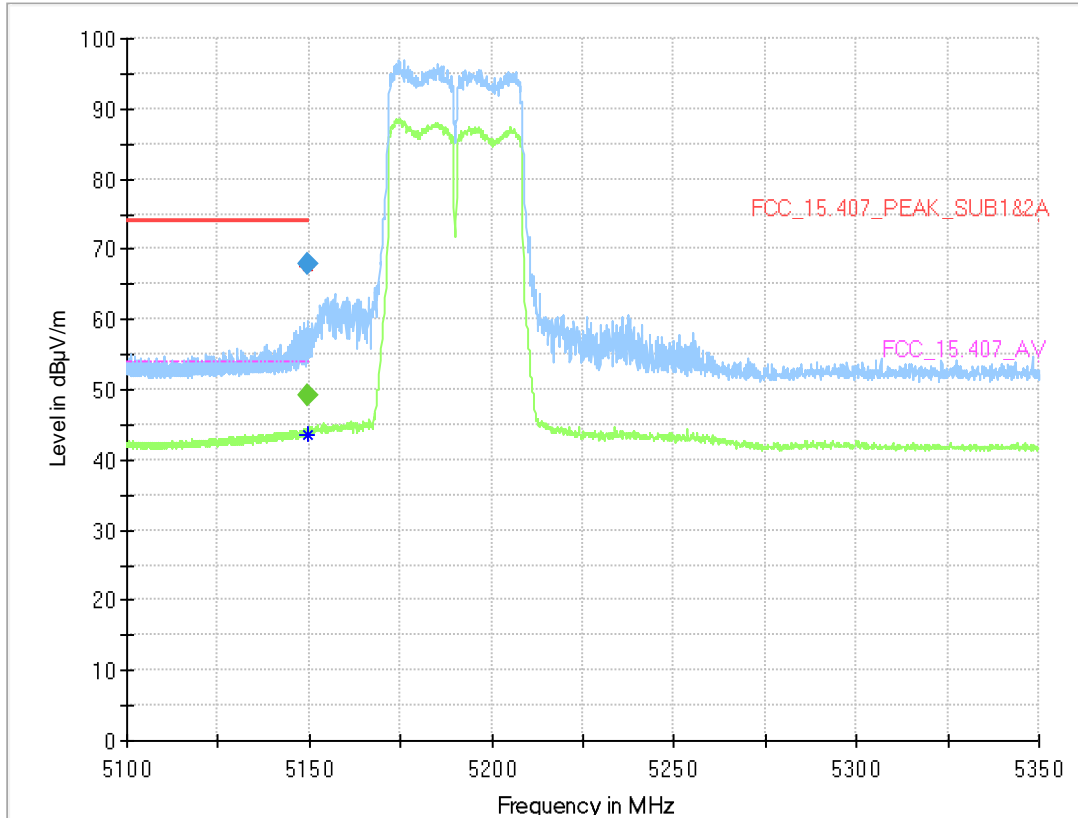

Final Result

Frequency (MHz)	MaxPeak (dBµV/m)	CAverage (dBµV/m)	Limit (dBµV/m)	Margin (dB)	Meas. Time (ms)	Bandwidth (kHz)	Height (cm)	Pol	Azimuth (deg)	Elevation (deg)	Corr. (dB/m)
5149.400	---	49.0	54.00	4.97	1000.0	1000.000	150.0	H	34.0	75.0	15.0
5149.400	67.9	---	74.00	6.14	1000.0	1000.000	150.0	H	34.0	75.0	15.0

Radio Technology = WLAN n 40 MHz, Operating Frequency = low, Subband = U-NII-1 (S02_161_AG01)

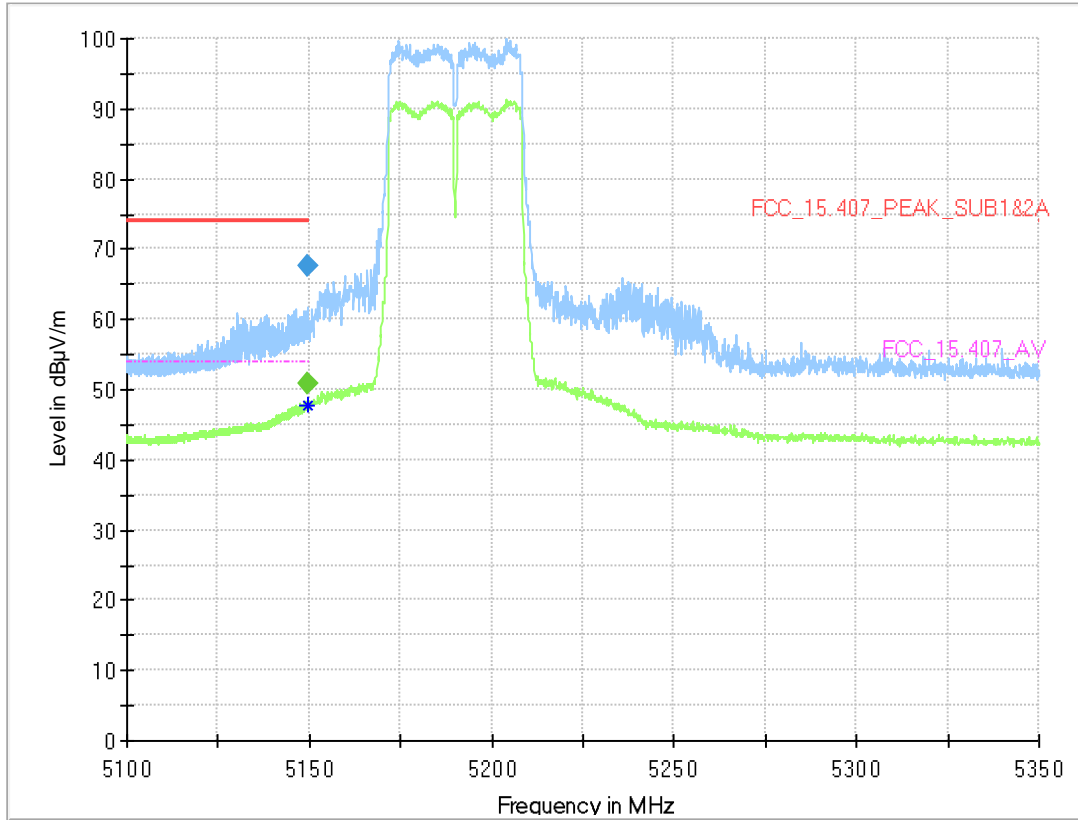

Final Result

Frequency (MHz)	MaxPeak (dBµV/m)	CAverage (dBµV/m)	Limit (dBµV/m)	Margin (dB)	Meas. Time (ms)	Bandwidth (kHz)	Height (cm)	Pol	Azimuth (deg)	Elevation (deg)	Corr. (dB/m)
5149.550	---	50.9	54.00	3.06	1000.0	1000.000	150.0	H	-42.0	92.0	15.0
5149.550	67.6	---	74.00	6.40	1000.0	1000.000	150.0	H	-42.0	92.0	15.0

Radio Technology = WLAN n 40 MHz, Operating Frequency = low, Subband = U-NII-2C (S03_161_AG01)

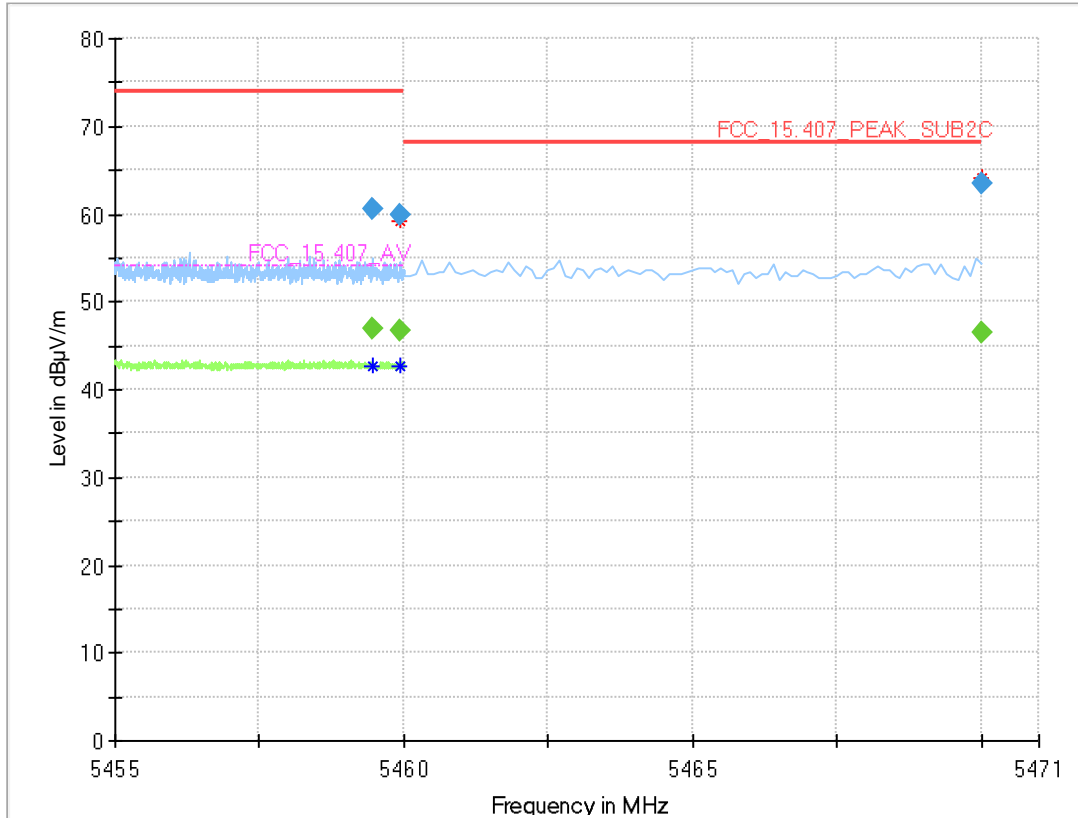

Final_Result

Frequency (MHz)	MaxPeak (dBµV/m)	CAverage (dBµV/m)	Limit (dBµV/m)	Margin (dB)	Meas. Time (ms)	Bandwidth (kHz)	Height (cm)	Pol	Azimuth (deg)	Elevation (deg)	Corr. (dB/m)
5459.465	---	46.8	54.00	7.16	1000.0	1000.000	150.0	H	-171.0	79.0	15.9
5459.465	60.5	---	74.00	13.50	1000.0	1000.000	150.0	H	-171.0	79.0	15.9
5459.935	---	46.8	54.00	7.21	1000.0	1000.000	150.0	H	-169.0	82.0	15.9
5459.935	59.9	---	74.00	14.13	1000.0	1000.000	150.0	H	-169.0	82.0	15.9
5470.000	---	46.6	---	---	1000.0	1000.000	150.0	H	-174.0	84.0	15.7
5470.000	63.5	---	68.20	4.72	1000.0	1000.000	150.0	H	-174.0	84.0	15.7

Radio Technology = WLAN n 40 MHz, Operating Frequency = low, Subband = U-NII-2C (S02_161_AG01)

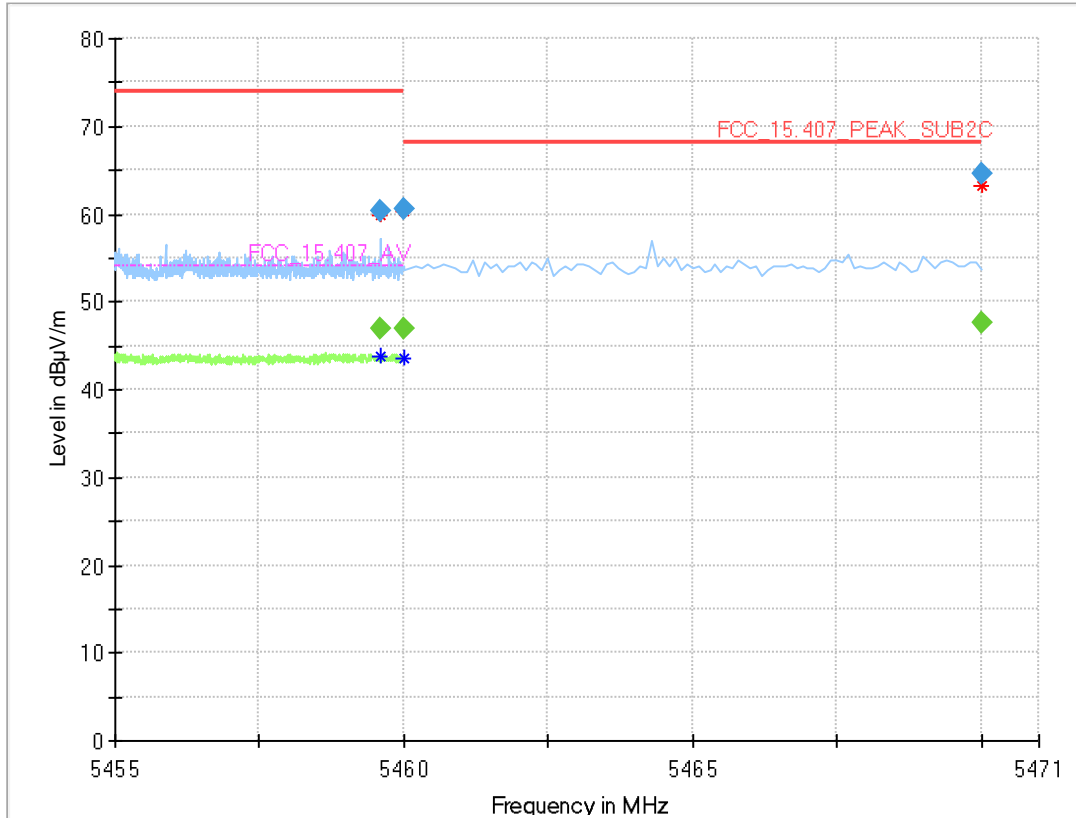

Final Result

Frequency (MHz)	MaxPeak (dBµV/m)	CAverage (dBµV/m)	Limit (dBµV/m)	Margin (dB)	Meas. Time (ms)	Bandwidth (kHz)	Height (cm)	Pol	Azimuth (deg)	Elevation (deg)	Corr. (dB/m)
5459.605	---	46.9	54.00	7.06	1000.0	1000.000	150.0	H	-46.0	80.0	15.9
5459.605	60.3	---	74.00	13.74	1000.0	1000.000	150.0	H	-46.0	80.0	15.9
5460.000	---	46.8	54.00	7.15	1000.0	1000.000	150.0	H	-46.0	94.0	15.9
5460.000	60.6	---	74.00	13.43	1000.0	1000.000	150.0	H	-46.0	94.0	15.9
5470.000	---	47.5	---	---	1000.0	1000.000	150.0	H	-41.0	84.0	15.7
5470.000	64.7	---	68.20	3.52	1000.0	1000.000	150.0	H	-41.0	84.0	15.7

5.3.5 TEST EQUIPMENT USED

- Radiated Emissions FAR 5 GHz FCC

6 TEST EQUIPMENT

6.1 TEST EQUIPMENT HARDWARE

- 1 R&S TS8997
2.4 and 5 GHz Bands Conducted Test Lab

Ref.No.	Device Name	Description	Manufacturer	Serial Number	Last Calibration	Calibration Due
1.1	Opus10 TPR (8253.00)	T/P Logger 13	Lufft Mess- und Regeltechnik GmbH	13936	2023-12	2025-12
1.2	Opus10 THI (8152.00)	T/H Logger 14	Lufft Mess- und Regeltechnik GmbH	13993	2023-12	2025-12
1.3	FSV30	Signal Analyzer 10 Hz - 30 GHz	Rohde & Schwarz	103005	2023-08	2025-08
1.4	FSW43	Signal Analyser	Rohde & Schwarz GmbH & Co. KG	102013	2023-07	2025-07
1.5	OSP120	Contains Power Meter and Switching Unit OSP-B157W8 PLUS	Rohde & Schwarz	101158	2021-08	2024-08
1.6	CS-RUB6	Rubidium Frequency Standard	Rohde & Schwarz GmbH & Co. KG	100321	2023-10	2024-10

2 Radiated Emissions FAR 5 GHz FCC
 Radiated Emissions Tests for 5 GHz bands in a fully anechoic room

Ref.No.	Device Name	Description	Manufacturer	Serial Number	Last Calibration	Calibration Due
2.1	Opus10 TPR (8253.00)	T/P Logger 13	Lufft Mess- und Regeltechnik GmbH	13936	2023-12	2025-12
2.2	Innco Systems CO3000	Controller for bore sight mast FAC	innco systems GmbH	CO3000/1460/54740522/P	N/A	N/A
2.3	AMF-7D00101800-30-10P-R	Broadband Amplifier 100 MHz - 18 GHz	Miteq		N/A	N/A
2.4	Anechoic Chamber 03	FAR, 8.80m x 4.60m x 4.05m (l x w x h)	Albatross Projects	P26971-647-001-PRB	N/A	N/A
2.5	Fluke 177	Digital Multimeter 03 (Multimeter)	Fluke Europe B.V.	86670383	2023-08	2025-08
2.6	JS4-18002600-32-5P	Broadband Amplifier 18 GHz - 26 GHz	Miteq	849785	N/A	N/A
2.7	FSW43	Spectrum Analyzer	Rohde & Schwarz GmbH & Co. KG	103779	2023-04	2025-04
2.8	EP 1200/B, NA/B1	AC Source, Amplifier with integrated variable Oscillator	Spitzenberger & Spies GmbH & Co. KG	B6278	N/A	N/A
2.9	3160-09	Standard Gain / Pyramidal Horn Antenna 26.5 GHz	EMCO Elektronik GmbH	00083069	N/A	N/A
2.10	WHKX 7.0/18G-8SS	High Pass Filter	Wainwright Instruments GmbH	09	N/A	N/A
2.11	MA3000/0800-XP-ET-compact	Bore Sight Antenna Mast	innco systems GmbH	9210522	N/A	N/A
2.12	TT 1.5 WI	Turn Table	Maturo GmbH	-	N/A	N/A
2.13	3160-10	Standard Gain / Pyramidal Horn Antenna 40 GHz	EMCO Elektronik GmbH	00086675	N/A	N/A
2.14	Opus 20 THI (8120.00)	ThermoHygro Datalogger	Lufft Mess- und Regeltechnik GmbH	115.0318.0802.033	2023-08	2025-08
2.15	TD1.5-10kg	EUT Tilt Device (Rohacell)	Maturo GmbH	TD1.5-10kg/024/3790709	N/A	N/A
2.16	AFS42-00101800-25-S-42	Broadband Amplifier 25 MHz - 18 GHz	Miteq	2035324	N/A	N/A
2.17	HF 907	Double-ridged horn	Rohde & Schwarz	102444	2021-09	2024-09

3 Radiated Emissions SAC H-Field
 Radiated emission tests in the H-Field in a semi anechoic room

Ref.No.	Device Name	Description	Manufacturer	Serial Number	Last Calibration	Calibration Due
3.1	N5000/NP	Filter for EUT, 2 Lines, 250 V, 16 A	ETS-LINDGREN	241515	N/A	N/A
3.2	Opus10 TPR (8253.00)	T/P Logger 13	Lufft Mess- und Regeltechnik GmbH	13936	2023-12	2025-12
3.3	ESW44	EMI Receiver / Spectrum Analyzer	Rohde & Schwarz GmbH & Co. KG	101603	2024-03	2026-03
3.4	Anechoic Chamber 01	SAC/FAR, 10.58 m x 6.38 m x 6.00 m	Frankonia Germany EMC Solution GmbH	none	N/A	N/A
3.5	Fluke 177	Digital Multimeter 03 (Multimeter)	Fluke Europe B.V.	86670383	2023-08	2025-08
3.6	Opus10 THI (8152.00)	T/H Logger 10	Lufft Mess- und Regeltechnik GmbH	12488	2023-12	2025-12
3.7	EP 1200/B, NA/B1	AC Source, Amplifier with integrated variable Oscillator	Spitzenberger & Spies GmbH & Co. KG	B6278	N/A	N/A
3.8	DS 420S	Turn Table 2 m diameter	HD GmbH	420/573/99	N/A	N/A
3.9	HFH2-Z2	Loop Antenna + 3 Axis Tripod	Rohde & Schwarz GmbH & Co. KG	829324/006	2024-04	2027-04
3.10	CS-RUB6	Rubidium Frequency Standard	Rohde & Schwarz GmbH & Co. KG	100321	2023-10	2024-10

4 Radiated Emissions SAC up to 1 GHz
Radiated emission tests up to 1 GHz in a semi anechoic room

Ref.No.	Device Name	Description	Manufacturer	Serial Number	Last Calibration	Calibration Due
4.1	N5000/NP	Filter for EUT, 2 Lines, 250 V, 16 A	ETS-LINDGREN	241515	N/A	N/A
4.2	Opus10 TPR (8253.00)	T/P Logger 13	Lufft Mess- und Regeltechnik GmbH	13936	2023-12	2025-12
4.3	ESW44	EMI Receiver / Spectrum Analyzer	Rohde & Schwarz GmbH & Co. KG	101603	2024-03	2026-03
4.4	Anechoic Chamber 01	SAC/FAR, 10.58 m x 6.38 m x 6.00 m	Frankonia Germany EMC Solution GmbH	none	N/A	N/A
4.5	HL 562 ULTRALOG	Biconical-log- per antenna (30 MHz - 3 GHz) with HL 562E biconicals	Rohde & Schwarz GmbH & Co. KG	830547/003	2021-09	2024-09
4.6	Fluke 177	Digital Multimeter 03 (Multimeter)	Fluke Europe B.V.	86670383	2023-08	2025-08
4.7	Opus10 THI (8152.00)	T/H Logger 10	Lufft Mess- und Regeltechnik GmbH	12488	2023-12	2025-12
4.8	EP 1200/B, NA/B1	AC Source, Amplifier with integrated variable Oscillator	Spitzenberger & Spies GmbH & Co. KG	B6278	N/A	N/A
4.9	DS 420S	Turn Table 2 m diameter	HD GmbH	420/573/99	N/A	N/A
4.10	CS-RUB6	Rubidium Frequency Standard	Rohde & Schwarz GmbH & Co. KG	100321	2023-10	2024-10
4.11	AM 4.0	Antenna Mast 4 m	Maturo GmbH	AM4.0/180/1192 0513	N/A	N/A

The calibration interval is the time interval between "Last Calibration" and "Calibration Due"

6.2 TEST EQUIPMENT SOFTWARE

Semi-Anechoic Chamber:	
Software	Version
EMC32 Measurement Software	10.60.10
INNCO Mast Controller	1.02.62
INNCO Mast Height	34.10
INNCO Mast Elevation	36.11
MATURO Controller	1.24
MATURO Mast	12.19
MATURO Turn-Table	30.10
Fully-Anechoic Chamber:	
Software	Version
EMC32 Measurement Software	10.60.10
MATURO Controller	1.30
MATURO Turn-Unit	11.10
MATURO Mast	12.10
MATURO Turntable	12.11
INNCO Controller	1.03.02
INNCO Mast Height	34.10
INNCO Mast Elevation	36.11
TS 8997	
WMS32 Measurement Software	11.60.00 (till 2024-03-19), 11.70.00 + Hotfix 01
Conducted AC Emissions:	
Software	Version
EMC32 Measurement Software	10.60.20

7 ANTENNA FACTORS, CABLE LOSS AND SAMPLE CALCULATIONS

This chapter contains the antenna factors with their corresponding path loss of the used measurement path for all antennas as well as the insertion loss of the LISN.

7.1 LISN R&S ESH3-Z5 (150 KHZ – 30 MHZ)

Frequency MHz	Corr. dB	LISN insertion loss ESH3-Z5 dB	cable loss (incl. 10 dB atten- uator) dB
0.15	10.1	0.1	10.0
5	10.3	0.1	10.2
7	10.5	0.2	10.3
10	10.5	0.2	10.3
12	10.7	0.3	10.4
14	10.7	0.3	10.4
16	10.8	0.4	10.4
18	10.9	0.4	10.5
20	10.9	0.4	10.5
22	11.1	0.5	10.6
24	11.1	0.5	10.6
26	11.2	0.5	10.7
28	11.2	0.5	10.7
30	11.3	0.5	10.8

Sample calculation

$$U_{\text{LISN}} \text{ (dB } \mu\text{V)} = U \text{ (dB } \mu\text{V)} + \text{Corr. (dB)}$$

U = Receiver reading

LISN Insertion loss = Voltage Division Factor of LISN

Corr. = sum of single correction factors of used LISN, cables, switch units (if used)

Linear interpolation will be used for frequencies in between the values in the table.

7.2 ANTENNA R&S HFH2-Z2 (9 KHZ – 30 MHZ)

Frequency MHz	AF HFH- Z2) dB (1/m)	Corr. dB	cable loss 1 (inside chamber) dB	cable loss 2 (outside chamber) dB	cable loss 3 (switch unit) dB	cable loss 4 (to receiver) dB	distance corr. (-40 dB/ decade) dB	d _{Limit} (meas. distance (limit) m	d _{used} (meas. distance (used) m
0.009	20.50	-79.6	0.1	0.1	0.1	0.1	-80	300	3
0.01	20.45	-79.6	0.1	0.1	0.1	0.1	-80	300	3
0.015	20.37	-79.6	0.1	0.1	0.1	0.1	-80	300	3
0.02	20.36	-79.6	0.1	0.1	0.1	0.1	-80	300	3
0.025	20.38	-79.6	0.1	0.1	0.1	0.1	-80	300	3
0.03	20.32	-79.6	0.1	0.1	0.1	0.1	-80	300	3
0.05	20.35	-79.6	0.1	0.1	0.1	0.1	-80	300	3
0.08	20.30	-79.6	0.1	0.1	0.1	0.1	-80	300	3
0.1	20.20	-79.6	0.1	0.1	0.1	0.1	-80	300	3
0.2	20.17	-79.6	0.1	0.1	0.1	0.1	-80	300	3
0.3	20.14	-79.6	0.1	0.1	0.1	0.1	-80	300	3
0.49	20.12	-79.6	0.1	0.1	0.1	0.1	-80	300	3
0.490001	20.12	-39.6	0.1	0.1	0.1	0.1	-40	30	3
0.5	20.11	-39.6	0.1	0.1	0.1	0.1	-40	30	3
0.8	20.10	-39.6	0.1	0.1	0.1	0.1	-40	30	3
1	20.09	-39.6	0.1	0.1	0.1	0.1	-40	30	3
2	20.08	-39.6	0.1	0.1	0.1	0.1	-40	30	3
3	20.06	-39.6	0.1	0.1	0.1	0.1	-40	30	3
4	20.05	-39.5	0.2	0.1	0.1	0.1	-40	30	3
5	20.05	-39.5	0.2	0.1	0.1	0.1	-40	30	3
6	20.02	-39.5	0.2	0.1	0.1	0.1	-40	30	3
8	19.95	-39.5	0.2	0.1	0.1	0.1	-40	30	3
10	19.83	-39.4	0.2	0.1	0.2	0.1	-40	30	3
12	19.71	-39.4	0.2	0.1	0.2	0.1	-40	30	3
14	19.54	-39.4	0.2	0.1	0.2	0.1	-40	30	3
16	19.53	-39.3	0.3	0.1	0.2	0.1	-40	30	3
18	19.50	-39.3	0.3	0.1	0.2	0.1	-40	30	3
20	19.57	-39.3	0.3	0.1	0.2	0.1	-40	30	3
22	19.61	-39.3	0.3	0.1	0.2	0.1	-40	30	3
24	19.61	-39.3	0.3	0.1	0.2	0.1	-40	30	3
26	19.54	-39.3	0.3	0.1	0.2	0.1	-40	30	3
28	19.46	-39.2	0.3	0.1	0.3	0.1	-40	30	3
30	19.73	-39.1	0.4	0.1	0.3	0.1	-40	30	3

Sample calculation

$$E \text{ (dB } \mu\text{V/m)} = U \text{ (dB } \mu\text{V)} + \text{AF (dB 1/m)} + \text{Corr. (dB)}$$

U = Receiver reading

AF = Antenna factor

Corr. = sum of single correction factors of used cables, switch unit, distance correction, amplifier (if applicable)

distance correction = $-40 * \text{LOG} (d_{\text{Limit}} / d_{\text{used}})$

Linear interpolation will be used for frequencies in between the values in the table.

Table shows an extract of values

7.3 ANTENNA R&S HL562 (30 MHz – 1 GHz)

($d_{Limit} = 3\text{ m}$)

Frequency	AF R&S HL562	Corr.
MHz	dB (1/m)	dB
30	18.6	0.6
50	6.0	0.9
100	9.7	1.2
150	7.9	1.6
200	7.6	1.9
250	9.5	2.1
300	11.0	2.3
350	12.4	2.6
400	13.6	2.9
450	14.7	3.1
500	15.6	3.2
550	16.3	3.5
600	17.2	3.5
650	18.1	3.6
700	18.5	3.6
750	19.1	4.1
800	19.6	4.1
850	20.1	4.4
900	20.8	4.7
950	21.1	4.8
1000	21.6	4.9

cable loss 1 (inside chamber)	cable loss 2 (outside chamber)	cable loss 3 (switch unit)	cable loss 4 (to receiver)	distance corr. (-20 dB/decade)	d_{Limit} (meas. distance (limit))	d_{used} (meas. distance (used))
dB	dB	dB	dB	dB	m	m
0.29	0.04	0.23	0.02	0.0	3	3
0.39	0.09	0.32	0.08	0.0	3	3
0.56	0.14	0.47	0.08	0.0	3	3
0.73	0.20	0.59	0.12	0.0	3	3
0.84	0.21	0.70	0.11	0.0	3	3
0.98	0.24	0.80	0.13	0.0	3	3
1.04	0.26	0.89	0.15	0.0	3	3
1.18	0.31	0.96	0.13	0.0	3	3
1.28	0.35	1.03	0.19	0.0	3	3
1.39	0.38	1.11	0.22	0.0	3	3
1.44	0.39	1.20	0.19	0.0	3	3
1.55	0.46	1.24	0.23	0.0	3	3
1.59	0.43	1.29	0.23	0.0	3	3
1.67	0.34	1.35	0.22	0.0	3	3
1.67	0.42	1.41	0.15	0.0	3	3
1.87	0.54	1.46	0.25	0.0	3	3
1.90	0.46	1.51	0.25	0.0	3	3
1.99	0.60	1.56	0.27	0.0	3	3
2.14	0.60	1.63	0.29	0.0	3	3
2.22	0.60	1.66	0.33	0.0	3	3
2.23	0.61	1.71	0.30	0.0	3	3

($d_{Limit} = 10\text{ m}$)

30	18.6	-9.9
50	6.0	-9.6
100	9.7	-9.2
150	7.9	-8.8
200	7.6	-8.6
250	9.5	-8.3
300	11.0	-8.1
350	12.4	-7.9
400	13.6	-7.6
450	14.7	-7.4
500	15.6	-7.2
550	16.3	-7.0
600	17.2	-6.9
650	18.1	-6.9
700	18.5	-6.8
750	19.1	-6.3
800	19.6	-6.3
850	20.1	-6.0
900	20.8	-5.8
950	21.1	-5.6
1000	21.6	-5.6

0.29	0.04	0.23	0.02	-10.5	10	3
0.39	0.09	0.32	0.08	-10.5	10	3
0.56	0.14	0.47	0.08	-10.5	10	3
0.73	0.20	0.59	0.12	-10.5	10	3
0.84	0.21	0.70	0.11	-10.5	10	3
0.98	0.24	0.80	0.13	-10.5	10	3
1.04	0.26	0.89	0.15	-10.5	10	3
1.18	0.31	0.96	0.13	-10.5	10	3
1.28	0.35	1.03	0.19	-10.5	10	3
1.39	0.38	1.11	0.22	-10.5	10	3
1.44	0.39	1.20	0.19	-10.5	10	3
1.55	0.46	1.24	0.23	-10.5	10	3
1.59	0.43	1.29	0.23	-10.5	10	3
1.67	0.34	1.35	0.22	-10.5	10	3
1.67	0.42	1.41	0.15	-10.5	10	3
1.87	0.54	1.46	0.25	-10.5	10	3
1.90	0.46	1.51	0.25	-10.5	10	3
1.99	0.60	1.56	0.27	-10.5	10	3
2.14	0.60	1.63	0.29	-10.5	10	3
2.22	0.60	1.66	0.33	-10.5	10	3
2.23	0.61	1.71	0.30	-10.5	10	3

Sample calculation

$$E \text{ (dB } \mu\text{V/m)} = U \text{ (dB } \mu\text{V)} + \text{AF (dB 1/m)} + \text{Corr. (dB)}$$

U = Receiver reading

AF = Antenna factor

Corr. = sum of single correction factors of used cables, switch unit, distance correction, amplifier (if applicable)

distance correction = $-20 * \text{LOG} (d_{Limit} / d_{used})$

Linear interpolation will be used for frequencies in between the values in the table.

Tables show an extract of values.

7.4 ANTENNA R&S HF907 (1 GHZ – 18 GHZ)

Frequency	AF R&S HF907	Corr.
MHz	dB (1/m)	dB
1000	24.4	-19.4
2000	28.5	-17.4
3000	31.0	-16.1
4000	33.1	-14.7
5000	34.4	-13.7
6000	34.7	-12.7
7000	35.6	-11.0

cable loss 1 (relay + cable inside chamber)	cable loss 2 (outside chamber)	cable loss 3 (switch unit, attenuator & pre-amp)	cable loss 4 (to receiver)
dB	dB	dB	dB
0.99	0.31	-21.51	0.79
1.44	0.44	-20.63	1.38
1.87	0.53	-19.85	1.33
2.41	0.67	-19.13	1.31
2.78	0.86	-18.71	1.40
2.74	0.90	-17.83	1.47
2.82	0.86	-16.19	1.46

Frequency	AF R&S HF907	Corr.
MHz	dB (1/m)	dB
3000	31.0	-23.4
4000	33.1	-23.3
5000	34.4	-21.7
6000	34.7	-21.2
7000	35.6	-19.8

cable loss 1 (relay inside chamber)	cable loss 2 (inside chamber)	cable loss 3 (outside chamber)	cable loss 4 (switch unit, attenuator & pre-amp)	cable loss 5 (to receiver)	used for FCC 15.247
dB	dB	dB	dB	dB	
0.47	1.87	0.53	-27.58	1.33	
0.56	2.41	0.67	-28.23	1.31	
0.61	2.78	0.86	-27.35	1.40	
0.58	2.74	0.90	-26.89	1.47	
0.66	2.82	0.86	-25.58	1.46	

Frequency	AF R&S HF907	Corr.
MHz	dB (1/m)	dB
7000	35.6	-57.3
8000	36.3	-56.3
9000	37.1	-55.3
10000	37.5	-56.2
11000	37.5	-55.3
12000	37.6	-53.7
13000	38.2	-53.5
14000	39.9	-56.3
15000	40.9	-54.1
16000	41.3	-54.1
17000	42.8	-54.4
18000	44.2	-54.7

cable loss 1 (relay inside chamber)	cable loss 2 (High Pass)	cable loss 3 (pre-amp)	cable loss 4 (inside chamber)	cable loss 5 (outside chamber)	cable loss 6 (to receiver)
dB	dB	dB	dB	dB	dB
0.56	1.28	-62.72	2.66	0.94	1.46
0.69	0.71	-61.49	2.84	1.00	1.53
0.68	0.65	-60.80	3.06	1.09	1.60
0.70	0.54	-61.91	3.28	1.20	1.67
0.80	0.61	-61.40	3.43	1.27	1.70
0.84	0.42	-59.70	3.53	1.26	1.73
0.83	0.44	-59.81	3.75	1.32	1.83
0.91	0.53	-63.03	3.91	1.40	1.77
0.98	0.54	-61.05	4.02	1.44	1.83
1.23	0.49	-61.51	4.17	1.51	1.85
1.36	0.76	-62.36	4.34	1.53	2.00
1.70	0.53	-62.88	4.41	1.55	1.91

Sample calculation

$$E \text{ (dB } \mu\text{V/m)} = U \text{ (dB } \mu\text{V)} + \text{AF (dB 1/m)} + \text{Corr. (dB)}$$

U = Receiver reading

AF = Antenna factor

Corr. = sum of single correction factors of used cables, switch unit, distance correction, amplifier (if applicable)

Linear interpolation will be used for frequencies in between the values in the table.

Tables show an extract of values.

7.5 ANTENNA EMCO 3160-09 (18 GHZ – 26.5 GHZ)

Frequency MHz	AF EMCO 3160-09 dB (1/m)	Corr. dB	cable loss 1 (inside chamber) dB	cable loss 2 (pre- amp) dB	cable loss 3 (inside chamber) dB	cable loss 4 (switch unit) dB	cable loss 5 (to receiver) dB
18000	40.2	-23.5	0.72	-35.85	6.20	2.81	2.65
18500	40.2	-23.2	0.69	-35.71	6.46	2.76	2.59
19000	40.2	-22.0	0.76	-35.44	6.69	3.15	2.79
19500	40.3	-21.3	0.74	-35.07	7.04	3.11	2.91
20000	40.3	-20.3	0.72	-34.49	7.30	3.07	3.05
20500	40.3	-19.9	0.78	-34.46	7.48	3.12	3.15
21000	40.3	-19.1	0.87	-34.07	7.61	3.20	3.33
21500	40.3	-19.1	0.90	-33.96	7.47	3.28	3.19
22000	40.3	-18.7	0.89	-33.57	7.34	3.35	3.28
22500	40.4	-19.0	0.87	-33.66	7.06	3.75	2.94
23000	40.4	-19.5	0.88	-33.75	6.92	3.77	2.70
23500	40.4	-19.3	0.90	-33.35	6.99	3.52	2.66
24000	40.4	-19.8	0.88	-33.99	6.88	3.88	2.58
24500	40.4	-19.5	0.91	-33.89	7.01	3.93	2.51
25000	40.4	-19.3	0.88	-33.00	6.72	3.96	2.14
25500	40.5	-20.4	0.89	-34.07	6.90	3.66	2.22
26000	40.5	-21.3	0.86	-35.11	7.02	3.69	2.28
26500	40.5	-21.1	0.90	-35.20	7.15	3.91	2.36

Sample calculation

$$E \text{ (dB } \mu\text{V/m)} = U \text{ (dB } \mu\text{V)} + AF \text{ (dB 1/m)} + Corr. \text{ (dB)}$$

U = Receiver reading

AF = Antenna factor

Corr. = sum of single correction factors of used cables, switch unit, distance correction, amplifier (if applicable)

Linear interpolation will be used for frequencies in between the values in the table.

Table shows an extract of values.

7.6 ANTENNA EMCO 3160-10 (26.5 GHZ – 40 GHZ)

Frequency GHz	AF EMCO 3160-10 dB (1/m)	Corr. dB	cable loss 1 (inside chamber) dB	cable loss 2 (outside chamber) dB	cable loss 3 (switch unit) dB	cable loss 4 (to receiver) dB	distance corr. (-20 dB/ decade) dB	d _{Limit} (meas. distance (limit) m	d _{used} (meas. distance (used) m
26.5	43.4	-11.2	4.4				-9.5	3	1.0
27.0	43.4	-11.2	4.4				-9.5	3	1.0
28.0	43.4	-11.1	4.5				-9.5	3	1.0
29.0	43.5	-11.0	4.6				-9.5	3	1.0
30.0	43.5	-10.9	4.7				-9.5	3	1.0
31.0	43.5	-10.8	4.7				-9.5	3	1.0
32.0	43.5	-10.7	4.8				-9.5	3	1.0
33.0	43.6	-10.7	4.9				-9.5	3	1.0
34.0	43.6	-10.6	5.0				-9.5	3	1.0
35.0	43.6	-10.5	5.1				-9.5	3	1.0
36.0	43.6	-10.4	5.1				-9.5	3	1.0
37.0	43.7	-10.3	5.2				-9.5	3	1.0
38.0	43.7	-10.2	5.3				-9.5	3	1.0
39.0	43.7	-10.2	5.4				-9.5	3	1.0
40.0	43.8	-10.1	5.5				-9.5	3	1.0

Sample calculation

$$E \text{ (dB } \mu\text{V/m)} = U \text{ (dB } \mu\text{V)} + \text{AF (dB 1/m)} + \text{Corr. (dB)}$$

U = Receiver reading

AF = Antenna factor

Corr. = sum of single correction factors of used cables, switch unit, distance correction, amplifier (if applicable)

Linear interpolation will be used for frequencies in between the values in the table.

distance correction = $-20 * \text{LOG} (d_{\text{Limit}} / d_{\text{used}})$

Linear interpolation will be used for frequencies in between the values in the table.

Table shows an extract of values.

8 MEASUREMENT UNCERTAINTIES

Test Case	Parameter	Uncertainty
AC Power Line	Power	± 3.4 dB
Field Strength of spurious radiation	Power	± 5.5 dB
6 dB / 26 dB / 99% Bandwidth	Power Frequency	± 2.9 dB ± 11.2 kHz
Conducted Output Power	Power	± 2.2 dB
Band Edge Compliance	Power Frequency	± 2.2 dB ± 11.2 kHz
Frequency Stability	Frequency	± 25 Hz
Power Spectral Density	Power	± 2.2 dB

The measurement uncertainties for all parameters are calculated with an expansion factor (coverage factor) $k = 1.96$. This means, that the true value is in the corresponding interval with a probability of 95 %.

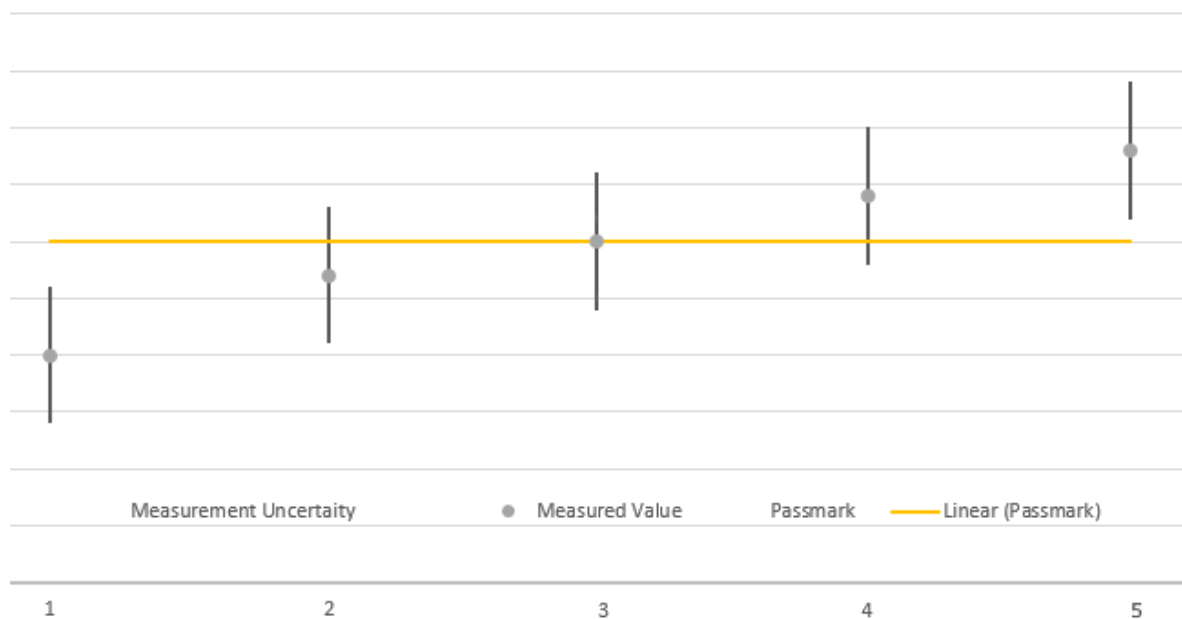

The verdicts in this test report are given according the above diagram:

Case	Measured Value	Uncertainty Range	Verdict
1	below pass mark	below pass mark	Passed
2	below pass mark	within pass mark	Passed
3	on pass mark	within pass mark	Passed
4	above pass mark	within pass mark	Failed
5	above pass mark	above pass mark	Failed

That means, the laboratory applies, as decision rule (see ISO/IEC 17025:2017), the so-called shared risk principle.



9 PHOTO REPORT

Please see separate photo report.

*****END OF TEST REPORT*****