

# EMMY-W1 Antenna reference design

<b>Topic :</b>	<b>EMMY-W1 Antenna reference design</b>		
<b>Doc.No:</b>	UBX-16015910		
<b>Revision</b>	R01		
	Date:	Name	Signature
<b>Created</b>	01-Jul-2016	Stefano Bianconi	sbia
<b>Checked</b>			
<b>Released</b>			

We reserve all rights in this document and in the information contained therein. Reproduction, use or disclosure to third parties without express authority is strictly forbidden.

© 2016 u-blox AG

## 1 Scope

This document defines the essential specifications necessary to implement the EMMY-W1 antenna reference designs. The information contained herein and its references should be sufficient to guide a skilled person in an attempt to implement the design on a host carrier. It will provide the designer with PCB layout details and expected performance specifications.

The document supports the four different PCB designs for Wi-Fi:

- Two connector-based designs for the use of external antennas (one for each antenna pin of the module)
- Two designs based on SMD antennas (one for each antenna pin of the module)

This document also supports general guidelines for the design of the NFC interface.

## 2 FCC/IC ID reference

Model	FCC ID	IC ID
EMMY-W161	XPYEMMYW161	8595A-EMMYW161
EMMY-W163	XPYEMMYW163	8595A-EMMYW163

**Table 1: FCC and IC IDs for different models of EMMY-W1 series**

### 3 General description

When using the EMMY-W1 together with this antenna reference design, the circuit trace layout must be made in strict compliance with the instructions below.

All the components placed on each RF trace must be kept as indicated in the reference design, even if not used. The PCB areas of unused reference designs must be flooded with ground.

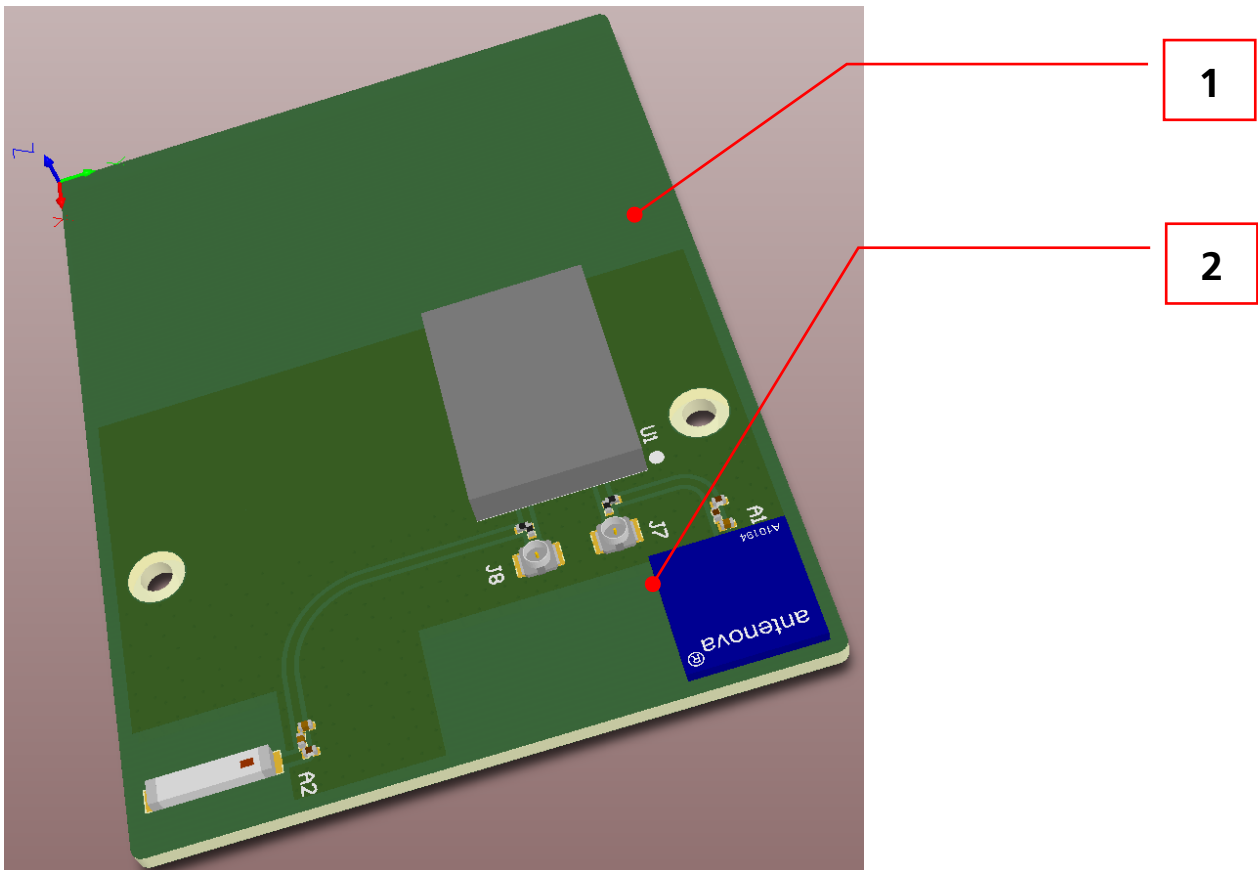

Figure 1: Antenna Reference design embedded in a host carrier PCB

Reference	Description
1	Host carrier PCB (light green)
2	Antenna reference design (dark green)

### 3.1 Floor plan and PCB stack-up

This section describes where the critical components are positioned on the reference design. It also presents the stack-up of the four layers of the PCB.

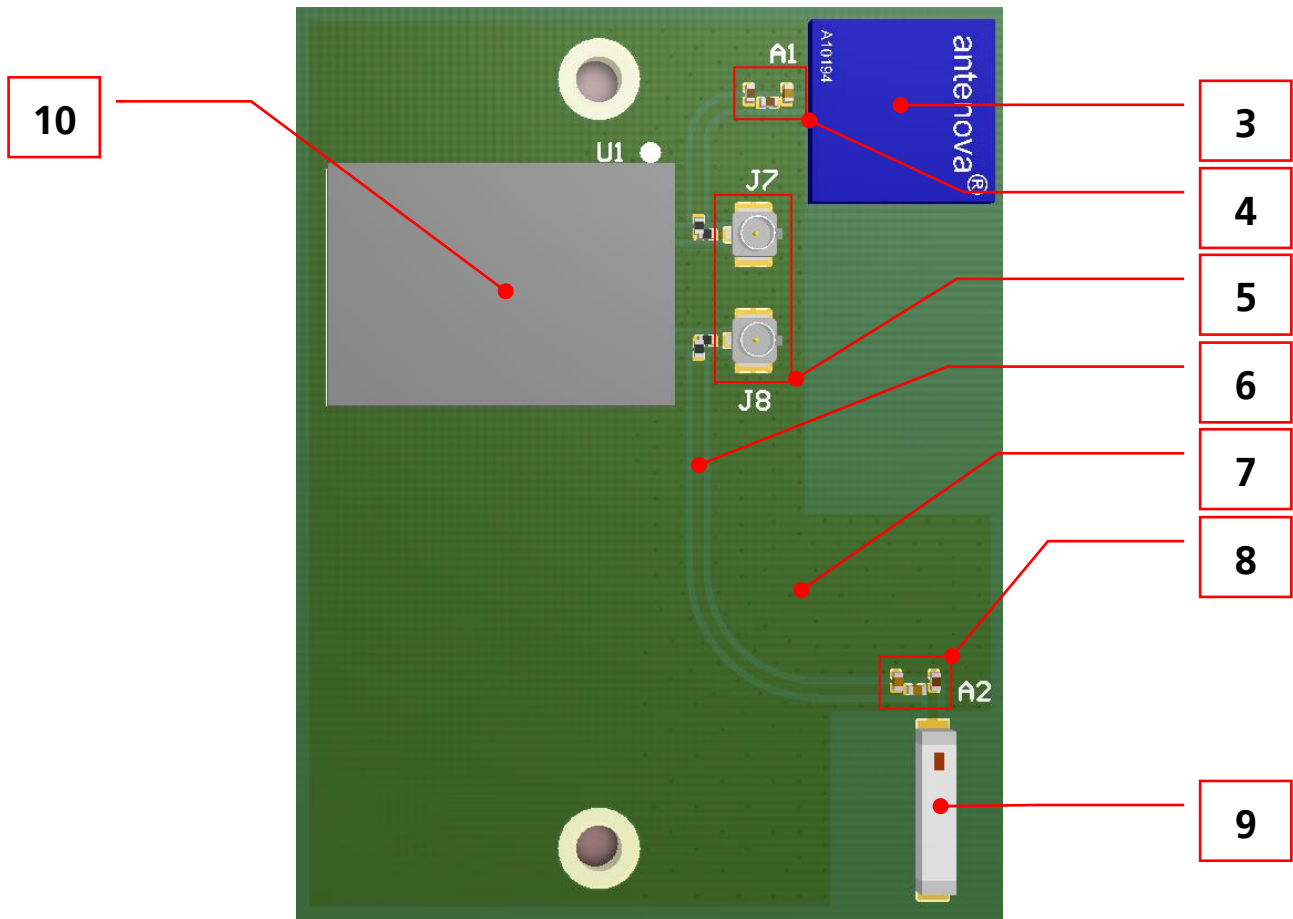

Figure 2: EMMY-W1 antenna reference design

Reference	Description
3	SMD antenna
4	Antenna impedance matching network
5	Connectors for external antenna
6	Antenna coplanar microstrip, matched to 50 $\Omega$
7	Top layer GND-plane
8	Antenna impedance matching network
9	SMD antenna
10	ELLA-W1 module

## 3.2 PCB stack-up

The stack-up used in the reference design is specified in Table 2.

PCB Layer	Material	Thickness
Soldermask Top	Generic LPI Soldermask	25 $\mu\text{m}$
Top	Copper Foil	35 $\mu\text{m}$
Dielectric	Pre-preg 2x7628	360 $\mu\text{m}$
L2	Copper Foil	35 $\mu\text{m}$
Dielectric	Core	700 $\mu\text{m}$ +/-10%
L3	Copper Foil	35 $\mu\text{m}$
Dielectric	Pre-preg 2x7628	360 $\mu\text{m}$
Bottom	Copper Foil	35 $\mu\text{m}$
Soldermask Bottom	Generic LPI Soldermask	25 $\mu\text{m}$

**Table 2: Stack-up of EVK-EMMY-W1**

### 3.2.1 RF trace specification

The 50  $\Omega$  coplanar micro-strip dimensions used in these reference designs are stated in Figure 3 and Table 3.

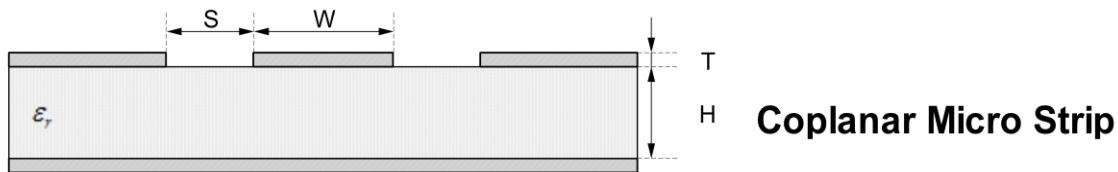

**Figure 3: Coplanar micro-strip dimension specification**

Item	Value
S	400 $\mu\text{m}$
W	600 $\mu\text{m}$
T	35 $\mu\text{m}$
H	360 $\mu\text{m}$

**Table 3: Coplanar micro-strip specification**

## 3.3 Mechanical dimensions

The Mechanical dimensions and position of the components are specified in Figure 4.

The layers beneath the 'top layer' have the same dimensions and are filled with ground. No RF traces are routed in those layers.

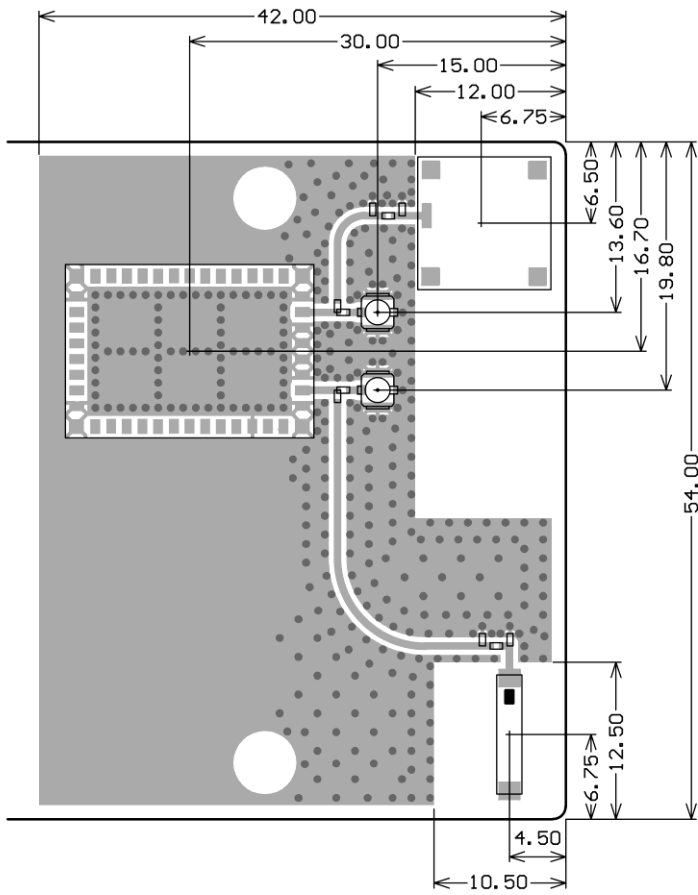

Figure 4: Mechanical dimensions of EVK-EMMY-W1, top layer

## 4 Reference designs for antenna pin 1

This section describes the available designs for the antenna pin 1 of the EMMY-W1 modules.

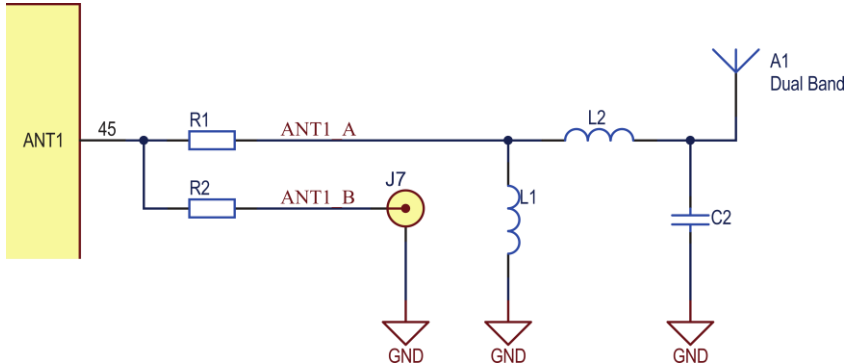

Figure 5: Reference schematic for antenna pin 1

### 4.1 Internal antenna

The reference design with internal antenna uses the SMD Antenna type A10194 dual band antenna that is connected to the module RF-port via a coplanar micro-strip transmission line.

#### 4.1.1 Bill of materials

Reference designator	Description	Manufacturer	P/N
A1	Antenna CHIP 2.45 & 5 GHz	Antenna	A10194
L1	IND, Multilayer Ceramic, 10nH, +/-5%, 300mA, SMD 0402	Johanson Technology	L-07C10NV6ST
L2	IND, Multilayer Ceramic, 1nH, +/-0.3nH, 300mA, SMD 0402	Johanson Technology	L-07C1N0SV6T
C2	CAP, CER, 0.2pF, +/-0.1pF, COG, 50V, SMD 0402	Johanson Technology	500R07S0R2BV4
R1	0 $\Omega$ resistor, 0402	Generic	-
R2	Do not Assembly	-	-
J7	Do Not Assembly	-	-

#### 4.1.2 Antenna characteristics

Parameter	Low band	High band	Unit
Frequency Range	2.4 – 2.5	4.9 – 5.875	GHz
Peak Gain	1.8	4.1	dBi
VSWR	< 1.4:1	< 1.8:1	-
Efficiency	>75	>60	%
Polarisation	Linear		-
Radiation pattern	Omnidirectional		-
Temperature range	-40 to +85		°C
Impedance	50		$\Omega$
Dimension (L x W x H)	10.0 x 10.0 x 0.9		mm

## 4.2 External antenna

The reference design with external antenna uses the micro coaxial connector that is connected to the external antenna via a 50  $\Omega$  pigtail. See section 6 for a list of available external antennas.

### 4.2.1 Bill of materials

Reference designator	Description	Manufacturer	P/N
A1	Do Not Assembly	-	-
L1	Do Not Assembly	-	-
L2	Do Not Assembly	-	-
C2	Do Not Assembly	-	-
R1	Do Not Assembly	-	-
R2	0 $\Omega$ resistor, 0402	Generic	-
J7	Coaxial Connector, 0 – 6 GHz, SMD	Hirose	U.FL-R-SMT-1(10)

## 5 Reference designs for antenna pin 2

This section describes the available designs for the antenna pin 2 of the EMMY-W1 modules.

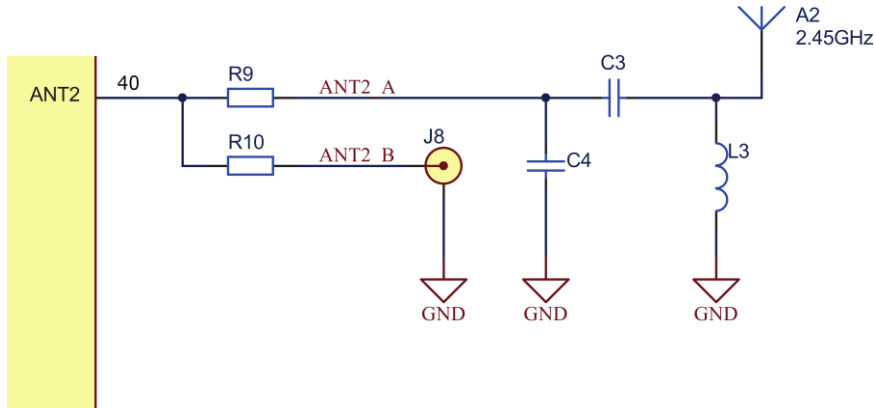

Figure 6: Reference schematic for antenna pin 2

### 5.1 Internal antenna

The reference design with internal antenna uses the SMD Johanson Technology type 2450AT45A100 antenna that is connected to the module RF-port via a coplanar micro-strip transmission line.

#### 5.1.1 Bill of materials

Reference designator	Description	Manufacturer	P/N
A2	Antenna CHIP 2.4-2.5GHz	Johanson Technology	2450AT45A100
C3	CAP, CER, 2.2pF, +/-0.1pF, COG, 50V, SMD 0402	Johanson Technology	500R07S2R2BV4
C4	CAP, CER, 1.8pF, +/-0.1pF, COG, 50V, SMD 0402	Johanson Technology	500R07S1R8BV4
L3	IND, Multilayer Ceramic, 3.9nH, +/-0.3nH, 300mA, SMD 0402	Johanson Technology	L-07C3N9SV6T
R9	0 $\Omega$ resistor, 0402	Generic	-
R10	Do not Assembly	-	-
J8	Do Not Assembly	-	-

#### 5.1.2 Antenna characteristics

Parameter	Low band	Unit
Frequency Range	2.4 – 2.5	GHz
Peak Gain	2.2	dBi
VSWR	< 2:1	-
Polarisation	Linear	-
Radiation pattern	Omnidirectional	-
Temperature range	-40 to +125	$^{\circ}$ C
Impedance	50	$\Omega$
Dimension (L x W x H)	9.5 x 2.0 x 1.2	mm



## 5.2 External antenna

The reference design with external antenna uses the micro coaxial connector that is connected to the external antenna via a 50  $\Omega$  pigtail. See section 6 for a list of available external antennas.

### 5.2.1 Bill of materials

Reference designator	Description	Manufacturer	P/N
A2	Do not Assembly	-	-
C3	Do Not Assembly	-	-
C4	Do not Assembly	-	-
L3	Do not Assembly	-	-
R9	Do Not Assembly	-	-
R10	0 $\Omega$ resistor, 0402	Generic	-
J8	Coaxial Connector, 0 – 6 GHz, SMD	Hirose	U.FL-R-SMT-1(10)

## 6 Approved external antenna list

For Bluetooth operation on EMMY-W163, the module has been tested and approved for use with antennas listed in Table 4.

Model name	Manufacturer and description	Gain [dBi] (peak)
ANT-2.4-CW-RCT-RP	Linx, Single-band dipole antenna	2.2 @ 2.4GHz band N/A @ 5GHz band
ANT-2.4-CW-RH	Linx, Single-band monopole antenna	-0.9
GW.26.0151	Taoglas, Single-band dipole antenna	0.0

**Table 4: Approved antennas list, single-band operation**

For Bluetooth and Wi-Fi operations in the 2.4 GHz band and Wi-Fi operation in the 5 GHz band, the module has been tested and approved for use with antennas listed in Table 5.

Model name	Manufacturer and description	Gain [dBi] (peak)
ANT-DB1-RAF-RPS	Linx, Dual-band dipole antenna	2.5 @ 2.4GHz band 4.6 @ 5GHz band
GW.40.2153	Taoglas, Dual-band dipole antenna	3.74 @ 2.4GHz band 2.5 @ 5GHz band
GW.59.3153	Taoglas, Dual-band dipole antenna	2.37 @ 2.4GHz band 2.93 @ 5GHz band
RFDPA8709005BLB8G1	Walsin, Dual-band dipole antenna	2 @ 2.4GHz band 3 @ 5GHz band
88395	Delock, Dual-band dipole antenna	1.5 @ 2.4GHz band 2.1 @ 5GHz band

**Table 5: Approved antennas list, dual-band operation**

## 7 NFC reference design

This section describes the available design for the NFC coil antenna of the EMMY-W1 modules.

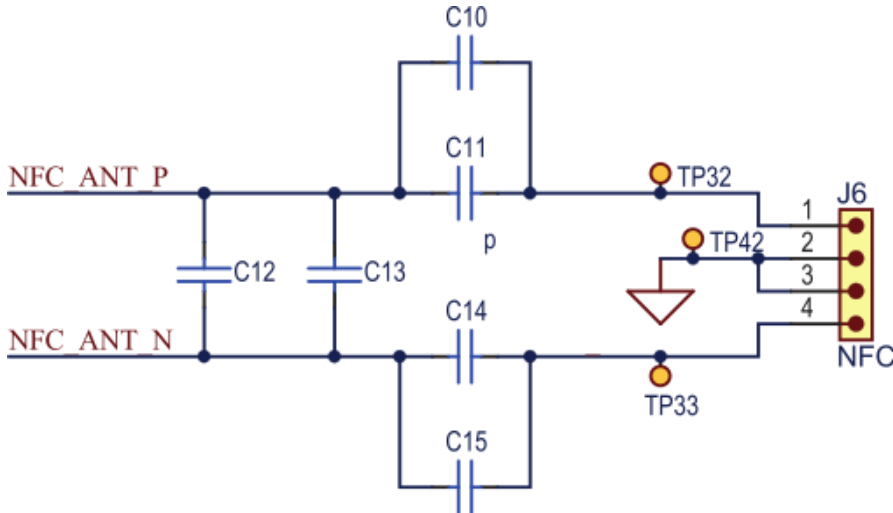

Figure 7: Reference schematic for NFC coil antenna

### 7.1 Internal antenna

The reference design uses a NFC coil antenna designed by u-blox.

#### 7.1.1 Bill of materials

Reference designator	Description	Manufacturer	P/N
J6	Pin Header, Pitch 2.54mm, 1x4 Way, Through Hole	Samtec	TSW-104-07-G-S
C10	Do Not Place	-	-
C11	CAP, CER, 220pF, 5%, NP0, 50V, SMD 0402	Murata	GRM1555C1H221JA01
C12	CAP, CER, 820pF, 5%, NP0, 50V, SMD 0402	Murata	GRM1555C1H821JA01
C13	Do Not Place	-	-
C14	CAP, CER, 820pF, 5%, NP0, 50V, SMD 0402	Murata	GRM1555C1H821JA01
C15	Do Not Place	-	-

#### 7.1.2 NFC coil characteristics

Parameter	Low band	Unit
Frequency Range	13.56	MHz
Number of turns	4	-
Trace width	0.4	mm
Trace spacing (edge to edge)	0.4	mm
Dimensions (L x W)	30 x 30	mm

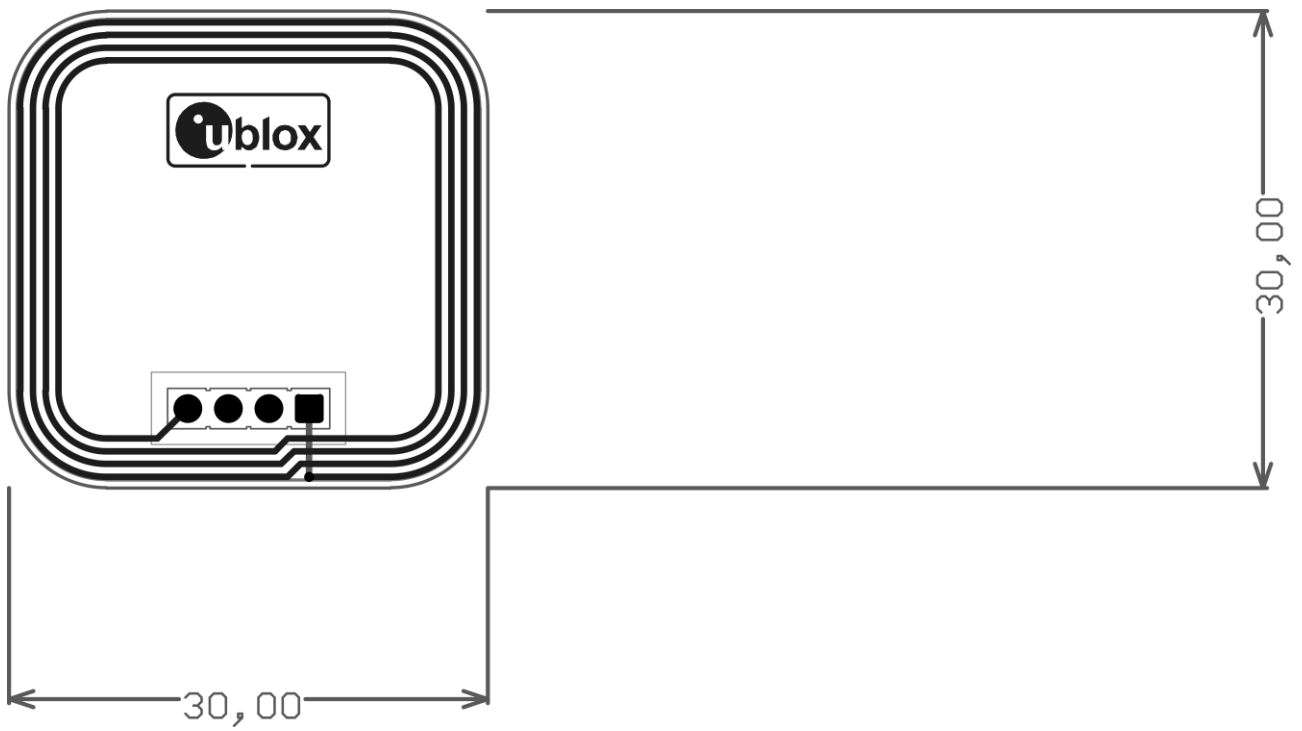

Figure 8: EMMY-W1 reference coil antenna, mechanical dimensions