

AT1608 Series

Multilayer Chip Antenna

Features

- ❖ Monolithic SMD with small, low-profile and light-weight type.
- ❖ Wide bandwidth
- ❖ RoHS compliant

Applications

- ❖ 2400~2500MHz ISM Band Systems

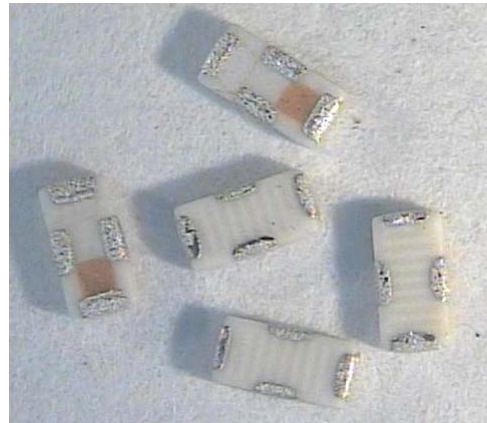

Specifications

Part Number	Frequency Range (MHz)	Peak Gain (dBi typ.)	Average Gain (dBi typ.)	VSWR	Impedance
AT1608-A2R4NAA_	2400~2480	0.5 (XZ-total)	-2.0 (XZ-total)	3 max.	50 Ω

(*Electrical specification is defined by the measurement of Scenario#1)

Q'ty/Reel (pcs) : 4,000 pcs
 Operating Temperature Range : -40 ~ +85 °C
 Storage Temperature Range : -40 ~ +85 °C
 Storage Period : 12 months max.
 Power Capacity : 2W max.

Part Number

AT 1608 - A 2R4 NAA □ □
 ① ② ③ ④ ⑤ ⑥ ⑦

① Type	AT : Antenna	② Dimensions (L x W)	1.6x 0.8 mm
③ Material Code	A	④ Frequency Range	2R4=2400MHz
⑤ Specification Code	NAA	⑥ Packaging	T: Tape & Reel B: Bulk
⑦ Soldering	/LF=lead-free		

Terminal Configuration

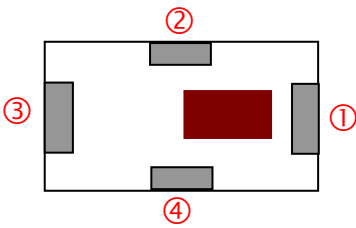

Scenario#1: Antenna on the edge side of PCBA			
No.	Terminal Name	No.	Terminal Name
①	Feeding Point	③	NC
②	GND	④	GND

Scenario#2: Antenna on the corner of PCBA			
No.	Terminal Name	No.	Terminal Name
①	Feeding Point	③	NC
②	NC	④	NC

Dimensions and Recommended PC Board Pattern

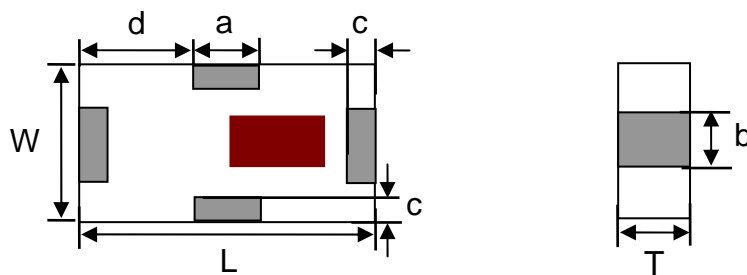

Unit : mm

Mark	L	W	T	a	b	c	d
Dimensions	1.6 ±	0.8 ±	0.4 ±	0.5 ±	0.5 ±	0.2 ±	0.55 ±
	0.1	0.1	0.1	0.1	0.1	0.05	0.1

Typical Electrical Characteristics for Scenario#1 (T=25°C)

❖ Test Board-Scenario#1

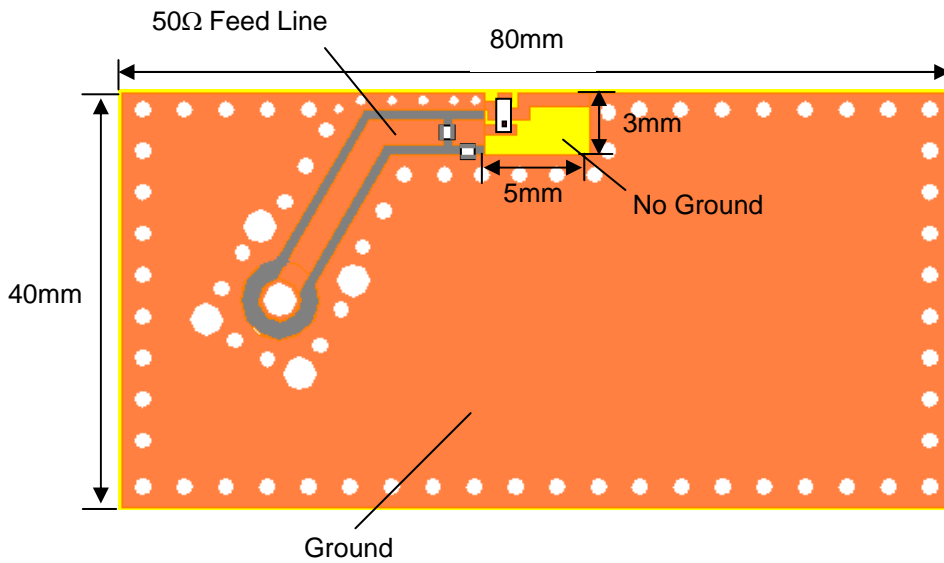

❖ Antenna Footprint With matching- Scenario#1 (Unit in mm)

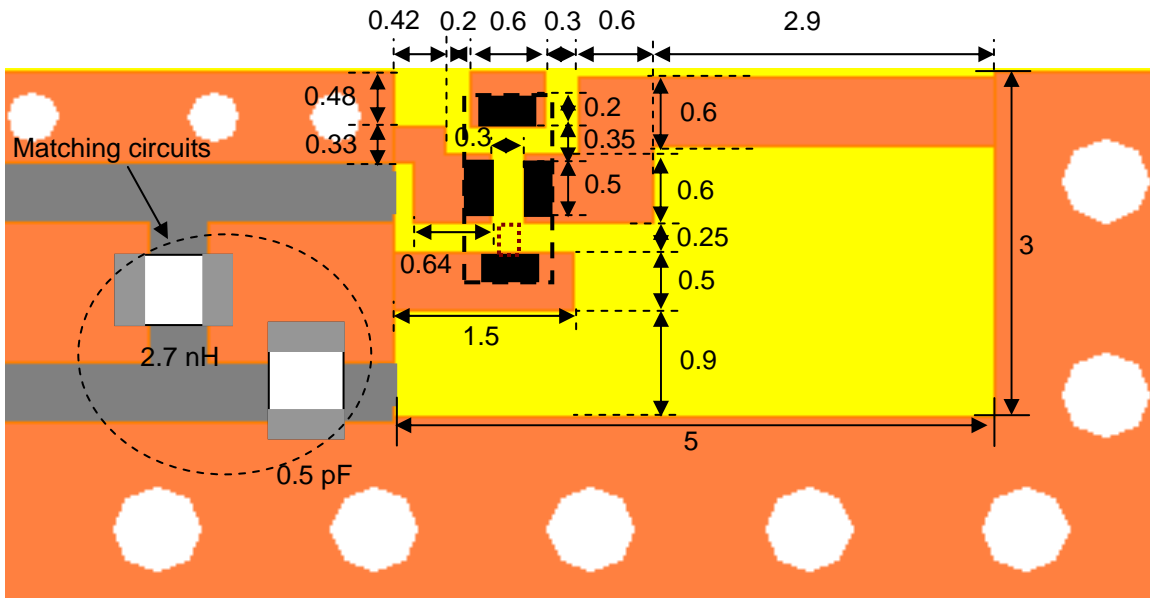

(Matching circuit and component values will be different, depending on PCB layout)

*Line width should be designed to match 50Ω characteristic impedance, depending on PCB material and thickness.

❖Return Loss (with matching)- Scenario#1

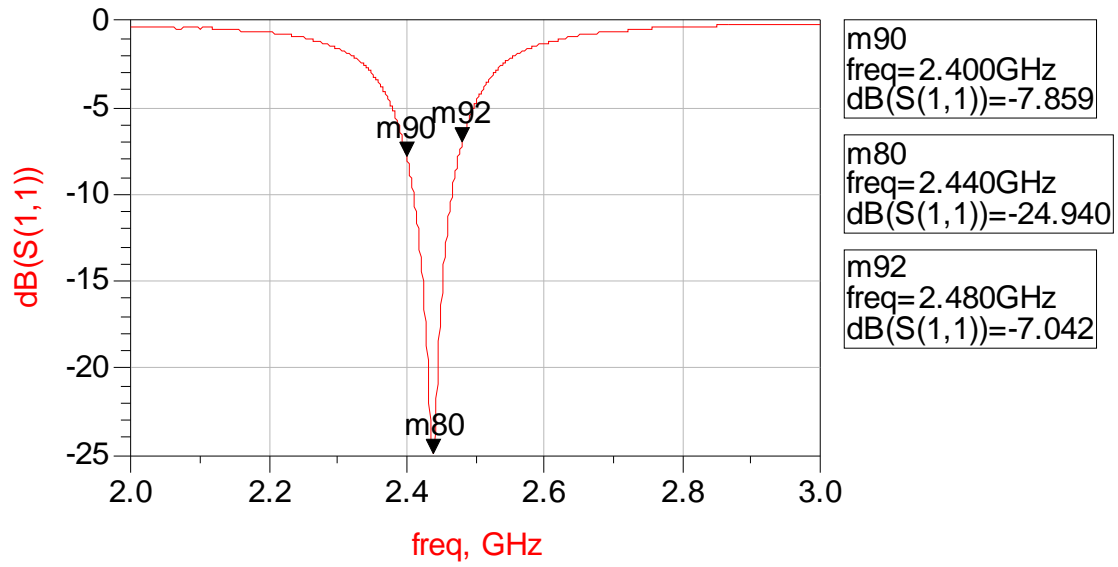

❖ Radiation Patterns- Scenario#1 (Antenna Efficiency: 50 %)

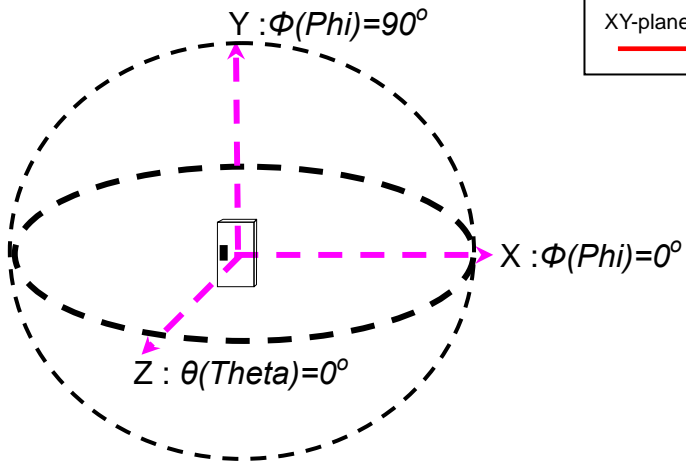

XY-plane @2440MHz
— Total

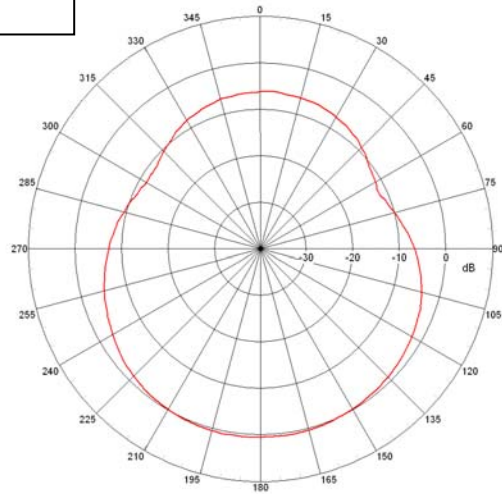

XZ-plane @2440MHz
— Total

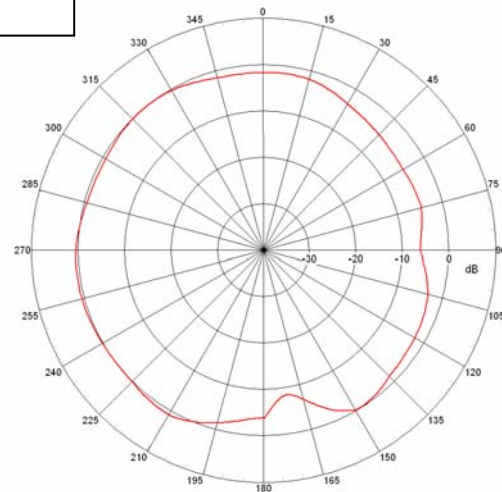

YZ-plane @2440MHz
— Total

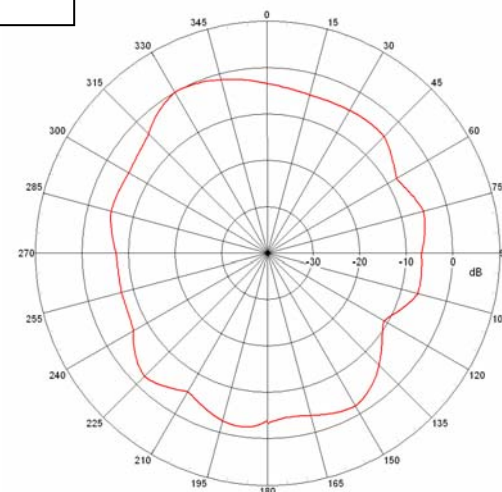

Typical Electrical Characteristics for Scenario#2 (T=25°C)

❖ Test Board- Scenario#2

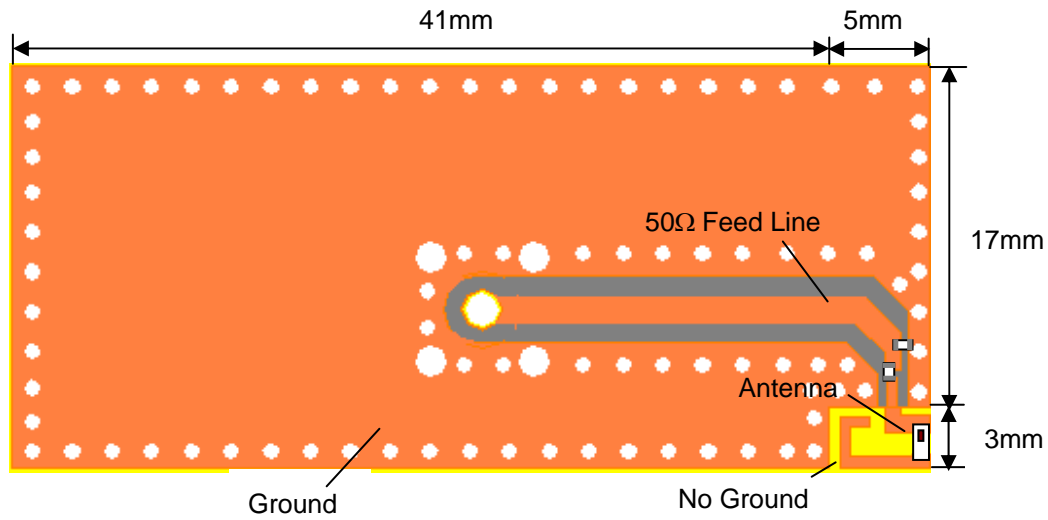

❖ Antenna Footprint With matching- Scenario#2

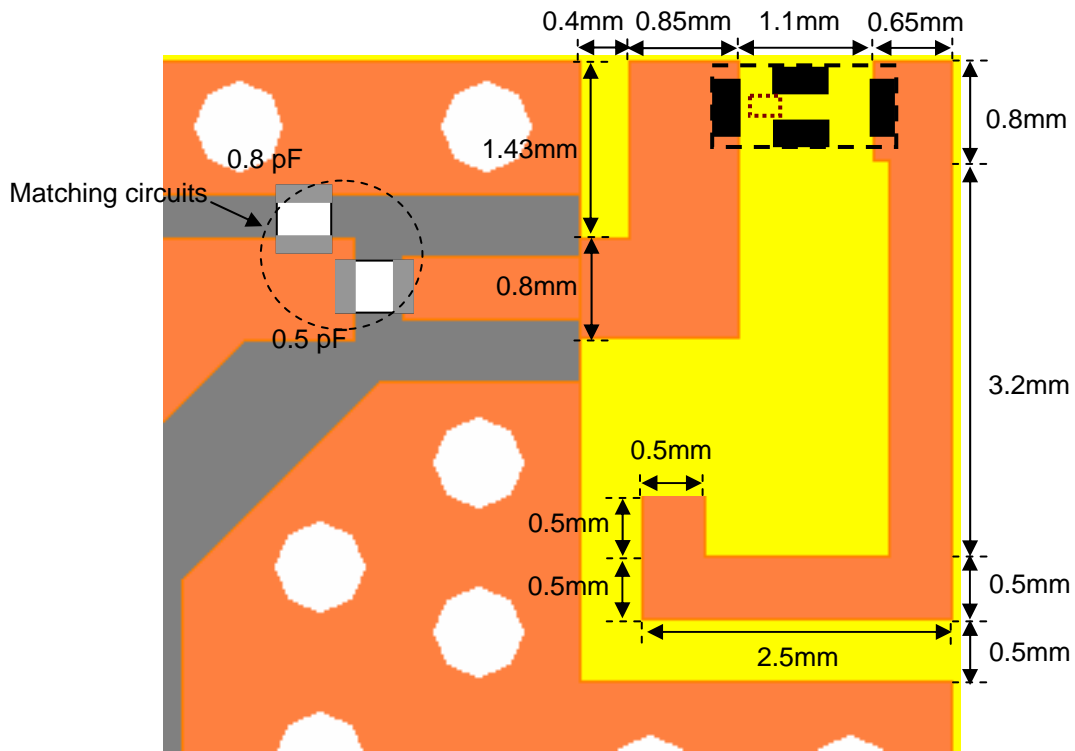

(Matching circuit and component values will be different, depending on PCB layout)

*Line width should be designed to match 50Ω characteristic impedance, depending on PCB material and thickness.

❖ Return Loss (with matching)- Scenario#2

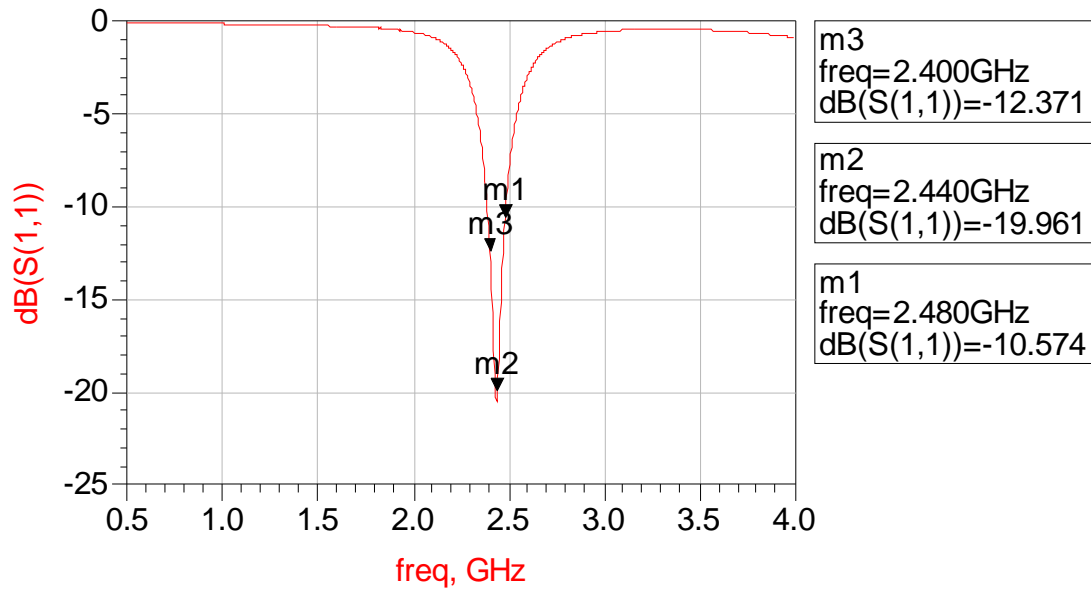

❖ Radiation Patterns- Scenario#2 (Antenna Efficiency: 50 %)

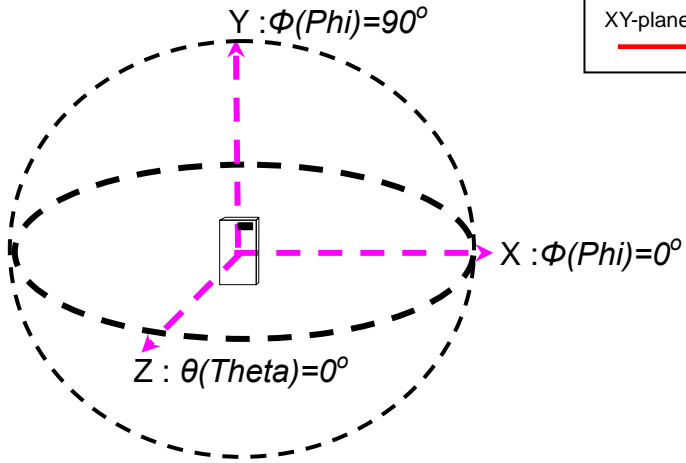

XY-plane @2440MHz
— Total

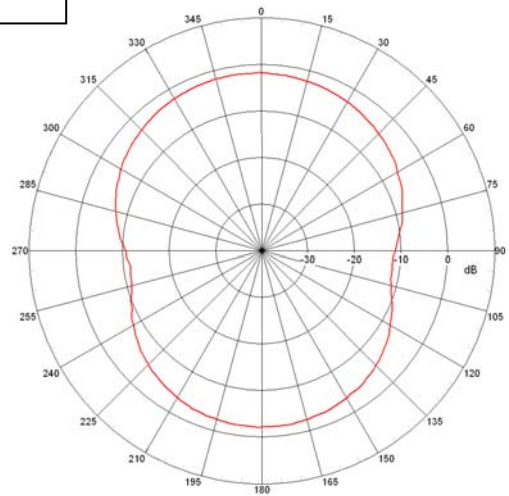

XZ-plane @2440MHz
— Total

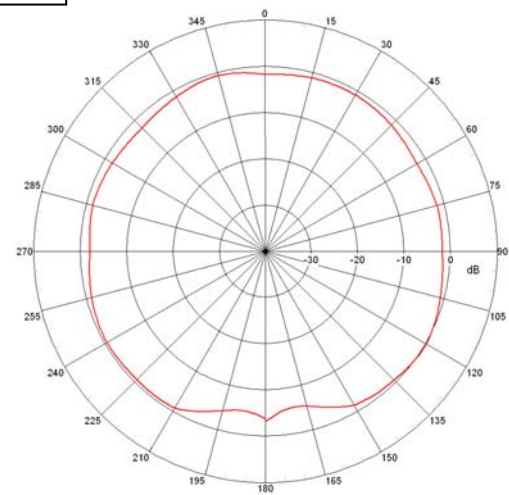

YZ-plane @2440MHz
— Total

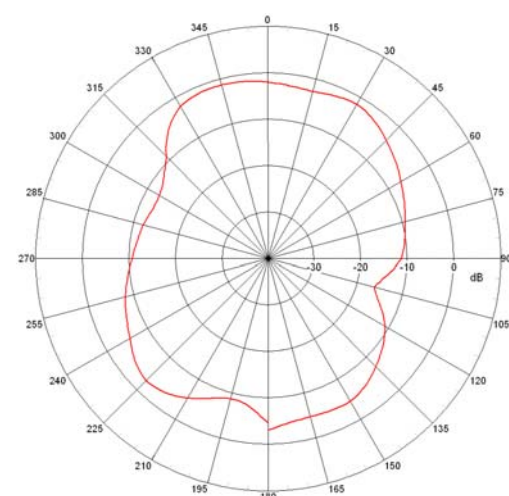

Taping Specifications

❖Tape & Reel Dimensions (Unit: mm) vs. Quantity (pcs)

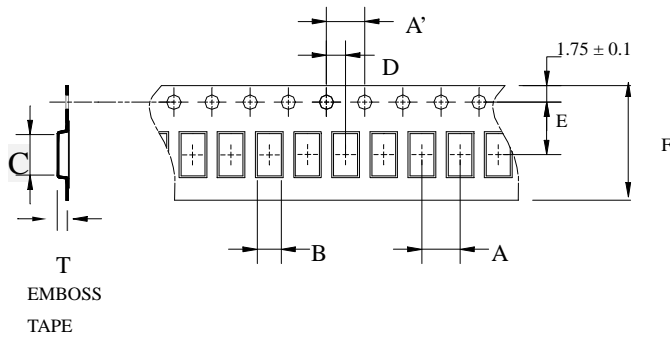

Type	A	A'	B	C	D	E	F	T	Quantity/per reel	Tape material
AT1608	4.0±	4.0±	0.95±	1.80±	2.0±	3.5±	8.0±	0.60±	4,000pcs	Paper
	0.1	0.1	0.1	0.1	0.1	0.1	0.1	0.03		

❖Reel Dimensions (Unit: mm)

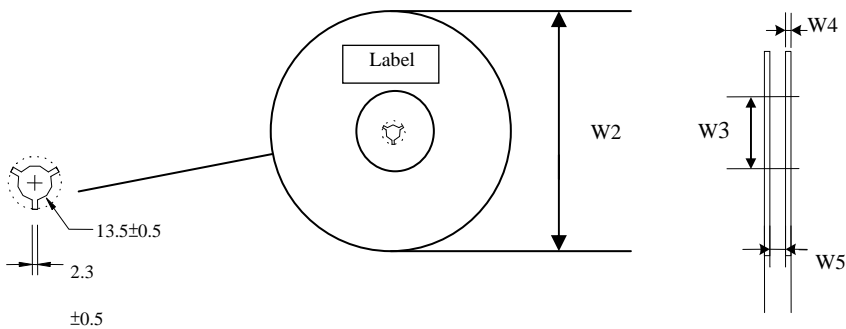

Label: Customer's Name,
 ACX P/N, Q'ty, Date,
 ACX Corp.

Type	W2	W3	W4	W5
AT1608	178±1	60±1	1.4±0.2	9.0±0.3

❖Leader and Trailer Tape

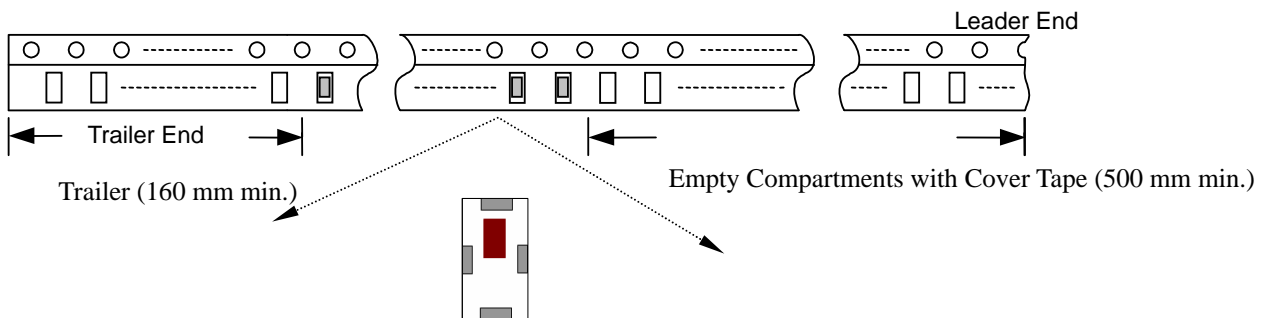

❖ **Peel-off Force**

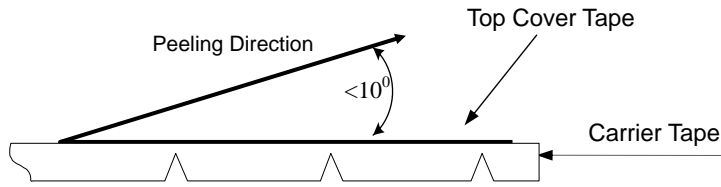

Peel-off force should be in the range of 0.1 – 0.6 N at a peel-off speed of 300 ± 10 mm/min .

❖ **Storage Conditions**

- (1) Temperature: 5 ~35°C , relative humidity (RH): 45~75%.
- (2) Non-corrosive environment

Notes

❖ The contents of this data sheet are subject to change without notice. Please confirm the specifications and delivery conditions when placing your order.

Mechanical & Environmental Characteristics

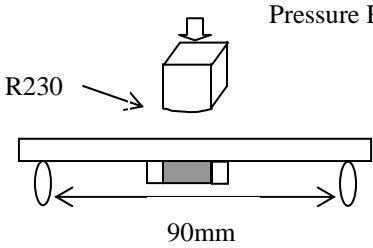
Item	Requirements	Procedure
Solderability	<ol style="list-style-type: none"> No apparent damage More than 95% of the terminal electrode shall be covered with new solder 	<ol style="list-style-type: none"> Preheat: $120 \pm 5^{\circ}\text{C}$ Solder: $245 \pm 5^{\circ}\text{C}$ for 5 ± 1 sec
Soldering strength (Termination Adhesion)	<ol style="list-style-type: none"> 1kg minimum 	<ol style="list-style-type: none"> Solder specimen onto test jig. Apply push force at 0.5mm/s until electrode pads are peeled off or ceramic are broken. Pushing force is applied to longitude direction.
Deflection (Substrate Bending)	<ol style="list-style-type: none"> No apparent damage 	<ol style="list-style-type: none"> Solder specimen onto test jig (FR4, 0.8mm) using the recommend soldering profile. Apply a bending force of 2mm deflection. 
Heat/Humidity Resistance	<ol style="list-style-type: none"> No apparent damage Fulfill the electrical specification after test 	<ol style="list-style-type: none"> Temperature: $85 \pm 2^{\circ}\text{C}$ Humidity: 90% ~ 95% RH Duration: 1000 ± 48hrs Recovery: 1-2hrs
Thermal shock (Temperature Cycle)	<ol style="list-style-type: none"> No apparent damage Fulfill the electrical specification after test 	<ol style="list-style-type: none"> One cycle/step 1 : $125 \pm 5^{\circ}\text{C}$ for 30 min step 2 : $-40 \pm 5^{\circ}\text{C}$ for 30 min No of cycles : 100 Recovery: 1-2 hrs
Low Temperature Resistance	<ol style="list-style-type: none"> No apparent damage Fulfill the electrical specification after test 	<ol style="list-style-type: none"> Temperature: $-40^{\circ} \pm 5^{\circ}\text{C}$ Duration: 500 ± 24hrs Recovery: 1-2hrs

Soldering Conditions

❖ Typical Soldering Profile for Lead-free Process

Reflow Soldering :

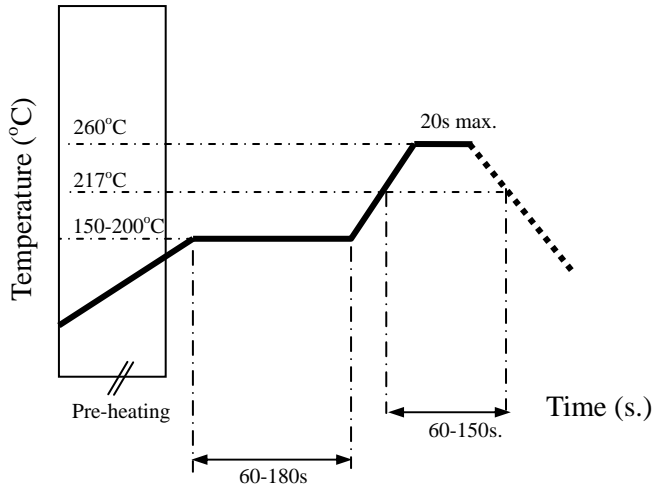

Notes

❖ The contents of this data sheet are subject to change without notice. Please confirm the specifications and delivery conditions when placing your order.

Advanced Ceramic X Corp.

16 Tzu Chiang Road, Hsinchu Industrial District Hsinchu Hsien 303, Taiwan

TEL:886-3-5987008 FAX:886-3-5987001

E-mail: acx@acxc.com.tw

<http://www.acxc.com.tw>