

FCC Test Report (PART 27)

Report No.: RF181120C09D

FCC ID: XPY2AGQN4NNN

Test Model: SARA-R410M

Received Date: Mar. 29, 2019

Test Date: Aug. 31 to Sep. 02, 2019

Issued Date: Sep. 20, 2019

Applicant: u-blox-AG

Address: Zuercherstrasse 68 8800 Thalwil, Switzerland

Issued By: Bureau Veritas Consumer Products Services (H.K.) Ltd., Taoyuan Branch
Hsin Chu Laboratory

Lab Address: E-2, No.1, Li Hsin 1st Road, Hsinchu Science Park, Hsinchu City 300,
Taiwan R.O.C.

Test Location: E-2, No.1, Li Hsin 1st Road, Hsinchu Science Park, Hsinchu City 300,
Taiwan R.O.C.

**FCC Registration /
Designation Number:** 723255 / TW2022



This report is for your exclusive use. Any copying or replication of this report to or for any other person or entity, or use of our name or trademark, is permitted only with our prior written permission. This report sets forth our findings solely with respect to the test samples identified herein. The results set forth in this report are not indicative or representative of the quality or characteristics of the lot from which a test sample was taken or any similar or identical product unless specifically and expressly noted. Our report includes all of the tests requested by you and the results thereof based upon the information that you provided to us. You have 60 days from date of issuance of this report to notify us of any material error or omission caused by our negligence, provided, however, that such notice shall be in writing and shall specifically address the issue you wish to raise. A failure to raise such issue within the prescribed time shall constitute your unqualified acceptance of the completeness of this report, the tests conducted and the correctness of the report contents. Unless specific mention, the uncertainty of measurement has been explicitly taken into account to declare the compliance or non-compliance to the specification. The report must not be used by the client to claim product certification, approval, or endorsement by TAF or any government agencies.

Table of Contents

Release Control Record	4
1 Certificate of Conformity	5
2 Summary of Test Results	6
2.1 Measurement Uncertainty	6
2.2 Test Site and Instruments	7
3 General Information	9
3.1 General Description of EUT	9
3.2 Configuration of System under Test	11
3.2.1 Description of Support Units	12
3.3 Test Mode Applicability and Tested Channel Detail	13
3.4 EUT Operating Conditions	18
3.5 General Description of Applied Standards	18
4 Test Types and Results	19
4.1 Output Power Measurement	19
4.1.1 Limits of Output Power Measurement	19
4.1.2 Test Procedures	19
4.1.3 Test Setup	20
4.1.4 Test Results	21
4.2 Modulation characteristics Measurement	35
4.2.1 Limits of Modulation characteristics	35
4.2.2 Test Procedure	35
4.2.3 Test Setup	35
4.2.4 Test Results	36
4.3 Frequency Stability Measurement	37
4.3.1 Limits of Frequency Stability Measurement	37
4.3.2 Test Procedure	37
4.3.3 Test Setup	37
4.3.4 Test Results	38
4.4 Emission Bandwidth Measurement	40
4.4.1 Limits of Emission Bandwidth Measurement	40
4.4.2 Test Procedure	40
4.4.3 Test Setup	40
4.4.4 Test Results (-26dB Bandwidth)	41
4.4.5 Test Results (Occupied Bandwidth)	44
4.5 Channel Edge Measurement	47
4.5.1 Limits of Channel Edge Measurement	47
4.5.2 Test Setup	47
4.5.3 Test Procedures	47
4.5.4 Test Results	48
4.6 Peak to Average Ratio	58
4.5.1 Limits of Peak to Average Ratio Measurement	58
4.5.2 Test Setup	58
4.5.3 Test Procedures	58
4.5.4 Test Results	59
4.7 Conducted Spurious Emissions	62
4.7.1 Limits of Conducted Spurious Emissions Measurement	62
4.7.2 Test Setup	62
4.7.3 Test Procedure	62
4.7.5 Test Results	63
4.8 Radiated Emission Measurement	85
4.8.1 Limits of Radiated Emission Measurement	85
4.8.2 Test Procedure	86
4.8.3 Deviation from Test Standard	86

4.8.4 Test Setup.....	87
4.8.5 Test Results	88
5 Pictures of Test Arrangements.....	148
Appendix – Information of the Testing Laboratories	149

Release Control Record

Issue No.	Description	Date Issued
RF181120C09D	Original release.	Sep. 20, 2019

1 Certificate of Conformity

Product: LTE CAT-M1 modem

Brand: u-blox-AG

Test Model: SARA-R410M

Sample Status: ENGINEERING SAMPLE

Applicant: u-blox-AG

Test Date: Aug. 31 to Sep. 02, 2019

Standards: FCC Part 27, Subpart H / L

The above equipment has been tested by **Bureau Veritas Consumer Products Services (H.K.) Ltd., Taoyuan Branch**, and found compliance with the requirement of the above standards. The test record, data evaluation & Equipment Under Test (EUT) configurations represented herein are true and accurate accounts of the measurements of the sample's EMC characteristics under the conditions specified in this report.

Prepared by :  , **Date:** Sep. 20, 2019
Claire Kuan / Specialist

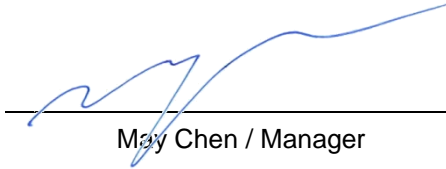
Approved by :  , **Date:** Sep. 20, 2019
May Chen / Manager

2 Summary of Test Results

Applied Standard: FCC Part 27 & Part 2			
FCC Clause	Test Item	Result	Remarks
2.1046 27.50	Radiated Power	PASS	Meet the requirement of limit.
2.1047	Modulation characteristics	PASS	Meet the requirement
2.1055 27.54	Frequency Stability Stay with the authorized bands of operation	PASS	Meet the requirement of limit.
2.1049 27.53	Occupied Bandwidth	PASS	Meet the requirement of limit.
27.53	Band Edge Measurements	PASS	Meet the requirement of limit.
27.50(d)(5)	Peak To Average Ratio	PASS	Meet the requirement of limit.
2.1051 27.53	Conducted Spurious Emissions	PASS	Meet the requirement of limit.
2.1053 27.53	Radiated Spurious Emissions	PASS	Meet the requirement of limit. Minimum passing margin is -23.75dB at 2122.5MHz.

NOTE:

- Determining compliance based on the results of the compliance measurement, not taking into account measurement instrumentation uncertainty.
- This report is prepared for FCC Class II permissive change.

2.1 Measurement Uncertainty

Where relevant, the following measurement uncertainty levels have been estimated for tests performed on the EUT as specified in CISPR 16-4-2:

Measurement	Frequency	Expanded Uncertainty (k=2) (±)
Radiated Emissions up to 1 GHz	9kHz ~ 1GHz	3.0 dB
	30MHz ~ 1GHz	5.1 dB
Radiated Emissions above 1 GHz	1GHz ~ 6GHz	5.1 dB
	6GHz ~ 18GHz	5.0 dB
	18GHz ~ 40GHz	5.2 dB

2.2 Test Site and Instruments

For radiated spurious emissions test:

DESCRIPTION & MANUFACTURER	MODEL NO.	SERIAL NO.	CALIBRATED DATE	CALIBRATED UNTIL
Test Receiver Agilent	N9038A	MY50010156	July 17, 2019	July 16, 2020
Pre-Amplifier EMCI	EMC001340	980142	May 30, 2019	May 29, 2020
Loop Antenna Electro-Metrics	EM-6879	264	Jan. 22, 2019	Jan. 21, 2020
RF Cable	NA	LOOPCAB-001	Jan. 14, 2019	Jan. 13, 2020
RF Cable	NA	LOOPCAB-002	Jan. 14, 2019	Jan. 13, 2020
Pre-Amplifier Mini-Circuits	ZFL-1000VH2B	AMP-ZFL-05	Apr. 30, 2019	Apr. 29, 2020
Trilog Broadband Antenna SCHWARZBECK	VULB 9168	9168-361	Nov. 22, 2018	Nov. 21, 2019
RF Cable	8D	966-3-1	Mar. 18, 2019	Mar. 17, 2020
RF Cable	8D	966-3-2	Mar. 18, 2019	Mar. 17, 2020
RF Cable	8D	966-3-3	Mar. 18, 2019	Mar. 17, 2020
Fixed attenuator Mini-Circuits	UNAT-5+	PAD-3m-3-01	Sep. 27, 2018	Sep. 26, 2019
Horn_Antenna SCHWARZBECK	BBHA9120-D	9120D-406	Nov. 25, 2018	Nov. 24, 2019
Pre-Amplifier EMCI	EMC12630SE	980384	Jan. 28, 2019	Jan. 27, 2020
RF Cable	EMC104-SM-SM-1200	160922	Jan. 28, 2019	Jan. 27, 2020
RF Cable	EMC104-SM-SM-2000	180601	June 10, 2019	June 09, 2020
RF Cable	EMC104-SM-SM-6000	180602	June 10, 2019	June 09, 2020
Spectrum Analyzer Keysight	N9030A	MY54490679	July 17, 2019	July 16, 2020
Pre-Amplifier EMCI	EMC184045SE	980387	Jan. 28, 2019	Jan. 27, 2020
Horn_Antenna SCHWARZBECK	BBHA 9170	BBHA9170519	Nov. 25, 2018	Nov. 24, 2019
RF Cable	EMC102-KM-KM-1200	160924	Jan. 28, 2019	Jan. 27, 2020
RF Cable	EMC102-KM-KM-1200	160925	Jan. 28, 2019	Jan. 27, 2020
Software	ADT_Radiated_V8.7.08	NA	NA	NA
Antenna Tower & Turn Table Max-Full	MF-7802	MF780208406	NA	NA
Boresight Antenna Fixture	FBA-01	FBA-SIP01	NA	NA

Note:

1. The calibration interval of the above test instruments is 12 months and the calibrations are traceable to NML/ROC and NIST/USA.
2. The test was performed in 966 Chamber No. 3.
3. Loop antenna was used for all emissions below 30 MHz.
4. Tested Date: Aug. 31, 2019

For other test:

DESCRIPTION & MANUFACTURER	MODEL NO.	SERIAL NO.	CALIBRATED DATE	CALIBRATED UNTIL
Spectrum Analyzer R&S	FSV40	100964	June 04, 2019	June 03, 2020
Spectrum Analyzer Keysight	N9030A	MY54490570	June 19, 2019	June 18, 2020
Power meter Anritsu	ML2495A	1014008	May 13, 2019	May 12, 2020
Power sensor Anritsu	MA2411B	0917122	May 13, 2019	May 12, 2020
Fixed Attenuator Mini-Circuits	MDCS18N-10	MDCS18N-10-01	Apr. 15, 2019	Apr. 14, 2020
AC Power Source Extech Electronics	6205	1440452	NA	NA
DC Power Supply Topward	6603D	795558	NA	NA
Temperature & Humidity Chamber Giant Force	GTH-150-40-SP-AR	MAA0812-008	Jan. 09, 2019	Jan. 08, 2020
True RMS Clamp Meter FLUKE	325	31130711WS	May 21, 2019	May 20, 2020
ESG Vector signal generator Agilent	E4438C	MY45094468/005 506 602 UK6 UNJ	Nov. 19, 2018	Nov. 18, 2019
Mech Switch Absorptive Mini-Circuits	MSP4TA-18+	0140	Feb. 11, 2019	Feb. 10, 2020
FXD ATTEN Mini-Circuits	BW-S3W2+	MN71981	Feb. 11, 2019	Feb. 10, 2020
Software	ADT_RF Test Software V6.6.5.4	NA	NA	NA

- NOTE:**
1. The test was performed in Oven room 2.
 2. The calibration interval of the above test instruments is 12 months and the calibrations are traceable to NML/ROC and NIST/USA.
 3. Tested Date: Sep. 02, 2019

3 General Information

3.1 General Description of EUT

Product	LTE CAT-M1 modem	
Brand	u-blox-AG	
Test Model	SARA-R410M	
Status of EUT	ENGINEERING SAMPLE	
Power Supply Rating	DC 3.3V from host equipment	
Modulation Type	QPSK, 16QAM	
Operating Frequency	LTE Band 4	1710.7 ~ 1754.3 MHz
	LTE Band 12	699.7 ~ 715.3 MHz
Max. EIRP Power	LTE Band 4	QPSK: 24.99 dBm
	(Channel Bandwidth 1.4MHz)	16QAM: 24.01 dBm
	LTE Band 4	QPSK: 25.07 dBm
	(Channel Bandwidth 3MHz)	16QAM: 24.08 dBm
	LTE Band 4	QPSK: 25.23 dBm
	(Channel Bandwidth 5MHz)	16QAM: 24.21 dBm
	LTE Band 4	QPSK: 25.25 dBm
	(Channel Bandwidth 10MHz)	16QAM: 24.26 dBm
Max. ERP Power	LTE Band 4	QPSK: 25.33 dBm
	(Channel Bandwidth 15MHz)	16QAM: 25.16 dBm
	LTE Band 4	QPSK: 25.35 dBm
	(Channel Bandwidth 20MHz)	16QAM: 25.25 dBm
	LTE Band 12	QPSK: 21.83 dBm
	(Channel Bandwidth 1.4MHz)	16QAM: 21.82 dBm
	LTE Band 12	QPSK: 22.40 dBm
	(Channel Bandwidth 3MHz)	16QAM: 21.88 dBm
Max. ERP Power	LTE Band 12	QPSK: 22.42 dBm
	(Channel Bandwidth 5MHz)	16QAM: 22.00 dBm
	LTE Band 12	QPSK: 22.40 dBm
	(Channel Bandwidth 10MHz)	16QAM: 22.00 dBm

Emission Designator	LTE Band 4 (Channel Bandwidth 1.4MHz)	QPSK: 1M14G7D 16QAM: 1M12D7W	
	LTE Band 4 (Channel Bandwidth 3MHz)	QPSK: 1M20G7D 16QAM: 1M14D7W	
	LTE Band 4 (Channel Bandwidth 5MHz)	QPSK: 1M16G7D 16QAM: 1M18D7W	
	LTE Band 4 (Channel Bandwidth 10MHz)	QPSK: 1M16G7D 16QAM: 1M20D7W	
	LTE Band 4 (Channel Bandwidth 15MHz)	QPSK: 1M16G7D 16QAM: 1M20D7W	
	LTE Band 4 (Channel Bandwidth 20MHz)	QPSK: 1M17G7D 16QAM: 1M20D7W	
	LTE Band 12 (Channel Bandwidth 1.4MHz)	QPSK: 1M14G7D 16QAM: 1M12D7W	
	LTE Band 12 (Channel Bandwidth 3MHz)	QPSK: 1M20G7D 16QAM: 1M14D7W	
	LTE Band 12 (Channel Bandwidth 5MHz)	QPSK: 1M20G7D 16QAM: 1M18D7W	
	LTE Band 12 (Channel Bandwidth 10MHz)	QPSK: 1M14G7D 16QAM: 1M22D7W	
	Antenna Type	Refer to Note	
	Antenna Connector	Refer to Note	
Accessory Device	NA		
Data Cable Supplied	NA		

Note:

- This report is prepared for FCC Class II permissive change. The difference compared with the Report No.: RF181120C09 design is as the following information:
 - ◆ LTE Cat M1 test mode change for LTE Band 2,4,12 adding bandwidth measurements.
 - ◆ Antenna trace layout design changed and antenna changed.
- According to above conditions, all test items need to be performed. And all data were verified to meet the requirements.
- The antennas provided to the EUT, please refer to the following table:

Antenna No.	Brand	Model	Antenna Net Gain (dBi)	Frequency range	Antenna Type	Connector Type	Cable Length
LTE Antenna	AT&T	95XKAB15.G45	2.7	FDD 2: 1850 MHz to 1910 MHz	IFA	i-pex(MHF)	49.5mm
			3	FDD 4: 1710 MHz to 1755 MHz			
			2	FDD 12: 698 MHz to 716 MHz			

- The above EUT information is declared by manufacturer and for more detailed features description, please refer to the manufacturer's specifications or User's Manual.

3.2 Configuration of System under Test

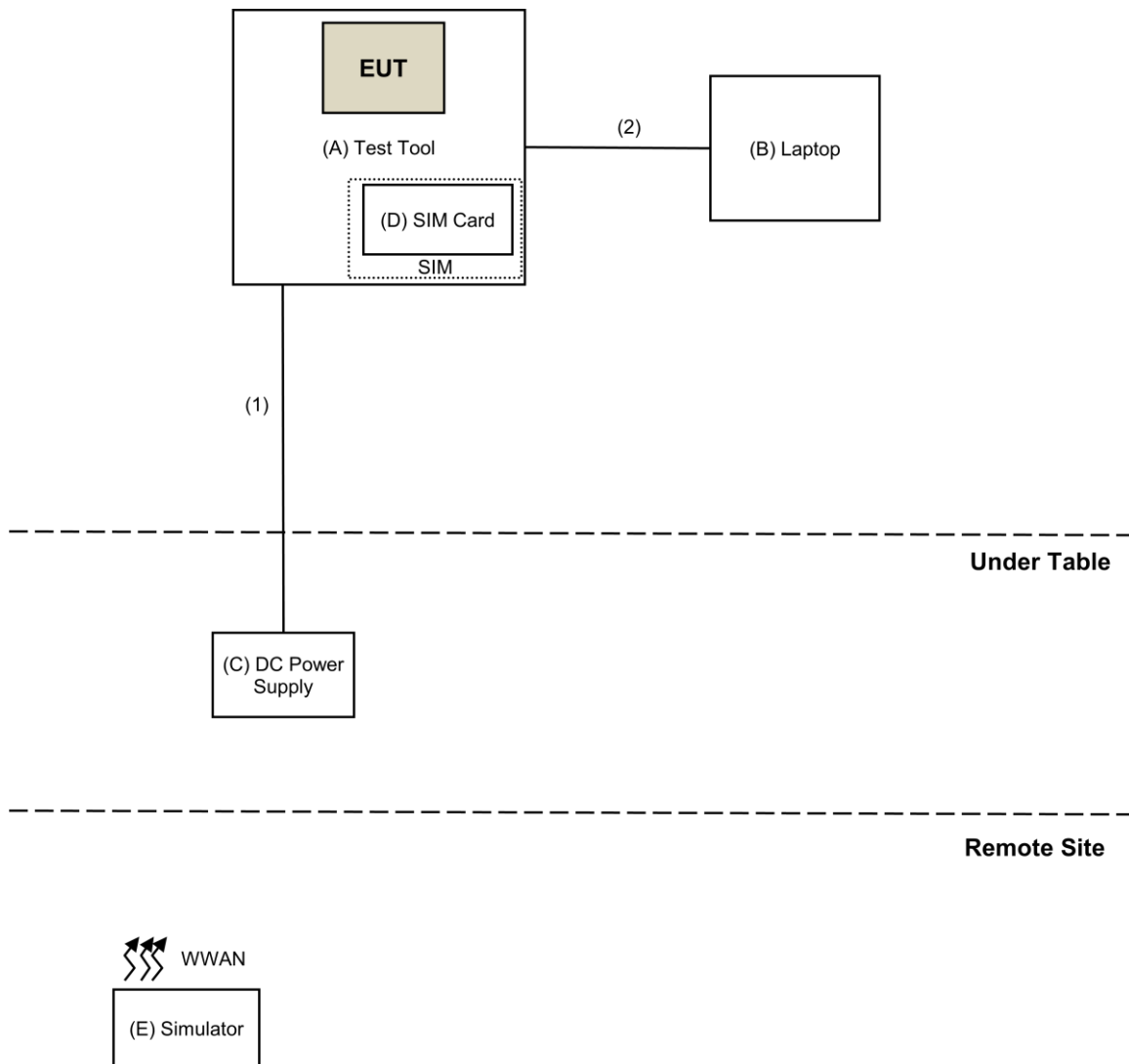

3.2.1 Description of Support Units

The EUT has been tested as an independent unit together with other necessary accessories or support units. The following support units or accessories were used to form a representative test configuration during the tests.

ID	Product	Brand	Model No.	Serial No.	FCC ID	Remarks
A.	Test Tool	NA	NA	NA	NA	Supplied by client
B.	Laptop	Lenovo	80WG	YD025N5Q	NA	Provided by Lab
C.	DC Power Supply	Topward	6603D	795551	NA	Provided by Lab
D.	SIM Card	R&S	CMW-Z04	NA	NA	Provided by Lab
E.	Simulator	Anritsu	MT8820C	6201127458	NA	Provided by Lab

Note:

1. All power cords of the above support units are non-shielded (1.8m).

ID	Descriptions	Qty.	Length (m)	Shielding (Yes/No)	Cores (Qty.)	Remarks
1.	DC Cable	1	1.8	No	0	Provided by Lab
2.	Console Cable	1	0.235	Yes	0	Supplied by client

3.3 Test Mode Applicability and Tested Channel Detail

In the original test report, pre-scan has been conducted to determine the worst-case mode from all possible combinations between available modulations, data rates, XYZ axis and antenna ports.

The worst case was found when positioned on Z-plane. Following channel(s) was (were) selected for the final test as listed below:

LTE Band 4

TEST ITEM	Available Channel	Tested Channel	Channel bandwidth	MODULATION	RB		
					SIZE	offset	Index
EIRP	19957 to 20393	19957, 20175, 20393	1.4MHz	QPSK/16QAM	1	0	0
	19965 to 20385	19965, 20175, 20385	3MHz	QPSK/16QAM	1	0	0
	19975 to 20375	19975, 20175, 20375	5MHz	QPSK/16QAM	1	0	0
	20000 to 20350	20000, 20175, 20350	10MHz	QPSK/16QAM	1	0	0
	20025 to 20325	20025, 20175, 20325	15MHz	QPSK/16QAM	1	0	0
	20050 to 20300	20050, 20175, 20300	20MHz	QPSK/16QAM	1	0	0
Frequency Stability	19957 to 20393	20175	1.4MHz	QPSK	1	0	0
	19965 to 20385	20175	3MHz	QPSK	1	0	0
	19975 to 20375	20175	5MHz	QPSK	1	0	0
	20000 to 20350	20175	10MHz	QPSK	1	0	0
	20025 to 20325	20175	15MHz	QPSK	1	0	0
	20050 to 20300	20175	20MHz	QPSK	1	0	0
Occupied Bandwidth	19957 to 20393	19957, 20175, 20393	1.4MHz	QPSK/16QAM	6	0	0
	19965 to 20385	19965, 20175, 20385	3MHz	QPSK/16QAM	6	0	0
	19975 to 20375	19975, 20175, 20375	5MHz	QPSK/16QAM	6	0	0
	20000 to 20350	20000, 20175, 20350	10MHz	QPSK/16QAM	6	0	0
	20025 to 20325	20025, 20175, 20325	15MHz	QPSK/16QAM	6	0	0
	20050 to 20300	20050, 20175, 20300	20MHz	QPSK/16QAM	6	0	0
Peak to Average Ratio	19957 to 20393	19957, 20175, 20393	1.4MHz	QPSK/16QAM	6	0	0
	19965 to 20385	19965, 20175, 20385	3MHz	QPSK/16QAM	6	0	0
	19975 to 20375	19975, 20175, 20375	5MHz	QPSK/16QAM	6	0	0
	20000 to 20350	20000, 20175, 20350	10MHz	QPSK/16QAM	6	0	0
	20025 to 20325	20025, 20175, 20325	15MHz	QPSK/16QAM	6	0	0
	20050 to 20300	20050, 20175, 20300	20MHz	QPSK/16QAM	6	0	0

TEST ITEM	Available Channel	Tested Channel	Channel bandwidth	MODULATION	RB		
					SIZE	offset	Index
Band Edge	19957 to 20393	19957	1.4MHz	QPSK	1	0	0
					6	0	0
		20393			1	5	0
					6	0	0
	19965 to 20385	19965	3MHz	QPSK	1	0	0
					6	0	0
		20385			1	5	1
					6	0	1
	19975 to 20375	19975	5MHz	QPSK	1	0	0
					6	0	0
		20375			1	5	3
					6	0	3
	20000 to 20350	20000	10MHz	QPSK	1	0	0
					6	0	0
		20350			1	5	7
					6	0	7
	20025 to 20325	20025	15MHz	QPSK	1	0	0
					6	0	0
		20325			1	5	11
					6	0	11
	20050 to 20300	20050	20MHz	QPSK	1	0	0
					6	0	0
		20300			1	5	11
					6	0	11
Conducted Emission	19957 to 20393	19957, 20175, 20393	1.4MHz	QPSK	1	0	0
	19965 to 20385	19965, 20175, 20385	3MHz	QPSK	1	0	0
	19975 to 20375	19975, 20175, 20375	5MHz	QPSK	1	0	0
	20000 to 20350	20000, 20175, 20350	10MHz	QPSK	1	0	0
	20025 to 20325	20025, 20175, 20325	15MHz	QPSK	1	0	0
	20050 to 20300	20050, 20175, 20300	20MHz	QPSK	1	0	0

TEST ITEM	Available Channel	Tested Channel	Channel bandwidth	MODULATION	RB		
					SIZE	offset	Index
Radiated Emission	19957 to 20393	19957, 20175, 20393	1.4MHz	QPSK	1	0	0
	19965 to 20385	19965, 20175, 20385	3MHz	QPSK	1	0	0
	19975 to 20375	19975, 20175, 20375	5MHz	QPSK	1	0	0
	20000 to 20350	20000, 20175, 20350	10MHz	QPSK	1	0	0
	20025 to 20325	20025, 20175, 20325	15MHz	QPSK	1	0	0
	20050 to 20300	20050, 20175, 20300	20MHz	QPSK	1	0	0
Modulation Characteristics	20050 to 20300	20175	20MHz	QPSK/16QAM	6	0	0

LTE Band 12

TEST ITEM	Available Channel	Tested Channel	Channel bandwidth	MODULATION	SIZE	offset	Index
EIRP	19957 to 20393	19957, 23095, 23173	1.4MHz	QPSK/16QAM	1	0	0
	19965 to 20385	19965, 23095, 23165	3MHz	QPSK/16QAM	1	0	0
	19975 to 20375	19975, 23095, 23155	5MHz	QPSK/16QAM	1	0	0
	20000 to 20350	20000, 23095, 23130	10MHz	QPSK/16QAM	1	0	0
Frequency Stability	19957 to 20393	23095	1.4MHz	QPSK	1	0	0
	19965 to 20385	23095	3MHz	QPSK	1	0	0
	19975 to 20375	23095	5MHz	QPSK	1	0	0
	20000 to 20350	23095	10MHz	QPSK	1	0	0
Occupied Bandwidth	19957 to 20393	19957, 23095, 23173	1.4MHz	QPSK/16QAM	6	0	0
	19965 to 20385	19965, 23095, 23165	3MHz	QPSK/16QAM	6	0	0
	19975 to 20375	19975, 23095, 23155	5MHz	QPSK/16QAM	6	0	0
	20000 to 20350	20000, 23095, 23130	10MHz	QPSK/16QAM	6	0	0
Peak to Average Ratio	19957 to 20393	19957, 23095, 23173	1.4MHz	QPSK/16QAM	6	0	0
	19965 to 20385	19965, 23095, 23165	3MHz	QPSK/16QAM	6	0	0
	19975 to 20375	19975, 23095, 23155	5MHz	QPSK/16QAM	6	0	0
	20000 to 20350	20000, 23095, 23130	10MHz	QPSK/16QAM	6	0	0
Band Edge	19957 to 20393	19957	1.4MHz	QPSK	1	0	0
		23173			6	0	0
					1	5	0
		6			0	0	
	19965 to 20385	19965	3MHz	QPSK	1	0	0
		23165			6	0	0
					1	5	1
		6			0	1	
	19975 to 20375	19975	5MHz	QPSK	1	0	0
		23155			6	0	0
					1	5	3
		6			0	3	
	20000 to 20350	20000	10MHz	QPSK	1	0	0
		23130			6	0	0
					1	5	7
		6			0	7	

TEST ITEM	Available Channel	Tested Channel	Channel bandwidth	MODULATION	RB		
					SIZE	offset	Index
Conducted Emission	19957 to 20393	19957, 23095, 23173	1.4MHz	QPSK	1	0	0
	19965 to 20385	19965, 23095, 23165	3MHz	QPSK	1	0	0
	19975 to 20375	19975, 23095, 23155	5MHz	QPSK	1	0	0
	20000 to 20350	20000, 23095, 23130	10MHz	QPSK	1	0	0
Radiated Emission	19957 to 20393	19957, 23095, 23173	1.4MHz	QPSK	1	0	0
	19965 to 20385	19965, 23095, 23165	3MHz	QPSK	1	0	0
	19975 to 20375	19975, 23095, 23155	5MHz	QPSK	1	0	0
	20000 to 20350	20000, 23095, 23130	10MHz	QPSK	1	0	0
Modulation Characteristics	20050 to 20300	23095	10MHz	QPSK/16QAM	6	0	0

NOTE:

All supported modulation types were evaluated. The Worst case of QPSK was selected. Therefore, the Frequency Stability, Band Edge, Condcudeted Emission and Radiated Emission were presented under QPSK mode only.

Test Condition:

Test Item	Environmental Conditions	Input Power (System)	Tested By
EIRP/ERP	25deg. C, 60%RH	120Vac, 60Hz	Jyunchun Lin
Frequency Stability	25deg. C, 60%RH	120Vac, 60Hz	Jyunchun Lin
Occupied Bandwidth	25deg. C, 60%RH	120Vac, 60Hz	Jyunchun Lin
Band Edge	25deg. C, 60%RH	120Vac, 60Hz	Jyunchun Lin
Peak to Average Ratio	25deg. C, 60%RH	120Vac, 60Hz	Jyunchun Lin
Condcudeted Emission	25deg. C, 60%RH	120Vac, 60Hz	Jyunchun Lin
Radiated Emission Below 1GHz	25deg. C, 66%RH	120Vac, 60Hz	Robert Cheng
Radiated Emission Above 1GHz	23deg. C, 70%RH	120Vac, 60Hz	Robert Cheng

3.4 EUT Operating Conditions

The communication simulator station system controlled a EUT to export maximum output power under transmission mode and specific channel frequency

3.5 General Description of Applied Standards

The EUT is a RF Product. According to the specifications of the manufacturer, it must comply with the requirements of the following standards:

FCC 47 CFR Part 2

FCC 47 CFR Part 27, Subpart H / L

KDB 971168 D01 Power Meas License Digital Systems v03r01

ANSI/TIA/EIA-603-E 2016

ANSI 63.26-2015

NOTE: All test items have been performed and recorded as per the above standards.

4 Test Types and Results

4.1 Output Power Measurement

4.1.1 Limits of Output Power Measurement

For section 27.50(d)(4): Fixed, mobile, and portable (hand-held) stations operating in the 1710-1755 MHz band and mobile and portable stations operating in the 1695-1710 MHz and 1755-1780 MHz bands are limited to 1 watt EIRP.

For section 27.50 (c)(10): Portable stations (hand-held devices) in the 600 MHz uplink band and the 698-746 MHz band, and fixed and mobile stations in the 600 MHz uplink band are limited to 3 watts ERP.

4.1.2 Test Procedures

Conducted Power Measurement:

The EUT was set up for the maximum power with LTE link data modulation and link up with simulator. Set the EUT to transmit under low, middle and high channel and difference RB size/ RB offset for difference bandwidth record the power level shown on power meter.

EIRP / ERP Measurement:

- a. $EIRP = \text{Conducted Output power level} + \text{Antenna gain}$.
- b. ERP power can be calculated from EIRP power by subtracting the gain of dipole, $ERP \text{ power} = EIPR \text{ power} - 2.15dBi$.
- c. $ERP = \text{Conducted Output power level} + \text{Antenna gain (dBi)} - \text{Isotropically Factor (2.15dB)}$

4.1.3 Test Setup

Conducted Power Measurement:

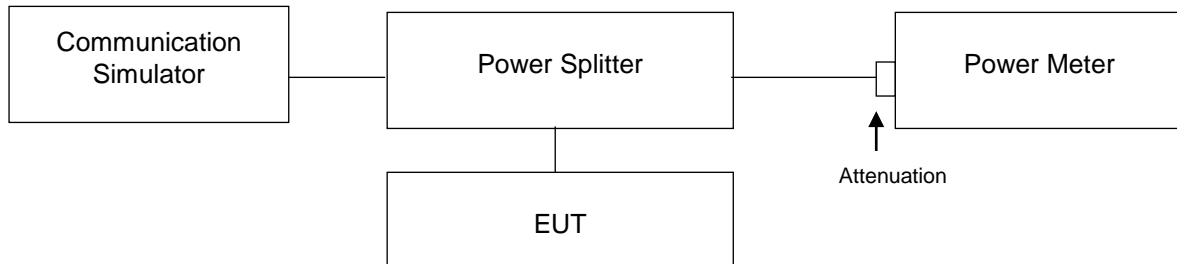

EIRP/ERP Power Measurement:

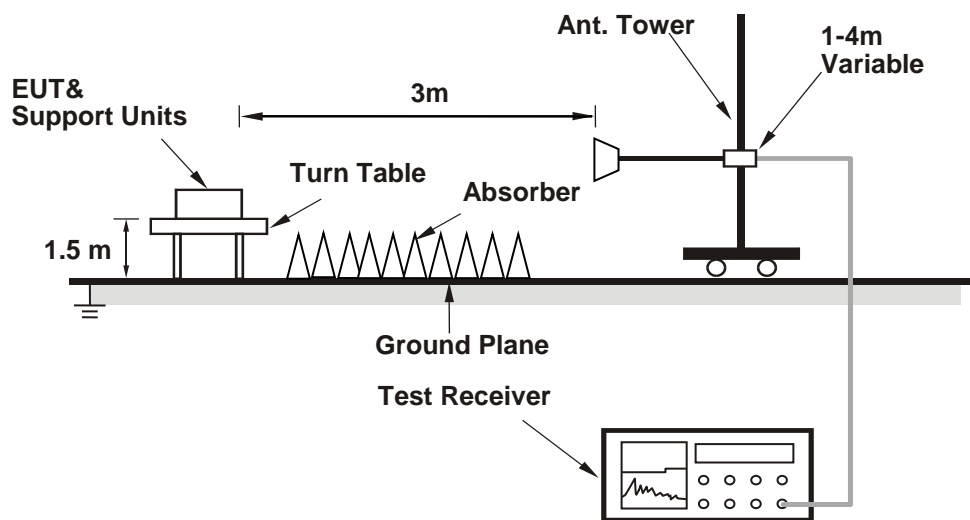

For the actual test configuration, please refer to the attached file (Test Setup Photo).

4.1.4 Test Results

CONDUCTED OUTPUT POWER (dBm)

LTE Band 4

Band / BW	RB Size	RB Offset	RB Index	QPSK			3GPP MPR (dB)
				Low Ch 19957	Mid Ch 20175	High Ch 20393	
				1710.7 MHz	1732.5 MHz	1754.3 MHz	
4 / 1.4M	1	0	0	21.86	21.95	21.99	0
	1	5	0	21.93	21.90	21.80	0
	3	3	0	21.03	20.80	21.04	1
	6	0	0	20.16	20.04	20.08	2

Band / BW	RB Size	RB Offset	RB Index	16QAM			3GPP MPR (dB)
				Low Ch 19957	Mid Ch 20175	High Ch 20393	
				1710.7 MHz	1732.5 MHz	1754.3 MHz	
4 / 1.4M	1	0	0	20.83	20.89	20.95	1
	1	5	0	21.01	20.94	20.88	1
	3	0	0	19.98	19.94	19.80	2
	5	0	0	19.96	19.95	19.82	2

Band / BW	RB Size	RB Offset	RB Index	QPSK			3GPP MPR (dB)
				Low Ch 19965	Mid Ch 20175	High Ch 20385	
				1711.5 MHz	1732.5 MHz	1753.5 MHz	
4 / 3M	1	0	0	22.06	21.95	21.96	0
	1	5	0	21.98	21.89	22.07	0
	1	0	1	22.04	21.85	21.93	0
	1	5	1	21.89	22.06	21.99	0
	3	3	0	21.11	21.07	20.99	1
	3	3	1	21.03	20.94	20.99	1
	6	0	0	20.19	20.19	20.16	2
	6	0	1	19.96	20.00	19.87	2

Band / BW	RB Size	RB Offset	RB Index	16QAM			3GPP MPR (dB)
				Low Ch 19965	Mid Ch 20175	High Ch 20385	
				1711.5 MHz	1732.5 MHz	1753.5 MHz	
4 / 3M	1	0	0	21.02	21.03	21.00	1
	1	5	0	21.04	20.94	21.02	1
	1	0	1	21.05	21.08	21.01	1
	1	5	1	21.08	21.05	20.89	1
	3	0	0	20.08	20.04	19.87	2
	3	3	1	19.96	20.05	19.99	2
	5	0	0	20.09	20.02	20.10	2
	5	0	1	20.02	19.96	20.01	2

Band / BW	RB Size	RB Offset	RB Index	QPSK			3GPP MPR (dB)
				Low Ch 19975	Mid Ch 20175	High Ch 20375	
				1712.5 MHz	1732.5 MHz	1752.5 MHz	
4 / 5M	1	0	0	22.13	22.05	22.05	0
	1	5	0	22.05	22.01	22.11	0
	1	0	1	21.99	22.10	22.23	0
	1	5	1	22.09	21.94	22.03	0
	1	0	3	22.06	22.08	22.18	0
	1	5	3	22.05	21.97	22.12	0
	3	0	0	21.04	21.00	21.19	1
	3	3	3	21.10	21.13	21.02	1
	6	0	0	21.30	21.25	21.35	1
	6	0	1	21.04	21.05	21.07	1
	6	0	3	21.08	21.06	21.12	1

Band / BW	RB Size	RB Offset	RB Index	16QAM			3GPP MPR (dB)
				Low Ch 19975	Mid Ch 20175	High Ch 20375	
				1712.5 MHz	1732.5 MHz	1752.5 MHz	
4 / 5M	1	0	0	21.08	21.09	21.09	1
	1	5	0	20.98	21.06	21.20	1
	1	0	1	21.16	21.17	21.21	1
	1	5	1	20.96	21.12	21.08	1
	1	0	3	21.12	21.00	21.05	1
	1	5	3	21.10	20.95	21.12	1
	3	0	0	21.01	21.13	21.19	1
	3	3	3	21.02	20.92	21.10	1
	5	0	0	20.03	19.97	20.11	2
	5	0	1	20.09	20.18	20.04	2
5	0	3	20.08	20.13	20.15	2	

Band / BW	RB Size	RB Offset	RB Index	QPSK			3GPP MPR (dB)
				Low Ch 20000	Mid Ch 20175	High Ch 20350	
				1715 MHz	1732.5 MHz	1750 MHz	
4 / 10M	1	0	0	22.16	22.03	22.20	0
	1	5	0	22.02	22.00	22.12	0
	1	0	3	22.15	21.98	22.20	0
	1	5	3	22.06	22.03	22.10	0
	1	0	7	22.13	22.15	22.25	0
	1	5	7	22.16	22.08	22.07	0
	4	0	0	22.15	22.02	22.17	0
	4	2	7	22.22	21.97	22.04	0
	6	0	0	21.32	21.23	21.35	1
	6	0	7	21.06	21.01	21.17	1

Band / BW	RB Size	RB Offset	RB Index	16QAM			3GPP MPR (dB)
				Low Ch 20000	Mid Ch 20175	High Ch 20350	
				1715 MHz	1732.5 MHz	1750 MHz	
4 / 10M	1	0	0	21.07	21.12	21.05	1
	1	5	0	21.04	21.07	21.22	1
	1	0	3	21.16	20.99	21.19	1
	1	5	3	21.10	21.01	21.07	1
	1	0	7	21.15	21.11	21.11	1
	1	5	7	21.05	21.00	21.18	1
	4	2	0	21.19	20.98	21.14	1
	4	2	7	21.14	20.96	21.13	1
	5	0	0	21.15	20.92	21.09	1
	5	0	7	21.08	20.93	21.26	1

Band / BW	RB Size	RB Offset	RB Index	QPSK			3GPP MPR (dB)
				Low Ch 20025	Mid Ch 20175	High Ch 20325	
				1717.5 MHz	1732.5 MHz	1747.5 MHz	
4 / 15M	1	0	0	22.33	22.17	22.07	0
	1	5	0	22.28	22.26	22.10	0
	1	0	5	22.29	22.12	22.22	0
	1	5	5	22.29	22.30	22.18	0
	1	0	11	22.28	22.19	21.97	0
	1	5	11	22.20	22.19	22.15	0
	3	0	0	22.24	22.08	22.09	0
	3	3	11	22.01	22.03	21.99	0
	6	0	0	21.98	21.99	21.98	0
	6	0	11	21.97	22.03	21.96	0

Band / BW	RB Size	RB Offset	RB Index	16QAM			3GPP MPR (dB)
				Low Ch 20025	Mid Ch 20175	High Ch 20325	
				1717.5 MHz	1732.5 MHz	1747.5 MHz	
4 / 15M	1	0	0	22.01	22.12	22.14	0
	1	5	0	22.00	22.12	22.12	0
	1	0	5	22.16	22.07	22.10	0
	1	5	5	22.03	22.00	22.09	0
	1	0	11	22.08	22.15	22.09	0
	1	5	11	22.13	22.15	22.10	0
	3	0	0	22.01	22.09	22.00	0
	3	3	11	22.02	22.13	22.06	0
	5	0	0	22.00	22.11	22.03	0
	5	0	11	22.09	22.08	22.00	0

Band / BW	RB Size	RB Offset	RB Index	QPSK			3GPP MPR (dB)
				Low Ch 20050	Mid Ch 20175	High Ch 20300	
				1720 MHz	1732.5 MHz	1745 MHz	
4 / 20M	1	0	0	22.35	22.12	22.04	0
	1	5	0	22.14	22.13	22.18	0
	1	0	7	22.20	22.18	22.20	0
	1	5	7	22.25	22.25	22.06	0
	1	0	15	22.12	22.22	22.22	0
	1	5	15	22.13	22.16	22.22	0
	3	0	0	22.10	22.18	22.08	0
	3	3	15	22.09	22.24	21.96	0
	6	0	0	22.07	22.16	21.98	0
	6	0	15	22.08	22.14	21.96	0

Band / BW	RB Size	RB Offset	RB Index	16QAM			3GPP MPR (dB)
				Low Ch 20050	Mid Ch 20175	High Ch 20300	
				1720 MHz	1732.5 MHz	1745 MHz	
4 / 20M	1	0	0	22.04	22.20	22.07	0
	1	5	0	22.04	22.10	22.07	0
	1	0	7	22.13	22.16	21.94	0
	1	5	7	22.22	22.25	22.05	0
	1	0	15	22.09	22.17	22.01	0
	1	5	15	22.24	22.18	22.11	0
	3	0	0	22.15	22.10	21.94	0
	3	3	15	22.08	22.18	21.99	0
	5	0	0	22.13	22.17	21.95	0
	5	0	15	22.12	22.13	22.06	0

LTE Band 12

Band / BW	RB Size	RB Offset	RB Index	QPSK			3GPP MPR (dB)
				Low Ch 23017	Mid Ch 23095	High Ch 23173	
				699.7 MHz	707.5 MHz	715.3 MHz	
12 / 1.4M	1	0	0	21.98	21.85	21.95	0
	1	5	0	21.87	21.84	21.85	0
	3	3	0	21.87	21.85	21.98	1
	6	0	0	21.12	21.10	21.10	2

Band / BW	RB Size	RB Offset	RB Index	16QAM			3GPP MPR (dB)
				Low Ch 23017	Mid Ch 23095	High Ch 23173	
				699.7 MHz	707.5 MHz	715.3 MHz	
12 / 1.4M	1	0	0	21.88	21.83	21.93	1
	1	5	0	21.97	21.79	21.87	1
	3	0	0	21.01	20.84	20.97	2
	5	0	0	20.97	20.84	20.86	2

Band / BW	RB Size	RB Offset	RB Index	QPSK			3GPP MPR (dB)
				Low Ch 23025	Mid Ch 23095	High Ch 23165	
				700.5 MHz	701.5 MHz	714.5 MHz	
12 / 3M	1	0	0	22.55	22.55	22.41	0
	1	5	0	22.45	22.49	22.38	0
	1	0	1	22.39	22.38	22.27	0
	1	5	1	22.37	22.42	22.26	0
	3	3	0	21.90	22.03	21.76	1
	3	3	1	21.99	22.05	21.95	1
	6	0	0	21.19	21.12	21.09	2
	6	0	1	20.98	21.03	20.84	2

Band / BW	RB Size	RB Offset	RB Index	16QAM			3GPP MPR (dB)
				Low Ch 23025	Mid Ch 23095	High Ch 23165	
				700.5 MHz	701.5 MHz	714.5 MHz	
12 / 3M	1	0	0	21.94	21.88	21.77	1
	1	5	0	22.03	21.93	21.93	1
	1	0	1	21.90	21.91	21.94	1
	1	5	1	21.97	21.86	21.76	1
	3	0	0	21.12	21.01	20.84	2
	3	3	1	21.04	20.85	20.73	2
	5	0	0	21.07	21.06	20.89	2
	5	0	1	21.03	20.98	20.77	2

Band / BW	RB Size	RB Offset	RB Index	QPSK			3GPP MPR (dB)
				Low Ch 23035	Mid Ch 23095	High Ch 23155	
				701.5 MHz	707.5 MHz	713.5 MHz	
12 / 5M	1	0	0	22.56	22.47	22.57	0
	1	5	0	22.52	22.51	22.51	0
	1	0	1	22.48	22.31	22.46	0
	1	5	1	22.33	22.28	22.49	0
	1	0	3	22.37	22.43	22.48	0
	1	5	3	22.27	22.41	22.37	0
	3	0	0	21.57	21.96	22.03	1
	3	3	3	21.64	21.96	22.01	1
	6	0	0	21.82	22.22	22.25	1
	6	0	1	21.74	22.01	22.04	1
	6	0	3	21.76	21.98	21.99	1

Band / BW	RB Size	RB Offset	RB Index	16QAM			3GPP MPR (dB)
				Low Ch 23035	Mid Ch 23095	High Ch 23155	
				701.5 MHz	707.5 MHz	713.5 MHz	
12 / 5M	1	0	0	21.75	21.94	22.05	1
	1	5	0	21.59	22.08	22.09	1
	1	0	1	21.66	22.05	22.14	1
	1	5	1	21.67	21.92	22.14	1
	1	0	3	21.60	21.95	22.04	1
	1	5	3	21.71	21.90	22.08	1
	3	0	0	21.56	21.91	22.15	1
	3	3	3	21.64	22.12	22.08	1
	5	0	0	20.65	20.89	21.14	2
	5	0	1	20.71	20.96	21.03	2
5	0	3	20.56	21.05	20.97	2	

Band / BW	RB Size	RB Offset	RB Index	QPSK			3GPP MPR (dB)
				Low Ch 23060	Mid Ch 23095	High Ch 23130	
				704 MHz	707.5 MHz	711 MHz	
12 / 10M	1	0	0	22.46	22.34	22.46	0
	1	5	0	22.37	22.29	22.34	0
	1	0	3	22.36	22.36	22.25	0
	1	5	3	22.41	22.41	22.19	0
	1	0	7	22.31	22.32	22.51	0
	1	5	7	22.41	22.33	22.55	0
	4	0	0	22.34	22.22	22.43	0
	4	2	7	22.32	22.43	22.47	0
	6	0	0	22.22	22.16	21.80	1
	6	0	7	22.01	21.94	21.53	1

Band / BW	RB Size	RB Offset	RB Index	16QAM			3GPP MPR (dB)
				Low Ch 23060	Mid Ch 23095	High Ch 23130	
				704 MHz	707.5 MHz	711 MHz	
12 / 10M	1	0	0	21.94	21.94	21.60	1
	1	5	0	22.11	21.93	21.67	1
	1	0	3	22.09	22.06	21.68	1
	1	5	3	21.96	22.01	21.49	1
	1	0	7	22.09	21.99	21.64	1
	1	5	7	22.00	22.06	21.68	1
	4	2	0	22.00	22.06	21.63	1
	4	2	7	22.08	22.02	21.70	1
	5	0	0	22.12	22.09	21.53	1
	5	0	7	22.15	22.13	21.51	1

EIRP / ERP POWER
LTE Band 4

QPSK			
Band 4 / 1.4M			
Channel No.	FREQUENCY (MHz)	EIRP POWER	
		dBm	mW
19957	1710.7	24.93	311.172
20175	1732.5	24.95	312.608
20393	1754.3	24.99	315.500
Band 4 / 3M			
Channel No.	FREQUENCY (MHz)	EIRP POWER	
		dBm	mW
19965	1711.5	25.06	320.627
20175	1732.5	25.06	320.627
20385	1753.5	25.07	321.366
Band 4 / 5M			
Channel No.	FREQUENCY (MHz)	EIRP POWER	
		dBm	mW
19975	1712.5	25.13	325.837
20175	1732.5	25.10	323.594
20375	1752.5	25.23	333.426
Band 4 / 10M			
Channel No.	FREQUENCY (MHz)	EIRP POWER	
		dBm	mW
20000	1715	25.22	332.660
20175	1732.5	25.15	327.341
20350	1750	25.25	334.965
Band 4 / 15M			
Channel No.	FREQUENCY (MHz)	EIRP POWER	
		dBm	mW
20025	1717.5	25.33	341.193
20175	1732.5	25.30	338.844
20325	1747.5	25.22	332.660
Band 4 / 20M			
Channel No.	FREQUENCY (MHz)	EIRP POWER	
		dBm	mW
20050	1720	25.35	342.768
20175	1732.5	25.25	334.965
20300	1745	25.22	332.660

16QAM			
Band 4 / 1.4M			
Channel No.	FREQUENCY (MHz)	EIRP POWER	
		dBm	mW
19957	1710.7	24.01	251.768
20175	1732.5	23.94	247.742
20393	1754.3	23.95	248.313
Band 4 / 3M			
Channel No.	FREQUENCY (MHz)	EIRP POWER	
		dBm	mW
19965	1711.5	24.08	255.859
20175	1732.5	24.08	255.859
20385	1753.5	24.02	252.348
Band 4 / 5M			
Channel No.	FREQUENCY (MHz)	EIRP POWER	
		dBm	mW
19975	1712.5	24.16	260.615
20175	1732.5	24.17	261.216
20375	1752.5	24.21	263.633
Band 4 / 10M			
Channel No.	FREQUENCY (MHz)	EIRP POWER	
		dBm	mW
20000	1715	24.19	262.422
20175	1732.5	24.12	258.226
20350	1750	24.26	266.686
Band 4 / 15M			
Channel No.	FREQUENCY (MHz)	EIRP POWER	
		dBm	mW
20025	1717.5	25.16	328.095
20175	1732.5	25.15	327.341
20325	1747.5	25.14	326.588
Band 4 / 20M			
Channel No.	FREQUENCY (MHz)	EIRP POWER	
		dBm	mW
20025	1717.5	25.24	334.195
20175	1732.5	25.25	334.965
20325	1747.5	25.11	324.340

LTE Band 12

QPSK			
Band 12 / 1.4M			
Channel No.	FREQUENCY (MHz)	ERP POWER	
		dBm	mW
23017	699.7	21.83	152.405
23095	707.5	21.70	147.911
23173	715.3	21.83	152.405
Band 12 / 3M			
Channel No.	FREQUENCY (MHz)	ERP POWER	
		dBm	mW
23025	700.5	22.40	173.780
23095	707.5	22.40	173.780
23165	714.5	22.26	168.267
Band 12 / 5M			
Channel No.	FREQUENCY (MHz)	ERP POWER	
		dBm	mW
23035	701.5	22.41	174.181
23095	707.5	22.36	172.187
23155	713.5	22.42	174.582
Band 12 / 10M			
Channel No.	FREQUENCY (MHz)	ERP POWER	
		dBm	mW
23060	704	22.31	170.216
23095	707.5	22.28	169.044
23130	711	22.40	173.780

16QAM			
Band 12 / 1.4M			
Channel No.	FREQUENCY (MHz)	ERP POWER	
		dBm	mW
23017	699.7	21.82	152.055
23095	707.5	21.68	147.231
23173	715.3	21.78	150.661
Band 12 / 3M			
Channel No.	FREQUENCY (MHz)	ERP POWER	
		dBm	mW
23025	700.5	21.88	154.170
23095	707.5	21.78	150.661
23165	714.5	21.79	151.008
Band 12 / 5M			
Channel No.	FREQUENCY (MHz)	ERP POWER	
		dBm	mW
23035	701.5	21.60	144.544
23095	707.5	21.97	157.398
23155	713.5	22.00	158.489
Band 12 / 10M			
Channel No.	FREQUENCY (MHz)	ERP POWER	
		dBm	mW
23060	704	22.00	158.489
23095	707.5	21.98	157.761
23130	711	21.55	142.889

4.2 Modulation characteristics Measurement

4.2.1 Limits of Modulation characteristics

N/A

4.2.2 Test Procedure

Connect the EUT to Communication Simulator via the antenna connector, The frequency band is set as EUT supported Modulation and Channels, the EUT output is matched with 50 ohm load, the waveform quality and constellation of the EUT was tested.

4.2.3 Test Setup



4.2.4 Test Results

LTE Band 4

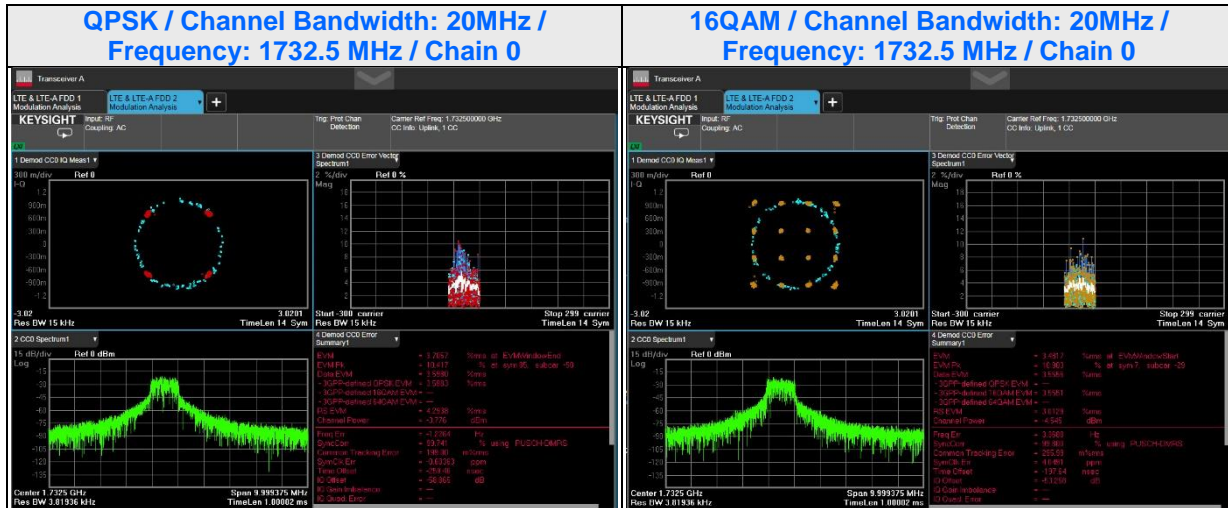

LTE Band 12

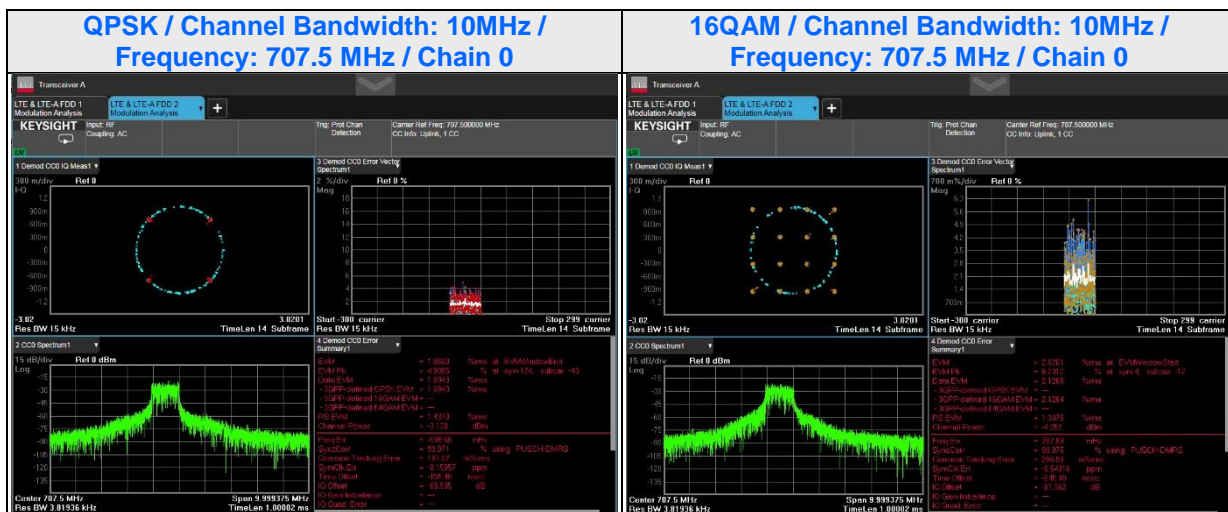

4.3 Frequency Stability Measurement

4.3.1 Limits of Frequency Stability Measurement

The frequency stability shall be sufficient to ensure that the fundamental emissions stay within the authorized bands of operation.

According to the FCC part 2.1055 shall be tested the frequency stability. The rule is defined that "The frequency stability shall be sufficient to ensure that the fundamental emission stays within the authorized frequency block." The test extreme voltage is according to the 2.1055(d)(1) Vary primary supply voltage from 85 to 115 percent of the nominal value for other than hand carried battery equipment and the extreme temperature rule is comply with specification of EUT $-30^{\circ}\text{C} \sim 50^{\circ}\text{C}$.

4.3.2 Test Procedure

- Device is placed at the oven room. The oven room could control the temperatures and humidity. Power warm up is at least 15 min and power applied should perform before recording frequency error.
- EUT is connected the external power supply to control the DC input power. The test voltage range is from minimum to maximum working voltage. Each step shall be record the frequency error rate.
- The temperature range step is 10 degrees in this test items. All temperature levels shall be hold the $\pm 0.5^{\circ}\text{C}$ during the measurement testing. The each temperature step shall be at least 0.5 hours, consider the EUT could be test under the stability condition.

NOTE: The frequency error was recorded frequency error from the communication simulator.

4.3.3 Test Setup

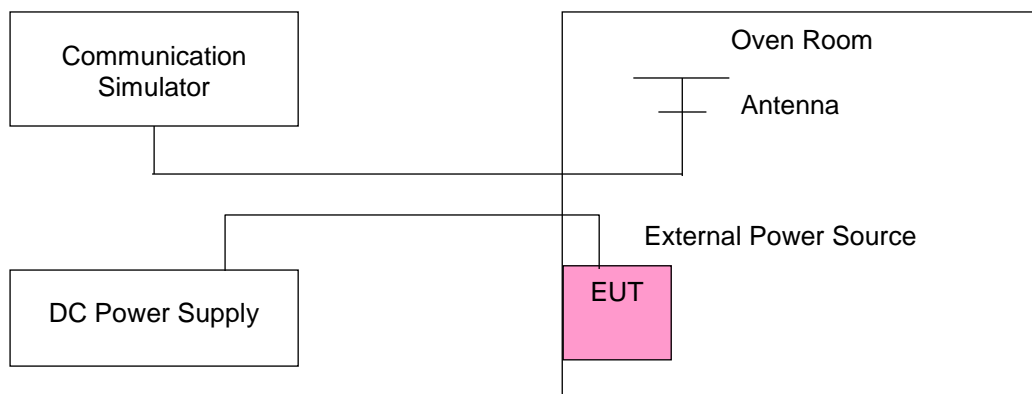

4.3.4 Test Results

LTE Band 4

Voltage (Volts)	Frequency Error (MHz)												Limit (MHz)	
	1.4MHz		3MHz		5MHz		10MHz		15MHz		20MHz		Low Edge	High Edge
	Low	High	Low	High	Low	High	Low	High	Low	High	Low	High		
2.8	1710.140	1754.961	1710.649	1754.951	1710.350	1754.849	1710.619	1754.650	1710.949	1754.421	1711.072	1754.050	1710	1755
3.8	1710.141	1754.959	1710.650	1754.951	1710.351	1754.851	1710.620	1754.649	1710.950	1754.420	1711.072	1754.050	1710	1755

Temp. (°C)	Frequency Error (MHz)												Limit (MHz)	
	1.4MHz		3MHz		5MHz		10MHz		15MHz		20MHz		Low Edge	High Edge
	Low	High	Low	High	Low	High	Low	High	Low	High	Low	High		
50	1710.140	1754.960	1710.649	1754.950	1710.350	1754.849	1710.619	1754.650	1710.951	1754.419	1711.072	1754.049	1710	1755
40	1710.140	1754.960	1710.651	1754.950	1710.350	1754.851	1710.620	1754.650	1710.951	1754.420	1711.072	1754.050	1710	1755
30	1710.140	1754.960	1710.650	1754.949	1710.350	1754.851	1710.620	1754.650	1710.950	1754.419	1711.072	1754.050	1710	1755
20	1710.139	1754.959	1710.650	1754.950	1710.350	1754.850	1710.619	1754.651	1710.949	1754.421	1711.072	1754.050	1710	1755
10	1710.140	1754.960	1710.650	1754.951	1710.350	1754.850	1710.620	1754.651	1710.950	1754.421	1711.072	1754.051	1710	1755
0	1710.140	1754.961	1710.649	1754.950	1710.350	1754.850	1710.620	1754.651	1710.950	1754.421	1711.073	1754.050	1710	1755
-10	1710.141	1754.959	1710.649	1754.951	1710.351	1754.850	1710.620	1754.650	1710.950	1754.421	1711.072	1754.050	1710	1755
-20	1710.141	1754.959	1710.650	1754.950	1710.349	1754.851	1710.620	1754.651	1710.949	1754.421	1711.072	1754.050	1710	1755
-30	1710.140	1754.960	1710.650	1754.949	1710.349	1754.851	1710.620	1754.650	1710.950	1754.421	1711.073	1754.050	1710	1755

LTE Band 12

Voltage (Volts)	Frequency Error (MHz)								Limit (MHz)	
	1.4MHz		3MHz		5MHz		10MHz			
	Low	High	Low	High	Low	High	Low	High	Low Edge	High Edge
2.8	699.110	715.770	699.140	715.700	699.110	715.770	699.500	715.420	699	716
3.8	699.110	715.770	699.140	715.701	699.109	715.771	699.501	715.420	699	716

Temp. (°C)	Frequency Error (MHz)								Limit (MHz)	
	1.4MHz		3MHz		5MHz		10MHz			
	Low	High	Low	High	Low	High	Low	High	Low Edge	High Edge
50	699.110	715.770	699.139	715.700	699.109	715.769	699.501	715.419	699	716
40	699.110	715.770	699.141	715.699	699.110	715.771	699.500	715.420	699	716
30	699.110	715.769	699.140	715.700	699.110	715.771	699.501	715.421	699	716
20	699.110	715.770	699.140	715.700	699.110	715.770	699.500	715.420	699	716
10	699.111	715.770	699.140	715.700	699.110	715.771	699.499	715.420	699	716
0	699.111	715.771	699.140	715.700	699.110	715.770	699.499	715.419	699	716
-10	699.109	715.770	699.140	715.700	699.111	715.770	699.500	715.419	699	716
-20	699.111	715.770	699.140	715.701	699.109	715.770	699.499	715.420	699	716
-30	699.109	715.771	699.139	715.701	699.111	715.769	699.500	715.421	699	716

4.4 Emission Bandwidth Measurement

4.4.1 Limits of Emission Bandwidth Measurement

-26dB Bandwidth

According to FCC 27.53 specified that emission bandwidth is defined as the width of the signal between two points, one below the carrier center frequency and one above the carrier center frequency, outside of which all emissions are attenuated at least 26dB below the transmitter power.

Occupied Bandwidth

The EUT makes a call to the communication simulator. All measurements were done at low, middle and high operational frequency range. The communication simulator station system controlled a EUT to export maximum output power under transmission mode and specific channel frequency. Use OBW measurement function of Spectrum analyzer to measure 99 % occupied bandwidth.

4.4.2 Test Procedure

The transmitter output was connected to the spectrum analyzer through an attenuator. The bandwidth of the fundamental frequency was measured by spectrum analyzer with $RBW \geq 1\% \times OBW$ and $VBW \geq 3 \times RBW$.

4.4.3 Test Setup

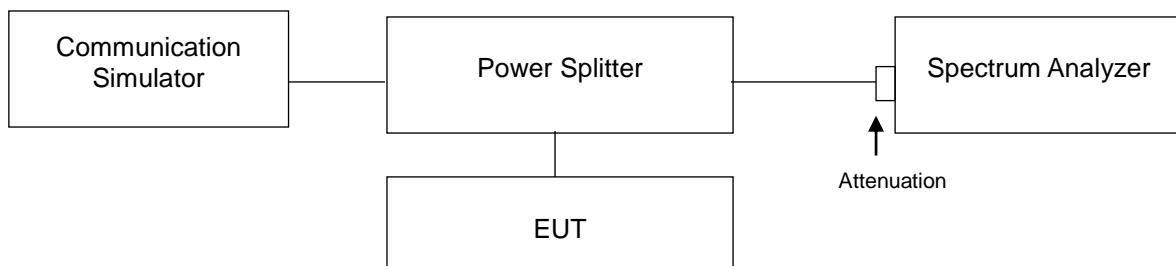

4.4.4 Test Results (-26dB Bandwidth)

LTE Band 4							
Channel Bandwidth 1.4MHz				Channel Bandwidth 3MHz			
Channel	Frequency (MHz)	-26dB Bandwidth (MHz)		Channel	Frequency (MHz)	-26dB Bandwidth (MHz)	
		QPSK	16QAM			QPSK	16QAM
19957	1710.7	1.30	1.33	19965	1711.5	2.03	1.40
20175	1732.5	1.37	1.32	20175	1732.5	1.64	1.38
20393	1754.3	1.35	1.33	20385	1753.5	1.63	1.44
Channel Bandwidth 5MHz				Channel Bandwidth 10MHz			
Channel	Frequency (MHz)	-26dB Bandwidth (MHz)		Channel	Frequency (MHz)	-26dB Bandwidth (MHz)	
		QPSK	16QAM			QPSK	16QAM
19975	1712.5	1.91	1.43	20000	1715	1.68	1.85
20175	1732.5	1.76	1.81	20175	1732.5	1.83	1.74
20375	1752.5	1.67	1.55	20350	1750	1.59	1.65
Channel Bandwidth 15MHz				Channel Bandwidth 20MHz			
Channel	Frequency (MHz)	-26dB Bandwidth (MHz)		Channel	Frequency (MHz)	-26dB Bandwidth (MHz)	
		QPSK	16QAM			QPSK	16QAM
20025	1717.5	1.77	1.84	20050	1720	1.77	1.81
20175	1732.5	1.68	1.66	20175	1732.5	1.66	1.73
20325	1747.5	1.63	1.79	20300	1745	1.70	1.74

Spectrum Plot of Worst Value

1.4MHz / QPSK

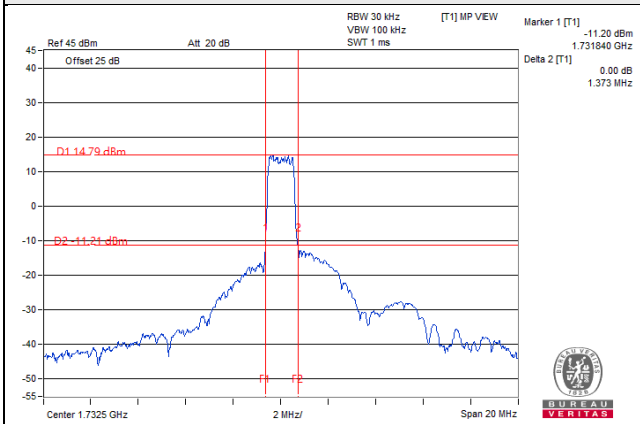

3MHz / QPSK

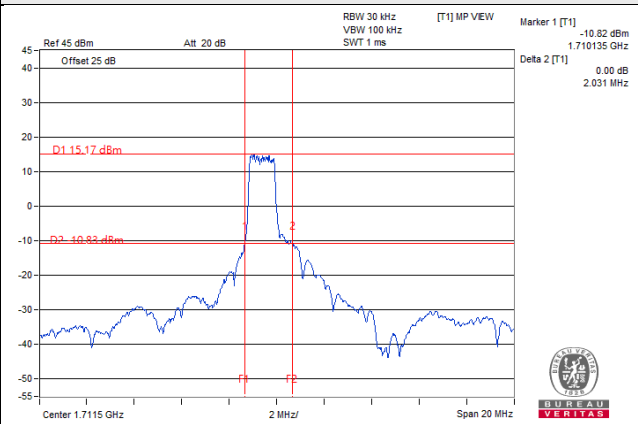

5MHz / QPSK

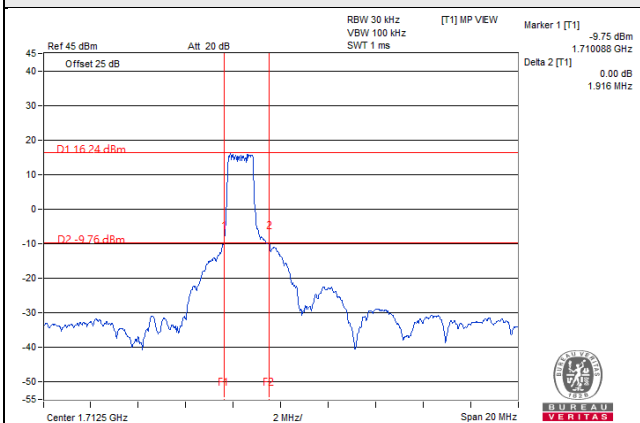

10MHz / 16QAM

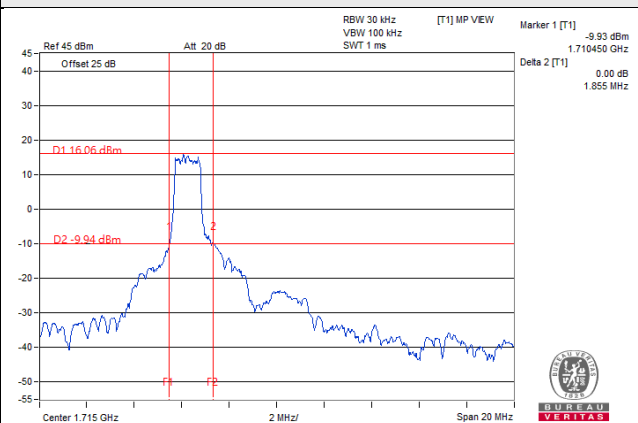

15MHz / 16QAM

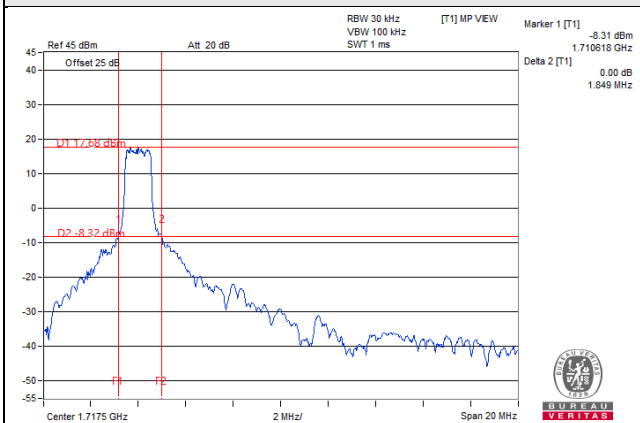

20MHz / 16QAM

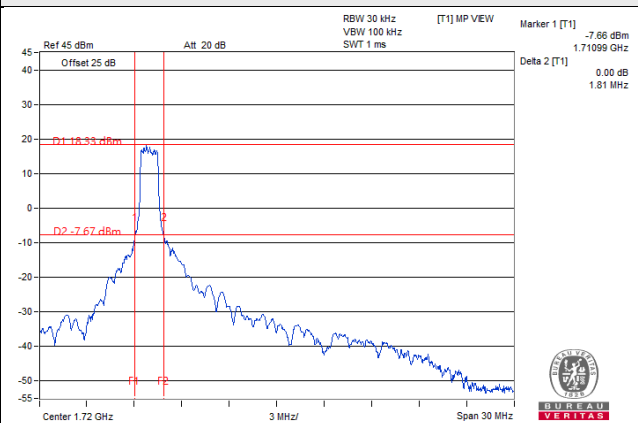

LTE Band 12

Channel Bandwidth 1.4MHz				Channel Bandwidth 3MHz			
Channel	Frequency (MHz)	-26dB Bandwidth (MHz)		Channel	Frequency (MHz)	-26dB Bandwidth (MHz)	
		QPSK	16QAM			QPSK	16QAM
23017	699.7	1.37	1.30	23025	700.5	1.73	1.39
23095	707.5	1.36	1.31	23095	707.5	2.07	1.41
23173	715.3	1.33	1.31	23165	714.5	1.73	1.40
Channel Bandwidth 5MHz				Channel Bandwidth 10MHz			
Channel	Frequency (MHz)	-26dB Bandwidth (MHz)		Channel	Frequency (MHz)	-26dB Bandwidth (MHz)	
		QPSK	16QAM			QPSK	16QAM
23035	701.5	2.02	1.84	23060	704	1.59	1.72
23095	707.5	1.77	1.65	23095	707.5	1.76	1.84
23155	713.5	1.66	1.53	23130	711	1.60	1.71

Spectrum Plot of Worst Value

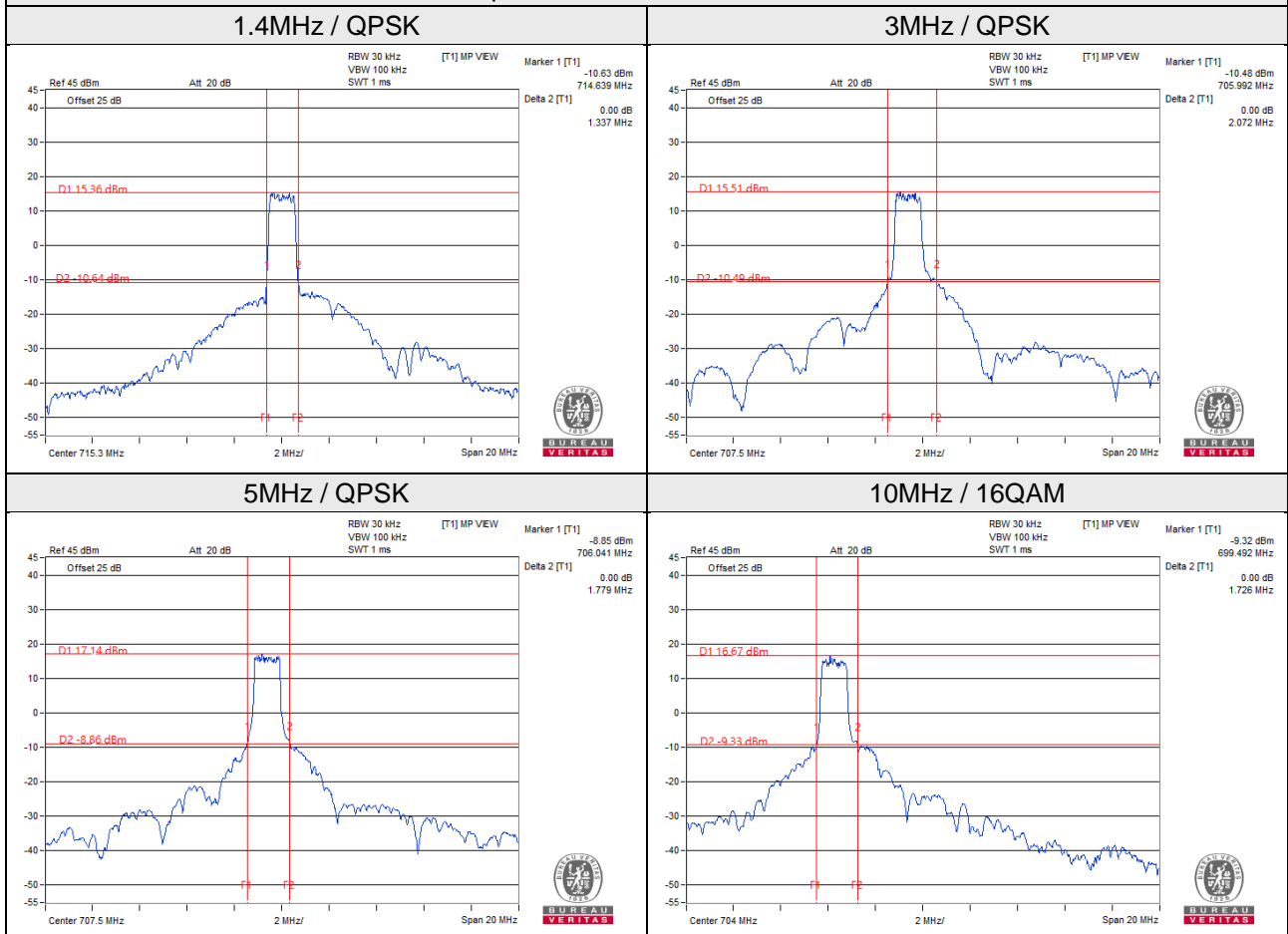

4.4.5 Test Results (Occupied Bandwidth)

LTE Band 4							
Channel Bandwidth 1.4MHz				Channel Bandwidth 3MHz			
Channel	Frequency (MHz)	Occupied Bandwidth (MHz)		Channel	Frequency (MHz)	Occupied Bandwidth (MHz)	
		QPSK	16QAM			QPSK	16QAM
19957	1710.7	1.14	1.12	19965	1711.5	1.20	1.14
20175	1732.5	1.12	1.12	20175	1732.5	1.20	1.14
20393	1754.3	1.12	1.12	20385	1753.5	1.16	1.14
Channel Bandwidth 5MHz				Channel Bandwidth 10MHz			
Channel	Frequency (MHz)	Occupied Bandwidth (MHz)		Channel	Frequency (MHz)	Occupied Bandwidth (MHz)	
		QPSK	16QAM			QPSK	16QAM
19975	1712.5	1.16	1.14	20000	1715	1.16	1.20
20175	1732.5	1.16	1.18	20175	1732.5	1.14	1.20
20375	1752.5	1.14	1.14	20350	1750	1.16	1.16
Channel Bandwidth 15MHz				Channel Bandwidth 20MHz			
Channel	Frequency (MHz)	Occupied Bandwidth (MHz)		Channel	Frequency (MHz)	Occupied Bandwidth (MHz)	
		QPSK	16QAM			QPSK	16QAM
20025	1717.5	1.14	1.20	20050	1720	1.17	1.20
20175	1732.5	1.16	1.16	20175	1732.5	1.14	1.17
20325	1747.5	1.16	1.14	20300	1745	1.14	1.17

Spectrum Plot of Worst Value

1.4MHz / QPSK

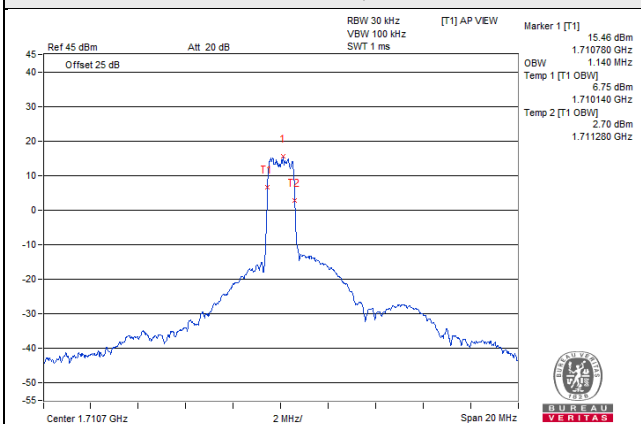

3MHz / QPSK

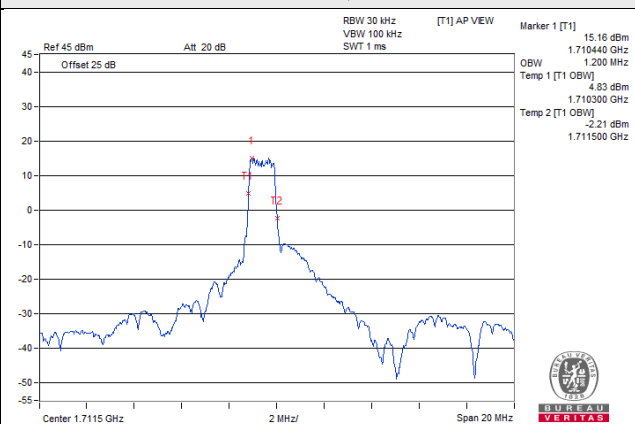

5MHz / 16QAM

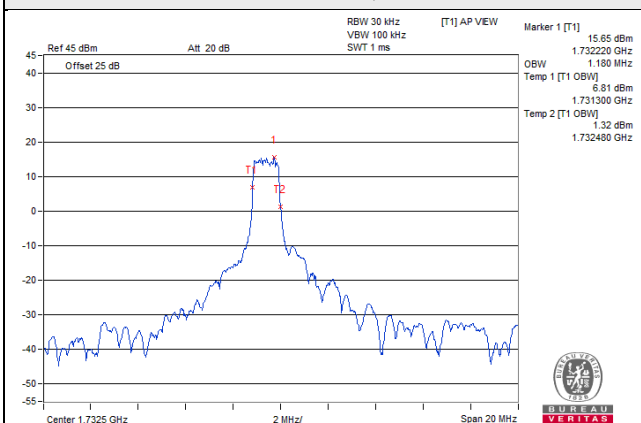

10MHz / 16QAM

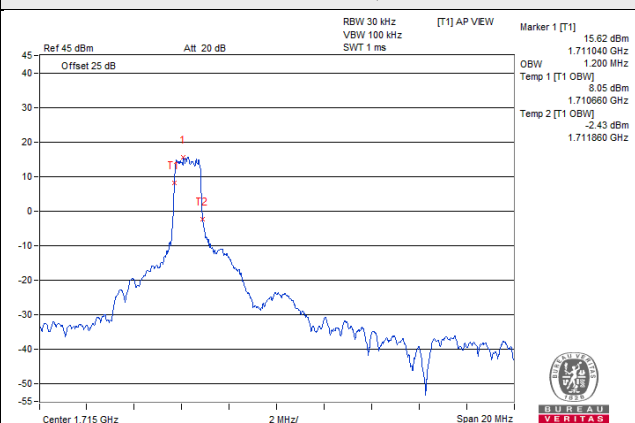

15MHz / 16QAM

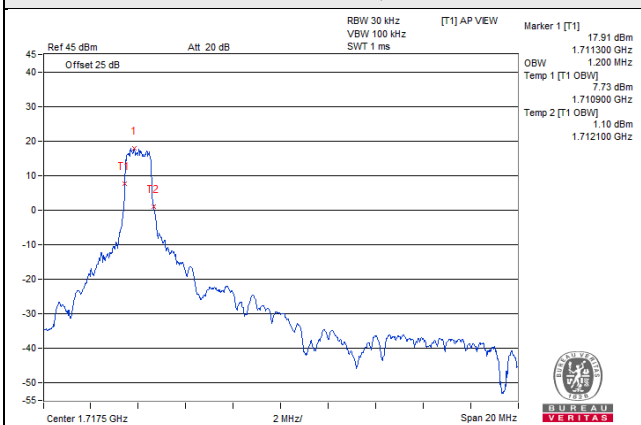

20MHz / 16QAM

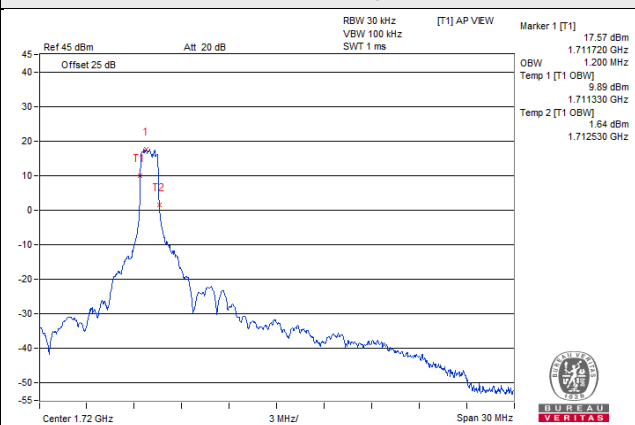

LTE Band 12

Channel Bandwidth 1.4MHz				Channel Bandwidth 3MHz			
Channel	Frequency (MHz)	Occupied Bandwidth (MHz)		Channel	Frequency (MHz)	Occupied Bandwidth (MHz)	
		QPSK	16QAM			QPSK	16QAM
23017	699.7	1.12	1.12	23025	700.5	1.18	1.14
23095	707.5	1.12	1.12	23095	707.5	1.20	1.12
23173	715.3	1.14	1.12	23165	714.5	1.14	1.14
Channel Bandwidth 5MHz				Channel Bandwidth 10MHz			
Channel	Frequency (MHz)	Occupied Bandwidth (MHz)		Channel	Frequency (MHz)	Occupied Bandwidth (MHz)	
		QPSK	16QAM			QPSK	16QAM
23035	701.5	1.18	1.14	23060	704	1.14	1.22
23095	707.5	1.20	1.18	23095	707.5	1.14	1.20
23155	713.5	1.16	1.16	23130	711	1.14	1.22

Spectrum Plot of Worst Value

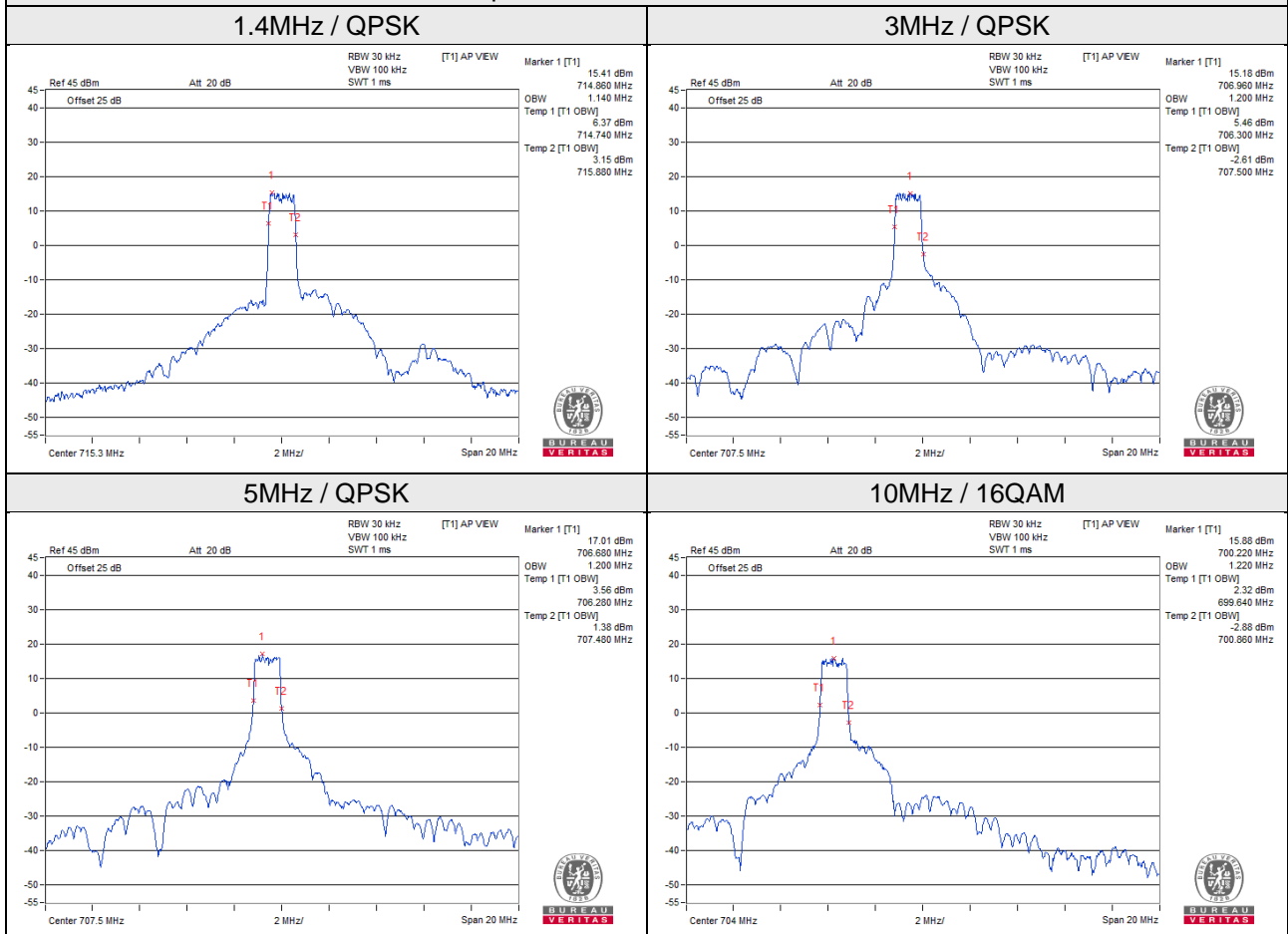

4.5 Channel Edge Measurement

4.5.1 Limits of Channel Edge Measurement

According to FCC 27.53(g) For operations in the 600 MHz band and the 698-746 MHz band, the power of any emission outside a licensee's frequency band(s) of operation shall be attenuated below the transmitter power (P) within the licensed band(s) of operation, measured in watts, by at least $43 + 10 \log (P)$ dB. Compliance with this provision is based on the use of measurement instrumentation employing a resolution bandwidth of 100 kilohertz or greater. However, in the 100 kilohertz bands immediately outside and adjacent to a licensee's frequency block, a resolution bandwidth of at least 30 kHz may be employed.

According to FCC 27.53(h) AWS emission limits— General protection levels. Except as otherwise specified below, for operations in the 1695-1710 MHz, 1710-1755 MHz, 1755-1780 MHz, 1915-1920 MHz, 1995-2000 MHz, 2000-2020 MHz, 2110-2155 MHz, 2155-2180 MHz, and 2180-2200 bands, the power of any emission outside a licensee's frequency block shall be attenuated below the transmitter power (P) in watts by at least $43 + 10 \log_{10} (P)$ dB.

4.5.2 Test Setup

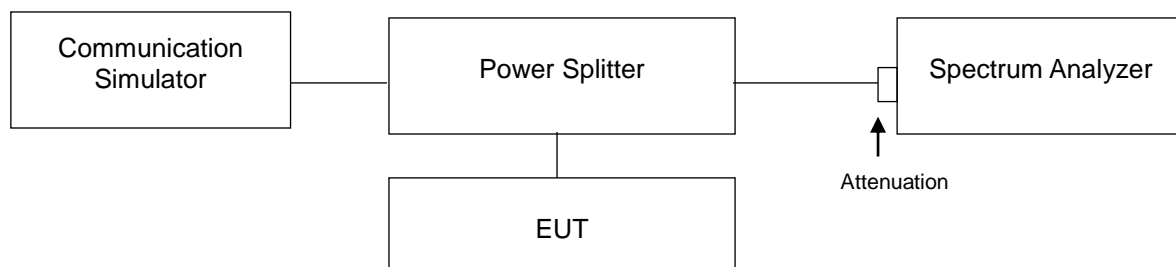

4.5.3 Test Procedures

- All measurements were done at low and high operational frequency range.
- The center frequency of spectrum is the band edge frequency and s RB of the spectrum is $>1\%$ emission bandwidth and VB of the spectrum is $\geq 3 \cdot RB$.
- Record the max trace plot into the test report.

4.5.4 Test Results

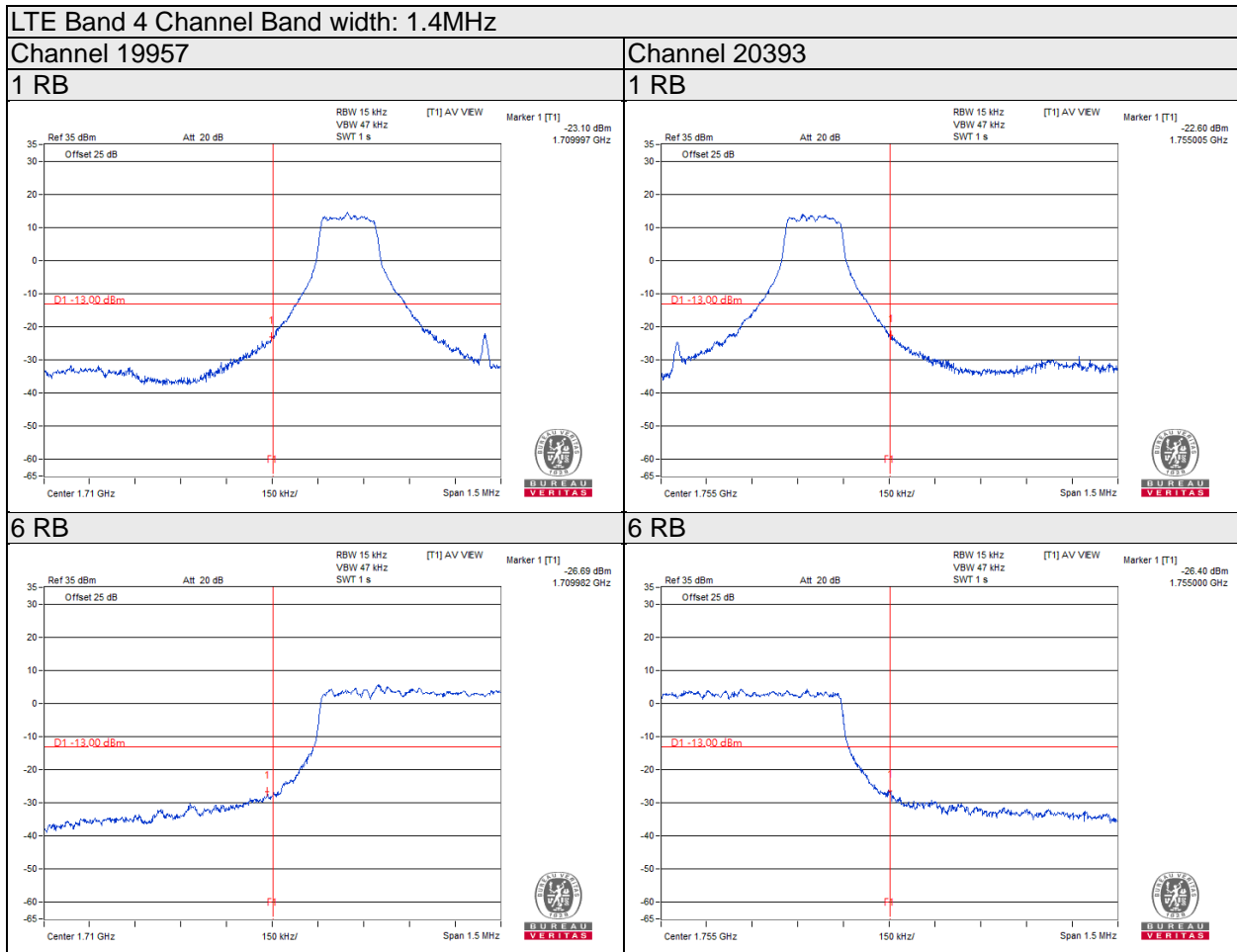

LTE Band 4 Channel Band width: 3MHz

Channel 19965

1 RB

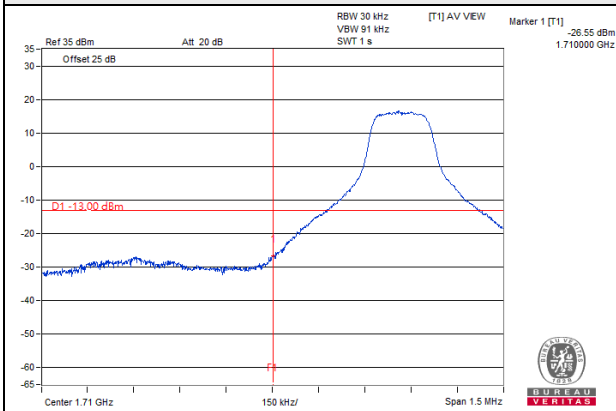

Channel 20385

1 RB

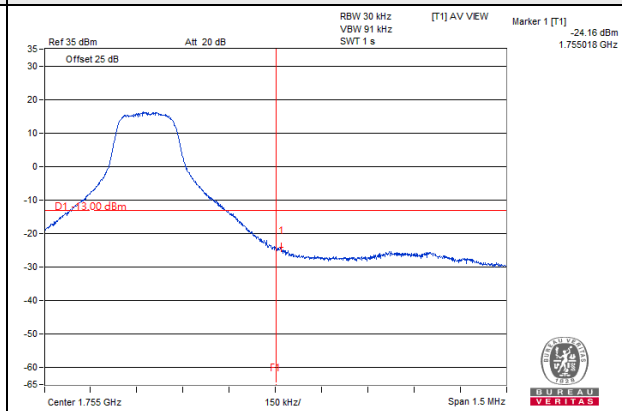

6 RB

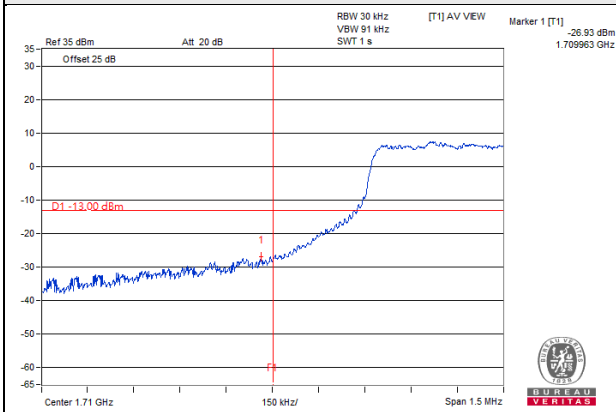

6 RB

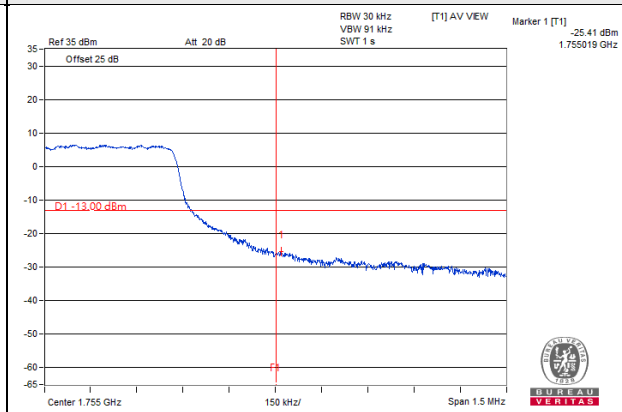

LTE Band 4 Channel Band width: 5MHz

Channel 19975

1 RB

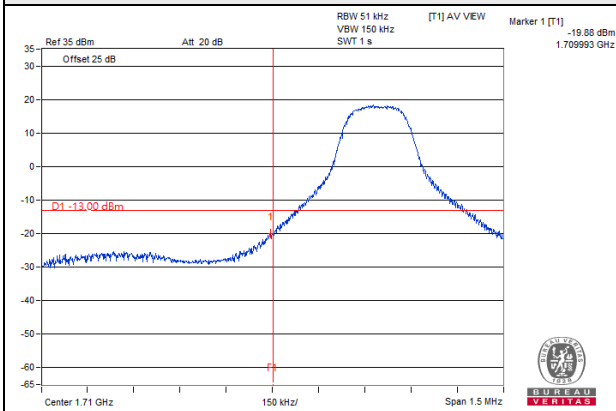

Channel 20375

1 RB

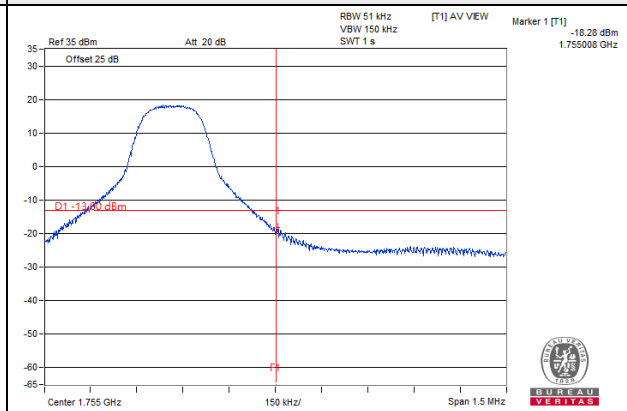

6 RB

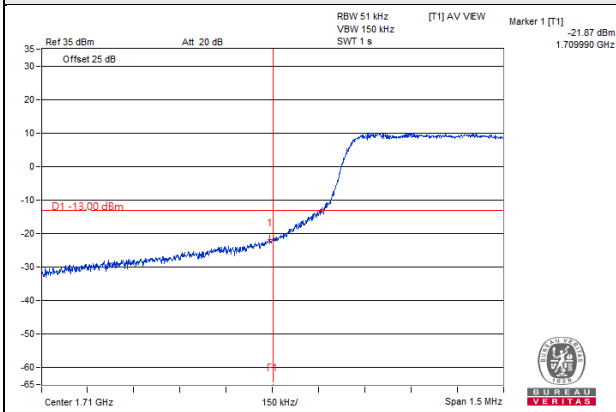

6 RB

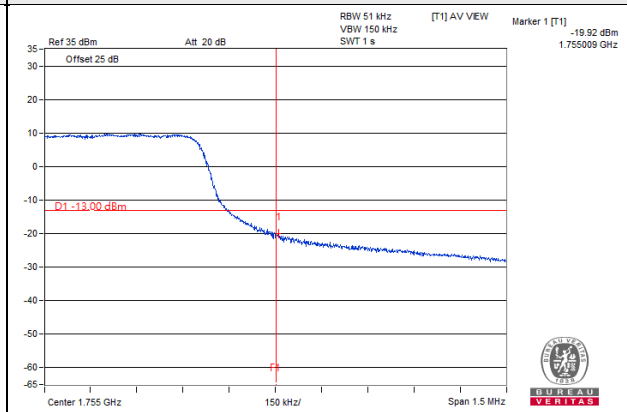

LTE Band 4 Channel Band width: 10MHz

Channel 20000

1 RB

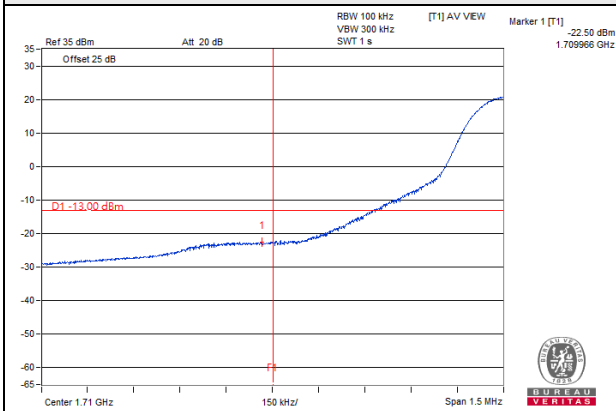

Channel 20350

1 RB

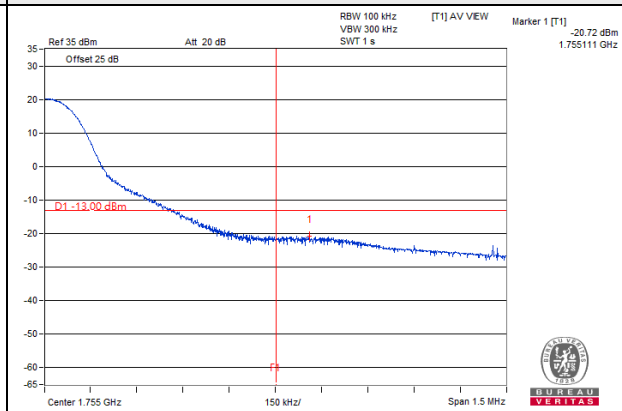

6 RB

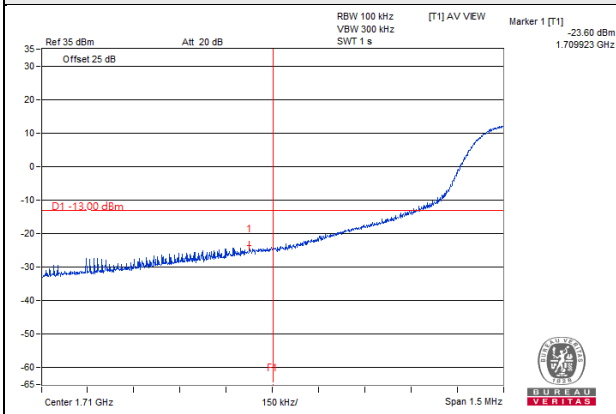

6 RB

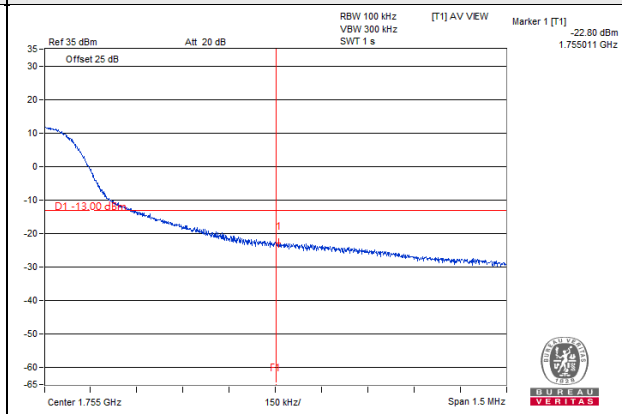

LTE Band 4 Channel Band width: 15MHz

Channel 20025

1 RB

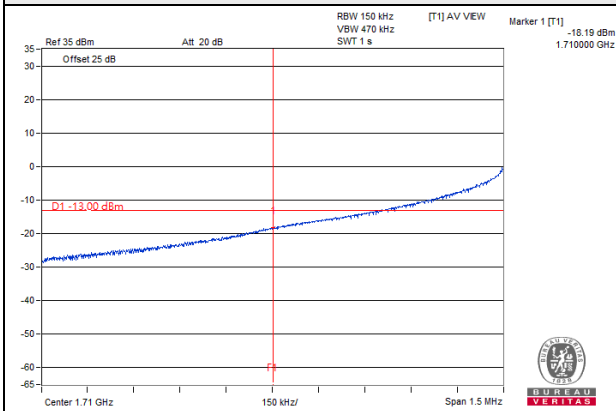

Channel 20325

1 RB

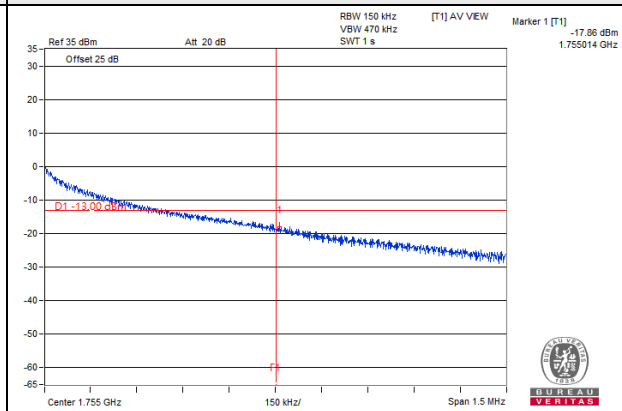

6 RB

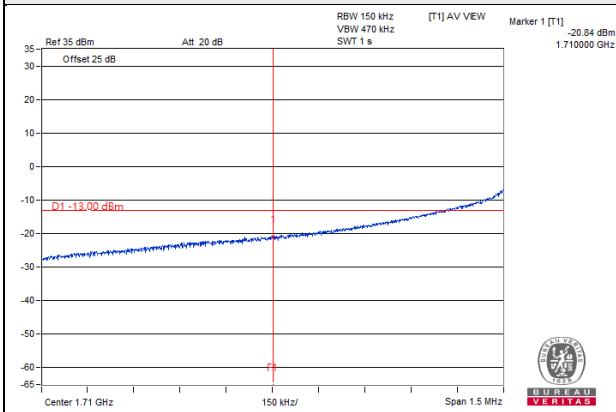

6 RB

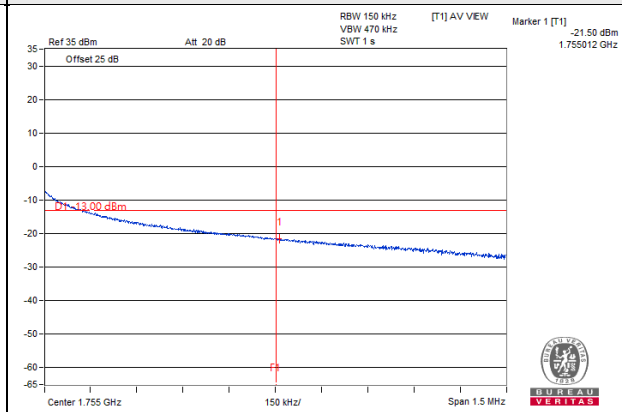

LTE Band 4 Channel Band width: 20MHz

Channel 20050

1 RB

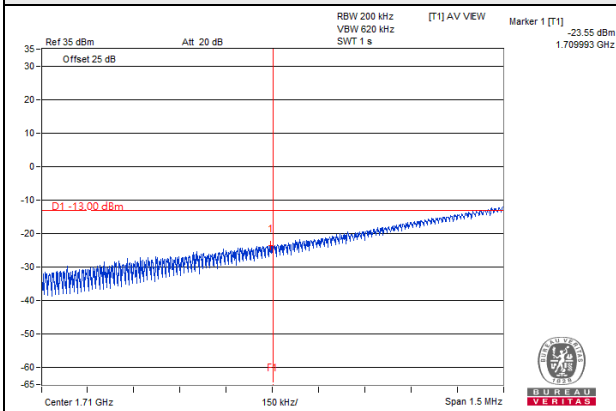

Channel 20300

1 RB

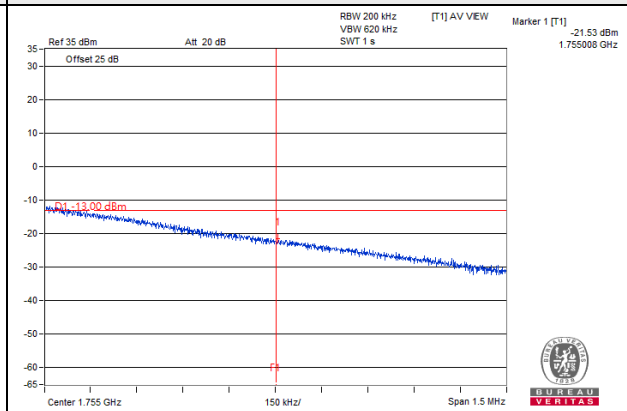

6 RB

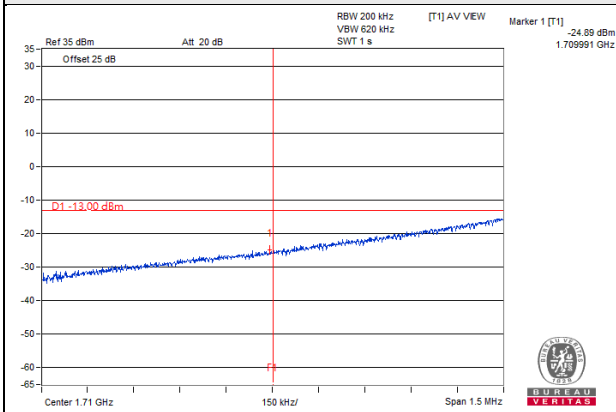

6 RB

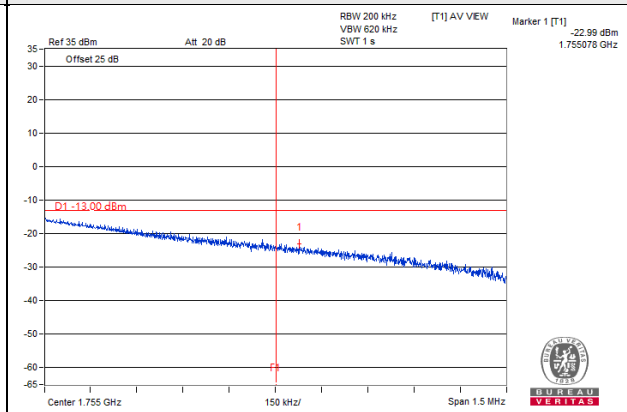

LTE Band 12 Channel Band width: 1.4MHz

Channel 23017

1 RB

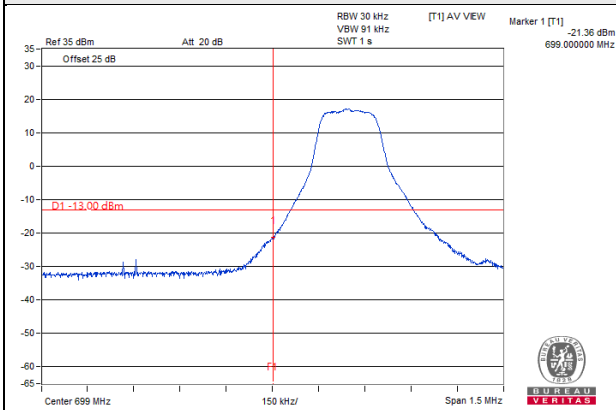

Channel 23173

1 RB

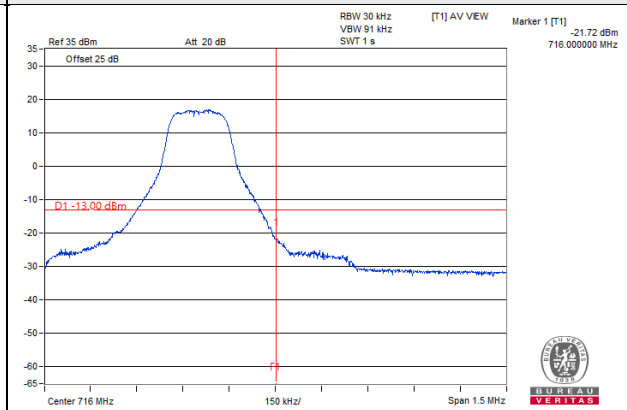

6 RB

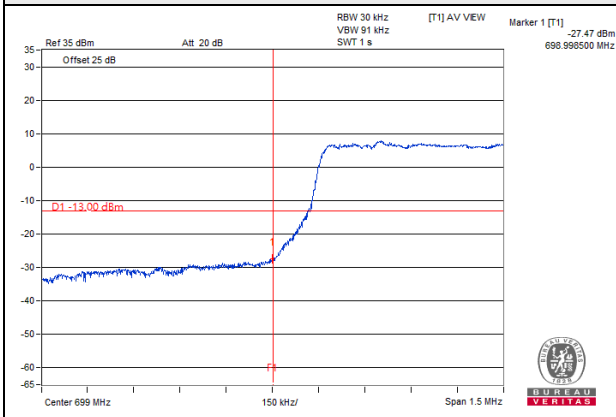

6 RB

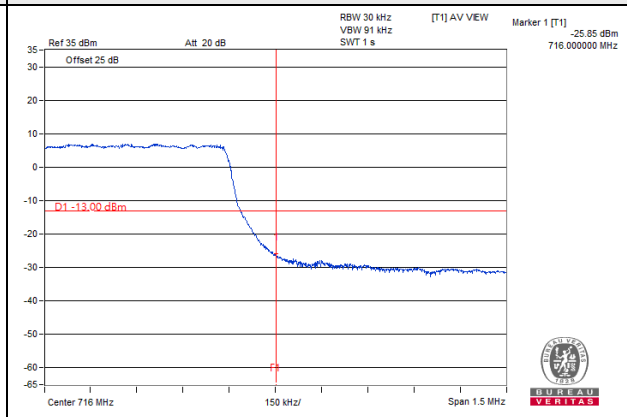

LTE Band 12 Channel Band width: 3MHz

Channel 23025

1 RB

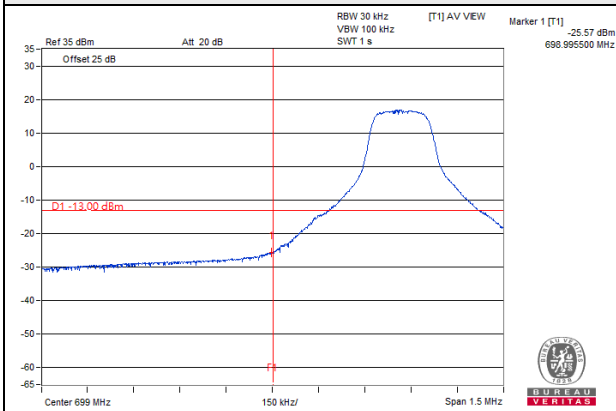

Channel 23165

1 RB

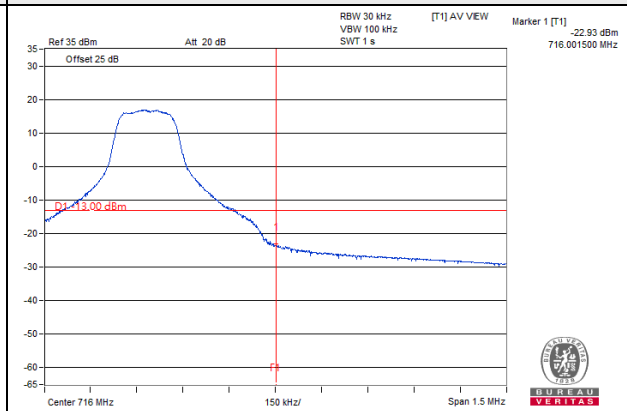

6 RB

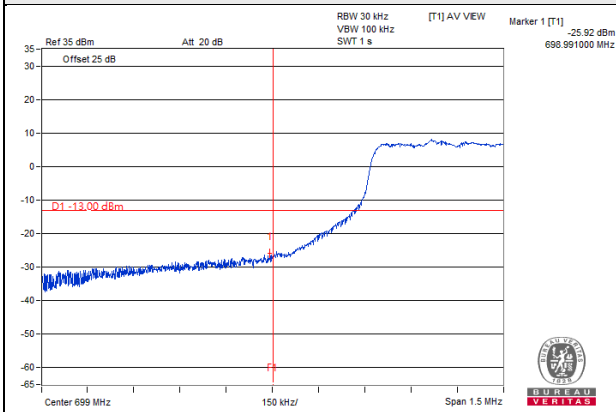

6 RB

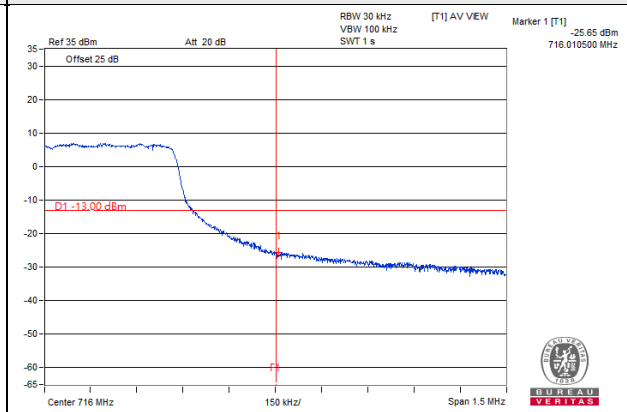

LTE Band 12 Channel Band width: 5MHz

Channel 23035

1 RB

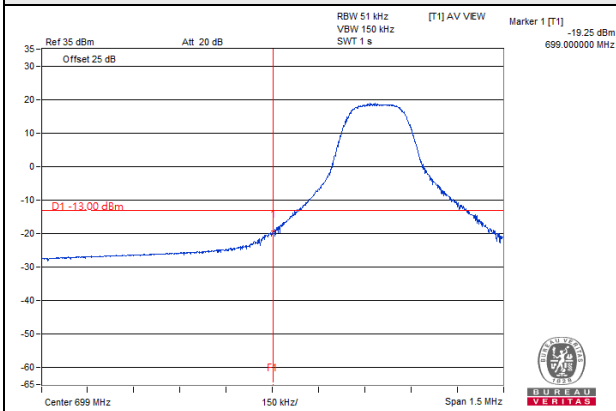

Channel 23155

1 RB

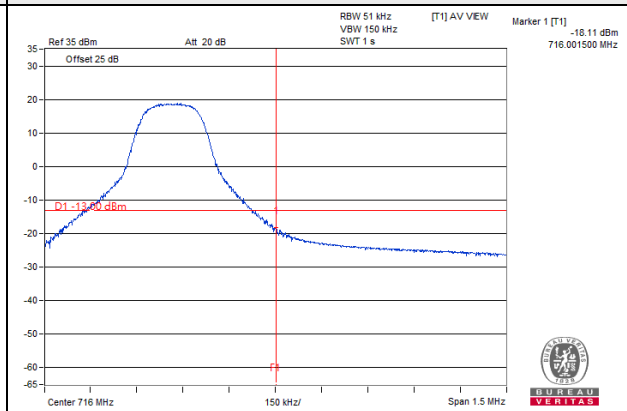

6 RB

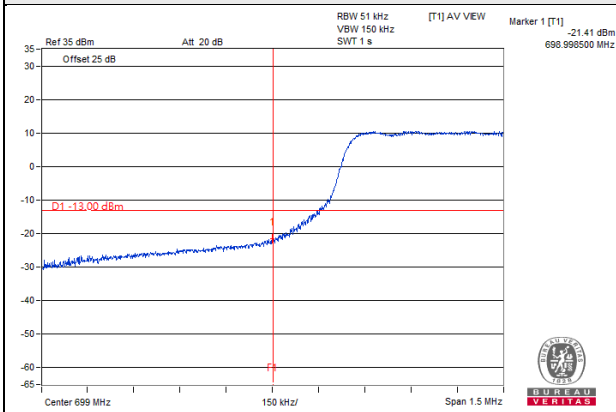

6 RB

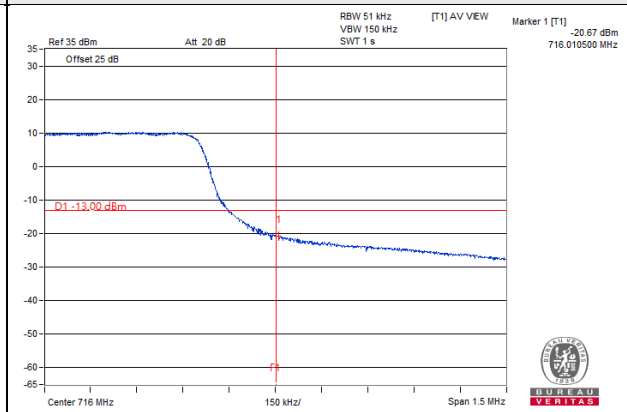

LTE Band 12 Channel Band width: 10MHz

Channel 23060

1 RB

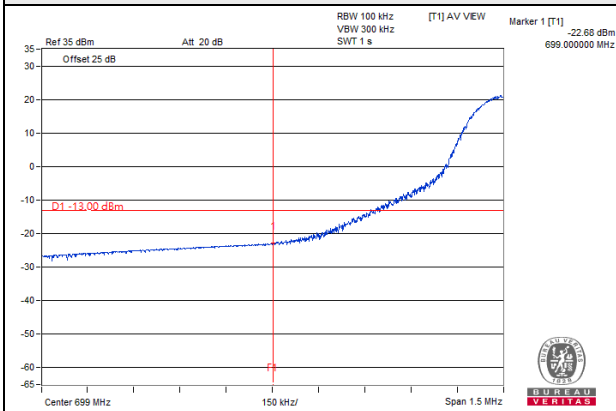

Channel 23130

1 RB

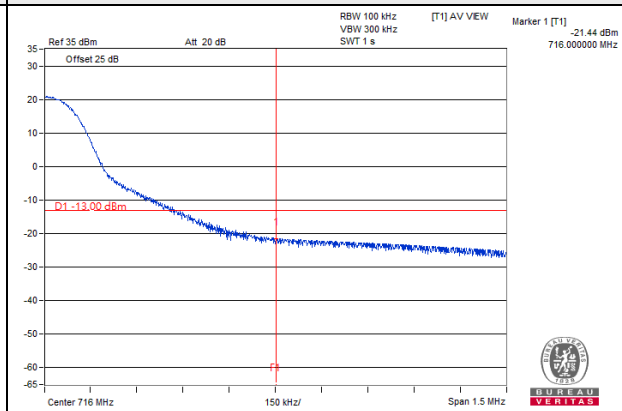

6 RB

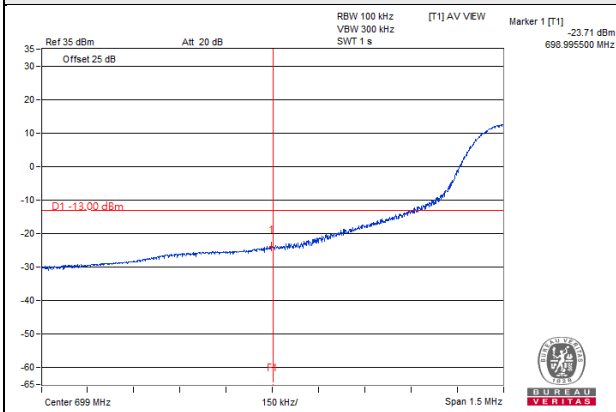

6 RB

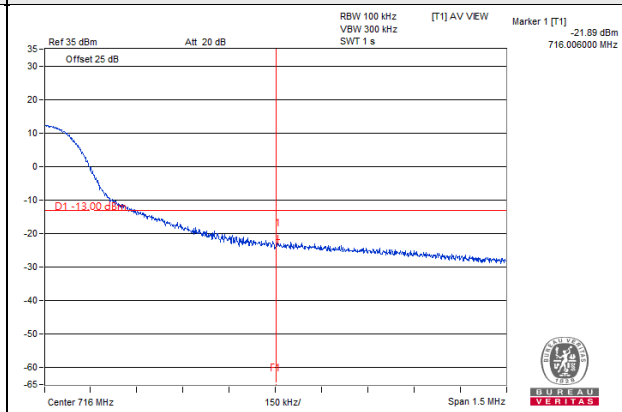

4.6 Peak to Average Ratio

4.5.1 Limits of Peak to Average Ratio Measurement

In measuring transmissions in this band using an average power technique, the peak to-average ratio (PAR) of the transmission may not exceed 13 dB

4.5.2 Test Setup

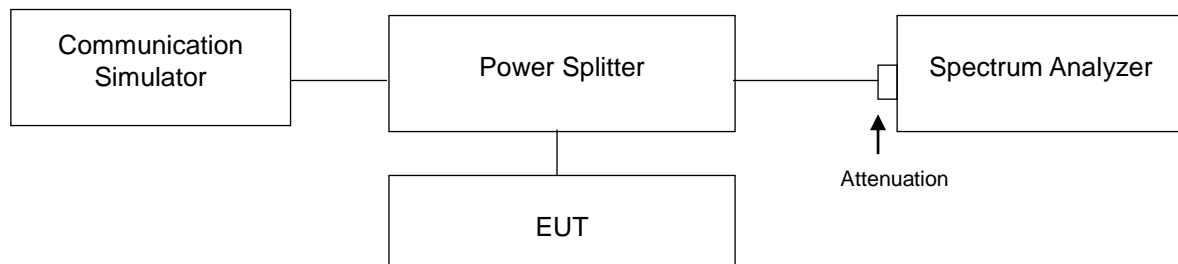

4.5.3 Test Procedures

1. Set resolution/measurement bandwidth \geq signal's occupied bandwidth;
2. Set the number of counts to a value that stabilizes the measured CCDF curve;
3. Record the maximum PAPR level associated with a probability of 0.1%.

4.5.4 Test Results

LTE Band 4							
Channel Bandwidth 1.4MHz				Channel Bandwidth 3MHz			
Channel	Frequency (MHz)	Peak To Average Ratio (dB)		Channel	Frequency (MHz)	Peak To Average Ratio (dB)	
		QPSK	16QAM			QPSK	16QAM
19957	1710.7	5.66	6.38	19965	1711.5	5.19	6.13
20175	1732.5	5.58	6.26	20175	1732.5	5.08	6.01
20393	1754.3	5.51	6.15	20385	1753.5	5.05	5.91
Channel Bandwidth 5MHz				Channel Bandwidth 10MHz			
Channel	Frequency (MHz)	Peak To Average Ratio (dB)		Channel	Frequency (MHz)	Peak To Average Ratio (dB)	
		QPSK	16QAM			QPSK	16QAM
19975	1712.5	5.20	6.12	20000	1715	5.06	6.05
20175	1732.5	4.82	5.83	20175	1732.5	4.81	5.85
20375	1752.5	4.99	5.93	20350	1750	4.86	5.83
Channel Bandwidth 15MHz				Channel Bandwidth 20MHz			
Channel	Frequency (MHz)	Peak To Average Ratio (dB)		Channel	Frequency (MHz)	Peak To Average Ratio (dB)	
		QPSK	16QAM			QPSK	16QAM
20025	1717.5	4.76	5.59	20050	1720	4.76	5.49
20175	1732.5	4.67	5.39	20175	1732.5	4.65	5.41
20325	1747.5	4.57	5.37	20300	1745	4.54	5.32

Spectrum Plot of Worst Value

1.4MHz / 16QAM

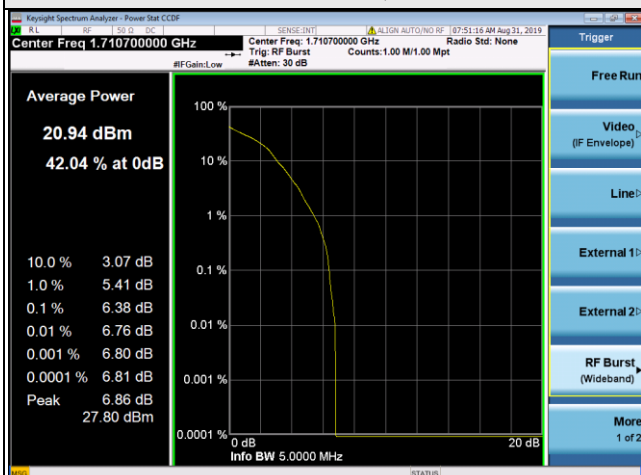

3MHz / 16QAM

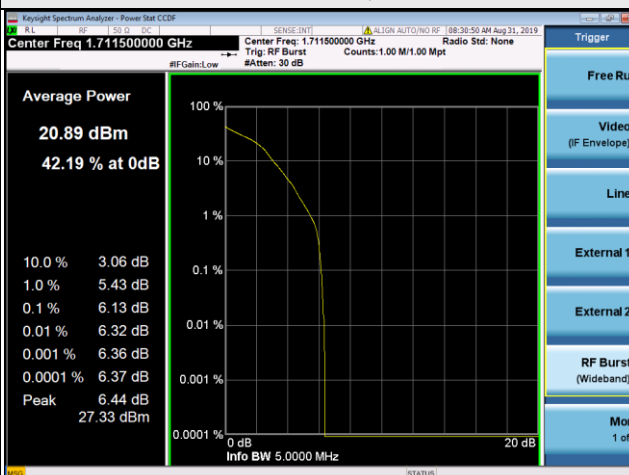

5MHz / 16QAM

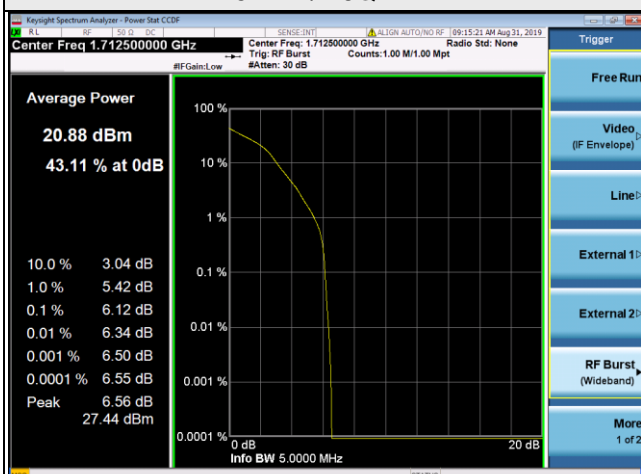

10MHz / 16QAM

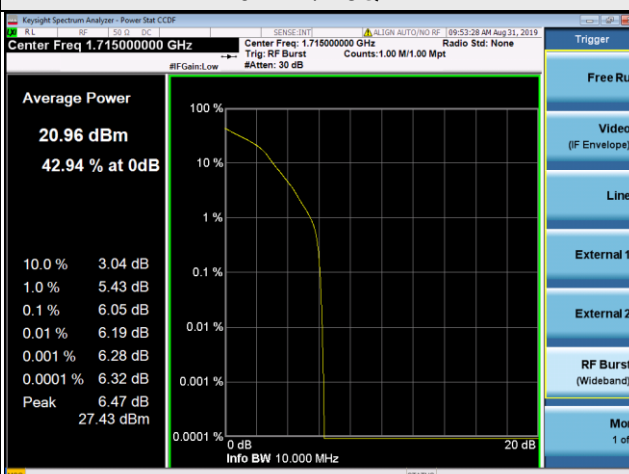

15MHz / 16QAM

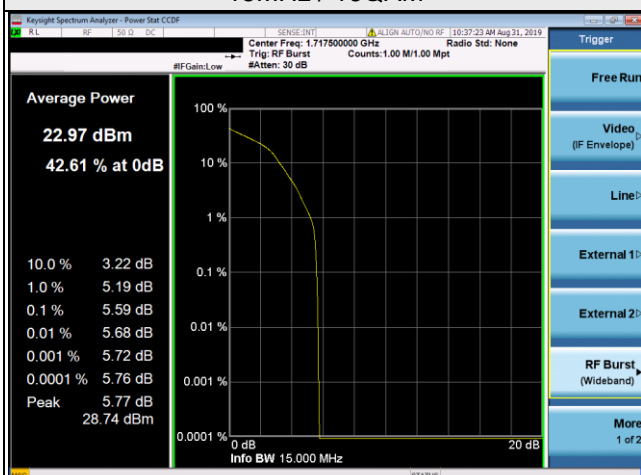

20MHz / 16QAM

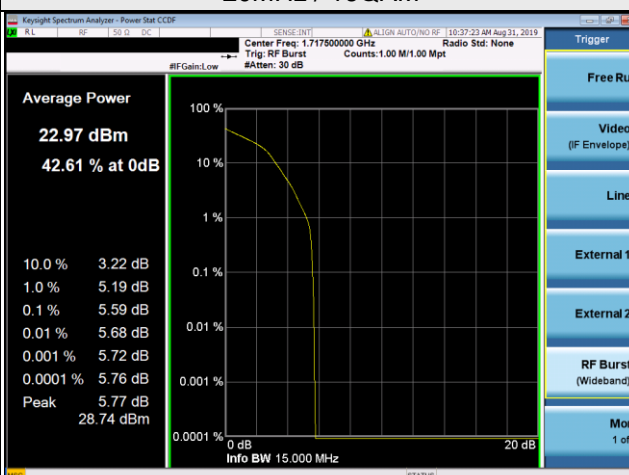

LTE Band 12							
Channel Bandwidth 1.4MHz				Channel Bandwidth 3MHz			
Channel	Frequency (MHz)	Peak To Average Ratio (dB)		Channel	Frequency (MHz)	Peak To Average Ratio (dB)	
		QPSK	16QAM			QPSK	16QAM
23017	699.7	5.69	6.67	23025	700.5	5.20	6.26
23095	707.5	5.66	6.57	23095	707.5	5.17	6.21
23173	715.3	5.62	6.53	23165	714.5	5.16	6.18
Channel Bandwidth 5MHz				Channel Bandwidth 10MHz			
Channel	Frequency (MHz)	Peak To Average Ratio (dB)		Channel	Frequency (MHz)	Peak To Average Ratio (dB)	
		QPSK	16QAM			QPSK	16QAM
23035	701.5	5.27	6.20	23060	704	5.05	6.09
23095	707.5	4.94	5.97	23095	707.5	4.85	5.92
23155	713.5	5.18	6.13	23130	711	4.99	6.02



4.7 Conducted Spurious Emissions

4.7.1 Limits of Conducted Spurious Emissions Measurement

According to FCC 27.53(g) for operations in the 600 MHz band and the 698-746 MHz band, the power of any emission outside a licensee's frequency band(s) of operation shall be attenuated below the transmitter power (P) within the licensed band(s) of operation, measured in watts, by at least $43 + 10 \log (P)$ dB. Compliance with this provision is based on the use of measurement instrumentation employing a resolution bandwidth of 100 kilohertz or greater. However, in the 100 kilohertz bands immediately outside and adjacent to a licensee's frequency block, a resolution bandwidth of at least 30 kHz may be employed.

According to FCC 27.53(h) AWS emission limits— General protection levels. Except as otherwise specified below, for operations in the 1695-1710 MHz, 1710-1755 MHz, 1755-1780 MHz, 1915-1920 MHz, 1995-2000 MHz, 2000-2020 MHz, 2110-2155 MHz, 2155-2180 MHz, and 2180-2200 bands, the power of any emission outside a licensee's frequency block shall be attenuated below the transmitter power (P) in watts by at least $43 + 10 \log_{10} (P)$ dB.

4.7.2 Test Setup

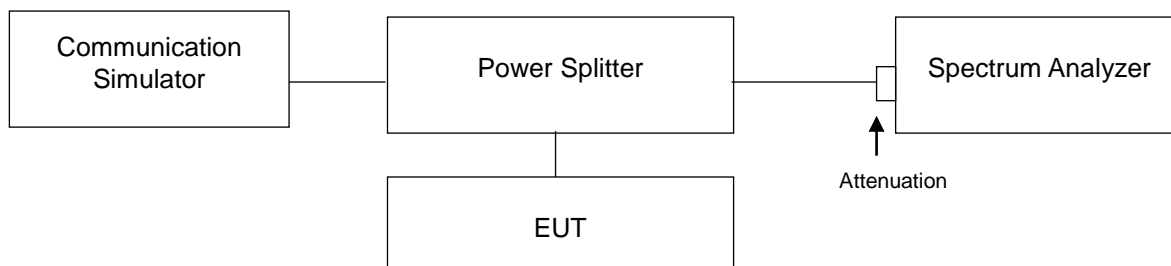

4.7.3 Test Procedure

- a. All measurements were done at 3 channels: low, middle and high operational frequency range.
- b. When the spectrum scanned from 9 kHz to the tenth harmonic of the highest fundamental frequency, it shall be connected to the 20dB pad attenuated the carried frequency.

4.7.5 Test Results

LTE Band 4

LTE Band 4 Channel Band width: 1.4MHz

Channel 19957

Frequency Range : 9kHz~1GHz

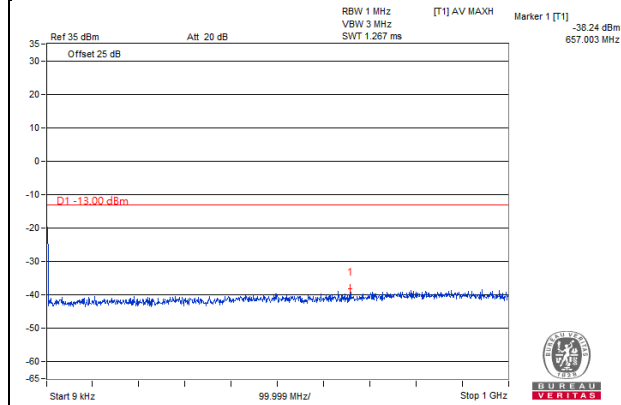

Frequency Range : 1GHz~10GHz

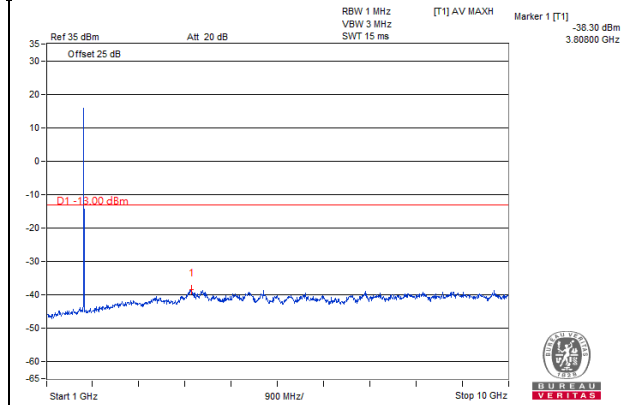

Frequency Range : 10GHz~20GHz

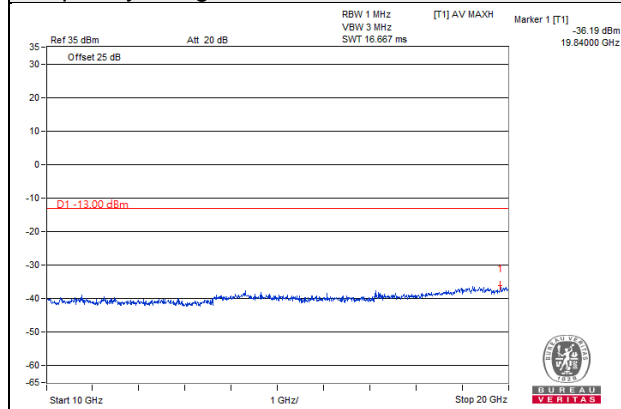

Note: The signal at 9 kHz is IF signal from spectrum analyzer.

LTE Band 4 Channel Band width: 1.4MHz

Channel 20175

Frequency Range : 9kHz~1GHz

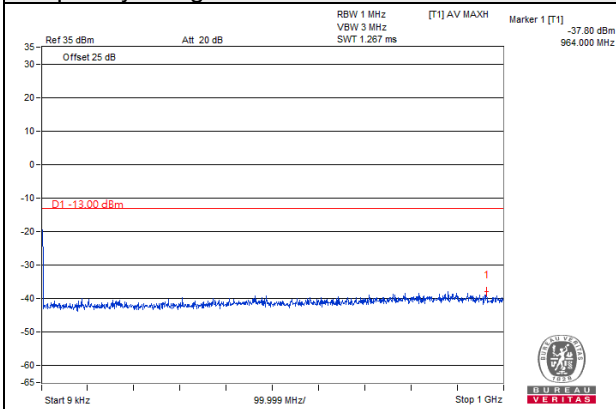

Frequency Range : 1GHz~10GHz

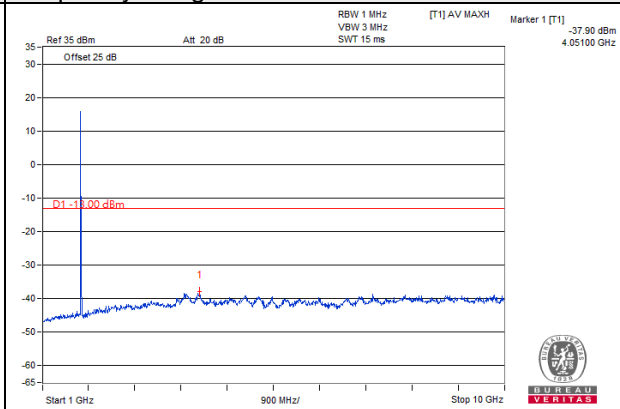

Frequency Range : 10GHz~20GHz

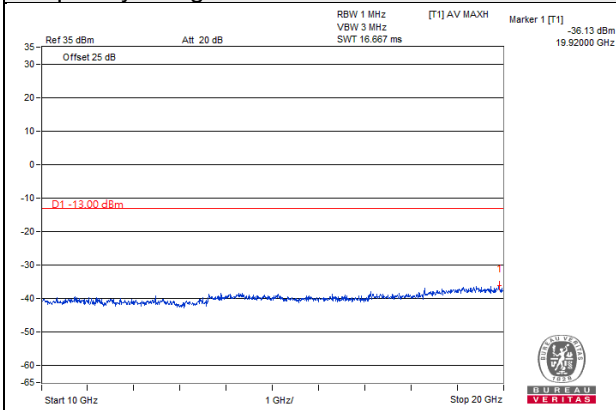

Note: The signal at 9 kHz is IF signal from spectrum analyzer.

LTE Band 4 Channel Band width: 1.4MHz

Channel 20393

Frequency Range : 9kHz~1GHz

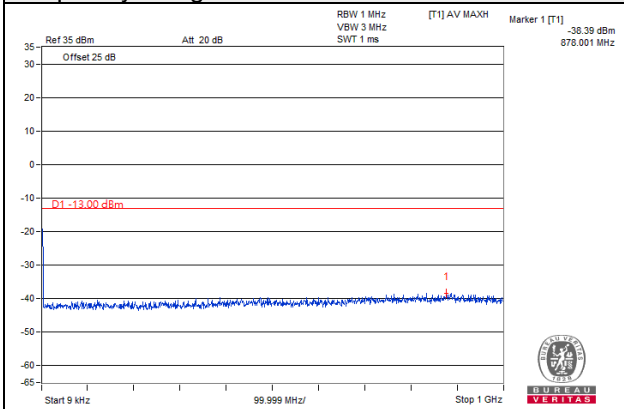

Frequency Range : 1GHz~10GHz

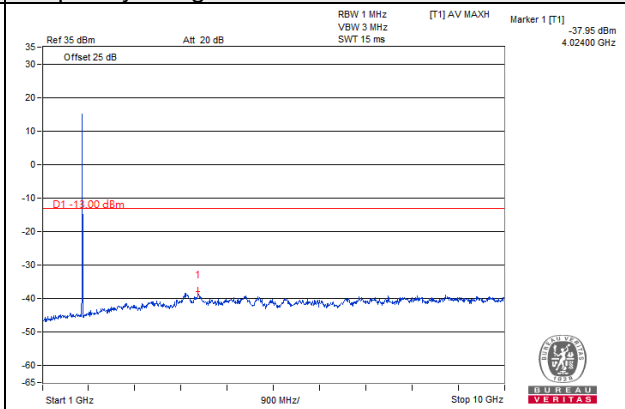

Frequency Range : 10GHz~20GHz

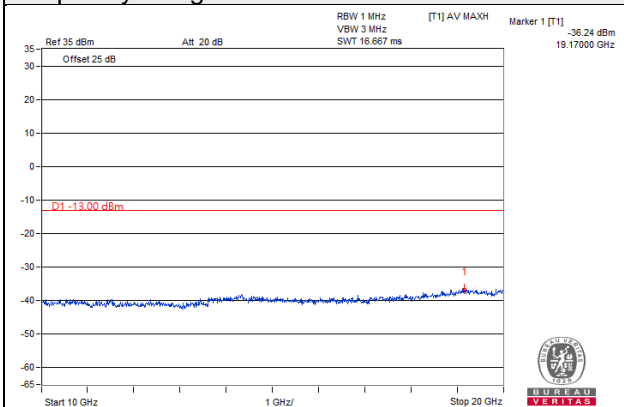

Note: The signal at 9 kHz is IF signal from spectrum analyzer.

LTE Band 4 Channel Band width: 3MHz

Channel 19965

Frequency Range : 9kHz~1GHz

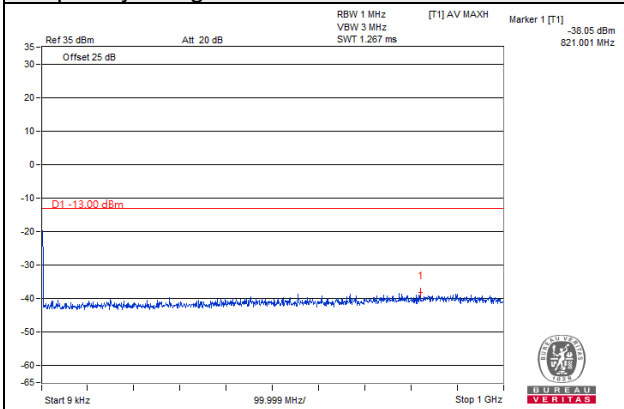

Frequency Range : 1GHz~10GHz

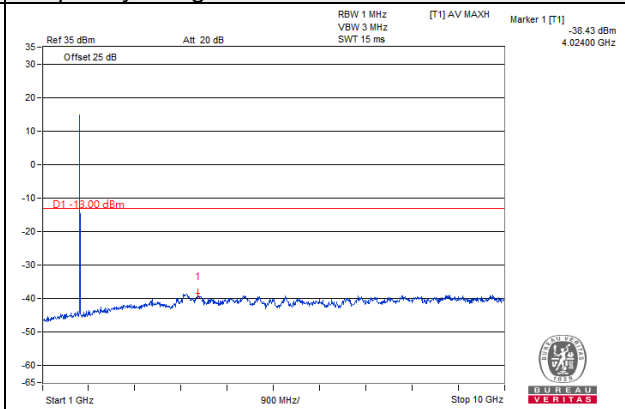

Frequency Range : 10GHz~20GHz

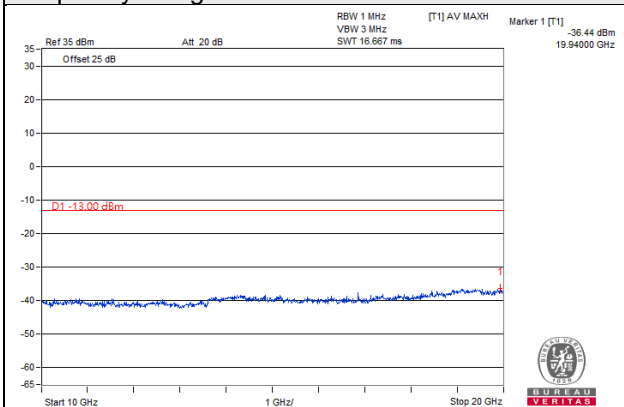

Note: The signal at 9 kHz is IF signal from spectrum analyzer.

LTE Band 4 Channel Band width: 3MHz

Channel 20175

Frequency Range : 9kHz~1GHz

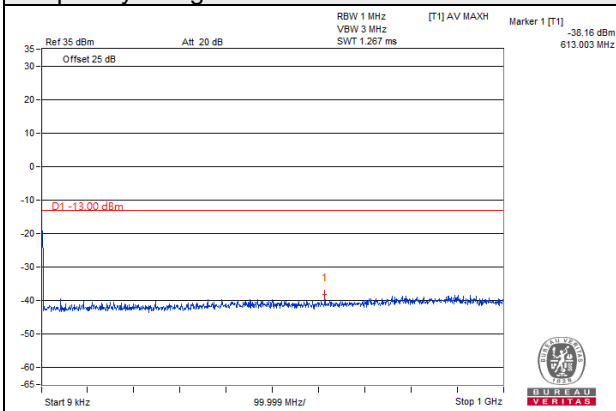

Frequency Range : 1GHz~10GHz

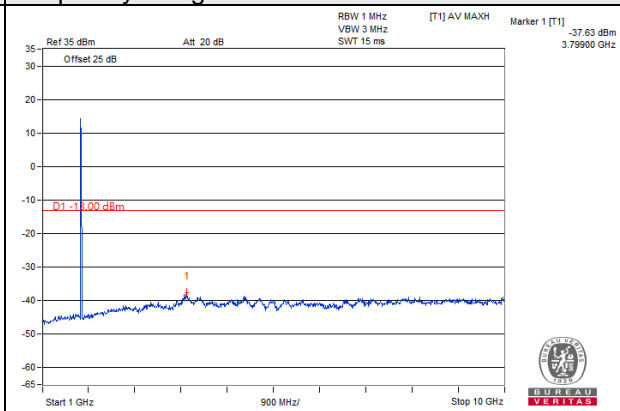

Frequency Range : 10GHz~20GHz

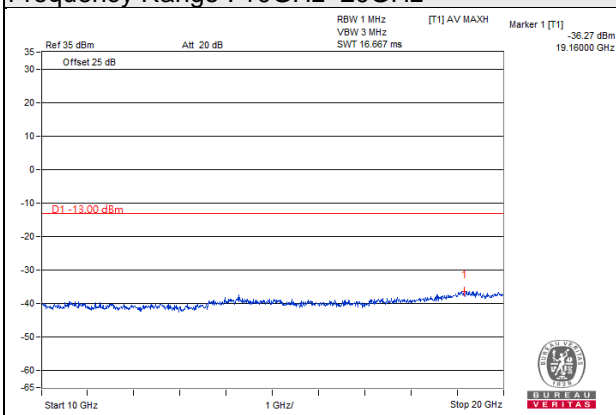

Note: The signal at 9 kHz is IF signal from spectrum analyzer.

LTE Band 4 Channel Band width: 3MHz

Channel 20385

Frequency Range : 9kHz~1GHz

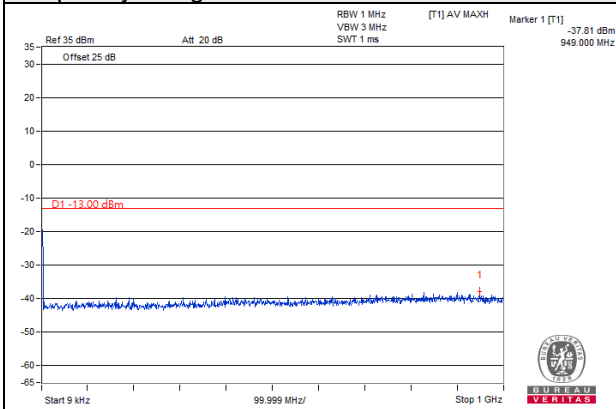

Frequency Range : 1GHz~10GHz

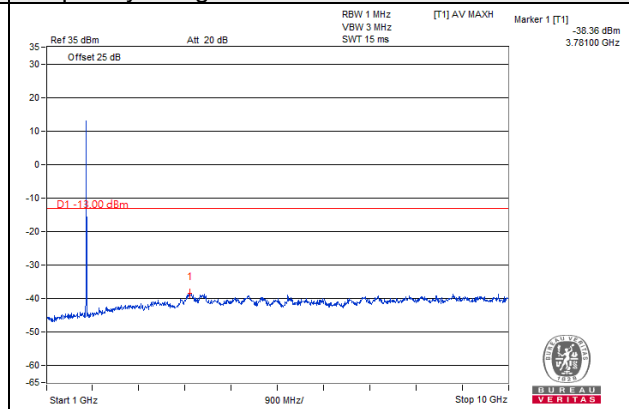

Frequency Range : 10GHz~20GHz

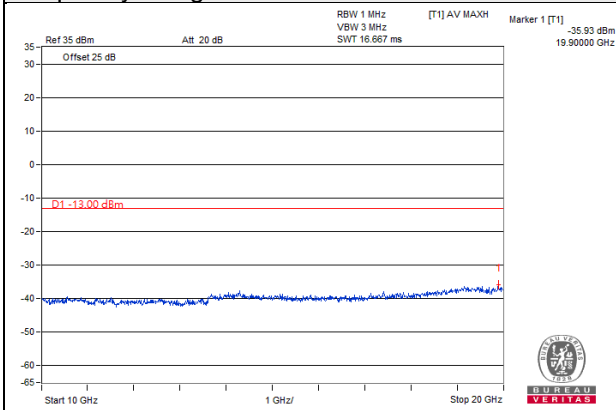

Note: The signal at 9 kHz is IF signal from spectrum analyzer.

LTE Band 4 Channel Band width: 5MHz

Channel 19975

Frequency Range : 9kHz~1GHz

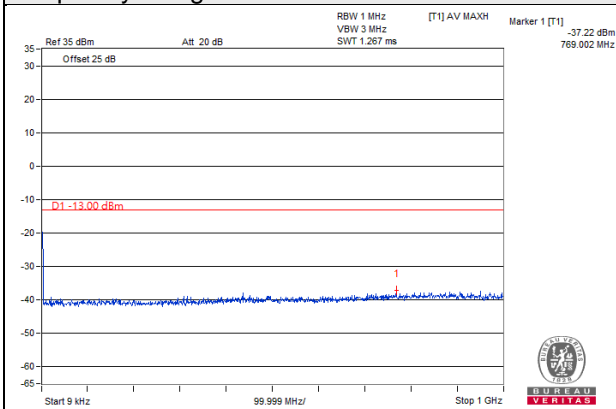

Frequency Range : 1GHz~10GHz

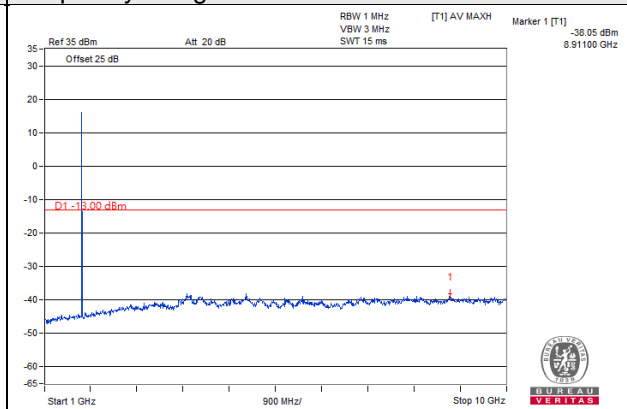

Frequency Range : 10GHz~20GHz

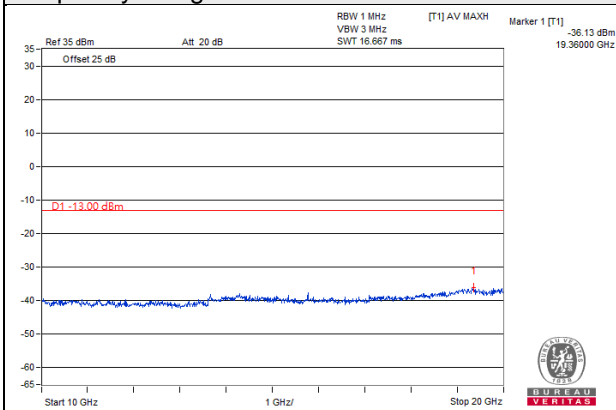

Note: The signal at 9 kHz is IF signal from spectrum analyzer.

LTE Band 4 Channel Band width: 5MHz
Channel 20175

Frequency Range : 9kHz~1GHz

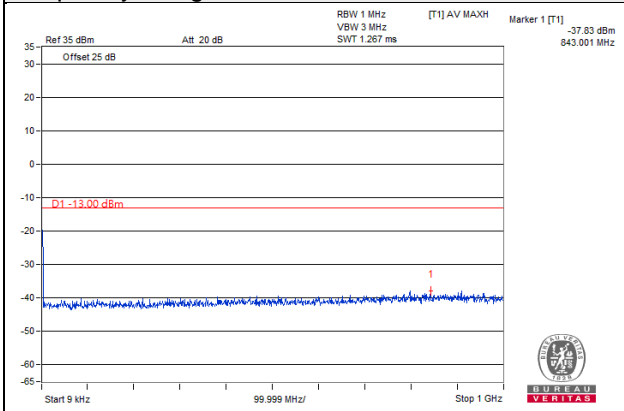

Frequency Range : 1GHz~10GHz

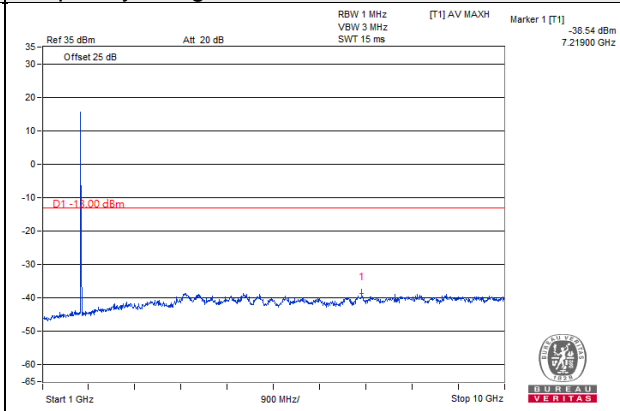

Frequency Range : 10GHz~20GHz

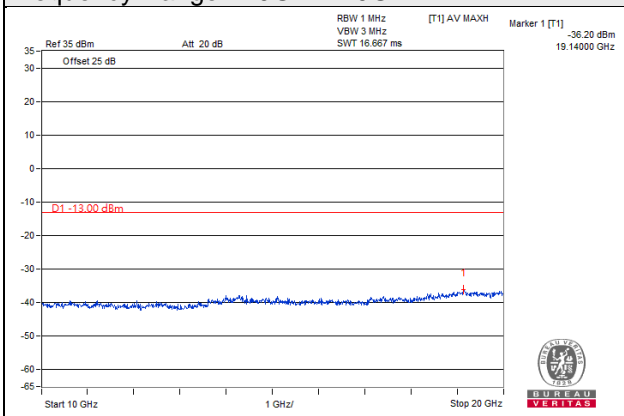

Note: The signal at 9 kHz is IF signal from spectrum analyzer.

LTE Band 4 Channel Band width: 5MHz

Channel 20375

Frequency Range : 9kHz~1GHz

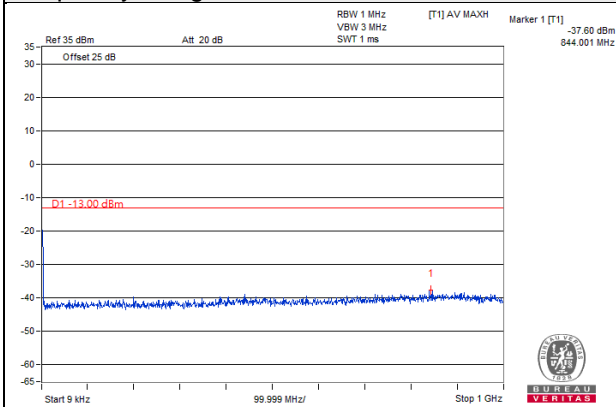

Frequency Range : 1GHz~10GHz

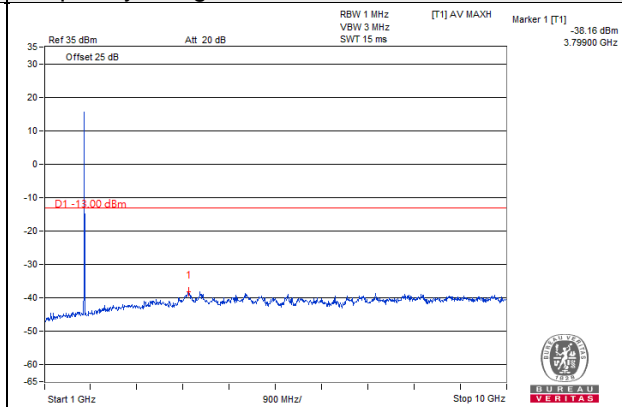

Frequency Range : 10GHz~20GHz

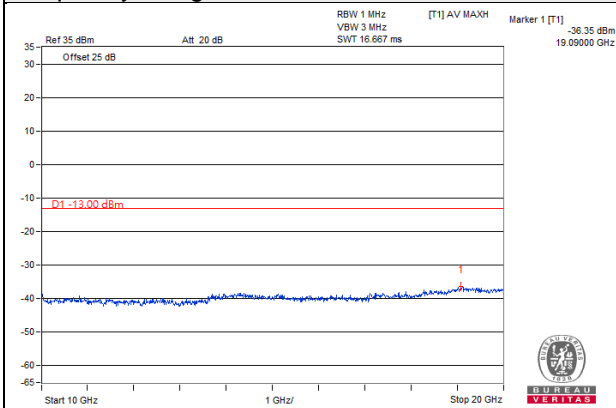

Note: The signal at 9 kHz is IF signal from spectrum analyzer.

LTE Band 4 Channel Band width: 10MHz

Channel 20000

Frequency Range : 9kHz~1GHz

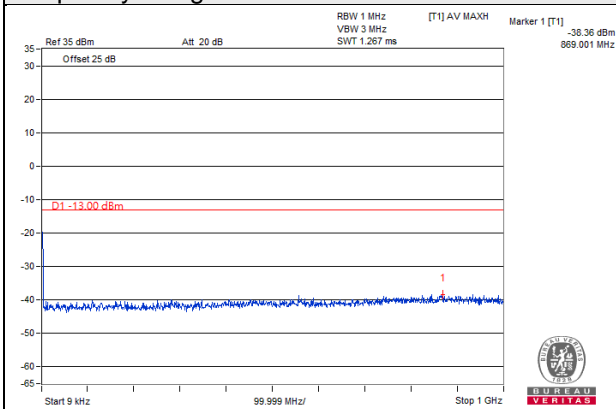

Frequency Range : 1GHz~10GHz

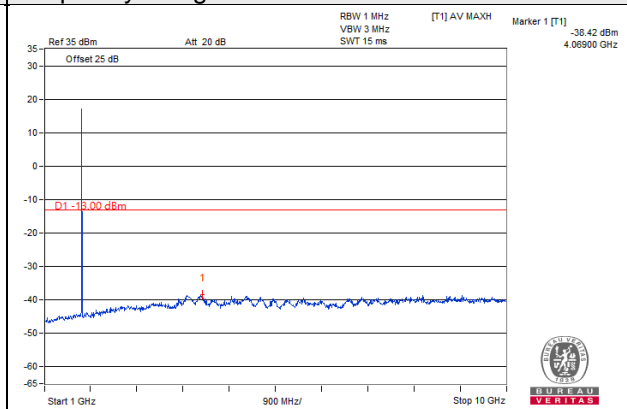

Frequency Range : 10GHz~20GHz

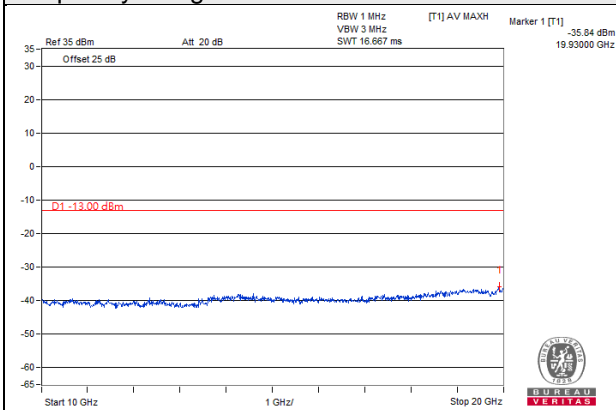

Note: The signal at 9 kHz is IF signal from spectrum analyzer.

LTE Band 4 Channel Band width: 10MHz

Channel 20175

Frequency Range : 9kHz~1GHz

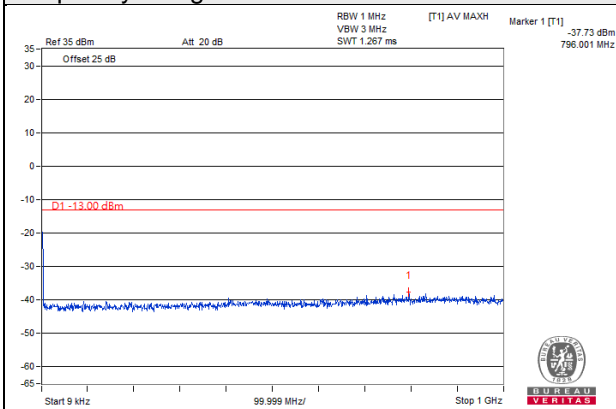

Frequency Range : 1GHz~10GHz

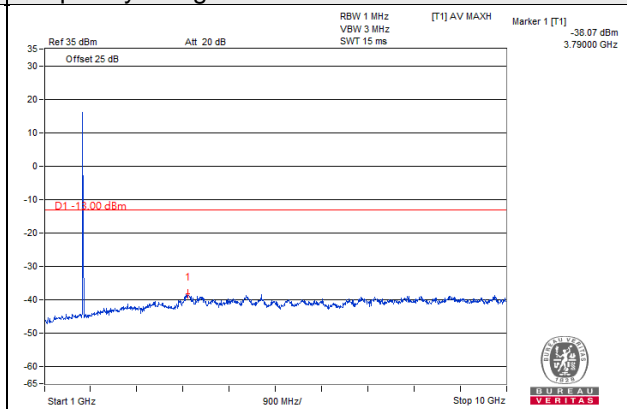

Frequency Range : 10GHz~20GHz

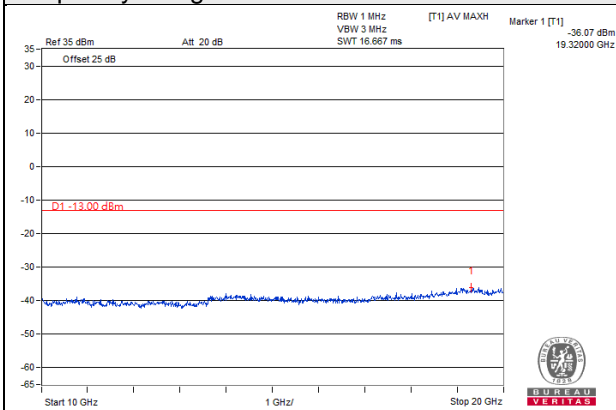

Note: The signal at 9 kHz is IF signal from spectrum analyzer.

LTE Band 4 Channel Band width: 10MHz

Channel 20350

Frequency Range : 9kHz~1GHz

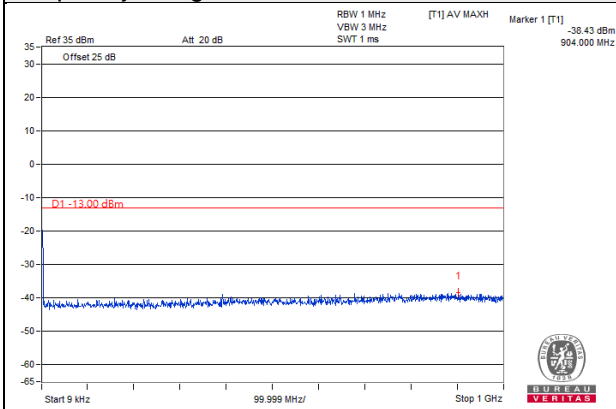

Frequency Range : 1GHz~10GHz

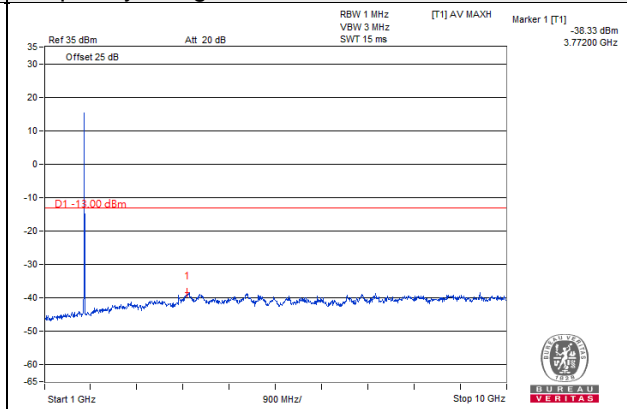

Frequency Range : 10GHz~20GHz

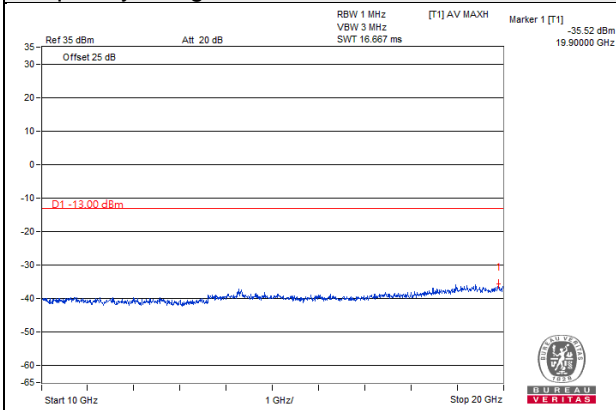

Note: The signal at 9 kHz is IF signal from spectrum analyzer.

LTE Band 4 Channel Band width: 15MHz

Channel 20025

Frequency Range : 9kHz~1GHz

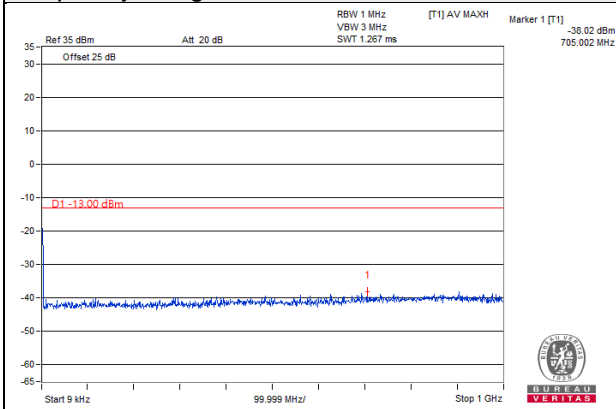

Frequency Range : 1GHz~10GHz

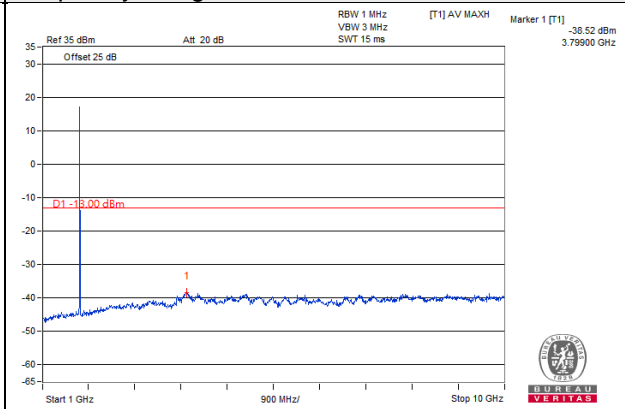

Frequency Range : 10GHz~20GHz

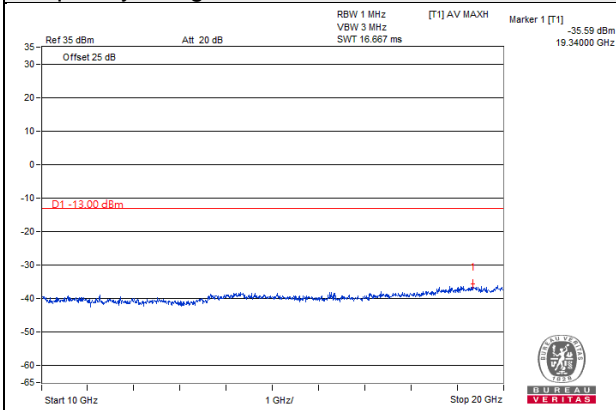

Note: The signal at 9 kHz is IF signal from spectrum analyzer.

LTE Band 4 Channel Band width: 15MHz

Channel 20175

Frequency Range : 9kHz~1GHz

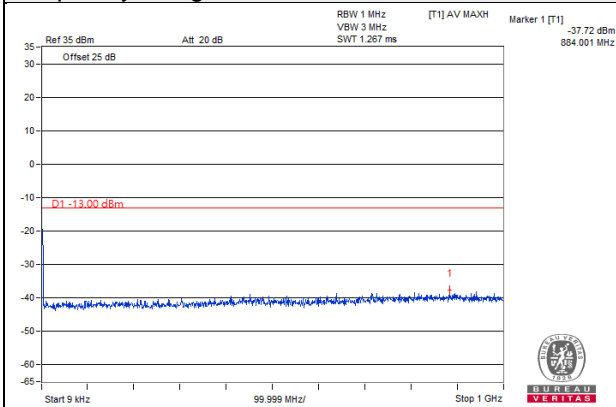

Frequency Range : 1GHz~10GHz

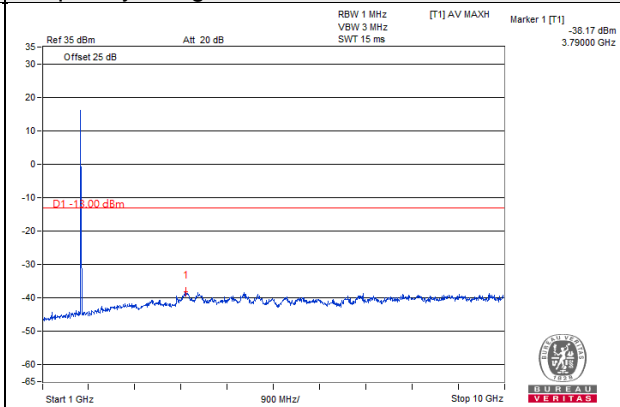

Frequency Range : 10GHz~20GHz

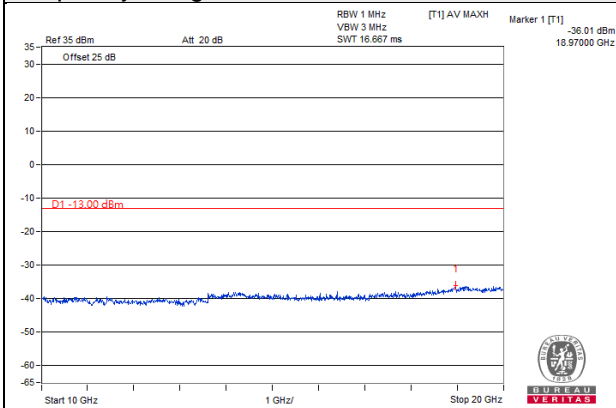

Note: The signal at 9 kHz is IF signal from spectrum analyzer.

LTE Band 4 Channel Band width: 15MHz

Channel 20325

Frequency Range : 9kHz~1GHz

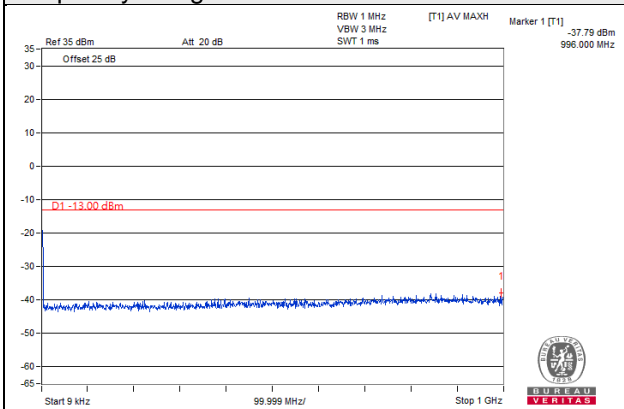

Frequency Range : 1GHz~10GHz

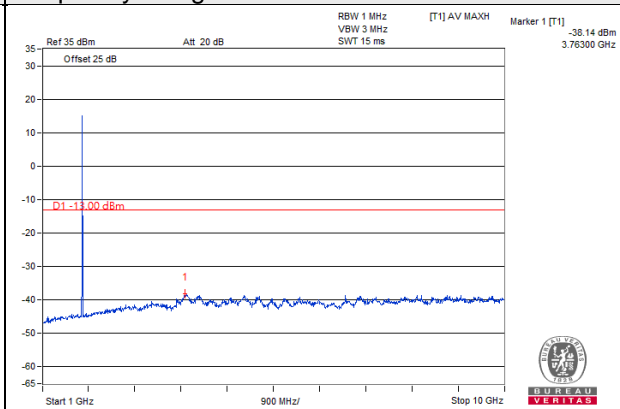

Frequency Range : 10GHz~20GHz

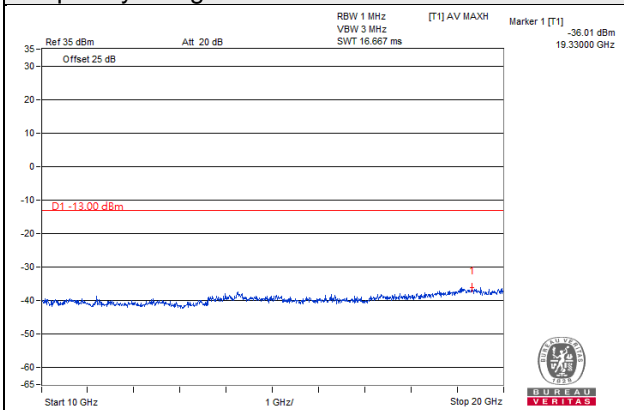

Note: The signal at 9 kHz is IF signal from spectrum analyzer.

LTE Band 4 Channel Band width: 20MHz

Channel 20050

Frequency Range : 9kHz~1GHz

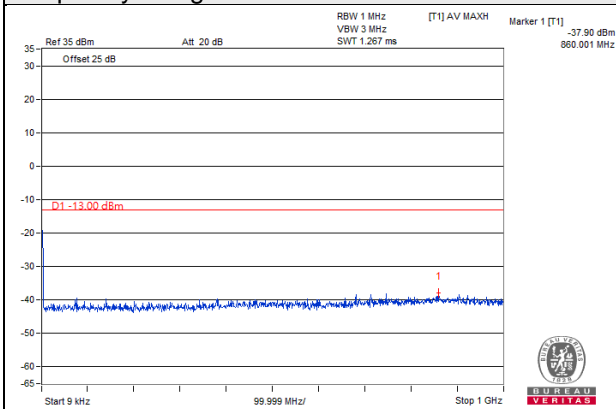

Frequency Range : 1GHz~10GHz

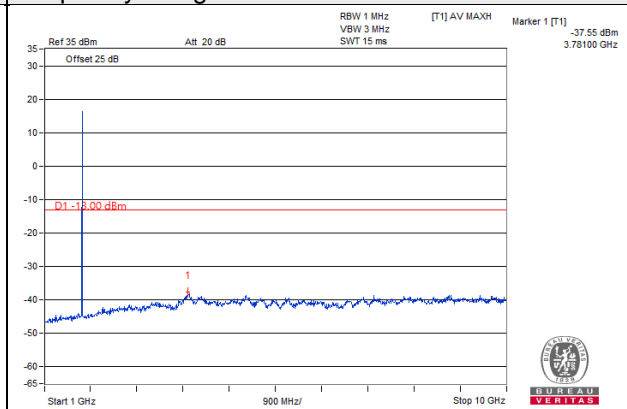

Frequency Range : 10GHz~20GHz

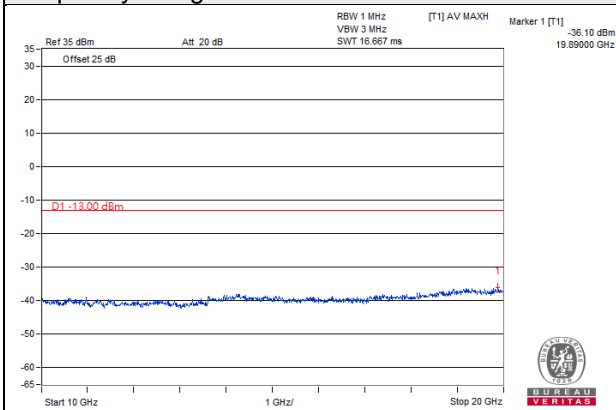

Note: The signal at 9 kHz is IF signal from spectrum analyzer.

LTE Band 4 Channel Band width: 20MHz

Channel 20175

Frequency Range : 9kHz~1GHz

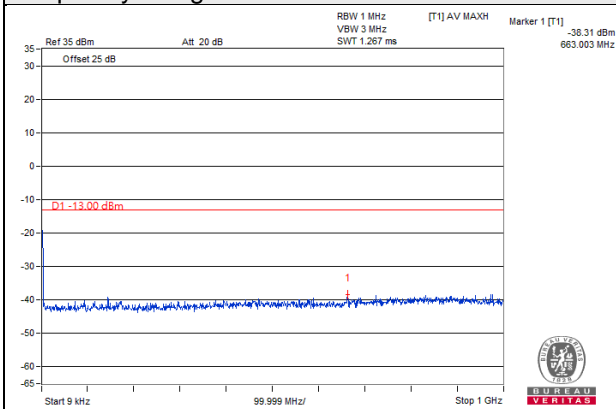

Frequency Range : 1GHz~10GHz

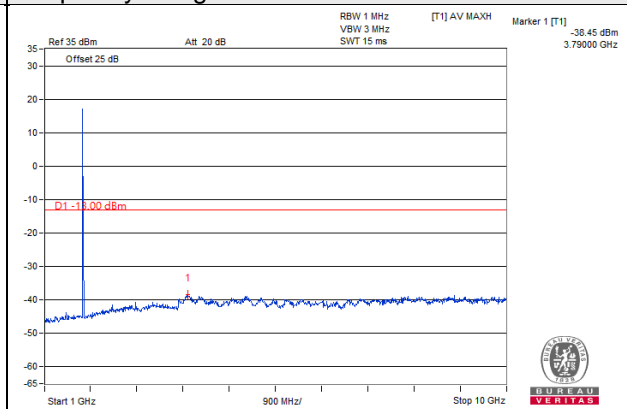

Frequency Range : 10GHz~20GHz

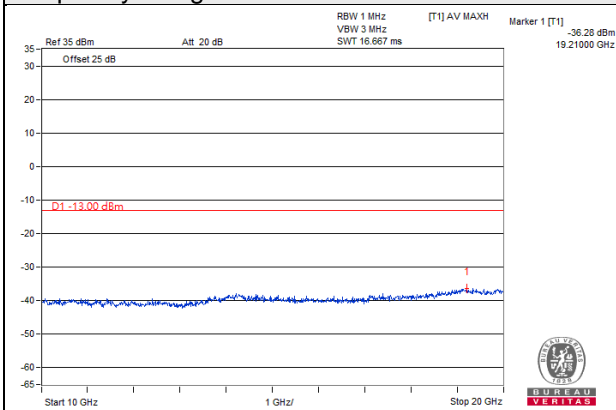

Note: The signal at 9 kHz is IF signal from spectrum analyzer.

LTE Band 4 Channel Band width: 20MHz

Channel 20300

Frequency Range : 9kHz~1GHz

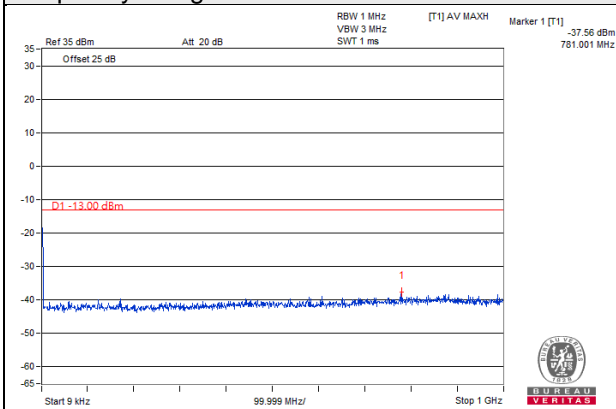

Frequency Range : 1GHz~10GHz

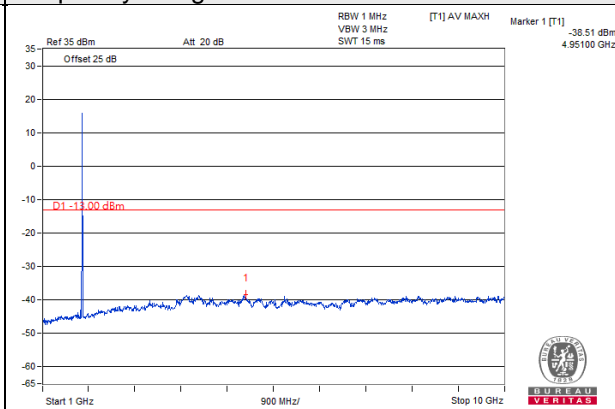

Frequency Range : 10GHz~20GHz

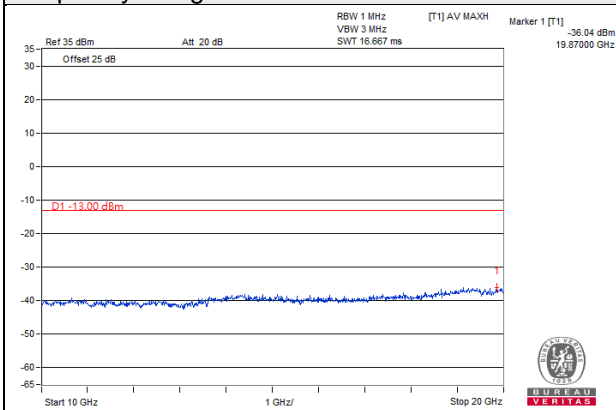

Note: The signal at 9 kHz is IF signal from spectrum analyzer.

LTE Band 12

LTE Band 12 Channel Band width: 1.4MHz

Channel 23017

Frequency Range : 9kHz~1GHz

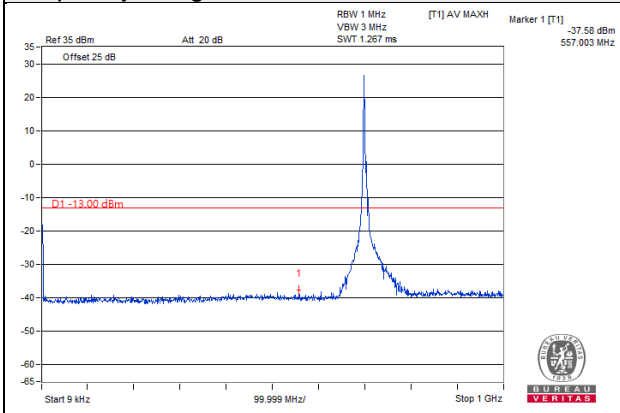

Frequency Range : 1GHz~10GHz

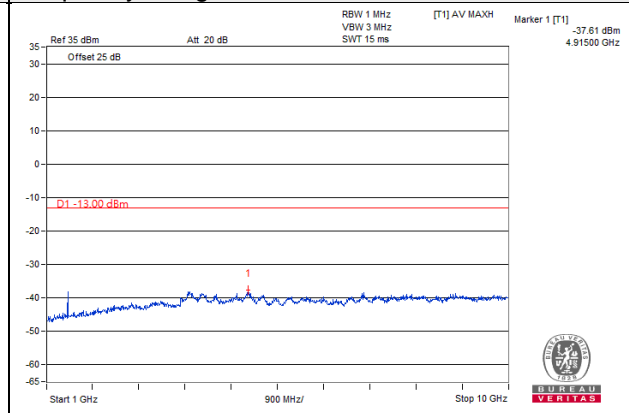

Channel 23095

Frequency Range : 9kHz~1GHz

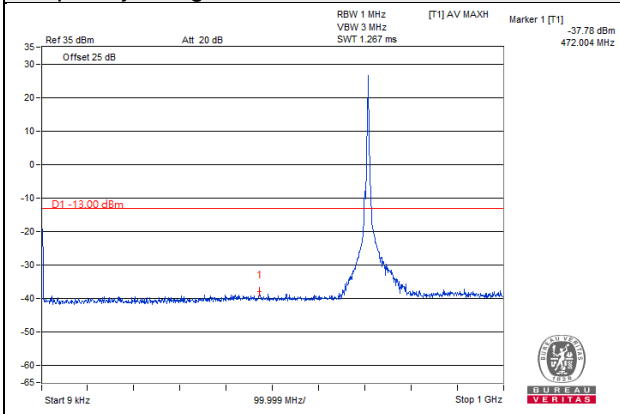

Frequency Range : 1GHz~10GHz

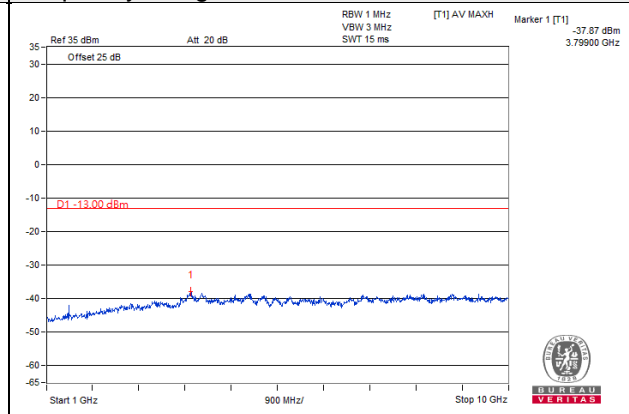

Channel 23173

Frequency Range : 9kHz~1GHz

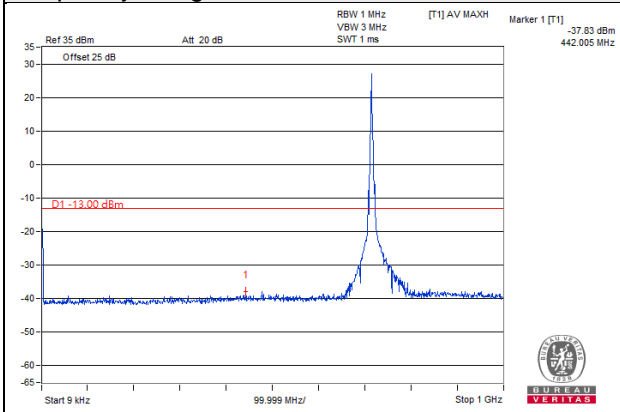

Frequency Range : 1GHz~10GHz

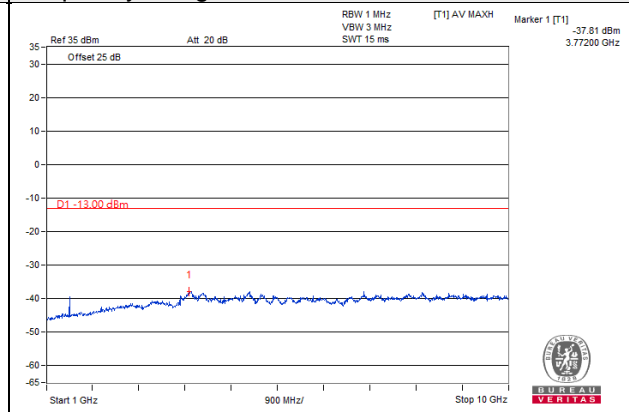

Note: The signal at 9 kHz is IF signal from spectrum analyzer.

LTE Band 12 Channel Band width: 3MHz

Channel 23025

Frequency Range : 9kHz~1GHz

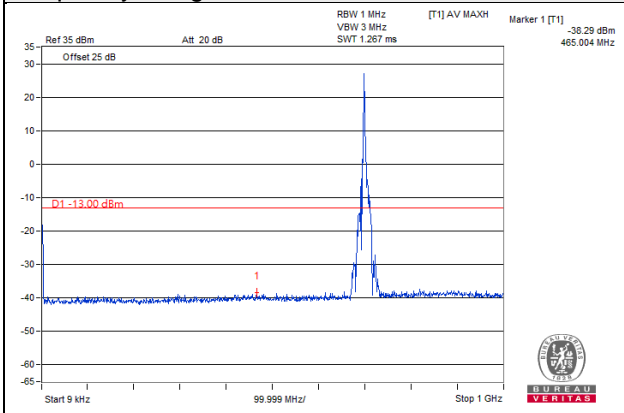

Frequency Range : 1GHz~10GHz

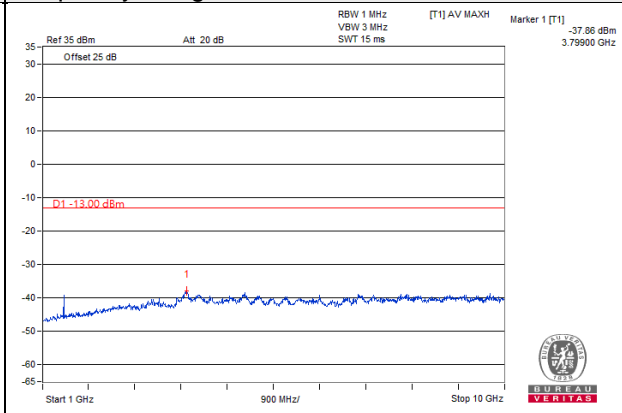

Channel 23095

Frequency Range : 9kHz~1GHz

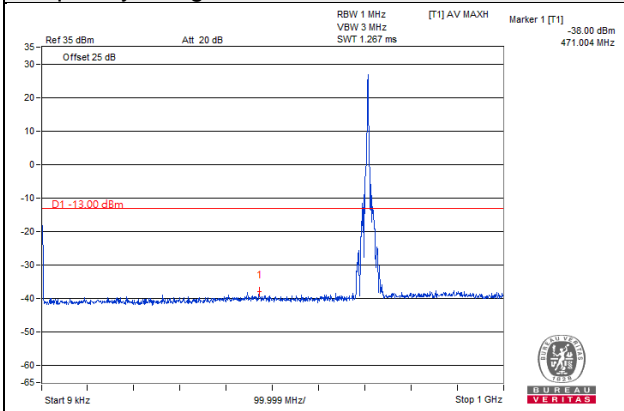

Frequency Range : 1GHz~10GHz

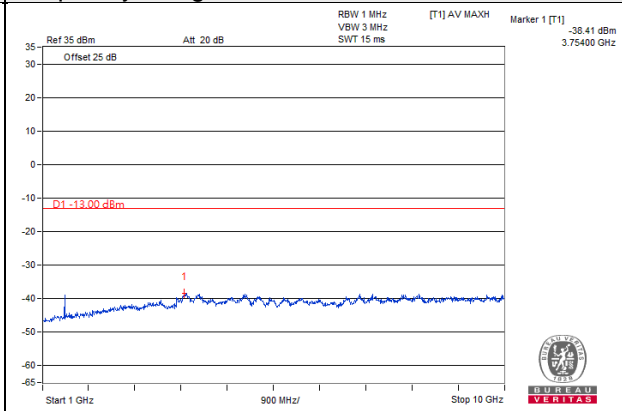

Channel 23165

Frequency Range : 9kHz~1GHz

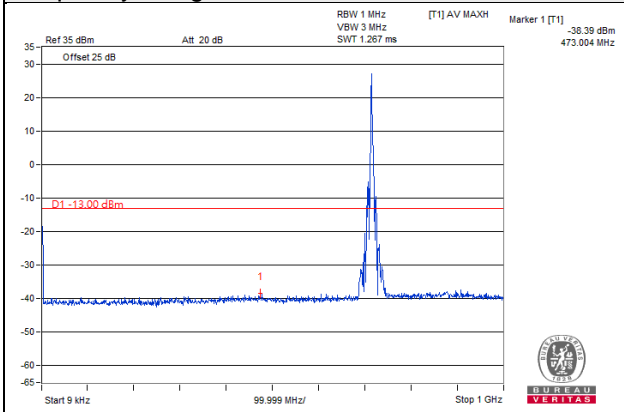

Frequency Range : 1GHz~10GHz

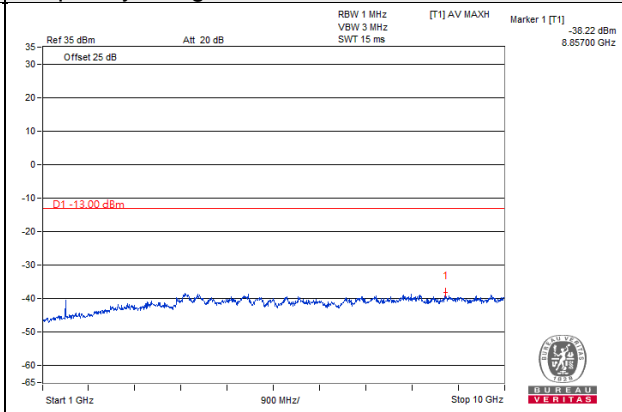

Note: The signal at 9 kHz is IF signal from spectrum analyzer.

LTE Band 12 Channel Band width: 5MHz

Channel 23035

Frequency Range : 9kHz~1GHz

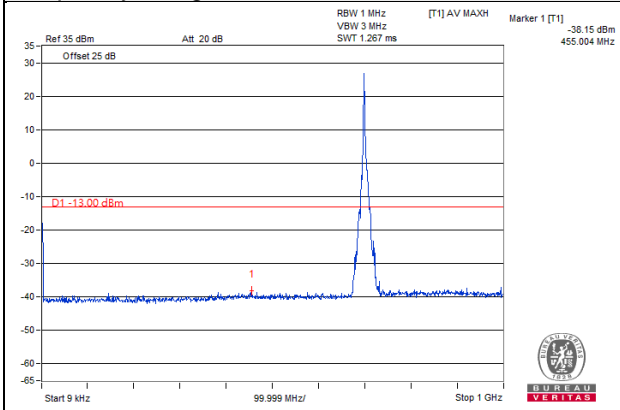

Frequency Range : 1GHz~10GHz

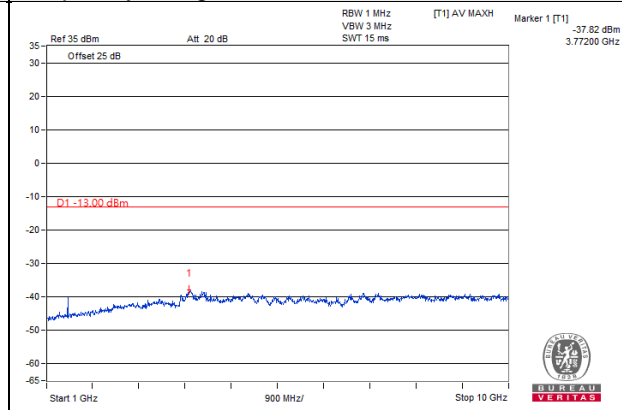

Channel 23095

Frequency Range : 9kHz~1GHz

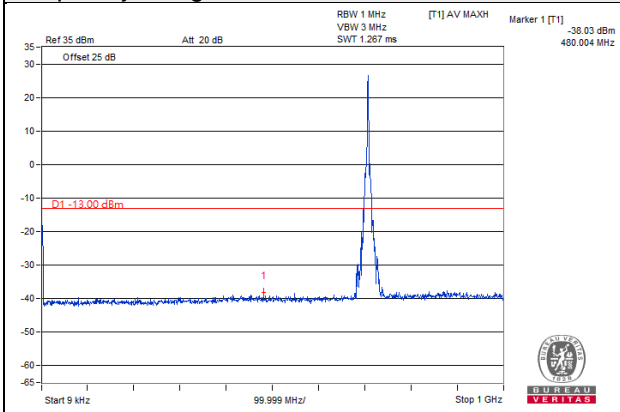

Frequency Range : 1GHz~10GHz

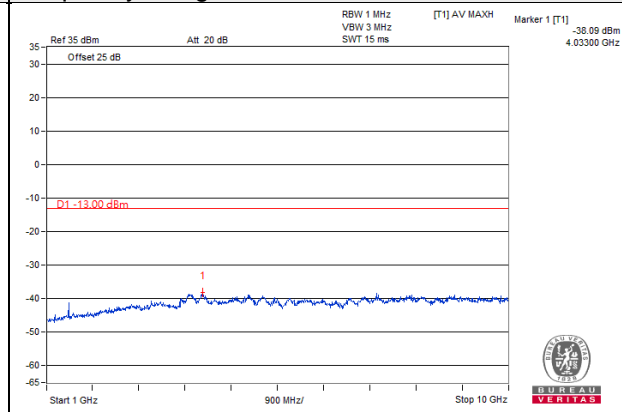

Channel 23155

Frequency Range : 9kHz~1GHz

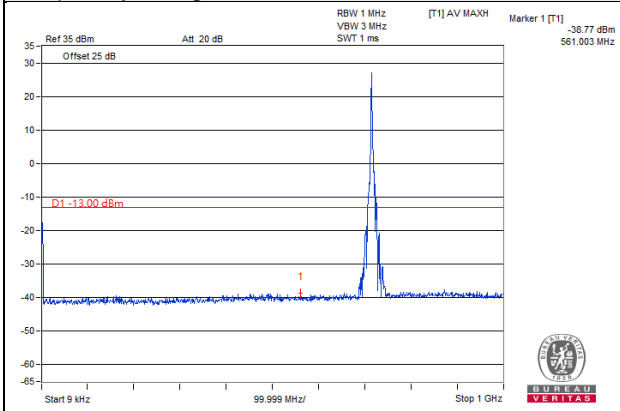

Frequency Range : 1GHz~10GHz

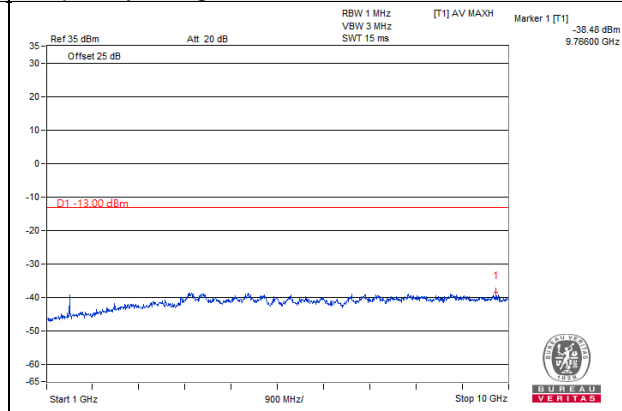

Note: The signal at 9 kHz is IF signal from spectrum analyzer.

LTE Band 12 Channel Band width: 10MHz

Channel 23060

Frequency Range : 9kHz~1GHz

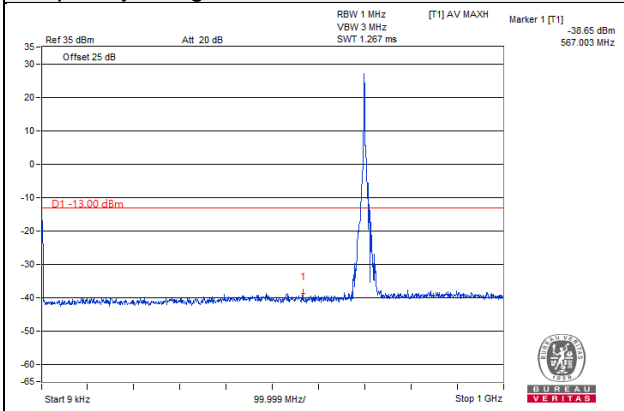

Frequency Range : 1GHz~10GHz

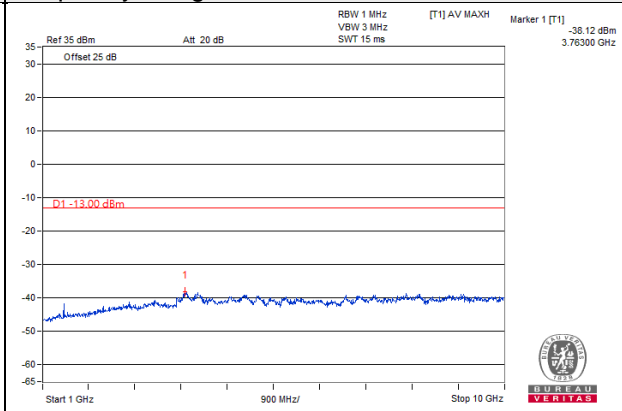

Channel 23095

Frequency Range : 9kHz~1GHz

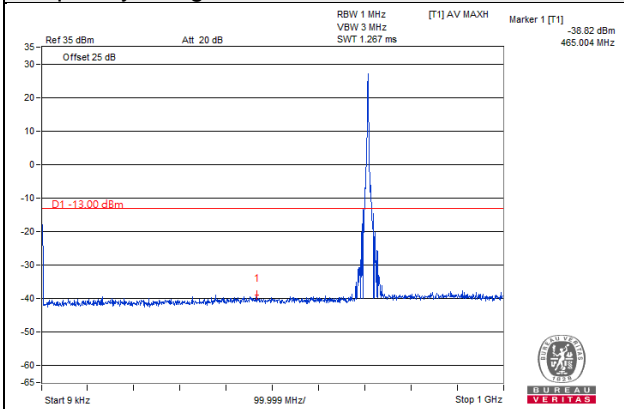

Frequency Range : 1GHz~10GHz

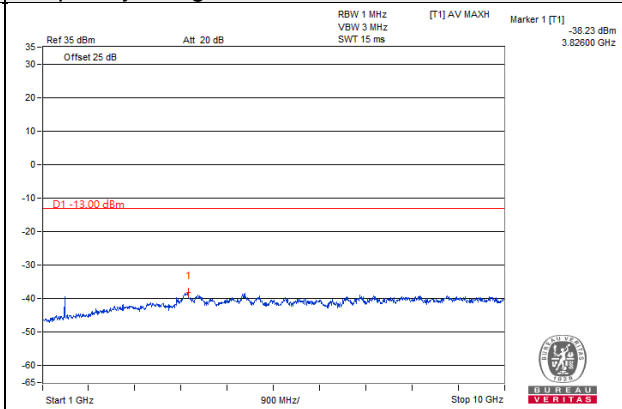

Channel 23130

Frequency Range : 9kHz~1GHz

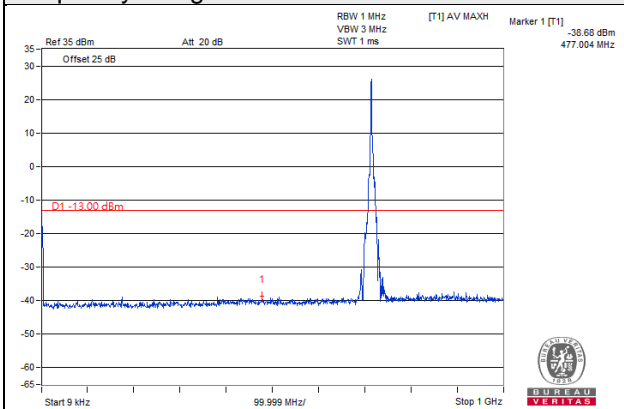

Frequency Range : 1GHz~10GHz

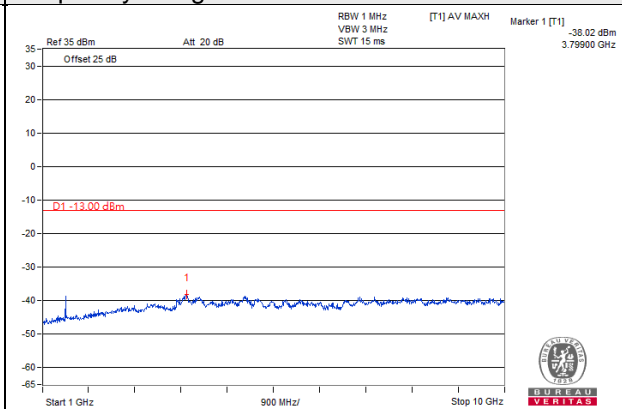

Note: The signal at 9 kHz is IF signal from spectrum analyzer.

4.8 Radiated Emission Measurement

4.8.1 Limits of Radiated Emission Measurement

According to FCC 27.53(a)(4) For mobile and portable stations operating in the 2305-2315 MHz and 2350-2360 MHz bands: (i) By a factor of not less than: $43 + 10 \log (P)$ dB on all frequencies between 2305 and 2320 MHz and on all frequencies between 2345 and 2360 MHz that are outside the licensed band(s) of operation, not less than $55 + 10 \log (P)$ dB on all frequencies between 2320 and 2324 MHz and on all frequencies between 2341 and 2345 MHz, not less than $61 + 10 \log (P)$ dB on all frequencies between 2324 and 2328 MHz and on all frequencies between 2337 and 2341 MHz, and not less than $67 + 10 \log (P)$ dB on all frequencies between 2328 and 2337 MHz; (ii) By a factor of not less than $43 + 10 \log (P)$ dB on all frequencies between 2300 and 2305 MHz, $55 + 10 \log (P)$ dB on all frequencies between 2296 and 2300 MHz, $61 + 10 \log (P)$ dB on all frequencies between 2292 and 2296 MHz, $67 + 10 \log (P)$ dB on all frequencies between 2288 and 2292 MHz, and $70 + 10 \log (P)$ dB below 2288 MHz; (iii) By a factor of not less than $43 + 10 \log (P)$ dB on all frequencies between 2360 and 2365 MHz, and not less than $70 + 10 \log (P)$ dB above 2365 MHz.

According to FCC 27.53 (c) For operations in the 746-758 MHz band and the 776-788 MHz band, the power of any emission outside the licensee's frequency band(s) of operation shall be attenuated below the transmitter power (P) within the licensed band(s) of operation, measured in watts, in accordance with the following:

- (1) On any frequency outside the 746-758 MHz band, the power of any emission shall be attenuated outside the band below the transmitter power (P) by at least $43 + 10 \log (P)$ dB;
- (2) On any frequency outside the 776-788 MHz band, the power of any emission shall be attenuated outside the band below the transmitter power (P) by at least $43 + 10 \log (P)$ dB;
- (3) On all frequencies between 763-775 MHz and 793-805 MHz, by a factor not less than $76 + 10 \log (P)$ dB in a 6.25 kHz band segment, for base and fixed stations;
- (4) On all frequencies between 763-775 MHz and 793-805 MHz, by a factor not less than $65 + 10 \log (P)$ dB in a 6.25 kHz band segment, for mobile and portable stations;
- (5) Compliance with the provisions of paragraphs (c)(1) and (c)(2) of this section is based on the use of measurement instrumentation employing a resolution bandwidth of 100 kHz or greater. However, in the 100 kHz bands immediately outside and adjacent to the frequency block, a resolution bandwidth of at least 30 kHz may be employed;
- (6) Compliance with the provisions of paragraphs (c)(3) and (c)(4) of this section is based on the use of measurement instrumentation such that the reading taken with any resolution bandwidth setting should be adjusted to indicate spectral energy in a 6.25 kHz segment.

According to FCC 27.53(f) For operations in the 746–758 MHz, 775–788 MHz, and 805–806 MHz bands, emissions in the band 1559–1610 MHz shall be limited to -70 dBW/MHz equivalent isotropically radiated power (EIRP) for wideband signals, and -80 dBW EIRP for discrete emissions of less than 700 Hz bandwidth.

According to FCC 27.53(g) For operations in the 600 MHz band and the 698-746 MHz band, the power of any emission outside a licensee's frequency band(s) of operation shall be attenuated below the transmitter power (P) within the licensed band(s) of operation, measured in watts, by at least $43 + 10 \log (P)$ dB. Compliance with this provision is based on the use of measurement instrumentation employing a resolution bandwidth of 100 kilohertz or greater. However, in the 100 kilohertz bands immediately outside and adjacent to a licensee's frequency block, a resolution bandwidth of at least 30 kHz may be employed.

According to FCC 27.53(h) AWS emission limits— General protection levels. Except as otherwise specified below, for operations in the 1695-1710 MHz, 1710-1755 MHz, 1755-1780 MHz, 1915-1920 MHz, 1995-2000 MHz, 2000-2020 MHz, 2110-2155 MHz, 2155-2180 MHz, and 2180-2200 bands, the power of any emission outside a licensee's frequency block shall be attenuated below the transmitter power (P) in watts by at least $43 + 10 \log_{10} (P)$ dB.

According to FCC 27.53(v)(4) For mobile digital stations, the attenuation factor shall be not less than $40 + 10 \log (P)$ dB on all frequencies between the channel edge and 5 megahertz from the channel edge, $43 + 10 \log (P)$ dB on all frequencies between 5 megahertz and X megahertz from the channel edge, and $55 + 10 \log (P)$ dB on all frequencies more than X megahertz from the channel edge, where X is the greater of 6 megahertz or the actual emission bandwidth as defined in paragraph (m)(6) of this section. In addition, the attenuation factor shall not be less than $43 + 10 \log (P)$ dB on all frequencies between 2490.5 MHz and 2496 MHz and $55 + 10 \log (P)$ dB at or below 2490.5 MHz. Mobile Satellite Service licensees operating on frequencies below 2495 MHz may also submit a documented interference complaint against BRS licensees operating on channel BRS Channel 1 on the same terms and conditions as adjacent channel BRS or EBS licensees.

4.8.2 Test Procedure

- a. The power was measured with Spectrum Analyzer. All measurements were done at 3 channels (low, middle and high channel of operational frequency range.)
- b. Substitution method is used for EIRP measurement. In the semi-anechoic chamber, EUT placed on the 0.8m/1.5m height of Turn Table, rotated the table around 360 degrees to search the maximum radiation power and receiver antenna shall be rotated vertical and horizontal polarization and moved height from 1m to 4m to find the maximum polar radiated power. The "Read Value" is the spectrum reading the maximum power value.
- c. The substitution antenna is substituted for EUT at the same position and signals generator export the CW signal to the substitution antenna via a TX cable. Rotated the Turn Table and moved receiving antenna to find the maximum radiation power. Adjust output power level of S.G to get a Value of spectrum reading equal to "Read Value " of step b. Record the power level of S.G
- d. $EIRP = \text{Output power level of S.G} - \text{TX cable loss} + \text{Antenna gain of substitution antenna.}$

NOTE: The resolution bandwidth and video bandwidth of test receiver/spectrum analyzer is 1MHz/3MHz.

4.8.3 Deviation from Test Standard

No deviation.

4.8.4 Test Setup

<Frequency Range below 1GHz>

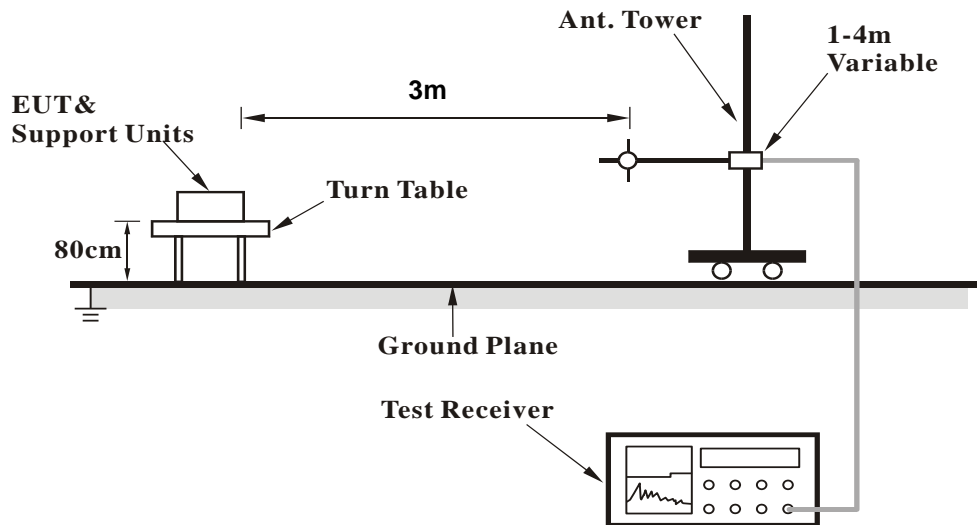

<Frequency Range above 1GHz>

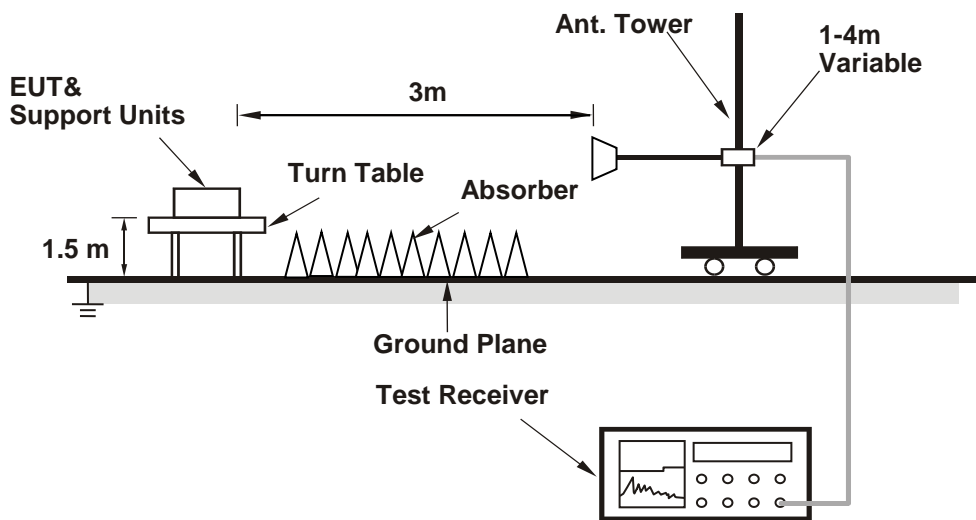

For the actual test configuration, please refer to the attached file (Test Setup Photo).

4.8.5 Test Results

Below 1GHz

LTE Band 4: 1.4MHz

Mode	TX channel 19957	Frequency Range	Below 1000 MHz
------	------------------	-----------------	----------------

Antenna Polarity & Test Distance: Horizontal at 3 M							
No.	Freq. (MHz)	Reading (dBm)	S.G Power Value (dBm)	Correction Factor (dB)	Emission Value (dBm)	Limit (dBm)	Margin (dB)
1	75.5	30.55	-64.33	-2.04	-66.37	-13	-53.37
2	127.8	29.90	-61.39	-1.23	-62.62	-13	-49.62
3	277.44	29.67	-65.43	3.86	-61.57	-13	-48.57
4	346.02	26.38	-71.32	3.60	-67.71	-13	-54.71
5	522.4	29.90	-65.35	2.72	-62.63	-13	-49.63
6	623.12	22.90	-71.89	1.77	-70.12	-13	-57.12
Antenna Polarity & Test Distance: Vertical at 3 M							
No.	Freq. (MHz)	Reading (dBm)	S.G Power Value (dBm)	Correction Factor (dB)	Emission Value (dBm)	Limit (dBm)	Margin (dB)
1	69.45	28.07	-59.72	-4.84	-64.55	-13	-51.55
2	90.93	29.85	-62.38	-1.15	-63.53	-13	-50.53
3	128.47	30.74	-60.70	-1.24	-61.93	-13	-48.93
4	217.7	27.33	-68.10	4.11	-63.99	-13	-50.99
5	522.35	31.39	-63.87	2.72	-61.14	-13	-48.14
6	624.26	35.67	-59.13	1.77	-57.36	-13	-44.36

Remarks:

1. Emission Value (dBm) = S.G Value (dBm) + Correction Factor (dB).
2. Correction Factor (dB) = Substitution Antenna Gain (dB) + Cable Loss (dB).

Mode	TX channel 20175	Frequency Range	Below 1000 MHz
------	------------------	-----------------	----------------

Antenna Polarity & Test Distance: Horizontal at 3 M

No.	Freq. (MHz)	Reading (dBm)	S.G Power Value (dBm)	Correction Factor (dB)	Emission Value (dBm)	Limit (dBm)	Margin (dB)
1	75.77	30.54	-64.30	-2.02	-66.32	-13	-53.32
2	127.52	29.80	-61.43	-1.23	-62.66	-13	-49.66
3	277.54	28.98	-66.12	3.86	-62.26	-13	-49.26
4	346.16	26.31	-71.40	3.60	-67.79	-13	-54.79
5	522.41	30.12	-65.13	2.72	-62.41	-13	-49.41
6	622.04	22.98	-71.81	1.77	-70.04	-13	-57.04

Antenna Polarity & Test Distance: Vertical at 3 M

No.	Freq. (MHz)	Reading (dBm)	S.G Power Value (dBm)	Correction Factor (dB)	Emission Value (dBm)	Limit (dBm)	Margin (dB)
1	68.83	26.95	-60.47	-5.02	-65.48	-13	-52.48
2	91.4	29.61	-62.54	-1.12	-63.66	-13	-50.66
3	128.32	30.57	-60.83	-1.24	-62.07	-13	-49.07
4	218.6	26.01	-69.42	4.10	-65.32	-13	-52.32
5	521.6	31.03	-64.23	2.73	-61.50	-13	-48.50
6	623.73	34.76	-60.04	1.77	-58.27	-13	-45.27

Remarks:

1. Emission Value (dBm) = S.G Value (dBm) + Correction Factor (dB).
2. Correction Factor (dB) = Substitution Antenna Gain (dB) + Cable Loss (dB).

Mode	TX channel 20393	Frequency Range	Below 1000 MHz
------	------------------	-----------------	----------------

Antenna Polarity & Test Distance: Horizontal at 3 M

No.	Freq. (MHz)	Reading (dBm)	S.G Power Value (dBm)	Correction Factor (dB)	Emission Value (dBm)	Limit (dBm)	Margin (dB)
1	75.11	30.12	-64.83	-2.06	-66.89	-13	-53.89
2	127.82	29.87	-61.43	-1.23	-62.66	-13	-49.66
3	277.65	30.04	-65.07	3.86	-61.21	-13	-48.21
4	346.89	26.41	-71.33	3.60	-67.72	-13	-54.72
5	522.13	29.88	-65.38	2.73	-62.65	-13	-49.65
6	623.46	23.82	-70.98	1.77	-69.21	-13	-56.21

Antenna Polarity & Test Distance: Vertical at 3 M

No.	Freq. (MHz)	Reading (dBm)	S.G Power Value (dBm)	Correction Factor (dB)	Emission Value (dBm)	Limit (dBm)	Margin (dB)
1	68.56	27.30	-59.95	-5.10	-65.05	-13	-52.05
2	90.95	28.68	-63.55	-1.15	-64.70	-13	-51.70
3	127.55	29.54	-61.70	-1.23	-62.93	-13	-49.93
4	217.76	25.97	-69.46	4.11	-65.35	-13	-52.35
5	522.62	30.15	-65.10	2.72	-62.38	-13	-49.38
6	623.75	34.99	-59.81	1.77	-58.04	-13	-45.04

Remarks:

1. Emission Value (dBm) = S.G Value (dBm) + Correction Factor (dB).
2. Correction Factor (dB) = Substitution Antenna Gain (dB) + Cable Loss (dB).

LTE Band 4: 3MHz

Mode	TX channel 19965	Frequency Range	Below 1000 MHz
------	------------------	-----------------	----------------

Antenna Polarity & Test Distance: Horizontal at 3 M

No.	Freq. (MHz)	Reading (dBm)	S.G Power Value (dBm)	Correction Factor (dB)	Emission Value (dBm)	Limit (dBm)	Margin (dB)
1	76.32	29.87	-64.87	-1.99	-66.86	-13	-53.86
2	127.85	29.77	-61.53	-1.23	-62.76	-13	-49.76
3	279.33	29.98	-65.18	3.85	-61.33	-13	-48.33
4	347.09	27.52	-70.22	3.60	-66.62	-13	-53.62
5	521.61	29.97	-65.29	2.73	-62.56	-13	-49.56
6	622.8	23.65	-71.14	1.77	-69.37	-13	-56.37

Antenna Polarity & Test Distance: Vertical at 3 M

No.	Freq. (MHz)	Reading (dBm)	S.G Power Value (dBm)	Correction Factor (dB)	Emission Value (dBm)	Limit (dBm)	Margin (dB)
1	70.27	27.60	-60.68	-4.60	-65.28	-13	-52.28
2	90.93	29.79	-62.44	-1.15	-63.59	-13	-50.59
3	128.89	30.30	-61.23	-1.24	-62.47	-13	-49.47
4	217.66	25.91	-69.52	4.11	-65.41	-13	-52.41
5	522.19	30.52	-64.74	2.72	-62.01	-13	-49.01
6	624.34	34.71	-60.09	1.77	-58.32	-13	-45.32

Remarks:

1. Emission Value (dBm) = S.G Value (dBm) + Correction Factor (dB).
2. Correction Factor (dB) = Substitution Antenna Gain (dB) + Cable Loss (dB).

Mode	TX channel 20175	Frequency Range	Below 1000 MHz
------	------------------	-----------------	----------------

Antenna Polarity & Test Distance: Horizontal at 3 M

No.	Freq. (MHz)	Reading (dBm)	S.G Power Value (dBm)	Correction Factor (dB)	Emission Value (dBm)	Limit (dBm)	Margin (dB)
1	75.47	29.30	-65.59	-2.04	-67.63	-13	-54.63
2	128.21	29.50	-61.88	-1.24	-63.11	-13	-50.11
3	278.54	30.15	-64.98	3.85	-61.13	-13	-48.13
4	346.76	27.41	-70.32	3.60	-66.72	-13	-53.72
5	522.14	30.19	-65.07	2.73	-62.34	-13	-49.34
6	622.95	23.93	-70.86	1.77	-69.09	-13	-56.09

Antenna Polarity & Test Distance: Vertical at 3 M

No.	Freq. (MHz)	Reading (dBm)	S.G Power Value (dBm)	Correction Factor (dB)	Emission Value (dBm)	Limit (dBm)	Margin (dB)
1	69.11	27.93	-59.65	-4.94	-64.59	-13	-51.59
2	91.89	29.55	-62.52	-1.09	-63.61	-13	-50.61
3	128.91	29.87	-61.66	-1.24	-62.90	-13	-49.90
4	218.37	27.19	-68.24	4.10	-64.14	-13	-51.14
5	522.48	31.06	-64.19	2.72	-61.47	-13	-48.47
6	625.19	35.54	-59.27	1.77	-57.50	-13	-44.50

Remarks:

1. Emission Value (dBm) = S.G Value (dBm) + Correction Factor (dB).
2. Correction Factor (dB) = Substitution Antenna Gain (dB) + Cable Loss (dB).

Mode	TX channel 20385	Frequency Range	Below 1000 MHz
------	------------------	-----------------	----------------

Antenna Polarity & Test Distance: Horizontal at 3 M

No.	Freq. (MHz)	Reading (dBm)	S.G Power Value (dBm)	Correction Factor (dB)	Emission Value (dBm)	Limit (dBm)	Margin (dB)
1	74.91	29.41	-65.58	-2.07	-67.65	-13	-54.65
2	128.25	30.03	-61.36	-1.24	-62.59	-13	-49.59
3	277.94	29.49	-65.63	3.86	-61.77	-13	-48.77
4	346.23	27.10	-70.61	3.60	-67.00	-13	-54.00
5	522.03	29.89	-65.37	2.73	-62.64	-13	-49.64
6	623.77	24.18	-70.62	1.77	-68.85	-13	-55.85

Antenna Polarity & Test Distance: Vertical at 3 M

No.	Freq. (MHz)	Reading (dBm)	S.G Power Value (dBm)	Correction Factor (dB)	Emission Value (dBm)	Limit (dBm)	Margin (dB)
1	70.13	27.70	-60.49	-4.64	-65.14	-13	-52.14
2	90.87	29.10	-63.14	-1.15	-64.30	-13	-51.30
3	128.29	30.28	-61.12	-1.24	-62.35	-13	-49.35
4	216.88	26.64	-68.79	4.12	-64.67	-13	-51.67
5	522.56	30.47	-64.78	2.72	-62.06	-13	-49.06
6	624.52	35.30	-59.50	1.77	-57.74	-13	-44.74

Remarks:

1. Emission Value (dBm) = S.G Value (dBm) + Correction Factor (dB).
2. Correction Factor (dB) = Substitution Antenna Gain (dB) + Cable Loss (dB).

LTE Band 4: 5MHz

Mode	TX channel 19975	Frequency Range	Below 1000 MHz
------	------------------	-----------------	----------------

Antenna Polarity & Test Distance: Horizontal at 3 M

No.	Freq. (MHz)	Reading (dBm)	S.G Power Value (dBm)	Correction Factor (dB)	Emission Value (dBm)	Limit (dBm)	Margin (dB)
1	75.84	29.96	-64.87	-2.02	-66.88	-13	-53.88
2	128.1	29.34	-62.02	-1.23	-63.25	-13	-50.25
3	277.4	29.32	-65.78	3.86	-61.92	-13	-48.92
4	345.59	27.42	-70.26	3.61	-66.66	-13	-53.66
5	521.66	29.79	-65.47	2.73	-62.74	-13	-49.74
6	623.5	23.52	-71.28	1.77	-69.51	-13	-56.51

Antenna Polarity & Test Distance: Vertical at 3 M

No.	Freq. (MHz)	Reading (dBm)	S.G Power Value (dBm)	Correction Factor (dB)	Emission Value (dBm)	Limit (dBm)	Margin (dB)
1	68.61	27.43	-59.85	-5.08	-64.93	-13	-51.93
2	91.28	29.65	-62.52	-1.13	-63.65	-13	-50.65
3	127.91	29.75	-61.56	-1.23	-62.80	-13	-49.80
4	217.62	26.60	-68.83	4.11	-64.72	-13	-51.72
5	523.13	30.60	-64.65	2.72	-61.93	-13	-48.93
6	623.5	34.38	-60.42	1.77	-58.65	-13	-45.65

Remarks:

1. Emission Value (dBm) = S.G Value (dBm) + Correction Factor (dB).
2. Correction Factor (dB) = Substitution Antenna Gain (dB) + Cable Loss (dB).

Mode	TX channel 20175	Frequency Range	Below 1000 MHz
------	------------------	-----------------	----------------

Antenna Polarity & Test Distance: Horizontal at 3 M

No.	Freq. (MHz)	Reading (dBm)	S.G Power Value (dBm)	Correction Factor (dB)	Emission Value (dBm)	Limit (dBm)	Margin (dB)
1	76.25	30.54	-64.22	-2.00	-66.21	-13	-53.21
2	126.83	29.84	-61.24	-1.23	-62.47	-13	-49.47
3	277.41	29.06	-66.04	3.86	-62.18	-13	-49.18
4	346.28	27.45	-70.26	3.60	-66.66	-13	-53.66
5	522.28	29.99	-65.27	2.72	-62.54	-13	-49.54
6	623.74	23.81	-70.99	1.77	-69.22	-13	-56.22

Antenna Polarity & Test Distance: Vertical at 3 M

No.	Freq. (MHz)	Reading (dBm)	S.G Power Value (dBm)	Correction Factor (dB)	Emission Value (dBm)	Limit (dBm)	Margin (dB)
1	68.81	27.90	-59.50	-5.02	-64.53	-13	-51.53
2	90.89	29.24	-63.00	-1.15	-64.15	-13	-51.15
3	129.35	30.32	-61.31	-1.24	-62.55	-13	-49.55
4	217.99	26.24	-69.19	4.11	-65.09	-13	-52.09
5	522.43	29.90	-65.35	2.72	-62.63	-13	-49.63
6	623.68	34.56	-60.24	1.77	-58.47	-13	-45.47

Remarks:

1. Emission Value (dBm) = S.G Value (dBm) + Correction Factor (dB).
2. Correction Factor (dB) = Substitution Antenna Gain (dB) + Cable Loss (dB).

Mode	TX channel 20375	Frequency Range	Below 1000 MHz
------	------------------	-----------------	----------------

Antenna Polarity & Test Distance: Horizontal at 3 M

No.	Freq. (MHz)	Reading (dBm)	S.G Power Value (dBm)	Correction Factor (dB)	Emission Value (dBm)	Limit (dBm)	Margin (dB)
1	74.74	29.89	-65.13	-2.08	-67.21	-13	-54.21
2	128.37	30.07	-61.34	-1.24	-62.58	-13	-49.58
3	278.47	28.93	-66.20	3.85	-62.35	-13	-49.35
4	346.82	27.06	-70.67	3.60	-67.07	-13	-54.07
5	522.47	29.47	-65.78	2.72	-63.06	-13	-50.06
6	622.46	23.64	-71.15	1.77	-69.38	-13	-56.38

Antenna Polarity & Test Distance: Vertical at 3 M

No.	Freq. (MHz)	Reading (dBm)	S.G Power Value (dBm)	Correction Factor (dB)	Emission Value (dBm)	Limit (dBm)	Margin (dB)
1	68.59	27.19	-60.08	-5.09	-65.17	-13	-52.17
2	90.63	28.86	-63.42	-1.17	-64.59	-13	-51.59
3	128.46	30.06	-61.37	-1.24	-62.61	-13	-49.61
4	217.84	27.04	-68.39	4.11	-64.28	-13	-51.28
5	523.27	30.66	-64.58	2.72	-61.87	-13	-48.87
6	624.79	35.26	-59.55	1.77	-57.78	-13	-44.78

Remarks:

1. Emission Value (dBm) = S.G Value (dBm) + Correction Factor (dB).
2. Correction Factor (dB) = Substitution Antenna Gain (dB) + Cable Loss (dB).

LTE Band 4: 10MHz

Mode	TX channel 20000	Frequency Range	Below 1000 MHz
------	------------------	-----------------	----------------

Antenna Polarity & Test Distance: Horizontal at 3 M

No.	Freq. (MHz)	Reading (dBm)	S.G Power Value (dBm)	Correction Factor (dB)	Emission Value (dBm)	Limit (dBm)	Margin (dB)
1	76.31	29.21	-65.54	-1.99	-67.53	-13	-54.53
2	127	29.36	-61.76	-1.23	-62.98	-13	-49.98
3	277.45	29.66	-65.44	3.86	-61.58	-13	-48.58
4	347.25	26.78	-70.97	3.60	-67.37	-13	-54.37
5	522.55	29.33	-65.92	2.72	-63.20	-13	-50.20
6	622.25	23.74	-71.05	1.77	-69.28	-13	-56.28

Antenna Polarity & Test Distance: Vertical at 3 M

No.	Freq. (MHz)	Reading (dBm)	S.G Power Value (dBm)	Correction Factor (dB)	Emission Value (dBm)	Limit (dBm)	Margin (dB)
1	70.09	27.78	-60.39	-4.65	-65.04	-13	-52.04
2	91.74	28.54	-63.55	-1.10	-64.66	-13	-51.66
3	127.83	30.70	-60.60	-1.23	-61.83	-13	-48.83
4	217.86	26.88	-68.55	4.11	-64.44	-13	-51.44
5	522.87	30.44	-64.81	2.72	-62.09	-13	-49.09
6	624.35	35.51	-59.29	1.77	-57.52	-13	-44.52

Remarks:

1. Emission Value (dBm) = S.G Value (dBm) + Correction Factor (dB).
2. Correction Factor (dB) = Substitution Antenna Gain (dB) + Cable Loss (dB).

Mode	TX channel 20175	Frequency Range	Below 1000 MHz
------	------------------	-----------------	----------------

Antenna Polarity & Test Distance: Horizontal at 3 M

No.	Freq. (MHz)	Reading (dBm)	S.G Power Value (dBm)	Correction Factor (dB)	Emission Value (dBm)	Limit (dBm)	Margin (dB)
1	74.63	29.67	-65.36	-2.09	-67.45	-13	-54.45
2	127.6	29.23	-62.02	-1.23	-63.25	-13	-50.25
3	278.03	29.15	-65.97	3.86	-62.11	-13	-49.11
4	346.9	27.43	-70.31	3.60	-66.70	-13	-53.70
5	523.12	29.73	-65.52	2.72	-62.80	-13	-49.80
6	623.88	23.37	-71.43	1.77	-69.66	-13	-56.66

Antenna Polarity & Test Distance: Vertical at 3 M

No.	Freq. (MHz)	Reading (dBm)	S.G Power Value (dBm)	Correction Factor (dB)	Emission Value (dBm)	Limit (dBm)	Margin (dB)
1	68.78	27.11	-60.28	-5.03	-65.31	-13	-52.31
2	90.94	29.16	-63.07	-1.15	-64.22	-13	-51.22
3	129.19	30.57	-61.02	-1.24	-62.26	-13	-49.26
4	217.81	26.36	-69.07	4.11	-64.96	-13	-51.96
5	522.58	30.83	-64.42	2.72	-61.70	-13	-48.70
6	624.78	35.18	-59.63	1.77	-57.86	-13	-44.86

Remarks:

1. Emission Value (dBm) = S.G Value (dBm) + Correction Factor (dB).
2. Correction Factor (dB) = Substitution Antenna Gain (dB) + Cable Loss (dB).

Mode	TX channel 20350	Frequency Range	Below 1000 MHz
------	------------------	-----------------	----------------

Antenna Polarity & Test Distance: Horizontal at 3 M

No.	Freq. (MHz)	Reading (dBm)	S.G Power Value (dBm)	Correction Factor (dB)	Emission Value (dBm)	Limit (dBm)	Margin (dB)
1	76.07	29.42	-65.37	-2.01	-67.37	-13	-54.37
2	127.24	29.64	-61.53	-1.23	-62.76	-13	-49.76
3	278.98	29.96	-65.19	3.85	-61.34	-13	-48.34
4	345.48	27.06	-70.62	3.61	-67.01	-13	-54.01
5	522.91	29.46	-65.79	2.72	-63.07	-13	-50.07
6	622.33	23.96	-70.83	1.77	-69.06	-13	-56.06

Antenna Polarity & Test Distance: Vertical at 3 M

No.	Freq. (MHz)	Reading (dBm)	S.G Power Value (dBm)	Correction Factor (dB)	Emission Value (dBm)	Limit (dBm)	Margin (dB)
1	69.92	27.15	-60.92	-4.70	-65.62	-13	-52.62
2	91.03	29.39	-62.82	-1.14	-63.97	-13	-50.97
3	127.55	29.54	-61.70	-1.23	-62.93	-13	-49.93
4	217.81	26.01	-69.42	4.11	-65.31	-13	-52.31
5	523.31	31.00	-64.24	2.72	-61.53	-13	-48.53
6	623.3	35.58	-59.21	1.77	-57.45	-13	-44.45

Remarks:

1. Emission Value (dBm) = S.G Value (dBm) + Correction Factor (dB).
2. Correction Factor (dB) = Substitution Antenna Gain (dB) + Cable Loss (dB).

LTE Band 4: 15MHz

Mode	TX channel 20025	Frequency Range	Below 1000 MHz
------	------------------	-----------------	----------------

Antenna Polarity & Test Distance: Horizontal at 3 M

No.	Freq. (MHz)	Reading (dBm)	S.G Power Value (dBm)	Correction Factor (dB)	Emission Value (dBm)	Limit (dBm)	Margin (dB)
1	76.21	29.57	-65.19	-2.00	-67.19	-13	-54.19
2	126.81	29.64	-61.44	-1.23	-62.66	-13	-49.66
3	277.38	28.93	-66.17	3.86	-62.31	-13	-49.31
4	346.72	27.54	-70.19	3.60	-66.59	-13	-53.59
5	522.71	29.89	-65.36	2.72	-62.64	-13	-49.64
6	621.97	24.03	-70.75	1.77	-68.98	-13	-55.98

Antenna Polarity & Test Distance: Vertical at 3 M

No.	Freq. (MHz)	Reading (dBm)	S.G Power Value (dBm)	Correction Factor (dB)	Emission Value (dBm)	Limit (dBm)	Margin (dB)
1	69.83	27.09	-60.92	-4.73	-65.65	-13	-52.65
2	91.16	28.57	-63.62	-1.14	-64.76	-13	-51.76
3	128.68	29.44	-62.04	-1.24	-63.28	-13	-50.28
4	217.86	27.27	-68.16	4.11	-64.05	-13	-51.05
5	521.73	29.98	-65.28	2.73	-62.55	-13	-49.55
6	623.93	34.28	-60.52	1.77	-58.75	-13	-45.75

Remarks:

1. Emission Value (dBm) = S.G Value (dBm) + Correction Factor (dB).
2. Correction Factor (dB) = Substitution Antenna Gain (dB) + Cable Loss (dB).

Mode	TX channel 20175	Frequency Range	Below 1000 MHz
------	------------------	-----------------	----------------

Antenna Polarity & Test Distance: Horizontal at 3 M

No.	Freq. (MHz)	Reading (dBm)	S.G Power Value (dBm)	Correction Factor (dB)	Emission Value (dBm)	Limit (dBm)	Margin (dB)
1	75.26	29.99	-64.94	-2.05	-66.99	-13	-53.99
2	127.02	28.77	-62.35	-1.23	-63.58	-13	-50.58
3	279.29	29.48	-65.68	3.85	-61.83	-13	-48.83
4	346.49	26.75	-70.97	3.60	-67.37	-13	-54.37
5	522.42	29.04	-66.21	2.72	-63.49	-13	-50.49
6	622.16	24.11	-70.68	1.77	-68.91	-13	-55.91

Antenna Polarity & Test Distance: Vertical at 3 M

No.	Freq. (MHz)	Reading (dBm)	S.G Power Value (dBm)	Correction Factor (dB)	Emission Value (dBm)	Limit (dBm)	Margin (dB)
1	69.02	27.78	-59.75	-4.96	-64.71	-13	-51.71
2	90.36	29.82	-62.51	-1.18	-63.69	-13	-50.69
3	128.35	29.68	-61.73	-1.24	-62.97	-13	-49.97
4	217.08	26.85	-68.58	4.12	-64.47	-13	-51.47
5	522.77	29.97	-65.28	2.72	-62.56	-13	-49.56
6	625	34.27	-60.54	1.77	-58.77	-13	-45.77

Remarks:

1. Emission Value (dBm) = S.G Value (dBm) + Correction Factor (dB).
2. Correction Factor (dB) = Substitution Antenna Gain (dB) + Cable Loss (dB).

Mode	TX channel 20325	Frequency Range	Below 1000 MHz
------	------------------	-----------------	----------------

Antenna Polarity & Test Distance: Horizontal at 3 M

No.	Freq. (MHz)	Reading (dBm)	S.G Power Value (dBm)	Correction Factor (dB)	Emission Value (dBm)	Limit (dBm)	Margin (dB)
1	75.1	30.47	-64.48	-2.06	-66.54	-13	-53.54
2	128.04	28.68	-62.66	-1.23	-63.90	-13	-50.90
3	278.49	29.15	-65.98	3.85	-62.13	-13	-49.13
4	345.87	26.27	-71.42	3.60	-67.82	-13	-54.82
5	521.32	29.93	-65.34	2.73	-62.61	-13	-49.61
6	622.59	24.07	-70.72	1.77	-68.95	-13	-55.95

Antenna Polarity & Test Distance: Vertical at 3 M

No.	Freq. (MHz)	Reading (dBm)	S.G Power Value (dBm)	Correction Factor (dB)	Emission Value (dBm)	Limit (dBm)	Margin (dB)
1	68.95	27.54	-59.95	-4.98	-64.93	-13	-51.93
2	91.88	29.32	-62.75	-1.09	-63.84	-13	-50.84
3	128.48	30.42	-61.02	-1.24	-62.26	-13	-49.26
4	216.99	26.74	-68.69	4.12	-64.58	-13	-51.58
5	522.07	29.93	-65.33	2.73	-62.60	-13	-49.60
6	623.77	34.89	-59.91	1.77	-58.14	-13	-45.14

Remarks:

1. Emission Value (dBm) = S.G Value (dBm) + Correction Factor (dB).
2. Correction Factor (dB) = Substitution Antenna Gain (dB) + Cable Loss (dB).

LTE Band 4: 20MHz

Mode	TX channel 20050	Frequency Range	Below 1000 MHz
------	------------------	-----------------	----------------

Antenna Polarity & Test Distance: Horizontal at 3 M

No.	Freq. (MHz)	Reading (dBm)	S.G Power Value (dBm)	Correction Factor (dB)	Emission Value (dBm)	Limit (dBm)	Margin (dB)
1	76.44	30.21	-64.51	-1.98	-66.50	-13	-53.50
2	128.6	29.88	-61.58	-1.24	-62.82	-13	-49.82
3	277.54	29.72	-65.38	3.86	-61.52	-13	-48.52
4	345.54	26.85	-70.83	3.61	-67.22	-13	-54.22
5	521.69	29.45	-65.81	2.73	-63.08	-13	-50.08
6	623.83	23.52	-71.28	1.77	-69.51	-13	-56.51

Antenna Polarity & Test Distance: Vertical at 3 M

No.	Freq. (MHz)	Reading (dBm)	S.G Power Value (dBm)	Correction Factor (dB)	Emission Value (dBm)	Limit (dBm)	Margin (dB)
1	69.2	27.66	-59.98	-4.91	-64.89	-13	-51.89
2	90.85	29.35	-62.90	-1.15	-64.05	-13	-51.05
3	128.21	29.73	-61.65	-1.24	-62.88	-13	-49.88
4	217.13	26.13	-69.30	4.12	-65.19	-13	-52.19
5	523.14	30.94	-64.31	2.72	-61.59	-13	-48.59
6	624.65	35.42	-59.38	1.77	-57.62	-13	-44.62

Remarks:

1. Emission Value (dBm) = S.G Value (dBm) + Correction Factor (dB).
2. Correction Factor (dB) = Substitution Antenna Gain (dB) + Cable Loss (dB).

Mode	TX channel 20175	Frequency Range	Below 1000 MHz
------	------------------	-----------------	----------------

Antenna Polarity & Test Distance: Horizontal at 3 M

No.	Freq. (MHz)	Reading (dBm)	S.G Power Value (dBm)	Correction Factor (dB)	Emission Value (dBm)	Limit (dBm)	Margin (dB)
1	76.22	29.82	-64.94	-2.00	-66.94	-13	-53.94
2	128.53	29.49	-61.96	-1.24	-63.20	-13	-50.20
3	278.57	29.97	-65.17	3.85	-61.31	-13	-48.31
4	346.23	26.54	-71.17	3.60	-67.56	-13	-54.56
5	522.02	29.25	-66.01	2.73	-63.28	-13	-50.28
6	623.48	23.51	-71.29	1.77	-69.52	-13	-56.52

Antenna Polarity & Test Distance: Vertical at 3 M

No.	Freq. (MHz)	Reading (dBm)	S.G Power Value (dBm)	Correction Factor (dB)	Emission Value (dBm)	Limit (dBm)	Margin (dB)
1	69.25	27.11	-60.56	-4.90	-65.45	-13	-52.45
2	90.42	28.43	-63.89	-1.18	-65.07	-13	-52.07
3	128.54	29.76	-61.69	-1.24	-62.93	-13	-49.93
4	218.4	26.66	-68.77	4.10	-64.67	-13	-51.67
5	522.23	31.37	-63.89	2.72	-61.16	-13	-48.16
6	623.55	34.73	-60.07	1.77	-58.30	-13	-45.30

Remarks:

1. Emission Value (dBm) = S.G Value (dBm) + Correction Factor (dB).
2. Correction Factor (dB) = Substitution Antenna Gain (dB) + Cable Loss (dB).

Mode	TX channel 20300	Frequency Range	Below 1000 MHz
------	------------------	-----------------	----------------

Antenna Polarity & Test Distance: Horizontal at 3 M

No.	Freq. (MHz)	Reading (dBm)	S.G Power Value (dBm)	Correction Factor (dB)	Emission Value (dBm)	Limit (dBm)	Margin (dB)
1	75.78	29.45	-65.39	-2.02	-67.41	-13	-54.41
2	128.02	29.43	-61.91	-1.23	-63.14	-13	-50.14
3	277.95	29.49	-65.63	3.86	-61.77	-13	-48.77
4	345.67	27.41	-70.27	3.61	-66.67	-13	-53.67
5	522.23	29.72	-65.54	2.72	-62.81	-13	-49.81
6	622.04	23.67	-71.12	1.77	-69.35	-13	-56.35

Antenna Polarity & Test Distance: Vertical at 3 M

No.	Freq. (MHz)	Reading (dBm)	S.G Power Value (dBm)	Correction Factor (dB)	Emission Value (dBm)	Limit (dBm)	Margin (dB)
1	69.67	27.50	-60.42	-4.77	-65.19	-13	-52.19
2	90.1	29.53	-62.84	-1.20	-64.04	-13	-51.04
3	129.16	30.73	-60.86	-1.24	-62.10	-13	-49.10
4	217.61	26.46	-68.97	4.11	-64.86	-13	-51.86
5	523.09	30.73	-64.52	2.72	-61.80	-13	-48.80
6	624.97	35.64	-59.17	1.77	-57.40	-13	-44.40

Remarks:

1. Emission Value (dBm) = S.G Value (dBm) + Correction Factor (dB).
2. Correction Factor (dB) = Substitution Antenna Gain (dB) + Cable Loss (dB).

LTE Band 12: 1.4MHz

Mode	TX channel 23017	Frequency Range	Below 1000 MHz
------	------------------	-----------------	----------------

Antenna Polarity & Test Distance: Horizontal at 3 M

No.	Freq. (MHz)	Reading (dBm)	S.G Power Value (dBm)	Correction Factor (dB)	Emission Value (dBm)	Limit (dBm)	Margin (dB)
1	75.56	30.58	-64.29	-2.03	-66.33	-13	-53.33
2	127.75	30.09	-61.19	-1.23	-62.42	-13	-49.42
3	278.33	30.20	-64.93	3.85	-61.07	-13	-48.07
4	346.32	27.72	-69.99	3.60	-66.39	-13	-53.39
5	522.28	30.51	-64.75	2.72	-62.02	-13	-49.02
6	622.94	24.32	-70.47	1.77	-68.70	-13	-55.70

Antenna Polarity & Test Distance: Vertical at 3 M

No.	Freq. (MHz)	Reading (dBm)	S.G Power Value (dBm)	Correction Factor (dB)	Emission Value (dBm)	Limit (dBm)	Margin (dB)
1	65.8	29.00	-56.60	-5.90	-62.50	-13	-49.50
2	94.3	30.24	-61.41	-0.96	-62.37	-13	-49.37
3	131.36	31.84	-60.22	-1.26	-61.48	-13	-48.48
4	238.3	27.26	-68.10	3.84	-64.26	-13	-51.26
5	508.42	31.71	-63.71	2.83	-60.88	-13	-47.88
6	609.11	35.90	-58.79	1.78	-57.01	-13	-44.01

Remarks:

1. Emission Value (dBm) = S.G Value (dBm) + Correction Factor (dB).
2. Correction Factor (dB) = Substitution Antenna Gain (dB) + Cable Loss (dB).

Mode	TX channel 23095	Frequency Range	Below 1000 MHz
------	------------------	-----------------	----------------

Antenna Polarity & Test Distance: Horizontal at 3 M

No.	Freq. (MHz)	Reading (dBm)	S.G Power Value (dBm)	Correction Factor (dB)	Emission Value (dBm)	Limit (dBm)	Margin (dB)
1	75.05	29.98	-64.98	-2.06	-67.05	-13	-54.05
2	127.17	29.85	-61.30	-1.23	-62.53	-13	-49.53
3	277.62	29.65	-65.46	3.86	-61.60	-13	-48.60
4	345.82	26.71	-70.98	3.60	-67.38	-13	-54.38
5	521.47	29.77	-65.50	2.73	-62.77	-13	-49.77
6	622.01	23.98	-70.81	1.77	-69.03	-13	-56.03

Antenna Polarity & Test Distance: Vertical at 3 M

No.	Freq. (MHz)	Reading (dBm)	S.G Power Value (dBm)	Correction Factor (dB)	Emission Value (dBm)	Limit (dBm)	Margin (dB)
1	66.19	27.52	-58.31	-5.78	-64.10	-13	-51.10
2	94.28	29.58	-62.08	-0.96	-63.03	-13	-50.03
3	131.92	30.74	-61.45	-1.26	-62.70	-13	-49.70
4	237.54	26.57	-68.79	3.85	-64.95	-13	-51.95
5	508.49	31.64	-63.78	2.83	-60.95	-13	-47.95
6	609.37	35.59	-59.10	1.78	-57.32	-13	-44.32

Remarks:

1. Emission Value (dBm) = S.G Value (dBm) + Correction Factor (dB).
2. Correction Factor (dB) = Substitution Antenna Gain (dB) + Cable Loss (dB).

Mode	TX channel 23173	Frequency Range	Below 1000 MHz
------	------------------	-----------------	----------------

Antenna Polarity & Test Distance: Horizontal at 3 M

No.	Freq. (MHz)	Reading (dBm)	S.G Power Value (dBm)	Correction Factor (dB)	Emission Value (dBm)	Limit (dBm)	Margin (dB)
1	76.37	29.75	-64.98	-1.99	-66.97	-13	-53.97
2	126.89	29.05	-62.04	-1.23	-63.27	-13	-50.27
3	279.2	30.07	-65.08	3.85	-61.24	-13	-48.24
4	345.69	26.80	-70.89	3.61	-67.28	-13	-54.28
5	521.84	29.26	-66.00	2.73	-63.27	-13	-50.27
6	622.03	23.97	-70.82	1.77	-69.05	-13	-56.05

Antenna Polarity & Test Distance: Vertical at 3 M

No.	Freq. (MHz)	Reading (dBm)	S.G Power Value (dBm)	Correction Factor (dB)	Emission Value (dBm)	Limit (dBm)	Margin (dB)
1	65.11	27.80	-57.39	-6.10	-63.48	-13	-50.48
2	93.45	29.82	-61.98	-1.00	-62.98	-13	-49.98
3	130.63	30.60	-61.31	-1.25	-62.56	-13	-49.56
4	238.92	25.85	-69.51	3.83	-65.68	-13	-52.68
5	509.03	31.66	-63.75	2.82	-60.93	-13	-47.93
6	608.95	34.60	-60.09	1.78	-58.31	-13	-45.31

Remarks:

1. Emission Value (dBm) = S.G Value (dBm) + Correction Factor (dB).
2. Correction Factor (dB) = Substitution Antenna Gain (dB) + Cable Loss (dB).

LTE Band 12: 3MHz

Mode	TX channel 23025	Frequency Range	Below 1000 MHz
------	------------------	-----------------	----------------

Antenna Polarity & Test Distance: Horizontal at 3 M

No.	Freq. (MHz)	Reading (dBm)	S.G Power Value (dBm)	Correction Factor (dB)	Emission Value (dBm)	Limit (dBm)	Margin (dB)
1	65.72	27.61	-57.94	-5.92	-63.86	-13	-50.86
2	94.91	29.78	-61.77	-0.92	-62.69	-13	-49.69
3	132.01	31.20	-61.00	-1.26	-62.26	-13	-49.26
4	237.63	26.65	-68.71	3.85	-64.87	-13	-51.87
5	507.49	31.30	-64.13	2.83	-61.30	-13	-48.30
6	609.18	35.11	-59.58	1.78	-57.80	-13	-44.80

Antenna Polarity & Test Distance: Vertical at 3 M

No.	Freq. (MHz)	Reading (dBm)	S.G Power Value (dBm)	Correction Factor (dB)	Emission Value (dBm)	Limit (dBm)	Margin (dB)
1	74.83	30.27	-64.73	-2.08	-66.81	-13	-53.81
2	128.68	29.73	-61.75	-1.24	-62.99	-13	-49.99
3	279.01	28.87	-66.28	3.85	-62.43	-13	-49.43
4	345.8	27.13	-70.56	3.60	-66.96	-13	-53.96
5	523.27	29.96	-65.28	2.72	-62.57	-13	-49.57
6	621.96	23.79	-70.99	1.77	-69.22	-13	-56.22

Remarks:

1. Emission Value (dBm) = S.G Value (dBm) + Correction Factor (dB).
2. Correction Factor (dB) = Substitution Antenna Gain (dB) + Cable Loss (dB).

Mode	TX channel 23095	Frequency Range	Below 1000 MHz
------	------------------	-----------------	----------------

Antenna Polarity & Test Distance: Horizontal at 3 M

No.	Freq. (MHz)	Reading (dBm)	S.G Power Value (dBm)	Correction Factor (dB)	Emission Value (dBm)	Limit (dBm)	Margin (dB)
1	75.03	29.41	-65.56	-2.07	-67.62	-13	-54.62
2	128.5	29.36	-62.08	-1.24	-63.32	-13	-50.32
3	278.59	29.03	-66.11	3.85	-62.25	-13	-49.25
4	346.99	27.27	-70.47	3.60	-66.87	-13	-53.87
5	521.3	30.16	-65.11	2.73	-62.38	-13	-49.38
6	623.63	23.28	-71.52	1.77	-69.75	-13	-56.75

Antenna Polarity & Test Distance: Vertical at 3 M

No.	Freq. (MHz)	Reading (dBm)	S.G Power Value (dBm)	Correction Factor (dB)	Emission Value (dBm)	Limit (dBm)	Margin (dB)
1	65.62	28.45	-57.04	-5.95	-62.99	-13	-49.99
2	94.24	29.20	-62.46	-0.96	-63.42	-13	-50.42
3	131.14	30.51	-61.51	-1.25	-62.76	-13	-49.76
4	237.82	27.20	-68.16	3.84	-64.32	-13	-51.32
5	508.94	30.61	-64.80	2.82	-61.98	-13	-48.98
6	608.53	34.99	-59.69	1.78	-57.91	-13	-44.91

Remarks:

1. Emission Value (dBm) = S.G Value (dBm) + Correction Factor (dB).
2. Correction Factor (dB) = Substitution Antenna Gain (dB) + Cable Loss (dB).

Mode	TX channel 23165	Frequency Range	Below 1000 MHz
------	------------------	-----------------	----------------

Antenna Polarity & Test Distance: Horizontal at 3 M

No.	Freq. (MHz)	Reading (dBm)	S.G Power Value (dBm)	Correction Factor (dB)	Emission Value (dBm)	Limit (dBm)	Margin (dB)
1	75.13	30.13	-64.82	-2.06	-66.88	-13	-53.88
2	127.63	29.20	-62.05	-1.23	-63.29	-13	-50.29
3	279.11	29.07	-66.08	3.85	-62.23	-13	-49.23
4	346.01	26.78	-70.92	3.60	-67.31	-13	-54.31
5	522.14	29.57	-65.69	2.73	-62.96	-13	-49.96
6	623.8	24.14	-70.66	1.77	-68.89	-13	-55.89

Antenna Polarity & Test Distance: Vertical at 3 M

No.	Freq. (MHz)	Reading (dBm)	S.G Power Value (dBm)	Correction Factor (dB)	Emission Value (dBm)	Limit (dBm)	Margin (dB)
1	65.19	27.66	-57.57	-6.07	-63.65	-13	-50.65
2	93.91	29.61	-62.11	-0.98	-63.09	-13	-50.09
3	130.44	31.26	-60.60	-1.25	-61.85	-13	-48.85
4	237.58	26.98	-68.38	3.85	-64.54	-13	-51.54
5	508.48	31.54	-63.88	2.83	-61.05	-13	-48.05
6	608.39	34.67	-60.01	1.78	-58.23	-13	-45.23

Remarks:

1. Emission Value (dBm) = S.G Value (dBm) + Correction Factor (dB).
2. Correction Factor (dB) = Substitution Antenna Gain (dB) + Cable Loss (dB).

LTE Band 12: 5MHz

Mode	TX channel 23035	Frequency Range	Below 1000 MHz
------	------------------	-----------------	----------------

Antenna Polarity & Test Distance: Horizontal at 3 M

No.	Freq. (MHz)	Reading (dBm)	S.G Power Value (dBm)	Correction Factor (dB)	Emission Value (dBm)	Limit (dBm)	Margin (dB)
1	75.38	29.23	-65.68	-2.05	-67.72	-13	-54.72
2	127.24	29.75	-61.42	-1.23	-62.65	-13	-49.65
3	278.11	29.76	-65.36	3.86	-61.51	-13	-48.51
4	347.29	27.18	-70.57	3.60	-66.97	-13	-53.97
5	522.52	30.48	-64.77	2.72	-62.05	-13	-49.05
6	622.56	23.73	-71.06	1.77	-69.29	-13	-56.29

Antenna Polarity & Test Distance: Vertical at 3 M

No.	Freq. (MHz)	Reading (dBm)	S.G Power Value (dBm)	Correction Factor (dB)	Emission Value (dBm)	Limit (dBm)	Margin (dB)
1	66.48	27.60	-58.41	-5.70	-64.11	-13	-51.11
2	93.92	29.02	-62.70	-0.98	-63.68	-13	-50.68
3	131.55	30.88	-61.23	-1.26	-62.48	-13	-49.48
4	239.17	25.81	-69.55	3.83	-65.72	-13	-52.72
5	508.22	30.63	-64.79	2.83	-61.96	-13	-48.96
6	608.55	35.52	-59.16	1.78	-57.38	-13	-44.38

Remarks:

1. Emission Value (dBm) = S.G Value (dBm) + Correction Factor (dB).
2. Correction Factor (dB) = Substitution Antenna Gain (dB) + Cable Loss (dB).

Mode	TX channel 23095	Frequency Range	Below 1000 MHz
------	------------------	-----------------	----------------

Antenna Polarity & Test Distance: Horizontal at 3 M

No.	Freq. (MHz)	Reading (dBm)	S.G Power Value (dBm)	Correction Factor (dB)	Emission Value (dBm)	Limit (dBm)	Margin (dB)
1	76.18	29.86	-64.91	-2.00	-66.91	-13	-53.91
2	127.99	29.21	-62.12	-1.23	-63.36	-13	-50.36
3	278.17	29.53	-65.59	3.86	-61.74	-13	-48.74
4	347.23	27.30	-70.45	3.60	-66.85	-13	-53.85
5	523.07	29.03	-66.22	2.72	-63.50	-13	-50.50
6	623.74	23.26	-71.54	1.77	-69.77	-13	-56.77

Antenna Polarity & Test Distance: Vertical at 3 M

No.	Freq. (MHz)	Reading (dBm)	S.G Power Value (dBm)	Correction Factor (dB)	Emission Value (dBm)	Limit (dBm)	Margin (dB)
1	65.7	27.67	-57.87	-5.93	-63.79	-13	-50.79
2	93.97	29.32	-62.39	-0.97	-63.36	-13	-50.36
3	131.68	31.23	-60.90	-1.26	-62.16	-13	-49.16
4	238.9	25.92	-69.44	3.83	-65.61	-13	-52.61
5	509.34	31.61	-63.80	2.82	-60.98	-13	-47.98
6	608.5	34.94	-59.74	1.78	-57.96	-13	-44.96

Remarks:

1. Emission Value (dBm) = S.G Value (dBm) + Correction Factor (dB).
2. Correction Factor (dB) = Substitution Antenna Gain (dB) + Cable Loss (dB).

Mode	TX channel 23155	Frequency Range	Below 1000 MHz
------	------------------	-----------------	----------------

Antenna Polarity & Test Distance: Horizontal at 3 M

No.	Freq. (MHz)	Reading (dBm)	S.G Power Value (dBm)	Correction Factor (dB)	Emission Value (dBm)	Limit (dBm)	Margin (dB)
1	75.31	29.16	-65.76	-2.05	-67.81	-13	-54.81
2	128	29.74	-61.59	-1.23	-62.83	-13	-49.83
3	278.06	29.64	-65.48	3.86	-61.62	-13	-48.62
4	346.09	26.88	-70.82	3.60	-67.22	-13	-54.22
5	522.89	29.38	-65.87	2.72	-63.15	-13	-50.15
6	623.36	24.20	-70.60	1.77	-68.83	-13	-55.83

Antenna Polarity & Test Distance: Vertical at 3 M

No.	Freq. (MHz)	Reading (dBm)	S.G Power Value (dBm)	Correction Factor (dB)	Emission Value (dBm)	Limit (dBm)	Margin (dB)
1	64.96	28.88	-56.22	-6.14	-62.36	-13	-49.36
2	93.68	29.77	-61.99	-0.99	-62.98	-13	-49.98
3	130.94	30.57	-61.40	-1.25	-62.66	-13	-49.66
4	237.84	25.97	-69.39	3.84	-65.55	-13	-52.55
5	508.55	31.10	-64.32	2.83	-61.49	-13	-48.49
6	610.1	35.34	-59.36	1.78	-57.57	-13	-44.57

Remarks:

1. Emission Value (dBm) = S.G Value (dBm) + Correction Factor (dB).
2. Correction Factor (dB) = Substitution Antenna Gain (dB) + Cable Loss (dB).

LTE Band 12: 10MHz

Mode	TX channel 23060	Frequency Range	Below 1000 MHz
------	------------------	-----------------	----------------

Antenna Polarity & Test Distance: Horizontal at 3 M

No.	Freq. (MHz)	Reading (dBm)	S.G Power Value (dBm)	Correction Factor (dB)	Emission Value (dBm)	Limit (dBm)	Margin (dB)
1	74.99	29.60	-65.37	-2.07	-67.44	-13	-54.44
2	128.37	29.52	-61.89	-1.24	-63.13	-13	-50.13
3	278.87	29.48	-65.66	3.85	-61.81	-13	-48.81
4	345.44	26.82	-70.86	3.61	-67.25	-13	-54.25
5	522.6	30.48	-64.77	2.72	-62.05	-13	-49.05
6	622.25	24.30	-70.49	1.77	-68.72	-13	-55.72

Antenna Polarity & Test Distance: Vertical at 3 M

No.	Freq. (MHz)	Reading (dBm)	S.G Power Value (dBm)	Correction Factor (dB)	Emission Value (dBm)	Limit (dBm)	Margin (dB)
1	66.67	28.39	-57.73	-5.64	-63.37	-13	-50.37
2	93.87	29.17	-62.56	-0.98	-63.54	-13	-50.54
3	131.32	30.37	-61.69	-1.25	-62.94	-13	-49.94
4	239.12	26.30	-69.06	3.83	-65.23	-13	-52.23
5	508.28	30.26	-65.16	2.83	-62.33	-13	-49.33
6	609.59	34.59	-60.10	1.78	-58.32	-13	-45.32

Remarks:

1. Emission Value (dBm) = S.G Value (dBm) + Correction Factor (dB).
2. Correction Factor (dB) = Substitution Antenna Gain (dB) + Cable Loss (dB).

Mode	TX channel 23095	Frequency Range	Below 1000 MHz
------	------------------	-----------------	----------------

Antenna Polarity & Test Distance: Horizontal at 3 M

No.	Freq. (MHz)	Reading (dBm)	S.G Power Value (dBm)	Correction Factor (dB)	Emission Value (dBm)	Limit (dBm)	Margin (dB)
1	74.86	30.56	-64.43	-2.08	-66.51	-13	-53.51
2	128.3	28.72	-62.68	-1.24	-63.92	-13	-50.92
3	278.2	30.01	-65.11	3.86	-61.26	-13	-48.26
4	345.79	27.69	-70.00	3.60	-66.39	-13	-53.39
5	521.74	29.66	-65.60	2.73	-62.87	-13	-49.87
6	622.67	23.51	-71.28	1.77	-69.51	-13	-56.51

Antenna Polarity & Test Distance: Vertical at 3 M

No.	Freq. (MHz)	Reading (dBm)	S.G Power Value (dBm)	Correction Factor (dB)	Emission Value (dBm)	Limit (dBm)	Margin (dB)
1	66.14	27.80	-58.00	-5.80	-63.80	-13	-50.80
2	94.34	28.79	-62.86	-0.95	-63.81	-13	-50.81
3	130.4	30.38	-61.48	-1.25	-62.72	-13	-49.72
4	237.81	26.34	-69.02	3.84	-65.18	-13	-52.18
5	508.31	31.13	-64.29	2.83	-61.46	-13	-48.46
6	609.27	34.72	-59.97	1.78	-58.19	-13	-45.19

Remarks:

1. Emission Value (dBm) = S.G Value (dBm) + Correction Factor (dB).
2. Correction Factor (dB) = Substitution Antenna Gain (dB) + Cable Loss (dB).

Mode	TX channel 23130	Frequency Range	Below 1000 MHz
------	------------------	-----------------	----------------

Antenna Polarity & Test Distance: Horizontal at 3 M

No.	Freq. (MHz)	Reading (dBm)	S.G Power Value (dBm)	Correction Factor (dB)	Emission Value (dBm)	Limit (dBm)	Margin (dB)
1	75.86	30.43	-64.39	-2.02	-66.41	-13	-53.41
2	128.02	29.39	-61.95	-1.23	-63.18	-13	-50.18
3	278.15	29.33	-65.79	3.86	-61.94	-13	-48.94
4	345.93	26.79	-70.91	3.60	-67.30	-13	-54.30
5	523.14	30.25	-65.00	2.72	-62.28	-13	-49.28
6	623.43	23.46	-71.34	1.77	-69.57	-13	-56.57

Antenna Polarity & Test Distance: Vertical at 3 M

No.	Freq. (MHz)	Reading (dBm)	S.G Power Value (dBm)	Correction Factor (dB)	Emission Value (dBm)	Limit (dBm)	Margin (dB)
1	64.84	28.13	-56.89	-6.17	-63.07	-13	-50.07
2	94.85	30.19	-61.37	-0.92	-62.29	-13	-49.29
3	131.62	30.75	-61.37	-1.26	-62.63	-13	-49.63
4	237.4	25.79	-69.57	3.85	-65.72	-13	-52.72
5	507.84	31.66	-63.77	2.83	-60.94	-13	-47.94
6	609.27	35.50	-59.19	1.78	-57.41	-13	-44.41

Remarks:

1. Emission Value (dBm) = S.G Value (dBm) + Correction Factor (dB).
2. Correction Factor (dB) = Substitution Antenna Gain (dB) + Cable Loss (dB).

ABOVE 1GHz

LTE Band 4: 1.4MHz

Mode	TX channel 19957	Frequency Range	Above 1000 MHz
------	------------------	-----------------	----------------

Antenna Polarity & Test Distance: Horizontal at 3 M							
No.	Freq. (MHz)	Reading (dBm)	S.G Power Value (dBm)	Correction Factor (dB)	Emission Value (dBm)	Limit (dBm)	Margin (dB)
1	3421.4	56.82	-46.28	7.74	-38.55	-13	-25.55
2	5132.1	52.66	-51.77	7.04	-44.73	-13	-31.73
3	6842.8	44.1	-58.59	5.27	-53.31	-13	-40.31
Antenna Polarity & Test Distance: Vertical at 3 M							
No.	Freq. (MHz)	Reading (dBm)	S.G Power Value (dBm)	Correction Factor (dB)	Emission Value (dBm)	Limit (dBm)	Margin (dB)
1	3421.4	49.02	-54.08	7.74	-46.35	-13	-33.35
2	5132.1	54.08	-50.35	7.04	-43.31	-13	-30.31
3	6842.8	43.09	-59.60	5.27	-54.32	-13	-41.32

Remarks:

1. Emission Value (dBm) = S.G Value (dBm) + Correction Factor (dB).
2. Correction Factor (dB) = Substitution Antenna Gain (dB) + Cable Loss (dB).

Mode	TX channel 20175	Frequency Range	Above 1000 MHz
------	------------------	-----------------	----------------

Antenna Polarity & Test Distance: Horizontal at 3 M

No.	Freq. (MHz)	Reading (dBm)	S.G Power Value (dBm)	Correction Factor (dB)	Emission Value (dBm)	Limit (dBm)	Margin (dB)
1	3465	57.58	-45.58	7.80	-37.78	-13	-24.78
2	5197.5	52.75	-51.78	7.05	-44.72	-13	-31.72
3	6930	44.02	-58.30	5.10	-53.19	-13	-40.19

Antenna Polarity & Test Distance: Vertical at 3 M

No.	Freq. (MHz)	Reading (dBm)	S.G Power Value (dBm)	Correction Factor (dB)	Emission Value (dBm)	Limit (dBm)	Margin (dB)
1	3465	49.12	-54.04	7.80	-46.24	-13	-33.24
2	5197.5	54.88	-49.65	7.05	-42.59	-13	-29.59
3	6930	43.48	-58.84	5.10	-53.73	-13	-40.73

Remarks:

1. Emission Value (dBm) = S.G Value (dBm) + Correction Factor (dB).
2. Correction Factor (dB) = Substitution Antenna Gain (dB) + Cable Loss (dB).

Mode	TX channel 20393	Frequency Range	Above 1000 MHz
------	------------------	-----------------	----------------

Antenna Polarity & Test Distance: Horizontal at 3 M

No.	Freq. (MHz)	Reading (dBm)	S.G Power Value (dBm)	Correction Factor (dB)	Emission Value (dBm)	Limit (dBm)	Margin (dB)
1	3508.6	56.85	-46.38	7.84	-38.54	-13	-25.54
2	5262.9	52.92	-51.70	7.07	-44.64	-13	-31.64
3	7017.2	43.29	-58.75	4.96	-53.79	-13	-40.79

Antenna Polarity & Test Distance: Vertical at 3 M

No.	Freq. (MHz)	Reading (dBm)	S.G Power Value (dBm)	Correction Factor (dB)	Emission Value (dBm)	Limit (dBm)	Margin (dB)
1	3508.6	48.91	-54.32	7.84	-46.48	-13	-33.48
2	5262.9	53.71	-50.91	7.07	-43.85	-13	-30.85
3	7017.2	42.60	-59.44	4.96	-54.48	-13	-41.48

Remarks:

1. Emission Value (dBm) = S.G Value (dBm) + Correction Factor (dB).
2. Correction Factor (dB) = Substitution Antenna Gain (dB) + Cable Loss (dB).

LTE Band 4: 3MHz

Mode	TX channel 19965	Frequency Range	Above 1000 MHz
------	------------------	-----------------	----------------

Antenna Polarity & Test Distance: Horizontal at 3 M

No.	Freq. (MHz)	Reading (dBm)	S.G Power Value (dBm)	Correction Factor (dB)	Emission Value (dBm)	Limit (dBm)	Margin (dB)
1	3423	57.76	-45.35	7.74	-37.61	-13	-24.61
2	5134.5	51.76	-52.67	7.04	-45.63	-13	-32.63
3	6846	43.29	-59.38	5.27	-54.12	-13	-41.12

Antenna Polarity & Test Distance: Vertical at 3 M

No.	Freq. (MHz)	Reading (dBm)	S.G Power Value (dBm)	Correction Factor (dB)	Emission Value (dBm)	Limit (dBm)	Margin (dB)
1	3423	49.99	-53.12	7.74	-45.38	-13	-32.38
2	5134.5	53.39	-51.04	7.04	-44.00	-13	-31.00
3	6846	42.93	-59.74	5.27	-54.48	-13	-41.48

Remarks:

1. Emission Value (dBm) = S.G Value (dBm) + Correction Factor (dB).
2. Correction Factor (dB) = Substitution Antenna Gain (dB) + Cable Loss (dB).

Mode	TX channel 20175	Frequency Range	Above 1000 MHz
------	------------------	-----------------	----------------

Antenna Polarity & Test Distance: Horizontal at 3 M

No.	Freq. (MHz)	Reading (dBm)	S.G Power Value (dBm)	Correction Factor (dB)	Emission Value (dBm)	Limit (dBm)	Margin (dB)
1	3465	56.4	-46.76	7.80	-38.96	-13	-25.96
2	5197.5	53.26	-51.27	7.05	-44.21	-13	-31.21
3	6930	44.37	-57.95	5.10	-52.84	-13	-39.84

Antenna Polarity & Test Distance: Vertical at 3 M

No.	Freq. (MHz)	Reading (dBm)	S.G Power Value (dBm)	Correction Factor (dB)	Emission Value (dBm)	Limit (dBm)	Margin (dB)
1	3465	49.31	-53.85	7.80	-46.05	-13	-33.05
2	5197.5	54.24	-50.29	7.05	-43.23	-13	-30.23
3	6930	43.86	-58.46	5.10	-53.35	-13	-40.35

Remarks:

1. Emission Value (dBm) = S.G Value (dBm) + Correction Factor (dB).
2. Correction Factor (dB) = Substitution Antenna Gain (dB) + Cable Loss (dB).

Mode	TX channel 20385	Frequency Range	Above 1000 MHz
------	------------------	-----------------	----------------

Antenna Polarity & Test Distance: Horizontal at 3 M

No.	Freq. (MHz)	Reading (dBm)	S.G Power Value (dBm)	Correction Factor (dB)	Emission Value (dBm)	Limit (dBm)	Margin (dB)
1	3507	57.52	-45.71	7.84	-37.86	-13	-24.86
2	5260.5	52.75	-51.87	7.07	-44.80	-13	-31.80
3	7014	43.23	-58.81	4.96	-53.85	-13	-40.85

Antenna Polarity & Test Distance: Vertical at 3 M

No.	Freq. (MHz)	Reading (dBm)	S.G Power Value (dBm)	Correction Factor (dB)	Emission Value (dBm)	Limit (dBm)	Margin (dB)
1	3507	49.49	-53.74	7.84	-45.89	-13	-32.89
2	5260.5	53.68	-50.94	7.07	-43.87	-13	-30.87
3	7014	42.53	-59.51	4.96	-54.55	-13	-41.55

Remarks:

1. Emission Value (dBm) = S.G Value (dBm) + Correction Factor (dB).
2. Correction Factor (dB) = Substitution Antenna Gain (dB) + Cable Loss (dB).

LTE Band 4: 5MHz

Mode	TX channel 19975	Frequency Range	Above 1000 MHz
------	------------------	-----------------	----------------

Antenna Polarity & Test Distance: Horizontal at 3 M

No.	Freq. (MHz)	Reading (dBm)	S.G Power Value (dBm)	Correction Factor (dB)	Emission Value (dBm)	Limit (dBm)	Margin (dB)
1	3425	57.74	-45.37	7.74	-37.63	-13	-24.63
2	5137.5	53.34	-51.10	7.04	-44.06	-13	-31.06
3	6850	44.84	-57.82	5.26	-52.56	-13	-39.56

Antenna Polarity & Test Distance: Vertical at 3 M

No.	Freq. (MHz)	Reading (dBm)	S.G Power Value (dBm)	Correction Factor (dB)	Emission Value (dBm)	Limit (dBm)	Margin (dB)
1	3425	49.48	-53.63	7.74	-45.89	-13	-32.89
2	5137.5	53.49	-50.95	7.04	-43.91	-13	-30.91
3	6850	43.25	-59.41	5.26	-54.15	-13	-41.15

Remarks:

1. Emission Value (dBm) = S.G Value (dBm) + Correction Factor (dB).
2. Correction Factor (dB) = Substitution Antenna Gain (dB) + Cable Loss (dB).

Mode	TX channel 20175	Frequency Range	Above 1000 MHz
------	------------------	-----------------	----------------

Antenna Polarity & Test Distance: Horizontal at 3 M

No.	Freq. (MHz)	Reading (dBm)	S.G Power Value (dBm)	Correction Factor (dB)	Emission Value (dBm)	Limit (dBm)	Margin (dB)
1	3465	55.94	-47.22	7.80	-39.42	-13	-26.42
2	5197.5	53.04	-51.49	7.05	-44.43	-13	-31.43
3	6930	43.6	-58.72	5.10	-53.61	-13	-40.61

Antenna Polarity & Test Distance: Vertical at 3 M

No.	Freq. (MHz)	Reading (dBm)	S.G Power Value (dBm)	Correction Factor (dB)	Emission Value (dBm)	Limit (dBm)	Margin (dB)
1	3465	49.45	-53.71	7.80	-45.91	-13	-32.91
2	5197.5	53.94	-50.59	7.05	-43.53	-13	-30.53
3	6930	42.02	-60.30	5.10	-55.19	-13	-42.19

Remarks:

1. Emission Value (dBm) = S.G Value (dBm) + Correction Factor (dB).
2. Correction Factor (dB) = Substitution Antenna Gain (dB) + Cable Loss (dB).

Mode	TX channel 20375	Frequency Range	Above 1000 MHz
------	------------------	-----------------	----------------

Antenna Polarity & Test Distance: Horizontal at 3 M

No.	Freq. (MHz)	Reading (dBm)	S.G Power Value (dBm)	Correction Factor (dB)	Emission Value (dBm)	Limit (dBm)	Margin (dB)
1	3505	56.45	-46.77	7.84	-38.92	-13	-25.92
2	5257.5	52.06	-52.56	7.07	-45.49	-13	-32.49
3	7010	44.57	-57.46	4.96	-52.50	-13	-39.50

Antenna Polarity & Test Distance: Vertical at 3 M

No.	Freq. (MHz)	Reading (dBm)	S.G Power Value (dBm)	Correction Factor (dB)	Emission Value (dBm)	Limit (dBm)	Margin (dB)
1	3505	49.26	-53.96	7.84	-46.11	-13	-33.11
2	5257.5	53.83	-50.79	7.07	-43.72	-13	-30.72
3	7010	42.04	-59.99	4.96	-55.03	-13	-42.03

Remarks:

1. Emission Value (dBm) = S.G Value (dBm) + Correction Factor (dB).
2. Correction Factor (dB) = Substitution Antenna Gain (dB) + Cable Loss (dB).

LTE Band 4: 10MHz

Mode	TX channel 20000	Frequency Range	Above 1000 MHz
------	------------------	-----------------	----------------

Antenna Polarity & Test Distance: Horizontal at 3 M

No.	Freq. (MHz)	Reading (dBm)	S.G Power Value (dBm)	Correction Factor (dB)	Emission Value (dBm)	Limit (dBm)	Margin (dB)
1	3430	56.93	-46.18	7.75	-38.44	-13	-25.44
2	5145	53.26	-51.19	7.04	-44.15	-13	-31.15
3	6860	43.65	-58.96	5.24	-53.72	-13	-40.72

Antenna Polarity & Test Distance: Vertical at 3 M

No.	Freq. (MHz)	Reading (dBm)	S.G Power Value (dBm)	Correction Factor (dB)	Emission Value (dBm)	Limit (dBm)	Margin (dB)
1	3430	49.86	-53.25	7.75	-45.51	-13	-32.51
2	5145	53.66	-50.79	7.04	-43.75	-13	-30.75
3	6860	42.26	-60.35	5.24	-55.11	-13	-42.11

Remarks:

1. Emission Value (dBm) = S.G Value (dBm) + Correction Factor (dB).
2. Correction Factor (dB) = Substitution Antenna Gain (dB) + Cable Loss (dB).

Mode	TX channel 20175	Frequency Range	Above 1000 MHz
------	------------------	-----------------	----------------

Antenna Polarity & Test Distance: Horizontal at 3 M

No.	Freq. (MHz)	Reading (dBm)	S.G Power Value (dBm)	Correction Factor (dB)	Emission Value (dBm)	Limit (dBm)	Margin (dB)
1	3465	56.38	-46.78	7.80	-38.98	-13	-25.98
2	5197.5	53.56	-50.97	7.05	-43.91	-13	-30.91
3	6930	44.79	-57.53	5.10	-52.42	-13	-39.42

Antenna Polarity & Test Distance: Vertical at 3 M

No.	Freq. (MHz)	Reading (dBm)	S.G Power Value (dBm)	Correction Factor (dB)	Emission Value (dBm)	Limit (dBm)	Margin (dB)
1	3465	49.81	-53.35	7.80	-45.55	-13	-32.55
2	5197.5	53.01	-51.52	7.05	-44.46	-13	-31.46
3	6930	43.39	-58.93	5.10	-53.82	-13	-40.82

Remarks:

1. Emission Value (dBm) = S.G Value (dBm) + Correction Factor (dB).
2. Correction Factor (dB) = Substitution Antenna Gain (dB) + Cable Loss (dB).

Mode	TX channel 20350	Frequency Range	Above 1000 MHz
------	------------------	-----------------	----------------

Antenna Polarity & Test Distance: Horizontal at 3 M

No.	Freq. (MHz)	Reading (dBm)	S.G Power Value (dBm)	Correction Factor (dB)	Emission Value (dBm)	Limit (dBm)	Margin (dB)
1	3500	57.14	-46.06	7.85	-38.21	-13	-25.21
2	5250	53.52	-51.09	7.06	-44.02	-13	-31.02
3	7000	43.32	-58.70	4.97	-53.73	-13	-40.73

Antenna Polarity & Test Distance: Vertical at 3 M

No.	Freq. (MHz)	Reading (dBm)	S.G Power Value (dBm)	Correction Factor (dB)	Emission Value (dBm)	Limit (dBm)	Margin (dB)
1	3500	50.49	-52.71	7.85	-44.86	-13	-31.86
2	5250	53.33	-51.28	7.06	-44.21	-13	-31.21
3	7000	42.77	-59.25	4.97	-54.28	-13	-41.28

Remarks:

1. Emission Value (dBm) = S.G Value (dBm) + Correction Factor (dB).
2. Correction Factor (dB) = Substitution Antenna Gain (dB) + Cable Loss (dB).

LTE Band 4: 15MHz

Mode	TX channel 20025	Frequency Range	Above 1000 MHz
------	------------------	-----------------	----------------

Antenna Polarity & Test Distance: Horizontal at 3 M

No.	Freq. (MHz)	Reading (dBm)	S.G Power Value (dBm)	Correction Factor (dB)	Emission Value (dBm)	Limit (dBm)	Margin (dB)
1	3435	57.44	-45.68	7.75	-37.93	-13	-24.93
2	5152.5	51.77	-52.69	7.04	-45.65	-13	-32.65
3	6870	43.26	-59.31	5.22	-54.09	-13	-41.09

Antenna Polarity & Test Distance: Vertical at 3 M

No.	Freq. (MHz)	Reading (dBm)	S.G Power Value (dBm)	Correction Factor (dB)	Emission Value (dBm)	Limit (dBm)	Margin (dB)
1	3435	49.81	-53.31	7.75	-45.56	-13	-32.56
2	5152.5	53.66	-50.80	7.04	-43.76	-13	-30.76
3	6870	43.43	-59.14	5.22	-53.92	-13	-40.92

Remarks:

1. Emission Value (dBm) = S.G Value (dBm) + Correction Factor (dB).
2. Correction Factor (dB) = Substitution Antenna Gain (dB) + Cable Loss (dB).

Mode	TX channel 20175	Frequency Range	Above 1000 MHz
------	------------------	-----------------	----------------

Antenna Polarity & Test Distance: Horizontal at 3 M

No.	Freq. (MHz)	Reading (dBm)	S.G Power Value (dBm)	Correction Factor (dB)	Emission Value (dBm)	Limit (dBm)	Margin (dB)
1	3465	57.53	-45.63	7.80	-37.83	-13	-24.83
2	5197.5	52.86	-51.67	7.05	-44.61	-13	-31.61
3	6930	44.33	-57.99	5.10	-52.88	-13	-39.88

Antenna Polarity & Test Distance: Vertical at 3 M

No.	Freq. (MHz)	Reading (dBm)	S.G Power Value (dBm)	Correction Factor (dB)	Emission Value (dBm)	Limit (dBm)	Margin (dB)
1	3465	50.98	-52.18	7.80	-44.38	-13	-31.38
2	5197.5	54.28	-50.25	7.05	-43.19	-13	-30.19
3	6930	42.55	-59.77	5.10	-54.66	-13	-41.66

Remarks:

1. Emission Value (dBm) = S.G Value (dBm) + Correction Factor (dB).
2. Correction Factor (dB) = Substitution Antenna Gain (dB) + Cable Loss (dB).

Mode	TX channel 20325	Frequency Range	Above 1000 MHz
------	------------------	-----------------	----------------

Antenna Polarity & Test Distance: Horizontal at 3 M

No.	Freq. (MHz)	Reading (dBm)	S.G Power Value (dBm)	Correction Factor (dB)	Emission Value (dBm)	Limit (dBm)	Margin (dB)
1	3495	56.85	-46.33	7.85	-38.48	-13	-25.48
2	5242.5	53.17	-51.42	7.06	-44.36	-13	-31.36
3	6990	43.14	-58.87	4.98	-53.89	-13	-40.89

Antenna Polarity & Test Distance: Vertical at 3 M

No.	Freq. (MHz)	Reading (dBm)	S.G Power Value (dBm)	Correction Factor (dB)	Emission Value (dBm)	Limit (dBm)	Margin (dB)
1	3495	49.57	-53.61	7.85	-45.76	-13	-32.76
2	5242.5	54.37	-50.22	7.06	-43.16	-13	-30.16
3	6990	43.68	-58.33	4.98	-53.35	-13	-40.35

Remarks:

1. Emission Value (dBm) = S.G Value (dBm) + Correction Factor (dB).
2. Correction Factor (dB) = Substitution Antenna Gain (dB) + Cable Loss (dB).

LTE Band 4: 20MHz

Mode	TX channel 20050	Frequency Range	Above 1000 MHz
------	------------------	-----------------	----------------

Antenna Polarity & Test Distance: Horizontal at 3 M

No.	Freq. (MHz)	Reading (dBm)	S.G Power Value (dBm)	Correction Factor (dB)	Emission Value (dBm)	Limit (dBm)	Margin (dB)
1	3440	57.04	-46.09	7.76	-38.33	-13	-25.33
2	5160	52.39	-52.08	7.04	-45.04	-13	-32.04
3	6880	43.27	-59.26	5.20	-54.06	-13	-41.06

Antenna Polarity & Test Distance: Vertical at 3 M

No.	Freq. (MHz)	Reading (dBm)	S.G Power Value (dBm)	Correction Factor (dB)	Emission Value (dBm)	Limit (dBm)	Margin (dB)
1	3440	50.13	-53.00	7.76	-45.24	-13	-32.24
2	5160	53.92	-50.55	7.04	-43.51	-13	-30.51
3	6880	43.29	-59.24	5.20	-54.04	-13	-41.04

Remarks:

1. Emission Value (dBm) = S.G Value (dBm) + Correction Factor (dB).
2. Correction Factor (dB) = Substitution Antenna Gain (dB) + Cable Loss (dB).

Mode	TX channel 20175	Frequency Range	Above 1000 MHz
------	------------------	-----------------	----------------

Antenna Polarity & Test Distance: Horizontal at 3 M

No.	Freq. (MHz)	Reading (dBm)	S.G Power Value (dBm)	Correction Factor (dB)	Emission Value (dBm)	Limit (dBm)	Margin (dB)
1	3465	56.84	-46.32	7.80	-38.52	-13	-25.52
2	5197.5	53.2	-51.33	7.05	-44.27	-13	-31.27
3	6930	44.04	-58.28	5.10	-53.17	-13	-40.17

Antenna Polarity & Test Distance: Vertical at 3 M

No.	Freq. (MHz)	Reading (dBm)	S.G Power Value (dBm)	Correction Factor (dB)	Emission Value (dBm)	Limit (dBm)	Margin (dB)
1	3465	49.47	-53.69	7.80	-45.89	-13	-32.89
2	5197.5	53.39	-51.14	7.05	-44.08	-13	-31.08
3	6930	43.70	-58.62	5.10	-53.51	-13	-40.51

Remarks:

1. Emission Value (dBm) = S.G Value (dBm) + Correction Factor (dB).
2. Correction Factor (dB) = Substitution Antenna Gain (dB) + Cable Loss (dB).

Mode	TX channel 20300	Frequency Range	Above 1000 MHz
------	------------------	-----------------	----------------

Antenna Polarity & Test Distance: Horizontal at 3 M

No.	Freq. (MHz)	Reading (dBm)	S.G Power Value (dBm)	Correction Factor (dB)	Emission Value (dBm)	Limit (dBm)	Margin (dB)
1	3490	56.27	-46.89	7.85	-39.04	-13	-26.04
2	5235	52.21	-52.37	7.06	-45.31	-13	-32.31
3	6980	43.9	-58.10	4.99	-53.11	-13	-40.11

Antenna Polarity & Test Distance: Vertical at 3 M

No.	Freq. (MHz)	Reading (dBm)	S.G Power Value (dBm)	Correction Factor (dB)	Emission Value (dBm)	Limit (dBm)	Margin (dB)
1	3490	49.41	-53.75	7.85	-45.90	-13	-32.90
2	5235	53.06	-51.52	7.06	-44.46	-13	-31.46
3	6980	43.02	-58.98	4.99	-53.99	-13	-40.99

Remarks:

1. Emission Value (dBm) = S.G Value (dBm) + Correction Factor (dB).
2. Correction Factor (dB) = Substitution Antenna Gain (dB) + Cable Loss (dB).

LTE Band 12: 1.4MHz

Mode	TX channel 23017	Frequency Range	Above 1000 MHz
------	------------------	-----------------	----------------

Antenna Polarity & Test Distance: Horizontal at 3 M

No.	Freq. (MHz)	Reading (dBm)	S.G Power Value (dBm)	Correction Factor (dB)	Emission Value (dBm)	Limit (dBm)	Margin (dB)
1	1399.4	56.9	-46.86	5.51	-41.35	-13	-28.35
2	2099.1	52.18	-48.31	6.85	-41.46	-13	-28.46
3	2798.8	43.49	-57.43	6.94	-50.49	-13	-37.49

Antenna Polarity & Test Distance: Vertical at 3 M

No.	Freq. (MHz)	Reading (dBm)	S.G Power Value (dBm)	Correction Factor (dB)	Emission Value (dBm)	Limit (dBm)	Margin (dB)
1	1399.4	48.28	-55.48	5.51	-49.97	-13	-36.97
2	2099.1	55.80	-44.69	6.85	-37.84	-13	-24.84
3	2798.8	40.61	-60.31	6.94	-53.37	-13	-40.37

Remarks:

1. Emission Value (dBm) = S.G Value (dBm) + Correction Factor (dB).
2. Correction Factor (dB) = Substitution Antenna Gain (dB) + Cable Loss (dB).

Mode	TX channel 23095	Frequency Range	Above 1000 MHz
------	------------------	-----------------	----------------

Antenna Polarity & Test Distance: Horizontal at 3 M

No.	Freq. (MHz)	Reading (dBm)	S.G Power Value (dBm)	Correction Factor (dB)	Emission Value (dBm)	Limit (dBm)	Margin (dB)
1	1415	56.56	-47.16	5.58	-41.58	-13	-28.58
2	2122.5	52.73	-47.64	6.84	-40.81	-13	-27.81
3	2830	43.55	-57.63	6.97	-50.66	-13	-37.66

Antenna Polarity & Test Distance: Vertical at 3 M

No.	Freq. (MHz)	Reading (dBm)	S.G Power Value (dBm)	Correction Factor (dB)	Emission Value (dBm)	Limit (dBm)	Margin (dB)
1	1415	48.99	-54.73	5.58	-49.15	-13	-36.15
2	2122.5	56.61	-43.76	6.84	-36.93	-13	-23.93
3	2830	39.73	-61.45	6.97	-54.48	-13	-41.48

Remarks:

1. Emission Value (dBm) = S.G Value (dBm) + Correction Factor (dB).
2. Correction Factor (dB) = Substitution Antenna Gain (dB) + Cable Loss (dB).

Mode	TX channel 23173	Frequency Range	Above 1000 MHz
------	------------------	-----------------	----------------

Antenna Polarity & Test Distance: Horizontal at 3 M

No.	Freq. (MHz)	Reading (dBm)	S.G Power Value (dBm)	Correction Factor (dB)	Emission Value (dBm)	Limit (dBm)	Margin (dB)
1	1430.6	57.22	-46.46	5.66	-40.80	-13	-27.80
2	2145.9	52.08	-48.17	6.83	-41.35	-13	-28.35
3	2861.2	42.95	-58.49	7.00	-51.49	-13	-38.49

Antenna Polarity & Test Distance: Vertical at 3 M

No.	Freq. (MHz)	Reading (dBm)	S.G Power Value (dBm)	Correction Factor (dB)	Emission Value (dBm)	Limit (dBm)	Margin (dB)
1	1430.6	49.21	-54.47	5.66	-48.81	-13	-35.81
2	2145.9	56.06	-44.19	6.83	-37.37	-13	-24.37
3	2861.2	40.51	-60.93	7.00	-53.93	-13	-40.93

Remarks:

1. Emission Value (dBm) = S.G Value (dBm) + Correction Factor (dB).
2. Correction Factor (dB) = Substitution Antenna Gain (dB) + Cable Loss (dB).

LTE Band 12: 3MHz

Mode	TX channel 23025	Frequency Range	Above 1000 MHz
------	------------------	-----------------	----------------

Antenna Polarity & Test Distance: Horizontal at 3 M

No.	Freq. (MHz)	Reading (dBm)	S.G Power Value (dBm)	Correction Factor (dB)	Emission Value (dBm)	Limit (dBm)	Margin (dB)
1	1401	57.5	-46.26	5.52	-40.74	-13	-27.74
2	2101.5	51.44	-49.04	6.85	-42.19	-13	-29.19
3	2802	44.25	-56.70	6.94	-49.76	-13	-36.76

Antenna Polarity & Test Distance: Vertical at 3 M

No.	Freq. (MHz)	Reading (dBm)	S.G Power Value (dBm)	Correction Factor (dB)	Emission Value (dBm)	Limit (dBm)	Margin (dB)
1	1401	48.41	-55.35	5.52	-49.83	-13	-36.83
2	2101.5	55.33	-45.15	6.85	-38.30	-13	-25.30
3	2802	40.44	-60.51	6.94	-53.57	-13	-40.57

Remarks:

1. Emission Value (dBm) = S.G Value (dBm) + Correction Factor (dB).
2. Correction Factor (dB) = Substitution Antenna Gain (dB) + Cable Loss (dB).

Mode	TX channel 23095	Frequency Range	Above 1000 MHz
------	------------------	-----------------	----------------

Antenna Polarity & Test Distance: Horizontal at 3 M

No.	Freq. (MHz)	Reading (dBm)	S.G Power Value (dBm)	Correction Factor (dB)	Emission Value (dBm)	Limit (dBm)	Margin (dB)
1	1415	56.15	-47.57	5.58	-41.99	-13	-28.99
2	2122.5	52	-48.37	6.84	-41.54	-13	-28.54
3	2830	43.85	-57.33	6.97	-50.36	-13	-37.36

Antenna Polarity & Test Distance: Vertical at 3 M

No.	Freq. (MHz)	Reading (dBm)	S.G Power Value (dBm)	Correction Factor (dB)	Emission Value (dBm)	Limit (dBm)	Margin (dB)
1	1415	49.14	-54.58	5.58	-49.00	-13	-36.00
2	2122.5	56.79	-43.58	6.84	-36.75	-13	-23.75
3	2830	41.54	-59.64	6.97	-52.67	-13	-39.67

Remarks:

1. Emission Value (dBm) = S.G Value (dBm) + Correction Factor (dB).
2. Correction Factor (dB) = Substitution Antenna Gain (dB) + Cable Loss (dB).

Mode	TX channel 23165	Frequency Range	Above 1000 MHz
------	------------------	-----------------	----------------

Antenna Polarity & Test Distance: Horizontal at 3 M

No.	Freq. (MHz)	Reading (dBm)	S.G Power Value (dBm)	Correction Factor (dB)	Emission Value (dBm)	Limit (dBm)	Margin (dB)
1	1429	57.82	-45.86	5.65	-40.21	-13	-27.21
2	2143.5	53.13	-47.14	6.83	-40.31	-13	-27.31
3	2858	43.09	-58.32	7.00	-51.33	-13	-38.33

Antenna Polarity & Test Distance: Vertical at 3 M

No.	Freq. (MHz)	Reading (dBm)	S.G Power Value (dBm)	Correction Factor (dB)	Emission Value (dBm)	Limit (dBm)	Margin (dB)
1	1429	48.22	-55.46	5.65	-49.81	-13	-36.81
2	2143.5	55.68	-44.59	6.83	-37.76	-13	-24.76
3	2858	40.39	-61.02	7.00	-54.03	-13	-41.03

Remarks:

1. Emission Value (dBm) = S.G Value (dBm) + Correction Factor (dB).
2. Correction Factor (dB) = Substitution Antenna Gain (dB) + Cable Loss (dB).

LTE Band 12: 5MHz

Mode	TX channel 23035	Frequency Range	Above 1000 MHz
------	------------------	-----------------	----------------

Antenna Polarity & Test Distance: Horizontal at 3 M

No.	Freq. (MHz)	Reading (dBm)	S.G Power Value (dBm)	Correction Factor (dB)	Emission Value (dBm)	Limit (dBm)	Margin (dB)
1	1403	57.87	-45.88	5.53	-40.36	-13	-27.36
2	2104.5	52.72	-47.74	6.85	-40.90	-13	-27.90
3	2806	42.55	-58.43	6.94	-51.49	-13	-38.49

Antenna Polarity & Test Distance: Vertical at 3 M

No.	Freq. (MHz)	Reading (dBm)	S.G Power Value (dBm)	Correction Factor (dB)	Emission Value (dBm)	Limit (dBm)	Margin (dB)
1	1403	48.39	-55.36	5.53	-49.84	-13	-36.84
2	2104.5	56.36	-44.10	6.85	-37.26	-13	-24.26
3	2806	41.29	-59.69	6.94	-52.75	-13	-39.75

Remarks:

1. Emission Value (dBm) = S.G Value (dBm) + Correction Factor (dB).
2. Correction Factor (dB) = Substitution Antenna Gain (dB) + Cable Loss (dB).

Mode	TX channel 23095	Frequency Range	Above 1000 MHz
------	------------------	-----------------	----------------

Antenna Polarity & Test Distance: Horizontal at 3 M

No.	Freq. (MHz)	Reading (dBm)	S.G Power Value (dBm)	Correction Factor (dB)	Emission Value (dBm)	Limit (dBm)	Margin (dB)
1	1415	56.13	-47.59	5.58	-42.01	-13	-29.01
2	2122.5	51.43	-48.94	6.84	-42.11	-13	-29.11
3	2830	42.97	-58.21	6.97	-51.24	-13	-38.24

Antenna Polarity & Test Distance: Vertical at 3 M

No.	Freq. (MHz)	Reading (dBm)	S.G Power Value (dBm)	Correction Factor (dB)	Emission Value (dBm)	Limit (dBm)	Margin (dB)
1	1415	48.45	-55.27	5.58	-49.69	-13	-36.69
2	2122.5	55.21	-45.16	6.84	-38.33	-13	-25.33
3	2830	40.20	-60.98	6.97	-54.01	-13	-41.01

Remarks:

1. Emission Value (dBm) = S.G Value (dBm) + Correction Factor (dB).
2. Correction Factor (dB) = Substitution Antenna Gain (dB) + Cable Loss (dB).

Mode	TX channel 23155	Frequency Range	Above 1000 MHz
------	------------------	-----------------	----------------

Antenna Polarity & Test Distance: Horizontal at 3 M

No.	Freq. (MHz)	Reading (dBm)	S.G Power Value (dBm)	Correction Factor (dB)	Emission Value (dBm)	Limit (dBm)	Margin (dB)
1	1427	57.77	-45.92	5.64	-40.28	-13	-27.28
2	2140.5	51.43	-48.85	6.83	-42.02	-13	-29.02
3	2854	43.15	-58.23	6.99	-51.24	-13	-38.24

Antenna Polarity & Test Distance: Vertical at 3 M

No.	Freq. (MHz)	Reading (dBm)	S.G Power Value (dBm)	Correction Factor (dB)	Emission Value (dBm)	Limit (dBm)	Margin (dB)
1	1427	48.36	-55.33	5.64	-49.69	-13	-36.69
2	2140.5	56.37	-43.91	6.83	-37.08	-13	-24.08
3	2854	41.19	-60.19	6.99	-53.20	-13	-40.20

Remarks:

1. Emission Value (dBm) = S.G Value (dBm) + Correction Factor (dB).
2. Correction Factor (dB) = Substitution Antenna Gain (dB) + Cable Loss (dB).

LTE Band 12: 10MHz

Mode	TX channel 23060	Frequency Range	Above 1000 MHz
------	------------------	-----------------	----------------

Antenna Polarity & Test Distance: Horizontal at 3 M

No.	Freq. (MHz)	Reading (dBm)	S.G Power Value (dBm)	Correction Factor (dB)	Emission Value (dBm)	Limit (dBm)	Margin (dB)
1	1408	56.77	-46.97	5.55	-41.42	-13	-28.42
2	2112	53.01	-47.42	6.84	-40.57	-13	-27.57
3	2816	42.71	-58.35	6.95	-51.40	-13	-38.40

Antenna Polarity & Test Distance: Vertical at 3 M

No.	Freq. (MHz)	Reading (dBm)	S.G Power Value (dBm)	Correction Factor (dB)	Emission Value (dBm)	Limit (dBm)	Margin (dB)
1	1408	47.33	-56.41	5.55	-50.86	-13	-37.86
2	2112	55.00	-45.43	6.84	-38.58	-13	-25.58
3	2816	39.65	-61.41	6.95	-54.46	-13	-41.46

Remarks:

1. Emission Value (dBm) = S.G Value (dBm) + Correction Factor (dB).
2. Correction Factor (dB) = Substitution Antenna Gain (dB) + Cable Loss (dB).

Mode	TX channel 23095	Frequency Range	Above 1000 MHz
------	------------------	-----------------	----------------

Antenna Polarity & Test Distance: Horizontal at 3 M

No.	Freq. (MHz)	Reading (dBm)	S.G Power Value (dBm)	Correction Factor (dB)	Emission Value (dBm)	Limit (dBm)	Margin (dB)
1	1415	56.71	-47.01	5.58	-41.43	-13	-28.43
2	2122.5	51.2	-49.17	6.84	-42.34	-13	-29.34
3	2830	42.69	-58.49	6.97	-51.52	-13	-38.52

Antenna Polarity & Test Distance: Vertical at 3 M

No.	Freq. (MHz)	Reading (dBm)	S.G Power Value (dBm)	Correction Factor (dB)	Emission Value (dBm)	Limit (dBm)	Margin (dB)
1	1415	48.52	-55.20	5.58	-49.62	-13	-36.62
2	2122.5	55.58	-44.79	6.84	-37.96	-13	-24.96
3	2830	41.08	-60.10	6.97	-53.13	-13	-40.13

Remarks:

1. Emission Value (dBm) = S.G Value (dBm) + Correction Factor (dB).
2. Correction Factor (dB) = Substitution Antenna Gain (dB) + Cable Loss (dB).

Mode	TX channel 23130	Frequency Range	Above 1000 MHz
------	------------------	-----------------	----------------

Antenna Polarity & Test Distance: Horizontal at 3 M

No.	Freq. (MHz)	Reading (dBm)	S.G Power Value (dBm)	Correction Factor (dB)	Emission Value (dBm)	Limit (dBm)	Margin (dB)
1	1422	57.65	-46.05	5.62	-40.43	-13	-27.43
2	2133	51.52	-48.80	6.83	-41.97	-13	-28.97
3	2844	43.56	-57.74	6.98	-50.75	-13	-37.75

Antenna Polarity & Test Distance: Vertical at 3 M

No.	Freq. (MHz)	Reading (dBm)	S.G Power Value (dBm)	Correction Factor (dB)	Emission Value (dBm)	Limit (dBm)	Margin (dB)
1	1422	48.14	-55.56	5.62	-49.94	-13	-36.94
2	2133	56.38	-43.94	6.83	-37.11	-13	-24.11
3	2844	40.75	-60.55	6.98	-53.56	-13	-40.56

Remarks:

1. Emission Value (dBm) = S.G Value (dBm) + Correction Factor (dB).
2. Correction Factor (dB) = Substitution Antenna Gain (dB) + Cable Loss (dB).

5 Pictures of Test Arrangements

Please refer to the attached file (Test Setup Photo).

Appendix – Information of the Testing Laboratories

We, Bureau Veritas Consumer Products Services (H.K.) Ltd., Taoyuan Branch, were founded in 1988 to provide our best service in EMC, Radio, Telecom and Safety consultation. Our laboratories are accredited and approved according to ISO/IEC 17025.

If you have any comments, please feel free to contact us at the following:

Lin Kou EMC/RF Lab

Tel: 886-2-26052180

Fax: 886-2-26051924

Hsin Chu EMC/RF Lab/Telecom Lab

Tel: 886-3-6668565

Fax: 886-3-6668323

Hwa Ya EMC/RF/Safety

Tel: 886-3-3183232

Fax: 886-3-3270892

Email: service.adt@tw.bureauveritas.com

Web Site: www.bureauveritas-adt.com

The address and road map of all our labs can be found in our web site also.

--- END ---