

blacklinesafety

Alert. Locate. Respond.

Loner 3G Bridge Radio Frequency (RF) Exposure Compliance

1 Document Revision History

Revision	Date	Author	Summary
1	Dec 19, 2016	Scott Jacobsen	Initial release

2 Purpose of this Report

The purpose of this report is to show the radio frequency (RF) exposure compliance of certain simultaneous transmission configurations of the modules inside the product named Loner Bridge.

3 Identifiers

3.1 Host Product

Internal Product Name: Loner 3G Bridge

Model: 102313

3.2 Module Identifiers

Module Description	Model	FCC ID	IC ID	Grantee
Cellular	SARA-U201	XPY1CGM5NNN	8595A-1CGM5NNN	u-blox AG
Satellite	9603	Q639603	4629A-9603	Iridium Satellite LLC
Frequency Hopping Transceiver	MLINK G 900A FW	KQNMLINK900	2361A-MLINK900	Murandi Communications Ltd

3.3 Antennas

Frequency Band	Vendor	Model	Peak Gain(dBi)	Data Sheet Reference
Cellular	Murandi Communications	Bridge Cellular Antenna	0.5	Appendix A
PCS	Murandi Communications	Bridge Cellular Antenna	1.5	Appendix A

Satellite	Taoglas	IP.1621.25.4.A.02	3.0	Appendix B
915 MHz ISM	Murandi Communications	MLink Antenna	2.4	Appendix C

4 Module Technical Details

Technology	Frequency Band	Lowest transmit frequency (MHz)	Highest transmit frequency (MHz)	Kind of modulation	Power Class	Tested power control level	GPRS/EGPRS mobile station class	GPRS/EGPRS multislots class	Maximum output power (dBm)	Frame Length (ms)	Slot Length (ms)	Number of Slots used for Transmissions	Duty Cycle (percent)
GSM	Cellular	824.2	848.8	GMSK	4	5	B	8	32.6	4.615	0.577	2	25
GSM	PCS	1850.2	1909.8	GMSK	1	0	B	8	29.8	4.615	0.577	2	25
UMTS	Cellular	824.2	848.8	WCDMA	N/A	24	N/A	N/A	24.1	N/A	N/A	N/A	100
UMTS	PCS	1850.2	1909.8	WCDMA	N/A	24	N/A	N/A	23.6	N/A	N/A	N/A	100
Satellite	L-Band	1616	1626	QPSK	N/A	N/A	N/A	N/A	34.39	90	8.28	1	9.2
FHSS	ISM	903	927	BPSK	N/A	N/A	N/A	N/A	29.0	N/A	N/A	N/A	50

5 Test Standards

Test Standard	Version	Test Standard Description
FCC 47 CFR 2.1091	e-CFR June 2, 2014	Radiofrequency radiation exposure evaluation: mobile devices.
RSS-102	Issue 4, March 2010	6 Radio Frequency (RF) Exposure Compliance of Radiocommunication Apparatus (All Frequency Bands)

6 Limits

6.1 FCC and IC Limits for General Population/Uncontrolled Exposure

Frequency Range	E-field strength (V/m)	H-field strength (A/m)	B-field strength (μ T)	Power density (mW/cm ²)
300 – 1500 MHz	--	--	--	f(MHz) / 1500
1.5 – 100 GHz	--	--	--	1.0

6.2 Limits for Categorical Exclusion from Routine Evaluation

Frequency Range	FCC Specification	IC Specification
Below 1.5 GHz	EIRP < 1.5 W	EIRP < 2.5 W
Above 1.5 GHz	EIRP < 3 W	EIRP < 5 W

7 RF Exposure Assessment

7.1 Maximum permissible exposure (MPE)

Fixed/mobile exposure conditions of multiple transmitters installed in different hosts represent the most difficult situation in terms of the determination of minimum safety distances. While EMF measurements most often only refer to a single configuration with only one transmitter or with multiple co-located transmitters a general approach is needed to determine a worst case condition under which several transmitters and their antennas can be installed to prevent additional RF exposure evaluation for each host.

This test report illustrates how three specific radio modules can be integrated in a host without the need of further testing.

The background of the calculation is a minimum distance of 20 cm between antenna(s) and user (mobile exposure condition), and the compliance with the requirements of section 5.

7.2 Formulas

1. Average power density for each transmitter at a distance of 20 cm, S_{eq} , is calculated using the following formula:

$$S_{eq} = \frac{P \cdot G}{4\pi \cdot r^2} \times \eta$$

where

P is the peak power conducted into the antenna

G is the peak antenna gain

η is the duty cycle of transmissions

R = 20 cm

2. Then the ratio S_{eq}/S_{lim} is calculated for all applied limits, where S_{lim} is the limit at the frequency of interest, as specified in section 6. This essentially converts the power densities into unit-less values representing the portion of the power density limit generated by individual transmitters.
3. Finally, it must be ensured that the sum of all worst case power densities of all active transmitters do not exceed the limits, even if they are far below the limits for the single transmitter. The ratios for all the transmitters calculated in step 2 are summed together in all possible combinations of transmitters such that

$$\sum_1^n \frac{S_{eq\ n}}{S_{lim\ n}} = \frac{S_{eq\ 1}}{S_{lim\ 1}} + \frac{S_{eq\ 2}}{S_{lim\ 2}} + \dots + \frac{S_{eq\ n}}{S_{lim\ n}} \leq 1$$

7.3 Individual Radiated Power Densities

Module	Frequency (MHz)	Conducted Output Power (mW)	Conducted Output Power (dBm)	Antenna Gain (dBi)	Antenna Gain (linear)	EIRP (dBm)	EIRP (mW)	Duty Cycle (%)	S _{eq} - Average Power Density (mW/cm ²)	S _{lim} - Power Density Limit (mW/cm ²)	Portion of Limit
GSM850	824.2	1819	32.4	0.5	1.12	33.1	2041	25	0.10	0.55	0.1847
PCS1900	1850.2	955	29.8	1.5	1.41	31.3	1349	25	0.07	1.00	0.0671
WCDMA850	824.2	259	24.1	0.5	1.12	24.6	291	100	0.06	0.55	0.1052
WCDMA1900	1850.2	229	23.6	1.5	1.41	25.1	323	100	0.06	1.00	0.0644
Satellite	1616	1410	31.5	3.0	2.00	34.5	2813	9.2	0.05	1.00	0.0515
915 ISM	903	800	29.0	2.4	1.74	31.4	1390	50	0.14	0.60	0.2297

7.4 Total Radiated Power Densities from Transmitter Combinations

- A. GSM 850, Satellite, 915 MHz ISM

$$0.1847 + 0.0515 + 0.2297 = \mathbf{0.4724}$$

- B. PCS1800, Satellite, 915 MHz ISM

$$0.0671 + 0.0515 + 0.2297 = \mathbf{0.3548}$$

- C. WCDMA 850, Satellite, 915 MHz ISM

$$0.1052 + 0.0515 + 0.2297 = \mathbf{0.3929}$$

- D. WCDMA 1900, Satellite, 915 MHz ISM

$$0.0644 + 0.0515 + 0.2297 = \mathbf{0.3521}$$

The summations of the individual radiated power density portions for the two transmitter combinations are both less than 1.0, and hence the total radiated power density from the Loner Bridge is deemed to be compliant with the regulatory requirements.

8 Statement of Compliance

The electromagnetic field (EMF) values found for the co-located modules of Loner Bridge are below the maximum allowed levels according to the standards listed in section 5 when used with the antennas specified in section 3.3.

Appendix A: Bridge Cellular Antenna

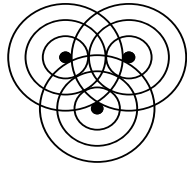

Murandi
Communications Ltd.
Innovative Radio Frequency Solutions

Bridge Cellular Antenna Datasheet

Revision – Draft

May 21, 2014

Murandi Communications Ltd.

106, 4715 - 13th St. NE, Calgary, Alberta, Canada, T2E 6M3

Tel: (403) 777-9988

email murandi@murandi.com

Fax: (403) 777-9989

www.murandi.com

Confidential and Proprietary

Table of Contents

1	REVISION HISTORY	2
2	ABBREVIATIONS.....	2
3	INTRODUCTION.....	3
4	ANTENNA SPECIFICATION.....	3

1 Revision History

Revision	Date	Description
Draft	May 21, 2014	Initial release

2 Abbreviations

Abbreviation	Description
Attn	attenuator
BW	bandwidth
dB	decibel
dBc	decibel relative to carrier power
dB _i	decibel relative to an isotropic antenna
dBm	decibel relative to 1 milliwatt
FCC	federal communications commission
FHSS	frequency hopping spread spectrum
GPS	global positioning system
IC	Industry Canada
ISM	industrial, scientific and medical
ISR	interrupt service routine
kHz	kilohertz
LCD	liquid crystal display
LED	light emitting diode
LNA	low noise amplifier
mA	milliampere
mcd	millicandle
MHz	mega-hertz
mm	millimeter
msec	millisecond
mV	millivolt
PA	power amplifier
PLL	phase locked loop
ppm	parts per million
RBW	resolution bandwidth
RF	radio frequency
RTC	Real time clock
TBC	to be confirmed
TBD	to be determined
TRP	total radiated power
μA	microampere
TDD	Time division duplex

Murandi Communications Ltd.

106, 4715 - 13th St. NE, Calgary, Alberta, Canada, T2E 6M3

Tel: (403) 777-9988

email murandi@murandi.com

Fax: (403) 777-9989

www.murandi.com

Confidential and Proprietary

Abbreviation	Description
UART	universal asynchronous receiver/transmitter
V	volts
W	width

3 Introduction

This document contains the Antenna Specifications for the Bridge Cellular integral antenna.

4 Antenna Specification

Subject	Specification	Comments
Frequency Range		
GSM 850		
Uplink	824 MHz – 849 MHz	
Downlink	869 MHz – 894 MHz	
PCS 1900		
Uplink	1850 MHz – 1910 MHz	
Downlink	1930 MHz – 1990 MHz	
Peak Gain		
GSM 850	+0.5 dBi max	
PCS 1900	+1.5 dBi max	

Typical performance:



Total Radiated power: -12.01 dBm
Efficiency -2.95 dB

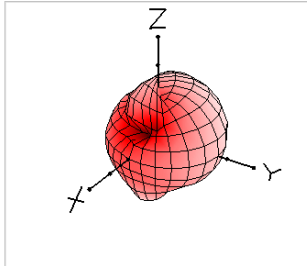

Vertical Polarization
 Vert. Component: -14.01 dBm
 Peak Gain: 0.01 dBi
 Theta 165, Phi 180

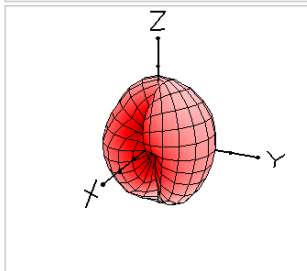

Horizontal Polarization
 Horz. Component: -16.34 dBm
 Peak Gain: 0.17 dBi
 Theta 165, Phi 270

File Name: Cell Antenna 894MHz with new match all modules no housing
 Tx Power: -9.06 dBm Measured
 Frequency: 893.80 MHz
 Cable Attenuation: 1.34 dB

Tue, Nov 26, 2013 6:30 PM
 Receive Antenna Gain: 1.65 dBi
 Separation: 1.16 m



Total Radiated power: -9.07 dBm
Efficiency -3.54 dB

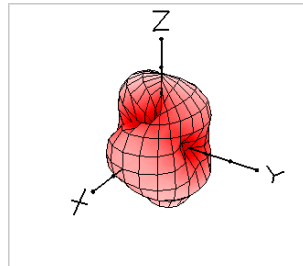

Vertical Polarization
 Vert. Component: -10.71 dBm
 Peak Gain: 1.00 dBi
 Theta 165, Phi 60

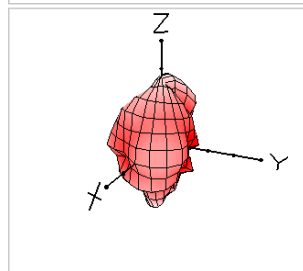

Horizontal Polarization
 Horz. Component: -14.11 dBm
 Peak Gain: -0.32 dBi
 Theta 165, Phi 345

File Name: Cell Antenna 1850MHz with new match2 all modules no housing
 Tx Power: -5.53 dBm Measured
 Frequency: 1849.70 MHz
 Cable Attenuation: 2.10 dB

Thu, Nov 28, 2013 10:48 AM
 Receive Antenna Gain: 1.65 dBi
 Separation: 1.22 m

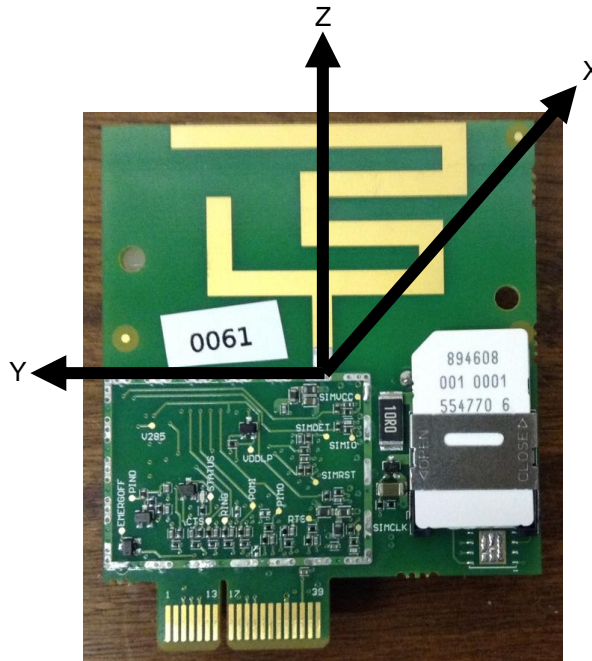

Antenna Orientation

Appendix B: Taoglas Satellite Antenna

SPECIFICATION

Iridium Certified

Part No. : **IP.1621.25.4.A.02**

Product Name : **4mm thick Iridium Patch Antenna, 1621MHz**

Features : 25mm*25mm*4mm
ROHS Compliant

:



1. Introduction

This miniaturized ceramic Iridium patch antenna is based on smart **XtremeGain™** technology. It is mounted via pin and double-sided adhesive and has been selected as optimal solution for the customer device environment. Iridium certifies the IP.1621.25.4.A.02 for commercial use in connection with the Iridium Communications systems.

2. Key Antenna Performance Indicators

Original Patch Specification tested on 50*50mm ground plane

No	Parameter	Specification	Notes
1	Range of Receiving Frequency	1616~1626.5Mhz	
2	Center Frequency	1621MHz ±3MHz	with 50*50mm GND Plane
3	Bandwidth	16MHz	Return Loss ≤-10dB
4	VSWR	1.5 max	Center Frequency
5	Gain at Zenith	+2.0dBi typ.	Center Frequency
6	Gain at 10° Elevation	--	Center Frequency
7	Axial Ratio	3 dB Max	Center Frequency
8	Polarization	RHCP	
9	Impedance	50Ω	
10	Frequency Temp Coefficient (Tf)	0±20ppm/°C	-40°C to +85°C
11	Operating Temperature	-40°C to +85°C	
12	Antenna Weight	10g	

3. Mechanical Specifications

3.1 Shape and Dimension

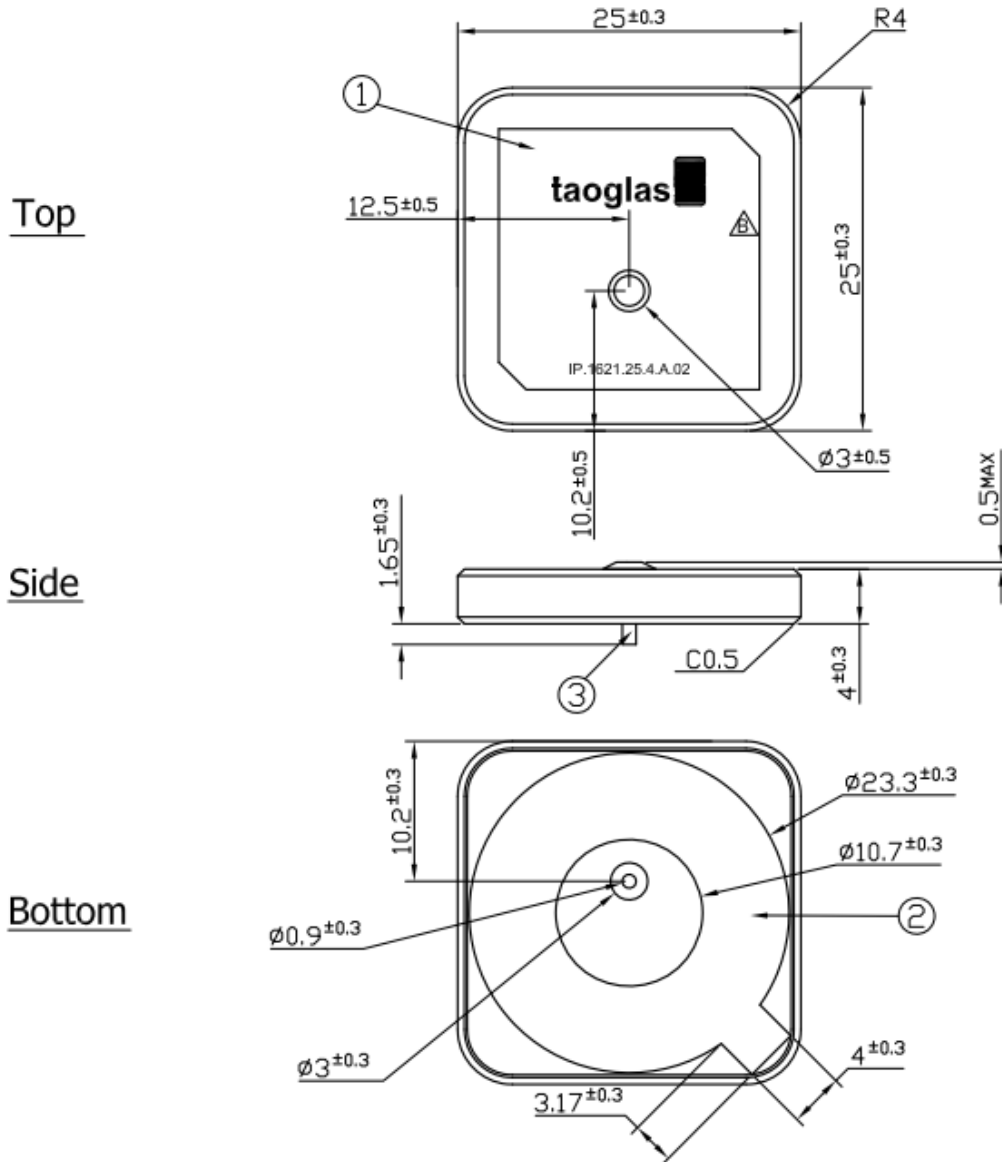

	Name	Material	Finish	QTY
1	IP.25A Iridium Patch (25x25x4mm)	Ceramic	Clear	1
2	Double sided Adhesive	NITTO 5015	White Liner	1
3	Pin	Brass	Tin Plated	1

3.2 Layout

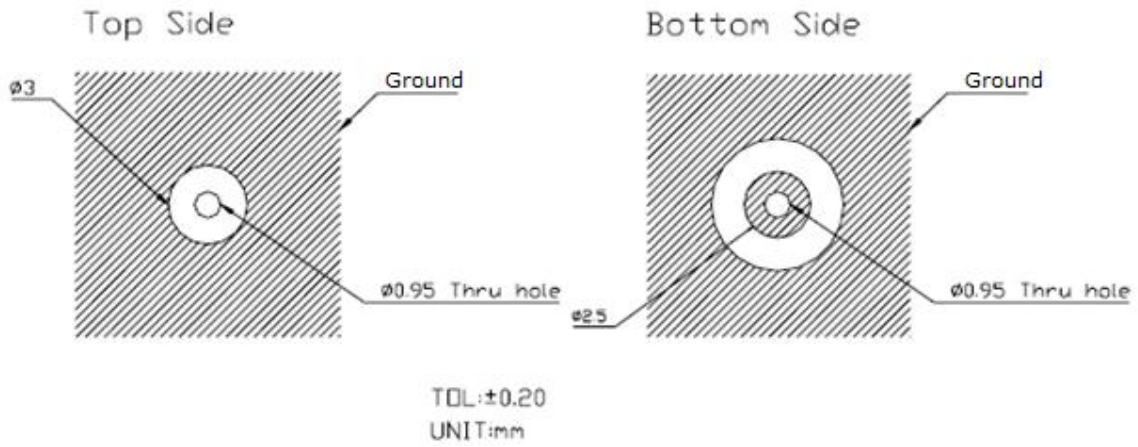

3.3 Mark

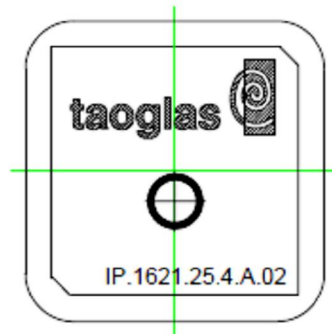

3.4 Test Jig and Dimensions

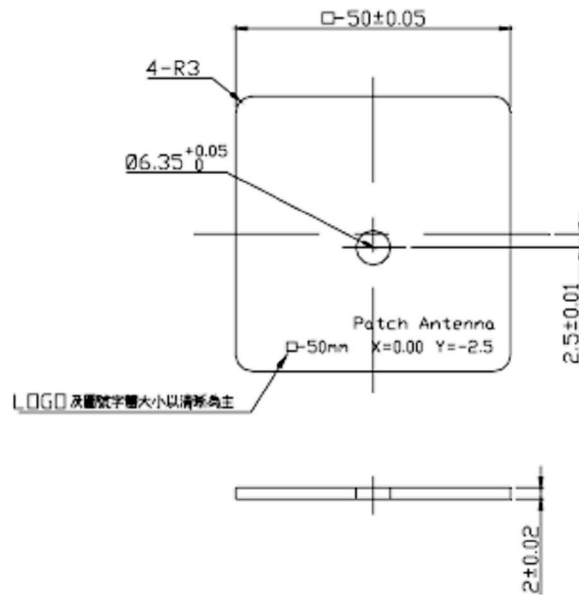

3.5 Test Fixture Antenna Setup and Measurements

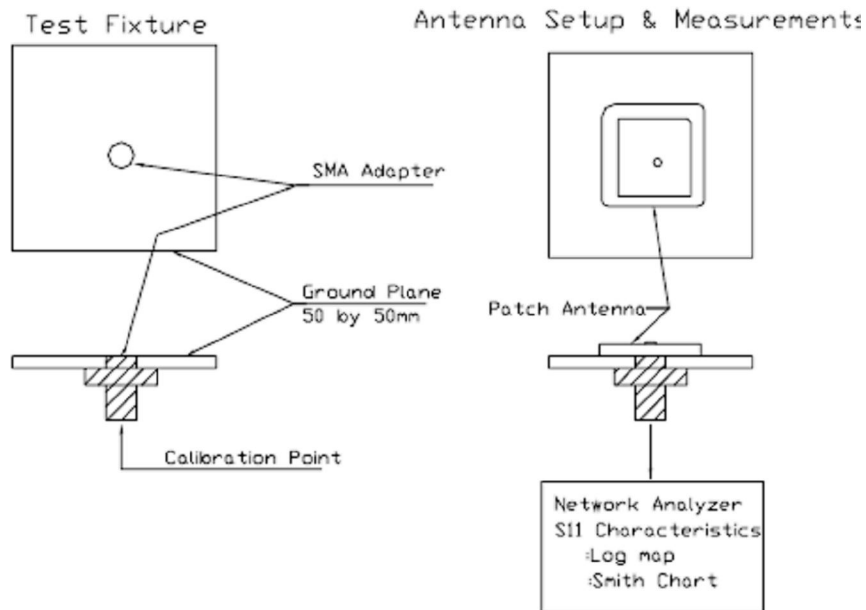

4. Performance testing and results

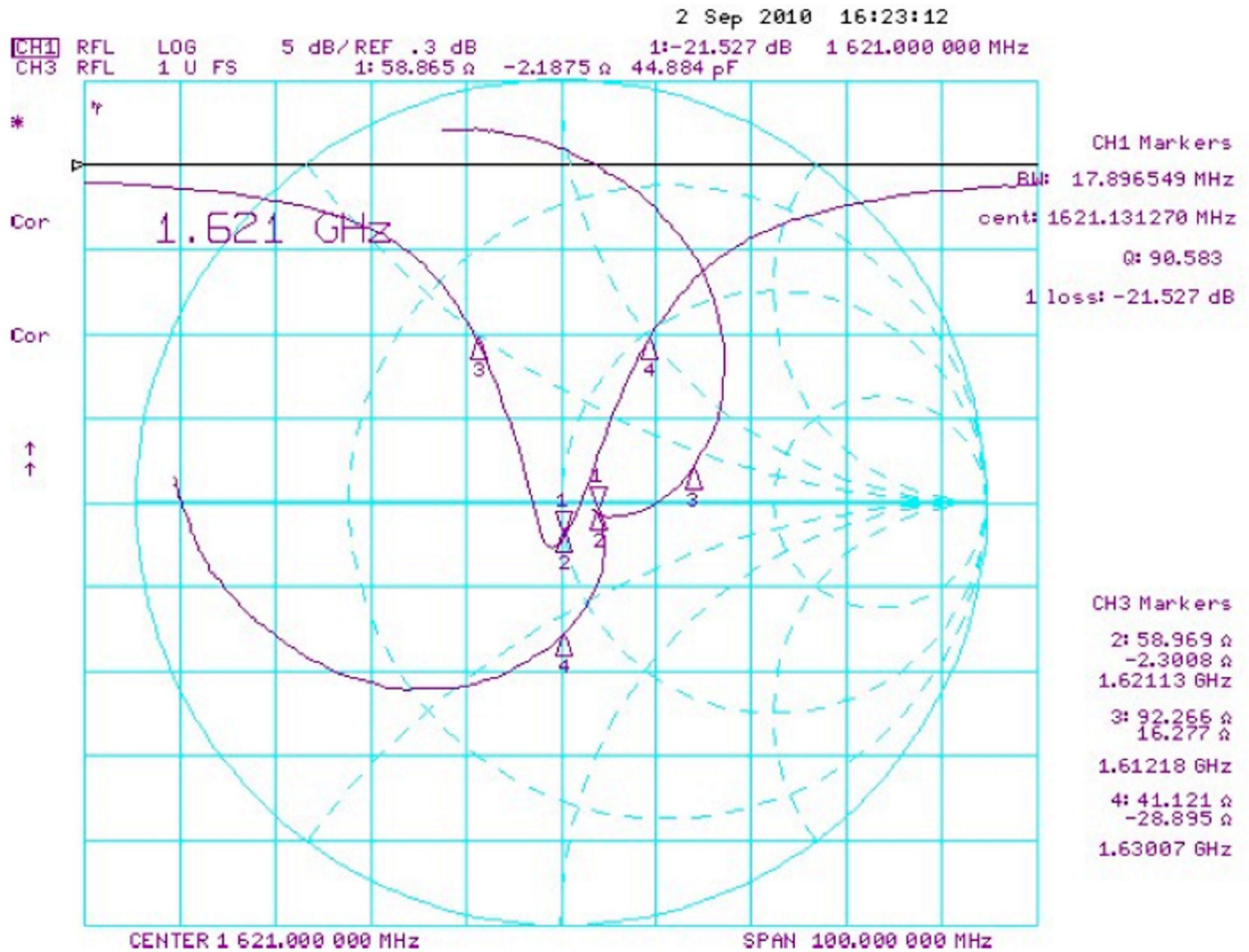

Antenna Gain Chart

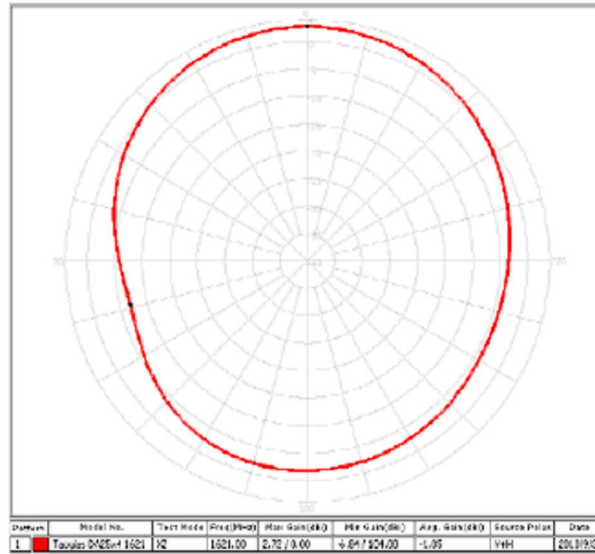

XZ-Plane

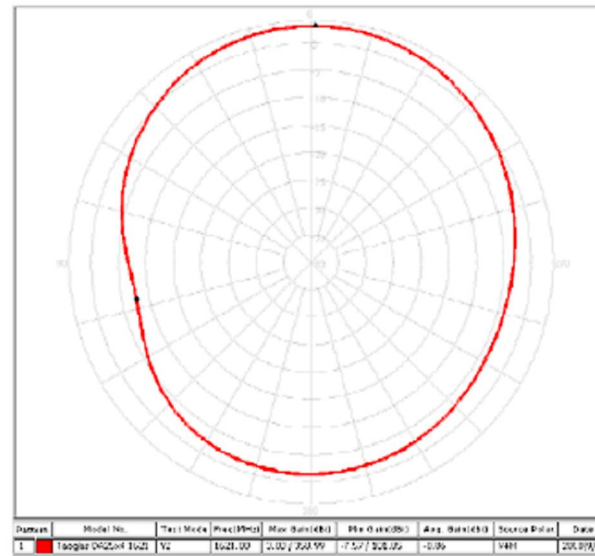

YZ-Plane

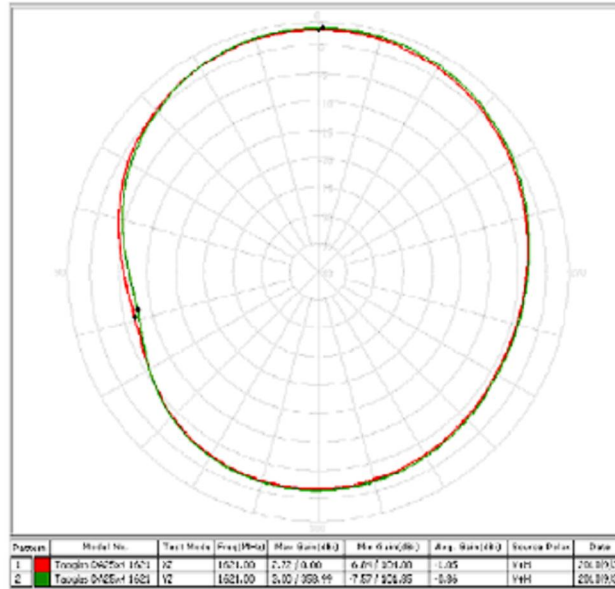

XZ+YZ-Plane

Plane	Max Gain(dBi)	Min Gain(dBi)	Avg. Gain(dBi)
XZ	2.72/1.00	-6.84/104	-1.05
YZ	3.00/358.99	-7.57/101.85	-0.86

Axial Ratio

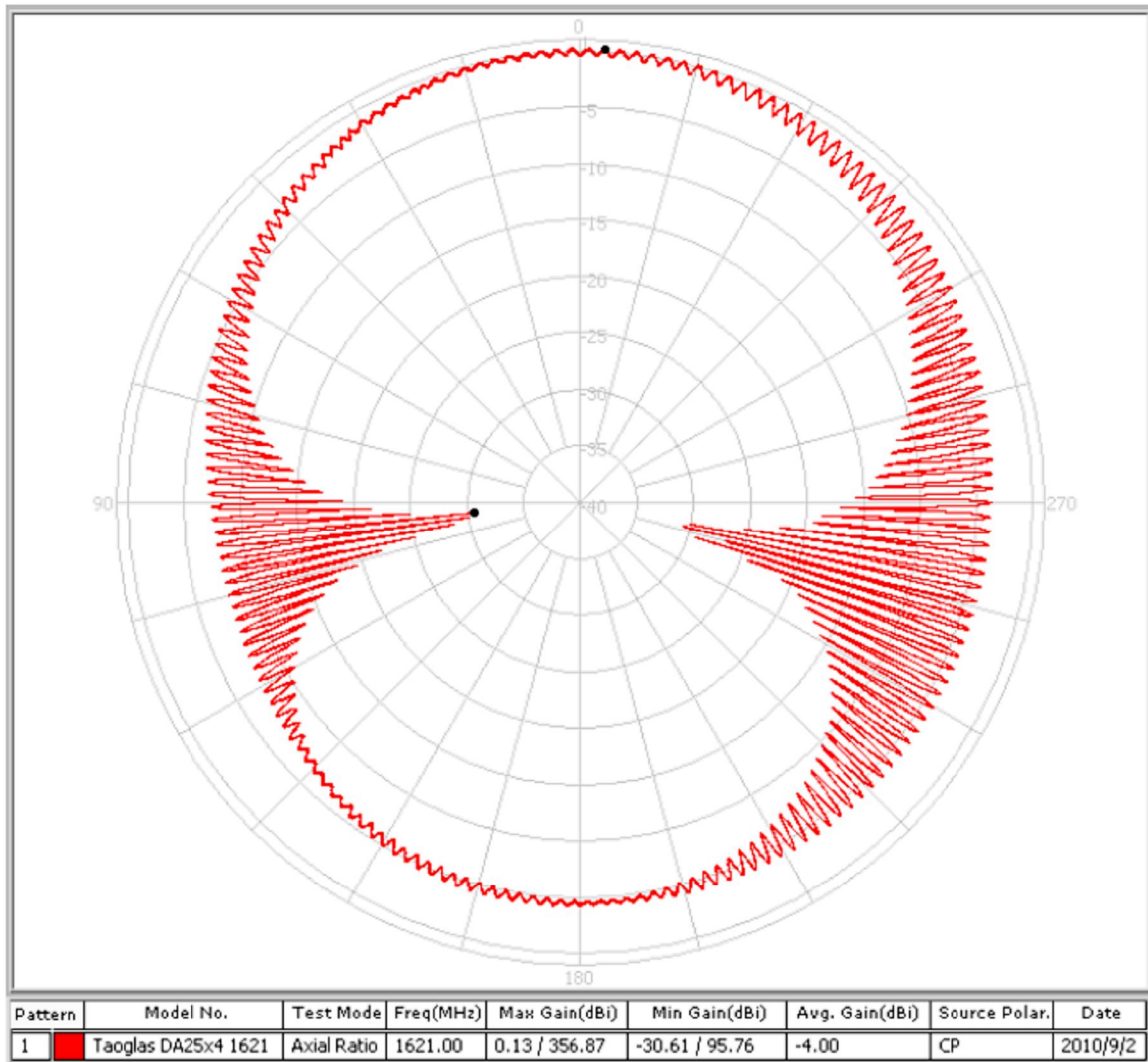

5. Packaging

- Per Tray: 50 pieces
- Per Carton(Inside Box) . 4 Trays = 200 pieces
- Outer Carton (Outside Box). 4 Cartons = 800 pieces

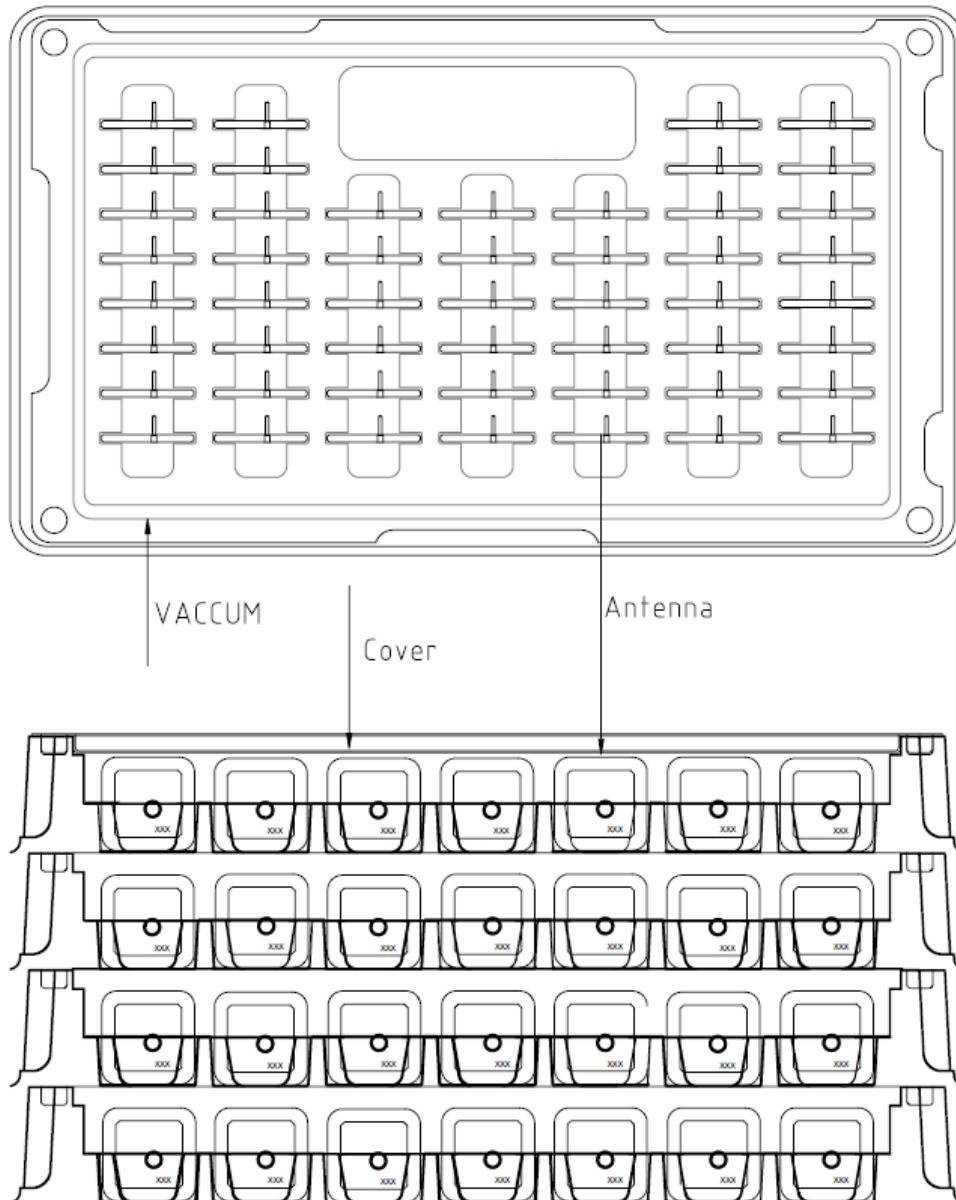

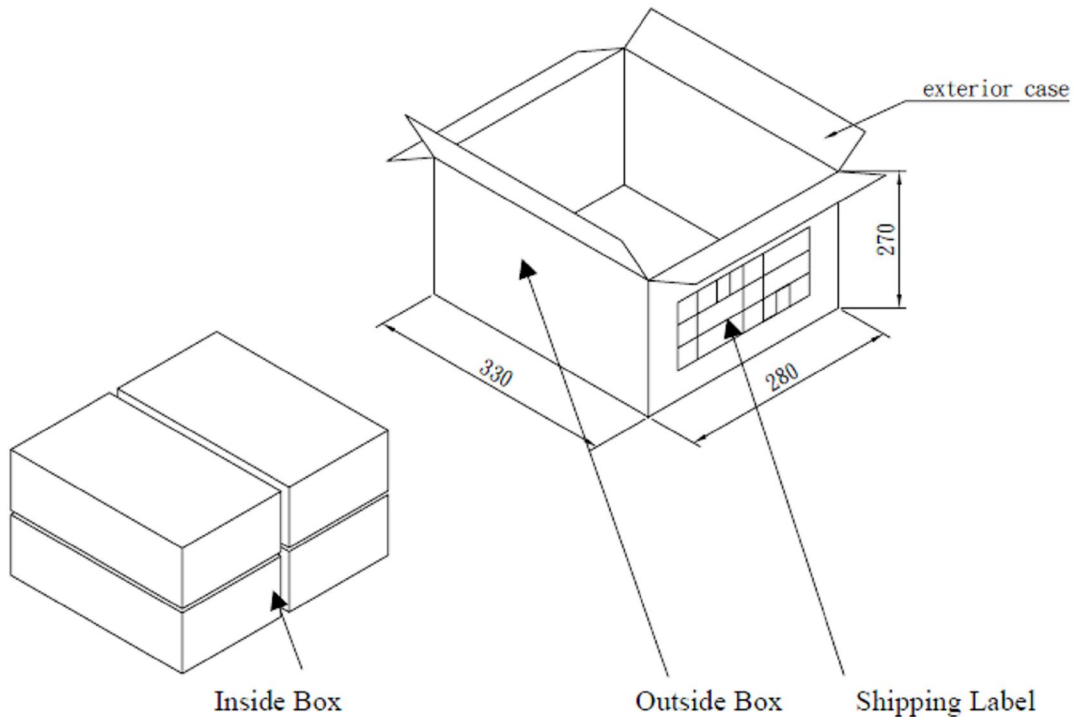
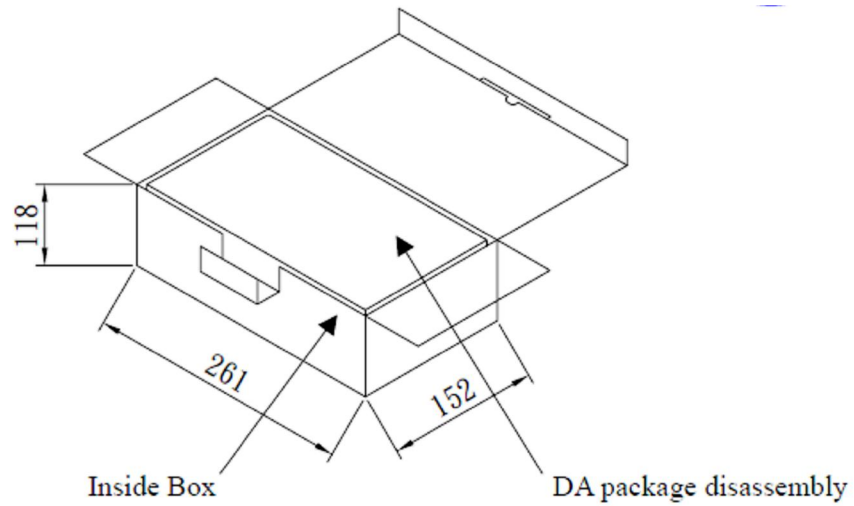

Taoglas makes no warranties based on the accuracy or completeness of the contents of this document and reserves the right to make changes to specifications and product descriptions at any time without notice. Taoglas reserves all rights to this document and the information contained herein. Reproduction, use or disclosure to third parties without express permission is strictly prohibited. Copyright © 2012, Taoglas Ltd.

Appendix C: 915 MHz ISM Antenna

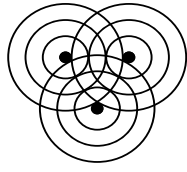

Murandi
Communications Ltd.
Innovative Radio Frequency Solutions

MLink Antenna Specification

Revision – Draft

Feb 10, 2014

Murandi Communications Ltd.

106, 4715 - 13th St. NE, Calgary, Alberta, Canada, T2E 6M3

Tel: (403) 777-9988

email murandi@murandi.com

Fax: (403) 777-9989

www.murandi.com

Confidential and Proprietary

Table of Contents

1 REVISION HISTORY 2

2 ABBREVIATIONS..... 2

3 REFERENCE DOCUMENTS..... 3

4 INTRODUCTION..... 3

5 ANTENNA SPECIFICATION..... 3

6 REVISIONS..... 4

1 Revision History

Revision	Date	Description
Draft	Feb 10, 2014	Initial release

The details of each revision are captured in Revision Details Section 6.

2 Abbreviations

Abbreviation	Description
Attn	attenuator
BW	bandwidth
dB	decibel
dBc	decibel relative to carrier power
dBi	decibel relative to an isotropic antenna
dBm	decibel relative to 1 milliwatt
FCC	federal communications commission
FHSS	frequency hopping spread spectrum
GPS	global positioning system
IC	Industry Canada
ISM	industrial, scientific and medical
ISR	interrupt service routine
kHz	kilohertz
LCD	liquid crystal display
LED	light emitting diode
LNA	low noise amplifier
mA	milliampere
mcd	millicandle
MHz	mega-hertz
mm	millimeter
msec	millisecond
mV	millivolt
PA	power amplifier
PLL	phase locked loop
ppm	parts per million
RBW	resolution bandwidth
RF	radio frequency
RTC	Real time clock

Abbreviation	Description
TBC	to be confirmed
TBD	to be determined
TRP	total radiated power
μ A	microampere
TDD	Time division duplex
UART	universal asynchronous receiver/transmitter
V	volts
W	width

3 Reference Documents

1. MLink Circuit Description – Draft, Feb 10, 2014
2. MLink Block Diagrams – Draft, Feb 10, 2014
3. Schematics (MLINK – Rev 3.pdf)
4. Bill of Materials (MLINK – Rev 3.bom)
5. Pictures (IMG_1673.jpg, IMG_1677.jpg, IMG_1680.jpg, IMG_1682.jpg, IMG_1684.jpg, & IMG_1695.jpg)

4 Introduction

This document contains Antenna Specifications for the Murandi Communications MLink 900 MHz transceiver as part of the FCC & IC submission.

5 Antenna Specification

MLink 900 integral antenna performance was measured in the following orientation:

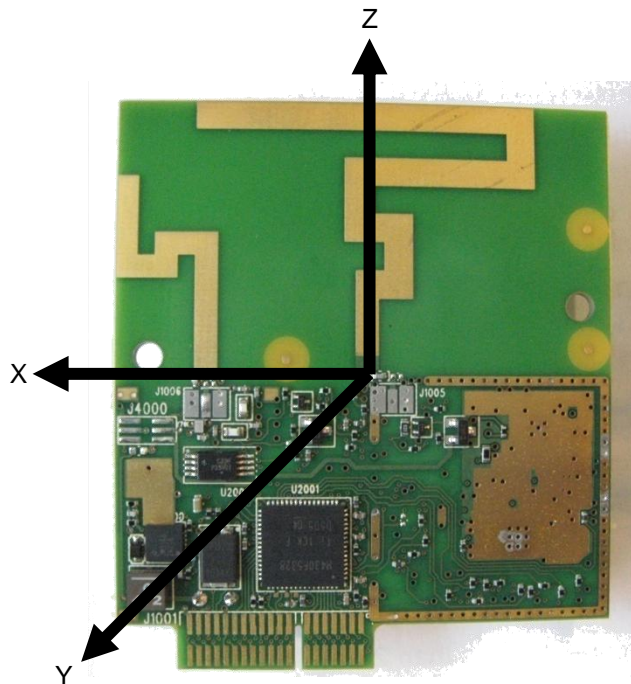

The following results obtained:



Total Radiated power: -0.41 dBm
Efficiency -0.11 dB

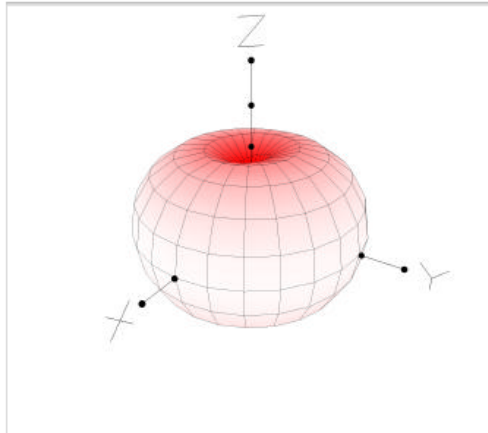

Vertical Polarization

Vert. Component: -0.43 dBm

Peak Gain: 2.14 dBi

Theta 90, Phi 285

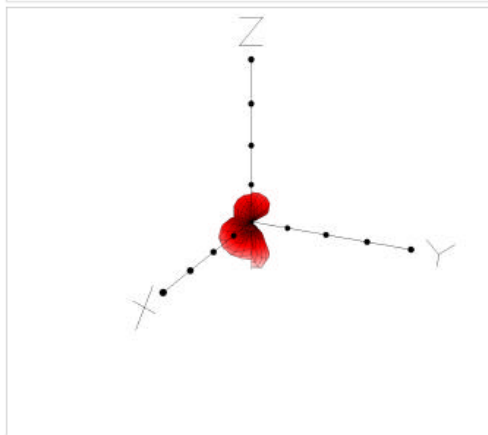

Horizontal Polarization

Horz. Component: -23.26 dBm

Peak Gain: -14.22 dBi

Theta 165, Phi 75

File Name: MLink 65558 33pF 915MHz with 2AA cells extender

Tx Power: -0.30 dBm Estimated

Frequency: 915.50 MHz

Cable Attenuation: 1.45 dB

Notes:

Fri, Nov 15, 2013 12:29 PM

Receive Antenna Gain: 1.65 dBi

Separation: 1.20 m

The peak antenna gain is 2.4 dBi in the vertical polarization.

6 Revisions

Murandi Communications Ltd.

106, 4715 - 13th St. NE, Calgary, Alberta, Canada, T2E 6M3

Tel: (403) 777-9988

email murandi@murandi.com

Fax: (403) 777-9989

www.murandi.com

Confidential and Proprietary