

TEST REPORT  
For

SHANGHAI UTT TECHNOLOGIES CO., LTD.

Router

Model No.: U2000, U2512, U1200, U2200, U3200

FCC ID: XPF-REG01-UTT

Prepared for : SHANGHAI UTT TECHNOLOGIES CO., LTD.  
Address : Room 301, No.9 Building, No.518, Xinzhuan Rd., Songjiang  
District, Shanghai, China

Prepared by : SHENZHEN EMTEK CO., LTD.  
Address : Bldg 69, Majialong Industry Zone,  
Nanshan District, Shenzhen, Guangdong, China

Tel: (0755) 26954280  
Fax: (0755) 26954282

Report Number : ES111230179F  
Date of Test : December 31, 2011 to March 9, 2012  
Date of Report : March 10, 2012

## TABLE OF CONTENT

Test Report Description	Page
<b>1. SUMMARY OF TEST RESULT .....</b>	<b>4</b>
<b>2. GENERAL INFORMATION.....</b>	<b>5</b>
2.1. Description of Device (EUT).....	5
2.2. Description of Support Device.....	6
2.3. Description of Test Facility.....	7
2.4. Measurement Uncertainty.....	7
<b>3. MEASURING DEVICE AND TEST EQUIPMENT .....</b>	<b>8</b>
3.1. For Power Line Conducted Emission Measurement.....	8
3.2. For Radiated Emission Measurement(3m Chamber).....	8
<b>4. POWER LINE CONDUCTED EMISSION MEASUREMENT.....</b>	<b>9</b>
4.1. Block Diagram of Test Setup.....	9
4.2. Measuring Standard.....	9
4.3. Power Line Conducted Emission Limits (Class B).....	9
4.4. EUT Configuration on Measurement.....	9
4.5. Operating Condition of EUT.....	10
4.6. Test Procedure.....	10
4.7. Measuring Results.....	10
<b>5. RADIATED EMISSION MEASUREMENT.....</b>	<b>11</b>
5.1. Block Diagram of Test Setup.....	11
5.2. Measuring Standard.....	11
5.3. Radiated Emission Limits (Class B).....	12
5.4. EUT Configuration on Measurement.....	12
5.5. Operating Condition of EUT.....	12
5.6. Test Procedure.....	12
5.7. Measuring Results.....	13
<b>6. PHOTOGRAPHS.....</b>	<b>14</b>
6.1. Photos of Conducted Emission Measurement.....	14
6.2. Photos of Radiation Emission Measurement.....	15
APPENDIX I (2 Pages)	
APPENDIX II (4 Pages)	
APPENDIX III (Photos of EUT) (6 Pages)	

### TEST REPORT DESCRIPTION

Applicant : SHANGHAI UTT TECHNOLOGIES CO., LTD.  
 Manufacturer : SHANGHAI UTT TECHNOLOGIES CO., LTD.  
 Trademark :  艾泰  
 EUT : Router  
 Model No. : U2000, U2512, U1200, U2200, U3200  
 FCC ID : XPF-REG01-UTT  
 Power Supply : AC 100-240V 50-60Hz, 0.6A

Measurement Procedure Used:

FCC Rules and Regulations Part 15 Subpart B Class B & FCC / ANSI C63.4-2009

The device described above is tested by SHENZHEN EMTEK CO., LTD. to determine the maximum emission levels emanating from the device and the severe levels of the device can endure and its performance criterion. The measurement results are contained in this test report and SHENZHEN EMTEK CO., LTD. is assumed full of responsibility for the accuracy and completeness of these measurements. Also, this report shows that the EUT (Equipment Under Test) is technically compliant with the FCC requirements.

This report applies to above tested sample only and shall not be reproduced in part without written approval of SHENZHEN EMTEK CO., LTD.

Date of Test : December 31, 2011 to March 9, 2012

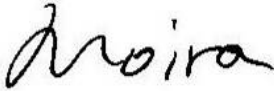
Prepared by :   
 (Engineer)

Reviewer :   
 (Quality Manager)

Approved & Authorized Signer :   
 (Manager)

# 1. SUMMARY OF TEST RESULT

<b>EMISSION</b>		
Description of Test Item	Standard & Limits	Results
Conducted Disturbance at Mains Terminals	FCC Part 15, Subpart B, Class B ANSI C63.4: 2009	Pass
Radiated Disturbance	FCC Part 15, Subpart B, Class B ANSI C63.4: 2009	Pass
Note: N/A is an abbreviation for Not Applicable.		

## 2. GENERAL INFORMATION

### 2.1. Description of Device (EUT)

EUT	:	Router
Model Number	:	U2000, U2512, U1200, U2200, U3200 (Note: all the models are the same, except their model number. We take U2000 to test.)
Test Voltage	:	AC 120V/60Hz
Applicant	:	SHANGHAI UTT TECHNOLOGIES CO., LTD.
Address	:	Room 301, No.9 Building, No.518, Xinzhuan Rd., Songjiang District, Shanghai, China
Manufacturer	:	SHANGHAI UTT TECHNOLOGIES CO., LTD.
Address	:	Room 301, No.9 Building, No.518, Xinzhuan Rd., Songjiang District, Shanghai, China
Date of Received	:	December 31, 2011
Date of Test	:	December 31, 2011 to March 9, 2012

## 2.2. Description of Support Device

PC : Manufacturer: LENOVO  
M/N: 9702  
S/N: L3C4410  
CE, FCC: DOC  
Power cord : Unshielded, Detachabled, 1.5m

LCD Monitor : Manufacturer: LENOVO  
M/N: 9227-AE6  
S/N:4M0293084302824  
CE, FCC: DOC  
Power cord : Unshielded, Detachabled, 1.5m  
Data Cable: Unshielded, Detachabled, 2.0m

LED Monitor : Manufacturer: PHILIPS  
M/N: 224EL2  
S/N:DLAA1111431625  
CE, FCC: DOC  
Power cord : Unshielded, Detachabled, 1.5m  
Data Cable: Unshielded, Detachabled, 2.0m

Keyboard : Manufacturer: LENOVO  
M/N: KU-0225  
S/N:0585494  
CE, FCC: DOC  
Data Cable: Unshielded, Undetachabled, 2.0m

Mouse : Manufacturer: LENOVO  
M/N: MO28UOL  
S/N:44G7862 068  
CE, FCC: DOC  
Data Cable: Unshielded, Undetachabled, 2.0m

Printer : Manufacturer: HP  
M/N: C89520  
S/N: CN25S182N6  
CE, FCC: DOC  
USB Cable : Unshielded, Detachabled, 1.8m  
Power cord :Unshielded, Detachabled, 1.8m

## 2.3. Description of Test Facility

### Site Description

EMC Lab. : Accredited by CNAS, 2010.10.29  
The certificate is valid until 2013.10.28  
The Laboratory has been assessed and proved to be in compliance with CNAS-CL01:2006 (identical to ISO/IEC 17025:2005)  
The Certificate Registration Number is L2291.

Accredited by TUV Rheinland Shenzhen 2010.5.25  
The Laboratory has been assessed according to the requirements ISO/IEC 17025.

Accredited by FCC, October 28, 2010  
The Certificate Registration Number is 406365.

Accredited by Industry Canada, March 5, 2010  
The Certificate Registration Number is 46405-4480.

Name of Firm : SHENZHEN EMTEK CO., LTD.  
Site Location : Bldg 69, Majialong Industry Zone,  
Nanshan District, Shenzhen, Guangdong, China

## 2.4. Measurement Uncertainty

Conducted Emission Uncertainty : 2.8dB

Radiated Emission Uncertainty : 3.3dB (3m Chamber)

### 3. MEASURING DEVICE AND TEST EQUIPMENT

#### 3.1. For Power Line Conducted Emission Measurement

Item	Equipment	Manufacturer	Model No.	Serial No.	Last Cal.	Cal. Interval
1.	Test Receiver	Rohde & Schwarz	ESCS30	100162	May 29, 2011	1 Year
2.	L.I.S.N.	Rohde & Schwarz	ENV216	3560.6550.12	May 29, 2011	1 Year
3.	50Ω Coaxial Switch	Anritsu	MP59B	6100214550	N/A	N/A
4.	Voltage Probe	Rohde & Schwarz	TK9416	N/A	May 29, 2011	1 Year
5.	I.S.N	Rohde & Schwarz	ENY22	1109.9508.02	May 29, 2011	1 Year

#### 3.2. For Radiated Emission Measurement(3m Chamber)

Item	Equipment	Manufacturer	Model No.	Serial No.	Last Cal.	Cal. Interval
1.	EMI Test Receiver	Rohde & Schwarz	ESU	1302.6005.26	May 29, 2011	1 Year
2.	Pre-Amplifier	HP	8447D	2944A07999	May 29, 2011	1 Year
3.	Bilog Antenna	Schwarzbeck	VULB9163	142	May 29, 2011	1 Year
4.	Loop Antenna	ARA	PLA-1030/B	1029	May 29, 2011	1 Year
5.	Horn Antenna	Schwarzbeck	BBHA 9170	BBHA91703 99	May 29, 2011	1 Year
6.	Horn Antenna	Schwarzbeck	BBHA 9120	D143	May 29, 2011	1 Year
7.	Cable	Schwarzbeck	AK9513	ACRX1	May 29, 2011	1 Year
8.	Cable	Rosenberger	N/A	FP2RX2	May 29, 2011	1 Year
9.	Cable	Schwarzbeck	AK9513	CRPX1	May 29, 2011	1 Year
10.	Cable	Schwarzbeck	AK9513	CRRX2	May 29, 2011	1 Year



## 4. POWER LINE CONDUCTED EMISSION MEASUREMENT

### 4.1. Block Diagram of Test Setup

During test, continuous communication was taking place between the EUT and the host computer by a batch file loop that constantly uploads- and deletes a video file of 50MByte from the PC into the EUT without interruption.

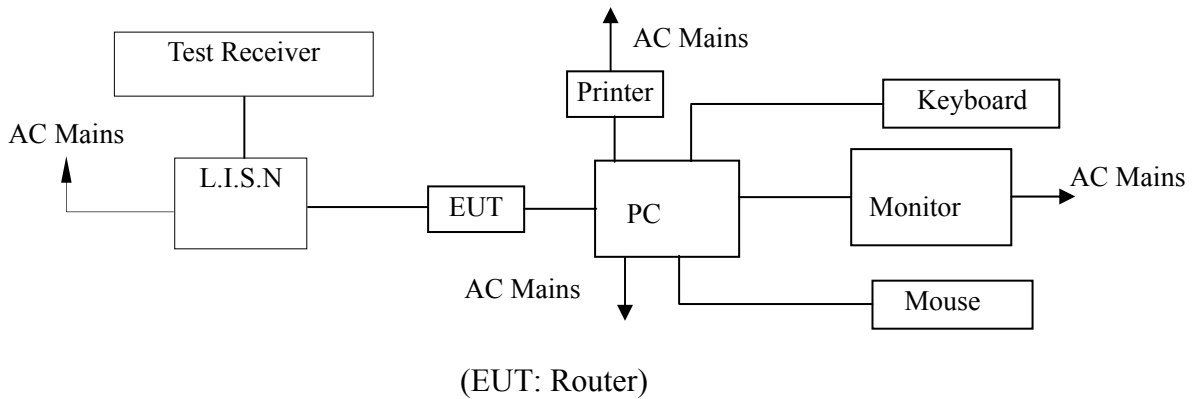

### 4.2. Measuring Standard

FCC Part 15, Subpart B, Class B ANSI C63.4: 2009

### 4.3. Power Line Conducted Emission Limits (Class B)

Frequency (MHz)	Limit (dB $\mu$ V)	
	Quasi-peak Level	Average Level
0.15 ~ 0.50	66.0 ~ 56.0 *	56.0 ~ 46.0 *
0.50 ~ 5.00	56.0	46.0
5.00 ~ 30.00	60.0	50.0

NOTE1-The lower limit shall apply at the transition frequencies.  
NOTE2-The limit decreases linearly with the logarithm of the frequency in the range 0.15MHz to 0.50MHz.

### 4.4. EUT Configuration on Measurement

The following equipments are installed on Conducted Emission Measurement to meet FCC requirements and operating in a manner which tends to maximize its emission characteristics in a normal application.

EUT : Router  
Model Number : U2000

#### 4.5. Operating Condition of EUT

4.5.1. Setup the EUT as shown on Section 4.1.

4.5.2. Turn on the power of all equipments.

4.5.3. Let the EUT work in measuring mode (Connect to PC(Ping)) and measure it.

#### 4.6. Test Procedure

The EUT is put on the plane 0.8m high above the ground by insulating support and connect to the AC mains through Line Impedance Stability Network (L.I.S.N). This provided a 50ohm coupling impedance for the tested equipments. Both sides of AC line are investigated to find out the maximum conducted emission according to the FCC regulations during conducted emission measurement.

The bandwidth of the field strength meter (R&S Test Receiver ESCS30) is set at 9kHz in 150kHz~30MHz and 200Hz in 9kHz~150kHz.

The frequency range from 150kHz to 30MHz is investigated.

All the scanning waveform is put in Appendix I.

#### 4.7. Measuring Results

**PASS.**

Please refer to Appendix I.

## 5. RADIATED EMISSION MEASUREMENT

### 5.1. Block Diagram of Test Setup

#### 5.1.1. Block diagram of connection between the EUT and simulators

During test, continuous communication was taking place between the EUT and the host computer by a batch file loop that constantly uploads- and deletes a video file of 50MByte from the PC into the EUT without interruption.

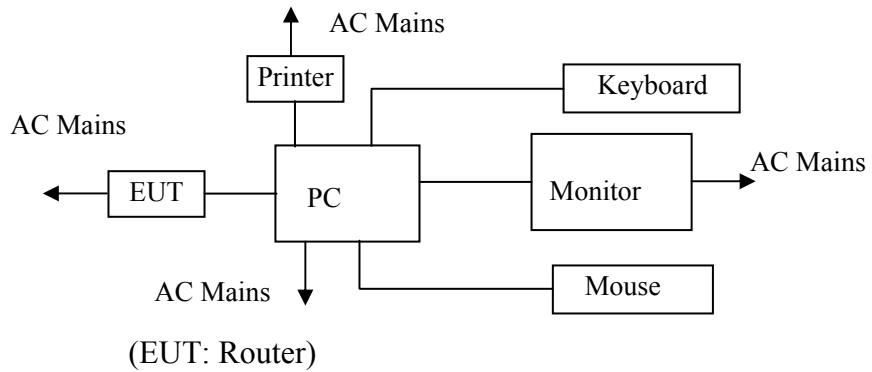

#### 5.1.2. Block diagram of test setup (In chamber)

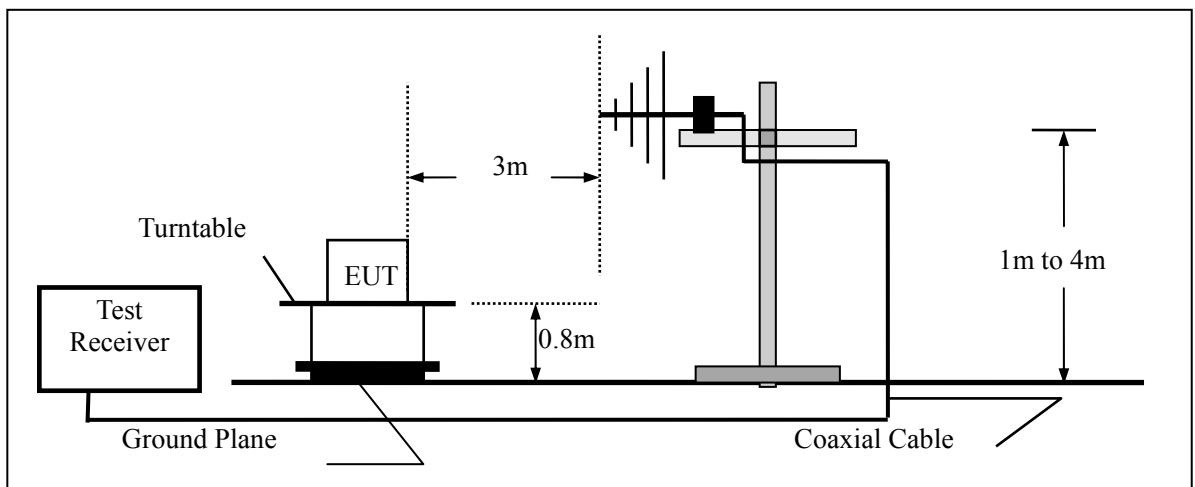

(EUT: Router)

### 5.2. Measuring Standard

FCC Part 15, Subpart B, Class B ANSI C63.4: 2009

### 5.3.Radiated Emission Limits (Class B)

Frequency MHz	Distance Meters	Field Strengths Limit	
		μV/m	dB(μV)/m
30 ~ 88	3	100	40.0
88 ~ 216	3	150	43.5
216 ~ 960	3	200	46.0
960 ~ 1000	3	500	54.0

Frequency (GHz)	Distance (Meters)	Field Strengths Limit	
		Average (dBμV/m)	Peak (dBμV/m)
1~6	3	54	74

- Remark:
- (1) Emission level (dB)μV = 20 log Emission level μV/m
  - (2) The smaller limit shall apply at the cross point between two frequency bands.
  - (3) Distance is the distance in meters between the measuring instrument, antenna and the closest point of any part of the device or system.

### 5.4.EUT Configuration on Measurement

The FCC Class B regulations test method must be used to find the maximum emission during radiated emission measurement.

EUT : Router  
 Model Number : U2000

### 5.5.Operating Condition of EUT

5.5.1.Setup the EUT as shown on Section 5.1.

5.5.2.Turn on the power of all equipments.

5.5.3.Let the EUT work in measuring mode (Connect to PC(Ping) ) and measure it.

### 5.6.Test Procedure

The EUT is placed on a turn table which is 0.8 meter high above the ground. The turn table can rotate 360 degrees to determine the position of the maximum emission level. The EUT is set 3 meters away from the receiving antenna which is mounted on a antenna tower. The antenna can be moved up and down from 1 to 4 meters to find out the maximum emission level. Bilog antenna (calibrated by Dipole Antenna) and horn antenna are used as a receiving antenna. Both horizontal and vertical polarization of the antenna are set on test.

The bandwidth of the Receiver is set at 120kHz.  
 The scanning curves are attached in Appendix II.

## 5.7.Measuring Results

**PASS.**

The frequency range from 30MHz to 6GHz is investigated.  
Please refer to Appendix II.

## 6. PHOTOGRAPHS

### 6.1.Photos of Conducted Emission Measurement



6.2.Photos of Radiation Emission Measurement

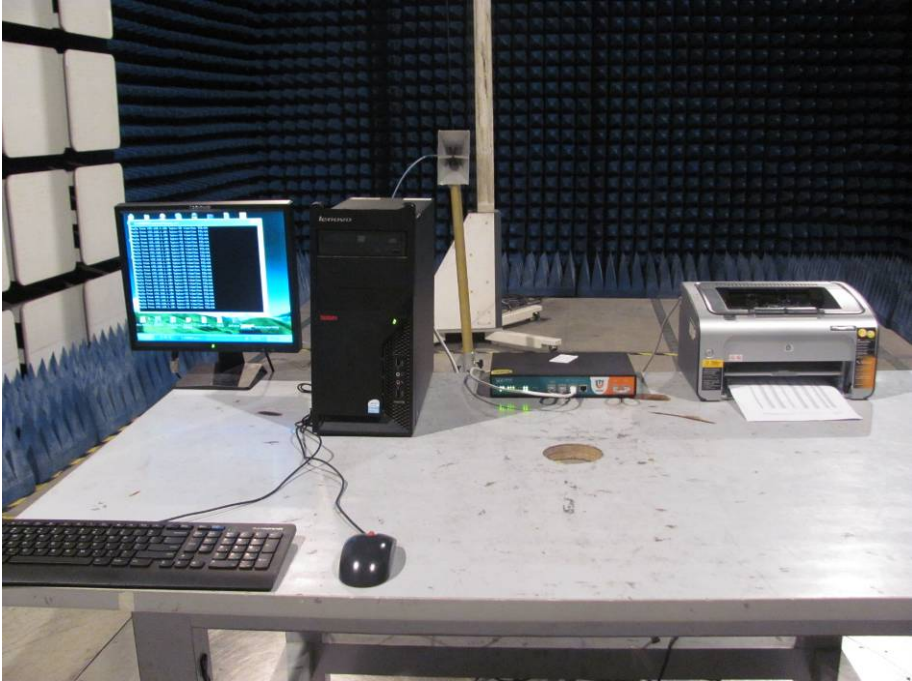
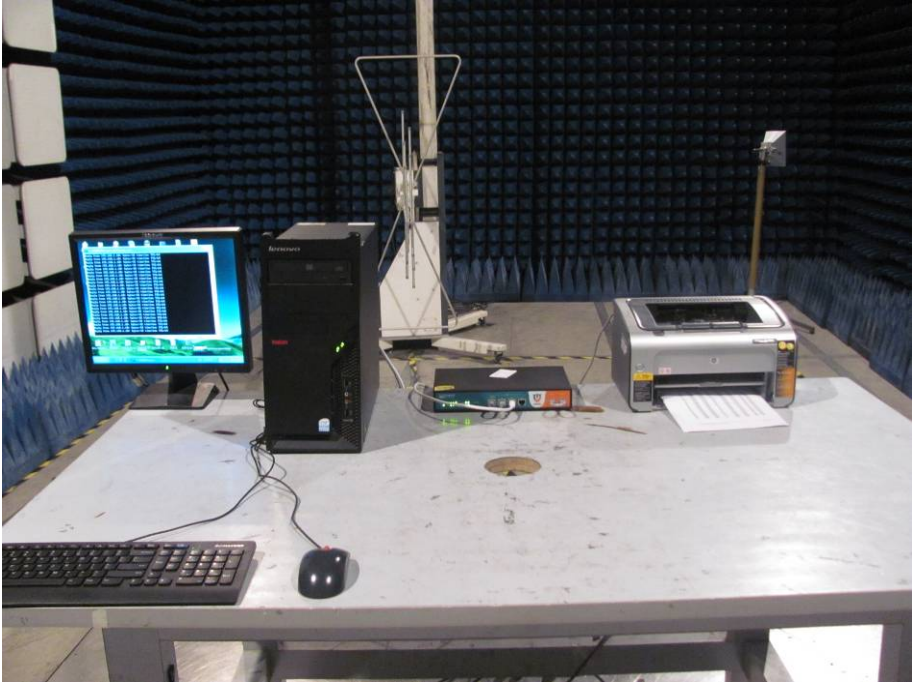





# APPENDIX I

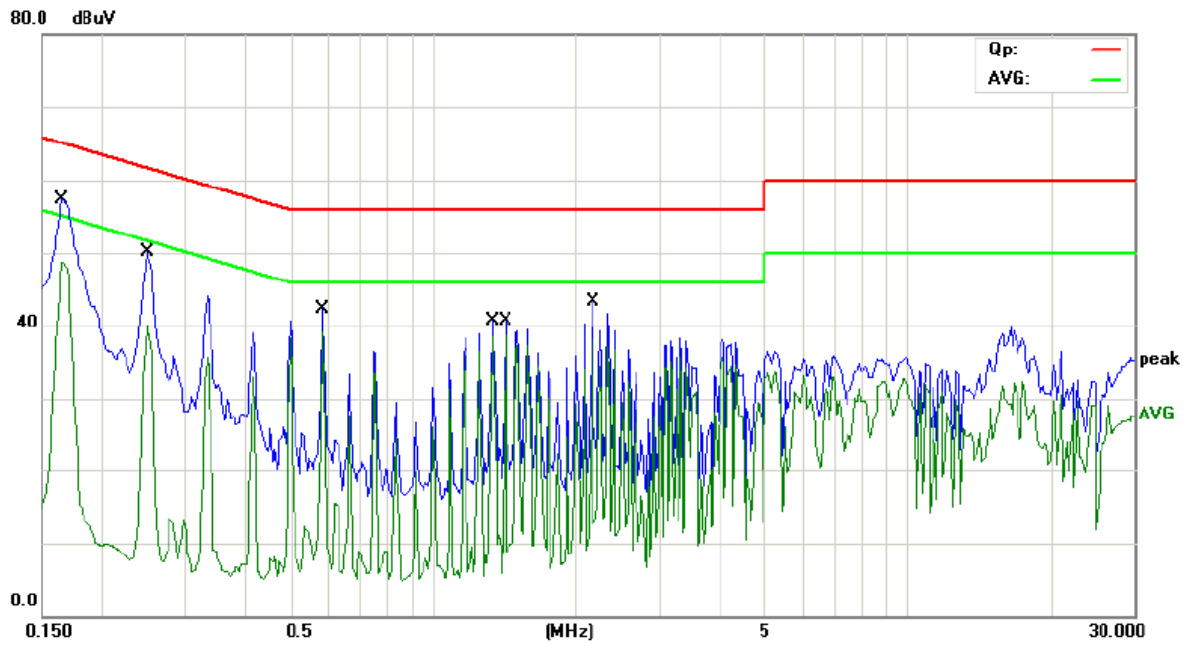

Site Conduction #1

Phase: **N**

Temperature: 26

Limit: (CE)FCC PART 15 class B\_QP

Power: AC 120V/60Hz

Humidity: 60 %

Mode: connect to pc (ping)

Note:

No.	Mk.	Freq. MHz	Reading Level dBuV	Correct Factor dB	Measure- ment dBuV	Limit dBuV	Over dB	Detector	Comment
1		0.1650	57.20	0.00	57.20	65.21	-8.01	QP	
2	*	0.1650	48.79	0.00	48.79	55.21	-6.42	AVG	
3		0.2500	50.10	0.00	50.10	61.76	-11.66	QP	
4		0.2500	40.09	0.00	40.09	51.76	-11.67	AVG	
5		0.5850	42.21	0.00	42.21	56.00	-13.79	QP	
6		0.5850	39.13	0.00	39.13	46.00	-6.87	AVG	
7		1.3350	40.63	0.00	40.63	56.00	-15.37	QP	
8		1.3350	38.42	0.00	38.42	46.00	-7.58	AVG	
9		1.4200	40.71	0.00	40.71	56.00	-15.29	QP	
10		1.4200	38.61	0.00	38.61	46.00	-7.39	AVG	
11		2.1700	43.28	0.00	43.28	56.00	-12.72	QP	
12		2.1700	38.19	0.00	38.19	46.00	-7.81	AVG	

\*:Maximum data    x:Over limit    !:over margin    Comment: Factor build in receiver.    Operator: Ricky

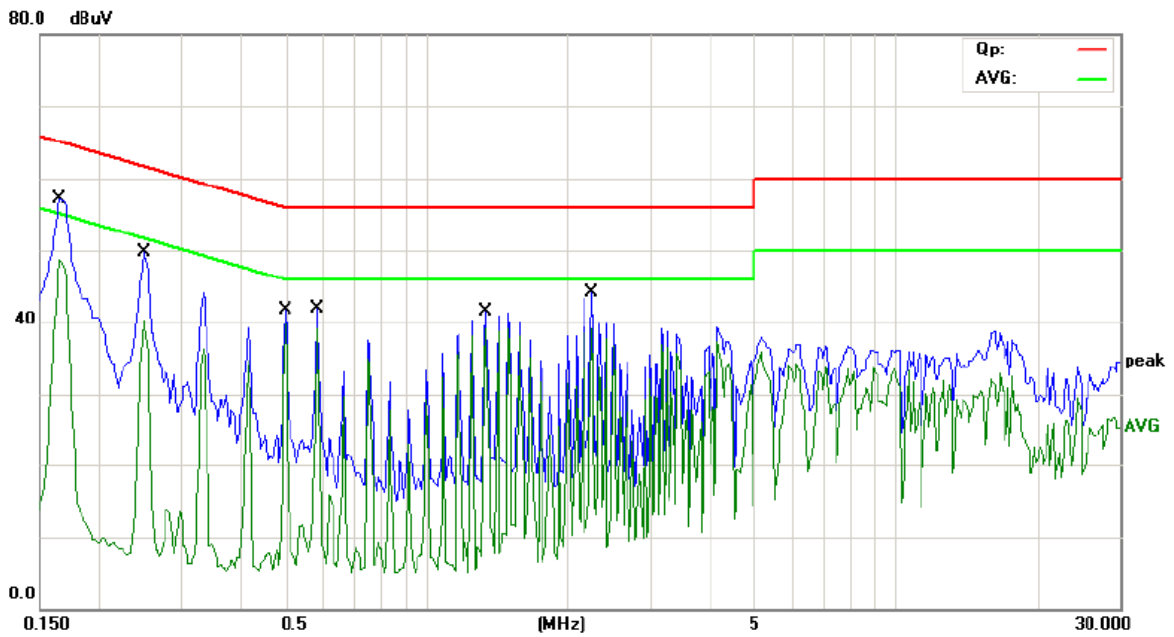

Site Conduction #1 Phase: **L1** Temperature: 26  
 Limit: (CE)FCC PART 15 class B\_QP Power: AC 120V/60Hz Humidity: 60 %  
 Mode: connect to pc (ping)  
 Note:

No.	Mk.	Freq.	Reading Level	Correct Factor	Measurement	Limit	Over	Detector	Comment
		MHz	dBuV	dB	dBuV	dBuV	dB		
1		0.1650	56.91	0.00	56.91	65.21	-8.30	QP	
2		0.1650	48.67	0.00	48.67	55.21	-6.54	AVG	
3		0.2500	49.74	0.00	49.74	61.76	-12.02	QP	
4		0.2500	40.30	0.00	40.30	51.76	-11.46	AVG	
5		0.5000	41.79	0.00	41.79	56.00	-14.21	QP	
6	*	0.5000	39.63	0.00	39.63	46.00	-6.37	AVG	
7		0.5850	41.99	0.00	41.99	56.00	-14.01	QP	
8		0.5850	39.13	0.00	39.13	46.00	-6.87	AVG	
9		1.3350	41.48	0.00	41.48	56.00	-14.52	QP	
10		1.3350	39.04	0.00	39.04	46.00	-6.96	AVG	
11		2.2500	44.12	0.00	44.12	56.00	-11.88	QP	
12		2.2500	39.16	0.00	39.16	46.00	-6.84	AVG	

\*:Maximum data x:Over limit !:over margin Comment: Factor build in receiver. Operator: Ricky

## APPENDIX II

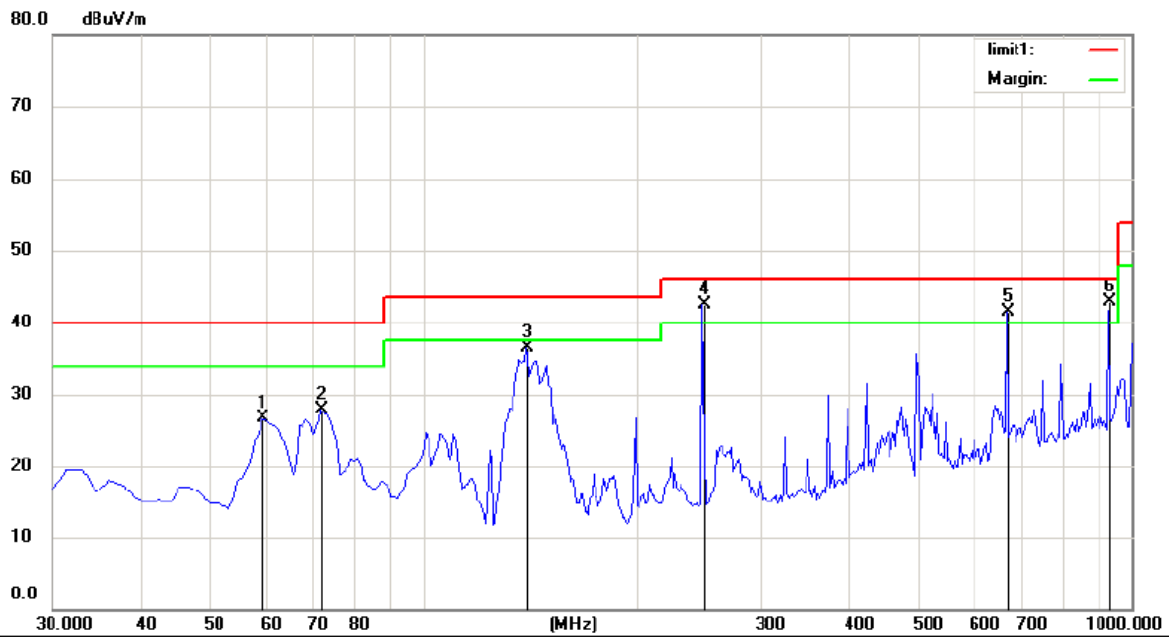

Site site #1 Polarization: **Horizontal** Temperature: 26  
 Limit: (RE)FCC PART 15 CLASS B Power: AC 120V/60Hz Humidity: 60 %  
 Mode:CONNECT TO PC(PING)  
 Note:

No.	Mk.	Freq. MHz	Reading Level dBuV	Correct Factor dB	Measure- ment dBuV/m	Limit dBuV/m	Over dB	Antenna Height cm	Table Degree degree	Comment
1		59.5352	13.42	13.19	26.61	40.00	-13.39			QP
2		71.9711	17.32	10.52	27.84	40.00	-12.16			QP
3		140.3684	27.68	8.83	36.51	43.50	-6.99			QP
4	!	249.1827	28.97	13.59	42.56	46.00	-3.44			QP
5	!	667.3396	19.75	21.77	41.52	46.00	-4.48			QP
6	*	934.7115	18.40	24.53	42.93	46.00	-3.07			QP

\*:Maximum data x:Over limit !:over margin

Operator: WOLF

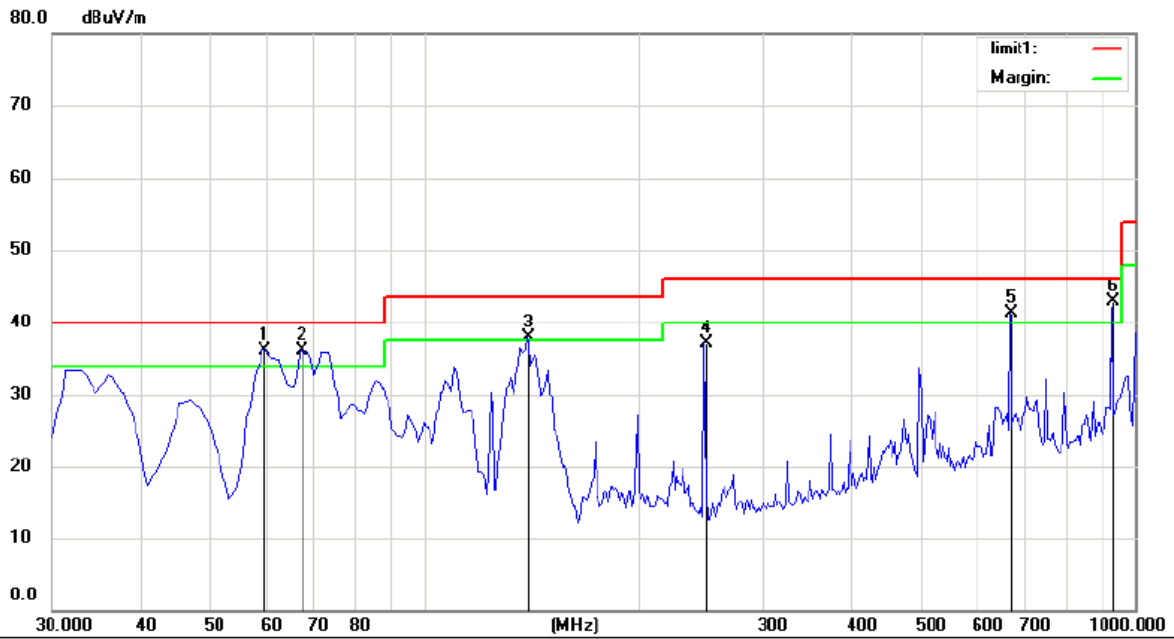

Site site #1 Polarization: **Vertical** Temperature: 26  
 Limit: ( RE)FCC PART 15 CLASS B Power: AC 120V/60Hz Humidity: 60 %  
 Mode:CONNECT TO PC(PING)  
 Note:

No.	Mk.	Freq.	Reading Level	Correct Factor	Measurement	Limit	Over	Antenna Height	Table Degree	
		MHz	dBuV	dB	dBuV/m	dBuV/m	dB	cm	degree	Comment
1	!	59.8830	22.98	13.17	36.15	40.00	-3.85			QP
2	!	67.3076	25.87	10.28	36.15	40.00	-3.85			QP
3	!	140.3684	29.16	8.84	38.00	43.50	-5.50			QP
4		249.1827	24.33	12.86	37.19	46.00	-8.81			QP
5	!	667.3396	18.50	22.86	41.36	46.00	-4.64			QP
6	*	934.7115	18.40	24.57	42.97	46.00	-3.03			QP

\*:Maximum data x:Over limit !:over margin

Operator: WOLF

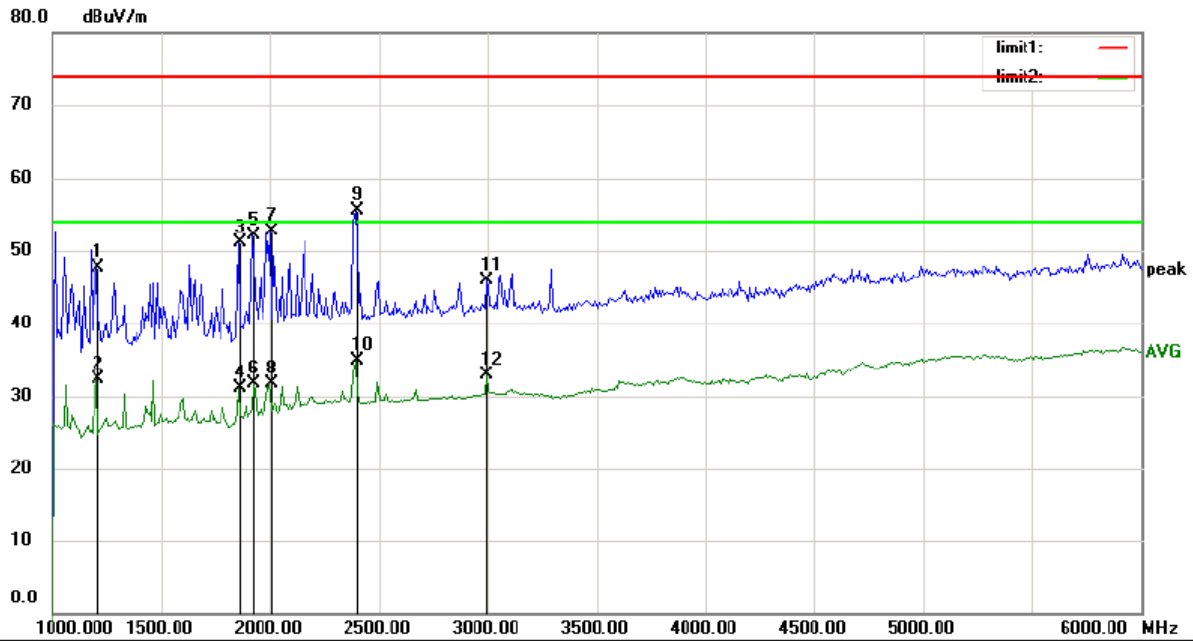

Site site #1 Polarization: **Horizontal** Temperature: 26  
 Limit: ( RE)FCC PART 15 CLASS B Power: AC 120V/60Hz Humidity: 60 %  
 Mode:CONNECT TO PC(PING)  
 Note:

No.	Mk.	Freq.	Reading Level	Correct Factor	Measurement	Limit	Over	Antenna Height	Table Degree	Detector	Comment
		MHz	dBuV	dB	dBuV/m	dBuV/m	dB	cm	degree		
1		1200.321	60.65	-13.02	47.63	74.00	-26.37			peak	
2		1200.321	45.32	-13.02	32.30	54.00	-21.70			AVG	
3		1857.372	62.95	-11.76	51.19	74.00	-22.81			peak	
4		1857.372	42.80	-11.76	31.04	54.00	-22.96			AVG	
5		1913.462	63.48	-11.35	52.13	74.00	-21.87			peak	
6		1913.462	43.01	-11.35	31.66	54.00	-22.34			AVG	
7		2001.603	63.47	-10.75	52.72	74.00	-21.28			peak	
8		2001.603	42.40	-10.75	31.65	54.00	-22.35			AVG	
9	*	2394.231	64.21	-8.66	55.55	74.00	-18.45			peak	
10		2394.231	43.59	-8.66	34.93	54.00	-19.07			AVG	
11		2995.192	53.43	-7.59	45.84	74.00	-28.16			peak	
12		2995.192	40.51	-7.59	32.92	54.00	-21.08			AVG	

\*:Maximum data x:Over limit !:over margin

Operator: KING

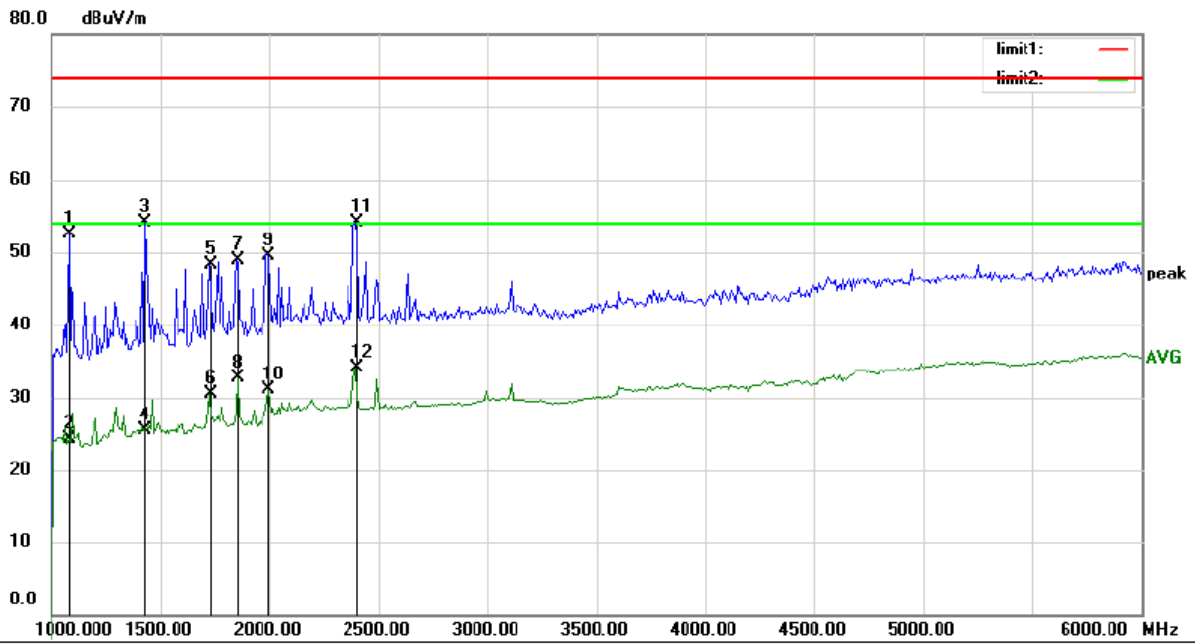

Site site #1 Polarization: **Vertical** Temperature: 26  
 Limit: (RE)FCC PART 15 CLASS B Power: AC 120V/60Hz Humidity: 60 %  
 Mode:CONNECT TO PC(PING)  
 Note:

No.	Mk.	Freq.	Reading	Correct	Measure-	Limit	Over	Antenna	Table	
		MHz	Level	Factor	ment			Height	Degree	Comment
			dBuV	dB	dBuV/m	dBuV/m	dB	cm	degree	
1		1080.128	65.90	-13.48	52.42	74.00	-21.58			peak
2		1080.128	37.86	-13.48	24.38	54.00	-29.62			AVG
3		1432.692	66.19	-12.17	54.02	74.00	-19.98			peak
4		1432.692	37.72	-12.17	25.55	54.00	-28.45			AVG
5		1721.154	60.59	-12.29	48.30	74.00	-25.70			peak
6		1721.154	42.80	-12.29	30.51	54.00	-23.49			AVG
7		1849.359	60.75	-11.82	48.93	74.00	-25.07			peak
8		1849.359	44.50	-11.82	32.68	54.00	-21.32			AVG
9		1985.577	60.46	-10.86	49.60	74.00	-24.40			peak
10		1985.577	41.88	-10.86	31.02	54.00	-22.98			AVG
11	*	2394.231	62.86	-8.66	54.20	74.00	-19.80			peak
12		2394.231	42.67	-8.66	34.01	54.00	-19.99			AVG

\*:Maximum data x:Over limit l:over margin

Operator: KING



## APPENDIX III (Photos of EUT)

