



FCC 47 CFR PART 22 SUBPART H AND PART 24 SUBPART E

TEST REPORT

For

CDMA2000 EV-DO Mobile Phone

Trade Name: Saygus

Model: V1

Issued to

**Saygus Global, Inc.
10421 South Jordan Gateway Suite 500,
South Jordan, UT84095,U.S.A**

Issued by

**Compliance Certification Services Inc.
No. 11, Wu-Gong 6th Rd., Wugu Industrial Park,
Taipei Hsien 248, Taiwan (R.O.C.)
<http://www.ccsemc.com.tw>
service@ccsrf.com**



Note: This report shall not be reproduced except in full, without the written approval of Compliance Certification Services Inc. This document may be altered or revised by Compliance Certification Services Inc. personnel only, and shall be noted in the revision section of the document.



TABLE OF CONTENTS

1. TEST RESULT CERTIFICATION.....	3
2. EUT DESCRIPTION	4
3. TEST METHODOLOGY	5
3.1 EUT CONFIGURATION	5
3.2 EUT EXERCISE	5
3.3 GENERAL TEST PROCEDURES	5
3.4 DESCRIPTION OF TEST MODES	6
4. INSTRUMENT CALIBRATION.....	7
4.1 MEASURING INSTRUMENT CALIBRATION	7
4.2 MEASUREMENT EQUIPMENT USED	8
4.3 MEASUREMENT UNCERTAINTY	9
5. FACILITIES AND ACCREDITATIONS	10
5.1 FACILITIES	10
5.2 EQUIPMENT	10
5.3 TABLE OF ACCREDITATIONS AND LISTINGS	11
6. SETUP OF EQUIPMENT UNDER TEST	12
6.1 SETUP CONFIGURATION OF EUT	12
6.2 SUPPORT EQUIPMENT	12
7. FCC PART 22 & 24 REQUIREMENTS	13
7.1 TRANSMIT POWER.....	13
7.2 ERP & EIRP MEASUREMENT	15
7.3 OCCUPIED BANDWIDTH MEASUREMENT	25
7.4 OUT OF BAND EMISSION AT ANTENNA TERMINALS	32
7.5 FIELD STRENGTH OF SPURIOUS RADIATION MEASUREMENT	44
7.6 FREQUENCY STABILITY V.S. TEMPERATURE MEASUREMENT	70
7.7 FREQUENCY STABILITY V.S. VOLTAGE MEASUREMENT	73
7.8 POWERLINE CONDUCTED EMISSIONS	76
APPENDIX I PHOTOGRAPHS OF TEST SETUP.....	79



1. TEST RESULT CERTIFICATION

Applicant: Saygus Global, Inc.
 10421 South Jordan Gateway Suite 500,
 South Jordan, UT84095,U.S.A

Equipment Under Test: CDMA2000 EV-DO Mobile Phone

Trade Name: Saygus

Model: V1

Date of Test: September 15 ~ 30, 2009

APPLICABLE STANDARDS	
STANDARD	TEST RESULT
FCC 47 CFR Part 22 Subpart H & Part 24 Subpart E	No non-compliance noted

We hereby certify that:

The above equipment was tested by Compliance Certification Services Inc. The test data, data evaluation, test procedures, and equipment configurations shown in this report were made in accordance with the procedures given in TIA/EIA-603-C: 2004 and the energy emitted by the sample EUT tested as described in this report is in compliance with conducted and radiated emission limits of FCC Rule FCC PART 22 Subpart H and PART 24 Subpart E.

The test results of this report relate only to the tested sample identified in this report.

Approved by:

Reviewed by:

Rex Lai
 Section Manager
 Compliance Certification Services Inc.

Gina Lo
 Section Manager
 Compliance Certification Services Inc.



2. EUT DESCRIPTION

Product	CDMA2000 EV-DO Mobile Phone
Trade Name	Saygus
Model Number	V1
Model Discrepancy	N/A
Power Supply	1. Power form host PC. 2. Battery: Rating: 3.7V, 1500mAh 3. Power Adapter: Saygus / V1 I/P: AC 100-240V, 50-60Hz O/P: DC 5V,1000mA
Frequency Range	TX: 824.7 ~ 848.31 MHz / 1851.25 ~ 1908.75 MHz RX: 869.7 ~ 893.31 MHz / 1931.25 ~ 1988.75 MHz
Transmit Power (ERP & EIRP Power)	CDMA2000 1xRTT 850 MHz: Slide Mode: 23.76 dBm 1900 MHz: Slide Mode: 24.31 dBm CDMA2000 1xEVDO 850 MHz: Close Mode: 24.49 dBm 1900 MHz: Close Mode: 24.22 dBm
Cellular Phone Protocol	CDMA2000 1xRTT CDMA2000 1xEVDO
Type of Emission	CDMA2000 1xRTT: 824.7 ~ 848.31 MHz: 1M28F9W--- 1851.25 ~ 1908.75 MHz: 1M27F9W--- CDMA2000 1xEVDO 824.7 ~ 848.31 MHz: 1M28F9W--- 1851.25 ~ 1908.75 MHz: 1M28F9W---
Antenna Gain	850 MHz: -4.25dBi 1900 MHz: -9.18dBi
Antenna Type	PIFA Antenna

Remark:

1. The sample selected for test was engineering sample that approximated to production product and was provided by manufacturer.
2. This submittal(s) (test report) is intended for FCC ID: XP3V1 filing to comply with Part 22 and Part 24 of the FCC 47 CFR Rules.



3. TEST METHODOLOGY

Both conducted and radiated testing were performed according to the procedures document on chapter 13 of ANSI C63.4: 2003, TIA/EIA-603-C: 2004 and FCC CFR 47, 2.1046, 2.1047, 2.1049, 2.1051, 2.1053, 2.1055 and 2.1057.

3.1 EUT CONFIGURATION

The EUT configuration for testing is installed on RF field strength measurement to meet the Commissions requirement and operating in a manner that intends to maximize its emission characteristics in a continuous normal application.

3.2 EUT EXERCISE

The EUT was operated in the engineering mode to fix the TX frequency that was for the purpose of the measurements.

3.3 GENERAL TEST PROCEDURES

Conducted Emissions

The EUT is placed on the turntable, which is 0.8 m above ground plane. According to the requirements in Section 13.1.4.1 of ANSI C63.4. Conducted emissions from the EUT measured in the frequency range between 0.15 MHz and 30MHz using CISPR Quasi-peak and average detector modes.

Radiated Emissions

The EUT is placed on a turn table, which is 0.8 m above ground plane. The turntable shall rotate 360 degrees to determine the position of maximum emission level. EUT is set 3m away from the receiving antenna, which varied from 1m to 4m to find out the highest emission. And also, each emission was to be maximized by changing the polarization of receiving antenna both horizontal and vertical. In order to find out the maximum emissions, exploratory radiated emission measurements were made according to the requirements in Section 13.1.4.1 of ANSI C63.4.



3.4 DESCRIPTION OF TEST MODES

The EUT (model: V1) had been tested under operating condition.

After verification, all tests were carried out with the worst case test modes as shown below except radiated spurious emission below 1GHz and power line conducted emissions below 30MHz, which worst case was in normal link mode only.

EUT staying in continuous transmitting mode was programmed.

Pre-scan was performed on RF conducted port to determine the worst-case scenario:

Band	Channel	SO2	SO2	SO55	SO55	TDSO SO32	1xEvDO Rev.0	1xEvDO Rev.0
		RC1/1 (dBm)	RC3/3 (dBm)	RC1/1 (dBm)	RC3/3 (dBm)	RC3/3 (dBm)	(FTAP) (dBm)	(RTAP) (dBm)
Cellular	1013	23.61	23.60	23.66	23.80	23.69	23.81	23.70
	384	23.34	23.47	23.47	23.55	23.51	23.53	23.48
	777	23.61	23.76	23.56	23.90	23.82	23.77	23.59
PCS	25	22.01	22.07	22.11	22.27	22.24	22.23	22.05
	600	22.50	22.40	22.61	22.76	22.61	22.36	22.21
	1175	21.86	21.94	21.91	22.11	22.05	22.12	22.04

Based on the above results from the different modulations, CDMA2000 1xRTT RC3, SO32 (+F-SCH) and 1xEvdo, FTAP370 were determined to be the worst-case scenario for all tests.

The worst emission was found:

in lie-down (X axis) for CDMA 2000 1xRTT cellular slide mode and CDMA 2000 1xEVDO cellular closed mode, CDMA 2000 1xEVDO PCS closed mode and in lie-down (Y axis) for CDMA 2000 1xRTT PCS closed mode.



4. INSTRUMENT CALIBRATION

4.1 MEASURING INSTRUMENT CALIBRATION

The measuring equipment, which was utilized in performing the tests documented herein, has been calibrated in accordance with the manufacturer's recommendations for utilizing calibration equipment, which is traceable to recognized national standards.



4.2 MEASUREMENT EQUIPMENT USED

Equipment Used for Emissions Measurement

Remark: Each piece of equipment is scheduled for calibration once a year.

Conducted Emissions Test Site				
Name of Equipment	Manufacturer	Model	Serial Number	Calibration Due
Spectrum Analyzer	Agilent	E4446A	MY43360131	03/05/2010
Power Meter	Agilent	E4416A	GB41291611	06/28/2010
Power Sensor	Agilent	E9327A	US40441097	06/28/2010
Temp. / Humidity Chamber	Terchy	MHG-150LF	930619	09/15/2010
DC Power Source	Agilent	E3640A	MY40001774	01/09/2010

3M Semi Anechoic Chamber				
Name of Equipment	Manufacturer	Model	Serial Number	Calibration Due
Spectrum Analyzer	Agilent	E4446A	US42510252	10/26/2009
Test Receiver	Rohde & Schwarz	ESCI	100064	11/30/2009
Switch Controller	TRC	Switch Controller	SC94050010	05/02/2010
4 Port Switch	TRC	4 Port Switch	SC94050020	05/02/2010
Horn-Antenna	TRC	HA-0502	06	06/03/2010
Horn-Antenna	TRC	HA-0801	04	10/20/2009
Bilog- Antenna	Sunol Sciences	JB3	A030205	09/11/2010
Loop Antenna	EMCO	6502	8905/2356	05/28/2010
Turn Table	Max-Full	MFT-120S	T120S940302	N.C.R.
Antenna Tower	Max-Full	MFA-430	A440940302	N.C.R.
Controller	Max-Full	MF-CM886	CC-C-1F-13	N.C.R.
Site NSA	CCS	N/A	FCC MRA: TW1039 IC: IC 2324G-1/-2	10/17/2010 11/04/2010
Reject Filter	Micro-Tronics	HPM13194	003	04/23/2010
S.G.	HP	83630B	3844A01022	07/08/2010
Substituted Dipole	Schwazbeck	VHAP/UHAP	998 +999/ 981+982	06/08/2010
Substituted Horn	EMCO	3115	00022257	12/16/2009
Test S/W	LABVIEW (V 6.1)			

Powerline Conducted Emissions Test Site				
Name of Equipment	Manufacturer	Model	Serial Number	Calibration Due
EMI Test Receiver 9kHz-30MHz	Rohde & Schwarz	ESHS30	828144/003	11/18/2009
Two-Line V-Network 9kHz-30MHz	Schaffner	NNB41	03/10013	06/10/2010
LISN 10kHz-100MHz	EMCO	3825/2	9106-1809	05/03/2010
Test S/W	LABVIEW (V 6.1)			



4.3 MEASUREMENT UNCERTAINTY

PARAMETER	UNCERTAINTY
Powerline Conducted Emission	+/- 2.81
3M Semi Anechoic Chamber / 30MHz ~ 1GHz	+/-3.7046
3M Semi Anechoic Chamber / Above 1GHz	+/-3.0958

Remark: This uncertainty represents an expanded uncertainty expressed at approximately the 95% confidence level using a coverage factor of k=2.



5. FACILITIES AND ACCREDITATIONS

5.1 FACILITIES

All measurement facilities used to collect the measurement data are located at

No.199, Chunghsen Road, Hsintien City, Taipei Hsien, Taiwan, R.O.C.

Tel: 886-2-2217-0894 / Fax: 886-2-2217-1029

No.11, Wugong 6th Rd., Wugu Industrial Park, Taipei Hsien 248, Taiwan

Tel: 886-2-2299-9720 / Fax: 886-2-2298-4045

No.81-1, Lane 210, Bade 2nd Rd., Luchu Hsiang, Taoyuan Hsien 338, Taiwan

Tel: 886-3-324-0332 / Fax: 886-3-324-5235

The sites are constructed in conformance with the requirements of ANSI C63.7, ANSI C63.4 and CISPR Publication 22.

5.2 EQUIPMENT

Radiated emissions are measured with one or more of the following types of linearly polarized antennas: tuned dipole, biconical, log periodic, bi-log, and/or ridged waveguide, horn. Spectrum analyzers with pre-selectors and quasi-peak detectors are used to perform radiated measurements.



Conducted emissions are measured with Line Impedance Stabilization Networks and EMI Test Receivers.

Calibrated wideband preamplifiers, coaxial cables, and coaxial attenuators are also used for making measurements.

All receiving equipment conforms to CISPR Publication 16-1, "Radio Interference Measuring Apparatus and Measurement Methods."



5.3 TABLE OF ACCREDITATIONS AND LISTINGS

Country	Agency	Scope of Accreditation	Logo
USA	FCC	3M Semi Anechoic Chamber (FCC MRA: TW1039) to perform FCC Part 15 measurements	 FCC MRA: TW1039
Taiwan	TAF	LP0002, RTTE01, FCC Method-47 CFR Part 15 Subpart C, D, E, RSS-210, RSS-310 IDA TS SRD, AS/NZS 4268, AS/NZS 4771, TS 12.1 & 12.2, ETSI EN 300 440-1, ETSI EN 300 440-2, ETSI EN 300 328, ETSI EN 300 220-1, ETSI EN 300 220-2, ETSI EN 301 893, ETSI EN 301 489-1/3/7/17 FCC OET Bulletin 65 + Supplement C, EN 50360, EN 50361, EN 50371, RSS 102, EN 50383, EN 50385, EN 50392, IEC 62209, CNS 14958-1, CNS 14959 FCC Method -47 CFR Part 15 Subpart B IEC / EN 61000-3-2, IEC / EN 61000-3-3, IEC / EN 61000-4-2/3/4/5/6/8/11	 Testing Laboratory 1309
Canada	Industry Canada	3M Semi Anechoic Chamber (IC 2324G-1 / IC 2324G-2) to perform	 IC 2324G-1 IC 2324G-2

* No part of this report may be used to claim or imply product endorsement by A2LA or any agency of the US Government.



6. SETUP OF EQUIPMENT UNDER TEST

6.1 SETUP CONFIGURATION OF EUT

See test photographs attached in Appendix I for the actual connections between EUT and support equipment.

6.2 SUPPORT EQUIPMENT

No.	Device Type	Brand	Model	Series No.	FCC ID	Data Cable	Power Cord
1	LCD Monitor	SAMSUNG	959NF	AQ19H2RT706126P	FCC DoC	Shielded, 1.8m with 2 cores	AC I/P: Unshielded, 1.8m DC O/P: Unshielded, 1.8m with a core
2	Notebook PC	IBM	2672 (X31)	99KPZYN	WLAN: ANO20030400LEG Bluetooth: ANO20020100MTN	LAN Cable: Unshielded, 10m Line Cable: Unshielded, 10m	AC I/P: Unshielded, 1.8m DC O/P: Unshielded, 1.8m with a core
3.	USB Mouse	HP	MO19UCA	20440964	FCC DoC	Shielded, 1.8m	N/A
4.	SD Card	SANDISK	N/A	AA0312MX	N/A	N/A	N/A

Remark:

1. All the equipment/cables were placed in the worst-case configuration to maximize the emission during the test.
2. Grounding was established in accordance with the manufacturer's requirements and conditions for the intended use.



7. FCC PART 22 & 24 REQUIREMENTS

7.1 TRANSMIT POWER

LIMIT

According to FCC §2.1046.

Test Configuration

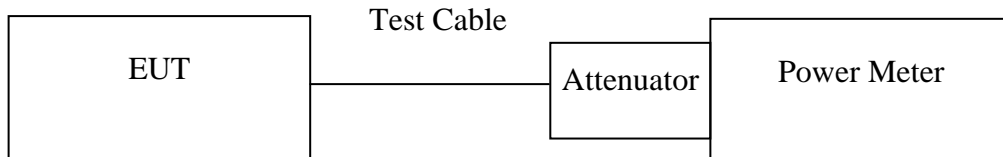

Remark: Measurement setup for testing on Antenna connector

TEST PROCEDURE

The transmitter output was connected to a calibrated attenuator, the other end of which was connected to a power meter. Transmitter output was read off the power meter in dBm. The power output at the transmitter antenna port was determined by adding the value of the attenuator to the power meter reading.

TEST RESULTS

No non-compliance noted.



Test Data

Average Power

Test Mode	CH	Frequency (MHz)	Average Power (dBm)
CDMA2000 1xRTT Cellular	1013	824.70	23.8
	384	836.52	23.55
	777	848.31	23.9
CDMA2000 1xEVDO Cellular	1013	824.70	23.81
	384	836.52	23.53
	777	848.31	23.77

Test Mode	CH	Frequency (MHz)	Average Power (dBm)
CDMA2000 1xRTT PCS	25	1851.25	22.27
	600	1880.00	22.76
	1175	1908.75	22.11
CDMA2000 1xEVDO PCS	25	1851.25	22.23
	600	1880.00	22.36
	1175	1908.75	22.12

Remark: The value of factor includes both the loss of cable and external attenuator

Peak Power

Test Mode	CH	Frequency (MHz)	Peak Power (dBm)
CDMA2000 1xRTT Cellular	1013	824.70	25.24
	384	836.52	25.43
	777	848.31	25.51
CDMA2000 1xEVDO Cellular	1013	824.70	25.73
	384	836.52	25.33
	777	848.31	25.58

Test Mode	CH	Frequency (MHz)	Peak Power (dBm)
CDMA2000 1xRTT PCS	25	1851.25	24.31
	600	1880.00	24.83
	1175	1908.75	24.24
CDMA2000 1xEVDO PCS	25	1851.25	24.31
	600	1880.00	24.46
	1175	1908.75	24.32

Remark: The value of factor includes both the loss of cable and external attenuator

7.2 ERP & EIRP MEASUREMENT

LIMIT

According to FCC §2.1046

FCC 22.913(b): The Effective Radiated Power (ERP) of mobile transmitters must not exceed 7 Watts.

FCC 24.232(b): The equivalent Isotropic Radiated Power (EIRP) must not exceed 2 Watts.

TEST CONFIGURATION

Below 1 GHz

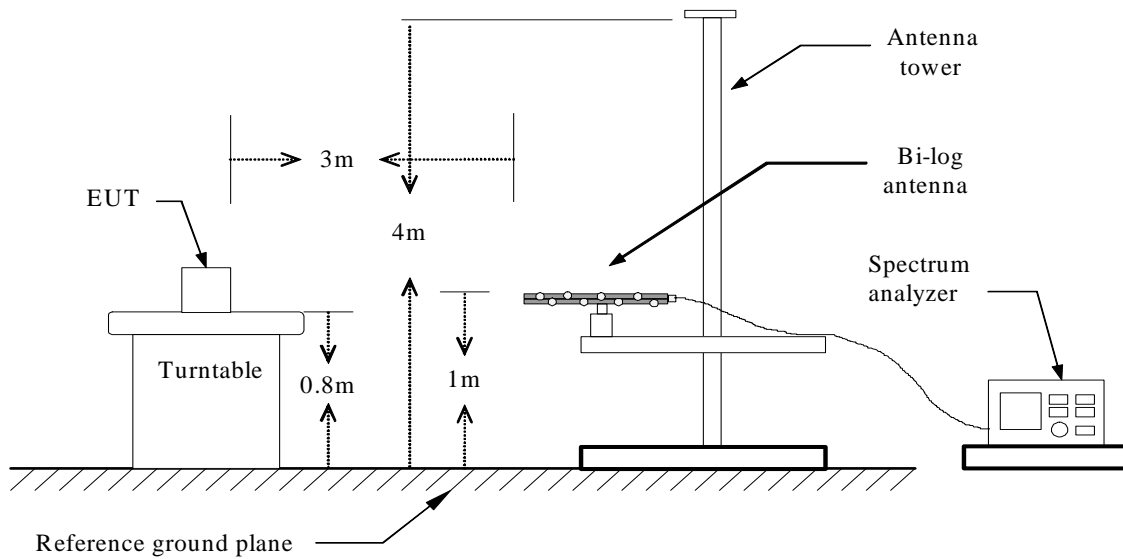

Above 1 GHz

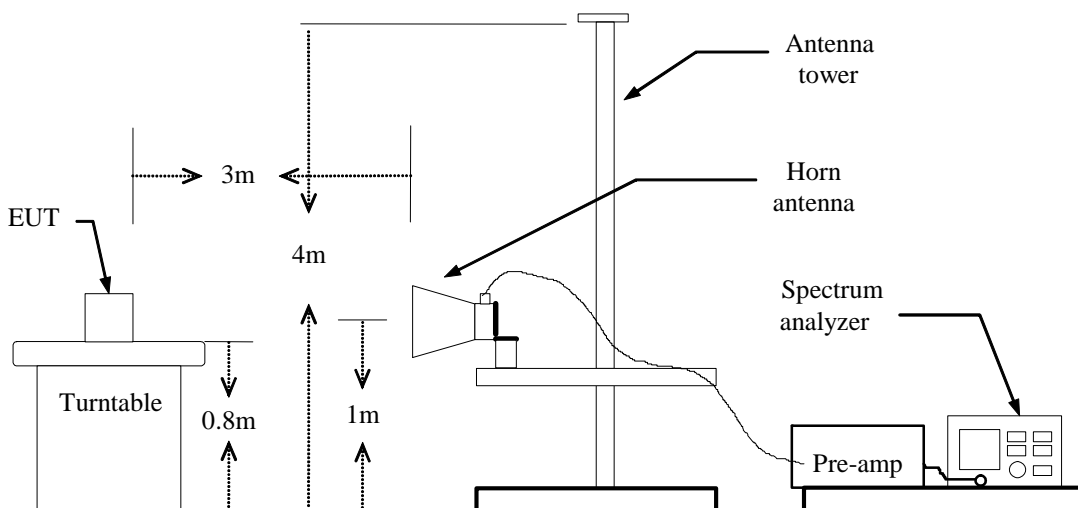

For Substituted Method Test Set-UP

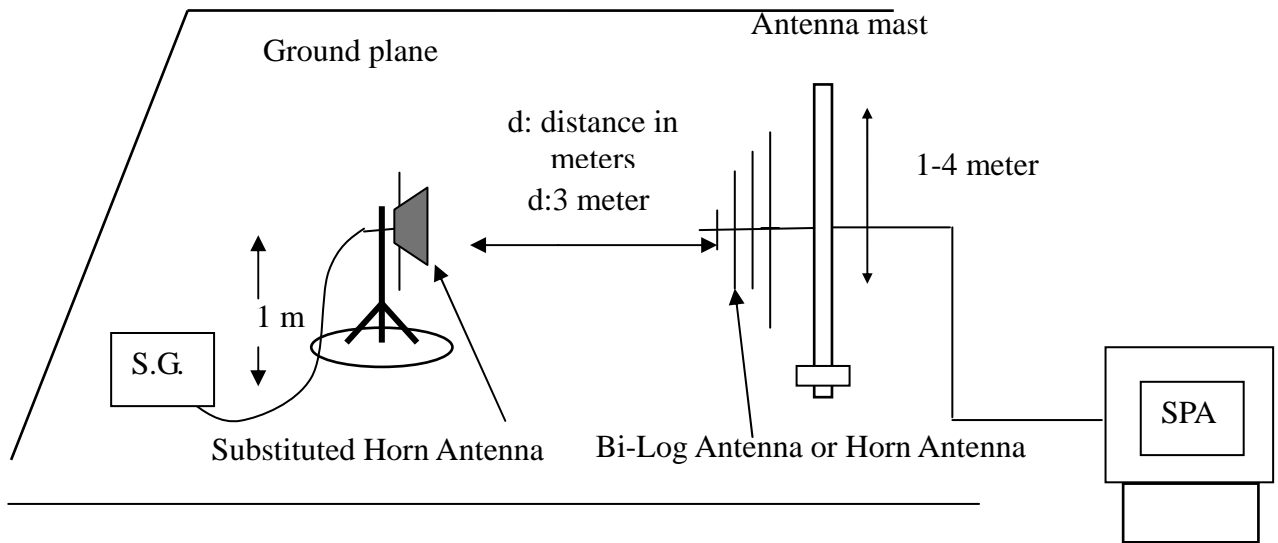

TEST PROCEDURE

The EUT was placed on a non-conductive turntable using a non-conductive support. The radiated emission at the fundamental frequency was measured at 3 m with a test antenna and EMI spectrum analyzer.

During the measurement of the EUT, the resolution bandwidth was set to 3MHz and the average bandwidth was set to 3MHz. The highest emission was recorded with the rotation of the turntable and the lowering of the test antenna. The reading was recorded and the field strength (E in dBuV/m) was calculated.

ERP in frequency band 824-849MHz, and EIRP in frequency band 1851.25 –1910MHz were measured using a substitution method. The EUT was replaced by half-wave dipole (824-849MHz) or horn antenna (1851.25-1910MHz) connected to a signal generator. The spectrum analyzer reading was recorded and ERP/EIRP was calculated as follows:

$$ERP = \text{S.G. output (dBm)} + \text{Antenna Gain (dBd)} - \text{Cable (dB)}$$

$$EIRP = \text{S.G. output (dBm)} + \text{Antenna Gain (dBi)} - \text{Cable (dB)}$$



TEST RESULTS

No non-compliance noted.

CDMA2000 1xRTT Cellular Test Data - Close Mode

EUT Pol.	Channel	Frequency (MHz)	Reading level (dBuV)	Antenna Pol.	Correction Factor (dB)	Result (dBm)	Limit (dBm)	Margin (dB)
X	1013	824.80	-23.92	V	34.61	10.69	38.5	-27.81
		824.80	-11.44	H	34.65	23.20	38.5	-15.30
	384	836.50	-21.97	V	34.53	12.56	38.5	-25.94
		836.50	-11.50	H	34.63	23.13	38.5	-15.37
	777	848.40	-21.35	V	34.63	13.28	38.5	-25.22
		848.30	-13.07	H	34.74	21.67	38.5	-16.83
Y	1013	824.70	-24.98	V	34.61	9.64	38.5	-28.86
		824.70	-11.56	H	34.65	23.09	38.5	-15.41
	384	836.60	-26.14	V	34.53	8.39	38.5	-30.11
		836.30	-11.45	H	34.63	23.18	38.5	-15.32
	777	848.30	-26.14	V	34.63	8.49	38.5	-30.01
		848.30	-12.81	H	34.74	21.93	38.5	-16.57
Z	1013	824.70	-11.49	V	34.62	23.12	38.5	-15.38
		824.70	-20.84	H	34.65	13.80	38.5	-24.70
	384	836.40	-11.64	V	34.52	22.89	38.5	-15.61
		836.40	-19.84	H	34.63	14.79	38.5	-23.71
	777	848.10	-13.05	V	34.63	21.58	38.5	-16.92
		848.10	-20.60	H	34.74	14.14	38.5	-24.36

**CDMA2000 1xRTT Cellular Test Data – Slide Mode**

EUT Pol.	Channel	Frequency (MHz)	Reading level (dBuV)	Antenna Pol.	Correction Factor (dB)	Result (dBm)	Limit (dBm)	Margin (dB)
X	1013	824.80	-21.93	V	34.62	12.68	38.5	-25.82
		824.80	-10.88	H	34.65	*23.76	38.5	-14.74
	384	836.50	-22.44	V	34.52	12.08	38.5	-26.42
		836.50	-11.93	H	34.63	22.70	38.5	-15.80
	777	848.30	-22.84	V	34.63	11.79	38.5	-26.71
		848.30	-13.59	H	34.74	21.15	38.5	-17.35
Y	1013	824.70	-21.75	V	34.61	12.86	38.5	-25.64
		824.70	-11.88	H	34.65	22.76	38.5	-15.74
	384	836.60	-21.83	V	34.53	12.70	38.5	-25.80
		836.60	-12.16	H	34.63	22.47	38.5	-16.03
	777	848.30	-22.39	V	34.63	12.24	38.5	-26.26
		848.30	-12.65	H	34.75	22.09	38.5	-16.41
Z	1013	824.70	-12.22	V	34.61	22.39	38.5	-16.11
		824.70	-17.55	H	34.65	17.10	38.5	-21.40
	384	836.50	-12.24	V	34.52	22.29	38.5	-16.21
		836.50	-17.80	H	34.63	16.83	38.5	-21.67
	777	848.10	-13.97	V	34.63	20.65	38.5	-17.85
		848.10	-19.43	H	34.74	15.31	38.5	-23.19

**CDMA2000 1xEVDO Cellular Test Data – Close Mode**

EUT Pol.	Channel	Frequency (MHz)	Reading level (dBuV)	Antenna Pol.	Correction Factor (dB)	Result (dBm)	Limit (dBm)	Margin (dB)
X	1013	848.10	-23.68	V	34.62	10.94	38.5	-27.56
		848.10	-10.64	H	34.65	24.01	38.5	-14.49
	384	836.40	-23.11	V	34.53	11.42	38.5	-27.08
		836.40	-10.14	H	34.63	*24.49	38.5	-14.01
	777	848.20	-24.09	V	34.63	10.54	38.5	-27.96
		848.20	-11.54	H	34.74	23.20	38.5	-15.30
Y	1013	824.60	-10.78	V	34.65	23.87	38.5	-14.63
		824.60	-24.39	H	34.61	10.22	38.5	-28.28
	384	836.50	-24.22	V	34.53	10.31	38.5	-28.19
		836.50	-11.07	H	34.63	23.56	38.5	-14.94
	777	848.20	-24.44	V	34.63	10.18	38.5	-28.32
		848.20	-11.90	H	34.74	22.84	38.5	-15.66
Z	1013	824.60	-11.29	V	34.61	23.32	38.5	-15.18
		824.60	-20.89	H	34.65	13.76	38.5	-24.74
	384	836.40	-11.09	V	34.52	23.43	38.5	-15.07
		836.40	-20.07	H	34.63	14.56	38.5	-23.94
	777	848.10	-12.20	V	34.63	22.44	38.5	-16.06
		848.10	-20.63	H	34.74	14.11	38.5	-24.39



CDMA2000 1xEVDO Cellular Test Data – Slide Mode

EUT Pol.	Channel	Frequency (MHz)	Reading level (dBuV)	Antenna Pol.	Correction Factor (dB)	Result (dBm)	Limit (dBm)	Margin (dB)
X	1013	848.10	-22.96	V	34.62	11.66	38.5	-26.84
		848.10	-10.52	H	34.65	24.13	38.5	-14.37
	384	836.20	-22.04	V	34.53	12.48	38.5	-26.02
		836.20	-11.13	H	34.63	23.50	38.5	-15.00
	777	848.30	-22.40	V	34.63	12.23	38.5	-26.27
		848.30	-13.10	H	34.74	21.64	38.5	-16.86
Y	1013	824.70	-21.89	V	34.62	12.72	38.5	-25.78
		824.70	-11.38	H	34.65	23.26	38.5	-15.24
	384	836.40	-21.23	V	34.53	13.30	38.5	-25.20
		836.40	-11.85	H	34.63	22.79	38.5	-15.71
	777	848.10	-21.46	V	34.63	13.17	38.5	-25.33
		848.10	-12.91	H	34.74	21.83	38.5	-16.67
Z	1013	824.70	-12.18	V	34.62	22.44	38.5	-16.06
		824.70	-16.32	H	34.65	18.33	38.5	-20.17
	384	836.50	-11.63	V	34.53	22.90	38.5	-15.60
		836.50	-16.58	H	34.63	18.05	38.5	-20.45
	777	848.10	-13.36	V	34.63	21.26	38.5	-17.24
		848.10	-19.04	H	34.74	15.70	38.5	-22.80



CDMA2000 1xRTT PCS Test Data – Close Mode

EUT Pol.	Channel	Frequency (MHz)	Reading level (dBuV)	Antenna Pol.	Correction Factor (dB)	Result (dBm)	Limit (dBm)	Margin (dB)
X	25	1851.15	-27.44	V	41.17	13.73	33.00	-19.27
		1851.15	-19.44	H	40.80	21.36	33.00	-11.64
	600	1879.95	-25.78	V	41.23	15.45	33.00	-17.55
		1879.95	-17.22	H	41.14	23.92	33.00	-9.08
	1175	1908.90	-26.07	V	41.30	15.23	33.00	-17.77
		1908.90	-17.45	H	41.38	23.93	33.00	-9.07
Y	25	1851.00	-20.48	V	41.17	20.69	33.00	-12.31
		1851.00	-19.46	H	40.80	21.34	33.00	-11.66
	600	1879.95	-19.64	V	41.23	21.59	33.00	-11.41
		1879.95	-18.27	H	41.14	22.87	33.00	-10.13
	1175	1908.90	-20.23	V	41.30	21.07	33.00	-11.93
		1908.90	-17.42	H	41.38	23.96	33.00	-9.04
Z	25	1851.30	-19.50	V	41.17	21.67	33.00	-11.33
		1851.30	-21.28	H	40.80	19.52	33.00	-13.48
	600	1879.80	-18.88	V	41.23	22.35	33.00	-10.65
		1879.80	-20.72	H	41.14	20.42	33.00	-12.58
	1175	1908.60	-18.57	V	41.30	22.72	33.00	-10.28
		1908.60	-19.86	H	41.38	21.51	33.00	-11.49

**CDMA2000 1xRTT PCS Test Data – Slide Mode**

EUT Pol.	Channel	Frequency (MHz)	Reading level (dBuV)	Antenna Pol.	Correction Factor (dB)	Result (dBm)	Limit (dBm)	Margin (dB)
X	25	1851.30	-28.35	V	41.17	12.83	33.00	-20.17
		1851.30	-19.54	H	40.80	21.26	33.00	-11.74
	600	1880.10	-26.23	V	41.23	14.99	33.00	-18.01
		1880.10	-17.37	H	41.14	23.78	33.00	-9.22
	1175	1908.75	-26.79	V	41.30	14.51	33.00	-18.49
		1908.75	-17.06	H	41.38	*24.31	33.00	-8.69
Y	25	1851.15	-21.66	V	41.17	19.51	33.00	-13.49
		1851.15	-21.62	H	40.80	19.18	33.00	-13.82
	600	1880.10	-19.77	V	41.23	21.46	33.00	-11.54
		1880.10	-19.40	H	41.15	21.74	33.00	-11.26
	1175	1908.75	-19.47	V	41.30	21.83	33.00	-11.17
		1908.75	-18.70	H	41.38	22.68	33.00	-10.32
Z	25	1851.15	-20.58	V	41.17	20.60	33.00	-12.40
		1851.15	-20.94	H	40.80	19.87	33.00	-13.13
	600	1879.95	-19.97	V	41.23	21.26	33.00	-11.74
		1879.95	-18.71	H	41.14	22.44	33.00	-10.56
	1175	1908.60	-18.62	V	41.30	22.67	33.00	-10.33
		1908.60	-18.34	H	41.38	23.04	33.00	-9.96

**CDMA2000 1xEVDO PCS Test Data – Close Mode**

EUT Pol.	Channel	Frequency (MHz)	Reading level (dBuV)	Antenna Pol.	Correction Factor (dB)	Result (dBm)	Limit (dBm)	Margin (dB)
X	25	1851.30	-26.70	V	41.17	14.47	33.00	-18.53
		1851.30	-19.07	H	40.81	21.73	33.00	-11.27
	600	1880.10	-24.76	V	41.23	16.47	33.00	-16.53
		1880.10	-17.56	H	41.14	23.59	33.00	-9.41
	1175	1908.60	-24.83	V	41.30	16.47	33.00	-16.53
		1908.60	-17.16	H	41.38	*24.22	33.00	-8.78
Y	25	1851.15	-20.46	V	41.17	20.71	33.00	-12.29
		1851.15	-19.64	H	40.81	21.16	33.00	-11.84
	600	1879.95	-19.24	V	41.23	21.99	33.00	-11.01
		1879.95	-18.43	H	41.14	22.71	33.00	-10.29
	1175	1908.60	-19.58	V	41.30	21.72	33.00	-11.28
		1908.60	-18.14	H	41.38	23.23	33.00	-9.77
Z	25	1851.15	-19.66	V	41.17	21.51	33.00	-11.49
		1851.15	-20.50	H	40.81	20.31	33.00	-12.69
	600	1879.95	-19.57	V	41.23	21.66	33.00	-11.34
		1879.95	-19.87	H	41.15	21.27	33.00	-11.73
	1175	1908.45	-19.21	V	41.30	22.09	33.00	-10.91
		1908.45	-20.80	H	41.38	20.57	33.00	-12.43



CDMA2000 1xEVDO PCS Test Data – Slide Mode

EUT Pol.	Channel	Frequency (MHz)	Reading level (dBuV)	Antenna Pol.	Correction Factor (dB)	Result (dBm)	Limit (dBm)	Margin (dB)
X	25	1851.15	-27.05	V	41.17	14.12	33.00	-18.88
		1851.15	-19.84	H	40.81	20.97	33.00	-12.03
	600	1880.10	-24.82	V	41.23	16.41	33.00	-16.59
		1880.10	-17.96	H	41.15	23.19	33.00	-9.81
	1175	1908.75	-24.85	V	41.30	16.45	33.00	-16.55
		1908.75	-17.17	H	41.38	24.21	33.00	-8.79
Y	25	1851.30	-21.69	V	41.17	19.49	33.00	-13.51
		1851.30	-21.55	H	40.80	19.25	33.00	-13.75
	600	1879.95	-19.62	V	41.23	21.61	33.00	-11.39
		1879.95	-19.57	H	41.14	21.58	33.00	-11.42
	1175	1908.75	-18.82	V	41.30	22.48	33.00	-10.52
		1908.75	-18.98	H	41.38	22.40	33.00	-10.60
Z	25	1851.30	-20.43	V	41.17	20.74	33.00	-12.26
		1851.30	-19.74	H	40.81	21.07	33.00	-11.93
	600	1880.10	-19.03	V	41.23	22.20	33.00	-10.80
		1880.10	-18.62	H	41.14	22.52	33.00	-10.48
	1175	1908.45	-18.75	V	41.30	22.54	33.00	-10.46
		1908.45	-18.74	H	41.38	22.63	33.00	-10.37



7.3 OCCUPIED BANDWIDTH MEASUREMENT

LIMIT

According to §FCC 2.1049.

Test Configuration

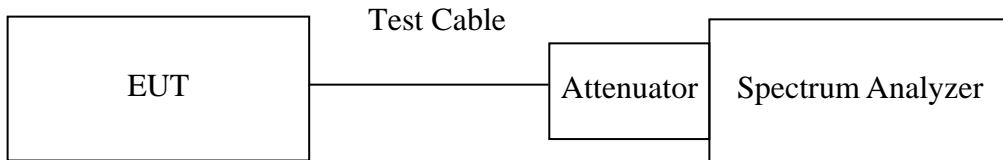

Remark: Measurement setup for testing on Antenna connector

TEST PROCEDURE

The EUT’s output RF connector was connected with a short cable to the spectrum analyzer, RBW was set to about 1% of emission BW, VBW is set to 3 times the RBW, -26dBc display line was placed on the screen (or 99% bandwidth), the occupied bandwidth is the delta frequency between the two points where the display line intersects the signal trace.

TEST RESULTS

No non-compliance noted.

Test Data

Test Mode	CH	Frequency (MHz)	Bandwidth (MHz)
CDMA2000 1xRTT Cellular	1013	824.70	1.2807
	384	836.52	1.2770
	777	848.31	1.2844
CDMA2000 1xEVDO Cellular	1013	824.70	1.2807
	384	836.52	1.2774
	777	848.31	1.2765

Test Mode	CH	Frequency (MHz)	Bandwidth (MHz)
CDMA2000 1xRTT PCS	25	1851.25	1.2708
	600	1880.00	1.2742
	1175	1908.75	1.2747
CDMA2000 1xEVDO PCS	25	1851.25	1.2720
	600	1880.00	1.2835
	1175	1908.75	1.2771



Test Plot

CDMA2000 1xRTT Cellular / CH Low

Agilent 20:07:20 Sep 17, 2009

R T

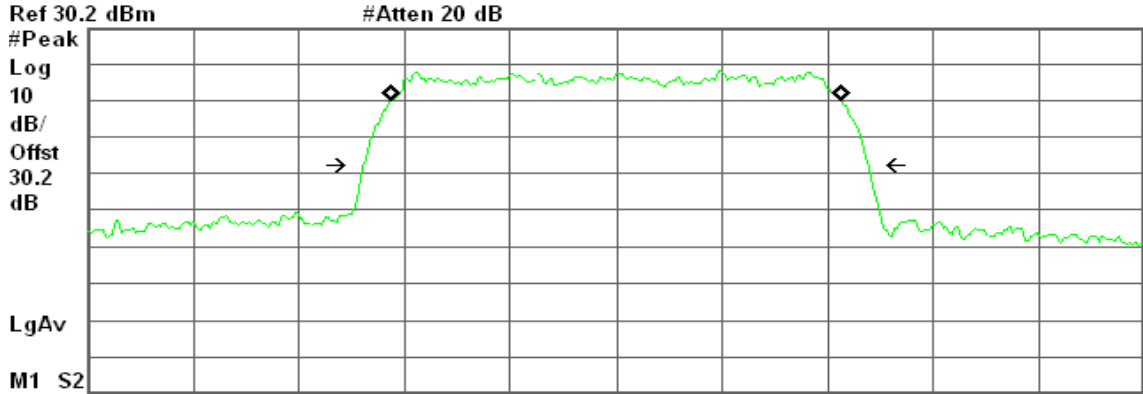

Center 824.700 MHz Span 3 MHz
 #Res BW 30 kHz #VBW 100 kHz Sweep 3.2 ms (601 pts)

Occupied Bandwidth
 1.2807 MHz

Occ BW % Pwr 99.00 %
 x dB -26.00 dB

Transmit Freq Error 1.258 kHz
 x dB Bandwidth 1.436 MHz

CDMA2000 1xRTT Cellular / CH Mid

Agilent 20:02:15 Sep 17, 2009

R T

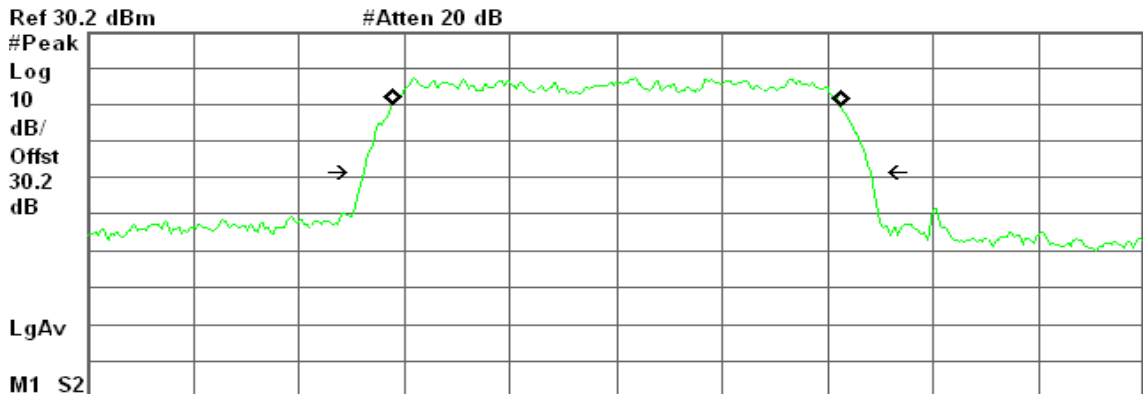

Center 836.520 MHz Span 3 MHz
 #Res BW 30 kHz #VBW 100 kHz Sweep 3.2 ms (601 pts)

Occupied Bandwidth
 1.2770 MHz

Occ BW % Pwr 99.00 %
 x dB -26.00 dB

Transmit Freq Error 2.367 kHz
 x dB Bandwidth 1.441 MHz



CDMA2000 1xRTT Cellular / CH High

Agilent 20:06:49 Sep 17, 2009

R T

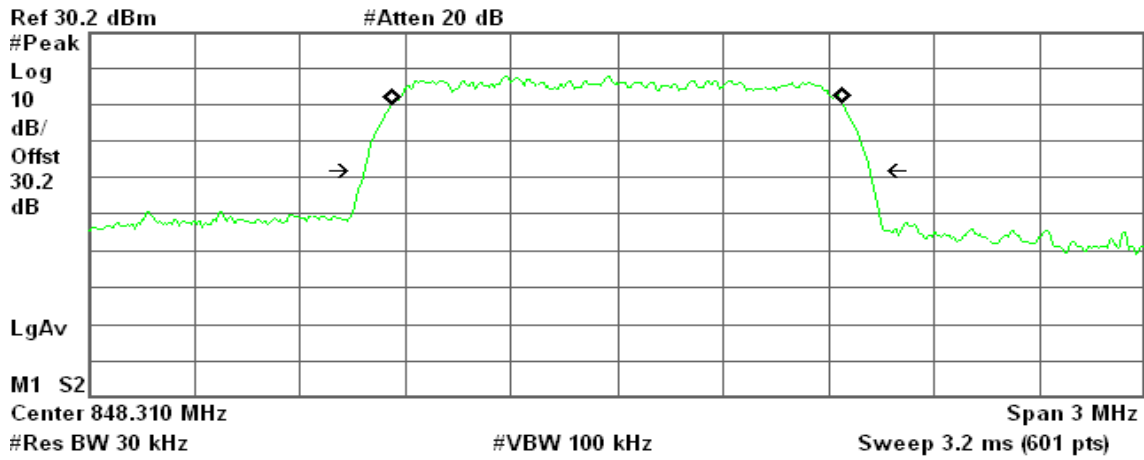

Occupied Bandwidth
1.2844 MHz

Occ BW % Pwr 99.00 %
x dB -26.00 dB

Transmit Freq Error 248.011 Hz
x dB Bandwidth 1.436 MHz

CDMA2000 1xEVDO Cellular / CH Low

Agilent 20:07:20 Sep 17, 2009

R T

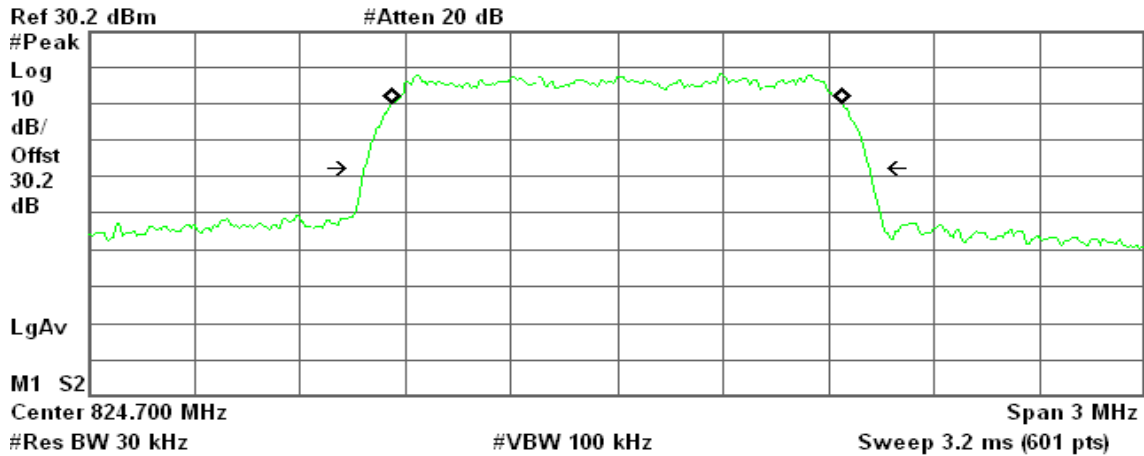

Occupied Bandwidth
1.2807 MHz

Occ BW % Pwr 99.00 %
x dB -26.00 dB

Transmit Freq Error 1.258 kHz
x dB Bandwidth 1.436 MHz



CDMA2000 1xEVDO Cellular / CH Mid

Agilent 21:10:51 Sep 17, 2009

R T

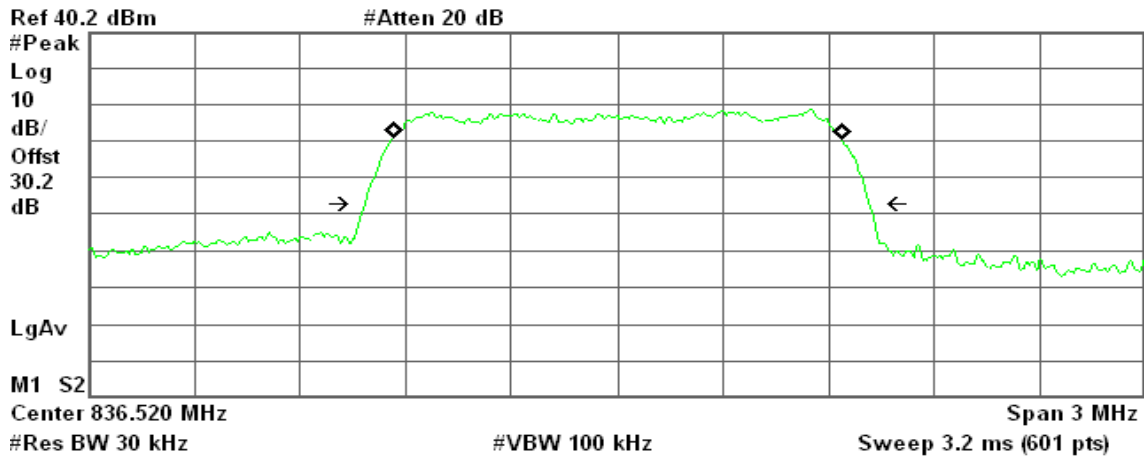

Occupied Bandwidth
1.2774 MHz

Occ BW % Pwr 99.00 %
x dB -26.00 dB

Transmit Freq Error 1.412 kHz
x dB Bandwidth 1.434 MHz

CDMA2000 1xEVDO Cellular / CH High

Agilent 21:11:56 Sep 17, 2009

R T

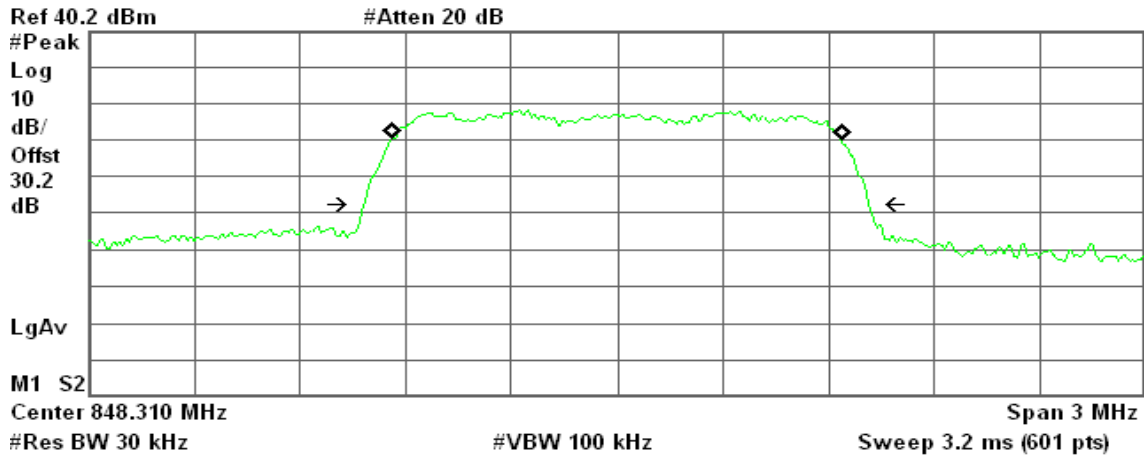

Occupied Bandwidth
1.2765 MHz

Occ BW % Pwr 99.00 %
x dB -26.00 dB

Transmit Freq Error -396.759 Hz
x dB Bandwidth 1.436 MHz



CDMA2000 1xRTT PCS / CH Low

Agilent 20:42:22 Sep 17, 2009

R T

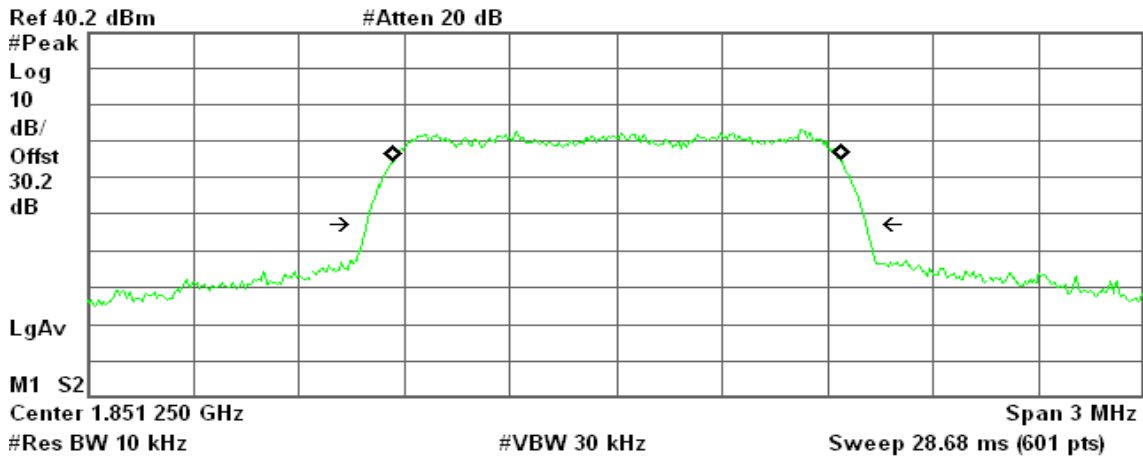

Occupied Bandwidth
1.2708 MHz

Occ BW % Pwr 99.00 %
x dB -26.00 dB

Transmit Freq Error 2.492 kHz
x dB Bandwidth 1.420 MHz

CDMA2000 1xRTT PCS / CH Mid

Agilent 20:43:26 Sep 17, 2009

R T

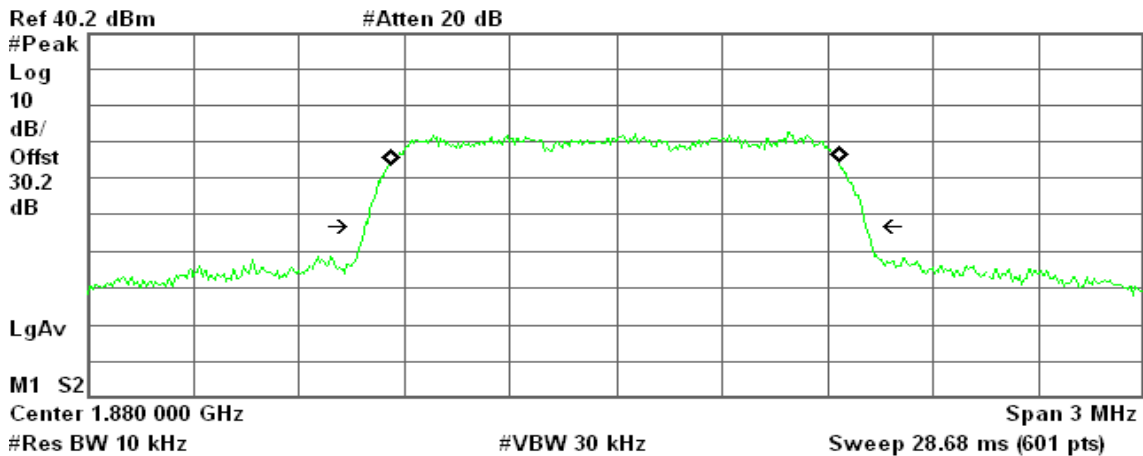

Occupied Bandwidth
1.2742 MHz

Occ BW % Pwr 99.00 %
x dB -26.00 dB

Transmit Freq Error -2.672 kHz
x dB Bandwidth 1.424 MHz



CDMA2000 1xRTT PCS / CH High

Agilent 20:44:53 Sep 17, 2009

R T

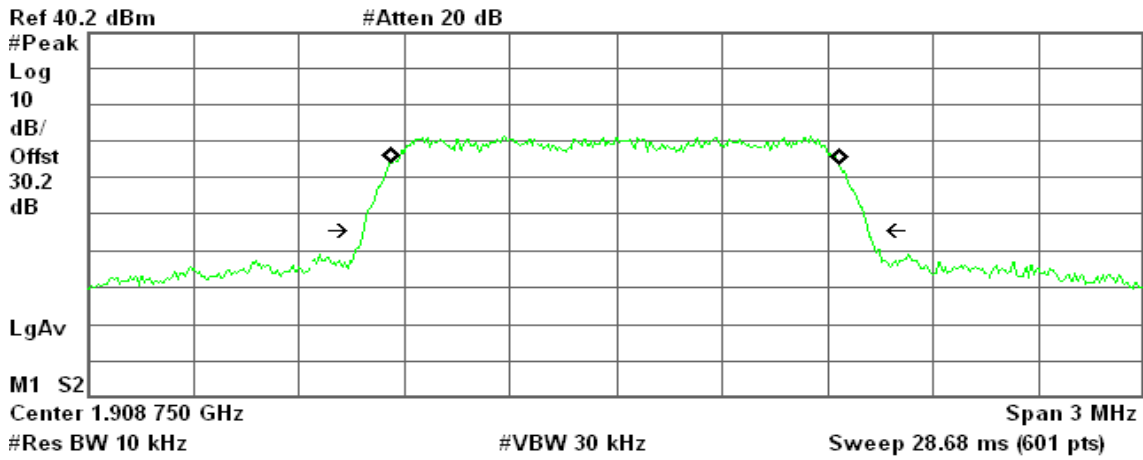

Occupied Bandwidth
1.2747 MHz

Occ BW % Pwr 99.00 %
x dB -26.00 dB

Transmit Freq Error -2.180 kHz
x dB Bandwidth 1.435 MHz

CDMA2000 1xEVDO PCS / CH Low

Agilent 21:50:18 Sep 17, 2009

R T

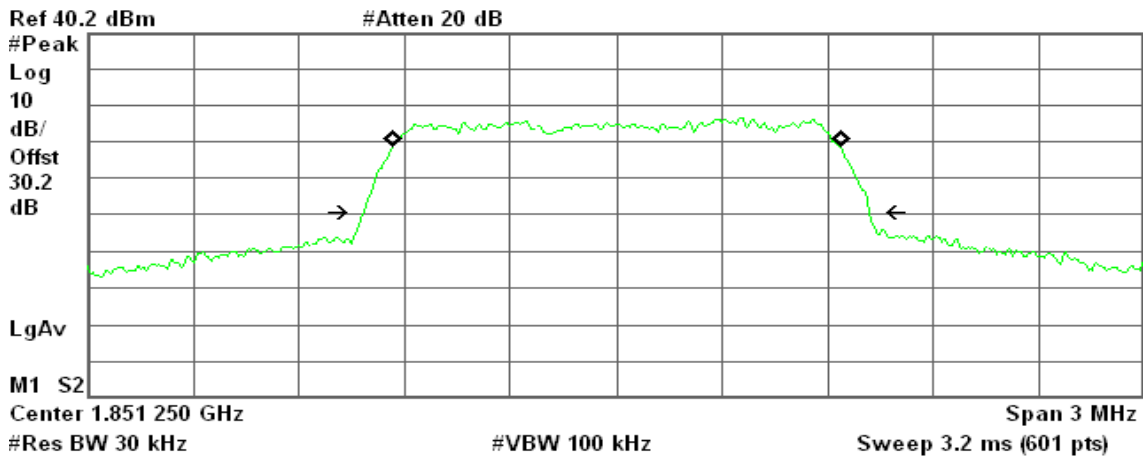

Occupied Bandwidth
1.2720 MHz

Occ BW % Pwr 99.00 %
x dB -26.00 dB

Transmit Freq Error 2.349 kHz
x dB Bandwidth 1.435 MHz



CDMA2000 1xEVDO PCS / CH Mid

Agilent 21:51:35 Sep 17, 2009

R T

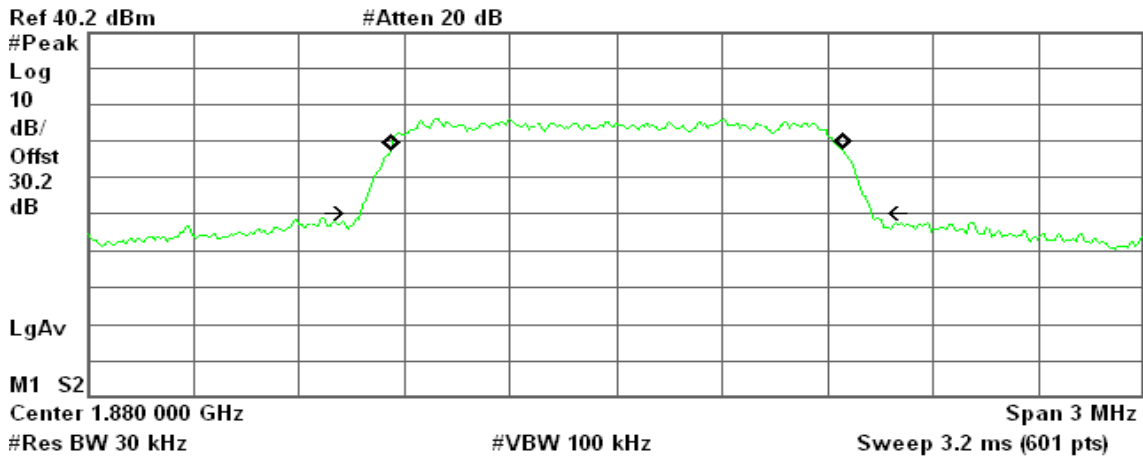

Occupied Bandwidth
1.2835 MHz

Occ BW % Pwr 99.00 %
x dB -26.00 dB

Transmit Freq Error 2.658 kHz
x dB Bandwidth 1.453 MHz

CDMA2000 1xEVDO PCS / CH High

Agilent 22:19:02 Sep 17, 2009

R T

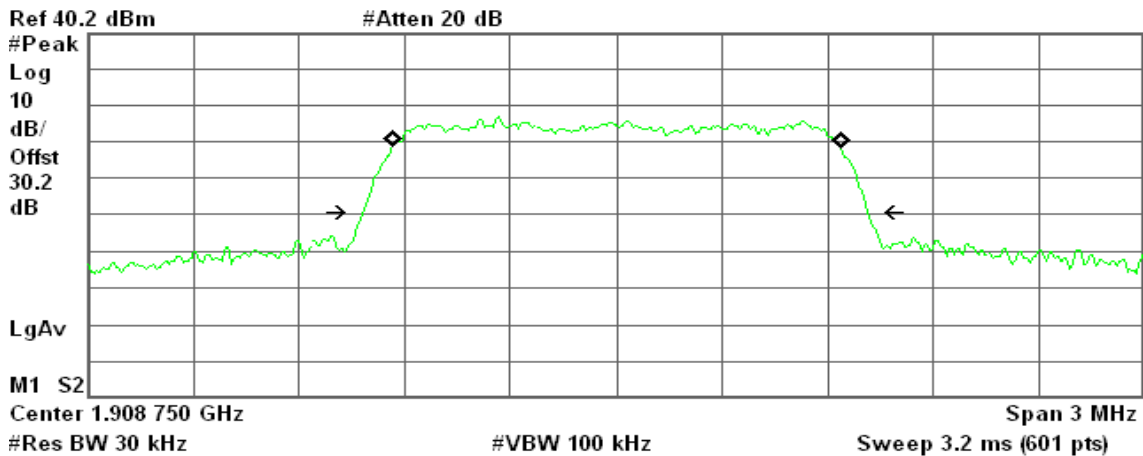

Occupied Bandwidth
1.2771 MHz

Occ BW % Pwr 99.00 %
x dB -26.00 dB

Transmit Freq Error 2.056 kHz
x dB Bandwidth 1.434 MHz



7.4 OUT OF BAND EMISSION AT ANTENNA TERMINALS

LIMIT

According to FCC §2.1051, FCC §22.917, FCC §24.238(a).

Out of Band Emissions: The mean power of emission must be attenuated below the mean power of the non-modulated carrier (P) on any frequency twice or more than twice the fundamental frequency by at least $43 + 10 \log P$ dB.

Mobile Emissions in Base Frequency Range: The mean power of any emissions appearing in the base station frequency range from cellular mobile transmitters operated must be attenuated to a level not exceed -80 dBm at the transmit antenna connector.

Band Edge Requirements: In the 1MHz bands immediately outside and adjacent to the frequency block, a resolution bandwidth of at least 1% of the emission bandwidth of the fundamental emission of the transmitter may be employed to measure the Out of band Emission

TEST CONFIGURATION

Out of band emission at antenna terminals:

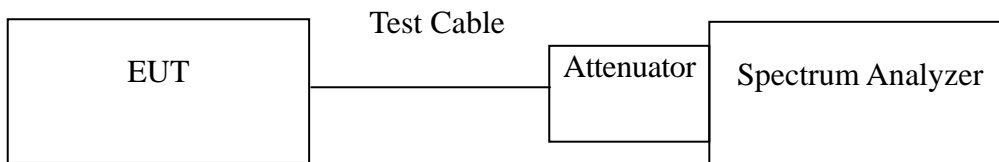

TEST PROCEDURE

The RF output of the transceiver was connected to a spectrum analyzer through appropriate attenuation. The resolution bandwidth of the spectrum analyzer was set at 1MHz, sufficient scans were taken to show the out of band Emissions if any up to 10th harmonic.

For the out of band: Set the RBW, VBW = 1MHz, Start=30MHz, Stop= 10 th harmonic. Limit = -13 dBm

Band Edge Requirements (824 MHz and 849 MHz /1850MHz and 1910MHz): In the 1 MHz bands immediately outside and adjacent to the frequency block, a resolution bandwidth of at least 1 percent of the emission bandwidth of the fundamental emission of the transmitter may be employed to measure the out of band Emissions. Limit, -13 dBm.

**TEST RESULTS***No non-compliance noted.***Test Data**

Mode	CH	Location	Description
CDMA2000 1xRTT Cellular	1013	Figure 7-1	Conducted spurious emissions, 30MHz - 20GHz
	777	Figure 7-2	Conducted spurious emissions, 30MHz - 20GHz
	384	Figure 7-3	Conducted spurious emissions, 30MHz - 20GHz
Mode	CH	Location	Description
CDMA2000 1xEVDO Cellular	1013	Figure 8-1	Conducted spurious emissions, 30MHz - 20GHz
	777	Figure 8-2	Conducted spurious emissions, 30MHz - 20GHz
	384	Figure 8-3	Conducted spurious emissions, 30MHz - 20GHz
Mode	CH	Location	Description
CDMA2000 1xRTT PCS	25	Figure 9-1	Conducted spurious emissions, 30MHz - 20GHz
	600	Figure 9-2	Conducted spurious emissions, 30MHz - 20GHz
	1175	Figure 9-3.	Conducted spurious emissions, 30MHz - 20GHz
Mode	CH	Location	Description
CDMA2000 1xEVDO PCS	25	Figure 10-1	Conducted spurious emissions, 30MHz - 20GHz
	600	Figure 10-2	Conducted spurious emissions, 30MHz - 20GHz
	1175	Figure 10-3.	Conducted spurious emissions, 30MHz - 20GHz
Mode	CH	Location	Description
CDMA2000 1xRTT Cellular	1013	Figure 11-1	Band Edge emissions
	384	Figure 11-2	Band Edge emissions
Mode	CH	Location	Description
CDMA2000 1xEVDO Cellular	1013	Figure 12-1	Band Edge emissions
	384	Figure 12-2	Band Edge emissions
Mode	CH	Location	Description
CDMA2000 1xRTT PCS	25	Figure 13-1	Band Edge emissions
	1175	Figure 13-2	Band Edge emissions
Mode	CH	Location	Description
CDMA2000 1xEVDO PCS	25	Figure 14-1	Band Edge emissions
	1175	Figure 14-2	Band Edge emissions



Test Plot

CDMA2000 1xRTT Cellular

Figure 7-1: Out of Band emission at antenna terminals – CDMA2000 1xRTT / CH Low

Agilent 20:24:12 Sep 17, 2009

R T

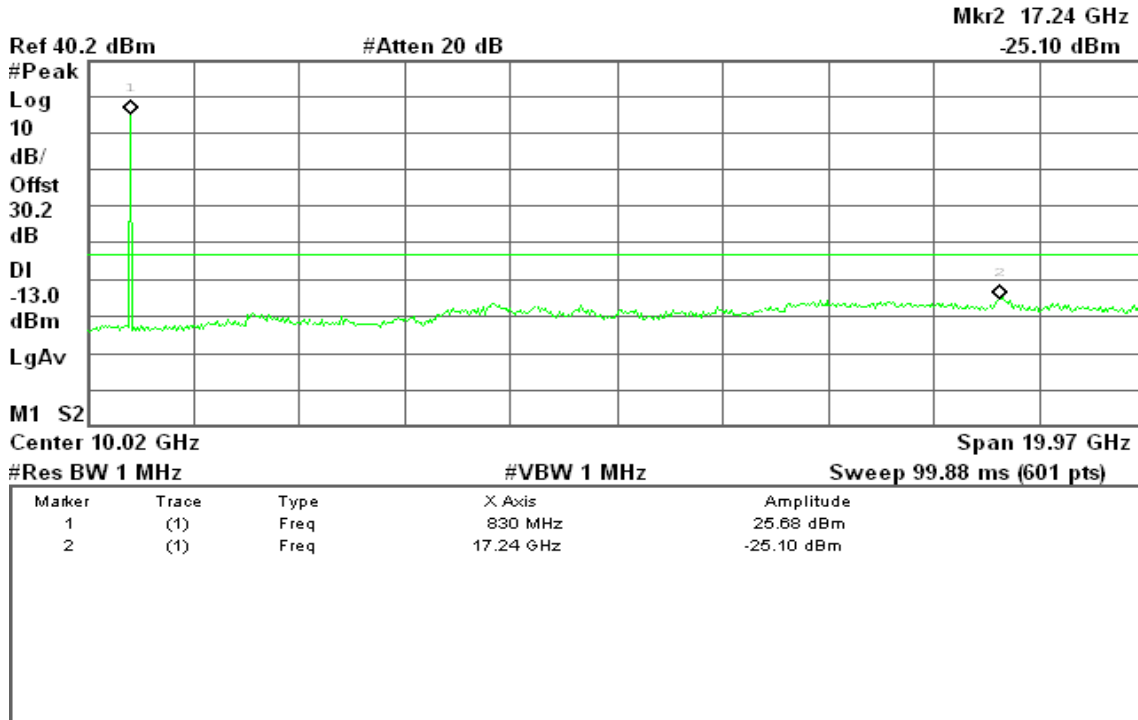

Figure 7-2: Out of Band emission at antenna terminals – CDMA2000 1xRTT / CH Mid

Agilent 20:23:34 Sep 17, 2009

R T

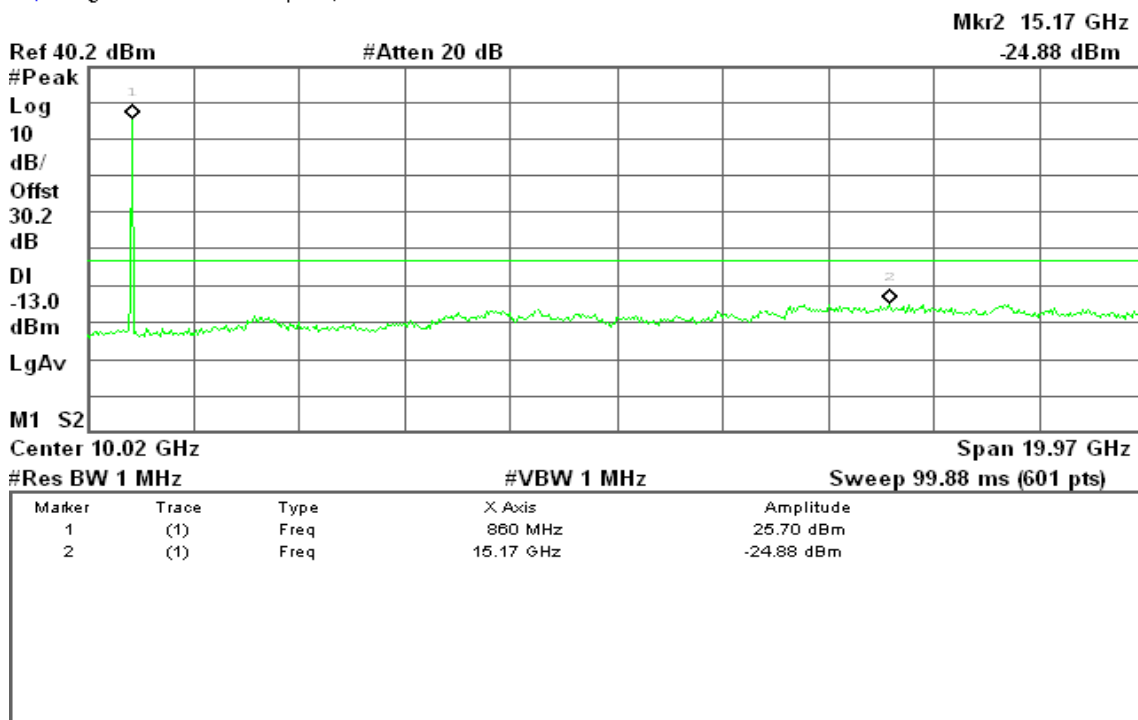
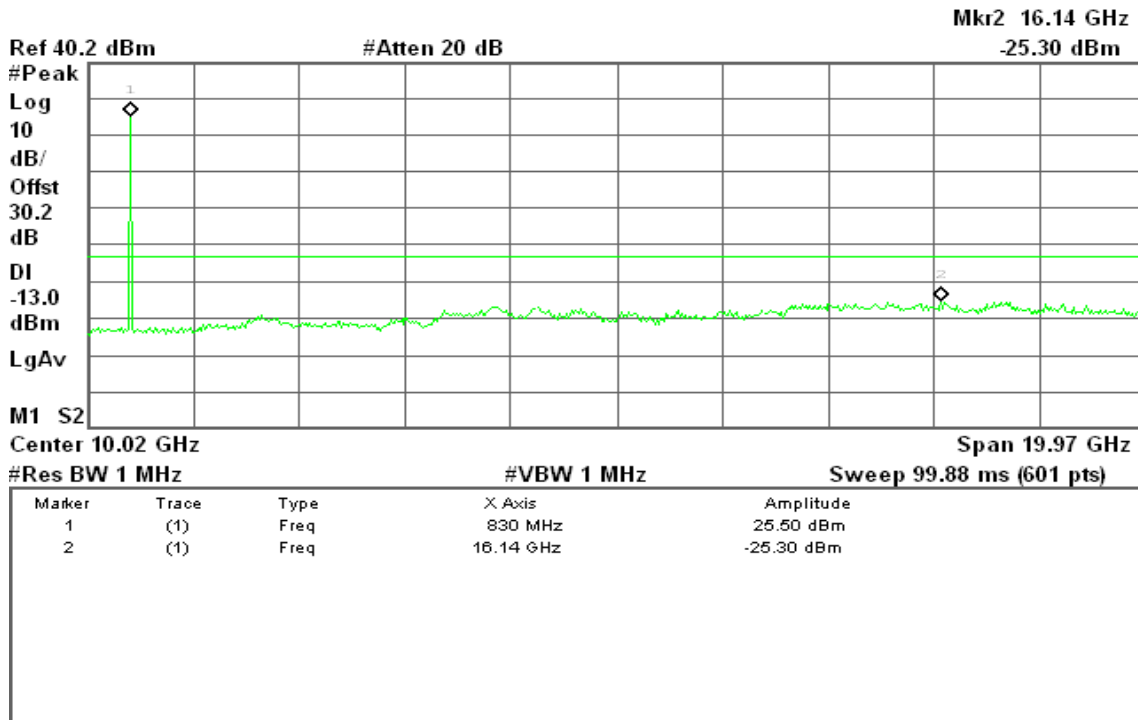



Figure 7-3: Out of Band emission at antenna terminals – CDMA2000 1xRTT / CH High

Agilent 20:24:39 Sep 17, 2009

R T



1xEVDO Cellular

Figure 8-1: Out of Band emission at antenna terminals – CDMA2000 1xEVDO / CH Low

Agilent 21:28:03 Sep 17, 2009

R T

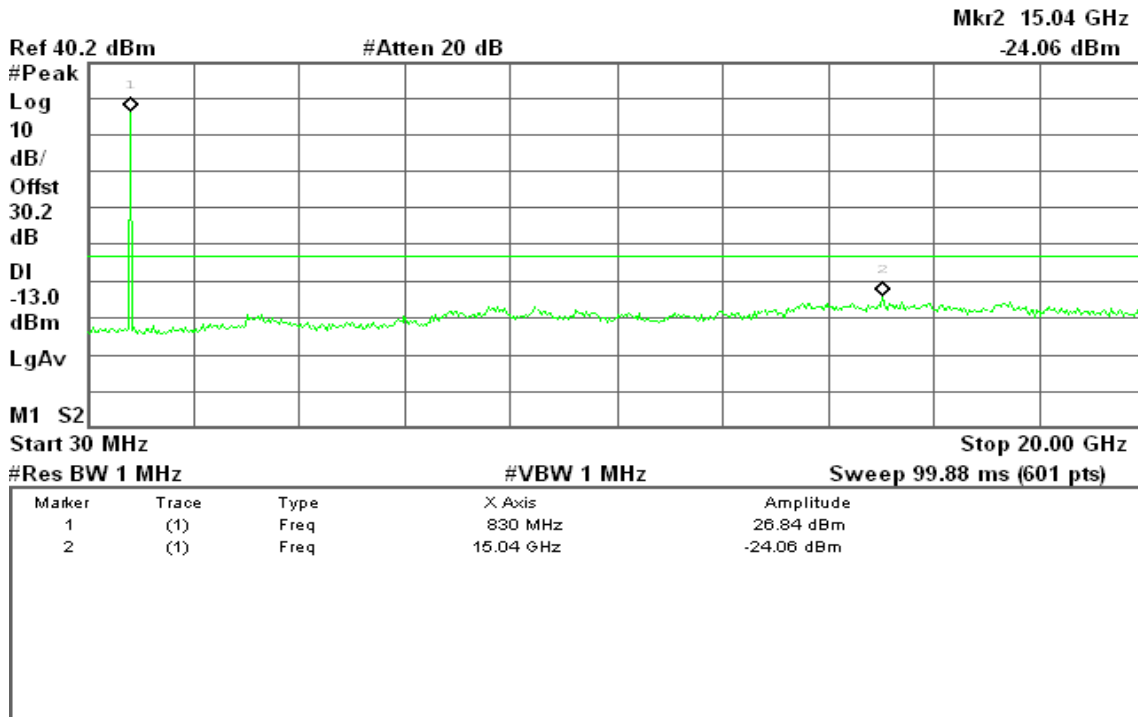



Figure 8-2: Out of Band emission at antenna terminals – CDMA2000 1xEVDO / CH Mid

Agilent 21:28:41 Sep 17, 2009

R T



Figure 8-3: Out of Band emission at antenna terminals – CDMA2000 1xEVDO / CH High

Agilent 21:29:18 Sep 17, 2009

R T

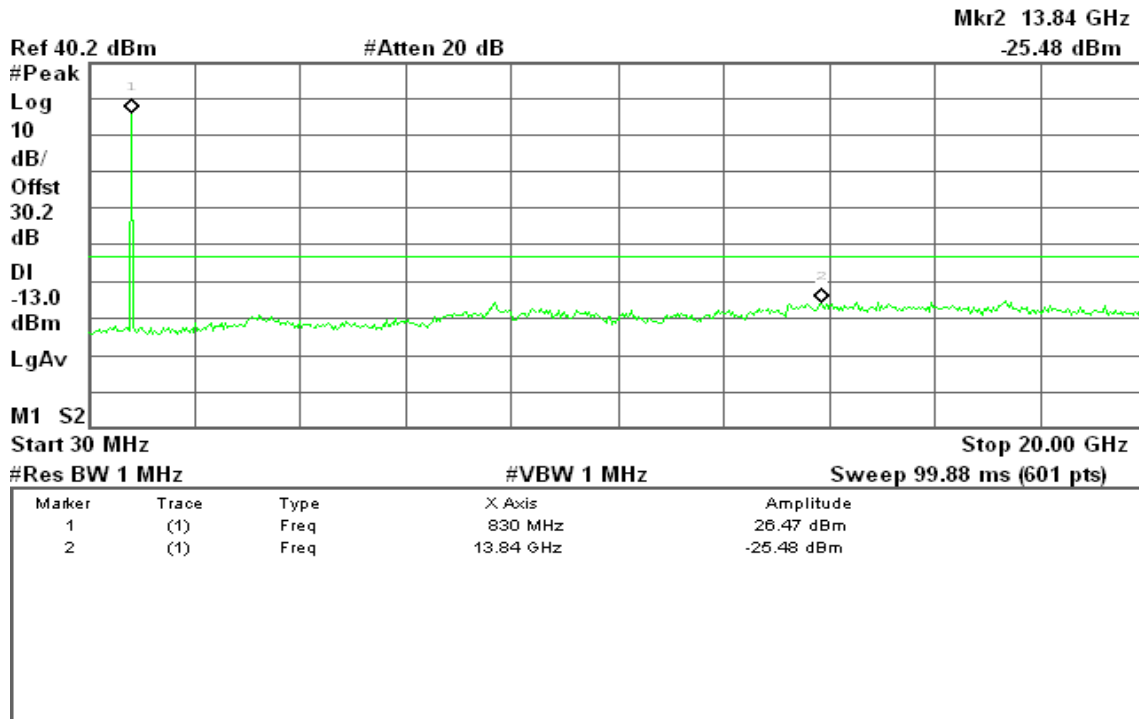



CDMA2000 1xRTT PCS

Figure 9-1: Out of Band emission at antenna terminals – CDMA2000 1xRTT / CH Low

Agilent 20:51:52 Sep 17, 2009

R T

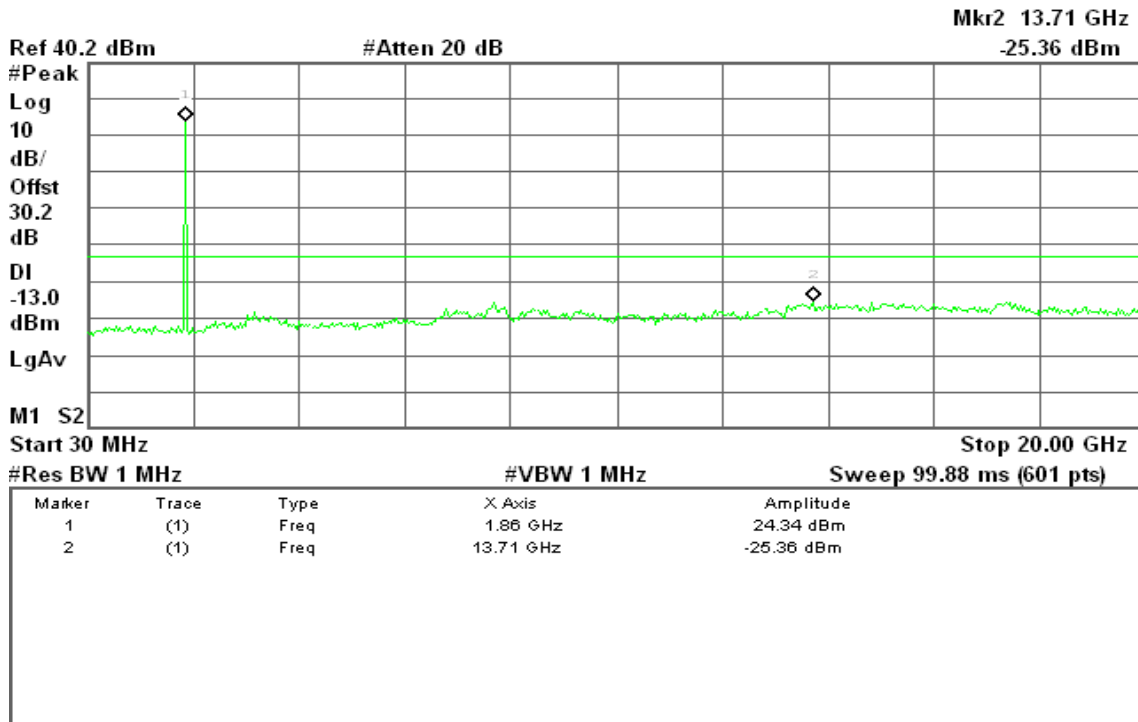

Figure 9-2: Out of Band emission at antenna terminals – CDMA2000 1xRTT / CH Mid

Agilent 20:50:27 Sep 17, 2009

R T

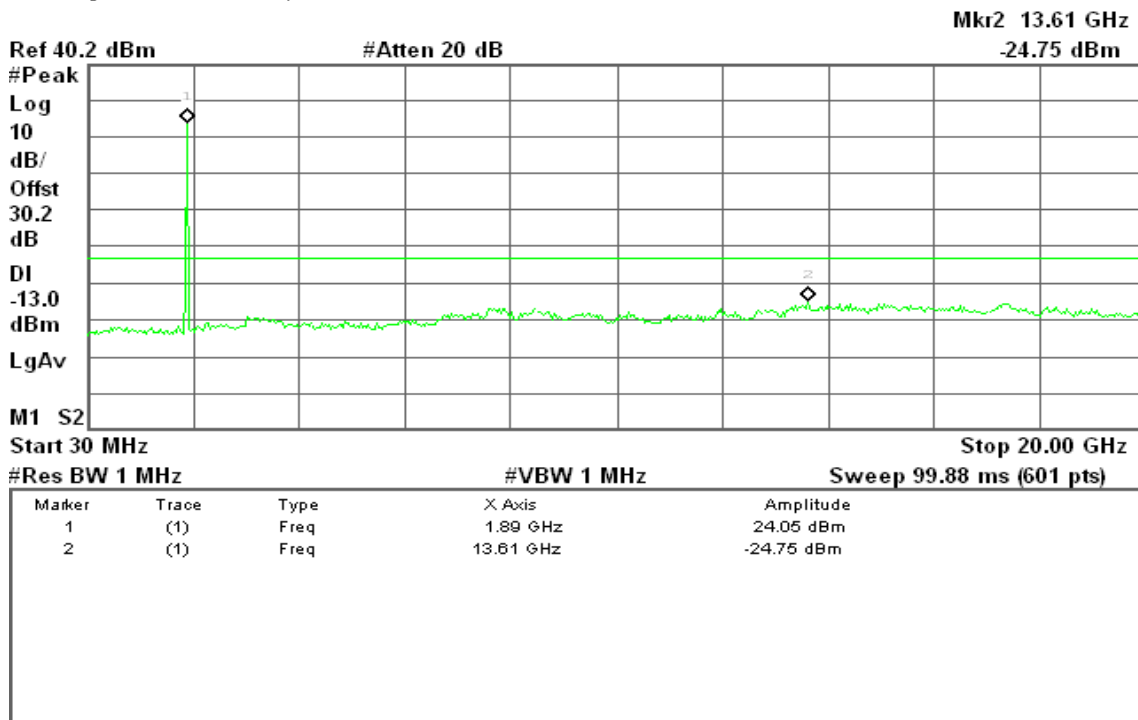
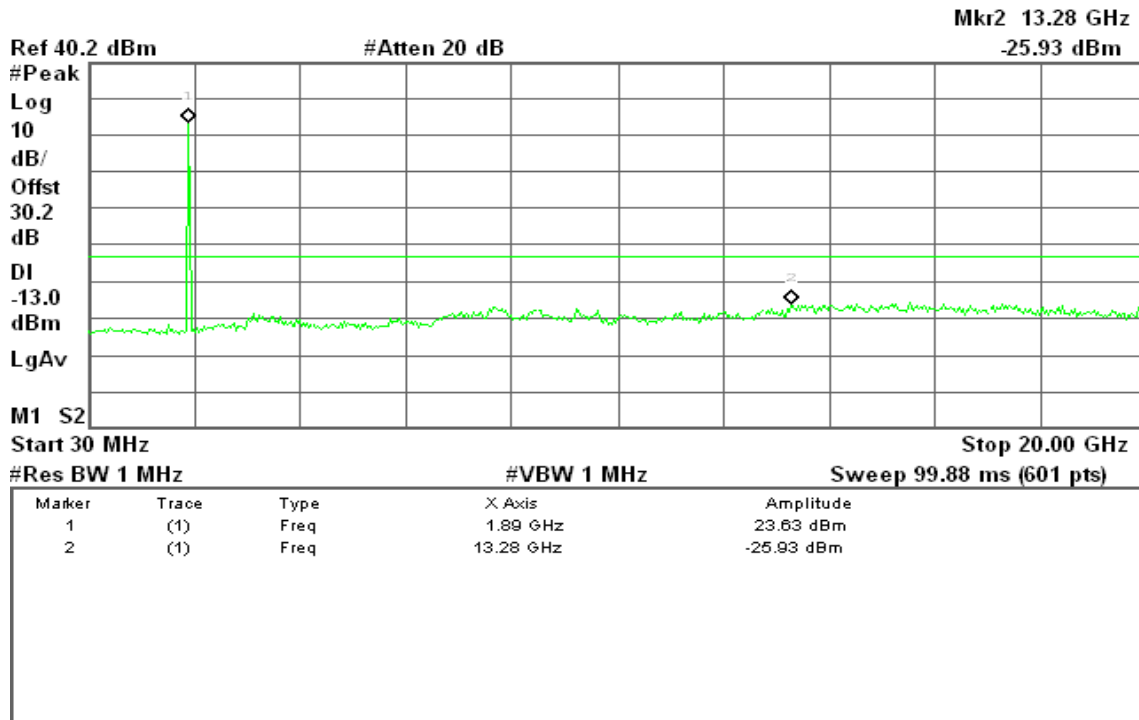



Figure 9-3: Out of Band emission at antenna terminals – CDMA2000 1xRTT / CH High

Agilent 20:51:19 Sep 17, 2009

R T



CDMA2000 1xEVDO PCS

Figure 10-1: Out of Band emission at antenna terminals – CDMA2000 1xEVDO / CH Low

Agilent 21:34:48 Sep 17, 2009

R T

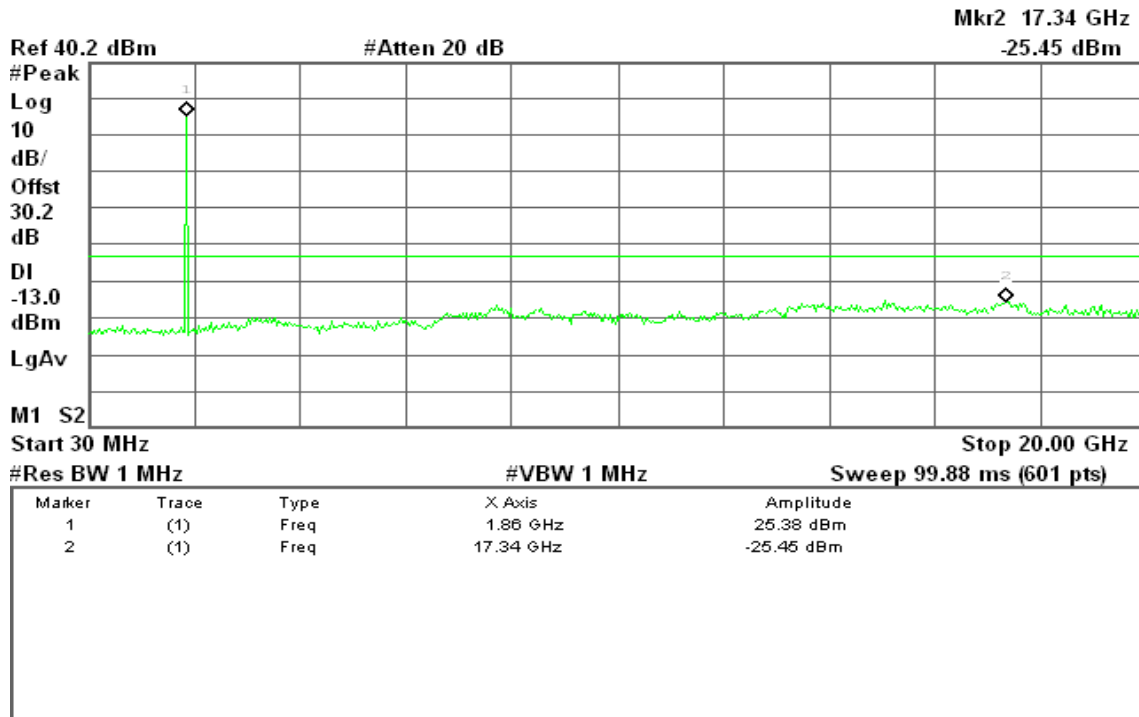



Figure 10-2: Out of Band emission at antenna terminals – CDMA2000 1xEVDO / CH Mid

Agilent 21:35:57 Sep 17, 2009

R T

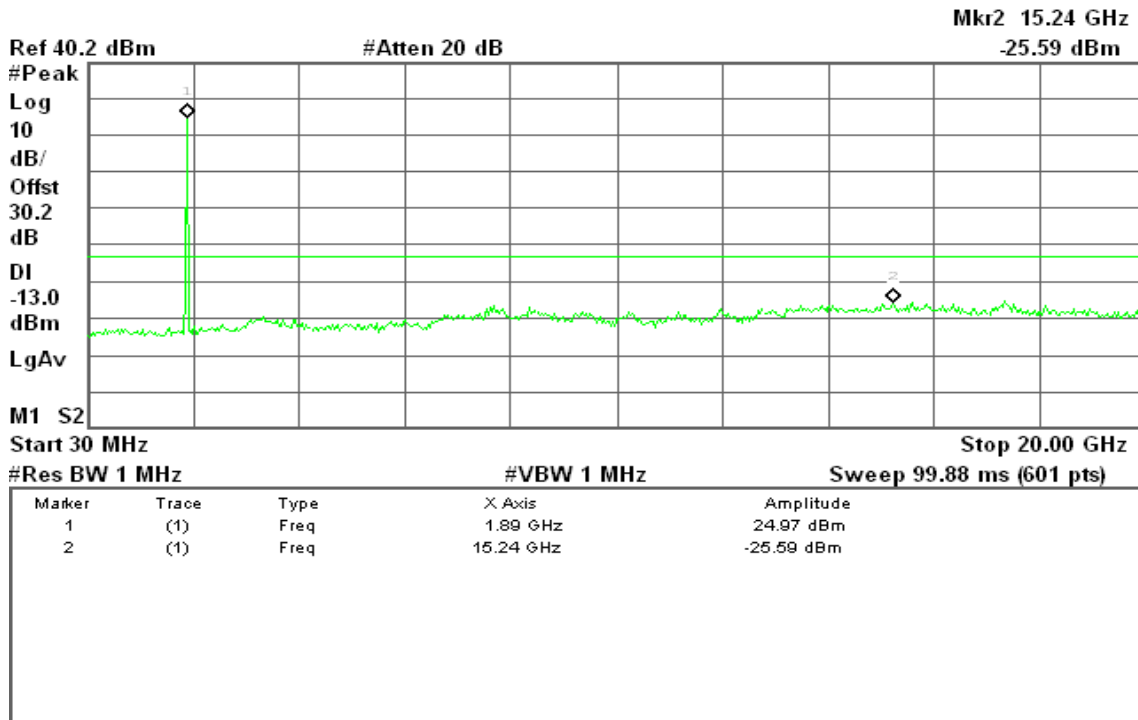
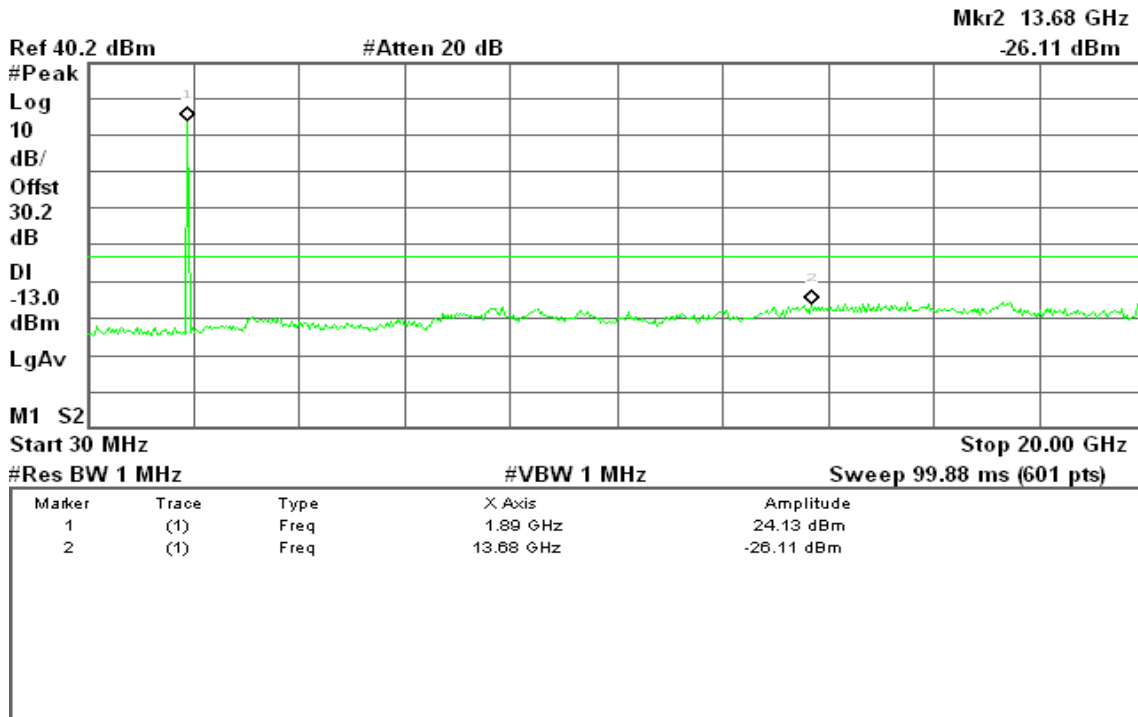

Figure 10-3: Out of Band emission at antenna terminals – CDMA2000 1xEVDO / CH High

Agilent 21:41:49 Sep 17, 2009

R T





CDMA2000 1xRTT Cellular

Figure 11-1: Band Edge emissions – CDMA2000 1xRTT / CH Low

Agilent 20:15:24 Sep 17, 2009

R T

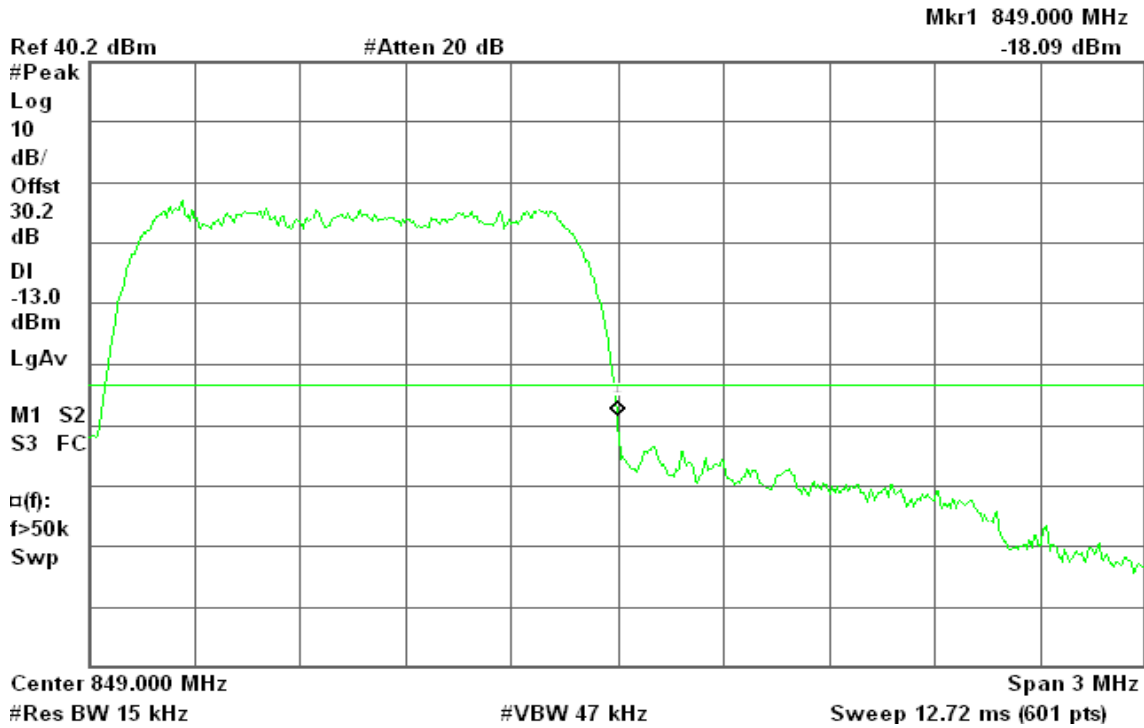
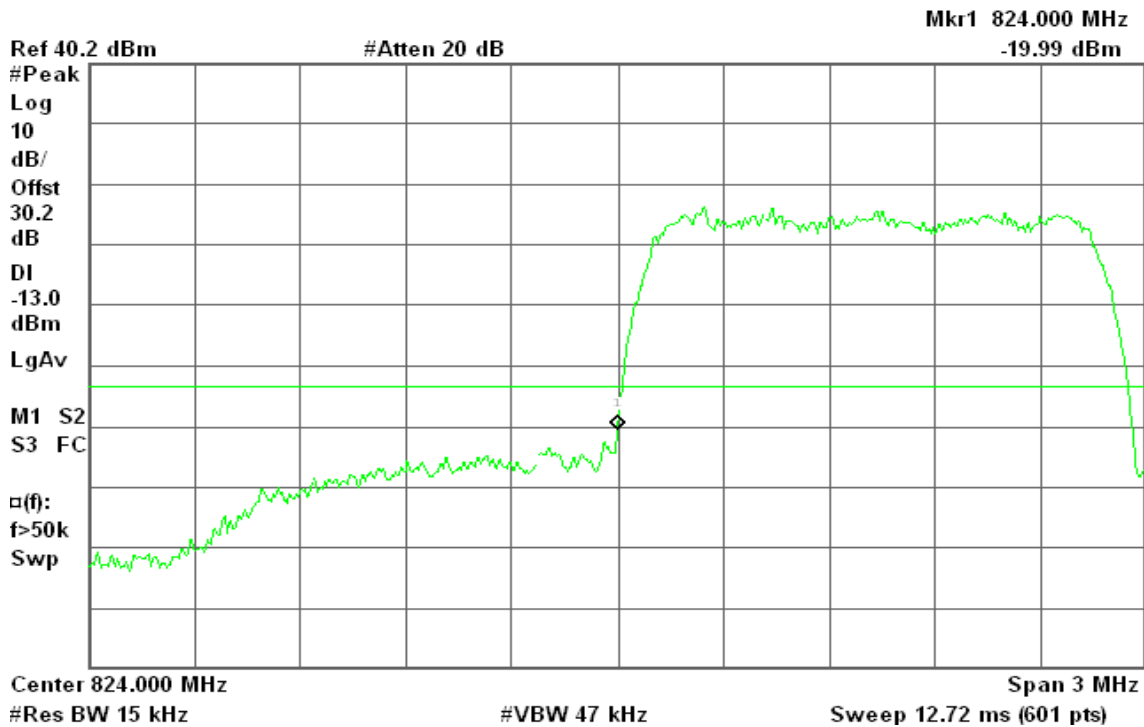

Figure 11-2: Band Edge emissions – CDMA2000 1xRTT / CH High

Agilent 20:13:29 Sep 17, 2009

R T





CDMA2000 1xEVDO Cellular

Figure 12-1: Band Edge emissions – CDMA2000 1xEVDO / CH Low

Agilent 21:23:11 Sep 17, 2009

R T

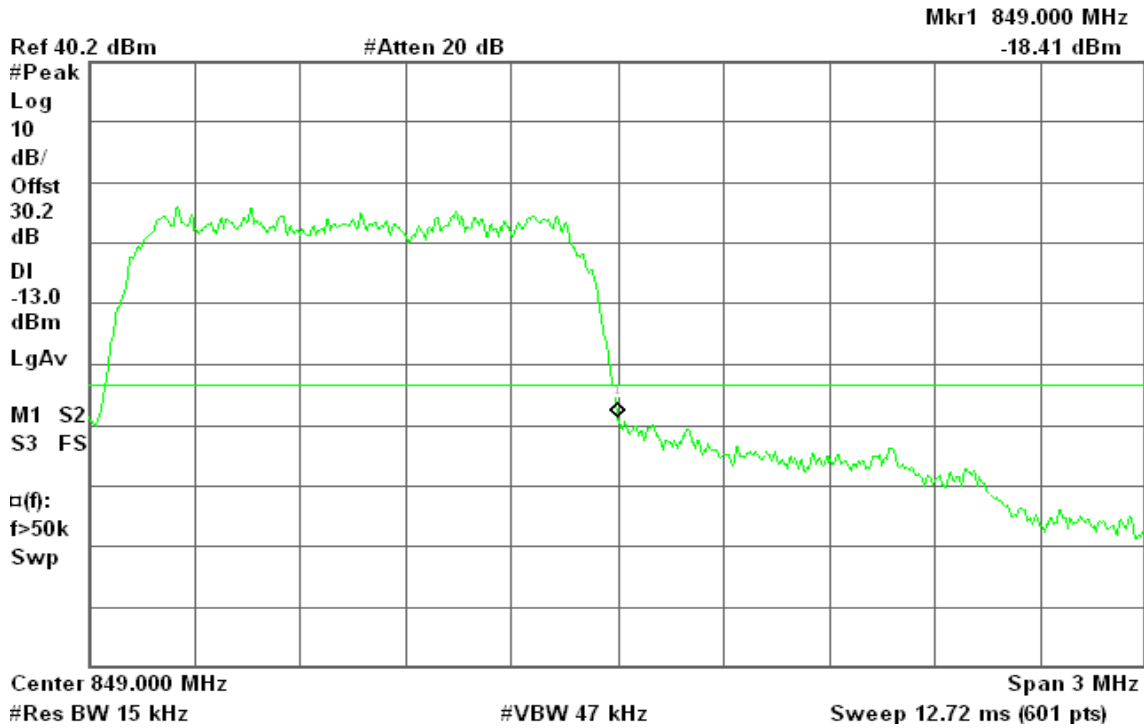
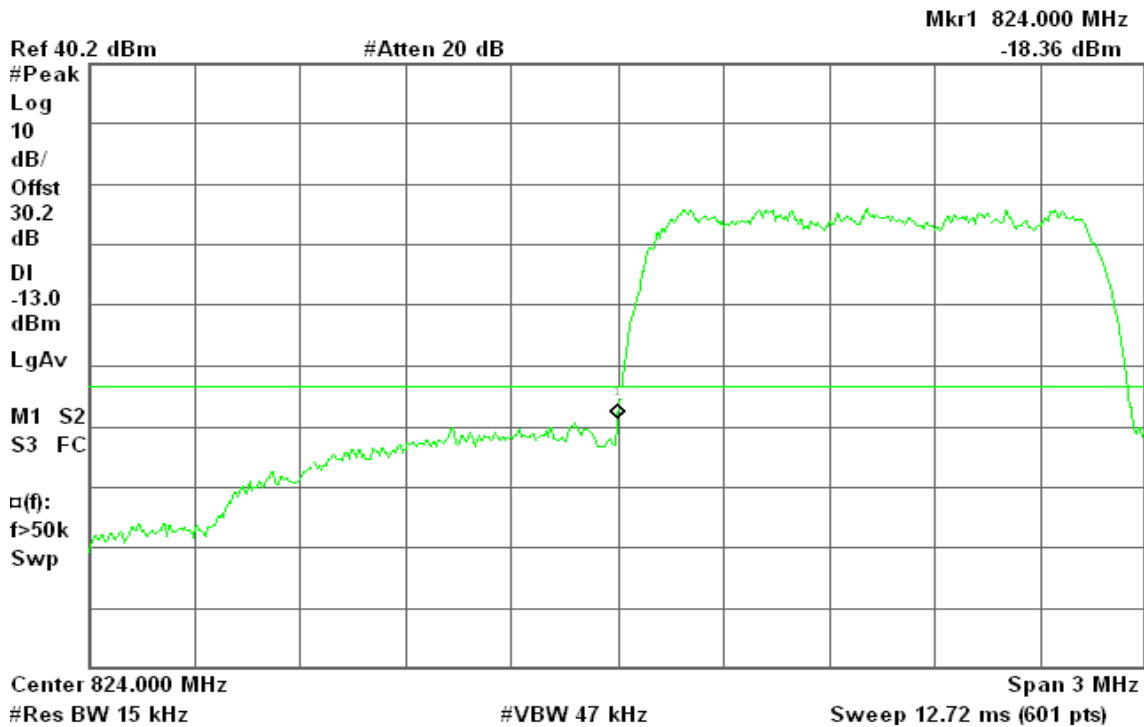

Figure 12-2: Band Edge emissions – CDMA2000 1xEVDO / CH High

Agilent 21:21:44 Sep 17, 2009

R T





CDMA2000 1xRTT PCS

Figure 13-1: Band Edge emissions – CDMA2000 1xRTT / CH Low

Agilent 20:47:14 Sep 17, 2009

R T

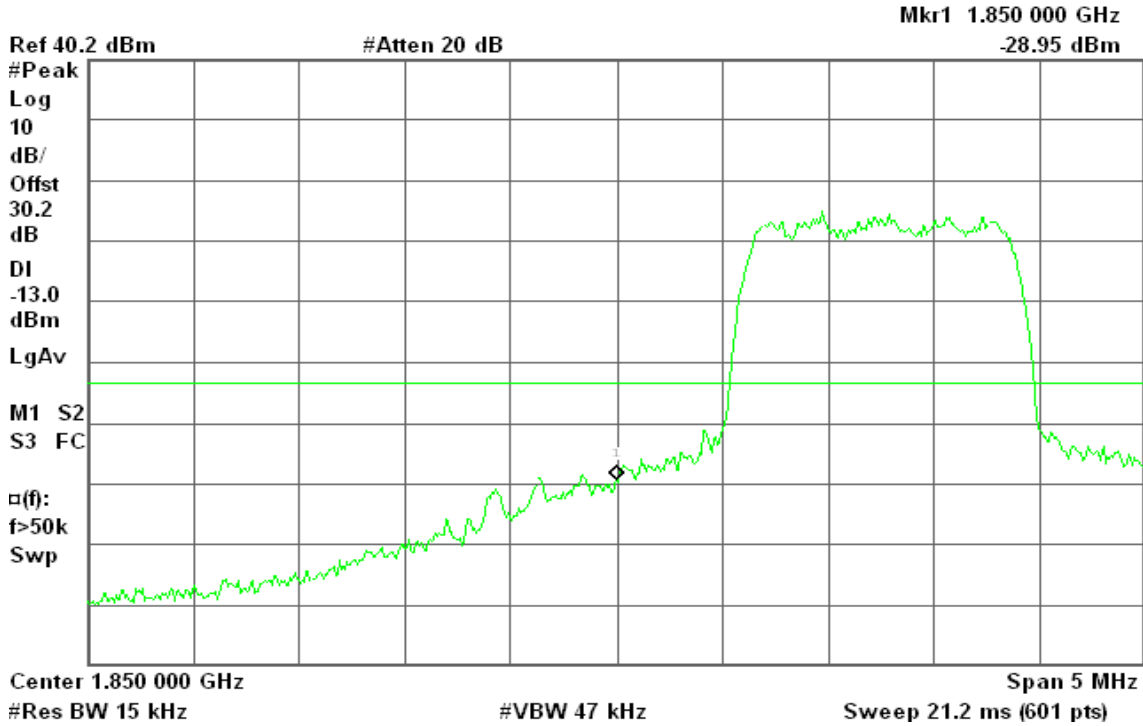
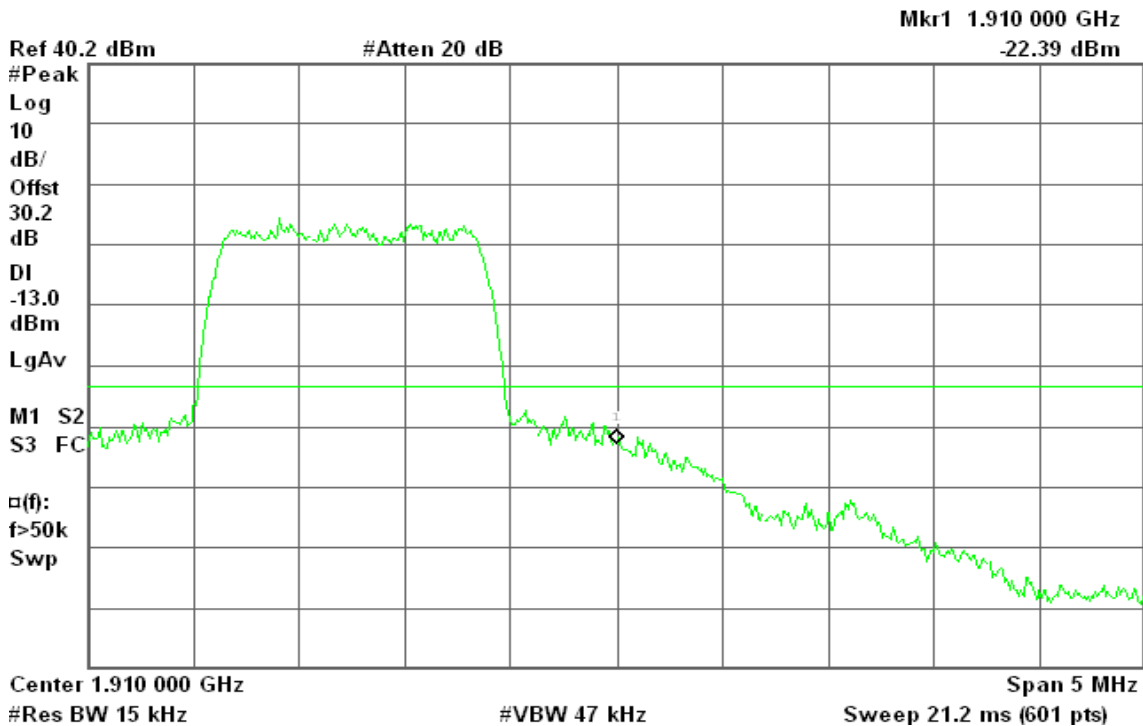

Figure 13-2: Band Edge emissions – CDMA2000 1xRTT / CH High

Agilent 20:47:50 Sep 17, 2009

R T





CDMA2000 1xEVDO PCS

Figure 14-1: Band Edge emissions – CDMA2000 1xEVDO / CH Low

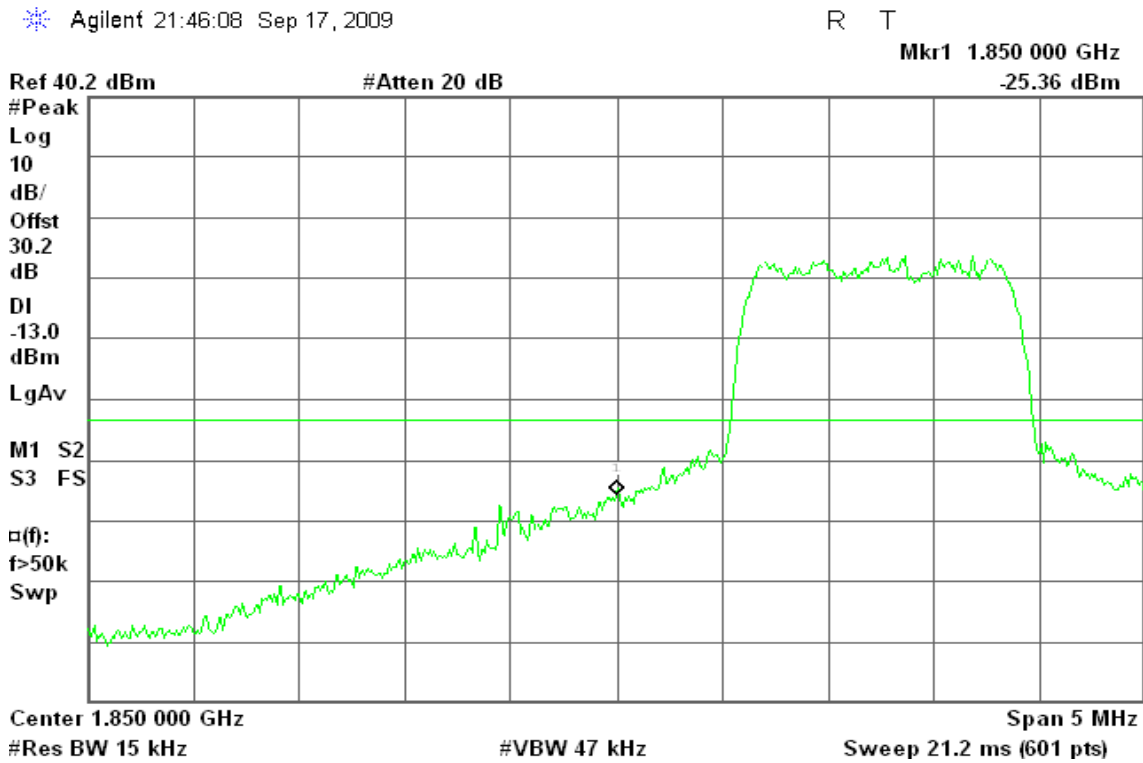
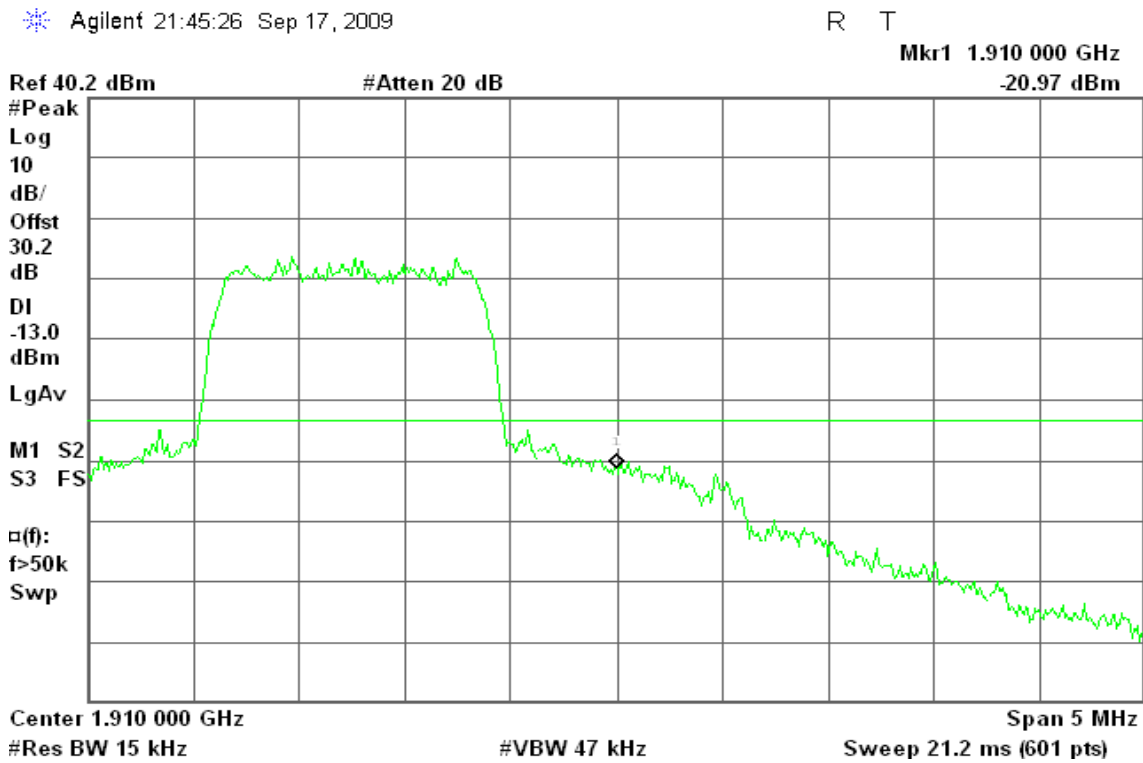

Figure 14-2: Band Edge emissions – CDMA2000 1xEVDO / CH High



7.5 FIELD STRENGTH OF SPURIOUS RADIATION MEASUREMENT

LIMIT

According to FCC §2.1053

Test Configuration

Below 1 GHz

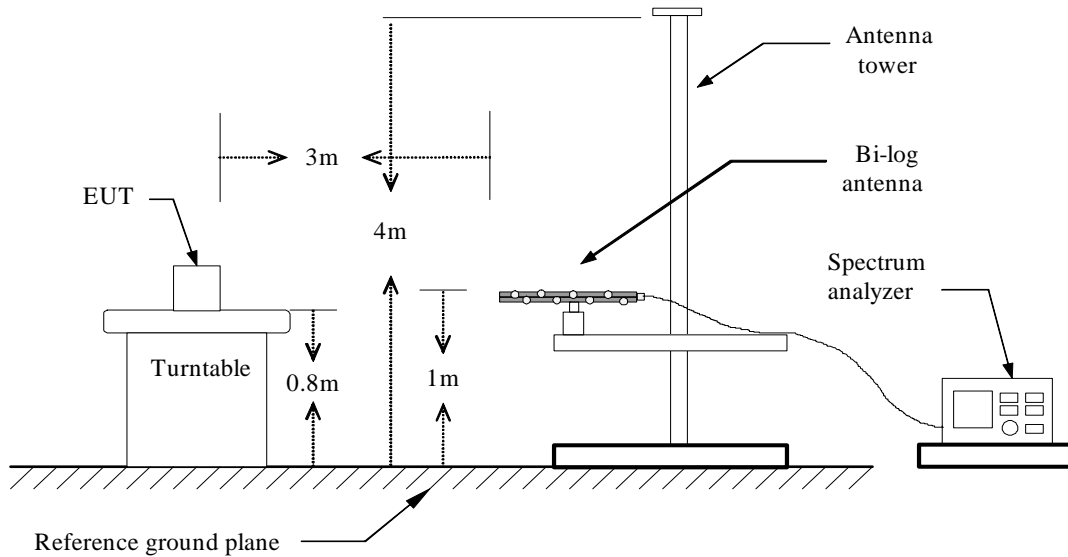

Above 1 GHz

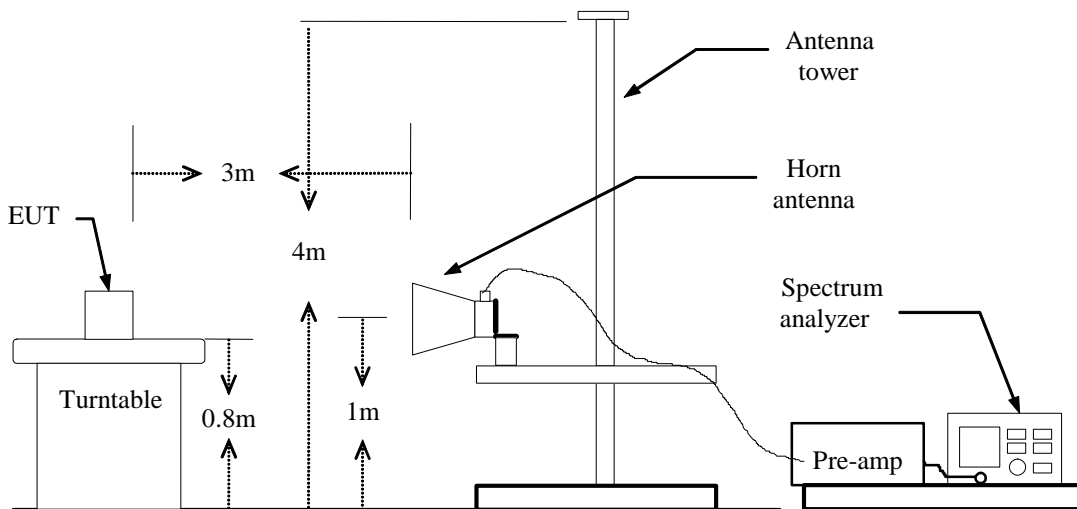

Substituted Method Test Set-up

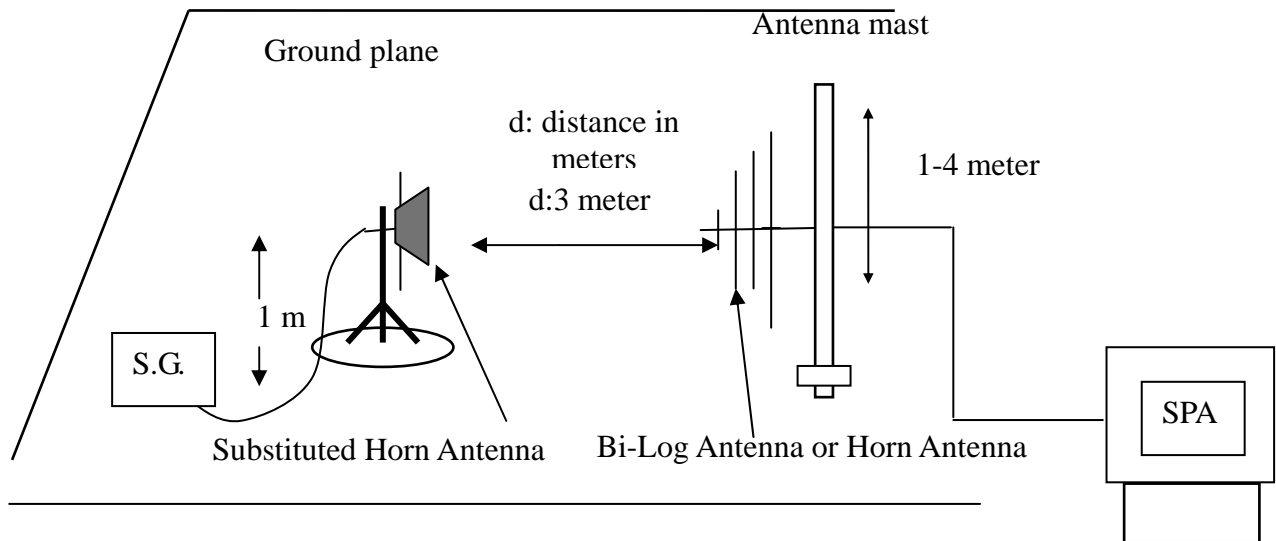

TEST PROCEDURE

The EUT was placed on a non-conductive, the measurement antenna was placed at a distance of 3 meters from the EUT. During the tests, the antenna height and the EUT azimuth were varied in order to identify the maximum level of emissions from the EUT. This maximization process was repeated with the EUT positioned in each of its three orthogonal orientations.

The frequency range up to tenth harmonic was investigated for each of three fundamental frequency (low, middle and high channels). Once spurious emission were identified, the power of the emission was determined using the substitution method.

The spurious emissions attenuation was calculated as the difference between radiated power at the fundamental frequency and the spurious emissions frequency.

$$ERP = \text{S.G. output (dBm)} + \text{Antenna Gain (dBd)} - \text{Cable (dB)}$$

$$EIRP = \text{S.G. output (dBm)} + \text{Antenna Gain (dBi)} - \text{Cable (dB)}$$

TEST RESULTS

Refer to the attached tabular data sheets.



Radiated Spurious Emission Measurement Result

Below 1GHz

Operation Mode: CDMA2000 / 850 / TX / CH 384

Test Date: September 15, 2009

Temperature: 25°C

Tested by: Jerry Lin

Humidity: 50 % RH

Polarity: Ver. / Hor.

Frequency (MHz)	Antenna Polarization (V/H)	Reading (dBm)	Correction Factor (dB)	Emission level (dBm)	Limit (dBm)	Margin (dB)
35.82	V	-38.82	-14.35	-53.17	-13.00	-40.17
57.16	V	-42.75	-15.54	-58.28	-13.00	-45.28
150.28	V	-58.93	-12.28	-71.21	-13.00	-58.21
194.90	V	-60.42	-13.97	-74.39	-13.00	-61.39
221.09	V	-61.31	-15.19	-76.50	-13.00	-63.50
290.93	V	-68.59	-11.91	-80.50	-13.00	-67.50
44.55	H	-52.53	-10.88	-63.42	-13.00	-50.42
99.84	H	-54.07	-17.49	-71.56	-13.00	-58.56
129.91	H	-52.26	-13.63	-65.89	-13.00	-52.89
252.13	H	-57.13	-14.60	-71.73	-13.00	-58.73
453.89	H	-62.91	-9.60	-72.52	-13.00	-59.52
672.14	H	-69.19	-6.27	-75.46	-13.00	-62.46

Remark:

1. *Measuring frequencies from 1 GHz to the 10th harmonic of highest fundamental frequency.*
2. *Measurements above show only up to 6 maximum emissions noted, or would be lesser, with " N/A " remark, if no specific emissions from the EUT are recorded (ie: margin>20dB from the applicable limit) and considered that's already beyond the background noise floor.*



Operation Mode: CDMA2000 / 850 / TX / CH 777

Test Date: September 15, 2009

Temperature: 25°C

Tested by: Jerry Lin

Humidity: 50 % RH

Polarity: Ver. / Hor.

Frequency (MHz)	Antenna Polarization (V/H)	Reading (dBm)	Correction Factor (dB)	Emission level (dBm)	Limit (dBm)	Margin (dB)
35.82	V	-38.17	-14.35	-52.52	-13.00	-39.52
56.19	V	-44.26	-15.61	-59.86	-13.00	-46.86
97.90	V	-52.95	-18.19	-71.14	-13.00	-58.14
150.28	V	-58.97	-12.28	-71.26	-13.00	-58.26
190.05	V	-59.12	-14.44	-73.55	-13.00	-60.55
225.94	V	-62.89	-14.80	-77.69	-13.00	-64.69
45.52	H	-51.69	-11.23	-62.92	-13.00	-49.92
100.81	H	-51.57	-17.28	-68.86	-13.00	-55.86
132.82	H	-58.38	-13.74	-72.12	-13.00	-59.12
149.31	H	-60.43	-13.14	-73.57	-13.00	-60.57
220.12	H	-58.80	-14.10	-72.90	-13.00	-59.90
287.05	H	-67.13	-12.86	-79.99	-13.00	-66.99

Remark:

1. Measuring frequencies from 1 GHz to the 10th harmonic of highest fundamental frequency.
2. Measurements above show only up to 6 maximum emissions noted, or would be lesser, with " N/A " remark, if no specific emissions from the EUT are recorded (ie: margin > 20dB from the applicable limit) and considered that's already beyond the background noise floor.



Operation Mode: CDMA2000 / 850 / TX / CH 1013

Test Date: September 15, 2009

Temperature: 25°C

Tested by: Jerry Lin

Humidity: 50 % RH

Polarity: Ver. / Hor.

Frequency (MHz)	Antenna Polarization (V/H)	Reading (dBm)	Correction Factor (dB)	Emission level (dBm)	Limit (dBm)	Margin (dB)
37.76	V	-40.87	-13.41	-54.29	-13.00	-41.29
56.19	V	-45.19	-15.61	-60.80	-13.00	-47.80
150.28	V	-59.28	-12.28	-71.56	-13.00	-58.56
196.84	V	-61.40	-13.78	-75.18	-13.00	-62.18
224.97	V	-62.84	-14.88	-77.72	-13.00	-64.72
512.09	V	-67.64	-8.19	-75.83	-13.00	-62.83
45.52	H	-54.52	-11.23	-65.75	-13.00	-52.75
99.84	H	-50.91	-17.49	-68.40	-13.00	-55.40
222.06	H	-58.93	-14.14	-73.07	-13.00	-60.07
408.30	H	-61.42	-10.59	-72.00	-13.00	-59.00
512.09	H	-65.83	-8.20	-74.03	-13.00	-61.03
683.78	H	-69.16	-6.13	-75.29	-13.00	-62.29

Remark:

1. Measuring frequencies from 1 GHz to the 10th harmonic of highest fundamental frequency.
2. Measurements above show only up to 6 maximum emissions noted, or would be lesser, with " N/A " remark, if no specific emissions from the EUT are recorded (ie: margin>20dB from the applicable limit) and considered that's already beyond the background noise floor.



Operation Mode: CDMA2000 / 1900 / TX / CH 25

Test Date: September 15, 2009

Temperature: 25°C

Tested by: Jerry Lin

Humidity: 50 % RH

Polarity: Ver. / Hor.

Frequency (MHz)	Antenna Polarization (V/H)	Reading (dBm)	Correction Factor (dB)	Emission level (dBm)	Limit (dBm)	Margin (dB)
34.85	V	-38.33	-14.84	-53.16	-13.00	-40.16
58.13	V	-43.46	-15.46	-58.93	-13.00	-45.93
98.87	V	-52.70	-17.93	-70.63	-13.00	-57.63
149.31	V	-58.78	-12.30	-71.08	-13.00	-58.08
191.99	V	-60.18	-14.25	-74.43	-13.00	-61.43
222.06	V	-63.00	-15.11	-78.12	-13.00	-65.12
45.52	H	-51.37	-11.23	-62.61	-13.00	-49.61
98.87	H	-50.07	-17.77	-67.84	-13.00	-54.84
133.79	H	-58.34	-13.78	-72.11	-13.00	-59.11
151.25	H	-58.98	-13.22	-72.20	-13.00	-59.20
187.14	H	-59.37	-13.95	-73.32	-13.00	-60.32
224.00	H	-58.03	-14.18	-72.21	-13.00	-59.21

Remark:

1. *Measuring frequencies from 1 GHz to the 10th harmonic of highest fundamental frequency.*
2. *Measurements above show only up to 6 maximum emissions noted, or would be lesser, with " N/A " remark, if no specific emissions from the EUT are recorded (ie: margin > 20dB from the applicable limit) and considered that's already beyond the background noise floor.*



Operation Mode: CDMA2000 / 1900 / TX / CH 600

Test Date: September 15, 2009

Temperature: 25°C

Tested by: Jerry Lin

Humidity: 50 % RH

Polarity: Ver. / Hor.

Frequency (MHz)	Antenna Polarization (V/H)	Reading (dBm)	Correction Factor (dB)	Emission level (dBm)	Limit (dBm)	Margin (dB)
37.76	V	-39.92	-13.41	-53.34	-13.00	-40.34
56.19	V	-43.06	-15.61	-58.67	-13.00	-45.67
132.82	V	-57.07	-12.50	-69.57	-13.00	-56.57
149.31	V	-58.41	-12.30	-70.71	-13.00	-57.71
193.93	V	-59.71	-14.06	-73.77	-13.00	-60.77
222.06	V	-61.86	-15.11	-76.97	-13.00	-63.97
45.52	H	-51.38	-11.23	-62.61	-13.00	-49.61
100.81	H	-50.74	-17.28	-68.02	-13.00	-55.02
132.82	H	-57.94	-13.74	-71.68	-13.00	-58.68
151.25	H	-59.16	-13.22	-72.38	-13.00	-59.38
187.14	H	-59.57	-13.95	-73.53	-13.00	-60.53
218.18	H	-58.00	-14.06	-72.06	-13.00	-59.06

Remark:

1. *Measuring frequencies from 1 GHz to the 10th harmonic of highest fundamental frequency.*
2. *Measurements above show only up to 6 maximum emissions noted, or would be lesser, with " N/A " remark, if no specific emissions from the EUT are recorded (ie: margin > 20dB from the applicable limit) and considered that's already beyond the background noise floor.*

**Operation Mode:** CDMA2000 / 1900 / TX / CH 1175**Test Date:** September 15, 2009**Temperature:** 25°C**Tested by:** Jerry Lin**Humidity:** 50 % RH**Polarity:** Ver. / Hor.

Frequency (MHz)	Antenna Polarization (V/H)	Reading (dBm)	Correction Factor (dB)	Emission level (dBm)	Limit (dBm)	Margin (dB)
34.85	V	-38.15	-14.84	-52.99	-13.00	-39.99
56.19	V	-43.90	-15.61	-59.51	-13.00	-46.51
100.81	V	-51.36	-17.46	-68.82	-13.00	-55.82
132.82	V	-58.08	-12.50	-70.58	-13.00	-57.58
187.14	V	-60.72	-14.41	-75.14	-13.00	-62.14
288.02	V	-67.30	-11.80	-79.10	-13.00	-66.10
45.52	H	-51.20	-11.23	-62.43	-13.00	-49.43
99.84	H	-50.98	-17.49	-68.47	-13.00	-55.47
132.82	H	-58.72	-13.74	-72.46	-13.00	-59.46
148.34	H	-59.17	-13.24	-72.40	-13.00	-59.40
186.17	H	-59.07	-13.97	-73.05	-13.00	-60.05
224.97	H	-57.92	-14.19	-72.11	-13.00	-59.11

Remark:

1. *Measuring frequencies from 1 GHz to the 10th harmonic of highest fundamental frequency.*
2. *Measurements above show only up to 6 maximum emissions noted, or would be lesser, with " N/A " remark, if no specific emissions from the EUT are recorded (ie: margin > 20dB from the applicable limit) and considered that's already beyond the background noise floor.*



Operation Mode: EVDO / 850 / TX / CH 384

Test Date: September 15, 2009

Temperature: 25°C

Tested by: Jerry Lin

Humidity: 50 % RH

Polarity: Ver. / Hor.

Frequency (MHz)	Antenna Polarization (V/H)	Reading (dBm)	Correction Factor (dB)	Emission level (dBm)	Limit (dBm)	Margin (dB)
34.85	V	-39.71	-14.84	-54.55	-13.00	-41.55
57.16	V	-43.75	-15.54	-59.29	-13.00	-46.29
98.87	V	-50.03	-17.93	-67.97	-13.00	-54.97
132.82	V	-59.35	-12.50	-71.86	-13.00	-58.86
187.14	V	-61.16	-14.41	-75.57	-13.00	-62.57
289.96	V	-67.91	-11.74	-79.65	-13.00	-66.65
44.55	H	-54.30	-10.88	-65.18	-13.00	-52.18
99.84	H	-51.14	-17.49	-68.63	-13.00	-55.63
131.85	H	-51.90	-13.70	-65.60	-13.00	-52.60
224.00	H	-59.46	-14.18	-73.64	-13.00	-60.64
303.54	H	-67.41	-13.93	-81.34	-13.00	-68.34
451.95	H	-62.84	-9.68	-72.52	-13.00	-59.52

Remark:

1. *Measuring frequencies from 1 GHz to the 10th harmonic of highest fundamental frequency.*
2. *Measurements above show only up to 6 maximum emissions noted, or would be lesser, with " N/A " remark, if no specific emissions from the EUT are recorded (ie: margin > 20dB from the applicable limit) and considered that's already beyond the background noise floor.*



Operation Mode: EVDO / 850 / TX / CH 777

Test Date: September 15, 2009

Temperature: 25°C

Tested by: Jerry Lin

Humidity: 50 % RH

Polarity: Ver. / Hor.

Frequency (MHz)	Antenna Polarization (V/H)	Reading (dBm)	Correction Factor (dB)	Emission level (dBm)	Limit (dBm)	Margin (dB)
35.82	V	-39.52	-14.35	-53.88	-13.00	-40.88
56.19	V	-44.41	-15.61	-60.02	-13.00	-47.02
99.84	V	-49.97	-17.68	-67.65	-13.00	-54.65
132.82	V	-59.51	-12.50	-72.01	-13.00	-59.01
191.02	V	-60.51	-14.34	-74.86	-13.00	-61.86
297.72	V	-66.98	-13.15	-80.14	-13.00	-67.14
45.52	H	-51.12	-11.23	-62.35	-13.00	-49.35
99.84	H	-51.36	-17.49	-68.84	-13.00	-55.84
133.79	H	-58.90	-13.78	-72.68	-13.00	-59.68
149.31	H	-59.81	-13.14	-72.95	-13.00	-59.95
223.03	H	-57.44	-14.16	-71.60	-13.00	-58.60
476.20	H	-68.80	-8.71	-77.51	-13.00	-64.51

Remark:

1. Measuring frequencies from 1 GHz to the 10th harmonic of highest fundamental frequency.
2. Measurements above show only up to 6 maximum emissions noted, or would be lesser, with " N/A " remark, if no specific emissions from the EUT are recorded (ie: margin > 20dB from the applicable limit) and considered that's already beyond the background noise floor.



Operation Mode: EVDO / 850 / TX / CH 1013

Test Date: September 15, 2009

Temperature: 25°C

Tested by: Jerry Lin

Humidity: 50 % RH

Polarity: Ver. / Hor.

Frequency (MHz)	Antenna Polarization (V/H)	Reading (dBm)	Correction Factor (dB)	Emission level (dBm)	Limit (dBm)	Margin (dB)
36.79	V	-39.95	-13.88	-53.83	-13.00	-40.83
56.19	V	-44.04	-15.61	-59.65	-13.00	-46.65
99.84	V	-50.40	-17.68	-68.08	-13.00	-55.08
132.82	V	-58.72	-12.50	-71.22	-13.00	-58.22
190.05	V	-61.19	-14.44	-75.62	-13.00	-62.62
512.09	V	-67.85	-8.19	-76.04	-13.00	-63.04
45.52	H	-54.35	-11.23	-65.58	-13.00	-52.58
100.81	H	-49.74	-17.28	-67.03	-13.00	-54.03
135.73	H	-58.92	-13.85	-72.77	-13.00	-59.77
224.97	H	-59.87	-14.19	-74.07	-13.00	-61.07
411.21	H	-60.83	-10.46	-71.29	-13.00	-58.29
512.09	H	-66.75	-8.20	-74.95	-13.00	-61.95

Remark:

1. Measuring frequencies from 1 GHz to the 10th harmonic of highest fundamental frequency.
2. Measurements above show only up to 6 maximum emissions noted, or would be lesser, with " N/A " remark, if no specific emissions from the EUT are recorded (ie: margin > 20dB from the applicable limit) and considered that's already beyond the background noise floor.



Operation Mode: EVDO / 1900 / TX / CH 25

Test Date: September 16, 2009

Temperature: 25°C

Tested by: Jerry Lin

Humidity: 50 % RH

Polarity: Ver. / Hor.

Frequency (MHz)	Antenna Polarization (V/H)	Reading (dBm)	Correction Factor (dB)	Emission level (dBm)	Limit (dBm)	Margin (dB)
36.79	V	-39.61	-13.88	-53.50	-13.00	-40.50
57.16	V	-41.85	-15.54	-57.39	-13.00	-44.39
99.84	V	-52.42	-17.68	-70.10	-13.00	-57.10
132.82	V	-58.20	-12.50	-70.70	-13.00	-57.70
191.99	V	-59.46	-14.25	-73.70	-13.00	-60.70
420.91	V	-66.79	-10.35	-77.14	-13.00	-64.14
45.52	H	-51.05	-11.23	-62.28	-13.00	-49.28
100.81	H	-51.03	-17.28	-68.31	-13.00	-55.31
134.76	H	-56.81	-13.82	-70.63	-13.00	-57.63
187.14	H	-57.70	-13.95	-71.65	-13.00	-58.65
222.06	H	-58.12	-14.14	-72.26	-13.00	-59.26
684.75	H	-67.94	-6.13	-74.07	-13.00	-61.07

Remark:

1. Measuring frequencies from 1 GHz to the 10th harmonic of highest fundamental frequency.
2. Measurements above show only up to 6 maximum emissions noted, or would be lesser, with " N/A " remark, if no specific emissions from the EUT are recorded (ie: margin > 20dB from the applicable limit) and considered that's already beyond the background noise floor.



Operation Mode: EVDO / 1900 / TX / CH 600

Test Date: September 16, 2009

Temperature: 25°C

Tested by: Jerry Lin

Humidity: 50 % RH

Polarity: Ver. / Hor.

Frequency (MHz)	Antenna Polarization (V/H)	Reading (dBm)	Correction Factor (dB)	Emission level (dBm)	Limit (dBm)	Margin (dB)
36.79	V	-38.66	-13.88	-52.54	-13.00	-39.54
55.22	V	-41.65	-15.68	-57.34	-13.00	-44.34
98.87	V	-51.99	-17.93	-69.93	-13.00	-56.93
150.28	V	-59.29	-12.28	-71.57	-13.00	-58.57
193.93	V	-60.05	-14.06	-74.11	-13.00	-61.11
286.08	V	-66.93	-11.86	-78.79	-13.00	-65.79
318.09	V	-67.06	-13.49	-80.55	-13.00	-67.55
45.52	H	-51.48	-11.23	-62.71	-13.00	-49.71
99.84	H	-50.31	-17.49	-67.80	-13.00	-54.80
132.82	H	-57.54	-13.74	-71.28	-13.00	-58.28
192.96	H	-58.54	-13.48	-72.02	-13.00	-59.02
427.70	H	-68.17	-10.11	-78.28	-13.00	-65.28
637.22	H	-68.83	-6.38	-75.21	-13.00	-62.21

Remark:

1. Measuring frequencies from 1 GHz to the 10th harmonic of highest fundamental frequency.
2. Measurements above show only up to 6 maximum emissions noted, or would be lesser, with " N/A " remark, if no specific emissions from the EUT are recorded (ie: margin > 20dB from the applicable limit) and considered that's already beyond the background noise floor.



Operation Mode: EVDO / 1900 / TX / CH 1175

Test Date: September 16, 2009

Temperature: 25°C

Tested by: Jerry Lin

Humidity: 50 % RH

Polarity: Ver. / Hor.

Frequency (MHz)	Antenna Polarization (V/H)	Reading (dBm)	Correction Factor (dB)	Emission level (dBm)	Limit (dBm)	Margin (dB)
35.82	V	-38.12	-14.35	-52.48	-13.00	-39.48
58.13	V	-42.57	-15.46	-58.03	-13.00	-45.03
150.28	V	-59.34	-12.28	-71.63	-13.00	-58.63
191.99	V	-59.33	-14.25	-73.58	-13.00	-60.58
288.02	V	-67.27	-11.80	-79.07	-13.00	-66.07
447.10	V	-67.67	-9.89	-77.57	-13.00	-64.57
45.52	H	-51.43	-11.23	-62.66	-13.00	-49.66
99.84	H	-50.52	-17.49	-68.01	-13.00	-55.01
135.73	H	-56.27	-13.85	-70.12	-13.00	-57.12
219.15	H	-58.46	-14.08	-72.54	-13.00	-59.54
284.14	H	-66.74	-12.84	-79.58	-13.00	-66.58
557.68	H	-68.81	-7.70	-76.51	-13.00	-63.51

Remark:

1. Measuring frequencies from 1 GHz to the 10th harmonic of highest fundamental frequency.
2. Measurements above show only up to 6 maximum emissions noted, or would be lesser, with " N/A " remark, if no specific emissions from the EUT are recorded (ie: margin > 20dB from the applicable limit) and considered that's already beyond the background noise floor.



Above 1GHz

Operation Mode: CDMA2000 / 850 / TX / CH 384

Test Date: September 15, 2009

Temperature: 25°C

Tested by: Jerry Lin

Humidity: 50 % RH

Polarity: Ver. / Hor.

Frequency (MHz)	Antenna Polarization (V/H)	Reading (dBm)	Correction Factor (dB)	Emission level (dBm)	Limit (dBm)	Margin (dB)
2512.00	V	-57.04	3.66	-53.38	-13.00	-40.38
5018.00	V	-62.30	9.69	-52.62	-13.00	-39.62
N/A						
1672.00	H	-57.64	0.84	-56.80	-13.00	-43.80
2512.00	H	-50.92	3.96	-46.96	-13.00	-33.96
N/A						

Remark:

1. *Measuring frequencies from 1 GHz to the 10th harmonic of highest fundamental frequency.*
2. *Measurements above show only up to 6 maximum emissions noted, or would be lesser, with “ N/A ” remark, if no specific emissions from the EUT are recorded (ie: margin>20dB from the applicable limit) and considered that's already beyond the background noise floor.*



Operation Mode: CDMA2000 / 850 / TX / CH 777

Test Date: September 15, 2009

Temperature: 25°C

Tested by: Jerry Lin

Humidity: 50 % RH

Polarity: Ver. / Hor.

Frequency (MHz)	Antenna Polarization (V/H)	Reading (dBm)	Correction Factor (dB)	Emission level (dBm)	Limit (dBm)	Margin (dB)
2547.00	V	-58.70	3.77	-54.93	-13.00	-41.93
N/A						
1700.00	H	-57.19	0.90	-56.29	-13.00	-43.29
2547.00	H	-51.21	4.06	-47.15	-13.00	-34.15
N/A						

Remark:

1. Measuring frequencies from 1 GHz to the 10th harmonic of highest fundamental frequency.
2. Measurements above show only up to 6 maximum emissions noted, or would be lesser, with " N/A " remark, if no specific emissions from the EUT are recorded (ie: margin > 20dB from the applicable limit) and considered that's already beyond the background noise floor.



Operation Mode: CDMA2000 / 850 / TX / CH 1013

Test Date: September 15, 2009

Temperature: 25°C

Tested by: Jerry Lin

Humidity: 50 % RH

Polarity: Ver. / Hor.

Frequency (MHz)	Antenna Polarization (V/H)	Reading (dBm)	Correction Factor (dB)	Emission level (dBm)	Limit (dBm)	Margin (dB)
1672.00	V	-62.35	0.73	-61.61	-13.00	-48.61
2477.00	V	-56.22	3.52	-52.70	-13.00	-39.70
N/A						
1651.00	H	-56.94	0.80	-56.14	-13.00	-43.14
2477.00	H	-51.19	3.81	-47.38	-13.00	-34.38
N/A						

Remark:

1. Measuring frequencies from 1 GHz to the 10th harmonic of highest fundamental frequency.
2. Measurements above show only up to 6 maximum emissions noted, or would be lesser, with " N/A " remark, if no specific emissions from the EUT are recorded (ie: margin > 20dB from the applicable limit) and considered that's already beyond the background noise floor.



Operation Mode: CDMA2000 / 1900 / TX / CH 25

Test Date: September 15, 2009

Temperature: 25°C

Tested by: Jerry Lin

Humidity: 50 % RH

Polarity: Ver. / Hor.

Frequency (MHz)	Antenna Polarization (V/H)	Reading (dBm)	Correction Factor (dB)	Emission level (dBm)	Limit (dBm)	Margin (dB)
3464.00	V	-61.83	5.79	-56.04	-13.00	-43.04
5557.00	V	-57.30	9.92	-47.37	-13.00	-34.37
N/A						
3702.00	H	-61.62	7.85	-53.77	-13.00	-40.77
5557.00	H	-52.95	10.26	-42.69	-13.00	-29.69
N/A						

Remark:

1. Measuring frequencies from 1 GHz to the 10th harmonic of highest fundamental frequency.
2. Measurements above show only up to 6 maximum emissions noted, or would be lesser, with " N/A " remark, if no specific emissions from the EUT are recorded (ie: margin > 20dB from the applicable limit) and considered that's already beyond the background noise floor.



Operation Mode: CDMA2000 / 1900 / TX / CH 600

Test Date: September 15, 2009

Temperature: 25°C

Tested by: Jerry Lin

Humidity: 50 % RH

Polarity: Ver. / Hor.

Frequency (MHz)	Antenna Polarization (V/H)	Reading (dBm)	Correction Factor (dB)	Emission level (dBm)	Limit (dBm)	Margin (dB)
3954.00	V	-62.75	7.24	-55.51	-13.00	-42.51
5641.00	V	-51.80	9.94	-41.86	-13.00	-28.86
N/A						
3758.00	H	-62.38	8.12	-54.25	-13.00	-41.25
5641.00	H	-53.66	10.28	-43.38	-13.00	-30.38
N/A						

Remark:

1. *Measuring frequencies from 1 GHz to the 10th harmonic of highest fundamental frequency.*
2. *Measurements above show only up to 6 maximum emissions noted, or would be lesser, with " N/A " remark, if no specific emissions from the EUT are recorded (ie: margin > 20dB from the applicable limit) and considered that's already beyond the background noise floor.*



Operation Mode: CDMA2000 / 1900 / TX / CH 1175

Test Date: September 15, 2009

Temperature: 25°C

Tested by: Jerry Lin

Humidity: 50 % RH

Polarity: Ver. / Hor.

Frequency (MHz)	Antenna Polarization (V/H)	Reading (dBm)	Correction Factor (dB)	Emission level (dBm)	Limit (dBm)	Margin (dB)
3821.00	V	-63.12	6.83	-56.29	-13.00	-43.29
5725.00	V	-56.58	9.96	-46.62	-13.00	-33.62
N/A						
3975.00	H	-63.06	9.21	-53.85	-13.00	-40.85
5725.00	H	-57.79	10.31	-47.49	-13.00	-34.49
N/A						

Remark:

1. Measuring frequencies from 1 GHz to the 10th harmonic of highest fundamental frequency.
2. Measurements above show only up to 6 maximum emissions noted, or would be lesser; with " N/A " remark, if no specific emissions from the EUT are recorded (ie: margin > 20dB from the applicable limit) and considered that's already beyond the background noise floor.



Operation Mode: EVDO / 850 / TX / CH 384

Test Date: September 15, 2009

Temperature: 25°C

Tested by: Jerry Lin

Humidity: 50 % RH

Polarity: Ver. / Hor.

Frequency (MHz)	Antenna Polarization (V/H)	Reading (dBm)	Correction Factor (dB)	Emission level (dBm)	Limit (dBm)	Margin (dB)
1742.00	V	-53.44	0.88	-52.56	-13.00	-39.56
2512.00	V	-50.17	3.66	-46.51	-13.00	-33.51
N/A						
1672.00	H	-56.82	0.84	-55.98	-13.00	-42.98
2512.00	H	-53.09	3.96	-49.13	-13.00	-36.13
N/A						

Remark:

1. Measuring frequencies from 1 GHz to the 10th harmonic of highest fundamental frequency.
2. Measurements above show only up to 6 maximum emissions noted, or would be lesser, with " N/A " remark, if no specific emissions from the EUT are recorded (ie: margin > 20dB from the applicable limit) and considered that's already beyond the background noise floor.



Operation Mode: EVDO / 850 / TX / CH 777

Test Date: September 15, 2009

Temperature: 25°C

Tested by: Jerry Lin

Humidity: 50 % RH

Polarity: Ver. / Hor.

Frequency (MHz)	Antenna Polarization (V/H)	Reading (dBm)	Correction Factor (dB)	Emission level (dBm)	Limit (dBm)	Margin (dB)
1700.00	V	-60.10	0.79	-59.31	-13.00	-46.31
2547.00	V	-54.42	3.77	-50.66	-13.00	-37.66
N/A						
1700.00	H	-56.23	0.90	-55.33	-13.00	-42.33
2547.00	H	-53.33	4.06	-49.26	-13.00	-36.26
N/A						

Remark:

1. Measuring frequencies from 1 GHz to the 10th harmonic of highest fundamental frequency.
2. Measurements above show only up to 6 maximum emissions noted, or would be lesser, with " N/A " remark, if no specific emissions from the EUT are recorded (ie: margin > 20dB from the applicable limit) and considered that's already beyond the background noise floor.



Operation Mode: EVDO / 850 / TX / CH 1013

Test Date: September 15, 2009

Temperature: 25°C

Tested by: Jerry Lin

Humidity: 50 % RH

Polarity: Ver. / Hor.

Frequency (MHz)	Antenna Polarization (V/H)	Reading (dBm)	Correction Factor (dB)	Emission level (dBm)	Limit (dBm)	Margin (dB)
1651.00	V	-60.11	0.69	-59.42	-13.00	-46.42
2477.00	V	-48.66	3.52	-45.14	-13.00	-32.14
N/A						
1651.00	H	-56.93	0.80	-56.13	-13.00	-43.13
2477.00	H	-49.18	3.81	-45.37	-13.00	-32.37
N/A						

Remark:

1. Measuring frequencies from 1 GHz to the 10th harmonic of highest fundamental frequency.
2. Measurements above show only up to 6 maximum emissions noted, or would be lesser, with " N/A " remark, if no specific emissions from the EUT are recorded (ie: margin > 20dB from the applicable limit) and considered that's already beyond the background noise floor.



Operation Mode: EVDO / 1900 / TX / CH 25

Test Date: September 15, 2009

Temperature: 25°C

Tested by: Jerry Lin

Humidity: 50 % RH

Polarity: Ver. / Hor.

Frequency (MHz)	Antenna Polarization (V/H)	Reading (dBm)	Correction Factor (dB)	Emission level (dBm)	Limit (dBm)	Margin (dB)
3954.00	V	-62.75	7.24	-55.52	-13.00	-42.52
5557.00	V	-59.27	9.92	-49.35	-13.00	-36.35
N/A						
5557.00	H	-60.26	10.26	-50.00	-13.00	-37.00
N/A						

Remark:

1. Measuring frequencies from 1 GHz to the 10th harmonic of highest fundamental frequency.
2. Measurements above show only up to 6 maximum emissions noted, or would be lesser, with " N/A " remark, if no specific emissions from the EUT are recorded (ie: margin > 20dB from the applicable limit) and considered that's already beyond the background noise floor.



Operation Mode: EVDO / 1900 / TX / CH 600

Test Date: September 15, 2009

Temperature: 25°C

Tested by: Jerry Lin

Humidity: 50 % RH

Polarity: Ver. / Hor.

Frequency (MHz)	Antenna Polarization (V/H)	Reading (dBm)	Correction Factor (dB)	Emission level (dBm)	Limit (dBm)	Margin (dB)
3625.00	V	-61.80	6.23	-55.57	-13.00	-42.57
5641.00	V	-57.49	9.94	-47.55	-13.00	-34.55
N/A						
5641.00	H	-58.87	10.28	-48.59	-13.00	-35.59
N/A						

Remark:

1. Measuring frequencies from 1 GHz to the 10th harmonic of highest fundamental frequency.
2. Measurements above show only up to 6 maximum emissions noted, or would be lesser, with " N/A " remark, if no specific emissions from the EUT are recorded (ie: margin > 20dB from the applicable limit) and considered that's already beyond the background noise floor.



Operation Mode: EVDO / 1900 / TX / CH 1175

Test Date: September 15, 2009

Temperature: 25°C

Tested by: Jerry Lin

Humidity: 50 % RH

Polarity: Ver. / Hor.

Frequency (MHz)	Antenna Polarization (V/H)	Reading (dBm)	Correction Factor (dB)	Emission level (dBm)	Limit (dBm)	Margin (dB)
5725.00	V	-58.89	9.96	-48.93	-13.00	-35.93
N/A						
4451.00	H	-61.93	9.54	-52.39	-13.00	-39.39
N/A						

Remark:

1. Measuring frequencies from 1 GHz to the 10th harmonic of highest fundamental frequency.
2. Measurements above show only up to 6 maximum emissions noted, or would be lesser, with " N/A " remark, if no specific emissions from the EUT are recorded (ie: margin > 20dB from the applicable limit) and considered that's already beyond the background noise floor.

7.6 FREQUENCY STABILITY V.S. TEMPERATURE MEASUREMENT

LIMIT

According to FCC §2.1055, FCC §24.235.

Frequency Tolerance: 2.5 ppm

Test Configuration

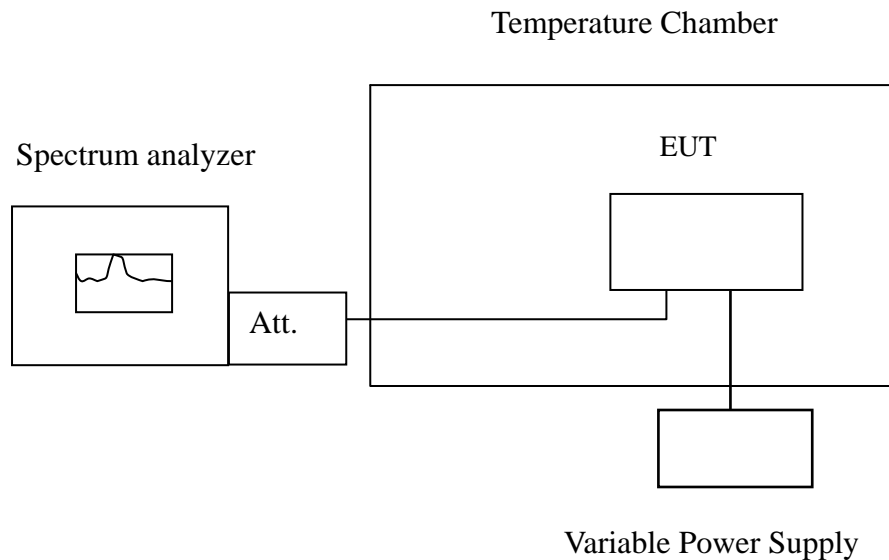

Remark: Measurement setup for testing on Antenna connector



TEST PROCEDURE

The equipment under test was connected to an external AC or DC power supply and input rated voltage. RF output was connected to a frequency counter or spectrum analyzer via feed through attenuators. The EUT was placed inside the temperature chamber. Set the spectrum analyzer RBW low enough to obtain the desired frequency resolution and measure EUT 20°C operating frequency as reference frequency. Turn EUT off and set the chamber temperature to -30°C. After the temperature stabilized for approximately 30 minutes recorded the frequency. Repeat step measure with 10°C increased per stage until the highest temperature of +50°C reached.

TEST RESULTS

No non-compliance noted.

Reference Frequency: CDMA2000 Mid Channel 836.52MHz @ 20°C				
Limit: +/- 2.5 ppm = 2091 Hz				
Power Supply Vdc	Environment Temperature (°C)	Frequency (Hz)	Delta (Hz)	Limit (Hz)
3.7	50	83599999	1	2090
	40	83599998	0	
	30	83600004	6	
	20	83599998	0	
	10	83600001	3	
	0	83599998	0	
	-10	83600003	5	
	-20	83600001	3	
	-30	83600003	5	

Reference Frequency: CDMA2000 Mid Channel 1880MHz @ 20°C				
Limit: +/- 2.5 ppm = 4700 Hz				
Power Supply Vdc	Environment Temperature (°C)	Frequency (Hz)	Delta (Hz)	Limit (Hz)
3.7	50	1880000005	7	4700
	40	1880000003	5	
	30	1880000002	4	
	20	1879999998	0	
	10	1880000002	4	
	0	1880000003	5	
	-10	1880000002	4	
	-20	1880000002	4	
	-30	1880000004	6	



Reference Frequency: EVDO Mid Channel 836.52MHz @ 20°C				
Limit: +/- 2.5 ppm = 2091 Hz				
Power Supply Vdc	Environment Temperature (°C)	Frequency (Hz)	Delta (Hz)	Limit (Hz)
3.7	50	83599997.3	-4	2090
	40	83599996.5	-5	
	30	83599999.7	-1	
	20	83600001	0	
	10	83599998.6	-2	
	0	83599999.9	-1	
	-10	83600001.3	0	
	-20	83600001.5	1	
	-30	83600000.1	-1	

Reference Frequency: EVDO Mid Channel 1880MHz @ 20°C				
Limit: +/- 2.5 ppm = 4700 Hz				
Power Supply Vdc	Environment Temperature (°C)	Frequency (Hz)	Delta (Hz)	Limit (Hz)
3.7	50	1879999999	0	4700
	40	1880000001	2	
	30	1880000002	3	
	20	1879999999	0	
	10	1880000001	2	
	0	1880000001	2	
	-10	1879999999	0	
	-20	1879999998	-1	
	-30	1880000004	5	

7.7 FREQUENCY STABILITY V.S. VOLTAGE MEASUREMENT

LIMIT

According to FCC §2.1055, FCC §24.235,

Frequency Tolerance: 2.5 ppm.

Test Configuration

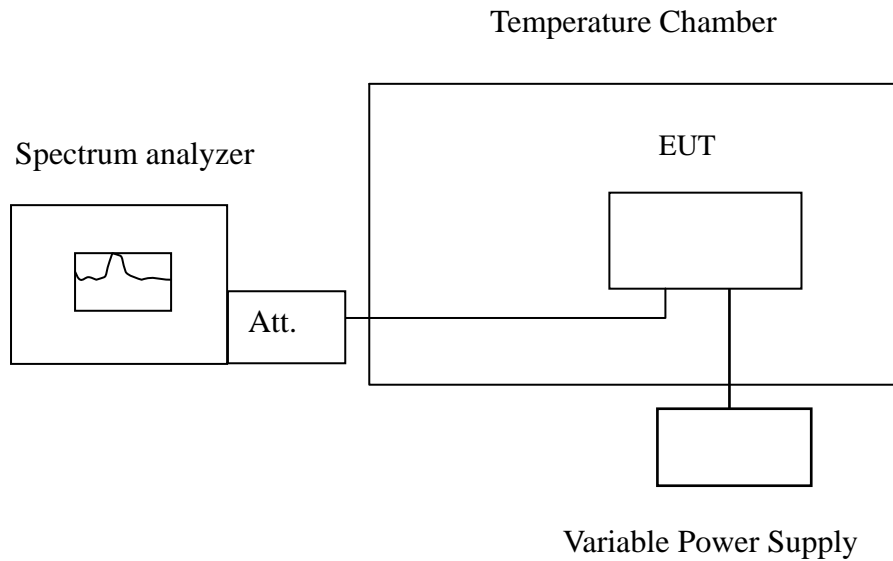

Remark: Measurement setup for testing on Antenna connector.



TEST PROCEDURE

Set chamber temperature to 20°C. Use a variable AC power supply / DC power source to power the EUT and set the voltage to rated voltage. Set the spectrum analyzer RBW low enough to obtain the desired frequency resolution and recorded the frequency.

Reduce the input voltage to specify extreme voltage variation (± 15%) and endpoint, record the maximum frequency change.

TEST RESULTS

No non-compliance noted.

Reference Frequency: CDMA2000 Mid Channel 836.52MHz @ 20°C				
Limit: +/- 2.5 ppm = 2091 Hz				
Power Supply Vdc	Environment Temperature (°C)	Frequency (Hz)	Delta (Hz)	Limit (Hz)
4.255	20	83599999	1	2090
3.7		83599998	0	
3.145		83599996	-2	
3.1END		83599998	2	

Reference Frequency: CDMA2000 Mid Channel 1880MHz @ 20°C				
Limit: ± 2.5 ppm = 4700 Hz				
Power Supply Vdc	Environment Temperature (°C)	Frequency (Hz)	Delta (Hz)	Limit (Hz)
4.255	20	1879999999	1	4700
3.7		1879999998	0	
3.145		1880000001	3	
3.1END		1879999997	-1	



Reference Frequency: EVDO Mid Channel 836.52MHz @ 20°C				
Limit: +/- 2.5 ppm = 2091 Hz				
Power Supply Vdc	Environment Temperature (°C)	Frequency (Hz)	Delta (Hz)	Limit (Hz)
4.255	20	83600001	0	2090
3.7		83600001	0	
3.145		83599998	-3	
3.1END		83599997	-1	

Reference Frequency: EVDO Mid Channel 1880MHz @ 20°C				
Limit: ± 2.5 ppm = 4700 Hz				
Power Supply Vdc	Environment Temperature (°C)	Frequency (Hz)	Delta (Hz)	Limit (Hz)
4.255	20	1879999997	-2	4700
3.7		1879999999	0	
3.145		1879999998	-1	
3.1END		1880000003	4	



7.8 POWERLINE CONDUCTED EMISSIONS

LIMIT

For an intentional radiator which is designed to be connected to the public utility (AC) power line, the radio frequency voltage that is conducted back onto the AC power line on any frequency or frequencies within the band 150 kHz to 30 MHz shall not exceed 250 microvolts (The limit decreases linearly with the logarithm of the frequency in the range 0.15 MHz to 0.50 MHz). The limits at specific frequency range is listed as follows:

Frequency Range (MHz)	Limits (dB μ V)	
	Quasi-peak	Average
0.15 to 0.50	66 to 56	56 to 46
0.50 to 5	56	46
5 to 30	60	50

Compliance with this provision shall be based on the measurement of the radio frequency voltage between each power line (LINE and NEUTRAL) and ground at the power terminals.

Test Configuration

See test photographs attached in Appendix 1 for the actual connections between EUT and support equipment.

TEST PROCEDURE

1. The EUT was placed on a table, which is 0.8m above ground plane.
2. Maximum procedure was performed on the six highest emissions to ensure EUT compliance.
3. Repeat above procedures until all frequency measured were complete.

**TEST RESULTS**

The initial step in collecting conducted data is a spectrum analyzer peak scan of the measurement range. Significant peaks are then marked as shown on the following data page, and these signals are then quasi-peaked.

Operation Mode: Normal Link **Test Date:** September 30, 2009
Temperature: 22°C **Tested by:** Mark Yang
Humidity: 45% RH

Freq. (MHz)	QP Reading	AV Reading	Corr. factor	QP Result	AV Result	QP Limit	AV Limit	QP Margin	AV Margin	Note
0.1750	45.79	17.29	0.11	45.90	17.40	64.72	54.72	-18.82	-37.32	L1
0.1950	47.01	39.01	0.09	47.10	39.10	63.82	53.82	-16.72	-14.72	L1
0.2600	38.22	30.12	0.08	38.30	30.20	61.43	51.43	-23.13	-21.23	L1
2.7200	38.34	32.14	0.06	38.40	32.20	56.00	46.00	-17.60	-13.80	L1
3.5850	43.24	33.74	0.06	43.30	33.80	56.00	46.00	-12.70	-12.20	L1
3.9150	42.64	33.04	0.06	42.70	33.10	56.00	46.00	-13.30	-12.90	L1
0.1550	49.18	20.78	0.12	49.30	20.90	65.73	55.73	-16.43	-34.83	L2
0.1950	48.61	39.41	0.09	48.70	39.50	63.82	53.82	-15.12	-14.32	L2
0.3328	35.62	29.52	0.08	35.70	29.60	59.38	49.38	-23.68	-19.78	L2
2.7826	35.44	26.14	0.06	35.50	26.20	56.00	46.00	-20.50	-19.80	L2
3.1801	39.34	26.54	0.06	39.40	26.60	56.00	46.00	-16.60	-19.40	L2
3.5772	38.94	26.34	0.06	39.00	26.40	56.00	46.00	-17.00	-19.60	L2

Remark:

1. Measuring frequencies from 0.15 MHz to 30MHz.
2. The emissions measured in frequency range from 0.15 MHz to 30MHz were made with an instrument using Quasi-peak detector and average detector.
3. The IF bandwidth of SPA between 0.15MHz to 30MHz was 10kHz; the IF bandwidth of Test Receiver between 0.15MHz to 30MHz was 9kHz;
4. L1 = Line One (Live Line) / L2 = Line Two (Neutral Line)



Test Plots

Conducted emissions (Line 1)

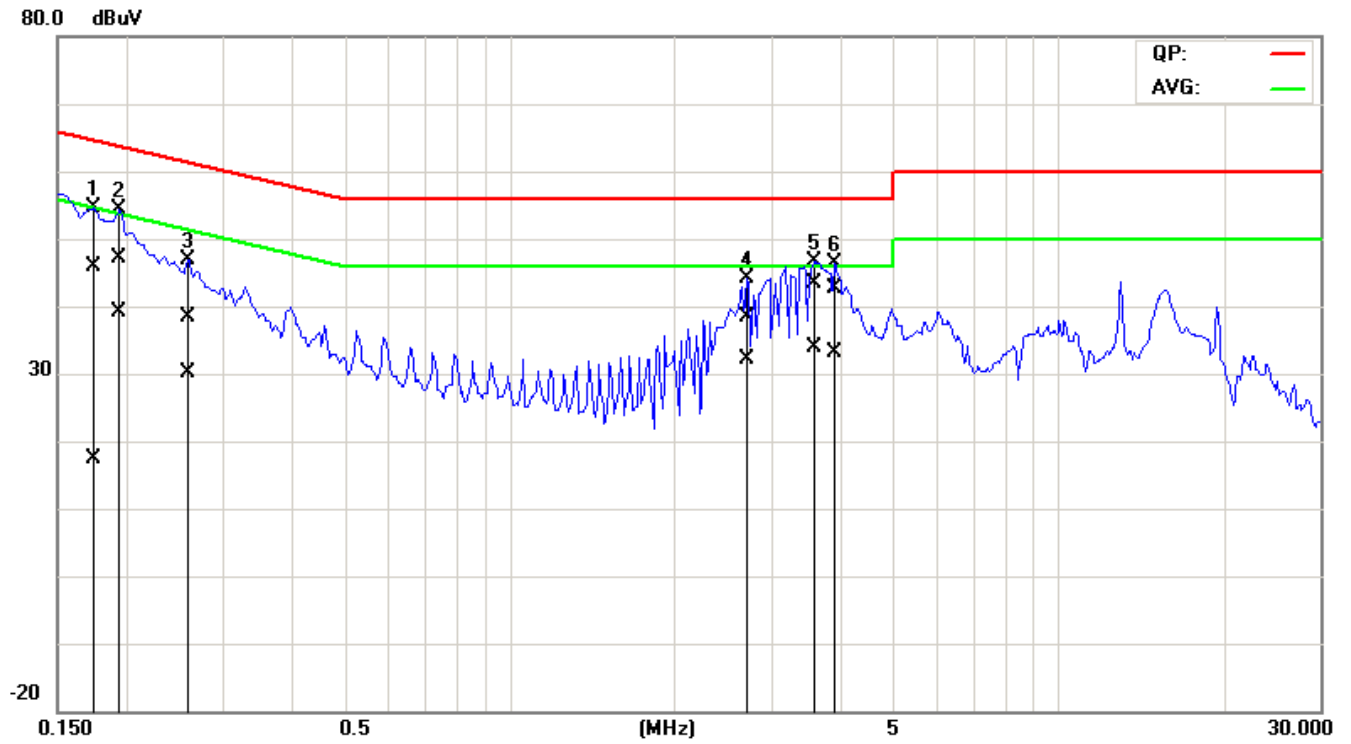

Conducted emissions (Line 2)

