

Title		
2.4GHz LNA		
Size	Document Number	Rev
B	1-LNA.SCH	1.0
Date:	Wednesday, April 08, 2009	Sheet 2 of 8

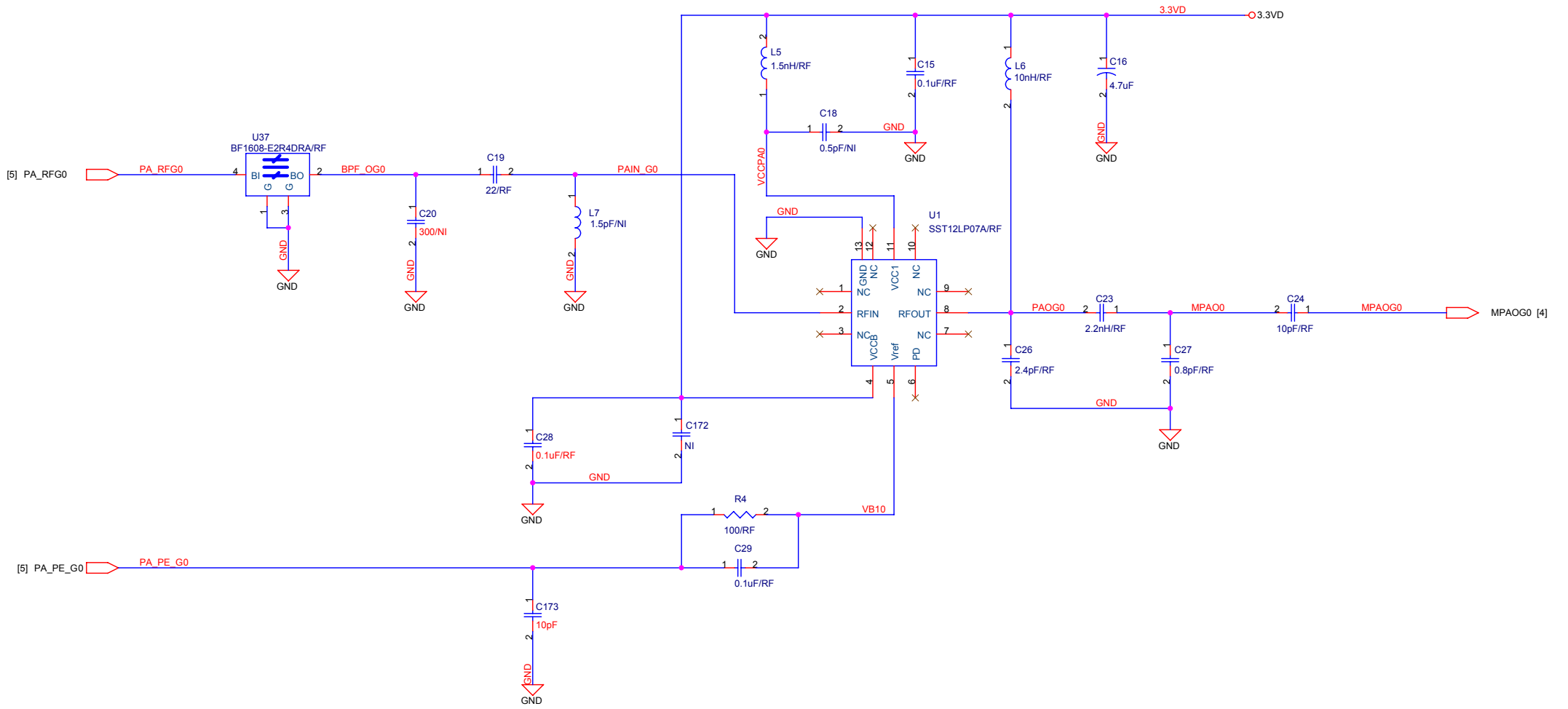

Title		2.4GHz PA	
Size	Document Number	Rev	
B	1-PA.SCH	1.0	
Date:	Wednesday, April 08, 2009	Sheet	3 of 8

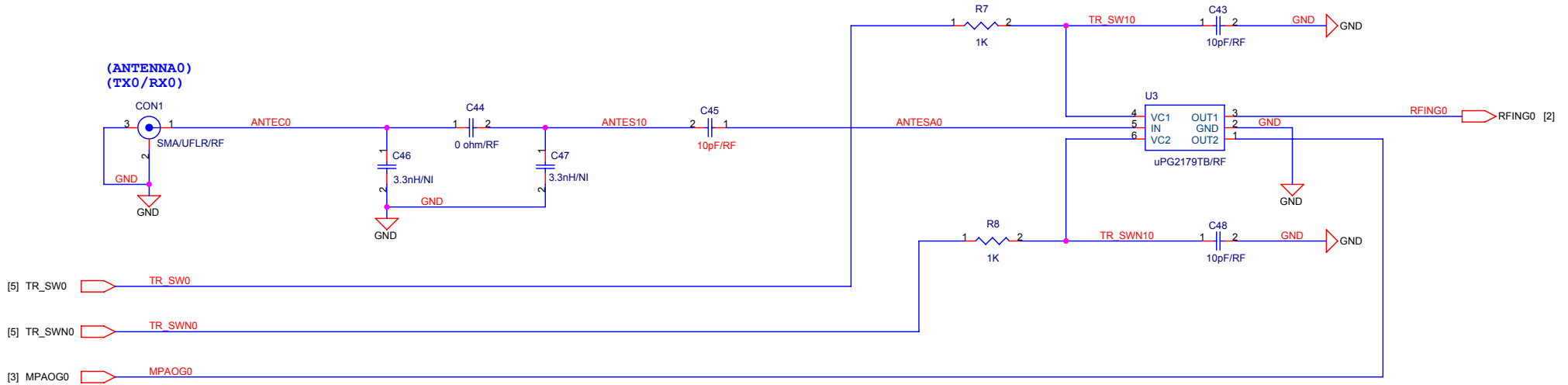

- [5] TR_SW0
- [5] TR_SWN0
- [3] MPAOG0

Title		Front-End
Size	Document Number	Rev
B	3-FrontEnd.SCH	1.0
Date:	Wednesday, April 08, 2009	Sheet 4 of 8

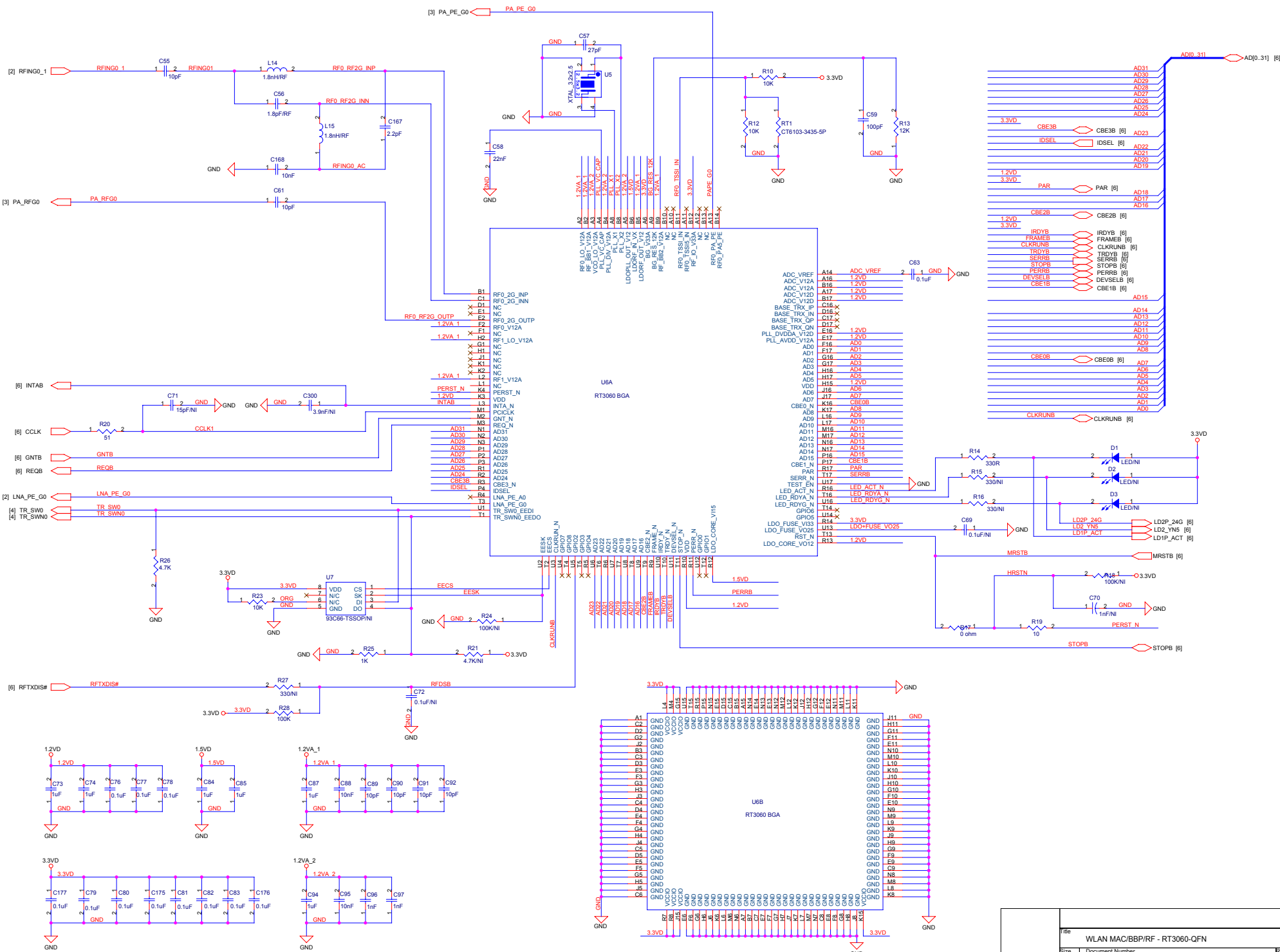

File	WLAN MAC/BBP/RF - RT3060-QFN	
Size	Document Number	Rev
C	4-RT3060-WLAN.SCH	1.0
Date	Wednesday, April 08, 2009	Sheet 5 of 8

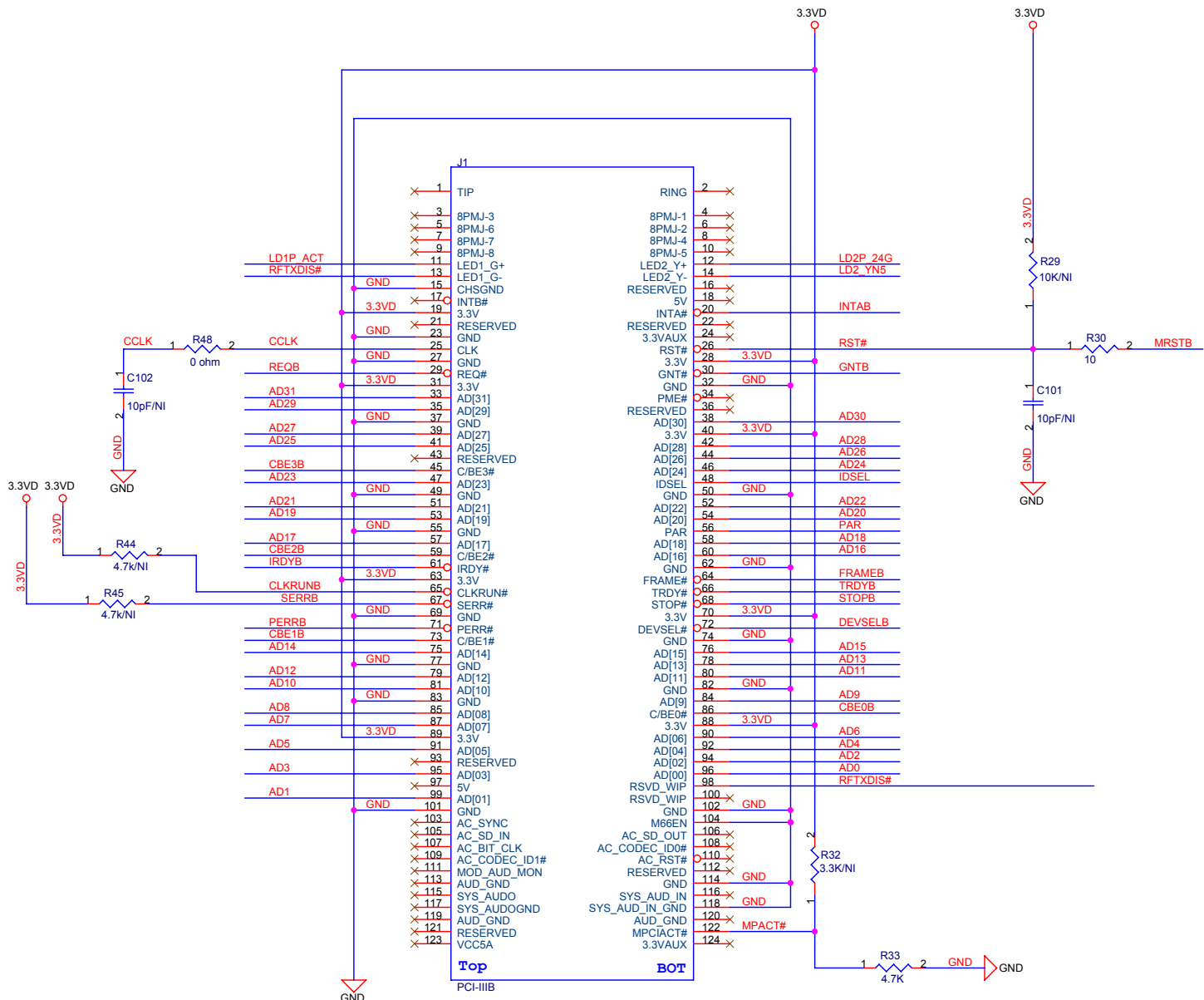

- GNTB [5]
- REQB [5]
- MRSTB [5]
- AD[0..31] [5]
- CBE0B [5]
- CBE1B [5]
- CBE2B [5]
- CBE3B [5]
- PAR [5]
- TRDYB [5]
- IRDYB [5]
- INTAB [5]
- IDSEL [5]
- STOPB [5]
- DEVSELB [5]
- PERRB [5]
- FRAMEB [5]
- SERRB [5]
- RFTXDIS# [5]
- LD1P_ACT [5]
- LD2P_24G [5]
- LD2_YN5 [5]
- CCLK [5]
- CLKRUNB [5]

Type IIIB

Title		
PCI Interface and Power		
Size	Document Number	Rev
B	5-PCI-3B.SCH	1.0
Date:	Wednesday, April 08, 2009	Sheet 6 of 8

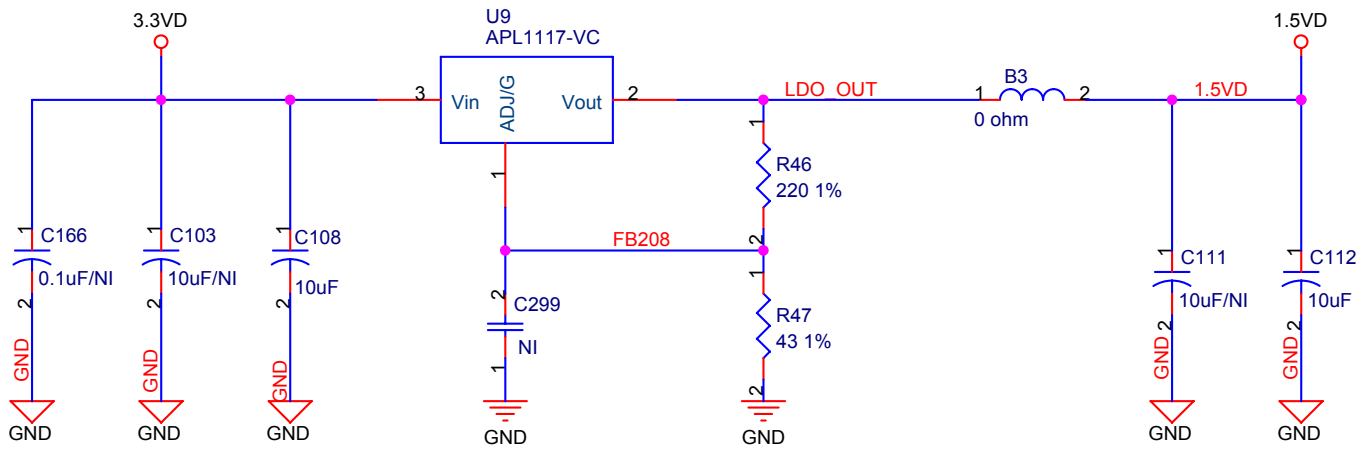

Title		
Power Supply		
Size	Document Number	Rev
A	6-POWER.SCH	1.0
Date:	Wednesday, April 08, 2009	Sheet 7 of 8