



# TEST REPORT

**Test Report No. : UL-RPT-RP11012145JD17A V3.0**

**Manufacturer** : SureFlap Ltd  
**Model No.** : HRP  
**FCC ID** : XO9-HR000N  
**Technology** : *Bluetooth* – Low Energy  
**Test Standard(s)** : FCC Parts 15.209(a) & 15.247

1. This test report shall not be reproduced in full or partial, without the written approval of UL VS LTD.
2. The results in this report apply only to the sample(s) tested.
3. The sample tested is in compliance with the above standard(s).
4. The test results in this report are traceable to the national or international standards.
5. Version 3.0 supersedes all previous versions.

**Date of Issue:** 27 October 2016

**Checked by:**

Ian Watch  
Senior Engineer, Radio Laboratory

**Company Signatory:**

Steven White  
Service Lead, Radio Laboratory  
UL VS LTD



This laboratory is accredited by UKAS.  
The tests reported herein have been  
performed in accordance with its terms  
of accreditation.

The *Bluetooth*<sup>®</sup> word mark and logos are owned by the *Bluetooth* SIG, Inc. and any use of such marks by UL VS LTD is under licence. Other trademarks and trade names are those of their respective owners.

---

## UL VS LTD

Pavilion A, Ashwood Park, Ashwood Way, Basingstoke, Hampshire, RG23 8BG, UK  
Telephone: +44 (0)1256 312000  
Facsimile: +44 (0)1256 312001

This page has been left intentionally blank.

**Table of Contents**

**1. Customer Information..... 4**

**2. Summary of Testing..... 5**

    2.1. General Information 5

    2.2. Summary of Test Results 5

    2.3. Methods and Procedures 5

    2.4. Deviations from the Test Specification 5

**3. Equipment Under Test (EUT) ..... 6**

    3.1. Identification of Equipment Under Test (EUT) 6

    3.2. Description of EUT 6

    3.3. Modifications Incorporated in the EUT 6

    3.4. Additional Information Related to Testing 7

    3.5. Support Equipment 7

**4. Operation and Monitoring of the EUT during Testing ..... 8**

    4.1. Operating Modes 8

    4.2. Configuration and Peripherals 8

**5. Measurements, Examinations and Derived Results ..... 9**

    5.1. General Comments 9

    5.2. Test Results 10

        5.2.1. Transmitter Minimum 6 dB Bandwidth 10

        5.2.2. Transmitter Maximum Peak Output Power 13

        5.2.3. Transmitter Radiated Emissions 16

        5.2.4. Transmitter Band Edge Radiated Emissions 24

**6. Measurement Uncertainty .....27**

**7. Report Revision History .....28**

**1. Customer Information**







<b>Company Name:</b>	SureFlap Ltd
<b>Address:</b>	7 The Irwin Centre Scotland Road Dry Drayton Cambridgeshire CB23 8AR United Kingdom

## 2. Summary of Testing

### 2.1. General Information

<b>Specification Reference:</b>	47CFR15.247
<b>Specification Title:</b>	Code of Federal Regulations Volume 47 (Telecommunications): Part 15 Subpart C (Intentional Radiators) - Section 15.247
<b>Specification Reference:</b>	47CFR15.209
<b>Specification Title:</b>	Code of Federal Regulations Volume 47 (Telecommunications): Part 15 Subpart C (Intentional Radiators) - Section 15.209
<b>Site Registration:</b>	209735
<b>Location of Testing:</b>	UL VS LTD, Unit 3 Horizon, Wade Road, Kingsland Business Park, Basingstoke, Hampshire, RG24 8AH, United Kingdom
<b>Test Dates:</b>	22 August 2016 to 09 September 2016

### 2.2. Summary of Test Results

FCC Reference (47CFR)	Measurement	Result
Part 15.247(a)(2)	Transmitter Minimum 6 dB Bandwidth	
Part 15.247(e)	Transmitter Power Spectral Density	Note 1
Part 15.247(b)(3)	Transmitter Maximum Peak Output Power	
Part 15.247(d)/15.209(a)	Transmitter Radiated Emissions	
Part 15.247(d)/15.209(a)	Transmitter Band Edge Radiated Emissions	
<b>Key to Results</b>		
 = Complied  = Did not comply		

#### Note(s):

- In accordance with FCC KDB 558074 Section 10.1, PSD is not required if the maximum conducted output power is less than the PSD limit of 8 dBm / 3 kHz. The PSD level is therefore deemed to be equal to the measured total output power.

### 2.3. Methods and Procedures

<b>Reference:</b>	ANSI C63.10-2013
<b>Title:</b>	American National Standard of Procedures for Compliance Testing of Unlicensed Wireless Devices
<b>Reference:</b>	KDB 558074 D01 DTS Meas Guidance v03r05 April 8, 2016
<b>Title:</b>	Guidance for Performing Compliance Measurements on Digital Transmission Systems (DTS) Operating Under §15.247

### 2.4. Deviations from the Test Specification

For the measurements contained within this test report, there were no deviations from, additions to, or exclusions from the test specification identified above.

### **3. Equipment Under Test (EUT)**

#### **3.1. Identification of Equipment Under Test (EUT)**

<b>Brand Name:</b>	SureSense Microchip Reader
<b>Model Name or Number:</b>	HRP
<b>Test Sample Serial Number:</b>	29 ( <i>Radiated sample</i> )
<b>Hardware Version:</b>	06
<b>Software Version:</b>	93
<b>FCC ID:</b>	XO9-HR000N

<b>Brand Name:</b>	SureSense Microchip Reader
<b>Model Name or Number:</b>	HRP
<b>Test Sample Serial Number:</b>	28 ( <i>Conducted sample</i> )
<b>Hardware Version:</b>	06
<b>Software Version:</b>	93
<b>FCC ID:</b>	XO9-HR000N

#### **3.2. Description of EUT**

The equipment under test was a *Bluetooth LE* enabled handheld microchip temperature reader.

#### **3.3. Modifications Incorporated in the EUT**

No modifications were applied to the EUT during testing.

**3.4. Additional Information Related to Testing**

<b>Technology Tested:</b>	<i>Bluetooth</i> Low Energy (Digital Transmission System)		
<b>Type of Unit:</b>	Transceiver		
<b>Channel Spacing:</b>	2 MHz		
<b>Modulation:</b>	GFSK		
<b>Data Rate:</b>	1 Mbps		
<b>Power Supply Requirement(s):</b>	Nominal	3.2 VDC	
<b>Maximum Conducted Output Power:</b>	-3.2 dBm		
<b>Antenna Gain:</b>	4.7 dBi		
<b>Transmit Frequency Range:</b>	2402 MHz to 2480 MHz		
<b>Transmit Channels Tested:</b>	<b>Channel ID</b>	<b>RF Channel</b>	<b>Channel Frequency (MHz)</b>
	Bottom	0	2402
	Middle	19	2440
	Top	39	2480

**3.5. Support Equipment**

The following support equipment was used to exercise the EUT during testing:

<b>Description:</b>	Dell
<b>Brand Name:</b>	Test Laptop
<b>Model Name or Number:</b>	E5410
<b>Serial Number:</b>	00732

<b>Description:</b>	Micro USB to USB Serial Cable
<b>Brand Name:</b>	Not marked or stated
<b>Model Name or Number:</b>	Not marked or stated
<b>Serial Number:</b>	Not marked or stated

<b>Description:</b>	USB extension cable (5 metres)
<b>Brand Name:</b>	Not marked or stated
<b>Model Name or Number:</b>	Not marked or stated
<b>Serial Number:</b>	Not marked or stated

## **4. Operation and Monitoring of the EUT during Testing**

### **4.1. Operating Modes**

The EUT was tested in the following operating mode(s):

- Transmitting at maximum power in *Bluetooth* LE mode with modulation, maximum possible data length available and Pseudorandom Bit Sequence 9.

### **4.2. Configuration and Peripherals**

The EUT was tested in the following configuration(s):

- Controlled using a terminal application supplied by the customer, called HCI tester, installed on a UL laptop PC. The application was used to enable continuous transmission and to select the test channels as required following instructions supplied in an email from the customer on 02-Dec-2015.
- Powered by 2 fully charged AA batteries. The battery voltage was monitored throughout testing.
- For radiated tests, the laptop was placed outside the anechoic chamber and connected to the EUT by the means of a USB extension cable.
- Radiated spurious emissions were performed with the EUT in its worst case position. There were no other ports left on the EUT to populate.
- The EUT conducted sample was used for 6 dB bandwidth and maximum peak output power tests.
- The EUT radiated sample was used for all other tests.



## **5. Measurements, Examinations and Derived Results**

### **5.1. General Comments**

Measurement uncertainties are evaluated in accordance with current best practice. Our reported expanded uncertainties are based on standard uncertainties, which are multiplied by an appropriate coverage factor to provide a statistical confidence level of approximately 95%. Please refer to *Section 6. Measurement Uncertainty* for details.

In accordance with UKAS requirements all the measurement equipment is on a calibration schedule. All equipment was within the calibration period on the date of testing.

## **5.2. Test Results**

### **5.2.1. Transmitter Minimum 6 dB Bandwidth**

#### **Test Summary:**

<b>Test Engineer:</b>	Stefan Ho	<b>Test Date:</b>	22 August 2016
<b>Test Sample Serial Number:</b>	28		

<b>FCC Reference:</b>	Part 15.247(a)(2)
<b>Test Method Used:</b>	FCC KDB 558074 Section 8.1 Option 2

#### **Environmental Conditions:**

<b>Temperature (°C):</b>	24
<b>Relative Humidity (%):</b>	35

#### **Note(s):**

1. 6 dB DTS bandwidth tests were performed using a test receiver in accordance with FCC KDB 558074 Section 8.1 Option 2 measurement procedure. The test receiver resolution bandwidth was set to 100 kHz and video bandwidth 300 kHz. A peak detector was used, sweep time was set to auto and the trace mode was Max Hold. The DTS bandwidth was measured at 6 dB down from the peak of the signal.
2. The test receiver was connected to the RF port on the EUT using suitable attenuation and RF cable.

#### **Test setup:**

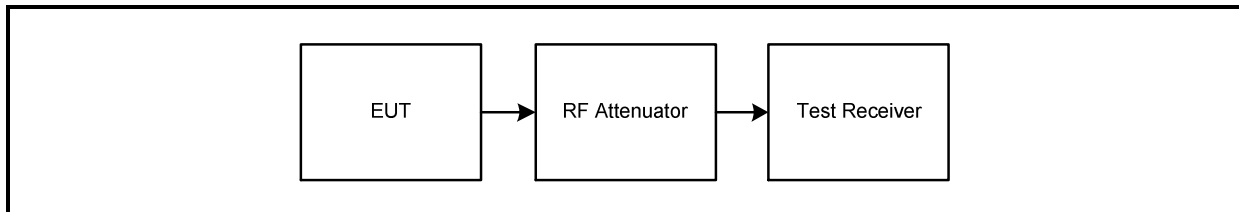

**Transmitter Minimum 6 dB Bandwidth (continued)**

**Results:**

Channel	6 dB Bandwidth (kHz)	Limit (kHz)	Margin (kHz)	Result
Bottom	714.744	≥500	214.744	Complied
Middle	724.359	≥500	224.359	Complied
Top	721.154	≥500	221.154	Complied

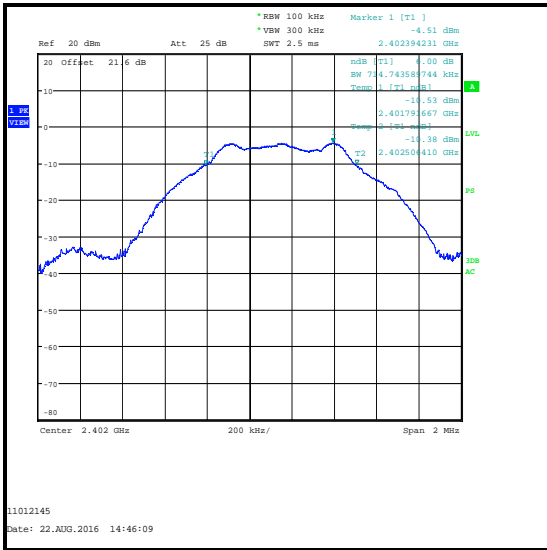

**Bottom Channel**

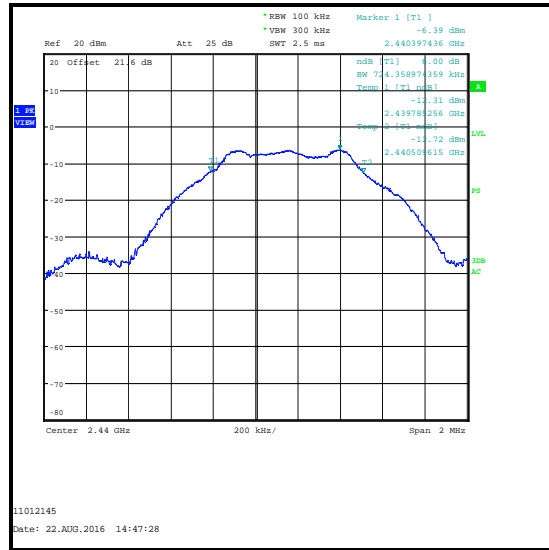

**Middle Channel**

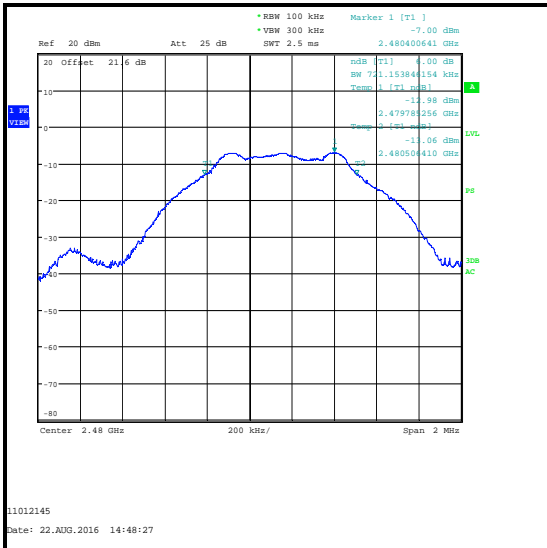

**Top Channel**

**Transmitter Minimum 6 dB Bandwidth (continued)****Test Equipment Used:**

Asset No.	Instrument	Manufacturer	Type No.	Serial No.	Date Calibration Due	Cal. Interval (Months)
M1630	Test Receiver	Rohde & Schwarz	ESU40	100233	17 Feb 2017	12
A2527	Attenuator	AtlanTecRF	AN18W5-20	832828#2	Calibrated before use	-
M1659	Thermohygrometer	JM Handelspunkt	30.5015.13	Not stated	02 April 2017	12
G0607	Signal Generator	Rohde & Schwarz	SMU200A	100943	10 May 2019	36
M199	Power Meter	Rohde & Schwarz	NRVS	827023/075	11 Apr 2018	24
M1267	Thermal Power Sensor	Rohde & Schwarz	NRV-Z52	100155	15 Apr 2018	24

**5.2.2. Transmitter Maximum Peak Output Power****Test Summary:**

<b>Test Engineer:</b>	Stefan Ho	<b>Test Date:</b>	22 August 2016
<b>Test Sample Serial Number:</b>	28		

<b>FCC Reference:</b>	Part 15.247(b)(3)
<b>Test Method Used:</b>	FCC KDB 558074 Section 9.1.1

**Environmental Conditions:**

<b>Temperature (°C):</b>	24
<b>Relative Humidity (%):</b>	37

**Note(s):**

1. Conducted power tests were performed using a test receiver in accordance with FCC KDB 558074 Section 9.1.1 with the RBW > *DTS bandwidth* procedure.
2. The test receiver resolution bandwidth was set to 1 MHz and video bandwidth of 3 MHz. A peak detector was used, sweep time was set to auto and trace mode was Max Hold. The span was set to 5 MHz. A marker was placed at the peak of the signal and the results recorded in the table below.
3. The test receiver was connected to the RF port on the EUT using suitable attenuation and RF cable. An RF level offset was entered on the test receiver to compensate for the loss of the attenuator and RF cable.
4. The conducted power was added to the declared antenna gain to obtain the EIRP.

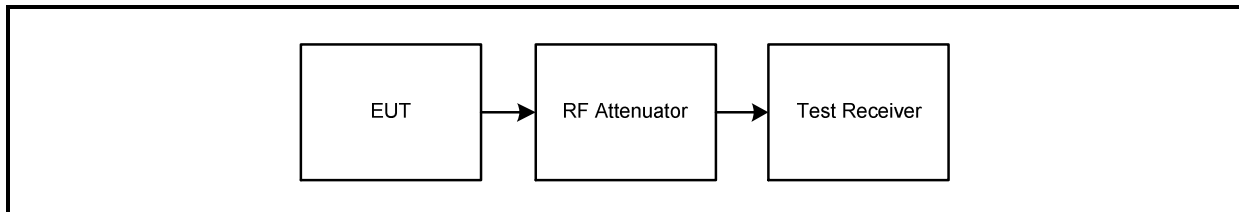
**Test setup:**

**Transmitter Maximum Peak Output Power (continued)****Results:**

Channel	Conducted Peak Power (dBm)	Conducted Peak Power Limit (dBm)	Margin (dB)	Result
Bottom	-3.2	30.0	33.2	Complied
Middle	-4.6	30.0	34.6	Complied
Top	-5.4	30.0	35.4	Complied

Channel	Conducted Peak Power (dBm)	Declared Antenna Gain (dBi)	EIRP (dBm)	De Facto EIRP Limit (dBm)	Margin (dB)	Result
Bottom	-3.2	4.7	1.5	36.0	34.5	Complied
Middle	-4.6	4.7	0.1	36.0	35.9	Complied
Top	-5.4	4.7	-0.7	36.0	36.7	Complied

**Transmitter Maximum Peak Output Power (continued)**

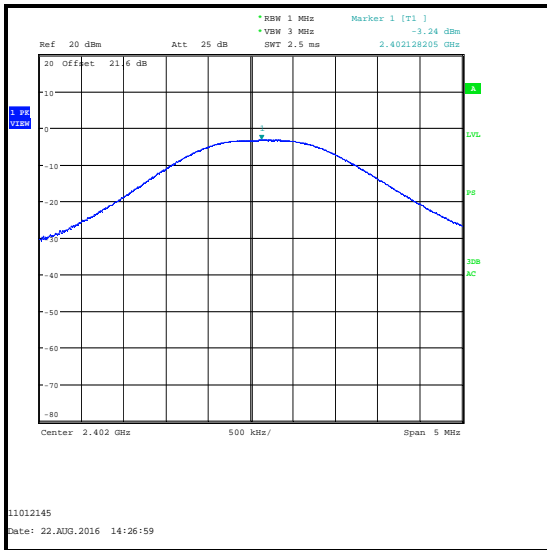

**Bottom Channel**

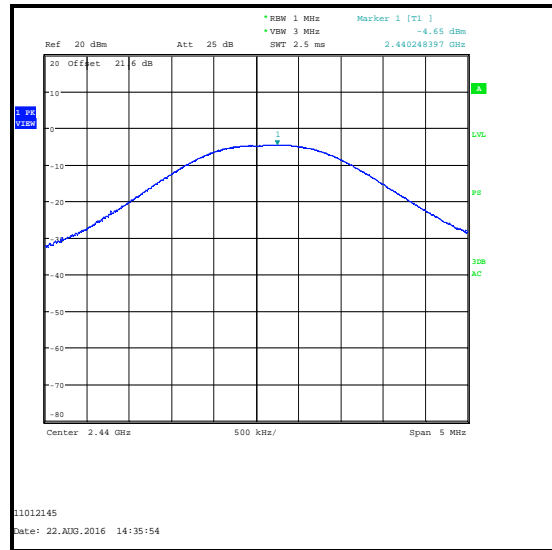

**Middle Channel**

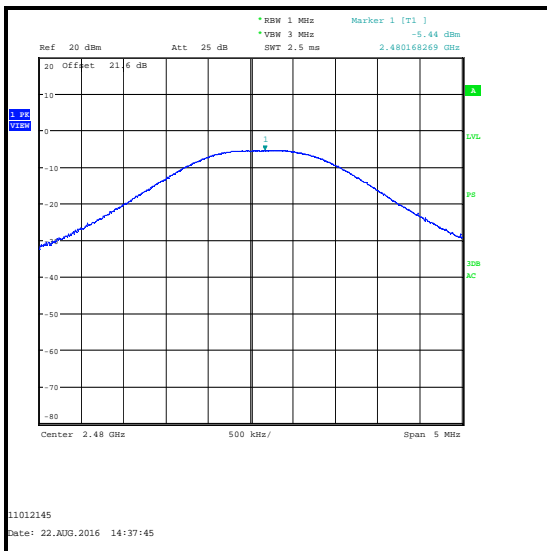

**Top Channel**

**Test Equipment Used:**

Asset No.	Instrument	Manufacturer	Type No.	Serial No.	Date Calibration Due	Cal. Interval (Months)
M1630	Test Receiver	Rohde & Schwarz	ESU40	100233	17 Feb 2017	12
A2527	Attenuator	AtlanTecRF	AN18W5-20	832828#2	Calibrated before use	-
M1659	Thermohygrometer	JM Handelspunkt	30.5015.13	Not stated	02 April 2017	12
G0607	Signal Generator	Rohde & Schwarz	SMU200A	100943	10 May 2019	36
M199	Power Meter	Rohde & Schwarz	NRVS	827023/075	11 Apr 2018	24
M1267	Thermal Power Sensor	Rohde & Schwarz	NRV-Z52	100155	15 Apr 2018	24

**5.2.3. Transmitter Radiated Emissions****Test Summary:**

<b>Test Engineer:</b>	John Ferdinand	<b>Test Date:</b>	07 September 2016
<b>Test Sample Serial Number:</b>	29		

<b>FCC Reference:</b>	Parts 15.247(d) & 15.209(a)
<b>Test Method Used:</b>	ANSI C63.10 Sections 6.3 and 6.5
<b>Frequency Range</b>	30 MHz to 1000 MHz

**Environmental Conditions:**

<b>Temperature (°C):</b>	21
<b>Relative Humidity (%):</b>	41

**Note(s):**

1. The final measured value, for the given emission, in the table below incorporates the calibrated antenna factor and cable loss.
2. The preliminary scans showed similar emission levels below 1 GHz, for each channel of operation. Therefore final radiated emissions measurements were performed with the EUT set to the middle channel only.
3. All emissions shown on the pre-scans were investigated and found to be ambient, or > 20 dB below the appropriate limit or below the noise floor of the measurement system. Therefore the highest peak noise floor reading of the measuring receiver was recorded in the table below.
4. Measurements below 1 GHz were performed in a semi-anechoic chamber (Asset Number K0001) at a distance of 3 metres. The EUT was placed at a height of 80 cm above the reference ground plane in the centre of the chamber turntable. Maximum emission levels were determined by height searching the measurement antenna over the range 1 metre to 4 metres.
5. Pre-scans were performed and markers placed on the highest measured levels. The test receiver resolution bandwidth was set to 100 kHz and video bandwidth 300 kHz. A peak detector was used, sweep time was set to auto and trace mode was Max Hold.
6. Final measurements were performed on the marker frequencies. The test receiver resolution bandwidth was set to 120 kHz, using a CISPR quasi-peak detector and span big enough to see the whole emission



**Transmitter Radiated Emissions (continued)**

**Test setup for radiated measurements:**

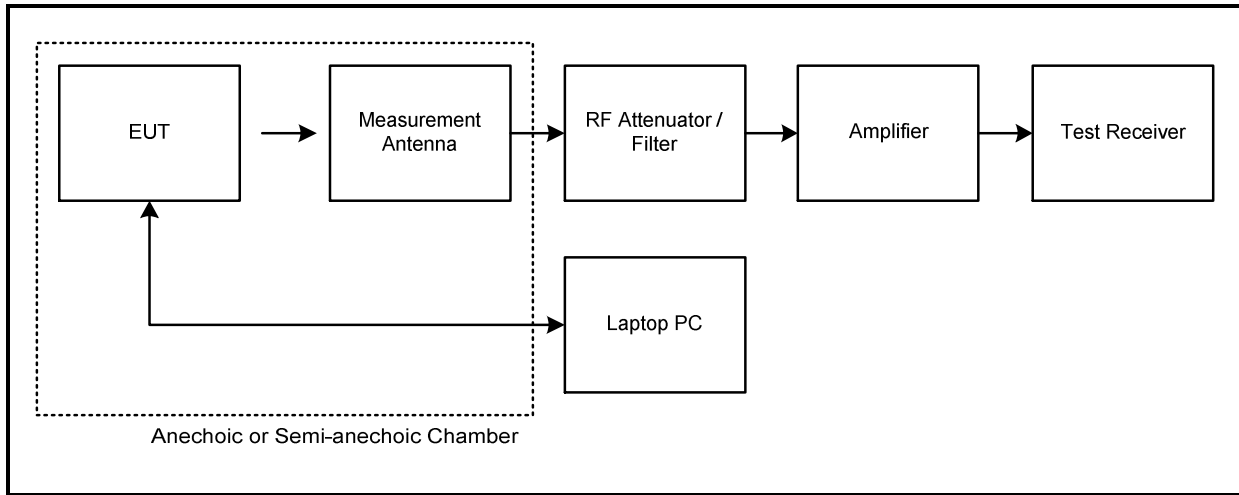

**Transmitter Radiated Emissions (continued)****Results: Middle Channel**

Frequency (MHz)	Antenna Polarity	Level (dB $\mu$ V/m)	Limit (dB $\mu$ V/m)	Margin (dB)	Result
984.569	Vertical	34.3	54.0	19.7	Complied

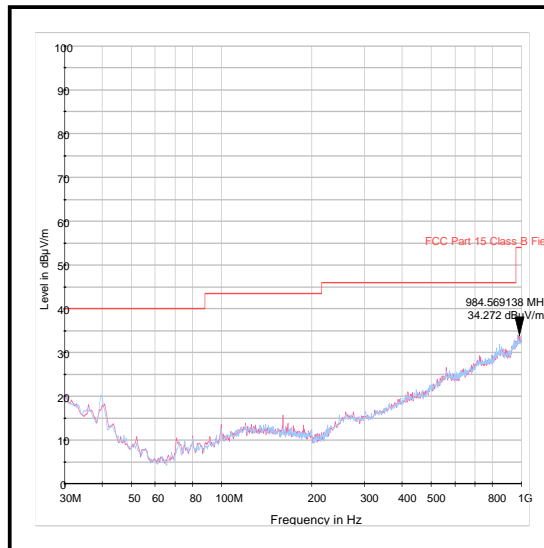
**Test Equipment Used:**

Asset No.	Instrument	Manufacturer	Type No.	Serial No.	Date Calibration Due	Cal. Interval (Months)
M1945	Thermohygrometer	JM Handelspunkt	30.5015.01	0112	10 Jun 2017	12
K0001	5m RSE Chamber	Rainford EMC	N/A	N/A	12 Jan 2017	12
G0543	Amplifier	Sonoma	310N	230801	09 Dec 2016	6
M1273	Test Receiver	Rohde & Schwarz	ESIB 26	100275	11 Apr 2017	12
A2959	Antenna	Schwarzbeck	VULB 9163	9163-967	22 Apr 2017	12
A1834	Attenuator	Hewlett Packard	8491B	10444	30 Mar 2017	12

**Transmitter Radiated Emissions (continued)****Test Summary:**

<b>Test Engineer:</b>	John Ferdinand	<b>Test Dates:</b>	08 September 2016 & 09 September 2016
<b>Test Sample Serial Number:</b>	29		

<b>FCC Reference:</b>	Parts 15.247(d) & 15.209(a)
<b>Test Method Used:</b>	FCC KDB 558074 Sections 11 & 12 referencing ANSI C63.10 Sections 6.3 and 6.6
<b>Frequency Range</b>	1 GHz to 25 GHz

**Environmental Conditions:**

<b>Temperature (°C):</b>	21 to 23
<b>Relative Humidity (%):</b>	39 to 41

**Note(s):**

1. The final measured value, for the given emission, in the table below incorporates the calibrated antenna factor and cable loss.
2. All other emissions shown on the pre-scan plot were investigated and found to be ambient or >20 dB below the applicable limit or below the measurement system noise floor.
3. The emission shown on the 1 GHz to 4 GHz plot is the EUT fundamental.
4. Pre-scans above 1 GHz were performed in a fully anechoic chamber (Asset Number K0002) at a distance of 3 metres. The EUT was placed at a height of 1.5 metres above the test chamber floor in the centre of the chamber turntable. All measurement antennas were placed at a fixed height of 1.5 metres above the test chamber floor, in line with the EUT. Final measurements above 1 GHz were performed at a height of 1.5 m above the reference ground plane in the centre of the chamber turntable. Maximum emission levels were determined by height searching the measurement antenna over the range 1 metre to 4 metres.
5. Pre-scans were performed and a marker placed on the highest measured level of the appropriate plot. The test receiver resolution bandwidth was set to 1 MHz and video bandwidth 3 MHz. The sweep time was set to auto.
6. In accordance with ANSI C63.10 Section 6.6.4.3, Note 1, if the peak measured value complies with the average limit, it is unnecessary to perform an average measurement.
7. The reference level for the emission in the non-restricted band was established by following KDB 558074 Section 11.2 procedure.

**Transmitter Radiated Emissions (continued)****Results: Peak / Bottom Channel**

Frequency (MHz)	Antenna Polarity	Peak Level (dB $\mu$ V/m)	Average Limit (dB $\mu$ V/m)	Margin (dB)	Result
4700.803	Vertical	46.9	54.0	7.1	Complied
4806.279	Vertical	45.9	54.0	8.1	Complied
4874.487	Vertical	47.5	54.0	6.5	Complied

**Results: Peak / Middle Channel**

Frequency (MHz)	Antenna Polarity	Peak Level (dB $\mu$ V/m)	Average Limit (dB $\mu$ V/m)	Margin (dB)	Result
4846.289	Vertical	46.6	54.0	7.4	Complied
4920.835	Vertical	48.9	54.0	5.1	Complied
4969.553	Vertical	48.3	54.0	5.7	Complied
5067.340	Vertical	49.9	54.0	4.1	Complied

**Results: Peak / Top Channel**

Frequency (MHz)	Antenna Polarity	Peak Level (dB $\mu$ V/m)	Average Limit (dB $\mu$ V/m)	Margin (dB)	Result
4875.288	Vertical	47.3	54.0	6.7	Complied
4960.801	Vertical	49.1	54.0	4.9	Complied
5004.006	Vertical	48.7	54.0	5.3	Complied
5067.885	Vertical	50.2	54.0	3.8	Complied

### Transmitter Radiated Emissions (continued)

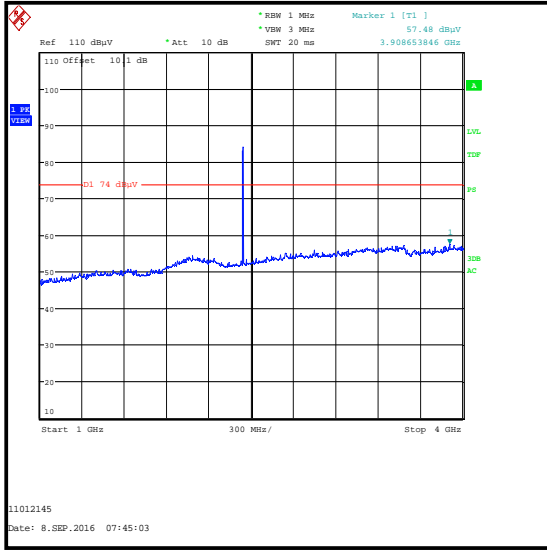

**Peak Detector**

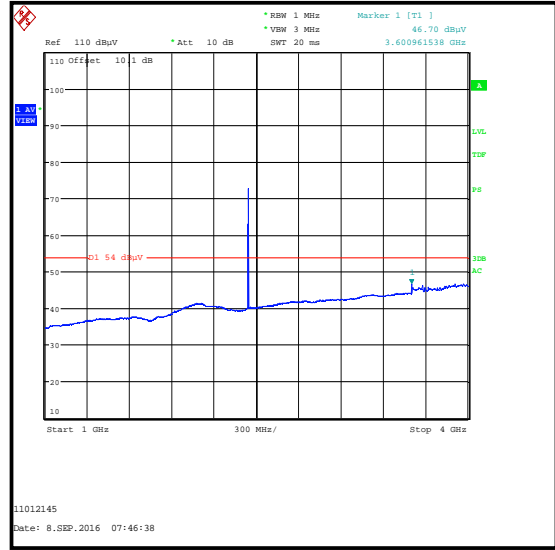

**Average Detector**

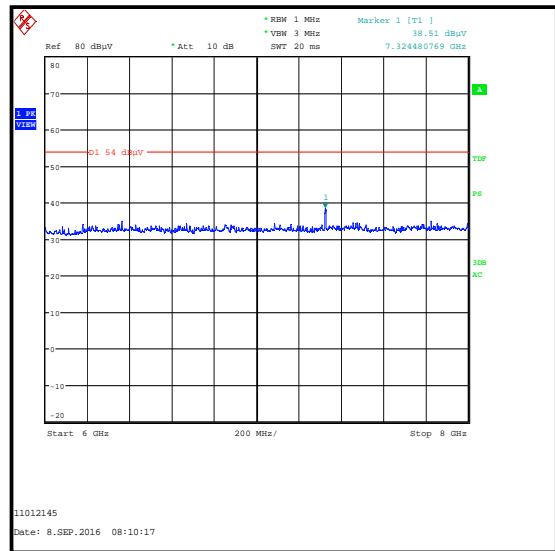
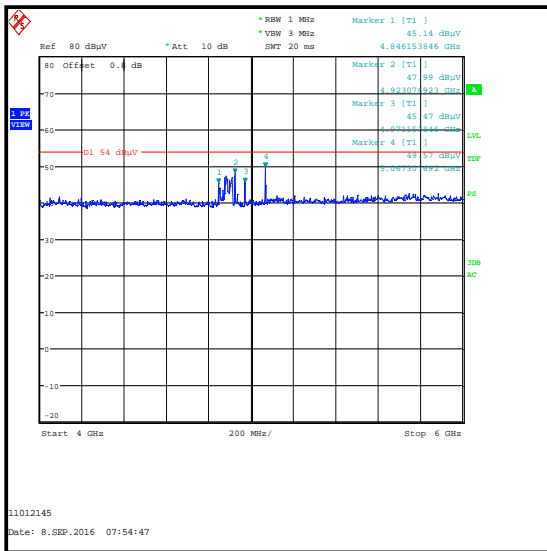

**Transmitter Radiated Emissions (continued)**

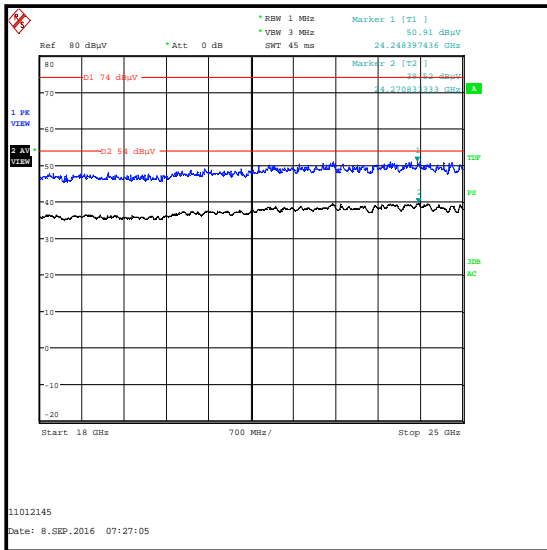
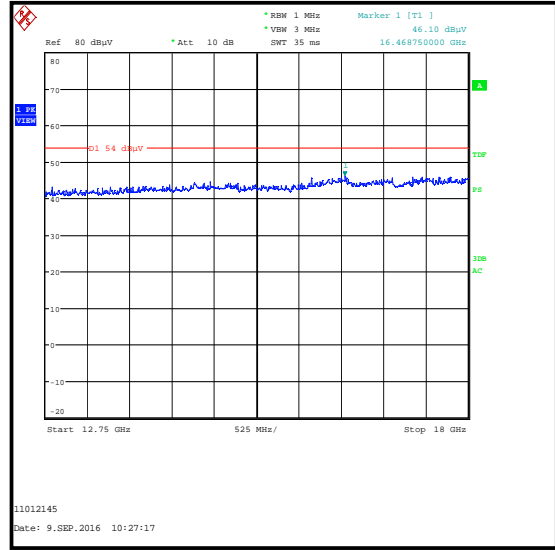
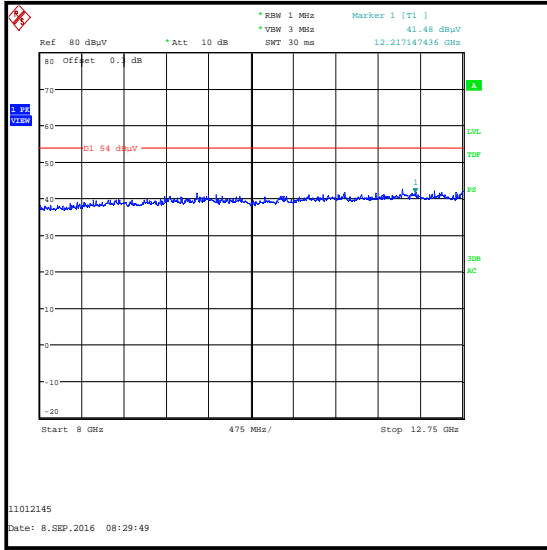

*Note: The above plots are pre-scans and for indication purposes only. For final measurements, see accompanying tables.*

**Transmitter Radiated Emissions (continued)****Test Equipment Used:**

Asset No.	Instrument	Manufacturer	Type No.	Serial No.	Date Calibration Due	Cal. Interval (Months)
M1656	Thermohygrometer	JM Handelspunkt	30.5015.13	Not stated	02 Apr 2017	12
K0002	3m RSE Chamber	Rainford EMC	N/A	N/A	21 Dec 2016	12
M1886	Test Receiver	Rohde & Schwarz	ESU26	100554	21 Mar 2017	12
A1534	Pre Amplifier	Hewlett Packard	8449B	3008A00405	19 Dec 2016	12
A1818	Antenna	EMCO	3115	00075692	17 Dec 2016	12
A253	Antenna	Flann Microwave	12240-20	128	17 Dec 2016	12
A254	Antenna	Flann Microwave	14240-20	139	17 Dec 2016	12
A255	Antenna	Flann Microwave	16240-20	519	17 Dec 2016	12
A256	Antenna	Flann Microwave	18240-20	400	17 Dec 2016	12
A436	Antenna	Flann Microwave	20240-20	330	17 Dec 2016	12
A239	Attenuator	Huber & Suhner	6806.17.B	Not stated	26 Apr 2017	12
A1975	High Pass Filter	AtlanTecRF	AFH-03000	090424010	26 Apr 2017	12

**5.2.4. Transmitter Band Edge Radiated Emissions****Test Summary:**

<b>Test Engineer:</b>	Stefan Ho	<b>Test Date:</b>	26 August 2016
<b>Test Sample Serial Number:</b>	29		

<b>FCC Reference:</b>	Parts 15.247(d) & 15.209(a)
<b>Test Method Used:</b>	ANSI C63.10 Section 6.10.4, 6.10.5 & KDB 558074 Section 11

**Environmental Conditions:**

<b>Temperature (°C):</b>	23
<b>Relative Humidity (%):</b>	55

**Note(s):**

1. The final measured value, for the given emission, in the table below incorporates the calibrated antenna factor and cable loss.
2. The maximum peak conducted output power was previously measured. In accordance with FCC KDB 558074 Section 11.1(a), the lower band edge measurement was performed with a peak detector and the -20 dBc limit applied.
3. As the lower band edge falls within a non-restricted band, only peak measurements are required. In accordance with FCC KDB 558074 Section 11.1, the test method in Section 11.3 was followed: the test receiver resolution bandwidth was set to 100 kHz and video bandwidth 300 kHz. A peak detector was used, sweep time was set to auto and trace mode was Max Hold. The test receiver was left to sweep for a sufficient length of time in order to maximise the carrier level and out-of-band emissions. A marker and corresponding reference level line were placed on the peak of the carrier. A marker was placed on the band edge spot frequencies and a second marker placed on the highest emission level in the adjacent non-restricted band of operation (where a higher level emission was present). Marker frequencies and levels were recorded.
4. As the upper band edge falls within a restricted band both peak and average measurements were recorded by placing a marker at the edge of the band. For peak measurements the test receiver resolution bandwidth was set to 1 MHz and the video bandwidth 3 MHz. A peak detector was used, sweep time was set to auto and trace mode was Max Hold. The test receiver was left to sweep for a sufficient length of time in order to maximise the carrier level and out-of-band emissions. For average measurements the test receiver resolution bandwidth was set to 1 MHz and the video bandwidth 3 MHz. An RMS detector was used, sweep time was set to auto and 300 traces performed. A marker was placed on the band edge spot frequencies and a second marker placed on the highest emission level in the adjacent restricted band of operation (where a higher level emission was present). Marker frequencies and levels were recorded.
5. There is a restricted band 10 MHz below the lower band edge. The test receiver was set up as follows: the RBW set to 1 MHz, the VBW set to 3 MHz, with the sweep time set to auto couple. Peak and average measurements were performed with their respective detectors. Markers were placed on the highest point on each trace.



**Transmitter Band Edge Radiated Emissions (continued)****Results: Lower Band Edge**

Frequency (MHz)	Level (dB $\mu$ V/m)	-20 dBc Limit (dB $\mu$ V/m)	Margin (dB)	Result
2399.439	60.5	73.5	13.0	Complied
2400.000	53.1	73.5	20.4	Complied

**Results: Upper Band Edge / Restricted Band / Peak**

Frequency (MHz)	Level (dB $\mu$ V/m)	Limit (dB $\mu$ V/m)	Margin (dB)	Result
2387.308	53.5	74.0	20.5	Complied
2483.500	59.3	74.0	14.7	Complied

**Results: Upper Band Edge / Restricted Band / Average**

Frequency (MHz)	Level (dB $\mu$ V/m)	Limit (dB $\mu$ V/m)	Margin (dB)	Result
2312.949	43.0	54.0	11.0	Complied
2483.500	47.0	54.0	7.0	Complied

**Transmitter Band Edge Radiated Emissions (continued)**

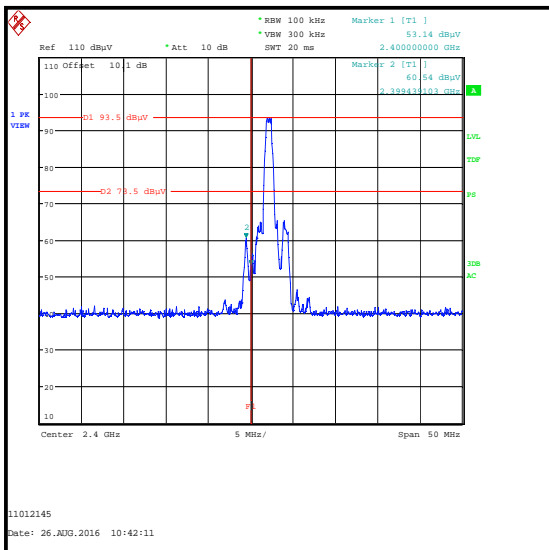

**Lower Band Edge Peak Measurement**

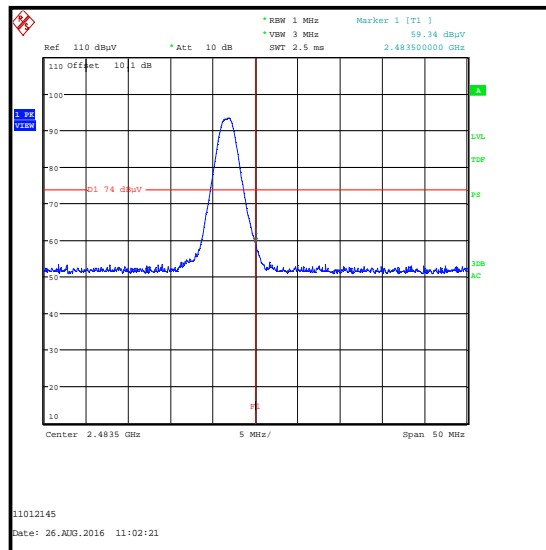

**Upper Band Edge Peak Measurement**

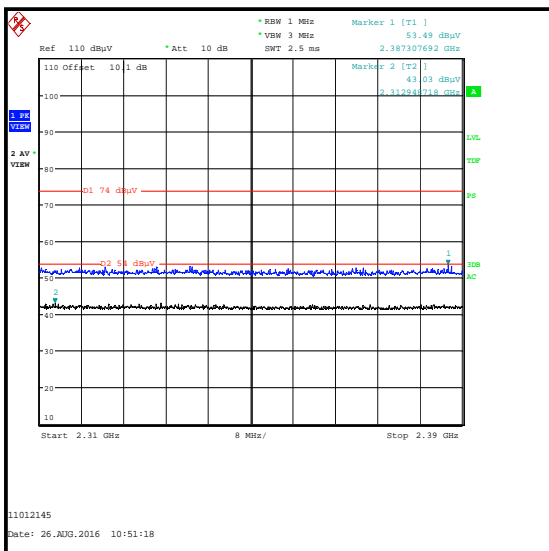

**2310 MHz to 2390 MHz Restricted Band Plot**

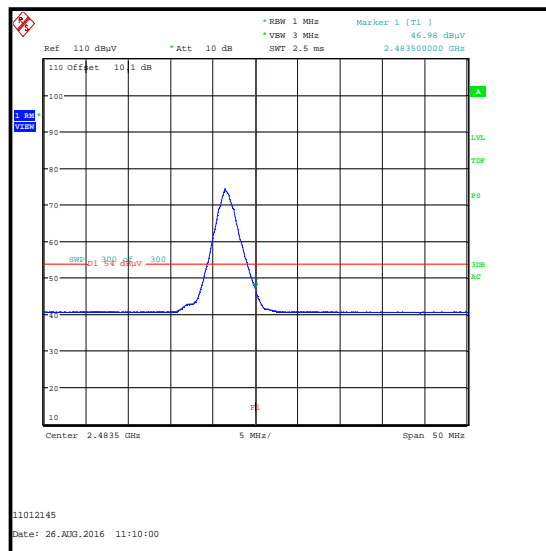

**Upper Band Edge Average Measurement**

**Test Equipment Used:**

Asset No.	Instrument	Manufacturer	Type No.	Serial No.	Date Calibration Due	Cal. Interval (Months)
M1656	Thermohyrometer	JM Handelspunkt	30.5015.13	Not stated	02 Apr 2017	12
K0002	3m RSE Chamber	Rainford EMC	N/A	N/A	21 Dec 2016	12
M1886	Test Receiver	Rohde & Schwarz	ESU26	100554	21 Mar 2017	12
A1534	Pre Amplifier	Hewlett Packard	8449B	3008A00405	19 Dec 2016	12
A1818	Antenna	EMCO	3115	00075692	17 Dec 2016	12
A239	Attenuator	Huber & Suhner	6806.17.B	Not stated	26 Apr 2017	12

## **6. Measurement Uncertainty**

No measurement or test can ever be perfect and the imperfections give rise to error of measurement in the results. Consequently the result of a measurement is only an approximation to the value measured (the specific quantity subject to measurement) and is only complete when accompanied by a statement of the uncertainty of the approximation.

The expression of uncertainty of a measurement result allows realistic comparison of results with reference values and limits given in specifications and standards.

The uncertainty of the result may need to be taken into account when interpreting the measurement results.

The reported expanded uncertainties below are based on a standard uncertainty multiplied by an appropriate coverage factor such that a confidence level of approximately 95% is maintained. For the purposes of this document "approximately" is interpreted as meaning "effectively" or "for most practical purposes".

<b>Measurement Type</b>	<b>Range</b>	<b>Confidence Level (%)</b>	<b>Calculated Uncertainty</b>
Conducted Maximum Peak Output Power	2.4 GHz to 2.4835 GHz	95%	±1.13 dB
Minimum 6 dB Bandwidth	2.4 GHz to 2.4835 GHz	95%	±4.59 %
Radiated Spurious Emissions	30 MHz to 1 GHz	95%	±5.65 dB
Radiated Spurious Emissions	1 GHz to 26.5 GHz	95%	±2.94 dB

The methods used to calculate the above uncertainties are in line with those recommended within the various measurement specifications. Where measurement specifications do not include guidelines for the evaluation of measurement uncertainty the published guidance of the appropriate accreditation body is followed.

## **7. Report Revision History**

<b>Version Number</b>	<b>Revision Details</b>		
	<b>Page No(s)</b>	<b>Clause</b>	<b>Details</b>
1.0	-	-	Initial Version
2.0	1 & 6	-	Changed model name from 'HRPB1N' to 'HRP'
3.0	6	-	Changed hardware and software versions

--- END OF REPORT ---