

FCC Measurement/Technical Report on

SPB620 module

FCC ID: X02-SPB620

IC: 8713A-SPB620

Test Report Reference: MDE_HDW_2304_FCC_01

Test Laboratory:

7layers GmbH
Borsigstrasse 11
40880 Ratingen
Germany



Deutsche
Akkreditierungsstelle
D-PL-12140-01-01
D-PL-12140-01-02
D-PL-12140-01-03

Note:

The following test results relate only to the devices specified in this document. This report shall not be reproduced in parts without the written approval of the test laboratory.

7layers GmbH
Borsigstraße 11
40880 Ratingen, Germany
T +49 (0) 2102 749 0
F +49 (0) 2102 749 350

Geschäftsführer/
Managing Directors:
Sebastian Doose
Stefan Kischka
Bernhard Retka

Registergericht/registered:
Düsseldorf HRB 75554
USt-Id.-Nr./VAT-No. DE203159652
Steuer-Nr./TAX-No. 147/5869/0385

a Bureau Veritas
Group Company

www.7layers.com

Table of Contents

1	Applied Standards and Test Summary	4
1.1	Applied Standards	4
1.2	FCC-IC Correlation Table	5
1.3	Measurement Summary	6
2	Revision History / Signatures	10
3	Administrative Data	11
3.1	Testing Laboratory	11
3.2	Project Data	11
3.3	Applicant Data	11
3.4	Manufacturer Data	12
4	Test object Data	13
4.1	General EUT Description	13
4.2	EUT Main components	13
4.3	Ancillary Equipment	14
4.4	Auxiliary Equipment	14
4.5	EUT Setups	14
4.6	Operating Modes / Test Channels	15
4.7	Duty cycle	15
4.8	Product labelling	16
5	Test Results	17
5.1	Conducted Emissions at AC Mains	17
5.2	Occupied Bandwidth (20 dB)	20
5.3	Occupied Bandwidth (99%)	24
5.4	Peak Power Output	27
5.5	Spurious RF Conducted Emissions	31
5.6	Transmitter Spurious Radiated Emissions	35
5.7	Band Edge Compliance Conducted	47
5.8	Band Edge Compliance Radiated	53
5.9	Channel Separation	61
5.10	Dwell Time	64
5.11	Number of Hopping Frequencies	67
6	Test Equipment	70
6.1	Test Equipment Hardware	70
6.2	Test Equipment Software	73
7	Antenna Factors, Cable Loss and Sample Calculations	74
7.1	LISN R&S ESH3-Z5 (150 kHz – 30 MHz)	74
7.2	Antenna R&S HFH2-Z2 (9 kHz – 30 MHz)	75
7.3	Antenna R&S HL562 (30 MHz – 1 GHz)	76
7.4	Antenna R&S HF907 (1 GHz – 18 GHz)	77
7.5	Antenna EMCO 3160-09 (18 GHz – 26.5 GHz)	78
7.6	Antenna EMCO 3160-10 (26.5 GHz – 40 GHz)	79

8	Measurement Uncertainties	80
9	Photo Report	82

1 APPLIED STANDARDS AND TEST SUMMARY

1.1 APPLIED STANDARDS

Type of Authorization

Certification for an Intentional Radiator.

Applicable FCC Rules

Prepared in accordance with the requirements of FCC Rules and Regulations as listed in 47 CFR Ch.1 Parts 2 and 15 (10-1-21 Edition). The following subparts are applicable to the results in this test report.

Part 2, Subpart J - Equipment Authorization Procedures, Certification

Part 15, Subpart C – Intentional Radiators

§ 15.201 Equipment authorization requirement

§ 15.207 Conducted limits

§ 15.209 Radiated emission limits; general requirements

§ 15.247 Operation within the bands 902-928 MHz, 2400-2483.5 MHz

Note:

The tests were selected and performed with reference to the FCC Public Notice "Guidance for Compliance Measurements on Digital Transmission System, Frequency Hopping Spread Spectrum System, and Hybrid System Devices Operating under Section 15.247 of the FCC Rules, 558074 D01 15.247 Meas Guidance v05r02, 2019-04-02". ANSI C63.10-2013 is applied.

1.2 FCC-IC CORRELATION TABLE

Correlation of measurement requirements for FHSS (e.g. Bluetooth®) equipment from FCC and IC

FHSS equipment		
Measurement	FCC reference	IC reference
Conducted emissions on AC Mains	§ 15.207	RSS-Gen Issue 5: 8.8
Occupied bandwidth	§ 15.247 (a) (1)	RSS-247 Issue 3: 5.1 (b)
Peak conducted output power	§ 15.247 (b) (1), (4)	RSS-247 Issue 3: 5.4 (b)
Transmitter spurious RF conducted emissions	§ 15.247 (d)	RSS-Gen Issue 5: 6.13/8.9/8.10; RSS-247 Issue 3: 5.5
Transmitter spurious radiated emissions	§ 15.247 (d); § 15.209 (a)	RSS-Gen Issue 5: 6.13 / 8.9/8.10; RSS-247 Issue 3: 5.5
Band edge compliance	§ 15.247 (d)	RSS-247 Issue 3: 5.5
Dwell time	§ 15.247 (a) (1) (iii)	RSS-247 Issue 3: 5.1 (d)
Channel separation	§ 15.247 (a) (1)	RSS-247 Issue 3: 5.1 (b)
No. of hopping frequencies	§ 15.247 (a) (1) (iii)	RSS-247 Issue 3: 5.1 (d)
Hybrid systems (only)	§ 15.247 (f); § 15.247 (e)	RSS-247 Issue 3: 5.3
Antenna requirement	§ 15.203 / 15.204	RSS-Gen Issue 5: 8.3
Receiver spurious emissions	-	-

1.3 MEASUREMENT SUMMARY

47 CFR CHAPTER I FCC PART 15 § 15.207 **Subpart C §15.247**

Conducted Emissions at AC Mains

The measurement was performed according to ANSI C63.10 6.2

Final Result

OP-Mode	Setup	Date	FCC	IC
Operating mode, Connection to AC mains worst case, via ancillary/auxiliary equipment	S04_AB01	2023-11-24	Passed	Passed

47 CFR CHAPTER I FCC PART 15 § 15.247 (a) (1) **Subpart C §15.247**

Occupied Bandwidth (20 dB)

The measurement was performed according to ANSI C63.10, chapter 6.9.2

Final Result

OP-Mode	Setup	Date	FCC	IC
Radio Technology, Operating Frequency				
Bluetooth BDR, high	S01_AB01	2023-08-18	Passed	Passed
Bluetooth BDR, low	S01_AB01	2023-08-18	Passed	Passed
Bluetooth BDR, mid	S01_AB01	2023-08-18	Passed	Passed
Bluetooth EDR 2, high	S01_AB01	2023-08-18	Passed	Passed
Bluetooth EDR 2, low	S01_AB01	2023-08-18	Passed	Passed
Bluetooth EDR 2, mid	S01_AB01	2023-08-18	Passed	Passed
Bluetooth EDR 3, high	S01_AB01	2023-08-18	Passed	Passed
Bluetooth EDR 3, low	S01_AB01	2023-08-18	Passed	Passed
Bluetooth EDR 3, mid	S01_AB01	2023-08-18	Passed	Passed

47 CFR CHAPTER I FCC PART 15 IC RSS-Gen & IC TRC-43; Ch. 6.7 & Ch. 8 **Subpart C §15.247**

Occupied Bandwidth (99%)

The measurement was performed according to ANSI C63.10, chapter 6.9.3

Final Result

OP-Mode	Setup	Date	FCC	IC
Radio Technology, Operating Frequency				
Bluetooth BDR, high	S01_AB01	2023-08-18	N/A	Performed
Bluetooth BDR, low	S01_AB01	2023-08-18	N/A	Performed
Bluetooth BDR, mid	S01_AB01	2023-08-18	N/A	Performed
Bluetooth EDR 2, high	S01_AB01	2023-08-18	N/A	Performed
Bluetooth EDR 2, low	S01_AB01	2023-08-18	N/A	Performed
Bluetooth EDR 2, mid	S01_AB01	2023-08-18	N/A	Performed
Bluetooth EDR 3, high	S01_AB01	2023-08-18	N/A	Performed
Bluetooth EDR 3, low	S01_AB01	2023-08-18	N/A	Performed
Bluetooth EDR 3, mid	S01_AB01	2023-08-18	N/A	Performed

47 CFR CHAPTER I FCC PART 15 § 15.247 (b) (1) (2) **Subpart C §15.247**

Peak Power Output

The measurement was performed according to ANSI C63.10, chapter 11.9.1.3

Final Result

OP-Mode Radio Technology, Operating Frequency, Measurement method	Setup	Date	FCC	IC
Bluetooth BDR, high, conducted	S01_AB01	2023-08-18	Passed	Passed
Bluetooth BDR, low, conducted	S01_AB01	2023-08-18	Passed	Passed
Bluetooth BDR, mid, conducted	S01_AB01	2023-08-18	Passed	Passed
Bluetooth EDR 2, high, conducted	S01_AB01	2023-08-18	Passed	Passed
Bluetooth EDR 2, low, conducted	S01_AB01	2023-08-18	Passed	Passed
Bluetooth EDR 2, mid, conducted	S01_AB01	2023-08-18	Passed	Passed
Bluetooth EDR 3, high, conducted	S01_AB01	2023-08-18	Passed	Passed
Bluetooth EDR 3, low, conducted	S01_AB01	2023-08-18	Passed	Passed
Bluetooth EDR 3, mid, conducted	S01_AB01	2023-08-18	Passed	Passed

47 CFR CHAPTER I FCC PART 15 § 15.247 (d)
Subpart C §15.247

Spurious RF Conducted Emissions

The measurement was performed according to ANSI C63.10, chapter 11.11

Final Result

OP-Mode Radio Technology, Operating Frequency	Setup	Date	FCC	IC
Bluetooth BDR, high	S01_AB01	2023-08-18	Passed	Passed
Bluetooth BDR, low	S01_AB01	2023-08-18	Passed	Passed
Bluetooth BDR, mid	S01_AB01	2023-08-18	Passed	Passed
Bluetooth EDR 2, high	S01_AB01	2023-08-18	Passed	Passed
Bluetooth EDR 2, low	S01_AB01	2023-08-18	Passed	Passed
Bluetooth EDR 2, mid	S01_AB01	2023-08-18	Passed	Passed
Bluetooth EDR 3, high	S01_AB01	2023-08-18	Passed	Passed
Bluetooth EDR 3, low	S01_AB01	2023-08-18	Passed	Passed
Bluetooth EDR 3, mid	S01_AB01	2023-08-18	Passed	Passed

47 CFR CHAPTER I FCC PART 15 § 15.247 (d)
Subpart C §15.247

Transmitter Spurious Radiated Emissions

The measurement was performed according to ANSI C63.10, chapter 6.4, 6.5, 6.6.5

Final Result

OP-Mode Radio Technology, Operating Frequency, Measurement range	Setup	Date	FCC	IC
Bluetooth BDR, high, 1 GHz - 26 GHz	S01_AB02	2023-08-22	Passed	Passed
Bluetooth BDR, high, 30 MHz - 1 GHz	S01_AB02	2023-08-31	Passed	Passed
Bluetooth BDR, low, 1 GHz - 26 GHz	S01_AB02	2023-08-20	Passed	Passed
Bluetooth BDR, low, 30 MHz - 1 GHz	S01_AB02	2023-08-31	Passed	Passed
Bluetooth BDR, mid, 1 GHz - 26 GHz	S01_AB02	2023-08-20	Passed	Passed
Bluetooth BDR, mid, 30 MHz - 1 GHz	S01_AB02	2023-08-31	Passed	Passed

47 CFR CHAPTER I FCC PART 15 § 15.247 (d)
Subpart C §15.247

Transmitter Spurious Radiated Emissions
The measurement was performed according to ANSI C63.10, chapter 6.4, 6.5, 6.6.5 **Final Result**

OP-Mode	Setup	Date	FCC	IC
Radio Technology, Operating Frequency, Measurement range				
Bluetooth BDR, mid, 9 kHz - 30 MHz	S01_AB02	2023-08-24	Passed	Passed
Bluetooth EDR 2, high, 1 GHz - 8 GHz	S01_AB02	2023-09-08	Passed	Passed
Bluetooth EDR 2, low, 1 GHz - 8 GHz	S01_AB02	2023-09-08	Passed	Passed
Bluetooth EDR 2, mid, 1 GHz - 8 GHz	S01_AB02	2023-09-08	Passed	Passed

47 CFR CHAPTER I FCC PART 15 § 15.247 (d)
Subpart C §15.247

Band Edge Compliance Conducted
The measurement was performed according to ANSI C63.10, chapter 11.11 **Final Result**

OP-Mode	Setup	Date	FCC	IC
Radio Technology, Operating Frequency, Band Edge				
Bluetooth BDR, high, high	S01_AB01	2023-08-18	Passed	Passed
Bluetooth BDR, hopping, high	S01_AB01	2023-08-18	Passed	Passed
Bluetooth BDR, hopping, low	S01_AB01	2023-08-18	Passed	Passed
Bluetooth BDR, low, low	S01_AB01	2023-08-18	Passed	Passed
Bluetooth EDR 2, high, high	S01_AB01	2023-08-18	Passed	Passed
Bluetooth EDR 2, hopping, high	S01_AB01	2023-08-18	Passed	Passed
Bluetooth EDR 2, hopping, low	S01_AB01	2023-08-18	Passed	Passed
Bluetooth EDR 2, low, low	S01_AB01	2023-08-18	Passed	Passed
Bluetooth EDR 3, high, high	S01_AB01	2023-08-18	Passed	Passed
Bluetooth EDR 3, hopping, high	S01_AB01	2023-08-18	Passed	Passed
Bluetooth EDR 3, hopping, low	S01_AB01	2023-08-18	Passed	Passed
Bluetooth EDR 3, low, low	S01_AB01	2023-08-18	Passed	Passed

47 CFR CHAPTER I FCC PART 15 § 15.247 (d)
Subpart C §15.247

Band Edge Compliance Radiated
The measurement was performed according to ANSI C63.10, chapter 6.6.5 **Final Result**

OP-Mode	Setup	Date	FCC	IC
Radio Technology, Operating Frequency, Band Edge				
Bluetooth BDR, high, high	S02_AB01	2023-08-22	Passed	Passed
Bluetooth EDR 2, high, high	S02_AB01	2023-09-08	Passed	Passed
Bluetooth EDR 3, high, high	S02_AB01	2023-10-17	Passed	Passed
Bluetooth BDR, high, high	S03_AB01	2023-10-17	Passed	Passed
Bluetooth EDR 3, high, high	S03_AB01	2023-10-17	Passed	Passed

47 CFR CHAPTER I FCC PART 15 § 15.247 (a) (1)
Subpart C §15.247

Channel Separation
 The measurement was performed according to ANSI C63.10, chapter 7.8.2 **Final Result**

OP-Mode	Setup	Date	FCC	IC
Radio Technology Bluetooth BDR	S01_AB01	2023-08-18	Passed	Passed

47 CFR CHAPTER I FCC PART 15 § 15.247 (a) (1) (i) (ii) (iii)
Subpart C §15.247

Dwell Time
 The measurement was performed according to ANSI C63.10, chapter 7.8.4 **Final Result**

OP-Mode	Setup	Date	FCC	IC
Radio Technology Bluetooth BDR	S01_AB01	2023-08-18	Passed	Passed

47 CFR CHAPTER I FCC PART 15 § 15.247 (a) (1) (i) (ii) (iii)
Subpart C §15.247

Number of Hopping Frequencies
 The measurement was performed according to ANSI C63.10, chapter 7.8.3 **Final Result**

OP-Mode	Setup	Date	FCC	IC
Radio Technology Bluetooth BDR	S01_AB01	2023-08-18	Passed	Passed

N/A: Not applicable
 N/P: Not performed

2 REVISION HISTORY / SIGNATURES

Report version control			
Version	Release date	Change Description	Version validity
initial	2023-12-18	--	valid
--	--	--	--

COMMENT: -



(responsible for accreditation scope)
Marco Kullik



(responsible for testing and report)
Mohamed Fraitat



7 layers GmbH, Borsigstr. 11
40880 Ratingen, Germany
Phone +49 (0)2102 749 0

3 ADMINISTRATIVE DATA

3.1 TESTING LABORATORY

Company Name: 7layers GmbH
Address: Borsigstr. 11
40880 Ratingen
Germany

The test facility is accredited by the following accreditation organisation:

Laboratory accreditation no: DAKKS D-PL-12140-01-01 | -02 | -03
FCC Designation Number: DE0015
FCC Test Firm Registration: 929146
ISED CAB Identifier DE0007; ISED#: 3699A

Responsible for accreditation scope: Marco Kullik
Report Template Version: 2023-09-29

3.2 PROJECT DATA

Responsible for testing and report: Mohamed Fraitat
Employees who performed the tests: documented internally at 7Layers
Date of Report: 2023-12-18
Testing Period: 2023-08-18 to 2023-09-08

3.3 APPLICANT DATA

Company Name: H&D Wireless AB
Address: Färögatan 33, Kista Science Tower
164 51 Kista
Sweden
Contact Person: Mikael Olsson

3.4 MANUFACTURER DATA

Company Name: please see Applicant Data

Address:

Contact Person:

4 TEST OBJECT DATA

4.1 GENERAL EUT DESCRIPTION

Kind of Device product description	Bluetooth and WiFi module.
Product name	SPB620 module
Type	SPB620
Declared EUT data by the supplier	
Voltage Type	DC
Voltage Level	3.3 V
Antenna / Gain	External / 3.8 dBi
Tested Modulation Type	BT Classic: GFSK (BDR), Pi/4 DQPSK (EDR 2), 8DPSK (EDR 3)
Specific product description for the EUT	The EUT is a Bluetooth and WLAN module. In the 2.4 GHz band the EUT supports MIMO Mode for WLAN. Supported technologies are Bluetooth Classic, Bluetooth Low Energy and WLAN b, g, n, ax 20 and 40 MHz bandwidth.
EUT ports (connected cables during testing):	- DC - Antenna
Tested datarates	BT Classic: GFSK modulation, 1 Mbit (BDR), π/4 DQPSK Modulation, 2 Mbit (EDR 2) 8-DPSK Modulation, 3 Mbit (EDR 3)
Special software used for testing	Labtool on computer board provided by applicant.

4.2 EUT MAIN COMPONENTS

Sample Name	Sample Code	Description
EUT AB01	DE1495002ab01	Radiated and conducted sample
Sample Parameter	Value	
Serial No.	13	
HW Version	R2B	
SW Version	MFG-W9098-MF-BRG-U16-WIN-X86-2.0.0.89-17.80.200.p225	
Comment		

NOTE: The short description is used to simplify the identification of the EUT in this test report.

4.3 ANCILLARY EQUIPMENT

For the purposes of this test report, ancillary equipment is defined as equipment which is used in conjunction with the EUT to provide operational and control features to the EUT. It is necessary to configure the system in a typical fashion, as a customer would normally use it. But nevertheless Ancillary Equipment can influence the test results.

Device	Details (Manufacturer, Type Model, OUT Code)	Description
-	-	-

4.4 AUXILIARY EQUIPMENT

For the purposes of this test report, auxiliary equipment is defined as equipment which is used temporarily to enable operational and control features especially used for the tests of the EUT which is not used during normal operation or equipment that is used during the tests in combination with the EUT but is not subject of this test report. It is necessary to configure the system in a typical fashion, as a customer would normally use it. But nevertheless Auxiliary Equipment can influence the test results.

Device	Details (Manufacturer, Type Model, HW, SW, S/N)	Description
AUX1	H&D Wireless, SPB437, -, -, -,	Evaluation Board for module providing ports
AUX2	Rasberry, Model 4, -, -, -,	Rasberry Pi 4 Test Jig
AUX3	Taoglas, GW.71.5153, -, -, -,	Dipole Antenna primary
AUX4	Taoglas, GW.71.5153, -, -, -,	Dipole Antenna primary
AUX5	TE Connectivity/Laird, 001-0012, -, -, -,	Dipole Antenna second
AUX6	TE Connectivity/Laird, 001-0012, -, -, -,	Dipole Antenna second
AUX7	PeakTech, 6005D (30 V / 5 A), -, -, 81062045	Lab Power Supply (provided by 7Layers).

4.5 EUT SETUPS

This chapter describes the combination of EUTs and equipment used for testing. The rationale for selecting the EUTs, ancillary and auxiliary equipment and interconnecting cables, is to test a representative configuration meeting the requirements of the referenced standards.

Setup	Combination of EUTs	Description and Rationale
S01_AB01	EUT AB01, AUX1, AUX2,	Setup for conducted measurements
S02_AB01	EUT AB01, AUX1, AUX2, AUX3, AUX4	Setup for radiated measurements
S03_AB01	EUT AB01, AUX1, AUX2, AUX5, AUX6	Setup for radiated measurements
S04_AB01	EUT AB01, AUX1, AUX2, AUX3, AUX4, AUX7	Setup for AC conducted

4.6 OPERATING MODES / TEST CHANNELS

This chapter describes the operating modes of the EUTs used for testing.

BT Test Channels:
Channel:
Frequency [MHz]

2.4 GHz ISM 2400 - 2483.5 MHz		
low	mid	high
0	39	78
2402	2441	2480

4.7 DUTY CYCLE

Test Mode	T _{on+off} (ms)	T _{on} (ms)	Duty cycle (%)
BT 1-DH5	3.75	2.88	76
BT 2-DH5	3.75	2.88	76
BT 3-DH5	3.75	2.88	76

BT 1-DH5

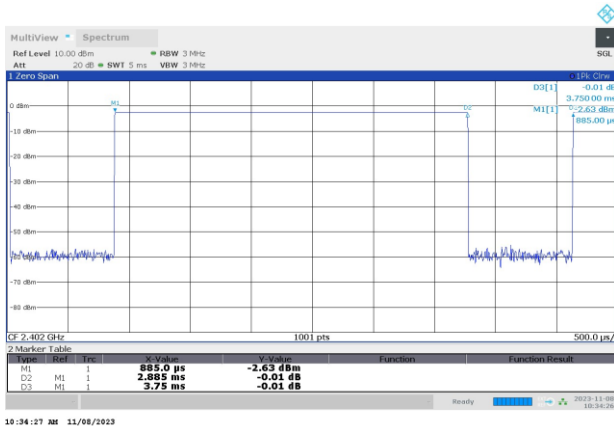

BT 2-DH5

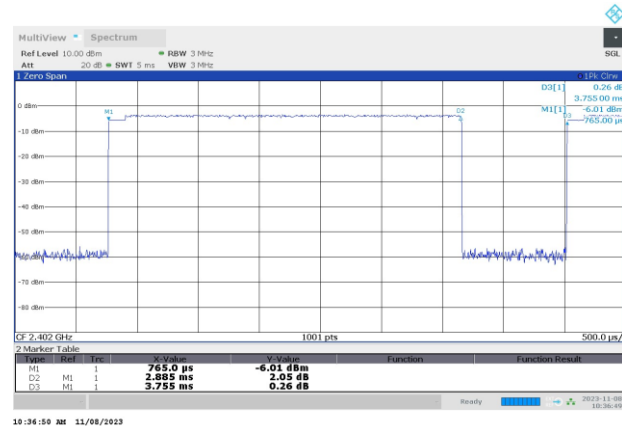

BT 3-DH5

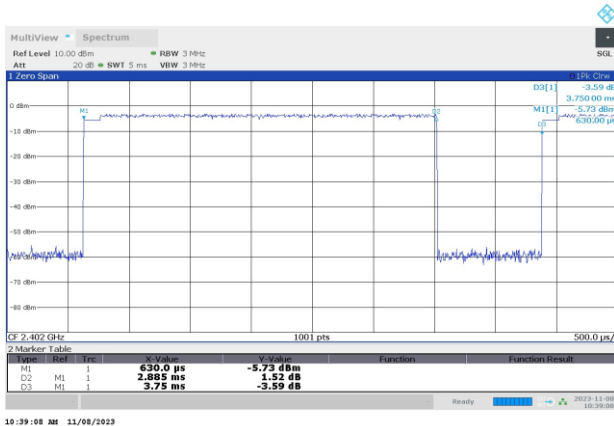

4.8 PRODUCT LABELLING

4.8.1 FCC ID LABEL

Please refer to the documentation of the applicant.

4.8.2 LOCATION OF THE LABEL ON THE EUT

Please refer to the documentation of the applicant.

5 TEST RESULTS

5.1 CONDUCTED EMISSIONS AT AC MAINS

Standard **FCC Part 15 Subpart C**

The test was performed according to:

ANSI C63.10 6.2

5.1.1 TEST DESCRIPTION

The test set-up was made in accordance to the general provisions of ANSI C 63.10. The Equipment Under Test (EUT) was setup in a shielded room to perform the conducted emissions measurements in a typical installation configuration. The EUT was powered from 50 μ H || 50 Ohm Line Impedance Stabilization Network (LISN). The LISN's unused connections were terminated with 50 Ohm loads.

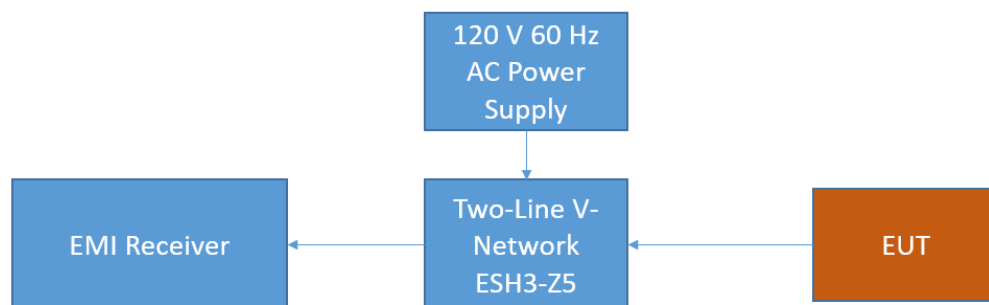

FCC Conducted Emissions on AC

The measurement procedure consists of two steps. It is implemented into the EMI test software EMC-32 from R&S.

Step 1: Preliminary scan

Intention of this step is, to determine the conducted EMI-profile of the EUT.

EMI receiver settings:

- Detector: Peak – Maxhold & Average
- Frequency range: 150 kHz – 30 MHz
- Frequency steps: 2.5 kHz
- IF-Bandwidth: 9 kHz
- Measuring time / Frequency step: 100 ms (FFT-based)
- Measurement on phase + neutral lines of the power cords

On basis of this preliminary scan the highest amplitudes and the corresponding frequencies relative to the limit are identified. Emissions above the limit and emissions which are in the 10 dB range below the limit are considered.

Step 2: Final measurement

Intention of this step is, to determine the highest emissions with the settings defined in the test specification for the frequencies identified in step 1.

EMI receiver settings:

- Detector: Quasi-Peak & (CISPR) Average
- IF Bandwidth: 9 kHz
- Measuring time: 1 s / frequency

At each frequency determined in step 1, four measurements are performed in the following combinations:

- 1) Neutral lead - reference ground (PE grounded)
- 2) Phase lead - reference ground (PE grounded)
- 3) Neutral lead - reference ground (PE floating)
- 4) Phase lead - reference ground (PE floating)

The highest value is reported.

5.1.2 TEST REQUIREMENTS / LIMITS

FCC Part 15, Subpart C, §15.207

Frequency (MHz)	QP Limits (dB μ V)	AV Limits (dB μ V)
0.15 - 0.5	66 - 56	56 - 46
0.5 - 5	56	46
5 - 30	60	50

Used conversion factor: Limit (dB μ V) = 20 log (Limit (μ V)/1 μ V).

5.1.3 TEST PROTOCOL

Temperature: 28 °C
 Air Pressure: 1018 hPa
 Humidity: 34 %

Power line	PE	Frequency [MHz]	Measured value QP [dB μ V]	Measured value AV [dB μ V]	Limit [dB μ V]	Margin [dB]
N	GND	-	-	-	-	< 6 dB
N	FLO	-	-	-	-	< 6 dB

Remark: Please see next sub-clause for the measurement plot.

5.1.4 MEASUREMENT PLOTS

Operating mode = worst case, Connection to AC mains = via ancillary/auxiliary equipment (S04_AB01)

Common Information

Test Description:	Conducted Emissions
Test Standard:	FCC §15.207, ANSI C63.10
EUT / Setup Code:	DE1495002ab01
Operating Conditions:	120 V 60 Hz, BT BDR TX on 2441 MHz
Comment:	AC mains connection via AUX5
Legend:	Trace: blue = QP, green = CISPR AV; Star: red or blue = critical frequency; Rhombus: blue = final QP, green = final CISPR AV
Tested Port / used LISN:	AC mains => 1st LISN ESH3-Z5
Termination of other ports:	N/A,

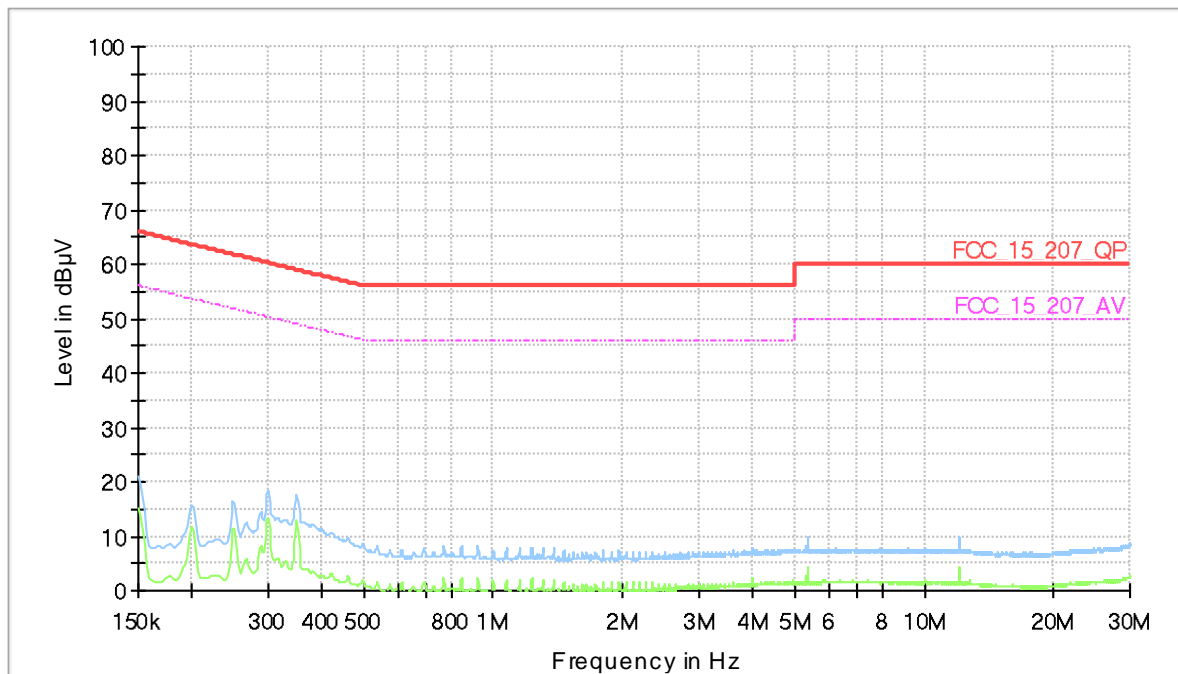

5.1.5 TEST EQUIPMENT USED

- Conducted Emissions FCC

5.2 OCCUPIED BANDWIDTH (20 DB)

Standard **FCC Part 15 Subpart C**

The test was performed according to:
ANSI C63.10, chapter 6.9.2

5.2.1 TEST DESCRIPTION

The Equipment Under Test (EUT) was set up to perform the occupied bandwidth measurements.

The reference level is the level of the highest amplitude signal observed from the transmitter at either the fundamental frequency or first-order modulation products in all typical modes of operation, including the unmodulated carrier, even if atypical.

The results recorded were measured with the modulation which produce the worst-case (widest) emission bandwidth.

The EUT was connected to the test system as described in the block diagram below. The complete attenuation of the measurement path is known and considered.

Analyser settings:

- Resolution Bandwidth (RBW): 1% to 5 % of the OBW
- Video Bandwidth (VBW): $\geq 3 \times$ RBW
- Span: 2 to 5 times the OBW
- Trace: Maxhold
- Sweeps: Till stable (min. 1000, max. 30000)
- Sweeptime: Auto
- Detector: Peak

The technology depending measurement parameters can be found in the measurement plot.

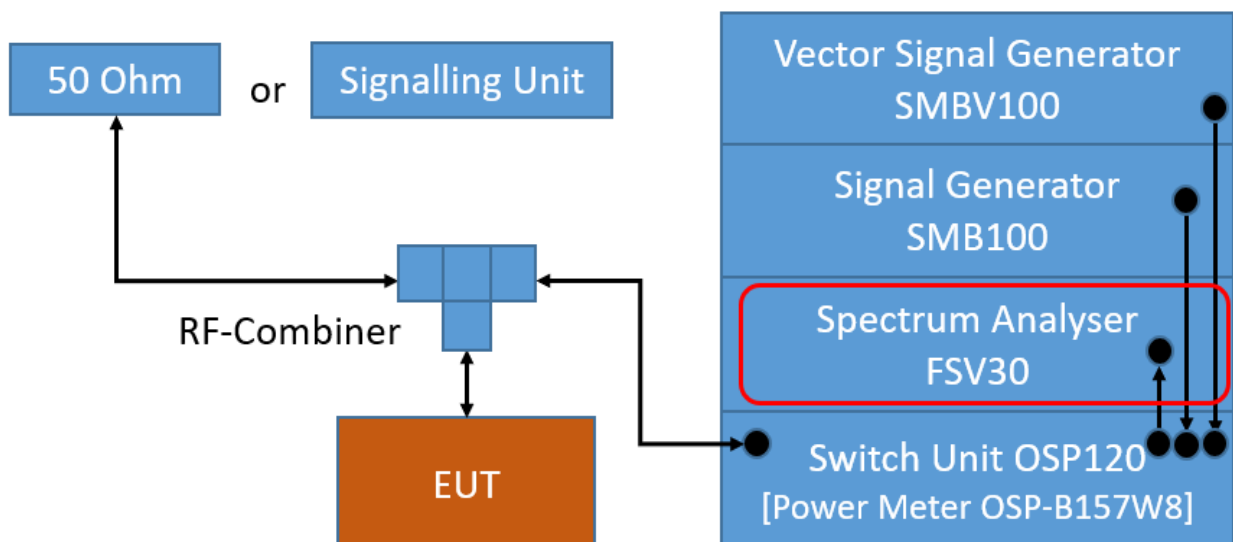

TS8997; Channel Bandwidth

5.2.2 TEST REQUIREMENTS / LIMITS

FCC Part 15, Subpart C, §15.247 (a) (2)

For the band: 902 – 928 MHz
FCC Part 15, Subpart C, §15.247 (a) (1) (i)

The maximum allowed 20 dB bandwidth of the hopping channel is 500 kHz

For the band: 5725 – 5850 MHz
FCC Part 15, Subpart C, §15.247 (a) (1) (ii)

The maximum allowed 20 dB bandwidth of the hopping channel is 1 MHz

For the frequency band 2400 – 2483.5 MHz:
FCC Part 15, Subpart C, §15.247 (a) (1) (iii)

Frequency hopping systems shall have hopping channel carrier frequencies separated by a minimum of 25 kHz or the 20 dB bandwidth of the hopping channel, whichever is greater. Alternatively, frequency hopping systems operating in the 2400–2483.5 MHz band may have hopping channel carrier frequencies that are separated by 25 kHz or two-thirds of the 20 dB bandwidth of the hopping channel, whichever is greater, provided the systems operate with an output power no greater than 125 mW. The system shall hop to channel frequencies that are selected at the system hopping rate from a pseudo randomly ordered list of hopping frequencies. Each frequency must be used equally on the average by each transmitter. The system receivers shall have input bandwidths that match the hopping channel bandwidths of their corresponding transmitters and shall shift frequencies in synchronization with the transmitted signals.

Implication by the test laboratory:

Since the Bluetooth technology defines a fixed channel separation of 1 MHz this design parameter defines the maximum allowed occupied bandwidth depending on the EUT's output power:

1. Under the provision that the system operates with an output power not greater than 125 mW (21.0 dBm):

Implicit Limit: Max. 20 dB BW = $1.0 \text{ MHz} / 2/3 = 1.5 \text{ MHz}$

2. If the system output power exceeds 125 mW (21.0 dBm):

Implicit Limit: Max. 20 dB BW = 1.0 MHz

Used conversion factor: Output power (dBm) = $10 \log (\text{Output power (W)} / 1\text{mW})$

The measured output power of the system is below 125 mW (21.0 dBm). For the results, please refer to the related chapter of this report.

Therefore the limit is determined as 1.5 MHz.

5.2.3 TEST PROTOCOL

Ambient temperature: 25 °C
 Air Pressure: 905 hPa
 Humidity: 40 %
 BT GFSK (1-DH5)

Band	Channel No.	Frequency [MHz]	20 dB Bandwidth [MHz]	Limit [MHz]	Margin to Limit [MHz]
2.4 GHz ISM	0	2402	0,930	1,470	0,540
	39	2441	0,935	1,470	0,535
	78	2480	0,930	1,470	0,540

BT n/4 DQPSK (2-DH5)

Band	Channel No.	Frequency [MHz]	20 dB Bandwidth [MHz]	Limit [MHz]	Margin to Limit [MHz]
2.4 GHz ISM	0	2402	1,325	1,470	0,145
	39	2441	1,325	1,470	0,145
	78	2480	1,325	1,470	0,145

BT 8-DPSK (3-DH5)

Band	Channel No.	Frequency [MHz]	20 dB Bandwidth [MHz]	Limit [MHz]	Margin to Limit [MHz]
2.4 GHz ISM	0	2402	1,275	1,470	0,195
	39	2441	1,270	1,470	0,200
	78	2480	1,270	1,470	0,200

Remark: Please see next sub-clause for the measurement plot.

5.2.4 MEASUREMENT PLOT (EXAMPLE PLOT, SHOWING WORST CASE, IF APPLICABLE)

Radio Technology = Bluetooth BDR, Operating Frequency = low

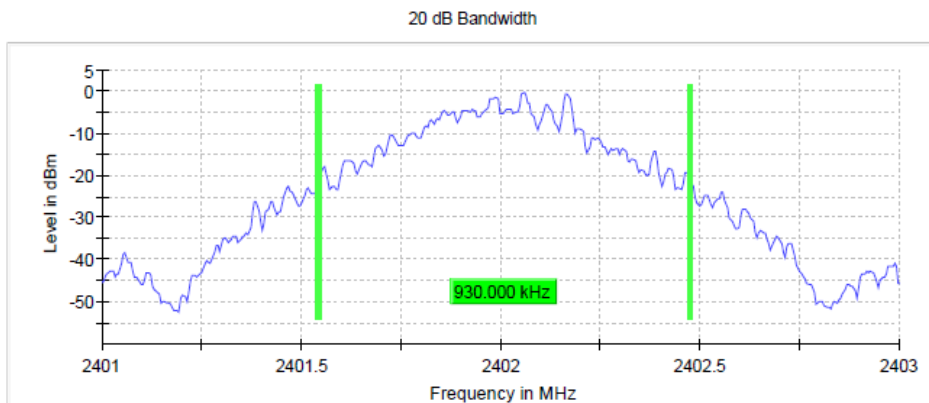

Measurement

Setting	Instrument Value
Start Frequency	2.40100 GHz
Stop Frequency	2.40300 GHz
Span	2.000 MHz
RBW	10.000 kHz
VBW	30.000 kHz
SweepPoints	400
SweepTime	419.000 μ s
Reference Level	0.000 dBm
Attenuation	10.000 dB
Detector	MaxPeak
SweepCount	200
Filter	3 dB
Trace Mode	Max Hold
SweepType	FFT
Preamp	off
Stablemode	Trace
Stablevalue	0.50 dB
Run	10 / max. 150
Stable	5 / 5
Max Stable Difference	0.04 dB

Radio Technology = Bluetooth BDR, Operating Frequency = mid

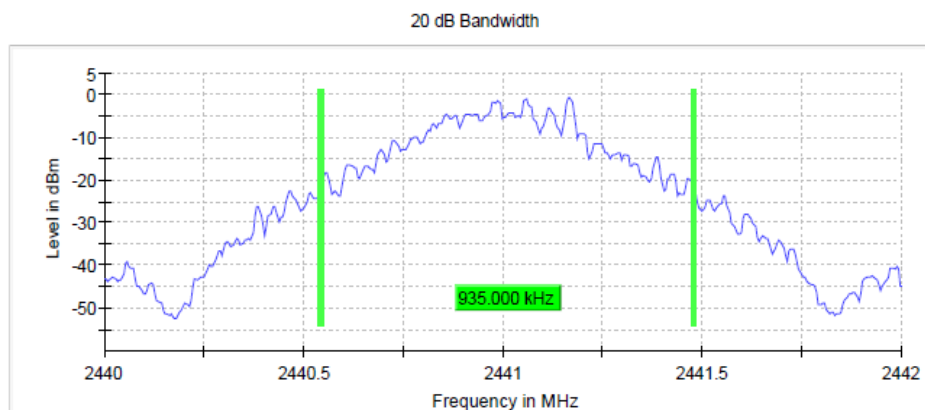

Measurement

Setting	Instrument Value
Start Frequency	2.44000 GHz
Stop Frequency	2.44200 GHz
Span	2.000 MHz
RBW	10.000 kHz
VBW	30.000 kHz
SweepPoints	400
SweepTime	419.000 μ s
Reference Level	0.000 dBm
Attenuation	10.000 dB
Detector	MaxPeak
SweepCount	200
Filter	3 dB
Trace Mode	Max Hold
SweepType	FFT
Preamp	off
Stablemode	Trace
Stablevalue	0.50 dB
Run	8 / max. 150
Stable	5 / 5
Max Stable Difference	0.04 dB

Radio Technology = Bluetooth BDR, Operating Frequency = high

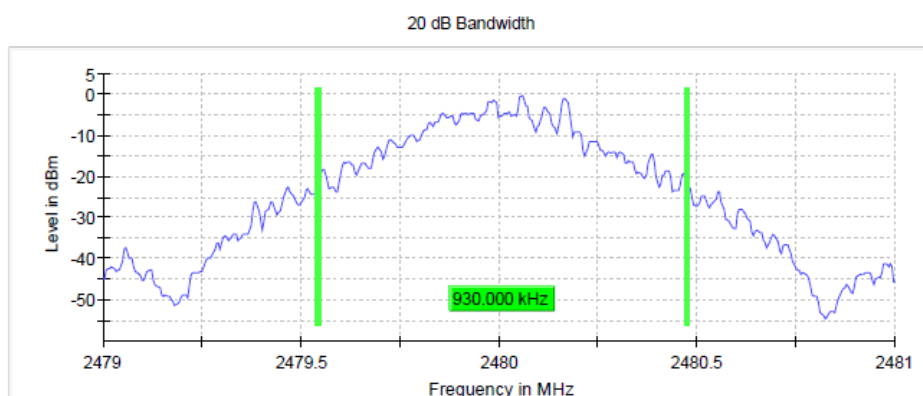

Measurement

Setting	Instrument Value
Start Frequency	2.47900 GHz
Stop Frequency	2.48100 GHz
Span	2.000 MHz
RBW	10.000 kHz
VBW	30.000 kHz
SweepPoints	400
SweepTime	419.000 μ s
Reference Level	0.000 dBm
Attenuation	10.000 dB
Detector	MaxPeak
SweepCount	200
Filter	3 dB
Trace Mode	Max Hold
SweepType	FFT
Preamp	off
Stablemode	Trace
Stablevalue	0.50 dB
Run	9 / max. 150
Stable	5 / 5
Max Stable Difference	0.05 dB

5.2.5 TEST EQUIPMENT USED

- R&S TS8997

5.3 OCCUPIED BANDWIDTH (99%)

Standard **FCC Part 15 Subpart C**

The test was performed according to:
ANSI C63.10, chapter 6.9.3

5.3.1 TEST DESCRIPTION

The Equipment Under Test (EUT) was set up to perform the occupied bandwidth measurements.

The reference level is the level of the highest amplitude signal observed from the transmitter at either the fundamental frequency or first-order modulation products in all typical modes of operation, including the unmodulated carrier, even if atypical.

The EUT was connected to the test system as described in the block diagram below. The complete attenuation of the measurement path is known and considered.

Analyser settings:

- Resolution Bandwidth (RBW): 1 to 5 % of the OBW
- Video Bandwidth (VBW): ≥ 3 times the RBW
- Span: 1.5 to 5 times the OBW
- Trace: Maxhold
- Sweeps: Till stable (min. 500, max. 75000)
- Sweep time: Auto
- Detector: Peak

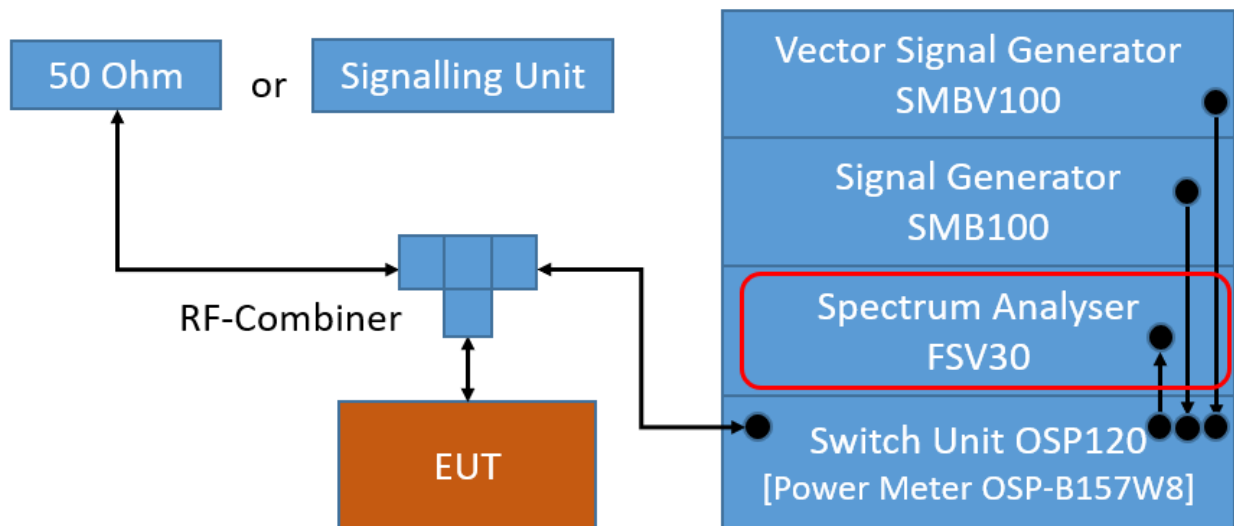

TS8997; Channel Bandwidth

5.3.2 TEST REQUIREMENTS / LIMITS

No applicable limit:

5.3.3 TEST PROTOCOL

Ambient temperature: 25 °C
 Air Pressure: 905 hPa
 Humidity: 40 %
 BT GFSK (1-DH5)

Band	Channel No.	Frequency [MHz]	99 % Bandwidth [MHz]
2.4 GHz ISM	0	2402	0,800
	39	2441	0,805
	78	2480	0,805

BT n/4 DQPSK (2-DH5)

Band	Channel No.	Frequency [MHz]	99 % Bandwidth [MHz]
2.4 GHz ISM	0	2402	1,170
	39	2441	1,170
	78	2480	1,170

BT 8-DPSK (3-DH5)

Band	Channel No.	Frequency [MHz]	99 % Bandwidth [MHz]
2.4 GHz ISM	0	2402	1,175
	39	2441	1,175
	78	2480	1,175

Remark: Please see next sub-clause for the measurement plot.

5.3.4 MEASUREMENT PLOT (EXAMPLE PLOT, SHOWING WORST CASE, IF APPLICABLE)

Radio Technology = Bluetooth BDR, Operating Frequency = low

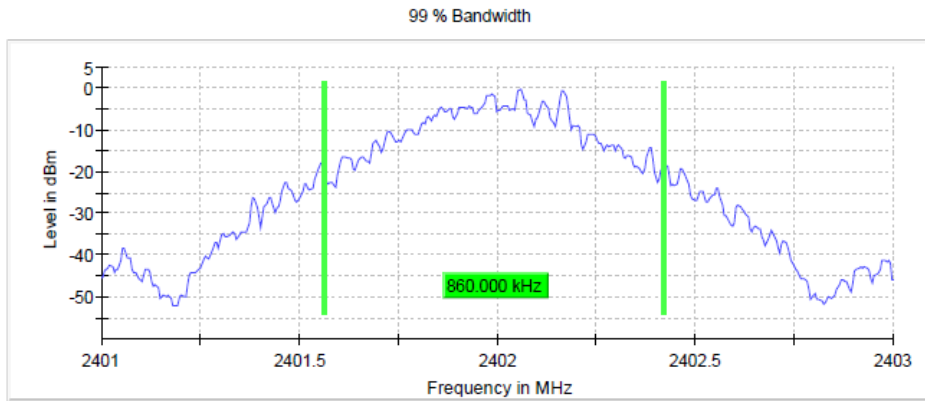

Measurement

Setting	Instrument Value
Start Frequency	2.40100 GHz
Stop Frequency	2.40300 GHz
Span	2.000 MHz
RBW	10.000 kHz
VBW	30.000 kHz
SweepPoints	400
Sweeptime	419.000 μ s
Reference Level	0.000 dBm
Attenuation	10.000 dB
Detector	MaxPeak
SweepCount	500
Filter	3 dB
Trace Mode	Max Hold
SweepType	FFT
Preamp	off
Stablemode	Trace
Stablevalue	0.30 dB
Run	5 / max. 150
Stable	3 / 3
Max Stable Difference	0.13 dB

Radio Technology = Bluetooth BDR, Operating Frequency = mid

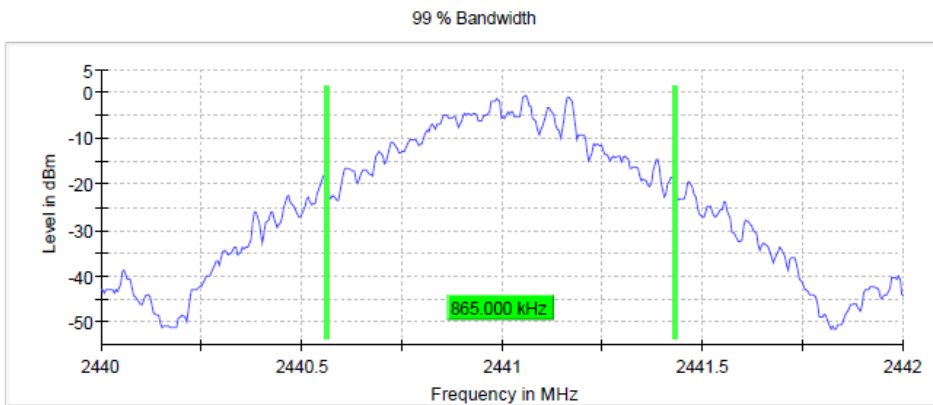

Measurement

Setting	Instrument Value
Start Frequency	2.44000 GHz
Stop Frequency	2.44200 GHz
Span	2.000 MHz
RBW	10.000 kHz
VBW	30.000 kHz
SweepPoints	400
Sweeptime	419.000 μ s
Reference Level	0.000 dBm
Attenuation	10.000 dB
Detector	MaxPeak
SweepCount	500
Filter	3 dB
Trace Mode	Max Hold
SweepType	FFT
Preamp	off
Stablemode	Trace
Stablevalue	0.30 dB
Run	11 / max. 150
Stable	3 / 3
Max Stable Difference	0.02 dB

Radio Technology = Bluetooth BDR, Operating Frequency = high

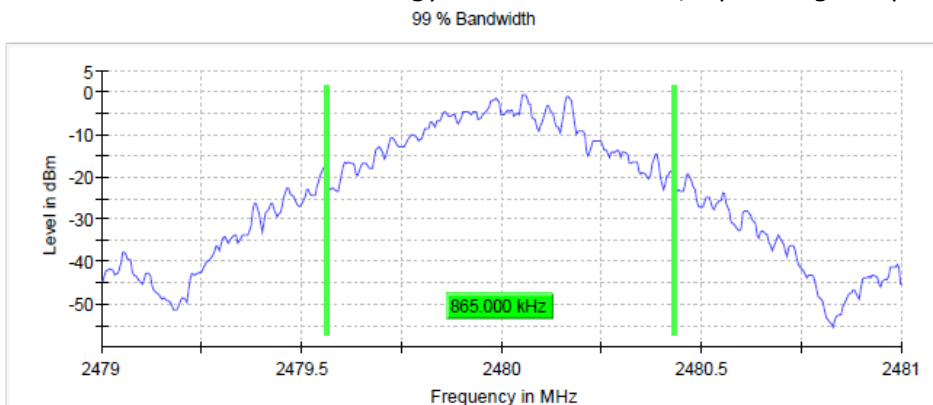

Measurement

Setting	Instrument Value
Start Frequency	2.47900 GHz
Stop Frequency	2.48100 GHz
Span	2.000 MHz
RBW	10.000 kHz
VBW	30.000 kHz
SweepPoints	400
Sweeptime	419.000 μ s
Reference Level	0.000 dBm
Attenuation	10.000 dB
Detector	MaxPeak
SweepCount	500
Filter	3 dB
Trace Mode	Max Hold
SweepType	FFT
Preamp	off
Stablemode	Trace
Stablevalue	0.30 dB
Run	5 / max. 150
Stable	3 / 3
Max Stable Difference	0.14 dB

5.3.5 TEST EQUIPMENT USED

- R&S TS8997

5.4 PEAK POWER OUTPUT

Standard **FCC Part 15 Subpart C**

The test was performed according to:

ANSI C63.10, chapter 11.9.1.3

5.4.1 TEST DESCRIPTION

FHSS EQUIPMENT:

The Equipment Under Test (EUT) was set up to perform the output power measurements. The results recorded were measured with the modulation which produces the worst-case (highest) output power. The reference level of the spectrum analyser was set higher than the output power of the EUT.

The EUT was connected to the test system as described in the block diagram below. The complete attenuation of the measurement path is known and considered.

Analyser settings:

- Resolution Bandwidth (RBW): ≥ 20 dB BW
- Video Bandwidth (VBW): ≥ 3 times RBW
- Trace: Maxhold
- Sweeps: Till stable (min. 300, max. 15000)
- Sweep time: Auto
- Detector: Peak

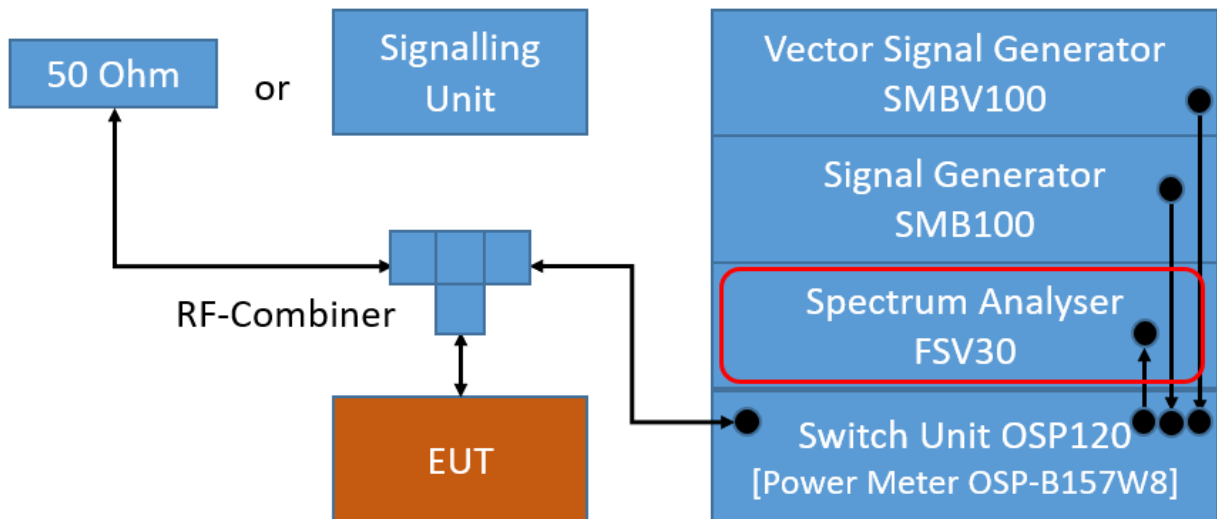

TS8997; Output Power

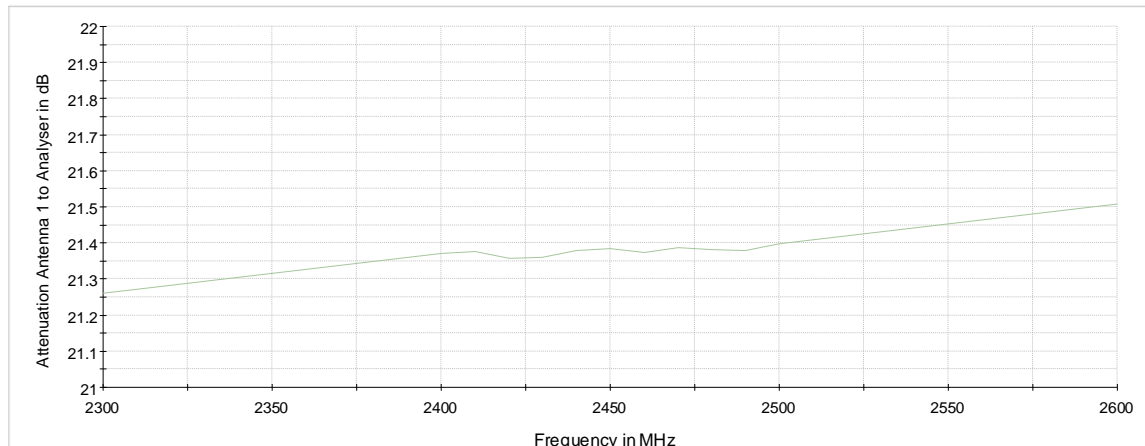

Attenuation Output power

5.4.2 TEST REQUIREMENTS / LIMITS

DTS devices:

FCC Part 15, Subpart C, §15.247 (b) (3)

For systems using digital modulation techniques in the 902-928 MHz, 2400-2483.5 MHz and 5725-5850 MHz bands: 1 watt.

==> Maximum conducted peak output power: 30 dBm (excluding antenna gain, if antennas with directional gains that do not exceed 6 dBi are used).

Frequency Hopping Systems:

FCC Part 15, Subpart C, §15.247 (b) (1)

For frequency hopping systems operating in the 2400-2483.5 MHz band employing at least 75 non-overlapping hopping channels, and all frequency hopping systems in the 5725-5850 MHz band: 1 watt. For all other frequency hopping systems in the 2400-2483.5 MHz band: 0.125 watts.

FCC Part 15, Subpart C, §15.247 (b) (2)

For frequency hopping systems operating in the 902-928 MHz band: 1 watt for systems employing at least 50 hopping channels; and, 0.25 watts for systems employing less than 50 hopping channels, but at least 25 hopping channels, as permitted under paragraph (a)(1)(i) of this section.

Used conversion factor: Limit (dBm) = 10 log (Limit (W)/1mW)

5.4.3 TEST PROTOCOL

Ambient temperature: 25 °C
 Air Pressure: 905 hPa
 Humidity: 40 %
 BT GFSK (1-DH5)

Band	Channel No.	Frequency [MHz]	Peak Power [dBm]	Limit [dBm]	Margin to Limit [dB]	E.I.R.P [dBm]
2.4 GHz ISM	0	2402	5,3	21,0	15,7	9,1
	39	2441	5,2	21,0	15,8	9,0
	78	2480	5,1	21,0	15,9	8,9

BT n/4 DQPSK (2-DH5)

Band	Channel No.	Frequency [MHz]	Peak Power [dBm]	Limit [dBm]	Margin to Limit [dB]	E.I.R.P [dBm]
2.4 GHz ISM	0	2402	4,5	21,0	16,5	8,3
	39	2441	4,4	21,0	16,6	8,2
	78	2480	4,3	21,0	16,7	8,1

BT 8-DPSK (3-DH5)

Band	Channel No.	Frequency [MHz]	Peak Power [dBm]	Limit [dBm]	Margin to Limit [dB]	E.I.R.P [dBm]
2.4 GHz ISM	0	2402	4,8	21,0	16,2	8,6
	39	2441	4,8	21,0	16,2	8,6
	78	2480	4,7	21,0	16,3	8,5

Remark: Please see next sub-clause for the measurement plot.

5.4.4 MEASUREMENT PLOT (EXAMPLE PLOT, SHOWING WORST CASE, IF APPLICABLE)

Radio Technology = Bluetooth BDR, Operating Frequency = low

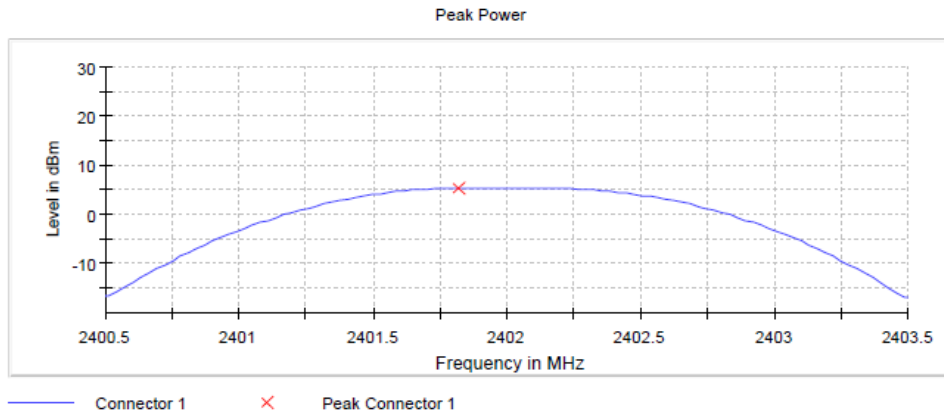

Measurement

Setting	Instrument Value
Start Frequency	2.40050 GHz
Stop Frequency	2.40350 GHz
Span	3.000 MHz
RBW	1.000 MHz
VBW	3.000 MHz
SweepPoints	101
SweepTime	4.210 μ s
Reference Level	10.000 dBm
Attenuation	20.000 dB
Detector	MaxPeak
SweepCount	100
Filter	3 dB
Trace Mode	Max Hold
SweepType	FFT
Preamp	off
Stablemode	Trace
Stablevalue	0.50 dB
Run	4 / max. 150
Stable	3 / 3
Max Stable Difference	0.02 dB

Radio Technology = Bluetooth BDR, Operating Frequency = mid

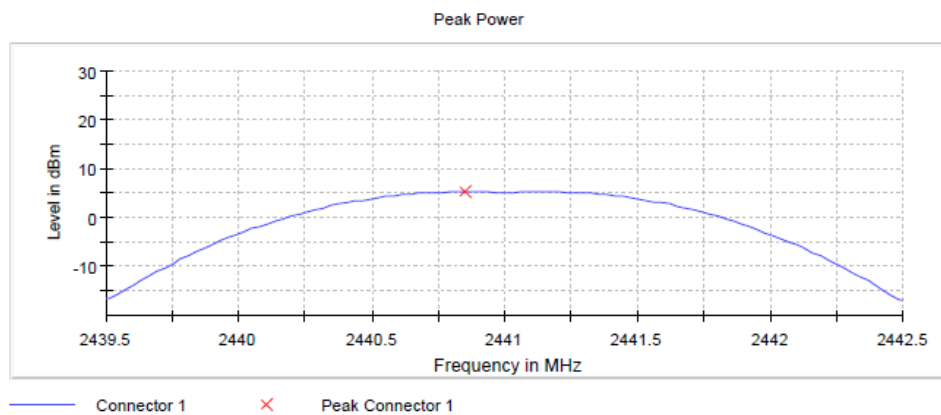

Measurement

Setting	Instrument Value
Start Frequency	2.43950 GHz
Stop Frequency	2.44250 GHz
Span	3.000 MHz
RBW	1.000 MHz
VBW	3.000 MHz
SweepPoints	101
SweepTime	4.210 μ s
Reference Level	10.000 dBm
Attenuation	20.000 dB
Detector	MaxPeak
SweepCount	100
Filter	3 dB
Trace Mode	Max Hold
SweepType	FFT
Preamp	off
Stablemode	Trace
Stablevalue	0.50 dB
Run	4 / max. 150
Stable	3 / 3
Max Stable Difference	0.07 dB

Radio Technology = Bluetooth BDR, Operating Frequency = high

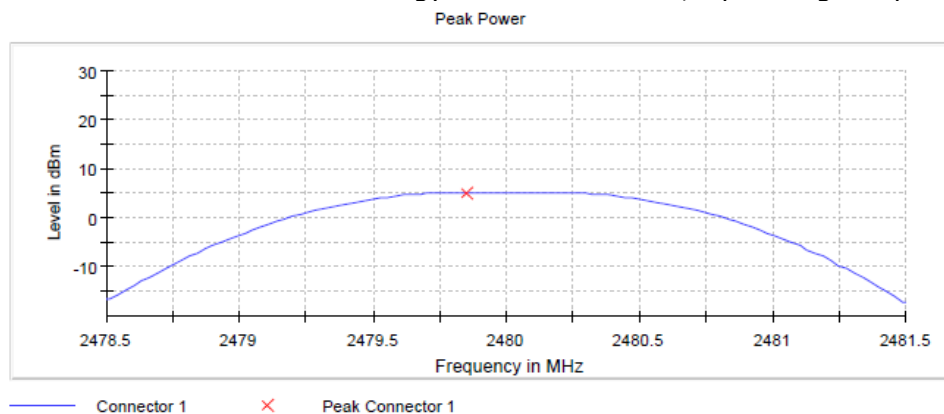

Measurement

Setting	Instrument Value
Start Frequency	2.47850 GHz
Stop Frequency	2.48150 GHz
Span	3.000 MHz
RBW	1.000 MHz
VBW	3.000 MHz
SweepPoints	101
SweepTime	4.210 μ s
Reference Level	10.000 dBm
Attenuation	20.000 dB
Detector	MaxPeak
SweepCount	100
Filter	3 dB
Trace Mode	Max Hold
SweepType	FFT
Preamp	off
Stablemode	Trace
Stablevalue	0.50 dB
Run	4 / max. 150
Stable	3 / 3
Max Stable Difference	0.01 dB

5.4.5 TEST EQUIPMENT USED

- R&S TS8997

5.5 SPURIOUS RF CONDUCTED EMISSIONS

Standard **FCC Part 15 Subpart C**

The test was performed according to:
ANSI C63.10, chapter 11.11

5.5.1 TEST DESCRIPTION

The Equipment Under Test (EUT) was set up to perform the spurious emissions measurements.

The EUT was connected to the test system as described in the block diagram below. The complete attenuation of the measurement path is known and considered.

Analyser settings:

- Frequency range: 30 – 26000 MHz
- Resolution Bandwidth (RBW): 100 kHz
- Video Bandwidth (VBW): 300 kHz
- Trace: Maxhold
- Sweeps: Till Stable (max. 120)
- Sweep Time: Auto
- Detector: Peak

The reference value for the measurement of the spurious RF conducted emissions is determined during the test "band edge compliance conducted". This value is used to calculate the 20 dBc or 30 dBc limit.

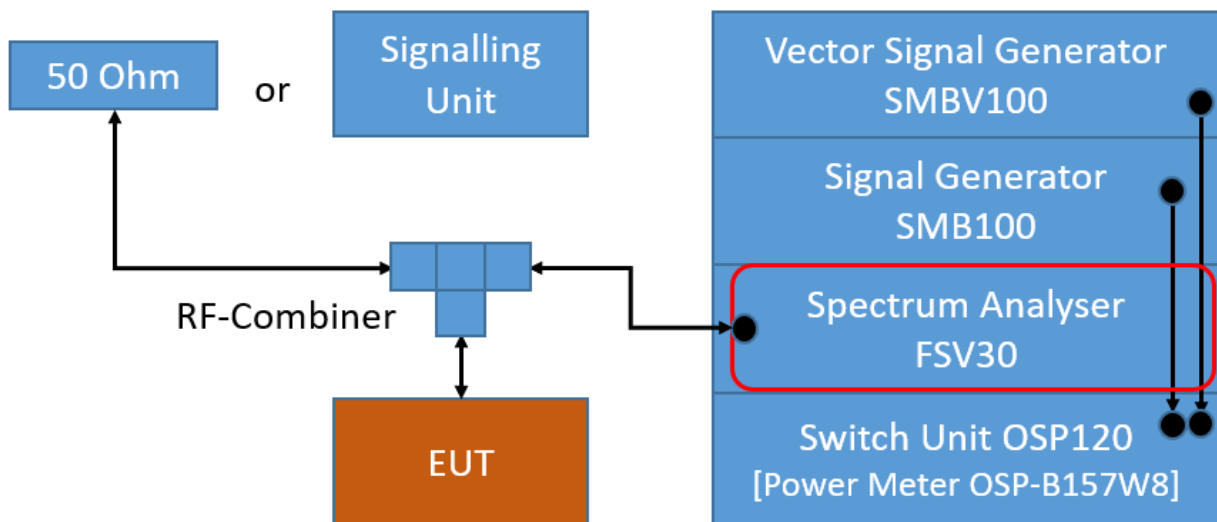

TS8997; Spurious RF Conducted Emissions

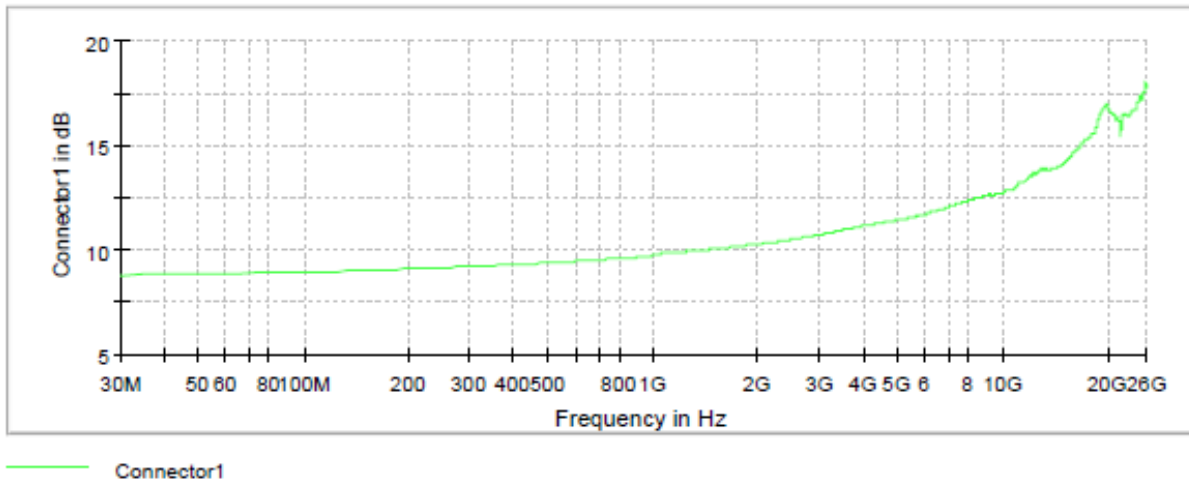

Attenuation of the measurement part

5.5.2 TEST REQUIREMENTS / LIMITS

FCC Part 15, Subpart C, §15.247 (c)

In any 100 kHz bandwidth outside the frequency band in which the spread spectrum intentional radiator is operating, the radio frequency power that is produced by the intentional radiator shall be at least 20 dB below that in the 100 kHz bandwidth within the band that contains the highest level of the desired power, based on either an RF conducted or a radiated measurement, provided the transmitter demonstrates compliance with the peak conducted power limits. If the transmitter complies with the conducted power limits based on the use of RMS averaging over a time interval, as permitted under paragraph (b)(3) of this section, the attenuation required under this paragraph shall be 30 dB instead of 20 dB.

5.5.3 TEST PROTOCOL

Ambient temperature: 25 °C
 Air Pressure: 900 hPa
 Humidity: 40 %
 BT GFSK (1-DH5)

Channel No	Channel Center Freq. [MHz]	Spurious Freq. [MHz]	Spurious Level [dBm]	Detector	RBW [kHz]	Ref. Level [dBm]	Limit [dBm]	Margin to Limit [dB]
0	2402	4807.2	-53.6	PEAK	100	5.3	-14.7	38.9
39	2441	4887.1	-54.0	PEAK	100	5.2	-14.8	39.2
78	2480	4957.1	-57.1	PEAK	100	5.1	-14.9	42.2

BT n/4 DQPSK (2-DH5)

Channel No	Channel Center Freq. [MHz]	Spurious Freq. [MHz]	Spurious Level [dBm]	Detector	RBW [kHz]	Ref. Level [dBm]	Limit [dBm]	Margin to Limit [dB]
0	2402	4807.2	-58.6	PEAK	100	4.5	-15.5	43.1
39	2441	4887.1	-59.1	PEAK	100	4.4	-15.6	43.5
78	2480	25525.3	-59.1	PEAK	100	4.3	-15.7	43.4

BT 8-DPSK (3-DH5)

Channel No	Channel Center Freq. [MHz]	Spurious Freq. [MHz]	Spurious Level [dBm]	Detector	RBW [kHz]	Ref. Level [dBm]	Limit [dBm]	Margin to Limit [dB]
0	2402	2395.0	-46.3	PEAK	100	4.8	-15.2	31.1
39	2441	4877.1	-59.8	PEAK	100	4.8	-15.2	44.6
78	2480	2488.5	-56.6	PEAK	100	4.7	-15.3	41.3

Remark: Please see next sub-clause for the measurement plot.

5.5.4 MEASUREMENT PLOT (EXAMPLE PLOT, SHOWING WORST CASE, IF APPLICABLE)

Radio Technology = Bluetooth BDR, Operating Frequency = low
Spurious

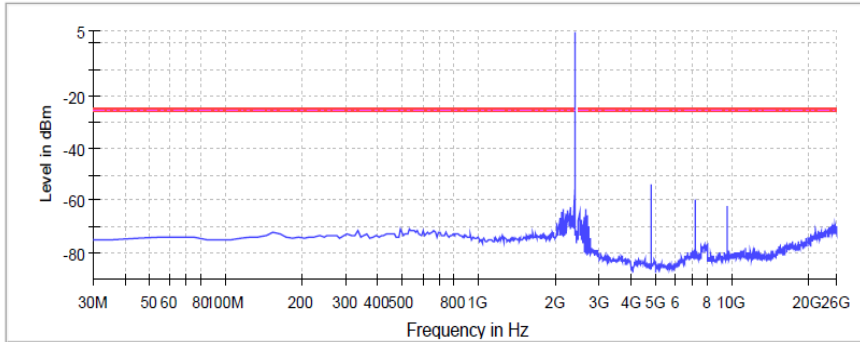

Frequency (MHz)	Level (dBm)	Margin (dB)	Limit (dBm)
4807.166065	-53.6	28.0	-25.5
2395.021008	-55.4	29.9	-25.5
7205.789099	-59.6	34.1	-25.5
9604.412133	-62.2	36.7	-25.5
2295.441176	-62.9	37.4	-25.5
2165.987395	-63.1	37.6	-25.5
2638.411071	-63.1	37.6	-25.5
2305.399160	-64.1	38.6	-25.5
2255.609244	-64.2	38.6	-25.5
2126.155462	-64.3	38.8	-25.5
2498.491394	-64.4	38.9	-25.5
2205.819328	-64.9	39.4	-25.5
2678.388122	-65.5	39.9	-25.5
2335.273109	-65.7	40.1	-25.5
2275.525210	-65.7	40.2	-25.5

— Limit — Sum Level - - - Threshold × Critical × Final Critical

Radio Technology = Bluetooth EDR 2, Operating Frequency = mid
Spurious

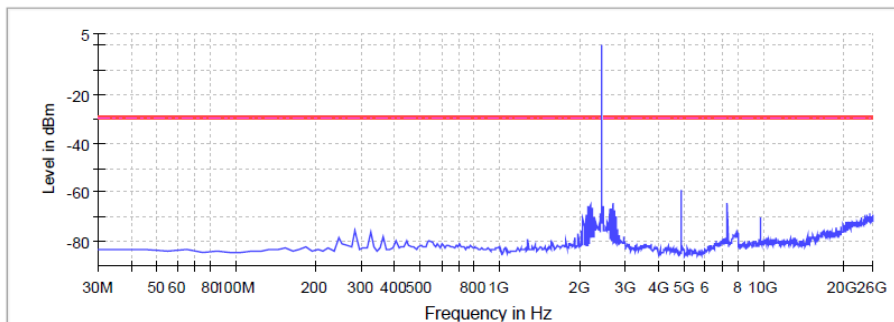

Frequency (MHz)	Level (dBm)	Margin (dB)	Limit (dBm)
4887.120166	-59.1	29.5	-29.6
4877.125903	-62.3	32.7	-29.6
2678.388122	-64.5	34.8	-29.6
7325.720251	-64.6	35.0	-29.6
2205.819328	-65.2	35.6	-29.6
2156.029412	-65.5	35.8	-29.6
2245.651261	-66.0	36.4	-29.6
2195.861345	-66.1	36.4	-29.6
2638.411071	-66.9	37.2	-29.6
2598.434020	-67.0	37.3	-29.6
2718.365172	-67.5	37.8	-29.6
2165.987395	-67.8	38.1	-29.6
25435.324161	-68.8	39.1	-29.6
25885.065980	-69.3	39.6	-29.6
24645.777412	-69.4	39.7	-29.6

— Limit — Sum Level - - - Threshold × Critical × Final Critical

Radio Technology = Bluetooth EDR 3, Operating Frequency = high
Spurious

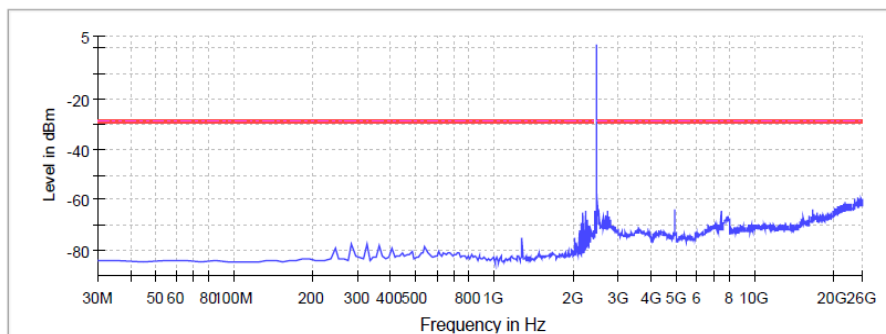

Frequency (MHz)	Level (dBm)	Margin (dB)	Limit (dBm)
2488.497131	-56.6	27.9	-28.7
24785.697089	-59.1	30.4	-28.7
25755.140565	-59.4	30.7	-28.7
25635.209414	-59.7	31.0	-28.7
25385.352847	-59.7	31.0	-28.7
24375.932320	-59.8	31.1	-28.7
25965.020081	-59.9	31.2	-28.7
24345.949533	-60.0	31.3	-28.7
25815.106141	-60.0	31.3	-28.7
25285.410221	-60.1	31.4	-28.7
24975.588079	-60.1	31.4	-28.7
25695.174989	-60.2	31.5	-28.7
25705.169252	-60.3	31.5	-28.7
24385.926583	-60.3	31.6	-28.7
25035.553655	-60.4	31.7	-28.7

— Limit — Sum Level - - - Threshold × Critical × Final Critical

5.5.5 TEST EQUIPMENT USED

- R&S TS8997

5.6 TRANSMITTER SPURIOUS RADIATED EMISSIONS

Standard **FCC Part 15 Subpart C**

The test was performed according to:

ANSI C63.10, chapter 6.4, 6.5, 6.6.5

5.6.1 TEST DESCRIPTION

The test set-up was made in accordance to the general provisions of ANSI C63.10 in a typical installation configuration. The measurements were performed according the following sub-chapters of ANSI C63.10:

- < 30 MHz: Chapter 6.4
- 30 MHz – 1 GHz: Chapter 6.5
- > 1 GHz: Chapter 6.6 (procedure according 6.6.5 used)

The measurement procedure is implemented into the EMI test software EMC32 from R&S. Exploratory tests are performed at 3 orthogonal axes to determine the worst-case orientation of a body-worn or handheld EUT. The final test on all kind of EUTs is also performed at 3 axes. A pre-check is performed while the EUT is powered.

Below 1 GHz:

The Equipment Under Test (EUT) was set up on a non-conductive table in the semi-anechoic chamber. The influence of the EUT support table that is used between 30–1000 MHz was evaluated.

1. Measurement up to 30 MHz

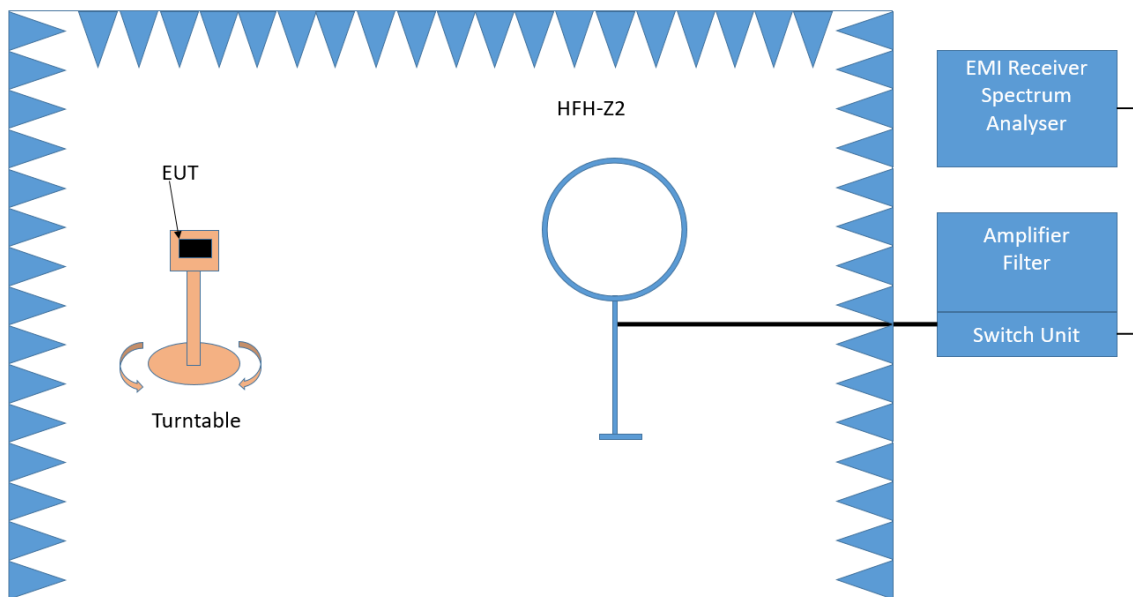

Test Setup; Spurious Emission Radiated (SAC), 9 kHz – 30 MHz

The Loop antenna HFH2-Z2 is used.

Step 1: pre measurement

- Anechoic chamber
- Antenna distance: 3 m
- Antenna height: 1 m
- Detector: Peak-Maxhold
- Frequency range: 0.009 - 0.15 MHz and 0.15 - 30 MHz
- Frequency steps: 0.05 kHz and 2.25 kHz
- IF-Bandwidth: 0.2 kHz and 9 kHz
- Measuring time / Frequency step: 100 ms (FFT-based)

Intention of this step is, to determine the radiated EMI-profile of the EUT. Afterwards the relevant emissions for the final measurement are identified.

Step 2: final measurement

For the relevant emissions determined in step 1, an additional measurement with the following settings will be performed. Intention of this step is to find the maximum emission level.

- Detector: Quasi-Peak (9 kHz - 150 kHz, Peak / Average 150 kHz- 30 MHz)
- Frequency range: 0.009 - 30 MHz
- Frequency steps: measurement at frequencies detected in step 1
- IF-Bandwidth: 0.2 - 10 kHz
- Measuring time / Frequency step: 1 s

2. Measurement above 30 MHz and up to 1 GHz

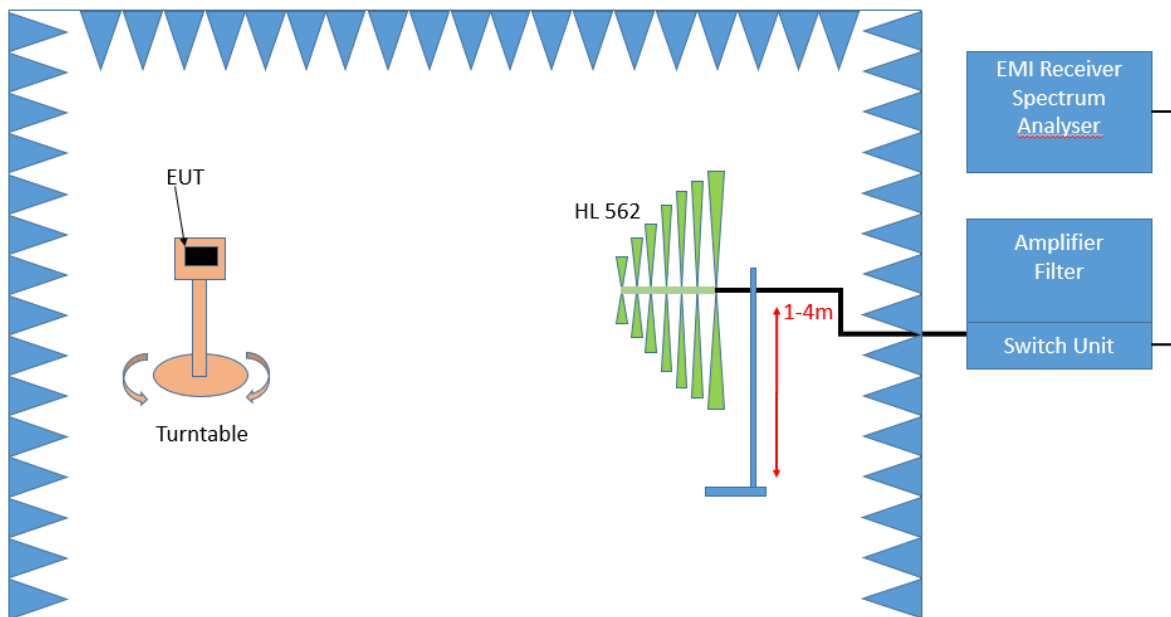

Test Setup; Spurious Emission Radiated (SAC), 30 MHz- 1GHz

Step 1: Preliminary scan

This is a preliminary test to identify the highest amplitudes relative to the limit.

Settings for step 1:

- Antenna distance: 3 m
- Detector: Peak-Maxhold / Quasipeak (FFT-based)
- Frequency range: 30 - 1000 MHz
- Frequency steps: 30 kHz
- IF-Bandwidth: 120 kHz
- Measuring time / Frequency step: 100 ms
- Turntable angle range: -180° to 90°
- Turntable step size: 90°

- Height variation range: 1 – 4 m
- Height variation step size: 1.5 m
- Polarisation: Horizontal + Vertical

Intention of this step is, to determine the radiated EMI-profile of the EUT. Afterwards the relevant emissions for the final measurement are identified.

Step 2: Adjustment measurement

In this step the accuracy of the turntable azimuth and antenna height will be improved. This is necessary to find out the maximum value of every frequency.

For each frequency, which was determined the turntable azimuth and antenna height will be adjusted. The turntable azimuth will slowly vary by 360°. During this action, the value of emission is continuously measured. The turntable azimuth at the highest emission will be recorded and adjusted. In this position, the antenna height will also slowly vary between 1 – 4 meter. During this action, the value of emission is also continuously measured. The antenna height of the highest emission will also be recorded and adjusted.

- Detector: Peak – Maxhold
- Measured frequencies: in step 1 determined frequencies
- IF – Bandwidth: 120 kHz
- Measuring time: 100 ms
- Turntable angle range: 360 °
- Height variation range: 1 – 4 m
- Antenna Polarisation: max. value determined in step 1

Step 3: Final measurement with QP detector

With the settings determined in step 2, the final measurement will be performed:

EMI receiver settings for step 3:

- Detector: Quasi-Peak (< 1 GHz)
- Measured frequencies: in step 1 determined frequencies
- IF – Bandwidth: 120 kHz
- Measuring time: 1 s

After the measurement a plot will be generated which contains a diagram with the results of the preliminary scan and a chart with the frequencies and values of the results of the final measurement.

Above 1 GHz:

The Equipment Under Test (EUT) was set up on a non-conductive support (tilt device) at 1.5 m height in the fully-anechoic chamber.

All steps were performed with one height (1.5 m) of the receiving antenna only.

3. Measurement above 1 GHz

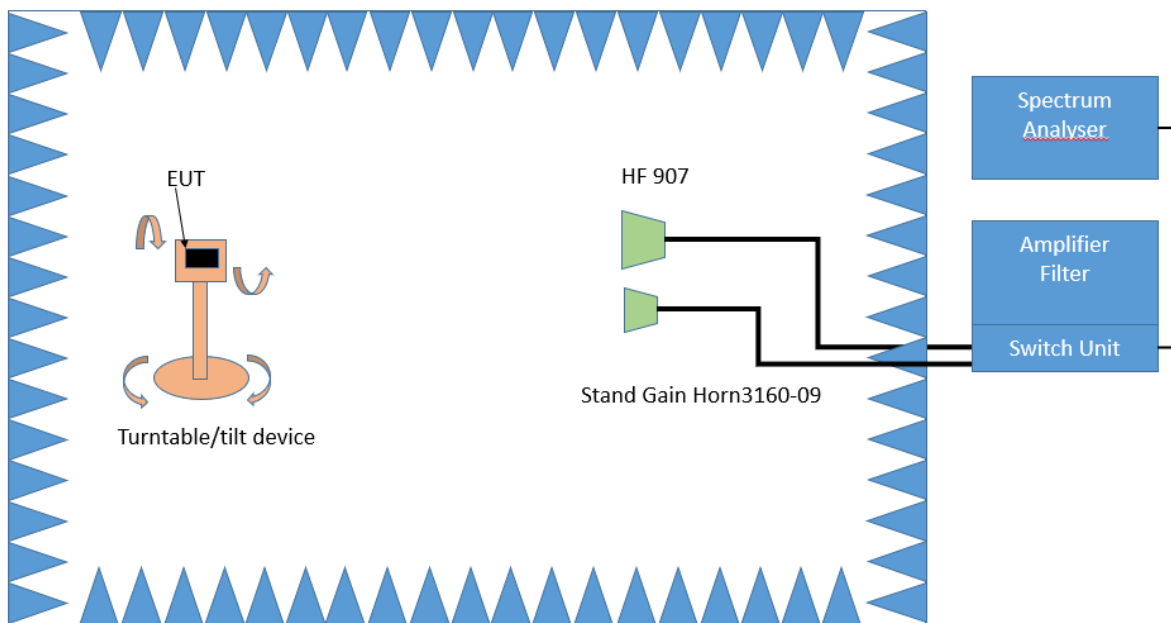

Test Setup; Spurious Emission Radiated (FAC), 1 GHz-26.5 GHz

Step 1:

The EUT is turned during the preliminary measurement across the elevation axis, with a step size of 90° .

The turn table step size (azimuth angle) for the preliminary measurement is 45° .

Spectrum analyser settings:

- Detector: Peak, Average
- RBW = 1 MHz
- VBW = 3 MHz

Step 2:

The turn table azimuth will slowly vary by $\pm 22.5^\circ$.

The elevation angle will slowly vary by $\pm 45^\circ$

Spectrum analyser settings:

- Detector: Peak

Step 3:

Spectrum analyser settings for step 3:

- Detector: Peak / CISPR Average
- Measured frequencies: in step 1 determined frequencies
- RBW = 1 MHz
- VBW = 3 MHz
- Measuring time: 1 s

5.6.2 TEST REQUIREMENTS / LIMITS

FCC Part 15, Subpart C, §15.247 (d)

... In addition, radiated emissions which fall in the restricted bands, as defined in Section 15.205(a), must also comply with the radiated emission limits specified in Section 15.209(a) (see Section 15.205(c)).

FCC Part 15, Subpart C, §15.209, Radiated Emission Limits

Frequency in MHz	Limit ($\mu\text{V}/\text{m}$)	Measurement distance (m)	Limits ($\text{dB}\mu\text{V}/\text{m}$)
0.009 – 0.49	2400/F(kHz)@300m	3	(48.5 – 13.8)@300m
0.49 – 1.705	24000/F(kHz)@30m	3	(33.8 – 23.0)@30m
1.705 – 30	30@30m	3	29.5@30m

The measured values are corrected with an inverse linear distance extrapolation factor (40 dB/decade) according FCC 15.31 (2).

Frequency in MHz	Limit ($\mu\text{V}/\text{m}$)	Measurement distance (m)	Limits ($\text{dB}\mu\text{V}/\text{m}$)
30 – 88	100@3m	3	40.0@3m
88 – 216	150@3m	3	43.5@3m
216 – 960	200@3m	3	46.0@3m
960 - 26000	500@3m	3	54.0@3m
26000 - 40000	500@3m	1	54.0@3m

The measured values above 26 GHz are corrected with an inverse linear distance extrapolation factor (20 dB/decade).

§15.35(b) ..., there is also a limit on the radio frequency emissions, as measured using instrumentation with a peak detector function, corresponding to 20 dB above the maximum permitted average limit....

Used conversion factor: $\text{Limit (dB}\mu\text{V}/\text{m)} = 20 \log (\text{Limit } (\mu\text{V}/\text{m})/1\mu\text{V}/\text{m})$

5.6.3 TEST PROTOCOL

Ambient temperature: 23-25 °C
 Air Pressure: 1002-1014 hPa
 Humidity: 38-45 %
 BT GFSK (1-DH5)
 Applied duty cycle correction (AV): 0 dB

Ch. No.	Ch. Center Freq. [MHz]	Spurious Freq. [MHz]	Spurious Level [dBµV/m]	Detector	RBW [kHz]	Limit [dBµV/m]	Margin to Limit [dB]	Limit Type
0	2402	4803,7	51,7	PEAK	1000	74,0	22,3	RB
0	2402	4803,7	42,4	AV	1000	54,0	11,6	RB
0	2402	4803,9	44,7	AV	1000	54,0	9,3	RB
0	2402	4803,9	52,4	PEAK	1000	74,0	21,6	RB
0	2402	14485,9	52,6	PEAK	1000	74,0	21,4	RB
0	2402	14485,9	39,8	AV	1000	54,0	14,2	RB
0	2402	14499,1	39,3	AV	1000	54,0	14,7	RB
0	2402	14499,1	52,4	PEAK	1000	74,0	21,6	RB
0	2402	15533,6	53,5	PEAK	1000	74,0	20,5	RB
0	2402	15533,6	40,2	AV	1000	54,0	13,8	RB
0	2402	15539,7	53,2	PEAK	1000	74,0	20,8	RB
0	2402	15539,7	40,3	AV	1000	54,0	13,7	RB
39	2441	4882,0	52,8	PEAK	1000	74,0	21,2	RB
39	2441	4882,0	45,2	AV	1000	54,0	8,8	RB
39	2441	15541,4	40,4	AV	1000	54,0	13,6	RB
39	2441	15541,4	53,0	PEAK	1000	74,0	21,0	RB
78	2480	---	-	---	1000	---	-	RB

BT n/4 DQPSK (2-DH5)
 Applied duty cycle correction (AV): 0 dB

Ch. No.	Ch. Center Freq. [MHz]	Spurious Freq. [MHz]	Spurious Level [dBµV/m]	Detector	RBW [kHz]	Limit [dBµV/m]	Margin to Limit [dB]	Limit Type
0	2402	-	-	---	1000	---	-	RB
39	2441	-	-	---	1000	---	-	RB
78	2480	-	-	---	1000	---	-	RB

Remark: Please see next sub-clause for the measurement plot.

5.6.4 MEASUREMENT PLOT (EXAMPLE PLOT, SHOWING WORST CASE, IF APPLICABLE)

Radio Technology = Bluetooth BDR, Operating Frequency = mid,
Measurement range = 9 kHz - 30 MHz

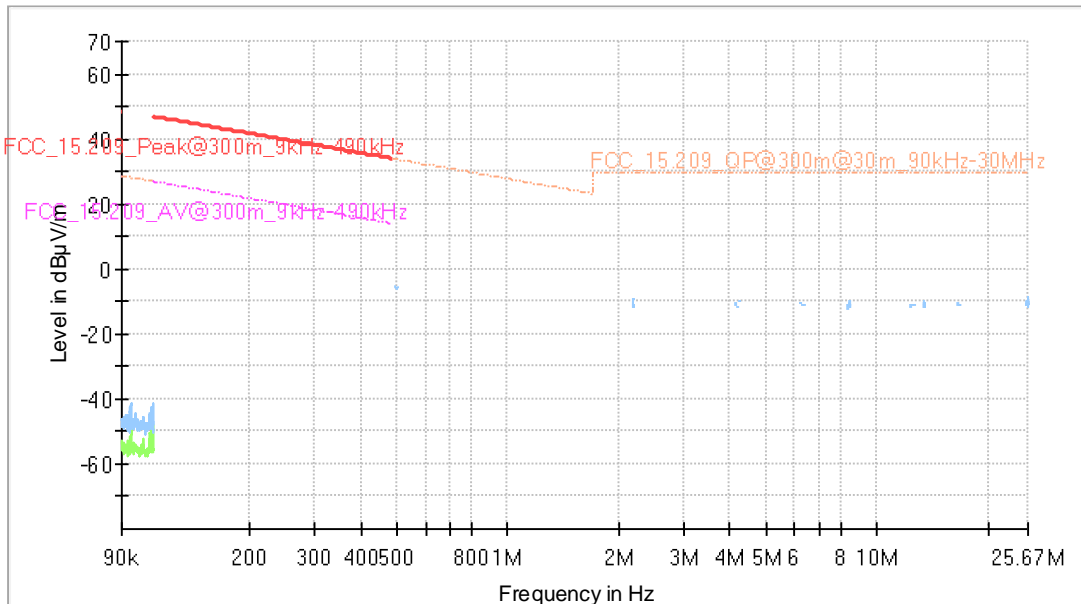

Radio Technology = Bluetooth BDR, Operating Frequency = low,
Measurement range = 30 MHz - 1 GHz

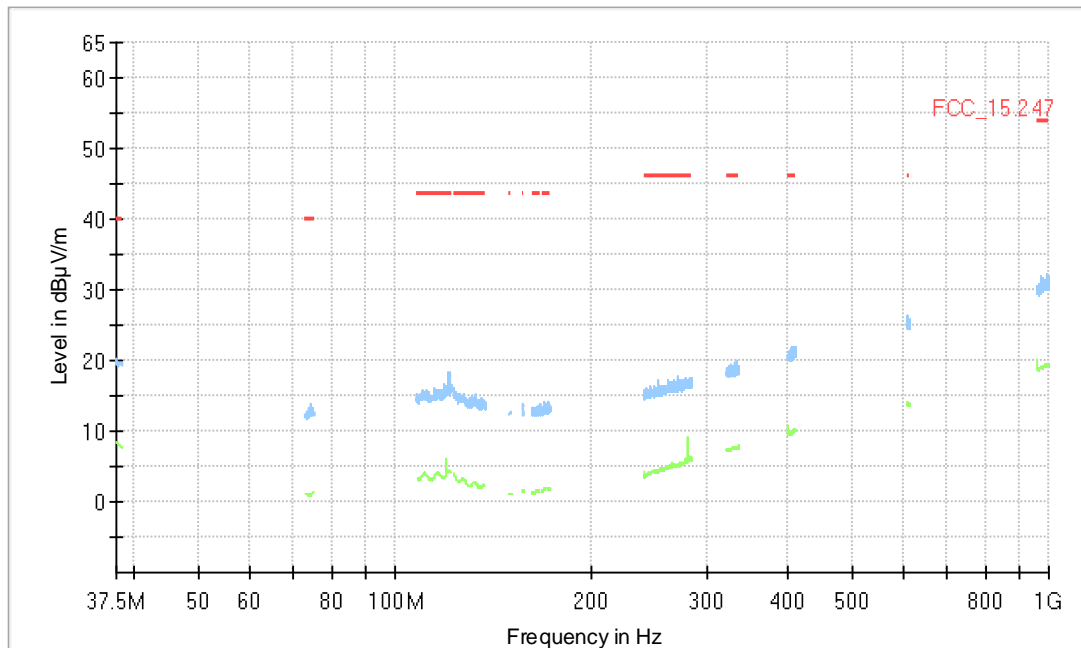

Radio Technology = Bluetooth BDR, Operating Frequency = mid,
Measurement range = 30 MHz - 1 GHz

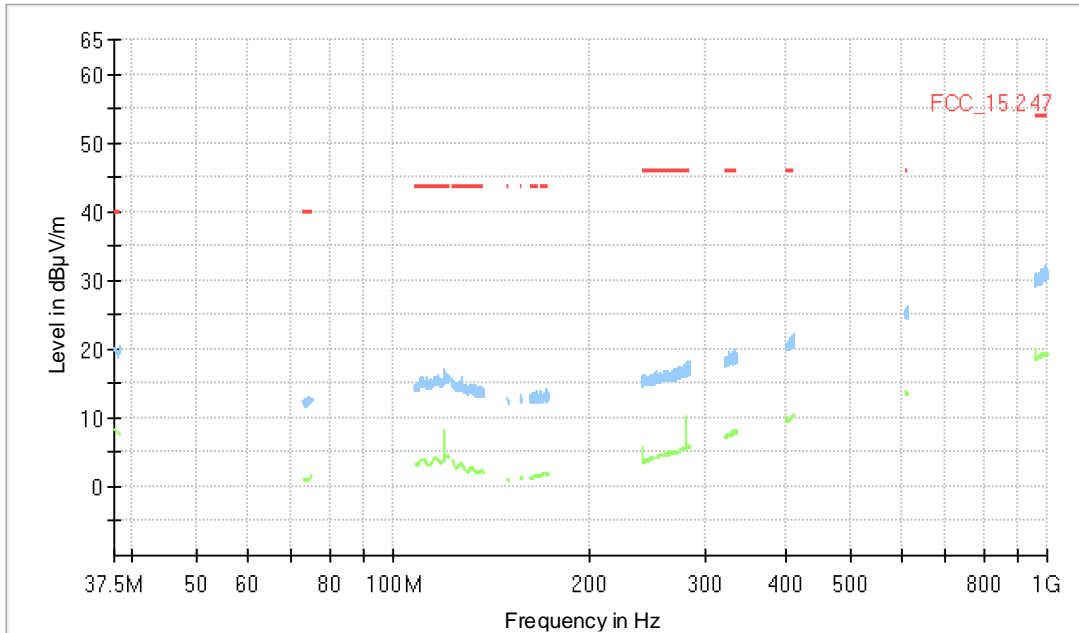

Radio Technology = Bluetooth BDR, Operating Frequency = high,
Measurement range = 30 MHz - 1 GHz

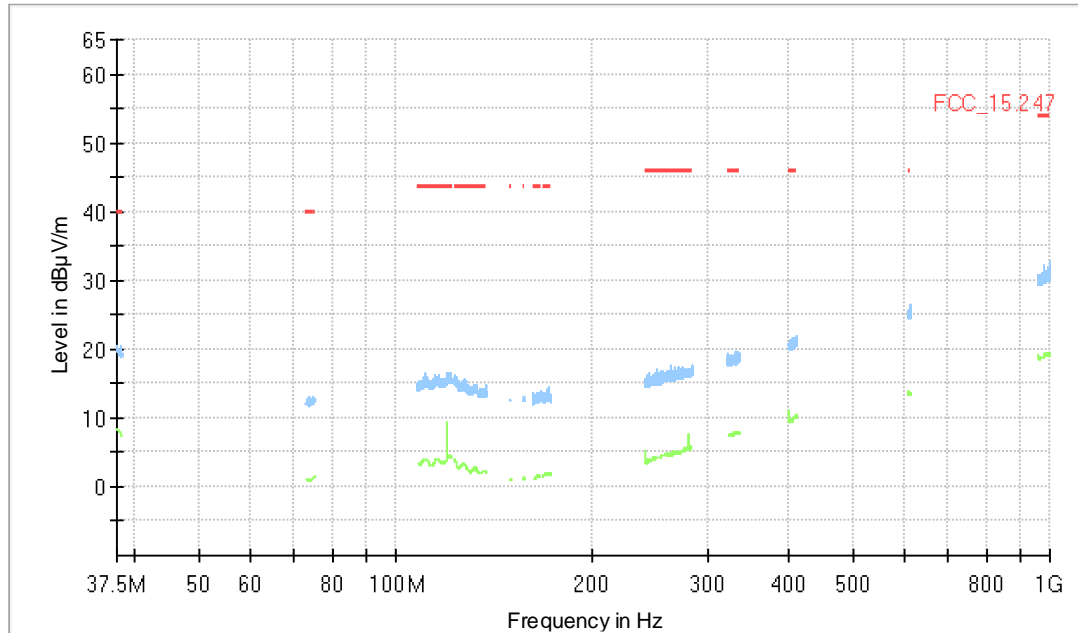

Radio Technology = Bluetooth BDR, Operating Frequency = low,
Measurement range = 1 GHz - 26 GHz

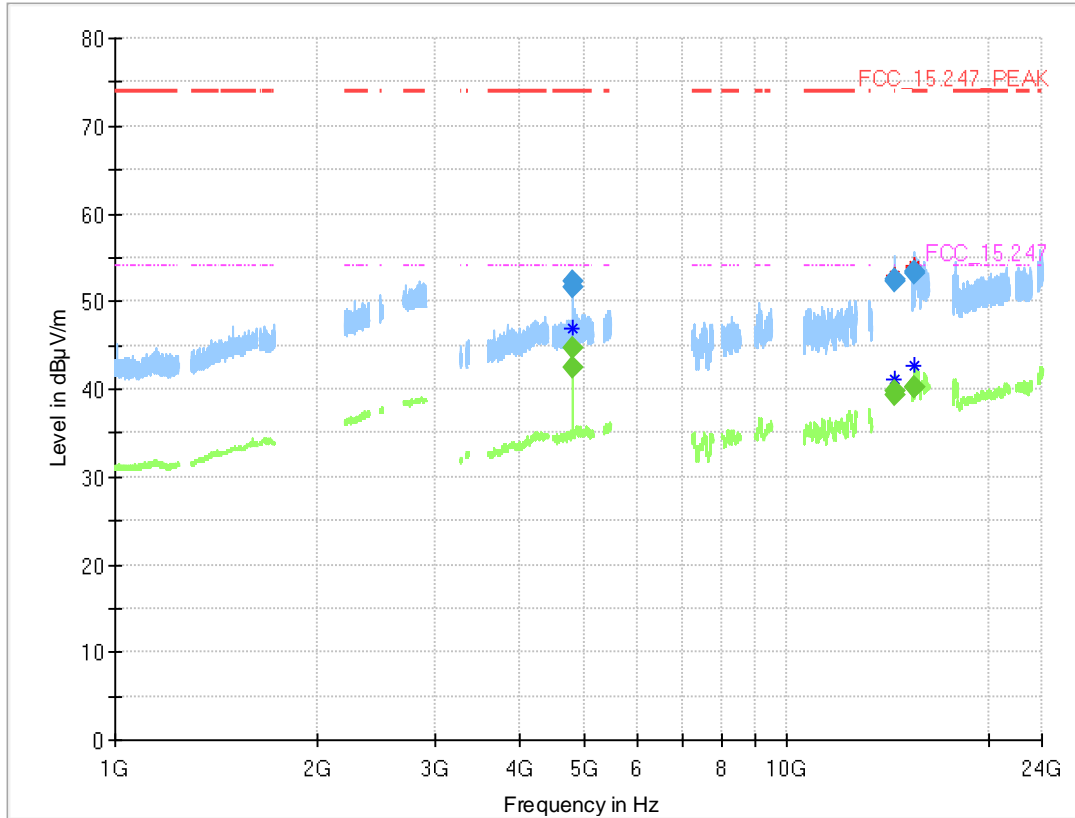

Final Result

Frequency (MHz)	MaxPeak (dBµV/m)	CAverage (dBµV/m)	Limit (dBµV/m)	Margin (dB)	Meas. Time (ms)	Bandwidth (kHz)	Height (cm)	Pol	Azimuth (deg)	Elevation (deg)	Corr. (dB/m)
4803.713	51.7	---	74.00	22.30	1000.0	1000.000	150.0	H	33.0	86.0	4.9
4803.713	---	42.4	54.00	11.63	1000.0	1000.000	150.0	H	33.0	86.0	4.9
4803.875	---	44.7	54.00	9.33	1000.0	1000.000	150.0	H	-55.0	105.0	4.8
4803.875	52.4	---	74.00	21.61	1000.0	1000.000	150.0	H	-55.0	105.0	4.8
14485.900	52.6	---	74.00	21.41	1000.0	1000.000	150.0	V	-96.0	15.0	-3.3
14485.900	---	39.8	54.00	14.24	1000.0	1000.000	150.0	V	-96.0	15.0	-3.3
14499.100	---	39.3	54.00	14.69	1000.0	1000.000	150.0	V	-83.0	15.0	-3.6
14499.100	52.4	---	74.00	21.63	1000.0	1000.000	150.0	V	-83.0	15.0	-3.6
15533.600	53.5	---	74.00	20.54	1000.0	1000.000	150.0	H	-148.0	30.0	-1.8
15533.600	---	40.2	54.00	13.83	1000.0	1000.000	150.0	H	-148.0	30.0	-1.8
15539.692	53.2	---	74.00	20.77	1000.0	1000.000	150.0	V	-53.0	1.0	-1.7
15539.692	---	40.3	54.00	13.71	1000.0	1000.000	150.0	V	-53.0	1.0	-1.7

Radio Technology = Bluetooth BDR, Operating Frequency = high,
Measurement range = 1 GHz - 26 GHz

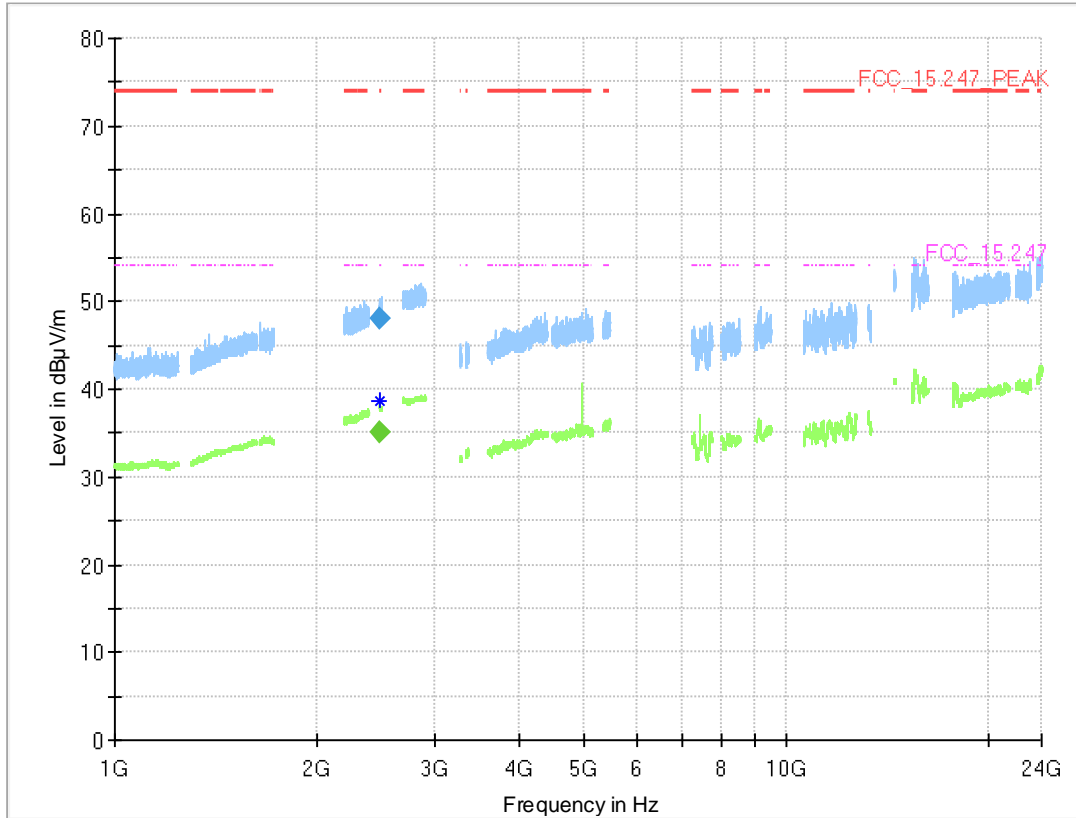

Final Result

Frequency (MHz)	MaxPeak (dBµV/m)	CAverage (dBµV/m)	Limit (dBµV/m)	Margin (dB)	Meas. Time (ms)	Bandwidth (kHz)	Height (cm)	Pol	Azimuth (deg)	Elevation (deg)	Corr. (dB/m)
2483.665	---	35.0	54.00	18.98	1000.0	1000.000	150.0	V	-79.0	96.0	5.3
2483.665	48.1	---	74.00	25.94	1000.0	1000.000	150.0	V	-79.0	96.0	5.3

Radio Technology = Bluetooth BDR, Operating Frequency = mid,
Measurement range = 1 GHz - 26 GHz

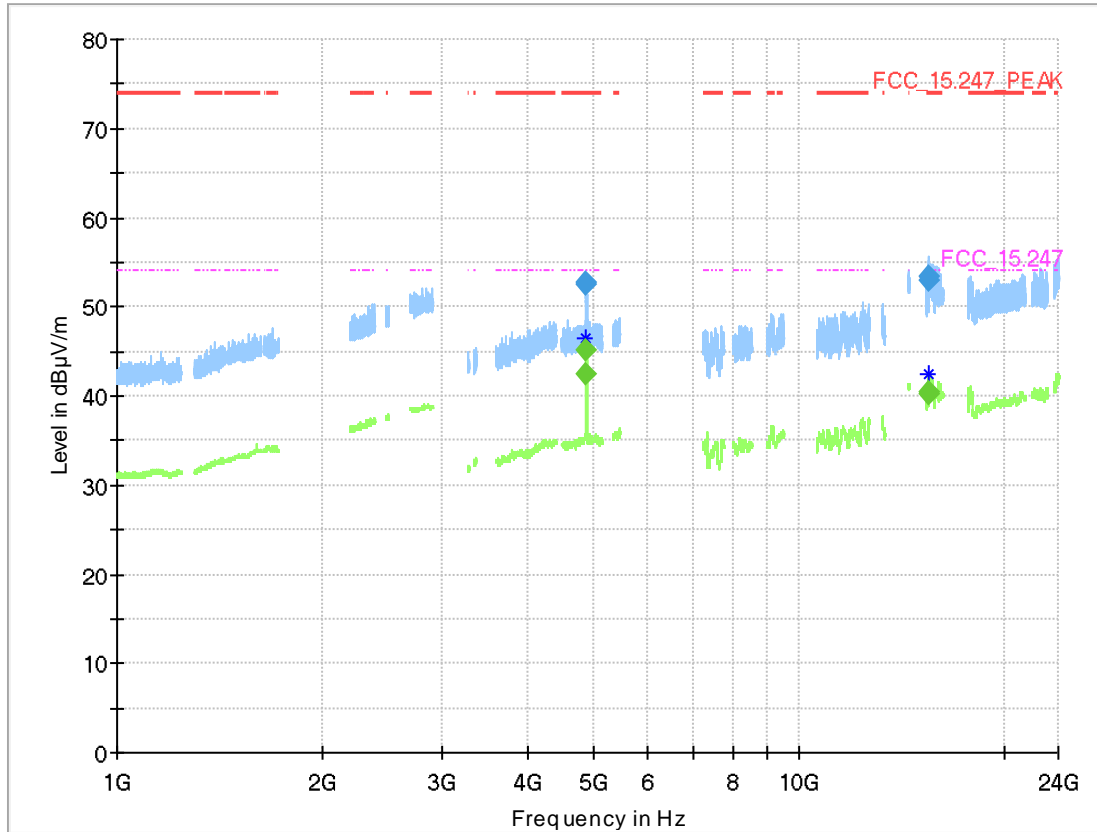

Final_Result

Frequency (MHz)	MaxPeak (dBµV/m)	CAverage (dBµV/m)	Limit (dBµV/m)	Margi n (dB)	Meas. Time (ms)	Bandwidt h (kHz)	Heigh t (cm)	Pol	Azimet h (deg)	Elevatio n (deg)	Corr. (dB/m)
4882.038	52.8	---	74.00	21.19	1000.0	1000.000	150.0	H	-55.0	102.0	4.5
4882.038	---	45.2	54.00	8.82	1000.0	1000.000	150.0	H	-55.0	102.0	4.5
4882.363	52.5	---	74.00	21.49	1000.0	1000.000	150.0	H	-57.0	105.0	4.5
4882.363	---	42.5	54.00	11.53	1000.0	1000.000	150.0	H	-57.0	105.0	4.5
15539.267	53.5	---	74.00	20.46	1000.0	1000.000	150.0	V	-88.0	15.0	-1.7
15539.267	---	40.3	54.00	13.66	1000.0	1000.000	150.0	V	-88.0	15.0	-1.7
15541.392	53.0	---	74.00	20.99	1000.0	1000.000	150.0	H	150.0	78.0	-1.7
15541.392	---	40.4	54.00	13.65	1000.0	1000.000	150.0	H	150.0	78.0	-1.7

5.6.5 TEST EQUIPMENT USED

- Radiated Emissions FAR 2.4 GHz FCC
- Radiated Emissions SAC H-Field
- Radiated Emissions SAC up to 1 GHz

5.7 BAND EDGE COMPLIANCE CONDUCTED

Standard **FCC Part 15 Subpart C**

The test was performed according to:

ANSI C63.10, chapter 11.11

5.7.1 TEST DESCRIPTION

For the conducted measurement, the Equipment Under Test (EUT) is placed in a shielded room. The reference power was measured in the test case "Spurious RF Conducted Emissions".

The EUT was connected to the test system as described in the block diagram below. The complete attenuation of the measurement path is known and considered.

Analyser settings:

- Lower Band Edge:
Measured range: 2310.0 MHz to 2483.5 MHz
Upper Band Edge
Measured range: 2400.0 MHz to 2500 MHz
- Detector: Peak
- Resolution Bandwidth (RBW): 100 kHz
- Video Bandwidth (VBW): 300 kHz
- Sweptime: Auto
- Sweeps: Till stable (min. 300, max. 15000)
- Trace: Maxhold

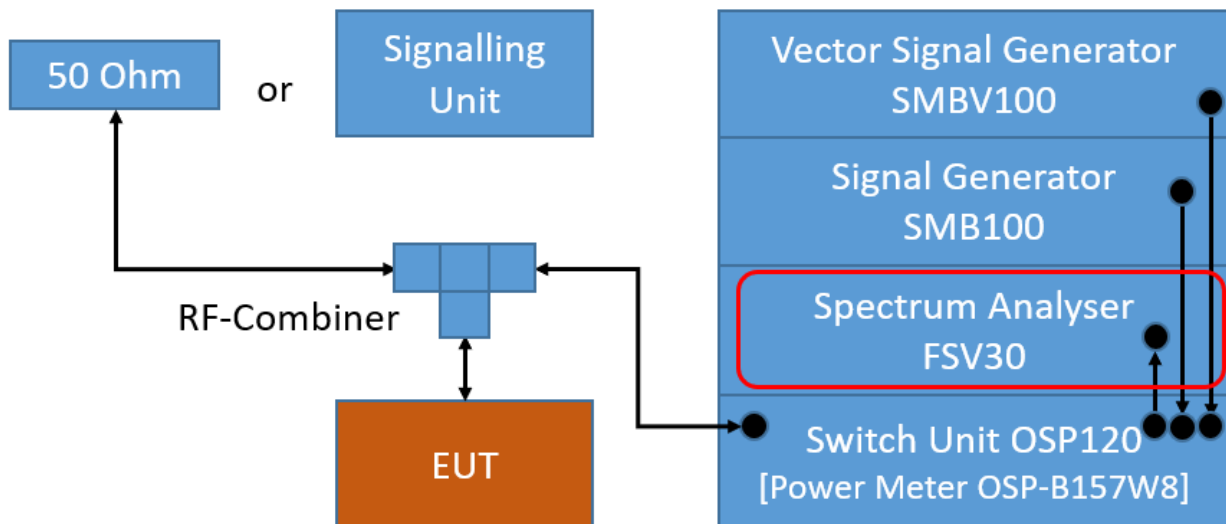

TS8997; Band Edge Conducted

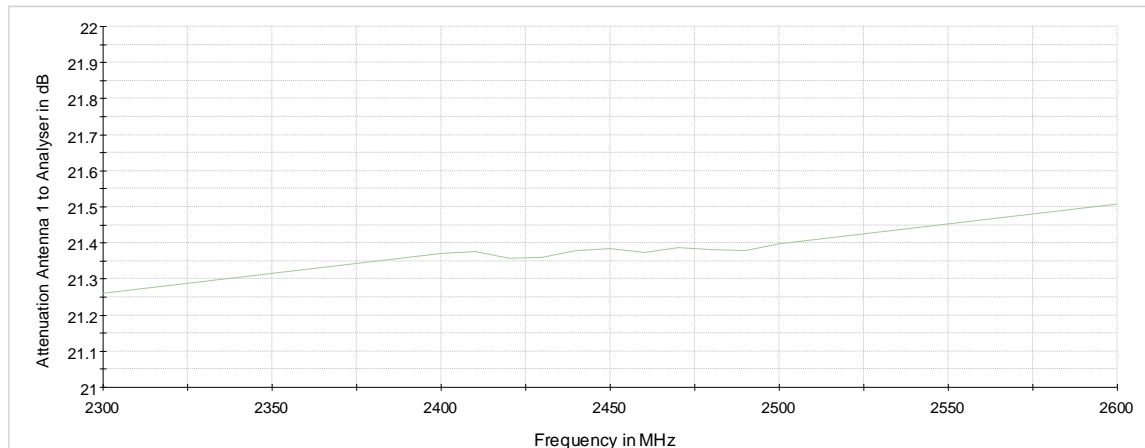

Attenuation of the measurement path

5.7.2 TEST REQUIREMENTS / LIMITS

FCC Part 15.247 (d)

“In any 100 kHz bandwidth outside the frequency band in which the spread spectrum or digitally modulated intentional radiator is operating, the radio frequency power that is produced by the intentional radiator shall be at least 20 dB below that in the 100 kHz bandwidth within the band that contains the highest level of the desired power, based on either an RF conducted or a radiated measurement, provided the transmitter demonstrates compliance with the peak conducted power limits. ...

If the transmitter complies with the conducted power limits based on the use of RMS averaging over a time interval, as permitted under paragraph (b)(3) of this section, the attenuation required under this paragraph shall be 30 dB instead of 20 dB. Attenuation below the general limits specified in Section 15.209(a) is not required. In addition, radiated emissions which fall in the restricted bands, as defined in Section 15.205(a), must also comply with the radiated emission limits specified in Section 15.209(a) (see Section 15.205(c)).”

For the conducted measurement the RF power at the band edge shall be “at least 20 dB below that in the 100 kHz bandwidth within the band that contains the highest level of the desired power...”

5.7.3 TEST PROTOCOL

Ambient temperature: 25 °C
 Air Pressure: 905 hPa
 Humidity: 40 %
 BT GFSK (1-DH5)

Channel No.	Channel Center Frequency [MHz]	Band Edge Freq. [MHz]	Spurious Level [dBm]	Detector	RBW [kHz]	Ref. Level [dBm]	Limit [dBm]	Margin to Limit [dB]
0	2402	2400,0	-51,9	PEAK	100	5,1	-14,9	37,0
78	2480	2483,5	-54,9	PEAK	100	4,9	-15,1	39,8
hopping	hopping	2400,0	-54,6	PEAK	100	5,2	-14,8	39,8
hopping	hopping	2483,5	-57,1	PEAK	100	5,2	-14,8	42,3

BT n/4 DQPSK (2-DH5)

Channel No.	Channel Center Frequency [MHz]	Band Edge Freq. [MHz]	Spurious Level [dBm]	Detector	RBW [kHz]	Ref. Level [dBm]	Limit [dBm]	Margin to Limit [dB]
0	2402	2400,0	-45,6	PEAK	100	1,9	-18,1	27,5
78	2480	2483,5	-54,6	PEAK	100	1,8	-18,2	36,4
hopping	hopping	2400,0	-49,6	PEAK	100	2,0	-18,0	31,6
hopping	hopping	2483,5	-58,2	PEAK	100	2,0	-18,0	40,2

BT 8-DPSK (3-DH5)

Channel No.	Channel Center Frequency [MHz]	Band Edge Freq. [MHz]	Spurious Level [dBm]	Detector	RBW [kHz]	Ref. Level [dBm]	Limit [dBm]	Margin to Limit [dB]
0	2402	2400,0	-42,8	PEAK	100	2,1	-17,9	24,9
78	2480	2483,5	-51,0	PEAK	100	1,9	-18,1	32,9
hopping	hopping	2400,0	-43,6	PEAK	100	2,1	-17,9	25,7
hopping	hopping	2483,5	-57,5	PEAK	100	2,1	-17,9	39,6

Remark: Please see next sub-clause for the measurement plot.

5.7.4 MEASUREMENT PLOT (EXAMPLE PLOT, SHOWING WORST CASE, IF APPLICABLE)

Radio Technology = Bluetooth BDR, Operating Frequency = low
(S01_AB01)
Band Edge

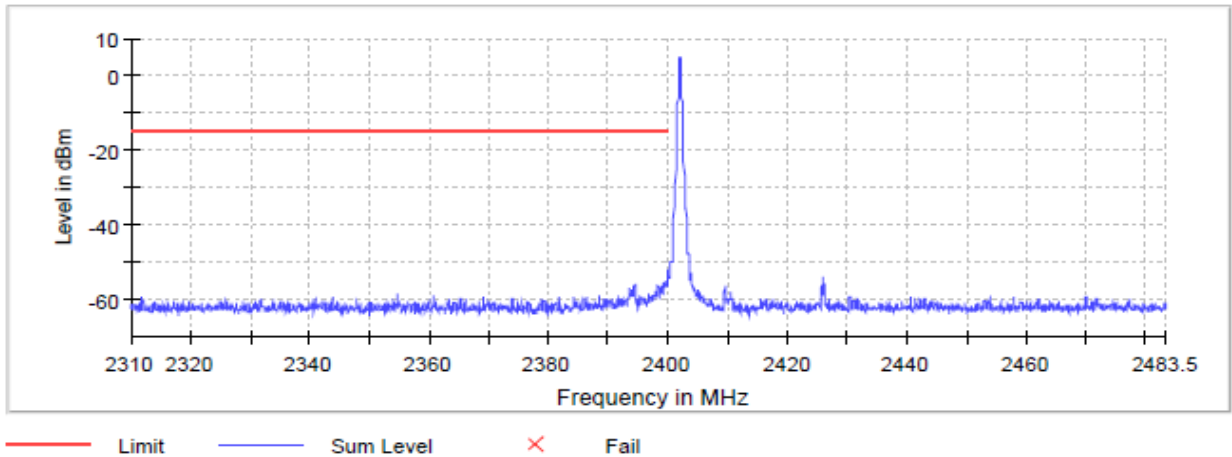

Radio Technology = Bluetooth BDR, Operating Frequency = high
(S01_AB01)
Band Edge

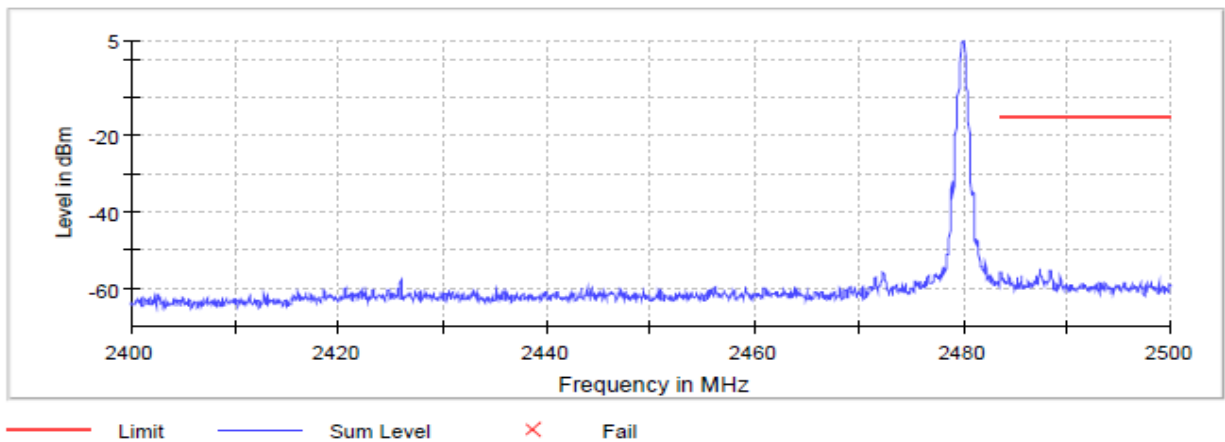

Radio Technology = Bluetooth EDR 2, Operating Frequency = low
(S01_AB01)
Band Edge

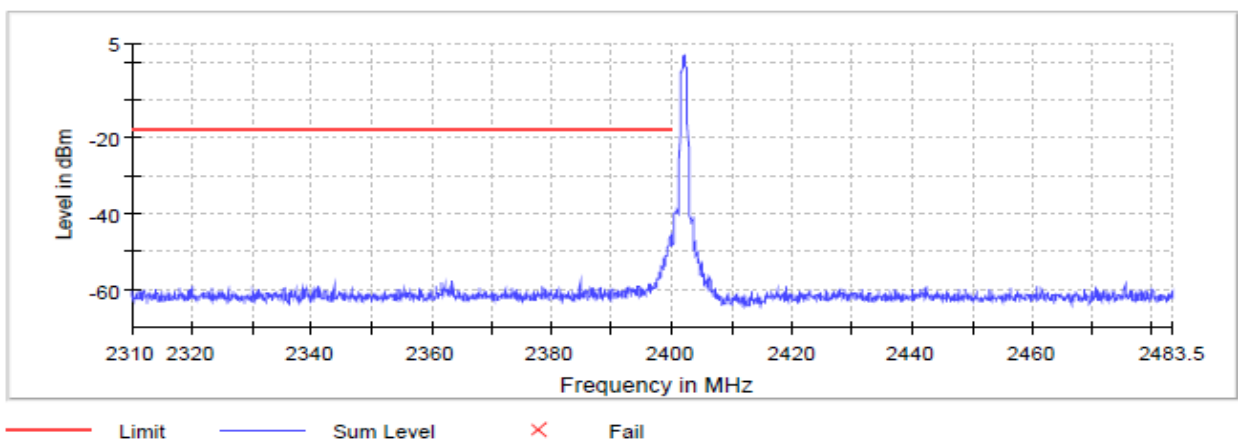

Radio Technology = Bluetooth EDR 2, Operating Frequency = high
(S01_AB01)
Band Edge

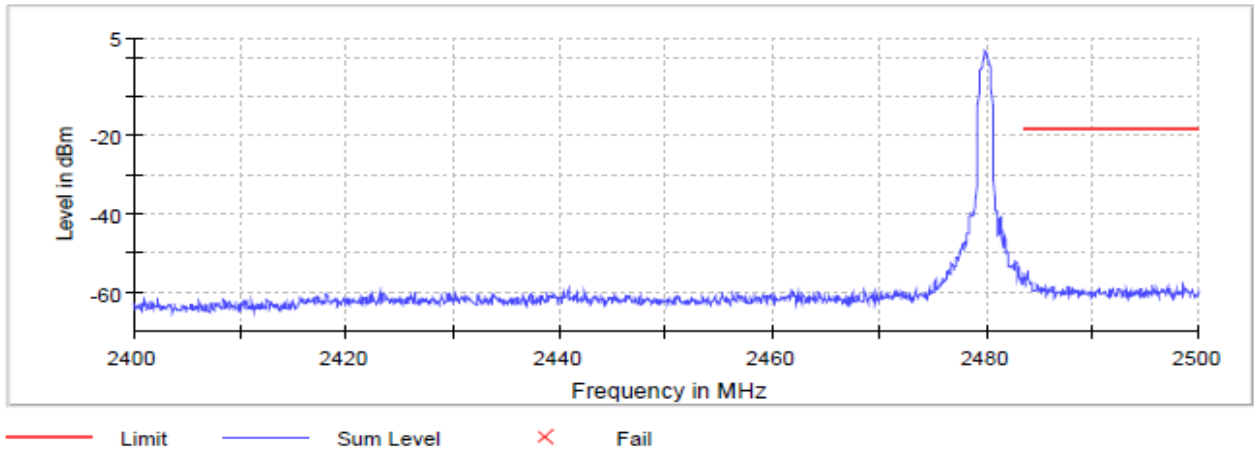

Radio Technology = Bluetooth EDR 3, Operating Frequency = low
(S01_AB01)
Band Edge

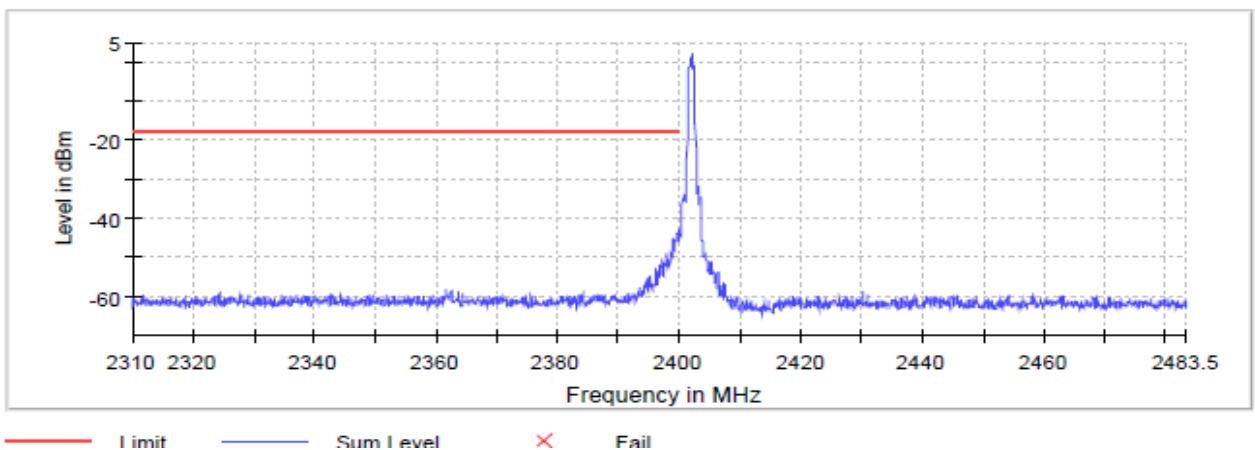

Radio Technology = Bluetooth EDR 3, Operating Frequency = high
(S01_AB01)
Band Edge

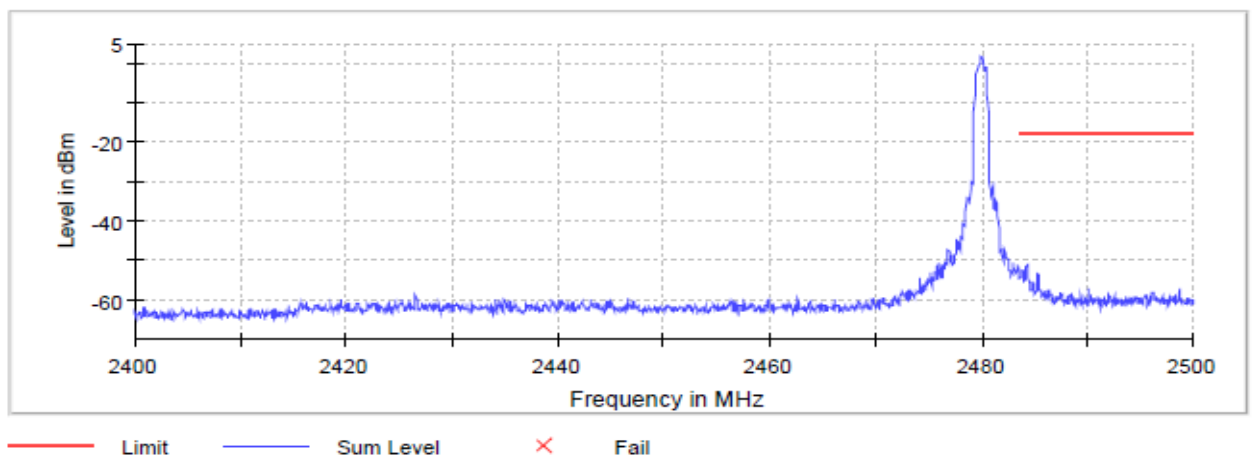

Radio Technology = Bluetooth EDR 3, Operating Frequency = hopping
 (S01_AB01)
 Band Edge

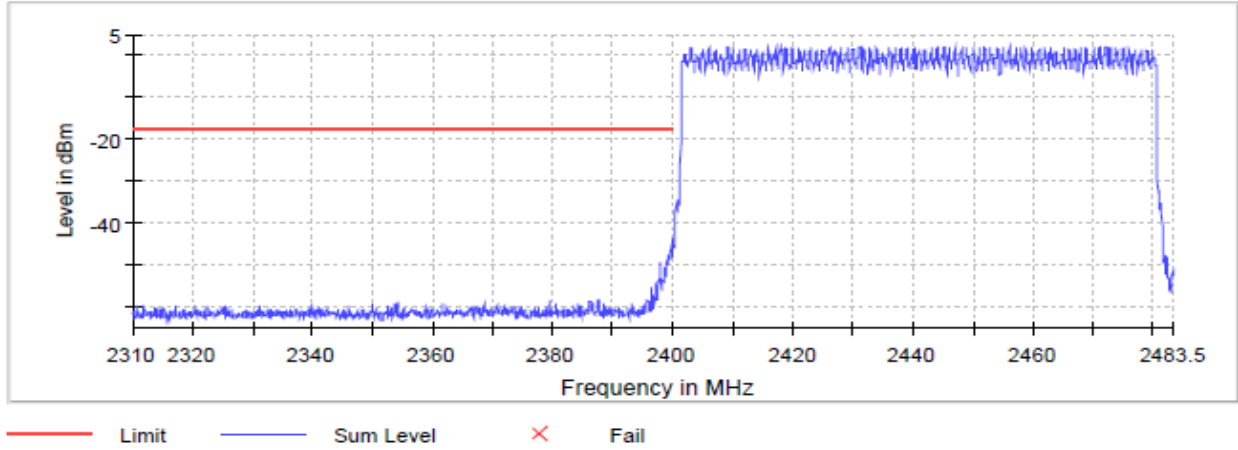

Radio Technology = Bluetooth EDR 2, Operating Frequency = hopping
 (S01_AB01)
 Band Edge

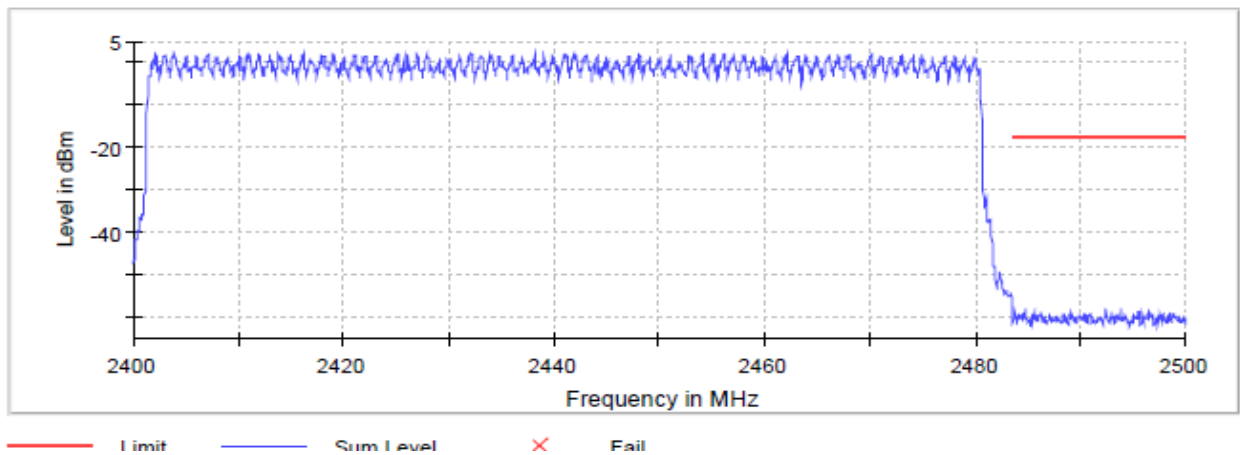

5.7.5 TEST EQUIPMENT USED

- R&S TS8997

5.8 BAND EDGE COMPLIANCE RADIATED

Standard **FCC Part 15 Subpart C**

The test was performed according to:

ANSI C63.10, chapter 6.6.5

5.8.1 TEST DESCRIPTION

The test set-up was made in accordance to the general provisions of ANSI C63.10 in a typical installation configuration. The measurements were performed according the following sub-chapter of ANSI C63.10:

- Chapter 6.10.5

The Equipment Under Test (EUT) was set up on a non-conductive support (tilt device) at 1.5 m height in the fully-anechoic chamber.

All steps were performed with one height (1.5 m) of the receiving antenna only (procedure according ANSI C63.10, chapter 6.6.5).

3. Measurement above 1 GHz

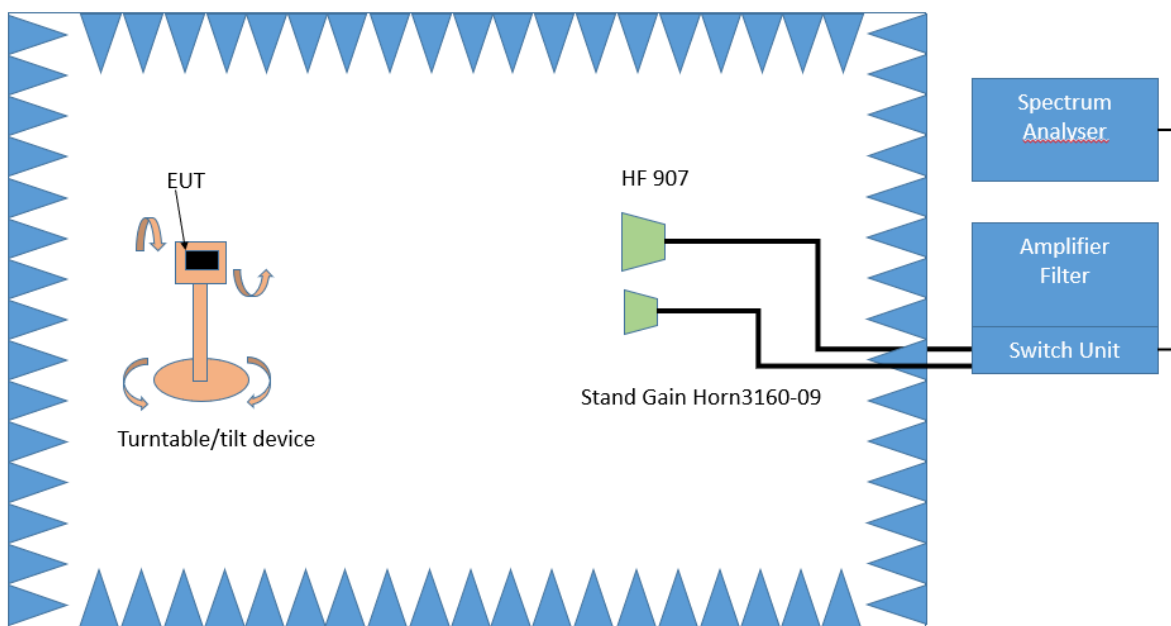

Test Setup; Spurious Emission Radiated (FAC), 1 GHz-26.5 GHz

Step 1:

The EUT is turned during the preliminary measurement across the elevation axis, with a step size of 90 °.

The turn table step size (azimuth angle) for the preliminary measurement is 45 °.

Spectrum analyser settings:

- Detector: Peak, Average
- RBW = 1 MHz
- VBW = 3 MHz

Step 2:

The turn table azimuth will slowly vary by $\pm 22.5^\circ$.

The elevation angle will slowly vary by $\pm 45^\circ$

Spectrum analyser settings:

- Detector: Peak

Step 3:

Spectrum analyser settings for step 3:

- Detector: Peak / CISPR Average
- Measured frequencies: in step 1 determined frequencies
- RBW = 1 MHz
- VBW = 3 MHz
- Measuring time: 1 s

5.8.2 TEST REQUIREMENTS / LIMITS

For band edges connected to a restricted band, the limits are specified in Section 15.209(a)

FCC Part 15, Subpart C, §15.209, Radiated Emission Limits

Frequency in MHz	Limit (µV/m)	Measurement distance (m)	Limits (dBµV/m)
0.009 – 0.49	2400/F(kHz)@300m	3	(48.5 – 13.8)@300m
0.49 – 1.705	24000/F(kHz)@30m	3	(33.8 – 23.0)@30m
1.705 – 30	30@30m	3	29.5@30m

The measured values are corrected with an inverse linear distance extrapolation factor (40 dB/decade) according FCC 15.31 (2).

Frequency in MHz	Limit (µV/m)	Measurement distance (m)	Limits (dBµV/m)
30 – 88	100@3m	3	40.0@3m
88 – 216	150@3m	3	43.5@3m
216 – 960	200@3m	3	46.0@3m
960 – 26000	500@3m	3	54.0@3m
26000 – 40000	500@3m	1	54.0@3m

The measured values above 26 GHz are corrected with an inverse linear distance extrapolation factor (20 dB/decade).

§15.35(b) ..., there is also a limit on the radio frequency emissions, as measured using instrumentation with a peak detector function, corresponding to 20 dB above the maximum permitted average limit....

Used conversion factor: $\text{Limit (dB}\mu\text{V/m)} = 20 \log (\text{Limit } (\mu\text{V/m})/1\mu\text{V/m})$

Since there is no restricted band directly next to the lower band edge, respective emissions are reported in the test case Transmitter Spurious Radiated emissions.

5.8.3 TEST PROTOCOL

Ambient temperature: 23-25 °C
 Air Pressure: 990-1015 hPa
 Humidity: 38-45 %

S02 AB01

BT GFSK (1-DH5)
 Applied duty cycle correction (AV): 0 dB

Ch. No.	Ch. Center Freq. [MHz]	Band Edge Freq. [MHz]	Spurious Level [dBμV/m]	Detector	RBW [kHz]	Limit [dBμV/m]	Margin to Limit [dB]
78	2480	2483,5	48,1	PEAK	1000	74,0	25,9
78	2480	2483,5	35,0	AV	1000	54,0	19,0

BT π/4 DQPSK (2-DH5)
 Applied duty cycle correction (AV): 0 dB

Ch. No.	Ch. Center Freq. [MHz]	Band Edge Freq. [MHz]	Spurious Level [dBμV/m]	Detector	RBW [kHz]	Limit [dBμV/m]	Margin to Limit [dB]
78	2480	2483,5	60,9	PEAK	1000	74,0	13,1
78	2480	2483,5	37,4	AV	1000	54,0	16,6

BT π/8 DQPSK (3-DH5)
 Applied duty cycle correction (AV): 0 dB

Ch. No.	Ch. Center Freq. [MHz]	Band Edge Freq. [MHz]	Spurious Level [dBμV/m]	Detector	RBW [kHz]	Limit [dBμV/m]	Margin to Limit [dB]
78	2480	2483.5	63.5	PEAK	1000	74.0	10.5
78	2480	2483.5	40.7	AV	1000	54.0	13.3

S03 AB01

BT GFSK (1-DH5)
 Applied duty cycle correction (AV): 0 dB

Ch. No.	Ch. Center Freq. [MHz]	Band Edge Freq. [MHz]	Spurious Level [dBμV/m]	Detector	RBW [kHz]	Limit [dBμV/m]	Margin to Limit [dB]
78	2480	2483.5	55.0	PEAK	1000	74.0	19.0
78	2480	2483.5	38.4	AV	1000	54.0	15.6

BT π/8 DQPSK (3-DH5)
 Applied duty cycle correction (AV): 0 dB

Ch. No.	Ch. Center Freq. [MHz]	Band Edge Freq. [MHz]	Spurious Level [dBμV/m]	Detector	RBW [kHz]	Limit [dBμV/m]	Margin to Limit [dB]
78	2480	2483.5	61.8	PEAK	1000	74.0	12.2
78	2480	2483.5	40.0	AV	1000	54.0	14.0

Remark: Please see next sub-clause for the measurement plot.

5.8.4 MEASUREMENT PLOT (EXAMPLE PLOT, SHOWING WORST CASE, IF APPLICABLE)

Radio Technology = Bluetooth BDR, Operating Frequency = high,
Band Edge = high
(S02_AB01)

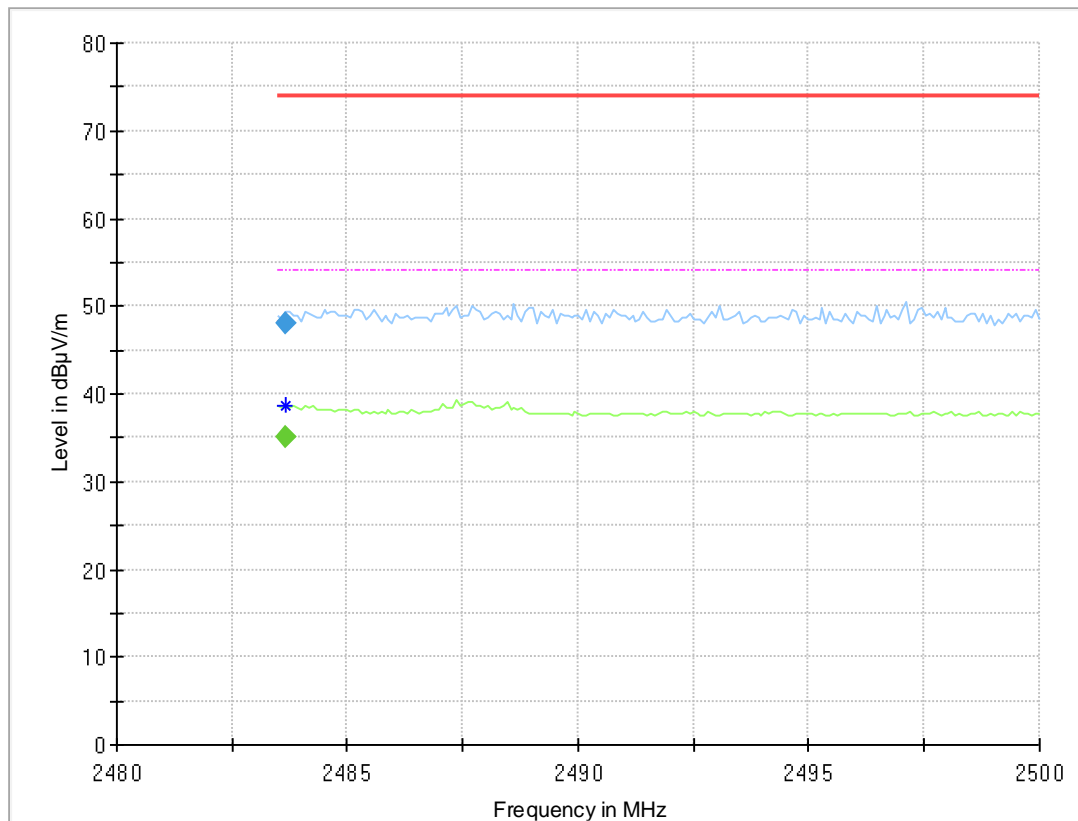

Final Result

Frequency (MHz)	MaxPeak (dBµV/m)	CAverage (dBµV/m)	Limit (dBµV/m)	Margin (dB)	Meas. Time (ms)	Bandwidth (kHz)	Height (cm)	Pol	Azimuth (deg)	Elevation (deg)	Corr. (dB/m)
2483.665	---	35.0	54.00	18.98	1000.0	1000.000	150.0	V	-79.0	96.0	5.3
2483.665	48.1	---	74.00	25.94	1000.0	1000.000	150.0	V	-79.0	96.0	5.3

Radio Technology = Bluetooth EDR 2, Operating Frequency = high,
 Band Edge = high
 (S02_AB01)

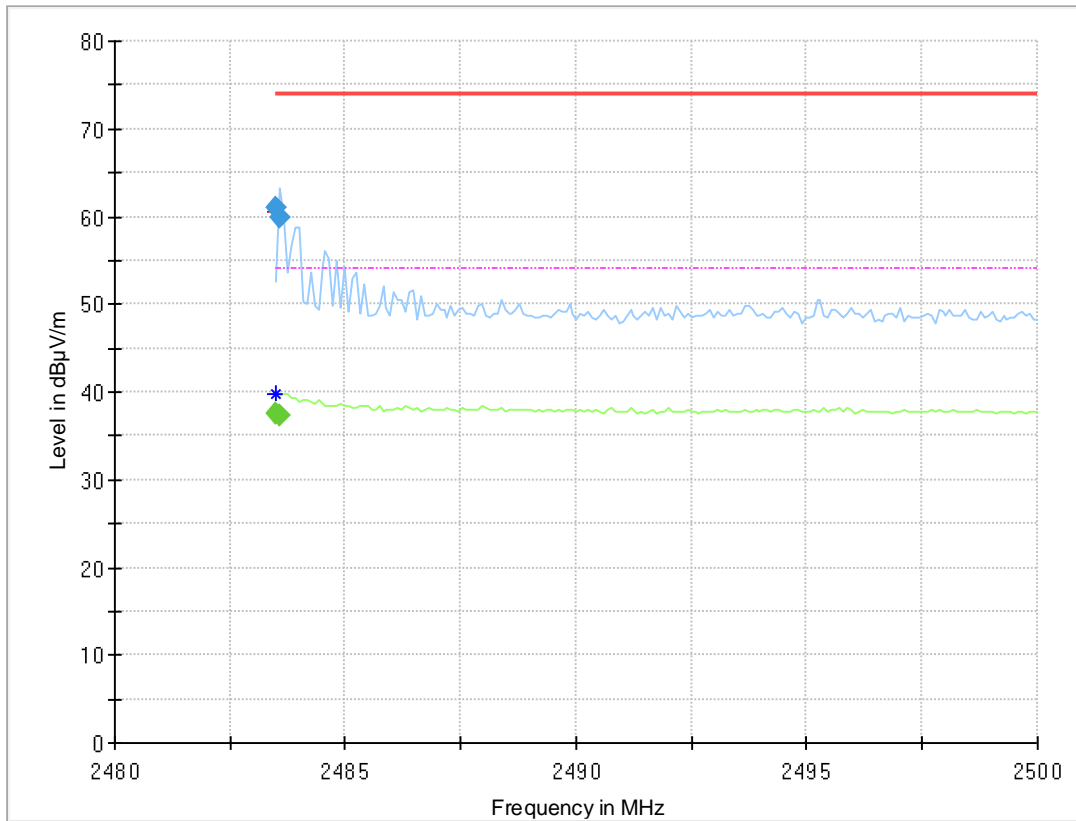

Final Result

Frequency (MHz)	MaxPeak (dBµV/m)	CAverage (dBµV/m)	Limit (dBµV/m)	Margin (dB)	Meas. Time (ms)	Bandwidth (kHz)	Height (cm)	Pol	Azimuth (deg)	Elevation (deg)	Corr. (dB/m)
2483.500	---	37.4	54.00	16.56	1000.0	1000.000	150.0	V	-195.0	5.0	5.3
2483.500	60.9	---	74.00	13.10	1000.0	1000.000	150.0	V	-195.0	5.0	5.3
2483.583	---	37.3	54.00	16.73	1000.0	1000.000	150.0	H	-75.0	80.0	5.3
2483.583	60.0	---	74.00	14.02	1000.0	1000.000	150.0	H	-75.0	80.0	5.3

Radio Technology = Bluetooth EDR 3, Operating Frequency = high,
 Band Edge = high
 (S02_AB01)

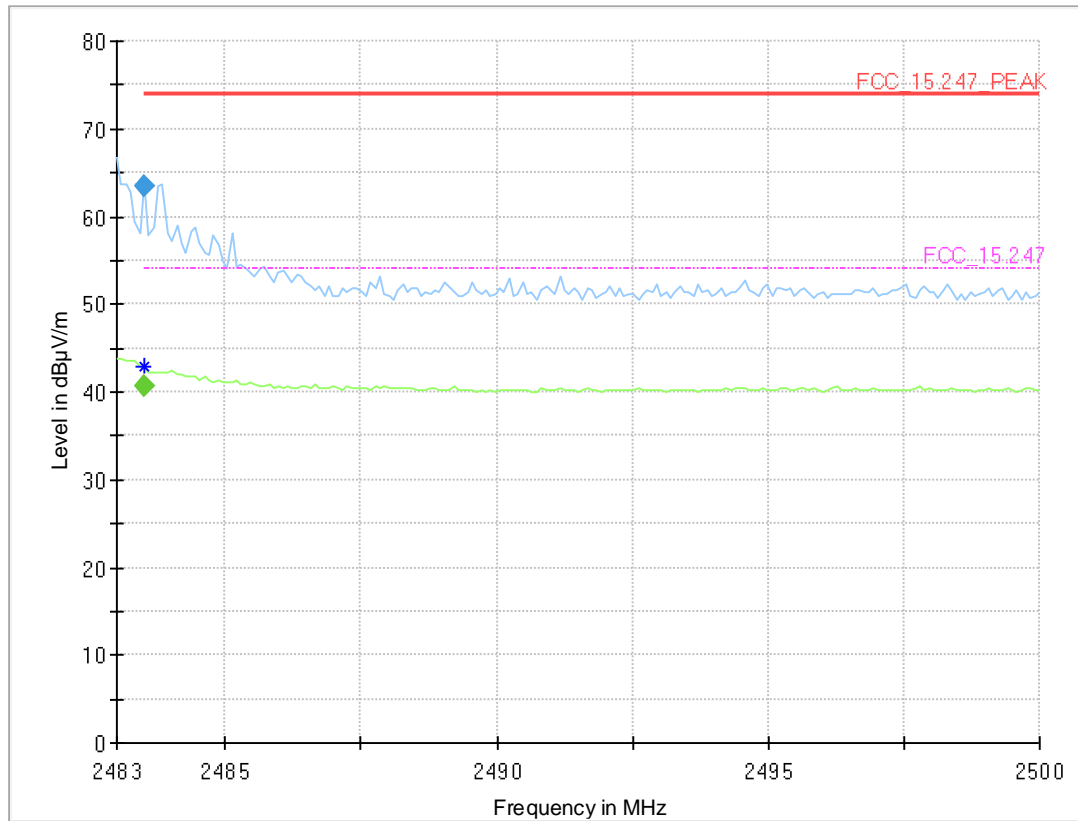

Final Result

Frequency (MHz)	MaxPeak (dBµV/m)	CAverage (dBµV/m)	Limit (dBµV/m)	Margin (dB)	Meas. Time (ms)	Bandwidth (kHz)	Height (cm)	Pol	Azimuth (deg)	Elevation (deg)	Corr. (dB/m)
2483.510	---	40.7	54.00	13.34	1000.0	1000.000	150.0	H	-70.0	104.0	7.8
2483.510	63.5	---	74.00	10.49	1000.0	1000.000	150.0	H	-70.0	104.0	7.8

Radio Technology = Bluetooth BDR, Operating Frequency = high,
 Band Edge = high
 (S03_AB01)

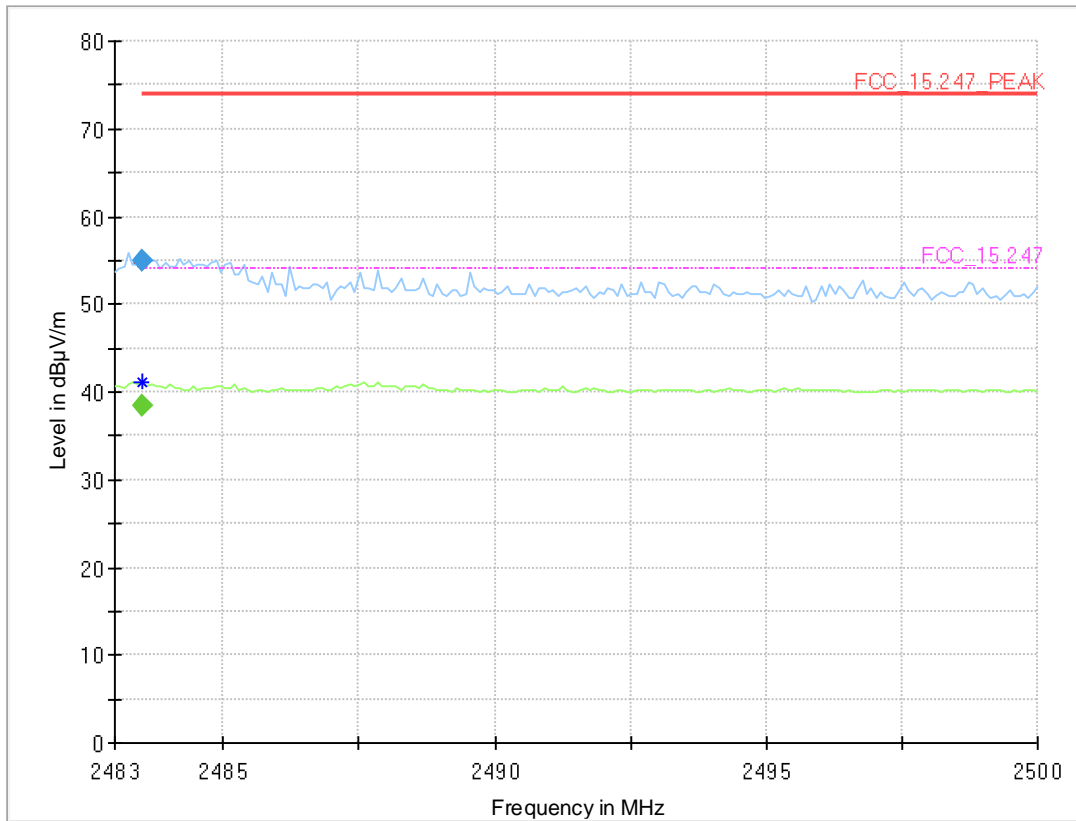

Final_Result

Frequency (MHz)	MaxPeak (dBµV/m)	CAverage (dBµV/m)	Limit (dBµV/m)	Margin (dB)	Meas. Time (ms)	Bandwidth (kHz)	Height (cm)	Pol	Azimuth (deg)	Elevation (deg)	Corr. (dB/m)
2483.510	---	38.4	54.00	15.60	1000.0	1000.000	150.0	H	-65.0	105.0	7.8
2483.510	55.0	---	74.00	19.02	1000.0	1000.000	150.0	H	-65.0	105.0	7.8

Radio Technology = Bluetooth EDR 3, Operating Frequency = high,
 Band Edge = high
 (S03_AB01)

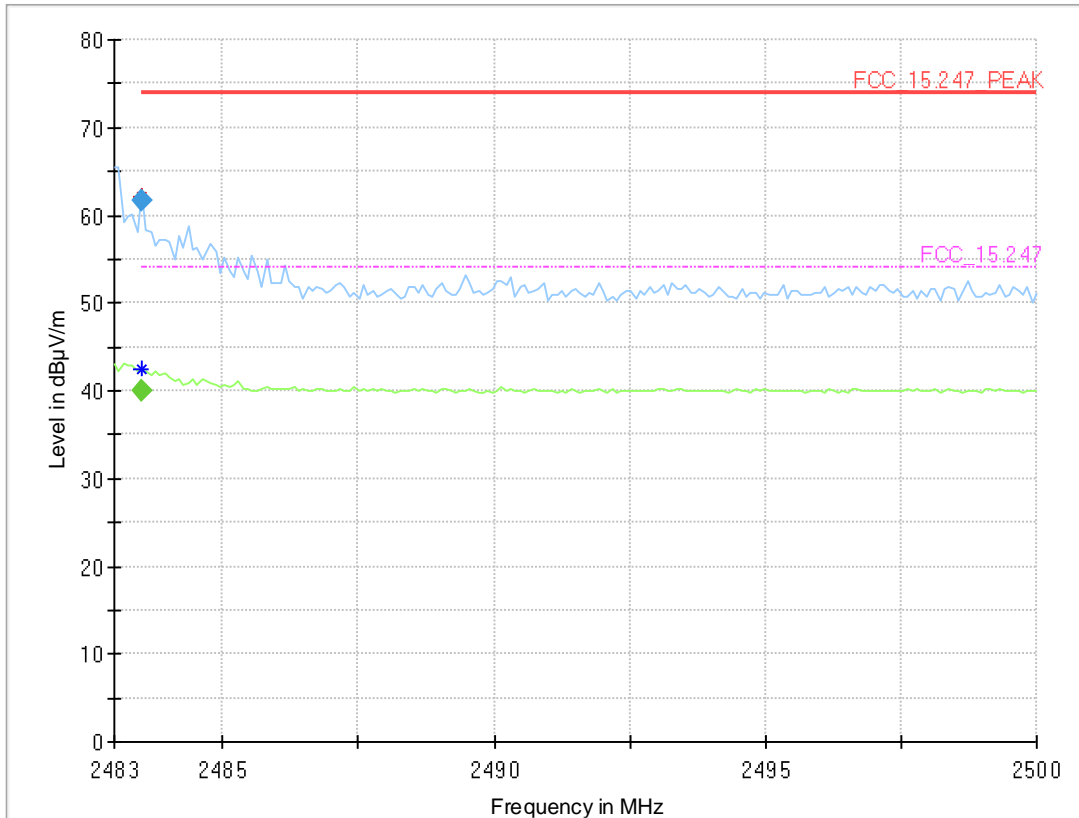

Final Result

Frequency (MHz)	MaxPeak (dBµV/m)	CAverage (dBµV/m)	Limit (dBµV/m)	Margin (dB)	Meas. Time (ms)	Bandwidth (kHz)	Height (cm)	Pol	Azimuth (deg)	Elevation (deg)	Corr. (dB/m)
2483.510	---	40.0	54.00	14.00	1000.0	1000.000	150.0	H	-67.0	94.0	7.8
2483.510	61.8	---	74.00	12.22	1000.0	1000.000	150.0	H	-67.0	94.0	7.8

5.8.5 TEST EQUIPMENT USED

- Radiated Emissions FAR 2.4 GHz FCC

5.9 CHANNEL SEPARATION

Standard **FCC Part 15 Subpart C**

The test was performed according to:

ANSI C63.10, chapter 7.8.2

5.9.1 TEST DESCRIPTION

The Equipment Under Test (EUT) was set up to perform the channel separation measurement. The channel separation is independent of the modulation pattern.

The EUT was connected to the test system as described in the block diagram below. The complete attenuation of the measurement path is known and considered.

Analyser settings:

- Detector: Peak
- Trace: Maxhold
- Span: appr. 3 x OBW
- Centre Frequency: approximate mid of two channels
- Resolution Bandwidth (RBW): appr. 30 % of channel spacing
- Video Bandwidth (VBW): \geq RBW
- Sweep Time: Auto
- Sweeps: Till stable (min. 2000, max. 30000)

The technology depending measurement parameters can be found in the measurement plot.

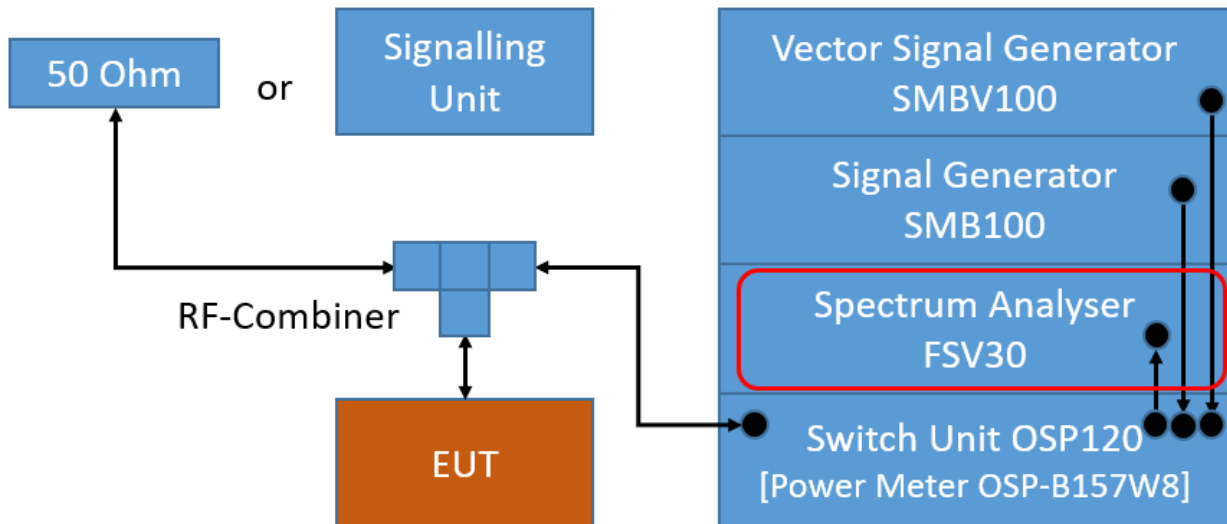

TS8997; Channel Separation

5.9.2 TEST REQUIREMENTS / LIMITS

FCC Part 15, Subpart C, §15.247 (a) (1)

Frequency hopping systems shall have hopping channel carrier frequencies separated by a minimum of 25 kHz or the 20 dB bandwidth of the hopping channel, whichever is greater. Alternatively, frequency hopping systems operating in the 2400–2483.5 MHz band may have hopping channel carrier frequencies that are separated by 25 kHz or two-thirds of the 20 dB bandwidth of the hopping channel, whichever is greater, provided the systems operate with an output power no greater than 125 mW. The system shall hop to channel frequencies that are selected at the system hopping rate from a pseudo randomly ordered list of hopping frequencies. Each frequency must be used equally on the average by each transmitter. The system receivers shall have input bandwidths that match the hopping channel bandwidths of their corresponding transmitters and shall shift frequencies in synchronization with the transmitted signals.

5.9.3 TEST PROTOCOL

Ambient temperature: 24 °C
 Air Pressure: 995 hPa
 Humidity: 40 %

Radio Technology	Channel Separation [MHz]	Limit [MHz]	Margin to Limit [MHz]
BT GFSK (1-DH5)	0,980	0,935	0,045

Remark: Please see next sub-clause for the measurement plot.

5.9.4 MEASUREMENT PLOT (EXAMPLE PLOT, SHOWING WORST CASE, IF APPLICABLE)

Radio Technology = Bluetooth BDR
(S03_AB01)

CFS

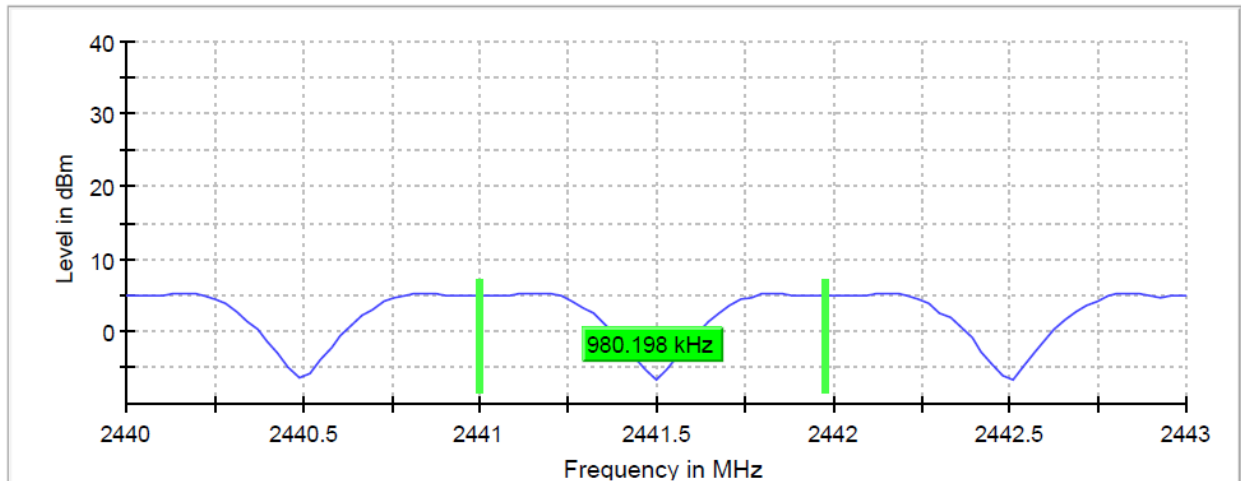

Measurement

Setting	Instrument Value	Target Value
Start Frequency	2.44000 GHz	2.44000 GHz
Stop Frequency	2.44300 GHz	2.44300 GHz
Span	3.000 MHz	3.000 MHz
RBW	300.000 kHz	<= 300.000 kHz
VBW	300.000 kHz	>= 300.000 kHz
SweepPoints	101	~ 10
Sweptime	1.000 ms	AUTO
Reference Level	0.000 dBm	0.000 dBm
Attenuation	10.000 dB	AUTO
Detector	MaxPeak	MaxPeak
SweepCount	200	200
Filter	3 dB	3 dB
Trace Mode	Max Hold	Max Hold
Sweeptype	Sweep	Sweep
Preamp	off	off
Stablemode	Trace	Trace
Stablevalue	0.50 dB	0.50 dB
Run	11 / max. 150	max. 150
Stable	10 / 10	10
Max Stable Difference	0.00 dB	0.50 dB

5.9.5 TEST EQUIPMENT USED

- R&S TS8997

5.10 DWELL TIME

Standard **FCC Part 15 Subpart C**

The test was performed according to:

ANSI C63.10, chapter 7.8.4

5.10.1 TEST DESCRIPTION

The Equipment Under Test (EUT) was set up to perform the dwell time measurement. The dwell time is independent of the modulation pattern. The EUT is set to its maximum dwell time.

The dwell time is measured by spectrum analyser and power meter in parallel. The spectrum analyser video output is connected to the power meter allowing the power meter to measure transmission time only when the EUT is actively transmitting on the measured channel. The power meter is using a time resolution of 1 μ s resulting in a more accurate measurement than possible using the spectrum analyser. In addition, measurement of burst length on more than one transmission is performed this way.

In addition to the calculated dwell time from single burst length, measured dwell time summing up all measured bursts lengths as measured by the power meter is given in the result table.

Calculation for Bluetooth Classic:

Maximum Duty Cycle is given for DH5 packets, resulting in 5 time slots transmission, 1 time slots reception. Each time slot lasts 625 μ s.

Dwell time is calculated as: measured length of a single 5 time slot transmission multiplied by the number of bursts measured by the power meter.

Analyser Settings single 5 slot burst:

- Centre Frequency: mid channel frequency
- Span: Zero span
- Detector: Peak
- Resolution Bandwidth (RBW): \leq Channel separation
- Trigger: Video
- Sweep Time: 3 ms
- Sweep Points: 30001
- Single Sweep

Analyser setting full sweep:

- Centre Frequency: mid channel frequency
- Span: Zero span
- Detector: Peak
- Resolution Bandwidth (RBW): \leq Channel separation
- Trigger: External
- Sweep Time: 31.6 s
- Sweep Points: 30001
- Single Sweep

Time resolution of power meter: 1 μ s

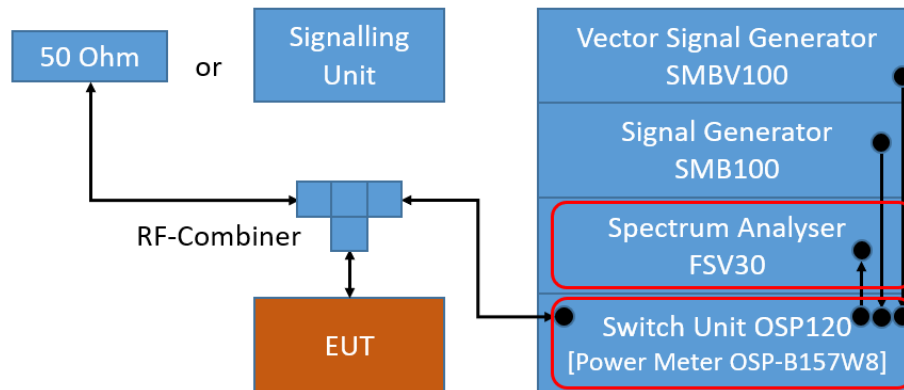

TS8997; Dwell Time

5.10.2 TEST REQUIREMENTS / LIMITS

For the band: 902 – 928 MHz
 FCC Part 15, Subpart C, §15.247 (a) (1) (i)

If the 20 dB bandwidth of the hopping channel is less than 250 kHz the average time of occupancy on any frequency shall not be greater than 0.4 seconds within a 20 second period. If the 20 dB bandwidth of the hopping channel is 250 kHz or greater, the average time of occupancy on any frequency shall not be greater than 0.4 seconds within a 10 second period.

For the band: 5725 – 5850 MHz
 FCC Part 15, Subpart C, §15.247 (a) (1) (ii)

The average time of occupancy on any frequency shall not be greater than 0.4 seconds within a 30 second period.

For the frequency band 2400 – 2483.5 MHz:
 FCC Part 15, Subpart C, §15.247 (a) (1) (iii)

...The average time of occupancy on any channel shall not be greater than 0.4 seconds within a period of 0.4 seconds multiplied by the number of hopping channels employed. Since the Bluetooth technology uses 79 channels this period is calculated to be 31.6 seconds.

FCC Part 15, Subpart C, §15.247 (f)

(f) For the purposes of this section, hybrid systems are those that employ a combination of both frequency hopping and digital modulation techniques. The frequency hopping operation of the hybrid system, with the direct sequence or digital modulation operation turned-off, shall have an average time of occupancy on any frequency not to exceed 0.4 seconds within a time period in seconds equal to the number of hopping frequencies employed multiplied by 0.4.

...

5.10.3 TEST PROTOCOL

Ambient temperature: 24 °C
 Air Pressure: 995 hPa
 Humidity: 40 %

Radio Technology	Measured Slot Length [ms]	Measured Number of Slots	Calculated Dwell Time [ms]	Limit [ms]	Margin to Limit [ms]
BT GFSK (1-DH5)	2,900	100	290,000	400,0	110,000

Remark: Please see next sub-clause for the measurement plot.

5.10.4 MEASUREMENT PLOT (EXAMPLE PLOT, SHOWING WORST CASE, IF APPLICABLE)

Radio Technology = Bluetooth BDR
 (S01_AB01)

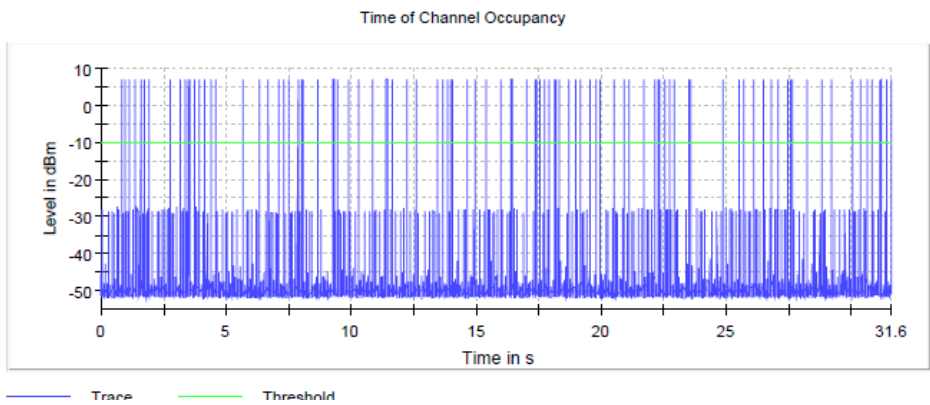

Measurement

Setting	Instrument Value
Center Frequency	2.44100 GHz
Span	ZeroSpan
RBW	500.000 kHz
VBW	1.000 MHz
SweepPoints	30001
Sweptime	31.600 s
Reference Level	-20.000 dBm
Attenuation	0.000 dB
Detector	MaxPeak
SweepCount	1
Filter	Channel
Trace Mode	Clear Write
SweepType	Sweep
Preamp	off
Trigger	External
Trigger Offset	0.000 s

5.10.5 TEST EQUIPMENT USED

- R&S TS8997

5.11 NUMBER OF HOPPING FREQUENCIES

Standard **FCC Part 15 Subpart C**

The test was performed according to:

ANSI C63.10, chapter 7.8.3

5.11.1 TEST DESCRIPTION

The Equipment Under Test (EUT) was set up to perform the number of hopping frequencies measurement. The number of hopping frequencies is independent of the modulation pattern.

The EUT was connected to the test system as described in the block diagram below. The complete attenuation of the measurement path is known and considered.

Analyser settings:

- Detector: Peak
- Trace: Maxhold
- Frequency span: Frequency band of operation
- Resolution Bandwidth (RBW): < 30 % of channel spacing or 20 dB bandwidth (whichever is smaller)
- Video Bandwidth (VBW): 3 x RBW
- Sweep Time: Auto
- Sweeps: Till stable (min. 300, max. 15000)

The technology depending measurement parameters can be found in the measurement plot.

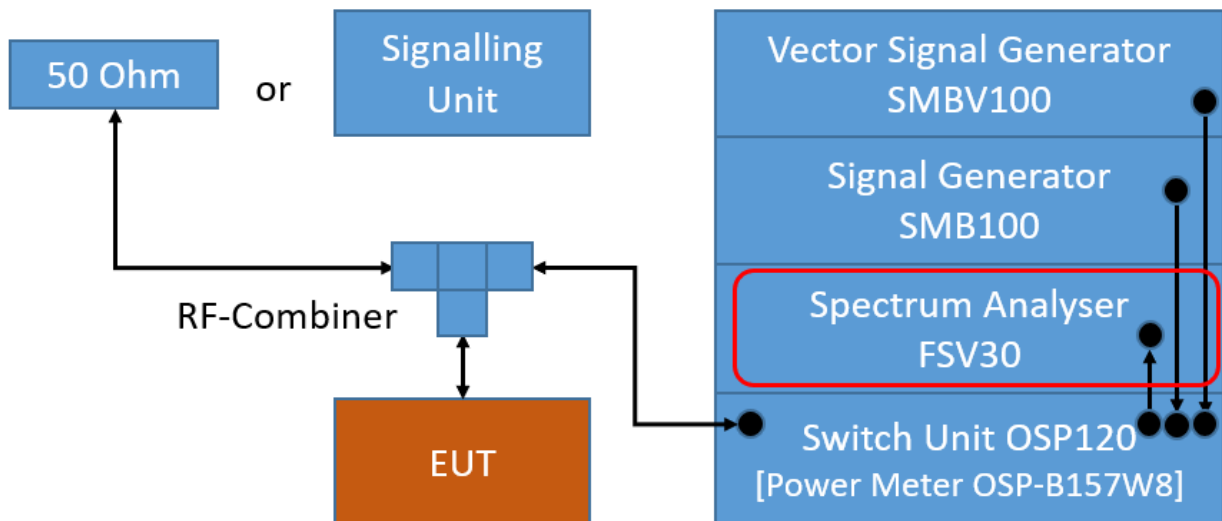

TS8997; Number of Hopping Frequencies

5.11.2 TEST REQUIREMENTS / LIMITS

For the band: 902 – 928 MHz
FCC Part 15, Subpart C, §15.247 (a) (1) (i)

If the 20 dB bandwidth of the hopping channel is less than 250 kHz, the system shall use at least 50 hopping frequencies.
If the 20 dB bandwidth of the hopping channel is 250 kHz or greater, the system shall use at least 25 hopping frequencies

For the band: 5725 – 5850 MHz
FCC Part 15, Subpart C, §15.247 (a) (1) (ii)

Frequency hopping systems operating in the 5725-5850 MHz band shall use at least 75 hopping frequencies.

For the band: 2400 – 2483.5 MHz
FCC Part 15, Subpart C, §15.247 (a) (1) (iii)

Frequency hopping systems in the 2400-2483.5 MHz band shall use at least 15 channels.

5.11.3 TEST PROTOCOL

Ambient temperature: 25 °C
Air Pressure: 990 hPa
Humidity: 40 %

Radio Technology	Number of Hopping Frequencies	Limit	Margin to Limit
BT GFSK (1-DH5)	79	15	64

Remark: Please see next sub-clause for the measurement plot.

5.11.4 MEASUREMENT PLOT (EXAMPLE PLOT, SHOWING WORST CASE, IF APPLICABLE)

Radio Technology = Bluetooth BDR
(S01_AB01)

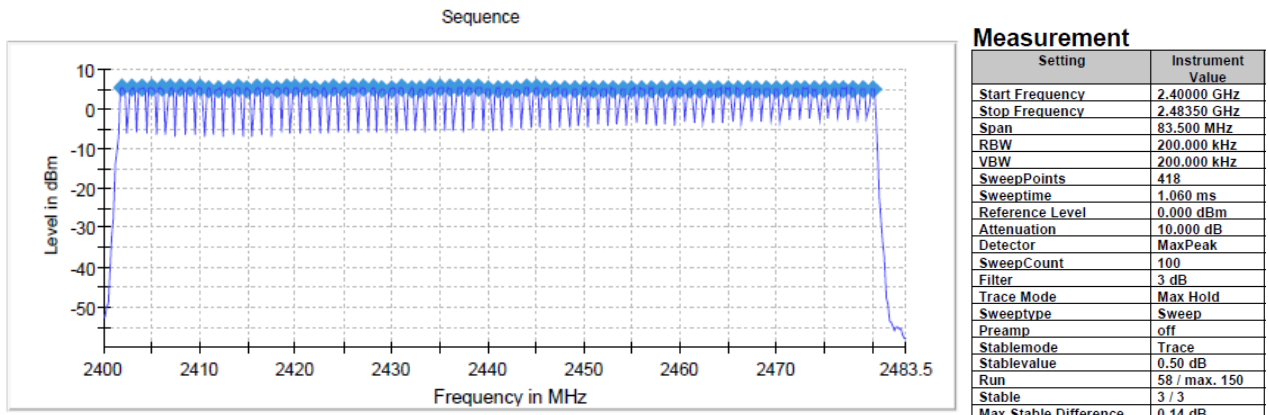

5.11.5 TEST EQUIPMENT USED

- R&S TS8997

6 TEST EQUIPMENT

6.1 TEST EQUIPMENT HARDWARE

- 1 Conducted Emissions FCC
Conducted Emissions AC Mains for FCC standards

Ref.No.	Device Name	Description	Manufacturer	Serial Number	Last Calibration	Calibration Due
1.1	Chroma 6404	AC Source	Chroma ATE INC.	64040001304	N/A	N/A
1.2	Shielded Room 02	Shielded Room 4m x 3m	Frankonia Germany EMC Solution GmbH	-	N/A	N/A
1.3	ESH3-Z5	Two-Line V-Network (EUT)	Rohde & Schwarz GmbH & Co. KG	829996/002	2023-09	2025-09
1.4	ESR 7	EMI Receiver / Spectrum Analyzer	Rohde & Schwarz	101424	2023-01	2025-01

- 1 R&S TS8997
2.4 and 5 GHz Bands Conducted Test Lab

Ref.No.	Device Name	Description	Manufacturer	Serial Number	Last Calibration	Calibration Due
1.1	Opus10 TPR (8253.00)	T/P Logger 13	Lufft Mess- und Regeltechnik GmbH	13936	2021-10	2023-10
1.2	SMB100A	Signal Generator 9 kHz - 6 GHz	Rohde & Schwarz	107695	2021-06	2024-06
1.3	EX520	Digital Multimeter 12	Extech Instruments Corp	05157876	2022-06	2024-06
1.4	FSV30	Signal Analyzer 10 Hz - 30 GHz	Rohde & Schwarz	103005	2023-08	2025-08
1.5	NGSM 32/10	Power Supply	Rohde & Schwarz GmbH & Co. KG	3456	2022-01	2024-01
1.6	Temperature Chamber KWP 120/70	Temperature Chamber Weiss 01	Weiss	59226012190010	2022-05	2024-05
1.7	Temperature Chamber VT 4002	Temperature Chamber Vötsch 03	Vötsch	58566002150010	2022-05	2024-05
1.8	FSW43	Signal Analyser	Rohde & Schwarz GmbH & Co. KG	102013	2023-07	2025-07
1.9	Opus10 THI (8152.00)	T/H Logger 14	Lufft Mess- und Regeltechnik GmbH	13993		
1.10	SMBV100A	Vector Signal Generator 9 kHz - 6 GHz	Rohde & Schwarz	259291	2023-01	2026-01
1.11	OSP120	Contains Power Meter and Switching Unit OSP-B157W8 PLUS	Rohde & Schwarz	101158	2021-08	2024-08
1.12	CS-RUB6	Rubidium Frequency Standard	Rohde & Schwarz GmbH & Co. KG	100321	2022-10	2023-10

2 Radiated Emissions FAR 2.4 GHz FCC
 Radiated emission tests for 2.4 GHz ISM devices in a fully anechoic room

Ref.No.	Device Name	Description	Manufacturer	Serial Number	Last Calibration	Calibration Due
2.1	Innco Systems CO3000	Controller for bore sight mast FAC		CO3000/1460/54740522/P	N/A	N/A
2.2	AMF-7D00101800-30-10P-R	Broadband Amplifier 100 MHz - 18 GHz	Miteq		N/A	N/A
2.3	Anechoic Chamber 03	FAR, 8.80m x 4.60m x 4.05m (l x w x h)	Albatross Projects	P26971-647-001-PRB	N/A	N/A
2.4	Fluke 177	Digital Multimeter 03 (Multimeter)	Fluke Europe B.V.	86670383	2023-08	2025-08
2.5	JS4-18002600-32-5P	Broadband Amplifier 18 GHz - 26 GHz	Miteq	849785	N/A	N/A
2.6	FSW43	Spectrum Analyzer	Rohde & Schwarz GmbH & Co. KG	103779	2023-04	2025-04
2.7	EP 1200/B, NA/B1	AC Source, Amplifier with integrated variable Oscillator	Spitzenberger & Spies GmbH & Co. KG	B6278	N/A	N/A
2.8	3160-09	Standard Gain / Pyramidal Horn Antenna 26.5 GHz	EMCO Elektronik GmbH	00083069	N/A	N/A
2.9	WHKX 7.0/18G-8SS	High Pass Filter	Wainwright Instruments GmbH	09	N/A	N/A
2.10	MA3000/0800-XP-ET-compact	Bore Sight Antenna Mast			N/A	N/A
2.11	TT 1.5 WI	Turn Table	Maturo GmbH	-	N/A	N/A
2.12	5HC3500/18000-1.2-KK	High Pass Filter	Trilithic	200035008	N/A	N/A
2.13	Opus 20 THI (8120.00)	ThermoHygro Datalogger	Lufft Mess- und Regeltechnik GmbH	115.0318.0802.033	2023-08	2025-08
2.14	TD1.5-10kg	EUT Tilt Device (Rohacell)	Maturo GmbH	TD1.5-10kg/024/3790709	N/A	N/A
2.15	AFS42-00101800-25-S-42	Broadband Amplifier 25 MHz - 18 GHz	Miteq	2035324	N/A	N/A
2.16	HF 907	Double-ridged horn	Rohde & Schwarz	102444	2021-09	2024-09

3 Radiated Emissions SAC H-Field
 Radiated emission tests in the H-Field in a semi anechoic room

Ref.No.	Device Name	Description	Manufacturer	Serial Number	Last Calibration	Calibration Due
3.1	N5000/NP	Filter for EUT, 2 Lines, 250 V, 16 A	ETS-LINDGREN	241515	N/A	N/A

Ref.No.	Device Name	Description	Manufacturer	Serial Number	Last Calibration	Calibration Due
3.2	ESW44	EMI Receiver / Spectrum Analyzer	Rohde & Schwarz GmbH & Co. KG	101603	2022-01	2024-01
3.3	Anechoic Chamber 01	SAC/FAR, 10.58 m x 6.38 m x 6.00 m	Frankonia	none	N/A	N/A
3.4	Fluke 177	Digital Multimeter 03 (Multimeter)	Fluke Europe B.V.	86670383	2023-08	2025-08
3.5	EP 1200/B, NA/B1	AC Source, Amplifier with integrated variable Oscillator	Spitzenberger & Spies GmbH & Co. KG	B6278	N/A	N/A
3.6	DS 420S	Turn Table 2 m diameter	HD GmbH	420/573/99	N/A	N/A
3.7	HFH2-Z2	Loop Antenna + 3 Axis Tripod	Rohde & Schwarz GmbH & Co. KG	829324/006	2021-01	2024-01

4 Radiated Emissions SAC up to 1 GHz
 Radiated emission tests up to 1 GHz in a semi anechoic room

Ref.No.	Device Name	Description	Manufacturer	Serial Number	Last Calibration	Calibration Due
4.1	N5000/NP	Filter for EUT, 2 Lines, 250 V, 16 A	ETS-LINDGREN	241515	N/A	N/A
4.2	ESW44	EMI Receiver / Spectrum Analyzer	Rohde & Schwarz GmbH & Co. KG	101603	2022-01	2024-01
4.3	Anechoic Chamber 01	SAC/FAR, 10.58 m x 6.38 m x 6.00 m	Frankonia	none	N/A	N/A
4.4	HL 562 ULTRALOG	Biconical-log-per antenna (30 MHz - 3 GHz) with HL 562E biconicals	Rohde & Schwarz GmbH & Co. KG	830547/003	2021-09	2024-09
4.5	EP 1200/B, NA/B1	AC Source, Amplifier with integrated variable Oscillator	Spitzenberger & Spies GmbH & Co. KG	B6278	N/A	N/A
4.6	DS 420S	Turn Table 2 m diameter	HD GmbH	420/573/99	N/A	N/A
4.7	AM 4.0	Antenna Mast 4 m	Maturo GmbH	AM4.0/180/1192 0513	N/A	N/A

The calibration interval is the time interval between "Last Calibration" and "Calibration Due"

6.2 TEST EQUIPMENT SOFTWARE

Semi-Anechoic Chamber:	
Software	Version
EMC32 Measurement Software	10.60.10
INNCO Mast Controller	1.02.62
MATURO Mast Controller	12.19
MATURO Turn-Table Controller	30.10
Fully-Anechoic Chamber:	
Software	Version
EMC32 Measurement Software	10.60.10
MATURO Turn-Unit Controller	11.10
MATURO Mast Controller	12.10
MATURO Turntable Controller	12.11
INNCO Mast Controller	1.02.62
TS 8997	
WMC32 Measurement Software	11.40.00
Conducted AC Emissions:	
Software	Version
EMC32 Measurement Software	10.60.20

7 ANTENNA FACTORS, CABLE LOSS AND SAMPLE CALCULATIONS

This chapter contains the antenna factors with their corresponding path loss of the used measurement path for all antennas as well as the insertion loss of the LISN.

7.1 LISN R&S ESH3-Z5 (150 KHZ – 30 MHZ)

Frequency MHz	Corr. dB	LISN insertion loss ESH3- Z5 dB	cable loss (incl. 10 dB atten- uator) dB
0.15	10.1	0.1	10.0
5	10.3	0.1	10.2
7	10.5	0.2	10.3
10	10.5	0.2	10.3
12	10.7	0.3	10.4
14	10.7	0.3	10.4
16	10.8	0.4	10.4
18	10.9	0.4	10.5
20	10.9	0.4	10.5
22	11.1	0.5	10.6
24	11.1	0.5	10.6
26	11.2	0.5	10.7
28	11.2	0.5	10.7
30	11.3	0.5	10.8

Sample calculation

$$U_{\text{LISN}} (\text{dB } \mu\text{V}) = U (\text{dB } \mu\text{V}) + \text{Corr. (dB)}$$

U = Receiver reading

LISN Insertion loss = Voltage Division Factor of LISN

Corr. = sum of single correction factors of used LISN, cables, switch units (if used)

Linear interpolation will be used for frequencies in between the values in the table.

7.2 ANTENNA R&S HFH2-Z2 (9 KHZ – 30 MHZ)

Frequency MHz	AF HFH-Z2) dB (1/m)	Corr. dB	cable loss 1 (inside chamber) dB	cable loss 2 (outside chamber) dB	cable loss 3 (switch unit) dB	cable loss 4 (to receiver) dB	distance corr. (-40 dB/ decade) dB	d _{Limit} (meas. distance (limit) m	d _{used} (meas. distance (used) m
0.009	20.50	-79.6	0.1	0.1	0.1	0.1	-80	300	3
0.01	20.45	-79.6	0.1	0.1	0.1	0.1	-80	300	3
0.015	20.37	-79.6	0.1	0.1	0.1	0.1	-80	300	3
0.02	20.36	-79.6	0.1	0.1	0.1	0.1	-80	300	3
0.025	20.38	-79.6	0.1	0.1	0.1	0.1	-80	300	3
0.03	20.32	-79.6	0.1	0.1	0.1	0.1	-80	300	3
0.05	20.35	-79.6	0.1	0.1	0.1	0.1	-80	300	3
0.08	20.30	-79.6	0.1	0.1	0.1	0.1	-80	300	3
0.1	20.20	-79.6	0.1	0.1	0.1	0.1	-80	300	3
0.2	20.17	-79.6	0.1	0.1	0.1	0.1	-80	300	3
0.3	20.14	-79.6	0.1	0.1	0.1	0.1	-80	300	3
0.49	20.12	-79.6	0.1	0.1	0.1	0.1	-80	300	3
0.490001	20.12	-39.6	0.1	0.1	0.1	0.1	-40	30	3
0.5	20.11	-39.6	0.1	0.1	0.1	0.1	-40	30	3
0.8	20.10	-39.6	0.1	0.1	0.1	0.1	-40	30	3
1	20.09	-39.6	0.1	0.1	0.1	0.1	-40	30	3
2	20.08	-39.6	0.1	0.1	0.1	0.1	-40	30	3
3	20.06	-39.6	0.1	0.1	0.1	0.1	-40	30	3
4	20.05	-39.5	0.2	0.1	0.1	0.1	-40	30	3
5	20.05	-39.5	0.2	0.1	0.1	0.1	-40	30	3
6	20.02	-39.5	0.2	0.1	0.1	0.1	-40	30	3
8	19.95	-39.5	0.2	0.1	0.1	0.1	-40	30	3
10	19.83	-39.4	0.2	0.1	0.2	0.1	-40	30	3
12	19.71	-39.4	0.2	0.1	0.2	0.1	-40	30	3
14	19.54	-39.4	0.2	0.1	0.2	0.1	-40	30	3
16	19.53	-39.3	0.3	0.1	0.2	0.1	-40	30	3
18	19.50	-39.3	0.3	0.1	0.2	0.1	-40	30	3
20	19.57	-39.3	0.3	0.1	0.2	0.1	-40	30	3
22	19.61	-39.3	0.3	0.1	0.2	0.1	-40	30	3
24	19.61	-39.3	0.3	0.1	0.2	0.1	-40	30	3
26	19.54	-39.3	0.3	0.1	0.2	0.1	-40	30	3
28	19.46	-39.2	0.3	0.1	0.3	0.1	-40	30	3
30	19.73	-39.1	0.4	0.1	0.3	0.1	-40	30	3

Sample calculation

$$E \text{ (dB } \mu\text{V/m)} = U \text{ (dB } \mu\text{V)} + \text{AF (dB 1/m)} + \text{Corr. (dB)}$$

U = Receiver reading

AF = Antenna factor

Corr. = sum of single correction factors of used cables, switch unit, distance correction, amplifier (if applicable)

distance correction = $-40 * \text{LOG} (d_{\text{Limit}} / d_{\text{used}})$

Linear interpolation will be used for frequencies in between the values in the table.

Table shows an extract of values

7.3 ANTENNA R&S HL562 (30 MHZ – 1 GHZ)

($d_{Limit} = 3 \text{ m}$)

Frequency MHz	AF R&S HL562 dB (1/m)	Corr. dB
30	18.6	0.6
50	6.0	0.9
100	9.7	1.2
150	7.9	1.6
200	7.6	1.9
250	9.5	2.1
300	11.0	2.3
350	12.4	2.6
400	13.6	2.9
450	14.7	3.1
500	15.6	3.2
550	16.3	3.5
600	17.2	3.5
650	18.1	3.6
700	18.5	3.6
750	19.1	4.1
800	19.6	4.1
850	20.1	4.4
900	20.8	4.7
950	21.1	4.8
1000	21.6	4.9

cable loss 1 (inside chamber) dB	cable loss 2 (outside chamber) dB	cable loss 3 (switch unit) dB	cable loss 4 (to receiver) dB	distance corr. (-20 dB/ decade) dB	d_{Limit} (meas. distance (limit)) m	d_{used} (meas. distance (used)) m
0.29	0.04	0.23	0.02	0.0	3	3
0.39	0.09	0.32	0.08	0.0	3	3
0.56	0.14	0.47	0.08	0.0	3	3
0.73	0.20	0.59	0.12	0.0	3	3
0.84	0.21	0.70	0.11	0.0	3	3
0.98	0.24	0.80	0.13	0.0	3	3
1.04	0.26	0.89	0.15	0.0	3	3
1.18	0.31	0.96	0.13	0.0	3	3
1.28	0.35	1.03	0.19	0.0	3	3
1.39	0.38	1.11	0.22	0.0	3	3
1.44	0.39	1.20	0.19	0.0	3	3
1.55	0.46	1.24	0.23	0.0	3	3
1.59	0.43	1.29	0.23	0.0	3	3
1.67	0.34	1.35	0.22	0.0	3	3
1.67	0.42	1.41	0.15	0.0	3	3
1.87	0.54	1.46	0.25	0.0	3	3
1.90	0.46	1.51	0.25	0.0	3	3
1.99	0.60	1.56	0.27	0.0	3	3
2.14	0.60	1.63	0.29	0.0	3	3
2.22	0.60	1.66	0.33	0.0	3	3
2.23	0.61	1.71	0.30	0.0	3	3

($d_{Limit} = 10 \text{ m}$)

Frequency MHz	AF R&S HL562 dB (1/m)	Corr. dB
30	18.6	-9.9
50	6.0	-9.6
100	9.7	-9.2
150	7.9	-8.8
200	7.6	-8.6
250	9.5	-8.3
300	11.0	-8.1
350	12.4	-7.9
400	13.6	-7.6
450	14.7	-7.4
500	15.6	-7.2
550	16.3	-7.0
600	17.2	-6.9
650	18.1	-6.9
700	18.5	-6.8
750	19.1	-6.3
800	19.6	-6.3
850	20.1	-6.0
900	20.8	-5.8
950	21.1	-5.6
1000	21.6	-5.6

cable loss 1 (inside chamber) dB	cable loss 2 (outside chamber) dB	cable loss 3 (switch unit) dB	cable loss 4 (to receiver) dB	distance corr. (-20 dB/ decade) dB	d_{Limit} (meas. distance (limit)) m	d_{used} (meas. distance (used)) m
0.29	0.04	0.23	0.02	-10.5	10	3
0.39	0.09	0.32	0.08	-10.5	10	3
0.56	0.14	0.47	0.08	-10.5	10	3
0.73	0.20	0.59	0.12	-10.5	10	3
0.84	0.21	0.70	0.11	-10.5	10	3
0.98	0.24	0.80	0.13	-10.5	10	3
1.04	0.26	0.89	0.15	-10.5	10	3
1.18	0.31	0.96	0.13	-10.5	10	3
1.28	0.35	1.03	0.19	-10.5	10	3
1.39	0.38	1.11	0.22	-10.5	10	3
1.44	0.39	1.20	0.19	-10.5	10	3
1.55	0.46	1.24	0.23	-10.5	10	3
1.59	0.43	1.29	0.23	-10.5	10	3
1.67	0.34	1.35	0.22	-10.5	10	3
1.67	0.42	1.41	0.15	-10.5	10	3
1.87	0.54	1.46	0.25	-10.5	10	3
1.90	0.46	1.51	0.25	-10.5	10	3
1.99	0.60	1.56	0.27	-10.5	10	3
2.14	0.60	1.63	0.29	-10.5	10	3
2.22	0.60	1.66	0.33	-10.5	10	3
2.23	0.61	1.71	0.30	-10.5	10	3

Sample calculation

$$E \text{ (dB } \mu\text{V/m)} = U \text{ (dB } \mu\text{V)} + \text{AF (dB 1/m)} + \text{Corr. (dB)}$$

U = Receiver reading

AF = Antenna factor

Corr. = sum of single correction factors of used cables, switch unit, distance correction, amplifier (if applicable)

distance correction = $-20 * \text{LOG} (d_{Limit} / d_{used})$

Linear interpolation will be used for frequencies in between the values in the table.

Tables show an extract of values.

7.4 ANTENNA R&S HF907 (1 GHZ – 18 GHZ)

Frequency	AF R&S HF907	Corr.
MHz	dB (1/m)	dB
1000	24.4	-19.4
2000	28.5	-17.4
3000	31.0	-16.1
4000	33.1	-14.7
5000	34.4	-13.7
6000	34.7	-12.7
7000	35.6	-11.0

cable loss 1 (relay + cable inside chamber)	cable loss 2 (outside chamber)	cable loss 3 (switch unit, attenuator & pre-amp)	cable loss 4 (to receiver)		
dB	dB	dB	dB		
0.99	0.31	-21.51	0.79		
1.44	0.44	-20.63	1.38		
1.87	0.53	-19.85	1.33		
2.41	0.67	-19.13	1.31		
2.78	0.86	-18.71	1.40		
2.74	0.90	-17.83	1.47		
2.82	0.86	-16.19	1.46		

Frequency	AF R&S HF907	Corr.
MHz	dB (1/m)	dB
3000	31.0	-23.4
4000	33.1	-23.3
5000	34.4	-21.7
6000	34.7	-21.2
7000	35.6	-19.8

cable loss 1 (relay inside chamber)	cable loss 2 (inside chamber)	cable loss 3 (outside chamber)	cable loss 4 (switch unit, attenuator & pre-amp)	cable loss 5 (to receiver)	used for FCC 15.247
dB	dB	dB	dB	dB	
0.47	1.87	0.53	-27.58	1.33	
0.56	2.41	0.67	-28.23	1.31	
0.61	2.78	0.86	-27.35	1.40	
0.58	2.74	0.90	-26.89	1.47	
0.66	2.82	0.86	-25.58	1.46	

Frequency	AF R&S HF907	Corr.
MHz	dB (1/m)	dB
7000	35.6	-57.3
8000	36.3	-56.3
9000	37.1	-55.3
10000	37.5	-56.2
11000	37.5	-55.3
12000	37.6	-53.7
13000	38.2	-53.5
14000	39.9	-56.3
15000	40.9	-54.1
16000	41.3	-54.1
17000	42.8	-54.4
18000	44.2	-54.7

cable loss 1 (relay inside chamber)	cable loss 2 (High Pass)	cable loss 3 (pre-amp)	cable loss 4 (inside chamber)	cable loss 5 (outside chamber)	cable loss 6 (to receiver)
dB	dB	dB	dB	dB	dB
0.56	1.28	-62.72	2.66	0.94	1.46
0.69	0.71	-61.49	2.84	1.00	1.53
0.68	0.65	-60.80	3.06	1.09	1.60
0.70	0.54	-61.91	3.28	1.20	1.67
0.80	0.61	-61.40	3.43	1.27	1.70
0.84	0.42	-59.70	3.53	1.26	1.73
0.83	0.44	-59.81	3.75	1.32	1.83
0.91	0.53	-63.03	3.91	1.40	1.77
0.98	0.54	-61.05	4.02	1.44	1.83
1.23	0.49	-61.51	4.17	1.51	1.85
1.36	0.76	-62.36	4.34	1.53	2.00
1.70	0.53	-62.88	4.41	1.55	1.91

Sample calculation

$$E \text{ (dB } \mu\text{V/m)} = U \text{ (dB } \mu\text{V)} + \text{AF (dB 1/m)} + \text{Corr. (dB)}$$

U = Receiver reading

AF = Antenna factor

Corr. = sum of single correction factors of used cables, switch unit, distance correction, amplifier (if applicable)

Linear interpolation will be used for frequencies in between the values in the table.

Tables show an extract of values.

7.5 ANTENNA EMCO 3160-09 (18 GHZ – 26.5 GHZ)

Frequency MHz	AF EMCO 3160-09 dB (1/m)	Corr. dB	cable loss 1 (inside chamber) dB	cable loss 2 (pre- amp) dB	cable loss 3 (inside chamber) dB	cable loss 4 (switch unit) dB	cable loss 5 (to receiver) dB
18000	40.2	-23.5	0.72	-35.85	6.20	2.81	2.65
18500	40.2	-23.2	0.69	-35.71	6.46	2.76	2.59
19000	40.2	-22.0	0.76	-35.44	6.69	3.15	2.79
19500	40.3	-21.3	0.74	-35.07	7.04	3.11	2.91
20000	40.3	-20.3	0.72	-34.49	7.30	3.07	3.05
20500	40.3	-19.9	0.78	-34.46	7.48	3.12	3.15
21000	40.3	-19.1	0.87	-34.07	7.61	3.20	3.33
21500	40.3	-19.1	0.90	-33.96	7.47	3.28	3.19
22000	40.3	-18.7	0.89	-33.57	7.34	3.35	3.28
22500	40.4	-19.0	0.87	-33.66	7.06	3.75	2.94
23000	40.4	-19.5	0.88	-33.75	6.92	3.77	2.70
23500	40.4	-19.3	0.90	-33.35	6.99	3.52	2.66
24000	40.4	-19.8	0.88	-33.99	6.88	3.88	2.58
24500	40.4	-19.5	0.91	-33.89	7.01	3.93	2.51
25000	40.4	-19.3	0.88	-33.00	6.72	3.96	2.14
25500	40.5	-20.4	0.89	-34.07	6.90	3.66	2.22
26000	40.5	-21.3	0.86	-35.11	7.02	3.69	2.28
26500	40.5	-21.1	0.90	-35.20	7.15	3.91	2.36

Sample calculation

$$E \text{ (dB } \mu\text{V/m)} = U \text{ (dB } \mu\text{V)} + \text{AF (dB 1/m)} + \text{Corr. (dB)}$$

U = Receiver reading

AF = Antenna factor

Corr. = sum of single correction factors of used cables, switch unit, distance correction, amplifier (if applicable)

Linear interpolation will be used for frequencies in between the values in the table.

Table shows an extract of values.

7.6 ANTENNA EMCO 3160-10 (26.5 GHZ – 40 GHZ)

Frequency GHz	AF EMCO 3160-10 dB (1/m)	Corr. dB	cable loss 1 (inside chamber) dB	cable loss 2 (outside chamber) dB	cable loss 3 (switch unit) dB	cable loss 4 (to receiver) dB	distance corr. (-20 dB/ decade) dB	d _{Limit} (meas. distance (limit) m	d _{used} (meas. distance (used) m
26.5	43.4	-11.2	4.4				-9.5	3	1.0
27.0	43.4	-11.2	4.4				-9.5	3	1.0
28.0	43.4	-11.1	4.5				-9.5	3	1.0
29.0	43.5	-11.0	4.6				-9.5	3	1.0
30.0	43.5	-10.9	4.7				-9.5	3	1.0
31.0	43.5	-10.8	4.7				-9.5	3	1.0
32.0	43.5	-10.7	4.8				-9.5	3	1.0
33.0	43.6	-10.7	4.9				-9.5	3	1.0
34.0	43.6	-10.6	5.0				-9.5	3	1.0
35.0	43.6	-10.5	5.1				-9.5	3	1.0
36.0	43.6	-10.4	5.1				-9.5	3	1.0
37.0	43.7	-10.3	5.2				-9.5	3	1.0
38.0	43.7	-10.2	5.3				-9.5	3	1.0
39.0	43.7	-10.2	5.4				-9.5	3	1.0
40.0	43.8	-10.1	5.5				-9.5	3	1.0

Sample calculation

$$E \text{ (dB } \mu\text{V/m)} = U \text{ (dB } \mu\text{V)} + \text{AF (dB 1/m)} + \text{Corr. (dB)}$$

U = Receiver reading

AF = Antenna factor

Corr. = sum of single correction factors of used cables, switch unit, distance correction, amplifier (if applicable)

Linear interpolation will be used for frequencies in between the values in the table.

distance correction = $-20 * \text{LOG} (d_{\text{Limit}} / d_{\text{used}})$

Linear interpolation will be used for frequencies in between the values in the table.

Table shows an extract of values.

8 MEASUREMENT UNCERTAINTIES

Test Case	Parameter	Uncertainty
AC Power Line	Power	± 3.4 dB
Field Strength of spurious radiation	Power	± 5.5 dB
6 dB / 26 dB / 99% Bandwidth	Power Frequency	± 2.9 dB ± 11.2 kHz
Conducted Output Power	Power	± 2.2 dB
Band Edge Compliance	Power Frequency	± 2.2 dB ± 11.2 kHz
Frequency Stability	Frequency	± 25 Hz
Power Spectral Density	Power	± 2.2 dB

The measurement uncertainties for all parameters are calculated with an expansion factor (coverage factor) $k = 1.96$. This means, that the true value is in the corresponding interval with a probability of 95 %.

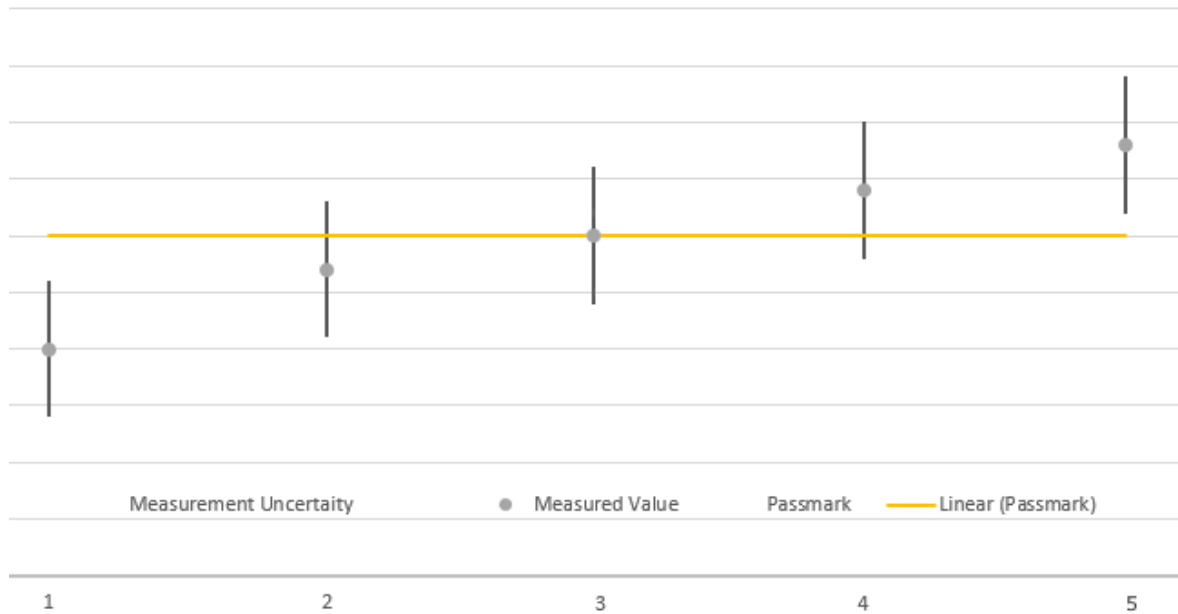

The verdicts in this test report are given according the above diagram:

Case	Measured Value	Uncertainty Range	Verdict
1	below pass mark	below pass mark	Passed
2	below pass mark	within pass mark	Passed
3	on pass mark	within pass mark	Passed
4	above pass mark	within pass mark	Failed
5	above pass mark	above pass mark	Failed

That means, the laboratory applies, as decision rule (see ISO/IEC 17025:2017), the so-called shared risk principle.



9 PHOTO REPORT

Please see separate photo report.

*****END OF TEST REPORT*****