

FCC Test Report

FCC ID : XNAWPM06
Equipment : Withings BPM Connect Pro
Model No. : WPM06
Brand Name : Withings
Applicant : Withings SA
Address : 2 rue Maurice Hartmann
92130 Issy-Les-Moulineaux
France
Standard : 47 CFR FCC Part 15.247
Received Date : Mar. 31, 2021
Tested Date : Apr. 19 ~ Apr. 27, 2021

We, International Certification Corporation, would like to declare that the tested sample has been evaluated and in compliance with the requirement of the above standards. The test results contained in this report refer exclusively to the product. It may be duplicated completely for legal use with the approval of the applicant. It shall not be reproduced except in full without the written approval of our laboratory.

Reviewed by:



Along Chen / Assistant Manager

Approved by:



Gary Chang / Manager



Table of Contents

1	GENERAL DESCRIPTION	5
1.1	Information.....	5
1.2	Local Support Equipment List	7
1.3	Test Setup Chart	7
1.4	The Equipment List	8
1.5	Test Standards	9
1.6	Reference Guidance	9
1.7	Deviation from Test Standard and Measurement Procedure.....	9
1.8	Measurement Uncertainty	9
2	TEST CONFIGURATION.....	10
2.1	Testing Facility	10
2.2	The Worst Test Modes and Channel Details	10
3	TRANSMITTER TEST RESULTS	11
3.1	Conducted Emissions.....	11
3.2	6dB and Occupied Bandwidth.....	14
3.3	RF Output Power.....	16
3.4	Power Spectral Density	19
3.5	Unwanted Emissions into Restricted Frequency Bands	24
3.6	Emissions in Non-Restricted Frequency Bands.....	48
4	TEST LABORATORY INFORMATION	52

Release Record

Report No.	Version	Description	Issued Date
FR133101AC	Rev. 01	Initial issue	May 11, 2021

Summary of Test Results

FCC Rules	Test Items	Measured	Result
15.207	Conducted Emissions	[dBuV]: 0.788MHz 29.30 (Margin -16.70dB) - AV	Pass
15.247(d) 15.209	Radiated Emissions	[dBuV/m at 3m]: 4924.00MHz 52.95 (Margin -1.05dB) - AV	Pass
15.247(b)(3)	Maximum Output Power	Max Power [dBm]: 21.48	Pass
15.247(a)(2)	6dB Bandwidth	Meet the requirement of limit	Pass
15.247(e)	Power Spectral Density	Meet the requirement of limit	Pass
15.203	Antenna Requirement	Meet the requirement of limit	Pass

Declaration of Conformity:

The test results with all measurement uncertainty excluded are presented in accordance with the regulation limits or requirements declared by manufacturers.

Comments and Explanations:

The declared of product specification for EUT presented in the report are provided by the manufacturer, and the manufacturer takes all the responsibilities for the accuracy of product specification.

1 General Description

1.1 Information

1.1.1 Specification of the Equipment under Test (EUT)

RF General Information					
Frequency Range (MHz)	IEEE Std. 802.11	Ch. Freq. (MHz)	Channel Number	Transmit Chains (N _{TX})	Data Rate / MCS
2400-2483.5	b	2412-2462	1-11 [11]	1	1-11 Mbps
2400-2483.5	g	2412-2462	1-11 [11]	1	6-54 Mbps
2400-2483.5	n (HT20)	2412-2462	1-11 [11]	1	MCS 0-7

Note 1: RF output power specifies that Maximum Peak Conducted Output Power.
 Note 2: 802.11b uses a combination of DSSS-DBPSK, DQPSK, CCK modulation.
 Note 3: 802.11g/n uses a combination of OFDM-BPSK, QPSK, 16QAM, 64QAM modulation.

1.1.2 Antenna Details

Ant. No.	Brand / Model	Type	Connector	Gain (dBi)
1	Brand: BROADCOM Model: BCM9Fractal	PCB	NA	2.8

1.1.3 Power Supply Type of Equipment under Test (EUT)

Power Supply Type	From battery Brand: CEL ; Model: 652265, 1000mAh, 3.7V
--------------------------	---

1.1.4 Accessories

Accessories		
No.	Equipment	Description
1	USB cable	0.58m non-shielded without core

1.1.5 Test Sample Information

MAC Number of Test Sample	Radiated Emission: 0024E4C52360 AC Power Line Conducted Emission: 0024E4C52360 Antenna Port Conducted: 0024E4D3E8BD
----------------------------------	---

1.1.6 Channel List

Channel	Frequency(MHz)
1	2412
2	2417
3	2422
4	2427
5	2432
6	2437
7	2442
8	2447
9	2452
10	2457
11	2462

1.1.7 Test Tool and Duty Cycle

Test Tool	Tera Term, V4.74		
Duty Cycle and Duty Factor	Mode	Duty Cycle (%)	Duty Factor (dB)
	11b	99.32%	0.03
	11g	94.71%	0.24
	HT20	93.85%	0.28

1.1.8 Power Index of Test Tool

Modulation Mode	Test Frequency (MHz)	Power Index
11b	2412	46
11b	2437	44
11b	2462	44
11g	2412	default(-1)
11g	2437	default(-1)
11g	2462	default(-1)
HT20	2412	default(-1)
HT20	2437	default(-1)
HT20	2462	default(-1)

1.2 Local Support Equipment List

Support Equipment List					
No.	Equipment	Brand	Model	FCC ID	Remarks
1	Notebook	DELL	Latitude E5470	DoC	---
2	Fixture	---	---	---	Provided by applicant.

Note: The support notebook and fixture were disconnected from EUT and were removed from test table after sending command from support notebook to control EUT to transmit continuously.

1.3 Test Setup Chart

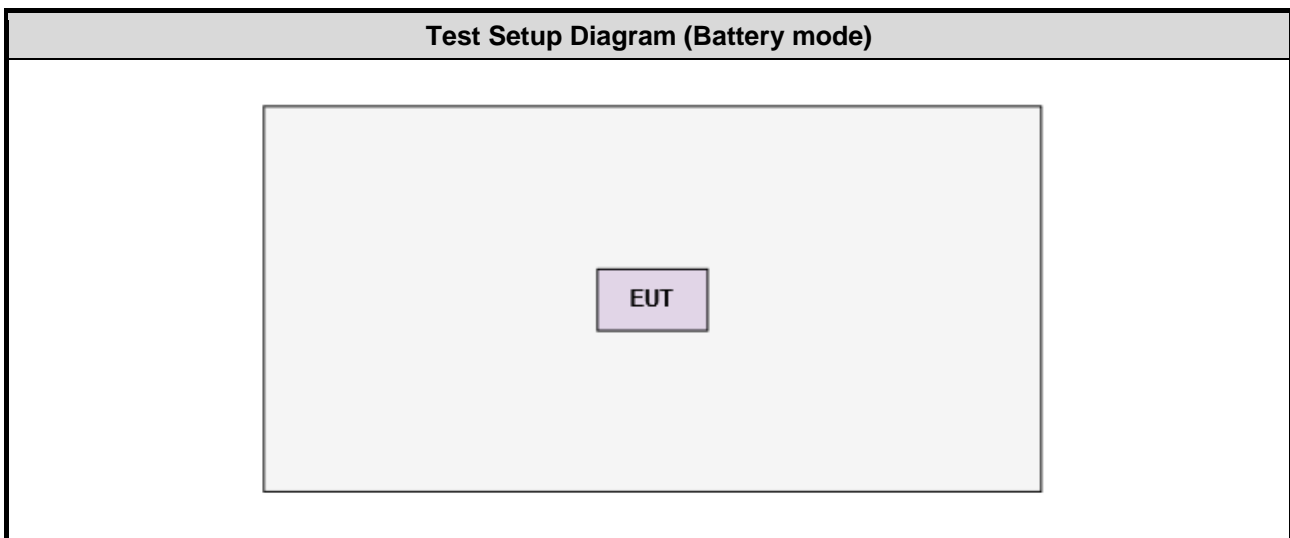
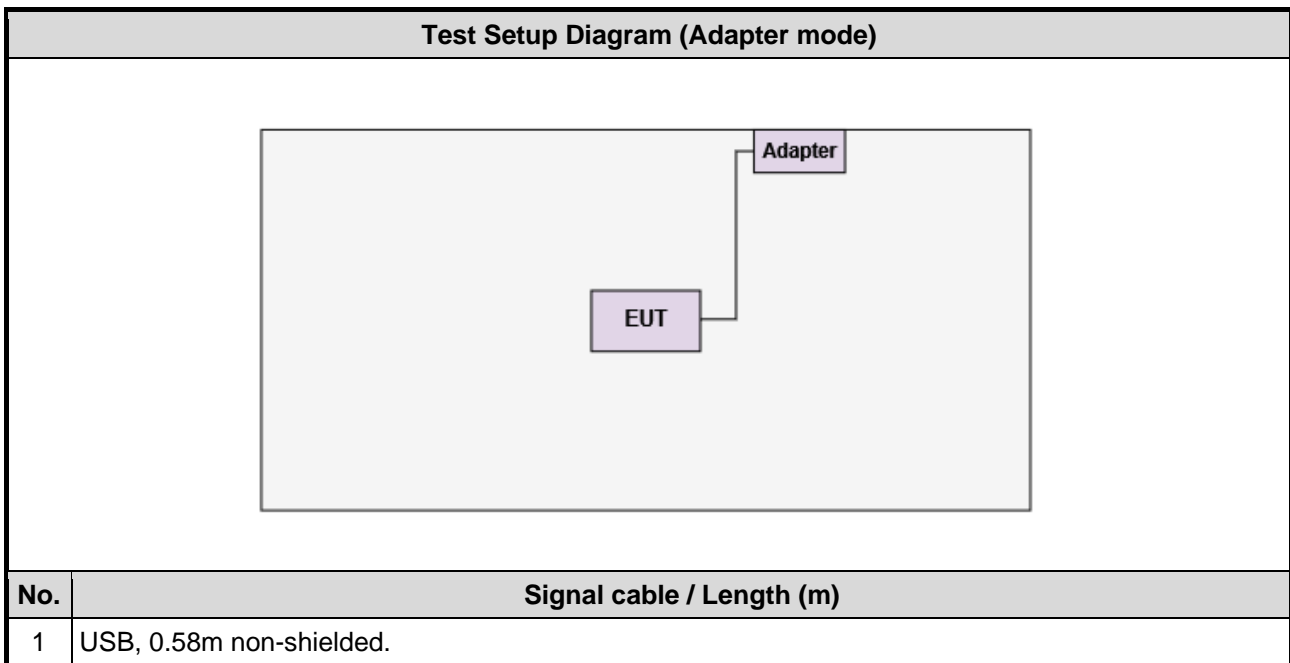

1.4 The Equipment List

Test Item	Conducted Emission				
Test Site	Conduction room 1 / (CO01-WS)				
Tested Date	Apr. 27, 2021				
Instrument	Brand	Model No.	Serial No.	Calibration Date	Calibration Until
Receiver	R&S	ESR3	101658	Feb. 08, 2021	Feb. 07, 2022
LISN	R&S	ENV216	101579	Mar. 17, 2021	Mar. 16, 2022
LISN (Support Unit)	SCHWARZBECK	Schwarzbeck 8127	8127-666	Dec. 29, 2020	Dec. 28, 2021
RF Cable-CON	Woken	CFD200-NL	CFD200-NL-001	Oct. 21, 2020	Oct. 20, 2021
50 ohm terminal (Support Unit)	NA	50	04	Jun. 05, 2020	Jun. 04, 2021
Measurement Software	AUDIX	e3	6.120210k	NA	NA

Note: Calibration Interval of instruments listed above is one year.

Test Item	Radiated Emission				
Test Site	966 chamber1 / (03CH01-WS)				
Tested Date	Apr. 19 ~ Apr. 20, 2021				
Instrument	Brand	Model No.	Serial No.	Calibration Date	Calibration Until
Receiver	R&S	ESR3	101657	Mar. 12, 2021	Mar. 11, 2022
Spectrum Analyzer	R&S	FSV40	101498	Dec. 04, 2020	Dec. 03, 2021
Loop Antenna	R&S	HFH2-Z2	100330	Nov. 17, 2020	Nov. 16, 2021
Bilog Antenna	SCHWARZBECK	VULB9168	VULB9168-522	Jul. 10, 2020	Jul. 09, 2021
Horn Antenna 1G-18G	SCHWARZBECK	BBHA 9120 D	BBHA 9120 D 1096	Dec. 11, 2020	Dec. 10, 2021
Horn Antenna 18G-40G	SCHWARZBECK	BBHA 9170	BBHA 9170517	Nov. 06, 2020	Nov. 05, 2021
Preamplifier	EMC	EMC02325	980225	Jul. 03, 2020	Jul. 02, 2021
Preamplifier	Agilent	83017A	MY39501308	Sep. 26, 2020	Sep. 25, 2021
Preamplifier	EMC	EMC184045B	980192	Jul. 21, 2020	Jul. 20, 2021
Loop Antenna Cable	KOAX KABEL	101354-BW	101354-BW	Oct. 06, 2020	Oct. 05, 2021
LF cable 3M	Woken	CFD400NL-LW	CFD400NL-001	Oct. 06, 2020	Oct. 05, 2021
LF cable 11M	EMC	EMCCFD400-NW-N W-11000	200801	Oct. 06, 2020	Oct. 05, 2021
LF cable 1M	EMC	EMCCFD400-NM-N M-1000	160502	Oct. 06, 2020	Oct. 05, 2021
RF Cable	HUBER+SUHNER	SUCOFLEX104	MY16019/4	Oct. 06, 2020	Oct. 05, 2021
RF Cable	HUBER+SUHNER	SUCOFLEX104	MY16014/4	Oct. 06, 2020	Oct. 05, 2021
Measurement Software	AUDIX	e3	6.120210g	NA	NA

Note: Calibration Interval of instruments listed above is one year.

Test Item	RF Conducted				
Test Site	(TH01-WS)				
Tested Date	Apr. 27, 2021				
Instrument	Brand	Model No.	Serial No.	Calibration Date	Calibration Until
Spectrum Analyzer	R&S	FSV40	101063	Apr. 30, 2020	Apr. 29, 2021
Power Meter	Anritsu	ML2495A	1241002	Nov. 04, 2020	Nov. 03, 2021
Power Sensor	Anritsu	MA2411B	1207366	Nov. 04, 2020	Nov. 03, 2021
Measurement Software	--	SENSE-15247_DTS	V5.10	NA	NA
Note: Calibration Interval of instruments listed above is one year.					

1.5 Test Standards

47 CFR FCC Part 15.247
ANSI C63.10-2013

1.6 Reference Guidance

FCC KDB 558074 D01 15.247 Meas Guidance v05r02

1.7 Deviation from Test Standard and Measurement Procedure

None

1.8 Measurement Uncertainty

The measurement uncertainties given below are based on a 95% confidence level (based on a coverage factor (k=2)).

Measurement Uncertainty	
Parameters	Uncertainty
Bandwidth	±34.130 Hz
Conducted power	±0.808 dB
Power density	±0.583 dB
Conducted emission	±2.715 dB
AC conducted emission	±2.92 dB
Radiated emission ≤ 1GHz	±3.41 dB
Radiated emission > 1GHz	±4.59 dB

2 Test Configuration

2.1 Testing Facility

Test Laboratory	International Certification Corporation
Test Site	CO01-WS, 03CH01-WS, TH01-WS
Address of Test Site	No.3-1, Lane 6, Wen San 3rd St., Kwei Shan Dist., Tao Yuan City 33381, Taiwan (R.O.C.)

- FCC Designation No.: TW2732
- FCC site registration No.: 181692
- ISED#: 10807A
- CAB identifier: TW2732

2.2 The Worst Test Modes and Channel Details

Test item	Modulation Mode	Test Frequency (MHz)	Data Rate	Test Configuration
Conducted Emissions	11g	2462	6 Mbps	2
Radiated Emissions ≤1GHz	11g	2462	6 Mbps	1, 2
Radiated Emissions >1GHz				
Maximum Output Power	11b	2412 / 2437 / 2462	1 Mbps	1
6dB bandwidth	11g	2412 / 2437 / 2462	6 Mbps	
Power spectral density	HT20	2412 / 2437 / 2462	MCS 0	

NOTE:

1. The EUT was pretested with 3 orientations placed on the table for the radiated emission measurement – X, Y, and Z-plane. The **Y-plane** results were found as the worst case and were shown in this report.
2. The device can be operated under battery mode and adapter mode. Each mode was selected for related test items as below configuration.
 Configuration 1: Battery mode
 Configuration 2: Adapter mode

3 Transmitter Test Results

3.1 Conducted Emissions

3.1.1 Limit of Conducted Emissions

Conducted Emissions Limit		
Frequency Emission (MHz)	Quasi-Peak	Average
0.15-0.5	66 - 56 *	56 - 46 *
0.5-5	56	46
5-30	60	50

Note 1: * Decreases with the logarithm of the frequency.

3.1.2 Test Procedures

1. The device is placed on a test table, raised 80 cm above the reference ground plane. The vertical conducting plane is located 40 cm to the rear of the device.
2. The device is connected to line impedance stabilization network (LISN) and other accessories are connected to other LISN. Measured levels of AC power line conducted emission are across the 50 Ω LISN port.
3. AC conducted emission measurements is made over frequency range from 150 kHz to 30 MHz.
4. This measurement was performed with AC 120V / 60Hz.

3.1.3 Test Setup



- Note: 1. Support units were connected to second LISN.
 2. Both of LISNs (AMN) are 80 cm from EUT and at least 80 cm from other units and other metal planes

3.1.4 Test Result of Conducted Emissions

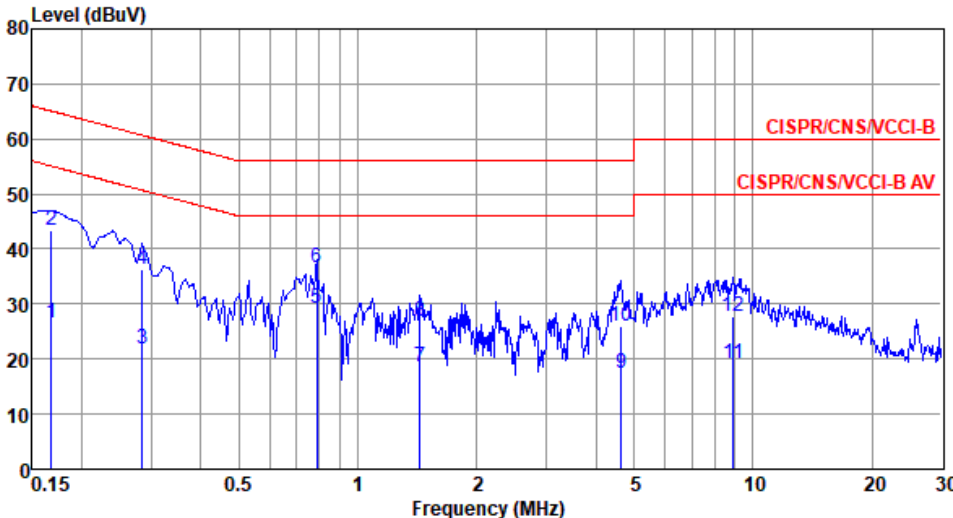
Modulation	11g	Test Freq. (MHz)	2462																																																																																																																					
Power Phase	Line																																																																																																																							
<p>Test by : Alex Tsai Temperature: 22°C Humidity: 60%</p>																																																																																																																								
																																																																																																																								
<table border="1"> <thead> <tr> <th></th> <th>Freq MHz</th> <th>Level dBuV</th> <th>Limit Line dBuV</th> <th>Over Limit dB</th> <th>Read Level dBuV</th> <th>Factor dB</th> <th>Cable loss dB</th> <th>Remark</th> </tr> </thead> <tbody> <tr> <td>1</td> <td>0.168</td> <td>26.56</td> <td>55.08</td> <td>-28.52</td> <td>16.68</td> <td>9.83</td> <td>0.05</td> <td>Average</td> </tr> <tr> <td>2</td> <td>0.168</td> <td>43.42</td> <td>65.08</td> <td>-21.66</td> <td>33.54</td> <td>9.83</td> <td>0.05</td> <td>QP</td> </tr> <tr> <td>3</td> <td>0.285</td> <td>21.95</td> <td>50.68</td> <td>-28.73</td> <td>12.01</td> <td>9.87</td> <td>0.07</td> <td>Average</td> </tr> <tr> <td>4</td> <td>0.285</td> <td>36.44</td> <td>60.68</td> <td>-24.24</td> <td>26.50</td> <td>9.87</td> <td>0.07</td> <td>QP</td> </tr> <tr> <td>5*</td> <td>0.788</td> <td>29.30</td> <td>46.00</td> <td>-16.70</td> <td>19.23</td> <td>9.96</td> <td>0.11</td> <td>Average</td> </tr> <tr> <td>6</td> <td>0.788</td> <td>36.47</td> <td>56.00</td> <td>-19.53</td> <td>26.40</td> <td>9.96</td> <td>0.11</td> <td>QP</td> </tr> <tr> <td>7</td> <td>1.433</td> <td>18.58</td> <td>46.00</td> <td>-27.42</td> <td>8.43</td> <td>10.00</td> <td>0.15</td> <td>Average</td> </tr> <tr> <td>8</td> <td>1.433</td> <td>27.00</td> <td>56.00</td> <td>-29.00</td> <td>16.85</td> <td>10.00</td> <td>0.15</td> <td>QP</td> </tr> <tr> <td>9</td> <td>4.647</td> <td>17.33</td> <td>46.00</td> <td>-28.67</td> <td>6.97</td> <td>10.05</td> <td>0.31</td> <td>Average</td> </tr> <tr> <td>10</td> <td>4.647</td> <td>26.04</td> <td>56.00</td> <td>-29.96</td> <td>15.68</td> <td>10.05</td> <td>0.31</td> <td>QP</td> </tr> <tr> <td>11</td> <td>8.916</td> <td>19.17</td> <td>50.00</td> <td>-30.83</td> <td>8.68</td> <td>10.10</td> <td>0.39</td> <td>Average</td> </tr> <tr> <td>12</td> <td>8.916</td> <td>27.79</td> <td>60.00</td> <td>-32.21</td> <td>17.30</td> <td>10.10</td> <td>0.39</td> <td>QP</td> </tr> </tbody> </table>					Freq MHz	Level dBuV	Limit Line dBuV	Over Limit dB	Read Level dBuV	Factor dB	Cable loss dB	Remark	1	0.168	26.56	55.08	-28.52	16.68	9.83	0.05	Average	2	0.168	43.42	65.08	-21.66	33.54	9.83	0.05	QP	3	0.285	21.95	50.68	-28.73	12.01	9.87	0.07	Average	4	0.285	36.44	60.68	-24.24	26.50	9.87	0.07	QP	5*	0.788	29.30	46.00	-16.70	19.23	9.96	0.11	Average	6	0.788	36.47	56.00	-19.53	26.40	9.96	0.11	QP	7	1.433	18.58	46.00	-27.42	8.43	10.00	0.15	Average	8	1.433	27.00	56.00	-29.00	16.85	10.00	0.15	QP	9	4.647	17.33	46.00	-28.67	6.97	10.05	0.31	Average	10	4.647	26.04	56.00	-29.96	15.68	10.05	0.31	QP	11	8.916	19.17	50.00	-30.83	8.68	10.10	0.39	Average	12	8.916	27.79	60.00	-32.21	17.30	10.10	0.39	QP
	Freq MHz	Level dBuV	Limit Line dBuV	Over Limit dB	Read Level dBuV	Factor dB	Cable loss dB	Remark																																																																																																																
1	0.168	26.56	55.08	-28.52	16.68	9.83	0.05	Average																																																																																																																
2	0.168	43.42	65.08	-21.66	33.54	9.83	0.05	QP																																																																																																																
3	0.285	21.95	50.68	-28.73	12.01	9.87	0.07	Average																																																																																																																
4	0.285	36.44	60.68	-24.24	26.50	9.87	0.07	QP																																																																																																																
5*	0.788	29.30	46.00	-16.70	19.23	9.96	0.11	Average																																																																																																																
6	0.788	36.47	56.00	-19.53	26.40	9.96	0.11	QP																																																																																																																
7	1.433	18.58	46.00	-27.42	8.43	10.00	0.15	Average																																																																																																																
8	1.433	27.00	56.00	-29.00	16.85	10.00	0.15	QP																																																																																																																
9	4.647	17.33	46.00	-28.67	6.97	10.05	0.31	Average																																																																																																																
10	4.647	26.04	56.00	-29.96	15.68	10.05	0.31	QP																																																																																																																
11	8.916	19.17	50.00	-30.83	8.68	10.10	0.39	Average																																																																																																																
12	8.916	27.79	60.00	-32.21	17.30	10.10	0.39	QP																																																																																																																
<p>Note 1: Level (dBuV) = Read Level (dBuV) + LISN Factor (dB) + Cable Loss (dB). Note 2: Over Limit (dB) = Level (dBuV) – Limit Line (dBuV).</p>																																																																																																																								

Modulation	11g	Test Freq. (MHz)	2462
Power Phase	Neutral		

Test by : Alex Tsai Temperature: 22°C Humidity: 60%

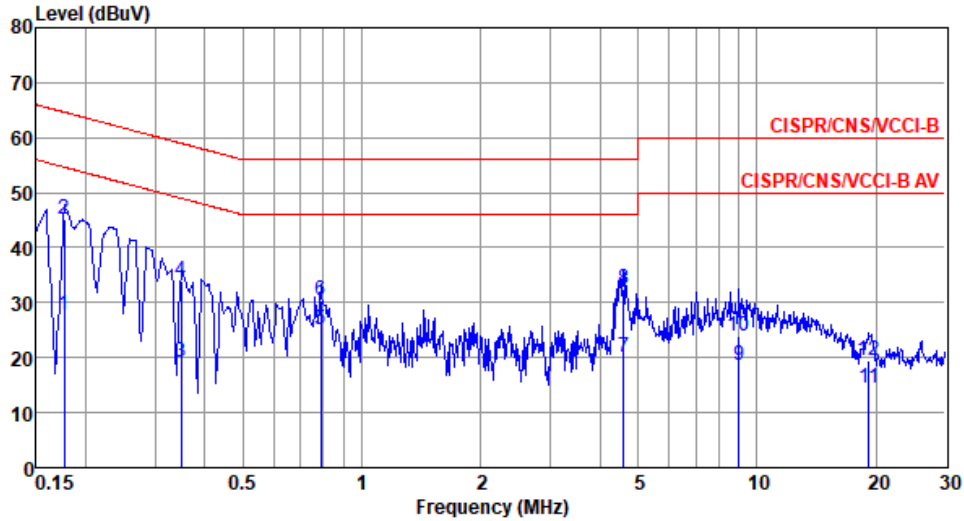

	Freq MHz	Level dBuV	Limit Line dBuV	Over Limit dB	Read Level dBuV	Factor dB	Cable loss dB	Remark
1	0.177	27.69	54.64	-26.95	17.80	9.83	0.06	Average
2*	0.177	45.15	64.64	-19.49	35.26	9.83	0.06	QP
3	0.348	19.32	49.00	-29.68	9.39	9.85	0.08	Average
4	0.348	33.85	59.00	-25.15	23.92	9.85	0.08	QP
5	0.788	25.09	46.00	-20.91	15.11	9.87	0.11	Average
6	0.788	30.51	56.00	-25.49	20.53	9.87	0.11	QP
7	4.598	20.07	46.00	-25.93	9.78	9.98	0.31	Average
8	4.598	32.59	56.00	-23.41	22.30	9.98	0.31	QP
9	9.011	18.67	50.00	-31.33	8.21	10.07	0.39	Average
10	9.011	23.87	60.00	-36.13	13.41	10.07	0.39	QP
11	19.224	14.52	50.00	-35.48	3.55	10.31	0.66	Average
12	19.224	19.43	60.00	-40.57	8.46	10.31	0.66	QP

Note 1: Level (dBuV) = Read Level (dBuV) + LISN Factor (dB) + Cable Loss (dB).
 Note 2: Over Limit (dB) = Level (dBuV) – Limit Line (dBuV).

3.2 6dB and Occupied Bandwidth

3.2.1 Limit of 6dB Bandwidth

The minimum 6dB bandwidth shall be at least 500 kHz.

3.2.2 Test Procedures

6dB Bandwidth

1. Set resolution bandwidth (RBW) = 100 kHz, Video bandwidth = 300 kHz.
2. Detector = Peak, Trace mode = max hold.
3. Sweep = auto couple, Allow the trace to stabilize.
4. Measure the maximum width of the emission that is constrained by the frequencies associated with the two outermost amplitude points (upper and lower) that are attenuated by 6dB relative to the maximum level measured in the fundamental emission.

Occupied Bandwidth

1. Set resolution bandwidth (RBW) = 1% ~ 5 % of OBW, Video bandwidth = 3 x RBW
2. Detector = Sample, Trace mode = max hold.
3. Sweep = auto couple, Allow the trace to stabilize.
4. Use the OBW measurement function of spectrum analyzer to measure the occupied bandwidth.

3.2.3 Test Setup

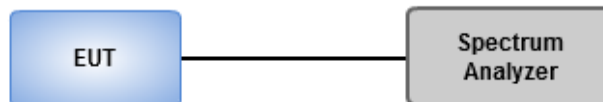

3.2.4 Test Result of 6dB and Occupied Bandwidth

Ambient Condition	23°C / 63%	Tested By	BRAD WU
--------------------------	------------	------------------	---------

Summary

Mode	Max-N dB (Hz)	Max-OBW (Hz)	ITU-Code	Min-N dB (Hz)	Min-OBW (Hz)
2.4-2.4835GHz	-	-	-	-	-
802.11b_Nss1,(1Mbps)_1TX	9.493M	14.038M	14M0G1D	7.609M	13.965M
802.11g_Nss1,(6Mbps)_1TX	15.29M	16.353M	16M4D1D	13.841M	16.353M
802.11n HT20_Nss1,(MCS0)_1TX	15.072M	17.511M	17M5D1D	13.841M	17.511M

Max-N dB = Maximum 6dB down bandwidth; **Max-OBW** = Maximum 99% occupied bandwidth;
Min-N dB = Minimum 6dB down bandwidth; **Min-OBW** = Minimum 99% occupied bandwidth;

Result

Mode	Result	Limit (Hz)	Port 1-N dB (Hz)	Port 1-OBW (Hz)
802.11b_Nss1,(1Mbps)_1TX	-	-	-	-
2412MHz	Pass	500k	8.551M	14.038M
2437MHz	Pass	500k	7.609M	13.965M
2462MHz	Pass	500k	9.493M	13.965M
802.11g_Nss1,(6Mbps)_1TX	-	-	-	-
2412MHz	Pass	500k	13.841M	16.353M
2437MHz	Pass	500k	15.072M	16.353M
2462MHz	Pass	500k	15.29M	16.353M
802.11n HT20_Nss1,(MCS0)_1TX	-	-	-	-
2412MHz	Pass	500k	15.072M	17.511M
2437MHz	Pass	500k	13.841M	17.511M
2462MHz	Pass	500k	15.072M	17.511M

Port X-N dB = Port X 6dB down bandwidth; **Port X-OBW** = Port X 99% occupied bandwidth;

3.3 RF Output Power

3.3.1 Limit of RF Output Power

Conducted power shall not exceed 1Watt.

Antenna gain $\leq 6\text{dBi}$, no any corresponding reduction is in output power limit.

3.3.2 Test Procedures

A broadband RF power meter is used for output power measurement. The video bandwidth of power meter is greater than DTS bandwidth of EUT. If duty cycle of test signal is not 100 %, trigger and gating function of power meter will be enabled to capture transmission burst for measuring output power.

3.3.3 Test Setup

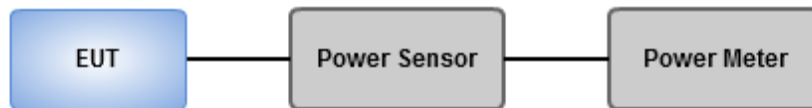

3.3.4 Test Result of Maximum Output Power

Ambient Condition	23°C / 63%	Tested By	BRAD WU
--------------------------	------------	------------------	---------

Summary of Peak Conducted Output Power

Mode	Total Power (dBm)	Total Power (W)
2.4-2.4835GHz	-	-
802.11b_Nss1,(1Mbps)_1TX	9.93	0.00984
802.11g_Nss1,(6Mbps)_1TX	21.48	0.14060
802.11n HT20_Nss1,(MCS0)_1TX	21.18	0.13122

Result

Mode	Result	DG (dBi)	Port 1 (dBm)	Total Power (dBm)	Power Limit (dBm)	EIRP (dBm)	EIRP Limit (dBm)
802.11b_Nss1,(1Mbps)_1TX	-	-	-	-	-	-	-
2412MHz	Pass	2.80	9.93	9.93	30.00	12.73	36.00
2437MHz	Pass	2.80	9.44	9.44	30.00	12.24	36.00
2462MHz	Pass	2.80	9.06	9.06	30.00	11.86	36.00
802.11g_Nss1,(6Mbps)_1TX	-	-	-	-	-	-	-
2412MHz	Pass	2.80	20.73	20.73	30.00	23.53	36.00
2437MHz	Pass	2.80	21.42	21.42	30.00	24.22	36.00
2462MHz	Pass	2.80	21.48	21.48	30.00	24.28	36.00
802.11n HT20_Nss1,(MCS0)_1TX	-	-	-	-	-	-	-
2412MHz	Pass	2.80	20.55	20.55	30.00	23.35	36.00
2437MHz	Pass	2.80	21.02	21.02	30.00	23.82	36.00
2462MHz	Pass	2.80	21.18	21.18	30.00	23.98	36.00

DG = Directional Gain; **Port X** = Port X output power

Summary of Conducted (Average) Output Power

Mode	Total Power (dBm)	Total Power (W)
2.4-2.4835GHz	-	-
802.11b_Nss1,(1Mbps)_1TX	7.55	0.00569
802.11g_Nss1,(6Mbps)_1TX	12.59	0.01816
802.11n HT20_Nss1,(MCS0)_1TX	11.50	0.01413

Result

Mode	Result	DG (dBi)	Port 1 (dBm)	Total Power (dBm)	Power Limit (dBm)	EIRP (dBm)	EIRP Limit (dBm)
802.11b_Nss1,(1Mbps)_1TX	-	-	-	-	-	-	-
2412MHz	Pass	2.80	7.55	7.55	-	10.35	-
2437MHz	Pass	2.80	6.89	6.89	-	9.69	-
2462MHz	Pass	2.80	6.67	6.67	-	9.47	-
802.11g_Nss1,(6Mbps)_1TX	-	-	-	-	-	-	-
2412MHz	Pass	2.80	12.25	12.25	-	15.05	-
2437MHz	Pass	2.80	12.40	12.40	-	15.20	-
2462MHz	Pass	2.80	12.59	12.59	-	15.39	-
802.11n HT20_Nss1,(MCS0)_1TX	-	-	-	-	-	-	-
2412MHz	Pass	2.80	11.31	11.31	-	14.11	-
2437MHz	Pass	2.80	11.39	11.39	-	14.19	-
2462MHz	Pass	2.80	11.50	11.50	-	14.30	-

DG = Directional Gain; **Port X** = Port X output power

Note : Conducted average output power is for reference only

3.4 Power Spectral Density

3.4.1 Limit of Power Spectral Density

Power spectral density shall not be greater than 8 dBm in any 3 kHz band.

3.4.2 Test Procedures

1. Set the RBW = 3 kHz, VBW = 10 kHz.
2. Detector = Peak, Sweep time = auto couple.
3. Trace mode = max hold, allow trace to fully stabilize.
4. Use the peak marker function to determine the maximum amplitude level.

3.4.3 Test Setup

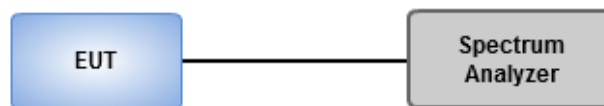

3.4.4 Test Result of Power Spectral Density

Ambient Condition	23°C / 63%	Tested By	BRAD WU
--------------------------	------------	------------------	---------

Summary

Mode	PD (dBm/3kHz)
2.4-2.4835GHz	-
802.11b_Nss1,(1Mbps)_1TX	-16.19
802.11g_Nss1,(6Mbps)_1TX	-12.63
802.11n HT20_Nss1,(MCS0)_1TX	-13.65

Result

Mode	Result	DG (dBi)	Port 1 (dBm/3kHz)	PD (dBm/3kHz)	PD Limit (dBm/3kHz)
802.11b_Nss1,(1Mbps)_1TX	-	-	-	-	-
2412MHz	Pass	2.80	-16.19	-16.19	8.00
2437MHz	Pass	2.80	-16.25	-16.25	8.00
2462MHz	Pass	2.80	-16.97	-16.97	8.00
802.11g_Nss1,(6Mbps)_1TX	-	-	-	-	-
2412MHz	Pass	2.80	-12.63	-12.63	8.00
2437MHz	Pass	2.80	-13.60	-13.60	8.00
2462MHz	Pass	2.80	-13.97	-13.97	8.00
802.11n HT20_Nss1,(MCS0)_1TX	-	-	-	-	-
2412MHz	Pass	2.80	-14.36	-14.36	8.00
2437MHz	Pass	2.80	-13.65	-13.65	8.00
2462MHz	Pass	2.80	-14.31	-14.31	8.00

DG = Directional Gain;

PD = Maximum power density; **Port X** = Port X power density;

802.11b_Nss1,(1Mbps)_1TX

PSD

2412MHz

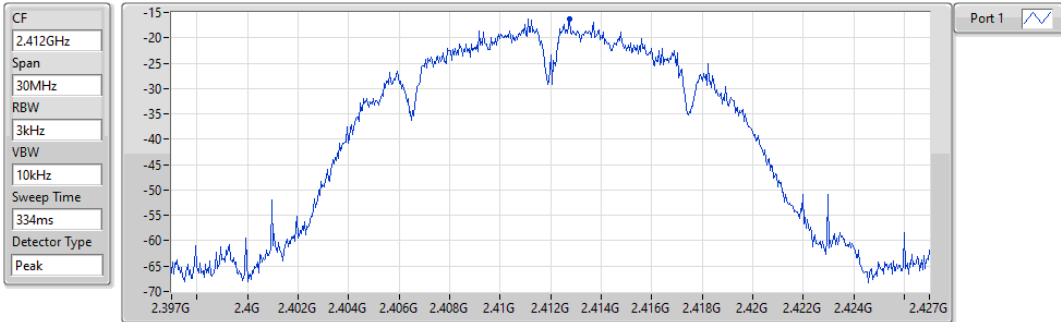

Sum	PD	Port 1
(dBm/3kHz)	(dBm/3kHz)	(dBm/3kHz)
-16.19	-16.19	-16.19

802.11b_Nss1,(1Mbps)_1TX

PSD

2437MHz

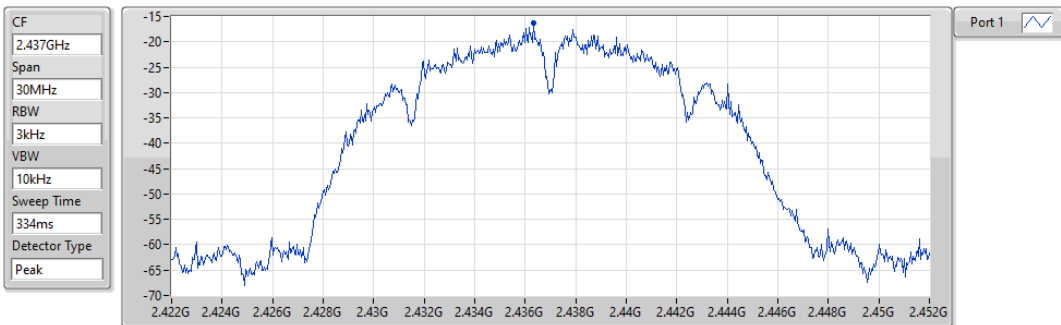

Sum	PD	Port 1
(dBm/3kHz)	(dBm/3kHz)	(dBm/3kHz)
-16.25	-16.25	-16.25

802.11b_Nss1,(1Mbps)_1TX

PSD

2462MHz

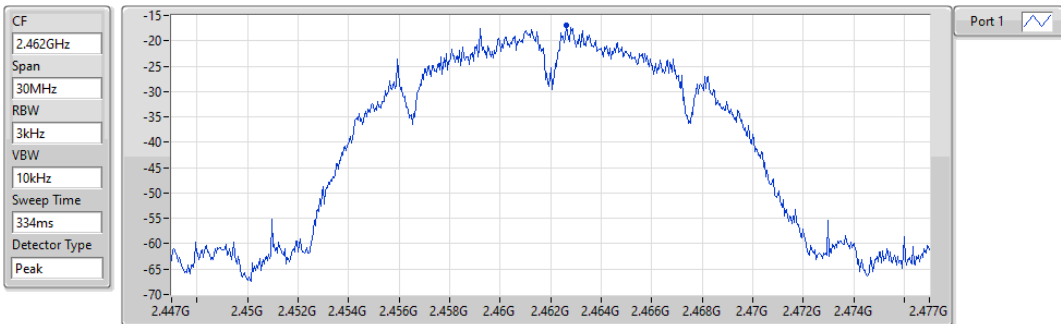

Sum	PD	Port 1
(dBm/3kHz)	(dBm/3kHz)	(dBm/3kHz)
-16.97	-16.97	-16.97

802.11g_Nss1,(6Mbps)_1TX

PSD

2412MHz

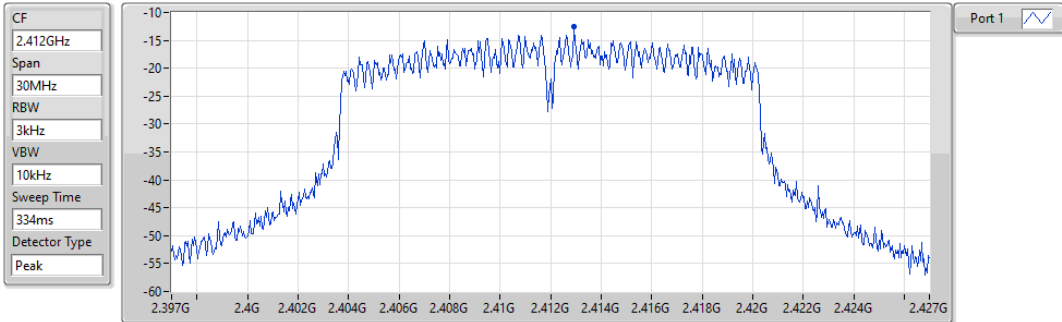

Sum	PD	Port 1
(dBm/100kHz)	(dBm/100kHz)	(dBm/100kHz)
-12.63	-12.63	-12.63

802.11g_Nss1,(6Mbps)_1TX

PSD

2437MHz

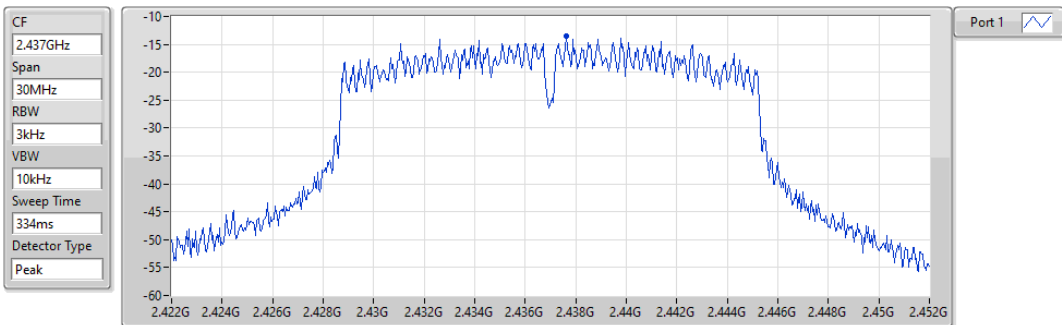

Sum	PD	Port 1
(dBm/100kHz)	(dBm/100kHz)	(dBm/100kHz)
-13.60	-13.60	-13.60

802.11g_Nss1,(6Mbps)_1TX

PSD

2462MHz

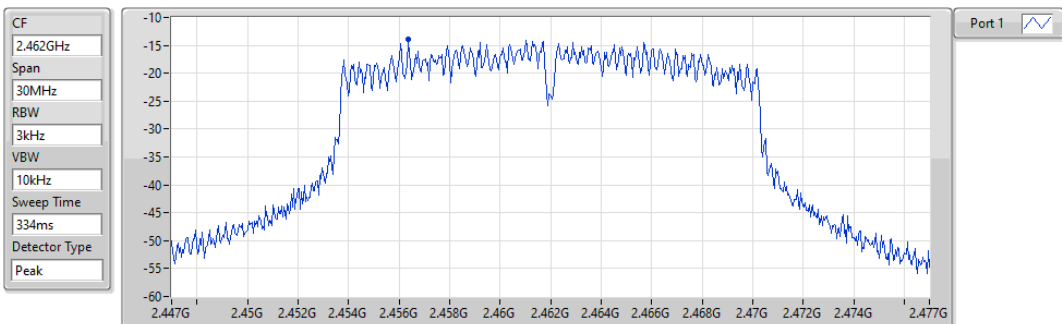

Sum	PD	Port 1
(dBm/100kHz)	(dBm/100kHz)	(dBm/100kHz)
-13.97	-13.97	-13.97

802.11n HT20_Nss1,(MCS0)_1TX

PSD

2412MHz

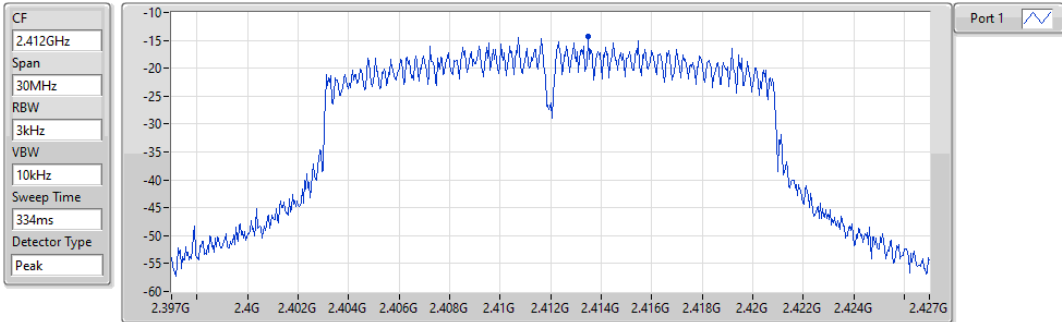

Sum	PD	Port 1
(dBm/100kHz)	(dBm/100kHz)	(dBm/100kHz)
-14.36	-14.36	-14.36

802.11n HT20_Nss1,(MCS0)_1TX

PSD

2437MHz

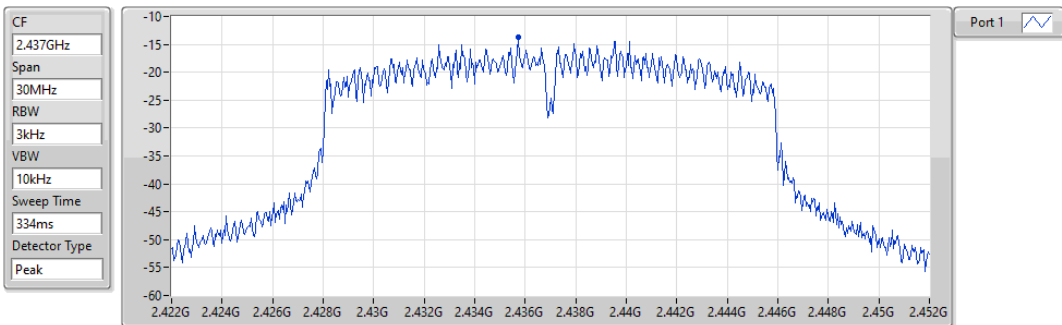

Sum	PD	Port 1
(dBm/100kHz)	(dBm/100kHz)	(dBm/100kHz)
-13.65	-13.65	-13.65

802.11n HT20_Nss1,(MCS0)_1TX

PSD

2462MHz

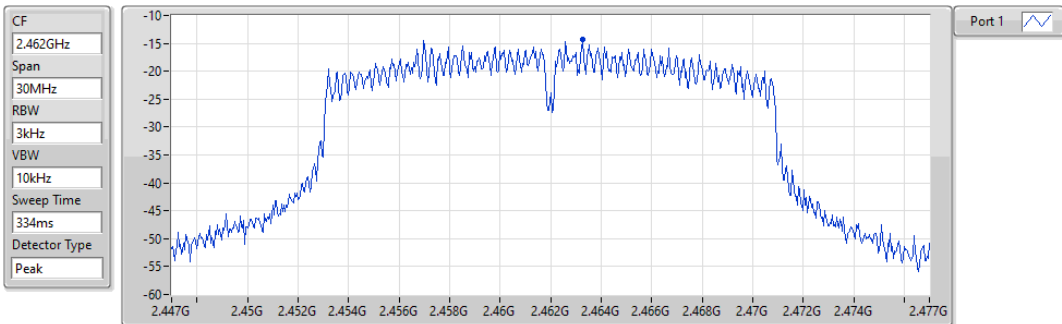

Sum	PD	Port 1
(dBm/100kHz)	(dBm/100kHz)	(dBm/100kHz)
-14.31	-14.31	-14.31

3.5 Unwanted Emissions into Restricted Frequency Bands

3.5.1 Limit of Unwanted Emissions into Restricted Frequency Bands

Restricted Band Emissions Limit			
Frequency Range (MHz)	Field Strength (uV/m)	Field Strength (dBuV/m)	Measure Distance (m)
0.009~0.490	2400/F(kHz)	48.5 - 13.8	300
0.490~1.705	24000/F(kHz)	33.8 - 23	30
1.705~30.0	30	29	30
30~88	100	40	3
88~216	150	43.5	3
216~960	200	46	3
Above 960	500	54	3

Note 1:
Qusai-Peak value is measured for frequency below 1GHz except for 9–90 kHz, 110–490 kHz frequency band. Peak and average value are measured for frequency above 1GHz. The limit on average radio frequency emission is as above table. The limit on peak radio frequency emissions is 20 dB above the maximum permitted average emission limit

Note 2:
Measurements may be performed at a distance other than what is specified provided. When performing measurements at a distance other than that specified, the results shall be extrapolated to the specified distance using an extrapolation factor as below, Frequency at or above 30 MHz: 20 dB/decade Frequency below 30 MHz: 40 dB/decade.

3.5.2 Test Procedures

1. Measurement is made at a semi-anechoic chamber that incorporates a turntable allowing a EUT rotation of 360°. A continuously-rotating, remotely-controlled turntable is installed at the test site to support the EUT and facilitate determination of the direction of maximum radiation for each EUT emission frequency. The EUT is placed at test table. For emissions testing at or below 1 GHz, the table height is 80 cm above the reference ground plane. For emission measurements above 1 GHz, the table height is 1.5 m
2. Measurement is made with the antenna positioned in both the horizontal and vertical planes of polarization. The measurement antenna is varied in height (1m ~ 4m) above the reference ground plane to obtain the maximum signal strength. Distance between EUT and antenna is 3 m.
3. This investigation is performed with the EUT rotated 360°, the antenna height scanned between 1 m and 4 m, and the antenna rotated to repeat the measurements for both the horizontal and vertical antenna polarizations.

Note:

1. 120kHz measurement bandwidth of test receiver and Quasi-peak detector is for radiated emission below 1GHz.
2. RBW=1MHz, VBW=3MHz and Peak detector is for peak measured value of radiated emission above 1GHz.
3. RBW=1MHz, VBW=1/T and Peak detector is for average measured value of radiated emission above 1GHz.

3.5.3 Test Setup

Radiated Emissions below 1 GHz

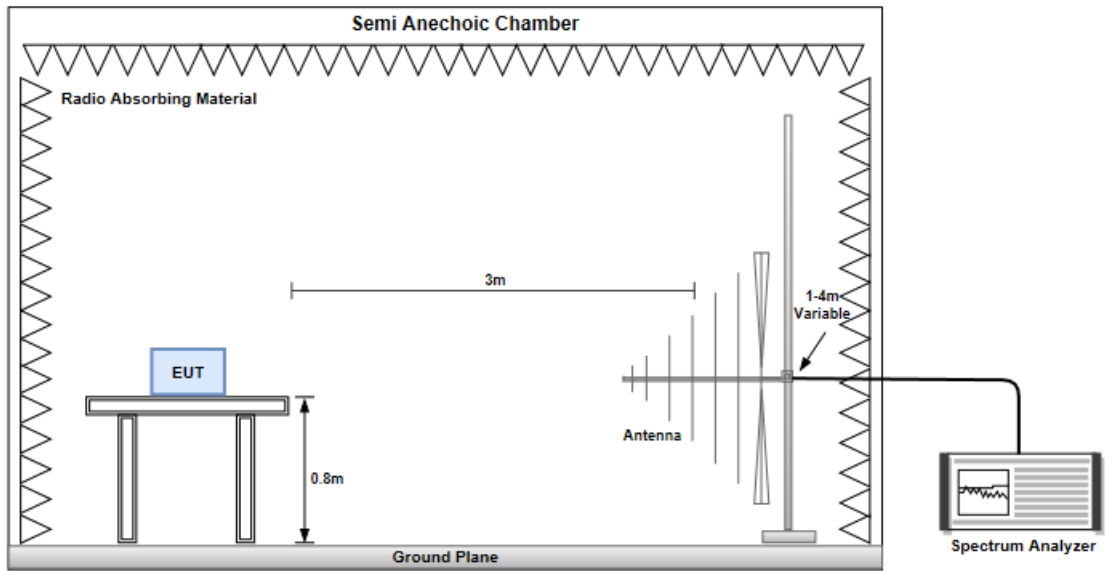

Radiated Emissions above 1 GHz

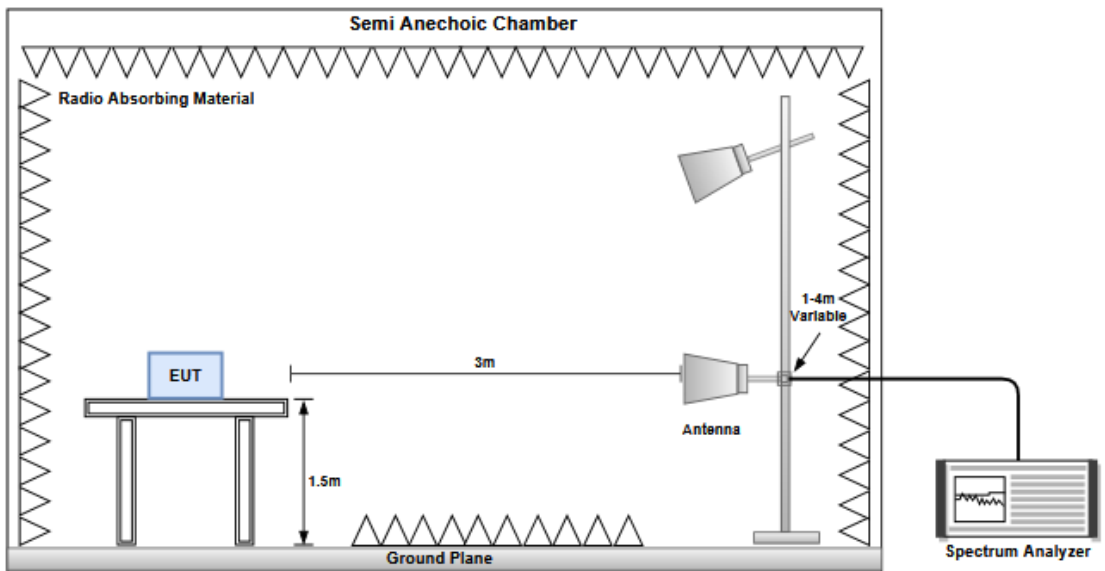

3.5.4 Transmitter Radiated Unwanted Emissions (Below 1GHz)

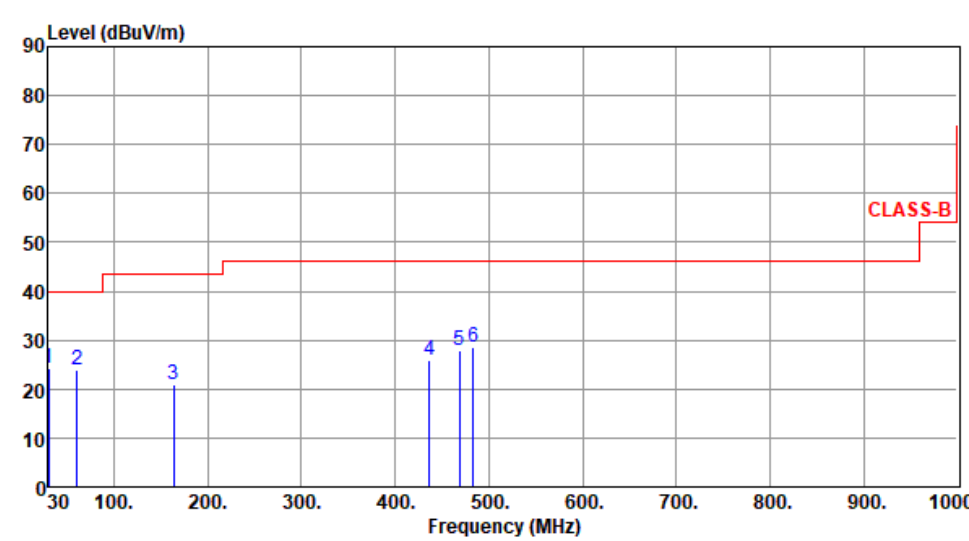
Modulation	11g	Test Freq. (MHz)	2462																																																																																																																																			
Polarization	Horizontal	Test Configuration	1																																																																																																																																			
Test By : Akun Chung Temperature(°C): 24 Humidity(%): 64																																																																																																																																						
																																																																																																																																						
	<table border="1"> <thead> <tr> <th>1</th> <th>2</th> <th>3</th> <th>4</th> <th>5</th> <th>6</th> </tr> </thead> <tbody> <tr> <td>30.00</td> <td>61.04</td> <td>163.86</td> <td>436.43</td> <td>468.44</td> <td>482.99</td> </tr> <tr> <td>24.20</td> <td>23.98</td> <td>21.01</td> <td>25.96</td> <td>27.79</td> <td>28.70</td> </tr> <tr> <td>40.00</td> <td>40.00</td> <td>43.50</td> <td>46.00</td> <td>46.00</td> <td>46.00</td> </tr> <tr> <td>-15.80</td> <td>-16.02</td> <td>-22.49</td> <td>-20.04</td> <td>-18.21</td> <td>-17.30</td> </tr> <tr> <td>33.68</td> <td>33.14</td> <td>30.02</td> <td>30.61</td> <td>31.68</td> <td>32.35</td> </tr> <tr> <td>-9.48</td> <td>-9.16</td> <td>-9.01</td> <td>-4.65</td> <td>-3.89</td> <td>-3.65</td> </tr> <tr> <td>Peak</td> <td>Peak</td> <td>Peak</td> <td>Peak</td> <td>Peak</td> <td>Peak</td> </tr> <tr> <td>---</td> <td>---</td> <td>---</td> <td>---</td> <td>---</td> <td>---</td> </tr> <tr> <td>---</td> <td>---</td> <td>---</td> <td>---</td> <td>---</td> <td>---</td> </tr> </tbody> </table>	1	2	3	4	5	6	30.00	61.04	163.86	436.43	468.44	482.99	24.20	23.98	21.01	25.96	27.79	28.70	40.00	40.00	43.50	46.00	46.00	46.00	-15.80	-16.02	-22.49	-20.04	-18.21	-17.30	33.68	33.14	30.02	30.61	31.68	32.35	-9.48	-9.16	-9.01	-4.65	-3.89	-3.65	Peak	Peak	Peak	Peak	Peak	Peak	---	---	---	---	---	---	---	---	---	---	---	---	<table border="1"> <thead> <tr> <th>Freq.</th> <th>Emission level</th> <th>Limit</th> <th>Margin</th> <th>SA reading</th> <th>Factor</th> <th>Remark</th> <th>ANT High cm</th> <th>Turn Table deg</th> </tr> <tr> <th>MHz</th> <th>dBuV/m</th> <th>dBuV/m</th> <th>dB</th> <th>dBuV</th> <th>dB/m</th> <th></th> <th></th> <th></th> </tr> </thead> <tbody> <tr> <td>30.00</td> <td>24.20</td> <td>40.00</td> <td>-15.80</td> <td>33.68</td> <td>-9.48</td> <td>Peak</td> <td>---</td> <td>---</td> </tr> <tr> <td>61.04</td> <td>23.98</td> <td>40.00</td> <td>-16.02</td> <td>33.14</td> <td>-9.16</td> <td>Peak</td> <td>---</td> <td>---</td> </tr> <tr> <td>163.86</td> <td>21.01</td> <td>43.50</td> <td>-22.49</td> <td>30.02</td> <td>-9.01</td> <td>Peak</td> <td>---</td> <td>---</td> </tr> <tr> <td>436.43</td> <td>25.96</td> <td>46.00</td> <td>-20.04</td> <td>30.61</td> <td>-4.65</td> <td>Peak</td> <td>---</td> <td>---</td> </tr> <tr> <td>468.44</td> <td>27.79</td> <td>46.00</td> <td>-18.21</td> <td>31.68</td> <td>-3.89</td> <td>Peak</td> <td>---</td> <td>---</td> </tr> <tr> <td>482.99</td> <td>28.70</td> <td>46.00</td> <td>-17.30</td> <td>32.35</td> <td>-3.65</td> <td>Peak</td> <td>---</td> <td>---</td> </tr> </tbody> </table>	Freq.	Emission level	Limit	Margin	SA reading	Factor	Remark	ANT High cm	Turn Table deg	MHz	dBuV/m	dBuV/m	dB	dBuV	dB/m				30.00	24.20	40.00	-15.80	33.68	-9.48	Peak	---	---	61.04	23.98	40.00	-16.02	33.14	-9.16	Peak	---	---	163.86	21.01	43.50	-22.49	30.02	-9.01	Peak	---	---	436.43	25.96	46.00	-20.04	30.61	-4.65	Peak	---	---	468.44	27.79	46.00	-18.21	31.68	-3.89	Peak	---	---	482.99	28.70	46.00	-17.30	32.35	-3.65	Peak	---	---
1	2	3	4	5	6																																																																																																																																	
30.00	61.04	163.86	436.43	468.44	482.99																																																																																																																																	
24.20	23.98	21.01	25.96	27.79	28.70																																																																																																																																	
40.00	40.00	43.50	46.00	46.00	46.00																																																																																																																																	
-15.80	-16.02	-22.49	-20.04	-18.21	-17.30																																																																																																																																	
33.68	33.14	30.02	30.61	31.68	32.35																																																																																																																																	
-9.48	-9.16	-9.01	-4.65	-3.89	-3.65																																																																																																																																	
Peak	Peak	Peak	Peak	Peak	Peak																																																																																																																																	
---	---	---	---	---	---																																																																																																																																	
---	---	---	---	---	---																																																																																																																																	
Freq.	Emission level	Limit	Margin	SA reading	Factor	Remark	ANT High cm	Turn Table deg																																																																																																																														
MHz	dBuV/m	dBuV/m	dB	dBuV	dB/m																																																																																																																																	
30.00	24.20	40.00	-15.80	33.68	-9.48	Peak	---	---																																																																																																																														
61.04	23.98	40.00	-16.02	33.14	-9.16	Peak	---	---																																																																																																																														
163.86	21.01	43.50	-22.49	30.02	-9.01	Peak	---	---																																																																																																																														
436.43	25.96	46.00	-20.04	30.61	-4.65	Peak	---	---																																																																																																																														
468.44	27.79	46.00	-18.21	31.68	-3.89	Peak	---	---																																																																																																																														
482.99	28.70	46.00	-17.30	32.35	-3.65	Peak	---	---																																																																																																																														
Note 1: Emission Level (dBuV/m) = SA Reading (dBuV) + Factor* (dB/m) *Factor includes antenna factor , cable loss and amplifier gain Note 2: Margin (dB) = Emission level (dBuV/m) – Limit (dBuV/m). Note 3: All spurious emissions below 30MHz are more than 20 dB below the limit.																																																																																																																																						

Modulation	11g	Test Freq. (MHz)	2462
Polarization	Vertical	Test Configuration	1

Test By :Akun Chung Temperature(°C):24 Humidity(%):64

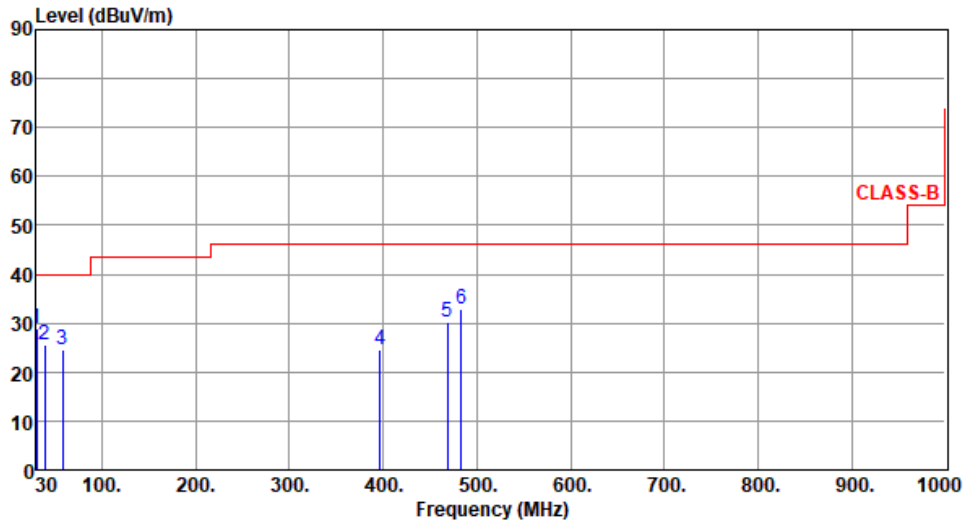

	Freq. MHz	Emission level dBuV/m	Limit dBuV/m	Margin dB	SA reading dBuV	Factor dB/m	Remark	ANT High cm	Turn Table deg
1	30.00	29.03	40.00	-10.97	38.51	-9.48	Peak	---	---
2	38.73	25.47	40.00	-14.53	34.24	-8.77	Peak	---	---
3	58.13	24.61	40.00	-15.39	33.58	-8.97	Peak	---	---
4	396.66	24.64	46.00	-21.36	30.46	-5.82	Peak	---	---
5	468.44	30.34	46.00	-15.66	34.23	-3.89	Peak	---	---
6	482.99	33.01	46.00	-12.99	36.66	-3.65	Peak	---	---

Note 1: Emission Level (dBuV/m) = SA Reading (dBuV) + Factor* (dB/m)

*Factor includes antenna factor , cable loss and amplifier gain

Note 2: Margin (dB) = Emission level (dBuV/m) – Limit (dBuV/m).

Note 3: All spurious emissions below 30MHz are more than 20 dB below the limit.

Modulation	11g	Test Freq. (MHz)	2462
Polarization	Horizontal	Test Configuration	2

Test By :Akun Chung Temperature(°C):24 Humidity(%):64

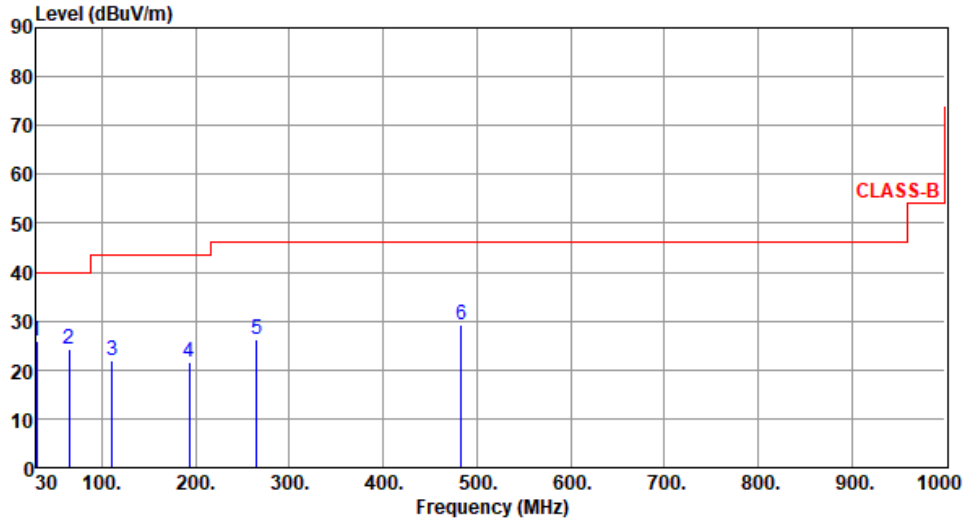

	Freq. MHz	Emission level dBuV/m	Limit dBuV/m	Margin dB	SA reading dBuV	Factor dB/m	Remark	ANT High cm	Turn Table deg
1	30.00	25.85	40.00	-14.15	35.33	-9.48	Peak	---	---
2	64.92	24.32	40.00	-15.68	34.04	-9.72	Peak	---	---
3	110.51	22.01	43.50	-21.49	33.81	-11.80	Peak	---	---
4	192.96	21.48	43.50	-22.02	33.13	-11.65	Peak	---	---
5	264.74	26.34	46.00	-19.66	35.86	-9.52	Peak	---	---
6	482.99	29.37	46.00	-16.63	33.02	-3.65	Peak	---	---

Note 1: Emission Level (dBuV/m) = SA Reading (dBuV) + Factor* (dB/m)

*Factor includes antenna factor , cable loss and amplifier gain

Note 2: Margin (dB) = Emission level (dBuV/m) – Limit (dBuV/m).

Note 3: All spurious emissions below 30MHz are more than 20 dB below the limit.

Modulation	11g	Test Freq. (MHz)	2462
Polarization	Vertical	Test Configuration	2

Test By :Akun Chung Temperature(°C):24 Humidity(%):64

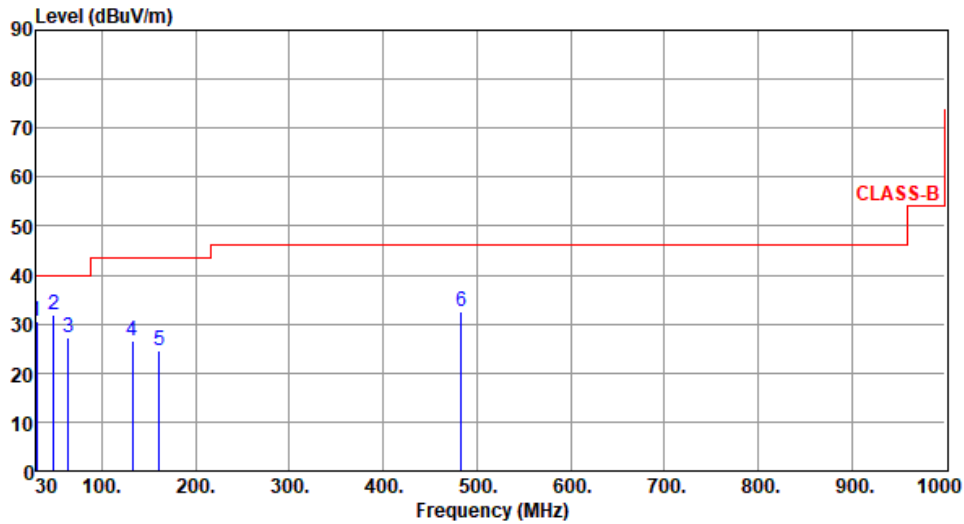

	Freq. MHz	Emission level dBuV/m	Limit dBuV/m	Margin dB	SA reading dBuV	Factor dB/m	Remark	ANT High cm	Turn Table deg
1	30.00	30.55	40.00	-9.45	40.03	-9.48	Peak	---	---
2	48.43	31.95	40.00	-8.05	40.37	-8.42	Peak	---	---
3	63.95	27.12	40.00	-12.88	36.66	-9.54	Peak	---	---
4	132.82	26.55	43.50	-16.95	36.21	-9.66	Peak	---	---
5	160.95	24.45	43.50	-19.05	33.37	-8.92	Peak	---	---
6	482.99	32.57	46.00	-13.43	36.22	-3.65	Peak	---	---

Note 1: Emission Level (dBuV/m) = SA Reading (dBuV) + Factor* (dB/m)

*Factor includes antenna factor , cable loss and amplifier gain

Note 2: Margin (dB) = Emission level (dBuV/m) – Limit (dBuV/m).

Note 3: All spurious emissions below 30MHz are more than 20 dB below the limit.

3.5.5 Transmitter Radiated Unwanted Emissions (Above 1GHz) for 11b

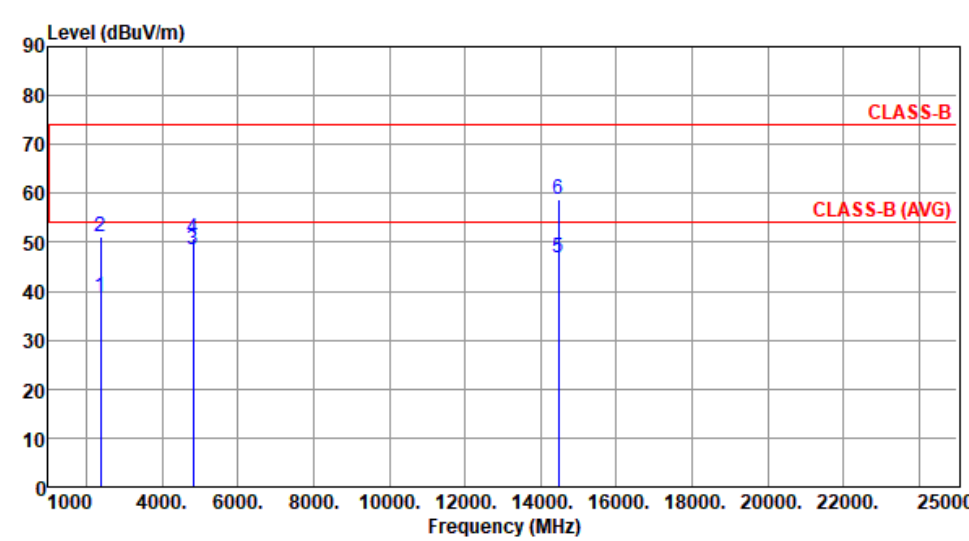
Modulation	11b	Test Freq. (MHz)	2412						
Polarization	Horizontal								
Test By : Roger Lu Temperature(°C):24 Humidity(%):65									
									
	Freq. MHz	Emission level dBuV/m	Limit dBuV/m	Margin dB	SA reading dBuV	Factor dB/m	Remark	ANT High cm	Turn Table deg
1	2390.00	38.85	54.00	-15.15	41.64	-2.79	Average	100	309
2	2390.00	51.16	74.00	-22.84	53.95	-2.79	Peak	100	309
3	4824.00	48.57	54.00	-5.43	45.10	3.47	Average	122	351
4	4824.00	50.78	74.00	-23.22	47.31	3.47	Peak	122	351
5	14472.00	46.83	54.00	-7.17	28.78	18.05	Average	100	87
6	14472.00	58.87	74.00	-15.13	40.82	18.05	Peak	100	87
<p>Note 1: Emission Level (dBuV/m) = SA Reading (dBuV) + Factor* (dB/m) *Factor includes antenna factor , cable loss and amplifier gain Note 2: Margin (dB) = Emission level (dBuV/m) – Limit (dBuV/m).</p>									

Modulation	11b	Test Freq. (MHz)	2412
Polarization	Vertical		

Test By :Roger Lu Temperature(°C):24 Humidity(%):65

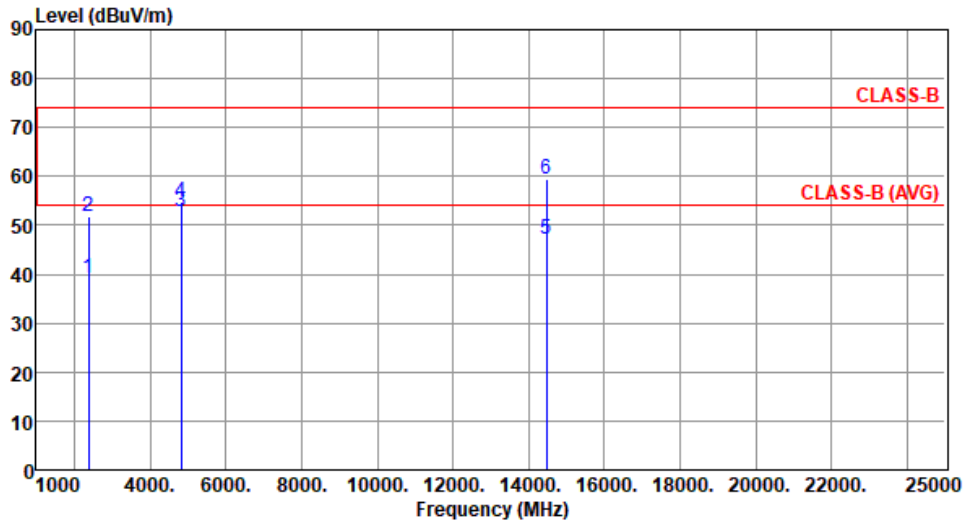

	Freq. MHz	Emission level dBuV/m	Limit dBuV/m	Margin dB	SA reading dBuV	Factor dB/m	Remark	ANT High cm	Turn Table deg
1	2390.00	39.26	54.00	-14.74	42.05	-2.79	Average	111	70
2	2390.00	51.67	74.00	-22.33	54.46	-2.79	Peak	111	70
3	4824.00	52.67	54.00	-1.33	49.20	3.47	Average	100	119
4	4824.00	54.88	74.00	-19.12	51.41	3.47	Peak	100	119
5	14472.00	47.29	54.00	-6.71	29.24	18.05	Average	100	40
6	14472.00	59.36	74.00	-14.64	41.31	18.05	Peak	100	40

Note 1: Emission Level (dBuV/m) = SA Reading (dBuV) + Factor* (dB/m)

*Factor includes antenna factor , cable loss and amplifier gain

Note 2: Margin (dB) = Emission level (dBuV/m) – Limit (dBuV/m).

Modulation	11b	Test Freq. (MHz)	2437
Polarization	Horizontal		

Test By :Roger Lu Temperature(°C):24 Humidity(%):65

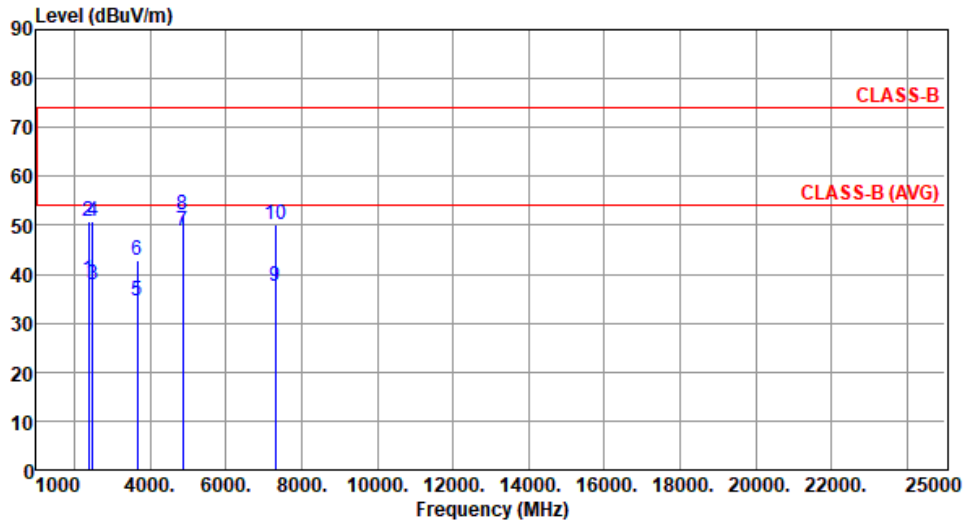

	Freq. MHz	Emission level dBuV/m	Limit dBuV/m	Margin dB	SA reading dBuV	Factor dB/m	Remark	ANT High cm	Turn Table deg
1	2390.00	38.77	54.00	-15.23	41.56	-2.79	Average	100	306
2	2390.00	50.82	74.00	-23.18	53.61	-2.79	Peak	100	306
3	2483.50	38.00	54.00	-16.00	40.74	-2.74	Average	100	306
4	2483.50	50.71	74.00	-23.29	53.45	-2.74	Peak	100	306
5	3655.50	34.66	54.00	-19.34	34.34	0.32	Average	130	192
6	3655.50	42.82	74.00	-31.18	42.50	0.32	Peak	130	192
7	4874.00	48.68	54.00	-5.32	45.23	3.45	Average	122	357
8	4874.00	52.00	74.00	-22.00	48.55	3.45	Peak	122	357
9	7311.00	37.54	54.00	-16.46	28.55	8.99	Average	100	50
10	7311.00	50.16	74.00	-23.84	41.17	8.99	Peak	100	50

Note 1: Emission Level (dBuV/m) = SA Reading (dBuV) + Factor* (dB/m)

*Factor includes antenna factor , cable loss and amplifier gain

Note 2: Margin (dB) = Emission level (dBuV/m) – Limit (dBuV/m).

Modulation	11b	Test Freq. (MHz)	2437
Polarization	Vertical		

Test By :Roger Lu Temperature(°C):24 Humidity(%):65

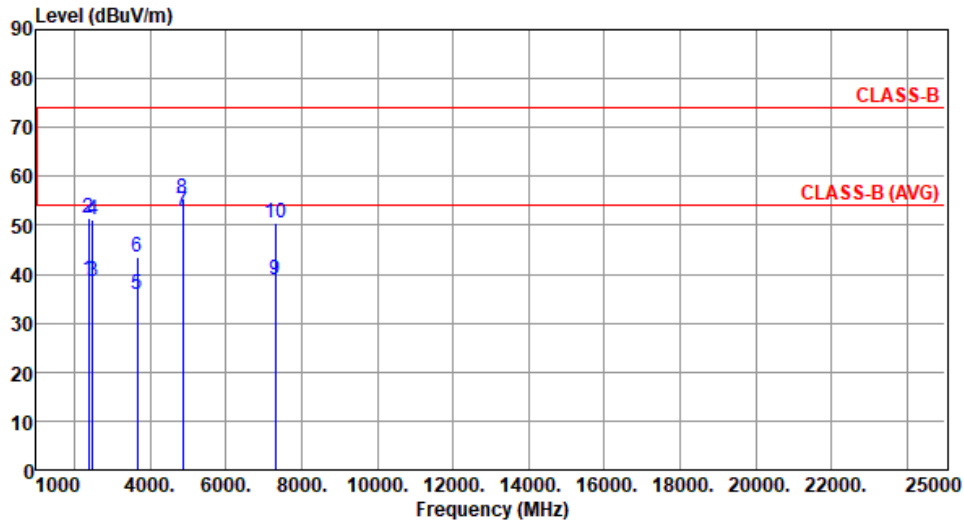

	Freq. MHz	Emission level dBuV/m	Limit dBuV/m	Margin dB	SA reading dBuV	Factor dB/m	Remark	ANT High cm	Turn Table deg
1	2390.00	38.83	54.00	-15.17	41.62	-2.79	Average	103	76
2	2390.00	51.36	74.00	-22.64	54.15	-2.79	Peak	103	76
3	2483.50	38.52	54.00	-15.48	41.26	-2.74	Average	103	76
4	2483.50	51.15	74.00	-22.85	53.89	-2.74	Peak	103	76
5	3655.50	35.95	54.00	-18.05	35.63	0.32	Average	122	307
6	3655.50	43.42	74.00	-30.58	43.10	0.32	Peak	122	307
7	4874.00	52.71	54.00	-1.29	49.26	3.45	Average	100	120
8	4874.00	55.31	74.00	-18.69	51.86	3.45	Peak	100	120
9	7311.00	38.71	54.00	-15.29	29.72	8.99	Average	148	181
10	7311.00	50.60	74.00	-23.40	41.61	8.99	Peak	148	181

Note 1: Emission Level (dBuV/m) = SA Reading (dBuV) + Factor* (dB/m)

*Factor includes antenna factor , cable loss and amplifier gain

Note 2: Margin (dB) = Emission level (dBuV/m) – Limit (dBuV/m).

Modulation	11b	Test Freq. (MHz)	2462
Polarization	Horizontal		

Test By :Roger Lu Temperature(°C):24 Humidity(%):65

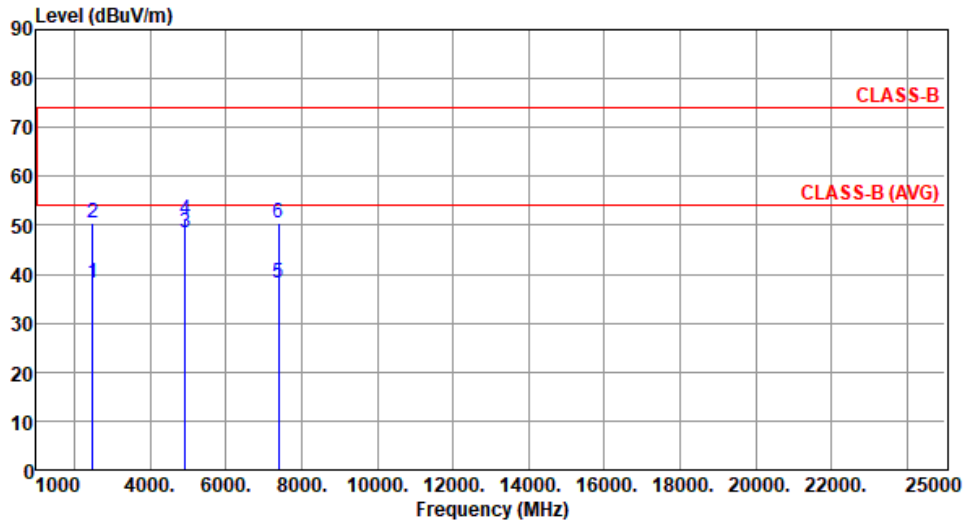

	Freq. MHz	Emission level dBuV/m	Limit dBuV/m	Margin dB	SA reading dBuV	Factor dB/m	Remark	ANT High cm	Turn Table deg
1	2483.50	38.16	54.00	-15.84	40.90	-2.74	Average	100	317
2	2483.50	50.34	74.00	-23.66	53.08	-2.74	Peak	100	317
3	4924.00	48.57	54.00	-5.43	45.02	3.55	Average	100	303
4	4924.00	51.11	74.00	-22.89	47.56	3.55	Peak	100	303
5	7386.00	38.16	54.00	-15.84	29.19	8.97	Average	100	209
6	7386.00	50.35	74.00	-23.65	41.38	8.97	Peak	100	209

Note 1: Emission Level (dBuV/m) = SA Reading (dBuV) + Factor* (dB/m)
 *Factor includes antenna factor , cable loss and amplifier gain
 Note 2: Margin (dB) = Emission level (dBuV/m) – Limit (dBuV/m).

Modulation	11b	Test Freq. (MHz)	2462
Polarization	Vertical		

Test By :Roger Lu Temperature(°C):24 Humidity(%) :65

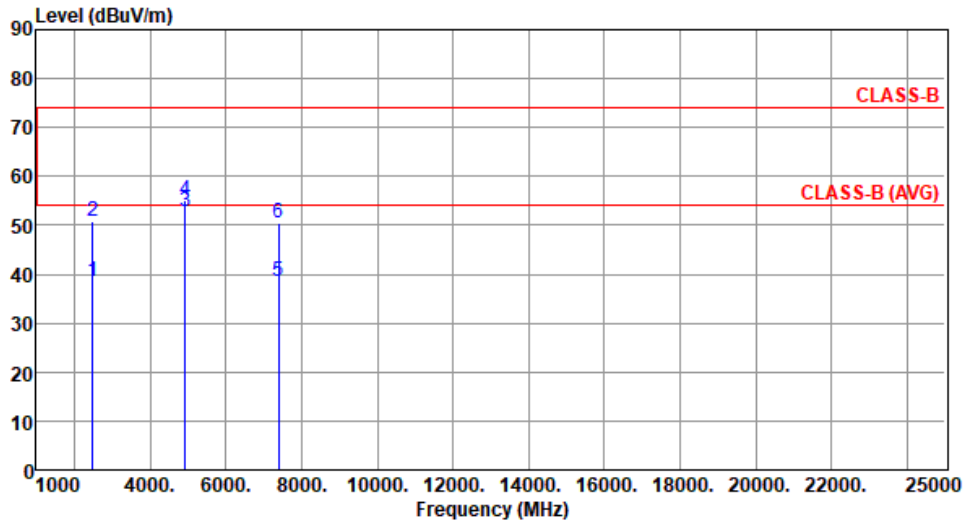

	Freq. MHz	Emission level dBuV/m	Limit dBuV/m	Margin dB	SA reading dBuV	Factor dB/m	Remark	ANT High cm	Turn Table deg
1	2483.50	38.52	54.00	-15.48	41.26	-2.74	Average	100	74
2	2483.50	50.83	74.00	-23.17	53.57	-2.74	Peak	100	74
3	4924.00	52.79	54.00	-1.21	49.24	3.55	Average	100	132
4	4924.00	55.28	74.00	-18.72	51.73	3.55	Peak	100	132
5	7386.00	38.48	54.00	-15.52	29.51	8.97	Average	140	186
6	7386.00	50.53	74.00	-23.47	41.56	8.97	Peak	140	186

Note 1: Emission Level (dBuV/m) = SA Reading (dBuV) + Factor* (dB/m)

*Factor includes antenna factor , cable loss and amplifier gain

Note 2: Margin (dB) = Emission level (dBuV/m) – Limit (dBuV/m).

3.5.6 Transmitter Radiated Unwanted Emissions (Above 1GHz) for 11g

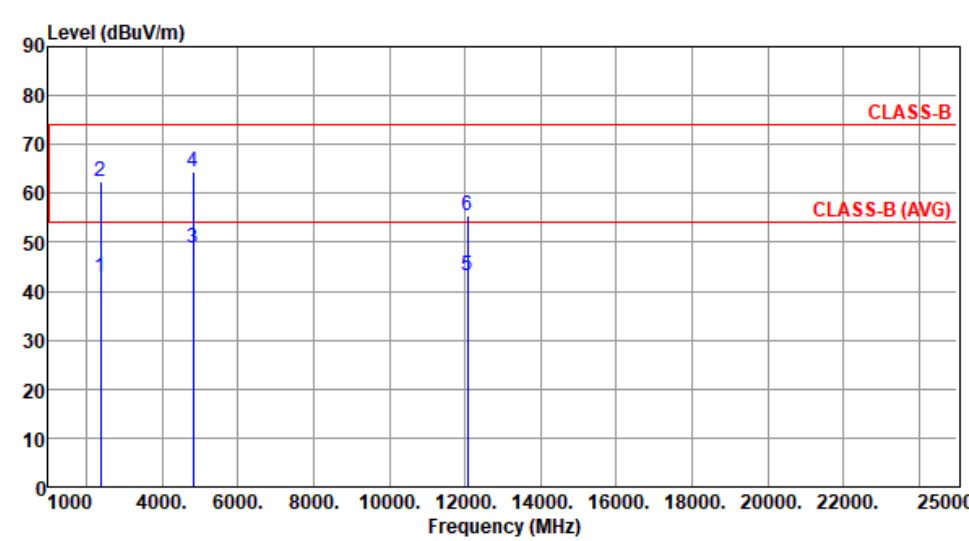
Modulation	11g	Test Freq. (MHz)	2412						
Polarization	Horizontal								
Test By : Roger Lu Temperature(°C):24 Humidity(%):65									
									
	Freq.	Emission level	Limit	Margin	SA reading	Factor	Remark	ANT High	Turn Table
	MHz	dBuV/m	dBuV/m	dB	dBuV	dB/m		cm	deg
1	2390.00	42.85	54.00	-11.15	45.64	-2.79	Average	100	300
2	2390.00	62.51	74.00	-11.49	65.30	-2.79	Peak	100	300
3	4824.00	48.69	54.00	-5.31	45.22	3.47	Average	122	6
4	4824.00	64.36	74.00	-9.64	60.89	3.47	Peak	122	6
5	12060.00	43.17	54.00	-10.83	28.85	14.32	Average	100	85
6	12060.00	55.49	74.00	-18.51	41.17	14.32	Peak	100	85
<p>Note 1: Emission Level (dBuV/m) = SA Reading (dBuV) + Factor* (dB/m) *Factor includes antenna factor , cable loss and amplifier gain Note 2: Margin (dB) = Emission level (dBuV/m) – Limit (dBuV/m).</p>									

Modulation	11g	Test Freq. (MHz)	2412
Polarization	Vertical		

Test By :Roger Lu Temperature(°C):24 Humidity(%):65

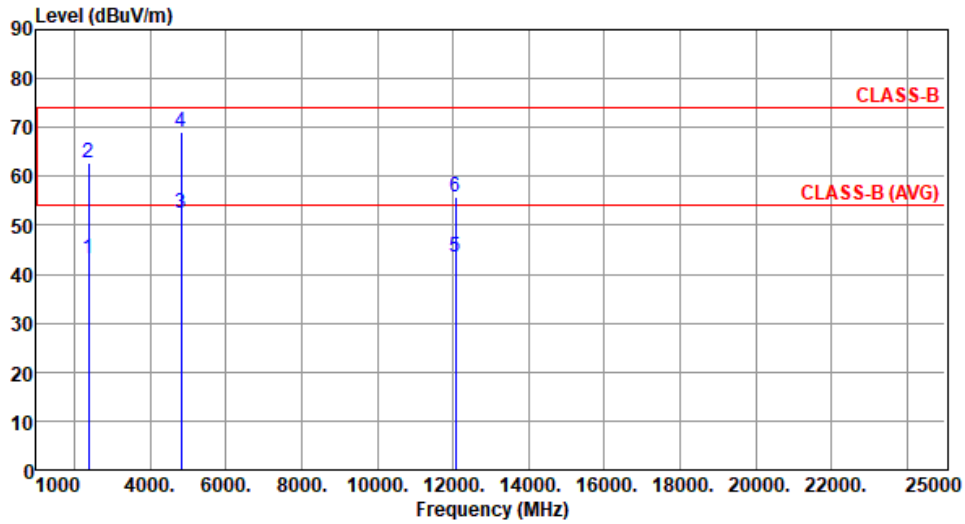

	Freq. MHz	Emission level dBuV/m	Limit dBuV/m	Margin dB	SA reading dBuV	Factor dB/m	Remark	ANT High cm	Turn Table deg
1	2390.00	43.06	54.00	-10.94	45.85	-2.79	Average	100	72
2	2390.00	62.84	74.00	-11.16	65.63	-2.79	Peak	100	72
3	4824.00	52.55	54.00	-1.45	49.08	3.47	Average	100	131
4	4824.00	69.00	74.00	-5.00	65.53	3.47	Peak	100	131
5	12060.00	43.57	54.00	-10.43	29.25	14.32	Average	100	40
6	12060.00	55.90	74.00	-18.10	41.58	14.32	Peak	100	40

Note 1: Emission Level (dBuV/m) = SA Reading (dBuV) + Factor* (dB/m)
 *Factor includes antenna factor , cable loss and amplifier gain
 Note 2: Margin (dB) = Emission level (dBuV/m) – Limit (dBuV/m).

Modulation	11g	Test Freq. (MHz)	2437
Polarization	Horizontal		

Test By :Roger Lu Temperature(°C):24 Humidity(%):65

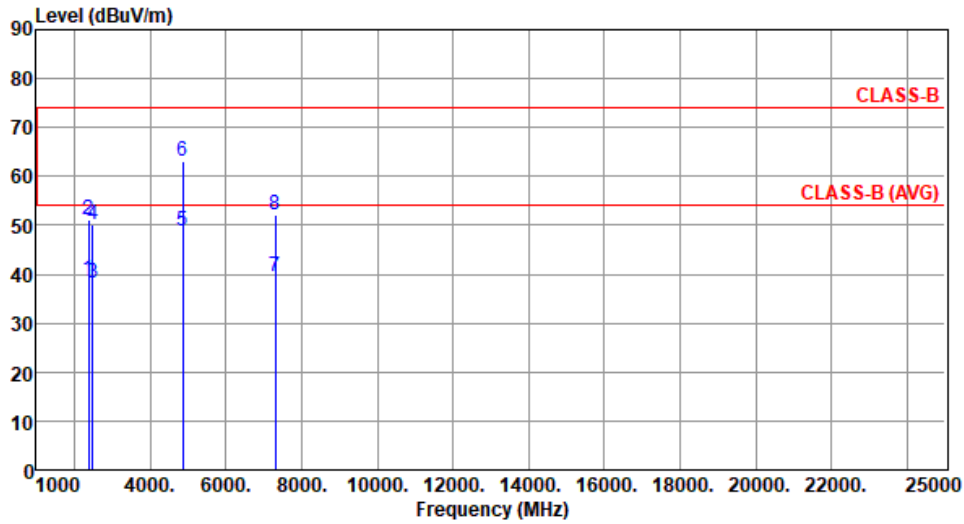

	Freq. MHz	Emission level dBuV/m	Limit dBuV/m	Margin dB	SA reading dBuV	Factor dB/m	Remark	ANT High cm	Turn Table deg
1	2390.00	38.77	54.00	-15.23	41.56	-2.79	Average	100	304
2	2390.00	50.99	74.00	-23.01	53.78	-2.79	Peak	100	304
3	2483.50	38.27	54.00	-15.73	41.01	-2.74	Average	100	304
4	2483.50	50.31	74.00	-23.69	53.05	-2.74	Peak	100	304
5	4874.00	48.69	54.00	-5.31	45.24	3.45	Average	120	3
6	4874.00	63.16	74.00	-10.84	59.71	3.45	Peak	120	3
7	7311.00	39.39	54.00	-14.61	30.40	8.99	Average	100	222
8	7311.00	52.26	74.00	-21.74	43.27	8.99	Peak	100	222

Note 1: Emission Level (dBuV/m) = SA Reading (dBuV) + Factor* (dB/m)

*Factor includes antenna factor , cable loss and amplifier gain

Note 2: Margin (dB) = Emission level (dBuV/m) – Limit (dBuV/m).

Modulation	11g	Test Freq. (MHz)	2437
Polarization	Vertical		

Test By :Roger Lu Temperature(°C):24 Humidity(%):65

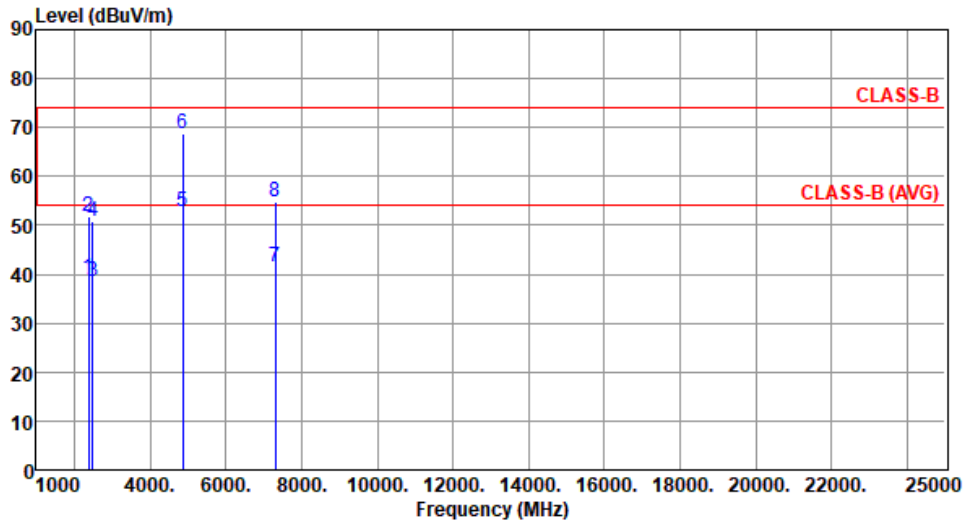

	Freq. MHz	Emission level dBuV/m	Limit dBuV/m	Margin dB	SA reading dBuV	Factor dB/m	Remark	ANT High cm	Turn Table deg
1	2390.00	39.10	54.00	-14.90	41.89	-2.79	Average	100	73
2	2390.00	51.67	74.00	-22.33	54.46	-2.79	Peak	100	73
3	2483.50	38.41	54.00	-15.59	41.15	-2.74	Average	100	73
4	2483.50	50.75	74.00	-23.25	53.49	-2.74	Peak	100	73
5	4874.00	52.78	54.00	-1.22	49.33	3.45	Average	100	144
6	4874.00	68.79	74.00	-5.21	65.34	3.45	Peak	100	144
7	7311.00	41.56	54.00	-12.44	32.57	8.99	Average	100	204
8	7311.00	54.77	74.00	-19.23	45.78	8.99	Peak	100	204

Note 1: Emission Level (dBuV/m) = SA Reading (dBuV) + Factor* (dB/m)

*Factor includes antenna factor , cable loss and amplifier gain

Note 2: Margin (dB) = Emission level (dBuV/m) – Limit (dBuV/m).

Modulation	11g	Test Freq. (MHz)	2462
Polarization	Horizontal		

Test By :Roger Lu Temperature(°C):24 Humidity(%):65

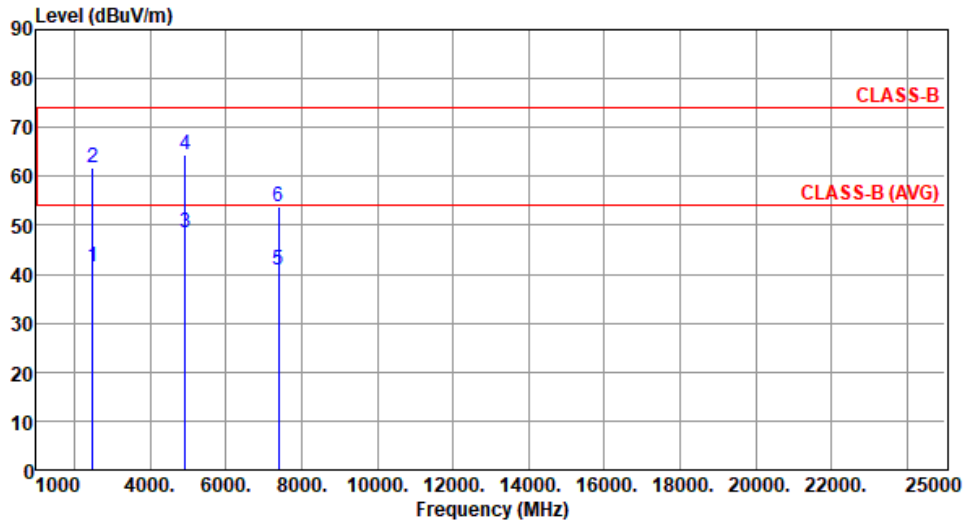

	Freq. MHz	Emission level dBUV/m	Limit dBUV/m	Margin dB	SA reading dBUV	Factor dB/m	Remark	ANT High cm	Turn Table deg
1	2483.50	41.55	54.00	-12.45	44.29	-2.74	Average	100	311
2	2483.50	61.74	74.00	-12.26	64.48	-2.74	Peak	100	311
3	4924.00	48.65	54.00	-5.35	45.10	3.55	Average	123	11
4	4924.00	64.28	74.00	-9.72	60.73	3.55	Peak	123	11
5	7386.00	40.92	54.00	-13.08	31.95	8.97	Average	100	221
6	7386.00	53.94	74.00	-20.06	44.97	8.97	Peak	100	221

Note 1: Emission Level (dBUV/m) = SA Reading (dBUV) + Factor* (dB/m)
 *Factor includes antenna factor , cable loss and amplifier gain
 Note 2: Margin (dB) = Emission level (dBUV/m) – Limit (dBUV/m).

Modulation	11g	Test Freq. (MHz)	2462
Polarization	Vertical		

Test By :Roger Lu Temperature(°C):24 Humidity(%):65

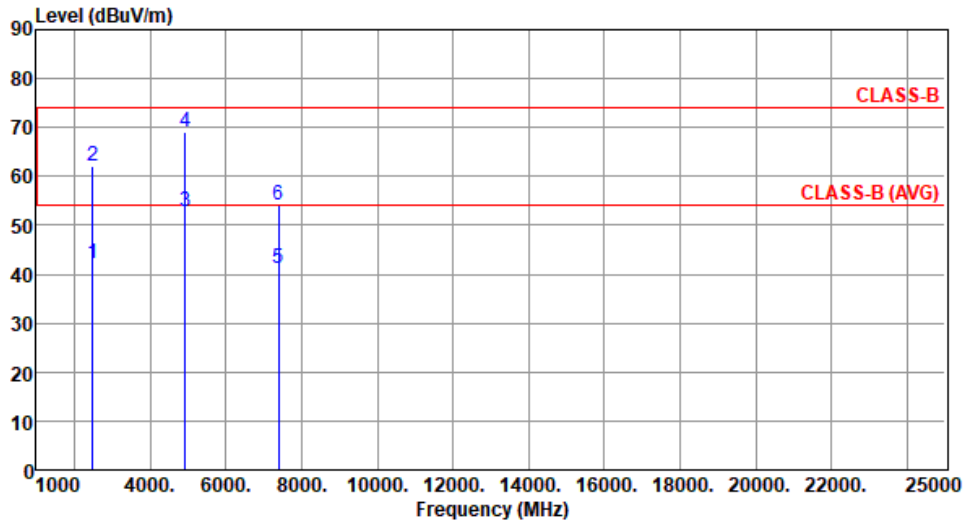

	Freq. MHz	Emission level dBUV/m	Limit dBUV/m	Margin dB	SA reading dBUV	Factor dB/m	Remark	ANT High cm	Turn Table deg
1	2483.50	42.05	54.00	-11.95	44.79	-2.74	Average	100	71
2	2483.50	62.25	74.00	-11.75	64.99	-2.74	Peak	100	71
3	4924.00	52.95	54.00	-1.05	49.40	3.55	Average	100	134
4	4924.00	69.03	74.00	-4.97	65.48	3.55	Peak	100	134
5	7386.00	41.13	54.00	-12.87	32.16	8.97	Average	100	205
6	7386.00	54.27	74.00	-19.73	45.30	8.97	Peak	100	205

Note 1: Emission Level (dBUV/m) = SA Reading (dBUV) + Factor* (dB/m)

*Factor includes antenna factor , cable loss and amplifier gain

Note 2: Margin (dB) = Emission level (dBUV/m) – Limit (dBUV/m).

3.5.7 Transmitter Radiated Unwanted Emissions (Above 1GHz) for HT20

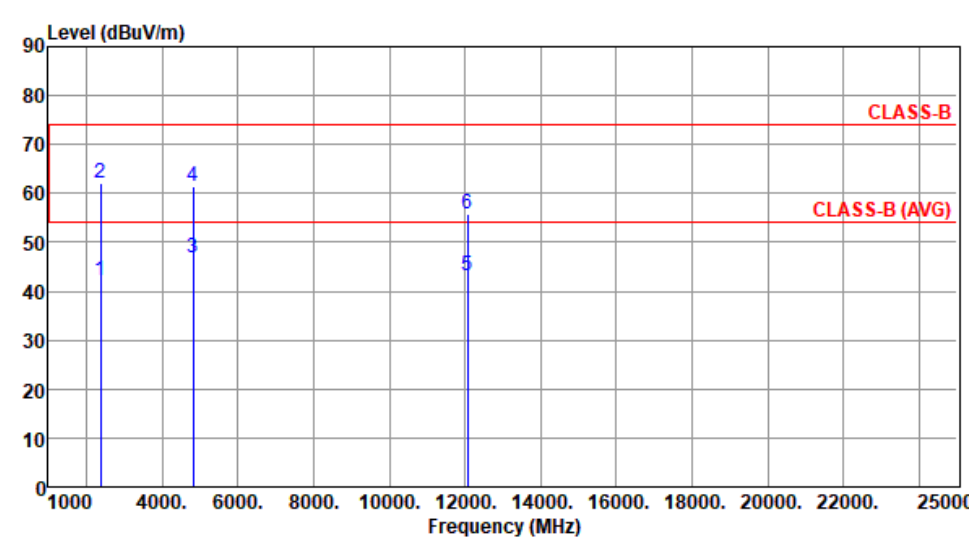
Modulation	HT20	Test Freq. (MHz)	2412						
Polarization	Horizontal								
Test By : Roger Lu Temperature(°C):24 Humidity(%):65									
									
	Freq.	Emission level	Limit	Margin	SA reading	Factor	Remark	ANT High	Turn Table
	MHz	dBuV/m	dBuV/m	dB	dBuV	dB/m		cm	deg
1	2390.00	42.17	54.00	-11.83	44.96	-2.79	Average	103	323
2	2390.00	62.22	74.00	-11.78	65.01	-2.79	Peak	103	323
3	4824.00	46.88	54.00	-7.12	43.41	3.47	Average	126	19
4	4824.00	61.58	74.00	-12.42	58.11	3.47	Peak	126	19
5	12060.00	43.17	54.00	-10.83	28.85	14.32	Average	100	208
6	12060.00	55.73	74.00	-18.27	41.41	14.32	Peak	100	208

Note 1: Emission Level (dBuV/m) = SA Reading (dBuV) + Factor* (dB/m)
 *Factor includes antenna factor , cable loss and amplifier gain
 Note 2: Margin (dB) = Emission level (dBuV/m) – Limit (dBuV/m).

Modulation	HT20	Test Freq. (MHz)	2412
Polarization	Vertical		

Test By :Roger Lu Temperature(°C):24 Humidity(%):65

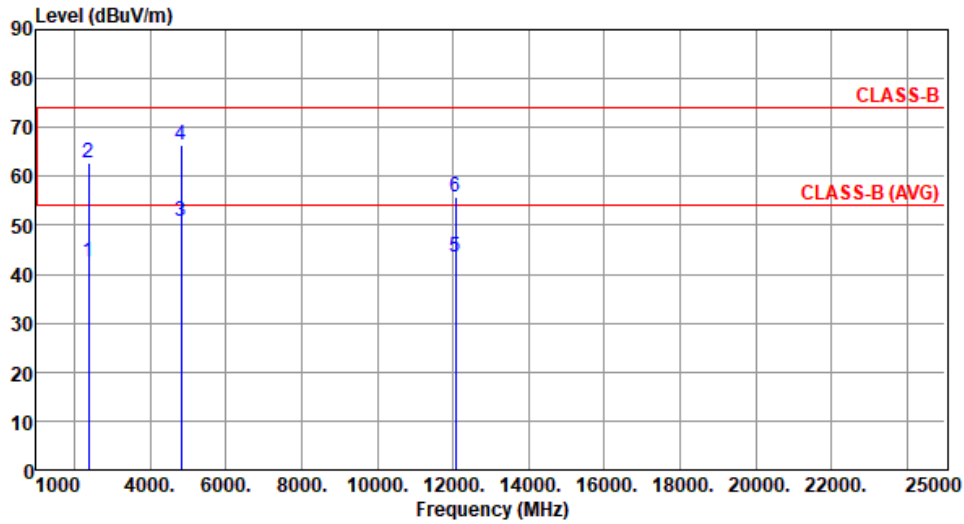

	Freq. MHz	Emission level dBuV/m	Limit dBuV/m	Margin dB	SA reading dBuV	Factor dB/m	Remark	ANT High cm	Turn Table deg
1	2390.00	42.60	54.00	-11.40	45.39	-2.79	Average	129	73
2	2390.00	62.89	74.00	-11.11	65.68	-2.79	Peak	129	73
3	4824.00	50.70	54.00	-3.30	47.23	3.47	Average	111	115
4	4824.00	66.36	74.00	-7.64	62.89	3.47	Peak	111	115
5	12060.00	43.57	54.00	-10.43	29.25	14.32	Average	100	50
6	12060.00	55.94	74.00	-18.06	41.62	14.32	Peak	100	50

Note 1: Emission Level (dBuV/m) = SA Reading (dBuV) + Factor* (dB/m)

*Factor includes antenna factor , cable loss and amplifier gain

Note 2: Margin (dB) = Emission level (dBuV/m) – Limit (dBuV/m).

Modulation	HT20	Test Freq. (MHz)	2437
Polarization	Horizontal		

Test By :Roger Lu Temperature(°C):24 Humidity(%):65

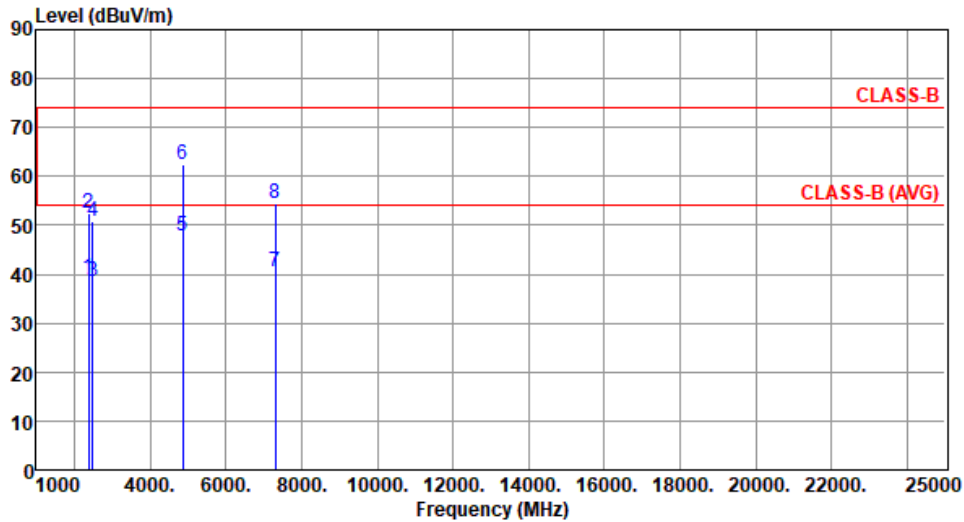

	Freq. MHz	Emission level dBuV/m	Limit dBuV/m	Margin dB	SA reading dBuV	Factor dB/m	Remark	ANT High cm	Turn Table deg
1	2390.00	39.17	54.00	-14.83	41.96	-2.79	Average	100	298
2	2390.00	52.43	74.00	-21.57	55.22	-2.79	Peak	100	298
3	2483.50	38.63	54.00	-15.37	41.37	-2.74	Average	100	298
4	2483.50	50.67	74.00	-23.33	53.41	-2.74	Peak	100	298
5	4874.00	47.73	54.00	-6.27	44.28	3.45	Average	126	18
6	4874.00	62.43	74.00	-11.57	58.98	3.45	Peak	126	18
7	7311.00	40.52	54.00	-13.48	31.53	8.99	Average	102	211
8	7311.00	54.47	74.00	-19.53	45.48	8.99	Peak	102	211

Note 1: Emission Level (dBuV/m) = SA Reading (dBuV) + Factor* (dB/m)

*Factor includes antenna factor , cable loss and amplifier gain

Note 2: Margin (dB) = Emission level (dBuV/m) – Limit (dBuV/m).

Modulation	HT20	Test Freq. (MHz)	2437
Polarization	Vertical		

Test By :Roger Lu Temperature(°C):24 Humidity(%):65

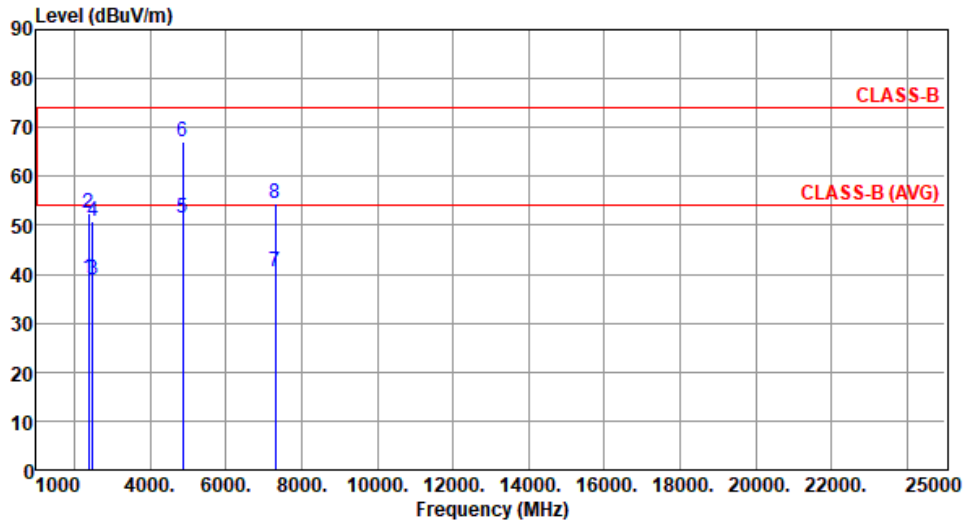

	Freq. MHz	Emission level dBuV/m	Limit dBuV/m	Margin dB	SA reading dBuV	Factor dB/m	Remark	ANT High cm	Turn Table deg
1	2390.00	39.26	54.00	-14.74	42.05	-2.79	Average	100	84
2	2390.00	52.61	74.00	-21.39	55.40	-2.79	Peak	100	84
3	2483.50	38.71	54.00	-15.29	41.45	-2.74	Average	100	84
4	2483.50	50.85	74.00	-23.15	53.59	-2.74	Peak	100	84
5	4874.00	51.51	54.00	-2.49	48.06	3.45	Average	100	135
6	4874.00	67.05	74.00	-6.95	63.60	3.45	Peak	100	135
7	7311.00	40.68	54.00	-13.32	31.69	8.99	Average	100	205
8	7311.00	54.61	74.00	-19.39	45.62	8.99	Peak	100	205

Note 1: Emission Level (dBuV/m) = SA Reading (dBuV) + Factor* (dB/m)

*Factor includes antenna factor , cable loss and amplifier gain

Note 2: Margin (dB) = Emission level (dBuV/m) – Limit (dBuV/m).

Modulation	HT20	Test Freq. (MHz)	2462
Polarization	Horizontal		

Test By :Roger Lu Temperature(°C):24 Humidity(%):65

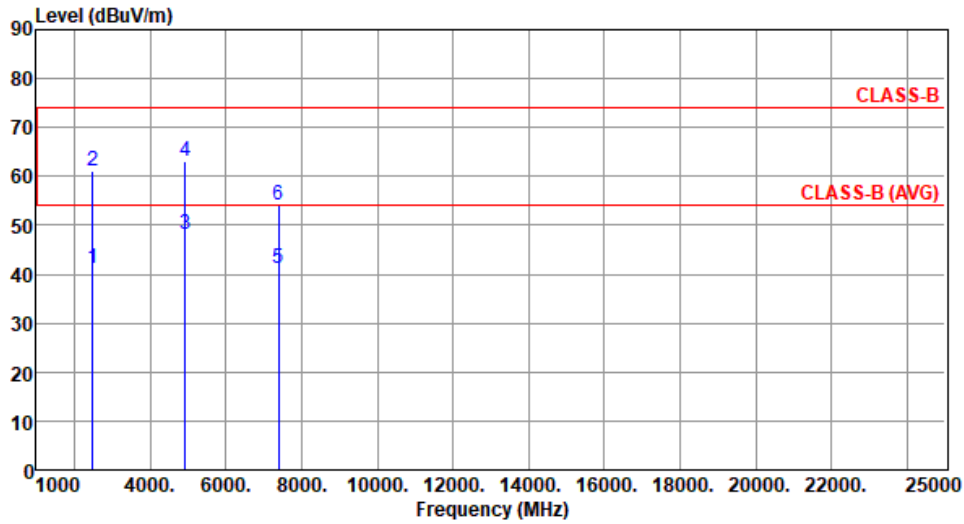

	Freq. MHz	Emission level dBuV/m	Limit dBuV/m	Margin dB	SA reading dBuV	Factor dB/m	Remark	ANT High cm	Turn Table deg
1	2483.50	41.08	54.00	-12.92	43.82	-2.74	Average	100	289
2	2483.50	61.24	74.00	-12.76	63.98	-2.74	Peak	100	289
3	4924.00	48.16	54.00	-5.84	44.61	3.55	Average	124	28
4	4924.00	63.17	74.00	-10.83	59.62	3.55	Peak	124	28
5	7386.00	41.08	54.00	-12.92	32.11	8.97	Average	100	217
6	7386.00	54.06	74.00	-19.94	45.09	8.97	Peak	100	217

Note 1: Emission Level (dBuV/m) = SA Reading (dBuV) + Factor* (dB/m)

*Factor includes antenna factor , cable loss and amplifier gain

Note 2: Margin (dB) = Emission level (dBuV/m) – Limit (dBuV/m).

Modulation	HT20	Test Freq. (MHz)	2462
Polarization	Vertical		

Test By :Roger Lu Temperature(°C):24 Humidity(%):65

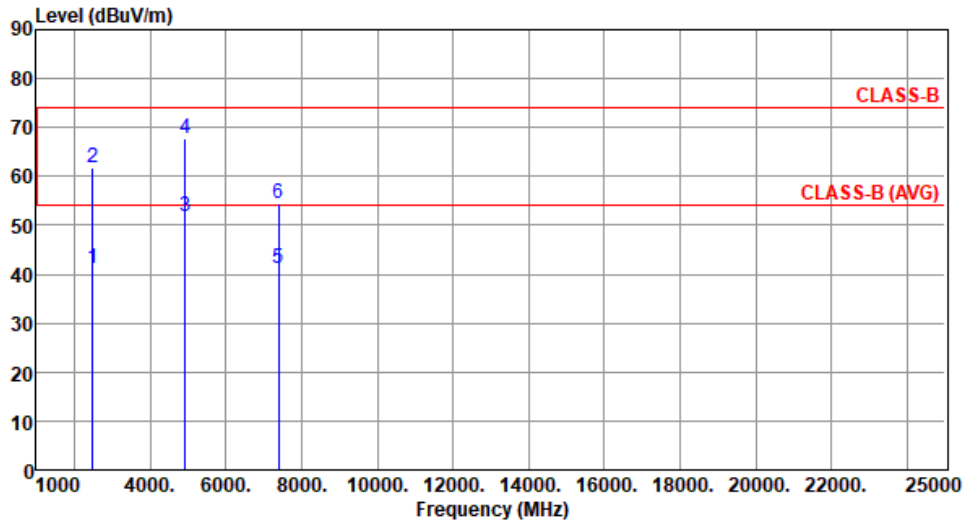

	Freq. MHz	Emission level dBuV/m	Limit dBuV/m	Margin dB	SA reading dBuV	Factor dB/m	Remark	ANT High cm	Turn Table deg
1	2483.50	41.32	54.00	-12.68	44.06	-2.74	Average	100	76
2	2483.50	61.89	74.00	-12.11	64.63	-2.74	Peak	100	76
3	4924.00	51.97	54.00	-2.03	48.42	3.55	Average	100	131
4	4924.00	67.85	74.00	-6.15	64.30	3.55	Peak	100	131
5	7386.00	41.23	54.00	-12.77	32.26	8.97	Average	100	206
6	7386.00	54.46	74.00	-19.54	45.49	8.97	Peak	100	206

Note 1: Emission Level (dBuV/m) = SA Reading (dBuV) + Factor* (dB/m)

*Factor includes antenna factor , cable loss and amplifier gain

Note 2: Margin (dB) = Emission level (dBuV/m) – Limit (dBuV/m).

3.6 Emissions in Non-Restricted Frequency Bands

3.6.1 Emissions in Non-Restricted Frequency Bands Limit

Peak power in any 100 kHz bandwidth outside of the authorized frequency band shall be attenuated by at least 20 dB relative to the maximum in-band peak PSD level in 100 kHz.

3.6.2 Test Procedures

Reference level measurement

1. Set RBW=100kHz, VBW = 300kHz , Detector = Peak, Sweep time = Auto
2. Trace = max hold , Allow Trace to fully stabilize
3. Use the peak marker function to determine the maximum PSD level

Emission level measurement

1. Set RBW=100kHz, VBW = 300kHz , Detector = Peak, Sweep time = Auto
2. Trace = max hold , Allow Trace to fully stabilize
3. Scan Frequency range is up to 25GHz
4. Use the peak marker function to determine the maximum amplitude level

3.6.3 Test Setup

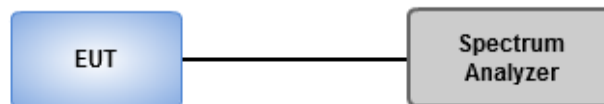

3.6.4 Unwanted Emissions into Non-Restricted Frequency Bands

Ambient Condition	23°C / 63%	Tested By	BRAD WU
-------------------	------------	-----------	---------

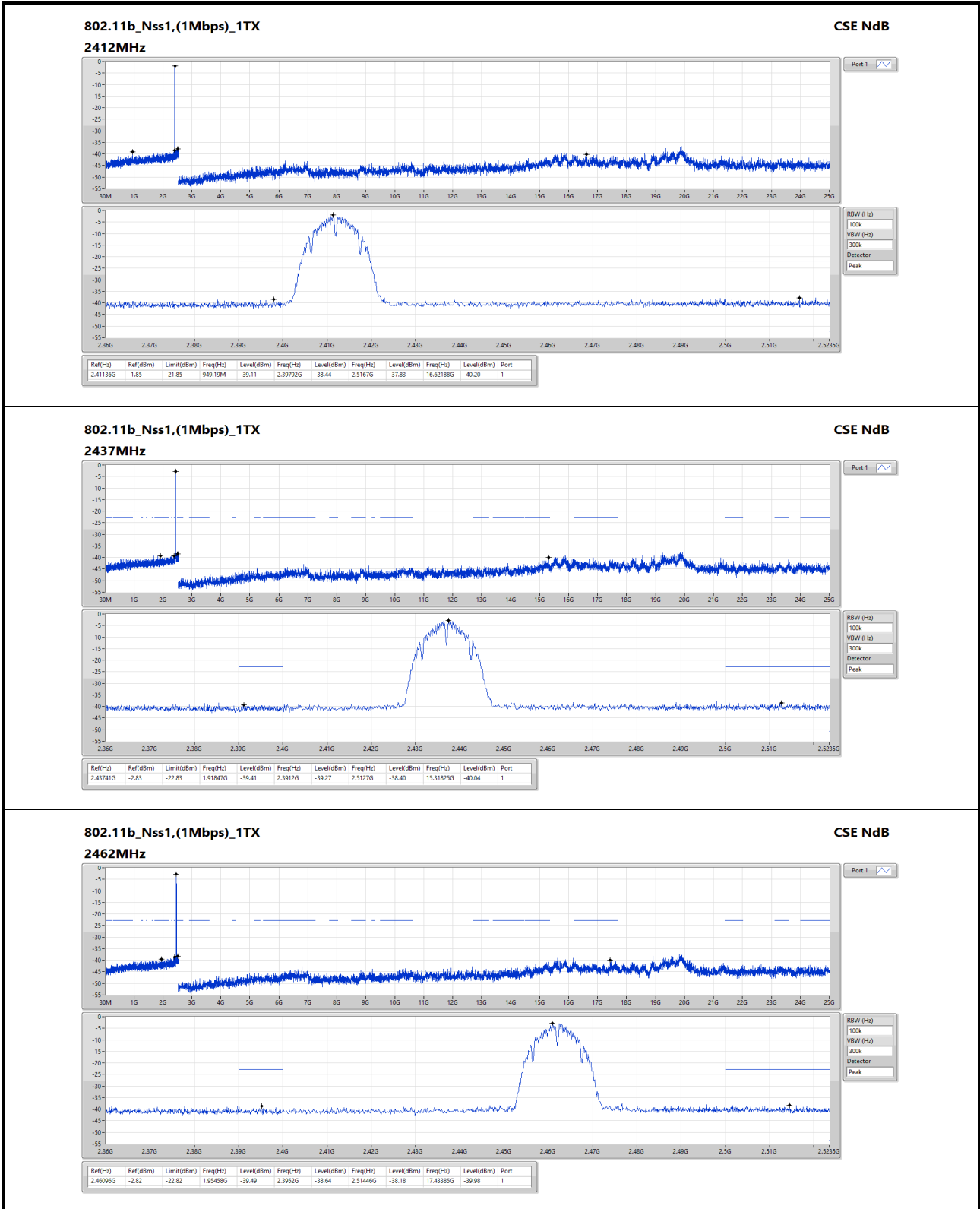

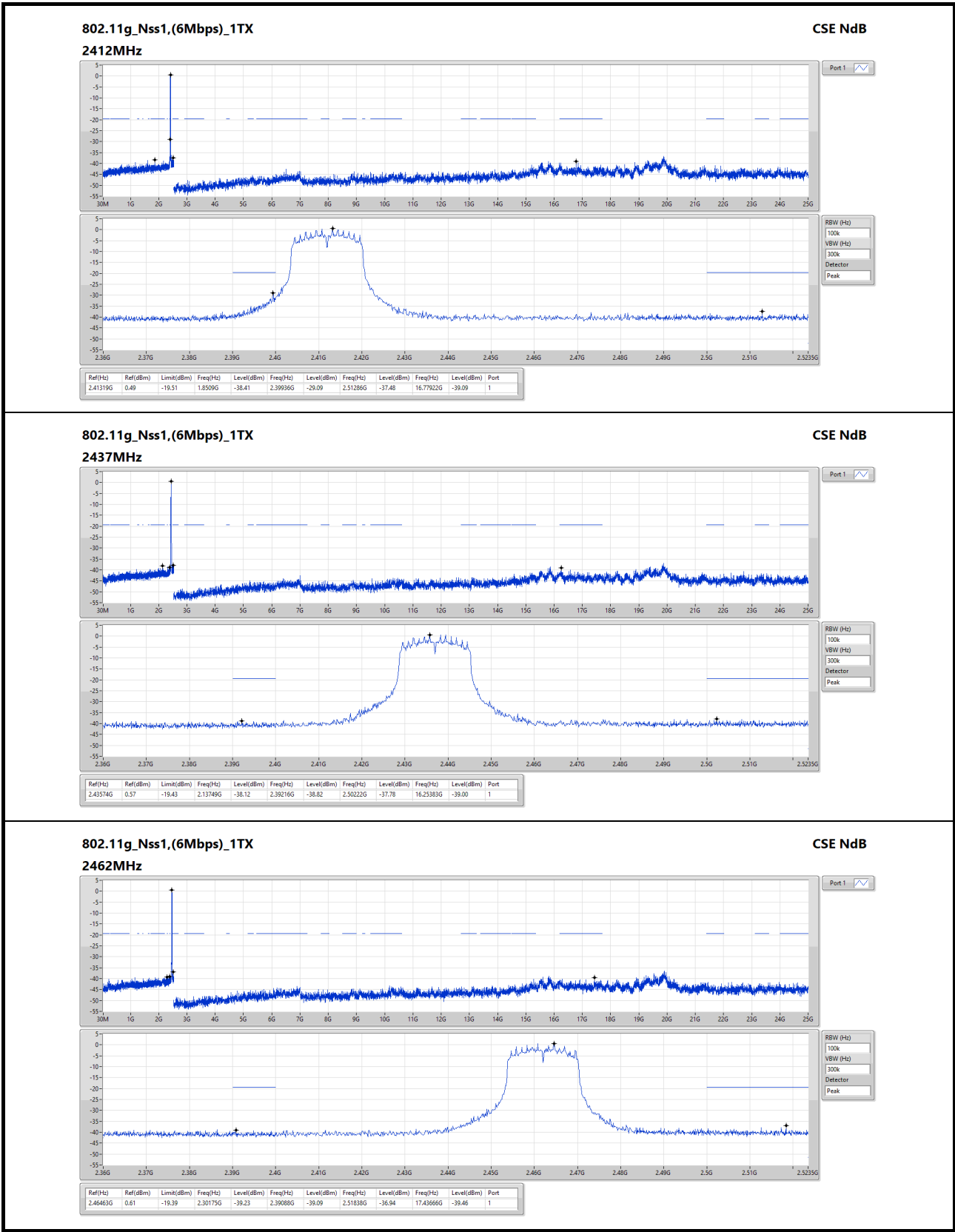

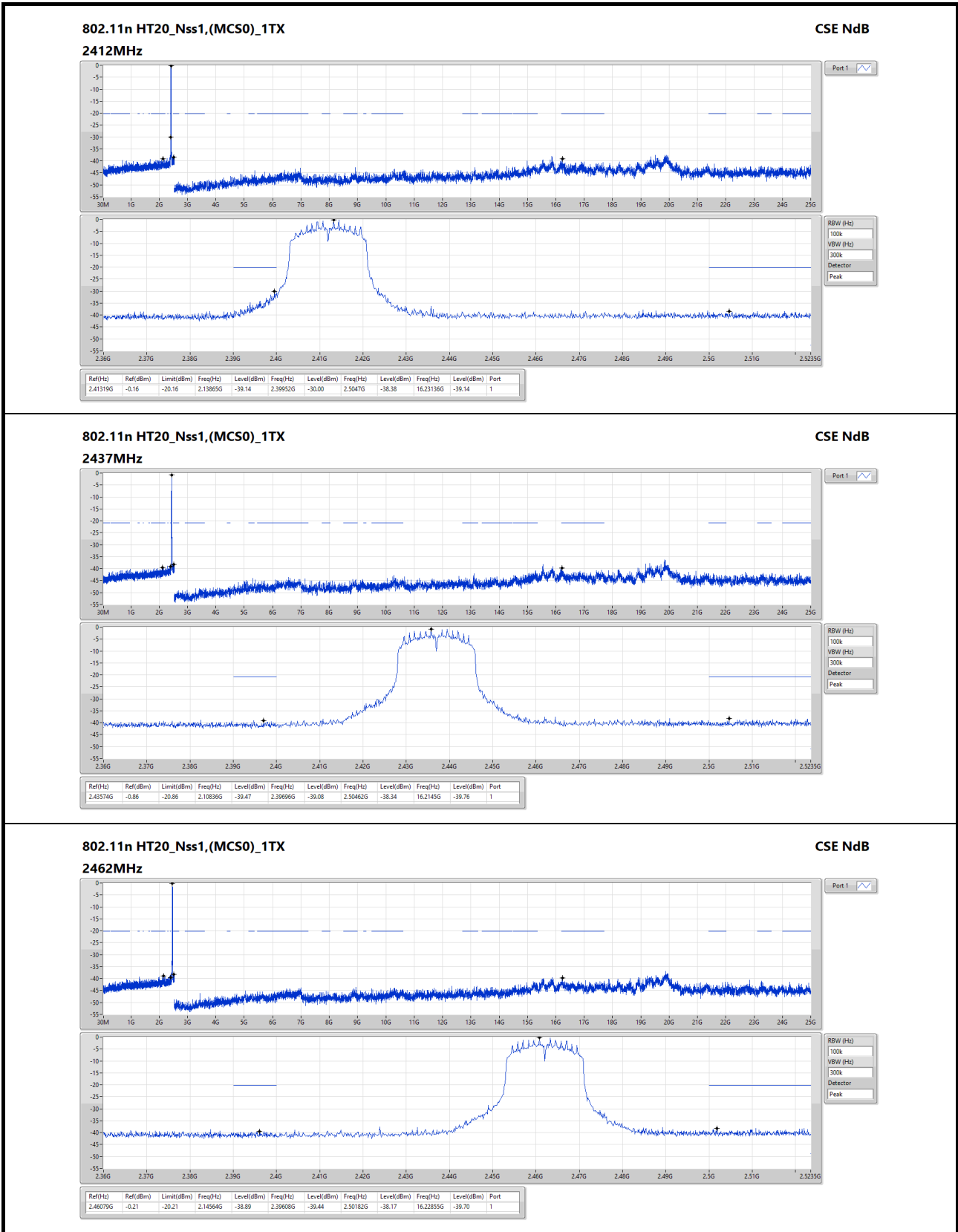

4 Test laboratory information

Established in 2012, ICC provides foremost EMC & RF Testing and advisory consultation services by our skilled engineers and technicians. Our services employ a wide variety of advanced edge test equipment and one of the widest certification extents in the business.

International Certification Corporation (EMC and Wireless Communication Laboratory), it is our definitive objective is to institute long term, trust-based associations with our clients. The expectation we set up with our clients is based on outstanding service, practical expertise and devotion to a certified value structure. Our passion is to grant our clients with best EMC / RF services by oriented knowledgeable and accommodating staff.

Our Test sites are located at Linkou District and Kwei Shan District. Location map can be found on our website <http://www.icertifi.com.tw>.

Linkou

Tel: 886-2-2601-1640

No.30-2, Ding Fwu Tsuen, Lin Kou
District, New Taipei City, Taiwan
(R.O.C.)

Kwei Shan

Tel: 886-3-271-8666

No.3-1, Lane 6, Wen San 3rd
St., Kwei Shan Dist., Tao Yuan
City 33381, Taiwan (R.O.C.)
No.2-1, Lane 6, Wen San 3rd
St., Kwei Shan Dist., Tao Yuan
City 33381, Taiwan (R.O.C.)

Kwei Shan Site II

Tel: 886-3-271-8640

No.14-1, Lane 19, Wen San 3rd
St., Kwei Shan Dist., Tao Yuan
City 333, Taiwan (R.O.C.)

If you have any suggestion, please feel free to contact us as below information.

Tel: 886-3-271-8666

Fax: 886-3-318-0345

Email: ICC_Service@icertifi.com.tw

==END==