

FCC C2PC Test Report

FCC ID : XNAWBS08
Equipment : Withings Body Scan
Model No. : WBS08
Brand Name : Withings
Applicant : Withings
Address : 2 rue Maurice Hartmann
92130 Issy-Les-Moulineaux
France
Standard : 47 CFR FCC Part 15.247
Received Date : Jun. 16, 2023
Tested Date : Jul. 11 ~ Jul. 20, 2023

We, International Certification Corporation, would like to declare that the tested sample has been evaluated and in compliance with the requirement of the above standards. The test results contained in this report refer exclusively to the product. It shall not be reproduced except in full without the written approval of our laboratory.

Reviewed by:

Approved by:



Along Chen / Assistant Manager



Gary Chang / Manager

Table of Contents

1	GENERAL DESCRIPTION	5
1.1	Information.....	5
1.2	Local Support Equipment List	8
1.3	Test Setup Chart	8
1.4	The Equipment List	9
1.5	Test Standards	10
1.6	Reference Guidance	10
1.7	Deviation from Test Standard and Measurement Procedure.....	10
1.8	Measurement Uncertainty	10
2	TEST CONFIGURATION.....	11
2.1	Testing Facility	11
2.2	The Worst Test Modes and Channel Details	11
3	TRANSMITTER TEST RESULTS	12
3.1	Conducted Output Power	12
3.2	Unwanted Emissions into Restricted Frequency Bands	13
3.3	Emissions in Non-Restricted Frequency Bands.....	15
3.4	AC Power Line Conducted Emissions	16
4	TEST LABORATORY INFORMATION	17
Appendix A. Conducted Output Power		
Appendix B. Unwanted Emissions into Restricted Frequency Bands		
Appendix C. Emissions in Non-Restricted Frequency Bands		
Appendix D. AC Power Line Conducted Emissions		

Release Record

Report No.	Version	Description	Issued Date
FR261601-05AC	Rev. 01	Initial issue	Aug. 29, 2023

Summary of Test Results

FCC Rules	Test Items	Measured	Result
15.207	AC Power Line Conducted Emission	[dBuV]: 0.777MHz 33.83 (Margin -12.17dB) - AV	Pass
15.247(d) 15.209	Unwanted Emissions	[dBuV/m at 3m]: 4874.00MHz 45.01 (Margin -8.99dB) - AV	Pass
15.247(b)(3)	Conducted Output Power	Max Power [dBm]: 22.83	Pass
15.203	Antenna Requirement	Meet the requirement of limit	Pass

Declaration of Conformity:

The test results with all measurement uncertainty excluded are presented in accordance with the regulation limits or requirements declared by manufacturers.

Comments and Explanations:

The declared of product specification for EUT presented in the report are provided by the manufacturer, and the manufacturer takes all the responsibilities for the accuracy of product specification.

1 General Description

1.1 Information

This is a Class II Permissive Change report (C2PC).

This report is issued as a supplementary report to original report no. FR261601-04AC. The modifications are concerned with following items:

- Removed reserved components (0 ohms) and relative circuit is modified in non-RF section.
- Filter is replacing.
- Diode is adding and relative circuit is modified in non-RF section.
- Contour of U801 is modified.

In this report, all related test items had been performed and recorded in the following sections.

1.1.1 Specification of the Equipment under Test (EUT)

RF General Information					
Frequency Range (MHz)	IEEE Std. 802.11	Ch. Freq. (MHz)	Channel Number	Transmit Chains (N _{TX})	Data Rate / MCS
2400-2483.5	b	2412-2462	1-11 [11]	1	1-11 Mbps
2400-2483.5	g	2412-2462	1-11 [11]	1	6-54 Mbps
2400-2483.5	n (HT20)	2412-2462	1-11 [11]	1	MCS 0-7

Note 1: RF output power specifies that Maximum Conducted (Average) Output Power.
 Note 2: DSSS-DBPSK, DQPSK, CCK modulation
 OFDM - BPSK, QPSK, 16QAM, 64QAM modulation.

1.1.2 Antenna Details

Ant. No.	Brand	Model	Type	Connector	Gain (dBi)
1	BROADCOM	BCM9Fractal64	PCB	N/A	2.8

1.1.3 Power Supply Type of Equipment under Test (EUT)

Power Supply Type	3.7Vdc from battery 5Vdc from adapter
--------------------------	--

Note: The adapter is not bundled in market.

1.1.4 Accessories

Accessories		
No.	Equipment	Description
1	Cable stopper	---
2	Wall handle support	---
3	USB-C Cable	0.75m non-shielded without core

1.1.5 Test Sample Information

MAC of Test Sample	Radiated Emission: A47EFA12740A AC Power Line Conducted Emission: A47EFA12740A Antenna Port Conducted: A47EFA1273E2
---------------------------	---

1.1.6 Channel List

Channel	Frequency(MHz)
1	2412
2	2417
3	2422
4	2427
5	2432
6	2437
7	2442
8	2447
9	2452
10	2457
11	2462

1.1.7 Test Tool and Duty Cycle

Test Tool	Tera Term, Version: 4.80		
Duty Cycle and Duty Factor	Mode	Duty Cycle (%)	Duty Factor (dB)
	11b	99.32%	0.03
	11g	94.20%	0.26
	HT20	93.85%	0.28

1.1.8 Power Index of Test Tool

Modulation Mode	Test Frequency (MHz)	Power Index
11b	2412	14
11b	2437	14
11b	2462	14
11g	2412	13.5
11g	2437	13.5
11g	2462	13.5
HT20	2412	13.5
HT20	2437	13.5
HT20	2462	13.5

1.2 Local Support Equipment List

Support Equipment List					
No.	Equipment	Brand	Model	FCC ID	Remarks
1	Adapter	Samsung	ETA-U90JWS	---	---

Note: The support notebook and fixture are disconnected from EUT and removed from test table after sending command to EUT to control EUT to transmit continuously.

1.3 Test Setup Chart

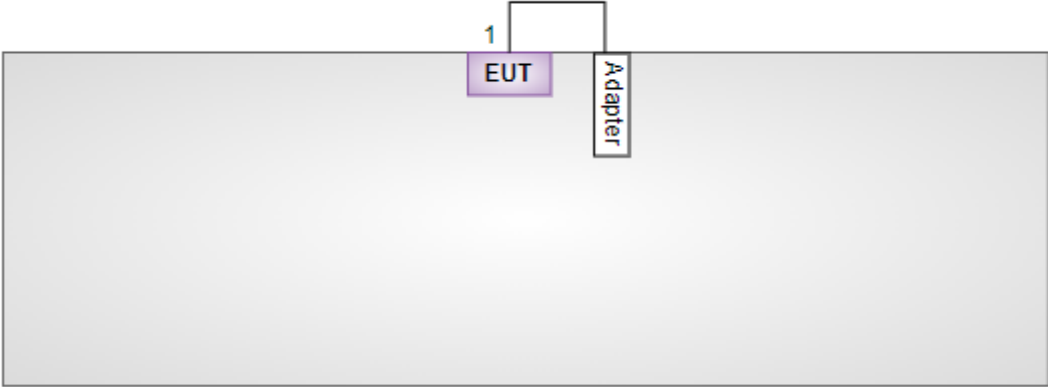
Test Setup Diagram	
 <p>The diagram shows a large grey rectangular area representing the test table. On the top edge of this area, there is a purple box labeled 'EUT' and a white box labeled 'Adapter'. A line connects the top of the 'EUT' box to the top of the 'Adapter' box. A small number '1' is placed above the 'EUT' box, indicating the connection point for the signal cable.</p>	
No.	Signal cable / Length (m)
1	USB-C cable, 0.75m non-shielded without core

1.4 The Equipment List

Test Item	Conducted Emission				
Test Site	Conduction room 1 / (CO01-WS)				
Tested Date	Jul. 20, 2023				
Instrument	Brand	Model No.	Serial No.	Calibration Date	Calibration Until
Receiver	R&S	ESR3	101658	Feb. 17, 2023	Feb. 16, 2024
LISN	R&S	ENV216	101579	May 09, 2023	May 08, 2024
LISN (Support Unit)	SCHWARZBECK	Schwarzbeck 8127	8127667	Jan .03, 2023	Jan .02, 2024
RF Cable-CON	Woken	CFD200-NL	CFD200-NL-001	Oct. 17, 2022	Oct. 16, 2023
50 ohm terminal (Support Unit)	NA	50	01	Jun. 14, 2023	Jun. 13, 2024
Measurement Software	AUDIX	e3	6.120210k	NA	NA
Note: Calibration Interval of instruments listed above is one year.					

Test Item	Radiated Emission				
Test Site	966 chamber3 / (03CH03-WS)				
Tested Date	Jul. 11 ~ Jul. 13, 2023				
Instrument	Brand	Model No.	Serial No.	Calibration Date	Calibration Until
Receiver	R&S	ESR3	101657	Mar. 03, 2023	Mar. 02, 2024
Spectrum Analyzer	R&S	FSV40	101499	Mar. 16, 2023	Mar. 15, 2024
Loop Antenna	R&S	HFH2-Z2	100330	Nov. 01, 2022	Oct. 31, 2023
Bilog Antenna	SCHWARZBECK	VULB9168	VULB9168-685	Jul. 04, 2023	Jul. 03, 2024
Horn Antenna 1G-18G	SCHWARZBECK	BBHA 9120 D	BBHA 9120 D 1206	Dec. 15, 2022	Dec. 14, 2023
Horn Antenna 18G-40G	SCHWARZBECK	BBHA 9170	BBHA 9170517	Oct. 27, 2022	Oct. 26, 2023
Preamplifier	EMC	EMC02325	980187	Jul. 10, 2023	Jul. 09, 2024
Preamplifier	EMC	EMC184045SE	980897	Aug. 01, 2022	Jul. 31, 2023
Preamplifier	EMC	EMC184045SE	980903	Jul. 16, 2022	Jul. 15, 2023
Loop Antenna Cable	KOAX KABEL	101354-BW	101354-BW	Oct. 04, 2022	Oct. 03, 2023
LF cable-0.8M	EMC	EMC8D-NM-NM-800	EMC8D-NM-NM-800-001	Sep. 23, 2022	Sep. 22, 2023
LF cable-3M	EMC	EMC8D-NM-NM-3000	131103	Sep. 23, 2022	Sep. 22, 2023
LF cable-13M	EMC	EMC8D-NM-NM-13000	131104	Sep. 23, 2022	Sep. 22, 2023
RF cable-3M	HUBER+SUHNER	SUCOFLEX104	MY22620/4	Sep. 23, 2022	Sep. 22, 2023
RF cable-8M	EMC	EMC104-SM-SM-8000	181107	Sep. 23, 2022	Sep. 22, 2023
HIGHPASS FILTER	WI	WHK3.1-18G-10SS	43	Sep. 28, 2022	Sep. 27, 2023
Attenuator	Pasternack	PE7005-10	10-3	Oct. 14, 2022	Oct. 13, 2023
Measurement Software	AUDIX	e3	6.120210g	NA	NA
Note: Calibration Interval of instruments listed above is one year.					

Test Item	RF Conducted				
Test Site	(TH01-WS)				
Tested Date	Jul. 19, 2023				
Instrument	Brand	Model No.	Serial No.	Calibration Date	Calibration Until
Spectrum Analyzer	R&S	FSV40	101910	Apr. 14, 2023	Apr. 13, 2024
Power Meter	Anritsu	ML2495A	1241002	Nov. 23, 2022	Nov. 22, 2023
Power Sensor	Anritsu	MA2411B	1207366	Nov. 23, 2022	Nov. 22, 2023
Attenuator	Pasternack	PE7005-10	10-2	Oct. 06, 2022	Oct. 05, 2023
Measurement Software	Sporton	SENSE-15247_DTS	V5.11	NA	NA
Note: Calibration Interval of instruments listed above is one year.					

1.5 Test Standards

47 CFR FCC Part 15.247
ANSI C63.10-2013

1.6 Reference Guidance

FCC KDB 558074 D01 15.247 Meas Guidance v05r02

1.7 Deviation from Test Standard and Measurement Procedure

None

1.8 Measurement Uncertainty

The measurement uncertainties given below are based on a 95% confidence level (based on a coverage factor ($k=2$)).

Measurement Uncertainty	
Parameters	Uncertainty
Bandwidth	± 34.130 Hz
Conducted power	± 0.808 dB
Power density	± 0.583 dB
Conducted emission	± 2.715 dB
AC conducted emission	± 2.92 dB
Unwanted Emission ≤ 1 GHz	± 3.96 dB
Unwanted Emission > 1 GHz	± 4.51 dB

2 Test Configuration

2.1 Testing Facility

Test Laboratory	International Certification Corporation
Test Site	CO01-WS, TH01-WS
Address of Test Site	No.3-1, Lane 6, Wen San 3rd St., Kwei Shan Dist., Tao Yuan City 33381, Taiwan (R.O.C.)
Test Site	03CH03-WS
Address of Test Site	No.14-1, Lane 19, Wen San 3rd St., Kwei Shan Dist., Tao Yuan City 33381, Taiwan (R.O.C.)

- FCC Designation No.: TW0009
- FCC site registration No.: 207696
- ISED#: 10807C
- CAB identifier: TW2732

2.2 The Worst Test Modes and Channel Details

Test item	Modulation Mode	Test Frequency (MHz)	Data Rate	Test Configuration
AC Power Line Conducted Emission	11g	2462	6 Mbps	---
Unwanted Emissions ≤ 1GHz	11g	2462	6 Mbps	---
Unwanted Emissions >1GHz Conducted Output Power	11b 11g HT20	2412 / 2437 / 2462 2412 / 2437 / 2462 2412 / 2437 / 2462	1 Mbps 6 Mbps MCS 0	---

3 Transmitter Test Results

3.1 Conducted Output Power

3.1.1 Limit of Conducted Output Power

Conducted power shall not exceed 1Watt.

Antenna gain \leq 6dBi, no any corresponding reduction is in output power limit.

Antenna gain $>$ 6dBi

Non Fixed, point to point operations.

The conducted output power from the intentional radiator shall be reduced by the amount in dB that the directional gain of the antenna exceeds 6 dB

Fixed, point to point operations

Systems operating in the 2400–2483.5 MHz band that are used exclusively for fixed, point-to-point Operations, maximum peak output power of the intentional radiator is reduced by 1 dB for every 3 dB that the directional gain of the antenna exceeds 6 dBi.

3.1.2 Test Procedures

A broadband RF power meter is used for output power measurement. The video bandwidth of power meter is greater than DTS bandwidth of EUT. If duty cycle of test signal is not 100 %, trigger and gating function of power meter will be enabled to capture transmission burst for measuring output power.

3.1.3 Test Setup

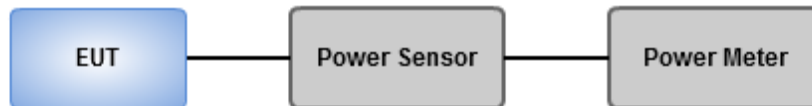

3.1.4 Test Results

Ambient Condition	24°C / 67%	Tested By	Aska Huang
--------------------------	------------	------------------	------------

Refer to Appendix A.

3.2 Unwanted Emissions into Restricted Frequency Bands

3.2.1 Limit of Unwanted Emissions into Restricted Frequency Bands

Restricted Band Emissions Limit			
Frequency Range (MHz)	Field Strength (uV/m)	Field Strength (dBuV/m)	Measure Distance (m)
0.009~0.490	2400/F(kHz)	48.5 - 13.8	300
0.490~1.705	24000/F(kHz)	33.8 - 23	30
1.705~30.0	30	29	30
30~88	100	40	3
88~216	150	43.5	3
216~960	200	46	3
Above 960	500	54	3

Note 1:
Qusai-Peak value is measured for frequency below 1GHz except for 9–90 kHz, 110–490 kHz frequency band. Peak and average value are measured for frequency above 1GHz. The limit on average radio frequency emission is as above table. The limit on peak radio frequency emissions is 20 dB above the maximum permitted average emission limit

Note 2:
Measurements may be performed at a distance other than what is specified provided. When performing measurements at a distance other than that specified, the results shall be extrapolated to the specified distance using an extrapolation factor as below, Frequency at or above 30 MHz: 20 dB/decade Frequency below 30 MHz: 40 dB/decade.

3.2.2 Test Procedures

1. Measurement is made at a semi-anechoic chamber that incorporates a turntable allowing a EUT rotation of 360°. A continuously-rotating, remotely-controlled turntable is installed at the test site to support the EUT and facilitate determination of the direction of maximum radiation for each EUT emission frequency. The EUT is placed at test table. For emissions testing at or below 1 GHz, the table height is 80 cm above the reference ground plane. For emission measurements above 1 GHz, the table height is 1.5 m
2. Measurement is made with the antenna positioned in both the horizontal and vertical planes of polarization. The measurement antenna is varied in height (1m ~ 4m) above the reference ground plane to obtain the maximum signal strength. Distance between EUT and antenna is 3 m.
3. This investigation is performed with the EUT rotated 360°, the antenna height scanned between 1 m and 4 m, and the antenna rotated to repeat the measurements for both the horizontal and vertical antenna polarizations.

Note:

1. 120kHz measurement bandwidth of test receiver and Quasi-peak detector is for radiated emission below 1GHz.
2. RBW=1MHz, VBW=3MHz and Peak detector is for peak measured value of radiated emission above 1GHz.
3. RBW=1MHz, VBW=1/T and Peak detector is for average measured value of radiated emission above 1GHz.

3.2.3 Test Setup

Radiated Emissions below 1 GHz

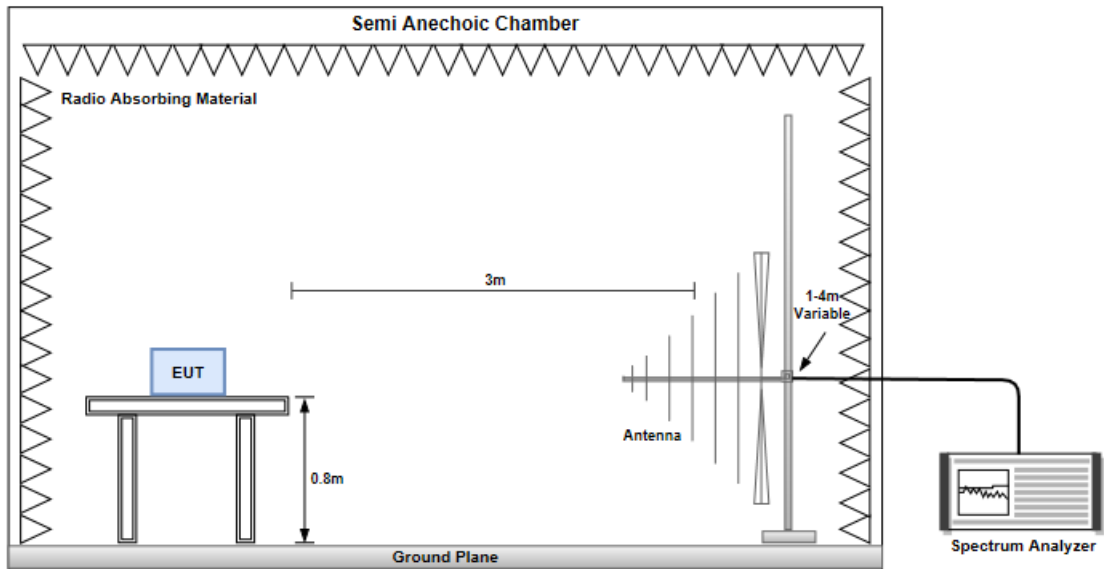

Radiated Emissions above 1 GHz

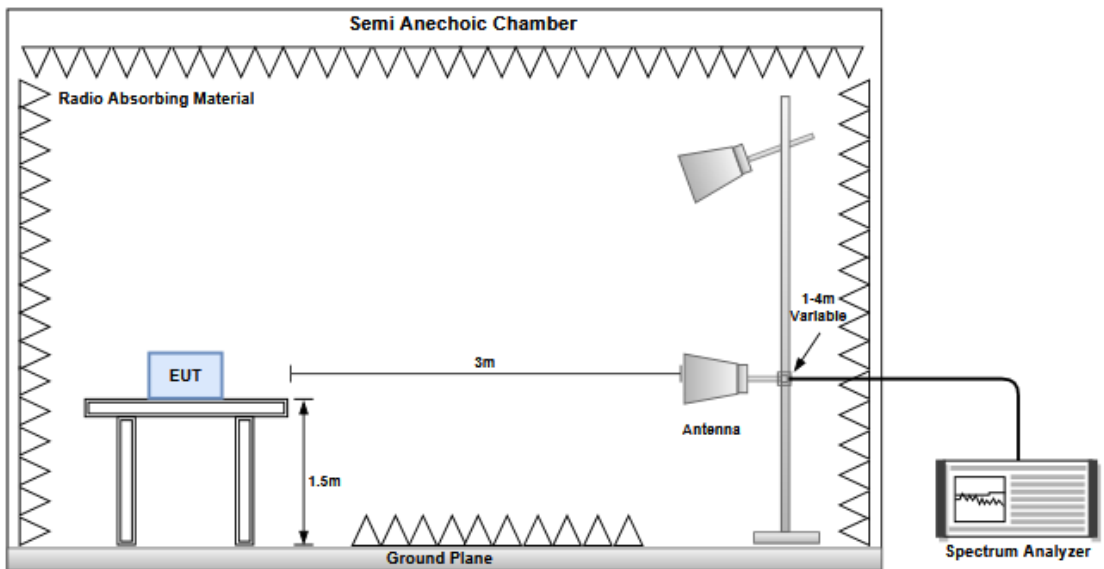

3.2.4 Test Results

Refer to Appendix B.

3.3 Emissions in Non-Restricted Frequency Bands

3.3.1 Emissions in Non-Restricted Frequency Bands Limit

Peak power in any 100 kHz bandwidth outside of the authorized frequency band shall be attenuated by at least 20 dB relative to the maximum in-band peak PSD level in 100 kHz.

3.3.2 Test Procedures

Reference level measurement

1. Set RBW=100kHz, VBW = 300kHz , Detector = Peak, Sweep time = Auto
2. Trace = max hold , Allow Trace to fully stabilize
3. Use the peak marker function to determine the maximum PSD level

Emission level measurement

1. Set RBW=100kHz, VBW = 300kHz , Detector = Peak, Sweep time = Auto
2. Trace = max hold , Allow Trace to fully stabilize
3. Scan Frequency range is up to 25GHz
4. Use the peak marker function to determine the maximum amplitude level

3.3.3 Test Setup

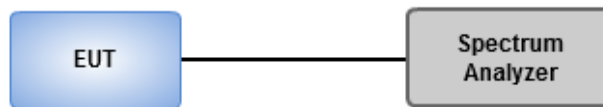

3.3.4 Test Results

Ambient Condition	24°C / 67%	Tested By	Aska Huang
--------------------------	------------	------------------	------------

Refer to Appendix C.

3.4 AC Power Line Conducted Emissions

3.4.1 Limit of AC Power Line Conducted Emissions

Conducted Emissions Limit		
Frequency Emission (MHz)	Quasi-Peak	Average
0.15-0.5	66 - 56 *	56 - 46 *
0.5-5	56	46
5-30	60	50

Note 1: * Decreases with the logarithm of the frequency.

3.4.2 Test Procedures

1. The device is placed on a test table, raised 80 cm above the reference ground plane. The vertical conducting plane is located 40 cm to the rear of the device.
2. The device is connected to line impedance stabilization network (LISN) and other accessories are connected to other LISN. Measured levels of AC power line conducted emission are across the 50 Ω LISN port.
3. AC conducted emission measurements is made over frequency range from 150 kHz to 30 MHz.
4. This measurement was performed with AC 120V / 60Hz.

3.4.3 Test Setup

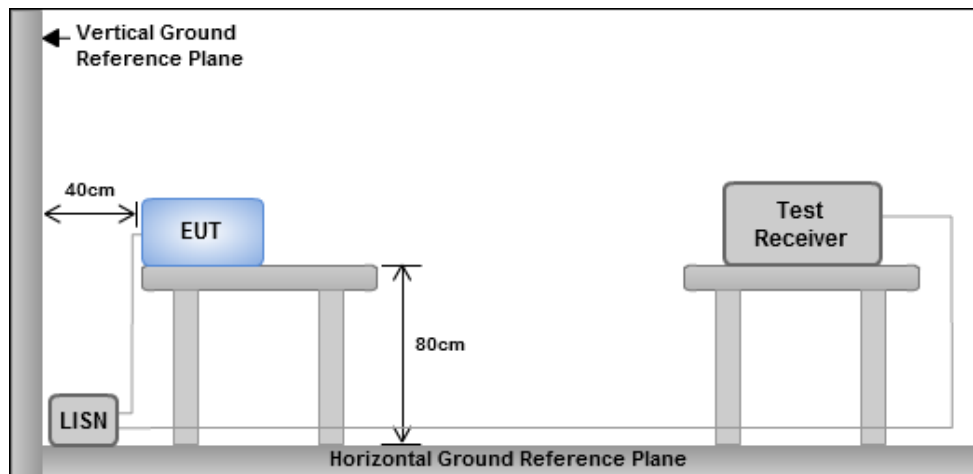

- Note: 1. Support units were connected to second LISN.
 2. Both of LISNs (AMN) are 80 cm from EUT and at least 80 cm from other units and other metal planes

3.4.4 Test Results

Refer to Appendix D.

4 Test laboratory information

Established in 2012, ICC provides foremost EMC & RF Testing and advisory consultation services by our skilled engineers and technicians. Our services employ a wide variety of advanced edge test equipment and one of the widest certification extents in the business.

International Certification Corporation (EMC and Wireless Communication Laboratory), it is our definitive objective is to institute long term, trust-based associations with our clients. The expectation we set up with our clients is based on outstanding service, practical expertise and devotion to a certified value structure. Our passion is to grant our clients with best EMC / RF services by oriented knowledgeable and accommodating staff.

Our Test sites are located at Linkou District and Kwei Shan District. Location map can be found on our website <http://www.icertifi.com.tw>.

Linkou

Tel: 886-2-2601-1640

No.30-2, Ding Fwu Tsuen, Lin Kou
District, New Taipei City, Taiwan
(R.O.C.)

Kwei Shan

Tel: 886-3-271-8666

No.3-1, Lane 6, Wen San 3rd
St., Kwei Shan Dist., Tao Yuan
City 33381, Taiwan (R.O.C.)
No.2-1, Lane 6, Wen San 3rd
St., Kwei Shan Dist., Tao Yuan
City 33381, Taiwan (R.O.C.)

Kwei Shan Site II

Tel: 886-3-271-8640

No.14-1, Lane 19, Wen San 3rd
St., Kwei Shan Dist., Tao Yuan
City 33381, Taiwan (R.O.C.)

If you have any suggestion, please feel free to contact us as below information.

Tel: 886-3-271-8666

Fax: 886-3-318-0345

Email: ICC_Service@icertifi.com.tw

==END==



Conducted Output Power(Peak)

Appendix A.1

Summary

Mode	Total Power (dBm)	Total Power (W)
2.4-2.4835GHz	-	-
802.11b_Nss1,(1Mbps)_1TX	16.75	0.04732
802.11g_Nss1,(6Mbps)_1TX	22.83	0.19187
802.11n HT20_Nss1,(MCS0)_1TX	22.62	0.18281

Result

Mode	Result	DG (dBi)	Port 1 (dBm)	Total Power (dBm)	Power Limit (dBm)	EIRP (dBm)	EIRP Limit (dBm)
802.11b_Nss1,(1Mbps)_1TX	-	-	-	-	-	-	-
2412MHz	Pass	2.80	16.75	16.75	30.00	19.55	36.00
2437MHz	Pass	2.80	16.71	16.71	30.00	19.51	36.00
2462MHz	Pass	2.80	16.72	16.72	30.00	19.52	36.00
802.11g_Nss1,(6Mbps)_1TX	-	-	-	-	-	-	-
2412MHz	Pass	2.80	22.59	22.59	30.00	25.39	36.00
2437MHz	Pass	2.80	22.83	22.83	30.00	25.63	36.00
2462MHz	Pass	2.80	22.65	22.65	30.00	25.45	36.00
802.11n HT20_Nss1,(MCS0)_1TX	-	-	-	-	-	-	-
2412MHz	Pass	2.80	22.56	22.56	30.00	25.36	36.00
2437MHz	Pass	2.80	22.62	22.62	30.00	25.42	36.00
2462MHz	Pass	2.80	22.39	22.39	30.00	25.19	36.00

DG = Directional Gain; Port X = Port X output power



Conducted Output Power(Average)

Appendix A.2

Summary

Mode	Total Power (dBm)	Total Power (W)
2.4-2.4835GHz	-	-
802.11b_Nss1,(1Mbps)_1TX	14.39	0.02748
802.11g_Nss1,(6Mbps)_1TX	14.11	0.02576
802.11n HT20_Nss1,(MCS0)_1TX	14.02	0.02523

Result

Mode	Result	DG (dBi)	Port 1 (dBm)	Total Power (dBm)	Power Limit (dBm)	EIRP (dBm)	EIRP Limit (dBm)
802.11b_Nss1,(1Mbps)_1TX	-	-	-	-	-	-	-
2412MHz	Pass	2.80	14.39	14.39	-	17.19	-
2437MHz	Pass	2.80	14.36	14.36	-	17.16	-
2462MHz	Pass	2.80	14.37	14.37	-	17.17	-
802.11g_Nss1,(6Mbps)_1TX	-	-	-	-	-	-	-
2412MHz	Pass	2.80	14.07	14.07	-	16.87	-
2437MHz	Pass	2.80	14.11	14.11	-	16.91	-
2462MHz	Pass	2.80	14.01	14.01	-	16.81	-
802.11n HT20_Nss1,(MCS0)_1TX	-	-	-	-	-	-	-
2412MHz	Pass	2.80	14	14.00	-	16.80	-
2437MHz	Pass	2.80	14.02	14.02	-	16.82	-
2462MHz	Pass	2.80	14.01	14.01	-	16.81	-

DG = Directional Gain; Port X = Port X output power

Note : Conducted average output power is for reference



Unwanted Emissions (Below 1GHz)

Modulation	11b	Test Freq. (MHz)	2437
Polarization	Horizontal		

Test By :Brad Wu Temperature(°C):23 Humidity(%):65

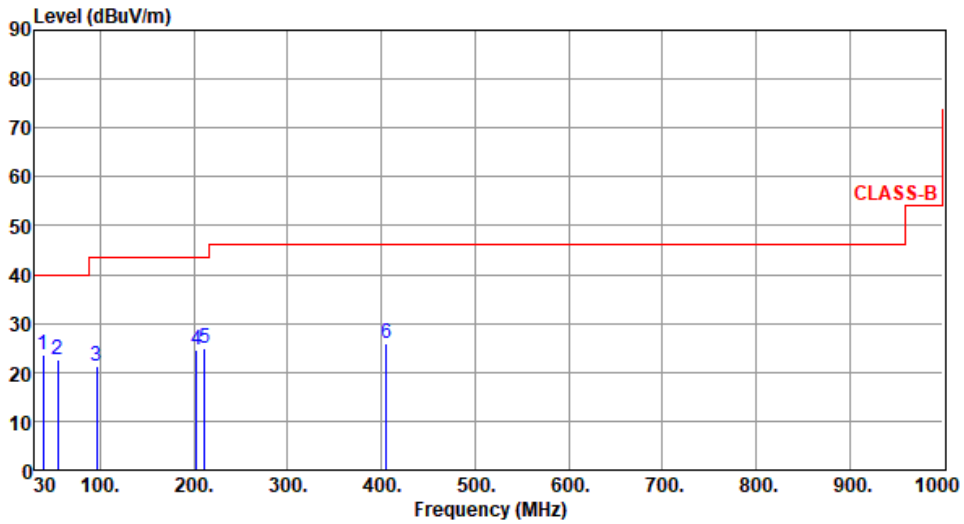

	Freq. MHz	Emission level dBuV/m	Limit dBuV/m	Margin dB	SA reading dBuV	Factor dB/m	Remark	ANT High cm	Turn Table deg
1	38.73	23.56	40.00	-16.44	32.45	-8.89	Peak	---	---
2	54.25	22.55	40.00	-17.45	30.58	-8.03	Peak	---	---
3	95.96	21.31	43.50	-22.19	34.90	-13.59	Peak	---	---
4	202.66	24.51	43.50	-18.99	36.33	-11.82	Peak	---	---
5	211.39	24.78	43.50	-18.72	36.64	-11.86	Peak	---	---
6	405.39	25.89	46.00	-20.11	30.71	-4.82	Peak	---	---

Note 1: Emission Level (dBuV/m) = SA Reading (dBuV) + Factor* (dB/m)

*Factor includes antenna factor , cable loss and amplifier gain

Note 2: Margin (dB) = Emission level (dBuV/m) – Limit (dBuV/m).

Note 3: All spurious emissions below 30MHz are more than 20 dB below the limit.



Modulation	11b	Test Freq. (MHz)	2437
Polarization	Vertical		

Test By :Brad Wu Temperature(°C):23 Humidity(%):65

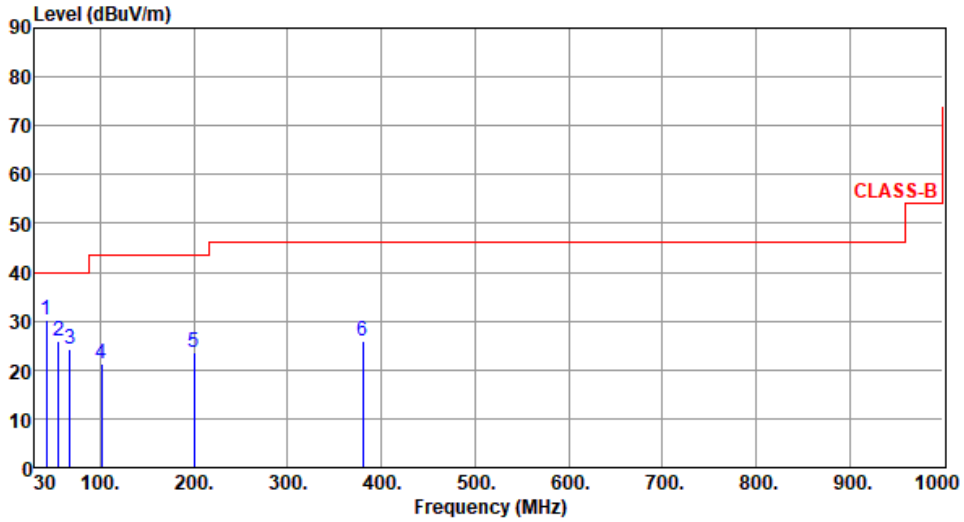

	Freq. MHz	Emission level dBuV/m	Limit dBuV/m	Margin dB	SA reading dBuV	Factor dB/m	Remark	ANT High cm	Turn Table deg
1	42.61	30.24	40.00	-9.76	38.46	-8.22	Peak	---	---
2	55.22	25.93	40.00	-14.07	34.27	-8.34	Peak	---	---
3	67.83	24.24	40.00	-15.76	34.64	-10.40	Peak	---	---
4	101.78	21.22	43.50	-22.28	33.99	-12.77	Peak	---	---
5	199.75	23.64	43.50	-19.86	35.42	-11.78	Peak	---	---
6	380.17	26.06	46.00	-19.94	31.54	-5.48	Peak	---	---

Note 1: Emission Level (dBuV/m) = SA Reading (dBuV) + Factor* (dB/m)

*Factor includes antenna factor , cable loss and amplifier gain

Note 2: Margin (dB) = Emission level (dBuV/m) – Limit (dBuV/m).

Note 3: All spurious emissions below 30MHz are more than 20 dB below the limit.



Unwanted Emission (Above 1GHz) for 11b

Modulation	11b	Test Freq. (MHz)	2412
Polarization	Horizontal		

Test By :Akun Chung Temperature(°C):25 Humidity(%):65

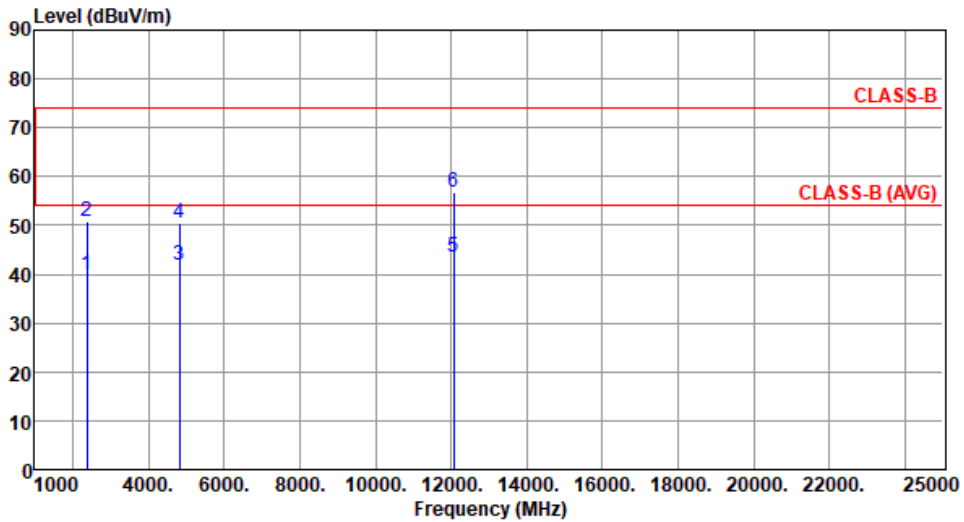

	Freq. MHz	Emission level dBUV/m	Limit dBUV/m	Margin dB	SA reading dBUV	Factor dB/m	Remark	ANT High cm	Turn Table deg
1	2390.00	39.78	54.00	-14.22	43.57	-3.79	Average	115	327
2	2390.00	50.98	74.00	-23.02	54.77	-3.79	Peak	115	327
3	4824.00	42.00	54.00	-12.00	41.88	0.12	Average	302	248
4	4824.00	50.37	74.00	-23.63	50.25	0.12	Peak	302	248
5	12060.00	43.46	54.00	-10.54	35.66	7.80	Average	100	254
6	12060.00	56.67	74.00	-17.33	48.87	7.80	Peak	100	254

Note 1: Emission Level (dBUV/m) = SA Reading (dBUV) + Factor* (dB/m)

*Factor includes antenna factor , cable loss and amplifier gain

Note 2: Margin (dB) = Emission level (dBUV/m) – Limit (dBUV/m).



Modulation	11b	Test Freq. (MHz)	2412
Polarization	Vertical		

Test By :Akun Chung Temperature(°C):25 Humidity(%):65

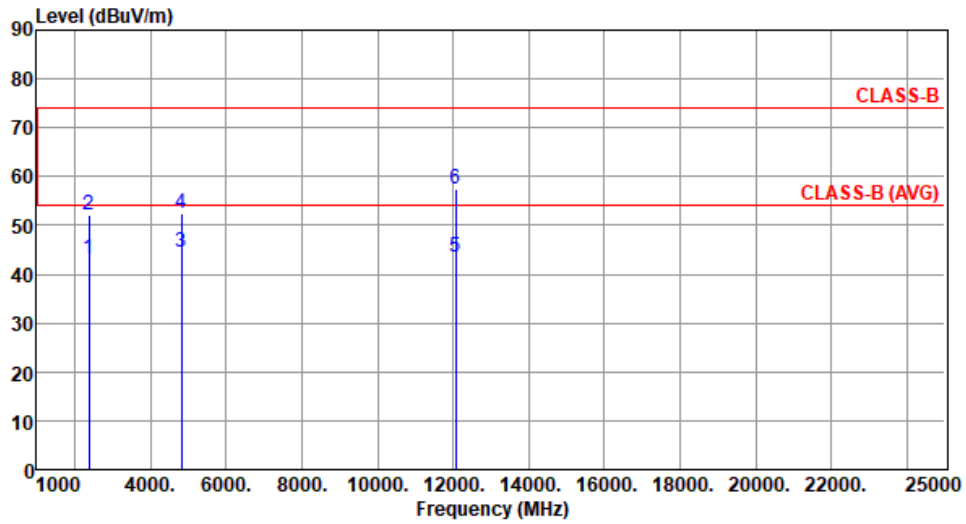

	Freq. MHz	Emission level dBUV/m	Limit dBUV/m	Margin dB	SA reading dBUV	Factor dB/m	Remark	ANT High cm	Turn Table deg
1	2390.00	43.06	54.00	-10.94	46.85	-3.79	Average	334	65
2	2390.00	52.09	74.00	-21.91	55.88	-3.79	Peak	334	65
3	4824.00	44.63	54.00	-9.37	44.51	0.12	Average	342	345
4	4824.00	52.44	74.00	-21.56	52.32	0.12	Peak	342	345
5	12060.00	43.58	54.00	-10.42	35.78	7.80	Average	100	350
6	12060.00	57.49	74.00	-16.51	49.69	7.80	Peak	100	350

Note 1: Emission Level (dBUV/m) = SA Reading (dBUV) + Factor* (dB/m)

*Factor includes antenna factor , cable loss and amplifier gain

Note 2: Margin (dB) = Emission level (dBUV/m) – Limit (dBUV/m).



Modulation	11b	Test Freq. (MHz)	2437
Polarization	Horizontal		

Test By : Akun Chung Temperature(°C): 25 Humidity(%): 65

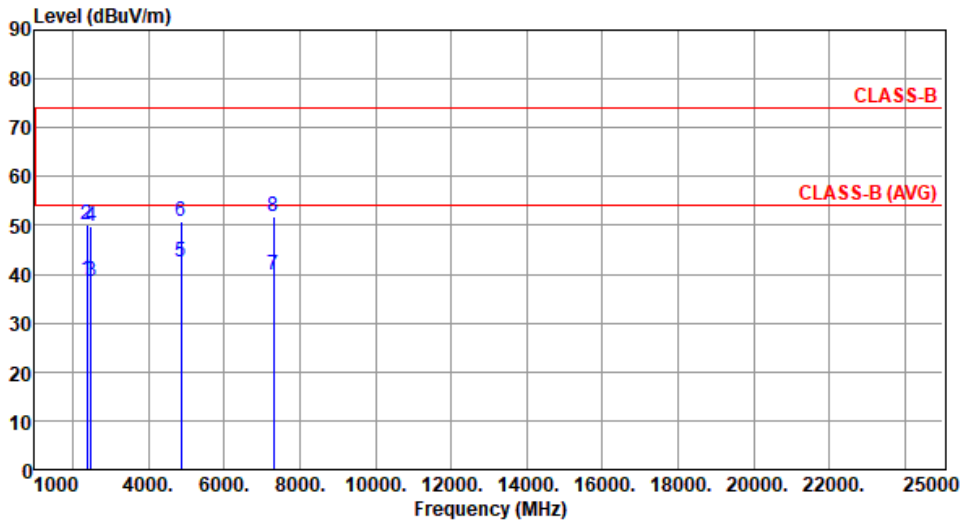

	Freq. MHz	Emission level dBuV/m	Limit dBuV/m	Margin dB	SA reading dBuV	Factor dB/m	Remark	ANT High cm	Turn Table deg
1	2390.00	38.90	54.00	-15.10	42.69	-3.79	Average	108	321
2	2390.00	50.06	74.00	-23.94	53.85	-3.79	Peak	108	321
3	2483.50	38.50	54.00	-15.50	42.59	-4.09	Average	108	321
4	2483.50	49.67	74.00	-24.33	53.76	-4.09	Peak	108	321
5	4874.00	42.37	54.00	-11.63	42.25	0.12	Average	307	241
6	4874.00	50.91	74.00	-23.09	50.79	0.12	Peak	307	241
7	7311.00	39.83	54.00	-14.17	33.89	5.94	Average	120	325
8	7311.00	51.79	74.00	-22.21	45.85	5.94	Peak	120	325

Note 1: Emission Level (dBuV/m) = SA Reading (dBuV) + Factor* (dB/m)

*Factor includes antenna factor , cable loss and amplifier gain

Note 2: Margin (dB) = Emission level (dBuV/m) – Limit (dBuV/m).



Modulation	11b	Test Freq. (MHz)	2437
Polarization	Vertical		

Test By :Akun Chung Temperature(°C):25 Humidity(%):65

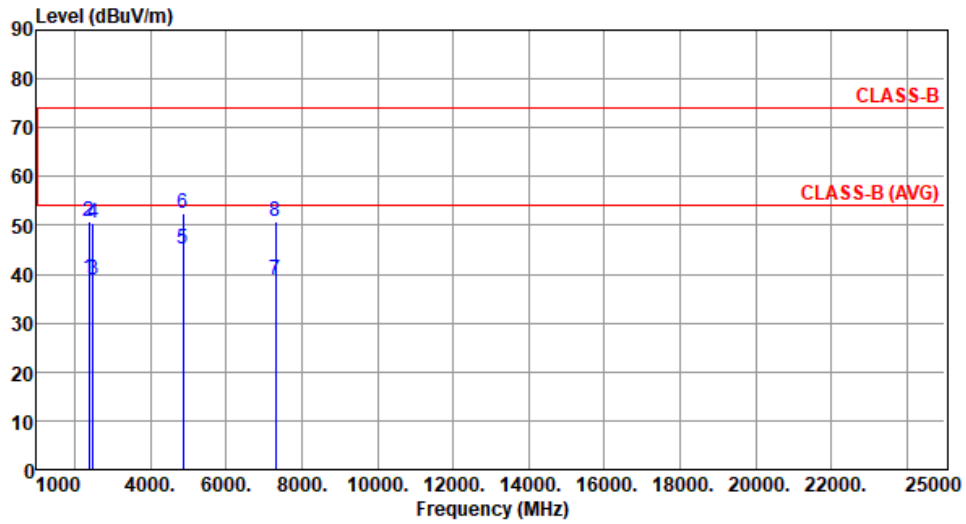

	Freq. MHz	Emission level dBuV/m	Limit dBuV/m	Margin dB	SA reading dBuV	Factor dB/m	Remark	ANT High cm	Turn Table deg
1	2390.00	39.16	54.00	-14.84	42.95	-3.79	Average	320	63
2	2390.00	50.98	74.00	-23.02	54.77	-3.79	Peak	320	63
3	2483.50	38.80	54.00	-15.20	42.89	-4.09	Average	320	63
4	2483.50	50.63	74.00	-23.37	54.72	-4.09	Peak	320	63
5	4874.00	45.01	54.00	-8.99	44.89	0.12	Average	339	341
6	4874.00	52.55	74.00	-21.45	52.43	0.12	Peak	339	341
7	7311.00	38.89	54.00	-15.11	32.95	5.94	Average	100	342
8	7311.00	50.72	74.00	-23.28	44.78	5.94	Peak	100	342

Note 1: Emission Level (dBuV/m) = SA Reading (dBuV) + Factor* (dB/m)

*Factor includes antenna factor , cable loss and amplifier gain

Note 2: Margin (dB) = Emission level (dBuV/m) – Limit (dBuV/m).



Modulation	11b	Test Freq. (MHz)	2462
Polarization	Horizontal		

Test By : Akun Chung Temperature(°C): 25 Humidity(%): 65

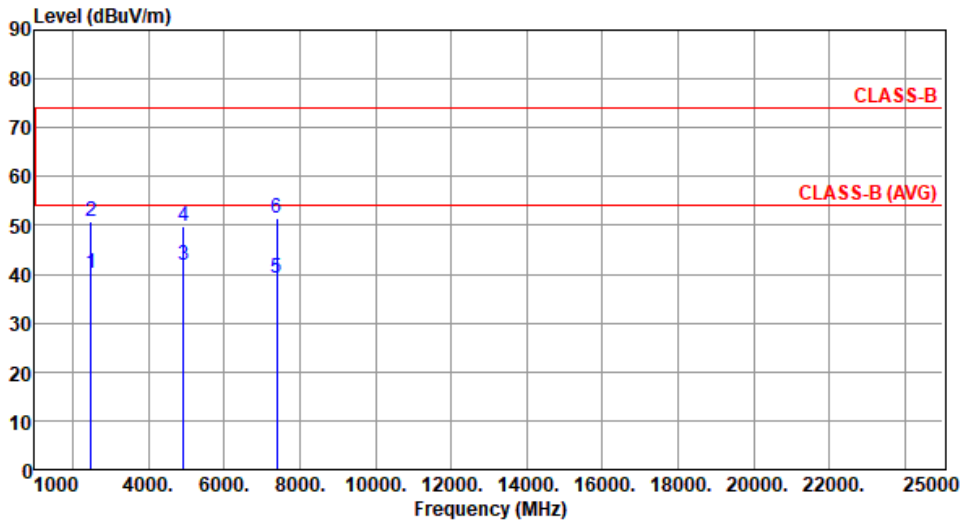

	Freq. MHz	Emission level dBuV/m	Limit dBuV/m	Margin dB	SA reading dBuV	Factor dB/m	Remark	ANT High cm	Turn Table deg
1	2483.50	40.06	54.00	-13.94	44.15	-4.09	Average	128	326
2	2483.50	50.78	74.00	-23.22	54.87	-4.09	Peak	128	326
3	4924.00	41.96	54.00	-12.04	41.88	0.08	Average	299	239
4	4924.00	49.96	74.00	-24.04	49.88	0.08	Peak	299	239
5	7386.00	39.30	54.00	-14.70	33.41	5.89	Average	115	329
6	7386.00	51.55	74.00	-22.45	45.66	5.89	Peak	115	329

Note 1: Emission Level (dBuV/m) = SA Reading (dBuV) + Factor* (dB/m)

*Factor includes antenna factor , cable loss and amplifier gain

Note 2: Margin (dB) = Emission level (dBuV/m) – Limit (dBuV/m).



Modulation	11b	Test Freq. (MHz)	2462
Polarization	Vertical		

Test By :Akun Chung Temperature(°C):25 Humidity(%):65

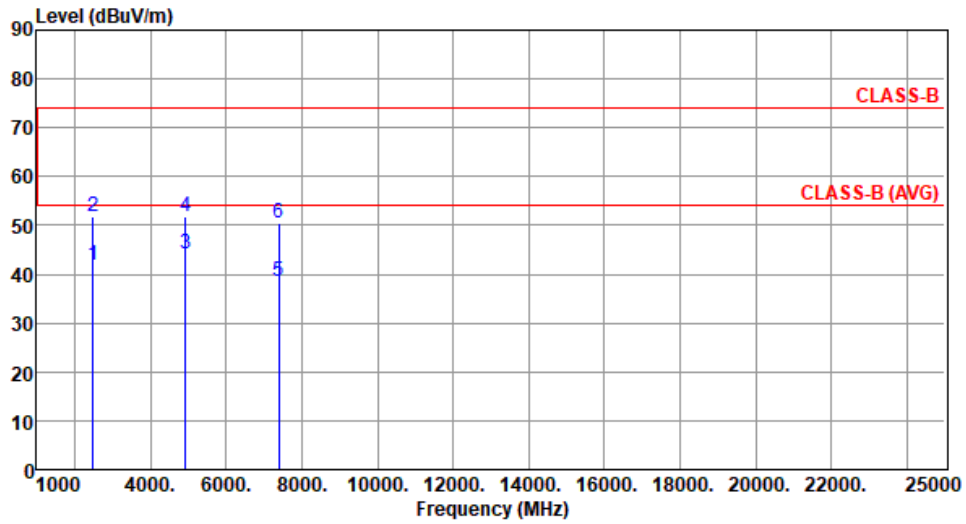

	Freq. MHz	Emission level dBuV/m	Limit dBuV/m	Margin dB	SA reading dBuV	Factor dB/m	Remark	ANT High cm	Turn Table deg
1	2483.50	41.86	54.00	-12.14	45.95	-4.09	Average	350	64
2	2483.50	51.79	74.00	-22.21	55.88	-4.09	Peak	350	64
3	4924.00	44.06	54.00	-9.94	43.98	0.08	Average	345	350
4	4924.00	51.68	74.00	-22.32	51.60	0.08	Peak	345	350
5	7386.00	38.67	54.00	-15.33	32.78	5.89	Average	100	349
6	7386.00	50.54	74.00	-23.46	44.65	5.89	Peak	100	349

Note 1: Emission Level (dBuV/m) = SA Reading (dBuV) + Factor* (dB/m)

*Factor includes antenna factor , cable loss and amplifier gain

Note 2: Margin (dB) = Emission level (dBuV/m) – Limit (dBuV/m).



Unwanted Emissions (Above 1GHz) for 11g

Modulation	11g	Test Freq. (MHz)	2412
Polarization	Horizontal		

Test By :Akun Chung Temperature(°C):25 Humidity(%):65

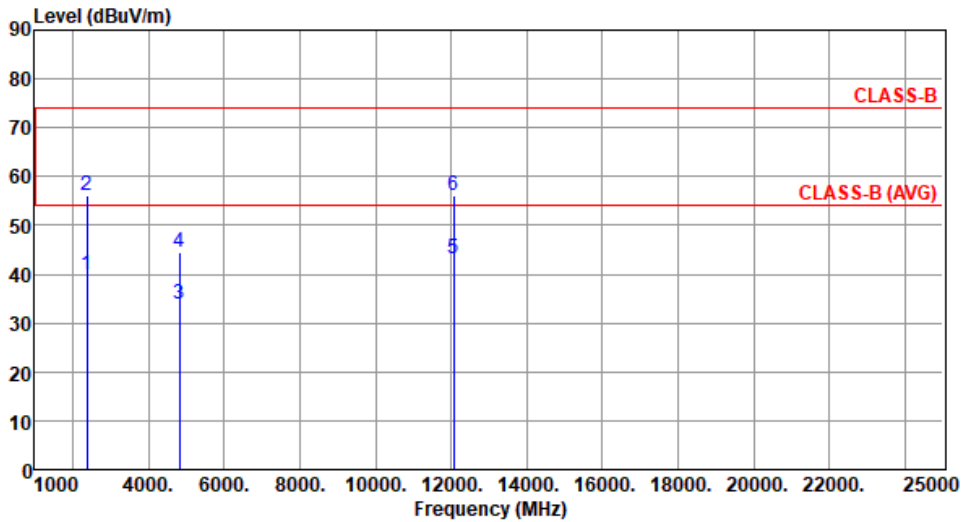

	Freq. MHz	Emission level dBuV/m	Limit dBuV/m	Margin dB	SA reading dBuV	Factor dB/m	Remark	ANT High cm	Turn Table deg
1	2390.00	39.86	54.00	-14.14	43.65	-3.79	Average	102	333
2	2390.00	56.09	74.00	-17.91	59.88	-3.79	Peak	102	333
3	4824.00	33.77	54.00	-20.23	33.65	0.12	Average	317	251
4	4824.00	44.39	74.00	-29.61	44.27	0.12	Peak	317	251
5	12060.00	43.28	54.00	-10.72	35.48	7.80	Average	100	258
6	12060.00	56.28	74.00	-17.72	48.48	7.80	Peak	100	258

Note 1: Emission Level (dBuV/m) = SA Reading (dBuV) + Factor* (dB/m)

*Factor includes antenna factor , cable loss and amplifier gain

Note 2: Margin (dB) = Emission level (dBuV/m) – Limit (dBuV/m).



Modulation	11g	Test Freq. (MHz)	2412
Polarization	Vertical		

Test By : Akun Chung Temperature(°C): 25 Humidity(%): 65

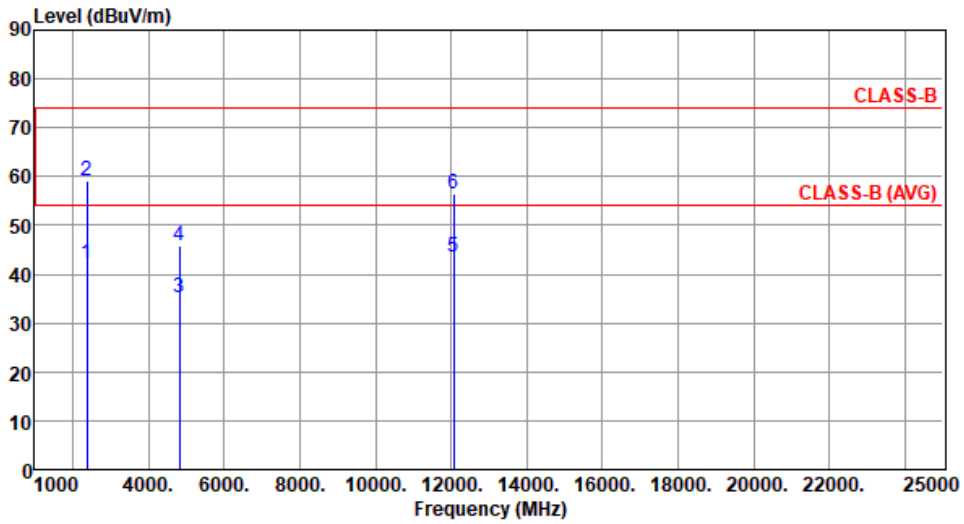

	Freq. MHz	Emission level dBuV/m	Limit dBuV/m	Margin dB	SA reading dBuV	Factor dB/m	Remark	ANT High cm	Turn Table deg
1	2390.00	42.26	54.00	-11.74	46.05	-3.79	Average	322	82
2	2390.00	59.08	74.00	-14.92	62.87	-3.79	Peak	322	82
3	4824.00	35.22	54.00	-18.78	35.10	0.12	Average	298	352
4	4824.00	45.74	74.00	-28.26	45.62	0.12	Peak	298	352
5	12060.00	43.43	54.00	-10.57	35.63	7.80	Average	100	342
6	12060.00	56.49	74.00	-17.51	48.69	7.80	Peak	100	342

Note 1: Emission Level (dBuV/m) = SA Reading (dBuV) + Factor* (dB/m)

*Factor includes antenna factor , cable loss and amplifier gain

Note 2: Margin (dB) = Emission level (dBuV/m) – Limit (dBuV/m).



Modulation	11g	Test Freq. (MHz)	2437
Polarization	Horizontal		

Test By :Akun Chung Temperature(°C):25 Humidity(%):65

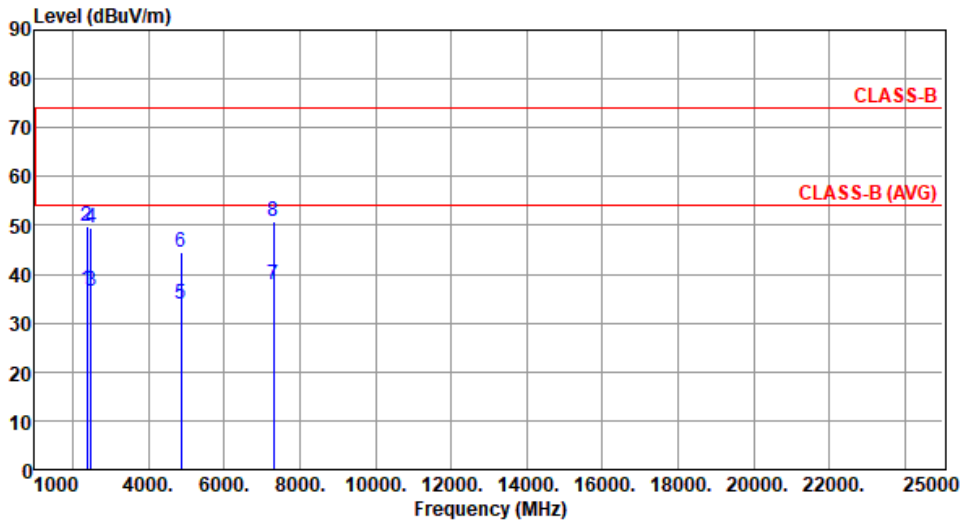

	Freq. MHz	Emission level dBuV/m	Limit dBuV/m	Margin dB	SA reading dBuV	Factor dB/m	Remark	ANT High cm	Turn Table deg
1	2390.00	36.87	54.00	-17.13	40.66	-3.79	Average	112	318
2	2390.00	49.69	74.00	-24.31	53.48	-3.79	Peak	112	318
3	2483.50	36.50	54.00	-17.50	40.59	-4.09	Average	112	318
4	2483.50	49.36	74.00	-24.64	53.45	-4.09	Peak	112	318
5	4874.00	33.91	54.00	-20.09	33.79	0.12	Average	305	242
6	4874.00	44.55	74.00	-29.45	44.43	0.12	Peak	305	242
7	7311.00	37.81	54.00	-16.19	31.87	5.94	Average	100	323
8	7311.00	50.82	74.00	-23.18	44.88	5.94	Peak	100	323

Note 1: Emission Level (dBuV/m) = SA Reading (dBuV) + Factor* (dB/m)

*Factor includes antenna factor , cable loss and amplifier gain

Note 2: Margin (dB) = Emission level (dBuV/m) – Limit (dBuV/m).



Modulation	11g	Test Freq. (MHz)	2437
Polarization	Vertical		

Test By :Akun Chung Temperature(°C):25 Humidity(%):65

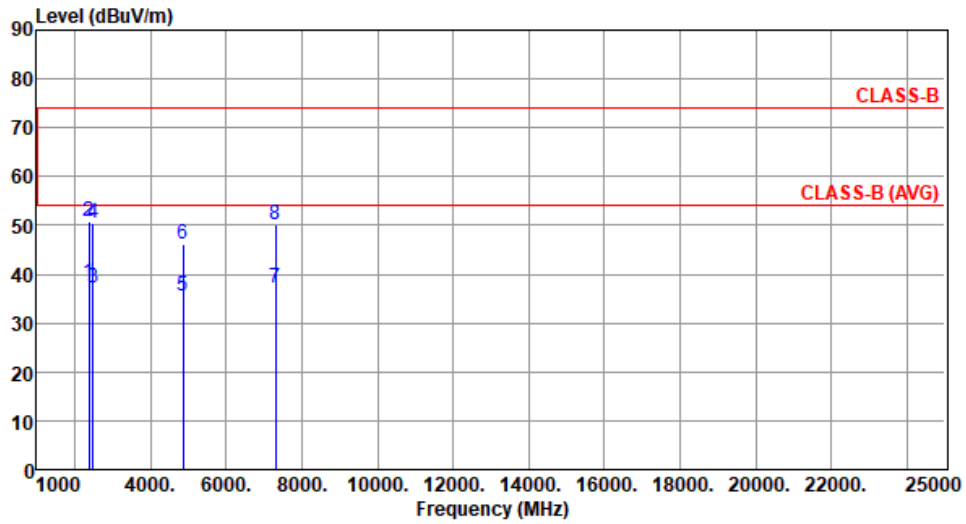

	Freq. MHz	Emission level dBuV/m	Limit dBuV/m	Margin dB	SA reading dBuV	Factor dB/m	Remark	ANT High cm	Turn Table deg
1	2390.00	38.08	54.00	-15.92	41.87	-3.79	Average	308	68
2	2390.00	50.93	74.00	-23.07	54.72	-3.79	Peak	308	68
3	2483.50	37.31	54.00	-16.69	41.40	-4.09	Average	308	68
4	2483.50	50.54	74.00	-23.46	54.63	-4.09	Peak	308	68
5	4874.00	35.38	54.00	-18.62	35.26	0.12	Average	307	356
6	4874.00	46.01	74.00	-27.99	45.89	0.12	Peak	307	356
7	7311.00	37.27	54.00	-16.73	31.33	5.94	Average	100	338
8	7311.00	50.30	74.00	-23.70	44.36	5.94	Peak	100	338

Note 1: Emission Level (dBuV/m) = SA Reading (dBuV) + Factor* (dB/m)

*Factor includes antenna factor , cable loss and amplifier gain

Note 2: Margin (dB) = Emission level (dBuV/m) – Limit (dBuV/m).



Modulation	11g	Test Freq. (MHz)	2462
Polarization	Horizontal		

Test By : Akun Chung Temperature(°C): 25 Humidity(%): 65

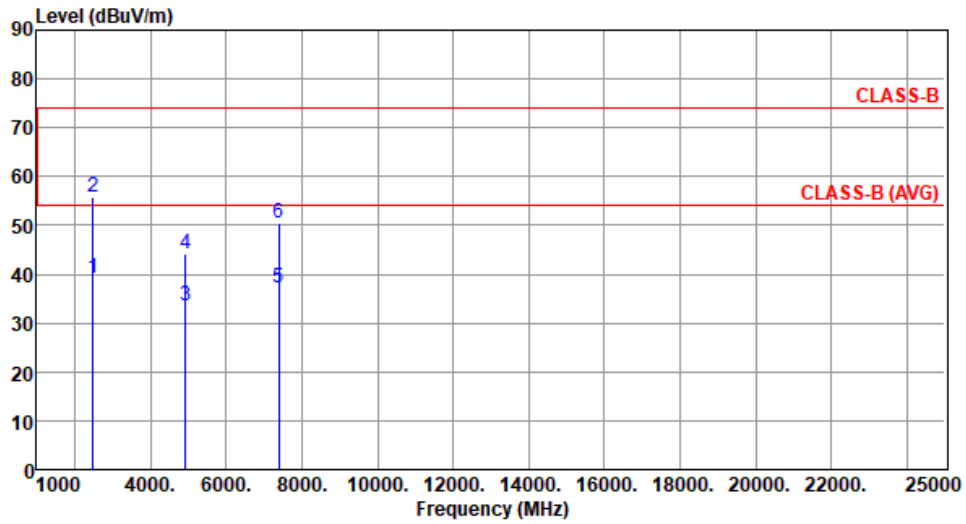

	Freq. MHz	Emission level dBuV/m	Limit dBuV/m	Margin dB	SA reading dBuV	Factor dB/m	Remark	ANT High cm	Turn Table deg
1	2483.50	39.16	54.00	-14.84	43.25	-4.09	Average	111	315
2	2483.50	55.86	74.00	-18.14	59.95	-4.09	Peak	111	315
3	4924.00	33.53	54.00	-20.47	33.45	0.08	Average	318	247
4	4924.00	44.23	74.00	-29.77	44.15	0.08	Peak	318	247
5	7386.00	37.34	54.00	-16.66	31.45	5.89	Average	100	329
6	7386.00	50.59	74.00	-23.41	44.70	5.89	Peak	100	329

Note 1: Emission Level (dBuV/m) = SA Reading (dBuV) + Factor* (dB/m)

*Factor includes antenna factor , cable loss and amplifier gain

Note 2: Margin (dB) = Emission level (dBuV/m) – Limit (dBuV/m).



Modulation	11g	Test Freq. (MHz)	2462
Polarization	Vertical		

Test By :Akun Chung Temperature(°C):25 Humidity(%):65

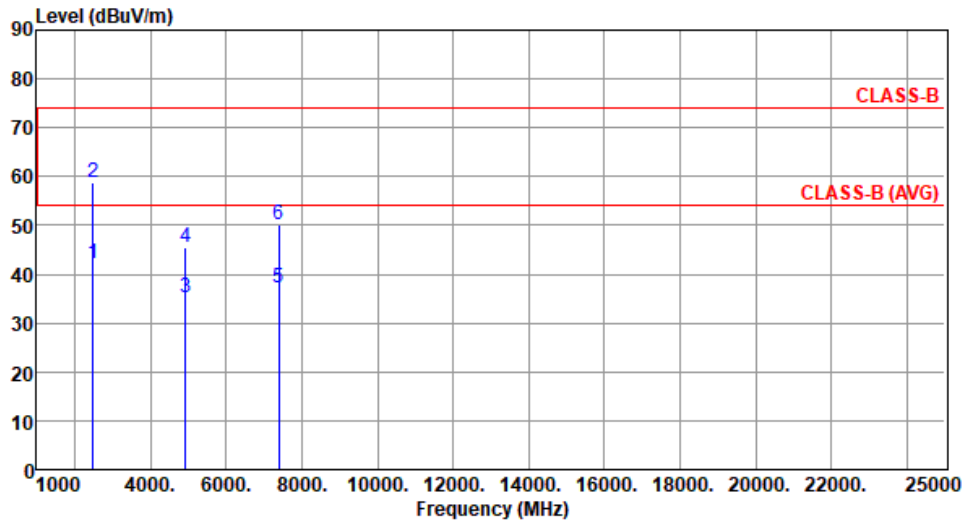

	Freq. MHz	Emission level dBuV/m	Limit dBuV/m	Margin dB	SA reading dBuV	Factor dB/m	Remark	ANT High cm	Turn Table deg
1	2483.50	42.03	54.00	-11.97	46.12	-4.09	Average	312	71
2	2483.50	58.92	74.00	-15.08	63.01	-4.09	Peak	312	71
3	4924.00	35.05	54.00	-18.95	34.97	0.08	Average	304	354
4	4924.00	45.53	74.00	-28.47	45.45	0.08	Peak	304	354
5	7386.00	37.14	54.00	-16.86	31.25	5.89	Average	100	342
6	7386.00	50.14	74.00	-23.86	44.25	5.89	Peak	100	342

Note 1: Emission Level (dBuV/m) = SA Reading (dBuV) + Factor* (dB/m)

*Factor includes antenna factor , cable loss and amplifier gain

Note 2: Margin (dB) = Emission level (dBuV/m) – Limit (dBuV/m).



Unwanted Emissions (Above 1GHz) for HT20

Modulation	HT20	Test Freq. (MHz)	2412
Polarization	Horizontal		

Test By : Akun Chung Temperature(°C): 25 Humidity(%): 65

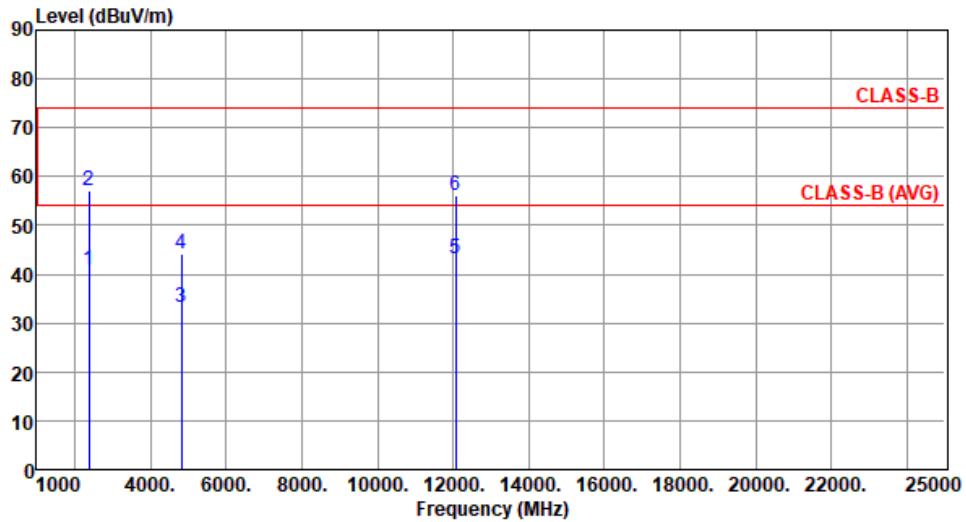

	Freq. MHz	Emission level dBuV/m	Limit dBuV/m	Margin dB	SA reading dBuV	Factor dB/m	Remark	ANT High cm	Turn Table deg
1	2390.00	40.98	54.00	-13.02	44.77	-3.79	Average	115	338
2	2390.00	56.99	74.00	-17.01	60.78	-3.79	Peak	115	338
3	4824.00	33.36	54.00	-20.64	33.24	0.12	Average	320	258
4	4824.00	44.06	74.00	-29.94	43.94	0.12	Peak	320	258
5	12060.00	43.12	54.00	-10.88	35.32	7.80	Average	100	262
6	12060.00	56.07	74.00	-17.93	48.27	7.80	Peak	100	262

Note 1: Emission Level (dBuV/m) = SA Reading (dBuV) + Factor* (dB/m)

*Factor includes antenna factor , cable loss and amplifier gain

Note 2: Margin (dB) = Emission level (dBuV/m) – Limit (dBuV/m).



Modulation	HT20	Test Freq. (MHz)	2412
Polarization	Vertical		

Test By :Akun Chung Temperature(°C):25 Humidity(%):65

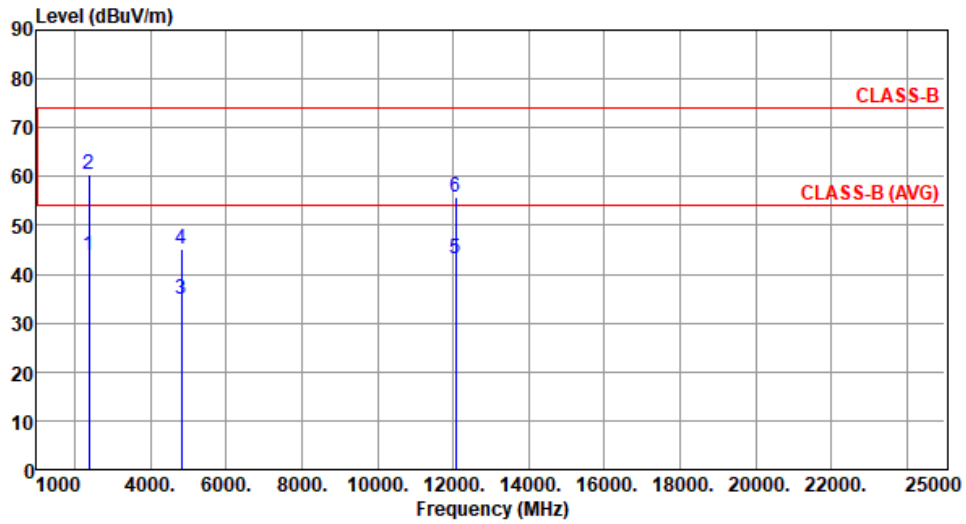

	Freq. MHz	Emission level dBuV/m	Limit dBuV/m	Margin dB	SA reading dBuV	Factor dB/m	Remark	ANT High cm	Turn Table deg
1	2390.00	43.75	54.00	-10.25	47.54	-3.79	Average	317	77
2	2390.00	60.49	74.00	-13.51	64.28	-3.79	Peak	317	77
3	4824.00	34.88	54.00	-19.12	34.76	0.12	Average	300	348
4	4824.00	45.12	74.00	-28.88	45.00	0.12	Peak	300	348
5	12060.00	43.07	54.00	-10.93	35.27	7.80	Average	100	336
6	12060.00	55.95	74.00	-18.05	48.15	7.80	Peak	100	336

Note 1: Emission Level (dBuV/m) = SA Reading (dBuV) + Factor* (dB/m)

*Factor includes antenna factor , cable loss and amplifier gain

Note 2: Margin (dB) = Emission level (dBuV/m) – Limit (dBuV/m).



Modulation	HT20	Test Freq. (MHz)	2437
Polarization	Horizontal		

Test By :Akun Chung Temperature(°C):25 Humidity(%):65

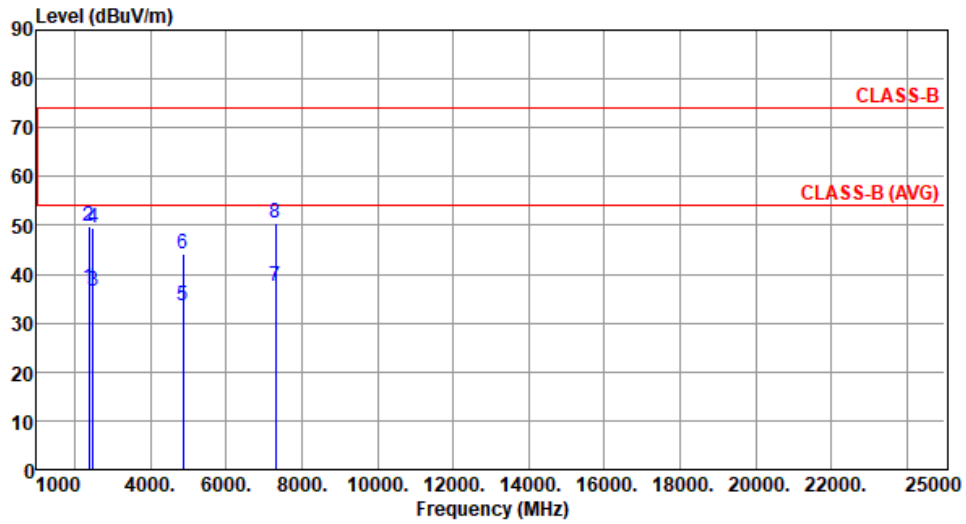

	Freq. MHz	Emission level dBuV/m	Limit dBuV/m	Margin dB	SA reading dBuV	Factor dB/m	Remark	ANT High cm	Turn Table deg
1	2390.00	37.16	54.00	-16.84	40.95	-3.79	Average	113	313
2	2390.00	49.86	74.00	-24.14	53.65	-3.79	Peak	113	313
3	2483.50	36.59	54.00	-17.41	40.68	-4.09	Average	113	313
4	2483.50	49.47	74.00	-24.53	53.56	-4.09	Peak	113	313
5	4874.00	33.63	54.00	-20.37	33.51	0.12	Average	298	247
6	4874.00	44.23	74.00	-29.77	44.11	0.12	Peak	298	247
7	7311.00	37.42	54.00	-16.58	31.48	5.94	Average	100	326
8	7311.00	50.54	74.00	-23.46	44.60	5.94	Peak	100	326

Note 1: Emission Level (dBuV/m) = SA Reading (dBuV) + Factor* (dB/m)

*Factor includes antenna factor , cable loss and amplifier gain

Note 2: Margin (dB) = Emission level (dBuV/m) – Limit (dBuV/m).



Modulation	HT20	Test Freq. (MHz)	2437
Polarization	Vertical		

Test By :Akun Chung Temperature(°C):25 Humidity(%):65

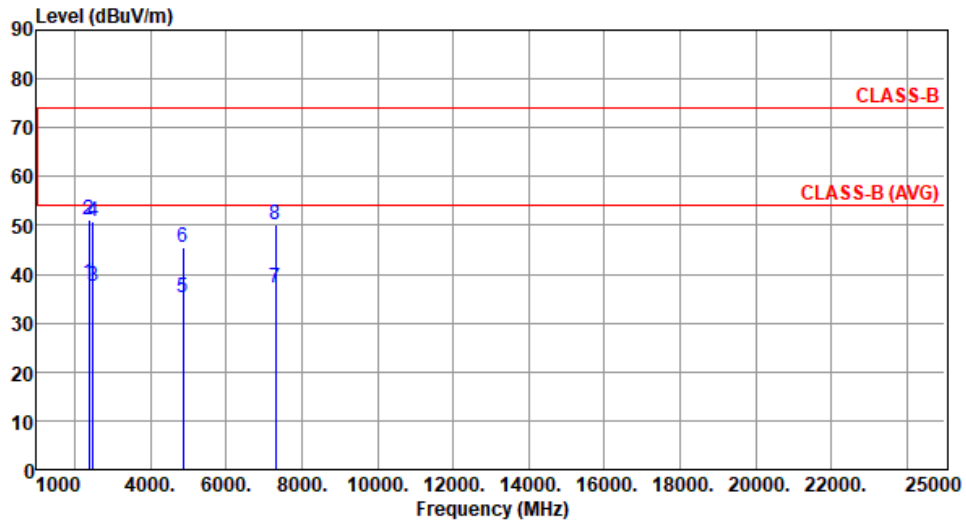

	Freq. MHz	Emission level dBuV/m	Limit dBuV/m	Margin dB	SA reading dBuV	Factor dB/m	Remark	ANT High cm	Turn Table deg
1	2390.00	38.16	54.00	-15.84	41.95	-3.79	Average	302	72
2	2390.00	51.06	74.00	-22.94	54.85	-3.79	Peak	302	72
3	2483.50	37.61	54.00	-16.39	41.70	-4.09	Average	302	72
4	2483.50	50.71	74.00	-23.29	54.80	-4.09	Peak	302	72
5	4874.00	35.08	54.00	-18.92	34.96	0.12	Average	298	357
6	4874.00	45.64	74.00	-28.36	45.52	0.12	Peak	298	357
7	7311.00	37.19	54.00	-16.81	31.25	5.94	Average	100	341
8	7311.00	50.09	74.00	-23.91	44.15	5.94	Peak	100	341

Note 1: Emission Level (dBuV/m) = SA Reading (dBuV) + Factor* (dB/m)

*Factor includes antenna factor , cable loss and amplifier gain

Note 2: Margin (dB) = Emission level (dBuV/m) – Limit (dBuV/m).



Modulation	HT20	Test Freq. (MHz)	2462
Polarization	Horizontal		

Test By : Akun Chung Temperature(°C): 25 Humidity(%): 65

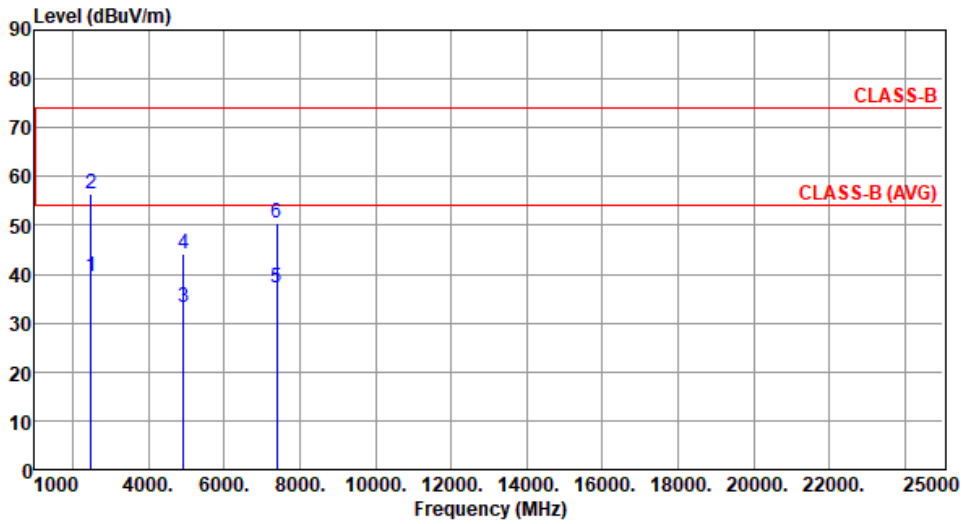

	Freq. MHz	Emission level dBUV/m	Limit dBUV/m	Margin dB	SA reading dBUV	Factor dB/m	Remark	ANT High cm	Turn Table deg
1	2483.50	39.48	54.00	-14.52	43.57	-4.09	Average	113	312
2	2483.50	56.30	74.00	-17.70	60.39	-4.09	Peak	113	312
3	4924.00	33.10	54.00	-20.90	33.02	0.08	Average	328	248
4	4924.00	44.03	74.00	-29.97	43.95	0.08	Peak	328	248
5	7386.00	37.17	54.00	-16.83	31.28	5.89	Average	100	322
6	7386.00	50.34	74.00	-23.66	44.45	5.89	Peak	100	322

Note 1: Emission Level (dBUV/m) = SA Reading (dBUV) + Factor* (dB/m)

*Factor includes antenna factor , cable loss and amplifier gain

Note 2: Margin (dB) = Emission level (dBUV/m) – Limit (dBUV/m).



Modulation	HT20	Test Freq. (MHz)	2462
Polarization	Vertical		

Test By :Akun Chung Temperature(°C):25 Humidity(%):65

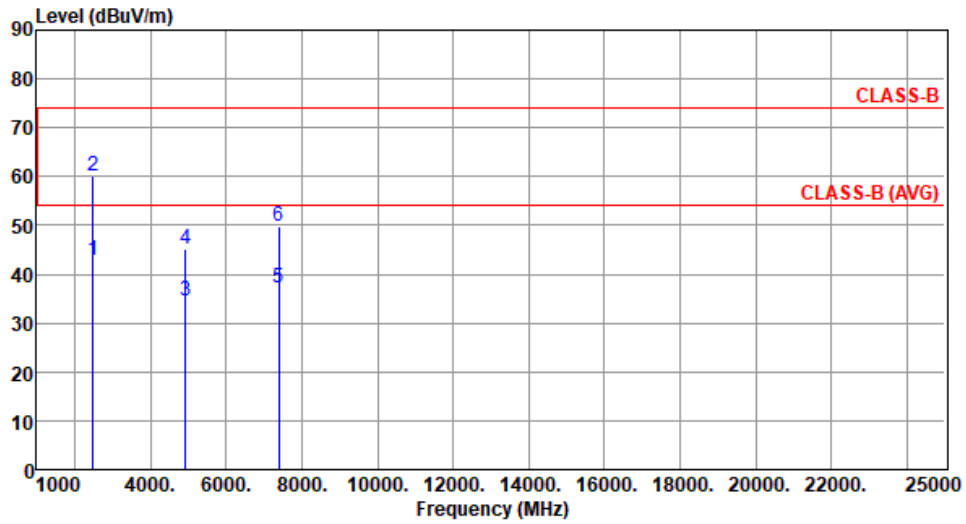

	Freq. MHz	Emission level dBuV/m	Limit dBuV/m	Margin dB	SA reading dBuV	Factor dB/m	Remark	ANT High cm	Turn Table deg
1	2483.50	42.96	54.00	-11.04	47.05	-4.09	Average	304	65
2	2483.50	60.11	74.00	-13.89	64.20	-4.09	Peak	304	65
3	4924.00	34.68	54.00	-19.32	34.60	0.08	Average	309	348
4	4924.00	45.19	74.00	-28.81	45.11	0.08	Peak	309	348
5	7386.00	37.04	54.00	-16.96	31.15	5.89	Average	100	338
6	7386.00	49.84	74.00	-24.16	43.95	5.89	Peak	100	338

Note 1: Emission Level (dBuV/m) = SA Reading (dBuV) + Factor* (dB/m)

*Factor includes antenna factor , cable loss and amplifier gain

Note 2: Margin (dB) = Emission level (dBuV/m) – Limit (dBuV/m).

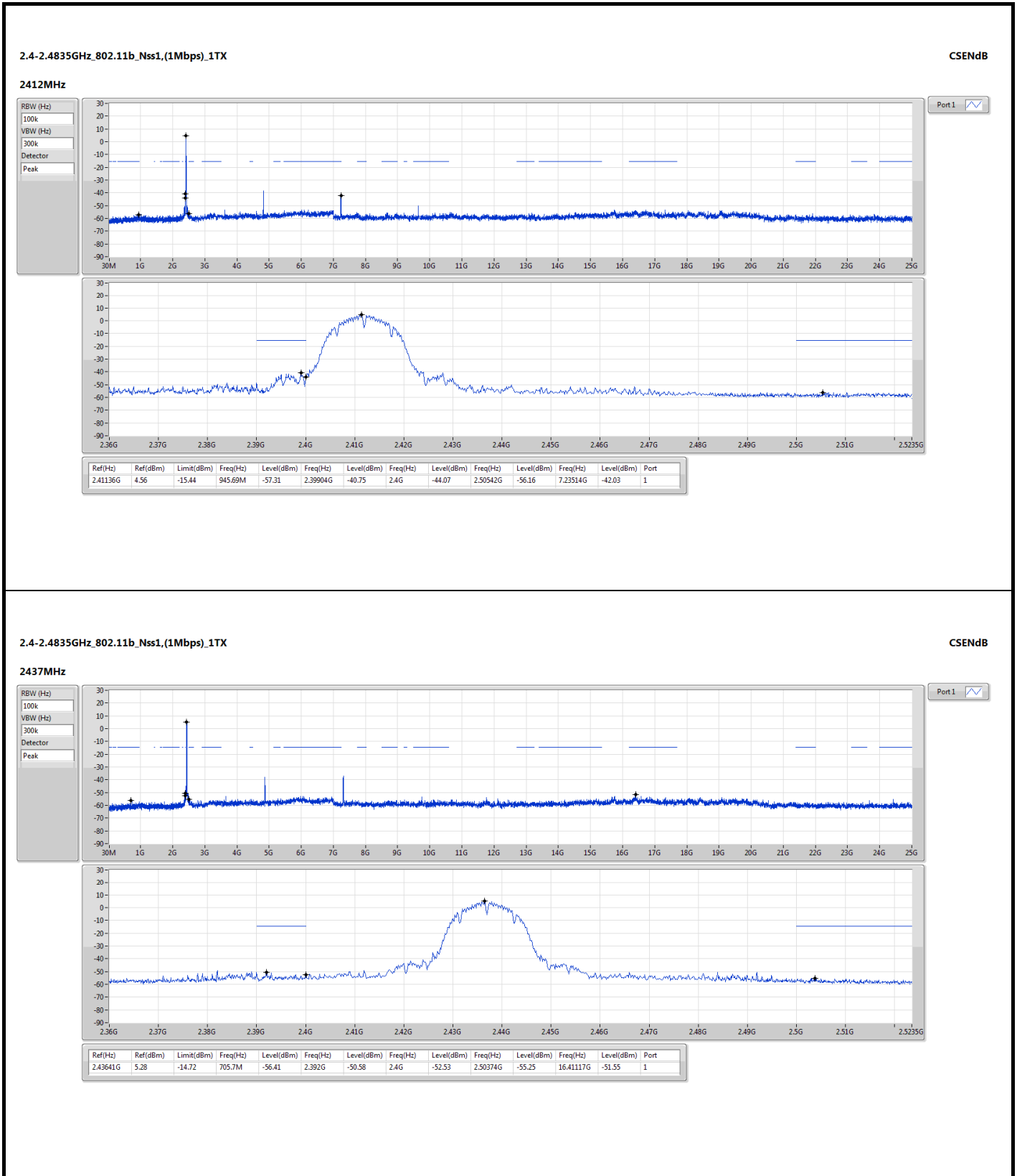

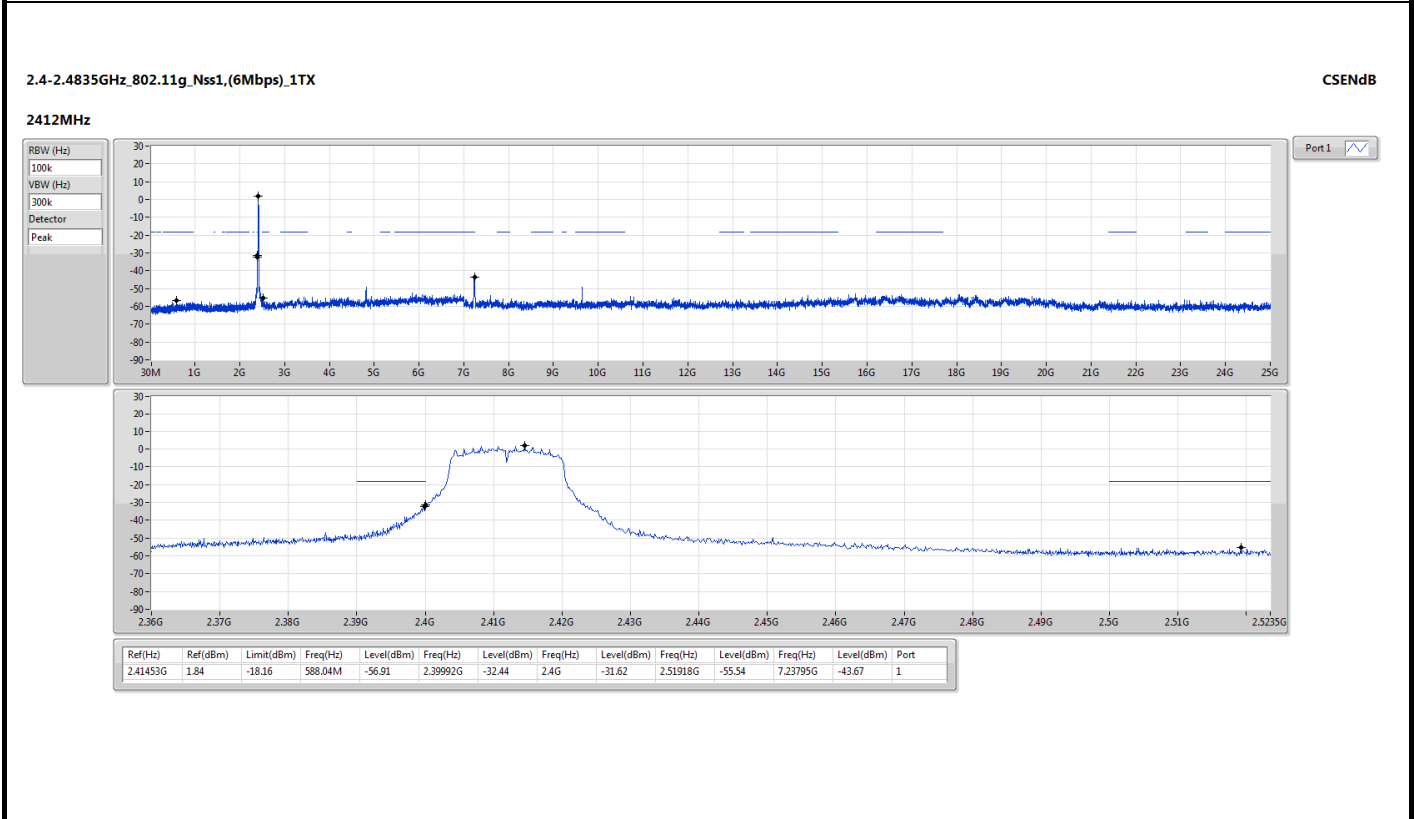
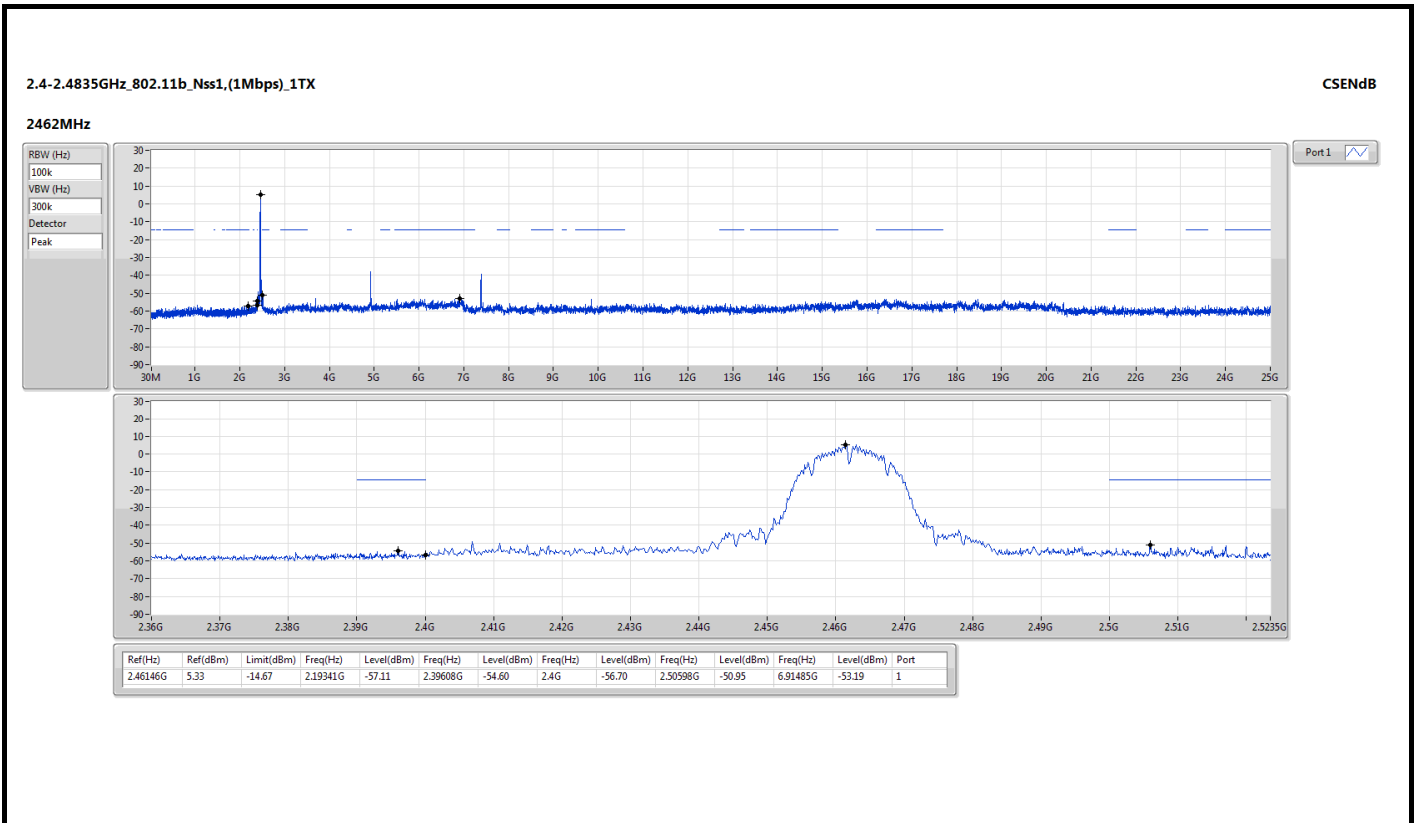

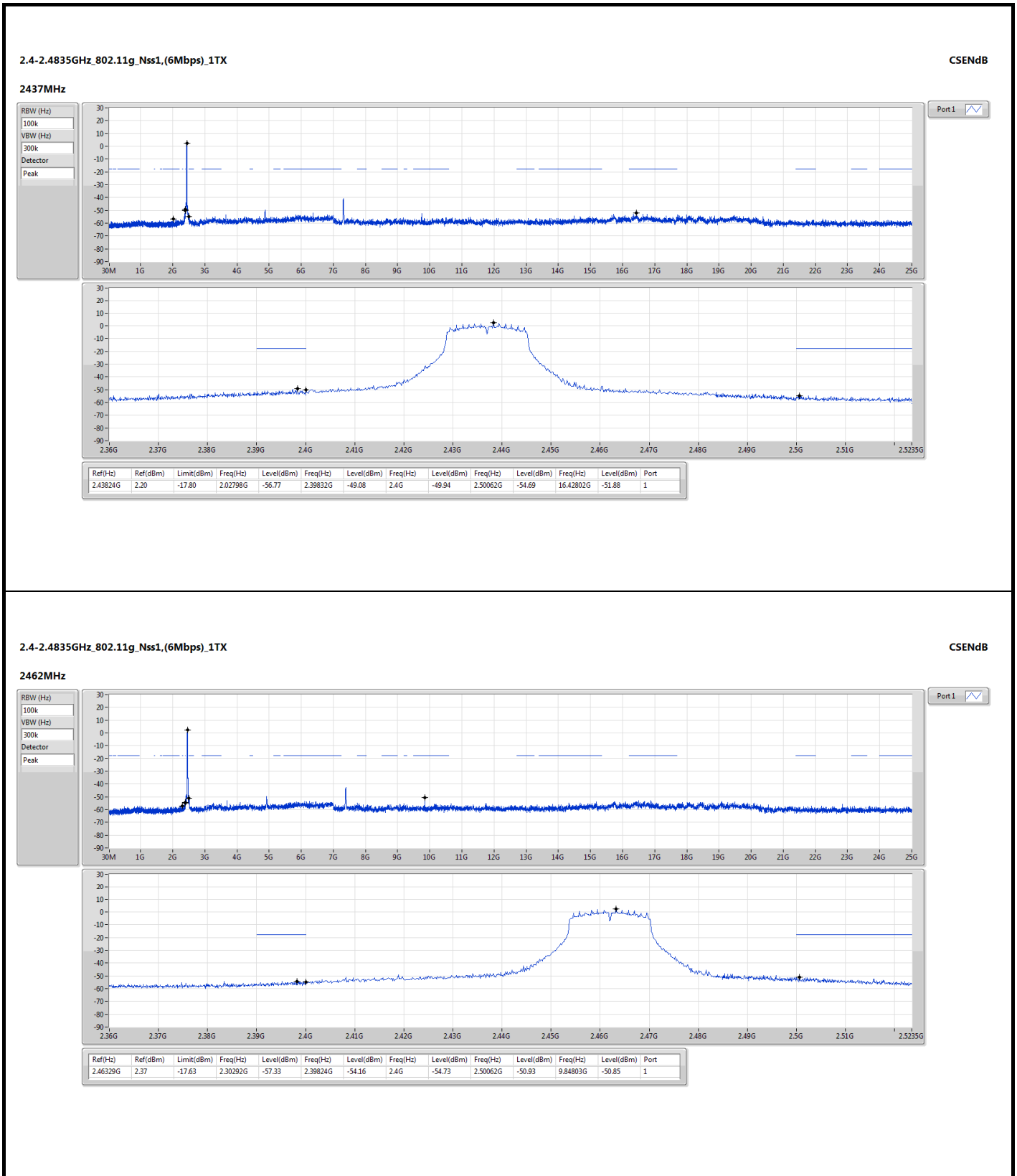

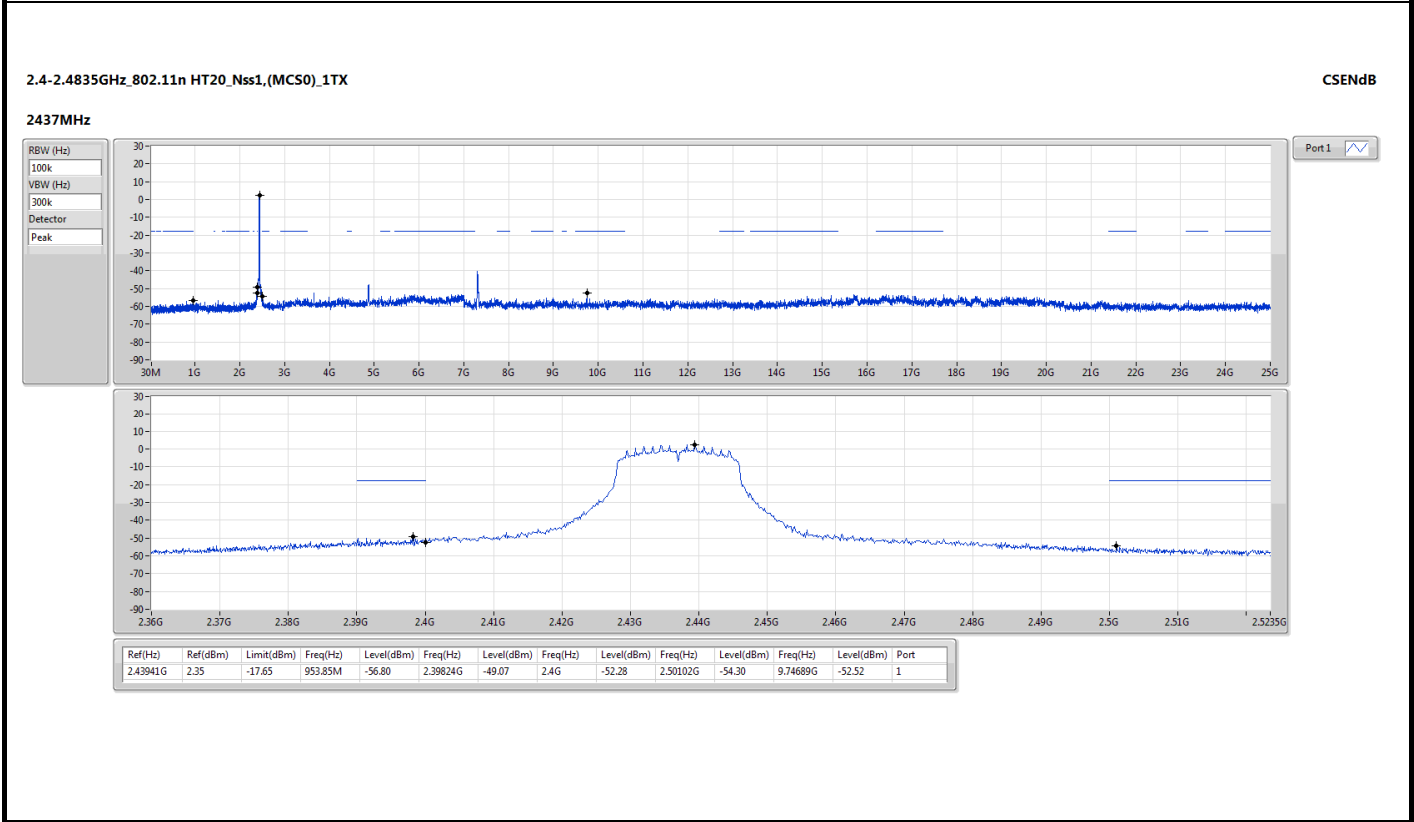
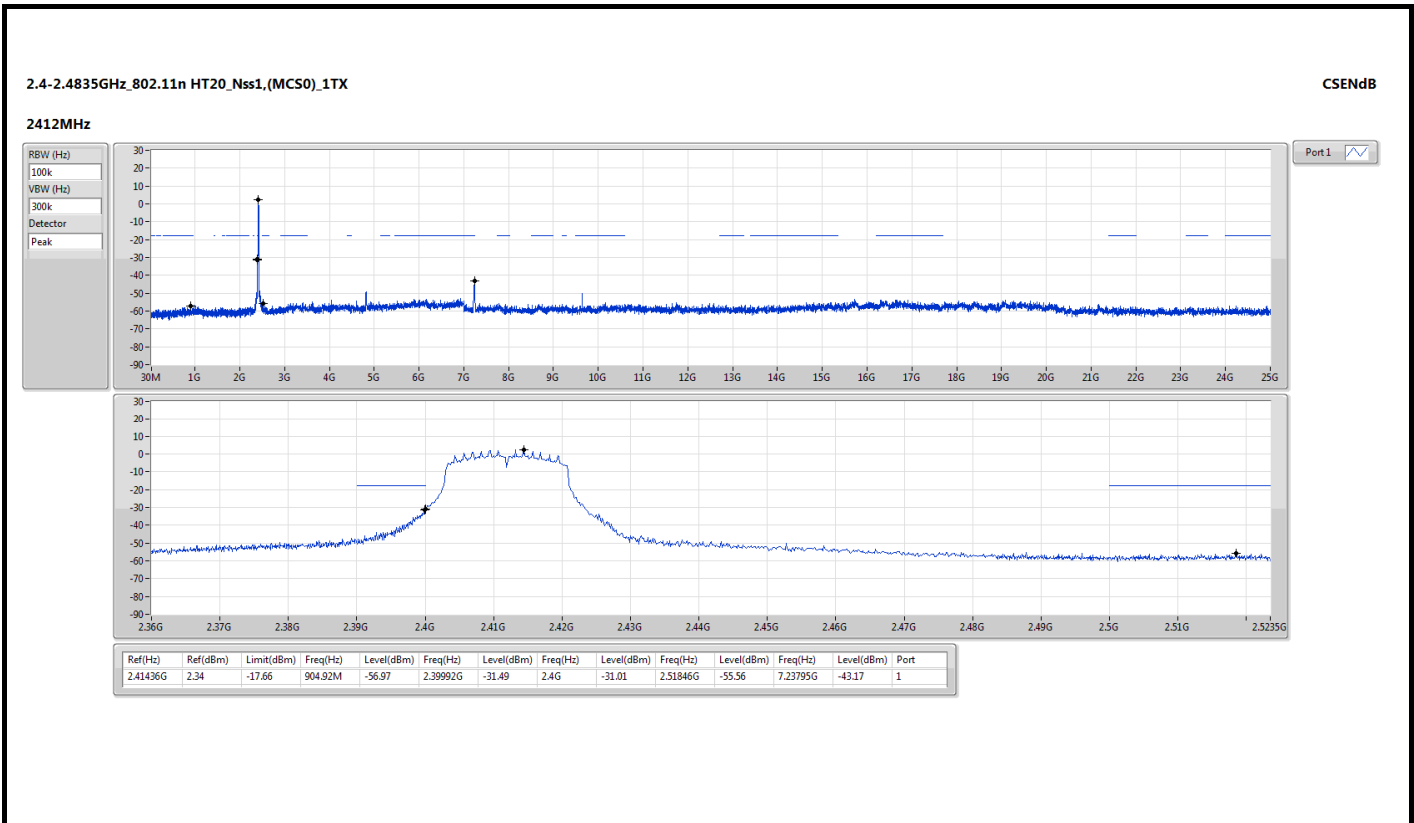

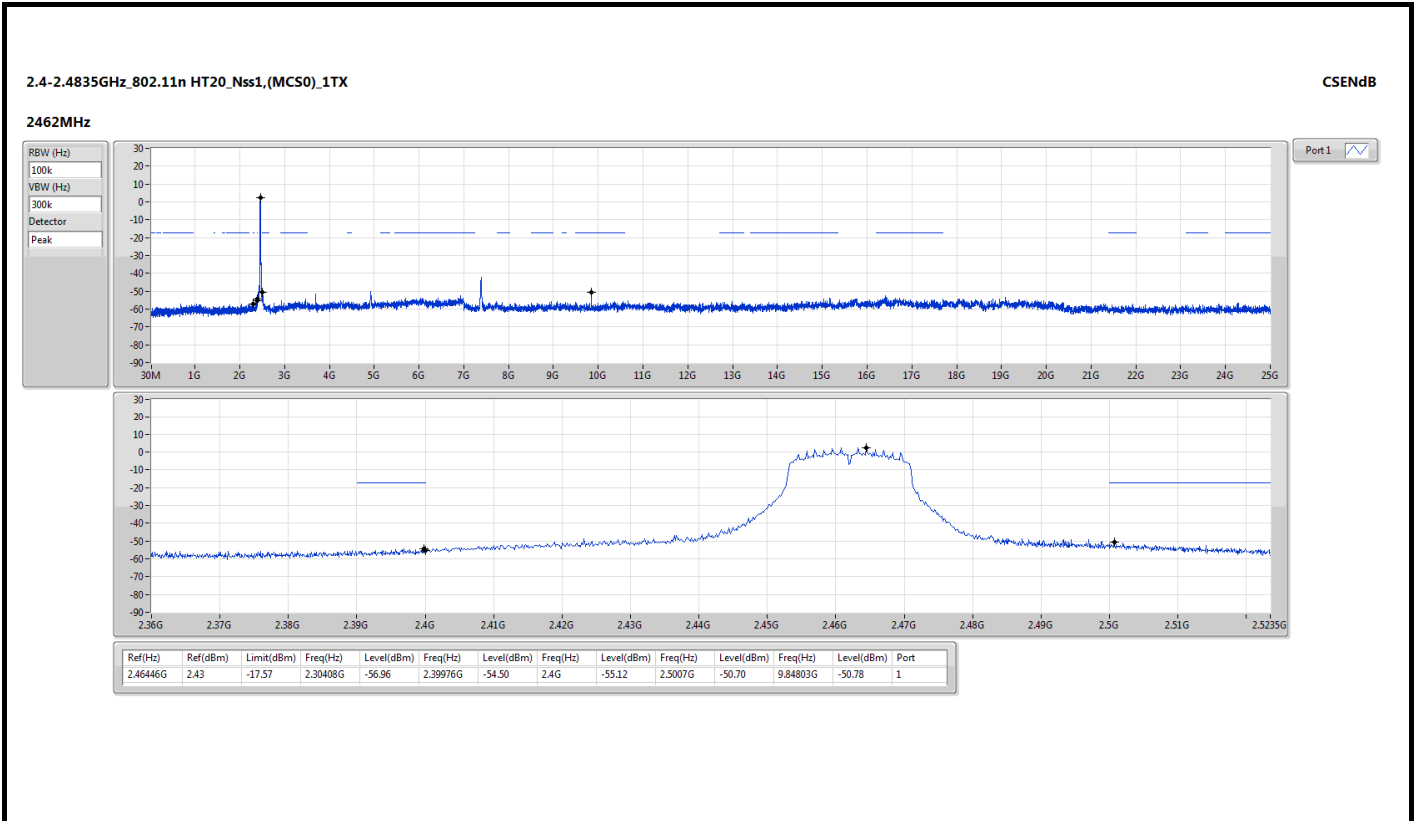



Modulation Mode	11g	Test Freq. (MHz)	2437
Power Phase	Line		

Test by : Joe Liao Temperature: 23°C Humidity: 62%

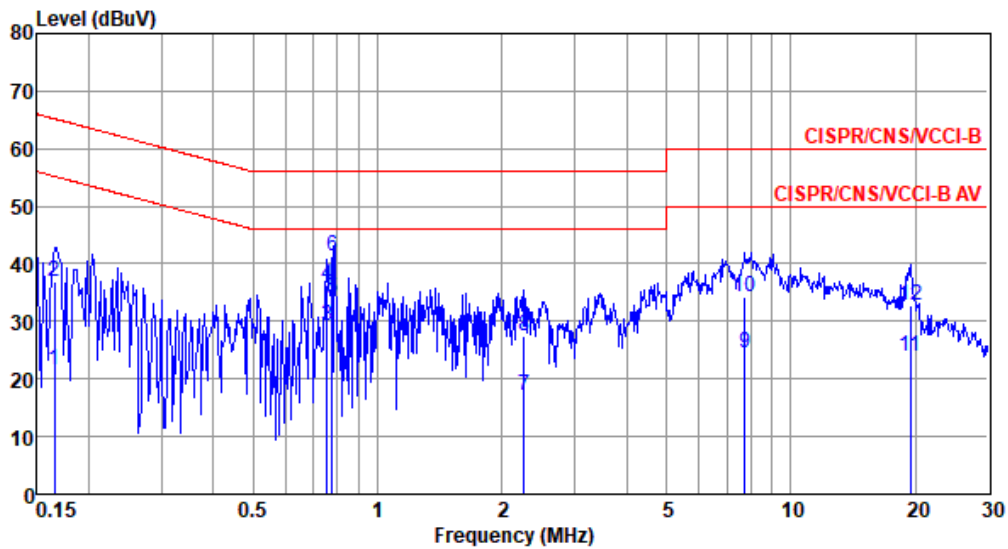

	Freq MHz	Level dBuV	Limit Line dBuV	Over Limit dB	Read Level dBuV	Factor dB	Cable loss dB	Aux dB	Remark
1	0.165	21.42	55.21	-33.79	11.55	9.63	0.06	0.18	Average
2	0.165	36.92	65.21	-28.29	27.05	9.63	0.06	0.18	QP
3	0.755	29.14	46.00	-16.86	19.10	9.63	0.09	0.32	Average
4	0.755	36.21	56.00	-19.79	26.17	9.63	0.09	0.32	QP
5*	0.777	33.83	46.00	-12.17	23.78	9.63	0.10	0.32	Average
6	0.777	41.28	56.00	-14.72	31.23	9.63	0.10	0.32	QP
7	2.261	17.09	46.00	-28.91	6.95	9.63	0.14	0.37	Average
8	2.261	27.59	56.00	-28.41	17.45	9.63	0.14	0.37	QP
9	7.728	24.42	50.00	-25.58	14.00	9.68	0.31	0.43	Average
10	7.728	34.37	60.00	-25.63	23.95	9.68	0.31	0.43	QP
11	19.428	24.02	50.00	-25.98	13.32	9.68	0.50	0.52	Average
12	19.428	32.76	60.00	-27.24	22.06	9.68	0.50	0.52	QP

Note 1: Level (dBuV) = Read Level (dBuV) + LISN Factor (dB) + Cable Loss (dB) + Aux (dB).
 Note 2: Over Limit (dB) = Level (dBuV) - Limit Line (dBuV).



Modulation Mode	11g	Test Freq. (MHz)	2437
Power Phase	Neutral		

Test by : Joe Liao Temperature: 23°C Humidity: 62%

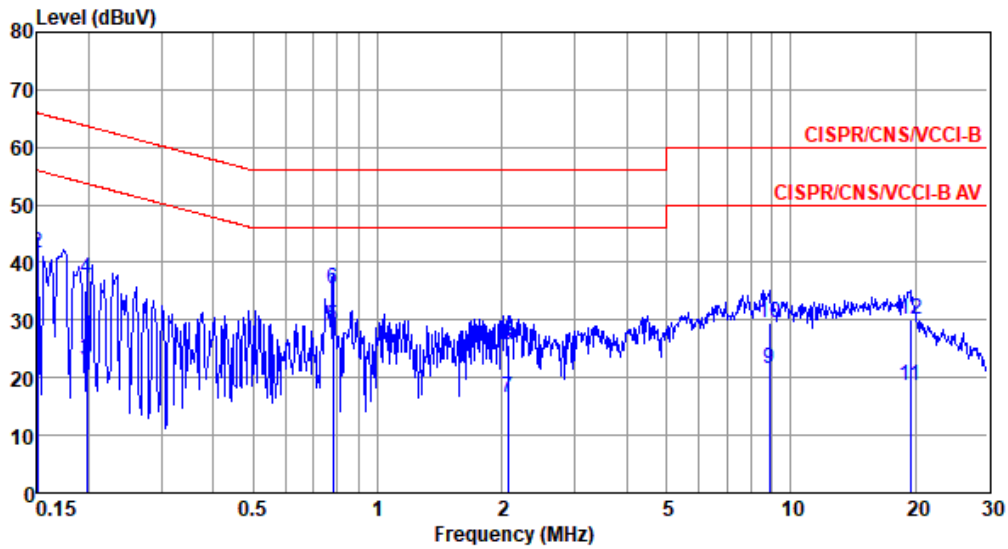

	Freq MHz	Level dBuV	Limit Line dBuV	Over Limit dB	Read Level dBuV	Factor dB	Cable loss dB	Aux dB	Remark
1	0.150	26.37	56.00	-29.63	16.50	9.63	0.06	0.18	Average
2	0.150	41.57	66.00	-24.43	31.70	9.63	0.06	0.18	QP
3	0.198	22.99	53.71	-30.72	13.11	9.63	0.06	0.19	Average
4	0.198	37.21	63.71	-26.50	27.33	9.63	0.06	0.19	QP
5*	0.779	28.79	46.00	-17.21	18.74	9.63	0.10	0.32	Average
6	0.779	35.42	56.00	-20.58	25.37	9.63	0.10	0.32	QP
7	2.066	16.46	46.00	-29.54	6.33	9.64	0.13	0.36	Average
8	2.066	25.73	56.00	-30.27	15.60	9.64	0.13	0.36	QP
9	8.869	21.56	50.00	-28.44	11.08	9.70	0.34	0.44	Average
10	8.869	29.53	60.00	-30.47	19.05	9.70	0.34	0.44	QP
11	19.428	18.45	50.00	-31.55	7.63	9.80	0.50	0.52	Average
12	19.428	30.00	60.00	-30.00	19.18	9.80	0.50	0.52	QP

Note 1: Level (dBuV) = Read Level (dBuV) + LISN Factor (dB) + Cable Loss (dB) + Aux (dB).
 Note 2: Over Limit (dB) = Level (dBuV) - Limit Line (dBuV).