

FCC Test Report

FCC ID : XNAWBS08
Equipment : Withings Body Scan
Model No. : WBS08
Brand Name : Withings
Applicant : Withings
Address : 2 rue Maurice Hartmann
92130 Issy-Les-Moulineaux
France
Standard : 47 CFR FCC Part 15.247
Received Date : Jan. 04, 2023
Tested Date : Jan. 11 ~ Jan. 16, 2023

We, International Certification Corporation, would like to declare that the tested sample has been evaluated and in compliance with the requirement of the above standards. The test results contained in this report refer exclusively to the product. It shall not be reproduced except in full without the written approval of our laboratory.

Reviewed by:

Approved by:

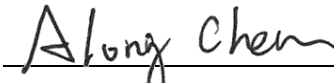

Along Chen / Assistant Manager



Gary Chang / Manager

Table of Contents

1	GENERAL DESCRIPTION	5
1.1	Information.....	5
1.2	Local Support Equipment List	7
1.3	Test Setup Chart	7
1.4	The Equipment List	8
1.5	Test Standards	9
1.6	Reference Guidance	9
1.7	Deviation from Test Standard and Measurement Procedure.....	9
1.8	Measurement Uncertainty	9
2	TEST CONFIGURATION.....	10
2.1	Testing Facility	10
2.2	The Worst Test Modes and Channel Details	10
3	TRANSMITTER TEST RESULTS	11
3.1	6dB and Occupied Bandwidth	11
3.2	Conducted Output Power	12
3.3	Power Spectral Density	13
3.4	Unwanted Emissions into Restricted Frequency Bands	14
3.5	Emissions in Non-Restricted Frequency Bands.....	16
3.6	AC Power Line Conducted Emissions	17
4	TEST LABORATORY INFORMATION	18
Appendix A. 6dB and Occupied Bandwidth		
Appendix B. Conducted Output Power		
Appendix C. Power Spectral Density		
Appendix D. Unwanted Emissions into Restricted Frequency Bands		
Appendix E. Emissions in Non-Restricted Frequency Bands		
Appendix F. AC Power Line Conducted Emissions		

Release Record

Report No.	Version	Description	Issued Date
FR261601-04AC	Rev. 01	Initial issue	Mar. 07, 2023

Summary of Test Results

FCC Rules	Test Items	Measured	Result
15.207	AC Power Line Conducted Emission	[dBuV]: 0.150MHz 49.61(Margin -16.39dB) - QP	Pass
15.247(d) 15.209	Unwanted Emissions	[dBuV/m at 3m]: 41.64MHz 35.56 (Margin -4.44dB) - PK	Pass
15.247(b)(3)	Conducted Output Power	Max Power [dBm]: 22.96	Pass
15.247(a)(2)	6dB Bandwidth	Meet the requirement of limit	Pass
15.247(e)	Power Spectral Density	Meet the requirement of limit	Pass
15.203	Antenna Requirement	Meet the requirement of limit	Pass

Declaration of Conformity:

The test results with all measurement uncertainty excluded are presented in accordance with the regulation limits or requirements declared by manufacturers.

Comments and Explanations:

The declared of product specification for EUT presented in the report are provided by the manufacturer, and the manufacturer takes all the responsibilities for the accuracy of product specification.

1 General Description

1.1 Information

1.1.1 Specification of the Equipment under Test (EUT)

RF General Information					
Frequency Range (MHz)	IEEE Std. 802.11	Ch. Freq. (MHz)	Channel Number	Transmit Chains (N _{TX})	Data Rate / MCS
2400-2483.5	b	2412-2462	1-11 [11]	1	1-11 Mbps
2400-2483.5	g	2412-2462	1-11 [11]	1	6-54 Mbps
2400-2483.5	n (HT20)	2412-2462	1-11 [11]	1	MCS 0-7

Note 1: RF output power specifies that Maximum Conducted (Average) Output Power.
 Note 2: DSSS-DBPSK, DQPSK, CCK modulation
 OFDM - BPSK, QPSK, 16QAM, 64QAM modulation.

1.1.2 Antenna Details

Ant. No.	Brand	Model	Type	Connector	Gain (dBi)
1	BROADCOM	BCM9Fractal64	PCB	N/A	2.8

1.1.3 Power Supply Type of Equipment under Test (EUT)

Power Supply Type	3.7Vdc from AC adapter
--------------------------	------------------------

Note: The above power supply is not bundled in market.

1.1.4 Accessories

Accessories		
No.	Equipment	Description
1	Cable stopper	---
2	Wall handle support	---
3	USB-C Cable	0.75m non-shielded without core

1.1.5 Test Sample Information

MAC of Test Sample	Radiated: 00:24:E4:FF:70:A2 AC Power line conducted emission: 00:24:E4:FF:70:A2 Conducted: A4:7E:FA:0D:CB:EA
---------------------------	--

1.1.6 Channel List

Channel	Frequency(MHz)
1	2412
2	2417
3	2422
4	2427
5	2432
6	2437
7	2442
8	2447
9	2452
10	2457
11	2462

1.1.7 Test Tool and Duty Cycle

Test Tool	Tera Term, Version: 4.74		
Duty Cycle and Duty Factor	Mode	Duty Cycle (%)	Duty Factor (dB)
	11b	99.49%	0.02
	11g	94.20%	0.26
	HT20	93.81%	0.28

1.1.8 Power Index of Test Tool

Modulation Mode	Test Frequency (MHz)	Power Index
11b	2412	16
11b	2437	16
11b	2462	16
11g	2412	15.5
11g	2437	15.5
11g	2462	15.5
HT20	2412	15.5
HT20	2437	15.5
HT20	2462	15.5

1.2 Local Support Equipment List

Support Equipment List					
No.	Equipment	Brand	Model	FCC ID	Remarks
1	Adapter	Samsung	ETA-U90JWS	---	---

Note: The support notebook and fixture are disconnected from EUT and removed from test table after sending command to EUT to control EUT to transmit continuously.

1.3 Test Setup Chart

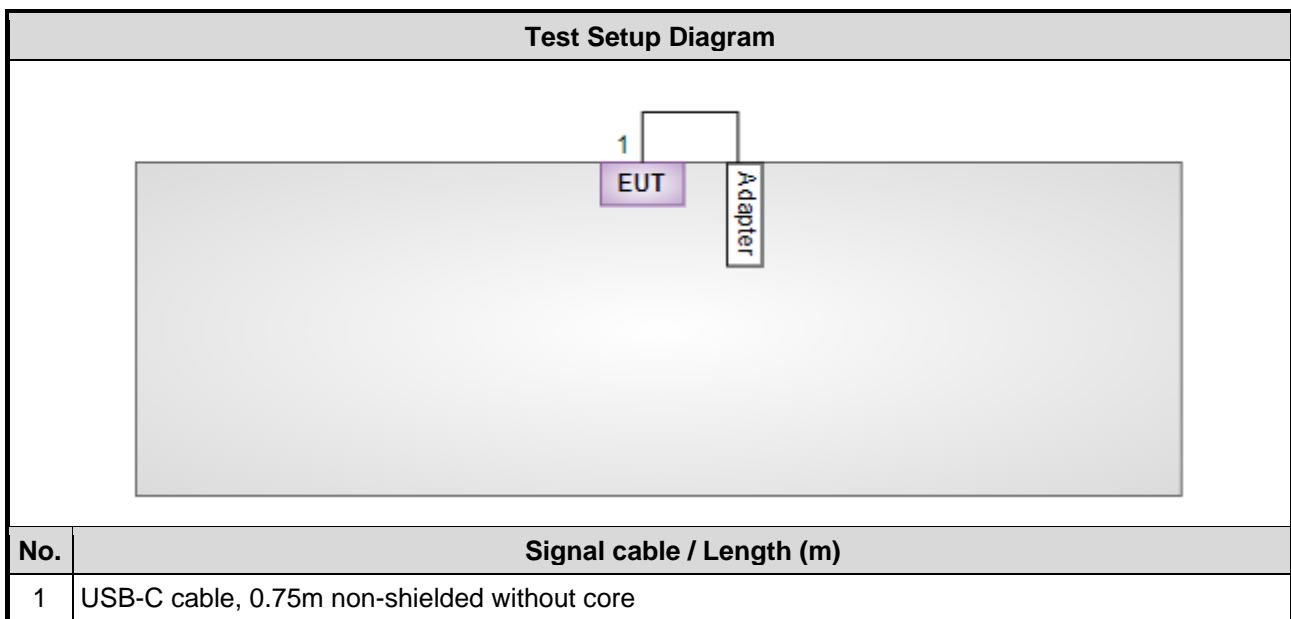

1.4 The Equipment List

Test Item	Conducted Emission				
Test Site	Conduction room 1 / (CO01-WS)				
Tested Date	Jan. 16, 2023				
Instrument	Brand	Model No.	Serial No.	Calibration Date	Calibration Until
Receiver	R&S	ESR3	101658	Feb. 16, 2022	Feb. 15, 2023
LISN	R&S	ENV216	101579	Apr. 21, 2022	Apr. 20, 2023
LISN (Support Unit)	SCHWARZBECK	Schwarzbeck 8127	8127666	Feb. 15, 2022	Feb. 14, 2023
RF Cable-CON	Woken	CFD200-NL	CFD200-NL-001	Oct. 17, 2022	Oct. 16, 2023
50 ohm terminal (Support Unit)	NA	50	01	May 10, 2022	May 09, 2023
Measurement Software	AUDIX	e3	6.120210k	NA	NA

Note: Calibration Interval of instruments listed above is one year.

Test Item	Radiated Emission				
Test Site	966 chamber1 / (03CH01-WS)				
Tested Date	Jan. 11 ~ Jan. 16, 2023				
Instrument	Brand	Model No.	Serial No.	Calibration Date	Calibration Until
Receiver	R&S	ESR3	101657	Mar. 15, 2022	Mar. 14, 2023
Spectrum Analyzer	R&S	FSV40	101498	Nov. 21, 2022	Nov. 20, 2023
Loop Antenna	R&S	HFH2-Z2	100330	Nov. 01, 2022	Oct. 31, 2023
Bilog Antenna	SCHWARZBECK	VULB9168	VULB9168-522	Aug. 03, 2022	Aug. 02, 2023
Horn Antenna 1G-18G	SCHWARZBECK	BBHA 9120 D	BBHA 9120 D 1096	Nov. 25, 2022	Nov. 24, 2023
Horn Antenna 18G-40G	SCHWARZBECK	BBHA 9170	BBHA 9170517	Oct. 27, 2022	Oct. 26, 2023
Preamplifier	EMC	EMC02325	980225	Jun. 28, 2022	Jun. 27, 2023
Preamplifier	EMC	EMC118A45SE	980898	Jul. 16, 2022	Jul. 15, 2023
Preamplifier	EMC	EMC184045SE	980903	Jul. 16, 2022	Jul. 15, 2023
Loop Antenna Cable	KOAX KABEL	101354-BW	101354-BW	Oct. 04, 2022	Oct. 03, 2023
LF cable 3M	Woken	CFD400NL-LW	CFD400NL-001	Oct. 04, 2022	Oct. 03, 2023
LF cable 11M	EMC	EMCCFD400-NW-N W-11000	200801	Oct. 04, 2022	Oct. 03, 2023
LF cable 1M	EMC	EMCCFD400-NM-N M-1000	160502	Oct. 04, 2022	Oct. 03, 2023
RF Cable	EMC	EMC104-35M-35M- 8000	210920	Oct. 04, 2022	Oct. 03, 2023
RF Cable	EMC	EMC104-35M-35M- 3000	210922	Oct. 04, 2022	Oct. 03, 2023
Measurement Software	AUDIX	e3	6.120210g	NA	NA

Note: Calibration Interval of instruments listed above is one year.

Test Item	RF Conducted				
Test Site	(TH01-WS)				
Tested Date	Jan. 16, 2023				
Instrument	Brand	Model No.	Serial No.	Calibration Date	Calibration Until
Spectrum Analyzer	R&S	FSV40	101910	Apr. 08, 2022	Apr. 07, 2023
Power Meter	Anritsu	ML2495A	1241002	Nov. 23, 2022	Nov. 22, 2023
Power Sensor	Anritsu	MA2411B	1207366	Nov. 23, 2022	Nov. 22, 2023
Measurement Software	Sporton	SENSE-15247_FS	V5.10.8.9	NA	NA
Note: Calibration Interval of instruments listed above is one year.					

1.5 Test Standards

47 CFR FCC Part 15.247
ANSI C63.10-2013

1.6 Reference Guidance

FCC KDB 558074 D01 15.247 Meas Guidance v05r02

1.7 Deviation from Test Standard and Measurement Procedure

None

1.8 Measurement Uncertainty

The measurement uncertainties given below are based on a 95% confidence level (based on a coverage factor ($k=2$)).

Measurement Uncertainty	
Parameters	Uncertainty
Bandwidth	± 34.130 Hz
Conducted power	± 0.808 dB
Power density	± 0.583 dB
Conducted emission	± 2.715 dB
AC conducted emission	± 2.92 dB
Unwanted Emission ≤ 1 GHz	± 3.41 dB
Unwanted Emission > 1 GHz	± 4.9 dB

2 Test Configuration

2.1 Testing Facility

Test Laboratory	International Certification Corporation
Test Site	CO01-WS, 03CH01-WS, TH01-WS
Address of Test Site	No.3-1, Lane 6, Wen San 3rd St., Kwei Shan Dist., Tao Yuan City 33381, Taiwan (R.O.C.)

- FCC Designation No.: TW2732
- FCC site registration No.: 181692
- ISED#: 10807A
- CAB identifier: TW2732

2.2 The Worst Test Modes and Channel Details

Test item	Modulation Mode	Test Frequency (MHz)	Data Rate	Test Configuration
AC Power Line Conducted Emission	11g	2462	6 Mbps	---
Unwanted Emissions ≤ 1GHz	11g	2462	6 Mbps	---
Unwanted Emissions >1GHz				
Conducted Output Power	11b	2412 / 2437 / 2462	1 Mbps	---
6dB bandwidth	11g	2412 / 2437 / 2462	6 Mbps	
Power spectral density	HT20	2412 / 2437 / 2462	MCS 0	

3 Transmitter Test Results

3.1 6dB and Occupied Bandwidth

3.1.1 Limit of 6dB Bandwidth

The minimum 6dB bandwidth shall be at least 500 kHz.

3.1.2 Test Procedures

6dB Bandwidth

1. Set resolution bandwidth (RBW) = 100 kHz, Video bandwidth = 300 kHz.
2. Detector = Peak, Trace mode = max hold.
3. Sweep = auto couple, Allow the trace to stabilize.
4. Measure the maximum width of the emission that is constrained by the frequencies associated with the two outermost amplitude points (upper and lower) that are attenuated by 6dB relative to the maximum level measured in the fundamental emission.

Occupied Bandwidth

1. Set resolution bandwidth (RBW) = 1% ~ 5 % of OBW, Video bandwidth = 3 x RBW
2. Detector = Sample, Trace mode = max hold.
3. Sweep = auto couple, Allow the trace to stabilize.
4. Use the OBW measurement function of spectrum analyzer to measure the occupied bandwidth.

3.1.3 Test Setup

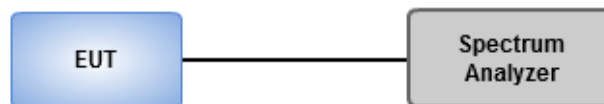

3.1.4 Test Results

Ambient Condition	23°C / 65%	Tested By	Roger Lu
--------------------------	------------	------------------	----------

Refer to Appendix A.

3.2 Conducted Output Power

3.2.1 Limit of Conducted Output Power

Conducted power shall not exceed 1Watt.

Antenna gain $\leq 6\text{dBi}$, no any corresponding reduction is in output power limit.

Antenna gain $> 6\text{dBi}$

Non Fixed, point to point operations.

The conducted output power from the intentional radiator shall be reduced by the amount in dB that the directional gain of the antenna exceeds 6 dB

Fixed, point to point operations

Systems operating in the 2400–2483.5 MHz band that are used exclusively for fixed, point-to-point Operations, maximum peak output power of the intentional radiator is reduced by 1 dB for every 3 dB that the directional gain of the antenna exceeds 6 dBi.

3.2.2 Test Procedures

A broadband RF power meter is used for output power measurement. The video bandwidth of power meter is greater than DTS bandwidth of EUT. If duty cycle of test signal is not 100 %, trigger and gating function of power meter will be enabled to capture transmission burst for measuring output power.

3.2.3 Test Setup

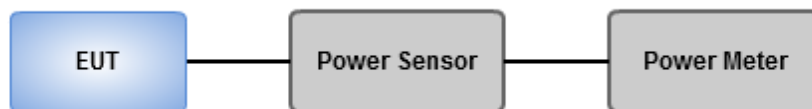

3.2.4 Test Results

Ambient Condition	23°C / 65%	Tested By	Roger Lu
--------------------------	------------	------------------	----------

Refer to Appendix B.

3.3 Power Spectral Density

3.3.1 Limit of Power Spectral Density

Power spectral density shall not be greater than 8 dBm in any 3 kHz band.

3.3.2 Test Procedures

Peak PSD

1. Set the RBW = 3 kHz, VBW = 10 kHz.
2. Detector = Peak, Sweep time = auto couple.
3. Trace mode = max hold, allow trace to fully stabilize.
4. Use the peak marker function to determine the maximum amplitude level.

Average PSD, duty cycle \geq 98%

1. Set the RBW = 30 kHz, VBW = 100 kHz.
2. Detector = RMS, Sweep time = auto couple.
3. Sweep time = auto couple.
4. Employ trace averaging (RMS) mode over a minimum of 100 traces.
5. Use the peak marker function to determine the maximum amplitude level.

Average PSD, duty cycle $<$ 98%

1. Set the RBW = 30 kHz, VBW = 100 kHz. Detector = RMS.
2. Set the sweep time to: ≥ 10 (number of measurement points in sweep) x (total on/off period of the transmitted signal).
3. Perform the measurement over a single sweep.
4. Use the peak marker function to determine the maximum amplitude level.
5. Add $10 \log (1/x)$, where x is the duty cycle.

3.3.3 Test Setup

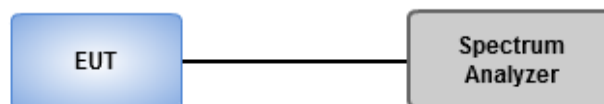

3.3.4 Test Results

Ambient Condition	23°C / 65%	Tested By	Roger Lu
--------------------------	------------	------------------	----------

Refer to Appendix C.

3.4 Unwanted Emissions into Restricted Frequency Bands

3.4.1 Limit of Unwanted Emissions into Restricted Frequency Bands

Restricted Band Emissions Limit			
Frequency Range (MHz)	Field Strength (uV/m)	Field Strength (dBuV/m)	Measure Distance (m)
0.009~0.490	2400/F(kHz)	48.5 - 13.8	300
0.490~1.705	24000/F(kHz)	33.8 - 23	30
1.705~30.0	30	29	30
30~88	100	40	3
88~216	150	43.5	3
216~960	200	46	3
Above 960	500	54	3

Note 1:
Qusai-Peak value is measured for frequency below 1GHz except for 9–90 kHz, 110–490 kHz frequency band. Peak and average value are measured for frequency above 1GHz. The limit on average radio frequency emission is as above table. The limit on peak radio frequency emissions is 20 dB above the maximum permitted average emission limit

Note 2:
Measurements may be performed at a distance other than what is specified provided. When performing measurements at a distance other than that specified, the results shall be extrapolated to the specified distance using an extrapolation factor as below, Frequency at or above 30 MHz: 20 dB/decade Frequency below 30 MHz: 40 dB/decade.

3.4.2 Test Procedures

1. Measurement is made at a semi-anechoic chamber that incorporates a turntable allowing a EUT rotation of 360°. A continuously-rotating, remotely-controlled turntable is installed at the test site to support the EUT and facilitate determination of the direction of maximum radiation for each EUT emission frequency. The EUT is placed at test table. For emissions testing at or below 1 GHz, the table height is 80 cm above the reference ground plane. For emission measurements above 1 GHz, the table height is 1.5 m
2. Measurement is made with the antenna positioned in both the horizontal and vertical planes of polarization. The measurement antenna is varied in height (1m ~ 4m) above the reference ground plane to obtain the maximum signal strength. Distance between EUT and antenna is 3 m.
3. This investigation is performed with the EUT rotated 360°, the antenna height scanned between 1 m and 4 m, and the antenna rotated to repeat the measurements for both the horizontal and vertical antenna polarizations.

Note:

1. 120kHz measurement bandwidth of test receiver and Quasi-peak detector is for radiated emission below 1GHz.
2. RBW=1MHz, VBW=3MHz and Peak detector is for peak measured value of radiated emission above 1GHz.
3. RBW=1MHz, VBW=1/T and Peak detector is for average measured value of radiated emission above 1GHz.

3.4.3 Test Setup

Radiated Emissions below 1 GHz

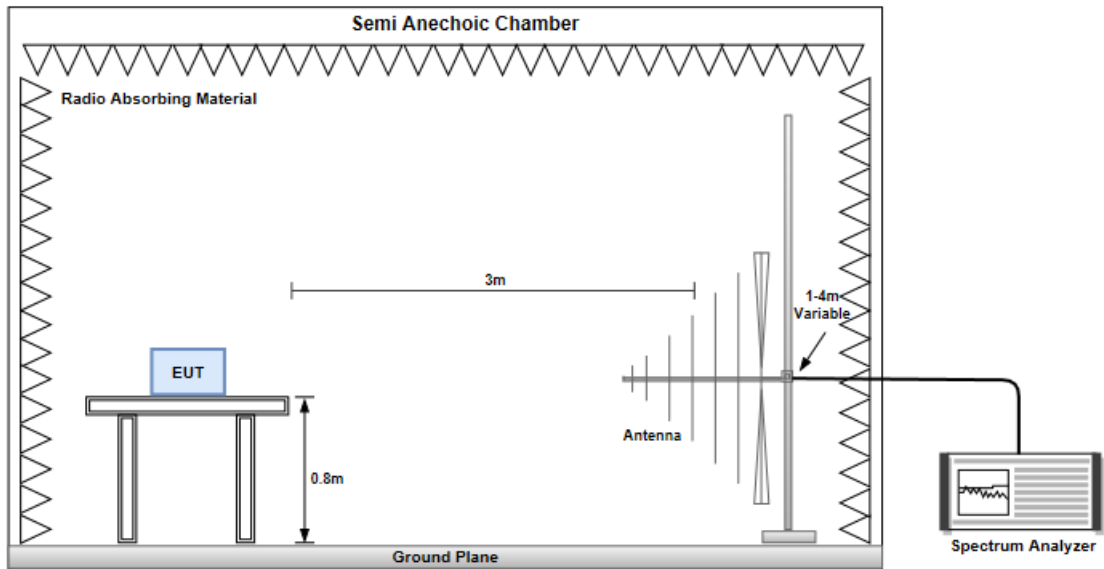

Radiated Emissions above 1 GHz

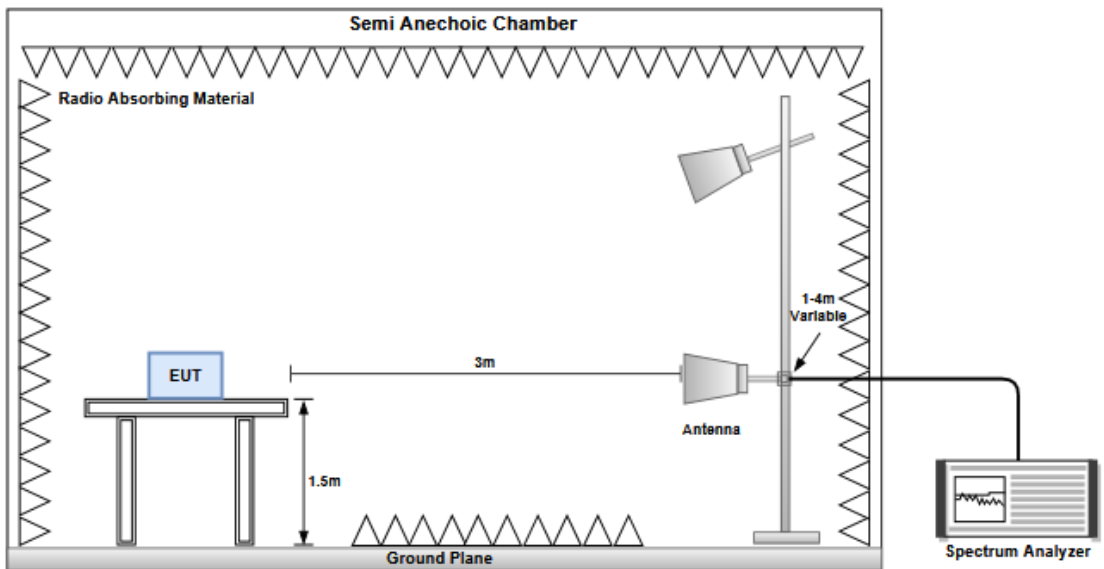

3.4.4 Test Results

Refer to Appendix D.

3.5 Emissions in Non-Restricted Frequency Bands

3.5.1 Emissions in Non-Restricted Frequency Bands Limit

Peak power in any 100 kHz bandwidth outside of the authorized frequency band shall be attenuated by at least 20 dB relative to the maximum in-band peak PSD level in 100 kHz.

3.5.2 Test Procedures

Reference level measurement

1. Set RBW=100kHz, VBW = 300kHz , Detector = Peak, Sweep time = Auto
2. Trace = max hold , Allow Trace to fully stabilize
3. Use the peak marker function to determine the maximum PSD level

Emission level measurement

1. Set RBW=100kHz, VBW = 300kHz , Detector = Peak, Sweep time = Auto
2. Trace = max hold , Allow Trace to fully stabilize
3. Scan Frequency range is up to 25GHz
4. Use the peak marker function to determine the maximum amplitude level

3.5.3 Test Setup

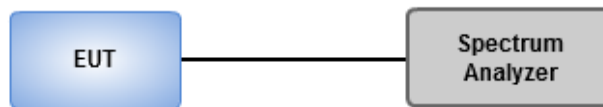

3.5.4 Test Results

Ambient Condition	23°C / 65%	Tested By	Roger Lu
--------------------------	------------	------------------	----------

Refer to Appendix E.

3.6 AC Power Line Conducted Emissions

3.6.1 Limit of AC Power Line Conducted Emissions

Conducted Emissions Limit		
Frequency Emission (MHz)	Quasi-Peak	Average
0.15-0.5	66 - 56 *	56 - 46 *
0.5-5	56	46
5-30	60	50

Note 1: * Decreases with the logarithm of the frequency.

3.6.2 Test Procedures

1. The device is placed on a test table, raised 80 cm above the reference ground plane. The vertical conducting plane is located 40 cm to the rear of the device.
2. The device is connected to line impedance stabilization network (LISN) and other accessories are connected to other LISN. Measured levels of AC power line conducted emission are across the 50 Ω LISN port.
3. AC conducted emission measurements is made over frequency range from 150 kHz to 30 MHz.
4. This measurement was performed with AC 120V / 60Hz.

3.6.3 Test Setup

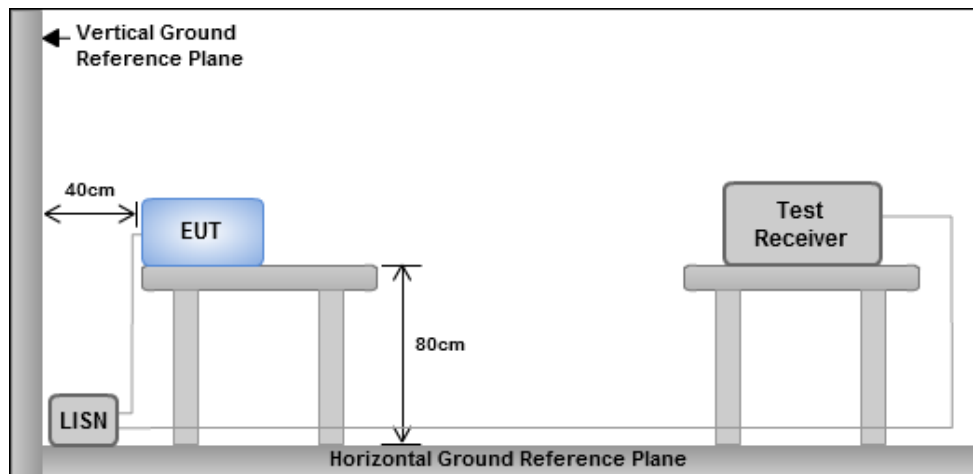

- Note: 1. Support units were connected to second LISN.
 2. Both of LISNs (AMN) are 80 cm from EUT and at least 80 cm from other units and other metal planes

3.6.4 Test Results

Refer to Appendix F.

4 Test laboratory information

Established in 2012, ICC provides foremost EMC & RF Testing and advisory consultation services by our skilled engineers and technicians. Our services employ a wide variety of advanced edge test equipment and one of the widest certification extents in the business.

International Certification Corporation (EMC and Wireless Communication Laboratory), it is our definitive objective is to institute long term, trust-based associations with our clients. The expectation we set up with our clients is based on outstanding service, practical expertise and devotion to a certified value structure. Our passion is to grant our clients with best EMC / RF services by oriented knowledgeable and accommodating staff.

Our Test sites are located at Linkou District and Kwei Shan District. Location map can be found on our website <http://www.icertifi.com.tw>.

Linkou

Tel: 886-2-2601-1640

No.30-2, Ding Fwu Tsuen, Lin Kou
District, New Taipei City, Taiwan
(R.O.C.)

Kwei Shan

Tel: 886-3-271-8666

No.3-1, Lane 6, Wen San 3rd
St., Kwei Shan Dist., Tao Yuan
City 33381, Taiwan (R.O.C.)
No.2-1, Lane 6, Wen San 3rd
St., Kwei Shan Dist., Tao Yuan
City 33381, Taiwan (R.O.C.)

Kwei Shan Site II

Tel: 886-3-271-8640

No.14-1, Lane 19, Wen San 3rd
St., Kwei Shan Dist., Tao Yuan
City 33381, Taiwan (R.O.C.)

If you have any suggestion, please feel free to contact us as below information.

Tel: 886-3-271-8666

Fax: 886-3-318-0345

Email: ICC_Service@icertifi.com.tw

==END==



Summary

Mode	Max-N dB (Hz)	Max-OBW (Hz)	ITU-Code	Min-N dB (Hz)	Min-OBW (Hz)
2.4-2.4835GHz	-	-	-	-	-
802.11b_Nss1,(1Mbps)_1TX	8.025M	14.058M	14M1G1D	7.55M	14.014M
802.11g_Nss1,(6Mbps)_1TX	15.075M	16.312M	16M3D1D	15.025M	16.291M
802.11n HT20_Nss1,(MCS0)_1TX	15.125M	17.46M	17M5D1D	15.025M	17.435M

Max-N dB = Maximum 6dB down bandwidth; Max-OBW = Maximum 99% occupied bandwidth;
 Min-N dB = Minimum 6dB down bandwidth; Min-OBW = Minimum 99% occupied bandwidth

Result

Mode	Result	Limit (Hz)	Port 1-N dB (Hz)	Port 1-OBW (Hz)
802.11b_Nss1,(1Mbps)_1TX	-	-	-	-
2412MHz	Pass	500k	8M	14.058M
2437MHz	Pass	500k	7.55M	14.029M
2462MHz	Pass	500k	8.025M	14.014M
802.11g_Nss1,(6Mbps)_1TX	-	-	-	-
2412MHz	Pass	500k	15.075M	16.312M
2437MHz	Pass	500k	15.05M	16.291M
2462MHz	Pass	500k	15.025M	16.312M
802.11n HT20_Nss1,(MCS0)_1TX	-	-	-	-
2412MHz	Pass	500k	15.05M	17.435M
2437MHz	Pass	500k	15.025M	17.435M
2462MHz	Pass	500k	15.125M	17.46M

Port X-N dB = Port X 6dB down bandwidth;
 Port X-OBW = Port X 99% occupied bandwidth



2.4-2.4835GHz_802.11b_Nss1,(1Mbps)_1TX
2412MHz

EBW

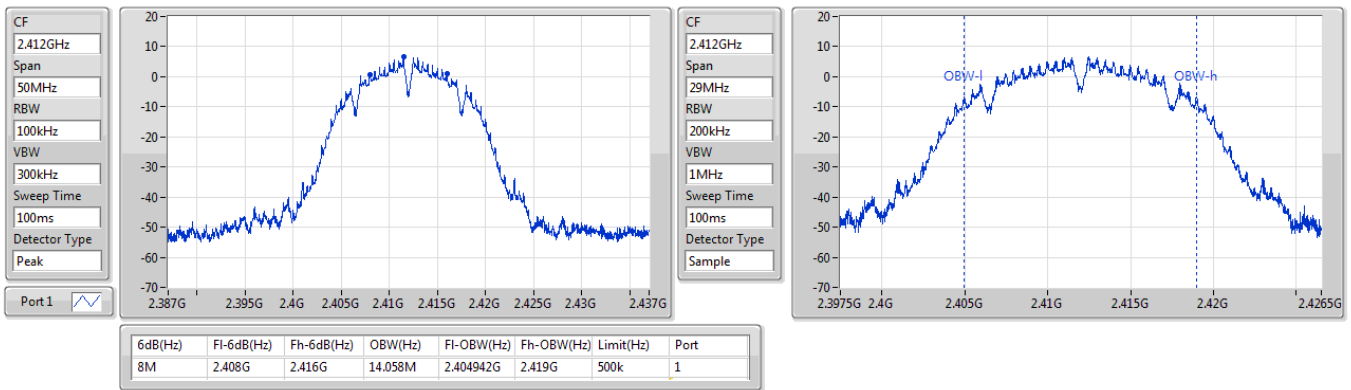

2.4-2.4835GHz_802.11b_Nss1,(1Mbps)_1TX
2437MHz

EBW

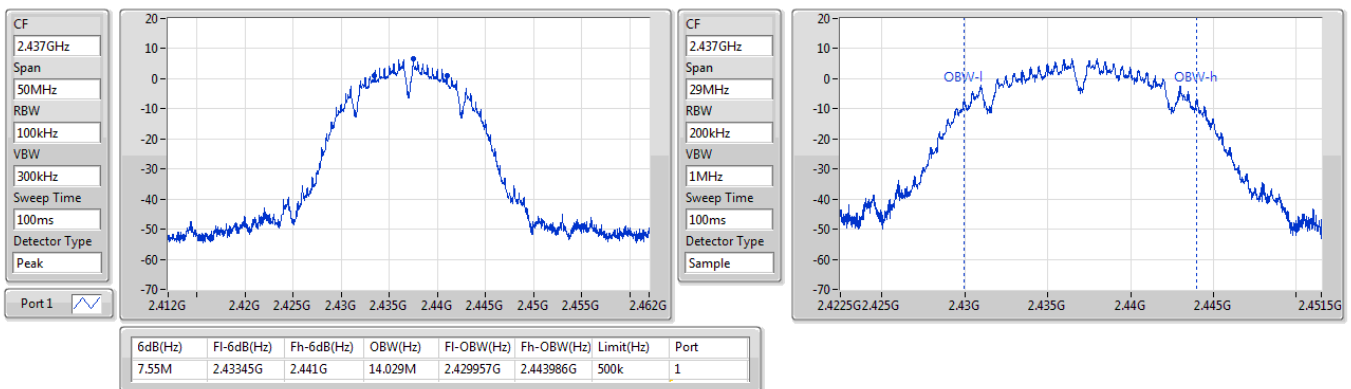



2.4-2.4835GHz_802.11b_Nss1,(1Mbps)_1TX
2462MHz

EBW

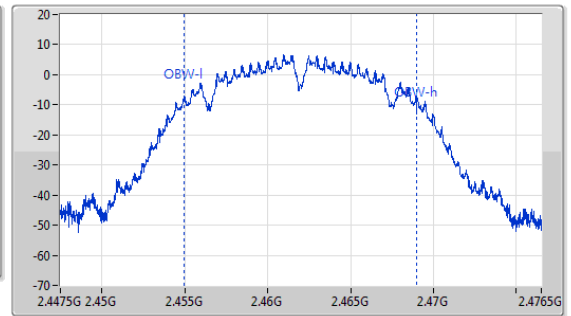
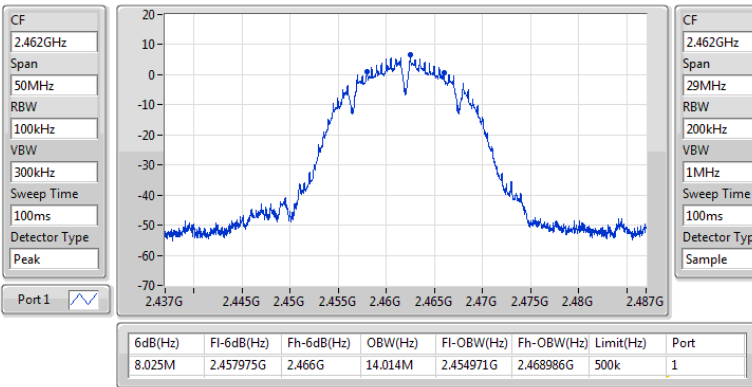

2.4-2.4835GHz_802.11g_Nss1,(6Mbps)_1TX
2412MHz

EBW

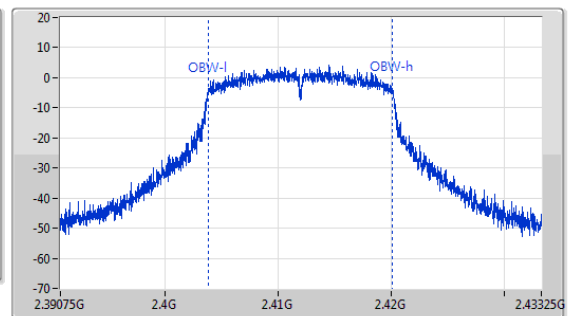
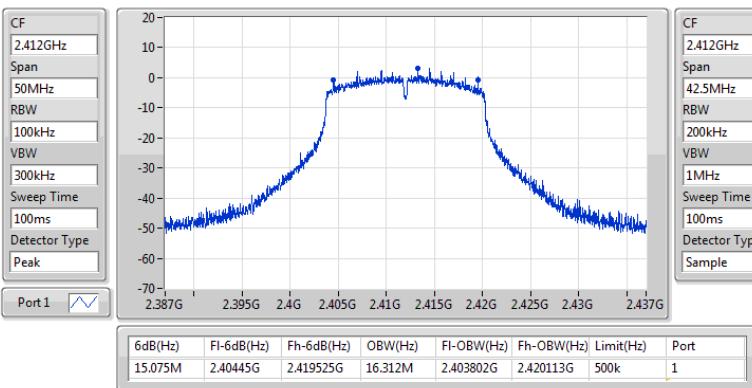



2.4-2.4835GHz_802.11g_Nss1,(6Mbps)_1TX
2437MHz

EBW

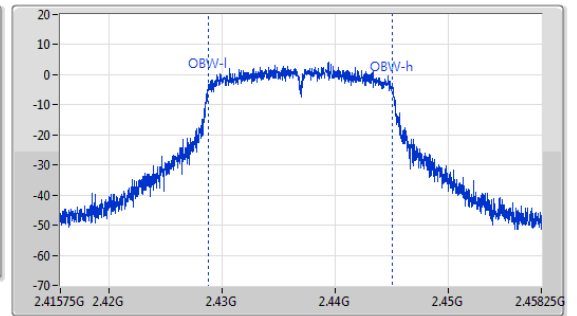
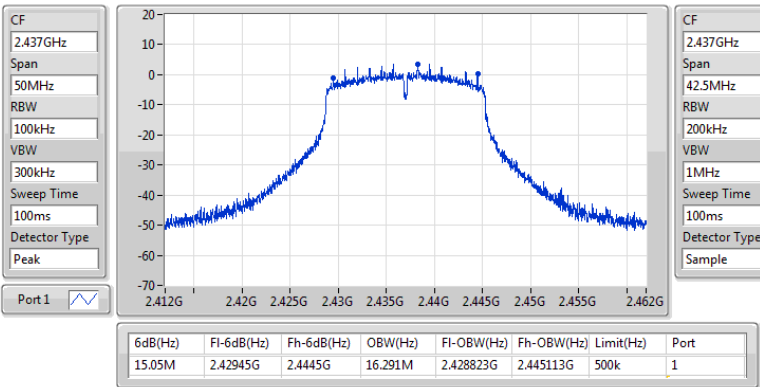

2.4-2.4835GHz_802.11g_Nss1,(6Mbps)_1TX
2462MHz

EBW

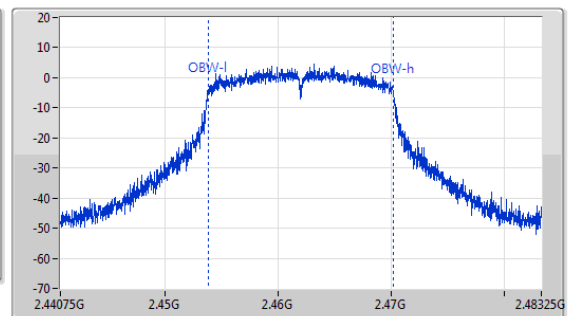
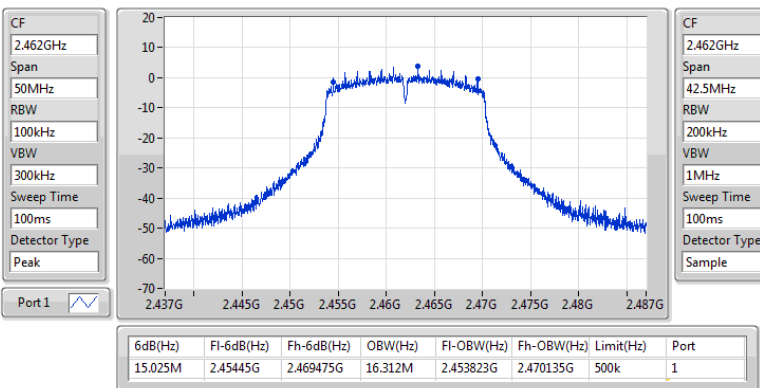

2.4-2.4835GHz_802.11n HT20_Nss1,(MCS0)_1TX
2412MHz

EBW

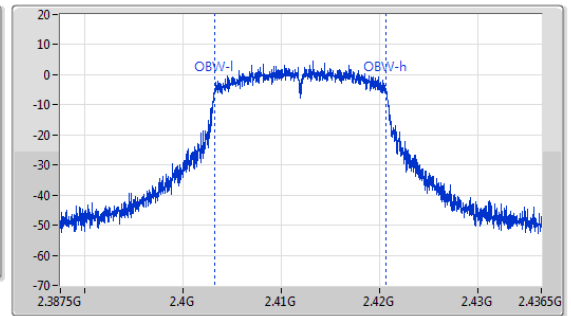
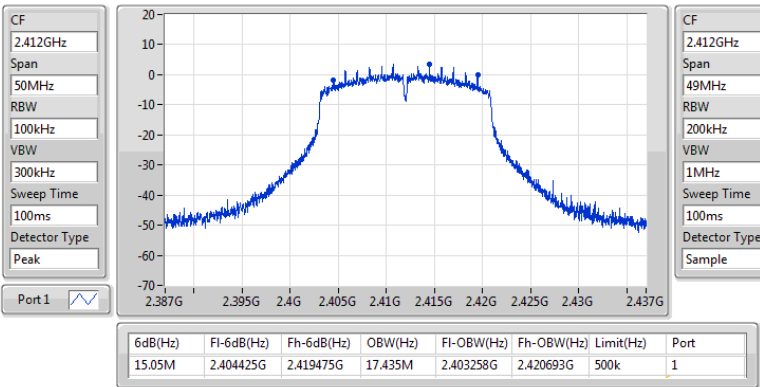

2.4-2.4835GHz_802.11n HT20_Nss1,(MCS0)_1TX
2437MHz

EBW

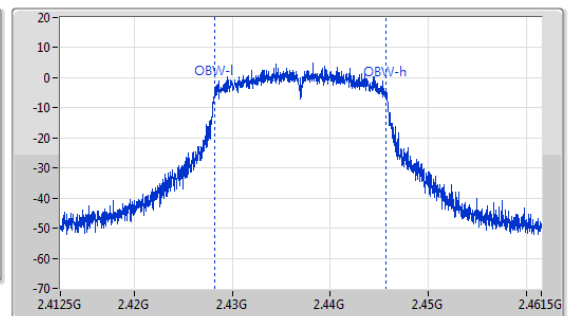
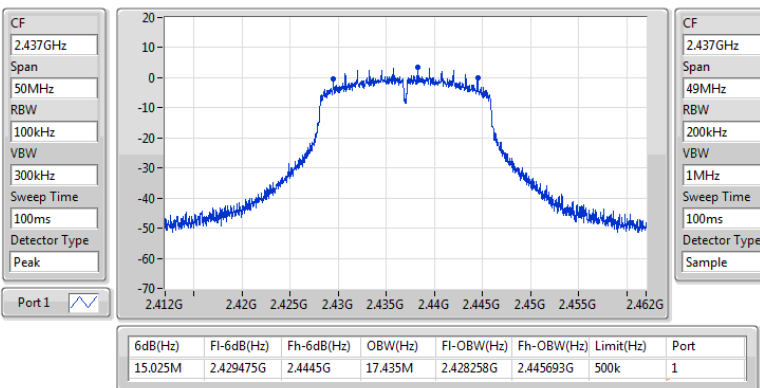



2.4-2.4835GHz_802.11n HT20_Nss1,(MCS0)_1TX
2462MHz

EBW

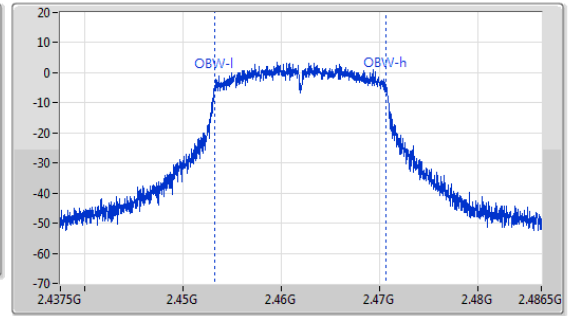
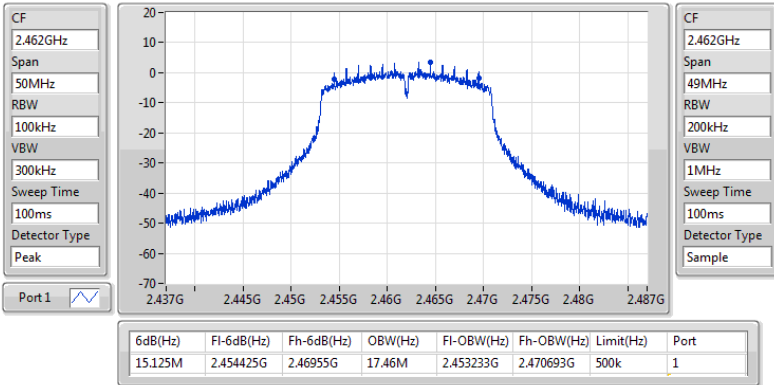

**Summary**

Mode	Total Power (dBm)	Total Power (W)
2.4-2.4835GHz	-	-
802.11b_Nss1,(1Mbps)_1TX	16.86	0.04853
802.11g_Nss1,(6Mbps)_1TX	22.96	0.19770
802.11n HT20_Nss1,(MCS0)_1TX	22.81	0.19099

Result

Mode	Result	DG (dBi)	Port 1 (dBm)	Total Power (dBm)	Power Limit (dBm)	EIRP (dBm)	EIRP Limit (dBm)
802.11b_Nss1,(1Mbps)_1TX	-	-	-	-	-	-	-
2412MHz	Pass	2.80	16.78	16.78	30.00	19.58	36.00
2437MHz	Pass	2.80	16.81	16.81	30.00	19.61	36.00
2462MHz	Pass	2.80	16.86	16.86	30.00	19.66	36.00
802.11g_Nss1,(6Mbps)_1TX	-	-	-	-	-	-	-
2412MHz	Pass	2.80	22.91	22.91	30.00	25.71	36.00
2437MHz	Pass	2.80	22.88	22.88	30.00	25.68	36.00
2462MHz	Pass	2.80	22.96	22.96	30.00	25.76	36.00
802.11n HT20_Nss1,(MCS0)_1TX	-	-	-	-	-	-	-
2412MHz	Pass	2.80	22.78	22.78	30.00	25.58	36.00
2437MHz	Pass	2.80	22.81	22.81	30.00	25.61	36.00
2462MHz	Pass	2.80	22.76	22.76	30.00	25.56	36.00

DG = Directional Gain; Port X = Port X output power



Conducted Output Power(Average)

Appendix B

Summary

Mode	Total Power (dBm)	Total Power (W)
2.4-2.4835GHz	-	-
802.11b_Nss1,(1Mbps)_1TX	14.46	0.02793
802.11g_Nss1,(6Mbps)_1TX	14.20	0.02630
802.11n HT20_Nss1,(MCS0)_1TX	14.15	0.02600

Result

Mode	Result	DG (dBi)	Port 1 (dBm)	Total Power (dBm)	Power Limit (dBm)	EIRP (dBm)	EIRP Limit (dBm)
802.11b_Nss1,(1Mbps)_1TX	-	-	-	-	-	-	-
2412MHz	Pass	2.80	14.41	14.41	-	17.21	-
2437MHz	Pass	2.80	14.45	14.45	-	17.25	-
2462MHz	Pass	2.80	14.46	14.46	-	17.26	-
802.11g_Nss1,(6Mbps)_1TX	-	-	-	-	-	-	-
2412MHz	Pass	2.80	14.12	14.12	-	16.92	-
2437MHz	Pass	2.80	14.14	14.14	-	16.94	-
2462MHz	Pass	2.80	14.2	14.20	-	17.00	-
802.11n HT20_Nss1,(MCS0)_1TX	-	-	-	-	-	-	-
2412MHz	Pass	2.80	14.02	14.02	-	16.82	-
2437MHz	Pass	2.80	14.03	14.03	-	16.83	-
2462MHz	Pass	2.80	14.15	14.15	-	16.95	-

DG = Directional Gain; Port X = Port X output power

Note : Conducted average output power is for reference



Summary

Mode	PD (dBm/RBW)
2.4-2.4835GHz	-
802.11b_Nss1,(1Mbps)_1TX	-7.20
802.11g_Nss1,(6Mbps)_1TX	-10.45
802.11n HT20_Nss1,(MCS0)_1TX	-9.38

RBW = 3kHz;

Result

Mode	Result	DG (dBi)	Port 1 (dBm/RBW)	PD (dBm/RBW)	PD Limit (dBm/RBW)
802.11b_Nss1,(1Mbps)_1TX	-	-	-	-	-
2412MHz	Pass	2.80	-8.21	-8.21	8.00
2437MHz	Pass	2.80	-8.16	-8.16	8.00
2462MHz	Pass	2.80	-7.20	-7.20	8.00
802.11g_Nss1,(6Mbps)_1TX	-	-	-	-	-
2412MHz	Pass	2.80	-10.54	-10.54	8.00
2437MHz	Pass	2.80	-10.55	-10.55	8.00
2462MHz	Pass	2.80	-10.45	-10.45	8.00
802.11n HT20_Nss1,(MCS0)_1TX	-	-	-	-	-
2412MHz	Pass	2.80	-10.95	-10.95	8.00
2437MHz	Pass	2.80	-10.06	-10.06	8.00
2462MHz	Pass	2.80	-9.38	-9.38	8.00

DG = Directional Gain; RBW = 3kHz;

PD =Power density; Port X = Port X Power Density;



2.4-2.4835GHz_802.11b_Nss1,(1Mbps)_1TX

PSD

2412MHz

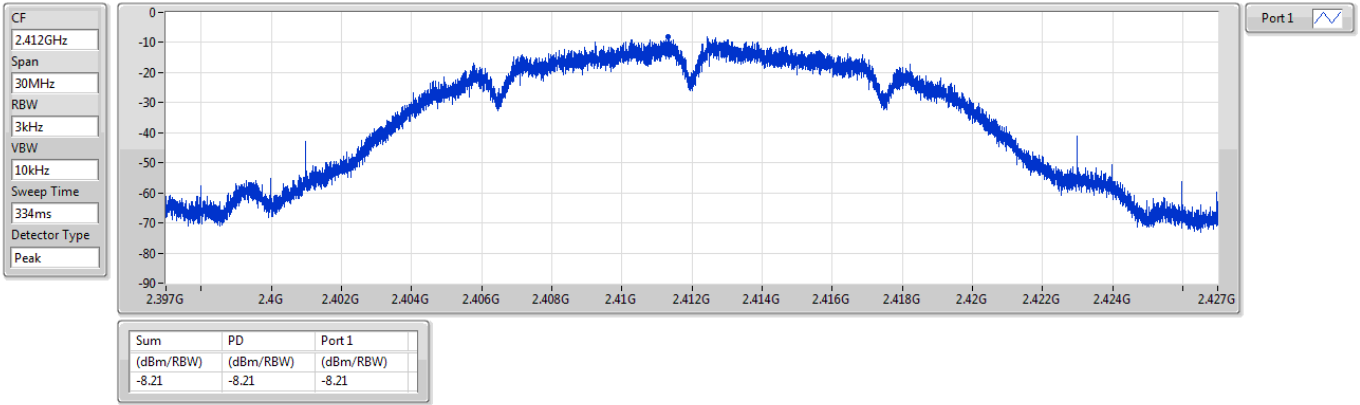

2.4-2.4835GHz_802.11b_Nss1,(1Mbps)_1TX

PSD

2437MHz

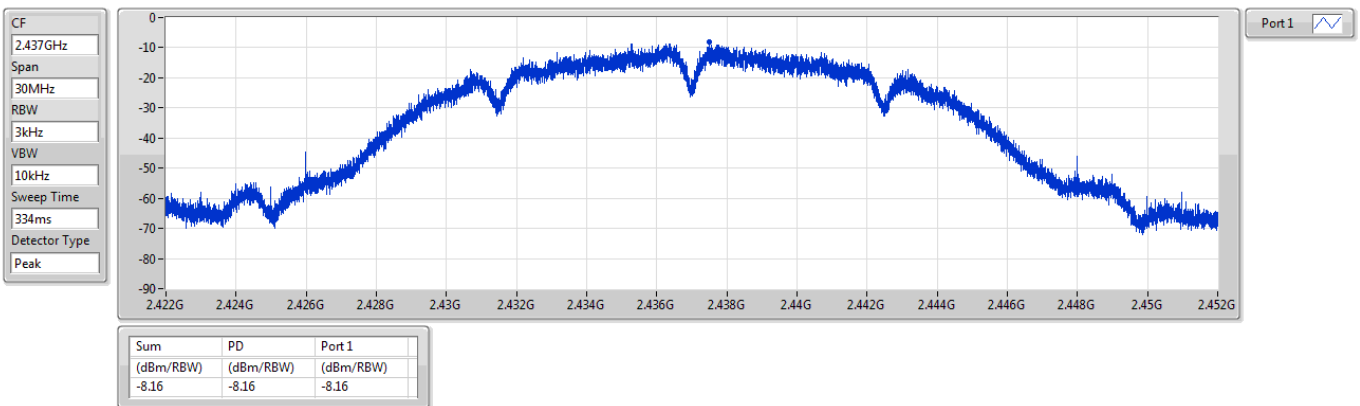



2.4-2.4835GHz_802.11b_Nss1,(1Mbps)_1TX

PSD

2462MHz

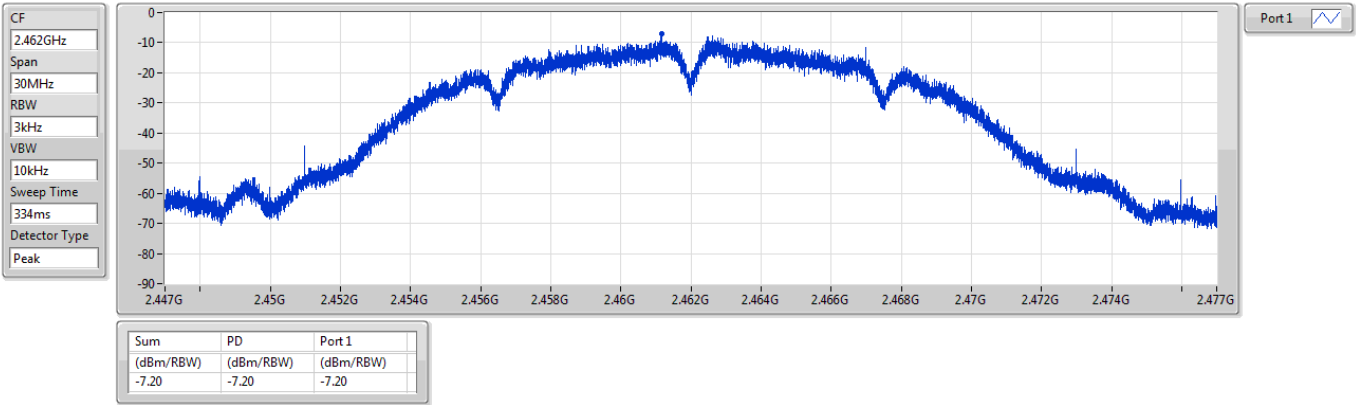

2.4-2.4835GHz_802.11g_Nss1,(6Mbps)_1TX

PSD

2412MHz

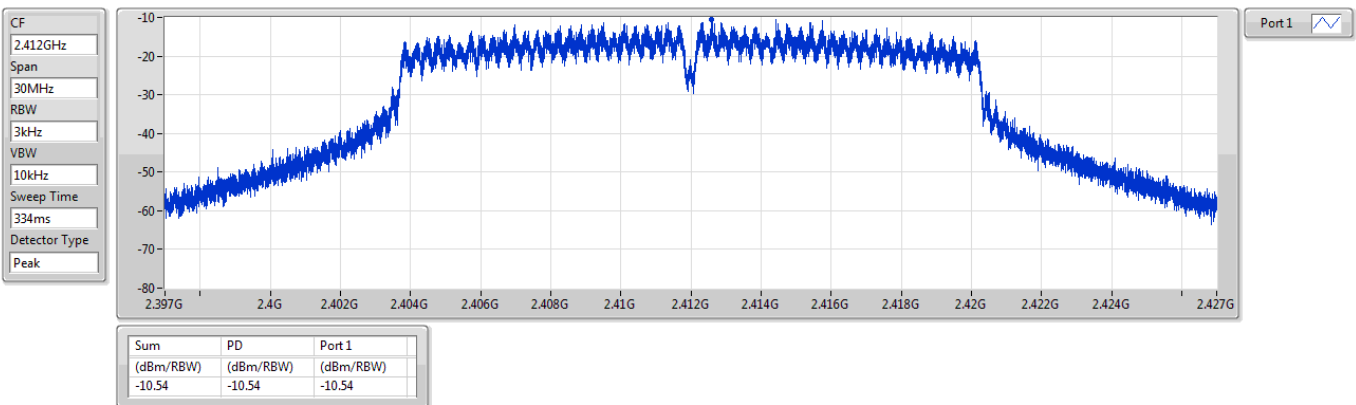



2.4-2.4835GHz_802.11g_Nss1,(6Mbps)_1TX

PSD

2437MHz

CF
2.437GHz
Span
30MHz
RBW
3kHz
VBW
10kHz
Sweep Time
334ms
Detector Type
Peak

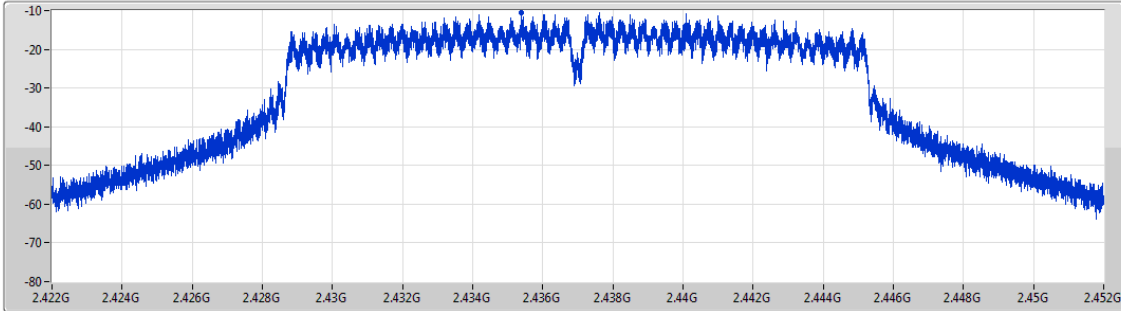

Sum	PD	Port 1
(dBm/RBW)	(dBm/RBW)	(dBm/RBW)
-10.55	-10.55	-10.55

2.4-2.4835GHz_802.11g_Nss1,(6Mbps)_1TX

PSD

2462MHz

CF
2.462GHz
Span
30MHz
RBW
3kHz
VBW
10kHz
Sweep Time
334ms
Detector Type
Peak

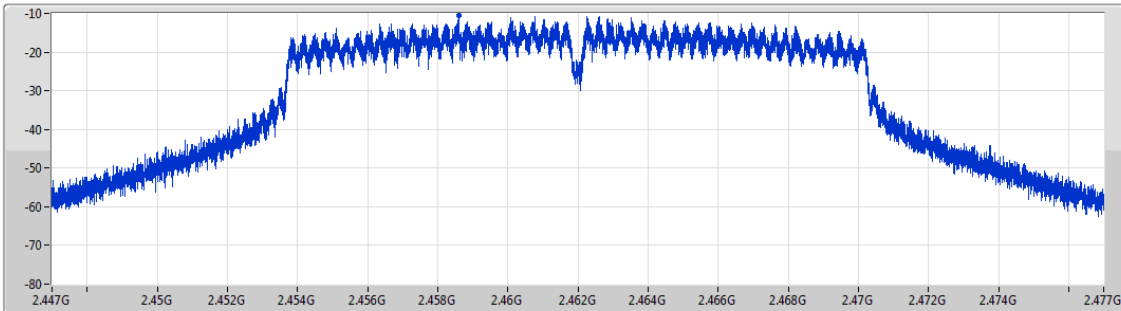

Sum	PD	Port 1
(dBm/RBW)	(dBm/RBW)	(dBm/RBW)
-10.45	-10.45	-10.45



2.4-2.4835GHz_802.11n HT20_Nss1,(MCS0)_1TX

PSD

2412MHz

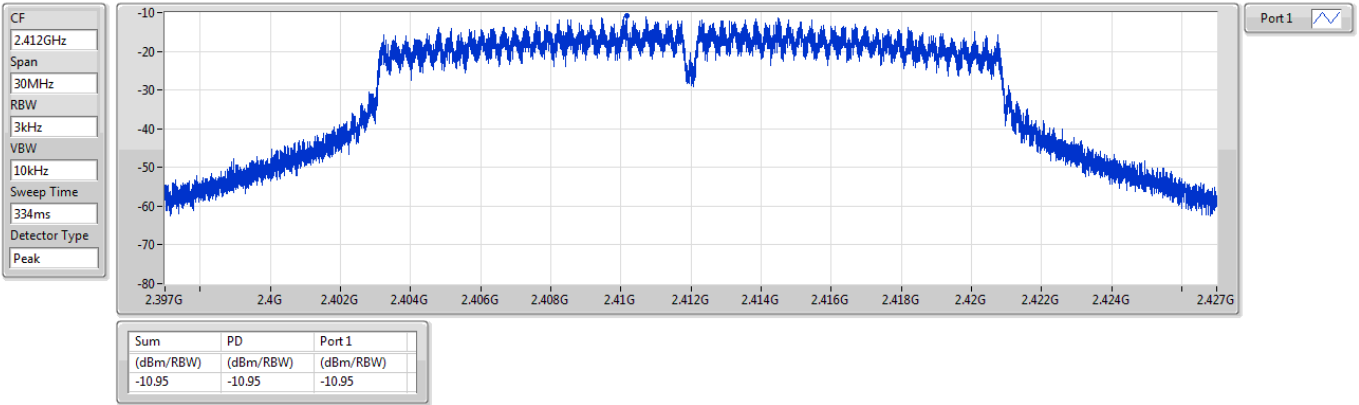

2.4-2.4835GHz_802.11n HT20_Nss1,(MCS0)_1TX

PSD

2437MHz

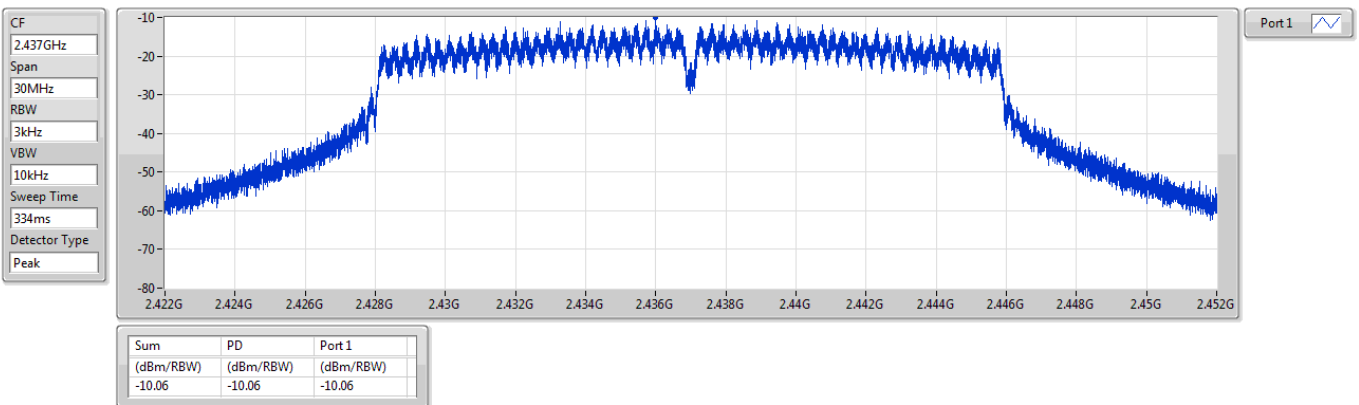



2.4-2.4835GHz_802.11n HT20_Nss1,(MCS0)_1TX

PSD

2462MHz

CF
2.462GHz
Span
30MHz
RBW
3kHz
VBW
10kHz
Sweep Time
334ms
Detector Type
Peak

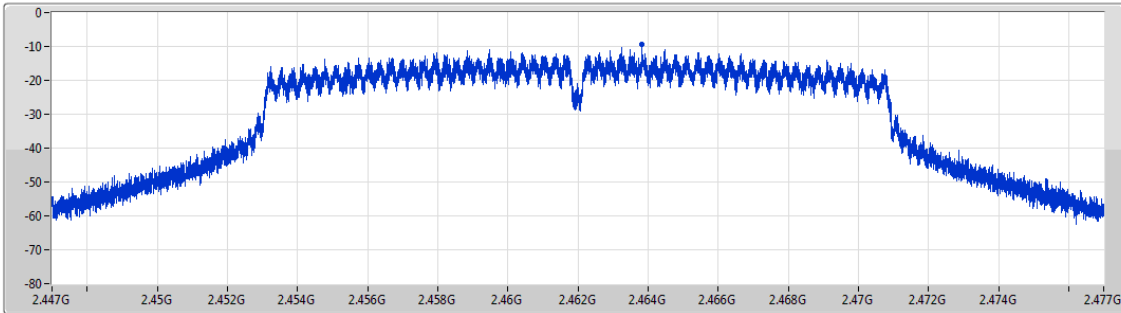

Sum	PD	Port 1
(dBm/RBW)	(dBm/RBW)	(dBm/RBW)
-9.38	-9.38	-9.38



Unwanted Emissions (Below 1GHz)

Modulation	11g	Test Freq. (MHz)	2462
Polarization	Horizontal		

Test By :Roger Lu Temperature(°C):23 Humidity(%):68

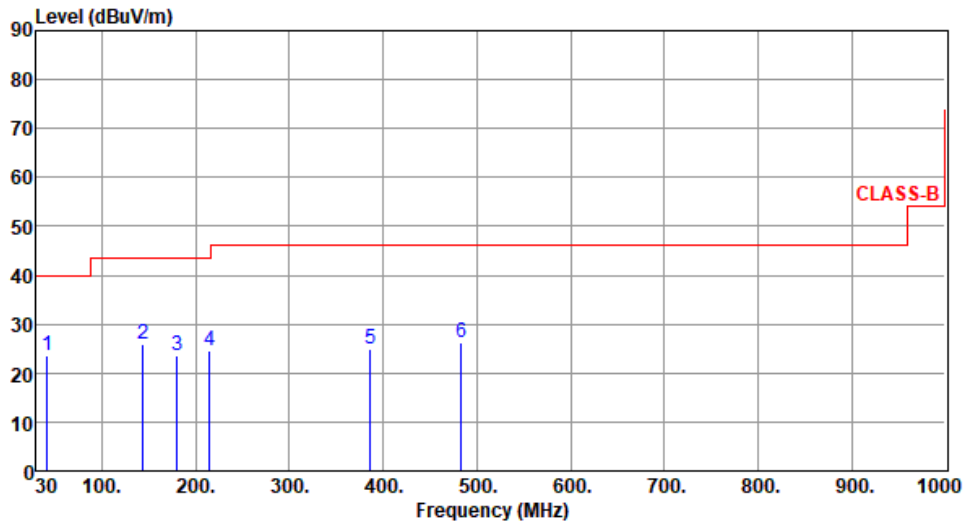

	Freq. MHz	Emission level dBuV/m	Limit dBuV/m	Margin dB	SA reading dBuV	Factor dB/m	Remark	ANT High cm	Turn Table deg
1	41.64	23.50	40.00	-16.50	32.16	-8.66	Peak	---	---
2	143.49	25.86	43.50	-17.64	34.94	-9.08	Peak	---	---
3	180.35	23.73	43.50	-19.77	34.20	-10.47	Peak	---	---
4	215.27	24.52	43.50	-18.98	36.45	-11.93	Peak	---	---
5	385.99	24.80	46.00	-21.20	30.69	-5.89	Peak	---	---
6	482.99	26.37	46.00	-19.63	29.99	-3.62	Peak	---	---

Note 1: Emission Level (dBuV/m) = SA Reading (dBuV) + Factor* (dB/m)

*Factor includes antenna factor , cable loss and amplifier gain

Note 2: Margin (dB) = Emission level (dBuV/m) – Limit (dBuV/m).

Note 3: All spurious emissions below 30MHz are more than 20 dB below the limit.



Modulation	11g	Test Freq. (MHz)	2462
Polarization	Vertical		

Test By : Roger Lu Temperature(°C): 23 Humidity(%): 68

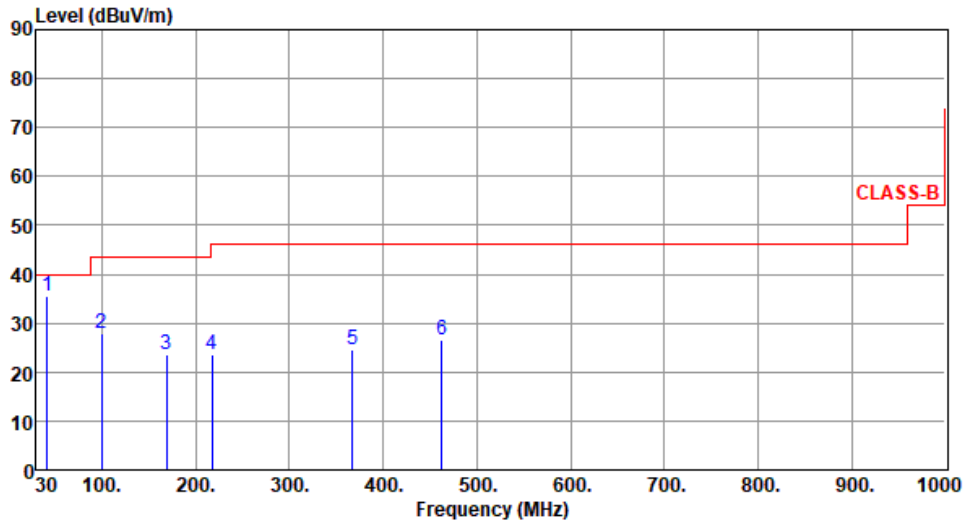

	Freq. MHz	Emission level dBuV/m	Limit dBuV/m	Margin dB	SA reading dBuV	Factor dB/m	Remark	ANT High cm	Turn Table deg
1	41.64	35.56	40.00	-4.44	44.22	-8.66	Peak	---	---
2	99.84	27.79	43.50	-15.71	41.25	-13.46	Peak	---	---
3	168.71	23.54	43.50	-19.96	32.85	-9.31	Peak	---	---
4	217.21	23.41	46.00	-22.59	35.34	-11.93	Peak	---	---
5	367.56	24.68	46.00	-21.32	31.25	-6.57	Peak	---	---
6	462.62	26.65	46.00	-19.35	30.56	-3.91	Peak	---	---

Note 1: Emission Level (dBuV/m) = SA Reading (dBuV) + Factor* (dB/m)

*Factor includes antenna factor , cable loss and amplifier gain

Note 2: Margin (dB) = Emission level (dBuV/m) – Limit (dBuV/m).

Note 3: All spurious emissions below 30MHz are more than 20 dB below the limit.



Unwanted Emission (Above 1GHz) for 11b

Modulation	11b	Test Freq. (MHz)	2412						
Polarization	Horizontal								
Test By : Akun Chung- Temperature(°C):24 Humidity(%):66									
	Freq. MHz	Emission level dBuV/m	Limit dBuV/m	Margin dB	SA reading dBuV	Factor dB/m	Remark	ANT High cm	Turn Table deg
1	2390.00	37.58	54.00	-16.42	42.23	-4.65	Average	199	203
2	2390.00	50.72	74.00	-23.28	55.37	-4.65	Peak	199	203
3	4824.00	34.29	54.00	-19.71	34.82	-0.53	Average	281	351
4	4824.00	44.62	74.00	-29.38	45.15	-0.53	Peak	281	351
5	12060.00	42.10	54.00	-11.90	35.73	6.37	Average	100	51
6	12060.00	55.92	74.00	-18.08	49.55	6.37	Peak	100	51

Note 1: Emission Level (dBuV/m) = SA Reading (dBuV) + Factor* (dB/m)
 *Factor includes antenna factor , cable loss and amplifier gain
 Note 2: Margin (dB) = Emission level (dBuV/m) – Limit (dBuV/m).



Modulation	11b	Test Freq. (MHz)	2412
Polarization	Vertical		

Test By :Akun Chung- Temperature(°C):24 Humidity(%):66

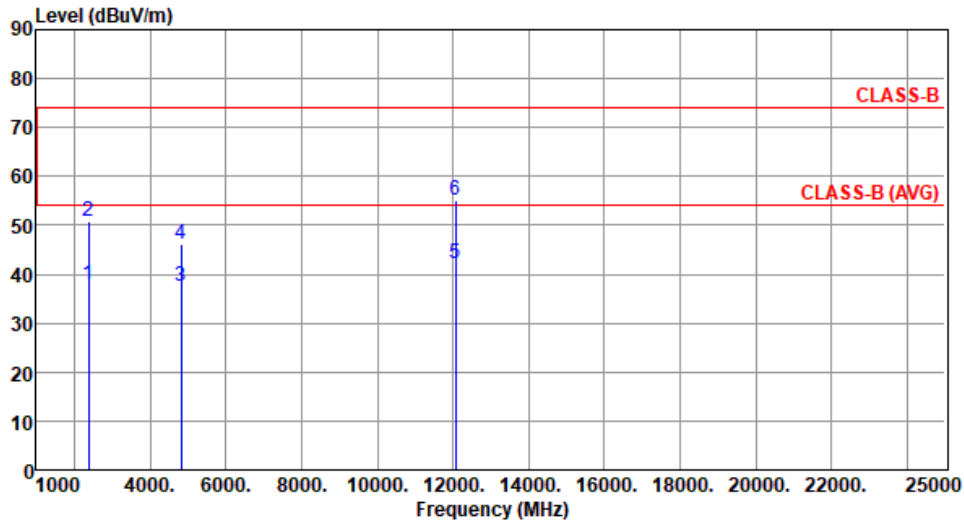

	Freq. MHz	Emission level dBuV/m	Limit dBuV/m	Margin dB	SA reading dBuV	Factor dB/m	Remark	ANT High cm	Turn Table deg
1	2390.00	37.88	54.00	-16.12	42.53	-4.65	Average	390	15
2	2390.00	50.91	74.00	-23.09	55.56	-4.65	Peak	390	15
3	4824.00	37.46	54.00	-16.54	37.99	-0.53	Average	100	32
4	4824.00	46.12	74.00	-27.88	46.65	-0.53	Peak	100	32
5	12060.00	42.15	54.00	-11.85	35.78	6.37	Average	100	47
6	12060.00	55.01	74.00	-18.99	48.64	6.37	Peak	100	47

Note 1: Emission Level (dBuV/m) = SA Reading (dBuV) + Factor* (dB/m)

*Factor includes antenna factor , cable loss and amplifier gain

Note 2: Margin (dB) = Emission level (dBuV/m) – Limit (dBuV/m).



Modulation	11b	Test Freq. (MHz)	2437
Polarization	Horizontal		

Test By :Akun Chung- Temperature(°C):24 Humidity(%):66

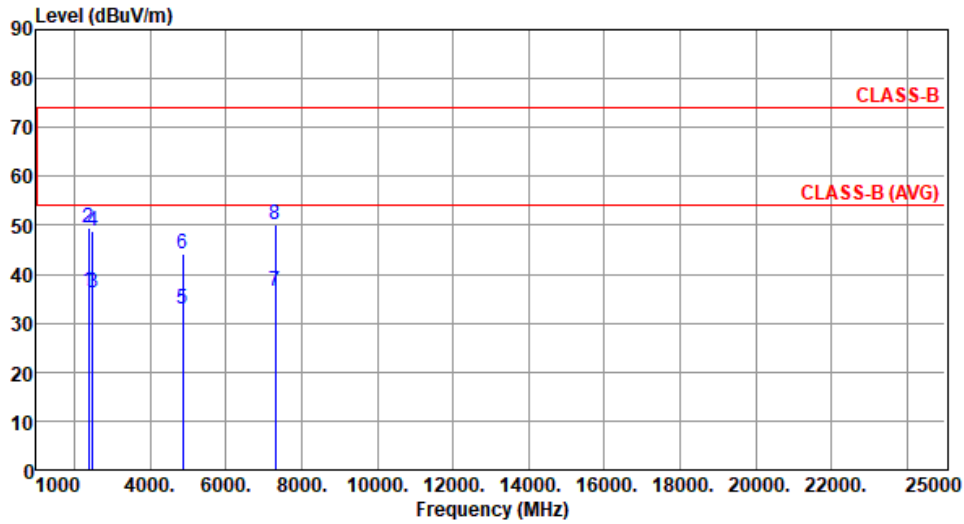

	Freq. MHz	Emission level dBuV/m	Limit dBuV/m	Margin dB	SA reading dBuV	Factor dB/m	Remark	ANT High cm	Turn Table deg
1	2390.00	36.53	54.00	-17.47	41.18	-4.65	Average	222	218
2	2390.00	49.60	74.00	-24.40	54.25	-4.65	Peak	222	218
3	2483.50	36.24	54.00	-17.76	41.13	-4.89	Average	222	218
4	2483.50	48.84	74.00	-25.16	53.73	-4.89	Peak	222	218
5	4874.00	32.97	54.00	-21.03	33.51	-0.54	Average	114	143
6	4874.00	44.23	74.00	-29.77	44.77	-0.54	Peak	114	143
7	7311.00	36.57	54.00	-17.43	31.35	5.22	Average	100	24
8	7311.00	50.23	74.00	-23.77	45.01	5.22	Peak	100	24

Note 1: Emission Level (dBuV/m) = SA Reading (dBuV) + Factor* (dB/m)

*Factor includes antenna factor , cable loss and amplifier gain

Note 2: Margin (dB) = Emission level (dBuV/m) – Limit (dBuV/m).



Modulation	11b	Test Freq. (MHz)	2437																																																																																											
Polarization	Vertical																																																																																													
Test By : Akun Chung- Temperature(°C):24 Humidity(%):66																																																																																														
	<table border="1"> <thead> <tr> <th></th> <th>Freq. MHz</th> <th>Emission level dBuV/m</th> <th>Limit dBuV/m</th> <th>Margin dB</th> <th>SA reading dBuV</th> <th>Factor dB/m</th> <th>Remark</th> <th>ANT High cm</th> <th>Turn Table deg</th> </tr> </thead> <tbody> <tr> <td>1</td> <td>2390.00</td> <td>36.38</td> <td>54.00</td> <td>-17.62</td> <td>41.03</td> <td>-4.65</td> <td>Average</td> <td>390</td> <td>18</td> </tr> <tr> <td>2</td> <td>2390.00</td> <td>49.30</td> <td>74.00</td> <td>-24.70</td> <td>53.95</td> <td>-4.65</td> <td>Peak</td> <td>390</td> <td>18</td> </tr> <tr> <td>3</td> <td>2483.50</td> <td>36.33</td> <td>54.00</td> <td>-17.67</td> <td>41.22</td> <td>-4.89</td> <td>Average</td> <td>390</td> <td>18</td> </tr> <tr> <td>4</td> <td>2483.50</td> <td>49.63</td> <td>74.00</td> <td>-24.37</td> <td>54.52</td> <td>-4.89</td> <td>Peak</td> <td>390</td> <td>18</td> </tr> <tr> <td>5</td> <td>4874.00</td> <td>37.70</td> <td>54.00</td> <td>-16.30</td> <td>38.24</td> <td>-0.54</td> <td>Average</td> <td>100</td> <td>309</td> </tr> <tr> <td>6</td> <td>4874.00</td> <td>47.25</td> <td>74.00</td> <td>-26.75</td> <td>47.79</td> <td>-0.54</td> <td>Peak</td> <td>100</td> <td>309</td> </tr> <tr> <td>7</td> <td>7311.00</td> <td>37.46</td> <td>54.00</td> <td>-16.54</td> <td>32.24</td> <td>5.22</td> <td>Average</td> <td>100</td> <td>68</td> </tr> <tr> <td>8</td> <td>7311.00</td> <td>50.18</td> <td>74.00</td> <td>-23.82</td> <td>44.96</td> <td>5.22</td> <td>Peak</td> <td>100</td> <td>68</td> </tr> </tbody> </table>		Freq. MHz	Emission level dBuV/m	Limit dBuV/m	Margin dB	SA reading dBuV	Factor dB/m	Remark	ANT High cm	Turn Table deg	1	2390.00	36.38	54.00	-17.62	41.03	-4.65	Average	390	18	2	2390.00	49.30	74.00	-24.70	53.95	-4.65	Peak	390	18	3	2483.50	36.33	54.00	-17.67	41.22	-4.89	Average	390	18	4	2483.50	49.63	74.00	-24.37	54.52	-4.89	Peak	390	18	5	4874.00	37.70	54.00	-16.30	38.24	-0.54	Average	100	309	6	4874.00	47.25	74.00	-26.75	47.79	-0.54	Peak	100	309	7	7311.00	37.46	54.00	-16.54	32.24	5.22	Average	100	68	8	7311.00	50.18	74.00	-23.82	44.96	5.22	Peak	100	68			
	Freq. MHz	Emission level dBuV/m	Limit dBuV/m	Margin dB	SA reading dBuV	Factor dB/m	Remark	ANT High cm	Turn Table deg																																																																																					
1	2390.00	36.38	54.00	-17.62	41.03	-4.65	Average	390	18																																																																																					
2	2390.00	49.30	74.00	-24.70	53.95	-4.65	Peak	390	18																																																																																					
3	2483.50	36.33	54.00	-17.67	41.22	-4.89	Average	390	18																																																																																					
4	2483.50	49.63	74.00	-24.37	54.52	-4.89	Peak	390	18																																																																																					
5	4874.00	37.70	54.00	-16.30	38.24	-0.54	Average	100	309																																																																																					
6	4874.00	47.25	74.00	-26.75	47.79	-0.54	Peak	100	309																																																																																					
7	7311.00	37.46	54.00	-16.54	32.24	5.22	Average	100	68																																																																																					
8	7311.00	50.18	74.00	-23.82	44.96	5.22	Peak	100	68																																																																																					
Note 1: Emission Level (dBuV/m) = SA Reading (dBuV) + Factor* (dB/m) *Factor includes antenna factor , cable loss and amplifier gain Note 2: Margin (dB) = Emission level (dBuV/m) – Limit (dBuV/m).																																																																																														



Modulation	11b	Test Freq. (MHz)	2462
Polarization	Horizontal		

Test By : Akun Chung- Temperature(°C): 24 Humidity(%): 66

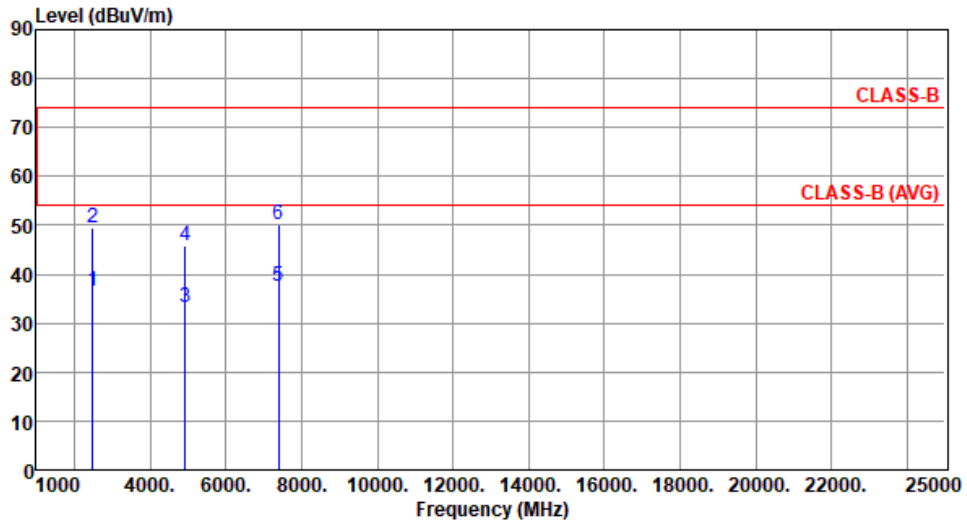

	Freq. MHz	Emission level dBuV/m	Limit dBuV/m	Margin dB	SA reading dBuV	Factor dB/m	Remark	ANT High cm	Turn Table deg
1	2483.50	36.64	54.00	-17.36	41.53	-4.89	Average	219	221
2	2483.50	49.53	74.00	-24.47	54.42	-4.89	Peak	219	221
3	4924.00	33.24	54.00	-20.76	33.75	-0.51	Average	100	141
4	4924.00	45.73	74.00	-28.27	46.24	-0.51	Peak	100	141
5	7386.00	37.40	54.00	-16.60	32.33	5.07	Average	100	79
6	7386.00	50.30	74.00	-23.70	45.23	5.07	Peak	100	79

Note 1: Emission Level (dBuV/m) = SA Reading (dBuV) + Factor* (dB/m)

*Factor includes antenna factor , cable loss and amplifier gain

Note 2: Margin (dB) = Emission level (dBuV/m) – Limit (dBuV/m).



Modulation	11b	Test Freq. (MHz)	2462
Polarization	Vertical		

Test By : Akun Chung- Temperature(°C): 24 Humidity(%): 66

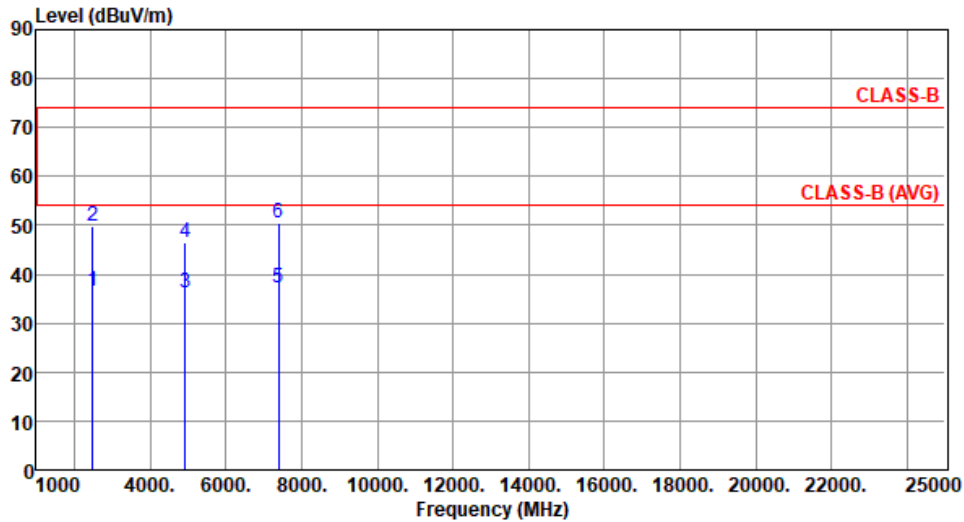

	Freq. MHz	Emission level dBuV/m	Limit dBuV/m	Margin dB	SA reading dBuV	Factor dB/m	Remark	ANT High cm	Turn Table deg
1	2483.50	36.50	54.00	-17.50	41.39	-4.89	Average	216	2
2	2483.50	49.66	74.00	-24.34	54.55	-4.89	Peak	216	2
3	4924.00	36.32	54.00	-17.68	36.83	-0.51	Average	100	310
4	4924.00	46.66	74.00	-27.34	47.17	-0.51	Peak	100	310
5	7386.00	37.30	54.00	-16.70	32.23	5.07	Average	100	34
6	7386.00	50.62	74.00	-23.38	45.55	5.07	Peak	100	34

Note 1: Emission Level (dBuV/m) = SA Reading (dBuV) + Factor* (dB/m)

*Factor includes antenna factor , cable loss and amplifier gain

Note 2: Margin (dB) = Emission level (dBuV/m) – Limit (dBuV/m).



Unwanted Emissions (Above 1GHz) for 11g

Modulation	11g	Test Freq. (MHz)	2412						
Polarization	Horizontal								
Test By :Akun Chung- Temperature(°C):24 Humidity(%):66									
	Freq. MHz	Emission level dBuV/m	Limit dBuV/m	Margin dB	SA reading dBuV	Factor dB/m	Remark	ANT High cm	Turn Table deg
1	2390.00	39.45	54.00	-14.55	44.10	-4.65	Average	122	226
2	2390.00	55.35	74.00	-18.65	60.00	-4.65	Peak	122	226
3	4824.00	31.04	54.00	-22.96	31.57	-0.53	Average	100	157
4	4824.00	44.02	74.00	-29.98	44.55	-0.53	Peak	100	157
5	12060.00	42.17	54.00	-11.83	35.80	6.37	Average	100	34
6	12060.00	55.22	74.00	-18.78	48.85	6.37	Peak	100	34

Note 1: Emission Level (dBuV/m) = SA Reading (dBuV) + Factor* (dB/m)
 *Factor includes antenna factor , cable loss and amplifier gain
 Note 2: Margin (dB) = Emission level (dBuV/m) – Limit (dBuV/m).



Modulation	11g	Test Freq. (MHz)	2412
Polarization	Vertical		

Test By :Akun Chung- Temperature(°C):24 Humidity(%):66

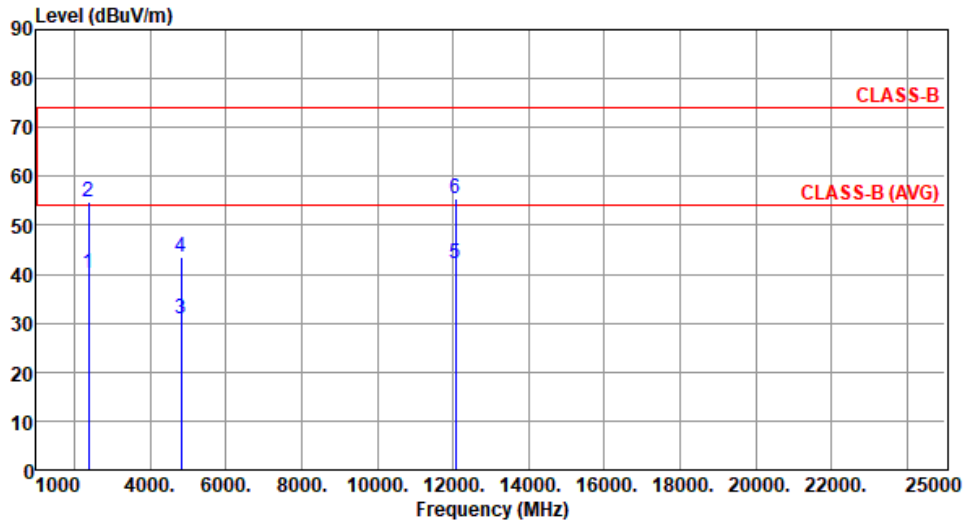

	Freq. MHz	Emission level dBUV/m	Limit dBUV/m	Margin dB	SA reading dBUV	Factor dB/m	Remark	ANT High cm	Turn Table deg
1	2390.00	40.19	54.00	-13.81	44.84	-4.65	Average	197	196
2	2390.00	54.96	74.00	-19.04	59.61	-4.65	Peak	197	196
3	4824.00	30.83	54.00	-23.17	31.36	-0.53	Average	100	179
4	4824.00	43.39	74.00	-30.61	43.92	-0.53	Peak	100	179
5	12060.00	42.21	54.00	-11.79	35.84	6.37	Average	100	56
6	12060.00	55.32	74.00	-18.68	48.95	6.37	Peak	100	56

Note 1: Emission Level (dBUV/m) = SA Reading (dBUV) + Factor* (dB/m)

*Factor includes antenna factor , cable loss and amplifier gain

Note 2: Margin (dB) = Emission level (dBUV/m) – Limit (dBUV/m).



Modulation	11g	Test Freq. (MHz)	2437
Polarization	Horizontal		

Test By :Akun Chung- Temperature(°C):24 Humidity(%):66

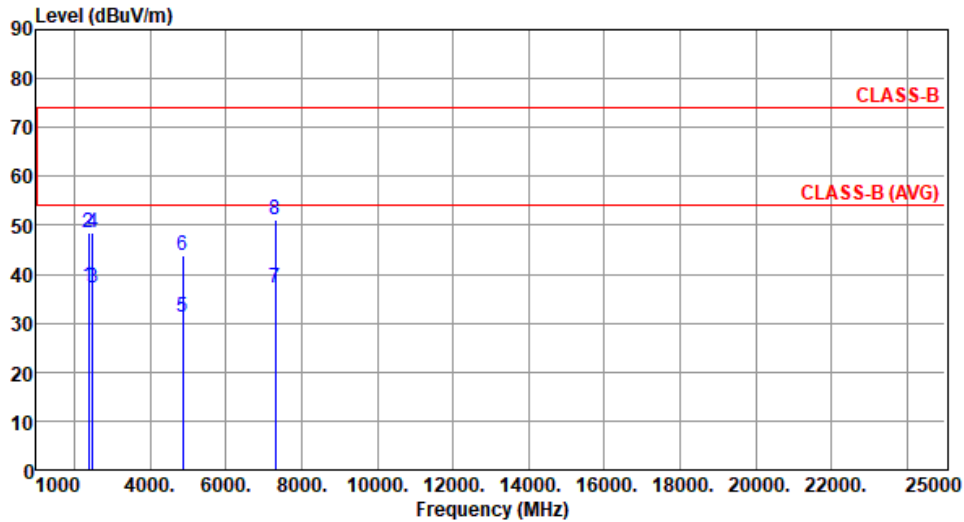

	Freq. MHz	Emission level dBuV/m	Limit dBuV/m	Margin dB	SA reading dBuV	Factor dB/m	Remark	ANT High cm	Turn Table deg
1	2390.00	37.53	54.00	-16.47	42.18	-4.65	Average	124	219
2	2390.00	48.46	74.00	-25.54	53.11	-4.65	Peak	124	219
3	2483.50	37.13	54.00	-16.87	42.02	-4.89	Average	124	219
4	2483.50	48.38	74.00	-25.62	53.27	-4.89	Peak	124	219
5	4874.00	31.27	54.00	-22.73	31.81	-0.54	Average	100	161
6	4874.00	43.72	74.00	-30.28	44.26	-0.54	Peak	100	161
7	7311.00	37.14	54.00	-16.86	31.92	5.22	Average	100	81
8	7311.00	51.08	74.00	-22.92	45.86	5.22	Peak	100	81

Note 1: Emission Level (dBuV/m) = SA Reading (dBuV) + Factor* (dB/m)

*Factor includes antenna factor , cable loss and amplifier gain

Note 2: Margin (dB) = Emission level (dBuV/m) – Limit (dBuV/m).



Modulation	11g	Test Freq. (MHz)	2437						
Polarization	Vertical								
Test By :Akun Chung- Temperature(°C):24 Humidity(%):66									
	Freq.	Emission level	Limit	Margin	SA reading	Factor	Remark	ANT High	Turn Table
	MHz	dBuV/m	dBuV/m	dB	dBuV	dB/m		cm	deg
1	2390.00	37.40	54.00	-16.60	42.05	-4.65	Average	192	213
2	2390.00	48.53	74.00	-25.47	53.18	-4.65	Peak	192	213
3	2483.50	37.25	54.00	-16.75	42.14	-4.89	Average	192	213
4	2483.50	48.58	74.00	-25.42	53.47	-4.89	Peak	192	213
5	4874.00	31.80	54.00	-22.20	32.34	-0.54	Average	100	211
6	4874.00	44.75	74.00	-29.25	45.29	-0.54	Peak	100	211
7	7311.00	37.29	54.00	-16.71	32.07	5.22	Average	100	52
8	7311.00	51.08	74.00	-22.92	45.86	5.22	Peak	100	52

Note 1: Emission Level (dBuV/m) = SA Reading (dBuV) + Factor* (dB/m)
 *Factor includes antenna factor , cable loss and amplifier gain
 Note 2: Margin (dB) = Emission level (dBuV/m) – Limit (dBuV/m).



Modulation	11g	Test Freq. (MHz)	2462
Polarization	Horizontal		

Test By :Akun Chung- Temperature(°C):24 Humidity(%):66

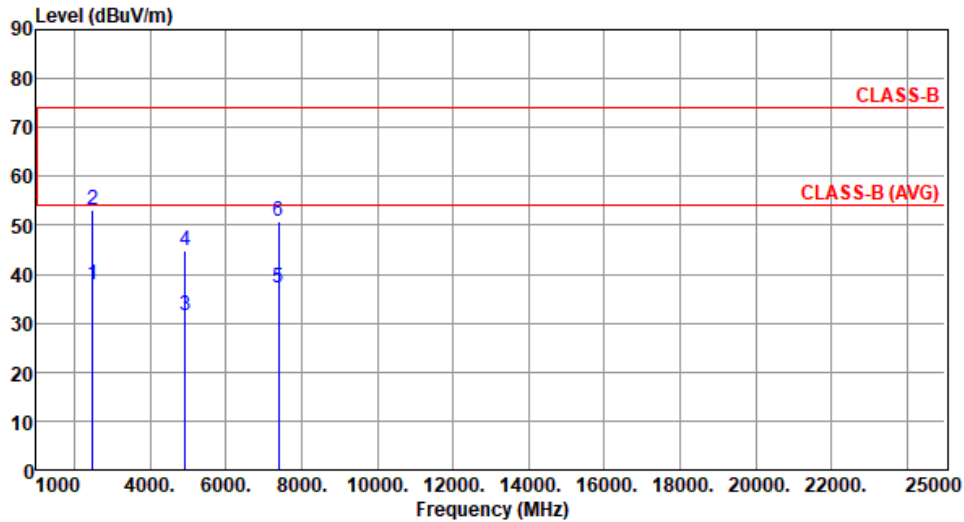

	Freq. MHz	Emission level dBuV/m	Limit dBuV/m	Margin dB	SA reading dBuV	Factor dB/m	Remark	ANT High cm	Turn Table deg
1	2483.50	37.93	54.00	-16.07	42.82	-4.89	Average	145	238
2	2483.50	53.22	74.00	-20.78	58.11	-4.89	Peak	145	238
3	4924.00	31.51	54.00	-22.49	32.02	-0.51	Average	100	145
4	4924.00	44.73	74.00	-29.27	45.24	-0.51	Peak	100	145
5	7386.00	37.12	54.00	-16.88	32.05	5.07	Average	100	85
6	7386.00	50.70	74.00	-23.30	45.63	5.07	Peak	100	85

Note 1: Emission Level (dBuV/m) = SA Reading (dBuV) + Factor* (dB/m)

*Factor includes antenna factor , cable loss and amplifier gain

Note 2: Margin (dB) = Emission level (dBuV/m) – Limit (dBuV/m).



Modulation	11g	Test Freq. (MHz)	2462
Polarization	Vertical		

Test By : Akun Chung- Temperature(°C): 24 Humidity(%): 66

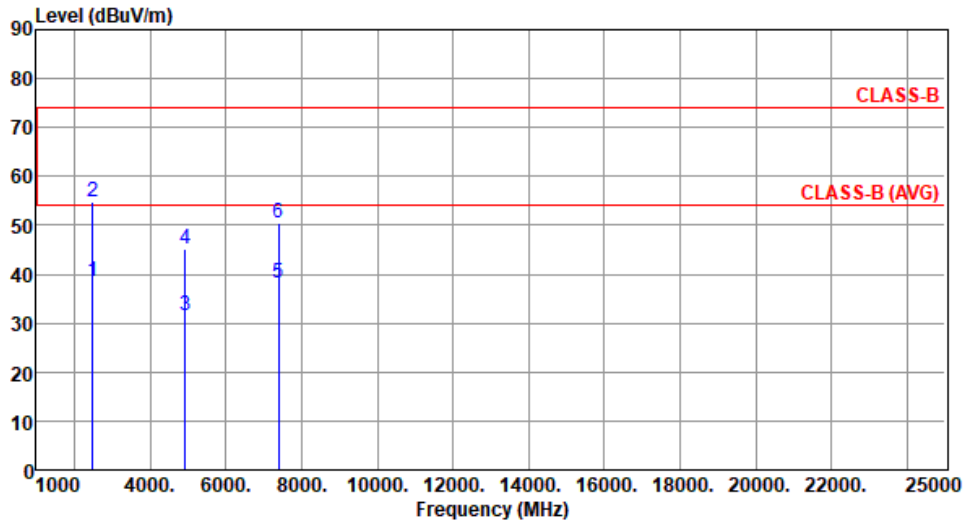

	Freq. MHz	Emission level dBuV/m	Limit dBuV/m	Margin dB	SA reading dBuV	Factor dB/m	Remark	ANT High cm	Turn Table deg
1	2483.50	38.37	54.00	-15.63	43.26	-4.89	Average	243	181
2	2483.50	54.65	74.00	-19.35	59.54	-4.89	Peak	243	181
3	4924.00	31.64	54.00	-22.36	32.15	-0.51	Average	100	127
4	4924.00	45.33	74.00	-28.67	45.84	-0.51	Peak	100	127
5	7386.00	38.30	54.00	-15.70	33.23	5.07	Average	100	61
6	7386.00	50.44	74.00	-23.56	45.37	5.07	Peak	100	61

Note 1: Emission Level (dBuV/m) = SA Reading (dBuV) + Factor* (dB/m)

*Factor includes antenna factor , cable loss and amplifier gain

Note 2: Margin (dB) = Emission level (dBuV/m) – Limit (dBuV/m).



Unwanted Emissions (Above 1GHz) for HT20

Modulation	HT20	Test Freq. (MHz)	2412						
Polarization	Horizontal								
Test By :Akun Chung- Temperature(°C):24 Humidity(%):66									
	Freq. MHz	Emission level dBuV/m	Limit dBuV/m	Margin dB	SA reading dBuV	Factor dB/m	Remark	ANT High cm	Turn Table deg
1	2390.00	39.05	54.00	-14.95	43.70	-4.65	Average	208	191
2	2390.00	54.06	74.00	-19.94	58.71	-4.65	Peak	208	191
3	4824.00	31.12	54.00	-22.88	31.65	-0.53	Average	100	150
4	4824.00	44.43	74.00	-29.57	44.96	-0.53	Peak	100	150
5	12060.00	42.11	54.00	-11.89	35.74	6.37	Average	100	59
6	12060.00	55.93	74.00	-18.07	49.56	6.37	Peak	100	59

Note 1: Emission Level (dBuV/m) = SA Reading (dBuV) + Factor* (dB/m)

*Factor includes antenna factor , cable loss and amplifier gain

Note 2: Margin (dB) = Emission level (dBuV/m) – Limit (dBuV/m).



Modulation	HT20	Test Freq. (MHz)	2412
Polarization	Vertical		

Test By :Akun Chung- Temperature(°C):24 Humidity(%):66

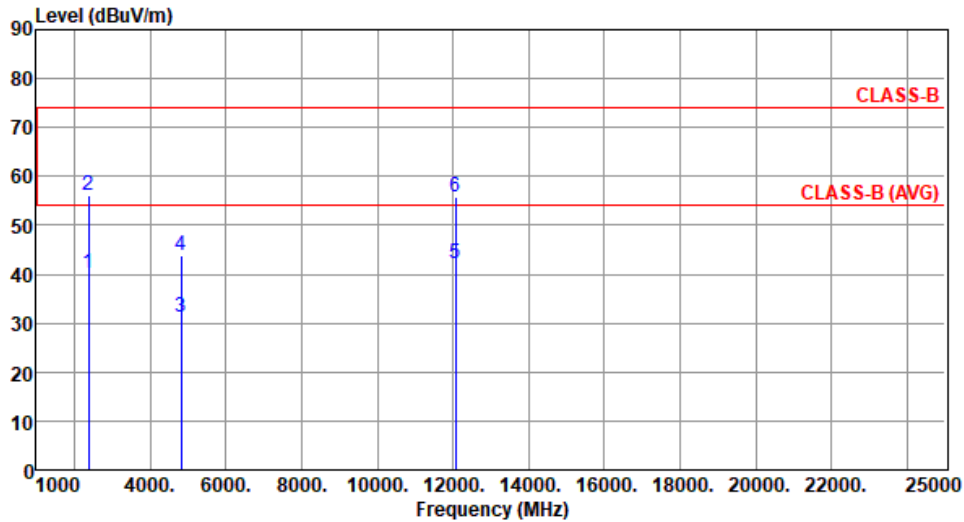

	Freq. MHz	Emission level dBUV/m	Limit dBUV/m	Margin dB	SA reading dBUV	Factor dB/m	Remark	ANT High cm	Turn Table deg
1	2390.00	40.27	54.00	-13.73	44.92	-4.65	Average	196	193
2	2390.00	56.04	74.00	-17.96	60.69	-4.65	Peak	196	193
3	4824.00	31.12	54.00	-22.88	31.65	-0.53	Average	100	176
4	4824.00	43.94	74.00	-30.06	44.47	-0.53	Peak	100	176
5	12060.00	42.29	54.00	-11.71	35.92	6.37	Average	100	37
6	12060.00	55.84	74.00	-18.16	49.47	6.37	Peak	100	37

Note 1: Emission Level (dBUV/m) = SA Reading (dBUV) + Factor* (dB/m)

*Factor includes antenna factor , cable loss and amplifier gain

Note 2: Margin (dB) = Emission level (dBUV/m) – Limit (dBUV/m).



Modulation	HT20	Test Freq. (MHz)	2437						
Polarization	Horizontal								
Test By : Akun Chung- Temperature(°C):24 Humidity(%):66									
	Freq.	Emission level	Limit	Margin	SA reading	Factor	Remark	ANT High	Turn Table
	MHz	dBuV/m	dBuV/m	dB	dBuV	dB/m		cm	deg
1	2390.00	36.93	54.00	-17.07	41.58	-4.65	Average	145	192
2	2390.00	48.72	74.00	-25.28	53.37	-4.65	Peak	145	192
3	2483.50	37.14	54.00	-16.86	42.03	-4.89	Average	145	192
4	2483.50	48.46	74.00	-25.54	53.35	-4.89	Peak	145	192
5	4874.00	31.24	54.00	-22.76	31.78	-0.54	Average	100	156
6	4874.00	44.37	74.00	-29.63	44.91	-0.54	Peak	100	156
7	7311.00	37.51	54.00	-16.49	32.29	5.22	Average	100	88
8	7311.00	50.83	74.00	-23.17	45.61	5.22	Peak	100	88

Note 1: Emission Level (dBuV/m) = SA Reading (dBuV) + Factor* (dB/m)
 *Factor includes antenna factor , cable loss and amplifier gain
 Note 2: Margin (dB) = Emission level (dBuV/m) – Limit (dBuV/m).



Modulation	HT20	Test Freq. (MHz)	2437
Polarization	Vertical		

Test By :Akun Chung- Temperature(°C):24 Humidity(%):66

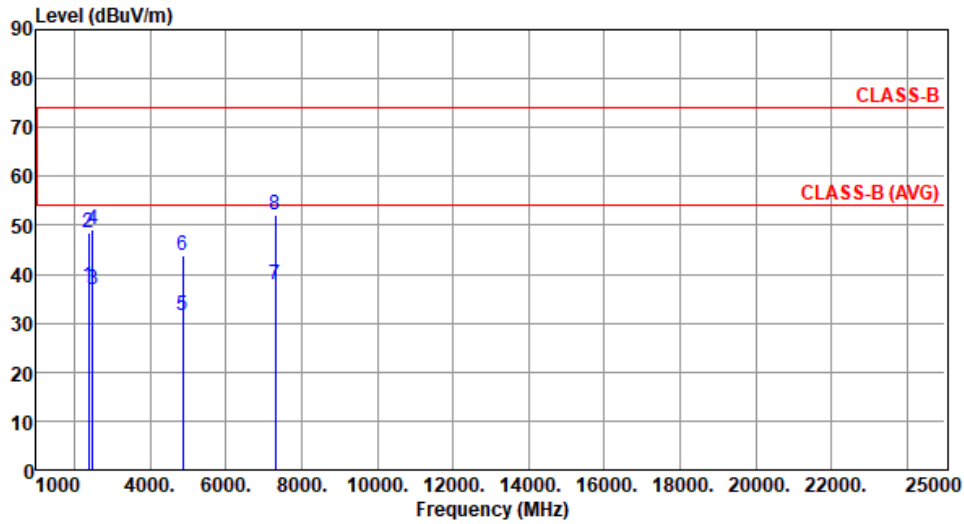

	Freq. MHz	Emission level dBuV/m	Limit dBuV/m	Margin dB	SA reading dBuV	Factor dB/m	Remark	ANT High cm	Turn Table deg
1	2390.00	37.38	54.00	-16.62	42.03	-4.65	Average	163	193
2	2390.00	48.49	74.00	-25.51	53.14	-4.65	Peak	163	193
3	2483.50	36.99	54.00	-17.01	41.88	-4.89	Average	163	193
4	2483.50	49.02	74.00	-24.98	53.91	-4.89	Peak	163	193
5	4874.00	31.44	54.00	-22.56	31.98	-0.54	Average	100	102
6	4874.00	43.99	74.00	-30.01	44.53	-0.54	Peak	100	102
7	7311.00	37.70	54.00	-16.30	32.48	5.22	Average	100	41
8	7311.00	52.23	74.00	-21.77	47.01	5.22	Peak	100	41

Note 1: Emission Level (dBuV/m) = SA Reading (dBuV) + Factor* (dB/m)

*Factor includes antenna factor , cable loss and amplifier gain

Note 2: Margin (dB) = Emission level (dBuV/m) – Limit (dBuV/m).



Modulation	HT20	Test Freq. (MHz)	2462
Polarization	Horizontal		

Test By : Akun Chung- Temperature(°C):24 Humidity(%):66

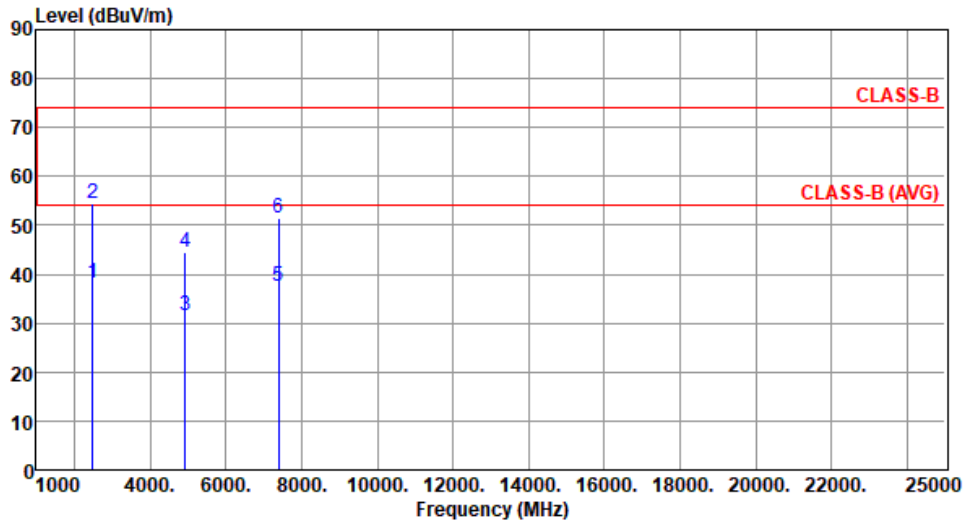

	Freq. MHz	Emission level dBuV/m	Limit dBuV/m	Margin dB	SA reading dBuV	Factor dB/m	Remark	ANT High cm	Turn Table deg
1	2483.50	38.29	54.00	-15.71	43.18	-4.89	Average	226	196
2	2483.50	54.57	74.00	-19.43	59.46	-4.89	Peak	226	196
3	4924.00	31.42	54.00	-22.58	31.93	-0.51	Average	100	122
4	4924.00	44.60	74.00	-29.40	45.11	-0.51	Peak	100	122
5	7386.00	37.44	54.00	-16.56	32.37	5.07	Average	100	73
6	7386.00	51.38	74.00	-22.62	46.31	5.07	Peak	100	73

Note 1: Emission Level (dBuV/m) = SA Reading (dBuV) + Factor* (dB/m)

*Factor includes antenna factor , cable loss and amplifier gain

Note 2: Margin (dB) = Emission level (dBuV/m) – Limit (dBuV/m).



Modulation	HT20	Test Freq. (MHz)	2462
Polarization	Vertical		

Test By :Akun Chung- Temperature(°C):24 Humidity(%):66

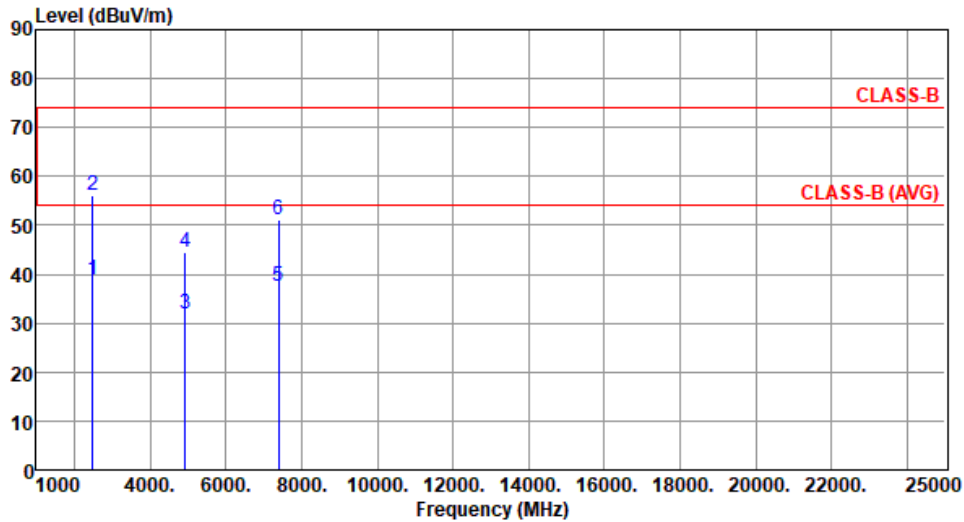

	Freq. MHz	Emission level dBuV/m	Limit dBuV/m	Margin dB	SA reading dBuV	Factor dB/m	Remark	ANT High cm	Turn Table deg
1	2483.50	38.82	54.00	-15.18	43.71	-4.89	Average	226	202
2	2483.50	56.23	74.00	-17.77	61.12	-4.89	Peak	226	202
3	4924.00	31.76	54.00	-22.24	32.27	-0.51	Average	100	118
4	4924.00	44.47	74.00	-29.53	44.98	-0.51	Peak	100	118
5	7386.00	37.50	54.00	-16.50	32.43	5.07	Average	100	41
6	7386.00	50.99	74.00	-23.01	45.92	5.07	Peak	100	41

Note 1: Emission Level (dBuV/m) = SA Reading (dBuV) + Factor* (dB/m)

*Factor includes antenna factor , cable loss and amplifier gain

Note 2: Margin (dB) = Emission level (dBuV/m) – Limit (dBuV/m).

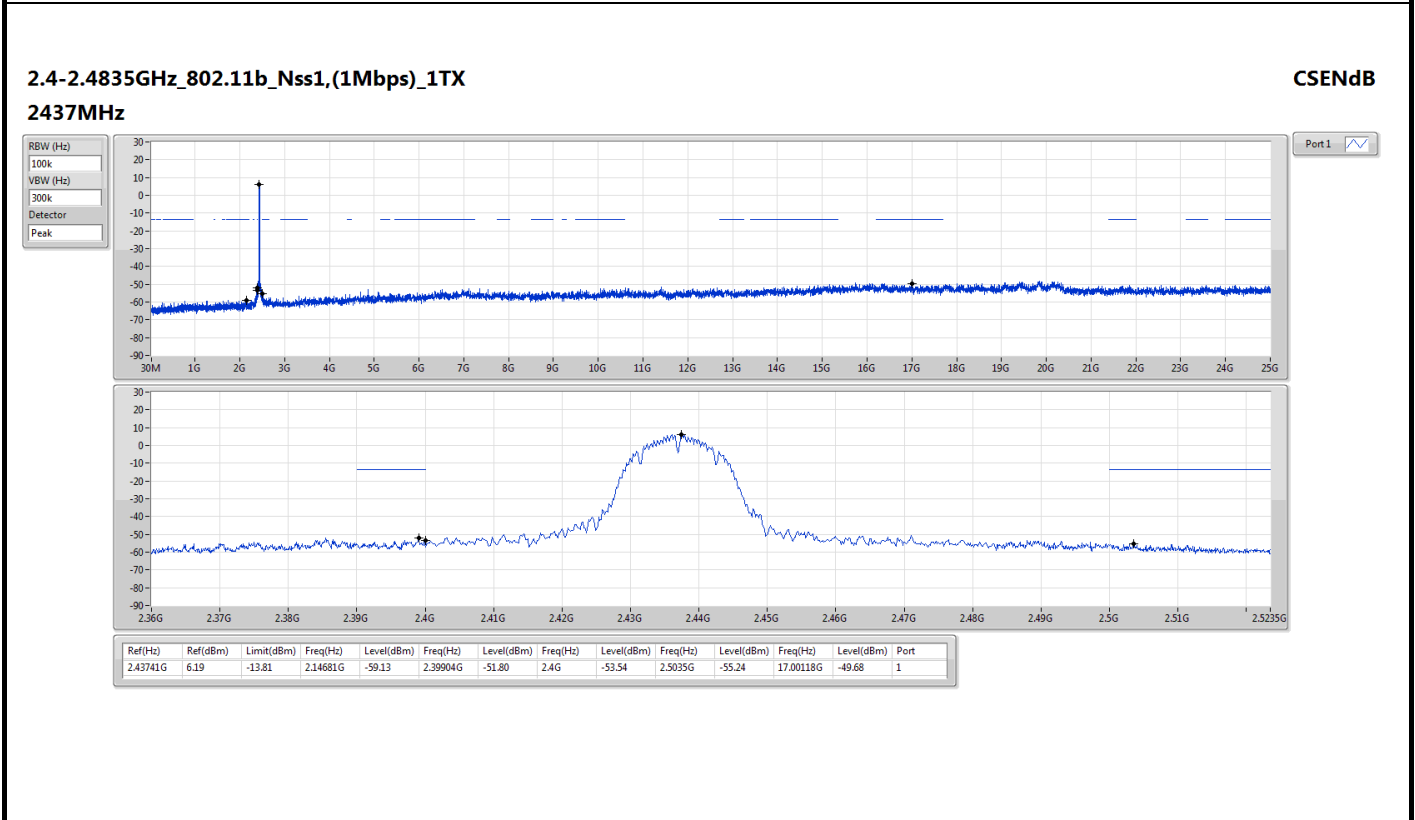
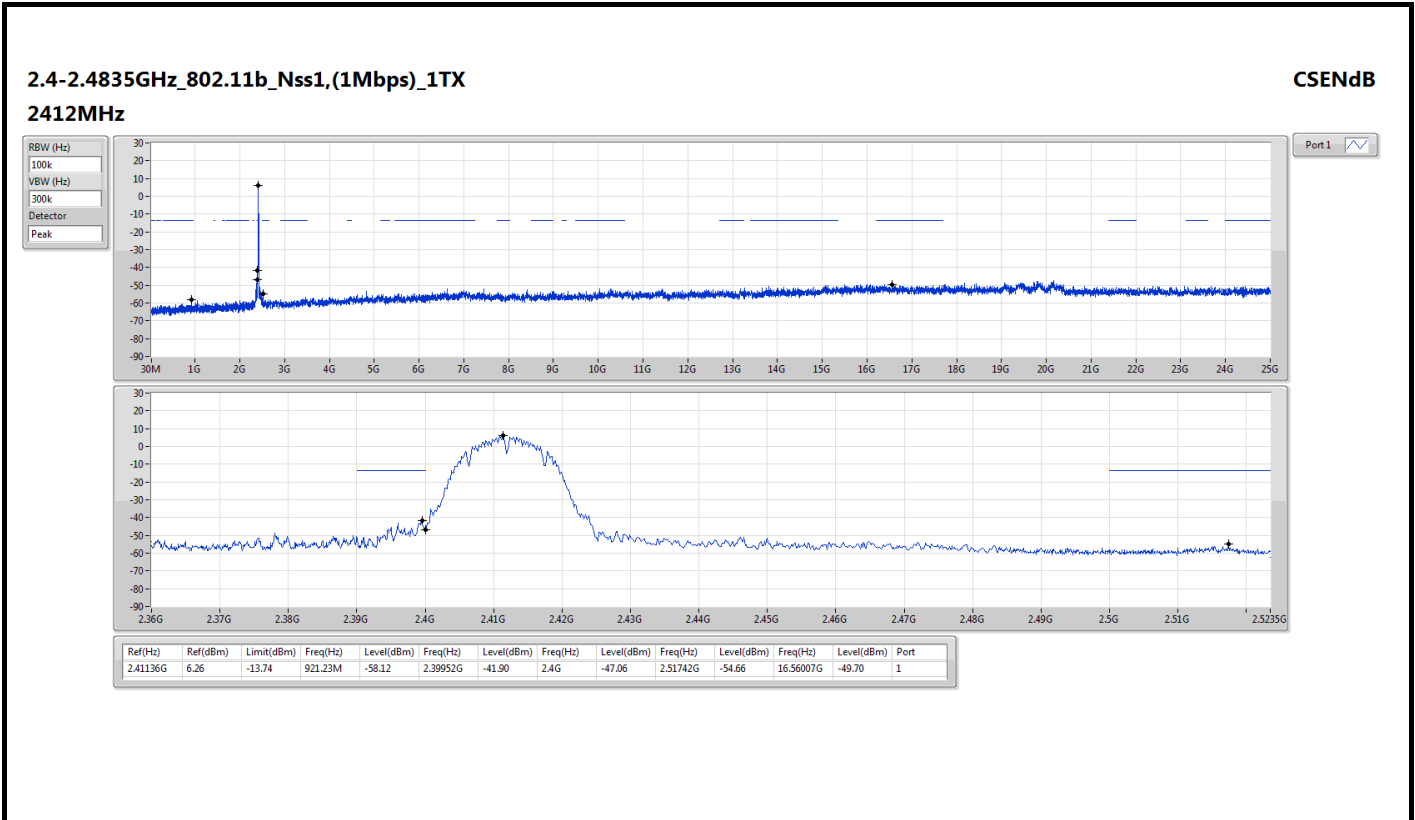



2.4-2.4835GHz_802.11b_Nss1,(1Mbps)_1TX
2462MHz

CSEndB

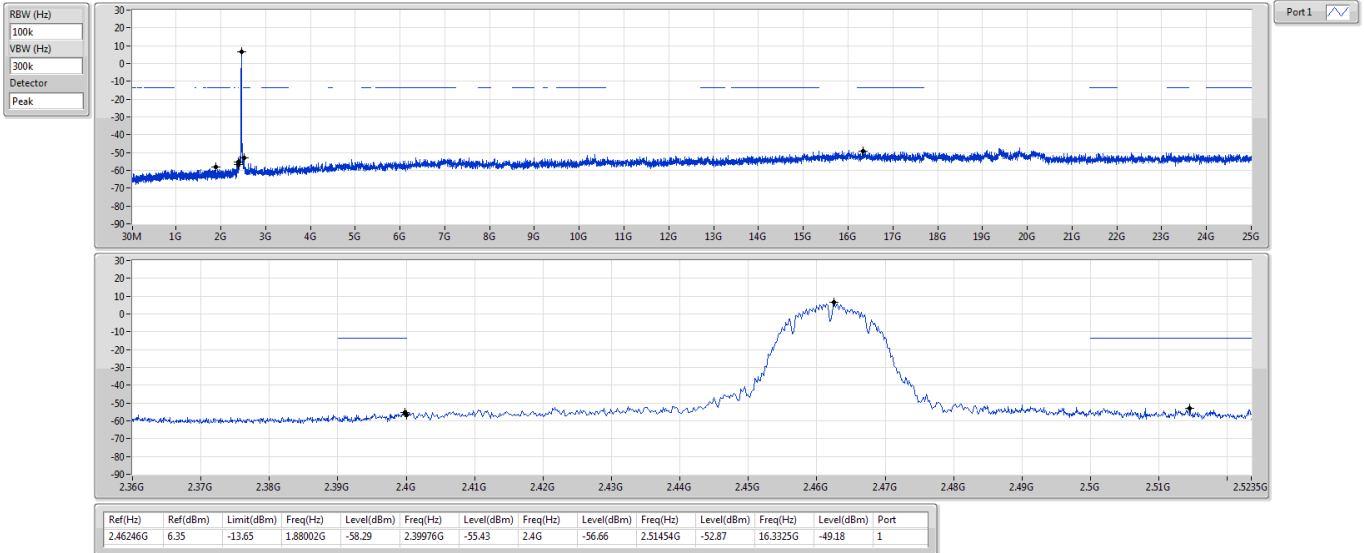

2.4-2.4835GHz_802.11g_Nss1,(6Mbps)_1TX
2412MHz

CSEndB

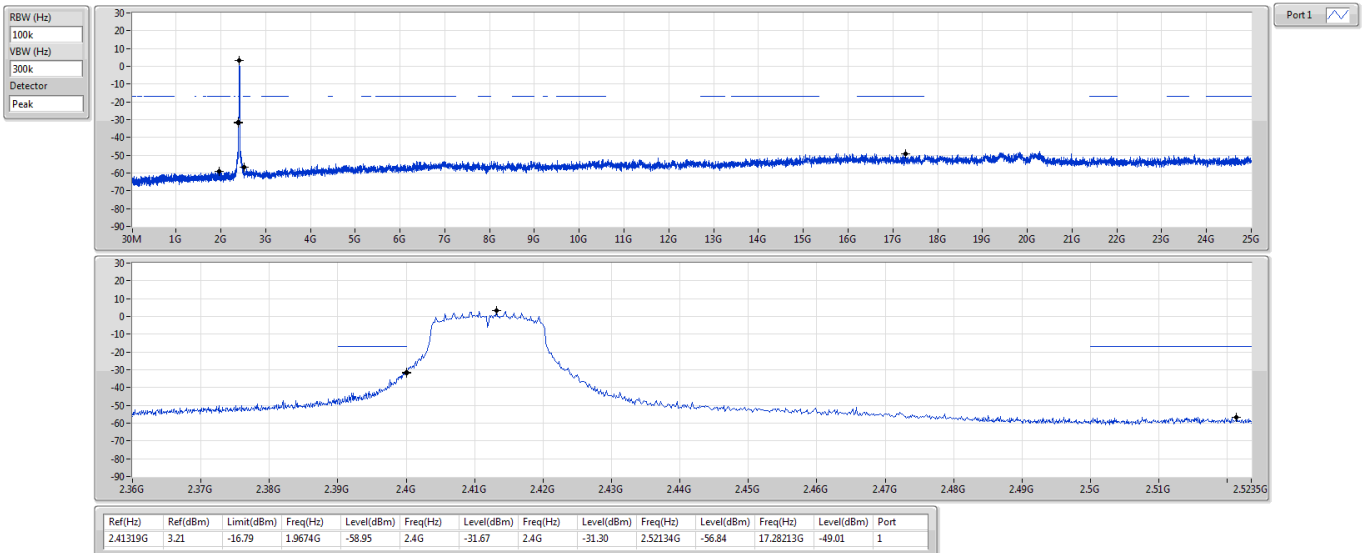



2.4-2.4835GHz_802.11g_Nss1,(6Mbps)_1TX
2437MHz

CSEndB

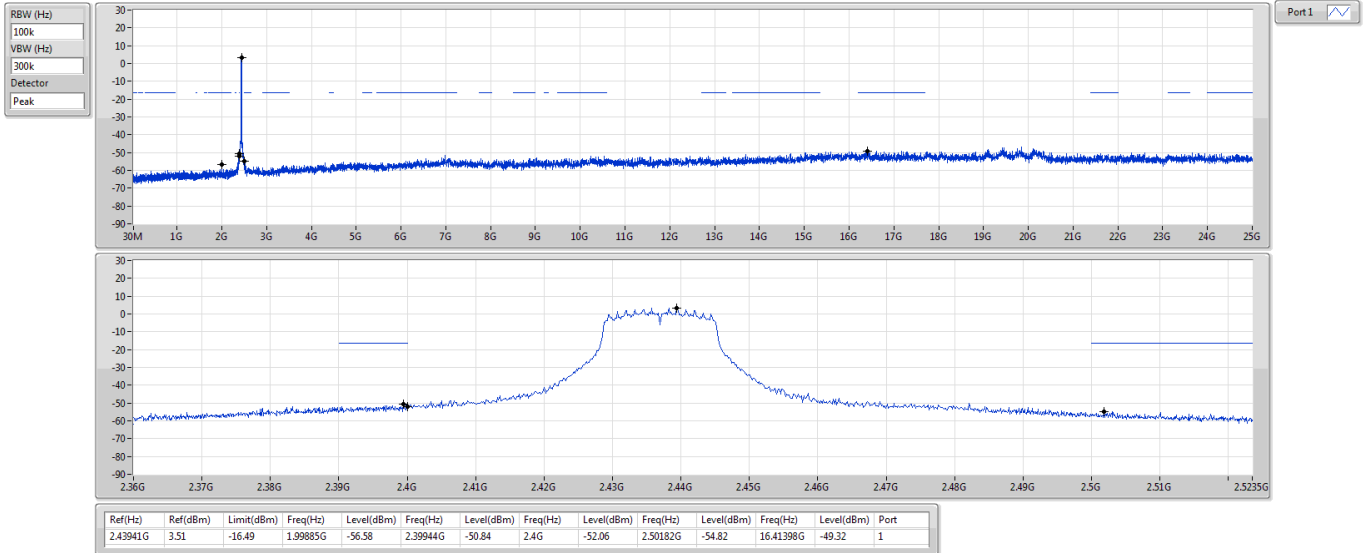

2.4-2.4835GHz_802.11g_Nss1,(6Mbps)_1TX
2462MHz

CSEndB

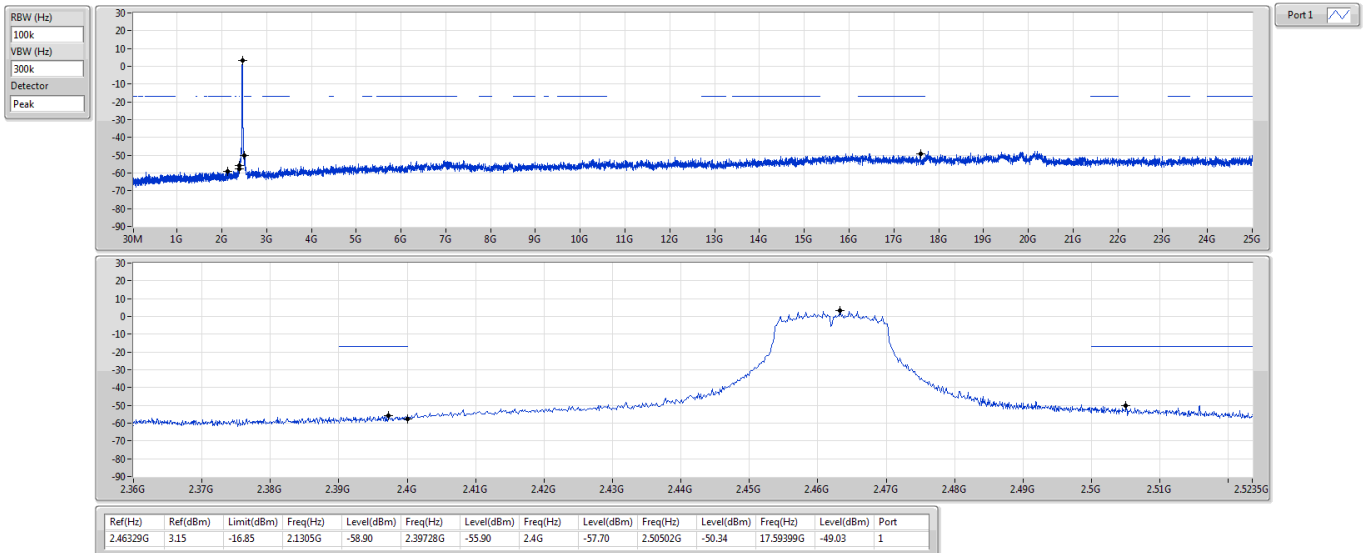



2.4-2.4835GHz_802.11n HT20_Nss1,(MCS0)_1TX
2412MHz

CSEndB

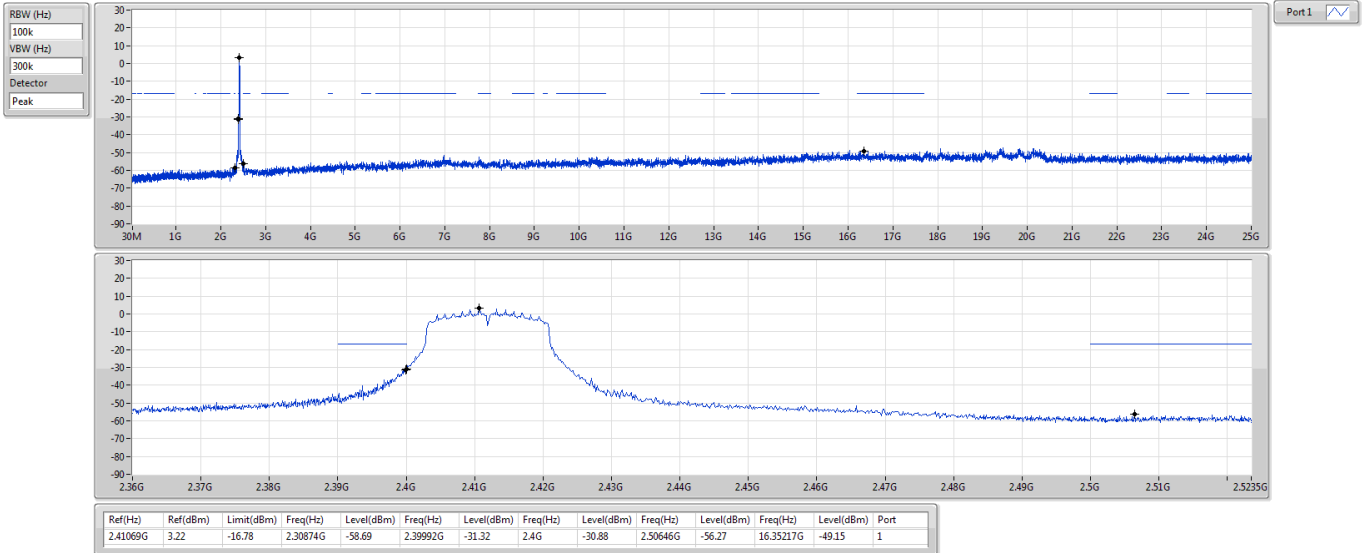

2.4-2.4835GHz_802.11n HT20_Nss1,(MCS0)_1TX
2437MHz

CSEndB

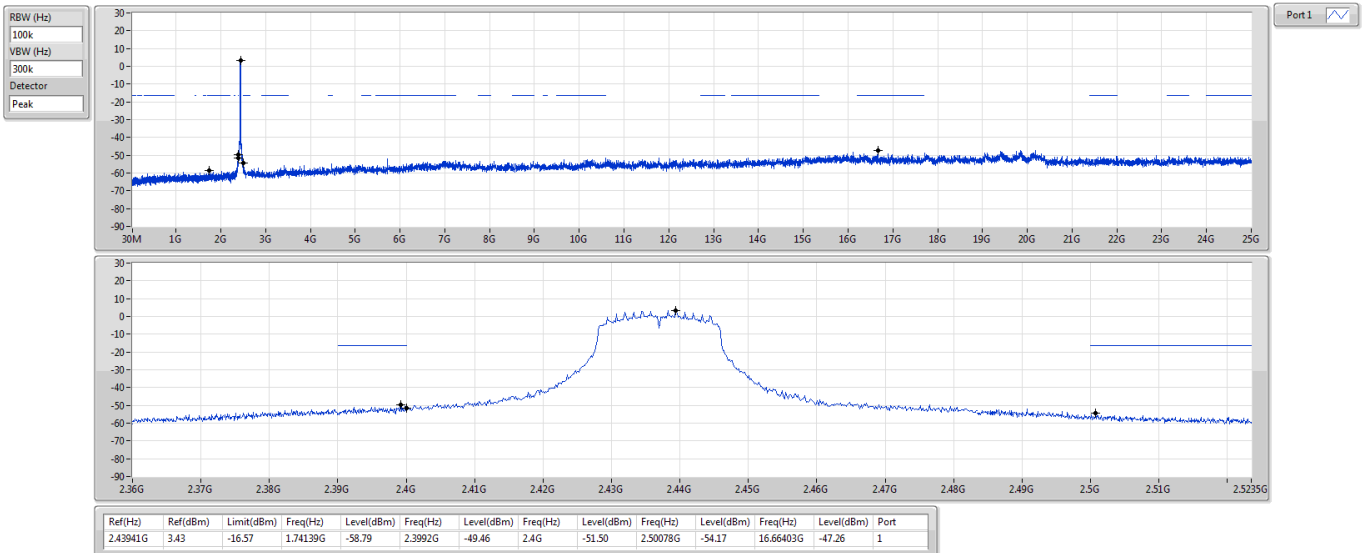



2.4-2.4835GHz_802.11n HT20_Nss1,(MCS0)_1TX
2462MHz

CSEndB

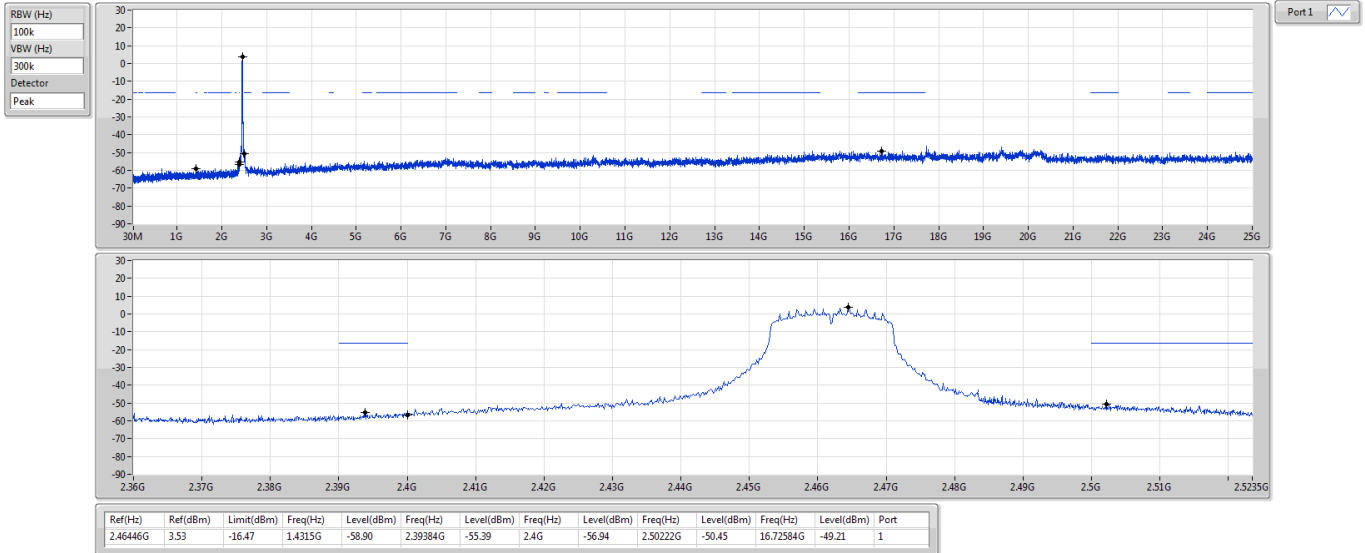



Modulation Mode	11g	Test Freq. (MHz)	2462
Power Phase	Line		

Test by : Joe Liao Temperature: 24°C Humidity: 60%

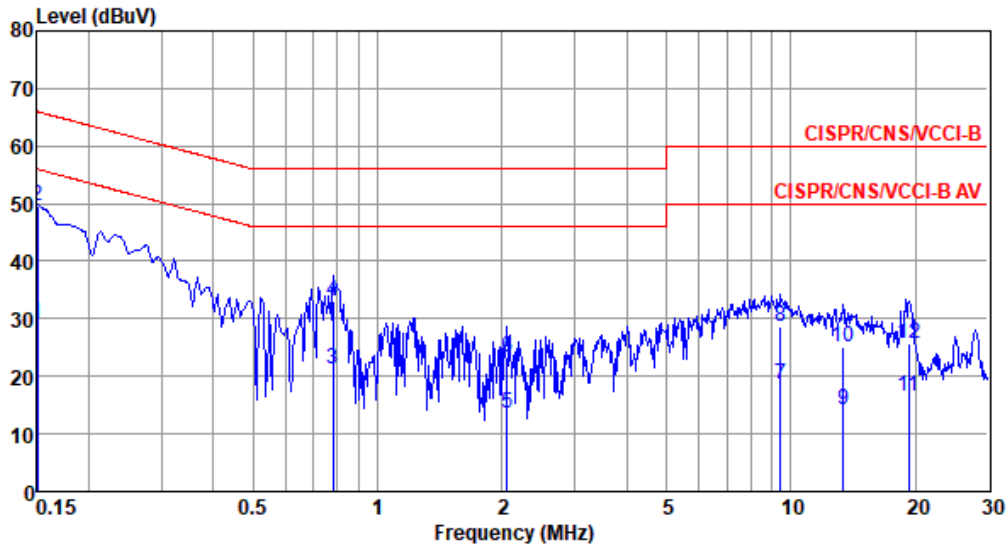

	Freq MHz	Level dBuV	Limit Line dBuV	Over Limit dB	Read Level dBuV	Factor dB	Cable loss dB	Aux dB	Remark
1	0.150	29.12	56.00	-26.88	19.20	9.68	0.06	0.18	Average
2*	0.150	49.61	66.00	-16.39	39.69	9.68	0.06	0.18	QP
3	0.779	21.13	46.00	-24.87	11.03	9.68	0.10	0.32	Average
4	0.779	33.16	56.00	-22.84	23.06	9.68	0.10	0.32	QP
5	2.055	13.63	46.00	-32.37	3.45	9.69	0.13	0.36	Average
6	2.055	23.37	56.00	-32.63	13.19	9.69	0.13	0.36	QP
7	9.451	18.72	50.00	-31.28	8.19	9.74	0.35	0.44	Average
8	9.451	28.66	60.00	-31.34	18.13	9.74	0.35	0.44	QP
9	13.408	14.22	50.00	-35.78	3.58	9.74	0.42	0.48	Average
10	13.408	24.97	60.00	-35.03	14.33	9.74	0.42	0.48	QP
11	19.326	16.53	50.00	-33.47	5.78	9.73	0.50	0.52	Average
12	19.326	25.82	60.00	-34.18	15.07	9.73	0.50	0.52	QP

Note 1: Level (dBuV) = Read Level (dBuV) + LISN Factor (dB) + Cable Loss (dB) + Aux (dB).
 Note 2: Over Limit (dB) = Level (dBuV) - Limit Line (dBuV).



Modulation Mode	11g	Test Freq. (MHz)	2462
Power Phase	Neutral		

Test by : Joe Liao Temperature: 24°C Humidity: 60%

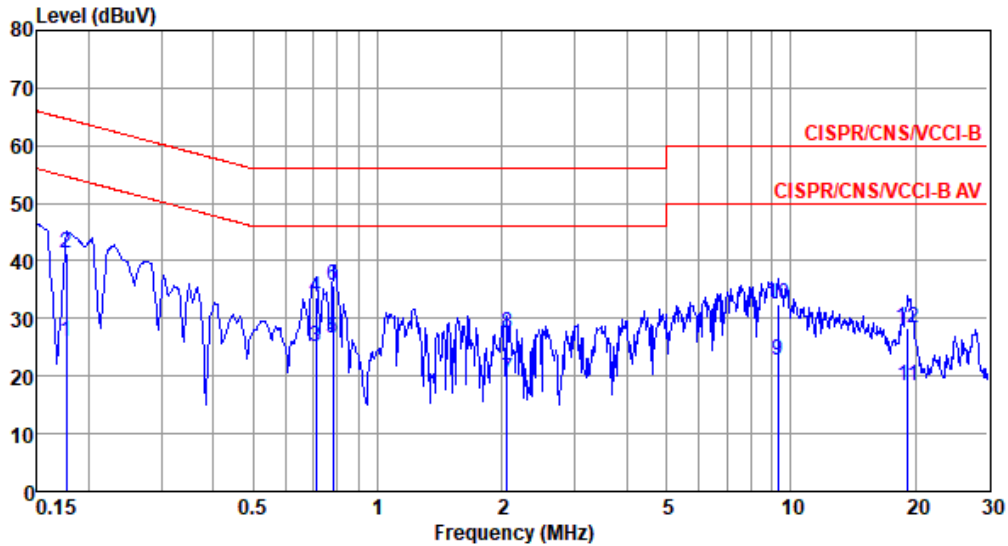

	Freq MHz	Level dBUV	Limit Line dBUV	Over Limit dB	Read Level dBUV	Factor dB	Cable loss dB	Aux dB	Remark
1	0.177	26.09	54.64	-28.55	16.23	9.61	0.06	0.19	Average
2	0.177	41.40	64.64	-23.24	31.54	9.61	0.06	0.19	QP
3	0.708	25.02	46.00	-20.98	15.00	9.61	0.09	0.32	Average
4	0.708	33.71	56.00	-22.29	23.69	9.61	0.09	0.32	QP
5*	0.779	26.57	46.00	-19.43	16.54	9.61	0.10	0.32	Average
6	0.779	35.74	56.00	-20.26	25.71	9.61	0.10	0.32	QP
7	2.055	19.54	46.00	-26.46	9.43	9.62	0.13	0.36	Average
8	2.055	27.38	56.00	-28.62	17.27	9.62	0.13	0.36	QP
9	9.302	22.63	50.00	-27.37	12.15	9.69	0.35	0.44	Average
10	9.302	32.48	60.00	-27.52	22.00	9.69	0.35	0.44	QP
11	19.224	18.31	50.00	-31.69	7.51	9.78	0.50	0.52	Average
12	19.224	28.24	60.00	-31.76	17.44	9.78	0.50	0.52	QP

Note 1: Level (dBUV) = Read Level (dBUV) + LISN Factor (dB) + Cable Loss (dB) + Aux (dB).
 2: Over Limit (dB) = Level (dBUV) – Limit Line (dBUV).