



FCC TEST REPORT

REPORT NO.: RF980619L05

MODEL NO.: WBS01

RECEIVED: Jun. 19, 2009

TESTED: Aug. 13 ~ Aug. 21, 2009

ISSUED: Aug. 24, 2009

APPLICANT: Withings

ADDRESS: 37bis, rue du General Leclerc -- 92442
Issy-les-Moulineaux Cedex, FRANCE

ISSUED BY: Bureau Veritas Consumer Products Services (H.K.)
Ltd., Taoyuan Branch

LAB ADDRESS: No. 47, 14th Ling, Chia Pau Tsuen, Lin Kou Hsiang,
Taipei Hsien 244, Taiwan, R.O.C.

TEST LOCATION: No. 19, Hwa Ya 2nd Rd, Wen Hwa Tsuen, Kwei
Shan Hsiang, Taoyuan Hsien 333, Taiwan, R.O.C.

This test report consists of 58 pages in total. It may be duplicated completely for legal use with the approval of the applicant. It should not be reproduced except in full, without the written approval of our laboratory. The client should not use it to claim product endorsement by TAF or any government agencies. The test results in the report only apply to the tested sample.





TABLE OF CONTENTS

1.	CERTIFICATION	4
2.	SUMMARY OF TEST RESULTS	5
2.1	MEASUREMENT UNCERTAINTY	5
3.	GENERAL INFORMATION	6
3.1	GENERAL DESCRIPTION OF EUT	6
3.2	DESCRIPTION OF TEST MODES	7
3.2.1	CONFIGURATION OF SYSTEM UNDER TEST	7
3.2.2	TEST MODE APPLICABILITY AND TESTED CHANNEL DETAIL	8
3.3	GENERAL DESCRIPTION OF APPLIED STANDARDS	10
3.4	DESCRIPTION OF SUPPORT UNITS	10
4.	TEST TYPES AND RESULTS	11
4.1	RADIATED EMISSION MEASUREMENT	11
4.1.1	LIMITS OF RADIATED EMISSION MEASUREMENT	11
4.1.2	TEST INSTRUMENTS	12
4.1.3	TEST PROCEDURES	13
4.1.4	DEVIATION FROM TEST STANDARD	13
4.1.5	TEST SETUP	14
4.1.6	EUT OPERATING CONDITIONS	14
4.1.7	TEST RESULTS	15
4.2	6dB BANDWIDTH MEASUREMENT	29
4.2.1	LIMITS OF 6dB BANDWIDTH MEASUREMENT	29
4.2.2	TEST INSTRUMENTS	29
4.2.3	TEST PROCEDURE	29
4.2.4	DEVIATION FROM TEST STANDARD	29
4.2.5	TEST SETUP	30
4.2.6	EUT OPERATING CONDITIONS	30
4.2.7	TEST RESULTS	31
4.3	MAXIMUM PEAK OUTPUT POWER	35
4.3.1	LIMITS OF MAXIMUM PEAK OUTPUT POWER MEASUREMENT	35
4.3.2	INSTRUMENTS	35
4.4.3	TEST PROCEDURES	35
4.4.4	DEVIATION FROM TEST STANDARD	35
4.4.5	TEST SETUP	36
4.4.6	EUT OPERATING CONDITIONS	36
4.4.7	TEST RESULTS	37



4.4	POWER SPECTRAL DENSITY MEASUREMENT.....	38
4.4.1	LIMITS OF POWER SPECTRAL DENSITY MEASUREMENT	38
4.4.2	TEST INSTRUMENTS.....	38
4.4.3	TEST PROCEDURE	38
4.4.4	DEVIATION FROM TEST STANDARD.....	38
4.4.5	TEST SETUP	39
4.4.6	EUT OPERATING CONDITION.....	39
4.4.7	TEST RESULTS	40
4.5	BAND EDGES MEASUREMENT	44
4.5.1	LIMITS OF BAND EDGES MEASUREMENT	44
4.5.2	TEST INSTRUMENTS.....	44
4.5.3	TEST PROCEDURE	44
4.5.4	DEVIATION FROM TEST STANDARD.....	44
4.5.5	EUT OPERATING CONDITION.....	44
4.5.6	TEST RESULTS	45
4.6	ANTENNA REQUIREMENT	55
4.6.1	STANDARD APPLICABLE	55
4.6.2	ANTENNA CONNECTED CONSTRUCTION.....	55
5.	PHOTOGRAPHS OF THE TEST CONFIGURATION.....	56
6.	INFORMATION ON THE TESTING LABORATORIES	57
7.	APPENDIX A - MODIFICATIONS RECORDERS FOR ENGINEERING CHANGES TO THE EUT BY THE LAB.....	58



1. CERTIFICATION

PRODUCT: Wireless Body Scale
MODEL: WBS01
BRAND: Withings
APPLICANT: Withings
TESTED: Aug. 13 ~ Aug. 21, 2009
TEST SAMPLE: ENGINEERING SAMPLE
STANDARDS: **FCC Part 15, Subpart C (Section 15.247)**
ANSI C63.4-2003

The above equipment (model: WBS01) has been tested by **Bureau Veritas Consumer Products Services (H.K.) Ltd., Taoyuan Branch**, and found compliance with the requirement of the above standards. The test record, data evaluation & Equipment Under Test (EUT) configurations represented herein are true and accurate accounts of the measurements of the sample's EMC characteristics under the conditions specified in this report.

PREPARED BY : Suntee Liu , **DATE :** Aug. 24, 2009
Suntee Liu / Specialist

TECHNICAL ACCEPTANCE : Long Chen , **DATE :** Aug. 24, 2009
Responsible for RF Long Chen / Senior Engineer

APPROVED BY : Gary Chang , **DATE :** Aug. 24, 2009
Gary Chang / Assistant Manager

2. SUMMARY OF TEST RESULTS

The EUT has been tested according to the following specifications:

APPLIED STANDARD: FCC Part 15, Subpart C			
Standard Section	Test Type and Limit	Result	Remark
15.207	AC Power Conducted Emission	NA	Power supply is 6Vdc from battery
15.247(a)(2)	Spectrum Bandwidth of a Direct Sequence Spread Spectrum System Limit: min. 500kHz	PASS	Meet the requirement of limit.
15.247(b)	Maximum Peak Output Power Limit: max. 30dBm	PASS	Meet the requirement of limit.
15.247(d)	Radiated Emissions Limit: Table 15.209	PASS	Meet the requirement of limit. Minimum passing margin is -1.25dB at 2483.50MHz.
15.247(e)	Power Spectral Density Limit: max. 8dBm	PASS	Meet the requirement of limit.
15.247(d)	Band Edge Measurement Limit: 20dB less than the peak value of fundamental frequency	PASS	Meet the requirement of limit.

2.1 MEASUREMENT UNCERTAINTY

Where relevant, the following measurement uncertainty levels have been estimated for tests performed on the EUT as specified in CISPR 16-4-2:

MEASUREMENT	FREQUENCY	UNCERTAINTY
Radiated emissions	30MHz ~ 200MHz	2.93 dB
	200MHz ~ 1000MHz	2.95 dB
	1GHz ~ 18GHz	2.26 dB
	18GHz ~ 40GHz	1.94 dB

This uncertainty represents an expanded uncertainty expressed at approximately the 95% confidence level using a coverage factor of k=2.

3. GENERAL INFORMATION

3.1 GENERAL DESCRIPTION OF EUT

PRODUCT	Wireless Body Scale
MODEL NO.	WBS01
FCC ID	XNAWBS01
POWER SUPPLY	6 Vdc from battery
MODULATION TYPE	CCK, DQPSK, DBPSK for DSSS 64QAM, 16QAM, QPSK, BPSK for OFDM
MODULATION TECHNOLOGY	DSSS, OFDM
TRANSFER RATE	802.11b: 11.0/ 5.5/ 2.0/ 1.0Mbps 802.11g: 54.0/ 48.0/ 36.0/ 24.0/ 18.0/ 12.0/ 9.0/ 6.0Mbps
OPERATING FREQUENCY	2412MHz ~ 2462MHz
NUMBER OF CHANNEL	11
MAXIMUM OUTPUT POWER	193.64mW
ANTENNA TYPE	PIFA antenna with 1.89dBi gain Printed antenna with -0.21dBi gain
DATA CABLE	1.5 m shielded USB cable without core
I/O PORTS	Refer to user's manual
ACCESSORY DEVICES	NA

NOTE:

1. The EUT, operates in the 2.4GHz frequency range, lets you connect IEEE 802.11g or IEEE 802.11b devices to the network. With its high-speed data transmissions up to 54Mbps.
2. The above EUT information was declared by manufacturer and for more detailed features description, please refer to the manufacturer's specifications or user's manual.

3.2 DESCRIPTION OF TEST MODES

Eleven channels are provided to this EUT:

CHANNEL	FREQUENCY	CHANNEL	FREQUENCY
1	2412MHz	7	2442MHz
2	2417MHz	8	2447MHz
3	2422MHz	9	2452MHz
4	2427MHz	10	2457MHz
5	2432MHz	11	2462MHz
6	2437MHz		

3.2.1 CONFIGURATION OF SYSTEM UNDER TEST

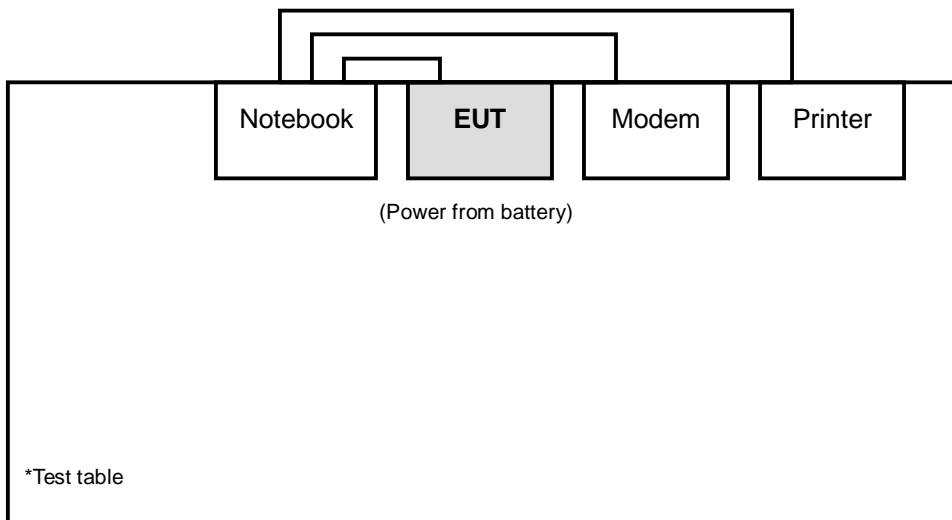

NOTE: The USB cable is used to set configuration of EUT only. Charging function is not supported for the EUT.

3.2.2 TEST MODE APPLICABILITY AND TESTED CHANNEL DETAIL

EUT CONFIGURE MODE	APPLICABLE TO				DESCRIPTION
	RE ³ 1G	RE<1G	PLC	APCM	
A	√	√	NOTE 1	-	Printed antenna
B	√	√	NOTE 1	√	PIFA antenna

Where **PLC**: Power Line Conducted Emission **RE<1G**: Radiated Emission below 1GHz
RE³1G: Radiated Emission above 1GHz **APCM**: Antenna Port Conducted Measurement

NOTE 1: No need to concern of Conducted Emission due to the EUT is powered by battery.

NOTE 2: "-" means no effect

RADIATED EMISSION TEST (ABOVE 1 GHz):

- Pre-Scan has been conducted to determine the worst-case mode from all possible combinations between available modulations, data rates, XYZ axis and antenna ports (if EUT with antenna diversity architecture).
- Following channel(s) was (were) selected for the final test as listed below.

EUT CONFIGURE MODE	MODE	AVAILABLE CHANNEL	TESTED CHANNEL	MODULATION TECHNOLOGY	MODULATION TYPE	DATA RATE (Mbps)
A, B	802.11b	1 to 11	1, 6, 11	DSSS	DBPSK	1
A, B	802.11g	1 to 11	1, 6, 11	OFDM	BPSK	6

RADIATED EMISSION TEST (BELOW 1 GHz):

- Pre-Scan has been conducted to determine the worst-case mode from all possible combinations between available modulations, data rates, XYZ axis and antenna ports (if EUT with antenna diversity architecture).
- Following channel(s) was (were) selected for the final test as listed below.

EUT CONFIGURE MODE	MODE	AVAILABLE CHANNEL	TESTED CHANNEL	MODULATION TECHNOLOGY	MODULATION TYPE	DATA RATE (Mbps)
A, B	802.11g	1 to 11	6	OFDM	BPSK	6

BANDEDGE MEASUREMENT:

- Pre-Scan has been conducted to determine the worst-case mode from all possible combinations between available modulations, data rates, and antenna ports (if EUT with antenna diversity architecture).
- Following channel(s) was (were) selected for the final test as listed below.

EUT CONFIGURE MODE	MODE	AVAILABLE CHANNEL	TESTED CHANNEL	MODULATION TECHNOLOGY	MODULATION TYPE	DATA RATE (Mbps)
A, B	802.11b	1 to 11	1, 11	DSSS	DBPSK	1
A, B	802.11g	1 to 11	1, 11	OFDM	BPSK	6

ANTENNA PORT CONDUCTED MEASUREMENT:

- Pre-Scan has been conducted to determine the worst-case mode from all possible combinations between available modulations, data rates, and antenna ports (if EUT with antenna diversity architecture).
- Following channel(s) was (were) selected for the final test as listed below.

EUT CONFIGURE MODE	MODE	AVAILABLE CHANNEL	TESTED CHANNEL	MODULATION TECHNOLOGY	MODULATION TYPE	DATA RATE (Mbps)
A	802.11b	1 to 11	1, 6, 11	DSSS	DBPSK	1
A	802.11g	1 to 11	1, 6, 11	OFDM	BPSK	6

3.3 GENERAL DESCRIPTION OF APPLIED STANDARDS

The EUT is a RF product. According to the specifications of the manufacturer, it must comply with the requirements of the following standards:

FCC Part 15, Subpart C (15.247)

ANSI C63.4-2003

All test items have been performed and recorded as per the above standards.

NOTE: The EUT is also considered as a kind of computer peripheral, because the connection to computer is necessary for typical use. It has been verified to comply with the requirements of FCC Part 15, Subpart B, Class B (DoC). The test report has been issued separately.

3.4 DESCRIPTION OF SUPPORT UNITS

The EUT has been tested as an independent unit together with other necessary accessories or support units. The following support units or accessories were used to form a representative test configuration during the tests.

NO.	PRODUCT	BRAND	MODEL NO.	SERIAL NO.	FCC ID
1	NOTEBOOK COMPUTER	DELL	PP05L	12130898320	E2K24CLNS
2	MODEM	ACEEX	1414V/3	0401008253	IFAXDM1414
3	PRINTER	EPSON	LQ-300+	DCGY054011	FCC DoC Approved

NO.	SIGNAL CABLE DESCRIPTION OF THE ABOVE SUPPORT UNITS
1	NA
2	1.2 m braid shielded wire, DB25 & DB9 connector, w/o core
3	1.8 m braid shielded wire, DB25 connector, w/o core

NOTE: All power cords of the above support units are non-shielded (1.8 m).

4. TEST TYPES AND RESULTS

4.1 RADIATED EMISSION MEASUREMENT

4.1.1 LIMITS OF RADIATED EMISSION MEASUREMENT

Emissions radiated outside of the specified bands, shall be according to the general radiated limits in 15.209 as following:

FREQUENCIES (MHz)	FIELD STRENGTH (microvolts/meter)	MEASUREMENT DISTANCE (meters)
0.009 ~ 0.490	2400 / F(kHz)	300
0.490 ~ 1.705	24000 / F(kHz)	30
1.705 ~ 30.0	30	30
30 ~ 88	100	3
88 ~ 216	150	3
216 ~ 960	200	3
Above 960	500	3

NOTE:

1. The lower limit shall apply at the transition frequencies.
2. Emission level (dBuV/m) = 20 log Emission level (uV/m).
3. As shown in 15.35(b), for frequencies above 1000MHz, the field strength limits are based on average detector, however, the peak field strength of any emission shall not exceed the maximum permitted average limits, specified above by more than 20dB under any condition of modulation.

4.1.2 TEST INSTRUMENTS

DESCRIPTION & MANUFACTURER	MODEL NO.	SERIAL NO.	DATE OF CALIBRATION	DUE DATE OF CALIBRATION
Test Receiver ROHDE & SCHWARZ	ESIB7	100212	May 25, 2009	May 24, 2010
Spectrum Analyzer ROHDE & SCHWARZ	FSP40	100040	Jul. 07, 2009	Jul. 06, 2010
BILOG Antenna SCHWARZBECK	VULB9168	9168-156	Apr. 30, 2009	Apr. 29, 2010
HORN Antenna SCHWARZBECK	BBHA 9120 D	9120D-563	Aug. 10, 2009	Aug. 09, 2010
HORN Antenna SCHWARZBECK	BBHA 9170	BBHA9170242	Jan. 06, 2009	Jan. 05, 2010
Preamplifier Agilent	8449B	3008A01911	Sep. 10, 2008	Sep. 09, 2009
Preamplifier Agilent	8447D	2944A10638	Dec. 26, 2008	Dec. 25, 2009
RF signal cable HUBER+SUHNNER	SUCOFLEX 104	218190/4 231241/4	May 13, 2009	May 12, 2010
RF signal cable Worken	8D-FB	Cable-HYCH9-01	Aug. 17, 2009	Aug. 16, 2010
Software	ADT_Radiated_ V7.6.15.9.2	NA	NA	NA
Antenna Tower EMCO	2070/2080	512.835.4684	NA	NA
Turn Table EMCO	2087-2.03	NA	NA	NA
Antenna Tower & Turn Table Controller EMCO	2090	NA	NA	NA

- NOTE:**
1. The calibration interval of the above test instruments is 12 months and the calibrations are traceable to NML/ROC and NIST/USA.
 2. The test was performed in HwaYa Chamber 9.
 3. The horn antenna and HP preamplifier (model: 8449B) are used only for the measurement of emission frequency above 1GHz if tested.
 4. The FCC Site Registration No. is 460141.
 5. The IC Site Registration No. is IC 7450F-4.

4.1.3 TEST PROCEDURES

- a. The EUT was placed on the top of a rotating table 0.8 meters above the ground at a 3 meters semi-anechoic chamber. The table was rotated 360 degrees to determine the position of the highest radiation.
- b. The EUT was set 3 meters away from the interference-receiving antenna, which was mounted on the top of a variable-height antenna tower.
- c. The antenna is a broadband antenna, and its height is varied from one meter to four meters above the ground to determine the maximum value of the field strength. Both horizontal and vertical polarizations of the antenna are set to make the measurement.
- d. For each suspected emission, the EUT was arranged to its worst case and then the antenna was tuned to heights from 1 meter to 4 meters and the rotatable table was turned from 0 degrees to 360 degrees to find the maximum reading.
- e. The test-receiver system was set to Peak Detect Function and Specified Bandwidth with Maximum Hold Mode.
- f. If the emission level of the EUT in peak mode was lower than the limit specified, then testing could be stopped and the peak values of the EUT would be reported. Otherwise the emissions would be re-tested one by one using peak, quasi-peak or average method as specified and then reported in a data sheet.

NOTE:

1. The resolution bandwidth and video bandwidth of test receiver/spectrum analyzer is 120kHz for Peak detection (PK) and Quasi-peak detection (QP) at frequency below 1GHz.
2. The resolution bandwidth of test receiver/spectrum analyzer is 1 MHz and video bandwidth is 3MHz for Peak detection at frequency above 1GHz.
3. The resolution bandwidth of test receiver/spectrum analyzer is 1MHz and the video bandwidth is 10Hz for Average detection (AV) at frequency above 1GHz.
4. All modes of operation were investigated and the worst-case emissions are reported.

4.1.4 DEVIATION FROM TEST STANDARD

No deviation.

4.1.5 TEST SETUP

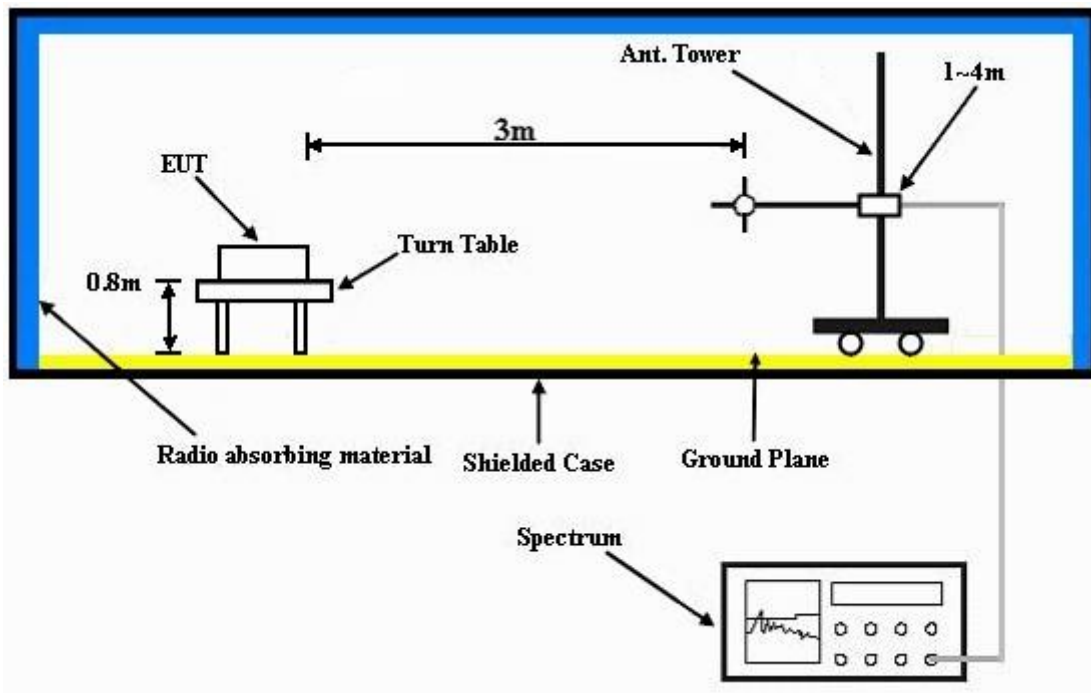

For the actual test configuration, please refer to the attached file (Test Setup Photo)

4.1.6 EUT OPERATING CONDITIONS

Placed the EUT on the testing table and set it under transmission condition continuously at specific channel frequency.

4.1.7 TEST RESULTS

802.11b DSSS MODULATION

EUT TEST CONDITION		MEASUREMENT DETAIL	
CHANNEL	Channel 1	FREQUENCY RANGE	1 ~ 25GHz
INPUT POWER	6 Vdc	DETECTOR FUNCTION	Peak (PK) Average (AV)
ENVIRONMENTAL CONDITIONS	23deg. C, 70%RH 980 hPa	TESTED BY	Lori Chiu
TEST MODE	A		

ANTENNA POLARITY & TEST DISTANCE: HORIZONTAL AT 3 M								
NO.	FREQ. (MHz)	EMISSION LEVEL (dBuV/m)	LIMIT (dBuV/m)	MARGIN (dB)	ANTENNA HEIGHT (m)	TABLE ANGLE (Degree)	RAW VALUE (dBuV)	CORRECTION FACTOR (dB/m)
1	2390.00	58.86 PK	74.00	-15.14	1.35 H	278	26.64	32.22
2	2390.00	48.15 AV	54.00	-5.85	1.35 H	278	15.93	32.22
3	*2412.00	108.68 PK			1.35 H	278	76.38	32.30
4	*2412.00	104.97 AV			1.35 H	278	72.67	32.30
5	4824.00	51.09 PK	74.00	-22.91	1.10 H	269	12.76	38.33
6	4824.00	43.90 AV	54.00	-10.10	1.10 H	269	5.57	38.33
7	#7236.00	53.20 PK	88.68	-35.48	1.12 H	42	8.75	44.45
8	#7236.00	41.64 AV	84.97	-43.33	1.12 H	42	-2.81	44.45

ANTENNA POLARITY & TEST DISTANCE: VERTICAL AT 3 M								
NO.	FREQ. (MHz)	EMISSION LEVEL (dBuV/m)	LIMIT (dBuV/m)	MARGIN (dB)	ANTENNA HEIGHT (m)	TABLE ANGLE (Degree)	RAW VALUE (dBuV)	CORRECTION FACTOR (dB/m)
1	2390.00	56.86 PK	74.00	-17.14	1.00 V	355	24.64	32.22
2	2390.00	46.37 AV	54.00	-7.63	1.00 V	355	14.15	32.22
3	*2412.00	100.84 PK			1.00 V	355	68.54	32.30
4	*2412.00	96.61 AV			1.00 V	355	64.31	32.30
5	4824.00	50.42 PK	74.00	-23.58	1.00 V	194	12.09	38.33
6	4824.00	44.71 AV	54.00	-9.29	1.00 V	194	6.38	38.33
7	#7236.00	53.57 PK	80.84	-27.27	1.01 V	189	9.12	44.45
8	#7236.00	41.19 AV	76.61	-35.42	1.01 V	189	-3.26	44.45

- REMARKS:**
1. Emission level (dBuV/m) = Raw Value (dBuV) + Correction Factor (dB/m).
 2. Correction Factor (dB/m) = Antenna Factor (dB/m) + Cable Factor (dB).
 3. The other emission levels were very low against the limit.
 4. Margin value = Emission level – Limit value.
 5. “ * “: Fundamental frequency.
 6. “#”:The radiated frequency is out the restricted band.



EUT TEST CONDITION		MEASUREMENT DETAIL	
CHANNEL	Channel 6	FREQUENCY RANGE	1 ~ 25GHz
INPUT POWER	6 Vdc	DETECTOR FUNCTION	Peak (PK) Average (AV)
ENVIRONMENTAL CONDITIONS	23deg. C, 70%RH 980 hPa	TESTED BY	Lori Chiu
TEST MODE	A		

ANTENNA POLARITY & TEST DISTANCE: HORIZONTAL AT 3 M								
NO.	FREQ. (MHz)	EMISSION LEVEL (dBuV/m)	LIMIT (dBuV/m)	MARGIN (dB)	ANTENNA HEIGHT (m)	TABLE ANGLE (Degree)	RAW VALUE (dBuV)	CORRECTION FACTOR (dB/m)
1	*2437.00	107.77 PK			1.28 H	274	75.38	32.39
2	*2437.00	103.49 AV			1.28 H	274	71.10	32.39
3	4874.00	49.96 PK	74.00	-24.04	1.02 H	38	11.55	38.41
4	4874.00	39.22 AV	54.00	-14.78	1.02 H	38	0.81	38.41
5	7311.00	51.78 PK	74.00	-22.22	1.01 H	1	7.15	44.64
6	7311.00	39.76 AV	54.00	-14.24	1.01 H	1	-4.87	44.64
ANTENNA POLARITY & TEST DISTANCE: VERTICAL AT 3 M								
NO.	FREQ. (MHz)	EMISSION LEVEL (dBuV/m)	LIMIT (dBuV/m)	MARGIN (dB)	ANTENNA HEIGHT (m)	TABLE ANGLE (Degree)	RAW VALUE (dBuV)	CORRECTION FACTOR (dB/m)
1	*2437.00	99.08 PK			1.14 V	187	66.69	32.39
2	*2437.00	95.19 AV			1.14 V	187	62.80	32.39
3	4874.00	49.70 PK	74.00	-24.30	1.00 V	265	11.29	38.41
4	4874.00	42.40 AV	54.00	-11.60	1.00 V	265	3.99	38.41
5	7311.00	53.01 PK	74.00	-20.99	1.15 V	5	8.38	44.64
6	7311.00	41.83 AV	54.00	-12.17	1.15 V	5	-2.80	44.64

- REMARKS:**
1. Emission level (dBuV/m) = Raw Value (dBuV) + Correction Factor (dB/m).
 2. Correction Factor (dB/m) = Antenna Factor (dB/m) + Cable Factor (dB).
 3. The other emission levels were very low against the limit.
 4. Margin value = Emission level – Limit value.
 5. “ * ”: Fundamental frequency.

EUT TEST CONDITION		MEASUREMENT DETAIL	
CHANNEL	Channel 11	FREQUENCY RANGE	1 ~ 25GHz
INPUT POWER	6 Vdc	DETECTOR FUNCTION	Peak (PK) Average (AV)
ENVIRONMENTAL CONDITIONS	23deg. C, 70%RH 980 hPa	TESTED BY	Lori Chiu
TEST MODE	A		

ANTENNA POLARITY & TEST DISTANCE: HORIZONTAL AT 3 M								
NO.	FREQ. (MHz)	EMISSION LEVEL (dBuV/m)	LIMIT (dBuV/m)	MARGIN (dB)	ANTENNA HEIGHT (m)	TABLE ANGLE (Degree)	RAW VALUE (dBuV)	CORRECTION FACTOR (dB/m)
1	*2462.00	107.70 PK			1.05 H	14	75.22	32.48
2	*2462.00	103.38 AV			1.05 H	14	70.90	32.48
3	2483.50	59.67 PK	74.00	-14.33	1.25 H	287	27.11	32.56
4	2483.50	49.20 AV	54.00	-4.80	1.25 H	287	16.64	32.56
5	4924.00	52.59 PK	74.00	-21.41	1.02 H	336	14.07	38.51
6	4924.00	46.61 AV	54.00	-7.39	1.02 H	336	8.09	38.51
7	7386.00	51.17 PK	74.00	-22.83	1.00 H	22	6.34	44.83
8	7386.00	39.60 AV	54.00	-14.40	1.00 H	22	-5.23	44.83
ANTENNA POLARITY & TEST DISTANCE: VERTICAL AT 3 M								
NO.	FREQ. (MHz)	EMISSION LEVEL (dBuV/m)	LIMIT (dBuV/m)	MARGIN (dB)	ANTENNA HEIGHT (m)	TABLE ANGLE (Degree)	RAW VALUE (dBuV)	CORRECTION FACTOR (dB/m)
1	*2462.00	99.02 PK			1.14 V	171	66.54	32.48
2	*2462.00	95.08 AV			1.14 V	171	62.60	32.48
3	2483.50	57.30 PK	74.00	-16.70	1.14 V	171	24.74	32.56
4	2483.50	46.34 AV	54.00	-7.66	1.14 V	171	13.78	32.56
5	4924.00	55.87 PK	74.00	-18.13	1.00 V	187	17.35	38.51
6	4924.00	51.22 AV	54.00	-2.78	1.00 V	187	12.70	38.51
7	7386.00	53.12 PK	74.00	-20.88	1.31 V	13	8.29	44.83
8	7386.00	42.72 AV	54.00	-11.28	1.31 V	13	-2.11	44.83

- REMARKS:**
1. Emission level (dBuV/m) = Raw Value (dBuV) + Correction Factor (dB/m).
 2. Correction Factor (dB/m) = Antenna Factor (dB/m) + Cable Factor (dB).
 3. The other emission levels were very low against the limit.
 4. Margin value = Emission level – Limit value.
 5. “ * “: Fundamental frequency.

EUT TEST CONDITION		MEASUREMENT DETAIL	
CHANNEL	Channel 1	FREQUENCY RANGE	1 ~ 25GHz
INPUT POWER	6 Vdc	DETECTOR FUNCTION	Peak (PK) Average (AV)
ENVIRONMENTAL CONDITIONS	23deg. C, 70%RH 980 hPa	TESTED BY	Lori Chiu
TEST MODE	B		

ANTENNA POLARITY & TEST DISTANCE: HORIZONTAL AT 3 M								
NO.	FREQ. (MHz)	EMISSION LEVEL (dBuV/m)	LIMIT (dBuV/m)	MARGIN (dB)	ANTENNA HEIGHT (m)	TABLE ANGLE (Degree)	RAW VALUE (dBuV)	CORRECTION FACTOR (dB/m)
1	2390.00	61.11 PK	74.00	-12.89	1.08 H	27	28.89	32.22
2	2390.00	49.75 AV	54.00	-4.25	1.08 H	27	17.53	32.22
3	*2412.00	108.50 PK			1.08 H	27	76.20	32.30
4	*2412.00	104.36 AV			1.08 H	27	72.06	32.30
5	4824.00	48.40 PK	74.00	-25.60	1.18 H	45	10.07	38.33
6	4824.00	39.49 AV	54.00	-14.51	1.18 H	45	1.16	38.33
7	#7236.00	55.86 PK	88.50	-32.64	1.04 H	39	11.41	44.45
8	#7236.00	47.46 AV	84.36	-36.90	1.04 H	39	3.01	44.45
ANTENNA POLARITY & TEST DISTANCE: VERTICAL AT 3 M								
NO.	FREQ. (MHz)	EMISSION LEVEL (dBuV/m)	LIMIT (dBuV/m)	MARGIN (dB)	ANTENNA HEIGHT (m)	TABLE ANGLE (Degree)	RAW VALUE (dBuV)	CORRECTION FACTOR (dB/m)
1	2390.00	63.16 PK	74.00	-10.84	1.19 V	4	30.94	32.22
2	2390.00	47.20 AV	54.00	-6.80	1.19 V	4	14.98	32.22
3	*2412.00	103.02 PK			1.19 V	4	70.72	32.30
4	*2412.00	98.76 AV			1.19 V	4	66.46	32.30
5	4824.00	47.60 PK	74.00	-26.40	1.06 V	49	9.27	38.33
6	4824.00	38.17 AV	54.00	-15.83	1.06 V	49	-0.16	38.33
7	#7236.00	56.23 PK	83.02	-26.79	1.07 V	139	11.78	44.45
8	#7236.00	46.91 AV	78.76	-31.85	1.07 V	139	2.46	44.45

- REMARKS:**
1. Emission level (dBuV/m) = Raw Value (dBuV) + Correction Factor (dB/m).
 2. Correction Factor (dB/m) = Antenna Factor (dB/m) + Cable Factor (dB).
 3. The other emission levels were very low against the limit.
 4. Margin value = Emission level – Limit value.
 5. “ * “: Fundamental frequency.
 6. “#”:The radiated frequency is out the restricted band.



EUT TEST CONDITION		MEASUREMENT DETAIL	
CHANNEL	Channel 6	FREQUENCY RANGE	1 ~ 25GHz
INPUT POWER	6 Vdc	DETECTOR FUNCTION	Peak (PK) Average (AV)
ENVIRONMENTAL CONDITIONS	23deg. C, 70%RH 980 hPa	TESTED BY	Lori Chiu
TEST MODE	B		

ANTENNA POLARITY & TEST DISTANCE: HORIZONTAL AT 3 M								
NO.	FREQ. (MHz)	EMISSION LEVEL (dBuV/m)	LIMIT (dBuV/m)	MARGIN (dB)	ANTENNA HEIGHT (m)	TABLE ANGLE (Degree)	RAW VALUE (dBuV)	CORRECTION FACTOR (dB/m)
1	*2437.00	108.21 PK			1.06 H	200	75.82	32.39
2	*2437.00	104.19 AV			1.06 H	200	71.80	32.39
3	4874.00	49.09 PK	74.00	-24.91	1.09 H	26	10.68	38.41
4	4874.00	38.15 AV	54.00	-15.85	1.09 H	26	-0.26	38.41
5	7311.00	56.44 PK	74.00	-17.56	1.08 H	155	11.81	44.64
6	7311.00	48.34 AV	54.00	-5.66	1.08 H	155	3.71	44.64
ANTENNA POLARITY & TEST DISTANCE: VERTICAL AT 3 M								
NO.	FREQ. (MHz)	EMISSION LEVEL (dBuV/m)	LIMIT (dBuV/m)	MARGIN (dB)	ANTENNA HEIGHT (m)	TABLE ANGLE (Degree)	RAW VALUE (dBuV)	CORRECTION FACTOR (dB/m)
1	*2437.00	103.00 PK			1.11 V	359	70.61	32.39
2	*2437.00	98.12 AV			1.11 V	359	65.73	32.39
3	4874.00	48.23 PK	74.00	-25.77	1.08 V	149	9.82	38.41
4	4874.00	36.47 AV	54.00	-17.53	1.08 V	149	-1.94	38.41
5	7311.00	56.73 PK	74.00	-17.27	1.07 V	115	12.10	44.64
6	7311.00	48.04 AV	54.00	-5.96	1.07 V	115	3.41	44.64

- REMARKS:**
1. Emission level (dBuV/m) = Raw Value (dBuV) + Correction Factor (dB/m).
 2. Correction Factor (dB/m) = Antenna Factor (dB/m) + Cable Factor (dB).
 3. The other emission levels were very low against the limit.
 4. Margin value = Emission level – Limit value.
 5. “ * “: Fundamental frequency.

EUT TEST CONDITION		MEASUREMENT DETAIL	
CHANNEL	Channel 11	FREQUENCY RANGE	1 ~ 25GHz
INPUT POWER	6 Vdc	DETECTOR FUNCTION	Peak (PK) Average (AV)
ENVIRONMENTAL CONDITIONS	23deg. C, 70%RH 980 hPa	TESTED BY	Lori Chiu
TEST MODE	B		

ANTENNA POLARITY & TEST DISTANCE: HORIZONTAL AT 3 M								
NO.	FREQ. (MHz)	EMISSION LEVEL (dBuV/m)	LIMIT (dBuV/m)	MARGIN (dB)	ANTENNA HEIGHT (m)	TABLE ANGLE (Degree)	RAW VALUE (dBuV)	CORRECTION FACTOR (dB/m)
1	*2462.00	107.61 PK			1.04 H	32	75.13	32.48
2	*2462.00	103.52 AV			1.04 H	32	71.04	32.48
3	2483.50	59.17 PK	74.00	-14.83	1.04 H	32	26.61	32.56
4	2483.50	48.56 AV	54.00	-5.44	1.04 H	32	16.00	32.56
5	4924.00	49.03 PK	74.00	-24.97	1.03 H	28	10.51	38.51
6	4924.00	39.13 AV	54.00	-14.87	1.03 H	28	0.61	38.51
7	7386.00	54.74 PK	74.00	-19.26	1.03 H	173	9.91	44.83
8	7386.00	44.59 AV	54.00	-9.41	1.03 H	173	-0.24	44.83
ANTENNA POLARITY & TEST DISTANCE: VERTICAL AT 3 M								
NO.	FREQ. (MHz)	EMISSION LEVEL (dBuV/m)	LIMIT (dBuV/m)	MARGIN (dB)	ANTENNA HEIGHT (m)	TABLE ANGLE (Degree)	RAW VALUE (dBuV)	CORRECTION FACTOR (dB/m)
1	*2462.00	102.87 PK			1.20 V	20	70.39	32.48
2	*2462.00	97.66 AV			1.20 V	20	65.18	32.48
3	2483.50	63.24 PK	74.00	-10.76	1.20 V	20	30.68	32.56
4	2483.50	47.33 AV	54.00	-6.67	1.20 V	20	14.77	32.56
5	4924.00	48.58 PK	74.00	-25.42	1.04 V	114	10.06	38.51
6	4924.00	39.20 AV	54.00	-14.80	1.04 V	114	0.68	38.51
7	7386.00	55.18 PK	74.00	-18.82	1.05 V	135	10.35	44.83
8	7386.00	45.91 AV	54.00	-8.09	1.05 V	135	1.08	44.83

- REMARKS:**
1. Emission level (dBuV/m) = Raw Value (dBuV) + Correction Factor (dB/m).
 2. Correction Factor (dB/m) = Antenna Factor (dB/m) + Cable Factor (dB).
 3. The other emission levels were very low against the limit.
 4. Margin value = Emission level – Limit value.
 5. “ * “: Fundamental frequency.

802.11g OFDM MODULATION

EUT TEST CONDITION		MEASUREMENT DETAIL	
CHANNEL	Channel 1	FREQUENCY RANGE	1 ~ 25GHz
INPUT POWER	6 Vdc	DETECTOR FUNCTION	Peak (PK) Average (AV)
ENVIRONMENTAL CONDITIONS	23deg. C, 70%RH 980 hPa	TESTED BY	Lori Chiu
TEST MODE	A		

ANTENNA POLARITY & TEST DISTANCE: HORIZONTAL AT 3 M								
NO.	FREQ. (MHz)	EMISSION LEVEL (dBuV/m)	LIMIT (dBuV/m)	MARGIN (dB)	ANTENNA HEIGHT (m)	TABLE ANGLE (Degree)	RAW VALUE (dBuV)	CORRECTION FACTOR (dB/m)
1	2390.00	68.38 PK	74.00	-5.62	1.31 H	285	36.16	32.22
2	2390.00	52.05 AV	54.00	-1.95	1.31 H	285	19.83	32.22
3	*2412.00	105.47 PK			1.28 H	277	73.17	32.30
4	*2412.00	95.91 AV			1.28 H	277	63.61	32.30
5	4824.00	46.76 PK	74.00	-27.24	1.01 H	218	8.43	38.33
6	4824.00	33.73 AV	54.00	-20.27	1.01 H	218	-4.60	38.33
ANTENNA POLARITY & TEST DISTANCE: VERTICAL AT 3 M								
NO.	FREQ. (MHz)	EMISSION LEVEL (dBuV/m)	LIMIT (dBuV/m)	MARGIN (dB)	ANTENNA HEIGHT (m)	TABLE ANGLE (Degree)	RAW VALUE (dBuV)	CORRECTION FACTOR (dB/m)
1	2390.00	59.19 PK	74.00	-14.81	1.69 V	360	26.97	32.22
2	2390.00	47.26 AV	54.00	-6.74	1.69 V	360	15.04	32.22
3	*2412.00	97.22 PK			1.69 V	360	64.92	32.30
4	*2412.00	88.26 AV			1.69 V	360	55.96	32.30
5	4824.00	46.88 PK	74.00	-27.12	1.07 V	122	8.55	38.33
6	4824.00	33.84 AV	54.00	-20.16	1.07 V	122	-4.49	38.33

- REMARKS:**
1. Emission level (dBuV/m) = Raw Value (dBuV) + Correction Factor (dB/m).
 2. Correction Factor (dB/m) = Antenna Factor (dB/m) + Cable Factor (dB).
 3. The other emission levels were very low against the limit.
 4. Margin value = Emission level – Limit value.
 5. “ * “: Fundamental frequency.

EUT TEST CONDITION		MEASUREMENT DETAIL	
CHANNEL	Channel 6	FREQUENCY RANGE	1 ~ 25GHz
INPUT POWER	6 Vdc	DETECTOR FUNCTION	Peak (PK) Average (AV)
ENVIRONMENTAL CONDITIONS	23deg. C, 70%RH 980 hPa	TESTED BY	Lori Chiu
TEST MODE	A		

ANTENNA POLARITY & TEST DISTANCE: HORIZONTAL AT 3 M								
NO.	FREQ. (MHz)	EMISSION LEVEL (dBuV/m)	LIMIT (dBuV/m)	MARGIN (dB)	ANTENNA HEIGHT (m)	TABLE ANGLE (Degree)	RAW VALUE (dBuV)	CORRECTION FACTOR (dB/m)
1	*2437.00	107.76 PK			1.27 H	271	75.37	32.39
2	*2437.00	97.93 AV			1.27 H	271	65.54	32.39
3	4874.00	47.24 PK	74.00	-26.76	1.00 H	123	8.83	38.41
4	4874.00	35.82 AV	54.00	-18.18	1.00 H	123	-2.59	38.41
ANTENNA POLARITY & TEST DISTANCE: VERTICAL AT 3 M								
NO.	FREQ. (MHz)	EMISSION LEVEL (dBuV/m)	LIMIT (dBuV/m)	MARGIN (dB)	ANTENNA HEIGHT (m)	TABLE ANGLE (Degree)	RAW VALUE (dBuV)	CORRECTION FACTOR (dB/m)
1	*2437.00	99.67 PK			1.11 V	20	67.28	32.39
2	*2437.00	90.58 AV			1.11 V	20	58.19	32.39
3	4874.00	46.57 PK	74.00	-27.43	1.01 V	114	8.16	38.41
4	4874.00	35.26 AV	54.00	-18.74	1.01 V	114	-3.15	38.41

- REMARKS:**
1. Emission level (dBuV/m) = Raw Value (dBuV) + Correction Factor (dB/m).
 2. Correction Factor (dB/m) = Antenna Factor (dB/m) + Cable Factor (dB).
 3. The other emission levels were very low against the limit.
 4. Margin value = Emission level – Limit value.
 5. “ * ”: Fundamental frequency.

EUT TEST CONDITION		MEASUREMENT DETAIL	
CHANNEL	Channel 11	FREQUENCY RANGE	1 ~ 25GHz
INPUT POWER	6 Vdc	DETECTOR FUNCTION	Peak (PK) Average (AV)
ENVIRONMENTAL CONDITIONS	23deg. C, 70%RH 980 hPa	TESTED BY	Lori Chiu
TEST MODE	A		

ANTENNA POLARITY & TEST DISTANCE: HORIZONTAL AT 3 M								
NO.	FREQ. (MHz)	EMISSION LEVEL (dBuV/m)	LIMIT (dBuV/m)	MARGIN (dB)	ANTENNA HEIGHT (m)	TABLE ANGLE (Degree)	RAW VALUE (dBuV)	CORRECTION FACTOR (dB/m)
1	*2462.00	107.34 PK			1.24 H	285	74.86	32.48
2	*2462.00	97.19 AV			1.24 H	285	64.71	32.48
3	2483.50	69.36 PK	74.00	-4.64	1.23 H	286	36.80	32.56
4	2483.50	52.75 AV	54.00	-1.25	1.23 H	286	20.19	32.56
5	4924.00	47.14 PK	74.00	-26.86	1.22 H	245	8.62	38.51
6	4924.00	35.79 AV	54.00	-18.21	1.22 H	245	-2.73	38.51
ANTENNA POLARITY & TEST DISTANCE: VERTICAL AT 3 M								
NO.	FREQ. (MHz)	EMISSION LEVEL (dBuV/m)	LIMIT (dBuV/m)	MARGIN (dB)	ANTENNA HEIGHT (m)	TABLE ANGLE (Degree)	RAW VALUE (dBuV)	CORRECTION FACTOR (dB/m)
1	*2462.00	99.34 PK			1.52 V	1	66.86	32.48
2	*2462.00	90.09 AV			1.52 V	1	57.61	32.48
3	2483.50	59.37 PK	74.00	-14.63	1.53 V	1	26.81	32.56
4	2483.50	47.54 AV	54.00	-6.46	1.53 V	1	14.98	32.56
5	4924.00	48.46 PK	74.00	-25.54	1.10 V	207	9.94	38.51
6	4924.00	36.07 AV	54.00	-17.93	1.10 V	207	-2.45	38.51

- REMARKS:**
1. Emission level (dBuV/m) = Raw Value (dBuV) + Correction Factor (dB/m).
 2. Correction Factor (dB/m) = Antenna Factor (dB/m) + Cable Factor (dB).
 3. The other emission levels were very low against the limit.
 4. Margin value = Emission level – Limit value.
 5. “ * ”: Fundamental frequency.



EUT TEST CONDITION		MEASUREMENT DETAIL	
CHANNEL	Channel 1	FREQUENCY RANGE	1 ~ 25GHz
INPUT POWER	6 Vdc	DETECTOR FUNCTION	Peak (PK) Average (AV)
ENVIRONMENTAL CONDITIONS	23deg. C, 70%RH 980 hPa	TESTED BY	Lori Chiu
TEST MODE	B		

ANTENNA POLARITY & TEST DISTANCE: HORIZONTAL AT 3 M								
NO.	FREQ. (MHz)	EMISSION LEVEL (dBuV/m)	LIMIT (dBuV/m)	MARGIN (dB)	ANTENNA HEIGHT (m)	TABLE ANGLE (Degree)	RAW VALUE (dBuV)	CORRECTION FACTOR (dB/m)
1	2390.00	68.75 PK	74.00	-5.25	1.09 H	28	36.53	32.22
2	2390.00	52.72 AV	54.00	-1.28	1.09 H	28	20.50	32.22
3	*2412.00	105.58 PK			1.06 H	25	73.28	32.30
4	*2412.00	96.58 AV			1.06 H	25	64.28	32.30
5	4824.00	46.24 PK	74.00	-27.76	1.06 H	246	7.91	38.33
6	4824.00	34.13 AV	54.00	-19.87	1.06 H	246	-4.20	38.33
ANTENNA POLARITY & TEST DISTANCE: VERTICAL AT 3 M								
NO.	FREQ. (MHz)	EMISSION LEVEL (dBuV/m)	LIMIT (dBuV/m)	MARGIN (dB)	ANTENNA HEIGHT (m)	TABLE ANGLE (Degree)	RAW VALUE (dBuV)	CORRECTION FACTOR (dB/m)
1	2390.00	60.04 PK	74.00	-13.96	1.14 V	47	27.82	32.22
2	2390.00	47.13 AV	54.00	-6.87	1.14 V	47	14.91	32.22
3	*2412.00	97.74 PK			1.14 V	47	65.44	32.30
4	*2412.00	88.64 AV			1.14 V	47	56.34	32.30
5	4824.00	46.37 PK	74.00	-27.63	1.11 V	241	8.04	38.33
6	4824.00	34.25 AV	54.00	-19.75	1.11 V	241	-4.08	38.33

- REMARKS:**
1. Emission level (dBuV/m) = Raw Value (dBuV) + Correction Factor (dB/m).
 2. Correction Factor (dB/m) = Antenna Factor (dB/m) + Cable Factor (dB).
 3. The other emission levels were very low against the limit.
 4. Margin value = Emission level – Limit value.
 5. “ * ”: Fundamental frequency.

EUT TEST CONDITION		MEASUREMENT DETAIL	
CHANNEL	Channel 6	FREQUENCY RANGE	1 ~ 25GHz
INPUT POWER	6 Vdc	DETECTOR FUNCTION	Peak (PK) Average (AV)
ENVIRONMENTAL CONDITIONS	23deg. C, 70%RH 980 hPa	TESTED BY	Lori Chiu
TEST MODE	B		

ANTENNA POLARITY & TEST DISTANCE: HORIZONTAL AT 3 M								
NO.	FREQ. (MHz)	EMISSION LEVEL (dBuV/m)	LIMIT (dBuV/m)	MARGIN (dB)	ANTENNA HEIGHT (m)	TABLE ANGLE (Degree)	RAW VALUE (dBuV)	CORRECTION FACTOR (dB/m)
1	*2437.00	106.46 PK			1.32 H	52	74.07	32.39
2	*2437.00	97.39 AV			1.32 H	52	65.00	32.39
3	4874.00	46.74 PK	74.00	-27.26	1.10 H	209	8.33	38.41
4	4874.00	34.58 AV	54.00	-19.42	1.10 H	209	-3.83	38.41
ANTENNA POLARITY & TEST DISTANCE: VERTICAL AT 3 M								
NO.	FREQ. (MHz)	EMISSION LEVEL (dBuV/m)	LIMIT (dBuV/m)	MARGIN (dB)	ANTENNA HEIGHT (m)	TABLE ANGLE (Degree)	RAW VALUE (dBuV)	CORRECTION FACTOR (dB/m)
1	*2437.00	98.33 PK			1.20 V	51	65.94	32.39
2	*2437.00	89.56 AV			1.20 V	51	57.17	32.39
3	4874.00	47.21 PK	74.00	-26.79	1.25 V	64	8.80	38.41
4	4874.00	34.93 AV	54.00	-19.07	1.25 V	64	-3.48	38.41

- REMARKS:**
1. Emission level (dBuV/m) = Raw Value (dBuV) + Correction Factor (dB/m).
 2. Correction Factor (dB/m) = Antenna Factor (dB/m) + Cable Factor (dB).
 3. The other emission levels were very low against the limit.
 4. Margin value = Emission level – Limit value.
 5. “ * ”: Fundamental frequency.

EUT TEST CONDITION		MEASUREMENT DETAIL	
CHANNEL	Channel 11	FREQUENCY RANGE	1 ~ 25GHz
INPUT POWER	6 Vdc	DETECTOR FUNCTION	Peak (PK) Average (AV)
ENVIRONMENTAL CONDITIONS	23deg. C, 70%RH 980 hPa	TESTED BY	Lori Chiu
TEST MODE	B		

ANTENNA POLARITY & TEST DISTANCE: HORIZONTAL AT 3 M								
NO.	FREQ. (MHz)	EMISSION LEVEL (dBuV/m)	LIMIT (dBuV/m)	MARGIN (dB)	ANTENNA HEIGHT (m)	TABLE ANGLE (Degree)	RAW VALUE (dBuV)	CORRECTION FACTOR (dB/m)
1	*2462.00	105.76 PK			1.28 H	46	73.28	32.48
2	*2462.00	96.61 AV			1.28 H	46	64.13	32.48
3	2483.50	68.09 PK	74.00	-5.91	1.07 H	24	35.53	32.56
4	2483.50	52.50 AV	54.00	-1.50	1.07 H	24	19.94	32.56
5	4924.00	46.34 PK	74.00	-27.66	1.01 H	221	7.83	38.51
6	4924.00	34.28 AV	54.00	-19.72	1.01 H	221	-4.23	38.51
ANTENNA POLARITY & TEST DISTANCE: VERTICAL AT 3 M								
NO.	FREQ. (MHz)	EMISSION LEVEL (dBuV/m)	LIMIT (dBuV/m)	MARGIN (dB)	ANTENNA HEIGHT (m)	TABLE ANGLE (Degree)	RAW VALUE (dBuV)	CORRECTION FACTOR (dB/m)
1	*2462.00	97.83 PK			1.16 V	50	65.35	32.48
2	*2462.00	88.72 AV			1.16 V	50	56.24	32.48
3	2483.50	60.15 PK	74.00	-13.85	1.16 V	50	27.59	32.56
4	2483.50	47.26 AV	54.00	-6.74	1.16 V	50	14.70	32.56
5	4924.00	46.57 PK	74.00	-27.43	1.11 V	158	8.06	38.51
6	4924.00	34.60 AV	54.00	-19.40	1.11 V	158	-3.91	38.51

- REMARKS:**
1. Emission level (dBuV/m) = Raw Value (dBuV) + Correction Factor (dB/m).
 2. Correction Factor (dB/m) = Antenna Factor (dB/m) + Cable Factor (dB).
 3. The other emission levels were very low against the limit.
 4. Margin value = Emission level – Limit value.
 5. “ * ”: Fundamental frequency.

BELOW 1GHz WORST-CASE DATA : 802.11g OFDM MODULATION

EUT TEST CONDITION		MEASUREMENT DETAIL	
CHANNEL	Channel 6	FREQUENCY RANGE	Below 1000MHz
INPUT POWER (SYSTEM)	6 Vdc	DETECTOR FUNCTION	Quasi-Peak
ENVIRONMENTAL CONDITIONS	25deg. C, 65%RH 980 hPa	TESTED BY	Dean Wang
TEST MODE	A		

ANTENNA POLARITY & TEST DISTANCE: HORIZONTAL AT 3 M								
NO.	FREQ. (MHz)	EMISSION LEVEL (dBuV/m)	LIMIT (dBuV/m)	MARGIN (dB)	ANTENNA HEIGHT (m)	TABLE ANGLE (Degree)	RAW VALUE (dBuV)	CORRECTION FACTOR (dB/m)
1	107.54	39.44 QP	43.50	-4.06	1.50 H	88	29.20	10.24
2	191.25	36.31 QP	43.50	-7.19	1.45 H	214	25.02	11.29
3	311.88	37.45 QP	46.00	-8.55	1.25 H	211	23.50	13.95
4	543.10	38.45 QP	46.00	-7.55	1.20 H	114	17.90	20.55
5	663.64	34.74 QP	46.00	-11.26	1.50 H	144	12.31	22.43
6	949.48	35.25 QP	46.00	-10.75	1.75 H	25	8.76	26.49
ANTENNA POLARITY & TEST DISTANCE: VERTICAL AT 3 M								
NO.	FREQ. (MHz)	EMISSION LEVEL (dBuV/m)	LIMIT (dBuV/m)	MARGIN (dB)	ANTENNA HEIGHT (m)	TABLE ANGLE (Degree)	RAW VALUE (dBuV)	CORRECTION FACTOR (dB/m)
1	55.15	35.62 QP	40.00	-4.38	1.25 V	288	22.08	13.54
2	74.57	30.45 QP	40.00	-9.55	1.25 V	35	20.49	9.96
3	111.64	37.54 QP	43.50	-5.96	1.50 V	251	26.80	10.74
4	665.61	37.61 QP	46.00	-8.39	1.15 V	135	15.17	22.44
5	702.55	34.75 QP	46.00	-11.25	1.25 V	128	11.96	22.79
6	949.51	36.01 QP	46.00	-9.99	1.00 V	211	9.52	26.49

- REMARKS:**
1. Emission level (dBuV/m) = Raw Value (dBuV) + Correction Factor (dB/m).
 2. Correction Factor (dB/m) = Antenna Factor (dB/m) + Cable Factor (dB).
 3. The other emission levels were very low against the limit.
 4. Margin value = Emission level – Limit value.

EUT TEST CONDITION		MEASUREMENT DETAIL	
CHANNEL	Channel 6	FREQUENCY RANGE	Below 1000MHz
INPUT POWER (SYSTEM)	6 Vdc	DETECTOR FUNCTION	Quasi-Peak
ENVIRONMENTAL CONDITIONS	25deg. C, 65%RH 980 hPa	TESTED BY	Dean Wang
TEST MODE	B		

ANTENNA POLARITY & TEST DISTANCE: HORIZONTAL AT 3 M								
NO.	FREQ. (MHz)	EMISSION LEVEL (dBuV/m)	LIMIT (dBuV/m)	MARGIN (dB)	ANTENNA HEIGHT (m)	TABLE ANGLE (Degree)	RAW VALUE (dBuV)	CORRECTION FACTOR (dB/m)
1	107.67	39.48 QP	43.50	-4.02	1.25 H	130	29.23	10.26
2	191.28	36.40 QP	43.50	-7.10	1.50 H	214	25.11	11.29
3	311.82	37.37 QP	46.00	-8.63	1.00 H	298	23.43	13.95
4	543.19	38.67 QP	46.00	-7.33	1.25 H	118	18.11	20.56
5	663.74	34.85 QP	46.00	-11.15	1.25 H	157	12.42	22.43
6	949.55	35.12 QP	46.00	-10.88	2.00 H	13	8.64	26.49
ANTENNA POLARITY & TEST DISTANCE: VERTICAL AT 3 M								
NO.	FREQ. (MHz)	EMISSION LEVEL (dBuV/m)	LIMIT (dBuV/m)	MARGIN (dB)	ANTENNA HEIGHT (m)	TABLE ANGLE (Degree)	RAW VALUE (dBuV)	CORRECTION FACTOR (dB/m)
1	55.18	35.72 QP	40.00	-4.28	1.25 V	292	22.19	13.53
2	74.62	30.49 QP	40.00	-9.51	1.25 V	1	20.54	9.94
3	111.56	37.60 QP	43.50	-5.90	1.50 V	247	26.87	10.73
4	665.68	37.67 QP	46.00	-8.33	1.25 V	142	15.22	22.45
5	702.62	34.81 QP	46.00	-11.19	1.25 V	118	12.01	22.79
6	949.55	36.04 QP	46.00	-9.96	1.00 V	4	9.56	26.49

- REMARKS:**
1. Emission level (dBuV/m) = Raw Value (dBuV) + Correction Factor (dB/m).
 2. Correction Factor (dB/m) = Antenna Factor (dB/m) + Cable Factor (dB).
 3. The other emission levels were very low against the limit.
 4. Margin value = Emission level – Limit value.

4.2 6dB BANDWIDTH MEASUREMENT

4.2.1 LIMITS OF 6dB BANDWIDTH MEASUREMENT

The minimum of 6dB Bandwidth Measurement is 0.5 MHz.

4.2.2 TEST INSTRUMENTS

DESCRIPTION & MANUFACTURER	MODEL NO.	SERIAL NO.	DATE OF CALIBRATION	DUE DATE OF CALIBRATION
R&S SPECTRUM ANALYZER	FSP40	100041	May 13, 2009	May 12, 2010

NOTE: The calibration interval of the above test instruments is 12 months and the calibrations are traceable to NML/ROC and NIST/USA.

4.2.3 TEST PROCEDURE

The transmitter output was connected to the spectrum analyzer through an attenuator. The bandwidth of the fundamental frequency was measured by spectrum analyzer with 100kHz RBW and 300kHz VBW. The 6dB bandwidth is defined as the total spectrum the power of which is higher than peak power minus 6dB.

4.2.4 DEVIATION FROM TEST STANDARD

No deviation.

4.2.5 TEST SETUP



4.2.6 EUT OPERATING CONDITIONS

The software provided by client to enable the EUT under transmission condition continuously at lowest, middle and highest channel frequencies individually.

4.2.7 TEST RESULTS

802.11b DSSS MODULATION

MODULATION TYPE	DBPSK	TRANSFER RATE	1.0Mbps
INPUT POWER	120 Vac, 60 Hz	ENVIRONMENTAL CONDITIONS	23 deg. C, 70% RH, 980 hPa
TESTED BY	Lori Chiu		

CHANNEL	CHANNEL FREQUENCY (MHz)	6dB BANDWIDTH (MHz)	MINIMUM LIMIT (MHz)	PASS / FAIL
1	2412	7.61	0.5	PASS
6	2437	7.61	0.5	PASS
11	2462	7.59	0.5	PASS

CH 1

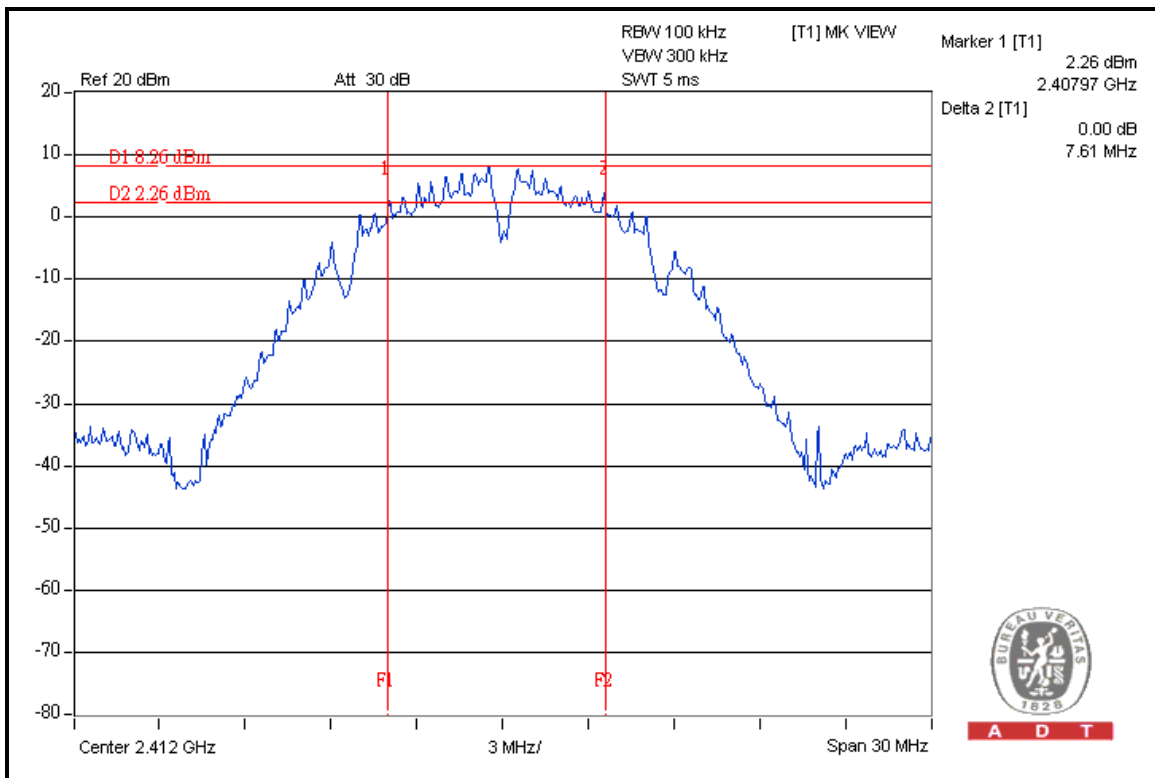



A D T

CH 6

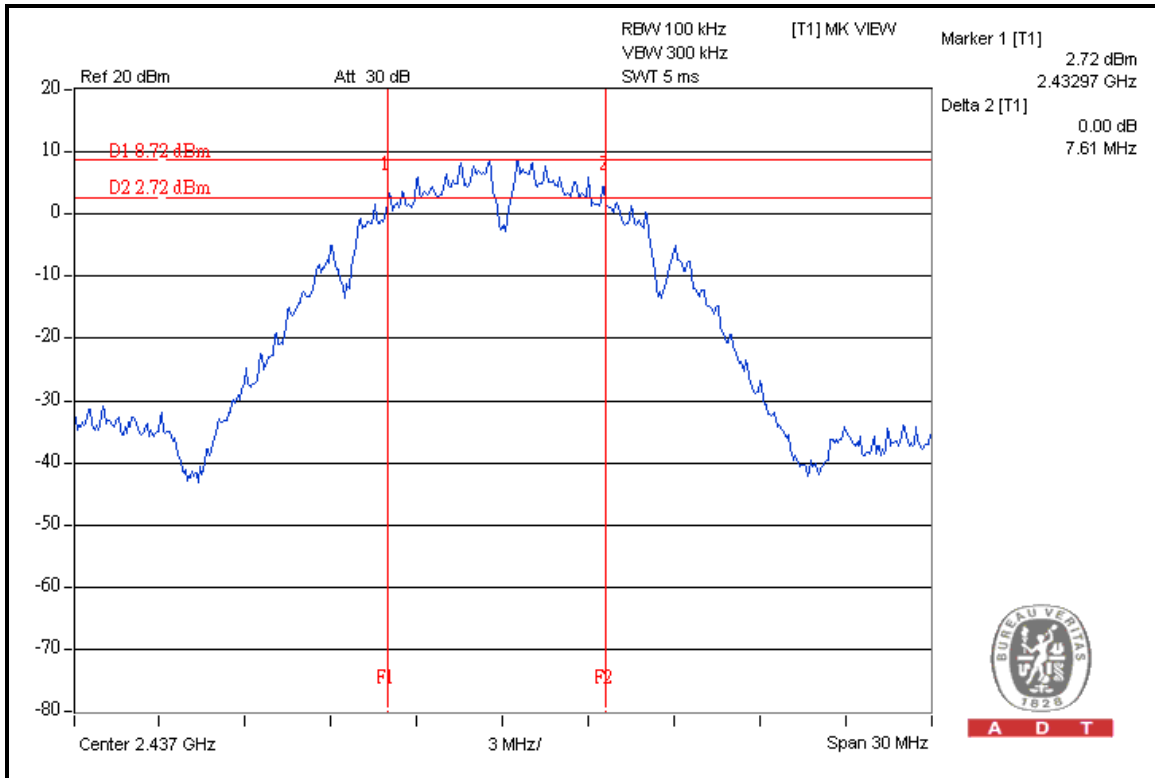

CH 11

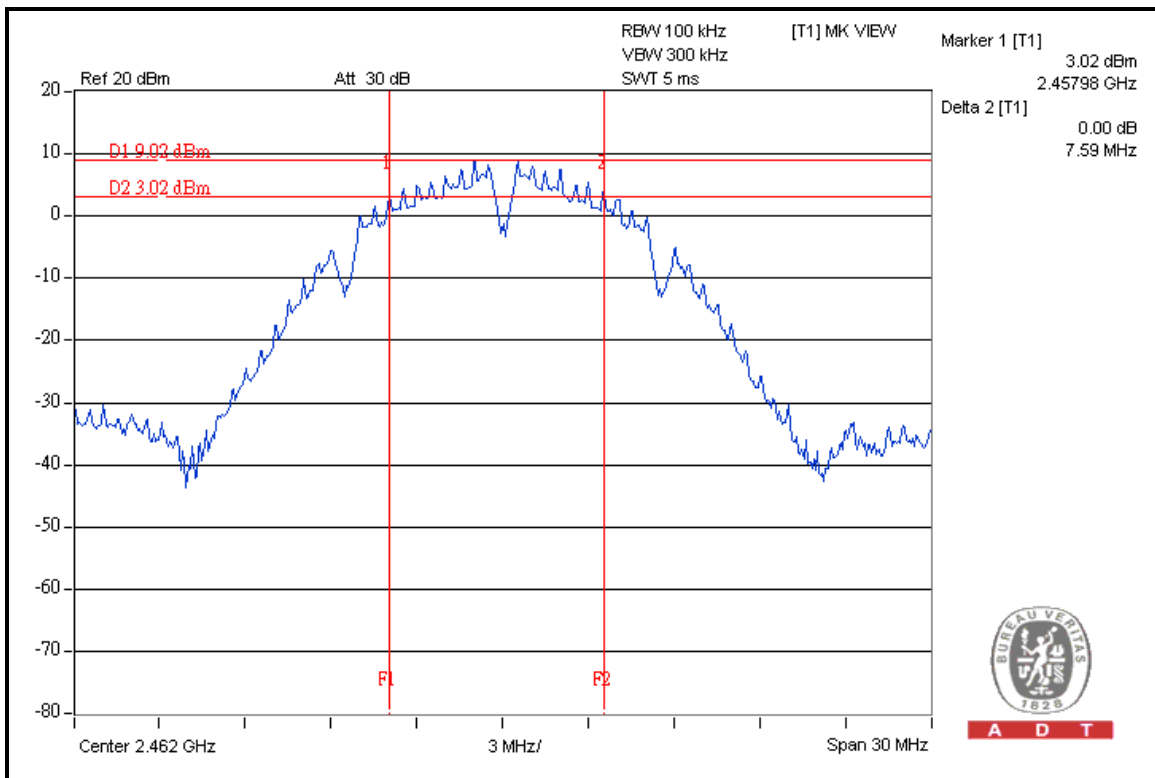



A D T

802.11g OFDM MODULATION

MODULATION TYPE	BPSK	TRANSFER RATE	6.0Mbps
INPUT POWER	120 Vac, 60 Hz	ENVIRONMENTAL CONDITIONS	23 deg. C, 70% RH, 980 hPa
TESTED BY	Lori Chiu		

CHANNEL	CHANNEL FREQUENCY (MHz)	6dB BANDWIDTH (MHz)	MINIMUM LIMIT (MHz)	PASS / FAIL
1	2412	14.16	0.5	PASS
6	2437	15.34	0.5	PASS
11	2462	15.32	0.5	PASS

CH 1

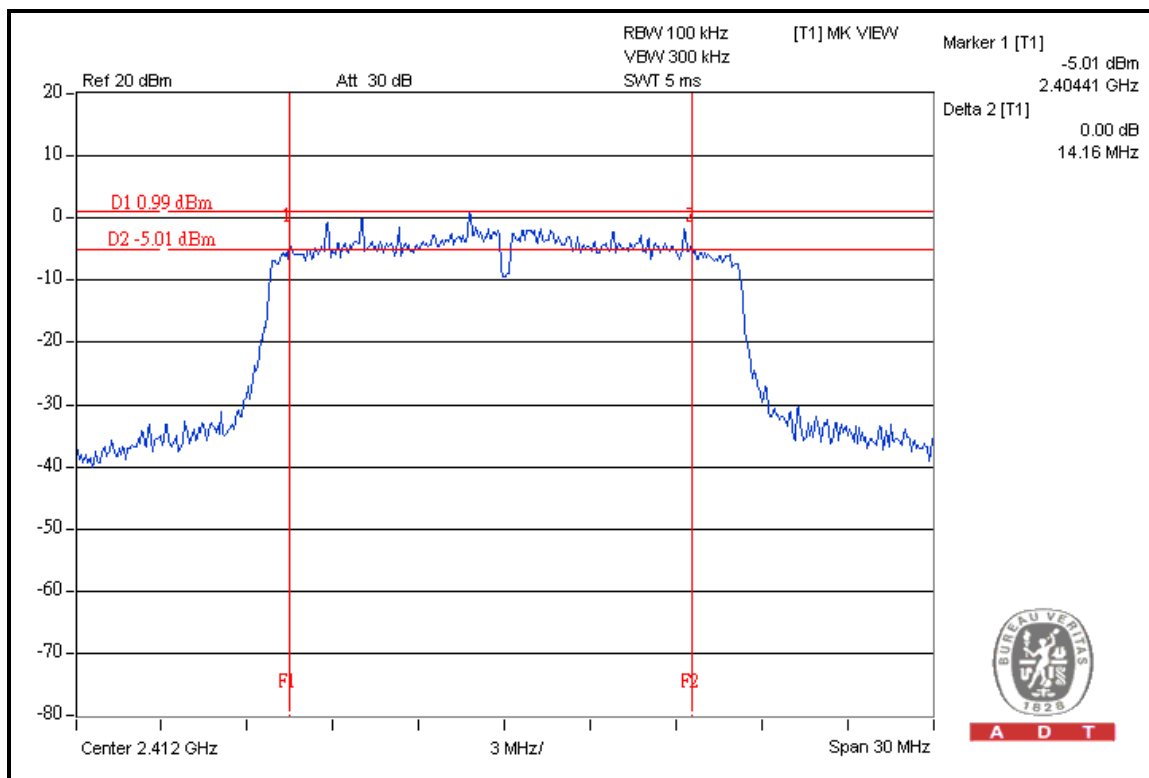

A D T



A D T

CH 6

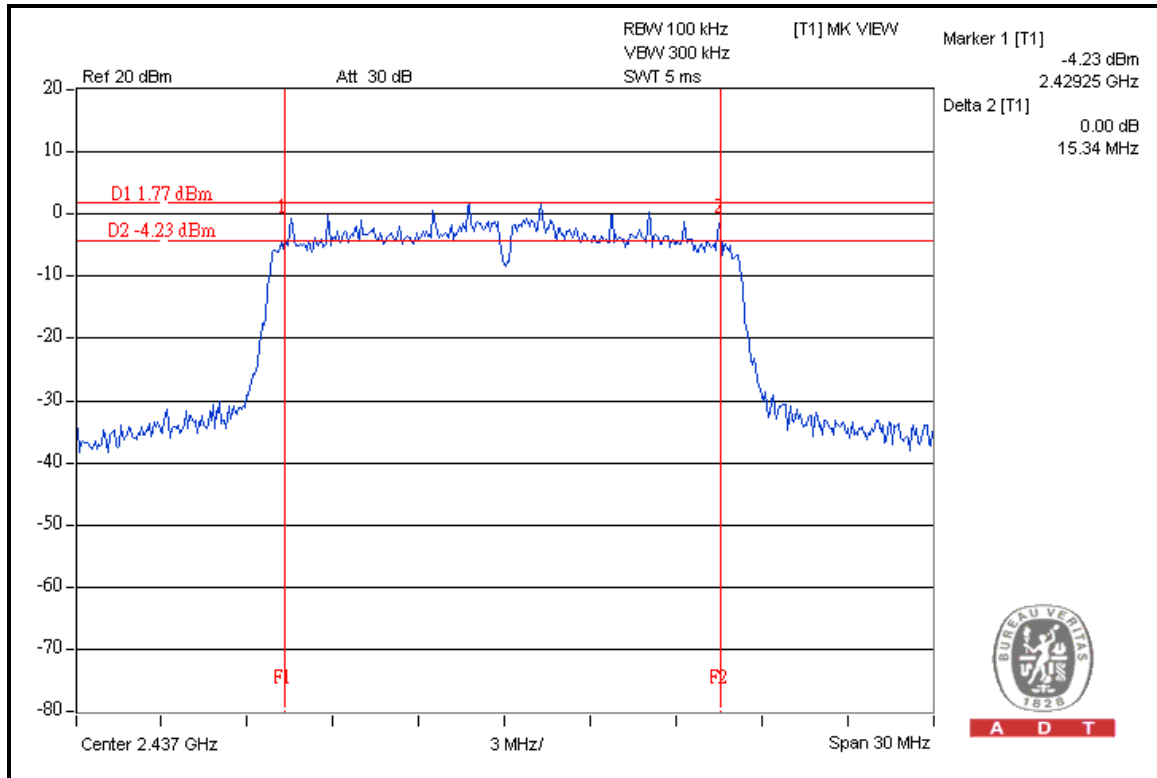

CH 11

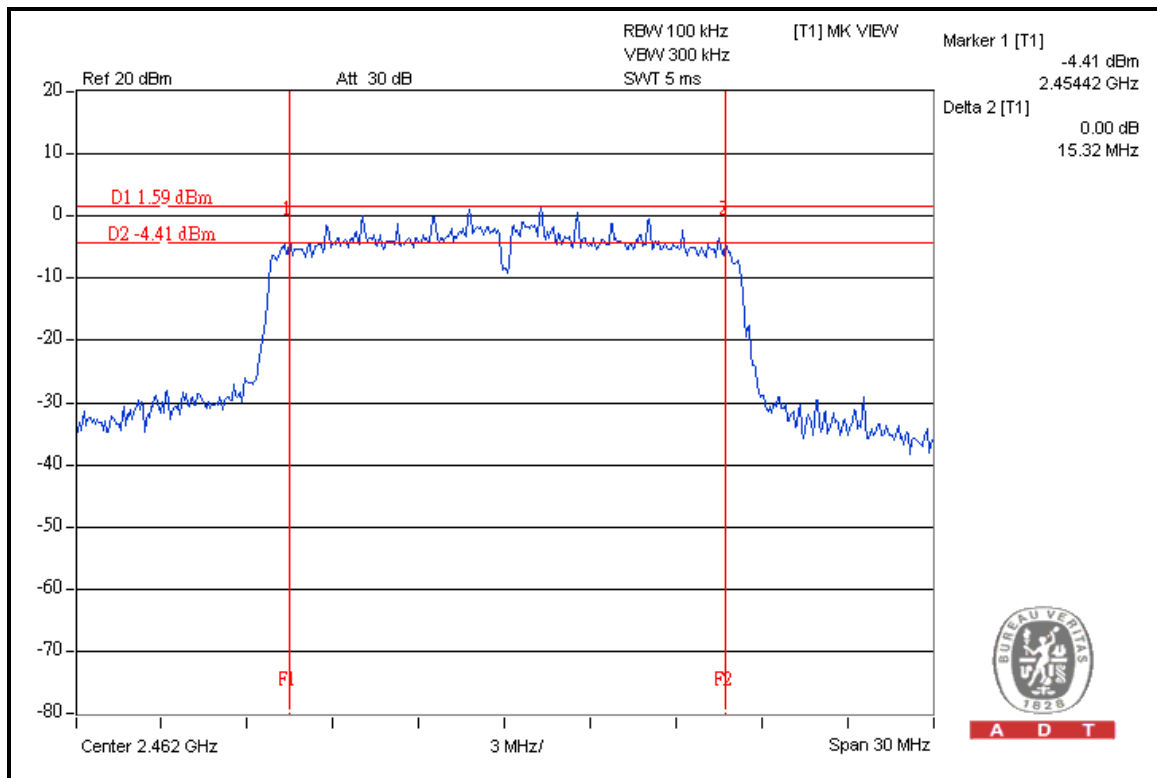

4.3 MAXIMUM PEAK OUTPUT POWER

4.3.1 LIMITS OF MAXIMUM PEAK OUTPUT POWER MEASUREMENT

The Maximum Peak Output Power Measurement is 30dBm.

4.3.2 INSTRUMENTS

DESCRIPTION & MANUFACTURER	MODEL NO.	SERIAL NO.	DATE OF CALIBRATION	DUE DATE OF CALIBRATION
High Speed Peak Power Meter	ML2495A	0824011	Jul. 30, 2009	Jul. 29, 2010
Power Sensor	MA2411B	0738171	Jul. 30, 2009	Jul. 29, 2010

NOTE:

1. The calibration interval of the above test instruments is 12 months and the calibrations are traceable to NML/ROC and NIST/USA.
2. Measurement Bandwidth of ML2495A is 65MHz greater than 6dB bandwidth of emission.

4.4.3 TEST PROCEDURES

A power sensor was used on the output port of the EUT. A power meter was used to read the response of the power sensor. Record the power level.

4.4.4 DEVIATION FROM TEST STANDARD

No deviation.

4.4.5 TEST SETUP

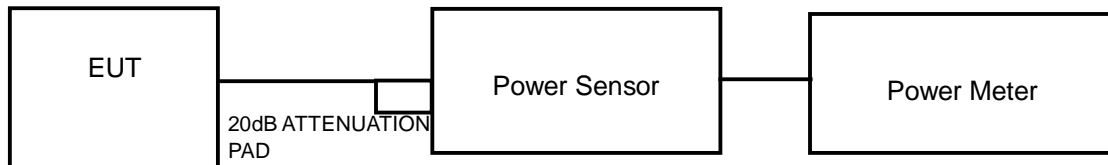

4.4.6 EUT OPERATING CONDITIONS

Same as item 4.3.6.

4.4.7 TEST RESULTS

802.11b DSSS MODULATION

MODULATION TYPE	DBPSK	TRANSFER RATE	1.0Mbps
INPUT POWER	120 Vac, 60 Hz	ENVIRONMENTAL CONDITIONS	23 deg. C, 70% RH, 980 hPa
TESTED BY	Lori Chiu		

CHAN	CHANNEL FREQUENCY (MHz)	PEAK POWER OUTPUT (mW)	PEAK POWER OUTPUT (dBm)	PEAK POWER LIMIT (dBm)	PASS/FAIL
1	2412	100.23	20.01	30	PASS
6	2437	109.40	20.39	30	PASS
11	2462	115.08	20.61	30	PASS

802.11g OFDM MODULATION

MODULATION TYPE	BPSK	TRANSFER RATE	6.0Mbps
INPUT POWER	120 Vac, 60 Hz	ENVIRONMENTAL CONDITIONS	23 deg. C, 70% RH, 980 hPa
TESTED BY	Lori Chiu		

CHAN	CHANNEL FREQUENCY (MHz)	PEAK POWER OUTPUT (mW)	PEAK POWER OUTPUT (dBm)	PEAK POWER LIMIT (dBm)	PASS/FAIL
1	2412	154.53	21.89	30	PASS
6	2437	193.64	22.87	30	PASS
11	2462	185.35	22.68	30	PASS

4.4 POWER SPECTRAL DENSITY MEASUREMENT

4.4.1 LIMITS OF POWER SPECTRAL DENSITY MEASUREMENT

The Maximum of Power Spectral Density Measurement is 8dBm.

4.4.2 TEST INSTRUMENTS

DESCRIPTION & MANUFACTURER	MODEL NO.	SERIAL NO.	DATE OF CALIBRATION	DUE DATE OF CALIBRATION
R&S SPECTRUM ANALYZER	FSP40	100041	May 13, 2009	May 12, 2010

NOTE: The calibration interval of the above test instruments is 12 months and the calibrations are traceable to NML/ROC and NIST/USA.

4.4.3 TEST PROCEDURE

The transmitter output was connected to the spectrum analyzer through an attenuator, the bandwidth of the fundamental frequency was measured with the spectrum analyzer using 3kHz RBW and 30kHz VBW, set sweep time = span/3kHz. The power spectral density was measured and recorded.

The sweep time is allowed to be longer than span/3kHz for a full response of the mixer in the spectrum analyzer.

4.4.4 DEVIATION FROM TEST STANDARD

No deviation.

4.4.5 TEST SETUP

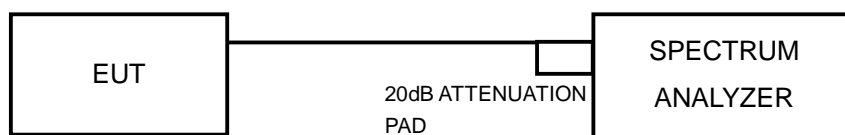

4.4.6 EUT OPERATING CONDITION

Same as item 4.3.6.



A D T

CH 6

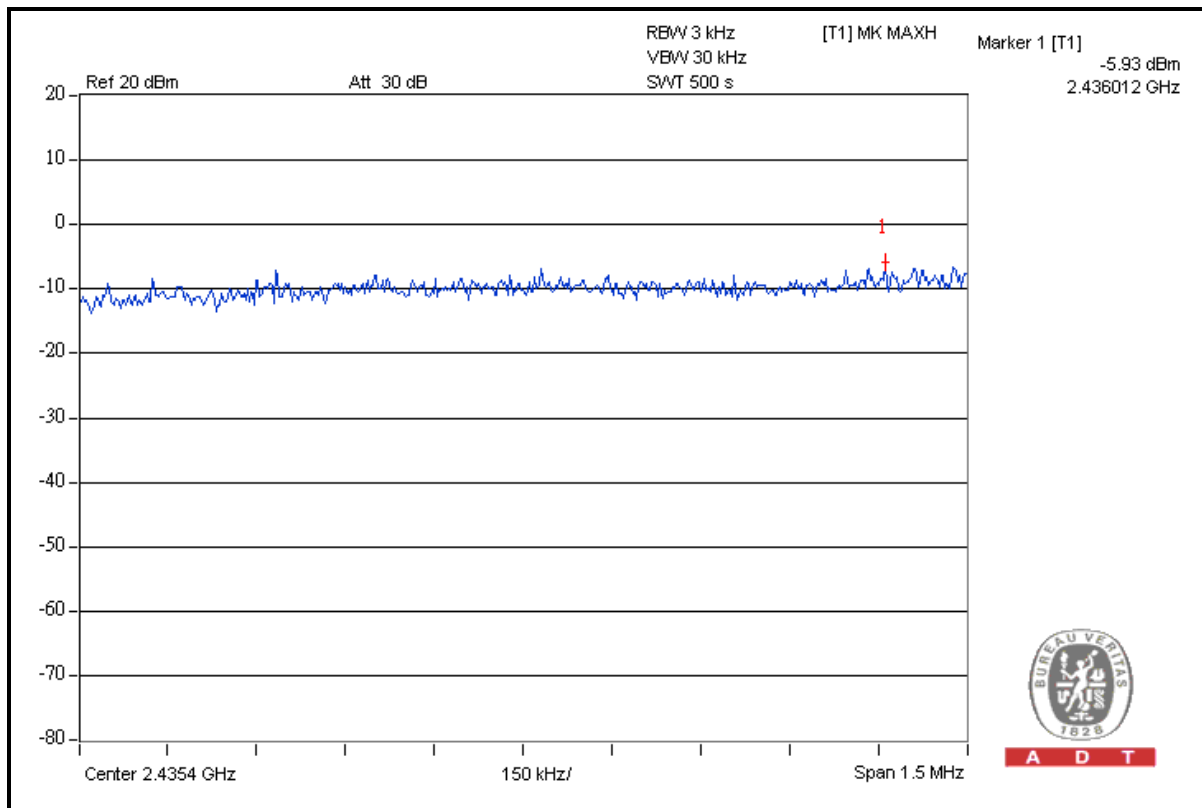

A D T

CH 11

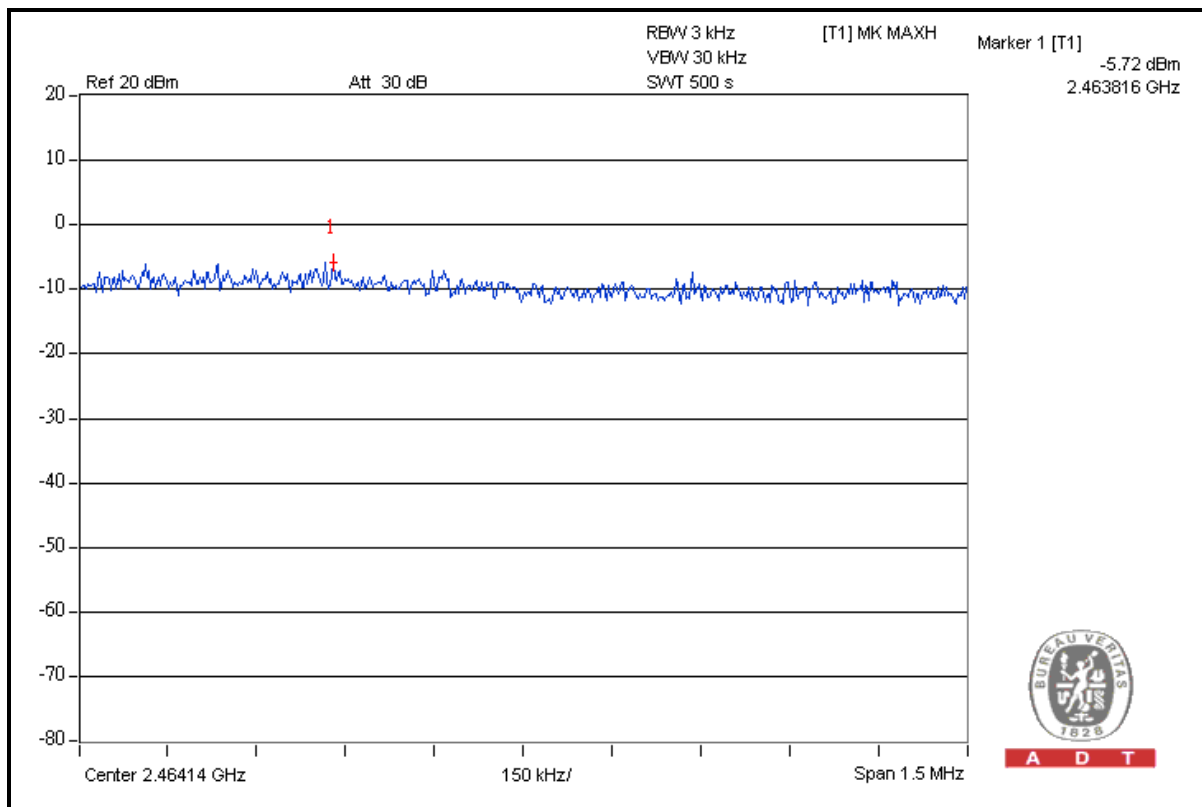

A D T



A D T

CH 6

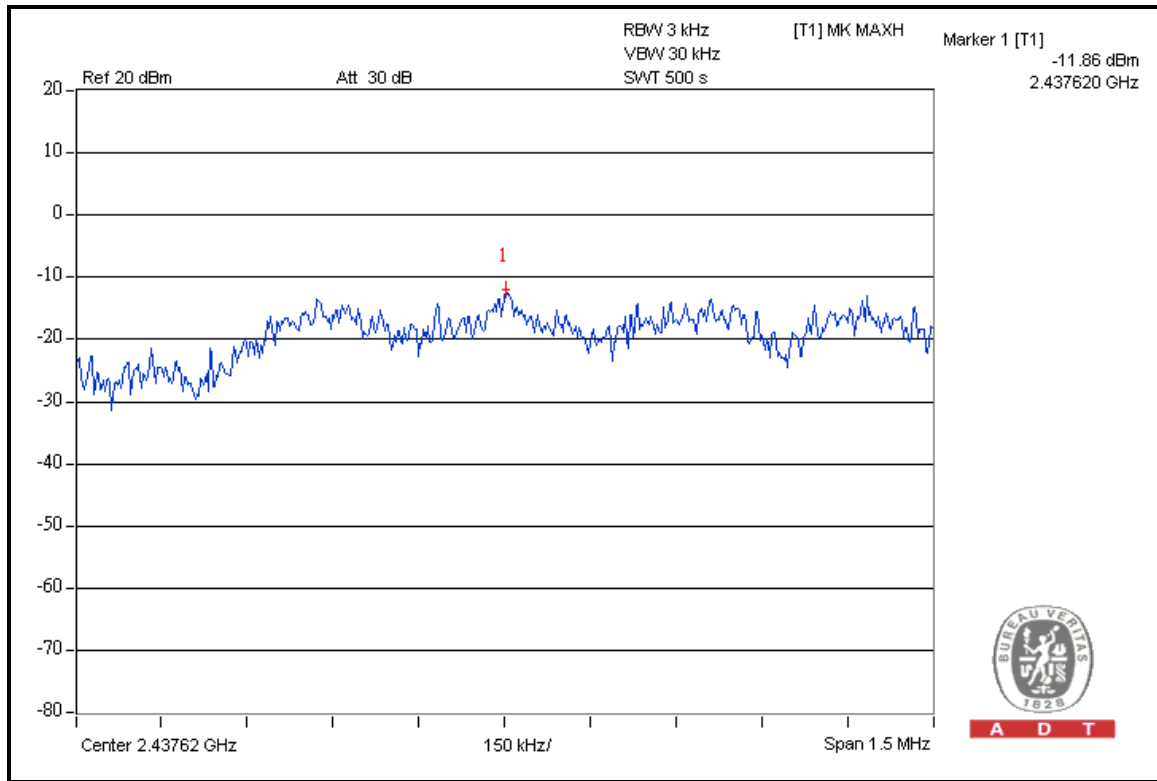

A D T

CH 11

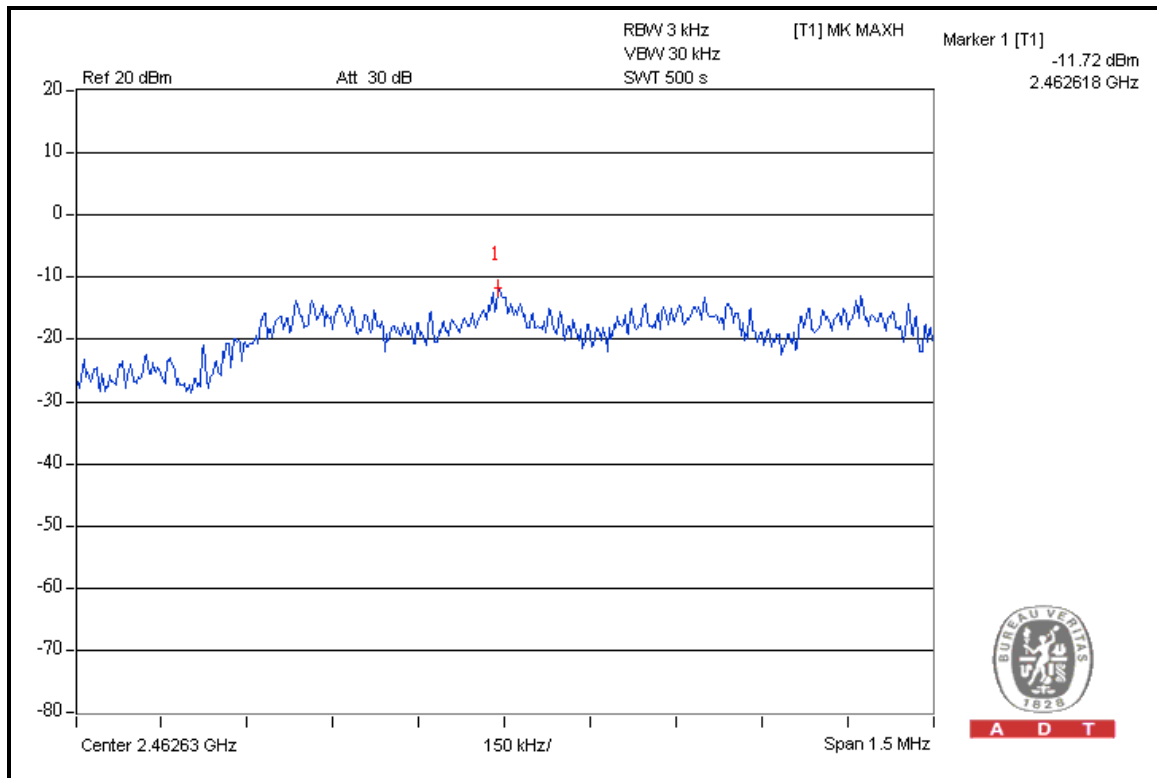

A D T

4.5 BAND EDGES MEASUREMENT

4.5.1 LIMITS OF BAND EDGES MEASUREMENT

Below -20dB of the highest emission level of operating band (in 100kHz Resolution Bandwidth).

4.5.2 TEST INSTRUMENTS

DESCRIPTION & MANUFACTURER	MODEL NO.	SERIAL NO.	DATE OF CALIBRATION	DUE DATE OF CALIBRATION
R&S SPECTRUM ANALYZER	FSP40	100041	May 13, 2009	May 12, 2010

NOTE: The calibration interval of the above test instruments is 12 months and the calibrations are traceable to NML/ROC and NIST/USA.

4.5.3 TEST PROCEDURE

The transmitter output was connected to the spectrum analyzer via a low lose cable. Set both RBW and VBW of spectrum analyzer to 100kHz and 300kHz with suitable frequency span including 100MHz bandwidth from band edge. The band edges was measured and recorded.

The spectrum plots (Peak RBW = 100kHz, VBW = 300kHz; Average RBW = 1MHz, VBW = 10Hz) are attached on the following pages.

4.5.4 DEVIATION FROM TEST STANDARD

No deviation.

4.5.5 EUT OPERATING CONDITION

Same as item 4.3.6.

4.5.6 TEST RESULTS

The spectrum plots are attached on the following 12 images. D1 line indicates the highest level, and D2 line indicates the 20dB offset below D1. It shows compliance with the requirement in part 15.247(d).

802.11b DSSS MODULATION

TEST MODE A

NOTE 1: The band edge emission plot on the next page shows 49.93dBc between carrier maximum power and local maximum emission in restrict band (2.38900GHz). The emission of carrier strength list in the test result of channel 1 at the item 4.1.7 is 108.68dBuV/m (Peak), so the maximum field strength in restrict band is $108.68 - 49.93 = 58.75$ dBuV/m which is under 74dBuV/m limit.

The band edge emission plot on the next page shows 57.40dBc between carrier maximum power and local maximum emission in restrict band (2.38900GHz). The emission of carrier strength list in the test result of channel 1 at the item 4.1.7 is 104.97BuV/m (Average), so the maximum field strength in restrict band is $104.97 - 57.40 = 47.57$ dBuV/m which is under 54dBuV/m limit.

NOTE 2: The band edge emission plot on the next second page shows 52.13dBc between carrier maximum power and local maximum emission in restrict band (2.48500GHz). The emission of carrier strength list in the test result of channel 11 at the item 4.1.7 is 107.70dBuV/m (Peak), so the maximum field strength in restrict band is $107.70 - 52.13 = 55.57$ dBuV/m which is under 74dBuV/m limit.

The band edge emission plot on the next third page shows 57.82dBc between carrier maximum power and local maximum emission in restrict band (2.48780GHz). The emission of carrier strength list in the test result of channel 11 at the item 4.1.7 is 103.38dBuV/m (Average), so the maximum field strength in restrict band is $103.38 - 57.82 = 45.56$ dBuV/m which is under 54dBuV/m limit.

TEST MODE B

NOTE 1: The band edge emission plot on the next second page shows 49.93dBc between carrier maximum power and local maximum emission in restrict band (2.38900GHz). The emission of carrier strength list in the test result of channel 1 at the item 4.1.7 is 108.50dBuV/m (Peak), so the maximum field strength in restrict band is $108.50 - 49.93 = 58.57$ dBuV/m which is under 74dBuV/m limit.

The band edge emission plot on the next second page shows 57.40dBc between carrier maximum power and local maximum emission in restrict band (2.38900GHz). The emission of carrier strength list in the test result of channel 1 at the item 4.1.7 is 104.36BuV/m (Average), so the maximum field strength in restrict band is $104.36 - 57.40 = 46.96$ dBuV/m which is under 54dBuV/m limit.

NOTE 2: The band edge emission plot on the next third page shows 52.13dBc between carrier maximum power and local maximum emission in restrict band (2.48500GHz). The emission of carrier strength list in the test result of channel 11 at the item 4.1.7 is 107.61dBuV/m (Peak), so the maximum field strength in restrict band is $107.61 - 52.13 = 55.48$ dBuV/m which is under 74dBuV/m limit.

The band edge emission plot on the next forth page shows 57.82dBc between carrier maximum power and local maximum emission in restrict band (2.48780GHz). The emission of carrier strength list in the test result of channel 11 at the item 4.1.7 is 103.52dBuV/m (Average), so the maximum field strength in restrict band is $103.52 - 57.82 = 45.70$ dBuV/m which is under 54dBuV/m limit.



A D T

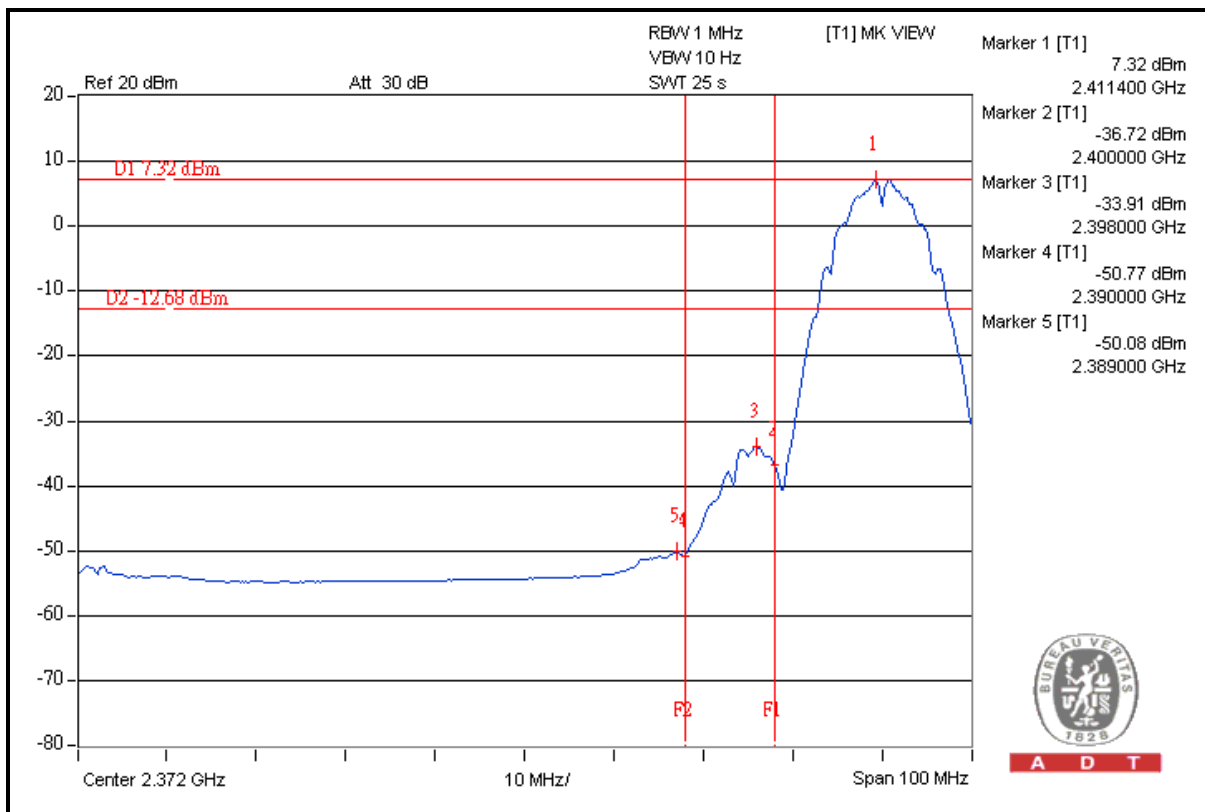
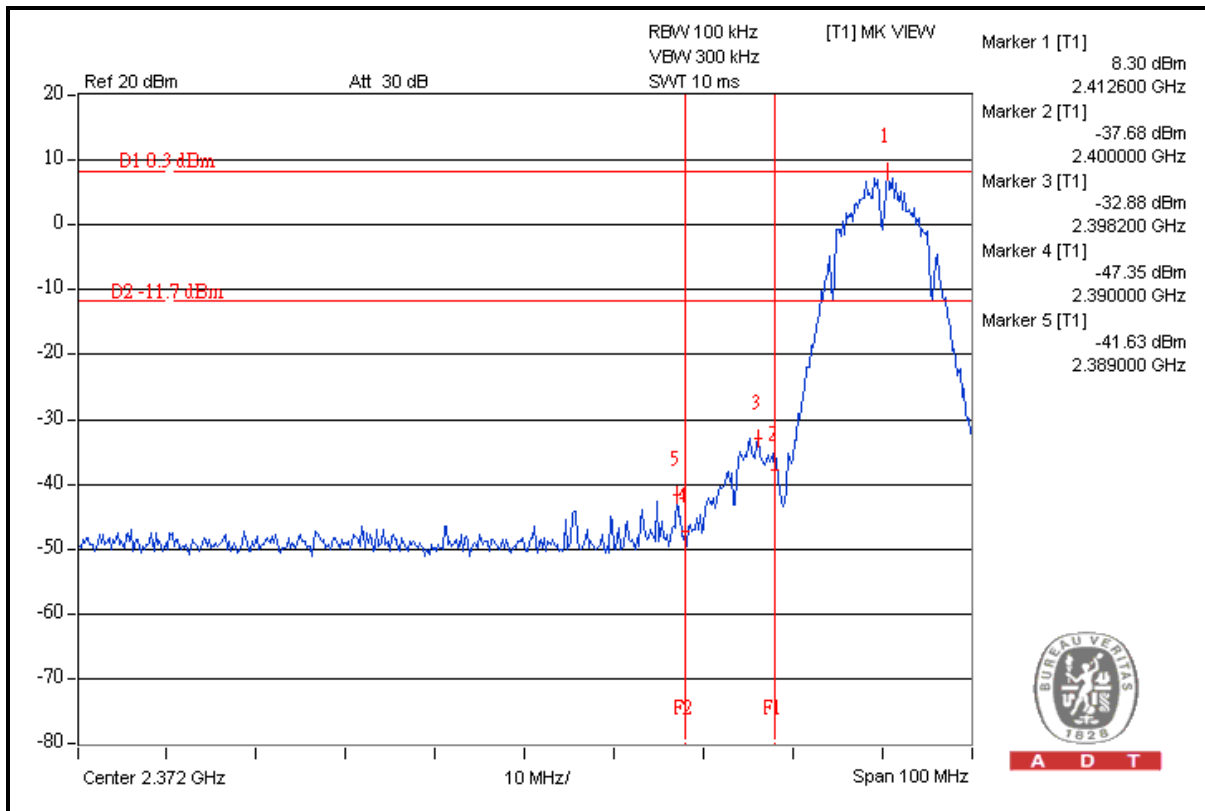



A D T

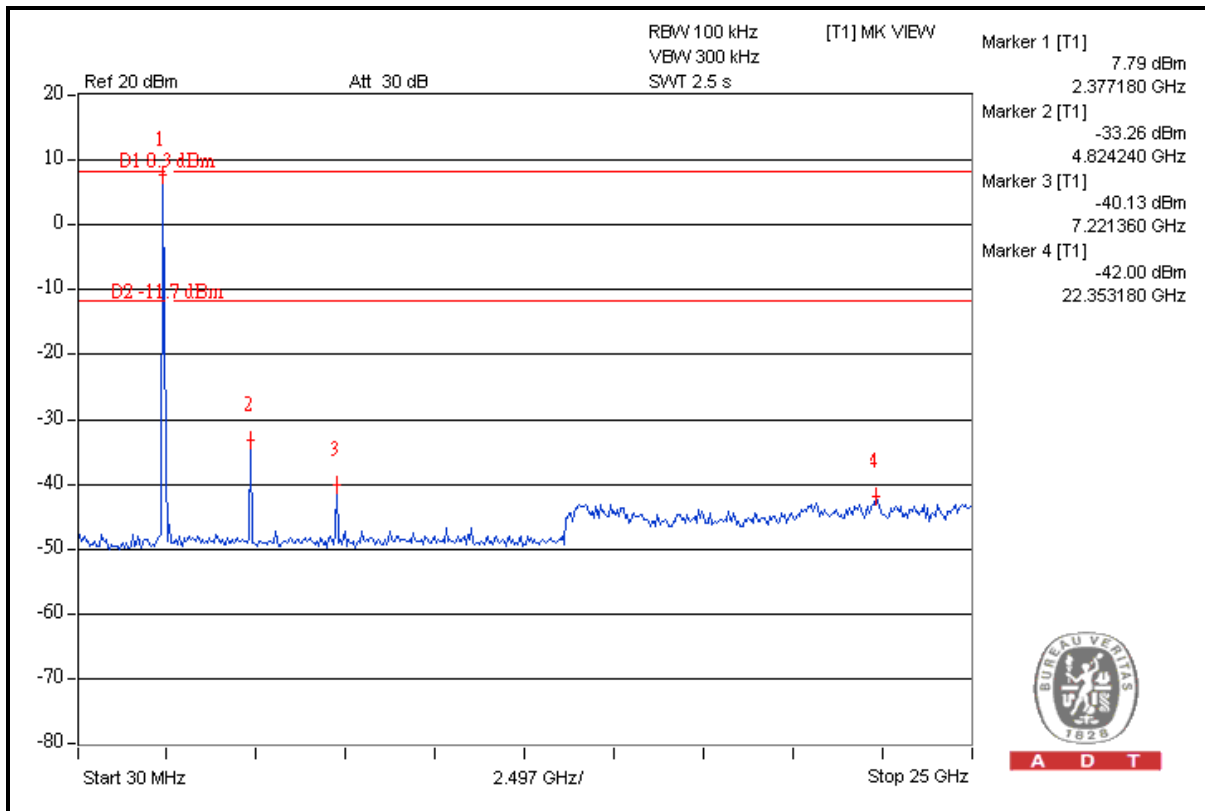

A D T

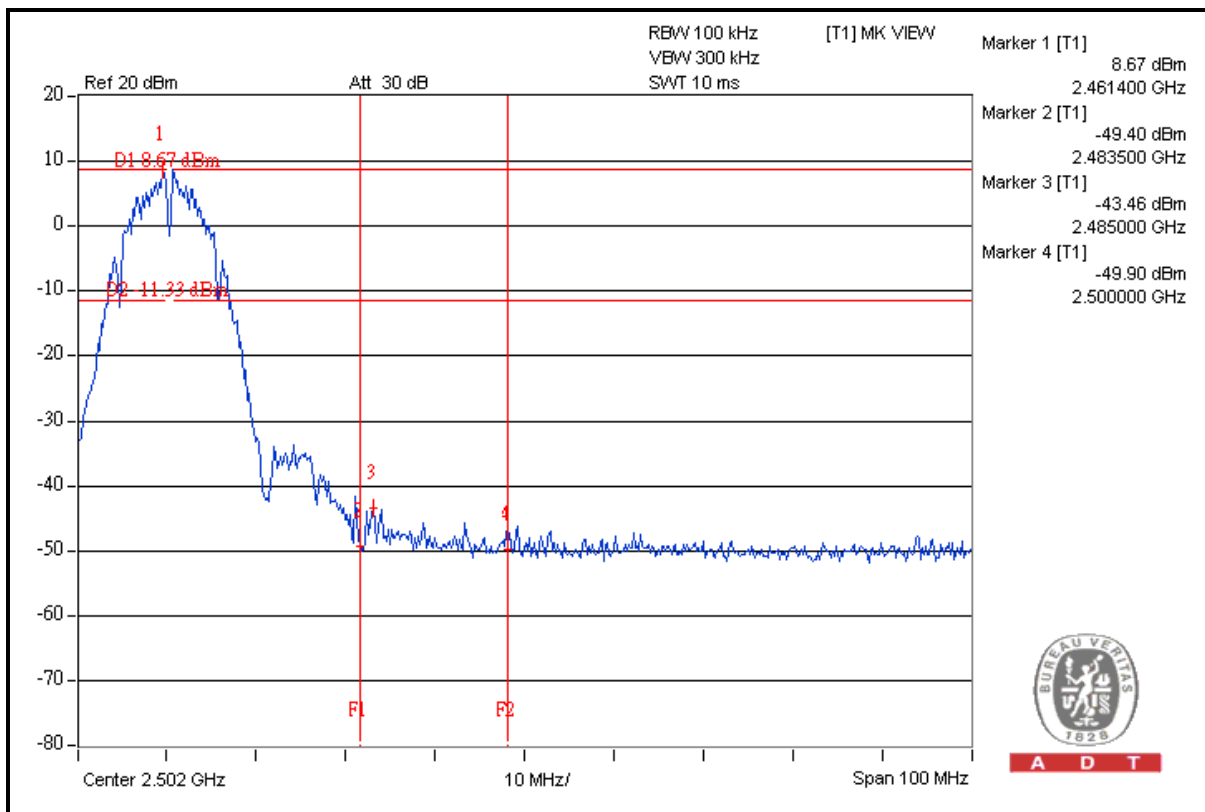

A D T



A D T

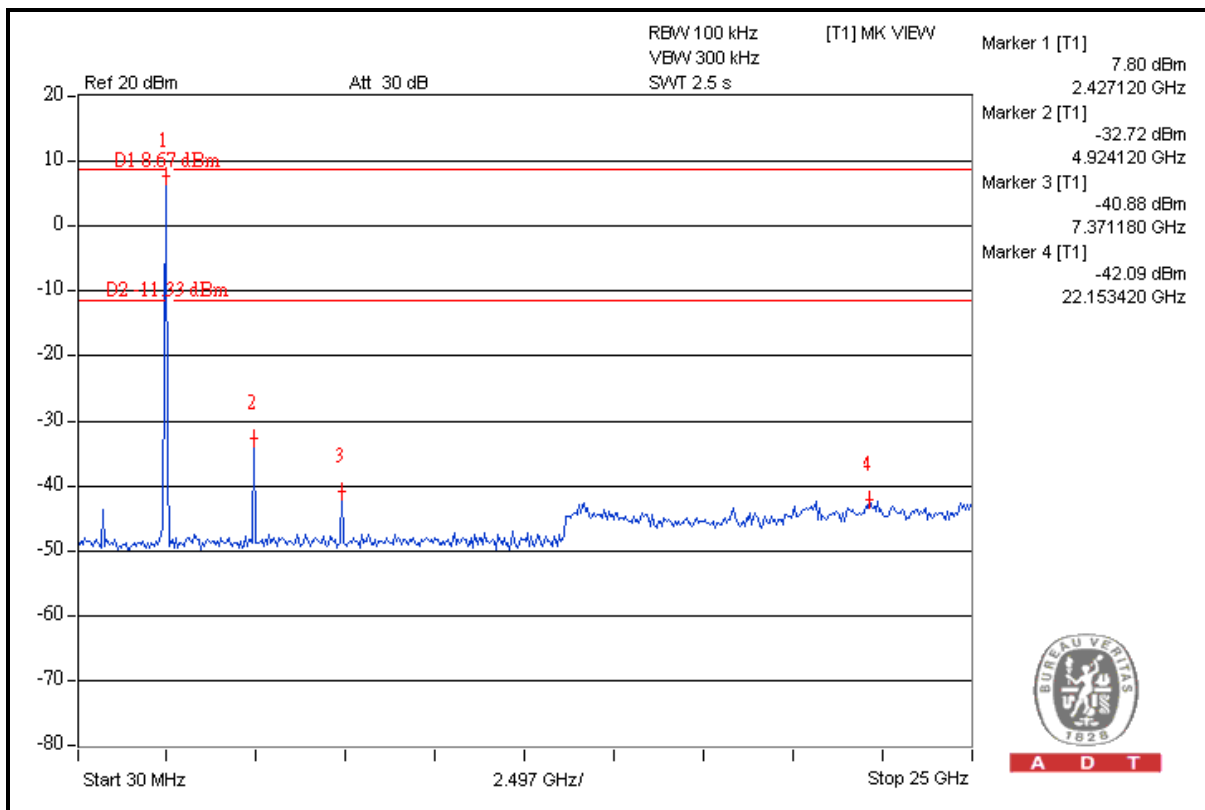
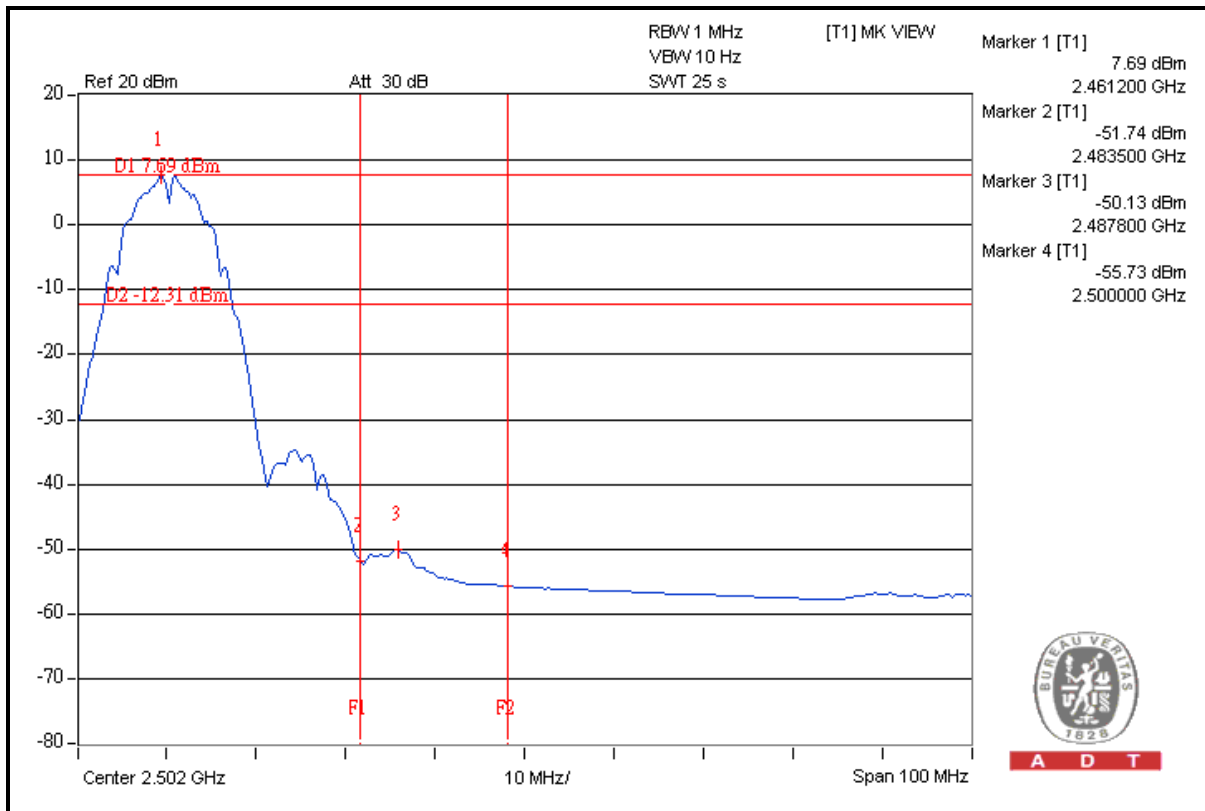

802.11g OFDM MODULATION

TEST MODE A

NOTE 1: The band edge emission plot on the next page shows 43.54dBc between carrier maximum power and local maximum emission in restrict band (2.39000GHz). The emission of carrier strength list in the test result of channel 1 at the item 4.1.7 is 105.47dBuV/m (Peak), so the maximum field strength in restrict band is $105.47 - 43.54 = 61.93$ dBuV/m which is under 74dBuV/m limit.

The band edge emission plot on the next page shows 44.63dBc between carrier maximum power and local maximum emission in restrict band (2.39000GHz). The emission of carrier strength list in the test result of channel 1 at the item 4.1.7 is 95.91dBuV/m (Average), so the maximum field strength in restrict band is $95.91 - 44.63 = 51.28$ dBuV/m which is under 54dBuV/m limit.

NOTE 2: The band edge emission plot on the next second page shows 43.44dBc between carrier maximum power and local maximum emission in restrict band (2.48360GHz). The emission of carrier strength list in the test result of channel 11 at the item 4.1.7 is 107.34dBuV/m (Peak), so the maximum field strength in restrict band is $107.34 - 43.44 = 63.90$ dBuV/m which is under 74dBuV/m limit.

The band edge emission plot on the next third page shows 44.80dBc between carrier maximum power and local maximum emission in restrict band (2.48350GHz). The emission of carrier strength list in the test result of channel 11 at the item 4.1.7 is 97.19dBuV/m (Average), so the maximum field strength in restrict band is $97.19 - 44.80 = 52.39$ dBuV/m which is under 54dBuV/m limit.

TEST MODE B

NOTE 1: The band edge emission plot on the next second page shows 43.54dBc between carrier maximum power and local maximum emission in restrict band (2.39000GHz). The emission of carrier strength list in the test result of channel 1 at the item 4.1.7 is 105.58dBuV/m (Peak), so the maximum field strength in restrict band is $105.58 - 43.54 = 62.04$ dBuV/m which is under 74dBuV/m limit.

The band edge emission plot on the next second page shows 44.63dBc between carrier maximum power and local maximum emission in restrict band (2.39000GHz). The emission of carrier strength list in the test result of channel 1 at the item 4.1.7 is 96.58dBuV/m (Average), so the maximum field strength in restrict band is $96.58 - 44.63 = 51.95$ dBuV/m which is under 54dBuV/m limit.

NOTE 2: The band edge emission plot on the next third second page shows 43.44dBc between carrier maximum power and local maximum emission in restrict band (2.48360GHz). The emission of carrier strength list in the test result of channel 11 at the item 4.1.7 is 105.76dBuV/m (Peak), so the maximum field strength in restrict band is $105.76 - 43.44 = 62.32$ dBuV/m which is under 74dBuV/m limit.

The band edge emission plot on the next forth page shows 44.80dBc between carrier maximum power and local maximum emission in restrict band (2.48350GHz). The emission of carrier strength list in the test result of channel 11 at the item 4.1.7 is 96.61dBuV/m (Average), so the maximum field strength in restrict band is $96.61 - 44.80 = 51.81$ dBuV/m which is under 54dBuV/m limit.



A D T

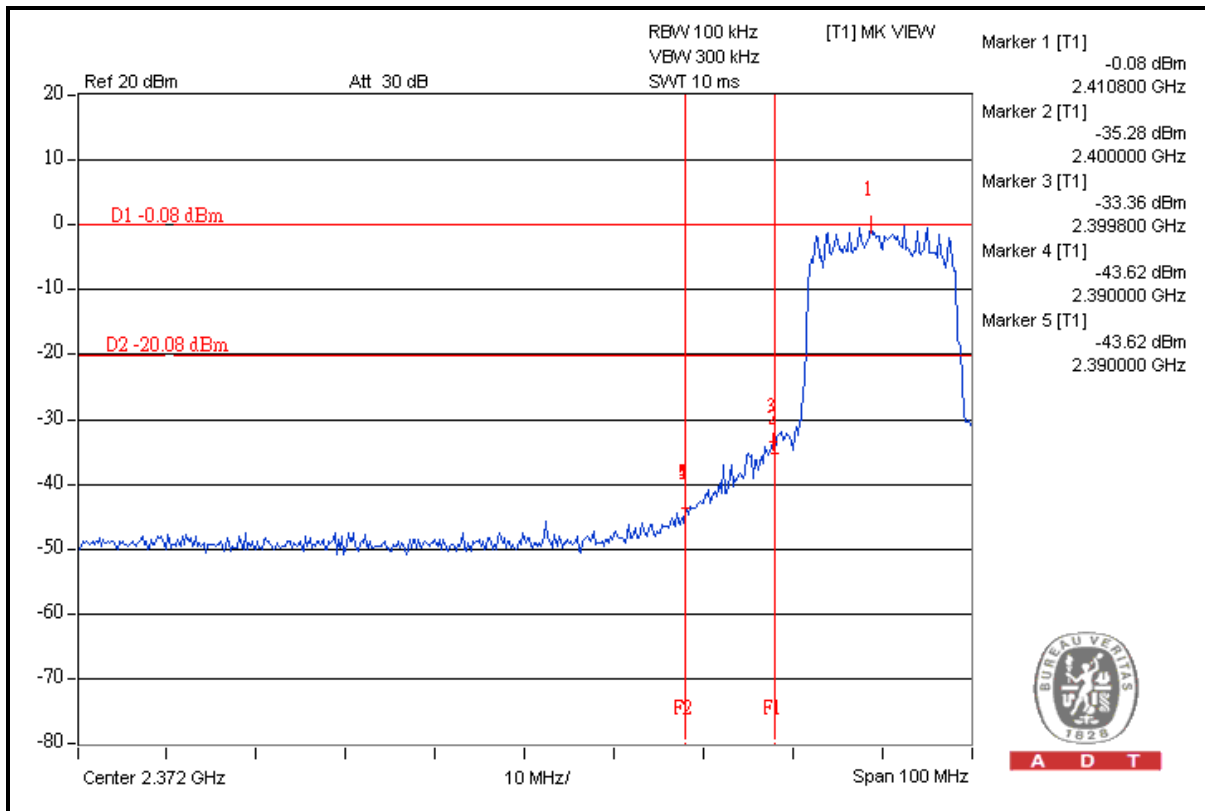

A D T

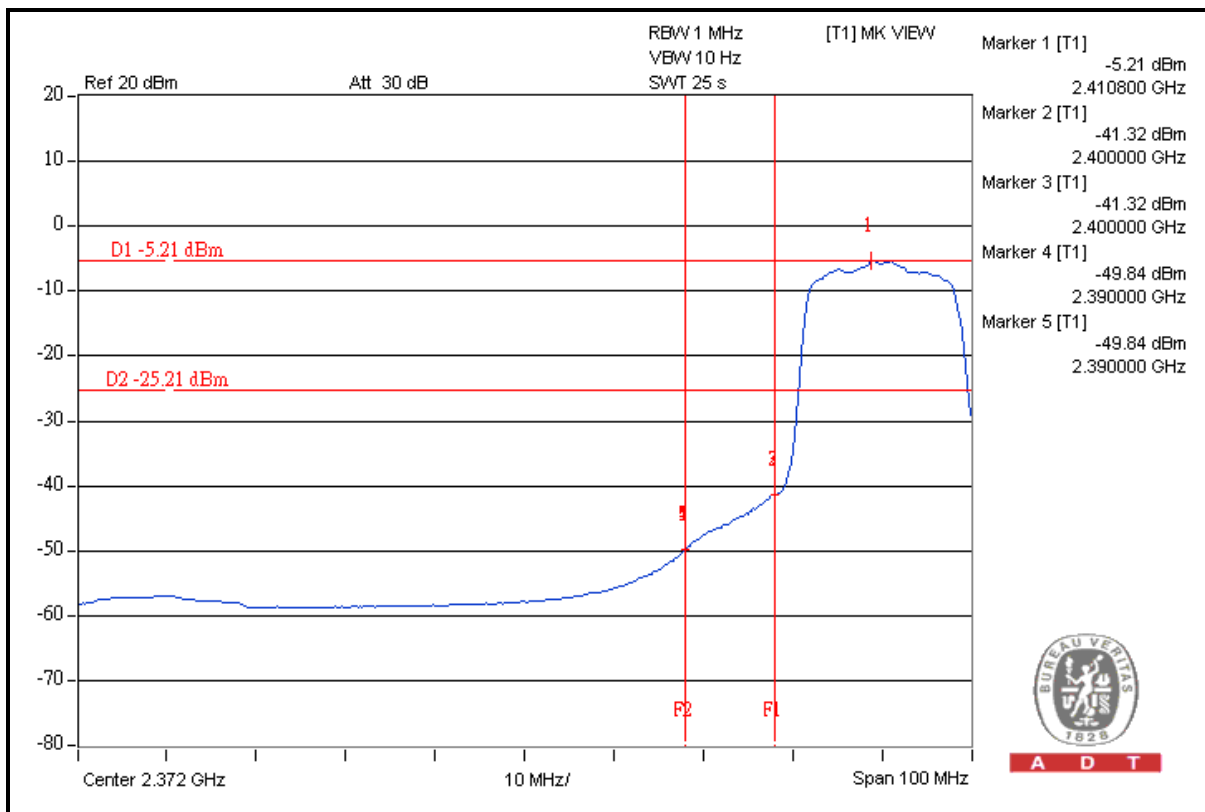

A D T



A D T

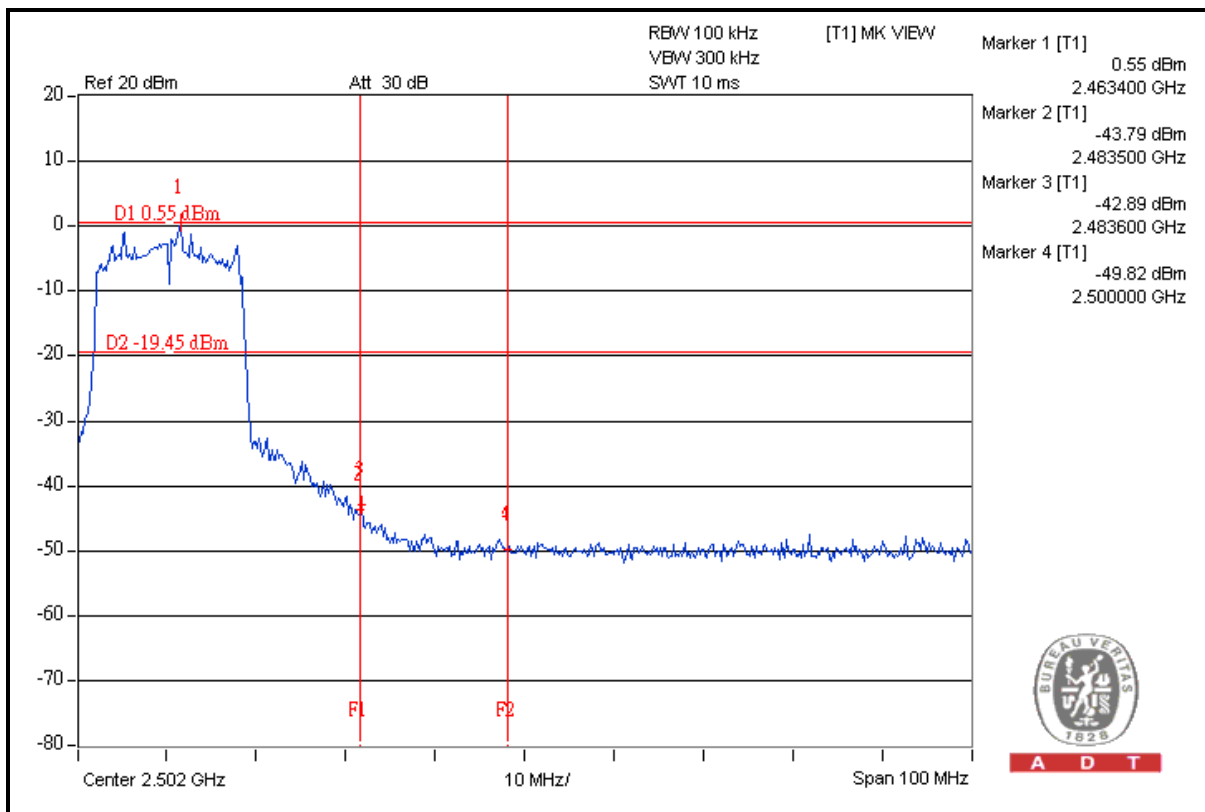
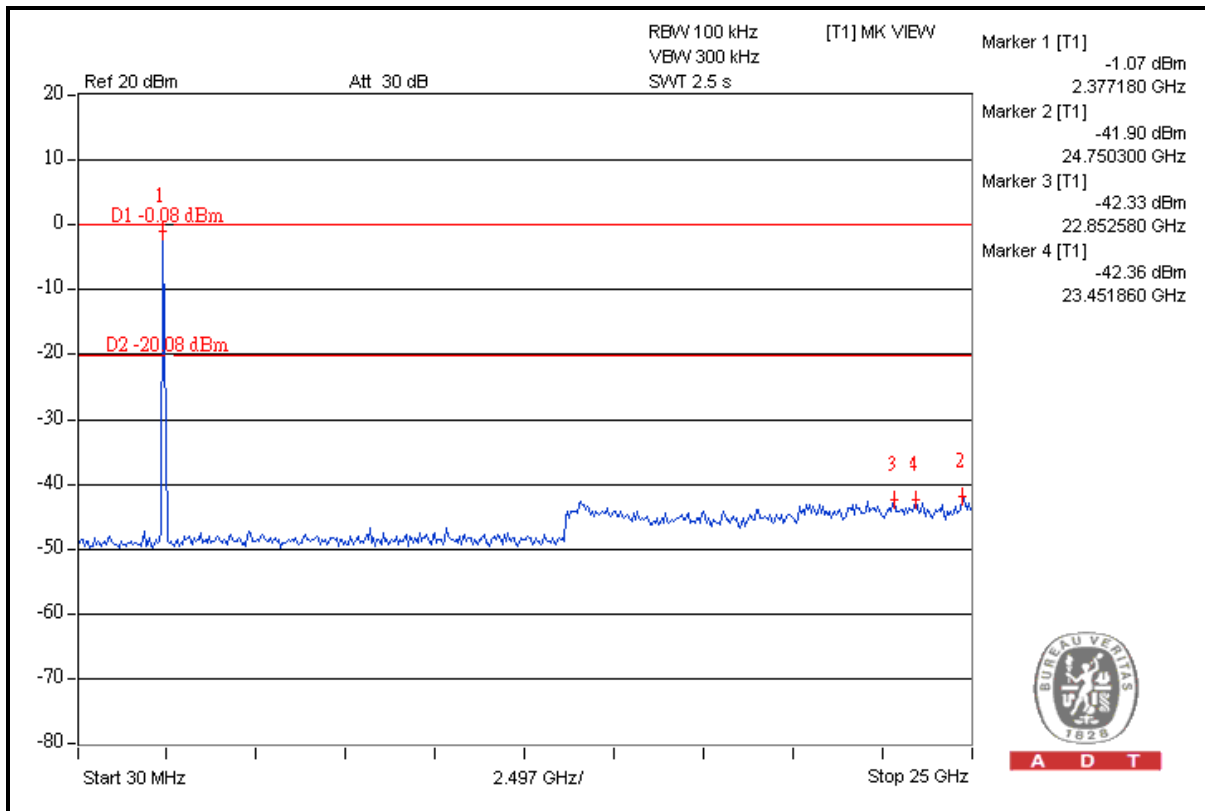



A D T

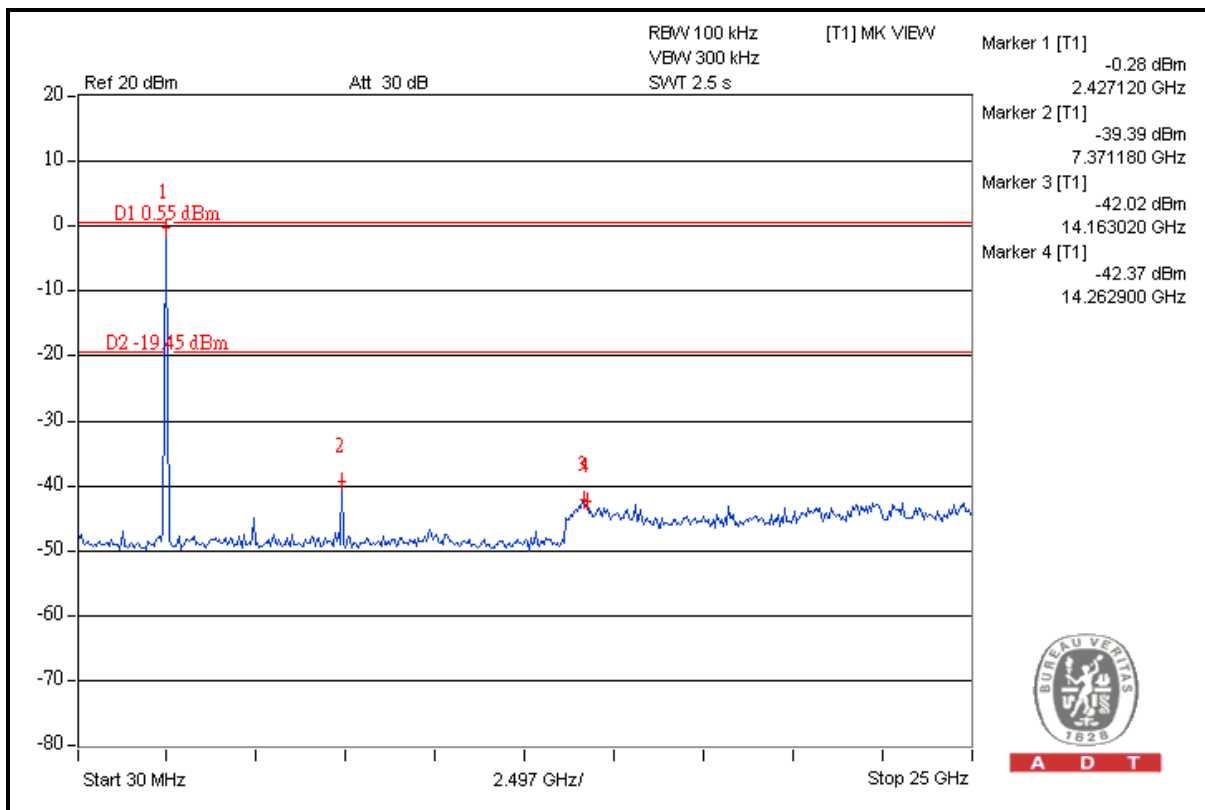
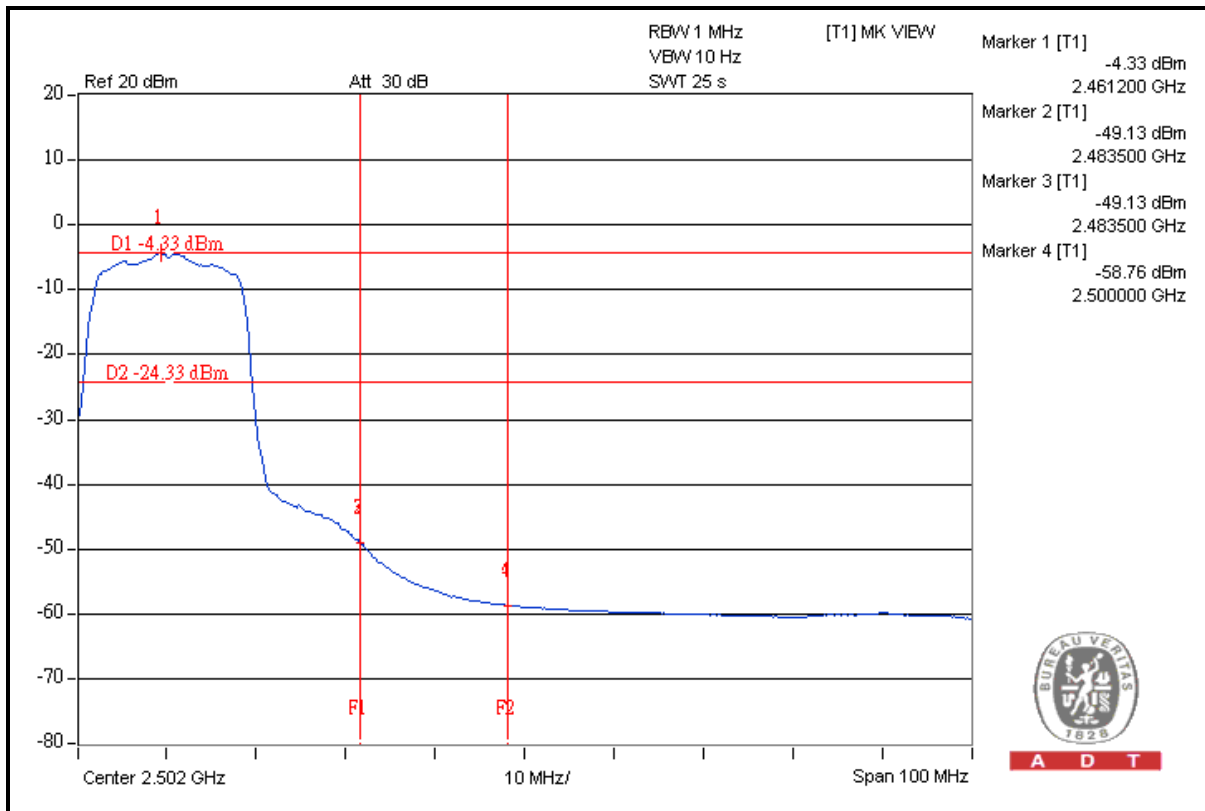

4.6 ANTENNA REQUIREMENT

4.6.1 STANDARD APPLICABLE

For intentional device, according to FCC 47 CFR Section 15.203, an intentional radiator shall be designed to ensure that no antenna other than that furnished by the responsible party shall be used with the device. And according to FCC 47 CFR Section 15.247 (b), if transmitting antennas of directional gain greater than 6dBi are used, the power shall be reduced by the amount in dB that the directional gain of the antenna exceeds 6dBi.

4.6.2 ANTENNA CONNECTED CONSTRUCTION

The antennas used in this product are PIFA antenna and Printed antenna without antenna connector. The maximum gain of the antenna is 1.89dBi.

5. PHOTOGRAPHS OF THE TEST CONFIGURATION

Please refer to the attached file (Test Setup Photo).

6. INFORMATION ON THE TESTING LABORATORIES

We, Bureau Veritas Consumer Products Services (H.K.) Ltd., Taoyuan Branch, were founded in 1988 to provide our best service in EMC, Radio, Telecom and Safety consultation. Our laboratories are accredited and approved by the following approval agencies according to ISO/IEC 17025.

USA	FCC, NVLAP
Germany	TUV Rheinland
Japan	VCCI
Norway	NEMKO
Canada	INDUSTRY CANADA , CSA
R.O.C.	TAF, BSMI, NCC
Netherlands	Telefication
Singapore	GOST-ASIA(MOU)
Russia	CERTIS(MOU)

Copies of accreditation certificates of our laboratories obtained from approval agencies can be downloaded from our web site:

www.adt.com.tw/index.5/phtml. If you have any comments, please feel free to contact us at the following:

Linko EMC/RF Lab:

Tel: 886-2-26052180

Fax: 886-2-26051924

Hsin Chu EMC/RF Lab:

Tel: 886-3-5935343

Fax: 886-3-5935342

Hwa Ya EMC/RF/Safety Telecom Lab:

Tel: 886-3-3183232

Fax: 886-3-3185050

Web Site: www.adt.com.tw

The address and road map of all our labs can be found in our web site also.

7. APPENDIX A - MODIFICATIONS RECORDERS FOR ENGINEERING CHANGES TO THE EUT BY THE LAB

No any modifications are made to the EUT by the lab during the test.

--- END ---