

FCC Part 15, Subpart C Test Report

FCC ID: XN6-SV510M86

Applicant: Zylux Acoustic Corporation

Address: 7F, 70, Rui Guang Road, Neihu District, Taipei 114, Taiwan, Chinese Taipei

Manufacturer: VIZIO INC.

Address: 39 Tesla, Irvine, CA 92618, USA

Product(s): VIZIO 5.1 Soundbar

Brand(s): **VIZIO**

Test Model(s): SV510M-0806

Series Model(s): SV510X-0806

Test Date: Aug. 12, 2023 ~ Nov. 07, 2023

Issued Date: Nov. 08, 2023

Issued By: Hwa-Hsing (Dongguan) Testing Co., Ltd.

Address: No.101, Building N1, Yuyuan 2 Road, Yuyuan Industrial Park, HuangJiang Town, Dongguan City, People's Republic of China

Test Firm Registration No.: 915896

Designation No.: CN1255

Standards: 47 CFR FCC Part 15, Subpart C (Section 15.247)
ANSI C63.10:2013

The above equipment has been tested by **Hwa-Hsing (Dongguan) Testing Co., Ltd.**, and found compliance with the requirement of the above standards. The test record, data evaluation & Equipment Under Test (EUT) configurations represented herein are true and accurate accounts of the measurements of the sample's EMC characteristics under the conditions specified in this report.

Prepared by :



Nature Lee

Reviewed by :



Andy Yeh

Approved by :



Scott He

"This report is for your exclusive use. Any copying or replication of this report to or for any other person or entity, or use of our name or trademark, is permitted only with our prior written permission. This report sets forth our findings solely with respect to the test samples identified herein. Our report includes all the tests requested by you and the results thereof based upon the information that you provided to us. The report would be invalid without specific stamp of test institute and the signatures of tester and approver."

Lab: [Hwa-Hsing \(Dongguan\) Testing Co., Ltd.](#)

Address: [No.101, Building N1, Yuyuan 2 Road, Yuyuan Industrial Park, HuangJiang Town, Dongguan City, People's Republic of China](#)

Tel: [0769-83078199](tel:0769-83078199)

Web.: www.hwa-hsing.com

E-Mail: customerservice.dg@hwa-hsing.com

Release

[Ver. 1.5](#)



Table of Contents

- Release Control Record 4**
- 1 Summary of Test Results 5**
 - 1.1 Measurement Uncertainty 5
 - 1.2 Modification Record 5
- 2 General Information 6**
 - 2.1 General Description of EUT 6
 - 2.2 Description of Test Modes 7
 - 2.3 Test Mode Applicability and Tested Channel Detail 8
 - 2.4 Description of Support Units 10
 - 2.5 Configuration of System under Test 11
 - 2.6 Duty Cycle of Test Signal 12
- 3 Test Types and Results 13**
 - 3.1 Radiated Emission and Band-edge Measurement 13
 - 3.1.1 Limits of Radiated Emission and Band-edge Measurement 13
 - 3.1.2 Test Instruments 14
 - 3.1.3 Test Procedures 15
 - 3.1.4 Deviation from Test Standard 16
 - 3.1.5 Test Setup 17
 - 3.1.6 EUT Operating Conditions 18
 - 3.1.7 Test Results 19
 - 3.2 Conducted emission measurement 39
 - 3.2.1 Limits of Conducted Emission Measurement 39
 - 3.2.2 Test Instruments 39
 - 3.2.3 Test Procedures 40
 - 3.2.4 Test Setup 40
 - 3.2.5 EUT Operating Condition 40
 - 3.2.6 Deviation from Test Standard 40
 - 3.2.7 Test Results 41
 - 3.3 Number of Hopping Frequency Used 43
 - 3.3.1 Limits of Hopping Frequency Used Measurement 43
 - 3.3.2 Test Setup 43
 - 3.3.3 Test Instruments 43
 - 3.3.4 Test Procedure 43
 - 3.3.5 Deviation from Test Standard 43
 - 3.3.6 Test Results 44
 - 3.4 Dwell Time on Each Channel 45
 - 3.4.1 Limits of Dwell Time on Each Channel Measurement 45
 - 3.4.2 Test Setup 45
 - 3.4.3 Test Instruments 45
 - 3.4.4 Test Procedures 45
 - 3.4.5 Deviation from Test Standard 45
 - 3.4.6 Test Results 46
 - 3.5 Channel Bandwidth 49
 - 3.5.1 Limits of Channel Bandwidth Measurement 49
 - 3.5.2 Test Setup 49
 - 3.5.3 Test Instruments 49
 - 3.5.4 Test Procedure 49
 - 3.5.5 Deviation from Test Standard 49
 - 3.5.6 EUT Operating Condition 49

Lab: [Hwa-Hsing \(Dongguan\) Testing Co., Ltd.](#)

Address: [No.101, Building N1, Yuyuan 2 Road, Yuyuan Industrial Park, HuangJiang Town, Dongguan City, People's Republic of China](#)

Tel: [0769-83078199](tel:0769-83078199)

Web.: www.hwa-hsing.com

E-Mail: customerservice.dg@hwa-hsing.com

Release

[Ver. 1.5](#)



3.5.7 Test Results	50
3.6 Occupied Bandwidth Measurement	52
3.6.1 Test Setup	52
3.6.2 Test Instruments	52
3.6.3 Test Procedure	52
3.6.4 Deviation from Test Standard	52
3.6.5 EUT Operating Conditions	52
3.6.6 Test Results	53
3.7 Hopping Channel Separation	55
3.7.1 Limits of Hopping Channel Separation Measurement	55
3.7.2 Test Setup	55
3.7.3 Test Instruments	55
3.7.4 Test Procedure	55
3.7.5 Deviation from Test Standard	55
3.7.6 Test Results	56
3.8 Maximum Output Power	58
3.8.1 Limits of Maximum Output Power Measurement	58
3.8.2 Test Setup	58
3.8.3 Test Instruments	58
3.8.4 Test Procedure	58
3.8.5 Deviation from Test Standard	60
3.8.6 EUT Operating Condition	60
3.8.7 Test Results	61
3.9 Conducted Out of Band Emission Measurement	64
3.9.1 Limits of Conducted Out of Band Emission Measurement	64
3.9.2 Test Setup	64
3.9.3 Test Instruments	64
3.9.4 Test Procedure	65
3.9.5 Deviation from Test Standard	65
3.9.6 EUT Operating Condition	65
3.9.7 Test Results	66
4 Pictures of Test Arrangements	71
5 Test Instruments	72
Appendix – Information on the Testing Laboratories	73



Release Control Record

Issue No.	Description	Date Issued
230505KH05-RF-US-01	Original Release	Nov. 08, 2023



1 Summary of Test Results

47 CFR FCC Part 15, Subpart C (Section 15.247) KDB 558074 D01 15.247 Meas Guidance v05r02 ANSI C63.10:2013;			
FCC Clause	Test Item	Result	Remarks
15.247(a)(1) (iii)	Number of Hopping Frequency Used	Pass	Meet the requirement of limit.
15.247(a)(1) (iii)	Dwell Time on Each Channel	Pass	Meet the requirement of limit.
15.247(a)(1)	1. Hopping Channel Separation 2. Spectrum Bandwidth of a Frequency Hopping Sequence Spread Spectrum System	Pass	Meet the requirement of limit.
15.247(b)	Maximum Peak Output Power	Pass	Meet the requirement of limit.
---	Occupied Bandwidth Measurement	Pass	Reference only
15.205 & 209	Radiated Emissions	Pass	Meet the requirement of limit.
15.247(d)	Band Edge Measurement	Pass	Meet the requirement of limit.
15.247(d)	Antenna Port Emission	Pass	Meet the requirement of limit.
15.203	Antenna Requirement	Pass	No antenna connector is used.

Note1: If the Frequency Hopping System operating in 2400-2483.5MHz band and the output power less than 125mW. The hopping channel carrier frequencies separated by a minimum of 25kHz or two-thirds of the 20dB bandwidth of hopping channel whichever is greater.

Note2: The EUT has been verified to comply with the requirements of FCC Part 15, Subpart B, Class B (sDoC). The test report has been issued separately.

1.1 Measurement Uncertainty

Where relevant, the following measurement uncertainty levels have been estimated for tests performed on the EUTas specified in CISPR 16-4-2:

The listed uncertainties are the worst-case uncertainty for the entire range of measurement. Please note that the uncertainty values are provided for informational purposes only and are not used in determining the PASS/FAIL results.

Measurement	Frequency	Expanded Uncertainty (k=2) (±)
Radiated Emissions up to 1 GHz	9KHz ~ 30MHz	2.16 dB
	30MHz ~ 1000MHz	3.47 dB
Radiated Emissions above 1 GHz	1GHz ~ 18GHz	4.84 dB
	18GHz ~ 40GHz	4.67 dB

Note: This uncertainty represents an expanded uncertainty expressed at approximately the 95% confidence level using a coverage factor of k = 2.

1.2 Modification Record

There were no modifications required for compliance.



2 General Information

2.1 General Description of EUT

Product(s)	VIZIO 5.1 Soundbar
Test Model(s)	SV510M-0806
Sample No.	N/A
Series Model(s)	SV510X-0806
Status of EUT	Engineering Prototype
Power Supply Rating	100-240 V~ 50/60 Hz 75 W
Modulation Type	GFSK, $\pi/4$ DQPSK, 8DPSK for FHSS
Transfer Rate	1Mbps, 2Mbps, 3Mbps
Operating Frequency	2402 ~ 2480MHz
Number of Channel	79
Output Power (Peak)	8.20dBm
Antenna Type	Dipole Antenna
Antenna Gain	2.75dBi
Antenna Connector	N/A
Accessory Device	N/A

Note:

1. Please refer to the EUT photo document (Reference No.: 230505KH05-01&02) for detailed product photo.
2. The above EUT information is declared by manufacturer and for more detailed features description, please refer to the manufacturer's specifications or User's Manual.
3. Model difference: These models are the same except model name.
4. The EUT is tested on all items, and the report only shows the worst data.



2.2 Description of Test Modes

79 channels are provided to this EUT:

Channel	Freq. (MHz)	Channel	Freq. (MHz)	Channel	Freq. (MHz)	Channel	Freq. (MHz)
0	2402	20	2422	40	2442	60	2462
1	2403	21	2423	41	2443	61	2463
2	2404	22	2424	42	2444	62	2464
3	2405	23	2425	43	2445	63	2465
4	2406	24	2426	44	2446	64	2466
5	2407	25	2427	45	2447	65	2467
6	2408	26	2428	46	2448	66	2468
7	2409	27	2429	47	2449	67	2469
8	2410	28	2430	48	2450	68	2470
9	2411	29	2431	49	2451	69	2471
10	2412	30	2432	50	2452	70	2472
11	2413	31	2433	51	2453	71	2473
12	2414	32	2434	52	2454	72	2474
13	2415	33	2435	53	2455	73	2475
14	2416	34	2436	54	2456	74	2476
15	2417	35	2437	55	2457	75	2477
16	2418	36	2438	56	2458	76	2478
17	2419	37	2439	57	2459	77	2479
18	2420	38	2440	58	2460	78	2480
19	2421	39	2441	59	2461	-	-



2.3 Test Mode Applicability and Tested Channel Detail

EUT Configure Mode	Applicable test items	X-Axis	Y-Axis	Z-Axis	Voltage Supply
Conducted	AC Power Conducted Emission	N/A	N/A	N/A	AC120V/60Hz
Radiated	Radiated Emissions	√	√	√	
Antenna Port Conducted Measurement	Number of Hopping Frequency Used	N/A	N/A	N/A	
	Dwell Time on Each Channel	N/A	N/A	N/A	
	Band Edge Measurement	N/A	N/A	N/A	
	Antenna Port Emission	N/A	N/A	N/A	
	Conducted power	N/A	N/A	N/A	
	Hopping Channel Separation	N/A	N/A	N/A	
	Spectrum Bandwidth of a Frequency Hopping Sequence Spread Spectrum System	N/A	N/A	N/A	

- *: The EUT had been pre-tested on the positioned of each 3 Axis. The worst case was found when positioned on **X-plane**.
- “N/A” means no effect.

Evaluation of difference data rate:

Applicable test items	Modulation Type			The Worst-case modes recording in report
	GFSK	π/4DQPSK	8DPSK	
Radiated Emissions	√	√	√	GFSK& 8DPSK
Antenna Port Conducted Measurement	√	√	√	GFSK& 8DPSK

Test Condition:

Applicable test items	Environmental Conditions	Test Date	Tested by
Radiated Emissions	26.8deg. C, 58%RH	Aug. 21, 2023	Hua
Antenna Port Conducted Measurement	26.2deg. C, 51%RH	Aug. 24, 2023	Hua

- Pre-Scan has been conducted to determine the worst-case mode from all possible combinations between available modulations, data rates and antenna ports (if EUT with antenna diversity architecture). Following channel(s) was (were) selected for the final test as listed below.



Radiated Emission Test (Above 1 GHz):

EUT Configure Mode	Available Channel	Tested Channel	Modulation Technology	Modulation Type	Packet Type
-	0 to 78	0, 39, 78	FHSS	GFSK	DH5
-	0 to 78	0, 39, 78	FHSS	8DPSK	3DH5

Radiated Emission Test (Below 1 GHz):

EUT Configure Mode	Available Channel	Tested Channel	Modulation Technology	Modulation Type	Packet Type
-	0 to 78	0	FHSS	GFSK	DH5
-	0 to 78	0	FHSS	8DPSK	3DH5

Power Line Conducted Emission Test:

EUT Configure Mode	Available Channel	Tested Channel	Modulation Technology	Modulation Type	Packet Type
-	0 to 78	39	FHSS	GFSK	DH5

Antenna Port Conducted Measurement:

This item includes all test value of each mode, but only includes spectrum plot of worst value of each mode.

EUT Configure Mode	Available Channel	Tested Channel	Modulation Technology	Modulation Type	Packet Type
-	0 to 78	0, 39, 78	FHSS	GFSK	DH5
-	0 to 78	0, 39, 78	FHSS	8DPSK	3DH5



2.4 Description of Support Units

The EUT has been tested as an independent unit together with other necessary accessories or support units. The following support units or accessories were used to form a representative test configuration during the tests.

No.	Product	Brand	Model No.	Serial No.	FCC ID
1	Notebook	HUAWEI	NbD-WFH9	EUEPM21725002655	N/A

No.	Signal Cable Description of The Above Support Units
1	USB extension cord: Unshielded, Detachable 1.2m;



2.5 Configuration of System under Test

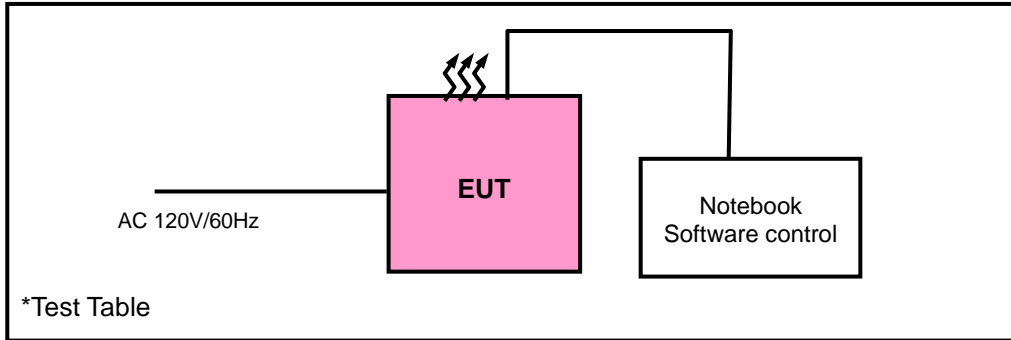



2.6 Duty Cycle of Test Signal

Test Mode	Channel	Duty Cycle [%]
DH5	2402	76.53
	2441	76.33
	2480	76.53

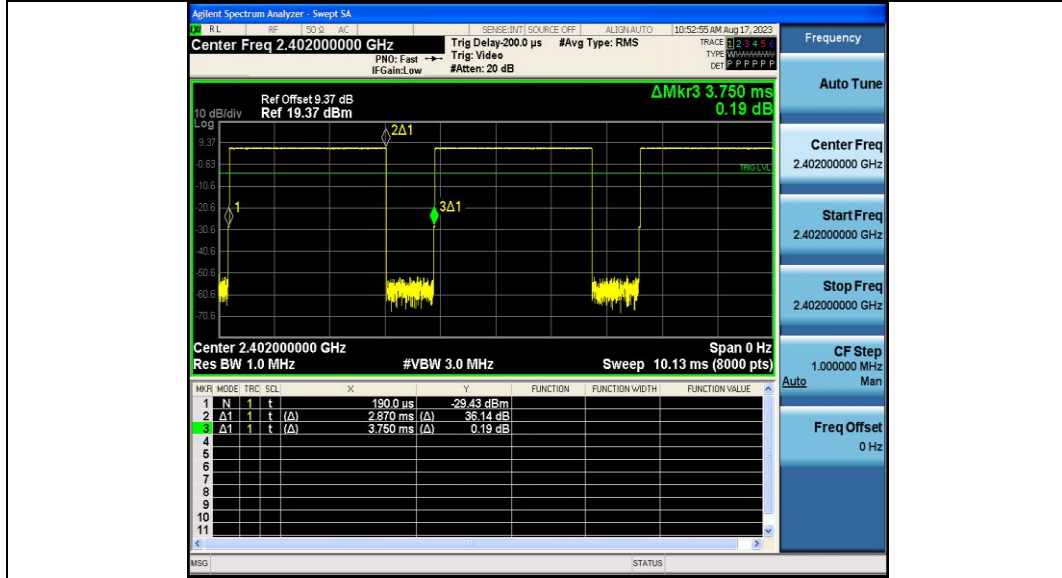

Test Mode	Channel	Duty Cycle [%]
3DH5	2402	76.80
	2441	76.80
	2480	76.80

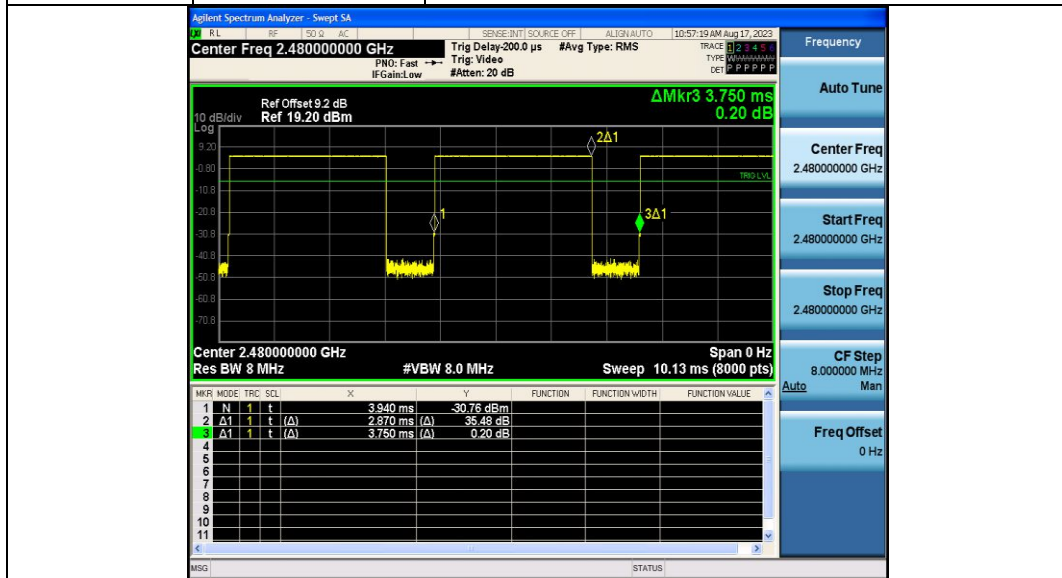



3 Test Types and Results

3.1 Radiated Emission and Band-edge Measurement

3.1.1 Limits of Radiated Emission and Band-edge Measurement

Radiated emissions which fall in the restricted bands must comply with the radiated emission limits specified as below table. Other emissions shall be at least 20 dB below the highest level of the desired power:

Frequencies (MHz)	Field Strength (microvolts/meter)	Measurement Distance (meters)
0.009 ~ 0.490	2400/F(kHz)	300
0.490 ~ 1.705	24000/F(kHz)	30
1.705 ~ 30.0	30	30
30 ~ 88	100	3
88 ~ 216	150	3
216 ~ 960	200	3
Above 960	500	3

* DTS emissions in non-restricted frequency bands Subclause 11.11 of ANSI C63.10 is applicable.

* DTS emissions in restricted frequency bands Subclause 11.12 of ANSI C63.10 is applicable

Note:

1. The lower limit shall apply at the transition frequencies.
2. Emission level (dBuV/m) = 20 log Emission level (uV/m).
3. For frequencies above 1000 MHz, the field strength limits are based on average detector, however, the peak field strength of any emission shall not exceed the maximum permitted average limits, specified above by more than 20 dB under any condition of modulation.



3.1.2 Test Instruments

Radiated emission below 30MHz:

Equipment	Manufacturer	Model No.	Serial No.	Next Cal.
EMI Test Receiver	Rohde&Schwarz	ESR7	100962	2023-12-27
3m Semi-anechoic Chamber	MAORUI	9m*6m*6m	NSEMC003	2026-03-12**
Test software	FARAD	FARAD	EZ_EMCV1.1.4.2	N/A
Loop Antenna	EMCI	HLA 6121	56735	2024-05-04*
Antenna Tower	MF	MFA-440H	NA	NA
Turn Table	MF	MFT-201SS	NA	NA
Antenna Tower&Turn Table Controller	MF	MF-7802	NA	NA

Frequency Range below 1GHz:

Equipment	Manufacturer	Model No.	Serial No.	Next Cal.
3m Semi-anechoic Chamber	MAORUI	9m*6m*6m	NSEMC003	2026-03-12**
EMI Test Receiver	Rohde&Schwarz	ESPI 7	101978	2023-12-27
Broadband antenna	Schwarzbeck	VULB 9168	00937	2023-09-12*
Signal Amplifier	Com-power	PAM-103	18020051	2024-08-06
Attenuator	Rohde&Schwarz	TS2GA-6dB	18101101	N/A
Test software	FARAD	FARAD	EZ_EMCV1.1.4.2	N/A

Frequency Range above 1GHz:

Equipment	Manufacturer	Model No.	Serial No.	Next Cal.
3m Semi-anechoic Chamber	MAORUI	9m*6m*6m	NSEMC003	2026-03-12**
Horn Antenna	Schwarzbeck	BBHA 9120D	02202	2024-08-27*
Broadband Coaxial Pre-amplifier	Com-power	PAM-118A	1804003	2024-08-06
Spectrum	Keysight	N9020A	MY51240612	2024-08-06
Pre-Amplifier	EMCI	EMC 184045SE	9870709	2023-12-27
Antenna Tower	MF	MFA-440H	NA	NA
Turn Table	MF	MFT-201SS	NA	NA
Antenna Tower&Turn Table Controller	MF	MF-7802	NA	NA

Note:

1. The calibration interval of the above test instruments is 12 months or 24 months (*) or 36 months (**).
2. The test was performed in 966.



3.1.3 Test Procedures

a. **Peak emission levels are measured by setting the instrument as follow:**

1) RBW&VBWsetting as a function of frequency:

Frequency	RBW	VBW
9kHz~150kHz	200Hz	600Hz
0.15MHz~30MHz	9kHz	30kHz
30MHz~1000MHz	120kHz	300kHz
>1000MHz	1MHz	3MHz

- 2) Detector = peak.
- 3) Sweep time = auto.
- 4) Trace mode = max hold.
- 5) Allow sweeps to continue until the trace stabilizes. (Note that the required measurement time may be lengthened for low-duty-cycle applications.)

Note: If the peak-detected amplitude can be shown to comply with the average limit, then it is not necessary to perform a separate average measurement

b. **Average emission levels are measured by setting the instrument as follow:**

● **Trace averaging with continuous EUT transmission at full power**

If the EUT can be configured or modified to transmit continuously (D ≥ 98%), then the average emission levels shall be measured using the following method (with EUT transmitting continuously):

- 1) RBW=1 MHz (unless otherwise specified).
- 2) VBW ≥ 3 *RBW.
- 3) Detector =RMS
- 4) Sweep time = auto.
- 5) Perform a trace average of at least 100 traces.

● **Trace averaging across ON and OFF times of the EUT transmissions followed by duty cycle correction**

If continuous transmission of the EUT (D≥98%) cannot be achieved and the duty cycle is constant (duty cycle variations are less than ±2%). then the following procedure shall be used

- 1) The EUT shall be configured to operate at the maximum achievable duty cycle.
- 2) Measure the duty cycle D of the transmitter output signal as described in 11.6.
- 3) RBW=1 MHz (unless otherwise specified).
- 4) VBW ≥ 3 *RBW.
- 5) Detector =RMS
- 6) Sweep time = auto.
- 7) Perform a trace average of at least 100 traces.

A correction factor shall be added to the measurement results prior to comparing with the emission limit to compute the emission level that would have been measured had the test been performed at 100% duty cycle. The correction factor is computed as follows:

*If power averaging (rms) mode was used in step 5). then the applicable correction factor is [10 10g (1/ D)], where D is the duty cycle.

**If linear voltage averaging mode was used in step f). then the applicable correction factor is [20 10g (1/D)], where D is the duty cycle.

***If a specific emission is demonstrated to be continuous (D > 98%) rather than turning ON and OFF with the transmit cycle, then no duty cycle correction is required for that



● **Reduced VBW Averaging across ON and OFF times of the EUT transmissions with max hold**

If continuous transmission of the EUT ($D > 98\%$) cannot be achieved and the duty cycle is not constant (duty cycle variations exceed $\pm 2\%$), then the following procedure shall be used:

- 1) RBW = 1 MHz.
 - 2) $VBW \geq 1/T$.
 - 3) Detector = peak
 - 4) Sweep time = auto.
 - 5) Trace mode = max hold.
 - 6) Allow max hold to run for at least $[50 \times (1/D)]$ traces
- c. The EUT was placed on the top of a rotating table 0.8 meters (below 1GHz) / 1.5 meters (Above 1GHz) above the reference ground. The table was rotated 360 degrees to determine the position of the highest radiation.
- d. The EUT was set 3 meters away from the interference-receiving antenna (Below 1GHz) & (Above 1GHz), which was mounted on the top of a variable-height antenna tower.
- e. The height of antenna is varied from one meter to four meters above the ground to determine the maximum value of the field strength. Both horizontal and vertical polarizations of the antenna are set to make the measurement.
- f. For each suspected emission, the EUT was arranged to its worst case and then the antenna was tuned to heights from 1 meter to 4 meters and the rotatable table was turned from 0 degrees to 360 degrees to find the maximum reading.
- g. The test-receiver system was set to quasi-peak detect function and specified bandwidth with maximum hold mode when the test frequency is below 1 GHz.
- h. The test-receiver system was set to peak and average detected function and specified bandwidth with maximum hold mode when the test frequency is above 1 GHz. If the peak reading value also meets average limit, measurement with the average detector is unnecessary.

Note:

1. Test procedures for measuring FHSS device: The use of a duty cycle correction factor (DCCF) is permitted for calculating average radiated field strength emission levels for an FHSS device in 15.247. This DCCF can be applied when the unwanted emission limit is subject to an average field strength limit (e.g., within a Government Restricted band) and the conditions specified in Section 15.35(c) can be satisfied. The average radiated field strength is calculated by subtracting the DCCF from the maximum radiated field strength level as determined through measurement. The maximum radiated field strength level represents the worst-case (maximum amplitude) RMS measurement of the emission(s) during continuous transmission (i.e., not including any time intervals during which the transmitter is off or is transmitting at a reduced power level). It is also acceptable to apply the DCCF to a measurement performed with a peak detector instead of the specified RMS power averaging detector. Note that Section 15.35(c) specifies that the DCCF shall represent the worst-case (greatest duty cycle) over any 100 msec transmission period. Subclause 7.5 of ANSI C63.10 provides additional measurement guidance applicable to determination of the DCCF.
2. All modes of operation were investigated and the worst-case emissions are reported.

3.1.4 Deviation from Test Standard

No deviation.

Lab: [Hwa-Hsing \(Dongguan\) Testing Co., Ltd.](#)

Address: [No.101, Building N1, Yuyuan 2 Road, Yuyuan Industrial Park, HuangJiang Town, Dongguan City, People's Republic of China](#)

Tel: [0769-83078199](#)

Web.: [www.hwa-hsing.com](#)

E-Mail: [customerservice.dg@hwa-hsing.com](#)

Release

[Ver. 1.5](#)



3.1.5 Test Setup

Radiated emission below 30MHz:

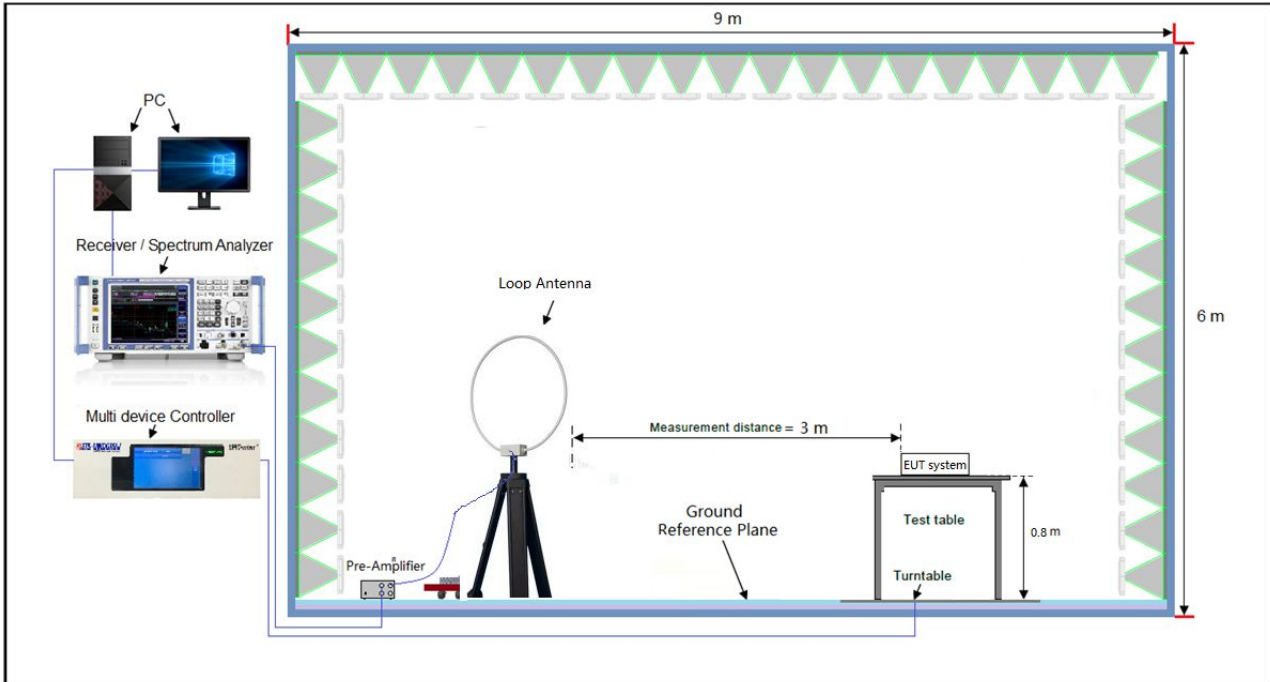

Frequency Range below 1GHz:

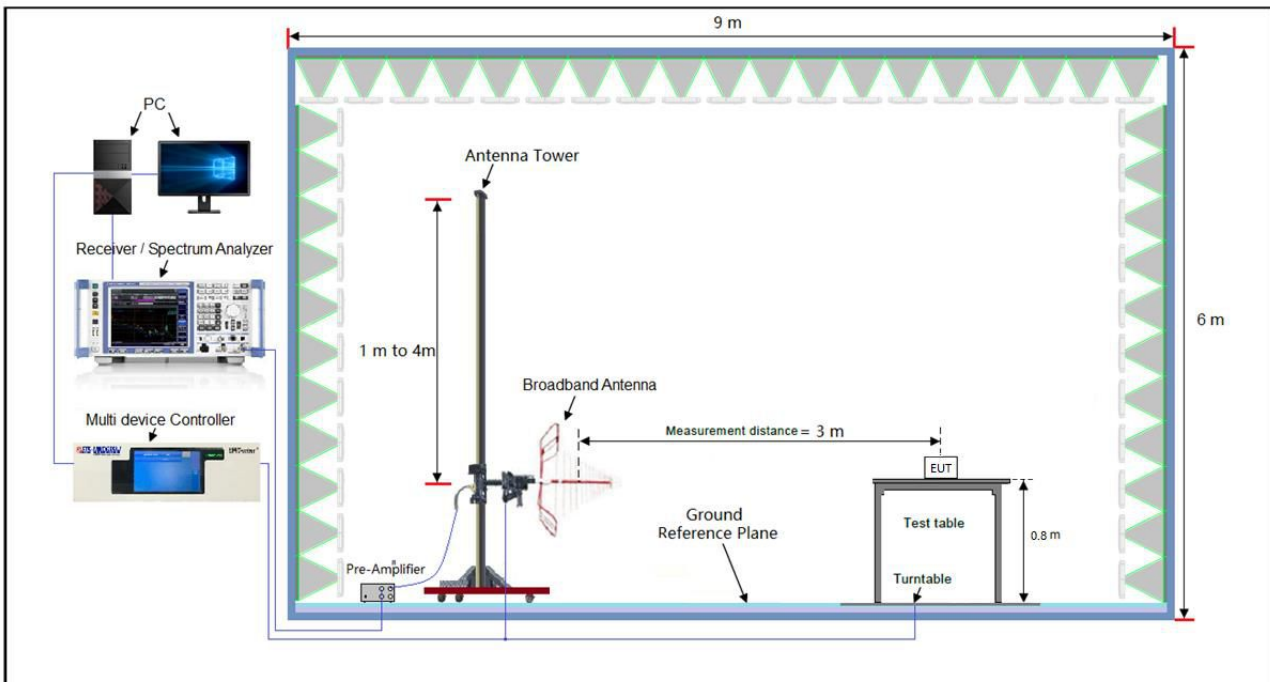



Frequency Range above 1GHz:

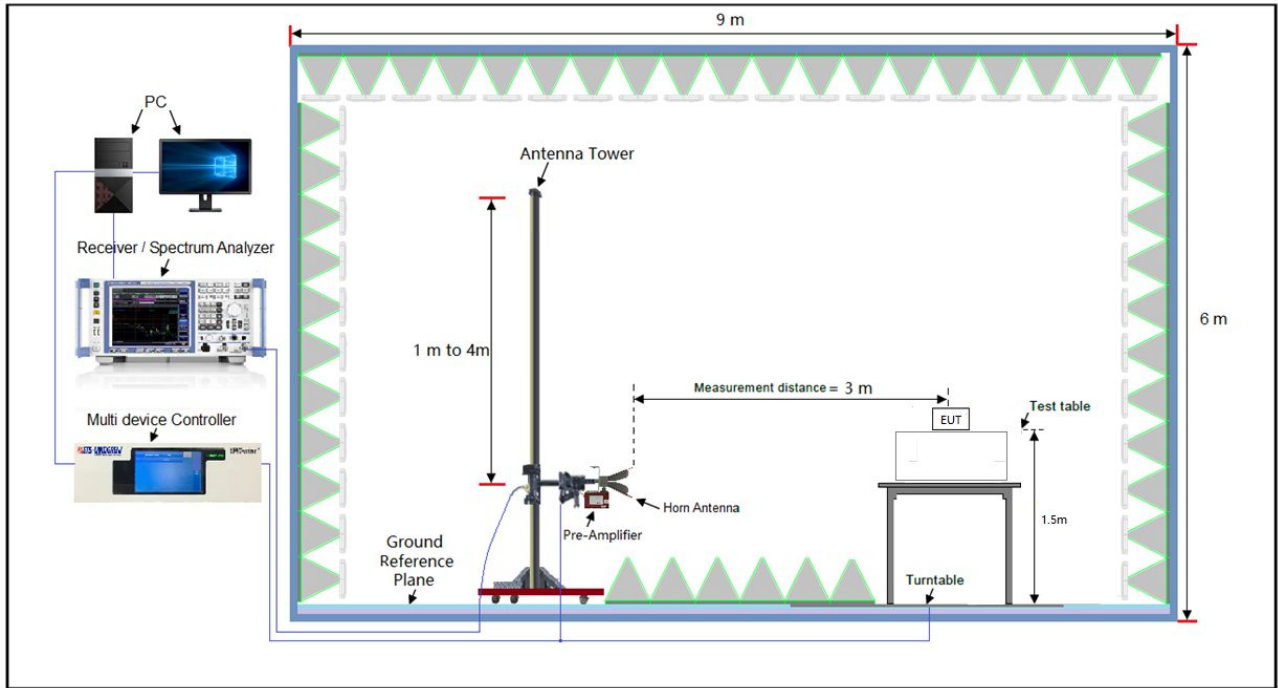

*For the actual test configuration, please refer to the attached file (Test Setup Photo).

3.1.6 EUT Operating Conditions

Set the EUT under transmission condition continuously at specific channel frequency.



3.1.7 Test Results

9 kHz ~ 30 MHz Data:

The amplitude of spurious emissions attenuated more than 20 dB below the permissible value is not required to be report.

30 MHz ~ 1GHz Worst-Case Data:

Frequency Range	30MHz ~ 1GHz	Detector Function	Peak (PK) Quasi-peak (QP)
Test Channel	Channel 0		

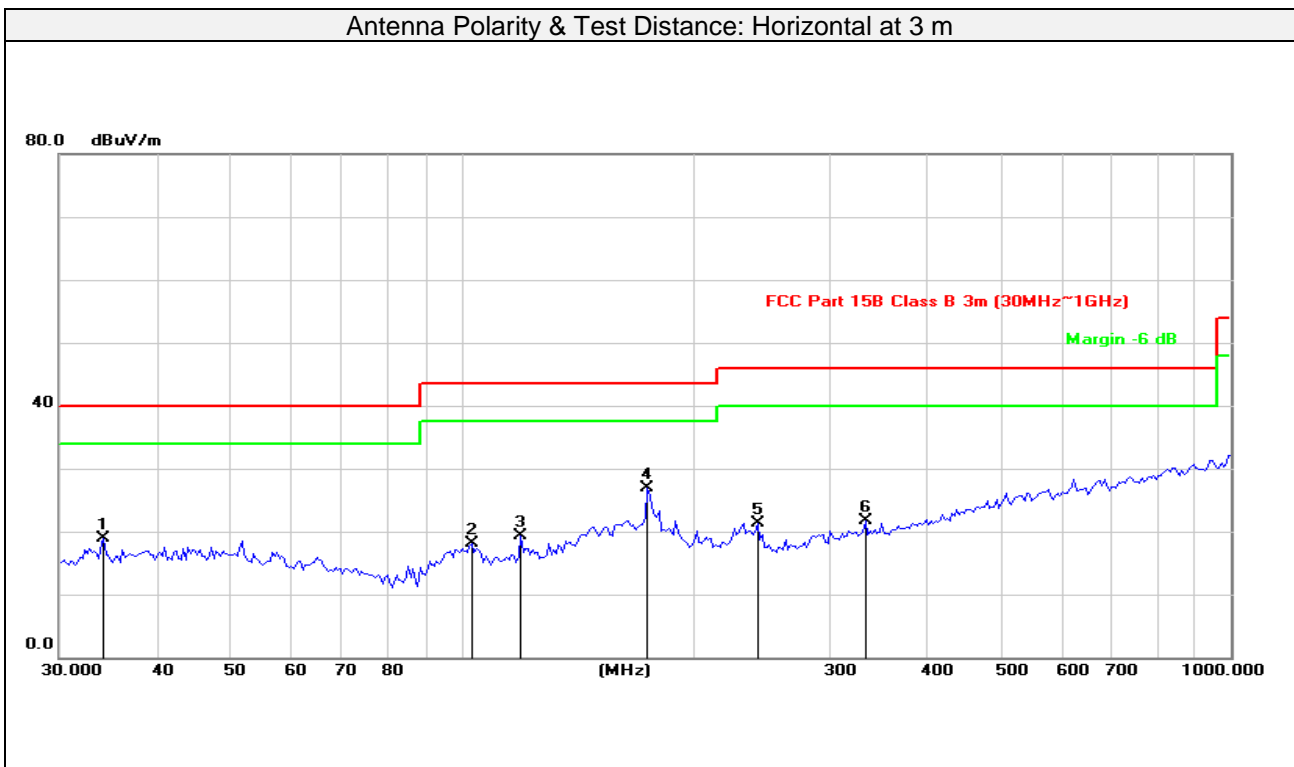

No.	Frequency (MHz)	Reading (dBuV)	Factor (dB)	Emission Level (dBuV/m)	Limit (dBuV/m)	Margin (dB)	Detector	Antenna Height (cm)	Table Angle (Degree)
1	34.2760	35.11	-16.13	18.98	40.00	-21.02	peak	144	230
2	103.0800	36.40	-18.30	18.10	43.50	-25.40	peak	122	201
3	119.4361	36.04	-16.78	19.26	43.50	-24.24	peak	163	158
4	174.4241	42.99	-16.03	26.96	43.50	-16.54	peak	215	214
5	242.5253	36.60	-15.30	21.30	46.00	-24.70	peak	263	55
6	334.8589	34.22	-12.47	21.75	46.00	-24.25	peak	255	263

Remarks:

- 1.Emission Level = Read Level + Factor (Antenna Factor + Cable Loss - Preamp Factor)
- 2.Margin value = Emission level – Limit value

Lab: [Hwa-Hsing \(Dongguan\) Testing Co., Ltd.](#)

Address: [No.101, Building N1, Yuyuan 2 Road, Yuyuan Industrial Park, HuangJiang Town, Dongguan City, People's Republic of China](#)

Tel: [0769-83078199](tel:0769-83078199)

Web.: www.hwa-hsing.com

E-Mail: customerservice.dg@hwa-hsing.com

Release Ver. 1.5



Frequency Range	30MHz ~ 1GHz	Detector Function	Peak (PK) Quasi-peak (QP)
Test Channel	Channel 0		

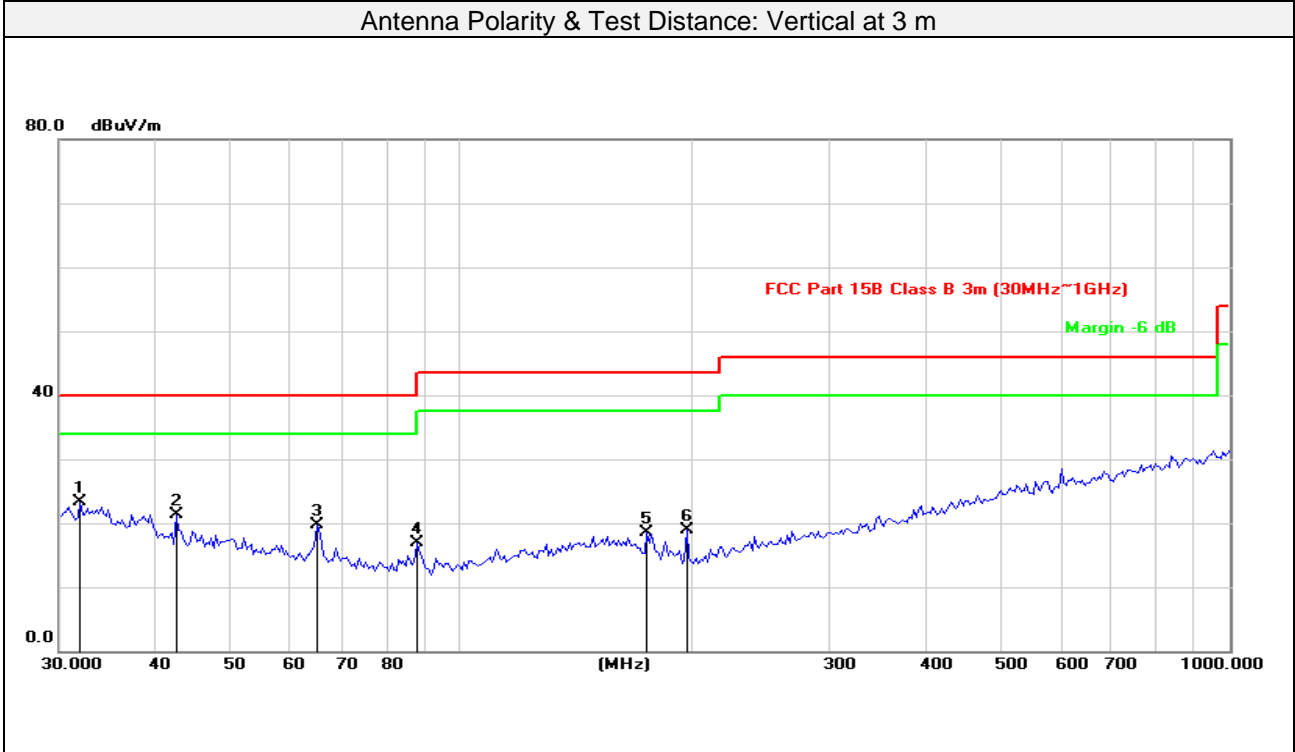

No.	Frequency (MHz)	Reading (dBUV)	Factor (dB)	Emission Level (dBUV/m)	Limit (dBUV/m)	Margin (dB)	Detector	Antenna Height (cm)	Table Angle (Degree)
1	31.9546	39.83	-16.59	23.24	40.00	-16.76	peak	185	89
2	42.6000	36.72	-15.37	21.35	40.00	-18.65	peak	163	263
3	64.8865	36.94	-17.30	19.64	40.00	-20.36	peak	215	125
4	87.7248	36.85	-19.97	16.88	40.00	-23.12	peak	266	230
5	174.4241	34.52	-16.03	18.49	43.50	-25.01	peak	214	210
6	196.5098	36.33	-17.48	18.85	43.50	-24.65	peak	152	236

Remarks:

1. Emission Level = Read Level + Factor (Antenna Factor + Cable Loss - Preamp Factor)
2. Margin value = Emission level – Limit value

Lab: [Hwa-Hsing \(Dongguan\) Testing Co., Ltd.](#)

Address: [No.101, Building N1, Yuyuan 2 Road, Yuyuan Industrial Park, HuangJiang Town, Dongguan City, People's Republic of China](#)

Tel: [0769-83078199](tel:0769-83078199)

Web.: www.hwa-hsing.com

E-Mail: customerservice.dg@hwa-hsing.com

Release

[Ver. 1.5](#)



Frequency Range	30MHz ~ 1GHz	Detector Function	Peak (PK) Quasi-peak (QP)
Test Channel	EDR 2402MHz+5160MHz		

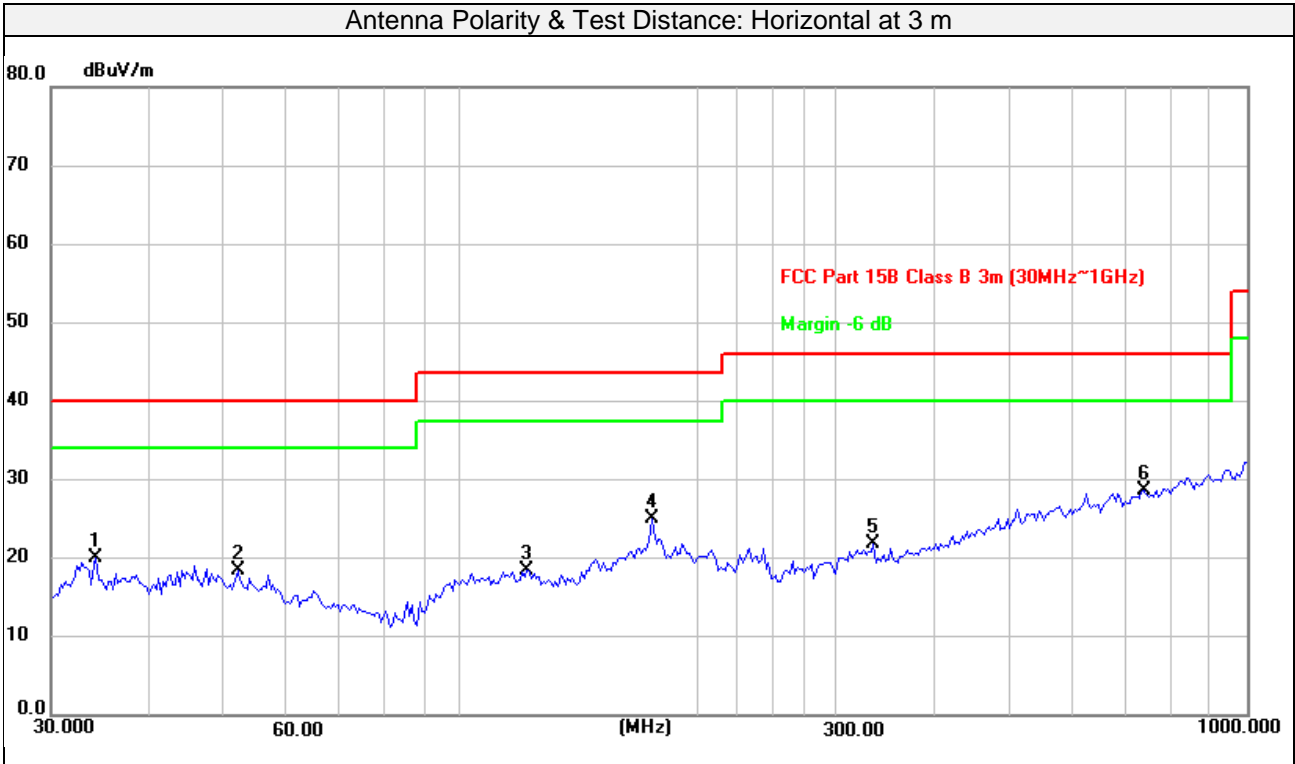

No.	Frequency (MHz)	Reading (dBuV)	Factor (dB)	Emission Level (dBuV/m)	Limit (dBuV/m)	Margin (dB)	Detector	Antenna Height (cm)	Table Angle (Degree)
1	34.2760	36.11	-16.13	19.98	40.00	-20.02	peak	199	24
2	51.8430	34.19	-15.75	18.44	40.00	-21.56	peak	207	335
3	121.1230	35.03	-16.66	18.37	43.50	-25.13	peak	186	263
4	174.4241	40.99	-16.03	24.96	43.50	-18.54	peak	226	117
5	334.8590	34.22	-12.47	21.75	46.00	-24.25	peak	235	185
6	739.6603	31.65	-2.97	28.68	46.00	-17.32	peak	186	166

Remarks:

1. Emission Level = Read Level + Factor (Antenna Factor + Cable Loss - Preamp Factor)
2. Margin value = Emission level – Limit value
3. This data is tested under Bluetooth and Other 5G emission state.

Lab: [Hwa-Hsing \(Dongguan\) Testing Co., Ltd.](#)

Address: [No.101, Building N1, Yuyuan 2 Road, Yuyuan Industrial Park, HuangJiang Town, Dongguan City, People's Republic of China](#)

Tel: [0769-83078199](tel:0769-83078199)

Web.: www.hwa-hsing.com

E-Mail: customerservice.dg@hwa-hsing.com

Release

[Ver. 1.5](#)



Frequency Range	30MHz ~ 1GHz	Detector Function	Peak (PK) Quasi-peak (QP)
Test Channel	EDR 2402MHz+5160MHz		

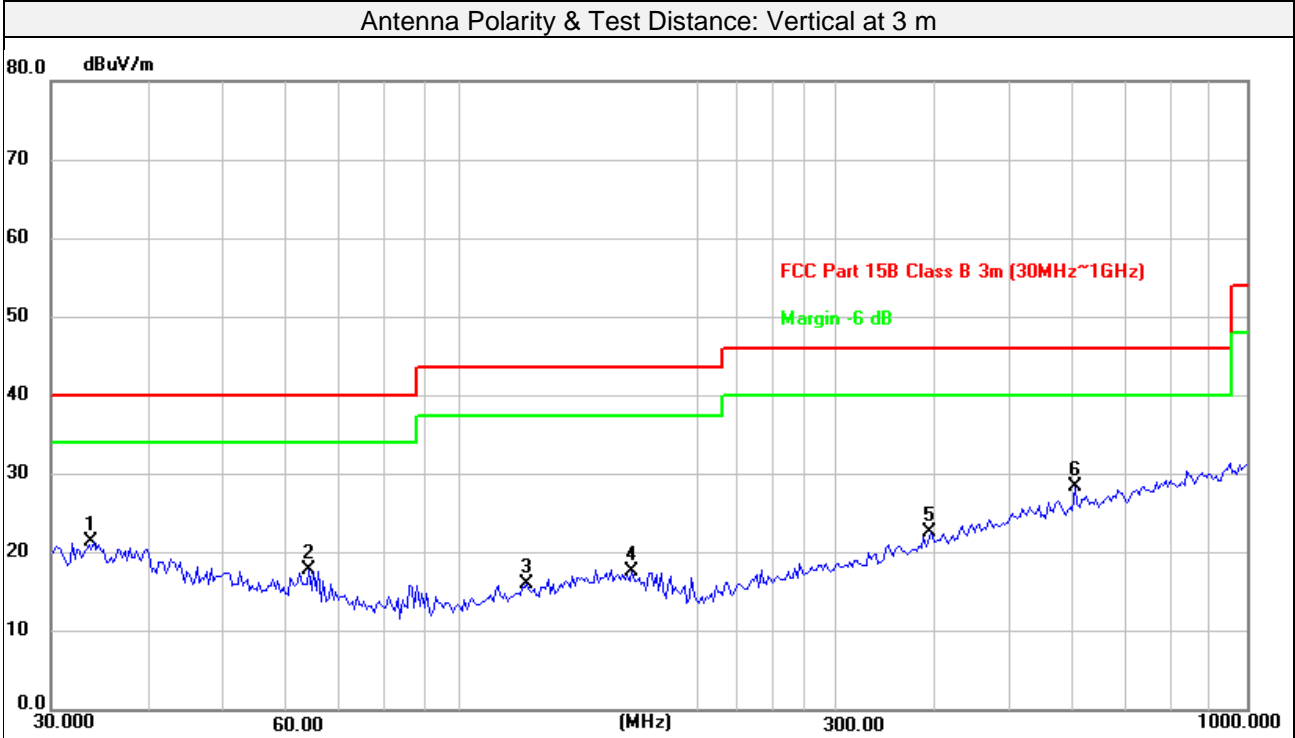

No.	Frequency (MHz)	Reading (dBuV)	Factor (dB)	Emission Level (dBuV/m)	Limit (dBuV/m)	Margin (dB)	Detector	Antenna Height (cm)	Table Angle (Degree)
1	34.0363	37.58	-16.17	21.41	40.00	-18.59	peak	124	108
2	63.9827	35.07	-17.18	17.89	40.00	-22.11	peak	115	226
3	121.1230	32.65	-16.66	15.99	43.50	-27.51	peak	150	345
4	164.9073	32.83	-15.16	17.67	43.50	-25.83	peak	106	263
5	396.2412	33.03	-10.40	22.63	46.00	-23.37	peak	100	15
6	603.5392	33.62	-5.16	28.46	46.00	-17.54	peak	137	86

Remarks:

1. Emission Level = Read Level + Factor (Antenna Factor + Cable Loss - Preamp Factor)
2. Margin value = Emission level – Limit value
3. This data is tested under Bluetooth and Other 5G emission state.

Lab: [Hwa-Hsing \(Dongguan\) Testing Co., Ltd.](#)

Address: [No.101, Building N1, Yuyuan 2 Road, Yuyuan Industrial Park, HuangJiang Town, Dongguan City, People's Republic of China](#)

Tel: [0769-83078199](tel:0769-83078199)

Web.: www.hwa-hsing.com

E-Mail: customerservice.dg@hwa-hsing.com

Release

[Ver. 1.5](#)



Above 1GHz Data:

GFSK

Frequency Range	1GHz ~ 25GHz	Detector Function	Peak (PK) Average (AVG)
Test Channel	Channel 0		

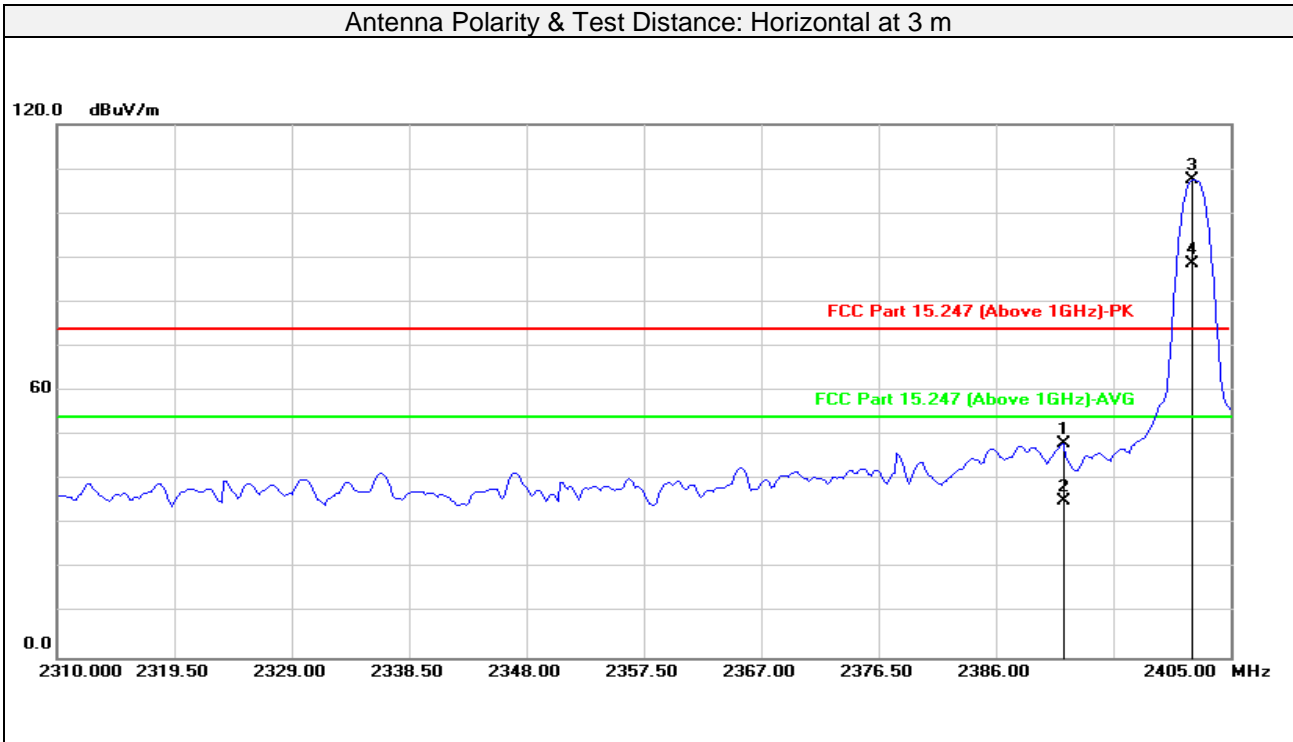

No.	Frequency (MHz)	Reading (dBuV)	Factor (dB)	Emission Level (dBuV/m)	Limit (dBuV/m)	Margin (dB)	Detector	Antenna Height (cm)	Table Angle (Degree)
1	2391.483	47.23	0.83	48.06	74.00	-25.94	peak	278	252
2	2391.483	34.47	0.83	35.30	54.00	-18.70	AVG	278	252
3#	2401.954	106.66	0.83	107.49			peak	278	252
4#	2401.954	87.77	0.83	88.60			AVG	278	252
5	4804.000	52.52	6.60	59.12	74.00	-14.88	peak	221	89
6	4804.000	43.55	6.60	50.15	54.00	-3.85	AVG	221	89
7	7206.000	39.73	10.08	49.81	74.00	-24.19	peak	124	236
8	7206.000	28.67	10.08	38.75	54.00	-15.25	AVG	124	236

Remarks:

- Emission Level = Read Level + Factor (Antenna Factor + Cable Loss - Preamp Factor)
Margin value = Emission level – Limit value
- #2402MHz: Fundamental frequency.
- The amplitude of spurious emissions attenuated more than 20 dB below the permissible value is not required to be report.



Frequency Range	1GHz ~ 25GHz	Detector Function	Peak (PK) Average (AVG)
Test Channel	Channel 0		

Antenna Polarity & Test Distance: Vertical at 3 m

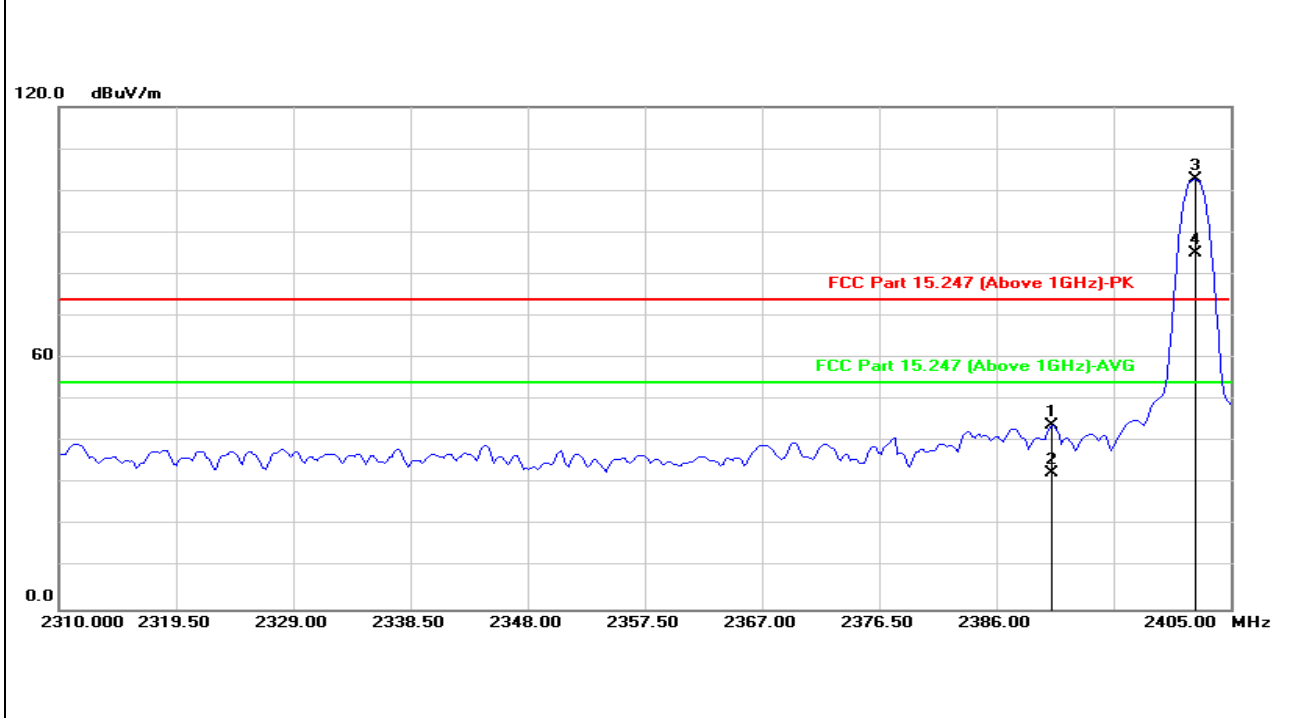

No.	Frequency (MHz)	Reading (dBuV)	Factor (dB)	Emission Level (dBuV/m)	Limit (dBuV/m)	Margin (dB)	Detector	Antenna Height (cm)	Table Angle (Degree)
1	2390.531	43.05	0.82	43.87	74.00	-30.13	peak	280	235
2	2390.531	31.66	0.82	32.48	54.00	-21.52	AVG	280	235
3#	2402.144	101.87	0.83	102.70			peak	280	235
4#	2402.144	84.36	0.83	85.19			AVG	280	235
5	4804.000	49.04	6.60	55.64	74.00	-18.36	peak	121	37
6	4804.000	39.54	6.60	46.14	54.00	-7.86	AVG	121	37
7	7206.000	41.00	10.08	51.08	74.00	-22.92	peak	104	326
8	7206.000	28.68	10.08	38.76	54.00	-15.24	AVG	104	326

Remarks:

- Emission Level = Read Level + Factor (Antenna Factor + Cable Loss - Preamp Factor)
Margin value = Emission level – Limit value
- #2402MHz: Fundamental frequency.
- The amplitude of spurious emissions attenuated more than 20 dB below the permissible value is not required to be report.



Frequency Range	1GHz ~ 25GHz	Detector Function	Peak (PK) Average (AVG)
Test Channel	Channel 39		

Antenna Polarity & Test Distance: Horizontal at 3 m									
No.	Frequency (MHz)	Reading (dBuV)	Factor (dB)	Emission Level (dBuV/m)	Limit (dBuV/m)	Margin (dB)	Detector	Antenna Height (cm)	Table Angle (Degree)
1 #	2441.000	101.34	0.83	102.17			peak	114	218
2 #	2441.000	82.74	0.83	83.57			AVG	114	218
3	4882.000	50.36	6.77	57.13	74.00	-16.87	peak	100	88
4	4882.000	42.09	6.77	48.86	54.00	-5.14	AVG	100	88
5	7323.000	39.62	10.37	49.99	74.00	-24.01	peak	154	227
6	7323.000	28.37	10.37	38.74	54.00	-15.26	AVG	154	227
Antenna Polarity & Test Distance: Vertical at 3 m									
No.	Frequency (MHz)	Reading (dBuV)	Factor (dB)	Emission Level (dBuV/m)	Limit (dBuV/m)	Margin (dB)	Detector	Antenna Height (cm)	Table Angle (Degree)
1 #	2441.000	102.71	0.83	103.54			peak	143	217
2 #	2441.000	84.53	0.83	85.36			AVG	143	217
3	4882.000	47.58	6.77	54.35	74.00	-19.65	peak	108	174
4	4882.000	38.58	6.77	45.35	54.00	-8.65	AVG	108	174
5	7323.000	41.21	10.37	51.58	74.00	-22.42	peak	107	336
6	7323.000	28.39	10.37	38.76	54.00	-15.24	AVG	107	336

Remarks:

- Emission Level = Read Level + Factor (Antenna Factor + Cable Loss - Preamp Factor)
Margin value = Emission level – Limit value
- #2441MHz: Fundamental frequency.
- The amplitude of spurious emissions attenuated more than 20 dB below the permissible value is not required to be report.



Frequency Range	1GHz ~ 25GHz	Detector Function	Peak (PK) Average (AVG)
Test Channel	Channel 78		

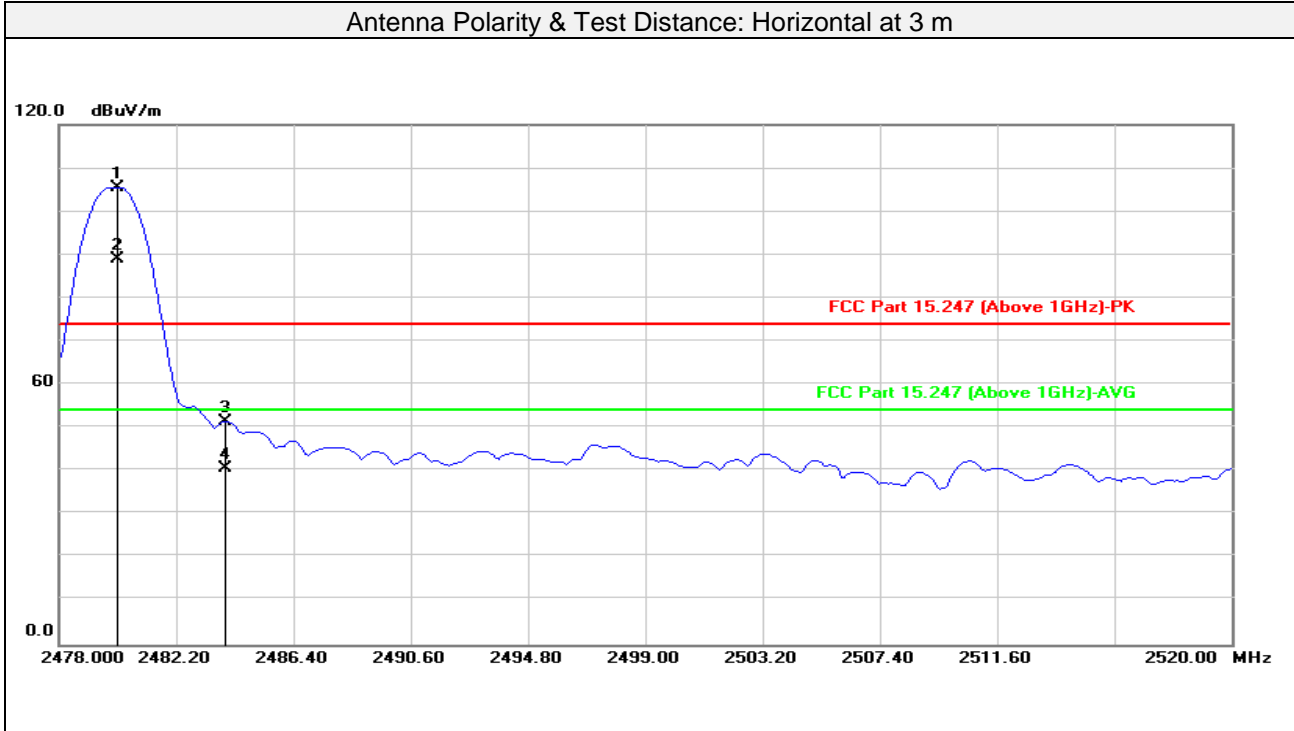

No.	Frequency (MHz)	Reading (dBuV)	Factor (dB)	Emission Level (dBuV/m)	Limit (dBuV/m)	Margin (dB)	Detector	Antenna Height (cm)	Table Angle (Degree)
1#	2480.104	104.71	0.85	105.56			peak	369	251
2#	2480.104	87.96	0.85	88.81			AVG	369	251
3	2483.976	50.61	0.86	51.47	74.00	-22.53	peak	369	251
4	2483.976	39.89	0.86	40.75	54.00	-13.25	AVG	369	251
5	4960.000	49.99	6.93	56.92	74.00	-17.08	peak	100	91
6	4960.000	41.07	6.93	48.00	54.00	-6.00	AVG	100	91
7	7440.000	39.31	10.67	49.98	74.00	-24.02	peak	220	352
8	7440.000	28.21	10.67	38.88	54.00	-15.12	AVG	220	352

Remarks:

- Emission Level = Read Level + Factor (Antenna Factor + Cable Loss - Preamp Factor)
Margin value = Emission level – Limit value
- #2480MHz: Fundamental frequency.
- The amplitude of spurious emissions attenuated more than 20 dB below the permissible value is not required to be report.



Frequency Range	1GHz ~ 25GHz	Detector Function	Peak (PK) Average (AVG)
Test Channel	Channel 78		

Antenna Polarity & Test Distance: Vertical at 3 m

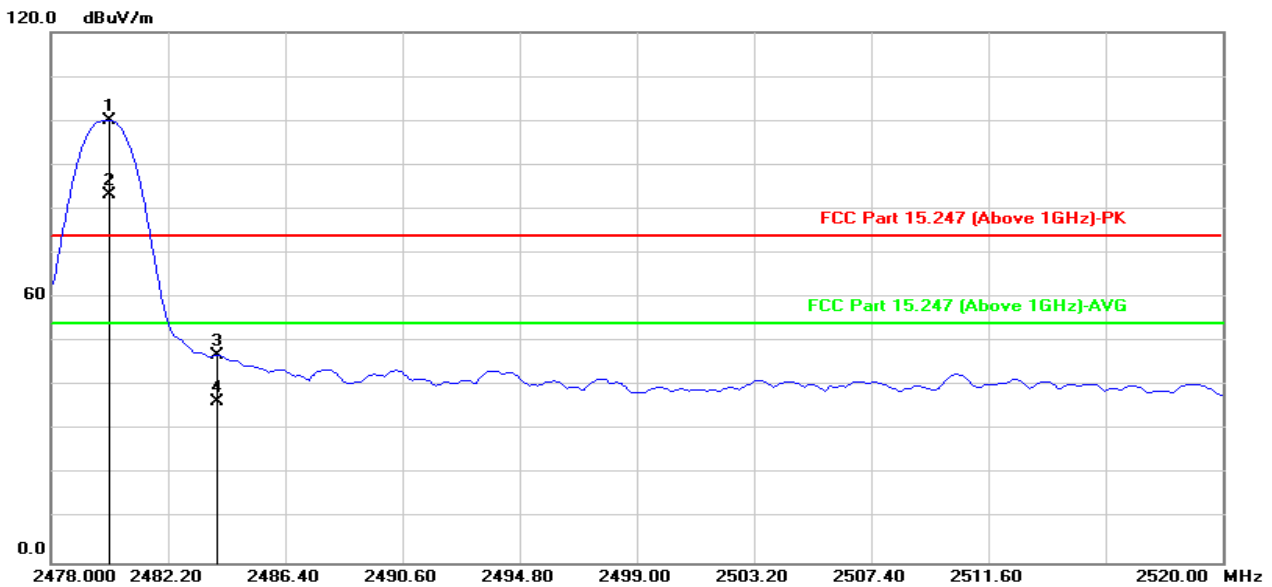

No.	Frequency (MHz)	Reading (dBuV)	Factor (dB)	Emission Level (dBuV/m)	Limit (dBuV/m)	Margin (dB)	Detector	Antenna Height (cm)	Table Angle (Degree)
1#	2480.104	99.09	0.85	99.94			peak	122	152
2#	2480.104	82.40	0.85	83.25			AVG	122	152
3	2483.976	46.09	0.86	46.95	74.00	-27.05	peak	122	152
4	2483.976	35.63	0.86	36.49	54.00	-17.51	AVG	122	152
5	4960.000	47.78	6.93	54.71	74.00	-19.29	peak	100	242
6	4960.000	38.37	6.93	45.30	54.00	-8.70	AVG	100	242
7	7440.000	41.88	10.67	52.55	74.00	-21.45	peak	134	76
8	7440.000	28.15	10.67	38.82	54.00	-15.18	AVG	134	76

Remarks:

- Emission Level = Read Level + Factor (Antenna Factor + Cable Loss - Preamp Factor)
Margin value = Emission level – Limit value
- #2480MHz: Fundamental frequency.
- The amplitude of spurious emissions attenuated more than 20 dB below the permissible value is not required to be report.

Lab: [Hwa-Hsing \(Dongguan\) Testing Co., Ltd.](#)

Address: [No.101, Building N1, Yuyuan 2 Road, Yuyuan Industrial Park, HuangJiang Town, Dongguan City, People's Republic of China](#)

Tel: [0769-83078199](tel:0769-83078199)

Web.: www.hwa-hsing.com

E-Mail: customerservice.dg@hwa-hsing.com

Release
Ver. 1.5



8DPSK

Frequency Range	1GHz ~ 25GHz	Detector Function	Peak (PK) Average (AVG)
Test Channel	Channel 0		

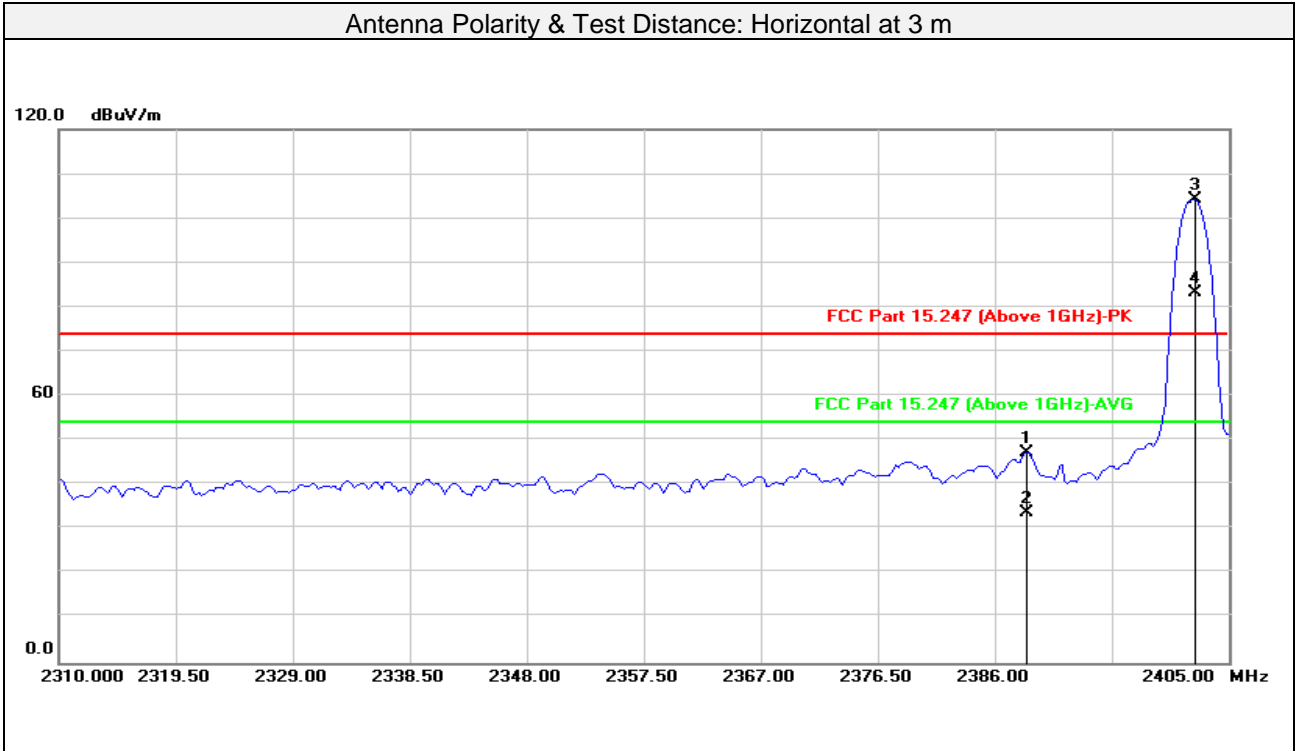

No.	Frequency (MHz)	Reading (dBuV)	Factor (dB)	Emission Level (dBuV/m)	Limit (dBuV/m)	Margin (dB)	Detector	Antenna Height (cm)	Table Angle (Degree)
1	2388.627	46.43	0.83	47.26	74.00	-26.74	peak	100	62
2	2388.627	32.80	0.83	33.63	54.00	-20.37	AVG	100	62
3#	2402.335	103.36	0.83	104.19			peak	100	62
4#	2402.335	82.48	0.83	83.31			AVG	100	62
5	4804.000	55.29	6.60	61.89	74.00	-12.11	peak	101	89
6	4804.000	42.18	6.60	48.78	54.00	-5.22	AVG	101	89
7	7206.000	39.33	10.08	49.41	74.00	-24.59	peak	122	261
8	7206.000	28.54	10.08	38.62	54.00	-15.38	AVG	122	261

Remarks:

- Emission Level = Read Level + Factor (Antenna Factor + Cable Loss - Preamp Factor)
Margin value = Emission level – Limit value
- #2402MHz: Fundamental frequency.
- The amplitude of spurious emissions attenuated more than 20 dB below the permissible value is not required to be report.

Lab: [Hwa-Hsing \(Dongguan\) Testing Co., Ltd.](#)

Address: [No.101, Building N1, Yuyuan 2 Road, Yuyuan Industrial Park, HuangJiang Town, Dongguan City, People's Republic of China](#)

Tel: [0769-83078199](tel:0769-83078199)

Web.: www.hwa-hsing.com

E-Mail: customerservice.dg@hwa-hsing.com

Release

[Ver. 1.5](#)



Frequency Range	1GHz ~ 25GHz	Detector Function	Peak (PK) Average (AVG)
Test Channel	Channel 0		

Antenna Polarity & Test Distance: Vertical at 3 m

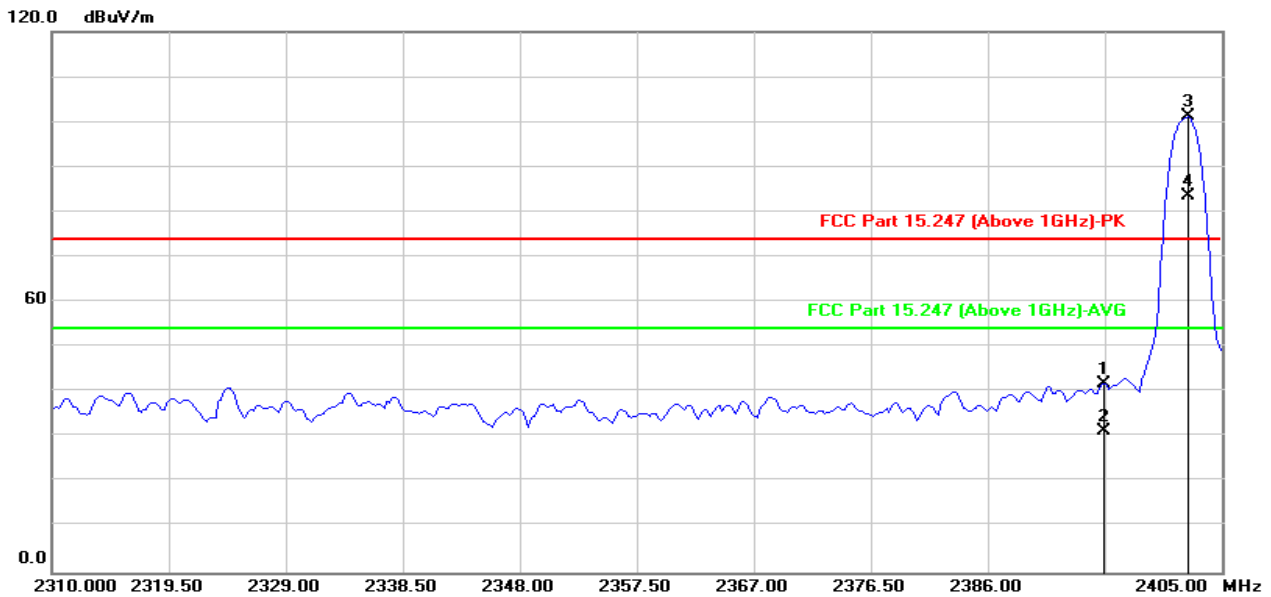

No.	Frequency (MHz)	Reading (dBuV)	Factor (dB)	Emission Level (dBuV/m)	Limit (dBuV/m)	Margin (dB)	Detector	Antenna Height (cm)	Table Angle (Degree)
1	2395.481	41.03	0.83	41.86	74.00	-32.14	peak	277	238
2	2395.481	30.53	0.83	31.36	54.00	-22.64	AVG	277	238
3#	2402.335	100.34	0.83	101.17			peak	277	238
4#	2402.335	82.57	0.83	83.40			AVG	277	238
5	4804.000	51.89	6.60	58.49	74.00	-15.51	peak	112	8
6	4804.000	39.71	6.60	46.31	54.00	-7.69	AVG	112	8
7	7206.000	40.23	10.08	50.31	74.00	-23.69	peak	154	315
8	7206.000	28.51	10.08	38.59	54.00	-15.41	AVG	154	315

Remarks:

- Emission Level = Read Level + Factor (Antenna Factor + Cable Loss - Preamp Factor)
Margin value = Emission level – Limit value
- #2402MHz: Fundamental frequency.
- The amplitude of spurious emissions attenuated more than 20 dB below the permissible value is not required to be report.

Lab: [Hwa-Hsing \(Dongguan\) Testing Co., Ltd.](#)

Address: [No.101, Building N1, Yuyuan 2 Road, Yuyuan Industrial Park, HuangJiang Town, Dongguan City, People's Republic of China](#)

Tel: [0769-83078199](tel:0769-83078199)

Web.: www.hwa-hsing.com

E-Mail: customerservice.dg@hwa-hsing.com

Release

[Ver. 1.5](#)



Frequency Range	1GHz ~ 25GHz	Detector Function	Peak (PK) Average (AVG)
Test Channel	Channel 39		

Antenna Polarity & Test Distance: Horizontal at 3 m									
No.	Frequency (MHz)	Reading (dBuV)	Factor (dB)	Emission Level (dBuV/m)	Limit (dBuV/m)	Margin (dB)	Detector	Antenna Height (cm)	Table Angle (Degree)
1#	2441.000	103.40	0.83	104.23			peak	215	94
2#	2441.000	81.14	0.83	81.97			AVG	215	94
3	4882.000	51.12	6.77	57.89	74.00	-16.11	peak	100	89
4	4882.000	39.23	6.77	46.00	54.00	-8.00	AVG	100	89
5	7323.000	42.34	10.37	52.71	74.00	-21.29	peak	221	169
6	7323.000	28.36	10.37	38.73	54.00	-15.27	AVG	221	169
Antenna Polarity & Test Distance: Vertical at 3 m									
No.	Frequency (MHz)	Reading (dBuV)	Factor (dB)	Emission Level (dBuV/m)	Limit (dBuV/m)	Margin (dB)	Detector	Antenna Height (cm)	Table Angle (Degree)
1#	2441.000	102.13	0.83	102.96			peak	127	236
2#	2441.000	83.79	0.83	84.62			AVG	127	236
3	4882.000	47.87	6.77	54.64	74.00	-19.36	peak	117	6
4	4882.000	35.85	6.77	42.62	54.00	-11.38	AVG	117	6
5	7323.000	40.41	10.37	50.78	74.00	-23.22	peak	100	235
6	7323.000	28.40	10.37	38.77	54.00	-15.23	AVG	100	235

Remarks:

- Emission Level = Read Level + Factor (Antenna Factor + Cable Loss - Preamp Factor)
Margin value = Emission level – Limit value
- #2441MHz: Fundamental frequency.
- The amplitude of spurious emissions attenuated more than 20 dB below the permissible value is not required to be report.



Frequency Range	1GHz ~ 25GHz	Detector Function	Peak (PK) Average (AVG)
Test Channel	Channel 78		

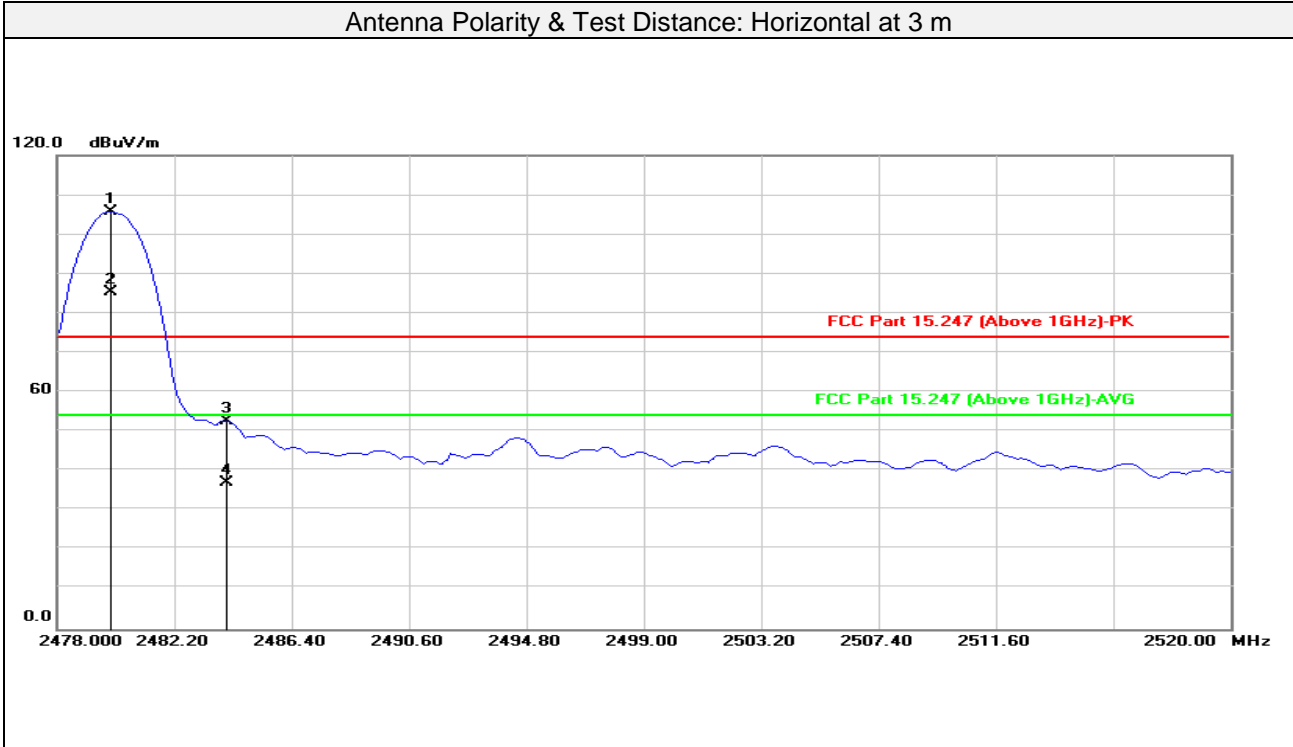

No.	Frequency (MHz)	Reading (dBuV)	Factor (dB)	Emission Level (dBuV/m)	Limit (dBuV/m)	Margin (dB)	Detector	Antenna Height (cm)	Table Angle (Degree)
1#	2479.936	104.86	0.85	105.71			peak	366	251
2#	2479.936	84.59	0.85	85.44			AVG	366	251
3	2484.060	51.86	0.86	52.72	74.00	-21.28	peak	366	251
4	2484.060	36.29	0.86	37.15	54.00	-16.85	AVG	366	251
5	4960.000	51.14	6.93	58.07	74.00	-15.93	peak	100	93
6	4960.000	38.64	6.93	45.57	54.00	-8.43	AVG	100	93
7	7440.000	39.78	10.67	50.45	74.00	-23.55	peak	128	304
8	7440.000	28.22	10.67	38.89	54.00	-15.11	AVG	128	304

Remarks:

- Emission Level = Read Level + Factor (Antenna Factor + Cable Loss - Preamp Factor)
Margin value = Emission level – Limit value
- #2480MHz: Fundamental frequency.
- The amplitude of spurious emissions attenuated more than 20 dB below the permissible value is not required to be report.

Lab: [Hwa-Hsing \(Dongguan\) Testing Co., Ltd.](#)

Address: [No.101, Building N1, Yuyuan 2 Road, Yuyuan Industrial Park, HuangJiang Town, Dongguan City, People's Republic of China](#)

Tel: [0769-83078199](tel:0769-83078199)

Web.: www.hwa-hsing.com

E-Mail: customerservice.dg@hwa-hsing.com

Release

[Ver. 1.5](#)



Frequency Range	1GHz ~ 25GHz	Detector Function	Peak (PK) Average (AVG)
Test Channel	Channel 78		

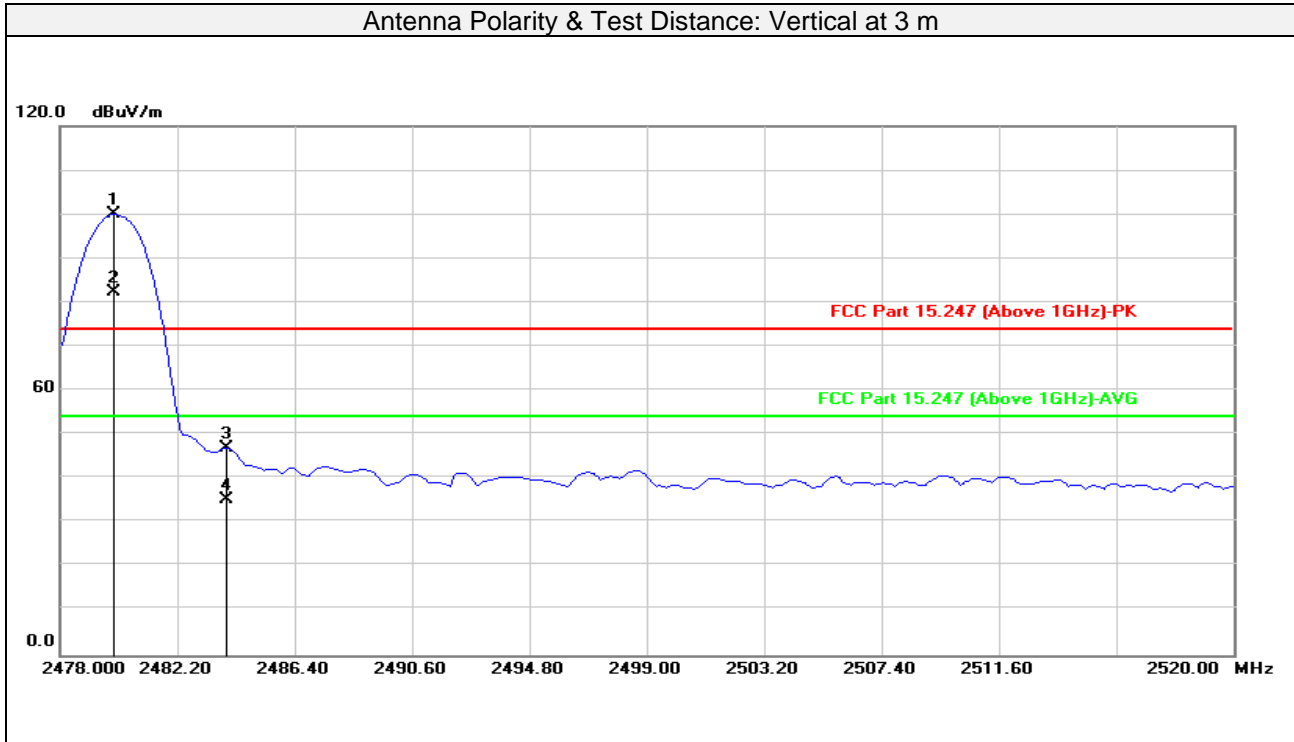

No.	Frequency (MHz)	Reading (dBuV)	Factor (dB)	Emission Level (dBuV/m)	Limit (dBuV/m)	Margin (dB)	Detector	Antenna Height (cm)	Table Angle (Degree)
1#	2479.936	99.22	0.85	100.07			peak	126	151
2#	2479.936	81.39	0.85	82.24			AVG	126	151
3	2483.976	46.02	0.86	46.88	74.00	-27.12	peak	126	151
4	2483.976	34.40	0.86	35.26	54.00	-18.74	AVG	126	151
5	4960.000	46.50	6.93	53.43	74.00	-20.57	peak	121	241
6	4960.000	34.88	6.93	41.81	54.00	-12.19	AVG	121	241
7	7440.000	40.90	10.67	51.57	74.00	-22.43	peak	103	197
8	7440.000	28.17	10.67	38.84	54.00	-15.16	AVG	103	197

Remarks:

- Emission Level = Read Level + Factor (Antenna Factor + Cable Loss - Preamp Factor)
Margin value = Emission level – Limit value
- #2480MHz: Fundamental frequency.
- The amplitude of spurious emissions attenuated more than 20 dB below the permissible value is not required to be report.



Above 1GHz Data:

GFSK+SRD

Frequency Range	1GHz ~ 25GHz	Detector Function	Peak (PK) Average (AVG)
Test Channel	2402MHz+5160MHz		

Antenna Polarity & Test Distance: Horizontal at 3 m									
No.	Frequency (MHz)	Reading (dBuV)	Factor (dB)	Emission Level (dBuV/m)	Limit (dBuV/m)	Margin (dB)	Detector	Antenna Height (cm)	Table Angle (Degree)
1#	2402.000	106.39	-0.39	106.00			peak	156	16
2#	2402.000	87.51	-0.39	87.12			AVG	156	16
3	4804.000	53.49	5.30	58.79	74.00	-15.21	peak	177	104
4	4804.000	44.96	5.30	50.26	54.00	-3.74	AVG	177	104
5#	5160.000	97.30	8.18	105.48			peak	210	247
6#	5160.000	78.06	8.18	86.24			AVG	210	247
7	7206.000	35.87	12.40	48.27	74.00	-25.73	peak	226	258
8	7206.000	26.06	12.40	38.46	54.00	-15.54	AVG	226	258
9	10320.000	34.87	17.77	52.64	74.00	-21.36	peak	269	248
10	10320.000	26.24	17.77	44.01	54.00	-9.99	AVG	269	248
11	15480.000	23.98	22.30	46.28	74.00	-27.72	peak	284	315
12	15480.000	16.13	22.30	38.43	54.00	-15.57	AVG	284	315

Antenna Polarity & Test Distance: Vertical at 3 m									
No.	Frequency (MHz)	Reading (dBuV)	Factor (dB)	Emission Level (dBuV/m)	Limit (dBuV/m)	Margin (dB)	Detector	Antenna Height (cm)	Table Angle (Degree)
1#	2402.000	105.87	-0.39	105.48			peak	105	269
2#	2402.000	86.86	-0.39	86.47			AVG	105	269
3	4804.000	50.94	5.30	56.24	74.00	-17.76	peak	112	265
4	4804.000	41.57	5.30	46.87	54.00	-7.13	AVG	112	265
5#	5160.000	98.12	8.18	106.30			peak	134	337
6#	5160.000	80.58	8.18	88.76			AVG	134	337
7	7206.000	39.45	12.40	51.85	74.00	-22.15	peak	147	197
8	7206.000	26.93	12.40	39.33	54.00	-14.67	AVG	147	197
9	10320.000	38.97	17.77	56.74	74.00	-17.26	peak	105	218
10	10320.000	28.04	17.77	45.81	54.00	-8.19	AVG	105	218
11	15480.000	23.98	22.30	46.28	74.00	-27.72	peak	137	84
12	15480.000	17.86	22.30	40.16	54.00	-13.84	AVG	137	84

Remarks:

1. Emission Level = Read Level + Factor (Antenna Factor + Cable Loss - Preamp Factor)
Margin value = Emission level – Limit value
2. The amplitude of spurious emissions attenuated more than 20 dB below the permissible value is not required to be report.
3. This data is tested under Bluetooth and Other 5G emission state.

Lab: [Hwa-Hsing \(Dongguan\) Testing Co., Ltd.](#)

Address: [No.101, Building N1, Yuyuan 2 Road, Yuyuan Industrial Park, HuangJiang Town, Dongguan City, People's Republic of China](#)

Tel: [0769-83078199](tel:0769-83078199)

Web.: www.hwa-hsing.com

E-Mail: customerservice.dg@hwa-hsing.com

Release

[Ver. 1.5](#)



Frequency Range	1GHz ~ 25GHz	Detector Function	Peak (PK) Average (AVG)
Test Channel	2441MHz+5160MHz		

Antenna Polarity & Test Distance: Horizontal at 3 m

No.	Frequency (MHz)	Reading (dBUV)	Factor (dB)	Emission Level (dBUV/m)	Limit (dBUV/m)	Margin (dB)	Detector	Antenna Height (cm)	Table Angle (Degree)
1#	2441.000	106.53	-0.30	106.23			peak	221	12
2#	2441.000	86.72	-0.30	86.42			AVG	221	12
3	4882.000	53.15	6.27	59.42	74.00	-14.58	peak	157	93
4	4882.000	43.06	6.27	49.33	54.00	-4.67	AVG	157	93
5#	5160.000	99.16	8.18	107.34			peak	238	285
6#	5160.000	80.03	8.18	88.21			AVG	238	285
7	7323.000	33.63	12.65	46.28	74.00	-27.72	peak	166	332
8	7323.000	24.61	12.65	37.26	54.00	-16.74	AVG	166	332
9	10320.000	38.17	17.77	55.94	74.00	-18.06	peak	182	214
10	10320.000	28.31	17.77	46.08	54.00	-7.92	AVG	182	214
11	15480.000	23.43	22.30	45.73	74.00	-28.27	peak	175	148
12	15480.000	18.92	22.30	41.22	54.00	-12.78	AVG	175	148

Antenna Polarity & Test Distance: Vertical at 3 m

No.	Frequency (MHz)	Reading (dBUV)	Factor (dB)	Emission Level (dBUV/m)	Limit (dBUV/m)	Margin (dB)	Detector	Antenna Height (cm)	Table Angle (Degree)
1#	2441.000	106.53	-0.30	106.23			peak	126	117
2#	2441.000	85.56	-0.30	85.26			AVG	126	117
3	4882.000	47.91	6.27	54.18	74.00	-19.82	peak	134	54
4	4882.000	38.96	6.27	45.23	54.00	-8.77	AVG	134	54
5#	5160.000	96.15	8.18	104.33			peak	105	11
6#	5160.000	77.06	8.18	85.24			AVG	105	11
7	7323.000	33.08	12.65	45.73	74.00	-28.27	peak	150	133
8	7323.000	23.86	12.65	36.51	54.00	-17.49	AVG	150	133
9	10320.000	37.72	17.77	55.49	74.00	-18.51	peak	149	103
10	10320.000	27.43	17.77	45.20	54.00	-8.80	AVG	149	103
11	15480.000	22.02	22.30	44.32	74.00	-29.68	peak	120	31
12	15480.000	15.89	22.30	38.19	54.00	-15.81	AVG	120	31

Remarks:

1. Emission Level = Read Level + Factor (Antenna Factor + Cable Loss - Preamp Factor)
Margin value = Emission level – Limit value
2. The amplitude of spurious emissions attenuated more than 20 dB below the permissible value is not required to be report.
3. This data is tested under Bluetooth and Other 5G emission state.

Lab: [Hwa-Hsing \(Dongguan\) Testing Co., Ltd.](#)
 Address: [No.101, Building N1, Yuyuan 2 Road, Yuyuan Industrial Park, HuangJiang Town, Dongguan City, People's Republic of China](#)

Tel: [0769-83078199](tel:0769-83078199)
 Web.: www.hwa-hsing.com
 E-Mail: customerservice.dg@hwa-hsing.com

Release
Ver. 1.5



Frequency Range	1GHz ~ 25GHz	Detector Function	Peak (PK) Average (AVG)
Test Channel	2480MHz+5160MHz		

Antenna Polarity & Test Distance: Horizontal at 3 m									
No.	Frequency (MHz)	Reading (dBuV)	Factor (dB)	Emission Level (dBuV/m)	Limit (dBuV/m)	Margin (dB)	Detector	Antenna Height (cm)	Table Angle (Degree)
1#	2480.000	103.46	-0.21	103.25			peak	136	31
2#	2480.000	88.42	-0.21	88.21			AVG	136	31
3	4960.000	46.98	6.16	53.14	74.00	-20.86	peak	142	117
4	4960.000	40.16	6.16	46.32	54.00	-7.68	AVG	142	117
5#	5160.000	96.13	8.18	104.31			peak	150	68
6#	5160.000	76.94	8.18	85.12			AVG	150	68
7	7440.000	31.82	12.91	44.73	74.00	-29.27	peak	138	109
8	7440.000	22.51	12.91	35.42	54.00	-18.58	AVG	138	109
9	10320.000	36.84	17.77	54.61	74.00	-19.39	peak	129	242
10	10320.000	27.12	17.77	44.89	54.00	-9.11	AVG	129	242
11	15480.000	23.32	22.30	45.62	74.00	-28.38	peak	107	307
12	15480.000	16.28	22.30	38.58	54.00	-15.42	AVG	107	307

Antenna Polarity & Test Distance: Vertical at 3 m									
No.	Frequency (MHz)	Reading (dBuV)	Factor (dB)	Emission Level (dBuV/m)	Limit (dBuV/m)	Margin (dB)	Detector	Antenna Height (cm)	Table Angle (Degree)
1#	2480.000	102.21	-0.21	102.00			peak	228	59
2#	2480.000	83.47	-0.21	83.26			AVG	228	59
3	4960.000	54.08	6.16	60.24	74.00	-13.76	peak	200	263
4	4960.000	44.50	6.16	50.66	54.00	-3.34	AVG	200	263
5#	5160.000	95.47	8.18	103.65			peak	165	337
6#	5160.000	75.08	8.18	83.26			AVG	165	337
7	7440.000	32.10	12.91	45.01	74.00	-28.99	peak	178	53
8	7440.000	21.75	12.91	34.66	54.00	-19.34	AVG	178	53
9	10320.000	36.60	17.77	54.37	74.00	-19.63	peak	236	167
10	10320.000	27.25	17.77	45.02	54.00	-8.98	AVG	236	167
11	15480.000	23.07	22.30	45.37	74.00	-28.63	peak	254	212
12	15480.000	20.36	22.30	42.66	54.00	-11.34	AVG	254	212

Remarks:

1. Emission Level = Read Level + Factor (Antenna Factor + Cable Loss - Preamp Factor)
Margin value = Emission level – Limit value
2. The amplitude of spurious emissions attenuated more than 20 dB below the permissible value is not required to be report.
3. This data is tested under Bluetooth and Other 5G emission state.

Lab: [Hwa-Hsing \(Dongguan\) Testing Co., Ltd.](#)
 Address: [No.101, Building N1, Yuyuan 2 Road, Yuyuan Industrial Park, Huangjiang Town, Dongguan City, People's Republic of China](#)

Tel: [0769-83078199](tel:0769-83078199)
 Web.: www.hwa-hsing.com
 E-Mail: customerservice.dg@hwa-hsing.com

Release
Ver. 1.5



8DPSK+SRD

Frequency Range	1GHz ~ 25GHz	Detector Function	Peak (PK) Average (AVG)
Test Channel	2402MHz+5160MHz		

Antenna Polarity & Test Distance: Horizontal at 3 m									
No.	Frequency (MHz)	Reading (dBUV)	Factor (dB)	Emission Level (dBUV/m)	Limit (dBUV/m)	Margin (dB)	Detector	Antenna Height (cm)	Table Angle (Degree)
1#	2402.000	104.61	-0.39	104.22			peak	116	26
2#	2402.000	87.63	-0.39	87.24			AVG	116	26
3	4804.000	50.04	5.30	55.34	74.00	-18.66	peak	100	226
4	4804.000	40.08	5.30	45.38	54.00	-8.62	AVG	100	226
5#	5160.000	99.47	8.18	107.65			peak	150	242
6#	5160.000	77.03	8.18	85.21			AVG	150	242
7	7206.000	40.03	12.40	52.43	74.00	-21.57	peak	134	77
8	7206.000	27.72	12.40	40.12	54.00	-13.88	AVG	134	77
9	10320.000	38.07	17.77	55.84	74.00	-18.16	peak	109	143
10	10320.000	28.45	17.77	46.22	54.00	-7.78	AVG	109	143
11	15480.000	23.05	22.30	45.35	74.00	-28.65	peak	127	122
12	15480.000	17.27	22.30	39.57	54.00	-14.43	AVG	127	122

Antenna Polarity & Test Distance: Vertical at 3 m									
No.	Frequency (MHz)	Reading (dBUV)	Factor (dB)	Emission Level (dBUV/m)	Limit (dBUV/m)	Margin (dB)	Detector	Antenna Height (cm)	Table Angle (Degree)
1#	2402.000	106.63	-0.39	106.24			peak	221	105
2#	2402.000	87.14	-0.39	86.75			AVG	221	105
3	4804.000	52.64	5.30	57.94	74.00	-16.06	peak	150	243
4	4804.000	44.83	5.30	50.13	54.00	-3.87	AVG	150	243
5#	5160.000	96.31	8.18	104.49			peak	236	206
6#	5160.000	80.28	8.18	88.46			AVG	236	206
7	7206.000	35.45	12.40	47.85	74.00	-26.15	peak	189	188
8	7206.000	25.72	12.40	38.12	54.00	-15.88	AVG	189	188
9	10320.000	34.39	17.77	52.16	74.00	-21.84	peak	224	39
10	10320.000	25.49	17.77	43.26	54.00	-10.74	AVG	224	39
11	15480.000	23.48	22.30	45.78	74.00	-28.22	peak	200	266
12	15480.000	16.39	22.30	38.69	54.00	-15.31	AVG	200	266

Remarks:

1. Emission Level = Read Level + Factor (Antenna Factor + Cable Loss - Preamp Factor)
Margin value = Emission level – Limit value
2. The amplitude of spurious emissions attenuated more than 20 dB below the permissible value is not required to be report.
3. This data is tested under Bluetooth and Other 5G emission state.

Lab: [Hwa-Hsing \(Dongguan\) Testing Co., Ltd.](#)

Address: [No.101, Building N1, Yuyuan 2 Road, Yuyuan Industrial Park, HuangJiang Town, Dongguan City, People's Republic of China](#)

Tel: [0769-83078199](tel:0769-83078199)

Web.: www.hwa-hsing.com

E-Mail: customerservice.dg@hwa-hsing.com

Release

[Ver. 1.5](#)



Frequency Range	1GHz ~ 25GHz	Detector Function	Peak (PK) Average (AVG)
Test Channel	2441MHz+5160MHz		

Antenna Polarity & Test Distance: Horizontal at 3 m

No.	Frequency (MHz)	Reading (dBuV)	Factor (dB)	Emission Level (dBuV/m)	Limit (dBuV/m)	Margin (dB)	Detector	Antenna Height (cm)	Table Angle (Degree)
1#	2441.000	104.59	-0.30	104.29			peak	201	194
2#	2441.000	86.02	-0.30	85.72			AVG	201	194
3	4882.000	54.06	6.27	60.33	74.00	-13.67	peak	263	51
4	4882.000	43.85	6.27	50.12	54.00	-3.88	AVG	263	51
5#	5160.000	98.65	8.18	106.83			peak	174	21
6#	5160.000	77.13	8.18	85.31			AVG	174	21
7	7323.000	32.64	12.65	45.29	74.00	-28.71	peak	208	168
8	7323.000	23.77	12.65	36.42	54.00	-17.58	AVG	208	168
9	10320.000	37.31	17.77	55.08	74.00	-18.92	peak	167	126
10	10320.000	28.01	17.77	45.78	54.00	-8.22	AVG	167	126
11	15480.000	24.03	22.30	46.33	74.00	-27.67	peak	234	260
12	15480.000	19.86	22.30	42.16	54.00	-11.84	AVG	234	260

Antenna Polarity & Test Distance: Vertical at 3 m

No.	Frequency (MHz)	Reading (dBuV)	Factor (dB)	Emission Level (dBuV/m)	Limit (dBuV/m)	Margin (dB)	Detector	Antenna Height (cm)	Table Angle (Degree)
1#	2441.000	105.19	-0.30	104.89			peak	110	214
2#	2441.000	84.62	-0.30	84.32			AVG	110	214
3	4882.000	48.94	6.27	55.21	74.00	-18.79	peak	127	212
4	4882.000	36.99	6.27	43.26	54.00	-10.74	AVG	127	212
5#	5160.000	99.14	8.18	107.32			peak	132	287
6#	5160.000	76.09	8.18	84.27			AVG	132	287
7	7323.000	33.68	12.65	46.33	74.00	-27.67	peak	155	278
8	7323.000	23.11	12.65	35.76	54.00	-18.24	AVG	155	278
9	10320.000	36.25	17.77	54.02	74.00	-19.98	peak	106	299
10	10320.000	24.27	17.77	42.04	54.00	-11.96	AVG	106	299
11	15480.000	19.33	22.30	41.63	74.00	-32.37	peak	145	195
12	15480.000	16.96	22.30	39.26	54.00	-14.74	AVG	145	195

Remarks:

1. Emission Level = Read Level + Factor (Antenna Factor + Cable Loss - Preamp Factor)
Margin value = Emission level – Limit value
2. The amplitude of spurious emissions attenuated more than 20 dB below the permissible value is not required to be report.
3. This data is tested under Bluetooth and Other 5G emission state.

Lab: [Hwa-Hsing \(Dongguan\) Testing Co., Ltd.](#)

Address: [No.101, Building N1, Yuyuan 2 Road, Yuyuan Industrial Park, HuangJiang Town, Dongguan City, People's Republic of China](#)

Tel: [0769-83078199](tel:0769-83078199)

Web.: www.hwa-hsing.com

E-Mail: customerservice.dg@hwa-hsing.com

Release

[Ver. 1.5](#)



Frequency Range	1GHz ~ 25GHz	Detector Function	Peak (PK) Average (AVG)
Test Channel	2480MHz+5160MHz		

Antenna Polarity & Test Distance: Horizontal at 3 m									
No.	Frequency (MHz)	Reading (dBuV)	Factor (dB)	Emission Level (dBuV/m)	Limit (dBuV/m)	Margin (dB)	Detector	Antenna Height (cm)	Table Angle (Degree)
1#	2480.000	105.90	-0.21	105.69			peak	228	59
2#	2480.000	84.57	-0.21	84.36			AVG	228	59
3	4960.000	53.16	6.16	59.32	74.00	-14.68	peak	200	263
4	4960.000	43.00	6.16	49.16	54.00	-4.84	AVG	200	263
5#	5160.000	94.84	8.18	103.02			peak	165	337
6#	5160.000	76.08	8.18	84.26			AVG	165	337
7	7440.000	33.87	12.91	46.78	74.00	-27.22	peak	178	53
8	7440.000	22.31	12.91	35.22	54.00	-18.78	AVG	178	53
9	10320.000	36.51	17.77	54.28	74.00	-19.72	peak	236	167
10	10320.000	28.61	17.77	46.38	54.00	-7.62	AVG	236	167
11	15480.000	22.86	22.30	45.16	74.00	-28.84	peak	254	212
12	15480.000	20.92	22.30	43.22	54.00	-10.78	AVG	254	212

Antenna Polarity & Test Distance: Vertical at 3 m									
No.	Frequency (MHz)	Reading (dBuV)	Factor (dB)	Emission Level (dBuV/m)	Limit (dBuV/m)	Margin (dB)	Detector	Antenna Height (cm)	Table Angle (Degree)
1#	2480.000	105.84	-0.21	105.63			peak	120	245
2#	2480.000	85.47	-0.21	85.26			AVG	120	245
3	4960.000	46.15	6.16	52.31	74.00	-21.69	peak	113	40
4	4960.000	42.50	6.16	48.66	54.00	-5.34	AVG	113	40
5#	5160.000	98.05	8.18	106.23			peak	108	353
6#	5160.000	75.08	8.18	83.26			AVG	108	353
7	7440.000	32.35	12.91	45.26	74.00	-28.74	peak	136	344
8	7440.000	23.37	12.91	36.28	54.00	-17.72	AVG	136	344
9	10320.000	37.29	17.77	55.06	74.00	-18.94	peak	146	224
10	10320.000	25.39	17.77	43.16	54.00	-10.84	AVG	146	224
11	15480.000	21.90	22.30	44.20	74.00	-29.80	peak	155	174
12	15480.000	16.35	22.30	38.65	54.00	-15.35	AVG	155	174

Remarks:

1. Emission Level = Read Level + Factor (Antenna Factor + Cable Loss - Preamp Factor)
Margin value = Emission level – Limit value
2. The amplitude of spurious emissions attenuated more than 20 dB below the permissible value is not required to be report.
3. This data is tested under Bluetooth and Other 5G emission state.

Lab: [Hwa-Hsing \(Dongguan\) Testing Co., Ltd.](#)
 Address: [No.101, Building N1, Yuyuan 2 Road, Yuyuan Industrial Park, Huangjiang Town, Dongguan City, People's Republic of China](#)

Tel: [0769-83078199](tel:0769-83078199)
 Web.: www.hwa-hsing.com
 E-Mail: customerservice.dg@hwa-hsing.com

Release
 Ver. 1.5



3.2 Conducted emission measurement

3.2.1 Limits of Conducted Emission Measurement

Frequency (MHz)	Conducted Limit (dBuV)	
	Quasi-peak	Average
0.15 - 0.5	66 - 56	56 - 46
0.50 - 5.0	56	46
5.0 - 30.0	60	50

Note: 1. The lower limit shall apply at the transition frequencies.
2. The limit decreases in line with the logarithm of the frequency in the range of 0.15 to 0.50MHz.

3.2.2 Test Instruments

Description	Manufacturer	Model No.	Serial No.	Due Date of Calibration
EMI Test Receiver	Rohde&Schwarz	ESR7	101961	2023-12-27
Artificial Mains Network	Rohde&Schwarz	ENV216	3560.6550.15	2023-12-27
Test software	FARAD	EZ_EMV V1.1.4.2	N/A	N/A

Note: 1. The calibration interval of the above test instruments is 12 months.
2. The test was performed in Shielded Room.



3.2.3 Test Procedures

- The EUT was placed 0.4 meters from the conducting wall of the shielded room with EUT being connected to the power mains through a line impedance stabilization network (LISN). Other support units were connected to the power mains through another LISN. The two LISNs provide 50 ohm/ 50uH of coupling impedance for the measuring instrument.
- Both lines of the power mains connected to the EUT were checked for maximum conducted interference.
- The frequency range from 150kHz to 30MHz was searched. Emission levels under (Limit – 20dB) was not recorded.

Note: All modes of operation were investigated and the worst-case emissions are reported.

3.2.4 Test Setup

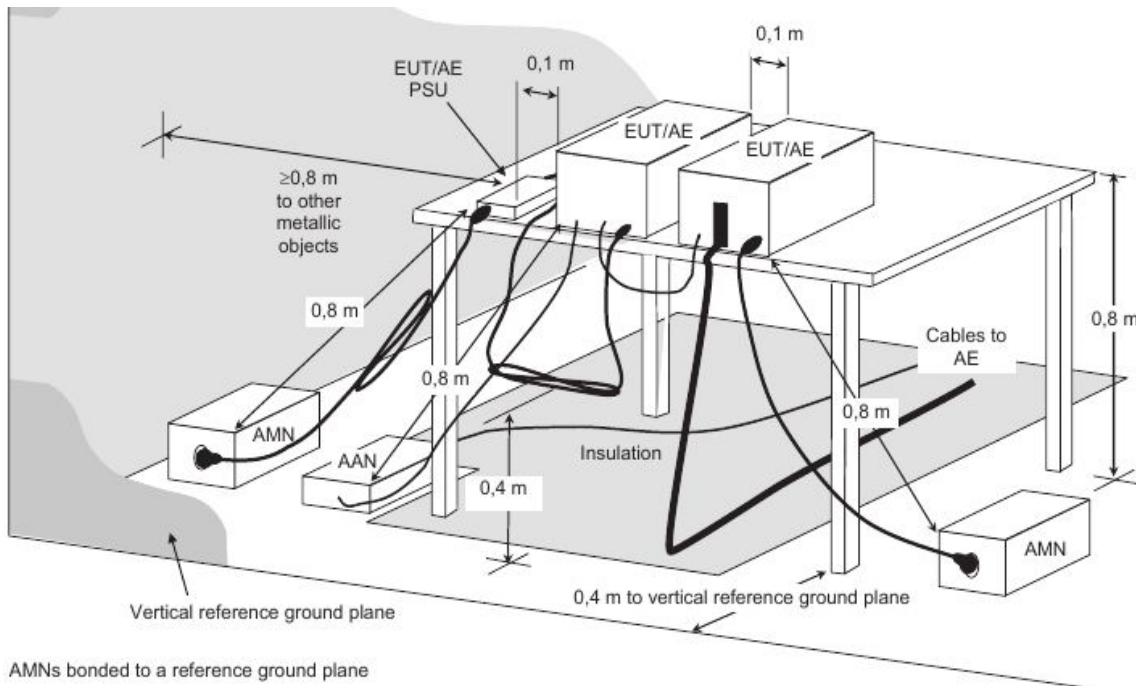

For the actual test configuration, please refer to the attached file (Test Setup Photo).

3.2.5 EUT Operating Condition

Set the EUT under transmission condition continuously at specific channel frequency.

3.2.6 Deviation from Test Standard

No deviation.



3.2.7 Test Results

Frequency Range	150kHz ~ 30MHz	Detector Function & Resolution andwidth	Quasi-Peak (QP) / Average (AV), 9kHz
-----------------	----------------	---	--------------------------------------

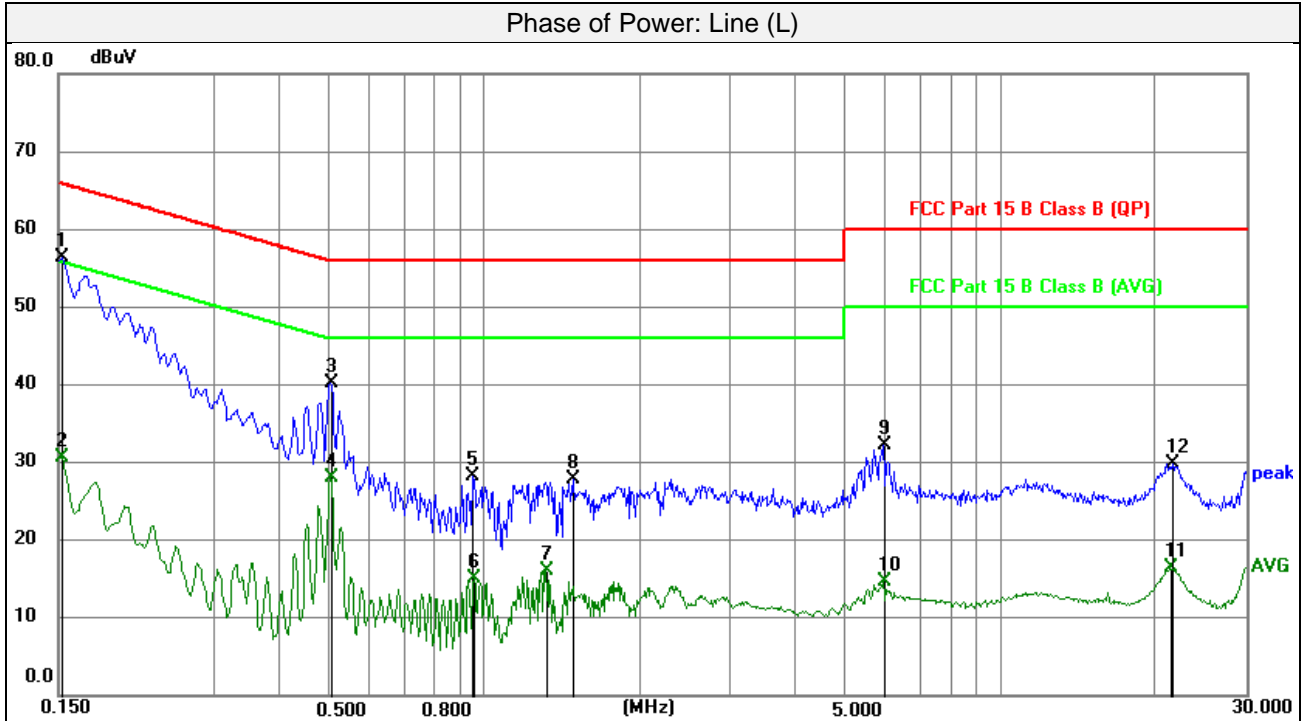

No.	Frequency	Reading	Correction Factor	Emission Level	Limit	Margin	Remark
	(MHz)	(dBuV)	dB	(dBuV)	(dBuV)	(dB)	Detector
1	0.1522	46.17	10.18	56.35	65.88	-9.53	peak
2	0.1522	20.54	10.18	30.72	55.88	-25.16	AVG
3	0.5055	30.16	10.10	40.26	56.00	-15.74	peak
4	0.5055	17.98	10.10	28.08	46.00	-17.92	AVG
5	0.9577	18.18	10.04	28.22	56.00	-27.78	peak
6	0.9600	5.01	10.04	15.05	46.00	-30.95	AVG
7	1.3178	6.10	10.05	16.15	46.00	-29.85	AVG
8	1.4910	17.73	10.06	27.79	56.00	-28.21	peak
9	5.9393	22.30	10.00	32.30	60.00	-27.70	peak
10	5.9393	4.75	10.00	14.75	50.00	-35.25	AVG
11	21.4823	6.00	10.37	16.37	50.00	-33.63	AVG
12	21.6104	19.51	10.37	29.88	60.00	-30.12	peak

Remarks:

1. Q.P. and AV. are abbreviations of quasi-peak and average individually.
2. The emission levels of other frequencies were very low against the limit.
3. Margin value = Emission level - Limit value
4. Correction factor = Insertion loss + Cable loss
5. Emission Level = Correction Factor + Reading Value.

Lab: [Hwa-Hsing \(Dongguan\) Testing Co., Ltd.](#)

Address: [No.101, Building N1, Yuyuan 2 Road, Yuyuan Industrial Park, HuangJiang Town, Dongguan City, People's Republic of China](#)

Tel: [0769-83078199](tel:0769-83078199)

Web.: www.hwa-hsing.com

E-Mail: customerservice.dg@hwa-hsing.com

Release

[Ver. 1.5](#)



Frequency Range	150kHz ~ 30MHz	Detector Function & Resolution bandwidth	Quasi-Peak (QP) / Average (AV), 9kHz
-----------------	----------------	--	--------------------------------------

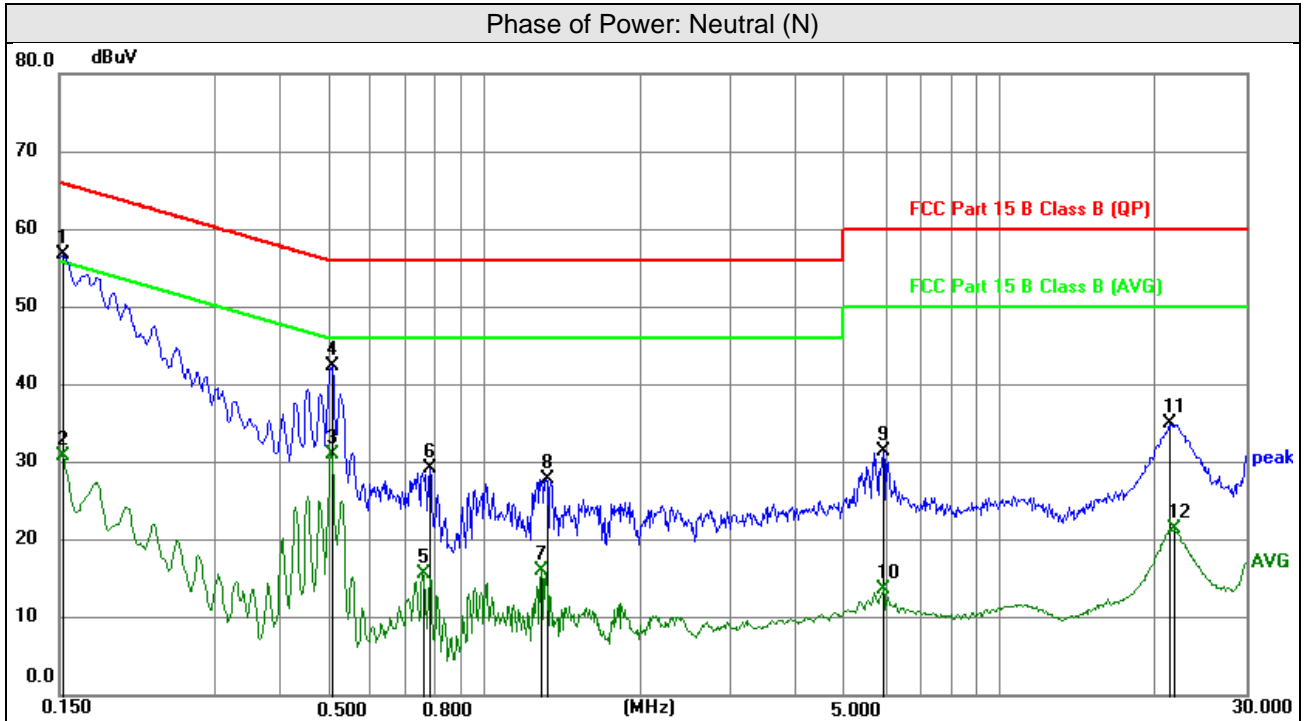

No.	Frequency (MHz)	Reading (dBuV)	Correct Factor (dB)	Emission Level (dBuV)	Limit (dBuV)	Margin (dB)	Remark
1	0.1522	46.61	10.18	56.79	65.88	-9.09	peak
2	0.1522	20.73	10.18	30.91	55.88	-24.97	AVG
3	0.5055	20.93	10.11	31.04	46.00	-14.96	AVG
4	0.5076	32.23	10.11	42.34	56.00	-13.66	peak
5	0.7620	5.60	10.09	15.69	46.00	-30.31	AVG
6	0.7867	19.05	10.08	29.13	56.00	-26.87	peak
7	1.2930	6.00	10.06	16.06	46.00	-29.94	AVG
8	1.3178	17.76	10.06	27.82	56.00	-28.18	peak
9	5.9415	21.48	9.99	31.47	60.00	-28.53	peak
10	5.9415	3.59	9.99	13.58	50.00	-36.42	AVG
11	21.3584	24.64	10.39	35.03	60.00	-24.97	peak
12	21.8153	10.99	10.40	21.39	50.00	-28.61	AVG

Remarks:

1. Q.P. and AV. are abbreviations of quasi-peak and average individually.
2. The emission levels of other frequencies were very low against the limit.
3. Margin value = Emission level - Limit value
4. Correction factor = Insertion loss + Cable loss
5. Emission Level = Correction Factor + Reading Value.

Lab: [Hwa-Hsing \(Dongguan\) Testing Co., Ltd.](#)

Address: [No.101, Building N1, Yuyuan 2 Road, Yuyuan Industrial Park, HuangJiang Town, Dongguan City, People's Republic of China](#)

Tel: [0769-83078199](tel:0769-83078199)

Web.: www.hwa-hsing.com

E-Mail: customerservice.dg@hwa-hsing.com

Release

[Ver. 1.5](#)



3.3 Number of Hopping Frequency Used

3.3.1 Limits of Hopping Frequency Used Measurement

At least 15 channels frequencies, and should be equally spaced.

3.3.2 Test Setup

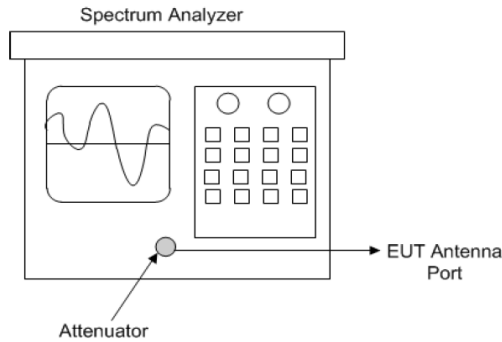

Spectrum analyzer test configuration

3.3.3 Test Instruments

Refer to section 5 to get information of above instrument.

3.3.4 Test Procedure

- Check the calibration of the measuring instrument (SA) using either an internal calibrator or a known signal from an external generator.
- Turn on the EUT and connect its antenna terminal to measurement via a low loss cable. Then set it to any one measured frequency within its operating range and make sure the instrument is operated in its linear range.
- Set the SA on MaxHold Mode, and then keep the EUT in hopping mode. Record all the signals from each channel until each one has been recorded.
- Set the SA on View mode and then plot the result on SA screen.
- Repeat above procedures until all frequencies measured were complete.

3.3.5 Deviation from Test Standard

No deviation.



3.3.6 Test Results

There are 79 hopping frequencies in the hopping mode. Please refer to next page for the test result. On the plots, it shows that the hopping frequencies are equally spaced.

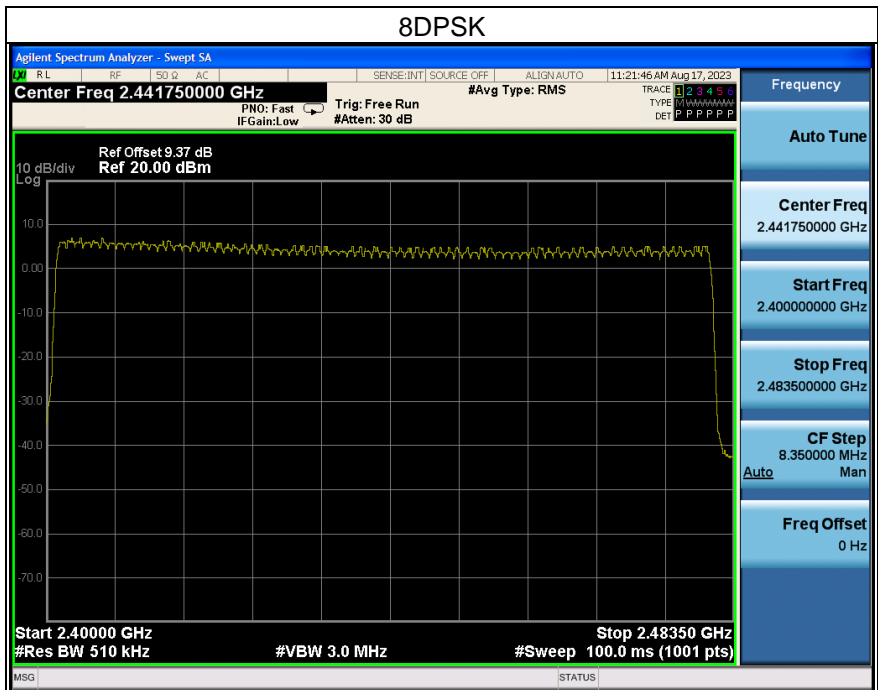
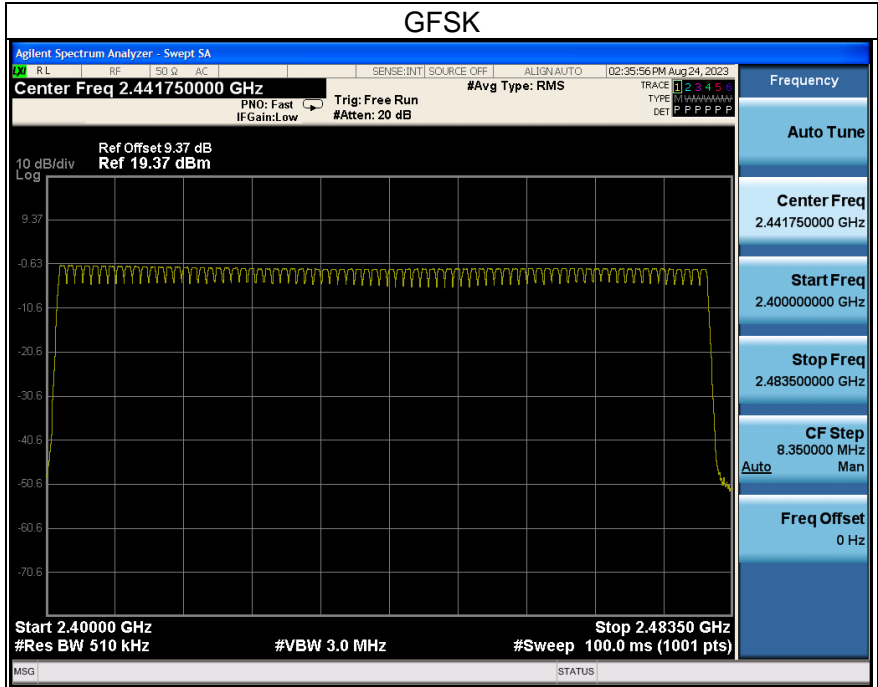



3.4 Dwell Time on Each Channel

3.4.1 Limits of Dwell Time on Each Channel Measurement

The average time of occupancy on any channel shall not be greater than 0.4 seconds within a period of 0.4 seconds multiplied by the number of hopping channels employed.

3.4.2 Test Setup

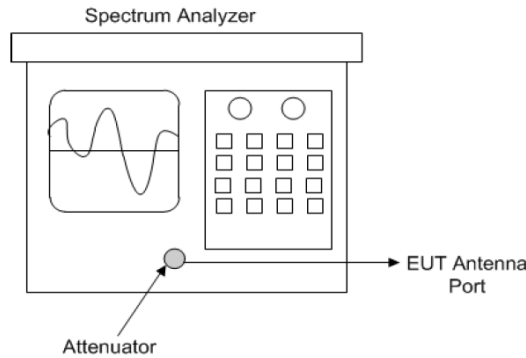

Spectrum analyzer test configuration

3.4.3 Test Instruments

Refer to section 5 to get information of above instrument.

3.4.4 Test Procedures

- Check the calibration of the measuring instrument (SA) using either an internal calibrator or a known signal from an external generator.
- Turn on the EUT and connect its antenna terminal to measurement via a low loss cable. Then set it to any one measured frequency within its operating range and make sure the instrument is operated in its linear range.
- Adjust the center frequency of SA on any frequency be measured and set SA to zero span mode. And then, set RBW and VBW of spectrum analyzer to proper value.
- Measure the time duration of one transmission on the measured frequency. And then plot the result with time difference of this time duration.
- Repeat above procedures until all different time-slot modes have been completed.

3.4.5 Deviation from Test Standard

No deviation.



3.4.6 Test Results

GFSK

Mode	Number of Hopping Channel	Number of transmission in a period (channel number*0.4 sec)				Length of transmission time (msec)	Result (msec)	Limit (msec)	Verdict
		Period (sec)	Sweep time (sec)	times in a sweep	times in a period				
DH1	79	31.6	3.16	32	320	0.372	119.168	400	Pass
DH3	79	31.6	3.16	16	160	1.619	259.040	400	Pass
DH5	79	31.6	3.16	11	110	2.868	315.480	400	Pass

Note: Test plots of the transmitting time slot are shown as below.

8DPSK

Mode	Number of Hopping Channel	Number of transmission in a period (channel number*0.4 sec)				Length of transmission time (msec)	Result (msec)	Limit (msec)	Verdict
		Period (sec)	Sweep time (sec)	times in a sweep	times in a period				
3DH1	79	31.6	3.16	33	330	0.380	125.400	400	Pass
3DH3	79	31.6	3.16	17	170	1.630	277.100	400	Pass
3DH5	79	31.6	3.16	11	110	2.882	317.020	400	Pass

Note: Test plots of the transmitting time slot are shown as below.

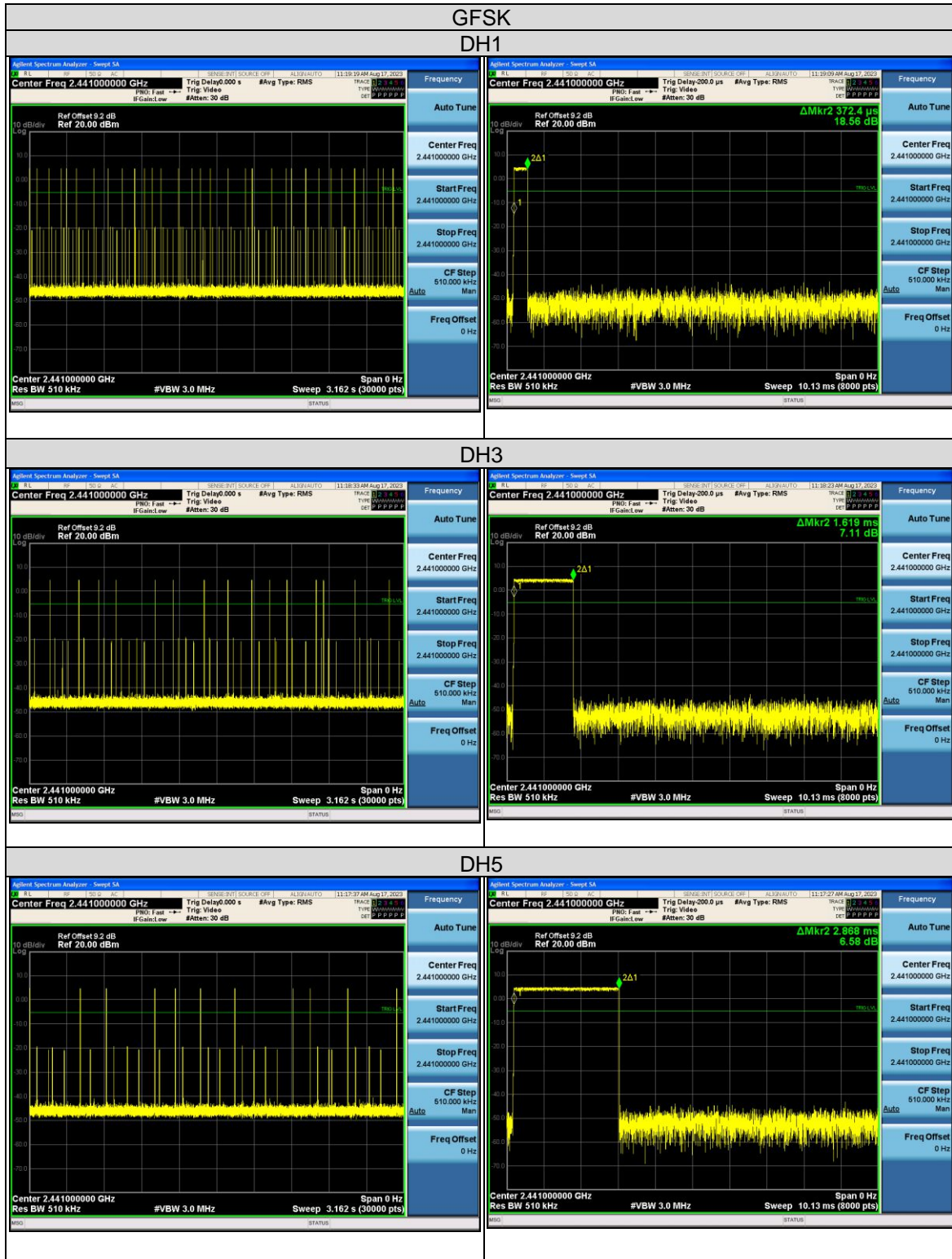

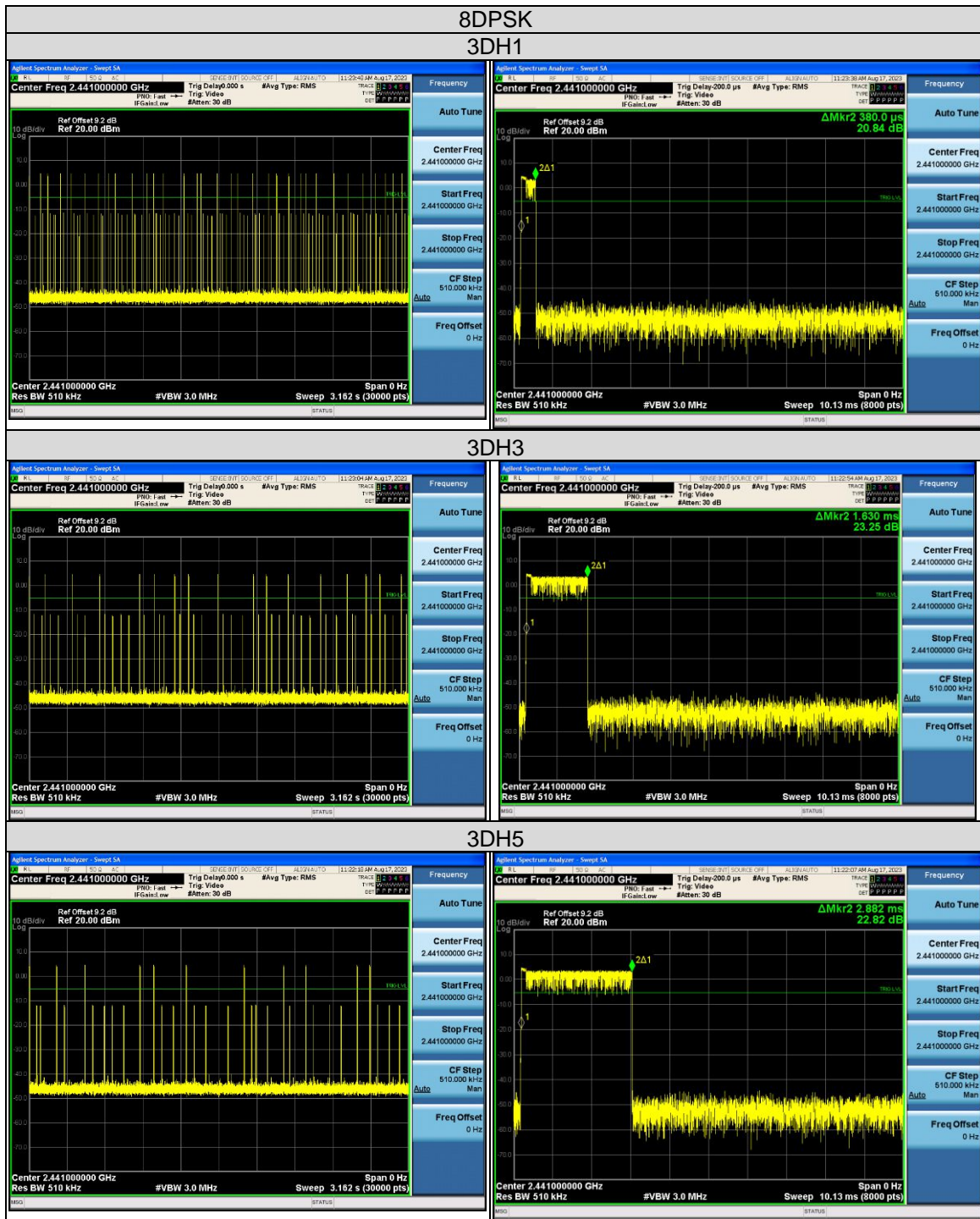

Lab: [Hwa-Hsing \(Dongguan\) Testing Co., Ltd.](#)
Address: [No.101, Building N1, Yuyuan 2 Road, Yuyuan Industrial Park, Huangjiang Town, Dongguan City, People's Republic of China](#)

Tel: [0769-83078199](tel:0769-83078199)
Web: www.hwa-hsing.com
E-Mail: customerservice.dg@hwa-hsing.com

Release
Ver. 1.5



3.5 Channel Bandwidth

3.5.1 Limits of Channel Bandwidth Measurement

For frequency hopping system operating in the 2400-2483.5 MHz, if the 20 dB bandwidth of hopping channel is greater than 25 kHz, two-thirds 20 dB bandwidth of hopping channel shall be a minimum limit for the hopping channel separation.

3.5.2 Test Setup

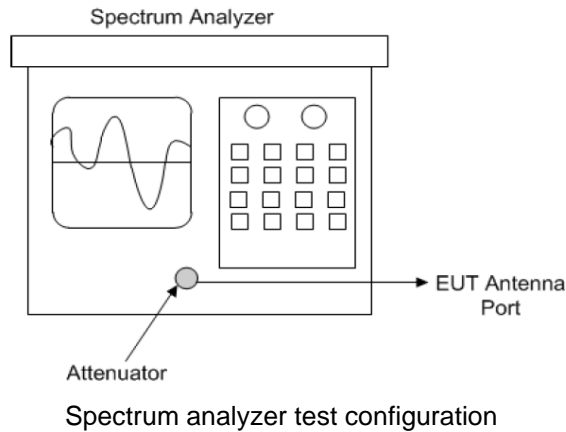

3.5.3 Test Instruments

Refer to section 5 to get information of above instrument.

3.5.4 Test Procedure

- Check the calibration of the measuring instrument using either an internal calibrator or a known signal from an external generator.
- Turn on the EUT and connect it to measurement instrument. Then set it to any one convenient frequency within its operating range. Set a reference level on the instrument equal to the highest peak value.
- Measure the frequency difference of two frequencies that were attenuated 20 dB from the reference level. Record the frequency difference as the emission bandwidth.
- Repeat above procedures until all frequencies measured were complete.

3.5.5 Deviation from Test Standard

No deviation.

3.5.6 EUT Operating Condition

The software provided by client enabled the EUT to transmit and receive data at lowest, middle and highest channel frequencies individually.

Lab: [Hwa-Hsing \(Dongguan\) Testing Co., Ltd.](#)

Address: [No.101, Building N1, Yuyuan 2 Road, Yuyuan Industrial Park, HuangJiang Town, Dongguan City, People's Republic of China](#)

Tel: [0769-83078199](#)

Web.: [www.hwa-hsing.com](#)

E-Mail: customerservice.dg@hwa-hsing.com

Release
Ver. 1.5



3.5.7 Test Results

Channel	Frequency (MHz)	20dB Bandwidth (MHz)	
		GFSK	8DPSK
0	2402	1.017	1.266
39	2441	0.966	1.257
78	2480	1.032	1.251

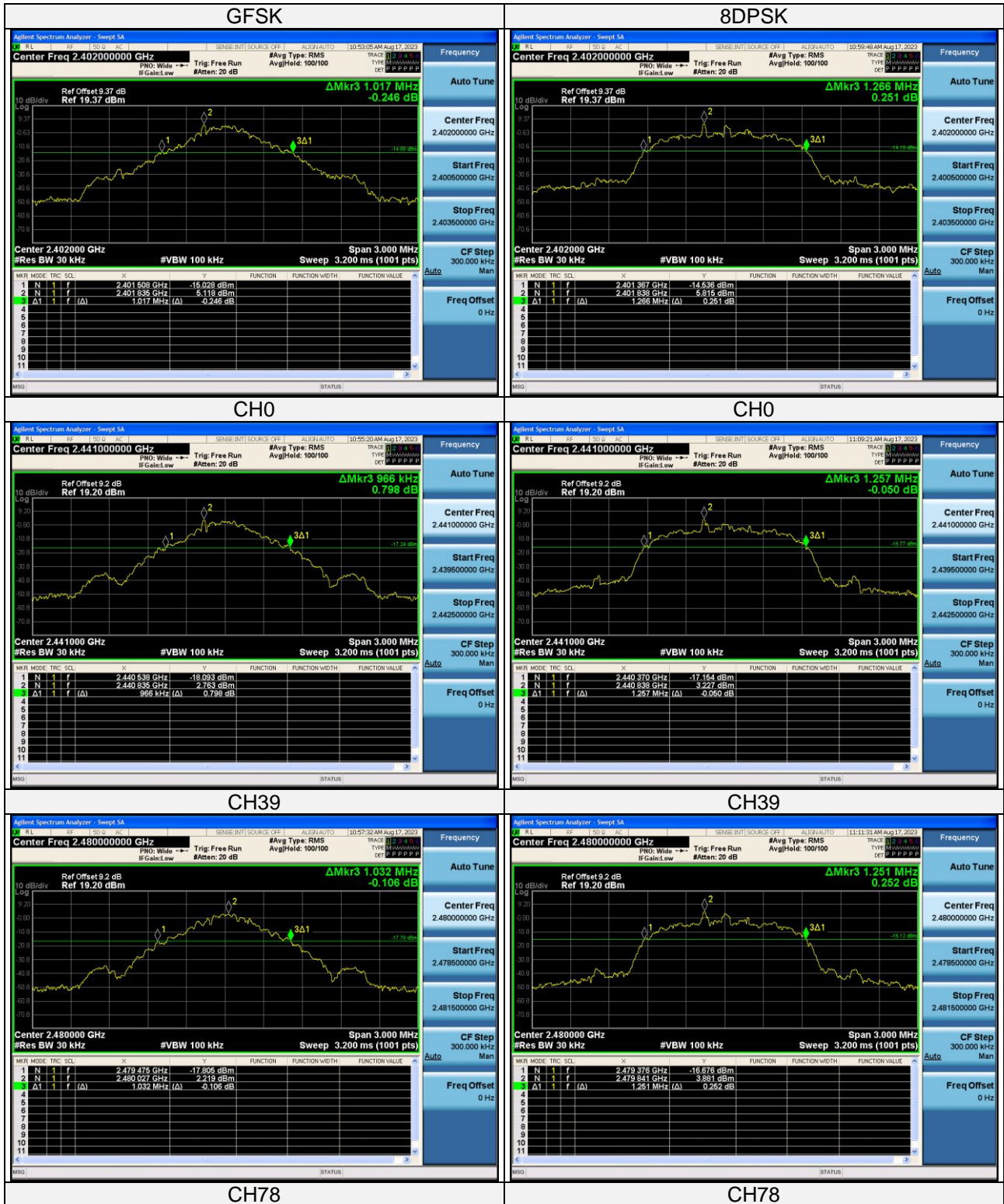



3.6 Occupied Bandwidth Measurement

3.6.1 Test Setup

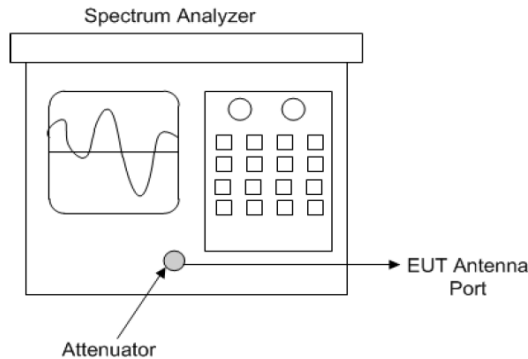

Spectrum analyzer test configuration

3.6.2 Test Instruments

Refer to section 5 to get information of above instrument

3.6.3 Test Procedure

The transmitter output was connected to the spectrum analyzer through an attenuator. The bandwidth of the fundamental frequency was measured by spectrum analyzer with resolution bandwidth in the range of 1% to 5% of the anticipated emission bandwidth, and a video bandwidth at least 3x the resolution bandwidth and set the detector to PEAK. The width of a frequency band such that, below the lower and above the upper frequency limits, the mean powers emitted are each equal to a specified percentage 0.5% of the total mean power of a given emission.

3.6.4 Deviation from Test Standard

No deviation.

3.6.5 EUT Operating Conditions

The software provided by client to enable the EUT under transmission condition continuously at lowest, middle and highest channel frequencies individually.



3.6.6 Test Results

Channel	Frequency (MHz)	Occupied Bandwidth (MHz)	
		GFSK	8DPSK
0	2402	0.91585	1.1962
39	2441	0.91005	1.1634
78	2480	0.89584	1.1636





3.7 Hopping Channel Separation

3.7.1 Limits of Hopping Channel Separation Measurement

At least 25 kHz or two-third of 20 dB hopping channel bandwidth (whichever is greater).

3.7.2 Test Setup

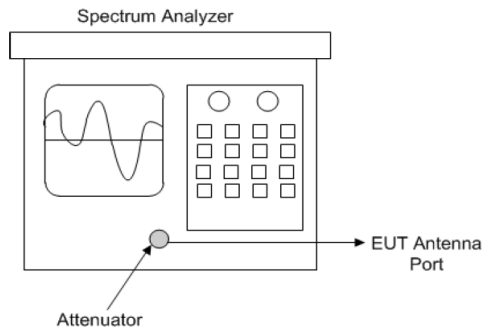

3.7.3 Test Instruments

Refer to section 5 to get information of above instrument.

3.7.4 Test Procedure

- Check the calibration of the measuring instrument using either an internal calibrator or a known signal from an external generator.
- Turn on the EUT and connect it to measurement instrument. Then set it to any one convenient frequency within its operating range.
- By using the MaxHold function record the separation of two adjacent channels.
- Measure the frequency difference of these two adjacent channels by SA MARK function. And then plot the result on SA screen.
- Repeat above procedures until all frequencies measured were complete.

3.7.5 Deviation from Test Standard

No deviation.



3.7.6 Test Results

Channel No.	Frequency (MHz)	Adjacent Channel Separation (MHz)		Minimum Limit (MHz)		Pass / Fail
		GFSK	8DPSK	GFSK	8DPSK	
0	2402	1.011	1.002	0.678	0.844	Pass
39	2441	0.993	1.002	0.644	0.838	Pass
78	2480	0.987	0.999	0.688	0.834	Pass

Note: The minimum limit is two-third 20 dB bandwidth.



Lab: [Hwa-Hsing \(Dongguan\) Testing Co., Ltd.](#)
 Address: [No.101, Building N1, Yuyuan 2 Road, Yuyuan Industrial Park, Huangjiang Town, Dongguan City, People's Republic of China](#)

Tel: [0769-83078199](tel:0769-83078199)
 Web.: www.hwa-hsing.com
 E-Mail: customerservice.dg@hwa-hsing.com

Release
 Ver. 1.5



3.8 Maximum Output Power

3.8.1 Limits of Maximum Output Power Measurement

The Maximum Output Power Measurement is 125mW.

3.8.2 Test Setup

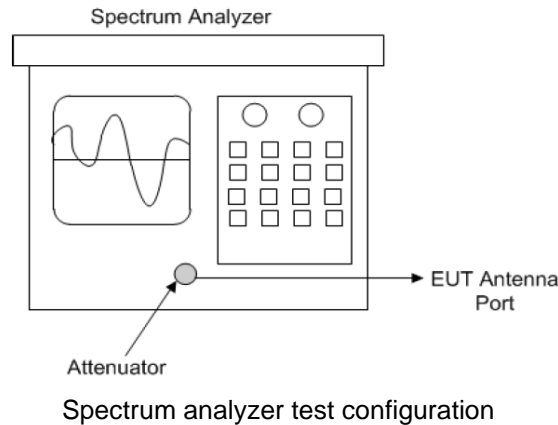

3.8.3 Test Instruments

Refer to section 5 to get information of above instrument.

3.8.4 Test Procedure

Measurement using a spectrum analyzer (SA), Selection of test method:

The proper test method is selected based on the following criteria:

- a) **Method AVGSA-1 or method AVGSA-1A (alternative)** shall be applied if either of the following conditions can be satisfied:
 - 1) The EUT transmits continuously (or with a D> 98%).
 - 2) Sweep triggering can be implemented in such a way that the device transmits at the maximum power control level throughout the duration of each of the instrument sweeps to be averaged. This condition can generally be achieved by triggering the instrument's sweep if the duration of the sweep (with the instrument configured as in method AVGSA-1) is equal to or shorter than the duration T of each transmission from the EUT, and if those transmissions exhibit full power throughout their durations.
- b) **Method AVGSA-2 or method AVGSA-2A (alternative)** shall be applied if the conditions of the preceding item a) cannot be achieved and the transmissions exhibit a constant duty cycle during the measurement duration. Duty cycle will be considered to be constant if variations are less than +2%.
- c) **Method AVGSA-3 or method AVGSA-3A (alternative)** shall be applied if the conditions of the preceding item a) and item b) cannot be achieved.



Measurement using a spectrum analyzer (SA), Selection of test method:

Maximum peak conducted output power

The following procedure shall be used when an instrument with a resolution bandwidth that is greater than the DTS bandwidth is available to perform the measurement:

- a) Set the RBW > DTS bandwidth.
- b) Set VBW > [3 x RBW]
- c) Set span > [3 x RBW]
- d) Sweep time = auto couple.
- e) Detector = peak
- f) Trace mode = max hold.
- g) Allow trace to fully stabilize.
- h) Use peak marker function to determine the peak amplitude level.



- Maximum conducted (average) output power (Method AVGSA-2).
- a) Check the calibration of the measuring instrument using either an internal calibrator or a known signal from an external generator.
 - b) Turn on the EUT and connect it to measurement instrument. Then set it to any one convenient frequency within its operating range. Set a reference level on the measuring instrument equal to the highest peak value.
 - c) SA Setting:
 - 1)* Set span to at least 1.5 times the OBW
 - 2)* Set sweep to "free run."
 - 3)* Set RBW= 1% to 5% of the OBW. not to exceed 1MHz.
 - 4)* Set VBW $\geq 3 \times$ RBW
 - 5)* Number of points in sweep $\geq 2 \times$ span /RBW. (This gives bin-to-bin spacing \leq RBW / 2. so that narrowband signals are not lost between frequency bins).
 - 6)* Sweep time =auto
 - 7)* Detector =RMS (power averaging).
 - 8)* Trace average at least 100 traces in power averaging (rms) mode; however, the number of traces to be averaged shall be increased above 100 as needed such that the average accurately represents the true average over the ON and OFF periods of the transmitter.
 - 9)* Compute power by integrating the spectrum across the OBW of the signal using the instrument's band power measurement function with band limits set equal to the OBW band edges. If the instrument does not have a band power function, then sum the spectrum levels (in power units) at intervals equal to the RBW extending across the entire OBW of the spectrum.
 - 10)* Compute power by integrating the spectrum across the OBW of the signal using the instrument's band power measurement function with band limits set equal to the OBW band edges. If the instrument does not have a band power function. then sum the spectrum levels (in power units) at intervals equal to the RBW extending across the entire OBW.
 - 11)* Add $[10 \log (1/ D)]$, where D is the duty cycle, to the measured power to compute the average power during the actual transmission times (because the measurement represents an average over both the ON and OFF times of the transmission).
 - d. Measure the captured power within the band and recording the plot.
 - e. Repeat above procedures until all frequencies required were complete.

3.8.5 Deviation from Test Standard

No deviation.

3.8.6 EUT Operating Condition

The software provided by client enabled the EUT to transmit and receive data at lowest, middle and highest channel frequencies individually.



3.8.7 Test Results

Peak power

Channel No.	Freq. (MHz)	Output Power (dBm)		Output Power (mW)		Power Limit (mW)	Pass / Fail
		GFSK	8DPSK	GFSK	8DPSK		
0	2402	7.160	8.200	5.200	6.607	125	Pass
39	2441	4.900	6.110	3.090	4.083	125	Pass
78	2480	5.090	6.300	3.228	4.266	125	Pass

Average power

Channel No.	Freq. (MHz)	Output Power (dBm)		Output Power (mW)		Power Limit (mW)	Pass / Fail
		GFSK	8DPSK	GFSK	8DPSK		
0	2402	6.51	5.23	4.479	3.331	125	Pass
39	2441	4.55	3.00	2.852	1.994	125	Pass
78	2480	4.91	3.30	3.099	2.136	125	Pass

Note: The final results of average power should add the duty cycle factor [10 log (1/ D)].



Peak Power Spectrum Plot

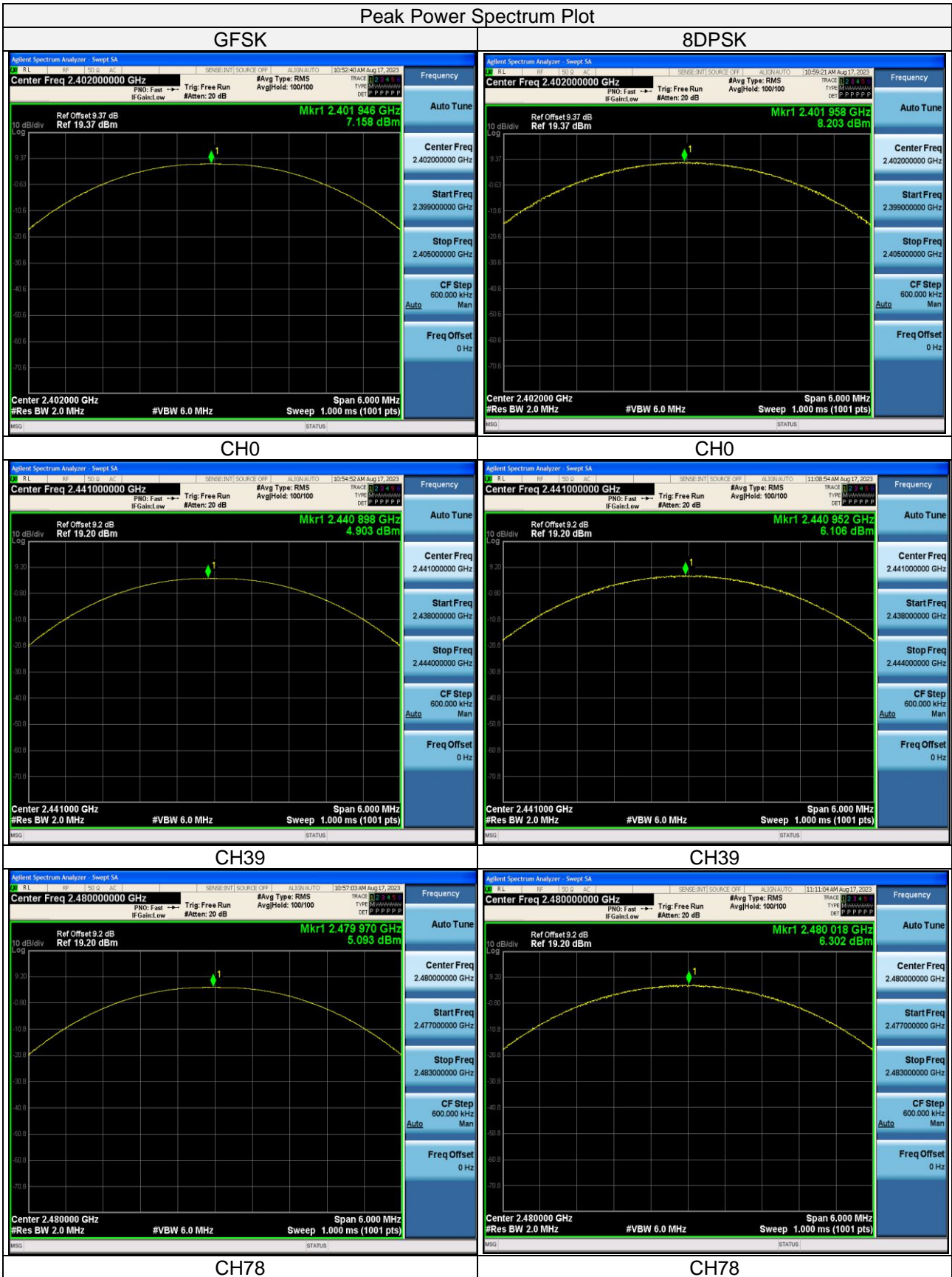

Lab: [Hwa-Hsing \(Dongguan\) Testing Co., Ltd.](#)
 Address: [No.101, Building N1, Yuyuan 2 Road, Yuyuan Industrial Park, Huangjiang Town, Dongguan City, People's Republic of China](#)

Tel: [0769-83078199](tel:0769-83078199)
 Web.: www.hwa-hsing.com
 E-Mail: customerservice.dg@hwa-hsing.com

Release Ver. 1.5



Average Power Spectrum Plot

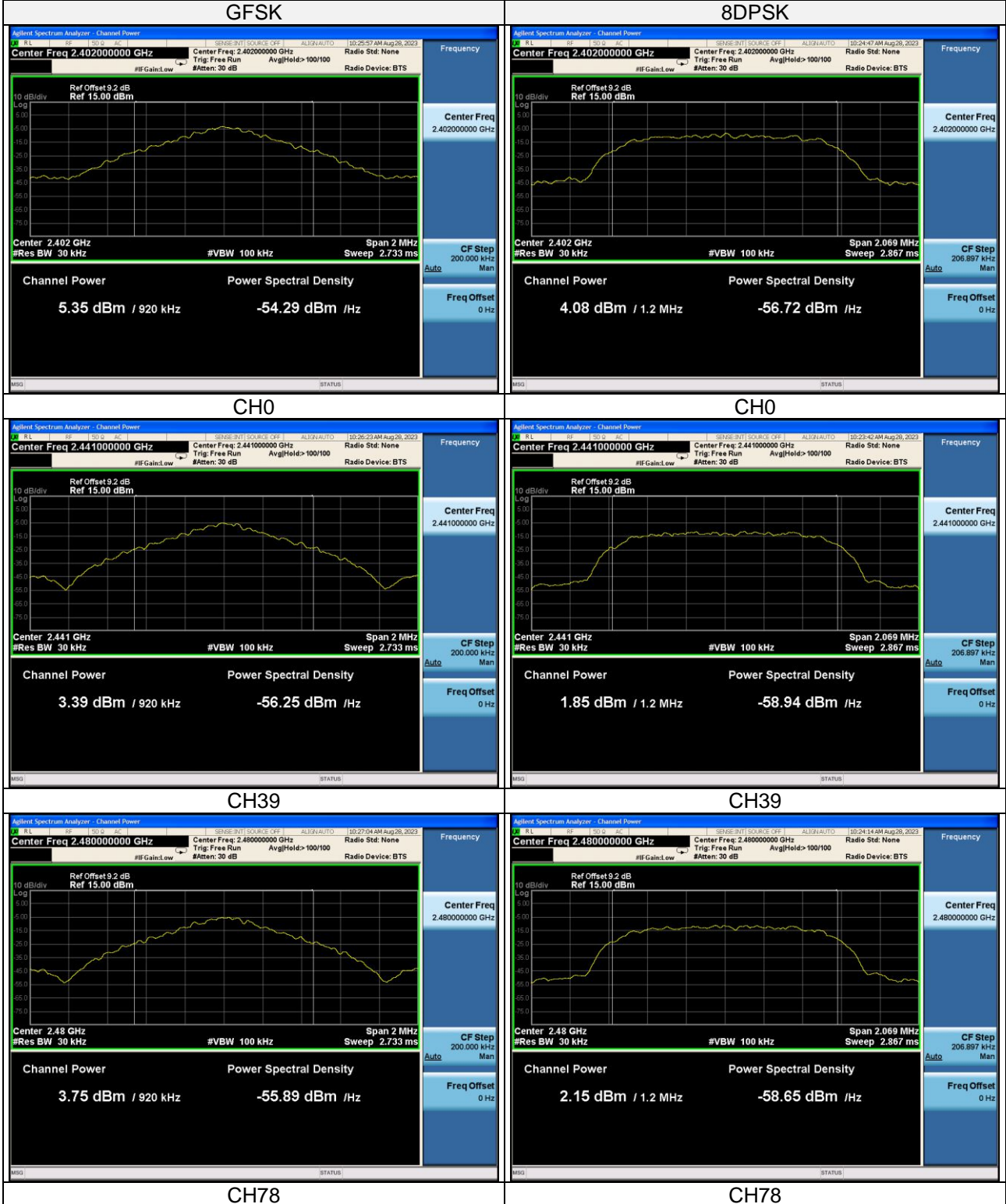



3.9 Conducted Out of Band Emission Measurement

3.9.1 Limits of Conducted Out of Band Emission Measurement

- a. **If the maximum peak conducted output power procedure was used to determine compliance as described in 11.9.1**, then the peak output power measured in any 100 kHz bandwidth outside of the authorized frequency band shall be attenuated by at least 20 dB relative to the maximum in-band peak PSD level in 100 kHz (i.e., 20 dBc).
- b. **If maximum conducted (average) output power was used to determine compliance as described in 11.9.2**, then the peak power in any 100 kHz bandwidth outside of the authorized frequency band shall be attenuated by at least 30 dB relative to the maximum in-band peak PSD level in 100 kHz (i.e., 30 dBc)

3.9.2 Test Setup

- DTS emissions in non-restricted frequency bands Subclause 11.11 of ANSI C63.10 is applicable.
- DTS emissions in restricted frequency bands Subclause 11.12 of ANSI C63.10 is applicable

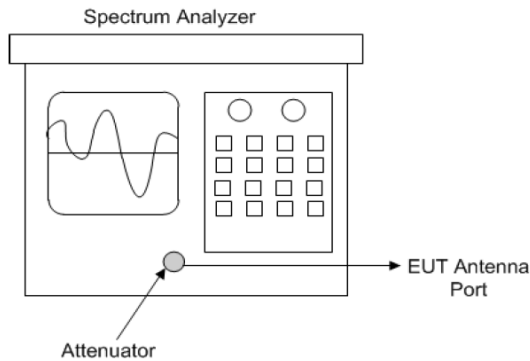

Spectrum analyzer test configuration

3.9.3 Test Instruments

Refer to section 5 to get information of above instrument.



3.9.4 Test Procedure

- a. Establish a reference level by using the following procedure:
 - 1) Set instrument center frequency to DTS channel center frequency.
 - 2) Set the span to 21.5 times the DTS bandwidth)
 - 3) Set the RBW= 100 kHz)
 - 4) Set the VBW $\geq 3 \times$ RBW
 - 5) Detector = peak
 - 6) Sweep time = auto coupling
 - 7) Trace mode =max hold
 - 8) Allow trace to fully stabilize
 - 9) Use the peak marker function to determine the maximum PSD level.

Note that the channel found to contain the maximum PSD level can be used to establish the reference level.

- b. Establish an emission level by using the following procedure:
 - 1) Set the center frequency and span to encompass frequency range to be measured.
 - 2) Set the RBW = 100 kHz
 - 3) Set the VBW ≥ 300 kHz.
 - 4) Detector = peak.
 - 5) Sweep time = auto couple.
 - 6) Trace mode = max hold.
 - 7) Allow trace to fully stabilize.
 - 8) Use the peak marker function to determine the maximum power level in any 100 kHz band segment within the fundamental EBW.

3.9.5 Deviation from Test Standard

No deviation.

3.9.6 EUT Operating Condition

The software provided by client enabled the EUT to transmit and receive data at lowest, middle and highest channel frequencies individually.



3.9.7 Test Results

The spectrum plots are attached on the following images. D1 line indicates the highest level, D2 line indicates the 20dB offset below D1. It shows compliance with the requirement.

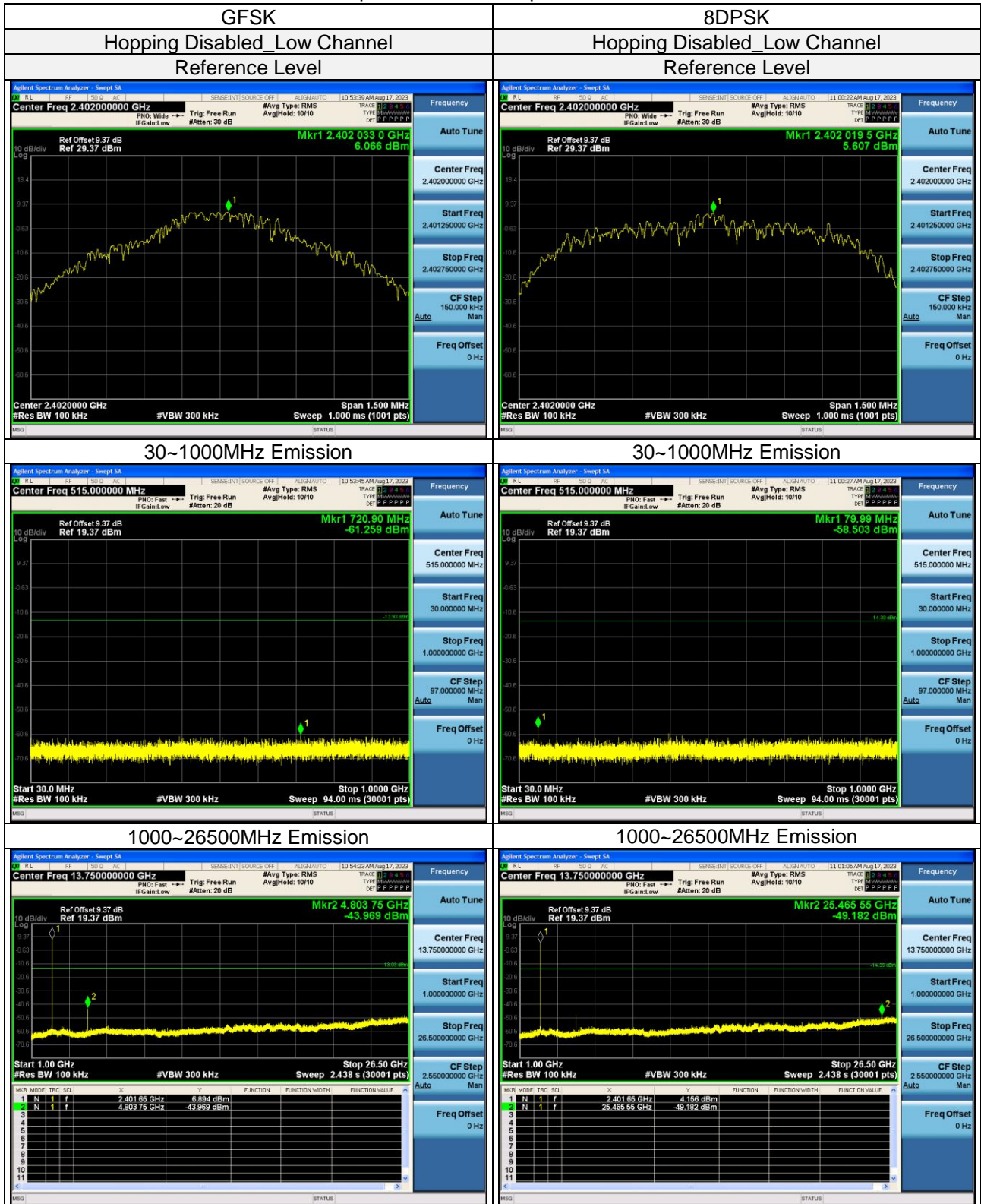

Lab: [Hwa-Hsing \(Dongguan\) Testing Co., Ltd.](http://www.hwa-hsing.com)
 Address: [No.101, Building N1, Yuyuan 2 Road, Yuyuan Industrial Park, Huangjiang Town, Dongguan City, People's Republic of China](http://www.hwa-hsing.com)

Tel: [0769-83078199](tel:0769-83078199)
 Web: www.hwa-hsing.com
 E-Mail: customerservice.dg@hwa-hsing.com

Release
 Ver. 1.5

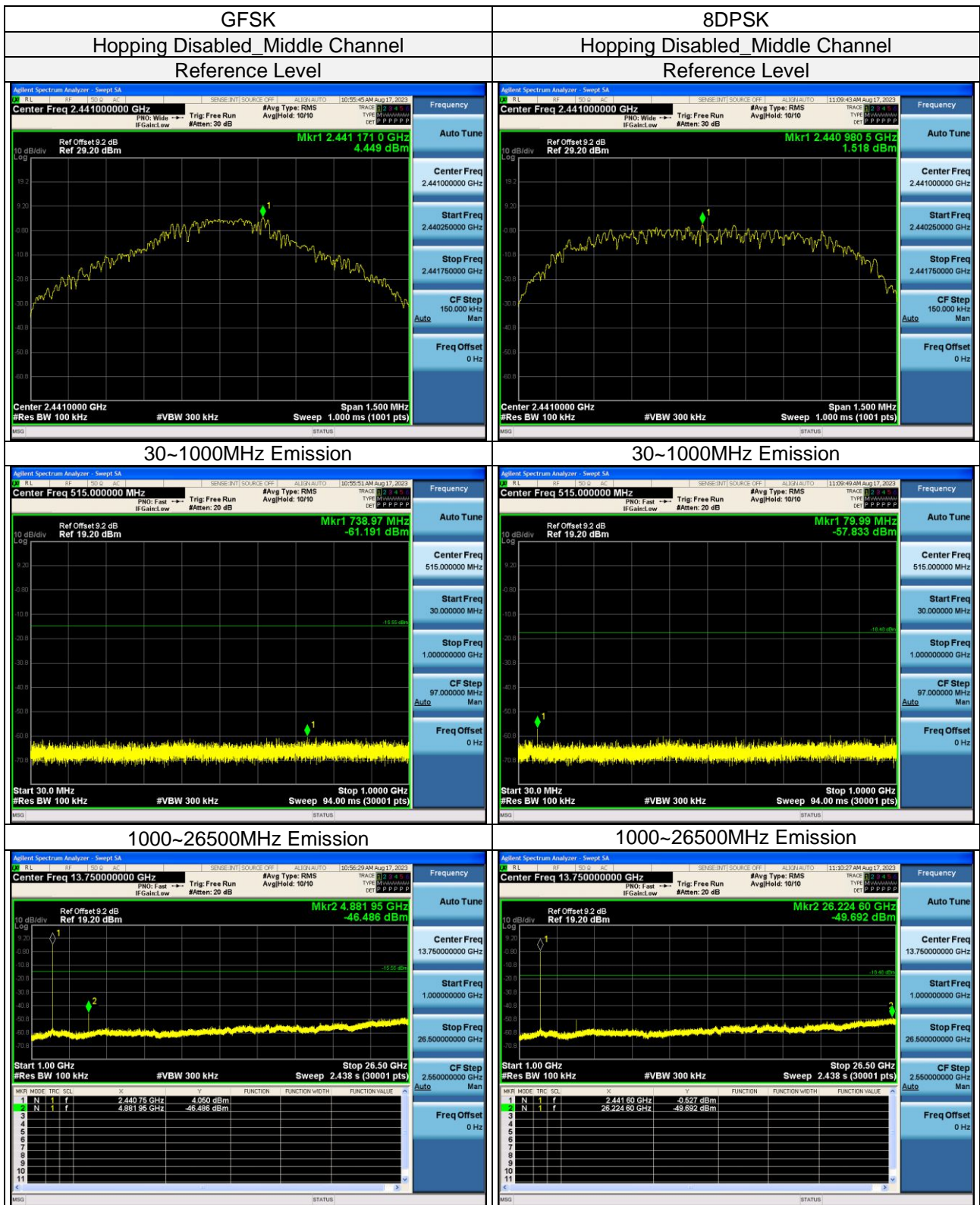

Lab: [Hwa-Hsing \(Dongguan\) Testing Co., Ltd.](#)
 Address: [No.101, Building N1, Yuyuan 2 Road, Yuyuan Industrial Park, Huangjiang Town, Dongguan City, People's Republic of China](#)

Tel: [0769-83078199](tel:0769-83078199)
 Web.: www.hwa-hsing.com
 E-Mail: customerservice.dg@hwa-hsing.com

Release Ver. 1.5

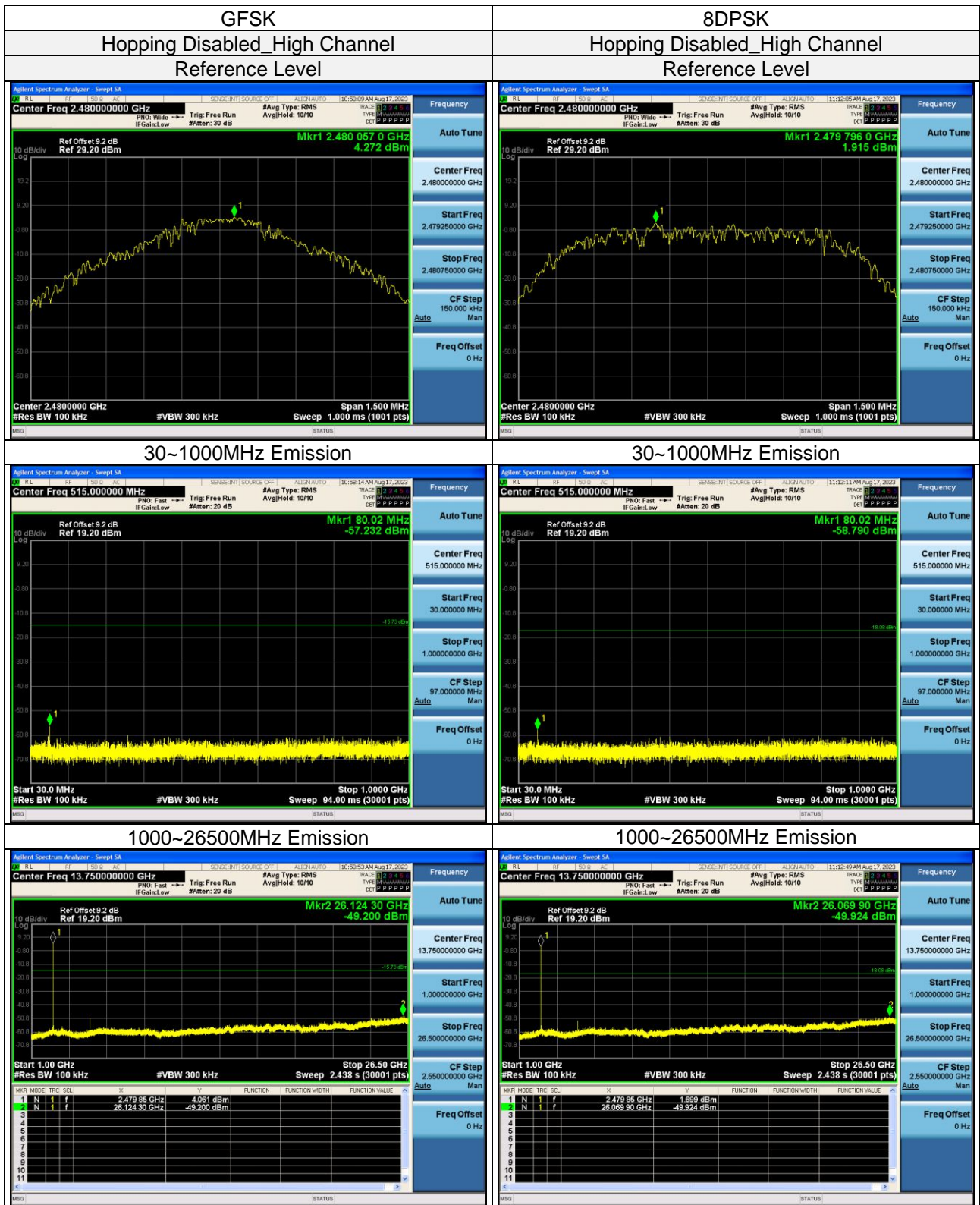

Lab: [Hwa-Hsing \(Dongguan\) Testing Co., Ltd.](#)
 Address: [No.101, Building N1, Yuyuan 2 Road, Yuyuan Industrial Park, HuangJiang Town, Dongguan City, People's Republic of China](#)

Tel: [0769-83078199](tel:0769-83078199)
 Web.: www.hwa-hsing.com
 E-Mail: customerservice.dg@hwa-hsing.com

Release
 Ver. 1.5



Lab: [Hwa-Hsing \(Dongguan\) Testing Co., Ltd.](#)
 Address: [No.101, Building N1, Yuyuan 2 Road, Yuyuan Industrial Park, Huangjiang Town, Dongguan City, People's Republic of China](#)

Tel: [0769-83078199](tel:0769-83078199)
 Web.: www.hwa-hsing.com
 E-Mail: customerservice.dg@hwa-hsing.com

Release
 Ver. 1.5

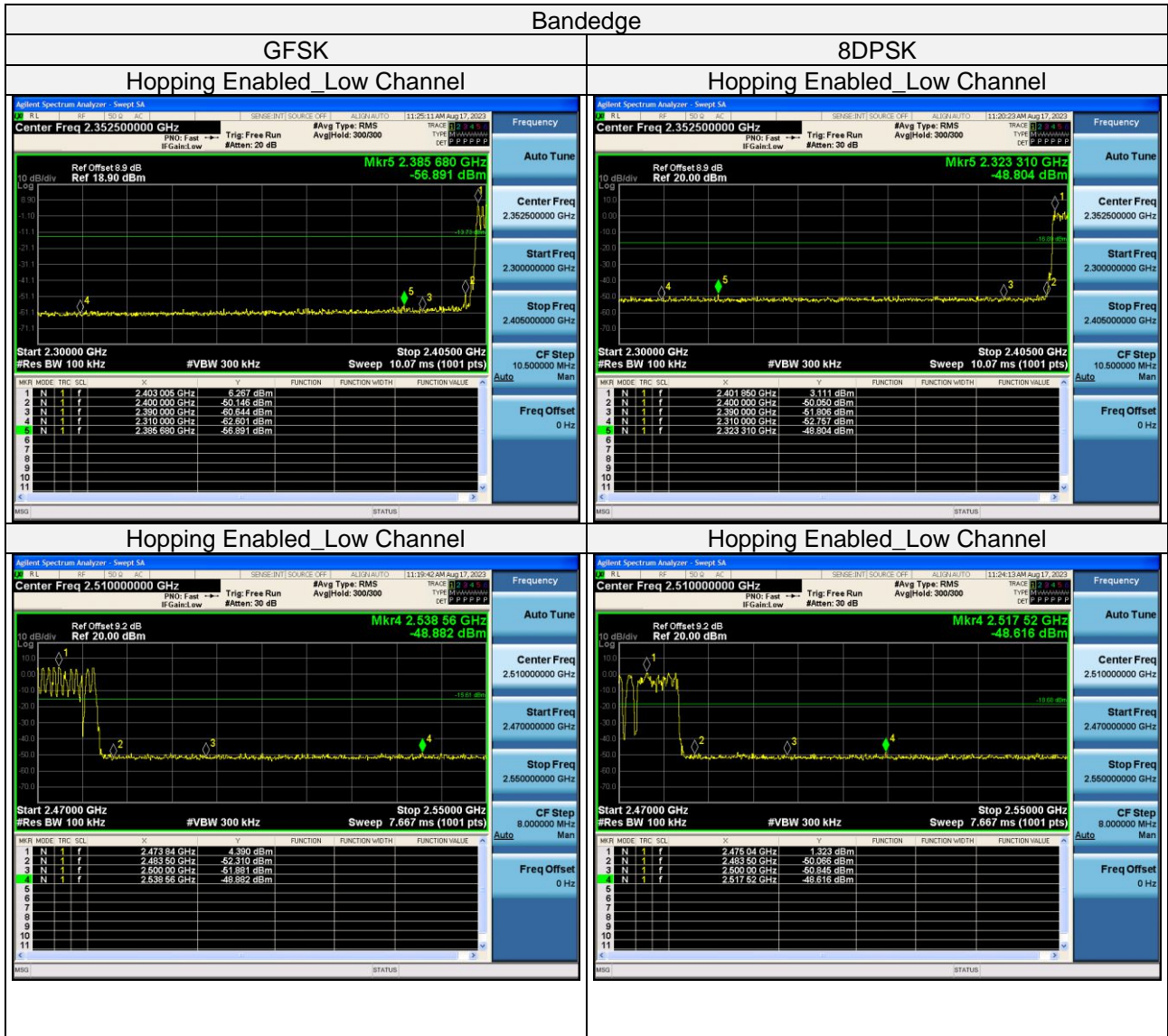



4 Pictures of Test Arrangements

Please refer to the attached file (Test Setup Photo).



5 Test Instruments

Equipment	Manufacturer	Model No.	Serial No.	Next Cal.Date
Spectrum	Keysight	N9020A	MY51240612	2024-08-06
Spectrum Analyzer	Rohde&Schwarz	FSV-40N	101783	2023-12-27
Power Meter 10Hz~18GHz	Tonscend	JS0806-2	188060126	2024-08-06
Signal generator	Keysight	E4421B	GB40051020	2024-03-15
Universal Switch Control Unit	Rohde&Schwarz	CMW500	12010002k50	2023-12-27
Test Software	Tonscend	JS0806-2	NA	NA
Humidity tester	Jingchuang	GSP-8A	CMA22B000592	2024-01-15

Note: 1. The calibration interval of the above test instruments is 12 months.
2. The test was performed in RF Chamber.



Appendix – Information on the Testing Laboratories

We, [Hwa-Hsing \(Dongguan\) Testing Co., Ltd.](#), A global provider of TESTING and CERTIFICATION services for consumer products, electronic products and wireless information technology products. Adhering to the core values “HONEST and TRUSTWORTHY, OBJECTIVE and IMPARTIALITY, RIGOROUS and AFFICIENT”, commitment to provide professional, perfect and efficient comprehensive ONE-STOP solution of TESTING and CERTIFICATION services for Manufacturers, Buyers, Traders, Brands, Retailers. Assist client to better manage risk, protect their brands, reduce costs and cut time to over 150 markets in global. Our laboratories are FCC recognized accredited test firms and accredited and approved according to ISO/IEC 17025.

If you have any comments, please feel free to contact us at the following:

Lab Address: [No.101, Building N1, Yuyuan 2 Road, Yuyuan Industrial Park, HuangJiang Town, Dongguan City, People’s Republic of China](#)

Contact Tel: [0769-83078199](tel:0769-83078199)

Email: Customerservice.dg@hwa-hsing.com

Web Site: www.hwa-hsing.com

The address and road map of all our labs can be found in our web site also.

--- END ---