



FCC Test Report

FCC ID: XN6-SB3630E6

Product: 36"Sound Bar 3.0 System
Trade Mark: VIZIO
Model Number: SB3630-E6
Serial Model: N/A
Report No.: NTEK- 2017NT02211559F

Prepared for

Zylux Acoustic Corporation
3F, 22, Lane 35, Jihu Road, Neihu Technology Park, 114 Taipei Taiwan

Prepared by

NTEK Testing Technology Co., Ltd.
1/F, Building E, Fenda Science Park, Sanwei Community,
Xixiang Street Bao'an District, Shenzhen 518126 P.R. China
Tel.: +86-755-6115 6588
Fax.: +86-755-6115 6599
Website:<http://www.ntek.org.cn>



TEST RESULT CERTIFICATION

Applicant's name : Zylux Acoustic Corporation
 Address : 3F, 22, Lane 35, Jihu Road, Neihu Technology Park, 114
 Taipei Taiwan
Manufacturer's Name : Zylux Acoustic Corporation
 Address : 3F, 22, Lane 35, Jihu Road, Neihu Technology Park, 114
 Taipei Taiwan
Factory's Name : Zhao Yang Electronic (Shenzhen) Co. , Ltd.
 Address : Building 2, De Yong Jia Industrial Park, Guang Qiao Road, Yu Lv
 Community, Gong Ming Street, Guang Ming New District,
 Shenzhen, 518132, China

Product description

Product name : 36"Sound Bar 3.0 System
 Model and/or type reference : SB3630-E6
 Standards : FCC Part15B:01 Oct.2016
 ANSI C63.4:2014

This device described above has been tested by NTEK, and the test results show that the equipment under test (EUT) is in compliance with Part 15 of FCC Rules. And it is applicable only to the tested sample identified in the report.

This report shall not be reproduced except in full, without the written approval of NTEK, this document may be altered or revised by NTEK, personnel only, and shall be noted in the revision of the document.

Date of Test :
 Date (s) of performance of tests : 21 Feb. 2017 ~04 Mar. 2017
 Date of Issue..... : 04 Mar. 2017
 Test Result..... : **Pass**

Testing Engineer : _____
 (Lake Xie)

Technical Manager : _____
 (Jason Chen)

Authorized Signatory : _____
 (Sam Chen)

Table of Contents	Page
1 . TEST SUMMARY	4
1.1 TEST FACILITY	5
1.2 MEASUREMENT UNCERTAINTY	5
2 . GENERAL INFORMATION	6
2.1 GENERAL DESCRIPTION OF EUT	6
2.2 DESCRIPTION OF TEST SETUP	8
2.3 DESCRIPTION TEST PERIPHERAL AND EUT PERIPHERAL	9
2.4 MEASUREMENT INSTRUMENTS LIST	10
3 . EMC EMISSION TEST	11
3.1 CONDUCTED EMISSION MEASUREMENT	11
3.1.1 POWER LINE CONDUCTED EMISSION	11
3.1.2 TEST PROCEDURE	12
3.1.3 TEST SETUP	12
3.1.4 EUT OPERATING CONDITIONS	12
3.1.5 TEST RESULTS	13
3.2 RADIATED EMISSION MEASUREMENT	17
3.2.1 LIMITS OF RADIATED EMISSION MEASUREMENT	17
3.2.2 TEST PROCEDURE	17
3.2.3 TEST SETUP	18
3.2.4 TEST RESULTS	19
3.2.5 TEST RESULTS(1000~25000MHz)	23
4 . EUT TEST PHOTO	25

1. TEST SUMMARY

Test procedures according to the technical standards:

EMC Emission				
Standard	Test Item	Limit	Judgment	Remark
FCC Part15B:2016 ANSI C63.4: 2014	Conducted Emission	Class B	PASS	
	Radiated Emission	Class B	PASS	

NOTE:

- (1) 'N/A' denotes test is not applicable in this Test Report
- (2) For client's request and manual description, the test will not be executed.

1.1 TEST FACILITY

NTEK Testing Technology Co., Ltd

Add. : 1/F, Building E, Fenda Science Park, Sanwei Community, Xixiang Street, Bao'an District, Shenzhen P.R. China.

FCC Registration Number:238937; IC Registration Number:9270A-1

CNAS Registration Number:L5516

1.2 MEASUREMENT UNCERTAINTY

The reported uncertainty of measurement $y \pm U$, where expanded uncertainty U is based on a standard uncertainty multiplied by a coverage factor of $k=2$, providing a level of confidence of approximately **95** %.

A. Conducted Measurement :

Test Site	Method	Measurement Frequency Range	U, (dB)	NOTE
NTEKC01	ANSI	150 KHz ~ 30MHz	3.2	

B. Radiated Measurement :

Test Site	Method	Measurement Frequency Range	U, (dB)	NOTE
NTEKA01	ANSI	30MHz ~ 1000MHz	4.7	
		1GHz ~12.4GHz	5.0	

2. GENERAL INFORMATION

2.1 GENERAL DESCRIPTION OF EUT

Equipment	36"Sound Bar 3.0 System	
Trade Mark	VIZIO	
Model Name	SB3630-E6	
Serial Model	N/A	
Remark	The SB3630-E6 have two power sources(AC Power#1 and AC Power#2) to choose, and Please see below.	
Product Description	The EUT is a 36"Sound Bar 3.0 System.	
	Connecting I/O port:	USB, DC in
	Operation Frequency:	N/A
	Modulation Type:	N/A
Power Source	AC Voltage	
Power Rating	AC 120V/60Hz , 60W	
Adapter	N/A	
Battery	N/A	
HW Version	N/A	
SW Version	N/A	

2.1.1 DESCRIPTION OF TEST MODES

To investigate the maximum EMI emission characteristics generates from EUT, the test system was pre-scanning tested base on the consideration of following EUT operation mode or test configuration mode which possible have effect on EMI emission level. Each of these EUT operation mode(s) or test configuration mode(s) mentioned above was evaluated respectively.

Pretest Mode	Description
Mode 1	AUX in
Mode 2	Optical
Mode 3	HDMI
Mode 4	USB

For Conducted Test	
Final Test Mode	Description
Mode 1	AUX in
Mode 2	Optical
Mode 3	HDMI
Mode 4	USB

For Radiated Test	
Final Test Mode	Description
Mode 1	AUX in
Mode 2	Optical
Mode 3	HDMI
Mode 4	USB

Note: Final Test Mode: Through Pre-scan, find the mode 3 is the worst case. Only the worst case mode is recorded in the report.

2.2 DESCRIPTION OF TEST SETUP

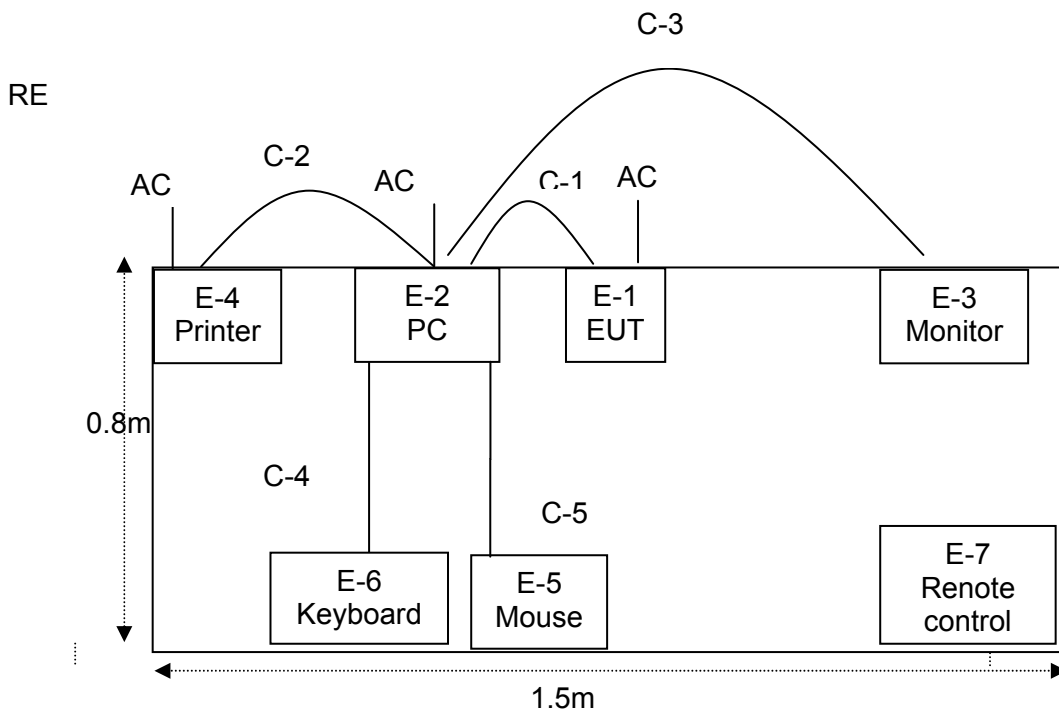
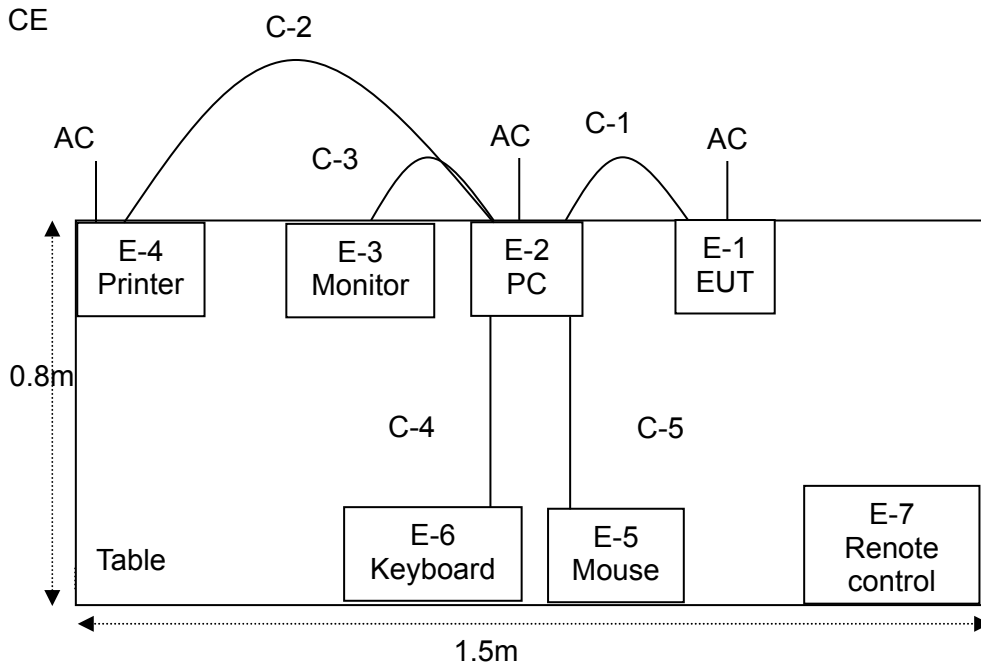

2.3 DESCRIPTION TEST PERIPHERAL AND EUT PERIPHERAL

The EUT has been tested as an independent unit together with other necessary accessories or support units. The following support units or accessories were used to form a representative test configuration during the tests.

Item	Equipment	Brand	Model/Type No.	Series No.	Note
E-1	36" Sound Bar 3.0 System	N/A	SB3630-E6	N/A	EUT
E-2	Personal computer	DELL	FT4Y23X	N/A	
E-3	Monitor	SONY	KDL-24EX520	N/A	
E-4	Printer	Canon	L11121E	N/A	
E-5	Mouse	DELL	MS111-P	N/A	
E-6	Keyboard	DELL	SK-8185	N/A	
E-7	Remote control	N/A	N/A	N/A	

Item	Cable Type	Shielded Type	Ferrite Core	Length	Note
C-1	USB Cable	NO	NO	1.5m	
C-2	USB Cable	NO	NO	1.5m	
C-3	HDMI	NO	NO	0.8m	
C-4	Keyboard Cable	NO	NO	1.2m	
C-5	Mouse Cable	NO	NO	1.2m	

Note:

- (1) The support equipment was authorized by Declaration of Confirmation.
- (2) For detachable type I/O cable should be specified the length in cm in 『Length』 column.
- (3) "YES" means "shielded" "with core"; "NO" means "unshielded" "without core".

2.4 MEASUREMENT INSTRUMENTS LIST

Radiation Test equipment

Item	Kind of Equipment	Manufacturer	Type No.	Serial No.	Last calibration	Calibrated until	Calibration period
1	Spectrum Analyzer	Agilent	E4407B	MY45108040	2016.07.06	2017.07.05	1 year
2	Test Receiver	R&S	ESPI	101318	2016.06.07	2017.06.06	1 year
3	Bilog Antenna	TESEQ	CBL6111D	31216	2016.07.06	2017.07.05	1 year
4	50Ω Coaxial Switch	Anritsu	MP59B	6200264416	2016.06.07	2017.06.06	1 year
5	Spectrum Analyzer	ADVANTEST	R3132	150900201	2016.06.07	2017.06.06	1 year
6	Horn Antenna	EM	EM-AH-10180	2011071402	2016.07.06	2017.07.05	1 year
7	Horn Ant	Schwarzbeck	BBHA 9170	9170-181	2016.07.06	2017.07.05	1 year
8	Amplifier	EM	EM-30180	060538	2016.07.06	2017.07.05	1 year
9	Loop Antenna	ARA	PLA-1030/B	1029	2016.06.08	2017.06.07	1 year
10	Power Meter	R&S	NRVS	100696	2016.07.06	2017.07.05	1 year
11	Power Sensor	R&S	URV5-Z4	0395.1619.05	2016.07.06	2017.07.05	1 year
12	Test Cable	N/A	R-01	N/A	2016.07.06	2017.07.05	1 year
13	Test Cable	N/A	R-02	N/A	2016.07.06	2017.07.05	1 year

Conduction Test equipment

Item	Kind of Equipment	Manufacturer	Type No.	Serial No.	Last calibration	Calibrated until	Calibration period
1	Test Receiver	R&S	ESCI	101160	2016.06.06	2017.06.05	1 year
2	LISN	R&S	ENV216	101313	2016.08.24	2017.08.23	1 year
3	LISN	EMCO	3816/2	00042990	2016.08.24	2017.08.23	1 year
4	50Ω Coaxial Switch	Anritsu	MP59B	6200264417	2016.06.07	2017.06.06	1 year
5	Passive Voltage Probe	R&S	ESH2-Z3	100196	2016.06.07	2017.06.06	1 year
6	Absorbing clamp	R&S	MOS-21	100423	2016.06.08	2017.06.07	1 year
7	Test Cable	N/A	C01	N/A	2016.06.08	2017.06.07	1 year
8	Test Cable	N/A	C02	N/A	2016.06.08	2017.06.07	1 year
9	Test Cable	N/A	C03	N/A	2016.06.08	2017.06.07	1 year

3. EMC EMISSION TEST

3.1 CONDUCTED EMISSION MEASUREMENT

3.1.1 POWER LINE CONDUCTED EMISSION (Frequency Range 150KHz-30MHz)

FREQUENCY (MHz)	Class A (dBuV)		Class B (dBuV)	
	Quasi-peak	Average	Quasi-peak	Average
0.15 -0.5	79.00	66.00	66 - 56 *	56 - 46 *
0.50 -5.0	73.00	60.00	56.00	46.00
5.0 -30.0	73.00	60.00	60.00	50.00

Note:

- (1) The tighter limit applies at the band edges.
- (2) The limit of " * " marked band means the limitation decreases linearly with the logarithm of the frequency in the range.

The following table is the setting of the receiver

Receiver Parameters	Setting
Attenuation	10 dB
Start Frequency	0.15 MHz
Stop Frequency	30 MHz
IF Bandwidth	9 kHz

3.1.2 TEST PROCEDURE

- a. The EUT was placed 0.8 meters from the horizontal ground plane with EUT being connected to the power mains through a line impedance stabilization network (LISN). All other support equipments powered from additional LISN(s). The LISN provide 50 Ohm/ 50uH of coupling impedance for the measuring instrument.
- b. Interconnecting cables that hang closer than 40 cm to the ground plane shall be folded back and forth in the center forming a bundle 30 to 40 cm long.
- c. I/O cables that are not connected to a peripheral shall be bundled in the center. The end of the cable may be terminated, if required, using the correct terminating impedance. The overall length shall not exceed 1 m.
- d. LISN at least 80 cm from nearest part of EUT chassis.
- e. For the actual test configuration, please refer to the related Item –EUT Test Photos.

3.1.3 TEST SETUP

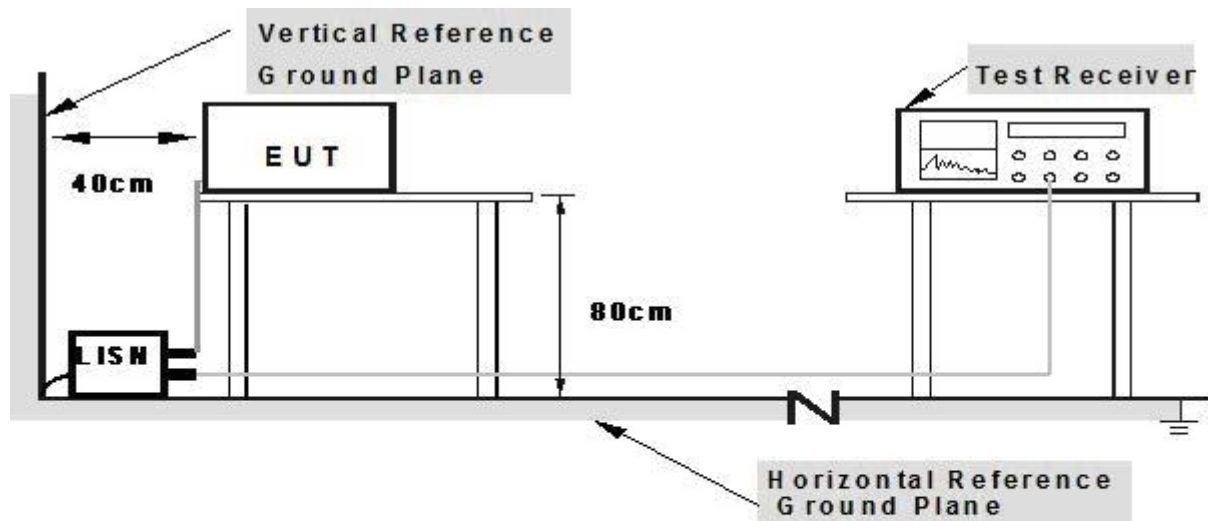

Note: 1. Support units were connected to second LISN.

2. Both of LISNs (AMN) are 80 cm from EUT and at least 80 cm from other units and other metal planes

3.1.4 EUT OPERATING CONDITIONS

The EUT tested system was configured as the statements of 2.3 Unless otherwise a special operating condition is specified in the follows during the testing.

3.1.5 TEST RESULTS

EUT:	36"Sound Bar 3.0 System	Model Name. :	SB3630-E6
Temperature:	26 °C	Relative Humidity:	54%
Pressure:	1010hPa	Test Date:	2017-2-21
Test Mode:	Mode 3	Phase :	L
Test Voltage:	AC 120V/60Hz(AC Power#1)		

Frequency (MHz)	Reading Level (dBμV)	Correct Factor (dB)	Measure-ment (dBμV)	Limits (dBμV)	Margin (dB)	Remark
0.15	36.83	9.68	46.51	65.99	-19.48	QP
0.15	18.22	9.68	27.9	55.99	-28.09	AVG
0.162	35.68	9.68	45.36	65.36	-20	QP
0.162	17.21	9.68	26.89	55.36	-28.47	AVG
0.1779	33.99	9.68	43.67	64.58	-20.91	QP
0.1779	16.96	9.68	26.64	54.58	-27.94	AVG
0.4779	29.91	9.68	39.59	56.38	-16.79	QP
0.4779	20.82	9.68	30.5	46.38	-15.88	AVG
20.858	31.64	10.01	41.65	60	-18.35	QP
20.858	21.17	10.01	31.18	50	-18.82	AVG
28.57	34.55	10.04	44.59	60	-15.41	QP
28.57	12.45	10.04	22.49	50	-27.51	AVG

Remark:

1. All readings are Quasi-Peak and Average values.
2. Factor = Insertion Loss + Cable Loss.

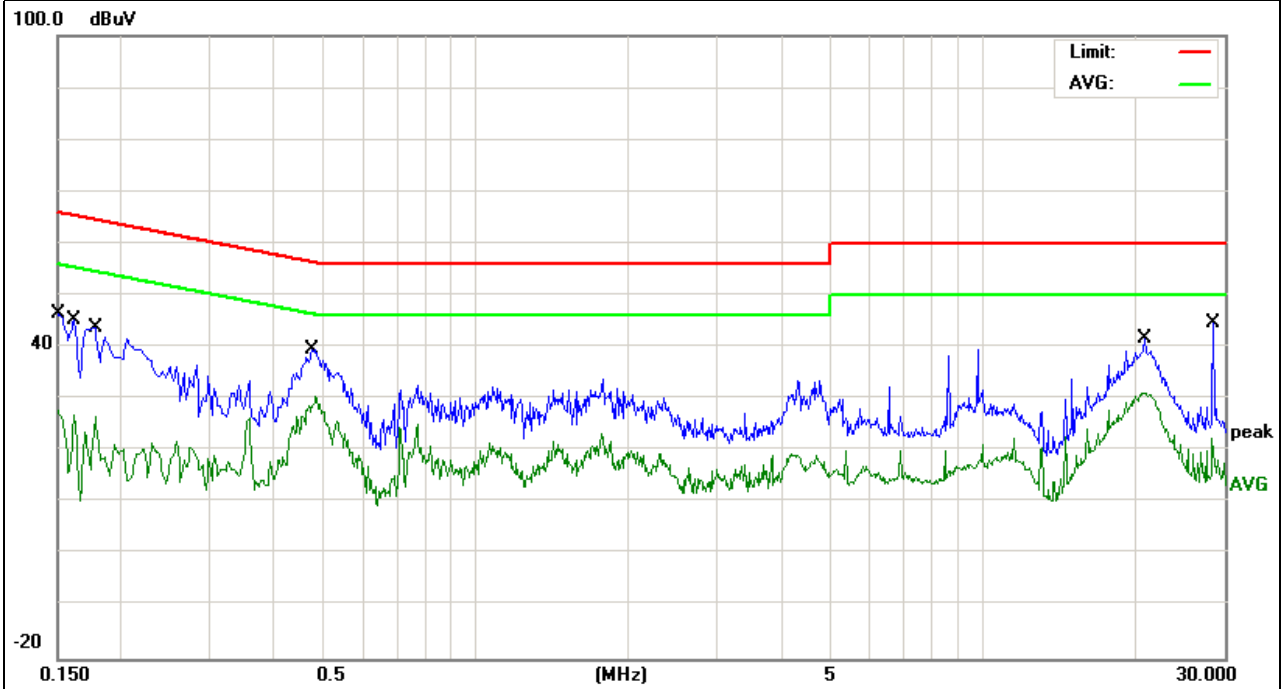

EUT:	36"Sound Bar 3.0 System	Model Name. :	SB3630-E6
Temperature:	26 °C	Relative Humidity:	54%
Pressure:	1010hPa	Test Date:	2017-2-21
Test Mode:	Mode 3	Phase :	N
Test Voltage:	AC 120V/60Hz(AC Power#1)		

Frequency (MHz)	Reading Level (dBμV)	Correct Factor (dB)	Measure-ment (dBμV)	Limits (dBμV)	Margin (dB)	Remark
0.158	38.44	9.68	48.12	65.56	-17.44	QP
0.158	14.34	9.68	24.02	55.56	-31.54	AVG
0.4858	30.08	9.68	39.76	56.24	-16.48	QP
0.4858	21.08	9.68	30.76	46.24	-15.48	AVG
10.4938	31.52	9.86	41.38	60	-18.62	QP
10.4938	12.78	9.86	22.64	50	-27.36	AVG
18.6177	32.1	9.99	42.09	60	-17.91	QP
18.6177	18.14	9.99	28.13	50	-21.87	AVG
22.4618	32.83	10.01	42.84	60	-17.16	QP
22.4618	20.96	10.01	30.97	50	-19.03	AVG
29.9058	32.51	10.06	42.57	60	-17.43	QP
29.9058	11.76	10.06	21.82	50	-28.18	AVG

Remark:

1. All readings are Quasi-Peak and Average values.
2. Factor = Insertion Loss + Cable Loss.

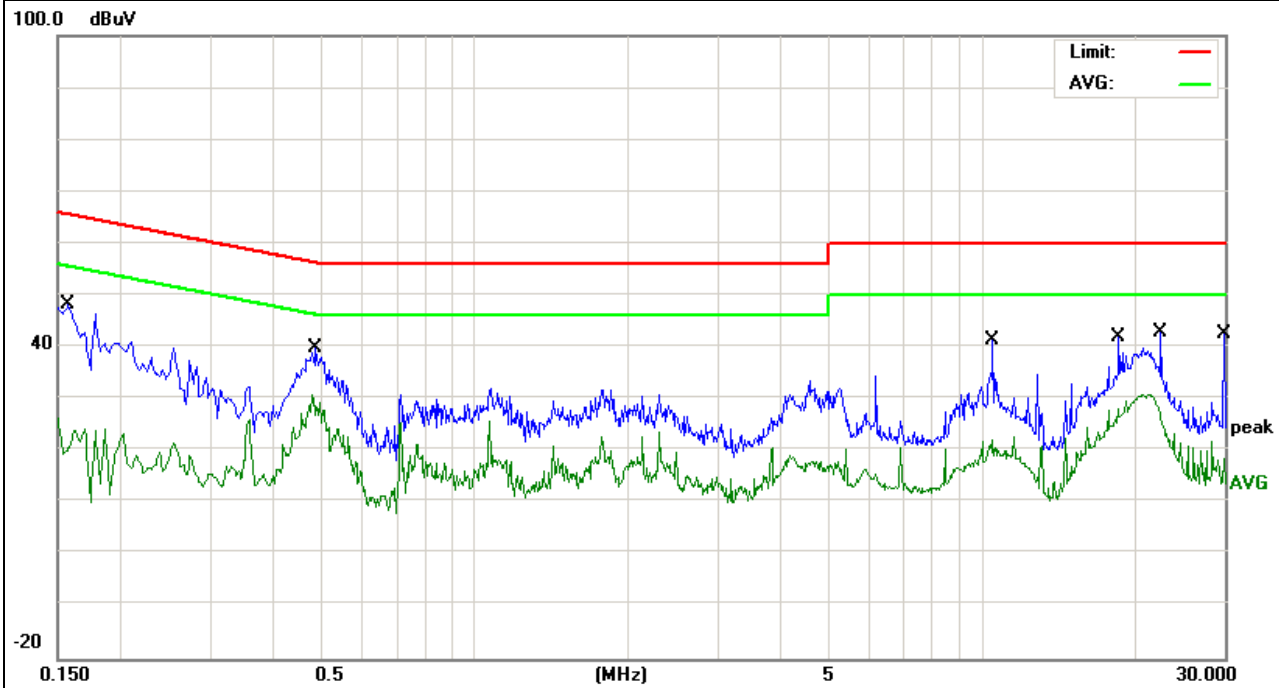

EUT:	36"Sound Bar 3.0 System	Model Name. :	SB3630-E6
Temperature:	26 °C	Relative Humidity:	54%
Pressure:	1010hPa	Test Date:	2017-2-21
Test Mode:	Mode 3	Phase :	L
Test Voltage:	AC 120V/60Hz(AC Power#2)		

Frequency (MHz)	Reading Level (dBμV)	Correct Factor (dB)	Measure-ment (dBμV)	Limits (dBμV)	Margin (dB)	Remark
0.15	43.56	9.58	53.14	65.99	-12.85	QP
0.15	20.02	9.58	29.6	55.99	-26.39	AVG
0.194	36.7	9.58	46.28	63.86	-17.58	QP
0.194	16.49	9.58	26.07	53.86	-27.79	AVG
0.23	33.81	9.58	43.39	62.45	-19.06	QP
0.23	13.44	9.58	23.02	52.45	-29.43	AVG
0.4259	31.5	9.58	41.08	57.33	-16.25	QP
0.4259	22.6	9.58	32.18	47.33	-15.15	AVG
4.4537	24.55	9.67	34.22	56	-21.78	QP
4.4537	10.83	9.67	20.5	46	-25.5	AVG
4.9058	24.59	9.69	34.28	56	-21.72	QP
4.9058	9.48	9.69	19.17	46	-26.83	AVG

Remark:

1. All readings are Quasi-Peak and Average values.
2. Factor = Insertion Loss + Cable Loss.

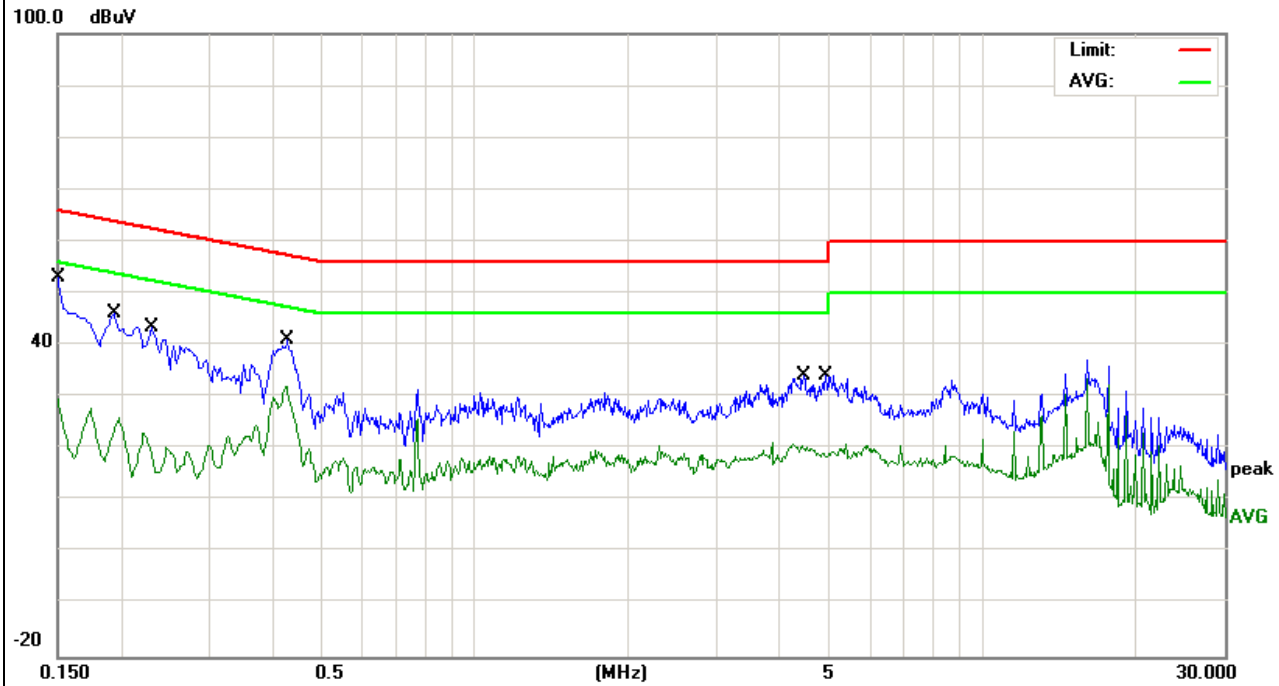

EUT:	36"Sound Bar 3.0 System	Model Name. :	SB3630-E6
Temperature:	26 °C	Relative Humidity:	54%
Pressure:	1010hPa	Test Date:	2017-2-21
Test Mode:	Mode 3	Phase :	N
Test Voltage:	AC 120V/60Hz(AC Power#2)		

Frequency (MHz)	Reading Level (dBμV)	Correct Factor (dB)	Measure-ment (dBμV)	Limits (dBμV)	Margin (dB)	Remark
0.15	40.23	9.58	49.81	65.99	-16.18	QP
0.15	19.83	9.58	29.41	55.99	-26.58	AVG
0.166	38.26	9.58	47.84	65.15	-17.31	QP
0.166	18.8	9.58	28.38	55.15	-26.77	AVG
0.2099	34.37	9.58	43.95	63.21	-19.26	QP
0.2099	14.44	9.58	24.02	53.21	-29.19	AVG
0.33	28.13	9.57	37.7	59.45	-21.75	QP
0.33	15.33	9.57	24.9	49.45	-24.55	AVG
0.4259	30.75	9.58	40.33	57.33	-17	QP
0.4259	22.28	9.58	31.86	47.33	-15.47	AVG
4.8658	28.63	9.69	38.32	56	-17.68	QP
4.8658	16.01	9.69	25.7	46	-20.3	AVG

Remark:

1. All readings are Quasi-Peak and Average values.
2. Factor = Insertion Loss + Cable Loss.

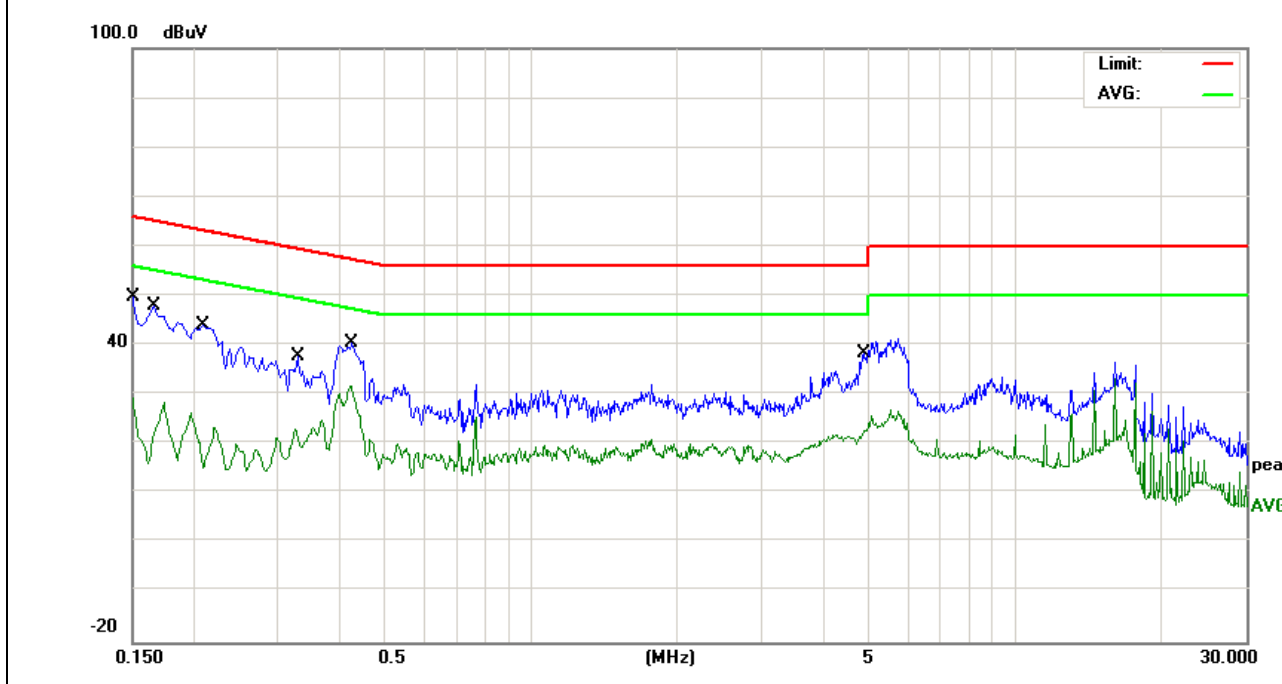

3.2 RADIATED EMISSION MEASUREMENT

3.2.1 LIMITS OF RADIATED EMISSION MEASUREMENT

FREQUENCY (MHz)	Class A (at 10m)	Class B (at 3m)
	dBuV/m	dBuV/m
30 ~ 88	39.0	40.0
88 ~ 216	43.5	43.5
216 ~ 960	46.5	46.0
Above 960	49.5	54.0

Notes:

- (1) The limit for radiated test was performed according to as following:
FCC PART 15B /ICES-003.
- (2) The tighter limit applies at the band edges.
- (3) Emission level (dBuV/m)=20log Emission level (uV/m).

3.2.2 TEST PROCEDURE

Test Arrangement for Radiated Emissions up to 1 GHz

- a. The EUT was placed on the top of a rotating table 0.8 meters above the ground at an accredited test facility. The table was rotated 360 degrees to determine the position of the highest radiation.
- b. The EUT was set 3 meters away from the interference-receiving antenna, which was mounted on the top of a variable-height antenna tower.
- c. The antenna is a broadband antenna, and its height is varied from one meter to four meters above the ground to determine the maximum value of the field strength. Both horizontal and vertical polarizations of the antenna are set to make the measurement.
- d. For each suspected emission, the EUT was arranged to its worst case and then the antenna was tuned to heights from 1 meter to 4 meters and the rotatable table was turned from 0 degrees to 360 degrees to find the maximum reading.

Note: The resolution bandwidth and video bandwidth of test receiver/spectrum analyzer is 120kHz for quasi-peak detection (QP) at frequency below 1GHz.

Test Arrangement for Radiated Emissions above 1 GHz.

- a. The EUT was placed on the top of a rotating table 0.8 meters above the ground at an accredited chamber room. The table was rotated 360 degrees to determine the position of the highest radiation.
- b. The EUT was set 3 meters away from the interference-receiving antenna, which was mounted on the top of a variable-height antenna tower.
- c. The height of antenna can be varied from one meter to four meters, the height of adjustment depends on the EUT height and the antenna 3dB beamwidth both, to detect the maximum value of the field strength.Both horizontal and vertical polarizations of the antenna are set to make the measurement.
- d. For each suspected emission, the EUT was arranged to its worst case and then the antenna was tuned to heights and the rotatable table was turned from 0 degrees to 360 degrees to find the maximum reading.

Note: For the hand-held device, the EUT should be measured for all 3 axes and only the worst case is recorded in the report
 During the radiated emission test, the Spectrum Analyzer was set with the following configurations:

Frequency Band (MHz)	Function	Resolution bandwidth	Video Bandwidth
30 to 1000	QP	120 kHz	300 kHz
Above 1000	Peak	1 MHz	1 MHz
	PK detector is forAV	1 MHz	10 Hz

3.2.3 TEST SETUP

For Radiated Emission 30~1000MHz

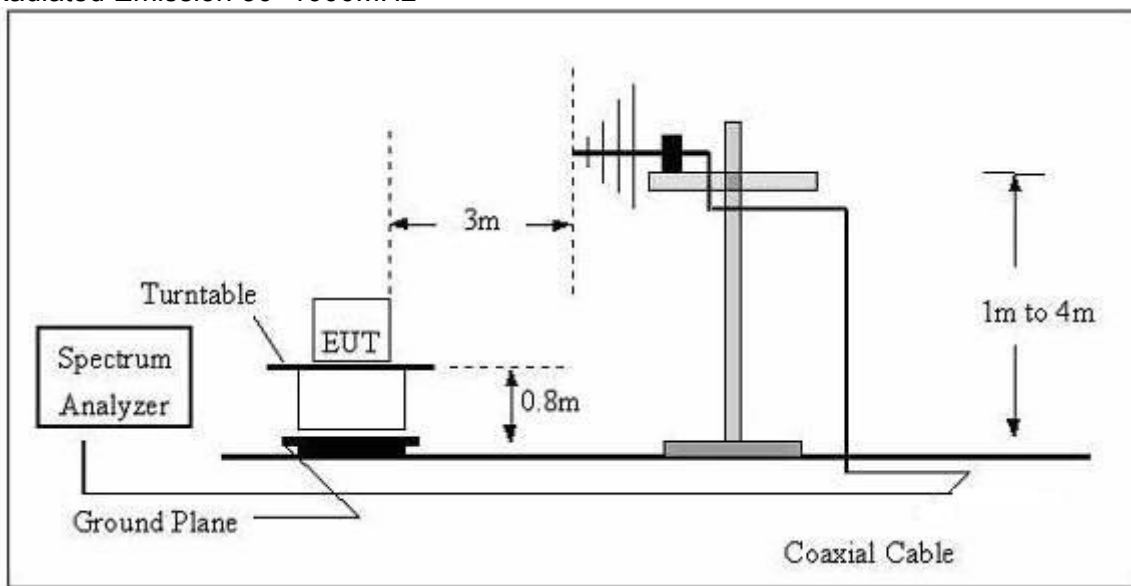

(B) Radiated Emission Test Set-Up Frequency Above 1GHz

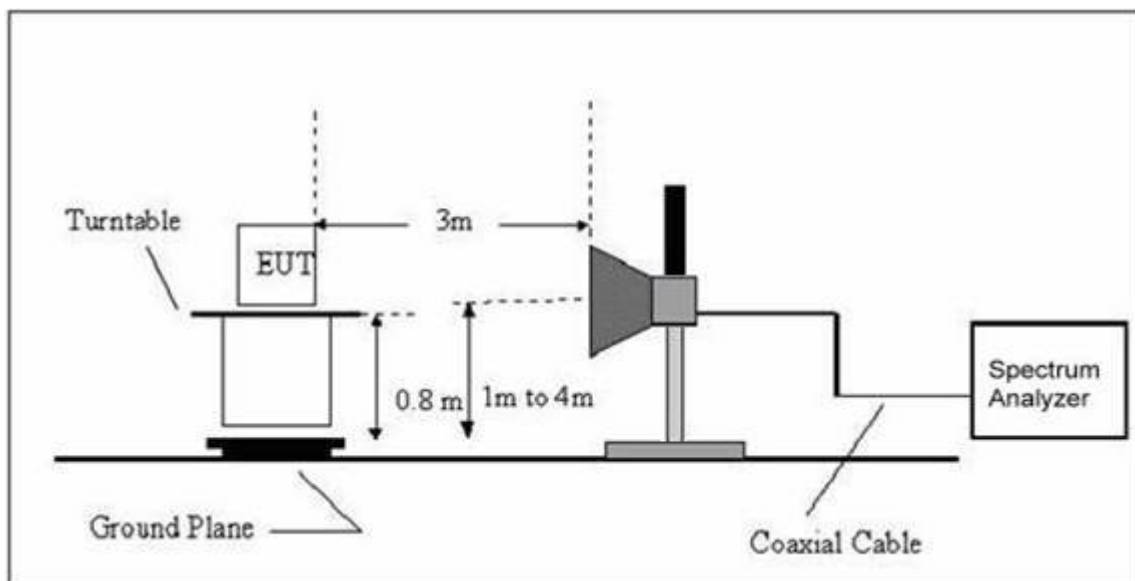

3.2.4 TEST RESULTS

TEST RESULTS (30~1000 MHz)

EUT:	36"Sound Bar 3.0 System	Model Name:	SB3630-E6
Temperature:	24 °C	Relative Humidity:	54%
Pressure:	1010 hPa	Test Date :	2017-2-21
Test Mode :	Mode 3	Polarization :	Horizontal
Test Power :	AC 120V/60Hz(AC Power#1)		

Polar (H/V)	Frequency	Meter Reading	Factor	Emission Level	Limits	Margin	Remark
	(MHz)	(dBuV)	(dB)	(dBuV/m)	(dBuV/m)	(dB)	
H	82.9385	23.98	9.15	33.13	40	-6.87	QP
H	85.8983	26.87	9.66	36.53	40	-3.47	QP
H	92.1388	25.06	11	36.06	43.5	-7.44	QP
H	110.5687	24.85	12.66	37.51	43.5	-5.99	QP
H	135.0319	22.17	13.13	35.3	43.5	-8.2	QP
H	243.3771	24.55	13.9	38.45	46	-7.55	QP

Remark:

Factor = Antenna Factor + Cable Loss - Amplifier.

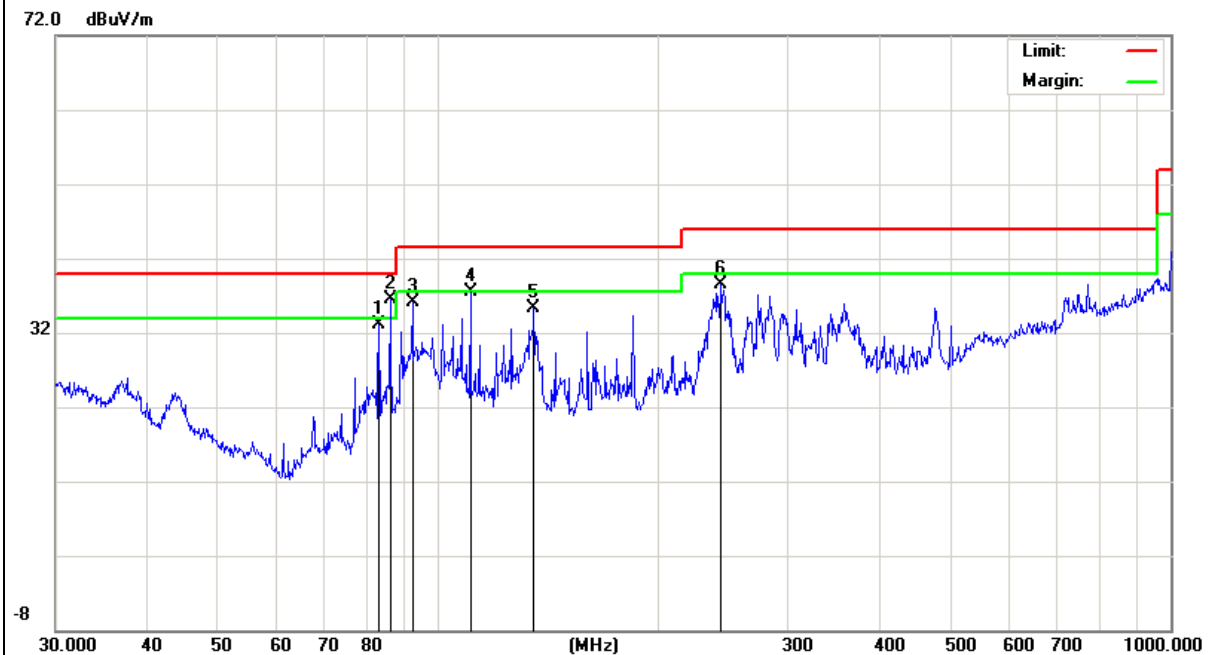

EUT:	36"Sound Bar 3.0 System	Model Name :	SB3630-E6
Temperature:	24 °C	Relative Humidity:	54%
Pressure:	1010 hPa	Test Date :	2016-12-12
Test Mode :	Mode 3	Polarization :	Vertical
Test Power :	AC 120V/60Hz(AC Power#1)		

Polar (H/V)	Frequency	Meter Reading	Factor	Emission Level	Limits	Margin	Remark
	(MHz)	(dBuV)	(dB)	(dBuV/m)	(dBuV/m)	(dB)	
V	30.9618	12.27	19.37	31.64	40	-8.36	QP
V	36.7661	14.84	16.45	31.29	40	-8.71	QP
V	43.6584	17.48	12.19	29.67	40	-10.33	QP
V	85.8983	23.6	9.66	33.26	40	-6.74	QP
V	159.7844	23.33	12.19	35.52	43.5	-7.98	QP
V	771.4486	13.88	27.83	41.71	46	-4.29	QP

Remark:

Factor = Antenna Factor + Cable Loss - Amplifier.

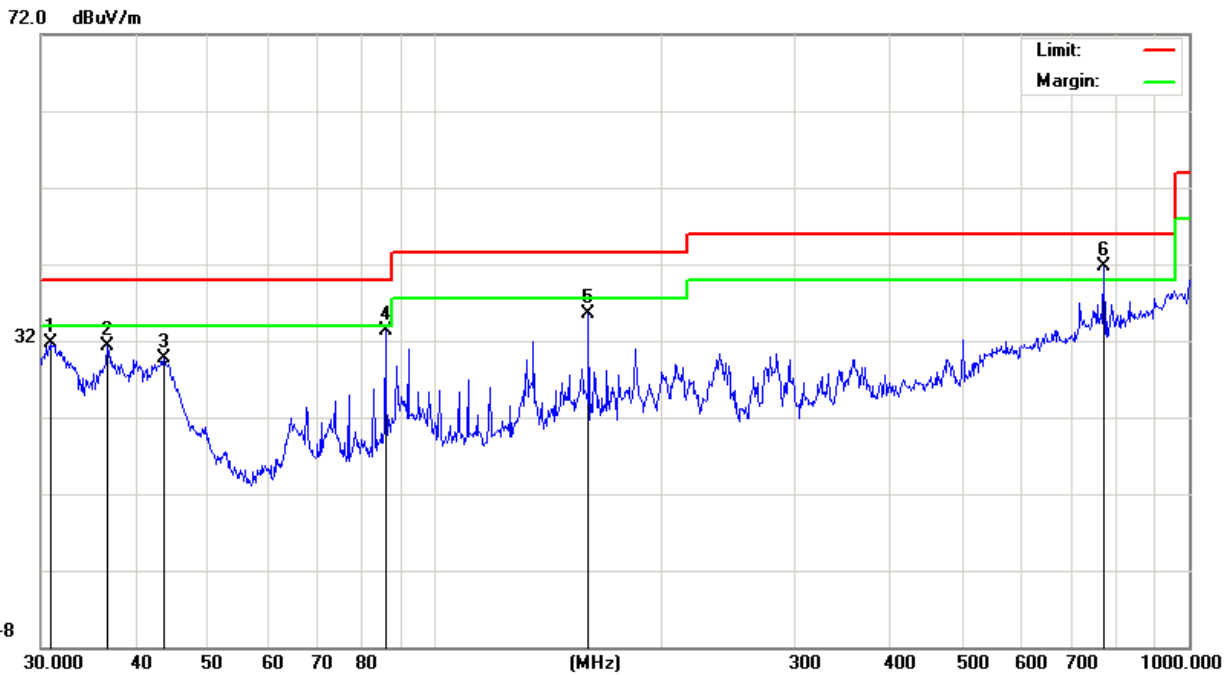

EUT:	36"Sound Bar 3.0 System	Model Name:	SB3630-E6
Temperature:	24 °C	Relative Humidity:	54%
Pressure:	1010 hPa	Test Date :	2017-2-21
Test Mode :	Mode 3	Polarization :	Horizontal
Test Power :	AC 120V/60Hz(AC Power#2)		

Polar (H/V)	Frequency	Meter Reading	Factor	Emission Level	Limits	Margin	Remark
	(MHz)	(dBuV)	(dB)	(dBuV/m)	(dBuV/m)	(dB)	
H	85.8983	26.4	9.66	36.06	40	-3.94	QP
H	92.1388	25.42	11	36.42	43.5	-7.08	QP
H	110.5687	22.02	12.66	34.68	43.5	-8.82	QP
H	188.4123	25.69	10.66	36.35	43.5	-7.15	QP
H	275.1569	24.46	15.61	40.07	46	-5.93	QP
H	771.4486	12.29	27.83	40.12	46	-5.88	QP

Remark:
Factor = Antenna Factor + Cable Loss - Amplifier.

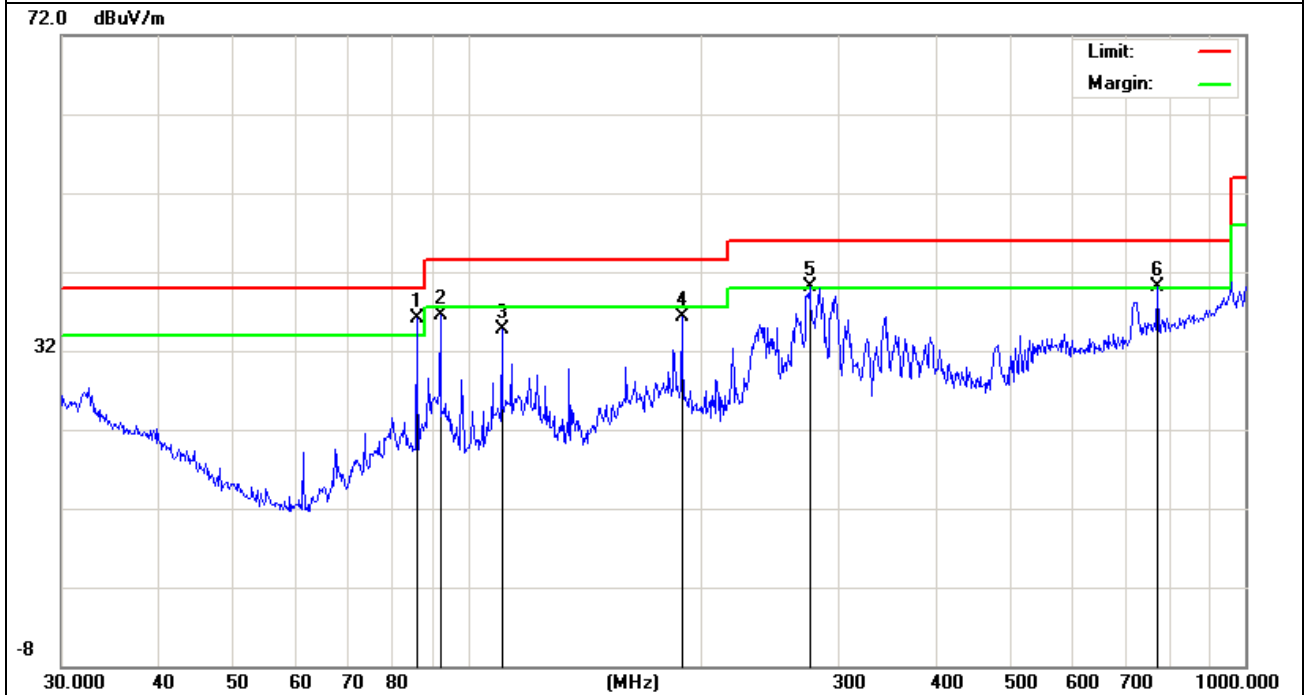

EUT:	36"Sound Bar 3.0 System	Model Name :	SB3630-E6
Temperature:	24 °C	Relative Humidity:	54%
Pressure:	1010 hPa	Test Date :	2016-12-12
Test Mode :	Mode 3	Polarization :	Vertical
Test Power :	AC 120V/60Hz(AC Power#2)		

Polar (H/V)	Frequency	Meter Reading	Factor	Emission Level	Limits	Margin	Remark
	(MHz)	(dBuV)	(dB)	(dBuV/m)	(dBuV/m)	(dB)	
V	30.7454	15.3	19.49	34.79	40	-5.21	QP
V	36.7661	13.12	16.45	29.57	40	-10.43	QP
V	85.8983	21.36	9.66	31.02	40	-8.98	QP
V	275.1569	19.3	15.61	34.91	46	-11.09	QP
V	771.4486	14.81	27.83	42.64	46	-3.36	QP
V	938.8324	6.96	30.97	37.93	46	-8.07	QP

Remark:

Factor = Antenna Factor + Cable Loss - Amplifier.

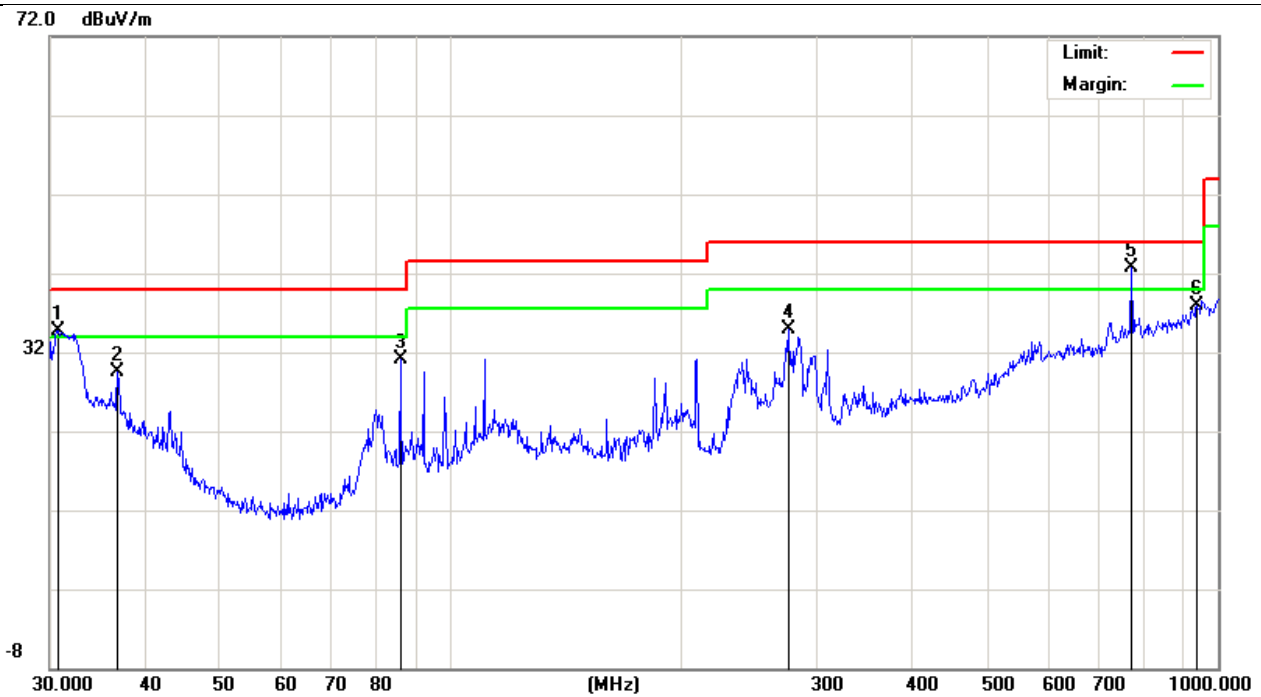

3.2.5 TEST RESULTS(1000~25000MHz)

EUT:	36"Sound Bar 3.0 System	Model Name :	SB3630-E6
Temperature:	24 °C	Relative Humidity:	54%
Pressure:	1010 hPa	Test Date :	2017-2-21
Test Mode :	Mode 3		
Test Power :	AC 120V/60Hz(AC Power#1)		

All the modulation modes have been tested, and the worst result was report as below:

Polar (H/V)	Frequency	Reading	Correct	Result	Limit	Over Limit	Remark
	(MHz)	(dBuV/m)	dB/m	(dBuV/m)	(dBuV/m)	(dB)	
V	1559.5	64.79	-13	52.29	74	-21.71	Pk
V	1559.5	52.9	-13	40.4	54	-13.6	AV
V	2077.2	59.67	-10	49.49	74	-24.51	Pk
V	2077.2	47.78	-10	37.6	54	-16.4	AV
V	3114.2	57.73	-8.1	49.6	74	-24.4	Pk
V	3114.2	46.33	-8.1	38.2	54	-15.8	AV
H	1559.5	67.23	-13	54.73	74	-19.27	Pk
H	1559.5	55.2	-13	42.7	54	-11.3	AV
H	1872.2	59.96	-11	49.05	74	-24.95	Pk
H	1872.2	48.94	-11	38.03	54	-15.97	AV
H	3119.8	56.5	-8.1	48.39	74	-25.61	Pk
H	3119.8	45.51	-8.1	37.4	54	-16.6	AV

Remark:

Emission Level = Read Level+Antenna Factor + Cable Loss - Amplifier.

Margin= Emission Level-Limits

Note:

1. Measuring frequencies from 1 GHz to 13GHz.

2. Radiated emissions measured in frequency above 1000MHz were made with an instrument using

Peak detector mode of the emission shown in Actual FS column.

3. The frequency that above 3GHz is mainly from the environment noise

EUT:	36"Sound Bar 3.0 System	Model Name :	SB3630-E6
Temperature:	24 °C	Relative Humidity:	54%
Pressure:	1010 hPa	Test Date :	2017-2-21
Test Mode :	Mode 3		
Test Power :	AC 120V/60Hz(AC Power#2)		

All the modulation modes have been tested, and the worst result was report as below:

Polar (H/V)	Frequency	Reading	Correct	Result	Limit	Over Limit	Remark
	(MHz)	(dBuV/m)	dB/m	(dBuV/m)	(dBuV/m)	(dB)	
V	1559.5	65.79	-13	53.29	74	-20.71	Pk
V	1559.5	54.1	-13	41.6	54	-12.4	AV
V	2077.2	60.67	-10	50.49	74	-23.51	Pk
V	2077.2	49.98	-10	39.8	54	-14.2	AV
V	3114.2	58.73	-8.1	50.6	74	-23.4	Pk
V	3114.2	48.33	-8.1	40.2	54	-13.8	AV
H	1559.5	68.23	-13	55.73	74	-18.27	Pk
H	1559.5	55.3	-13	42.8	54	-11.2	AV
H	1872.2	59.96	-11	49.05	74	-24.95	Pk
H	1872.2	49.31	-11	38.4	54	-15.6	AV
H	3119.8	57.5	-8.1	49.39	74	-24.61	Pk
H	3119.8	46.01	-8.1	37.9	54	-16.1	AV

Remark:

Emission Level = Read Level+Antenna Factor + Cable Loss - Amplifier.

Margin= Emission Level-Limits

Note:

1. Measuring frequencies from 1 GHz to 13GHz.
2. Radiated emissions measured in frequency above 1000MHz were made with an instrument using Peak detector mode of the emission shown in Actual FS column.
3. The frequency that above 3GHz is mainly from the environment noise

4. EUT TEST PHOTO

Radiated Measurement Photos

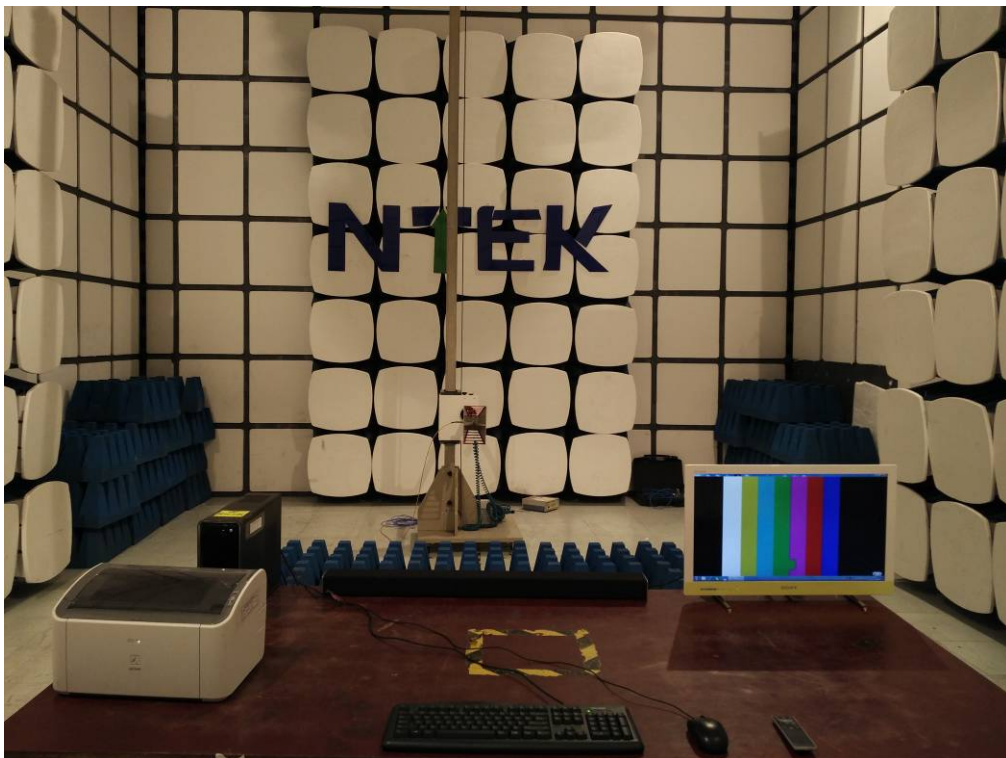

Conducted Measurement Photos

