



FCC RADIO TEST REPORT

FCC ID: XN6-S3821W

Product : 38" sound bar 2.1 system with wireless subwoofer

Trade Name : VIZIO

Model Name : S3821w-C0

Serial Model : S3821w-xxx("x" is "A-Z" or "0-9" or "Blank")

Report No. : NTEK-2013NT0411369F1

Prepared for

Zylux Acoustic Corporation

3F, 22, Lane 35, Jihu Road, Neihu Technology Park, Taipei 11492, Taiwan

Prepared by

Shenzhen NTEK Testing Technology Co., Ltd.

1/F, Building E, Fenda Science Park, Sanwei Community, Xixiang Street
Bao'an District, Shenzhen P.R. China

Tel.: +86-0755-61156588 Fax.: +86-0755-61156599

Website: www.ntek.org.cn

TEST RESULT CERTIFICATION

Applicant's name : Zylux Acoustic Corporation
Address : 3F, 22, Lane 35, Jihu Road, Neihu Technology Park, Taipei
11492, Taiwan

Manufacturer's Name : ZHAO YANG ELEC. (SHENZHEN) CO., LTD.
Address : Section A, 4th Floor, Building 1 & Building 2, Deyongjia
Industrial Park, Guangqiao Road, Yulv Community, Gongming
Street, Guangming New District, Shenzhen, China

Product description

Product name : 38" sound bar 2.1 system with wireless subwoofer

Model and/or type reference : S3821w-C0

Serial Model : S3821w-xxx("x" is "A-Z" or "0-9" or "Blank")

Standards : FCC Part15.247

Test procedure ANSI C63.4-2003

This device described above has been tested by NTEK, and the test results show that the equipment under test (EUT) is in compliance with the FCC requirements. And it is applicable only to the tested sample identified in the report.

This report shall not be reproduced except in full, without the written approval of NTEK, this document may be altered or revised by NTEK, personal only, and shall be noted in the revision of the document.

Date of Test :

Date (s) of performance of tests : 11 Apr. 2013 ~18 Apr. 2013

Date of Issue : 18 Apr. 2013

Test Result : **Pass**

Testing Engineer : Apple Huang
(Apple Huang)

Technical Manager : Tom Zhang
(Tom Zhang)

Authorized Signatory : Bovey Yang
(Bovey Yang)

Table of Contents	Page
1 . SUMMARY OF TEST RESULTS	5
1.1 TEST FACILITY	6
1.2 MEASUREMENT UNCERTAINTY	6
2 . GENERAL INFORMATION	7
2.1 GENERAL DESCRIPTION OF EUT	7
2.2 DESCRIPTION OF TEST MODES	9
2.3 TABLE OF PARAMETERS OF TEXT SOFTWARE SETTING	9
2.4 BLOCK DIGRAM SHOWING THE CONFIGURATION OF SYSTEM TESTED	10
2.5 DESCRIPTION OF SUPPORT UNITS(CONDUCTED MODE)	11
2.6 EQUIPMENTS LIST FOR ALL TEST ITEMS	12
3 . EMC EMISSION TEST	13
3.1 CONDUCTED EMISSION MEASUREMENT	13
3.1.1 POWER LINE CONDUCTED EMISSION LIMITS	13
3.1.2 TEST PROCEDURE	14
3.1.3 DEVIATION FROM TEST STANDARD	14
3.1.4 TEST SETUP	14
3.1.5 EUT OPERATING CONDITIONS	14
3.1.6 TEST RESULTS	15
3.2 RADIATED EMISSION MEASUREMENT	17
3.2.1 RADIATED EMISSION LIMITS	17
3.2.2 TEST PROCEDURE	18
3.2.3 DEVIATION FROM TEST STANDARD	18
3.2.4 TEST SETUP	19
3.2.5 EUT OPERATING CONDITIONS	20
3.2.6 TEST RESULTS (BELOW 30 MHZ)	21
3.2.7 TEST RESULTS (BETWEEN 30M – 1000 MHZ)	22
3.2.8 TEST RESULTS (ABOVE 1000 MHZ)	24
3.2.9 TEST RESULTS (RESTRICTED BANDS REQUIREMENTS)	42
4 . NUMBER OF HOPPING CHANNEL	54
4.1 APPLIED PROCEDURES / LIMIT	54
4.1.1 TEST PROCEDURE	54
4.1.2 DEVIATION FROM STANDARD	54
4.1.3 TEST SETUP	54
4.1.4 EUT OPERATION CONDITIONS	54
4.1.5 TEST RESULTS	55
5 . AVERAGE TIME OF OCCUPANCY	56
5.1 APPLIED PROCEDURES / LIMIT	56

Table of Contents	Page
5.1.1 TEST PROCEDURE	56
5.1.2 DEVIATION FROM STANDARD	56
5.1.3 TEST SETUP	57
5.1.4 EUT OPERATION CONDITIONS	57
5.1.5 TEST RESULTS	58
6 . HOPPING CHANNEL SEPARATION MEASUREMENT	60
6.1 APPLIED PROCEDURES / LIMIT	60
6.1.1 TEST PROCEDURE	60
6.1.2 DEVIATION FROM STANDARD	60
6.1.3 TEST SETUP	60
6.1.4 EUT OPERATION CONDITIONS	60
6.1.5 TEST RESULTS	61
7 . BANDWIDTH TEST	67
7.1 APPLIED PROCEDURES / LIMIT	67
7.1.1 TEST PROCEDURE	67
7.1.2 DEVIATION FROM STANDARD	67
7.1.3 TEST SETUP	67
7.1.4 EUT OPERATION CONDITIONS	67
7.1.5 TEST RESULTS	68
8 . PEAK OUTPUT POWER TEST	74
8.1 APPLIED PROCEDURES / LIMIT	74
8.1.1 TEST PROCEDURE	74
8.1.2 DEVIATION FROM STANDARD	74
8.1.3 TEST SETUP	74
8.1.4 EUT OPERATION CONDITIONS	74
8.1.5 TEST RESULTS	75
9 . ANTENNA REQUIREMENT	81
9.1 STANDARD REQUIREMENT	81
9.2 EUT ANTENNA	81
10 . EUT TEST PHOTO	82
APPENDIX-PHOTOGRAPHS OF EUT CONSTRUCTIONAL DETAILS	

1. SUMMARY OF TEST RESULTS

Test procedures according to the technical standards:

FCC Part15 (15.247) , Subpart C			
Standard Section	Test Item	Judgment	Remark
15.207	Conducted Emission	PASS	
15.247(a)(1)	Hopping Channel Separation	PASS	
15.247(b)(1)	Peak Output Power	PASS	
15.247(c)	Radiated Spurious Emission	PASS	
15.247(a)(iii)	Number of Hopping Frequency	PASS	
15.247(a)(iii)	Dwell Time	PASS	
15.247(a)(1)	Bandwidth	PASS	
15.205	Band Edge Emission	PASS	
15.203	Antenna Requirement	PASS	

NOTE:

(1) "N/A" denotes test is not applicable in this Test Report

1.1 TEST FACILITY

NTEK Testing Technology Co., Ltd

Add. : 1/F, Building E, Fenda Science Park, Sanwei Community, Xixiang Street, Bao'an District, Shenzhen P.R. China.

FCC Registration No.:238937; IC Registration No.:9270A-1

CNAS Registration No.:L5516

1.2 MEASUREMENT UNCERTAINTY

The reported uncertainty of measurement $y \pm U$, where expanded uncertainty U is based on a standard uncertainty multiplied by a coverage factor of $k=2$, providing a level of confidence of approximately 95%.

No.	Item	Uncertainty
1	Conducted Emission Test	$\pm 1.38\text{dB}$
2	RF power,conducted	$\pm 0.16\text{dB}$
3	Spurious emissions,conducted	$\pm 0.21\text{dB}$
4	All emissions,radiated(<1G)	$\pm 4.68\text{dB}$
5	All emissions,radiated(>1G)	$\pm 4.89\text{dB}$
6	Temperature	$\pm 0.5^\circ\text{C}$
7	Humidity	$\pm 2\%$

2. GENERAL INFORMATION

2.1 GENERAL DESCRIPTION OF EUT

Equipment	38" sound bar 2.1 system with wireless subwoofer	
Trade Name	VIZIO	
Model Name	S3821w-C0	
Serial Model	S3821w-xxx("x" is "A-Z" or "0-9" or "Blank")	
Model Difference	All the model are the same circuit and RF module,except the packaging.	
Product Description	The EUT is a 38" sound bar 2.1 system with wireless subwoofer	
	Operation Frequency:	2402~2480 MHz
	Modulation Type:	BT(1Mbps): GFSK BT EDR(2Mbps): Π/4-DQPSK BT EDR(3Mbps): 8-DPSK
	Bit Rate of Transmitter	1Mbps/2Mbps/3Mbps
	Number Of Channel	79 CH
	Antenna Designation:	Please see Note 3.
	Output Power(Conducted):	BT(1Mbps): 1.070dBm BT EDR(2Mbps): -1.142dBm BT EDR(3Mbps): -0.855dBm
	Operation Frequency:	2405.376~2475.008MHz
	Modulation Type:	GFSK
	Antenna Designation:	PCB Antenna
	Antenna Gain(Peak)	0.8 dBi
	Field Strength (at what distance):	88.07dbuv/m@3m(AVG)
	Based on the application, features, or specification exhibited in User's Manual, the EUT is considered as an ITE/Computing Device. More details of EUT technical specification, please refer to the User's Manual.	
	Channel List	Please refer to the Note 2.
Adapter	N/A	
Battery	N/A	
Connecting I/O Port(s)	Please refer to the User's Manual	

Note:

1. For a more detailed features description, please refer to the manufacturer's specifications or the User's Manual.

2.

Channel List					
Channel	Frequency (MHz)	Channel	Frequency (MHz)	Channel	Frequency (MHz)
00	2402	27	2429	54	2456
01	2403	28	2430	55	2457
02	2404	29	2431	56	2458
03	2405	30	2432	57	2459
04	2406	31	2433	58	2460
05	2407	32	2434	59	2461
06	2408	33	2435	60	2462
07	2409	34	2436	61	2463
08	2410	35	2437	62	2464
09	2411	36	2438	63	2465
10	2412	37	2439	64	2466
11	2413	38	2440	65	2467
12	2414	39	2441	66	2468
13	2415	40	2442	67	2469
14	2416	41	2443	68	2470
15	2417	42	2444	69	2471
16	2418	43	2445	70	2472
17	2419	44	2446	71	2473
18	2420	45	2447	72	2474
19	2421	46	2448	73	2475
20	2422	47	2449	74	2476
21	2423	48	2450	75	2477
22	2424	49	2451	76	2478
23	2425	50	2452	77	2479
24	2426	51	2453	78	2480
25	2427	52	2454		
26	2428	53	2455		

3.

Table for Filed Antenna

Ant	Brand	Model Name	Antenna Type	Connector	Gain (dBi)	NOTE
1	N/A	N/A	PCB Antenna	N/A	0.8	BT Antenna

2.2 DESCRIPTION OF TEST MODES

To investigate the maximum EMI emission characteristics generates from EUT, the test system was pre-scanning tested base on the consideration of following EUT operation mode or test configuration mode which possible have effect on EMI emission level. Each of these EUT operation mode(s) or test configuration mode(s) mentioned above was evaluated respectively.

Pretest Mode	Description
Mode 1	CH00
Mode 2	CH39
Mode 3	CH78
Mode 4	BT Link

For Conducted Emission	
Final Test Mode	Description
Mode 4	BT Link

For Radiated Emission	
Final Test Mode	Description
Mode 1	CH00
Mode 2	CH39
Mode 3	CH78
Mode 4	BT Link

Note:

- (1) The measurements are performed at the highest, middle, lowest available channels.
- (2) The EUT use new battery.

2.3 TABLE OF PARAMETERS OF TEXT SOFTWARE SETTING

During testing channel & power controlling software provided by the customer was used to control the operating channel as well as the output power level. The RF output power selection is for the setting of RF output power expected by the customer and is going to be fixed on the firmware of the final end product power parameters of FHSS

Test software Version	Test program: Broadcom		
Frequency	2402 MHz	2441 MHz	2480 MHz
Parameters(1Mbps)	DEF	DEF	DEF
Parameters(2Mbps)	DEF	DEF	DEF
Parameters(3Mbps)	DEF	DEF	DEF

2.4 BLOCK DIGRAM SHOWING THE CONFIGURATION OF SYSTEM TESTED

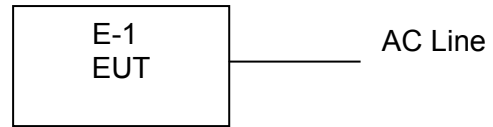

2.5 DESCRIPTION OF SUPPORT UNITS(CONDUCTED MODE)

The EUT has been tested as an independent unit together with other necessary accessories or support units. The following support units or accessories were used to form a representative test configuration during the tests.

Item	Equipment	Mfr/Brand	Model/Type No.	Series No.	Note
E-1	EUT	VIZIO	S3821w-C0	N/A	EUT

Item	Shielded Type	Ferrite Core	Length	Note

Note:

- (1) The support equipment was authorized by Declaration of Confirmation.
- (2) For detachable type I/O cable should be specified the length in cm in 『Length』 column.
- (3) “YES” is means “shielded” “with core”; “NO” is means “unshielded” “without core”.

2.6 EQUIPMENTS LIST FOR ALL TEST ITEMS

Radiation Test equipment

Item	Kind of Equipment	Manufacturer	Type No.	Serial No.	Last calibration	Calibrated until	Calibration period
1	Spectrum Analyzer	Agilent	E4407B	MY45108040	2012.07.06	2013.07.05	1 year
2	Test Receiver	R&S	ESPI	101318	2012.06.07	2013.06.06	1 year
3	Bilog Antenna	TESEQ	CBL6111D	31216	2012.07.06	2013.07.05	1 year
4	50Ω Coaxial Switch	Anritsu	MP59B	6200264416	2012.06.07	2013.06.06	1 year
5	Spectrum Analyzer	ADVANTEST	R3132	150900201	2012.06.07	2013.06.06	1 year
6	Horn Antenna	EM	EM-AH-10180	2011071402	2012.07.06	2013.07.05	1 year
7	Horn Ant	Schwarzbeck	BBHA 9170	9170-181	2012.07.06	2013.07.05	1 year
8	Amplifier	EM	EM-30180	060538	2012.12.22	2013.12.21	1 year
9	Loop Antenna	ARA	PLA-1030/B	1029	2012.06.08	2013.06.07	1 year
10	Power Meter	R&S	NRVS	100696	2012.07.06	2013.07.05	1 year
11	Power Sensor	R&S	URV5-Z4	0395.1619.05	2012.07.06	2013.07.05	1 year

Conduction Test equipment

Item	Kind of Equipment	Manufacturer	Type No.	Serial No.	Last calibration	Calibrated until	Calibration period
1	Test Receiver	R&S	ESCI	101160	2012.06.06	2013.06.05	1 year
2	LISN	R&S	ENV216	101313	2012.08.24	2013.08.23	1 year
3	LISN	EMCO	3816/2	00042990	2012.08.24	2013.08.23	1 year
4	50Ω Coaxial Switch	Anritsu	MP59B	6200264417	2012.06.07	2013.06.06	1 year
5	Passive Voltage Probe	R&S	ESH2-Z3	100196	2012.06.07	2013.06.06	1 year
6	Absorbing clamp	R&S	MOS-21	100423	2012.06.08	2013.06.07	1 year

3. EMC EMISSION TEST

3.1 CONDUCTED EMISSION MEASUREMENT

3.1.1 POWER LINE CONDUCTED EMISSION Limits (Frequency Range 150KHz-30MHz)

FREQUENCY (MHz)	Class A (dBuV)		Class B (dBuV)		Standard
	Quasi-peak	Average	Quasi-peak	Average	
0.15 -0.5	79.00	66.00	66 - 56 *	56 - 46 *	CISPR
0.50 -5.0	73.00	60.00	56.00	46.00	CISPR
5.0 -30.0	73.00	60.00	60.00	50.00	CISPR

0.15 -0.5	79.00	66.00	66 - 56 *	56 - 46 *	FCC
0.50 -5.0	73.00	60.00	56.00	46.00	FCC
5.0 -30.0	73.00	60.00	60.00	50.00	FCC

Note:

- (1) The tighter limit applies at the band edges.
- (2) The limit of " * " marked band means the limitation decreases linearly with the logarithm of the frequency in the range.

The following table is the setting of the receiver

Receiver Parameters	Setting
Attenuation	10 dB
Start Frequency	0.15 MHz
Stop Frequency	30 MHz
IF Bandwidth	9 kHz

3.1.2 TEST PROCEDURE

- The EUT was placed 0.4 meters from the horizontal ground plane with EUT being connected to the power mains through a line impedance stabilization network (LISN). All other support equipments powered from additional LISN(s). The LISN provide 50 Ohm/ 50uH of coupling impedance for the measuring instrument.
- Interconnecting cables that hang closer than 40 cm to the ground plane shall be folded back and forth in the center forming a bundle 30 to 40 cm long.
- I/O cables that are not connected to a peripheral shall be bundled in the center. The end of the cable may be terminated, if required, using the correct terminating impedance. The overall length shall not exceed 1 m.
- LISN at least 80 cm from nearest part of EUT chassis.
- For the actual test configuration, please refer to the related Item –EUT Test Photos.

3.1.3 DEVIATION FROM TEST STANDARD

No deviation

3.1.4 TEST SETUP

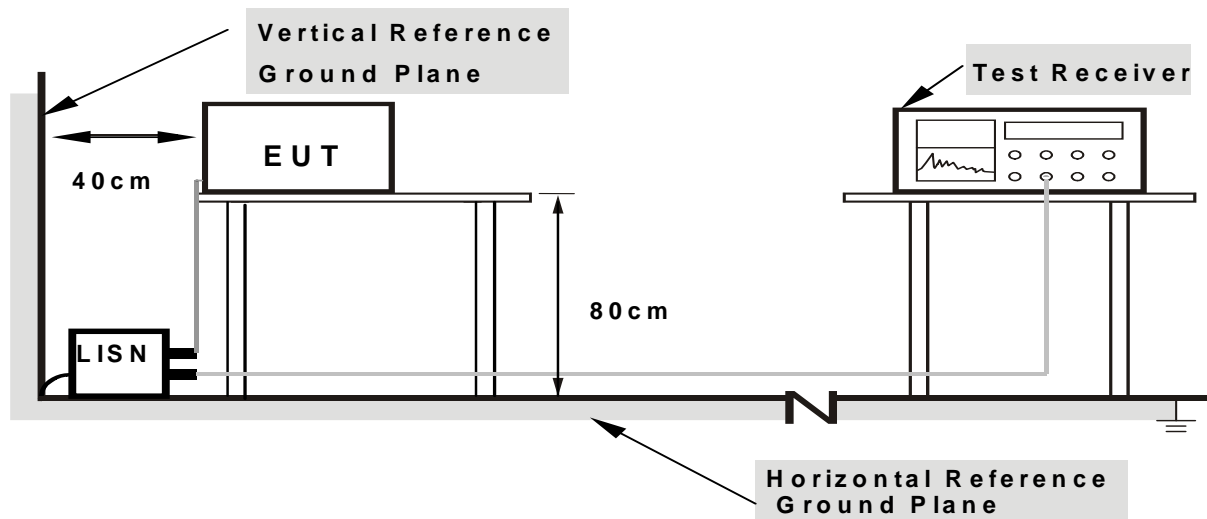

Note: 1.Support units were connected to second LISN.

2.Both of LISNs (AMN) are 80 cm from EUT and at least 80 from other units and other metal planes

3.1.5 EUT OPERATING CONDITIONS

The EUT was configured for testing in a typical fashion (as a customer would normally use it). The EUT has been programmed to continuously transmit during test. This operating condition was tested and used to collect the included data.

3.1.6 TEST RESULTS

EUT :	38" sound bar 2.1 system with wireless subwoofer	Model Name :	S3821w-C0
Temperature :	26 °C	Relative Humidity :	54%
Pressure :	1010hPa	Phase :	L
Test Voltage :	AC 120V/60Hz	Test Mode :	Mode 4

Frequency (MHz)	Reading Level (dBμV)	Correct Factor (dB)	Measure-ment (dBμV)	Limits (dBμV)	Margin (dB)	Detector Type
0.1539	51.81	9.82	61.63	65.78	-4.15	QP
0.1539	42.38	9.82	52.20	55.78	-3.58	AVG
0.3820	36.56	10.03	46.59	58.23	-11.64	QP
0.3820	28.62	10.03	38.65	48.23	-9.58	AVG
1.5420	32.67	10.20	42.87	56.00	-13.13	QP
1.5420	17.71	10.20	27.91	46.00	-18.09	AVG

Remark:

1. All readings are Quasi-Peak and Average values.
2. Factor = Insertion Loss + Cable Loss.

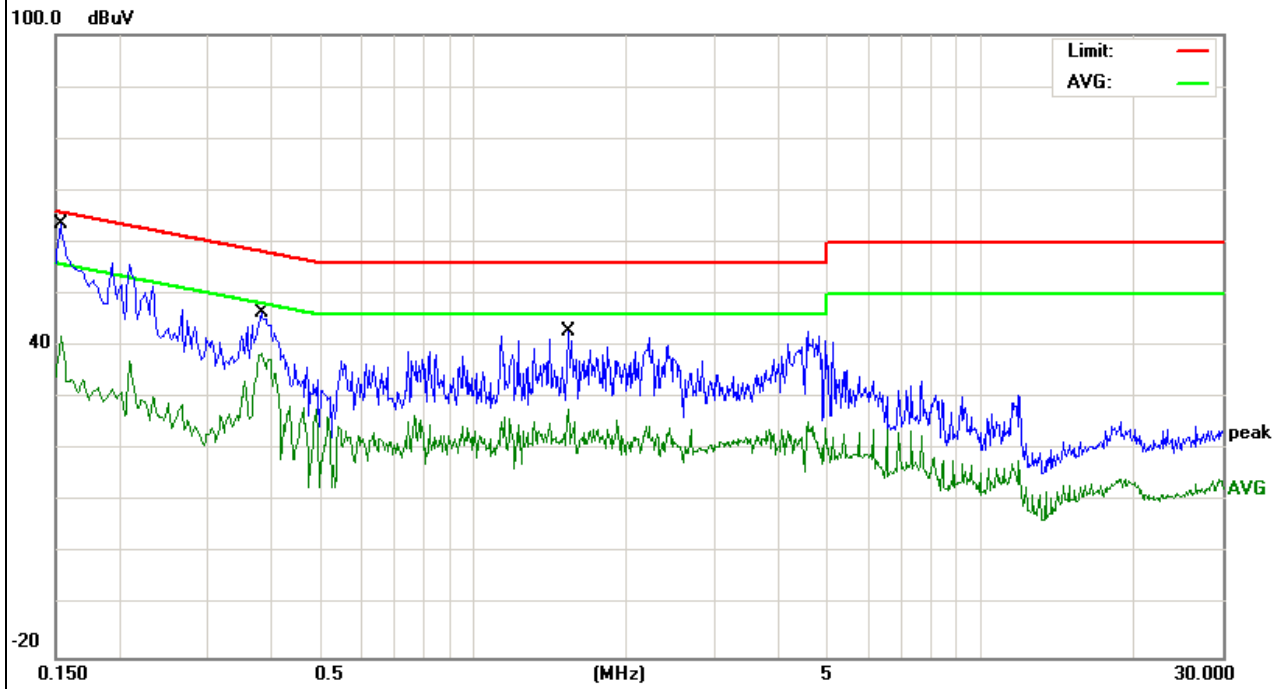

EUT :	38" sound bar 2.1 system with wireless subwoofer	Model Name :	S3821w-C0
Temperature :	26 °C	Relative Humidity :	54%
Pressure :	1010hPa	Phase :	N
Test Voltage :	AC 120V/60Hz	Test Mode :	Mode 4

Frequency (MHz)	Reading Level (dBμV)	Correct Factor (dB)	Measure-ment (dBμV)	Limits (dBμV)	Margin (dB)	Detector Type
0.1499	41.98	9.82	51.80	66.00	-14.20	QP
0.1499	29.66	9.82	39.48	56.00	-16.52	AVG
0.3820	35.07	10.20	45.27	58.23	-12.96	QP
0.3820	28.69	10.20	38.89	48.23	-9.34	AVG
0.7660	22.52	10.23	32.75	56.00	-23.25	QP
0.7660	14.19	10.23	24.42	46.00	-21.58	AVG
6.5300	24.96	10.34	35.30	60.00	-24.70	QP
6.5300	15.83	10.34	26.17	50.00	-23.83	AVG

Remark:

1. All readings are Quasi-Peak and Average values.
2. Factor = Insertion Loss + Cable Loss.
3. '*' means the worst case

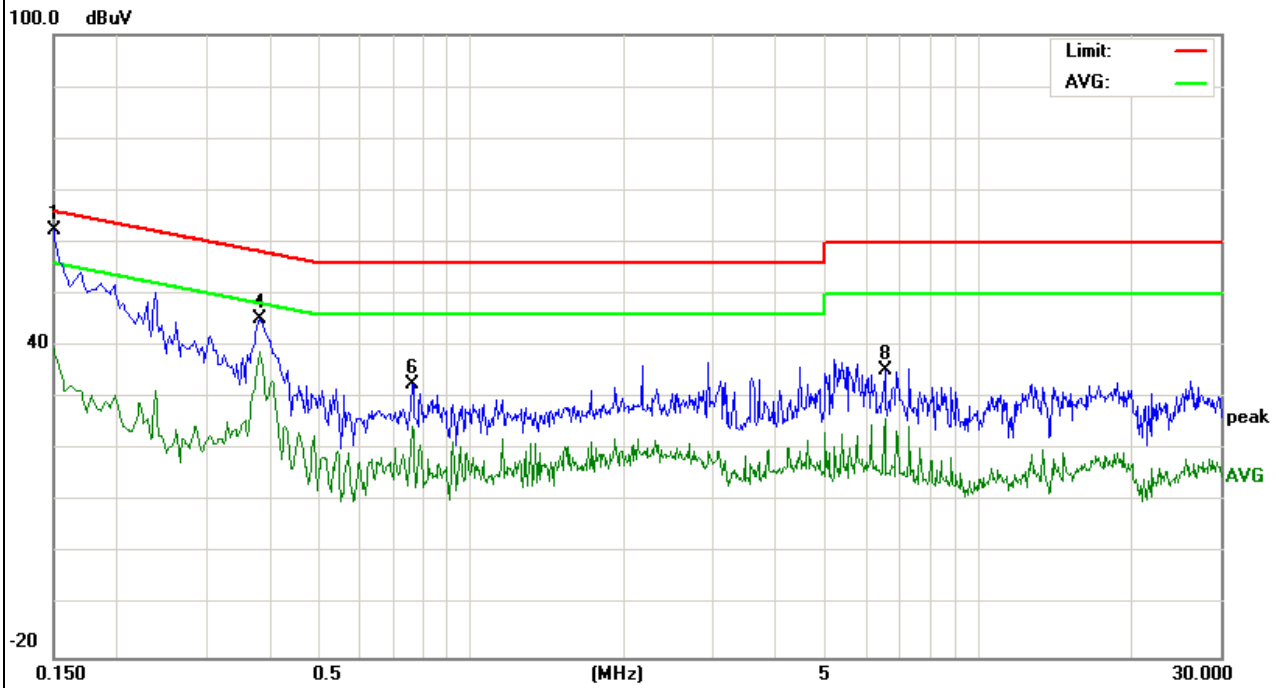

3.2 RADIATED EMISSION MEASUREMENT

3.2.1 RADIATED EMISSION LIMITS (Frequency Range 9kHz-1000MHz)

20dBc in any 100 kHz bandwidth outside the operating frequency band. In case the emission fall within the restricted band specified on 15.205(a), then the 15.209(a) limit in the table below has to be followed.

Frequencies (MHz)	Field Strength (micorvolts/meter)	Measurement Distance (meters)
0.009~0.490	2400/F(KHz)	300
0.490~1.705	24000/F(KHz)	30
1.705~30.0	30	30
30~88	100	3
88~216	150	3
216~960	200	3
Above 960	500	3

LIMITS OF RADIATED EMISSION MEASUREMENT (Above 1000MHz)

FREQUENCY (MHz)	Class A (dBuV/m) (at 3M)		Class B (dBuV/m) (at 3M)	
	PEAK	AVERAGE	PEAK	AVERAGE
Above 1000	80	60	74	54

Notes:

- (1) The limit for radiated test was performed according to FCC PART 15C.
- (2) The tighter limit applies at the band edges.
- (3) Emission level (dBuV/m)=20log Emission level (uV/m).

FREQUENCY RANGE OF RADIATED MEASUREMENT (For unintentional radiators)

Highest frequency generated or Upper frequency of measurement used in the device or on which the device operates or tunes (MHz)	Range (MHz)
Below 1.705	30
1.705 – 108	1000
108 – 500	2000
500 – 1000	5000
Above 1000	5 th harmonic of the highest frequency or 40 GHz, whichever is lower

Spectrum Parameter	Setting
Attenuation	Auto
Start Frequency	1000 MHz
Stop Frequency	10th carrier harmonic
RB / VB (emission in restricted band)	1 MHz / 1 MHz for Peak, 1 MHz / 10Hz for Average

Receiver Parameter	Setting
Attenuation	Auto
Start ~ Stop Frequency	9kHz~150kHz / RB 200Hz for QP
Start ~ Stop Frequency	150kHz~30MHz / RB 9kHz for QP
Start ~ Stop Frequency	30MHz~1000MHz / RB 120kHz for QP

3.2.2 TEST PROCEDURE

- a. The measuring distance of at 3 m shall be used for measurements at frequency up to 1GHz. For frequencies above 1GHz, any suitable measuring distance may be used.
- b. The EUT was placed on the top of a rotating table 0.8 meters above the ground at a 3 meter open area test site. The table was rotated 360 degrees to determine the position of the highest radiation.
- c. The height of the equipment or of the substitution antenna shall be 0.8 m; the height of the test antenna shall vary between 1 m to 4 m. Both horizontal and vertical polarizations of the antenna are set to make the measurement.
- d. The initial step in collecting conducted emission data is a spectrum analyzer peak detector mode pre-scanning the measurement frequency range. Significant peaks are then marked and then Quasi Peak detector mode re-measured.
- e. If the Peak Mode measured value compliance with and lower than Quasi Peak Mode Limit, the EUT shall be deemed to meet QP Limits and then no additional QP Mode measurement performed.
- f. For the actual test configuration, please refer to the related Item –EUT Test Photos.

Note:

Both horizontal and vertical antenna polarities were tested and performed pretest to three orthogonal axis. The worst case emissions were reported

3.2.3 DEVIATION FROM TEST STANDARD

No deviation

3.2.4 TEST SETUP

(A) Radiated Emission Test-Up Frequency Below 30MHz

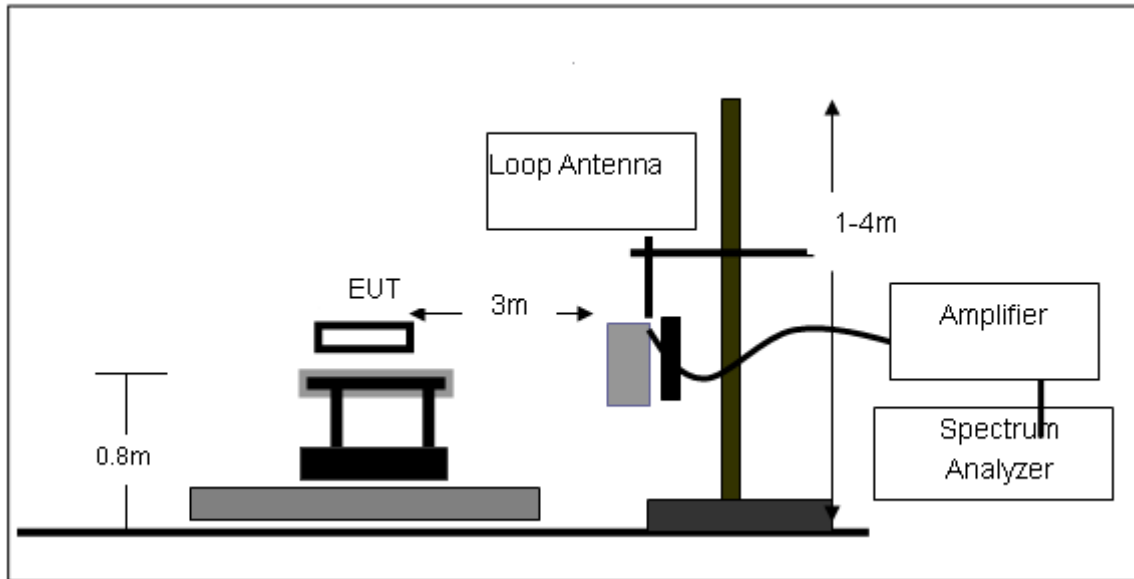

(B) Radiated Emission Test-Up Frequency 30MHz~1GHz

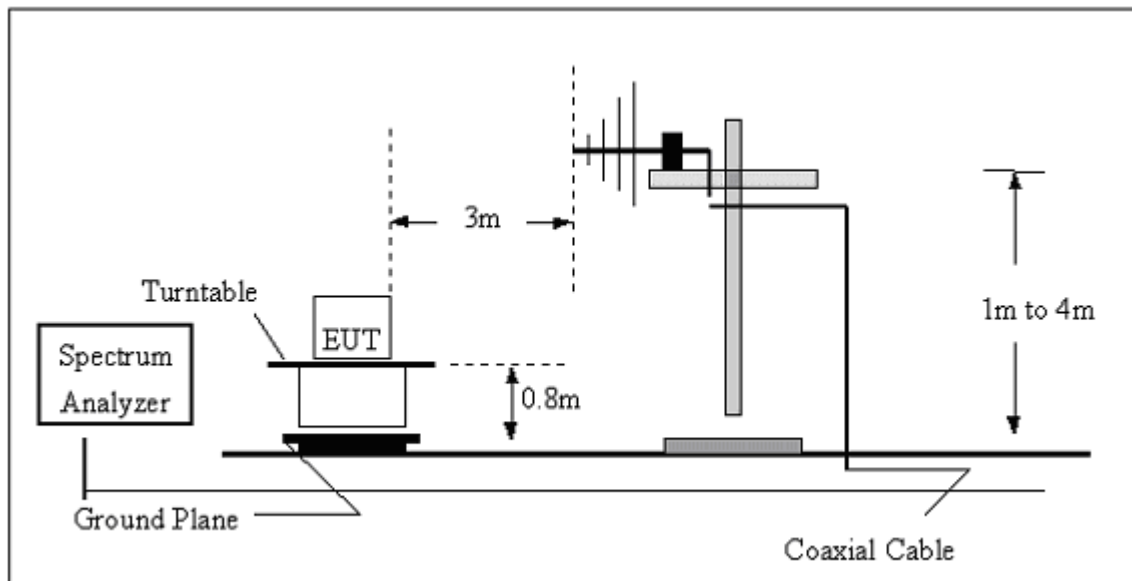

(C) Radiated Emission Test-Up Frequency Above 1GHz

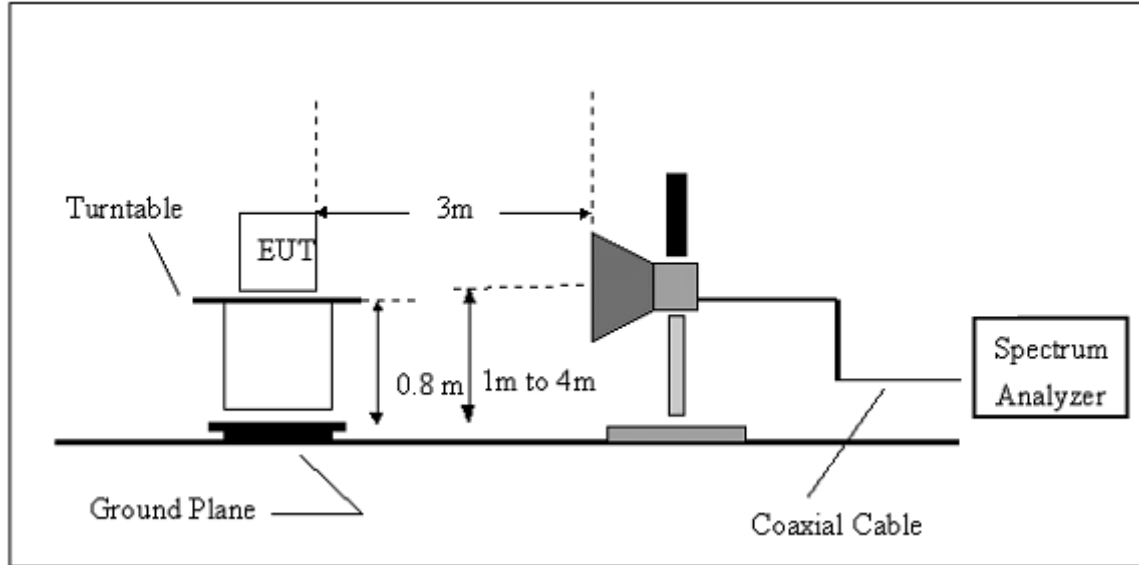

3.2.5 EUT OPERATING CONDITIONS

The EUT tested system was configured as the statements of 2.4 Unless otherwise a special operating condition is specified in the follows during the testing.

3.2.6 TEST RESULTS (BELOW 30 MHZ)

EUT :	38" sound bar 2.1 system with wireless subwoofer	Model Name :	S3821w-C0
Temperature :	20 °C	Relative Humidity :	48%
Pressure :	1010 hPa	Polarization :	---
Test Voltage :	AC 120V/60Hz		
Test Mode :	Mode 1		

Freq.	Reading	Limit	Margin	State
(MHz)	(dBuV/m)	(dBuV/m)	(dB)	P/F
--	--	--	--	PASS
--	--	--	--	PASS

NOTE:

The amplitude of spurious emissions which are attenuated by more than 20dB below the permissible value has no need to be reported.

Distance extrapolation factor = $40 \log(\text{specific distance}/\text{test distance})(\text{dB})$;

Limit line = specific limits(dBuv) + distance extrapolation factor.

3.2.7 TEST RESULTS (BETWEEN 30M – 1000 MHZ)

EUT :	38" sound bar 2.1 system with wireless subwoofer	Model Name :	S3821w-C0
Temperature :	20 °C	Relative Humidity :	48%
Pressure :	1010 hPa	Polarization :	Horizontal
Test Voltage :	AC 120V/60Hz		
Test Mode :	Mode 4		

Frequency (MHz)	Meter Reading (dBμV)	Factor (dB)	Emission Level (dBμV/m)	Limits (dBμV/m)	Margin (dB)	Detector Type
58.6126	17.02	5.50	22.52	40.00	-17.48	QP
134.5592	22.90	12.25	35.15	43.50	-8.35	QP
159.7844	28.22	11.02	39.24	43.50	-4.26	QP
166.6514	27.35	10.68	38.03	42.50	-5.47	QP

Remark:
Factor = Antenna Factor + Cable Loss – Pre-amplifier.

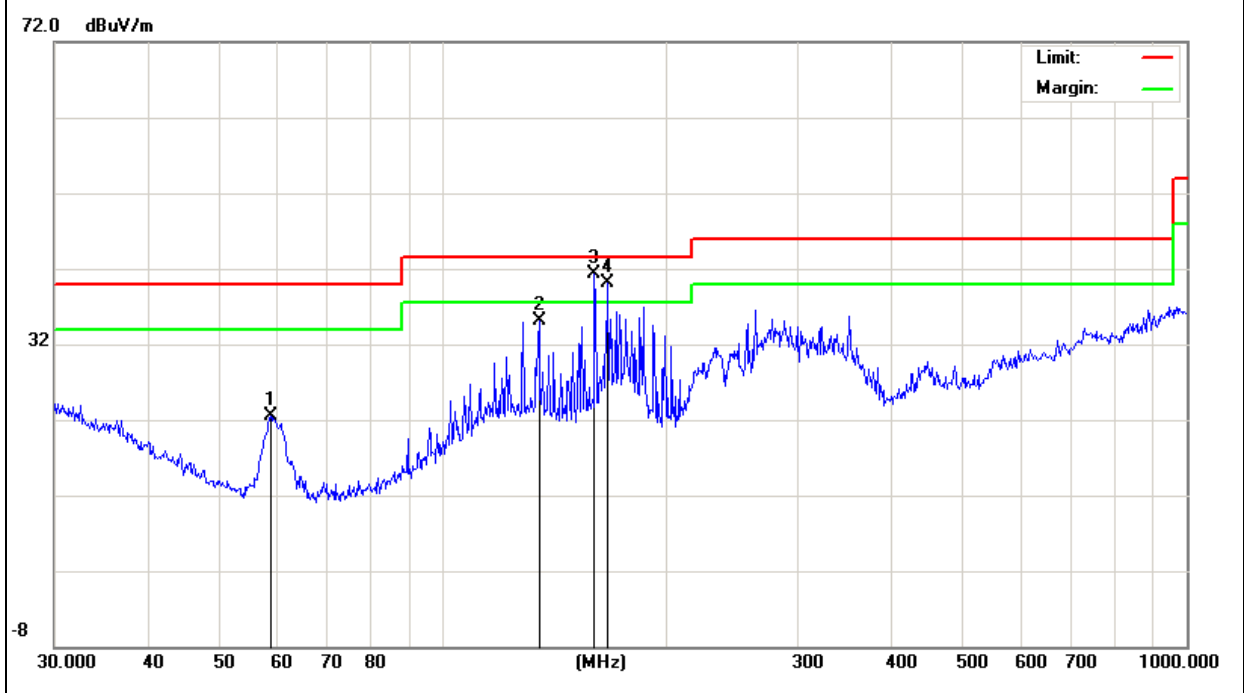

EUT :	38" sound bar 2.1 system with wireless subwoofer	Model Name :	S3821w-C0
Temperature :	20 °C	Relative Humidity :	48%
Pressure :	1010 hPa	Polarization :	Vertical
Test Voltage :	AC 120V/60Hz		
Test Mode :	Mode 4		

Frequency (MHz)	Meter Reading (dBµV)	Factor (dB)	Emission Level (dBµV/m)	Limits (dBµV/m)	Margin (dB)	Detector Type
36.3814	15.75	15.19	30.94	40.00	-9.06	QP
58.8185	23.30	5.48	28.78	40.00	-11.22	QP
103.0800	17.54	10.92	28.46	43.50	-15.04	QP
170.7926	20.87	10.35	31.22	43.50	-12.28	QP

Remark:
Factor = Antenna Factor + Cable Loss – Pre-amplifier.

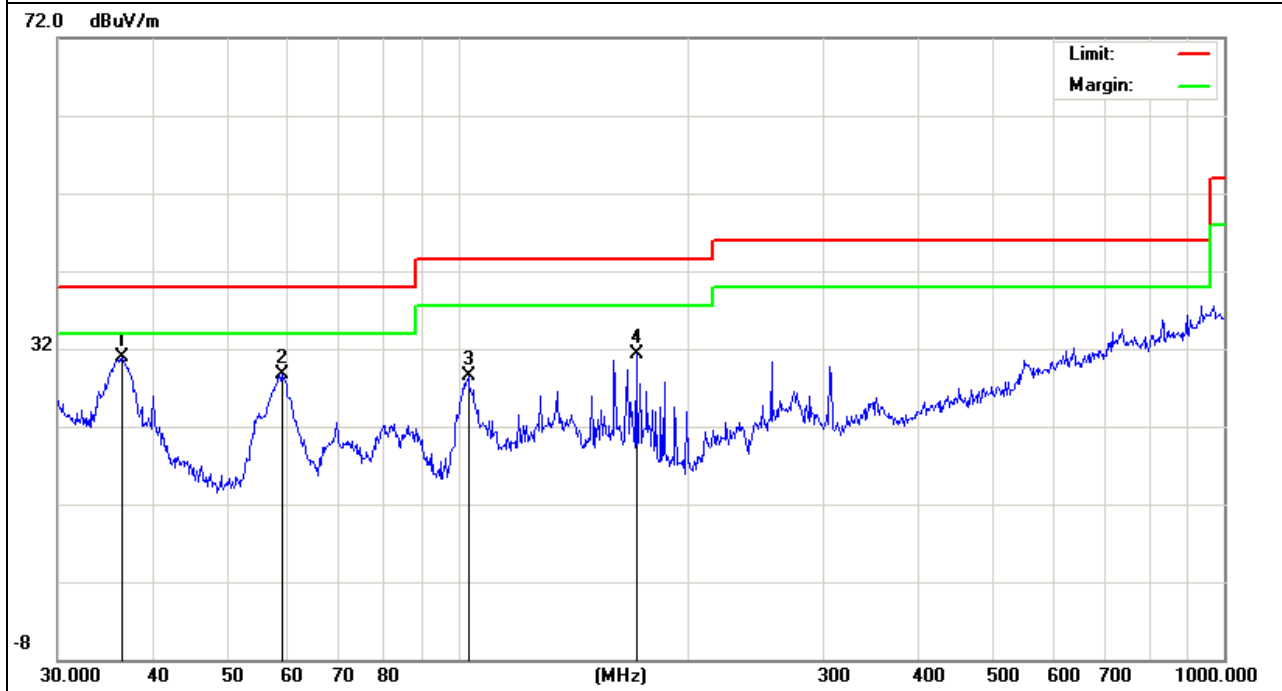

3.2.8 TEST RESULTS (ABOVE 1000 MHZ)

EUT :	38" sound bar 2.1 system with wireless subwoofer	Model Name :	S3821w-C0
Temperature :	20 °C	Relative Humidity :	48%
Pressure :	1010 hPa	Test Voltage :	AC 120V/60Hz
Test Mode :	TX 2402MHz – CH 00(1Mbps)	Polarization :	Horizontal

Frequency (MHz)	Meter Reading (dBμV)	Factor (dB)	Emission Level (dBμV/m)	Limits (dBμV/m)	Margin (dB)	Detector Type
1170	72.67	-18.54	54.13	74	-19.87	peak
1170	56.16	-18.54	37.62	54	-16.38	AVG
4804	61.45	-3.64	57.81	74	-16.19	peak
4804	45.46	-3.64	41.82	54	-12.18	AVG
7206	50.91	-0.95	49.96	74	-24.04	peak

Remark:

Factor = Antenna Factor + Cable Loss – Pre-amplifier.

No emission above 18GHz

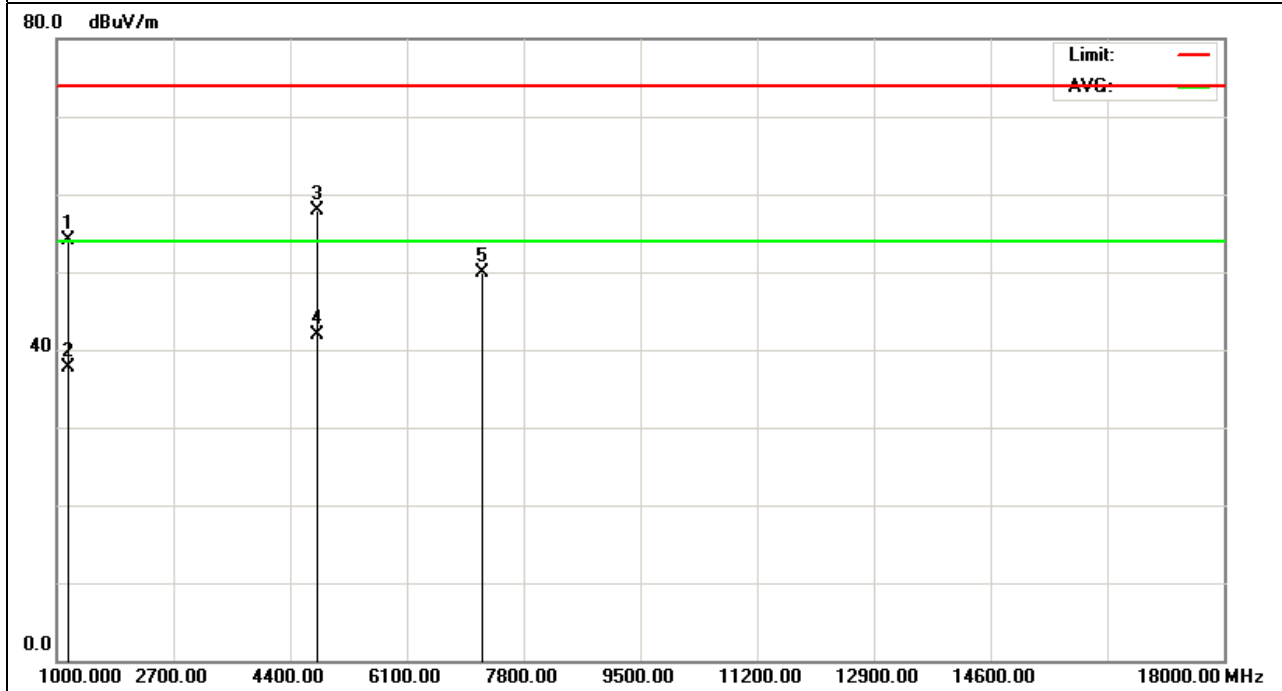

EUT :	38" sound bar 2.1 system with wireless subwoofer	Model Name :	S3821w-C0
Temperature :	20 °C	Relative Humidity :	48%
Pressure :	1010 hPa	Test Voltage :	AC 120V/60Hz
Test Mode :	TX 2402MHz – CH 00(1Mbps)	Polarization :	Vertical

Frequency (MHz)	Meter Reading (dBµV)	Factor (dB)	Emission Level (dBµV/m)	Limits (dBµV/m)	Margin (dB)	Detector Type
1170	80.27	-18.54	61.73	74	-12.27	peak
1170	57.09	-18.54	38.55	54	-15.45	AVG
4804	59.97	-3.64	56.33	74	-17.67	peak
7206	52.23	-0.95	51.28	74	-22.72	peak

Remark:
 Factor = Antenna Factor + Cable Loss – Pre-amplifier.
 No emission above 18GHz

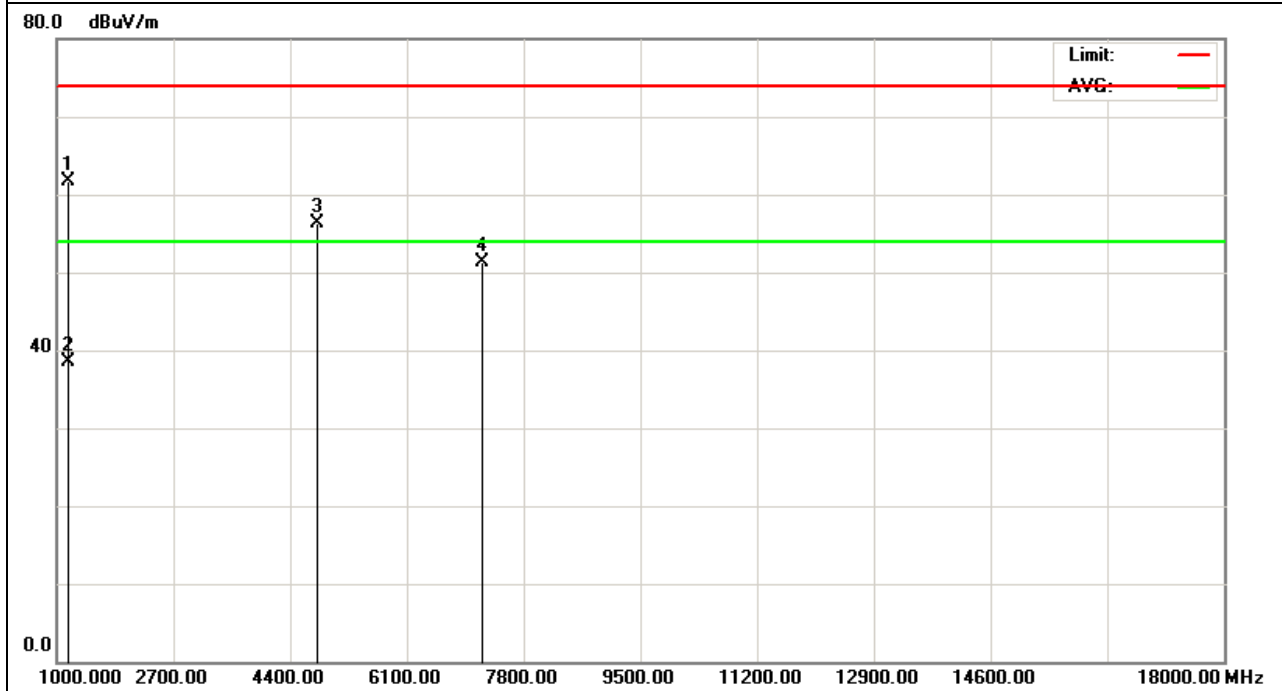

EUT :	38" sound bar 2.1 system with wireless subwoofer	Model Name :	S3821w-C0
Temperature :	20 °C	Relative Humidity :	48%
Pressure :	1010 hPa	Test Voltage :	AC 120V/60Hz
Test Mode :	TX 2441MHz – CH 39(1Mbps)	Polarization :	Vertical

Frequency (MHz)	Meter Reading (dBµV)	Factor (dB)	Emission Level (dBµV/m)	Limits (dBµV/m)	Margin (dB)	Detector Type
1170	71.82	-18.54	53.28	74	-20.72	peak
4882	58.98	-3.68	55.3	74	-18.7	peak
7323	50.88	-0.82	50.06	74	-23.94	peak

Remark:
 Factor = Antenna Factor + Cable Loss – Pre-amplifier.
 No emission above 18GHz

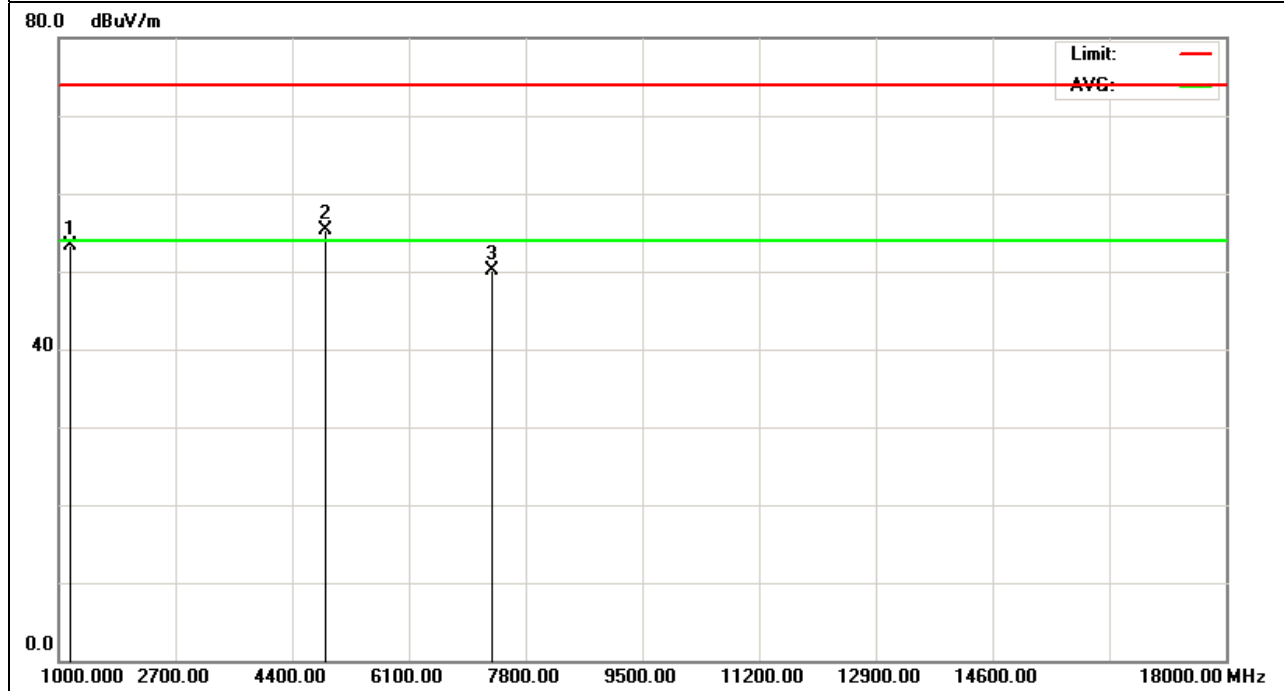

EUT :	38" sound bar 2.1 system with wireless subwoofer	Model Name :	S3821w-C0
Temperature :	20 °C	Relative Humidity :	48%
Pressure :	1010 hPa	Test Voltage :	AC 120V/60Hz
Test Mode :	TX 2441MHz – CH 39(1Mbps)	Polarization :	Horizontal

Frequency (MHz)	Meter Reading (dBµV)	Factor (dB)	Emission Level (dBµV/m)	Limits (dBµV/m)	Margin (dB)	Detector Type
1170	75.73	-18.54	57.19	74	-16.81	peak
1170	57.5	-18.54	38.96	54	-15.04	AVG
4882	57.55	-3.68	53.87	74	-20.13	peak

Remark:
 Factor = Antenna Factor + Cable Loss – Pre-amplifier.
 No emission above 18GHz

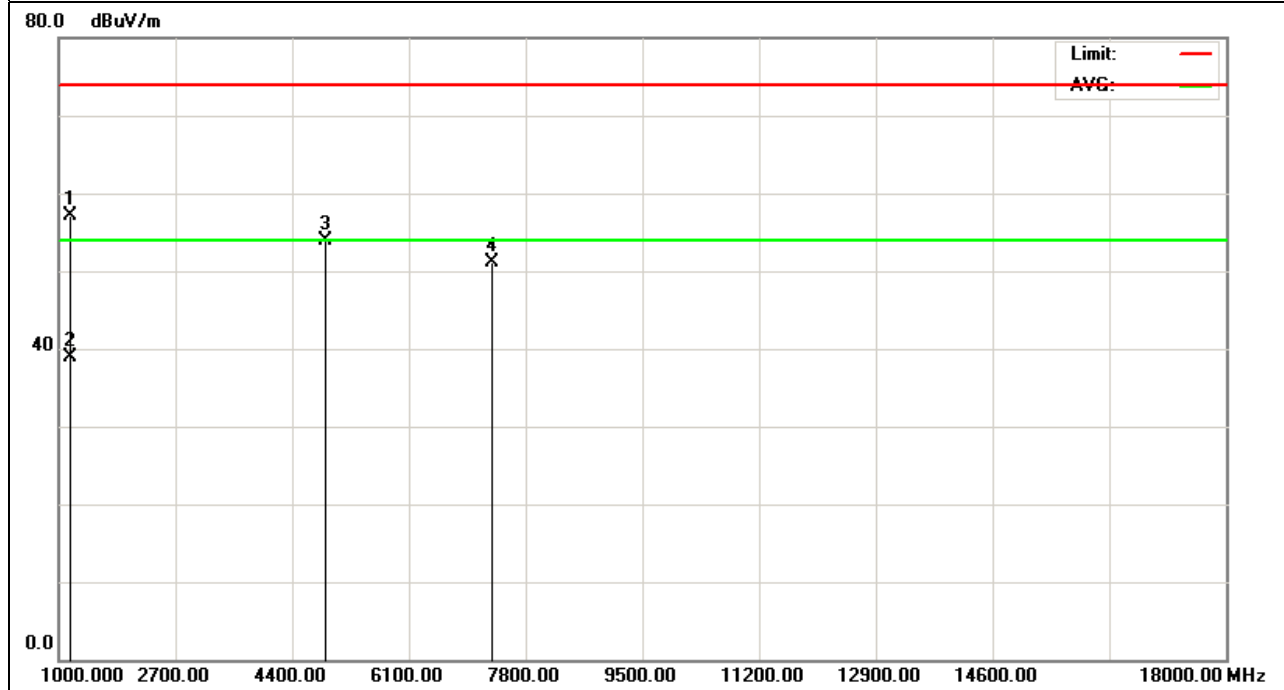

EUT :	38" sound bar 2.1 system with wireless subwoofer	Model Name :	S3821w-C0
Temperature :	20 °C	Relative Humidity :	48%
Pressure :	1010 hPa	Test Voltage :	AC 120V/60Hz
Test Mode :	TX 2480MHz – CH 78(1Mbps)	Polarization :	Horizontal

Frequency (MHz)	Meter Reading (dBµV)	Factor (dB)	Emission Level (dBµV/m)	Limits (dBµV/m)	Margin (dB)	Detector Type
1170	79.87	-18.54	61.33	74	-12.67	peak
1170	62.24	-18.54	43.7	54	-10.3	AVG
4960	51.91	-3.59	48.32	74	-25.68	peak
7440	51.57	-0.69	50.88	74	-23.12	peak

Remark:
 Factor = Antenna Factor + Cable Loss – Pre-amplifier.
 No emission above 18GHz

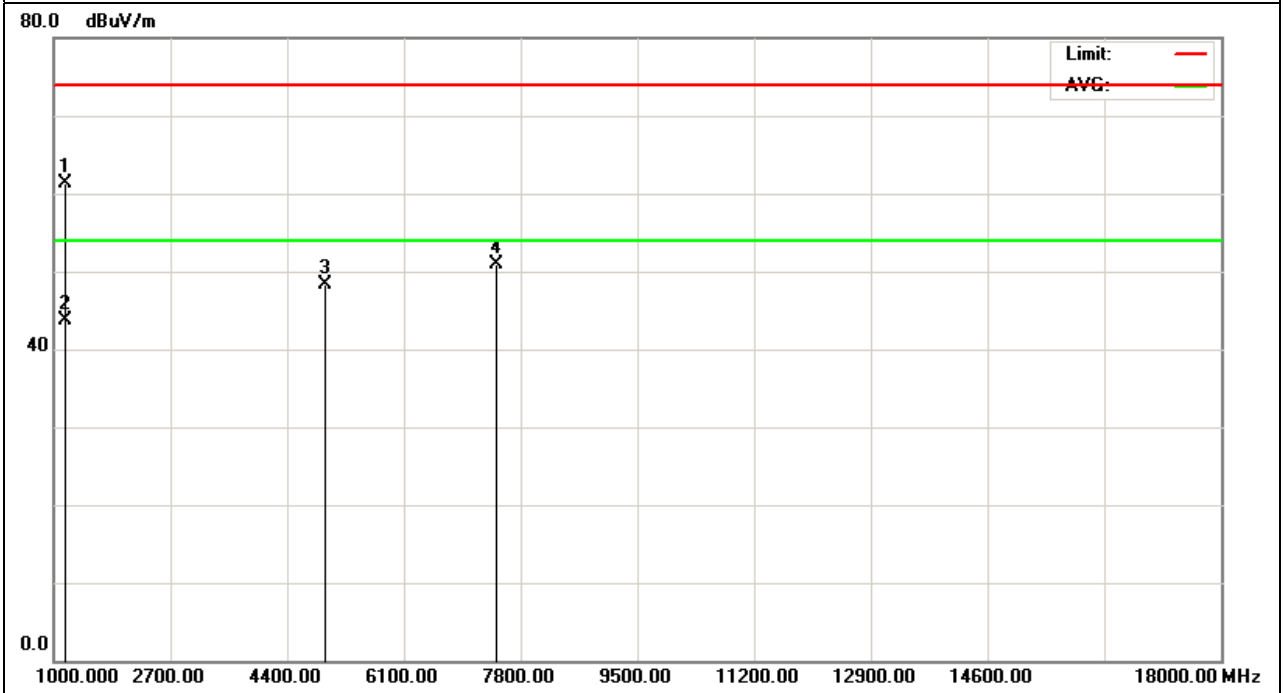

EUT :	38" sound bar 2.1 system with wireless subwoofer	Model Name :	S3821w-C0
Temperature :	20 °C	Relative Humidity :	48%
Pressure :	1010 hPa	Test Voltage :	AC 120V/60Hz
Test Mode :	TX 2480MHz – CH 78(1Mbps)	Polarization :	Vertical

Frequency (MHz)	Meter Reading (dBµV)	Factor (dB)	Emission Level (dBµV/m)	Limits (dBµV/m)	Margin (dB)	Detector Type
1170	72.88	-18.54	54.34	74	-19.66	peak
1170	56.43	-18.54	37.89	54	-16.11	AVG
4960	54.28	-3.59	50.69	74	-23.31	peak
7440	51.86	-0.69	51.17	74	-22.83	peak

Remark:
 Factor = Antenna Factor + Cable Loss – Pre-amplifier.
 No emission above 18GHz

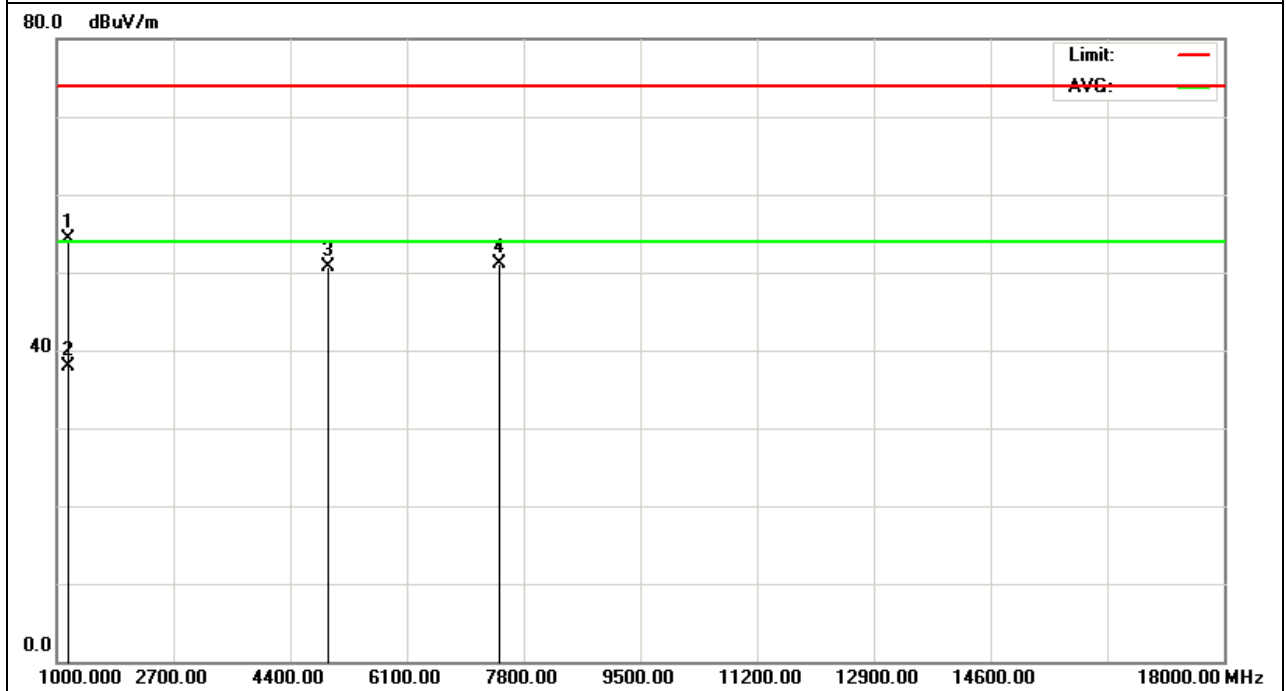

EUT :	38" sound bar 2.1 system with wireless subwoofer	Model Name :	S3821w-C0
Temperature :	20 °C	Relative Humidity :	48%
Pressure :	1010 hPa	Test Voltage :	AC 120V/60Hz
Test Mode :	TX 2402MHz – CH 00(2Mbps)	Polarization :	Horizontal

Frequency (MHz)	Meter Reading (dBµV)	Factor (dB)	Emission Level (dBµV/m)	Limits (dBµV/m)	Margin (dB)	Detector Type
1170	74.85	-18.54	56.31	74	-17.69	peak
1170	58.29	-18.54	39.75	54	-14.25	AVG
4804	56.4	-3.64	52.76	74	-21.24	peak
7206	52.5	-0.95	51.55	74	-22.45	peak

Remark:
 Factor = Antenna Factor + Cable Loss – Pre-amplifier.
 No emission above 18GHz

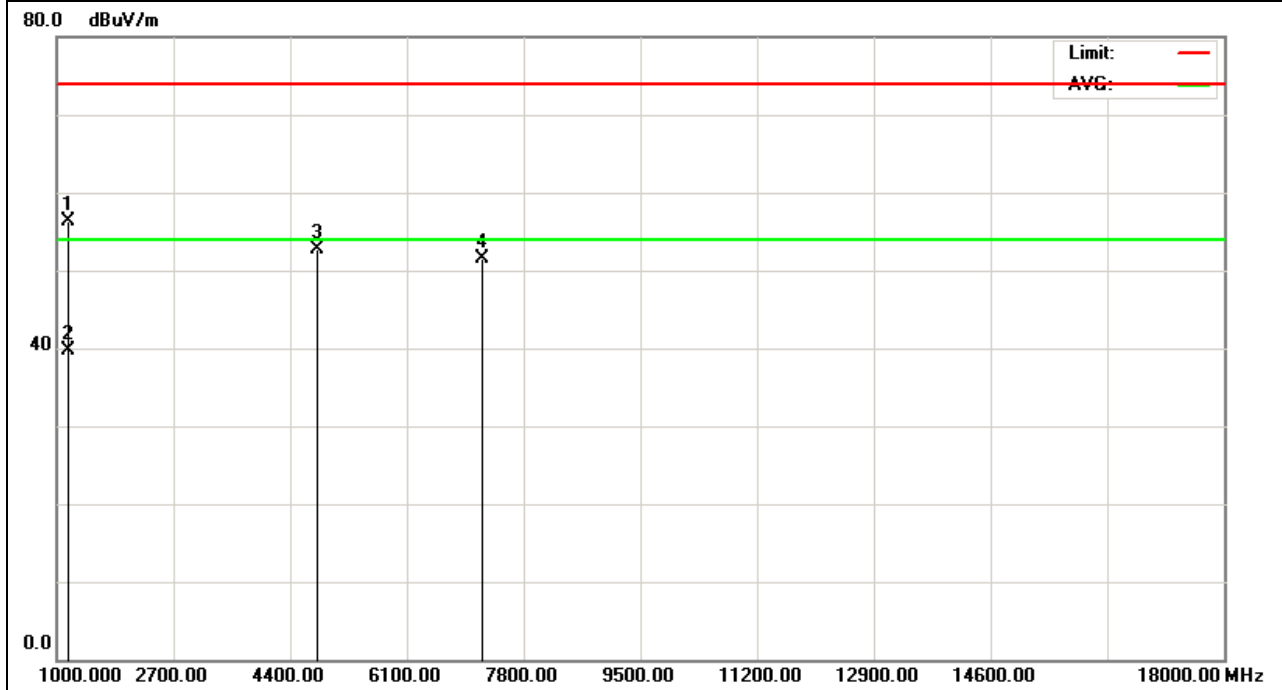

EUT :	38" sound bar 2.1 system with wireless subwoofer	Model Name :	S3821w-C0
Temperature :	20 °C	Relative Humidity :	48%
Pressure :	1010 hPa	Test Voltage :	AC 120V/60Hz
Test Mode :	TX 2402MHz – CH 00(2Mbps)	Polarization :	Vertical

Frequency (MHz)	Meter Reading (dBμV)	Factor (dB)	Emission Level (dBμV/m)	Limits (dBμV/m)	Margin (dB)	Detector Type
1170	74.26	-18.54	55.72	74	-18.28	peak
1170	59.07	-18.54	40.53	54	-13.47	AVG
4804	53.61	-3.64	49.97	74	-24.03	peak
7206	50.83	-0.95	49.88	74	-24.12	peak

Remark:
 Factor = Antenna Factor + Cable Loss – Pre-amplifier.
 No emission above 18GHz

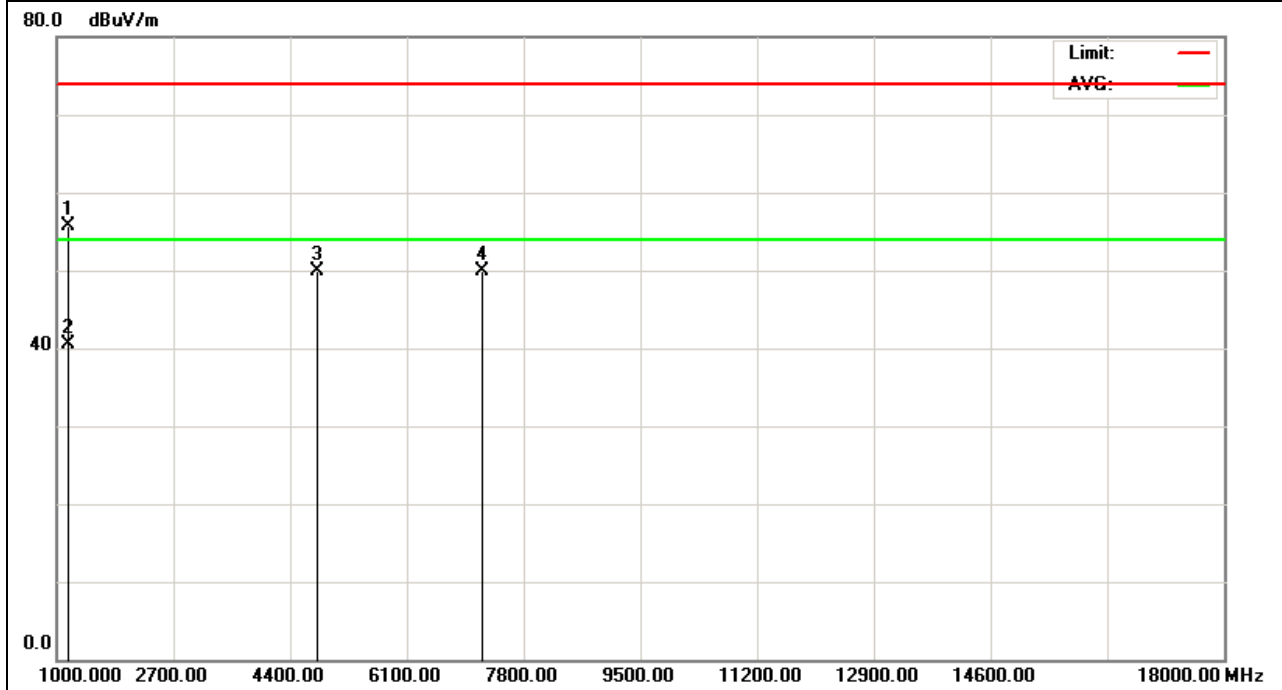

EUT :	38" sound bar 2.1 system with wireless subwoofer	Model Name :	S3821w-C0
Temperature :	20 °C	Relative Humidity :	48%
Pressure :	1010 hPa	Test Voltage :	AC 120V/60Hz
Test Mode :	TX 2441MHz – CH 39(2Mbps)	Polarization :	Horizontal

Frequency (MHz)	Meter Reading (dBμV)	Factor (dB)	Emission Level (dBμV/m)	Limits (dBμV/m)	Margin (dB)	Detector Type
1170	75.17	-18.54	56.63	74	-17.37	peak
1170	60.11	-18.54	41.57	54	-12.43	AVG
4882	53.29	-3.68	49.61	74	-24.39	peak
7323	50.93	-0.82	50.11	74	-23.89	peak

Remark:
 Factor = Antenna Factor + Cable Loss – Pre-amplifier.
 No emission above 18GHz

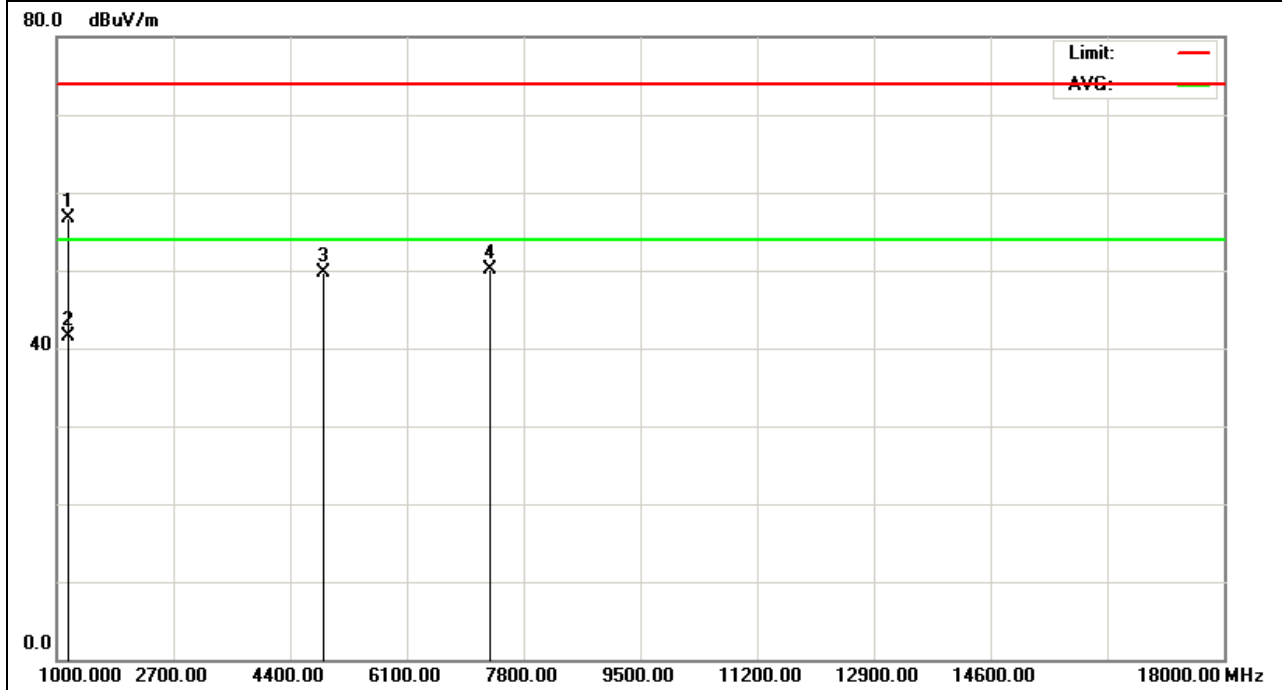

EUT :	38" sound bar 2.1 system with wireless subwoofer	Model Name :	S3821w-C0
Temperature :	20 °C	Relative Humidity :	48%
Pressure :	1010 hPa	Test Voltage :	AC 120V/60Hz
Test Mode :	TX 2441MHz – CH 39(2Mbps)	Polarization :	Vertical

Frequency (MHz)	Meter Reading (dBµV)	Factor (dB)	Emission Level (dBµV/m)	Limits (dBµV/m)	Margin (dB)	Detector Type
1170	76.45	-18.54	57.91	74	-16.09	peak
1170	58.39	-18.54	39.85	54	-14.15	AVG
4882	53	-3.68	49.32	74	-24.68	peak
7323	51.06	-0.82	50.24	74	-23.76	peak

Remark:
 Factor = Antenna Factor + Cable Loss – Pre-amplifier.
 No emission above 18GHz

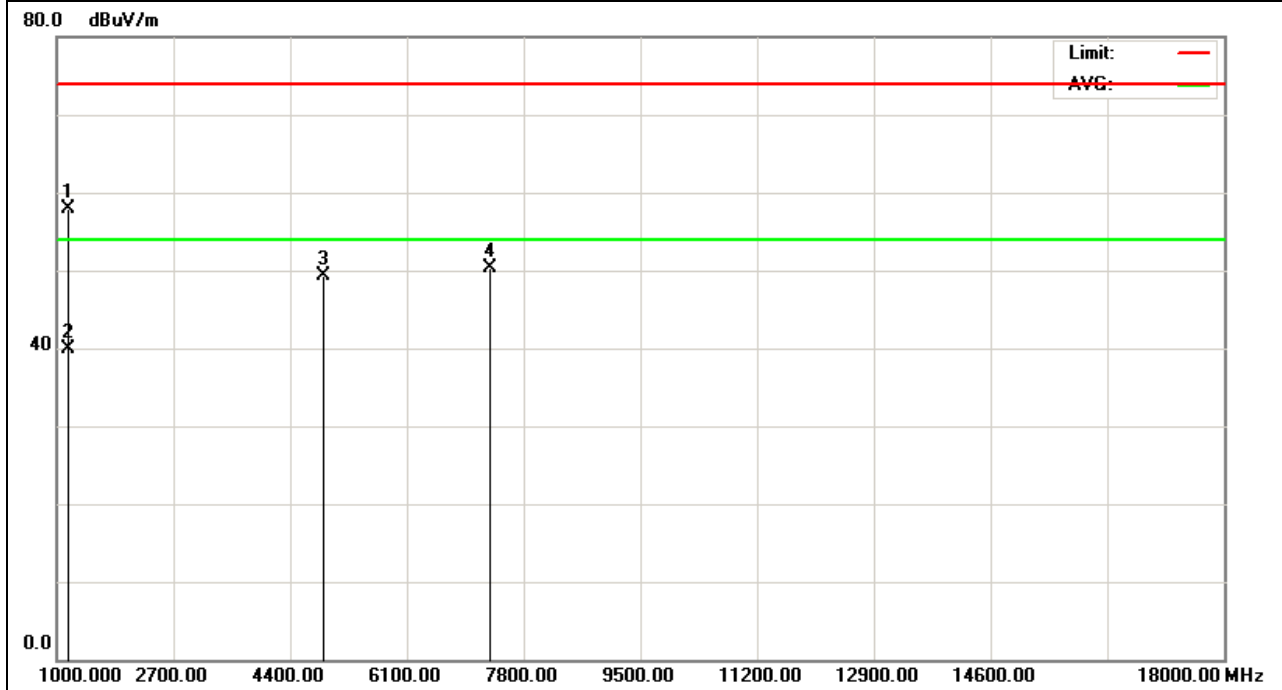

EUT :	38" sound bar 2.1 system with wireless subwoofer	Model Name :	S3821w-C0
Temperature :	20 °C	Relative Humidity :	48%
Pressure :	1010 hPa	Test Voltage :	AC 120V/60Hz
Test Mode :	TX 2480MHz – CH 78(2Mbps)	Polarization :	Horizontal

Frequency (MHz)	Meter Reading (dBµV)	Factor (dB)	Emission Level (dBµV/m)	Limits (dBµV/m)	Margin (dB)	Detector Type
1680	72.5	-15.74	56.76	74	-17.24	peak
1680	56.88	-15.74	41.14	54	-12.86	AVG
4960	52.77	-3.59	49.18	74	-24.82	peak
7440	50.49	-0.69	49.8	74	-24.2	peak

Remark:
 Factor = Antenna Factor + Cable Loss – Pre-amplifier.
 No emission above 18GHz

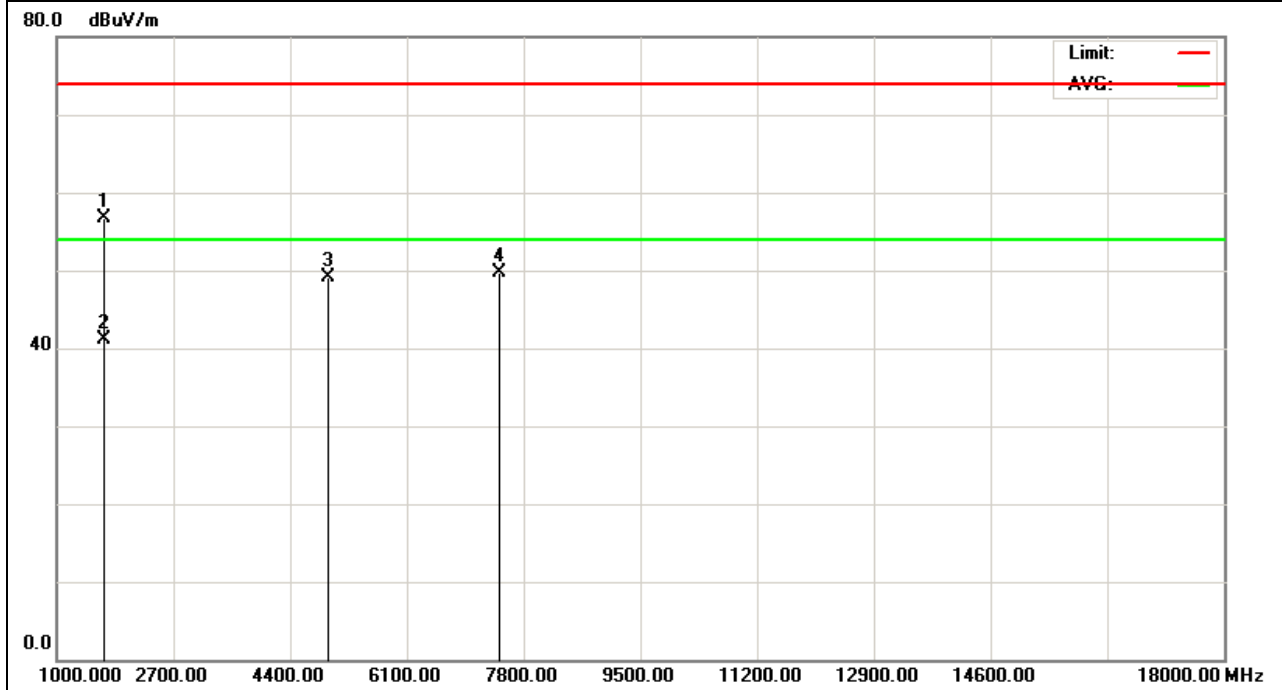

EUT :	38" sound bar 2.1 system with wireless subwoofer	Model Name :	S3821w-C0
Temperature :	20 °C	Relative Humidity :	48%
Pressure :	1010 hPa	Test Voltage :	AC 120V/60Hz
Test Mode :	TX 2480MHz – CH 78(2Mbps)	Polarization :	Vertical

Frequency (MHz)	Meter Reading (dBμV)	Factor (dB)	Emission Level (dBμV/m)	Limits (dBμV/m)	Margin (dB)	Detector Type
1170	79.4	-18.54	60.86	74	-13.14	peak
1170	59.56	-18.54	41.02	54	-12.98	AVG
4960	52.76	-3.59	49.17	74	-24.83	peak
7440	50.96	-0.69	50.27	74	-23.73	peak

Remark:
 Factor = Antenna Factor + Cable Loss – Pre-amplifier.
 No emission above 18GHz

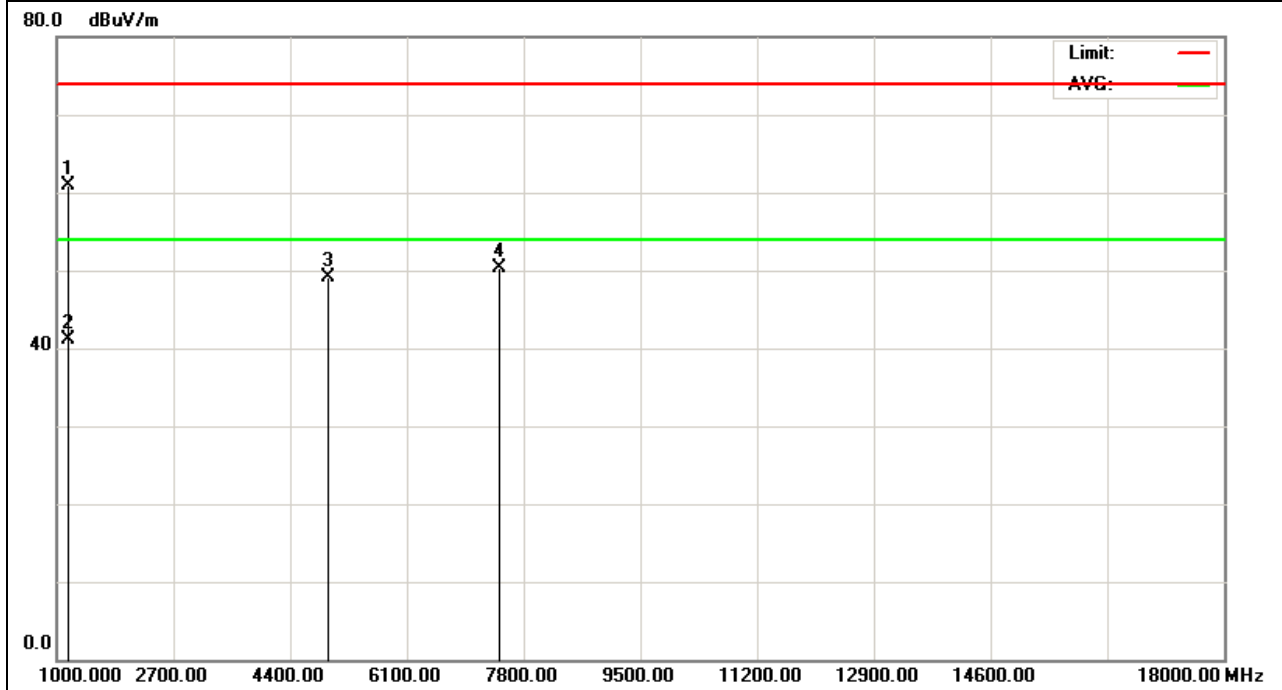

EUT :	38" sound bar 2.1 system with wireless subwoofer	Model Name :	S3821w-C0
Temperature :	20 °C	Relative Humidity :	48%
Pressure :	1010 hPa	Test Voltage :	AC 120V/60Hz
Test Mode :	TX 2402MHz – CH00 (3Mbps)	Polarization :	Horizontal

Frequency (MHz)	Meter Reading (dBμV)	Factor (dB)	Emission Level (dBμV/m)	Limits (dBμV/m)	Margin (dB)	Detector Type
1595	70.1	-16.43	53.67	74	-20.33	peak
4804	53.35	-3.64	49.71	74	-24.29	peak
7206	51.05	-0.95	50.1	74	-23.9	peak

Remark:
 Factor = Antenna Factor + Cable Loss – Pre-amplifier.
 No emission above 18GHz

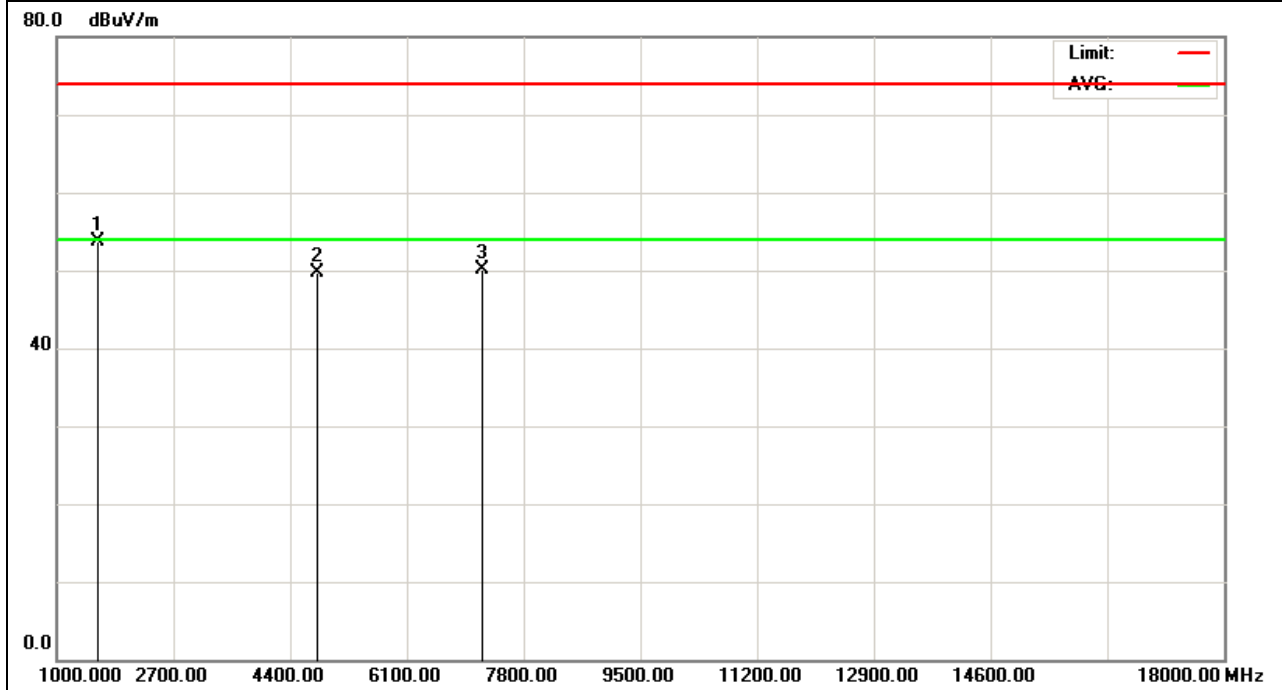

EUT :	38" sound bar 2.1 system with wireless subwoofer	Model Name :	S3821w-C0
Temperature :	20 °C	Relative Humidity :	48%
Pressure :	1010 hPa	Test Voltage :	AC 120V/60Hz
Test Mode :	TX 2402MHz – CH00 (3Mbps)	Polarization :	Vertical

Frequency (MHz)	Meter Reading (dBμV)	Factor (dB)	Emission Level (dBμV/m)	Limits (dBμV/m)	Margin (dB)	Detector Type
1170	71.67	-18.54	53.13	74	-20.87	peak
4804	54.33	-3.64	50.69	74	-23.31	peak
7206	51.07	-0.95	50.12	74	-23.88	peak

Remark:
 Factor = Antenna Factor + Cable Loss – Pre-amplifier.
 No emission above 18GHz

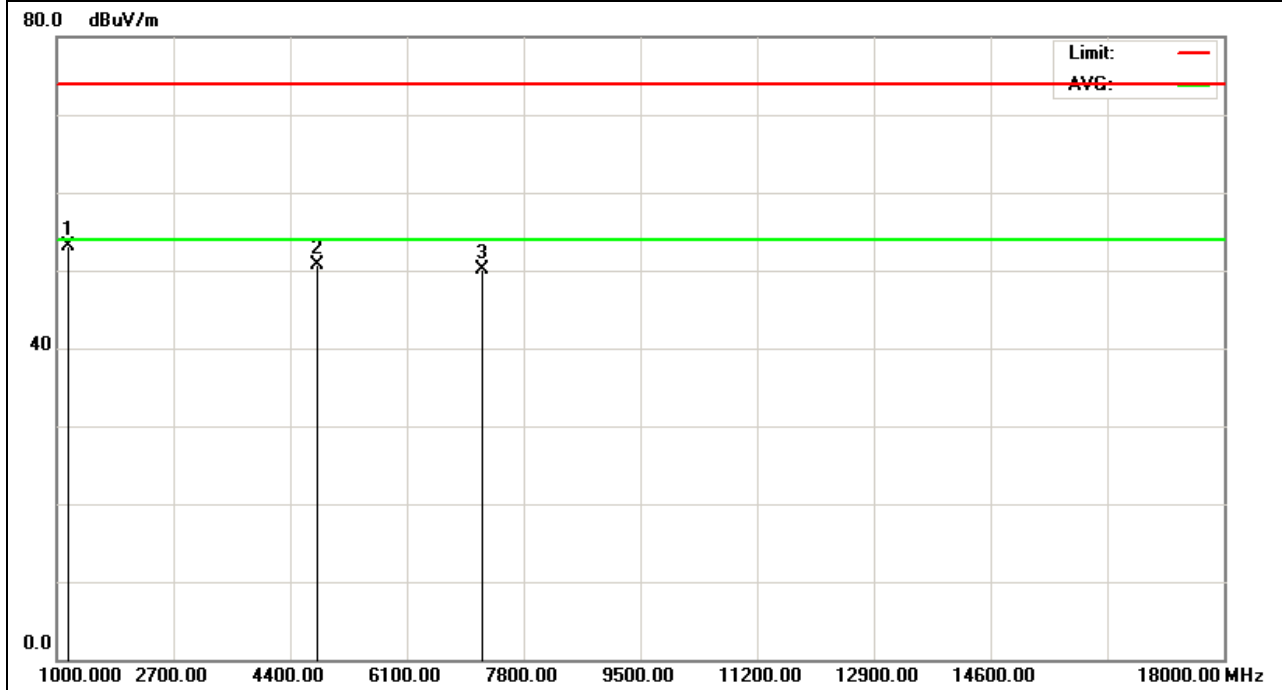

EUT :	38" sound bar 2.1 system with wireless subwoofer	Model Name :	S3821w-C0
Temperature :	20 °C	Relative Humidity :	48%
Pressure :	1010 hPa	Test Voltage :	AC 120V/60Hz
Test Mode :	TX 2441MHz – CH39(3Mbps)	Polarization :	Horizontal

Frequency (MHz)	Meter Reading (dBµV)	Factor (dB)	Emission Level (dBµV/m)	Limits (dBµV/m)	Margin (dB)	Detector Type
1170	74.97	-18.54	56.43	74	-17.57	peak
1170	58.24	-18.54	39.7	54	-14.3	AVG
4882	52.61	-3.68	48.93	74	-25.07	peak
7323	51.07	-0.82	50.25	74	-23.75	peak

Remark:
 Factor = Antenna Factor + Cable Loss – Pre-amplifier.
 No emission above 18GHz

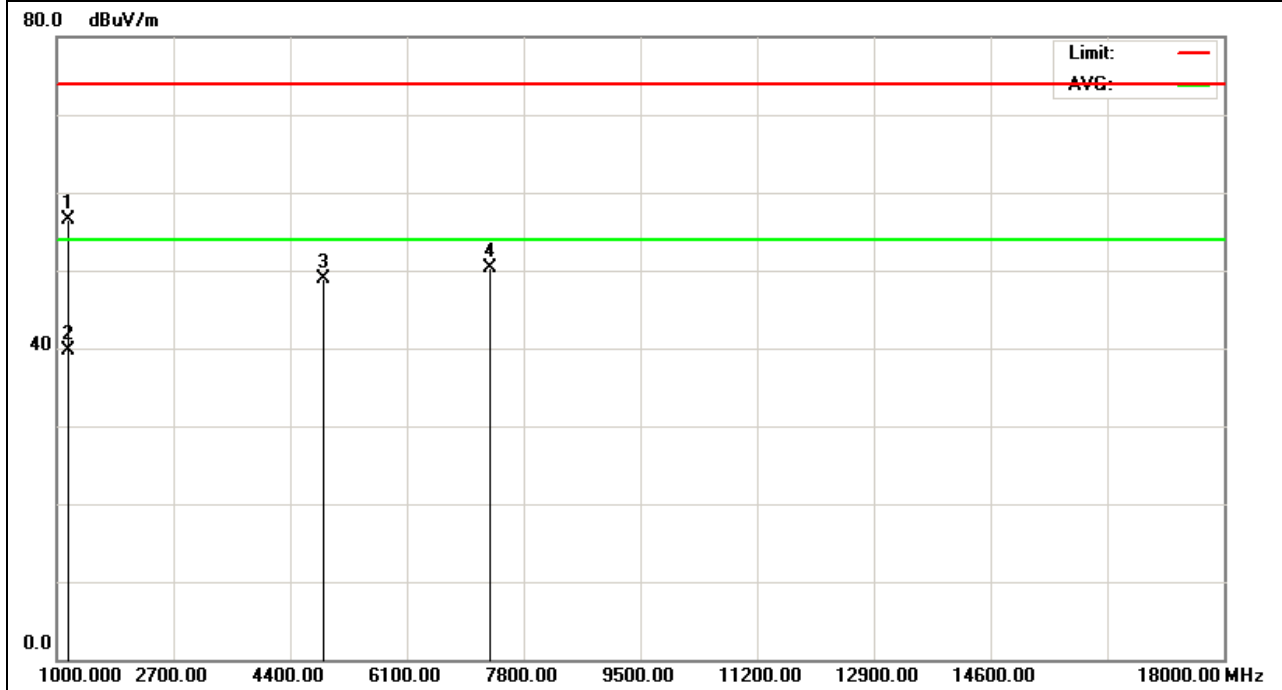

EUT :	38" sound bar 2.1 system with wireless subwoofer	Model Name :	S3821w-C0
Temperature :	20 °C	Relative Humidity :	48%
Pressure :	1010 hPa	Test Voltage :	AC 120V/60Hz
Test Mode :	TX 2441MHz – CH39 (3Mbps)	Polarization :	Vertical

Frequency (MHz)	Meter Reading (dBμV)	Factor (dB)	Emission Level (dBμV/m)	Limits (dBμV/m)	Margin (dB)	Detector Type
1637.5	59.49	-16.06	43.43	74	-30.57	peak
4882	50.28	-3.68	46.6	74	-27.4	peak
7323	49.94	-0.82	49.12	74	-24.88	peak

Remark:
 Factor = Antenna Factor + Cable Loss – Pre-amplifier.
 No emission above 18GHz

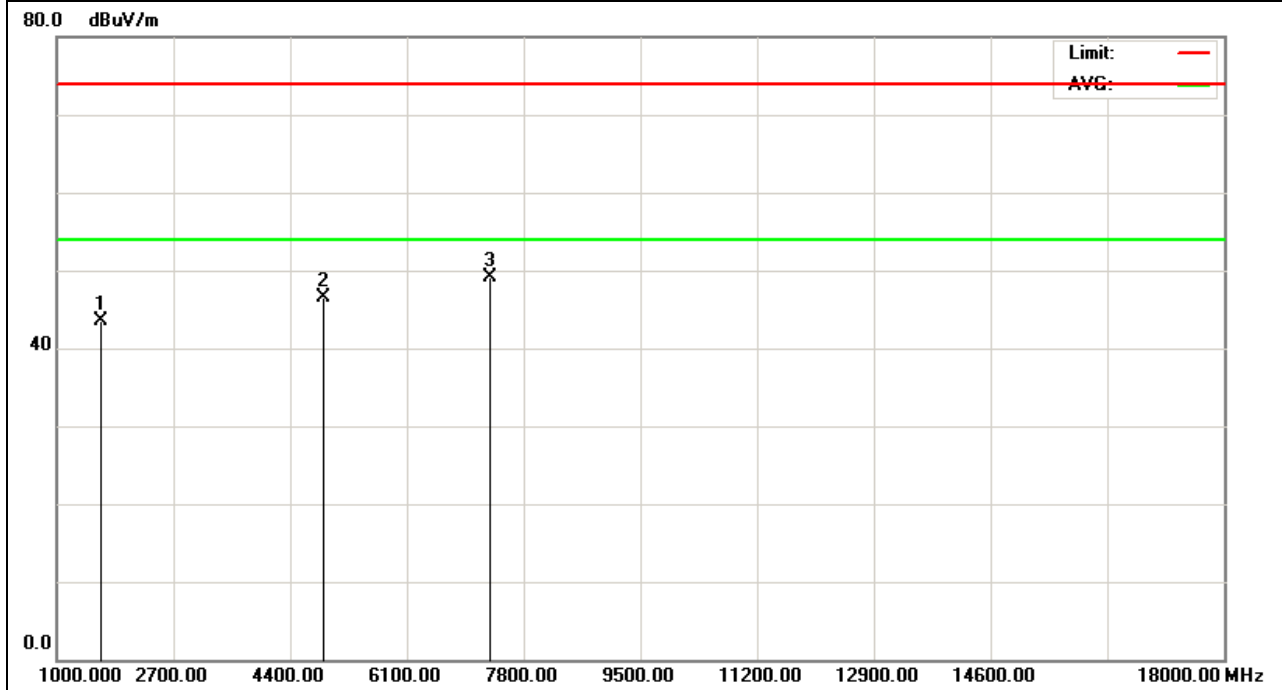

EUT :	38" sound bar 2.1 system with wireless subwoofer	Model Name :	S3821w-C0
Temperature :	20 °C	Relative Humidity :	48%
Pressure :	1010 hPa	Test Voltage :	AC 120V/60Hz
Test Mode :	TX 2480MHz – CH78 (3Mbps)	Polarization :	Horizontal

Frequency (MHz)	Meter Reading (dBμV)	Factor (dB)	Emission Level (dBμV/m)	Limits (dBμV/m)	Margin (dB)	Detector Type
1170	69.08	-18.54	50.54	74	-23.46	peak
4960	52.41	-3.59	48.82	74	-25.18	peak
7440	50.89	-0.69	50.2	74	-23.8	peak

Remark:
 Factor = Antenna Factor + Cable Loss – Pre-amplifier.
 No emission above 18GHz

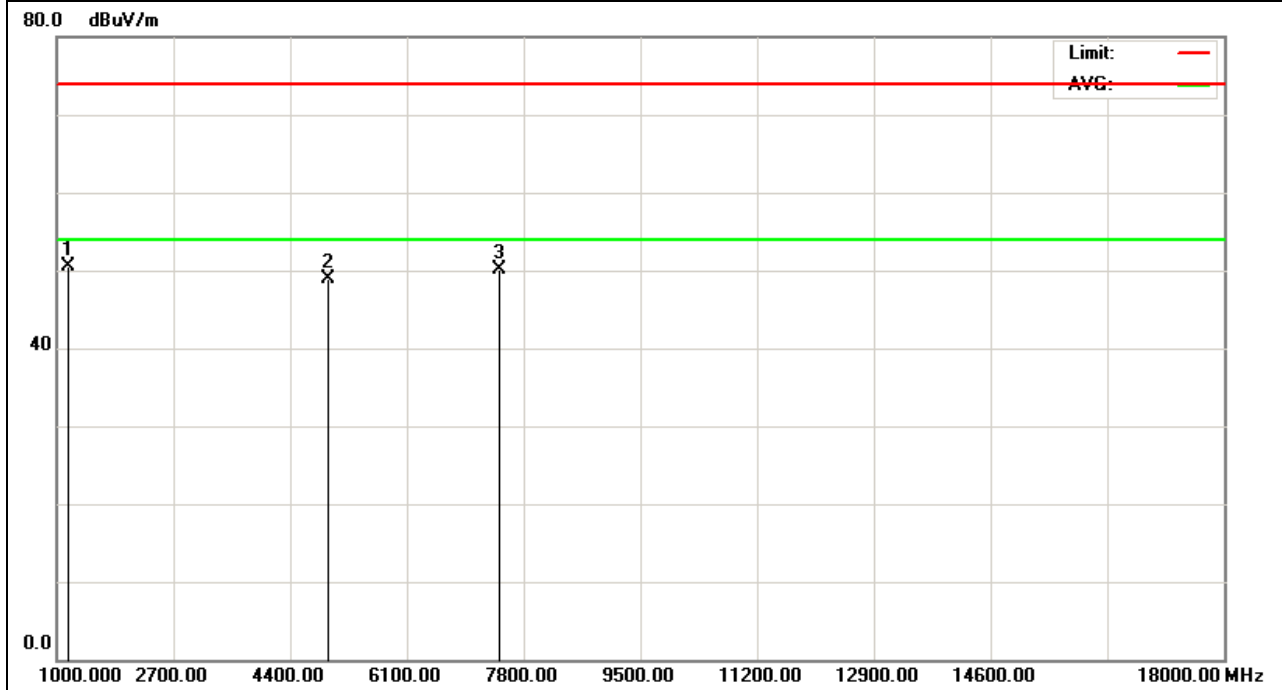

EUT :	38" sound bar 2.1 system with wireless subwoofer	Model Name :	S3821w-C0
Temperature :	20 °C	Relative Humidity :	48%
Pressure :	1010 hPa	Test Voltage :	AC 120V/60Hz
Test Mode :	TX 2480MHz – CH78 (3Mbps)	Polarization :	Vertical

Frequency (MHz)	Meter Reading (dBμV)	Factor (dB)	Emission Level (dBμV/m)	Limits (dBμV/m)	Margin (dB)	Detector Type
1170	72.39	-18.54	53.85	74	-20.15	peak
4960	57.99	-3.59	54.4	74	-19.6	peak
4960	41.87	-3.59	38.28	54	-15.72	AVG
7440	50.58	-0.69	49.89	74	-24.11	peak

Remark:
 Factor = Antenna Factor + Cable Loss – Pre-amplifier.
 No emission above 18GHz

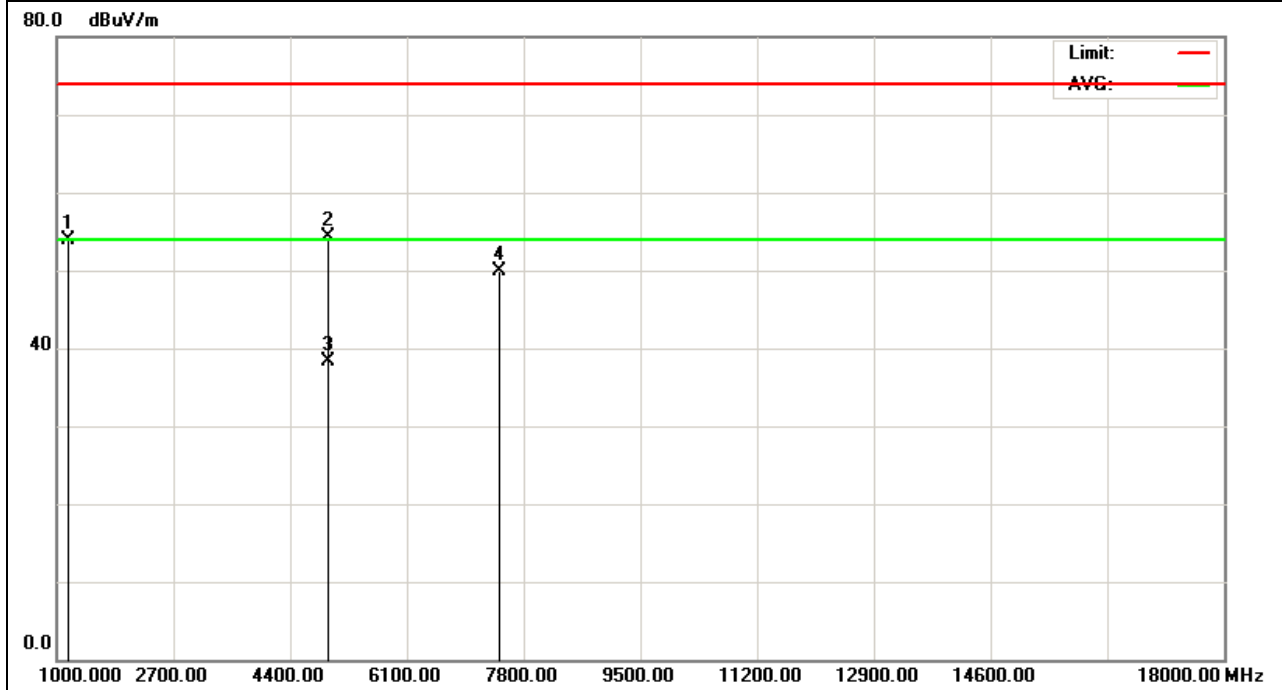

3.2.9 TEST RESULTS (RESTRICTED BANDS REQUIREMENTS)

EUT :	38" sound bar 2.1 system with wireless subwoofer	Model Name :	S3821w-C0
Temperature :	20 °C	Relative Humidity :	48%
Pressure :	1010 hPa	Test Voltage :	AC 120V/60Hz
Test Mode :	TX /2402MHz-1Mbps	Polarization :	Vertical

Frequency (MHz)	Meter Reading (dBμV)	Factor (dB)	Emission Level (dBμV/m)	Limits (dBμV/m)	Margin (dB)	Detector Type
2400.000	63.78	-12.99	50.79	74.00	-23.21	peak

Remark:

Factor = Antenna Factor + Cable Loss – Pre-amplifier.

Hopping enabled and disabled have evaluated, and the worst data was reported

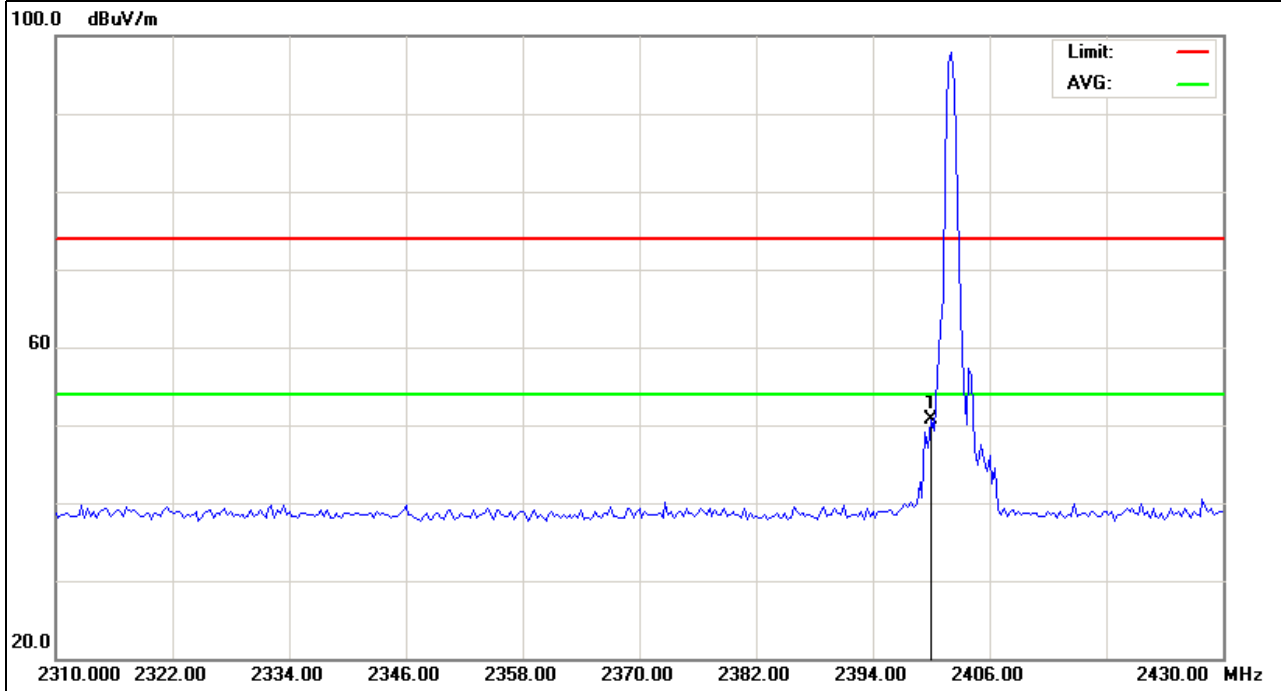

EUT :	38" sound bar 2.1 system with wireless subwoofer	Model Name :	S3821w-C0
Temperature :	20 °C	Relative Humidity :	48%
Pressure :	1010 hPa	Test Voltage :	AC 120V/60Hz
Test Mode :	TX /2402MHz-1Mbps	Polarization :	Horizontal

Frequency (MHz)	Meter Reading (dBμV)	Factor (dB)	Emission Level (dBμV/m)	Limits (dBμV/m)	Margin (dB)	Detector Type
2400.000	61.14	-12.99	48.15	74.00	-25.85	peak

Remark:

Factor = Antenna Factor + Cable Loss – Pre-amplifier.

Hopping enabled and disabled have evaluated, and the worst data was reported

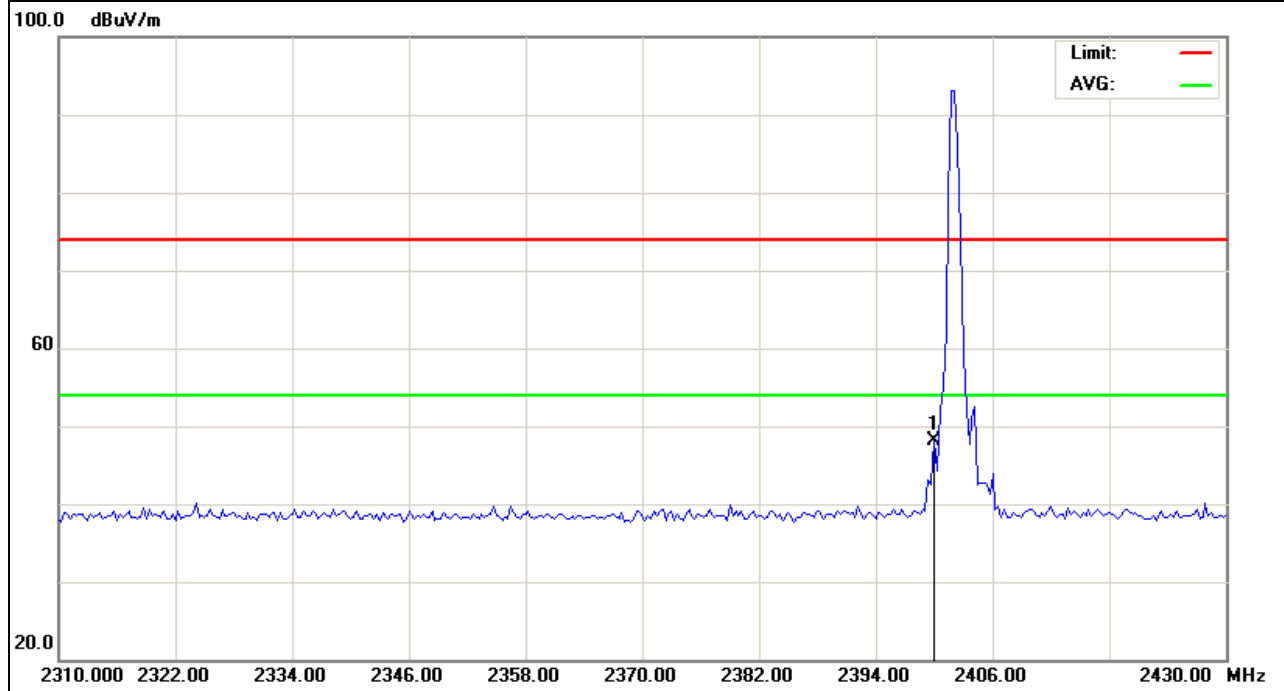

EUT :	38" sound bar 2.1 system with wireless subwoofer	Model Name :	S3821w-C0
Temperature :	20 °C	Relative Humidity :	48%
Pressure :	1010 hPa	Test Voltage :	AC 120V/60Hz
Test Mode :	TX /2480MHz-1Mbps	Polarization :	Vertical

Frequency (MHz)	Meter Reading (dBμV)	Factor (dB)	Emission Level (dBμV/m)	Limits (dBμV/m)	Margin (dB)	Detector Type
2483.500	52.26	-12.78	39.48	74.00	-34.52	peak

Remark:

Factor = Antenna Factor + Cable Loss – Pre-amplifier.

Hopping enabled and disabled have evaluated, and the worst data was reported

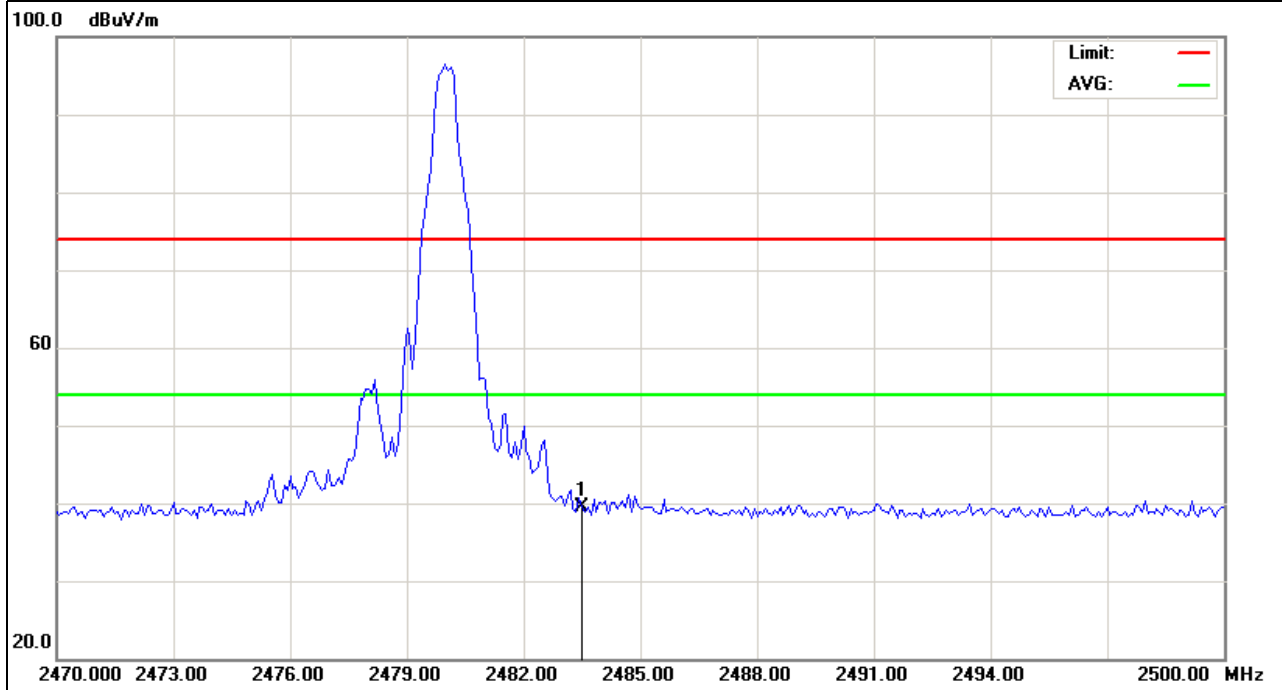

EUT :	38" sound bar 2.1 system with wireless subwoofer	Model Name :	S3821w-C0
Temperature :	20 °C	Relative Humidity :	48%
Pressure :	1010 hPa	Test Voltage :	AC 120V/60Hz
Test Mode :	TX /2480MHz-1Mbps	Polarization :	Horizontal

Frequency (MHz)	Meter Reading (dBμV)	Factor (dB)	Emission Level (dBμV/m)	Limits (dBμV/m)	Margin (dB)	Detector Type
2483.500	50.99	-12.78	38.21	74.00	-35.79	peak

Remark:

Factor = Antenna Factor + Cable Loss – Pre-amplifier.

Hopping enabled and disabled have evaluated, and the worst data was reported

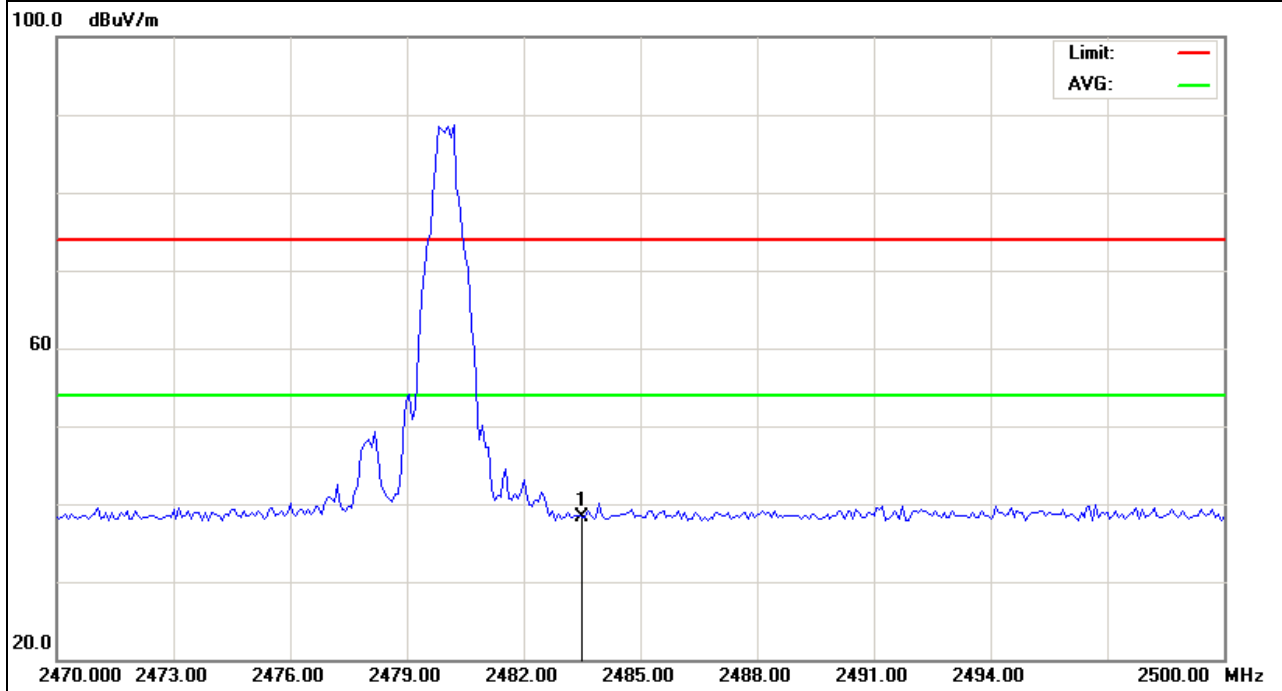

EUT :	38" sound bar 2.1 system with wireless subwoofer	Model Name :	S3821w-C0
Temperature :	20 °C	Relative Humidity :	48%
Pressure :	1010 hPa	Test Voltage :	AC 120V/60Hz
Test Mode :	TX /2402MHz-2Mbps	Polarization :	Vertical

Frequency (MHz)	Meter Reading (dBμV)	Factor (dB)	Emission Level (dBμV/m)	Limits (dBμV/m)	Margin (dB)	Detector Type
2400.000	68.03	-12.99	55.04	74.00	-18.96	peak
2400.000	54.34	-12.99	41.35	54.00	-12.65	AVG

Remark:

Factor = Antenna Factor + Cable Loss – Pre-amplifier.

Hopping enabled and disabled have evaluated, and the worst data was reported

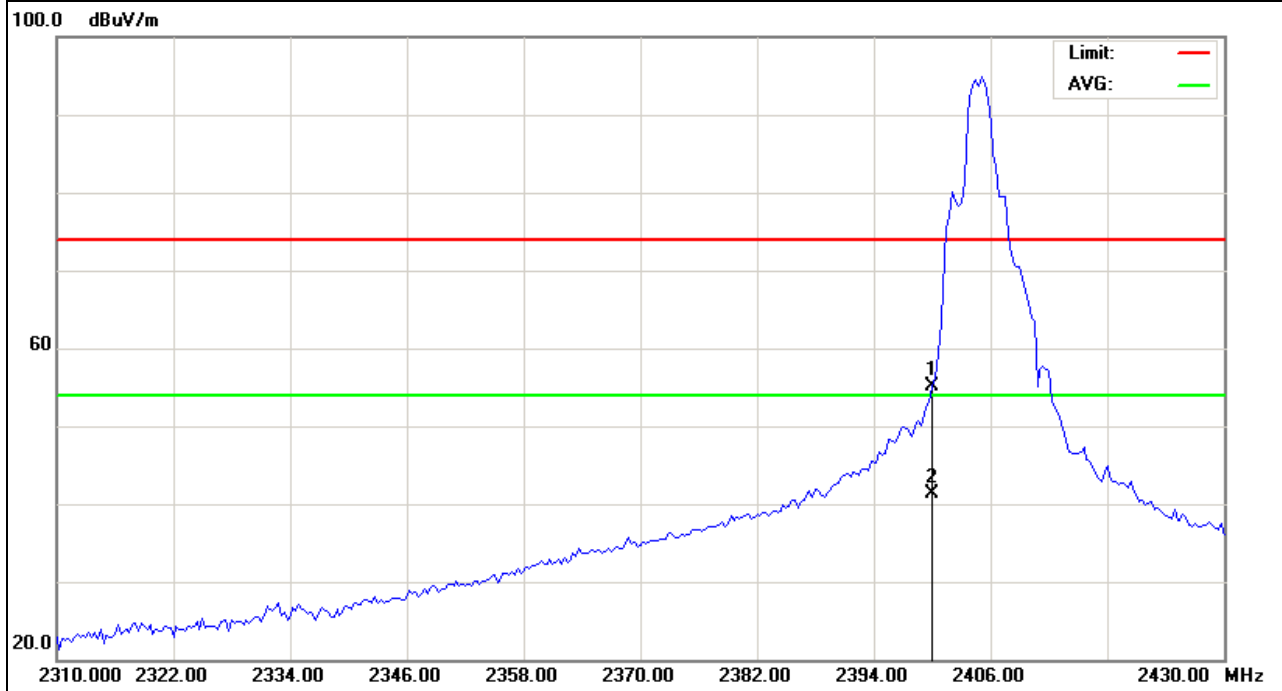

EUT :	38" sound bar 2.1 system with wireless subwoofer	Model Name :	S3821w-C0
Temperature :	20 °C	Relative Humidity :	48%
Pressure :	1010 hPa	Test Voltage :	AC 120V/60Hz
Test Mode :	TX /2402MHz-2Mbps	Polarization :	Horizontal

Frequency (MHz)	Meter Reading (dBμV)	Factor (dB)	Emission Level (dBμV/m)	Limits (dBμV/m)	Margin (dB)	Detector Type
2400.000	63.57	-12.99	50.58	74.00	-23.42	peak

Remark:

Factor = Antenna Factor + Cable Loss – Pre-amplifier.

Hopping enabled and disabled have evaluated, and the worst data was reported

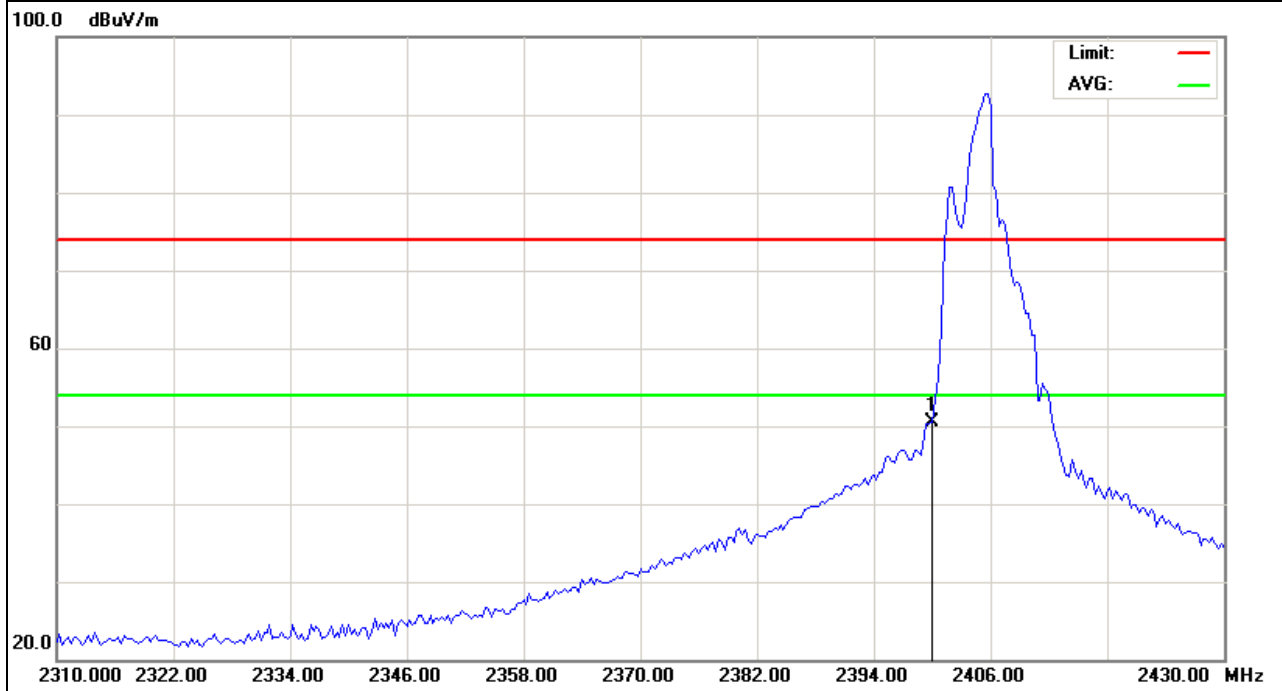

EUT :	38" sound bar 2.1 system with wireless subwoofer	Model Name :	S3821w-C0
Temperature :	20 °C	Relative Humidity :	48%
Pressure :	1010 hPa	Test Voltage :	AC 120V/60Hz
Test Mode :	TX /2480MHz-2Mbps	Polarization :	Vertical

Frequency (MHz)	Meter Reading (dBμV)	Factor (dB)	Emission Level (dBμV/m)	Limits (dBμV/m)	Margin (dB)	Detector Type
2483.500	36.16	-12.78	23.38	74.00	-50.62	peak

Remark:

Factor = Antenna Factor + Cable Loss – Pre-amplifier.

Hopping enabled and disabled have evaluated,and the worrest data was reported

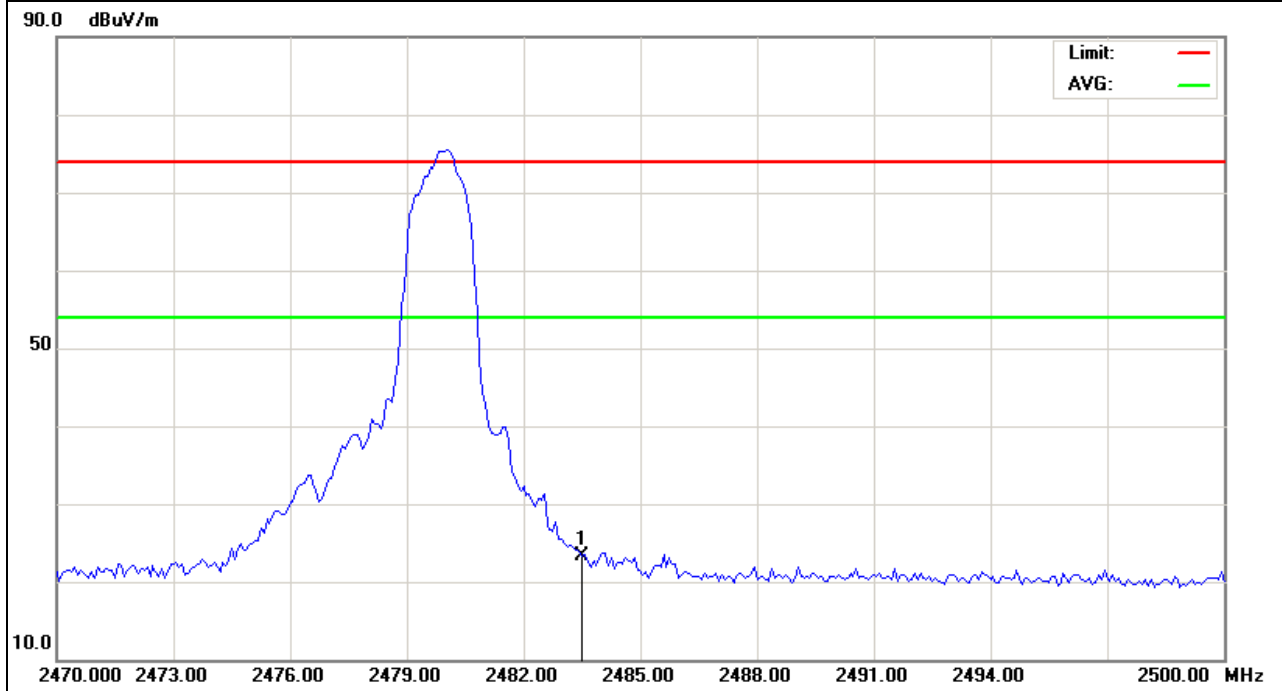

EUT :	38" sound bar 2.1 system with wireless subwoofer	Model Name :	S3821w-C0
Temperature :	20 °C	Relative Humidity :	48%
Pressure :	1010 hPa	Test Voltage :	AC 120V/60Hz
Test Mode :	TX /2480MHz-2Mbps	Polarization :	Horizontal

Frequency (MHz)	Meter Reading (dBμV)	Factor (dB)	Emission Level (dBμV/m)	Limits (dBμV/m)	Margin (dB)	Detector Type
2483.500	53.21	-12.78	40.43	74.00	-33.57	peak

Remark:

Factor = Antenna Factor + Cable Loss – Pre-amplifier.

Hopping enabled and disabled have evaluated, and the worst data was reported

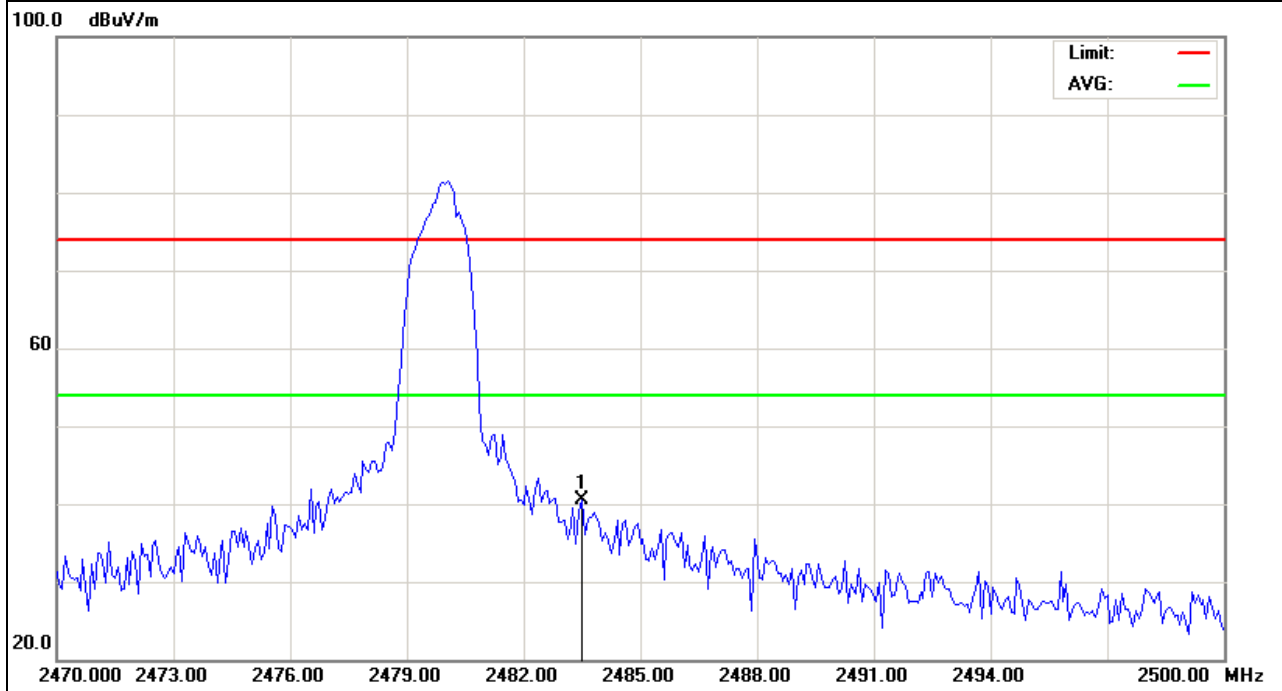

EUT :	38" sound bar 2.1 system with wireless subwoofer	Model Name :	S3821w-C0
Temperature :	20 °C	Relative Humidity :	48%
Pressure :	1010 hPa	Test Voltage :	AC 120V/60Hz
Test Mode :	TX /2402MHz-3Mbps	Polarization :	Vertical

Frequency (MHz)	Meter Reading (dBμV)	Factor (dB)	Emission Level (dBμV/m)	Limits (dBμV/m)	Margin (dB)	Detector Type
2400.000	66.96	-12.99	53.97	74.00	-20.03	peak

Remark:

Factor = Antenna Factor + Cable Loss – Pre-amplifier.

Hopping enabled and disabled have evaluated,and the worrest data was reported

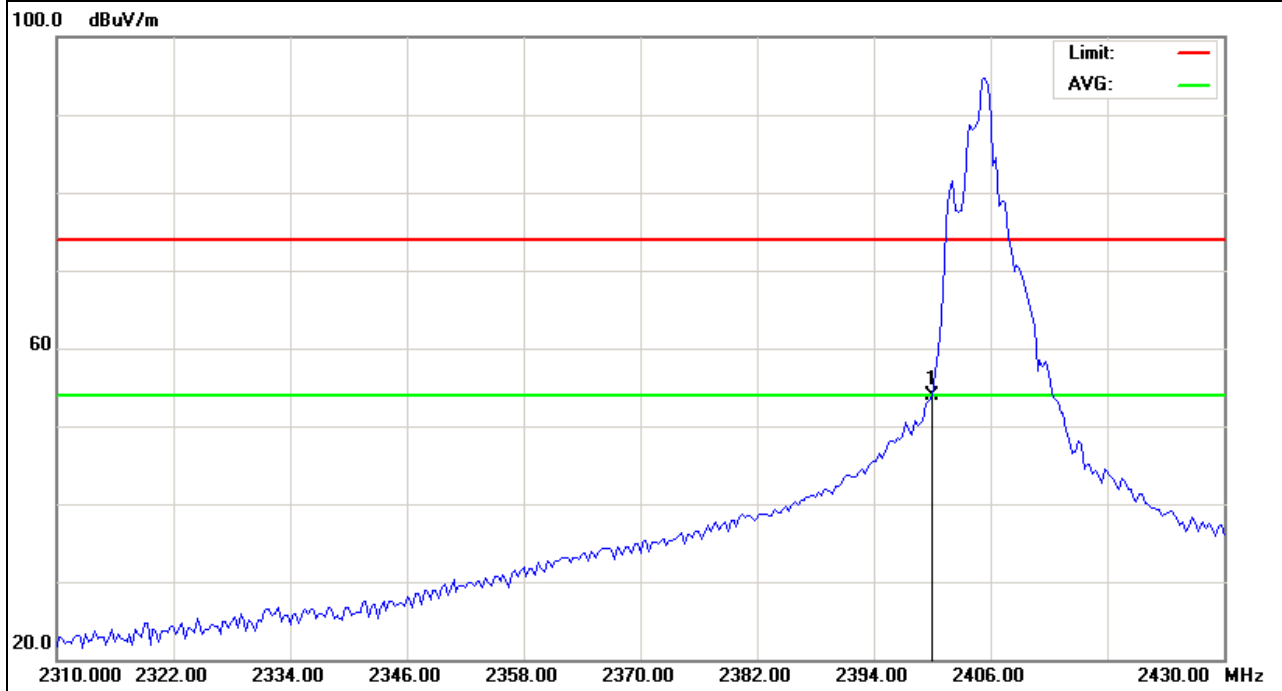

EUT :	38" sound bar 2.1 system with wireless subwoofer	Model Name :	S3821w-C0
Temperature :	20 °C	Relative Humidity :	48%
Pressure :	1010 hPa	Test Voltage :	AC 120V/60Hz
Test Mode :	TX /2402MHz-3Mbps	Polarization :	Horizontal

Frequency (MHz)	Meter Reading (dBμV)	Factor (dB)	Emission Level (dBμV/m)	Limits (dBμV/m)	Margin (dB)	Detector Type
2400.000	57.32	-12.99	44.33	74.00	-29.67	peak

Remark:

Factor = Antenna Factor + Cable Loss – Pre-amplifier.

Hopping enabled and disabled have evaluated, and the worst data was reported

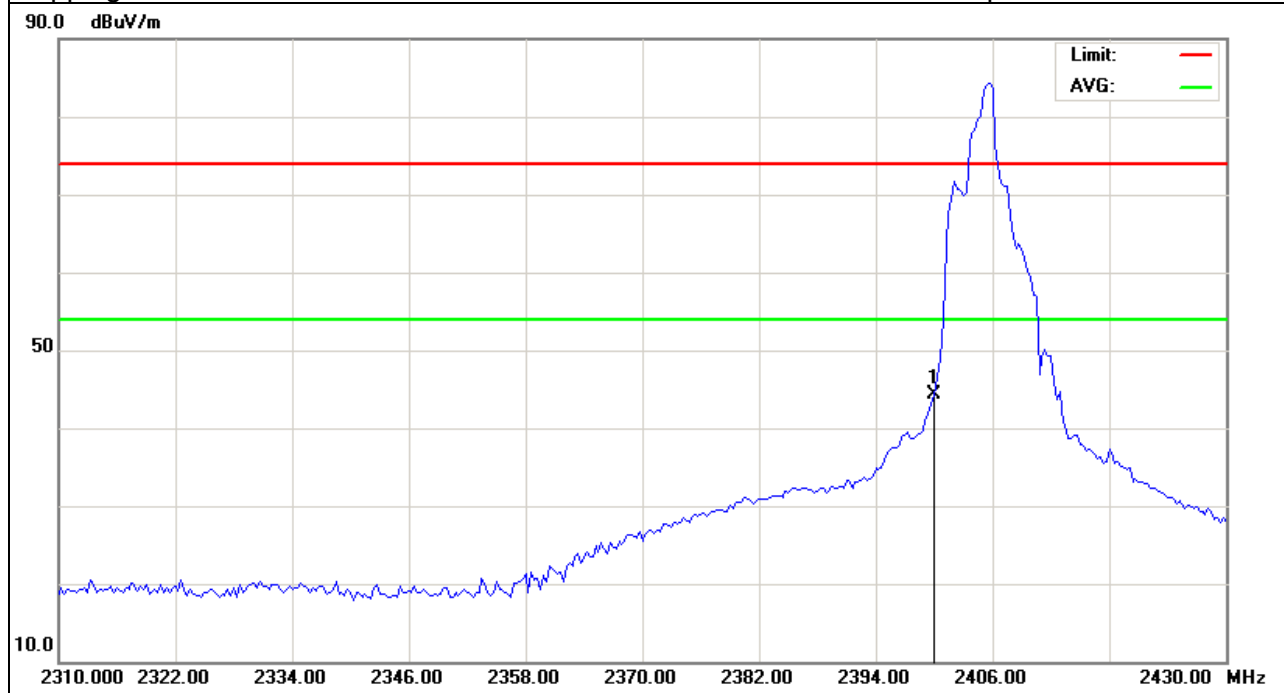

EUT :	38" sound bar 2.1 system with wireless subwoofer	Model Name :	S3821w-C0
Temperature :	20 °C	Relative Humidity :	48%
Pressure :	1010 hPa	Test Voltage :	AC 120V/60Hz
Test Mode :	TX /2480MHz-3Mbps	Polarization :	Vertical

Frequency (MHz)	Meter Reading (dBμV)	Factor (dB)	Emission Level (dBμV/m)	Limits (dBμV/m)	Margin (dB)	Detector Type
2483.500	53.08	-12.78	40.30	74.00	-33.70	peak

Remark:

Factor = Antenna Factor + Cable Loss – Pre-amplifier.

Hopping enabled and disabled have evaluated, and the worst data was reported

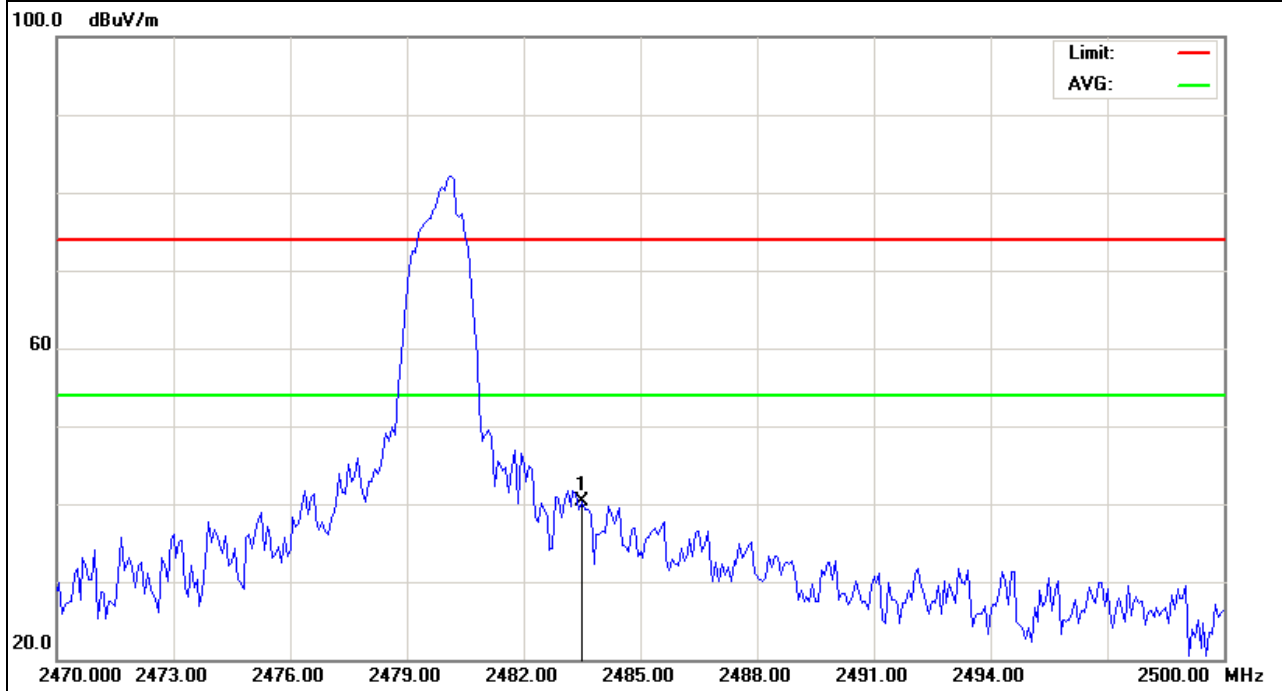

EUT :	38" sound bar 2.1 system with wireless subwoofer	Model Name :	S3821w-C0
Temperature :	20 °C	Relative Humidity :	48%
Pressure :	1010 hPa	Test Voltage :	AC 120V/60Hz
Test Mode :	TX /2480MHz-3Mbps	Polarization :	Horizontal

Frequency (MHz)	Meter Reading (dBμV)	Factor (dB)	Emission Level (dBμV/m)	Limits (dBμV/m)	Margin (dB)	Detector Type
2483.500	37.24	-12.78	24.46	74.00	-49.54	peak

Remark:
 Factor = Antenna Factor + Cable Loss – Pre-amplifier.
 Hopping enabled and disabled have evaluated,and the worrest data was reported

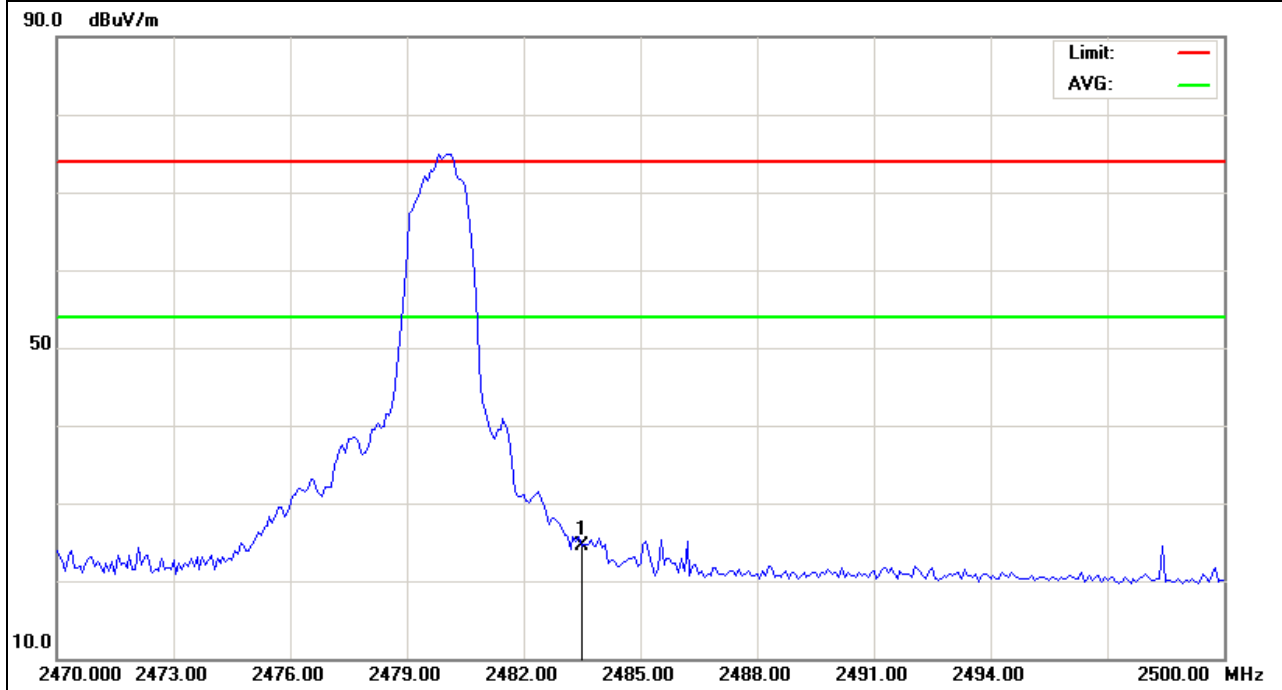

4. NUMBER OF HOPPING CHANNEL

4.1 APPLIED PROCEDURES / LIMIT

FCC Part15 (15.247) , Subpart C				
Section	Test Item	Limit	Frequency Range (MHz)	Result
15.247 (a)(1)(iii)	Number of Hopping Channel	≥15	2400-2483.5	PASS

Spectrum Parameters	Setting
Attenuation	Auto
Span Frequency	= the frequency band of operation
RB	RBW ≥ 1% of the span
VB	VBW ≥ RBW
Detector	Peak
Trace	Max Hold
Sweep Time	Auto

4.1.1 TEST PROCEDURE

- a. The EUT was directly connected to the spectrum analyzer and antenna output port as show in the block diagram below,
- b. Spectrum Setting : RBW= 1MHz, VBW=1MHz, Sweep time = Auto.

4.1.2 DEVIATION FROM STANDARD

No deviation.

4.1.3 TEST SETUP

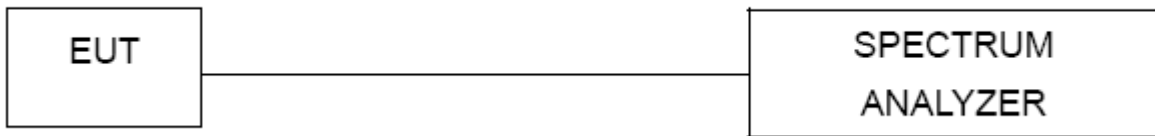

4.1.4 EUT OPERATION CONDITIONS

The EUT tested system was configured as the statements of 2.4 Unless otherwise a special operating condition is specified in the follows during the testing.

4.1.5 TEST RESULTS

EUT :	38" sound bar 2.1 system with wireless subwoofer	Model Name :	S3821w-C0
Temperature :	25 °C	Relative Humidity :	60%
Pressure :	1015 hPa	Test Voltage :	AC 120V/60Hz
Test Mode :	Hopping Mode		

Number of Hopping Channel	79
---------------------------	----

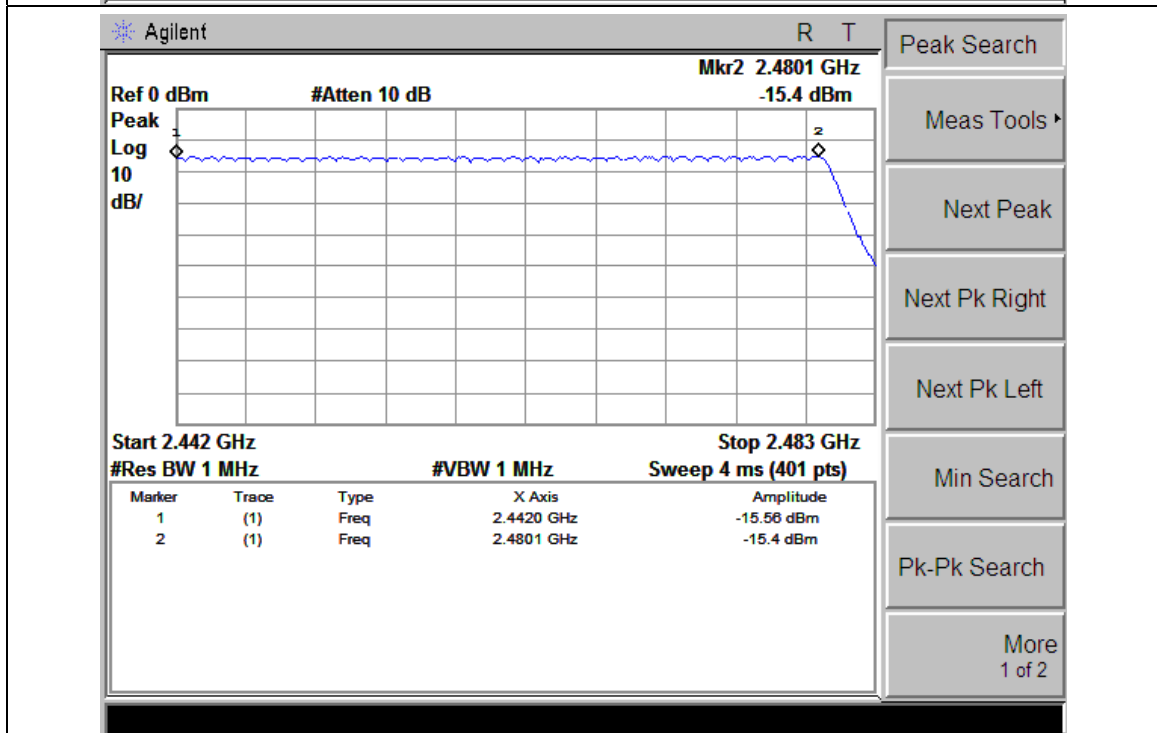
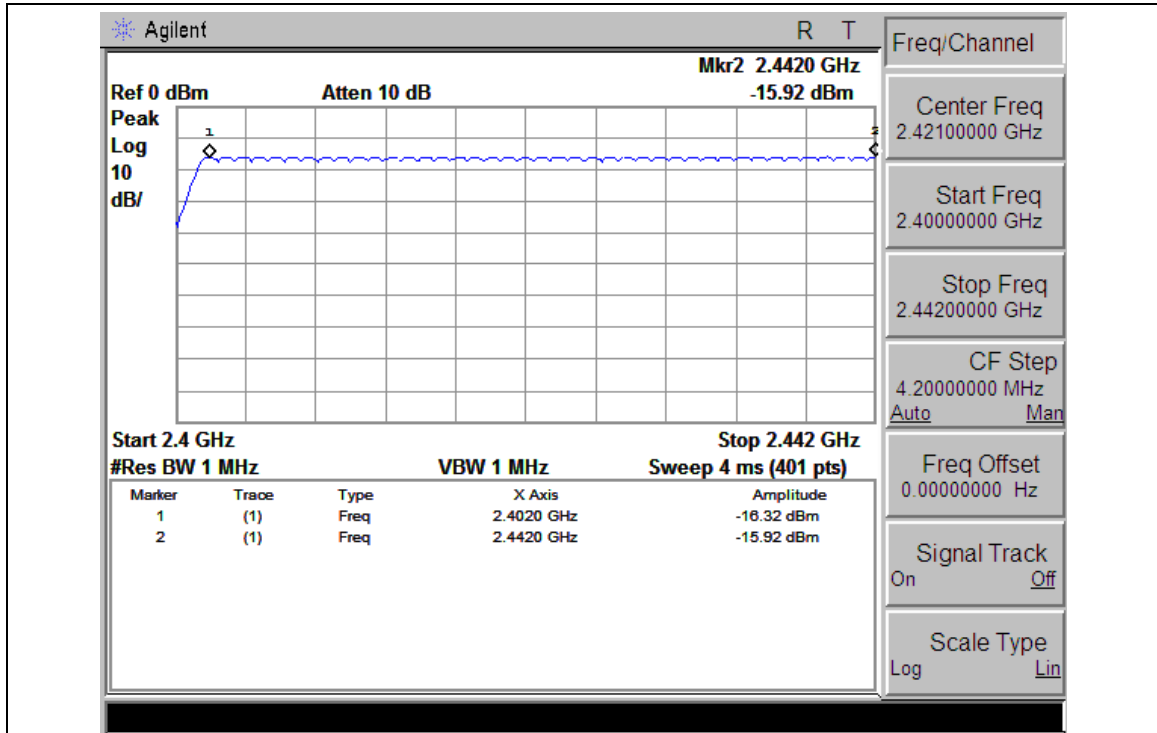

5. AVERAGE TIME OF OCCUPANCY

5.1 APPLIED PROCEDURES / LIMIT

FCC Part15 (15.247) , Subpart C				
Section	Test Item	Limit	Frequency Range (MHz)	Result
15.247 (a)(1)(iii)	Average Time of Occupancy	0.4sec	2400-2483.5	PASS

5.1.1 TEST PROCEDURE

- a. The transmitter output (antenna port) was connected to the spectrum analyzer
- b. Set RBW of spectrum analyzer to 1MHz and VBW to 1MHz.
- c. Use a video trigger with the trigger level set to enable triggering only on full pulses.
- d. Sweep Time is more than once pulse time.
- e. Set the center frequency on any frequency would be measure and set the frequency span to zero span.
- f. Measure the maximum time duration of one single pulse.
- g. Set the EUT for DH5, DH3 and DH1 packet transmitting.
- h. Measure the maximum time duration of one single pulse.
- i. A Period Time = (channel number)*0.4
 - DH1 Time Slot: Reading * (1600/2)*31.6/(channel number)
 - DH3 Time Slot: Reading * (1600/4)*31.6/(channel number)
 - DH5 Time Slot: Reading * (1600/6)*31.6/(channel number)

5.1.2 DEVIATION FROM STANDARD

No deviation.

5.1.3 TEST SETUP

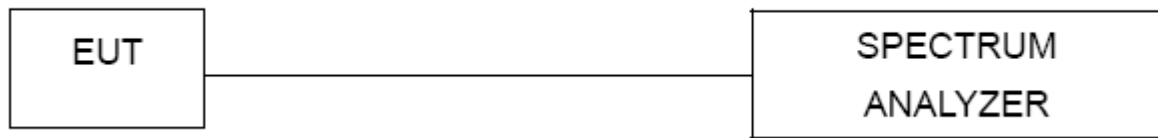

5.1.4 EUT OPERATION CONDITIONS

The EUT tested system was configured as the statements of 2.4 Unless otherwise a special operating condition is specified in the follows during the testing.

5.1.5 TEST RESULTS

EUT :	38" sound bar 2.1 system with wireless subwoofer	Model Name :	S3821w-C0
Temperature :	25 °C	Relative Humidity :	60%
Pressure :	1012 hPa	Test Voltage :	AC 120V/60Hz
Test Mode :	CH00-DH5 (1M/2M/3Mbps Mode)		

Data Packet	Frequency	Pulse Duration (ms)	Dwell Time (s)	Limits (s)
DH5	2441MHz	3.06	0.33	0.40
2DH5	2441MHz	3.09	0.33	0.40
3DH5	2441MHz	3.11	0.33	0.40

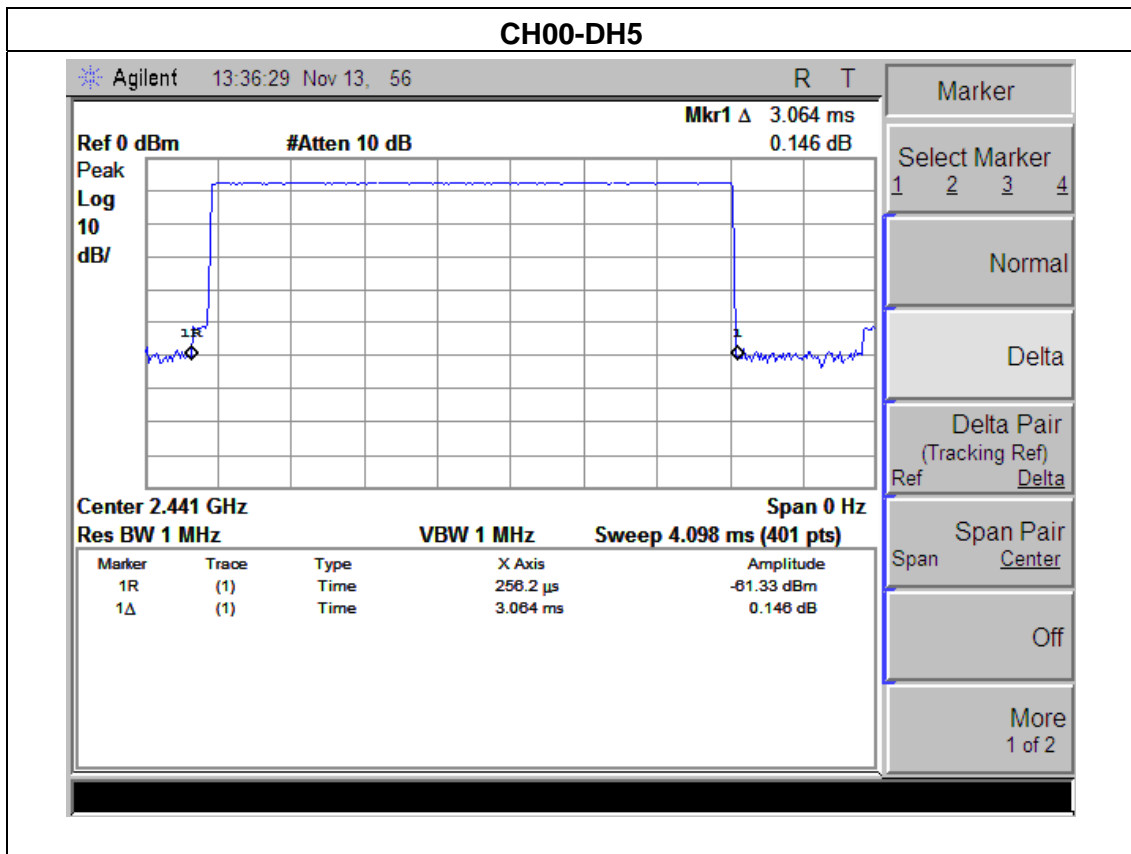

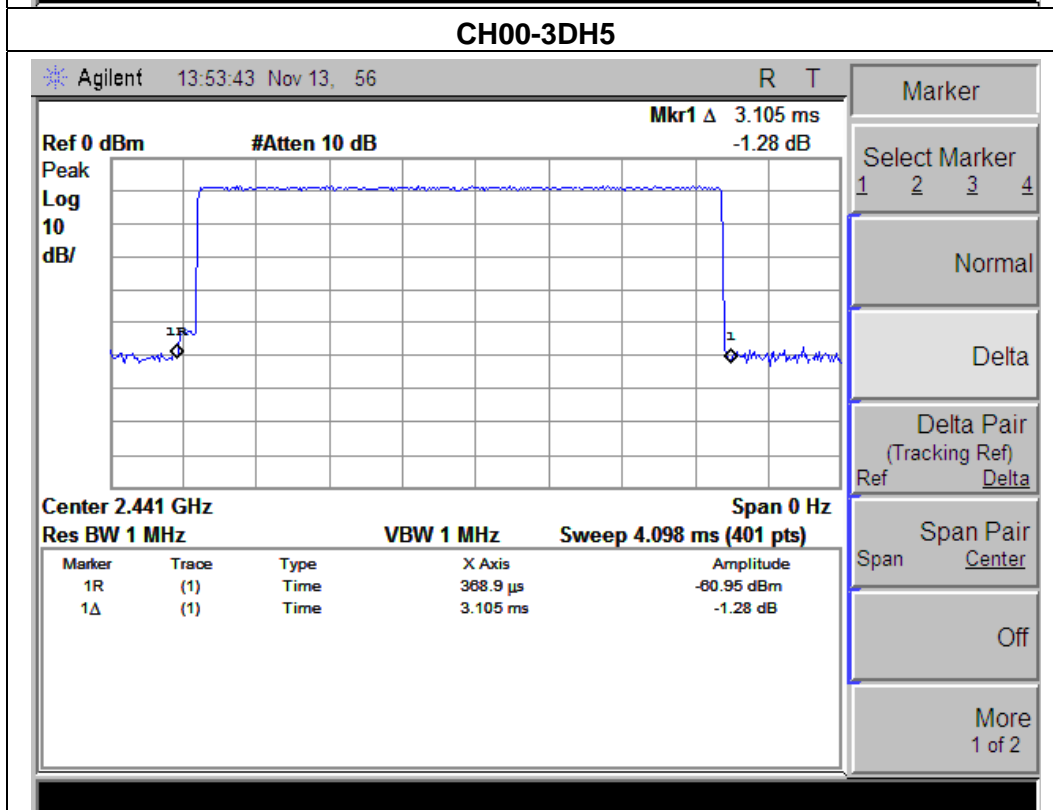
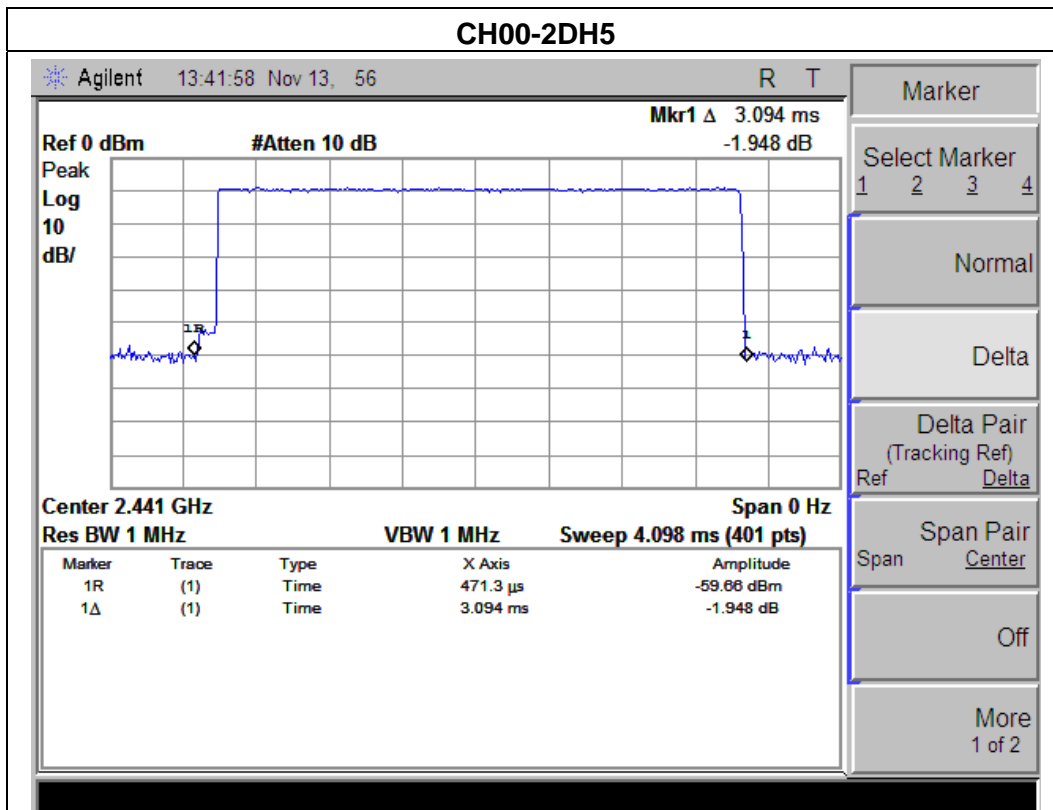

NOTE : The dwell time is showed the maximum data of all data(DH1,2DH1,3DH1, DH3,2DH3,3DH3, DH5,2DH5,3DH5), (DH5,2DH5,3DH5) of mode have the maximum dwell time.

6. HOPPING CHANNEL SEPARATION MEASUREMENT

6.1 APPLIED PROCEDURES / LIMIT

Frequency hopping systems operating in the 2400-2483.5 MHz band may have hopping channel carrier frequencies that are separated by 25 kHz or two-thirds of the 20 dB bandwidth of the hopping channel, whichever is greater.

Spectrum Parameter	Setting
Attenuation	Auto
Span Frequency	wide enough to capture the peaks of two adjacent channels
RB	≥ 1% of the span
VB	≥ RBW
Detector	Peak
Trace	Max Hold
Sweep Time	Auto

6.1.1 TEST PROCEDURE

- a. The transmitter output (antenna port) was connected to the spectrum analyser in peak hold mode.
- b. The resolution bandwidth of 100 kHz and the video bandwidth of 100 kHz were utilised for channel separation measurement.

6.1.2 DEVIATION FROM STANDARD

No deviation.

6.1.3 TEST SETUP

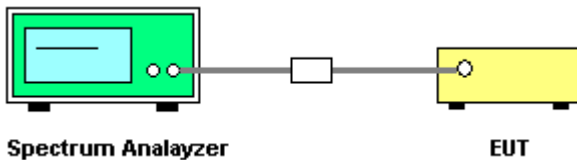

6.1.4 EUT OPERATION CONDITIONS

The EUT was programmed to be in continuously transmitting mode.

6.1.5 TEST RESULTS

EUT :	38" sound bar 2.1 system with wireless subwoofer	Model Name :	S3821w-C0
Temperature :	25 °C	Relative Humidity :	60%
Pressure :	1012 hPa	Test Voltage :	AC 120V/60Hz
Test Mode :	CH00 / CH39 /CH78 (1Mbps Mode)		

Frequency	Ch. Separation (MHz)	Result
2402 MHz	0.99	Complies
2441 MHz	-1.00	Complies
2480 MHz	1.00	Complies

Ch. Separation Limits: >20dB bandwidth

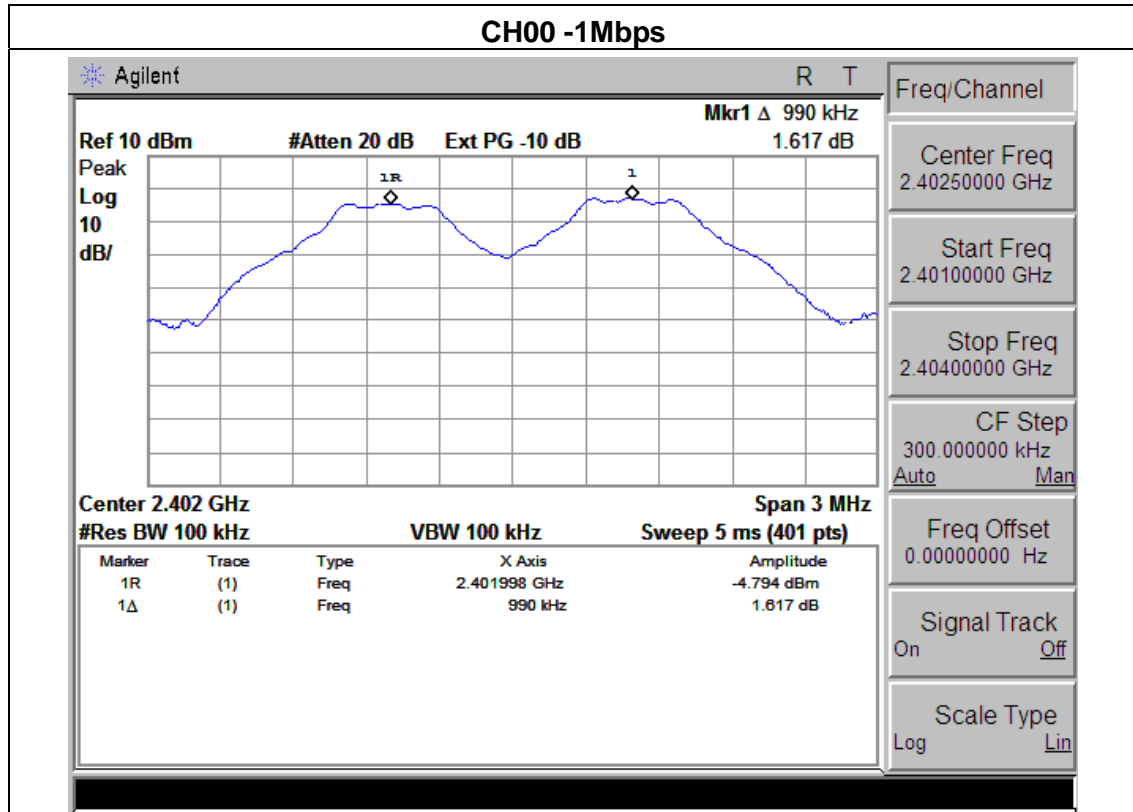

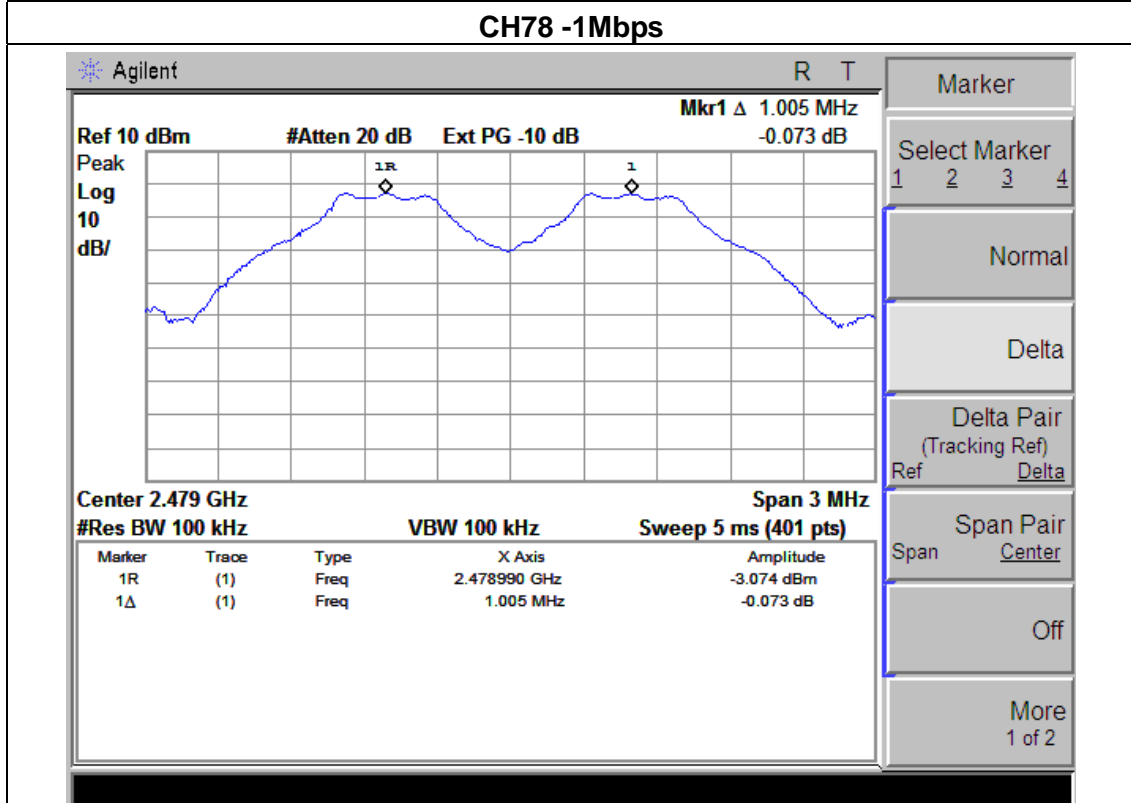
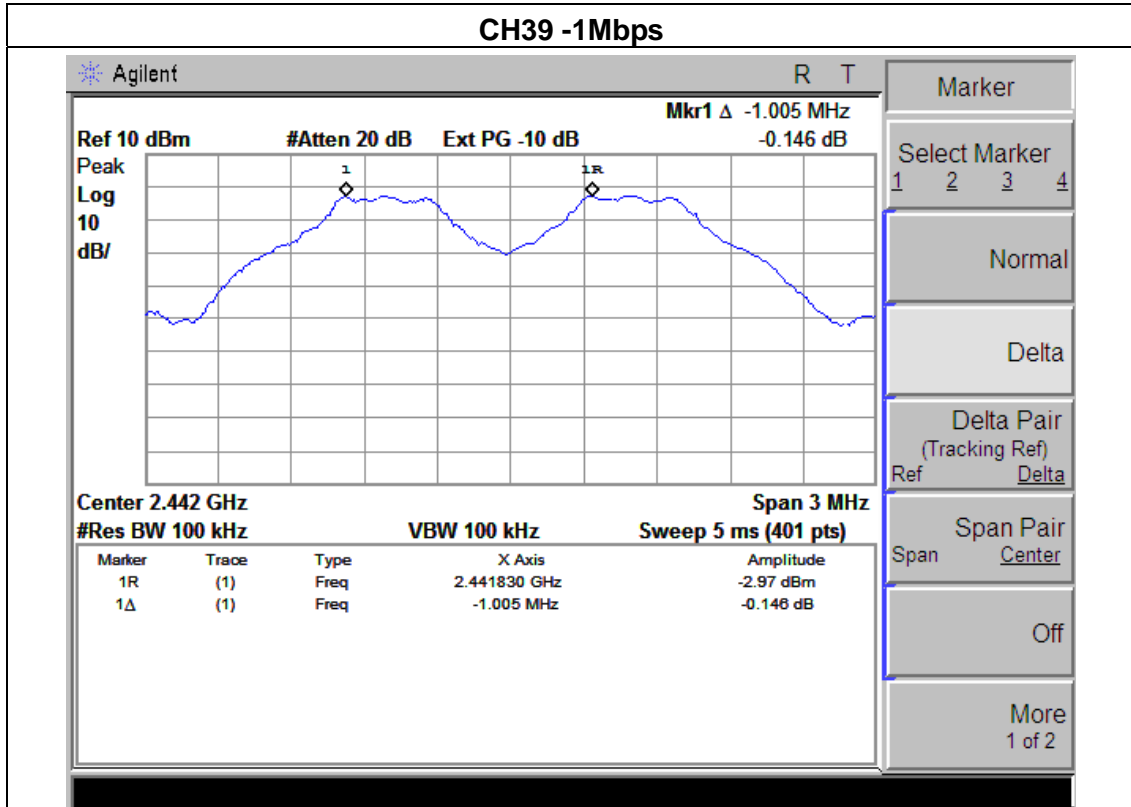

EUT :	38" sound bar 2.1 system with wireless subwoofer	Model Name :	S3821w-C0
Temperature :	25 °C	Relative Humidity :	60%
Pressure :	1012 hPa	Test Voltage :	AC 120V/60Hz
Test Mode :	CH00 / CH39 /CH78 (2Mbps Mode)		

Frequency	Ch. Separation (MHz)	Result
2402 MHz	1.01	Complies
2441 MHz	1.01	Complies
2480 MHz	1.04	Complies

Ch. Separation Limits: >2/3 of 20dB bandwidth

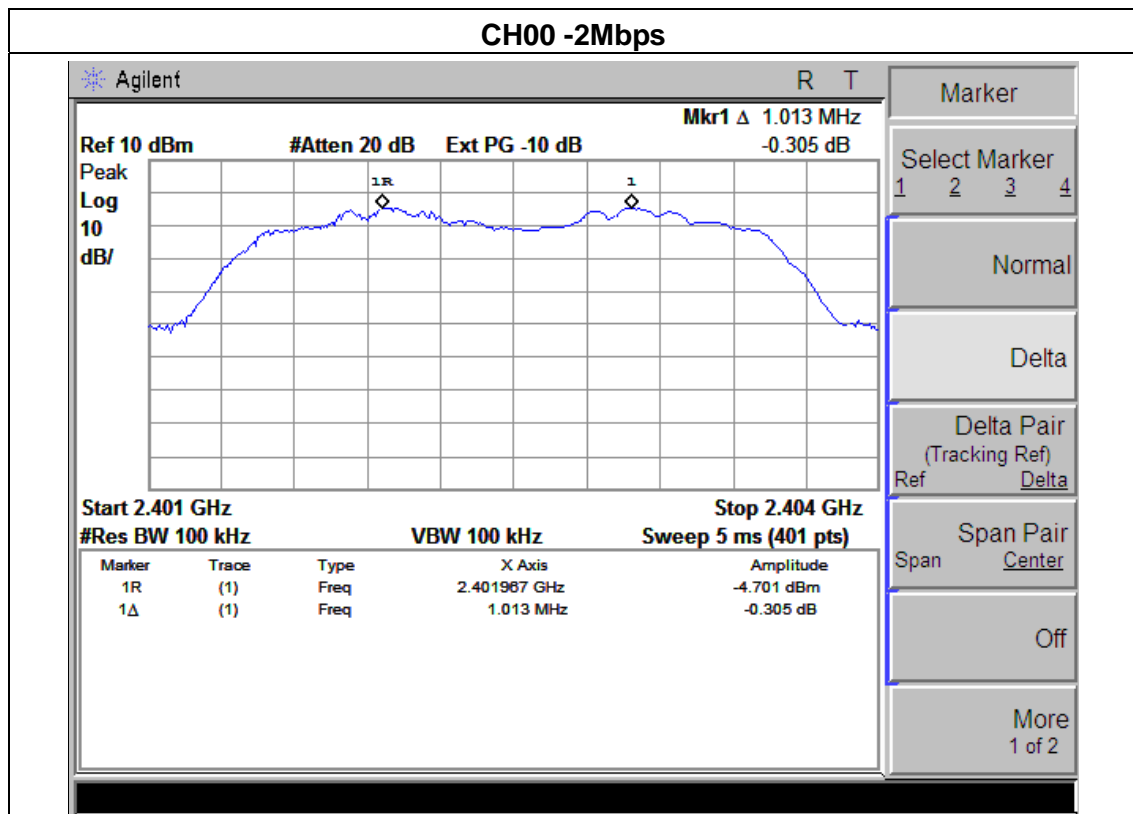

CH39 -2Mbps

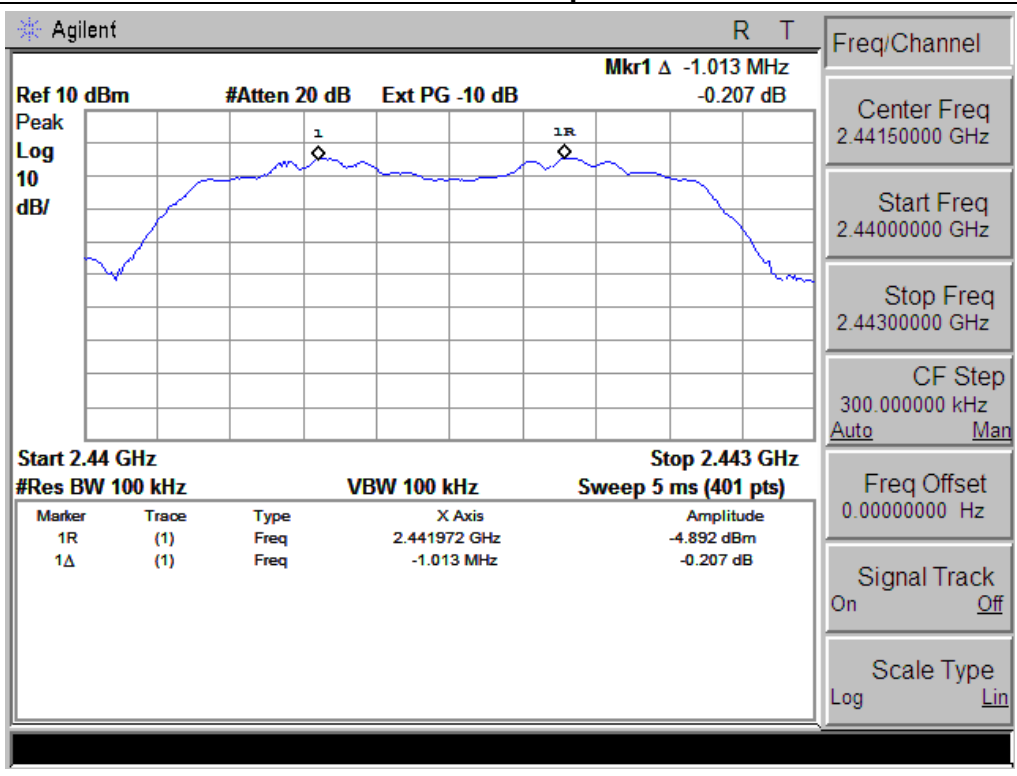

CH78 -2Mbps

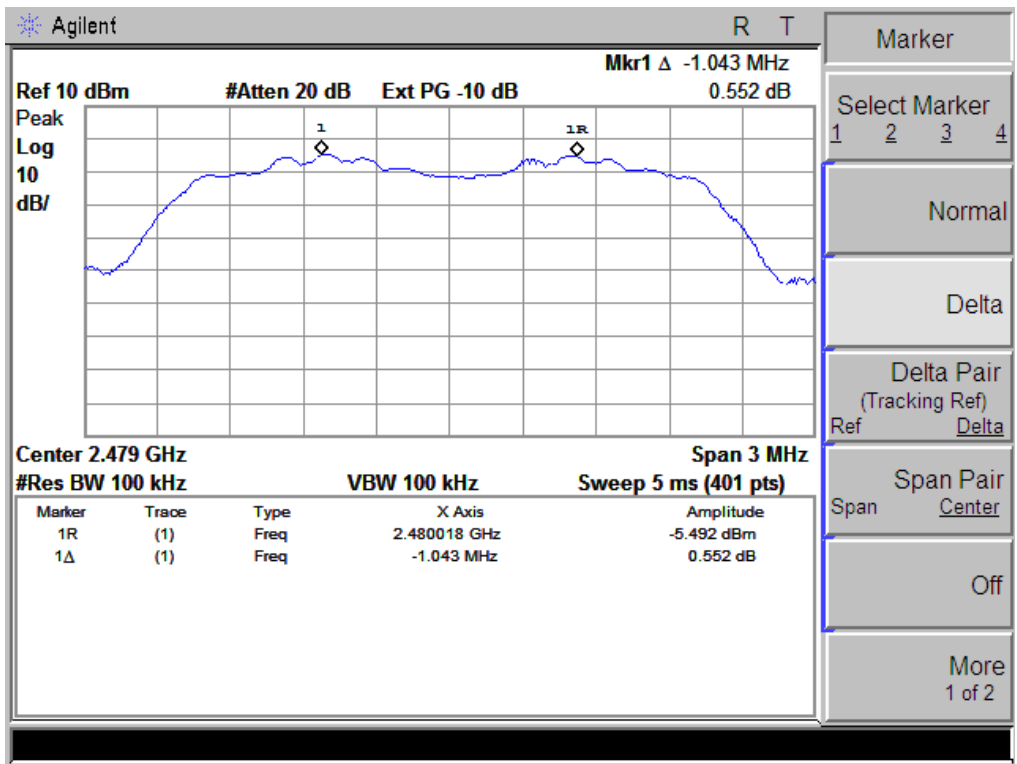

EUT :	38" sound bar 2.1 system with wireless subwoofer	Model Name :	S3821w-C0
Temperature :	25 °C	Relative Humidity :	60%
Pressure :	1012 hPa	Test Voltage :	AC 120V/60Hz
Test Mode :	CH00 / CH39 /CH78 (3Mbps Mode)		

Frequency	Ch. Separation (MHz)	Result
2402 MHz	1.01	Complies
2441 MHz	1.03	Complies
2480 MHz	1.03	Complies

Ch. Separation Limits: >2/3 of 20dB bandwidth

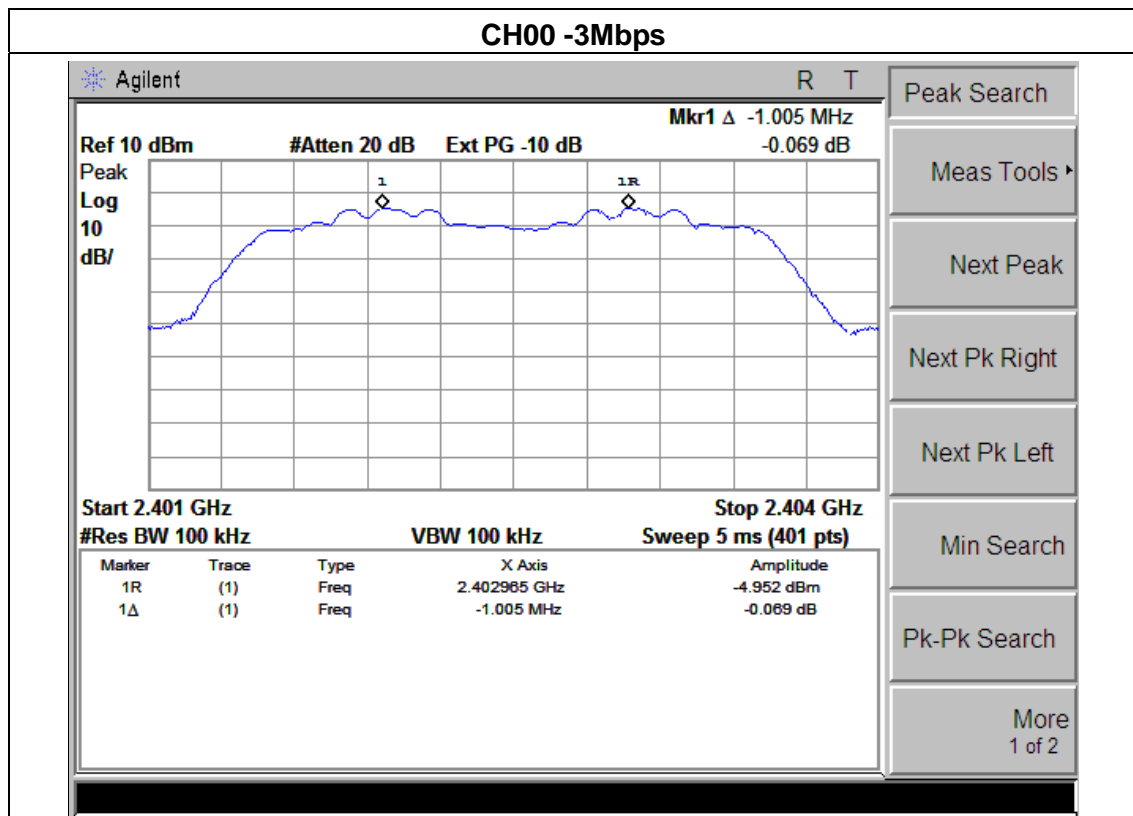

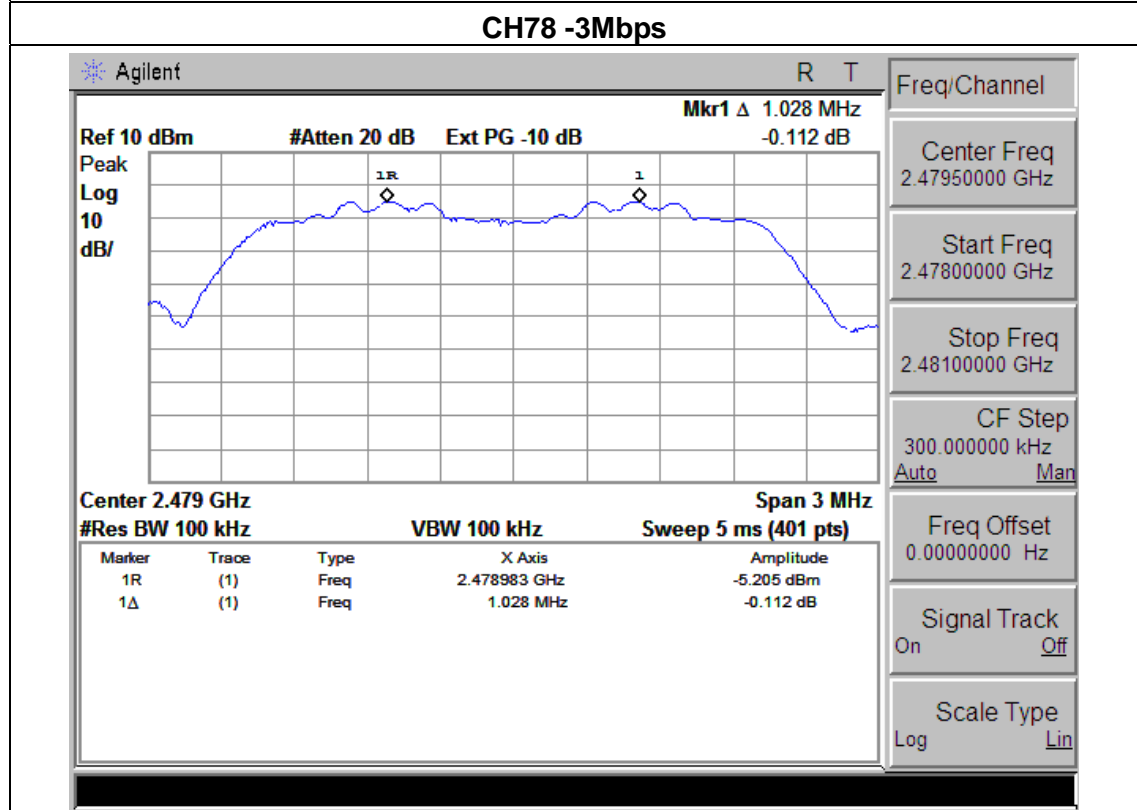
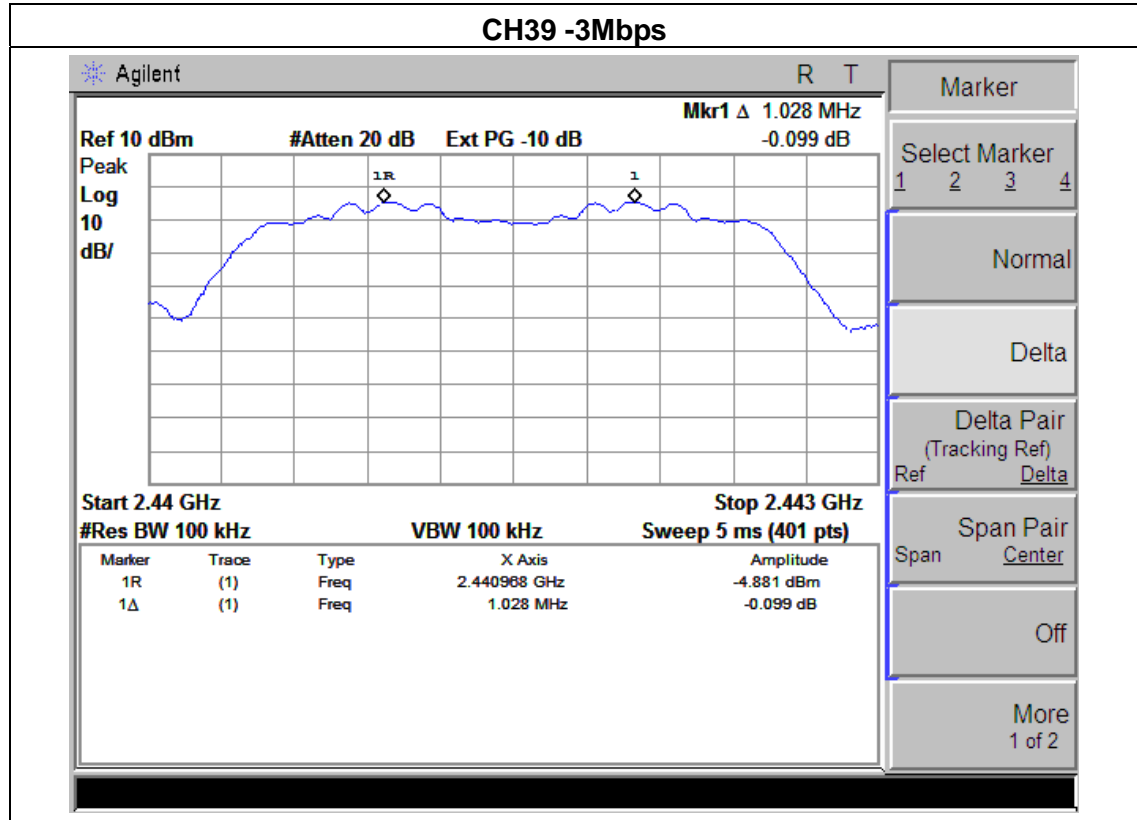

7. BANDWIDTH TEST

7.1 APPLIED PROCEDURES / LIMIT

FCC Part15 (15.247) , Subpart C				
Section	Test Item	Limit	Frequency Range (MHz)	Result
15.247 (a)(1)	Bandwidth	(20dB bandwidth)	2400-2483.5	PASS

Spectrum Parameter	Setting
Attenuation	Auto
Span Frequency	> Measurement Bandwidth or Channel Separation
RB	30 kHz
VB	100 kHz
Detector	Peak
Trace	Max Hold
Sweep Time	Auto

7.1.1 TEST PROCEDURE

- a. The EUT was directly connected to the spectrum analyzer and antenna output port as show in the block diagram below,
- b. Spectrum Setting : RBW= 30KHz, VBW=100KHz, Sweep time = Auto.

7.1.2 DEVIATION FROM STANDARD

No deviation.

7.1.3 TEST SETUP



7.1.4 EUT OPERATION CONDITIONS

The EUT tested system was configured as the statements of 2.4 Unless otherwise a special operating condition is specified in the follows during the testing.

7.1.5 TEST RESULTS

EUT :	38" sound bar 2.1 system with wireless subwoofer	Model Name :	S3821w-C0
Temperature :	25 °C	Relative Humidity :	60%
Pressure :	1012 hPa	Test Voltage :	AC 120V/60Hz
Test Mode :	CH00 / CH39 /C78(1Mbps)		

Channel	Channel Frequency (MHz)	20dB Bandwidth (MHz)	99% Bandwidth (MHz)	Result
Low Channel	2402	935.510	865.911	PASS
Mid Channel	2441	930.583	858.196	PASS
High Channel	2480	913.158	860.265	PASS

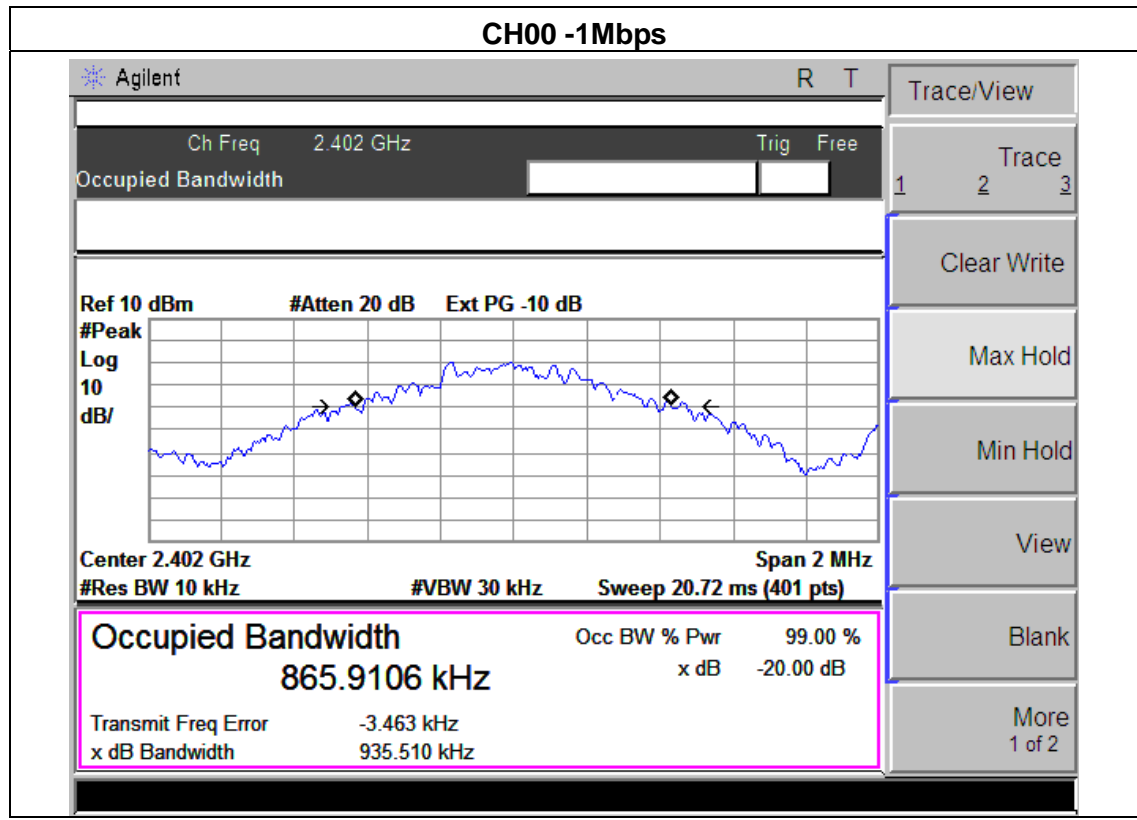

CH39 -1Mbps

Agilent		R	T	Freq/Channel	
Ch Freq 2.441 GHz		Trig Free		Center Freq 2.44100000 GHz	
Occupied Bandwidth				Start Freq 2.44000000 GHz	
Ref 10 dBm #Atten 20 dB Ext PG -10 dB				Stop Freq 2.44200000 GHz	
				CF Step 200.000000 kHz Auto Man	
Center 2.441 GHz		Span 2 MHz		Freq Offset 0.00000000 Hz	
#Res BW 10 kHz		#VBW 30 kHz		Sweep 20.72 ms (401 pts)	
Occupied Bandwidth 858.1956 kHz		Occ BW % Pwr 99.00 %		Signal Track On Off	
		x dB -20.00 dB		Scale Type Log Lin	
Transmit Freq Error -7.662 kHz					
x dB Bandwidth 930.583 kHz					

CH78 -1Mbps

Agilent		R	T	Freq/Channel	
Ch Freq 2.48 GHz		Trig Free		Center Freq 2.48000000 GHz	
Occupied Bandwidth				Start Freq 2.47900000 GHz	
Ref 10 dBm #Atten 20 dB Ext PG -10 dB				Stop Freq 2.48100000 GHz	
				CF Step 200.000000 kHz Auto Man	
Center 2.48 GHz		Span 2 MHz		Freq Offset 0.00000000 Hz	
#Res BW 10 kHz		#VBW 30 kHz		Sweep 20.72 ms (401 pts)	
Occupied Bandwidth 860.2654 kHz		Occ BW % Pwr 99.00 %		Signal Track On Off	
		x dB -20.00 dB		Scale Type Log Lin	
Transmit Freq Error -7.986 kHz					
x dB Bandwidth 913.158 kHz					

EUT :	38" sound bar 2.1 system with wireless subwoofer	Model Name :	S3821w-C0
Temperature :	25 °C	Relative Humidity :	60%
Pressure :	1012 hPa	Test Voltage :	AC 120V/60Hz
Test Mode :	CH00 / CH39 /C78(2Mbps)		

Channel	Channel Frequency (MHz)	20dB Bandwidth (MHz)	99% Bandwidth (MHz)	Result
Low Channel	2402	1.255	1.163	PASS
Mid Channel	2441	1.229	1.168	PASS
High Channel	2480	1.224	1.167	PASS

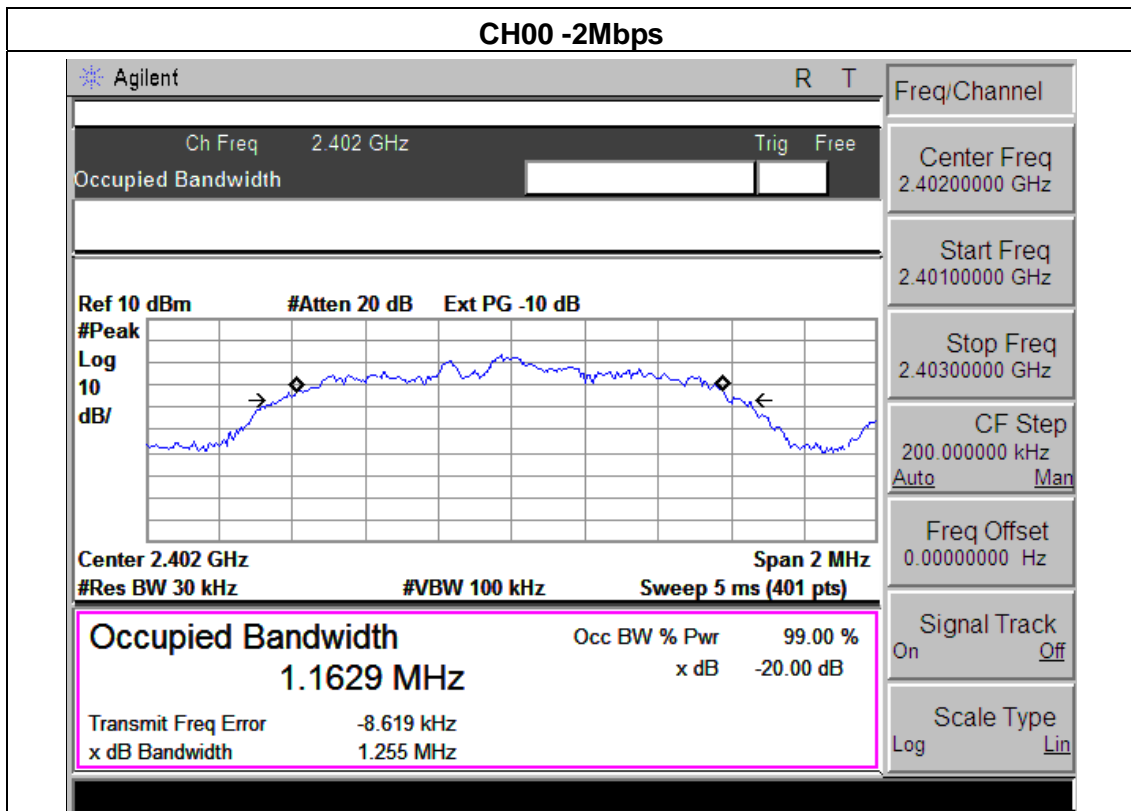

CH39 -2Mbps

Agilent		R	T	Freq/Channel	
Ch Freq 2.441 GHz		Trig Free		Center Freq 2.44100000 GHz	
Occupied Bandwidth				Start Freq 2.44000000 GHz	
Ref 10 dBm #Atten 20 dB Ext PG -10 dB				Stop Freq 2.44200000 GHz	
				CF Step 200.000000 kHz Auto Man	
Center 2.441 GHz		Span 2 MHz		Freq Offset 0.00000000 Hz	
#Res BW 30 kHz		#VBW 100 kHz		Sweep 5 ms (401 pts)	
Occupied Bandwidth 1.1682 MHz		Occ BW % Pwr 99.00 %		Signal Track On Off	
Transmit Freq Error -21.551 kHz		x dB -20.00 dB		Scale Type Log Lin	
x dB Bandwidth 1.229 MHz					

CH78 -2Mbps

Agilent		R	T	Freq/Channel	
Ch Freq 2.48 GHz		Trig Free		Center Freq 2.48000000 GHz	
Occupied Bandwidth				Start Freq 2.47900000 GHz	
Ref 10 dBm #Atten 20 dB Ext PG -10 dB				Stop Freq 2.48100000 GHz	
				CF Step 200.000000 kHz Auto Man	
Center 2.48 GHz		Span 2 MHz		Freq Offset 0.00000000 Hz	
#Res BW 30 kHz		#VBW 100 kHz		Sweep 5 ms (401 pts)	
Occupied Bandwidth 1.1666 MHz		Occ BW % Pwr 99.00 %		Signal Track On Off	
Transmit Freq Error -19.777 kHz		x dB -20.00 dB		Scale Type Log Lin	
x dB Bandwidth 1.224 MHz					

EUT :	38" sound bar 2.1 system with wireless subwoofer	Model Name :	S3821w-C0
Temperature :	25 °C	Relative Humidity :	60%
Pressure :	1012 hPa	Test Voltage :	AC 120V/60Hz
Test Mode :	CH00 / CH39 /C78(3Mbps)		

Channel	Channel Frequency (MHz)	20dB Bandwidth (MHz)	99% Bandwidth (MHz)	Result
Low Channel	2402	1.227	1.155	PASS
Mid Channel	2441	1.231	1.152	PASS
High Channel	2480	1.218	1.149	PASS

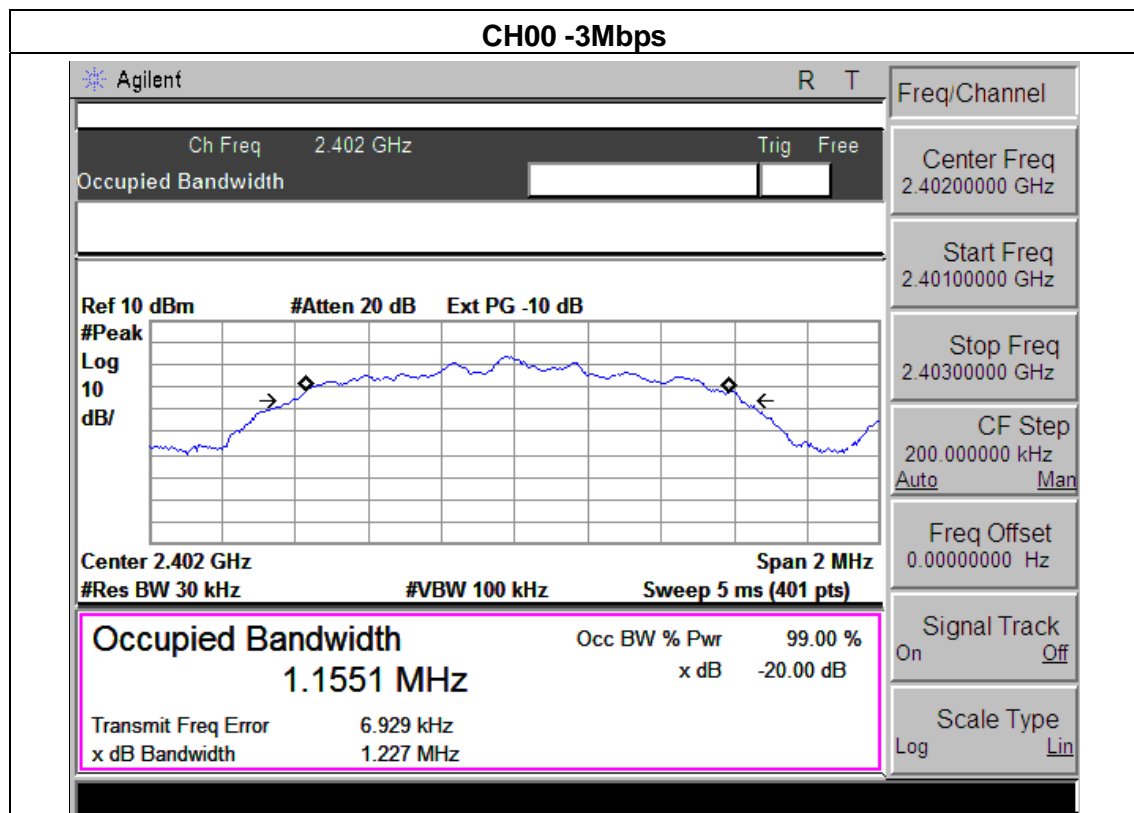

CH39 -3Mbps

Agilent		R	T	Freq/Channel	
Ch Freq 2.441 GHz		Trig Free		Center Freq 2.44100000 GHz	
Occupied Bandwidth				Start Freq 2.44000000 GHz	
Ref 10 dBm #Atten 20 dB Ext PG -10 dB				Stop Freq 2.44200000 GHz	
				CF Step 200.000000 kHz Auto Man	
Center 2.441 GHz		Span 2 MHz		Freq Offset 0.00000000 Hz	
#Res BW 30 kHz		#VBW 100 kHz		Sweep 5 ms (401 pts)	
Occupied Bandwidth 1.1521 MHz		Occ BW % Pwr 99.00 %		Signal Track On Off	
x dB Bandwidth 1.231 MHz		x dB -20.00 dB		Scale Type Log Lin	
Transmit Freq Error -148.985 Hz					

CH78 -3Mbps

Agilent		R	T	Freq/Channel	
Ch Freq 2.48 GHz		Trig Free		Center Freq 2.48000000 GHz	
Occupied Bandwidth				Start Freq 2.47900000 GHz	
Ref 10 dBm #Atten 20 dB Ext PG -10 dB				Stop Freq 2.48100000 GHz	
				CF Step 200.000000 kHz Auto Man	
Center 2.48 GHz		Span 2 MHz		Freq Offset 0.00000000 Hz	
#Res BW 30 kHz		#VBW 100 kHz		Sweep 5 ms (401 pts)	
Occupied Bandwidth 1.1490 MHz		Occ BW % Pwr 99.00 %		Signal Track On Off	
x dB Bandwidth 1.218 MHz		x dB -20.00 dB		Scale Type Log Lin	
Transmit Freq Error -3.287 kHz					

8. PEAK OUTPUT POWER TEST

8.1 APPLIED PROCEDURES / LIMIT

FCC Part15 (15.247) , Subpart C				
Section	Test Item	Limit	Frequency Range (MHz)	Result
15.247 (b)(i)	Peak Output Power	30dBm or 20.96dBm	2400-2483.5	PASS

8.1.1 TEST PROCEDURE

- a. The EUT was directly connected to the spectrum analyzer and antenna output port as show in the block diagram below,
- b. Spectrum Setting : RBW > the 20 dB bandwidth of the emission being measured
 Span = approximately 5 times the 20 dB bandwidth, centered on a hopping channel
 VBW ≥ RBW
 Sweep = auto
 Detector function = peak
 Trace = max hold

8.1.2 DEVIATION FROM STANDARD

No deviation.

8.1.3 TEST SETUP

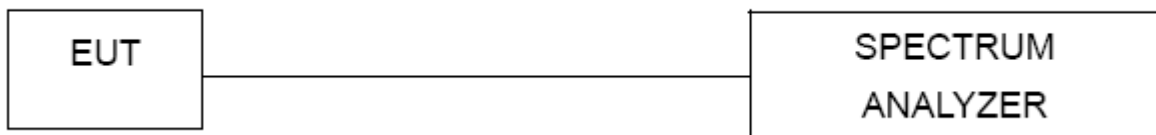

8.1.4 EUT OPERATION CONDITIONS

The EUT tested system was configured as the statements of 2.4 Unless otherwise a special operating condition is specified in the follows during the testing.

8.1.5 TEST RESULTS

EUT :	38" sound bar 2.1 system with wireless subwoofer	Model Name :	S3821w-C0
Temperature :	25 °C	Relative Humidity :	60%
Pressure :	1012 hPa	Test Voltage :	AC 120V/60Hz
Test Mode :	CH00/ CH39 /CH78 (1M/2M/3Mbps Mode)		

Channel	Frequency (MHz)	Output Power (mW)	Limit (dbm)
BDR mode (GFSK)			
Low	2402	-0.334	30
Middle	2441	1.070	30
High	2480	0.781	30
EDR Mode ($\pi/4$ -DQPSK)			
Low	2402	-1.142	20.96
Middle	2441	-1.177	20.96
High	2480	-1.759	20.96
EDR Mode (8 DPSK)			
Low	2402	-0.855	20.96
Middle	2441	-0.970	20.96
High	2480	-1.546	20.96

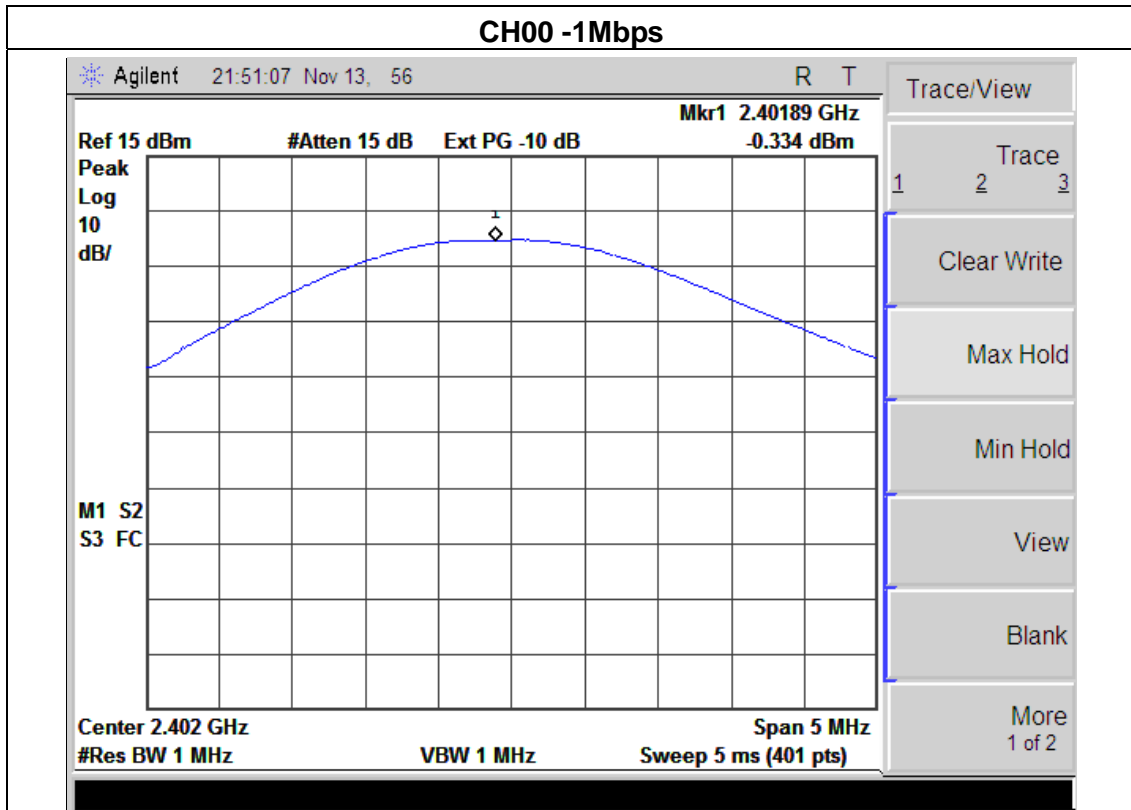

CH39 -1Mbps

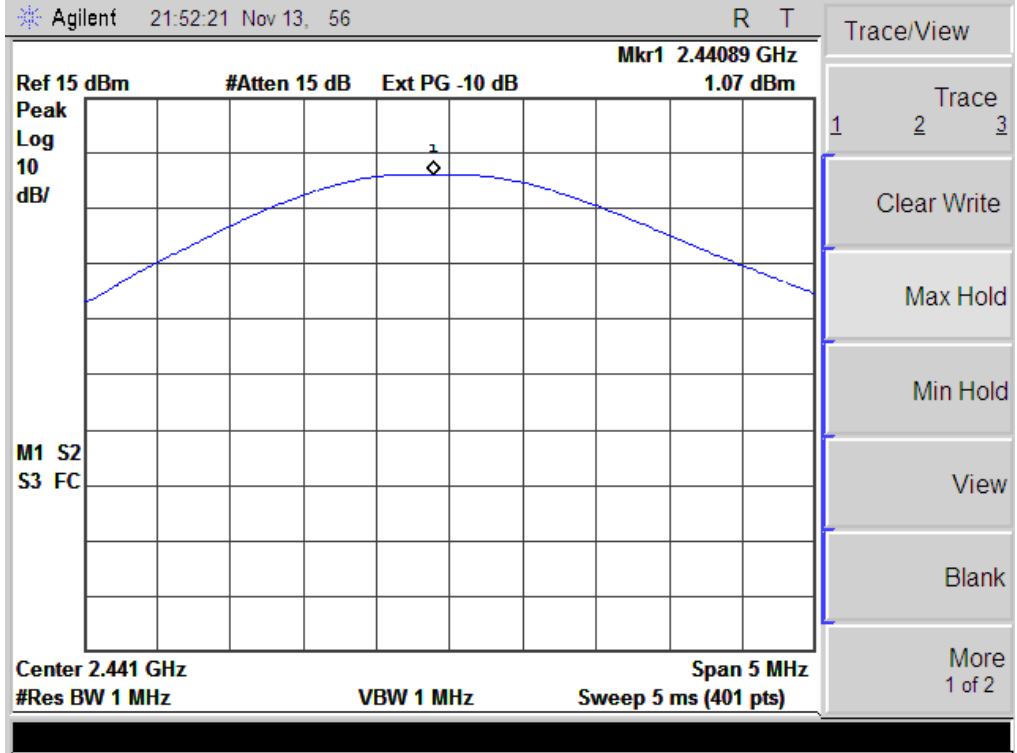

CH78 -1Mbps

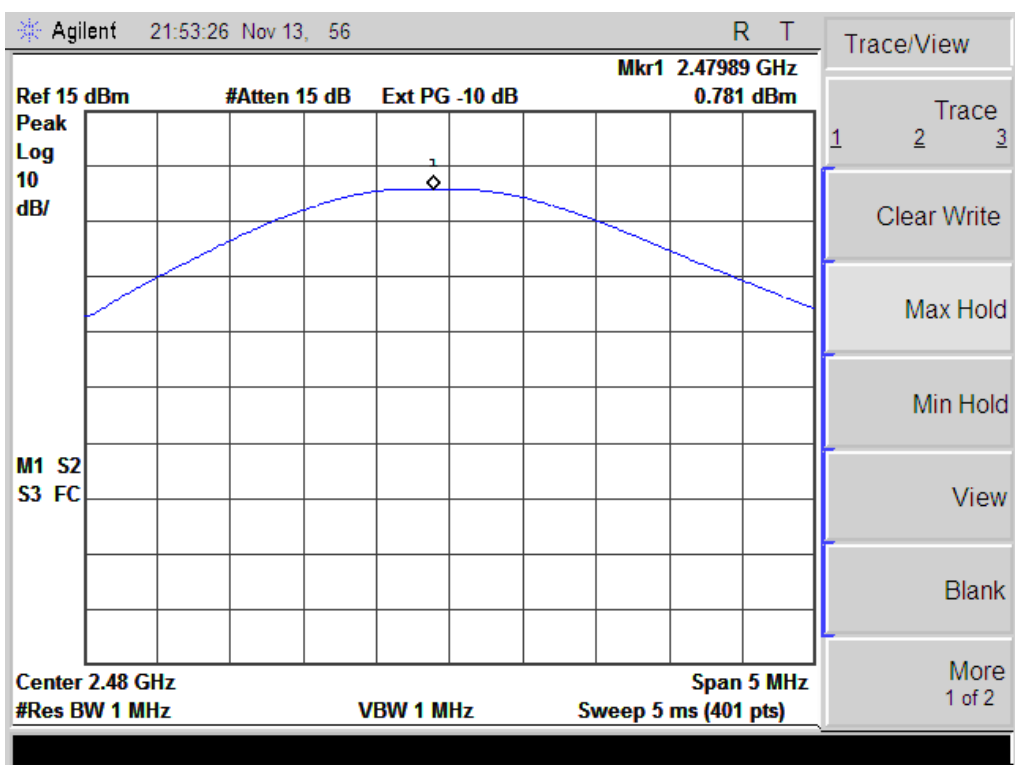

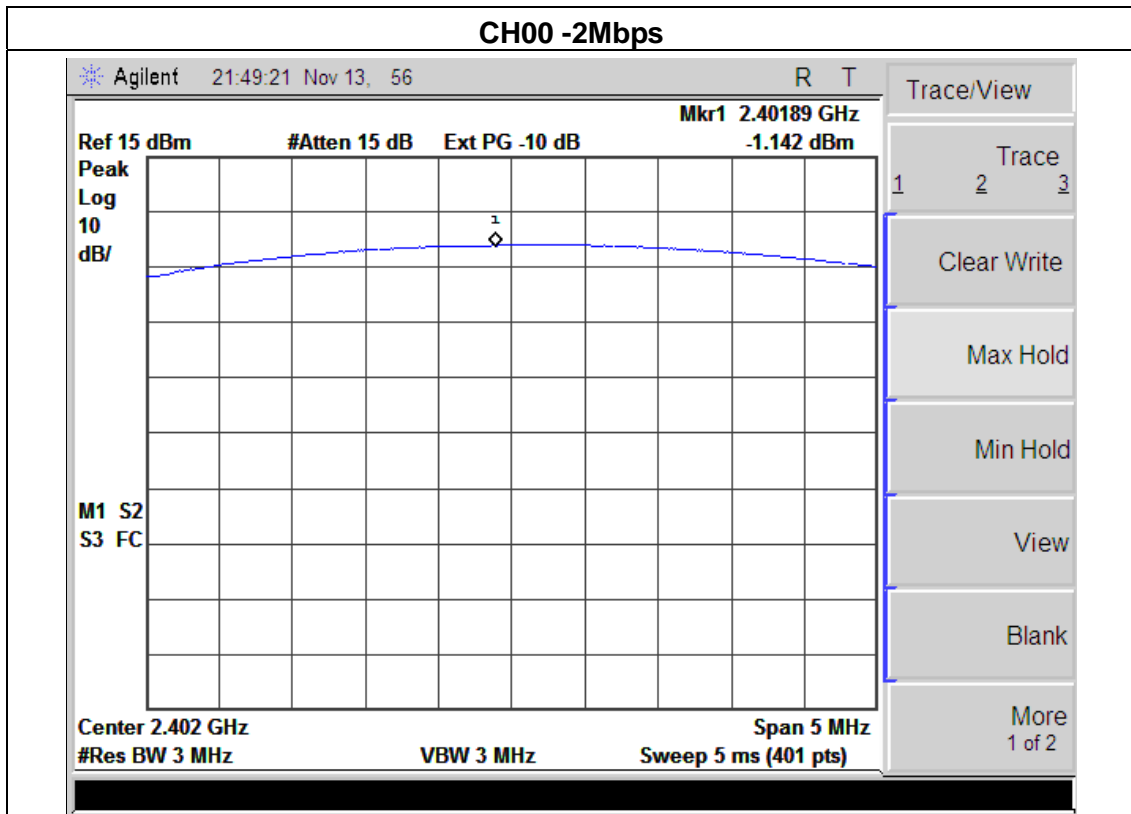

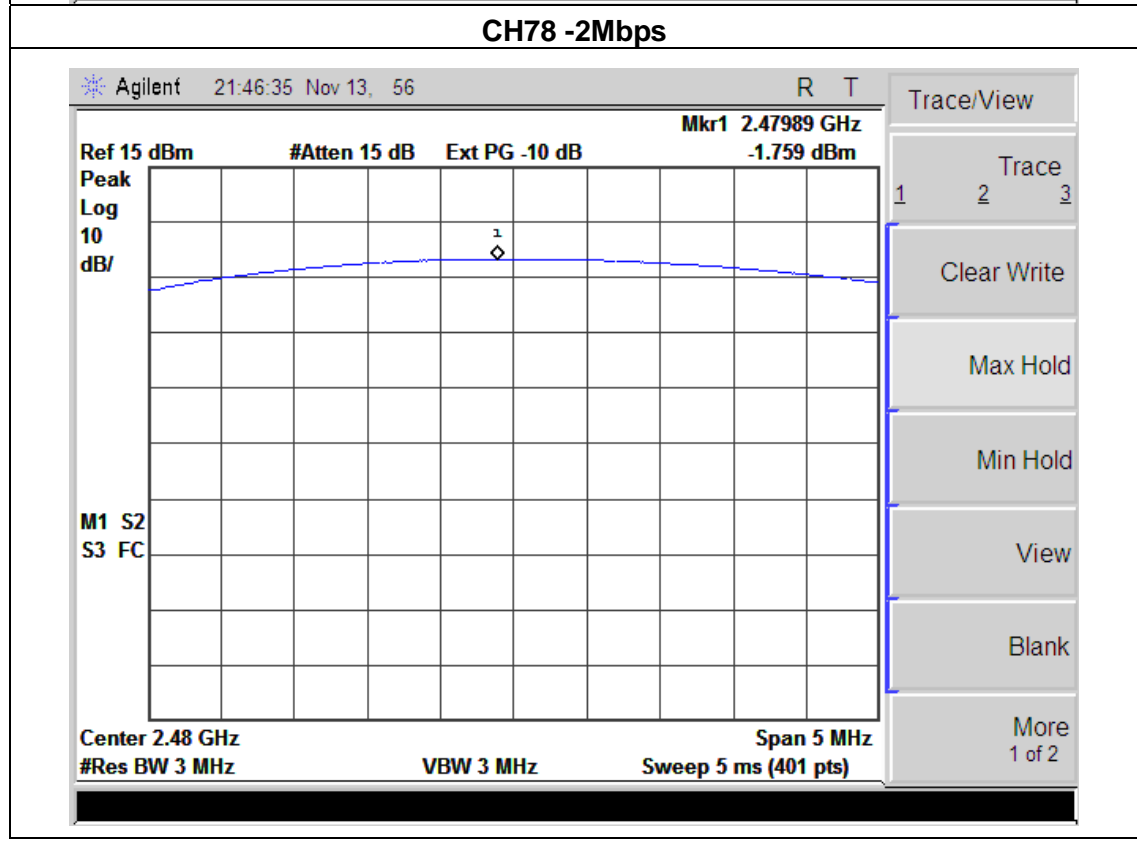
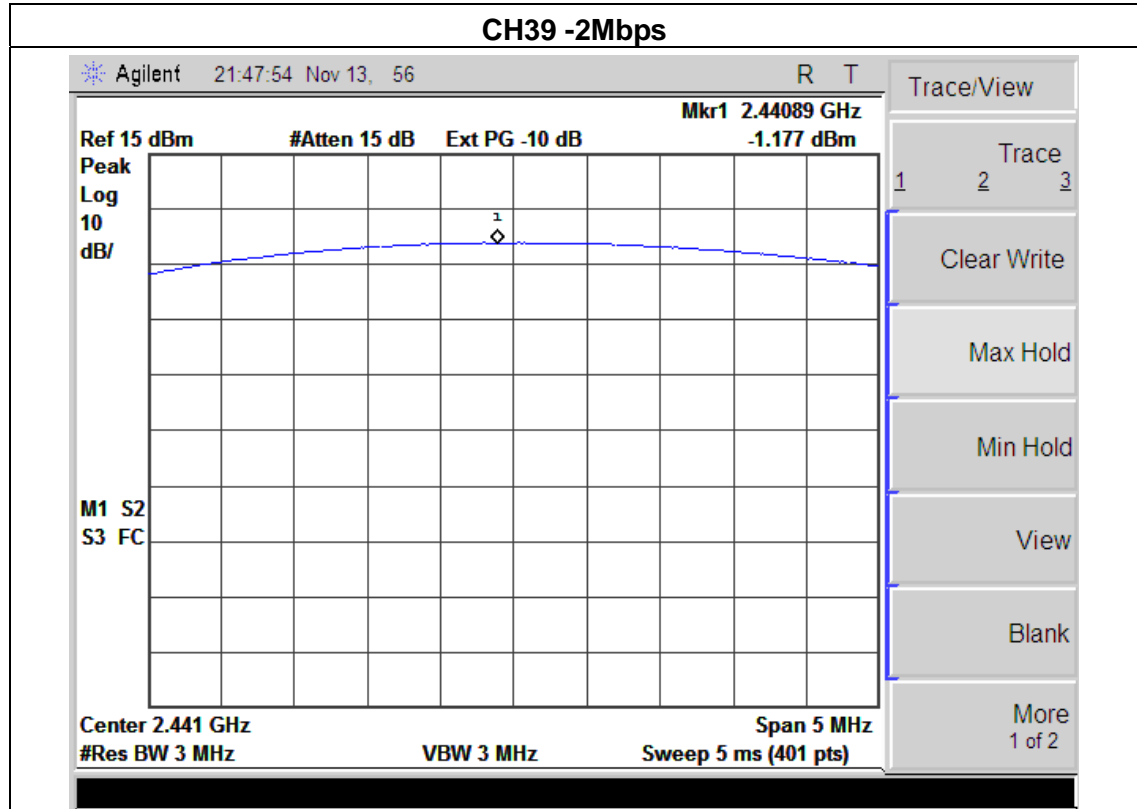

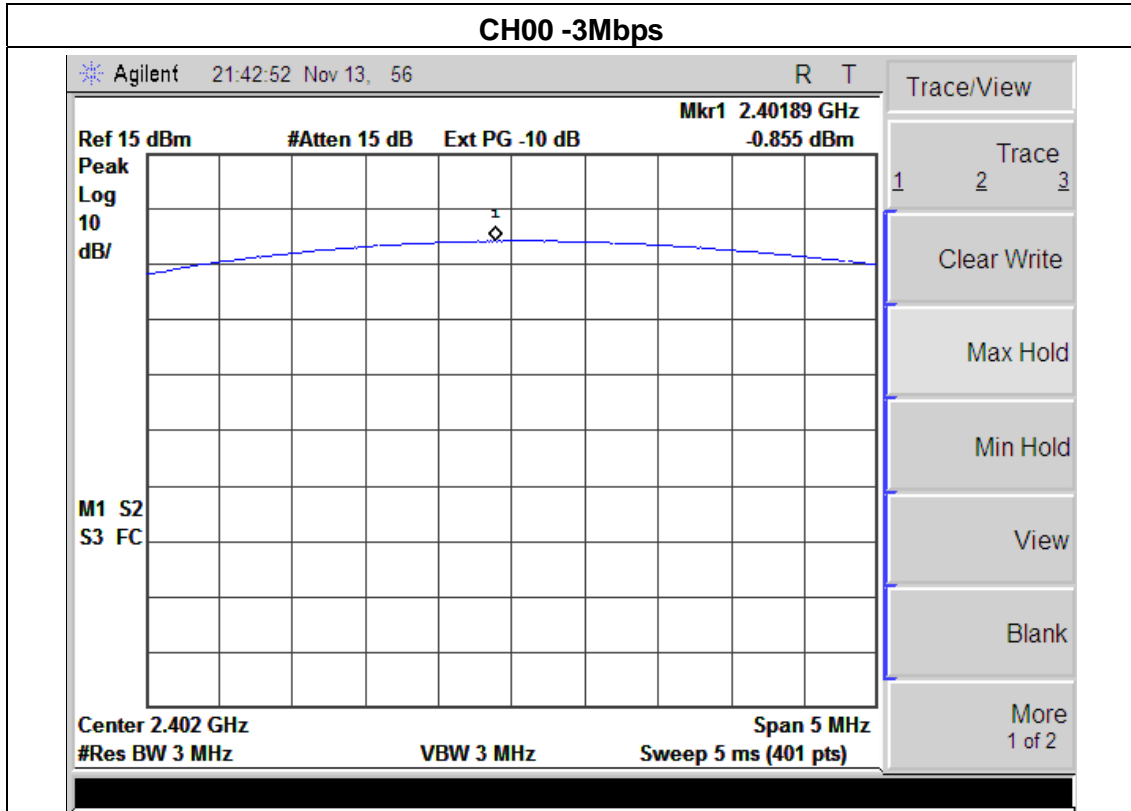

CH39 -3Mbps

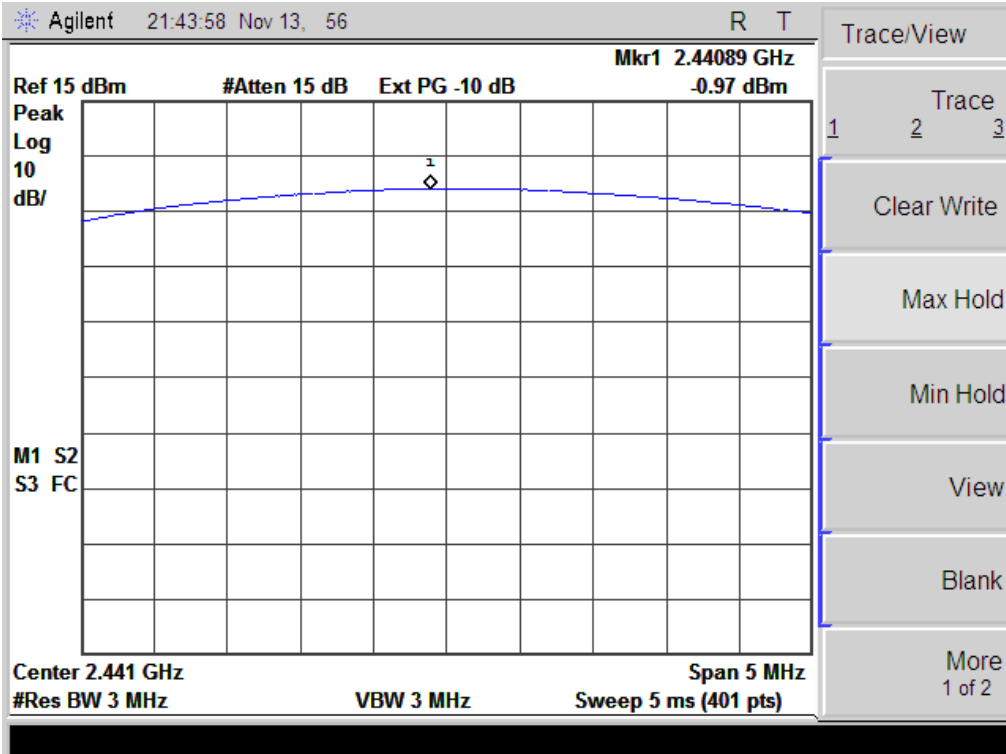

CH78 -3Mbps

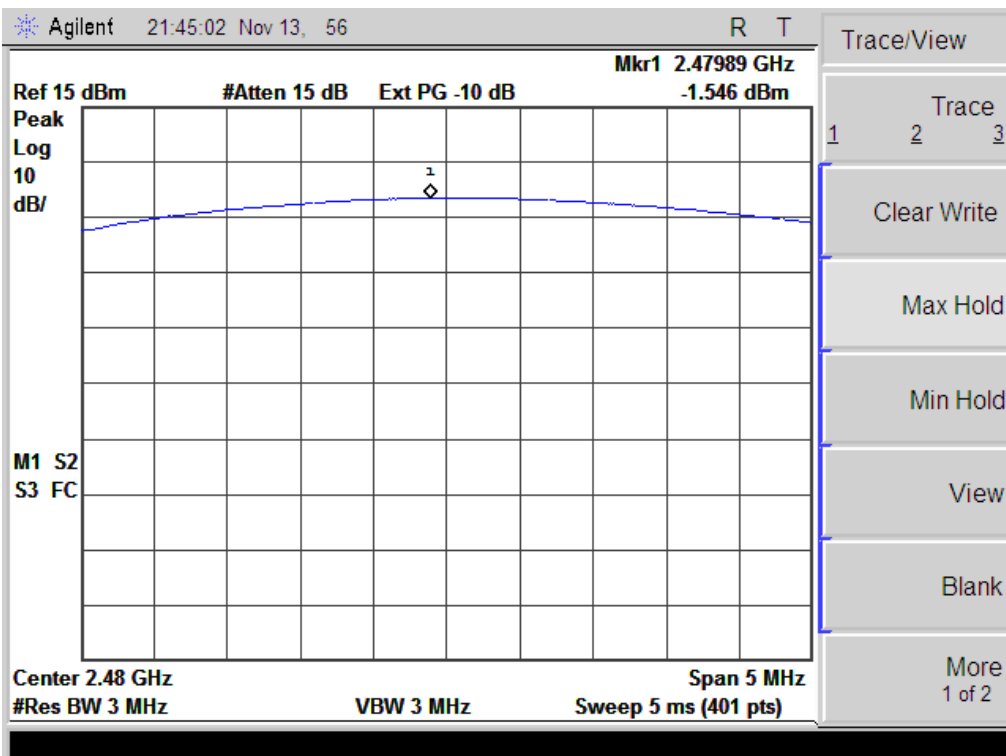

9. ANTENNA REQUIREMENT

9.1 STANDARD REQUIREMENT

15.203 requirement: For intentional device, according to 15.203: an intentional radiator shall be designed to ensure that no antenna other than that furnished by the responsible party shall be used with the device.

9.2 EUT ANTENNA

The EUT antenna is PCB antenna. It comply with the standard requirement.

10. EUT TEST PHOTO

Radiated Measurement Photos

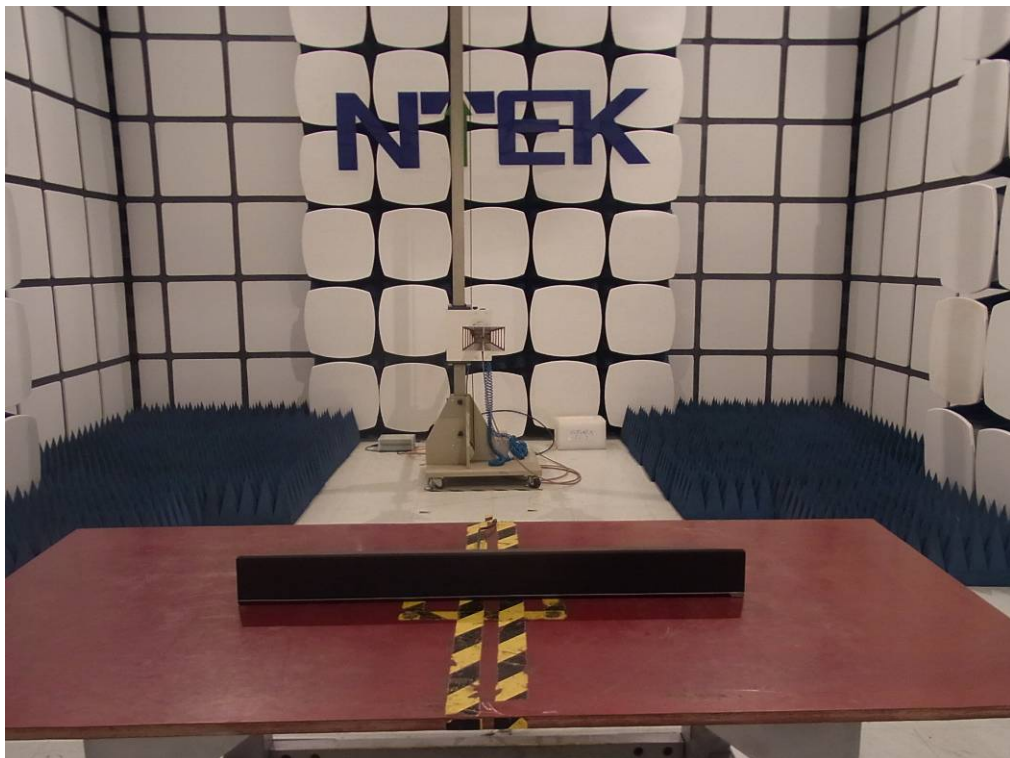

CONDUCTED EMISSION Photos

