

# TEST REPORT

**Application No.:** SZCR2401000384AT  
**Applicant:** Quectel Wireless Solutions Co., Ltd.  
**Address of Applicant:** Building 5, Shanghai Business Park Phase III (Area B), No.1016 Tianlin Road, Minhang District, Shanghai 200233, China  
**Manufacturer:** Quectel Wireless Solutions Co., Ltd.  
**Address of Manufacturer:** Building 5, Shanghai Business Park Phase III (Area B), No.1016 Tianlin Road, Minhang District, Shanghai 200233, China

**Equipment Under Test (EUT):**  
**EUT Name:** 5G Sub-6 GHz Smart Module with Wi-Fi 6E & Bluetooth  
**Model No.:** SG560D-NA  
**Trade Mark:** QUECTEL  
**FCC ID:** XMR2024SG560DNA  
**Standard(s) :** 47 CFR Part 15, Subpart E 15.407  
**Date of Receipt:** 2024-01-29  
**Date of Test:** 2024-02-27 to 2024-03-15  
**Date of Issue:** 2024-03-21

<b>Test Result:</b>	<b>Pass*</b>
---------------------	--------------

\* In the configuration tested, the EUT complied with the standards specified above.

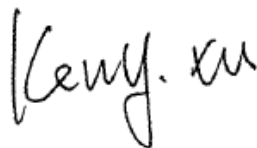

Keny Xu  
EMC Laboratory Manager



Revision Record				
Version	Chapter	Date	Modifier	Remark
01		2024-03-21		Original

<b>Authorized for issue by:</b>			
		<i>Donjon Huang</i>	
		<hr/>	
		<b>Donjon Huang/Project Engineer</b>	
		<i>Eric Fu</i>	
		<hr/>	
		<b>Eric Fu/Reviewer</b>	



Unless otherwise agreed in writing, this document is issued by the Company subject to its General Conditions of Service printed overleaf, available on request or accessible at <https://www.sgs.com/en/Terms-and-Conditions>. Attention is drawn to the limitation of liability, indemnification and jurisdiction issues defined therein. Any holder of this document is advised that information contained hereon reflects the Company's findings at the time of its intervention only and within the limits of Client's instructions, if any. The Company's sole responsibility is to its Client and this document does not exonerate parties to a transaction from exercising all their rights and obligations under the transaction documents. This document cannot be reproduced except in full, without prior written approval of the Company. Any unauthorized alteration, forgery or falsification of the content or appearance of this document is unlawful and offenders may be prosecuted to the fullest extent of the law. Unless otherwise stated the results shown in this test report refer only to the sample(s) tested and such sample(s) are retained for 30 days only.

Attention: To check the authenticity of testing /inspection report & certificate, please contact us at telephone: (86-755) 8307 1443, or email: CN.Doccheck@sgs.com

## 2 Test Summary

Radio Spectrum Technical Requirement				
Item	Standard	Method	Requirement	Result
Antenna Requirement	47 CFR Part 15, Subpart E 15.407	N/A	47 CFR Part 15, Subpart C 15.203	Pass
Transmission in the Absence of Data		N/A	47 CFR Part 15, Subpart E 15.407 (c)	Pass

Radio Spectrum Matter Part				
Item	Standard	Method	Requirement	Result
Conducted Emissions at AC Power Line (150kHz-30MHz)	47 CFR Part 15, Subpart E 15.407	ANSI C63.10 (2020) Section 6.2	47 CFR Part 15, Subpart C 15.207 & Subpart E 15.407 (b)(9)	Pass
Duty Cycle		KDB 789033 II B 1	KDB 789033 D02 II B 1	Pass
99% Bandwidth		KDB 789033 II D	47 CFR Part 15, Subpart E 15.407 (a)(10)	Pass
26dB Emission bandwidth		KDB 789033 D02 II C 1	47 CFR Part 15, Subpart E 15.407 (a)	Pass
Maximum e.i.r.p		KDB 789033 D02 II E	47 CFR Part 15, Subpart E 15.407 (a)(5)	Pass
Maximum Power spectral density		KDB 789033 D02 II F	47 CFR Part 15, Subpart E 15.407 (a)(5)	Pass
In-Band Emissions		KDB 987594 D02 U-NII 6GHz EMC Measurement v02r01	47 CFR Part 15, Subpart E 15.407 (b)(7)	Pass
Radiated Emissions (Below 1GHz)		KDB 789033 D02 II G	47 CFR Part 15, Subpart C 15.209 & Subpart E 15.407(b)	Pass
Radiated Emissions (Above 1GHz)		KDB 789033 D02 II G	47 CFR Part 15, Subpart C 15.209 & Subpart E 15.407(b)	Pass
Radiated Emissions which fall in the restricted bands		KDB 789033 D02 II G	47 CFR Part 15, Subpart C 15.209 & Subpart E 15.407(b)	Pass
Contention-based Protocol		KDB 987594 D02 U-NII 6GHz EMC Measurement v02r01	47 CFR Part 15, Subpart E 15.407 (d)(6)	Pass
Frequency Stability		ANSI C63.10 (2020) Section 6.8	47 CFR Part 15, Subpart E 15.407 (g)	Pass



Unless otherwise agreed in writing, this document is issued by the Company subject to its General Conditions of Service printed overleaf, available on request or accessible at <https://www.sgs.com/en/Terms-and-Conditions>. Attention is drawn to the limitation of liability, indemnification and jurisdiction issues defined therein. Any holder of this document is advised that information contained hereon reflects the Company's findings at the time of its intervention only and within the limits of Client's instructions, if any. The Company's sole responsibility is to its Client and this document does not exonerate parties to a transaction from exercising all their rights and obligations under the transaction documents. This document cannot be reproduced except in full, without prior written approval of the Company. Any unauthorized alteration, forgery or falsification of the content or appearance of this document is unlawful and offenders may be prosecuted to the fullest extent of the law. Unless otherwise stated the results shown in this test report refer only to the sample(s) tested and such sample(s) are retained for 30 days only.

Attention: To check the authenticity of testing /inspection report & certificate, please contact us at telephone: (86-755) 8307 1443, or email: CN.Doccheck@sgs.com  
 No.1 Workshop, M-10, Middle Section, Science & Technology Park, Nanshan District, Shenzhen, Guangdong, China 518057 t (86-755) 26012053 f (86-755) 26710594 www.sgs.com.cn  
 中国·广东·深圳市南山区科技园中区M-10栋1号厂房 邮编: 518057 t (86-755) 26012053 f (86-755) 26710594 sgs.china@sgs.com

### 3 Contents

	Page
<b>1 Cover Page .....</b>	<b>1</b>
<b>2 Test Summary.....</b>	<b>3</b>
<b>3 Contents .....</b>	<b>4</b>
<b>4 General Information.....</b>	<b>6</b>
4.1 Details of E.U.T.....	6
4.2 Description of Support Units.....	7
4.3 Measurement Uncertainty .....	7
4.4 Test Location .....	8
4.5 Test Facility.....	8
4.6 Deviation from Standards.....	8
4.7 Abnormalities from Standard Conditions.....	8
<b>5 Equipment List .....</b>	<b>9</b>
<b>6 Radio Spectrum Technical Requirement.....</b>	<b>14</b>
6.1 Antenna Requirement .....	14
6.1.1 Test Requirement: .....	14
6.1.2 Conclusion.....	14
6.2 Transmission in the Absence of Data .....	16
6.2.1 Test Requirement: .....	16
6.2.2 Conclusion.....	16
<b>7 Radio Spectrum Matter Test Results.....</b>	<b>17</b>
7.1 Conducted Emissions at AC Power Line (150kHz-30MHz) .....	17
7.1.1 E.U.T. Operation .....	17
7.1.2 Test Mode Description .....	17
7.1.3 Test Setup Diagram .....	18
7.1.4 Measurement Procedure and Data.....	18
7.2 Duty Cycle .....	21
7.2.1 E.U.T. Operation .....	21
7.2.2 Test Mode Description .....	21
7.2.3 Test Setup Diagram .....	21
7.2.4 Measurement Procedure and Data.....	21
7.3 99% Bandwidth .....	22
7.3.1 E.U.T. Operation .....	22
7.3.2 Test Mode Description .....	22
7.3.3 Test Setup Diagram .....	22
7.3.4 Measurement Procedure and Data.....	22
7.4 26dB Emission bandwidth .....	23
7.4.1 E.U.T. Operation .....	23
7.4.2 Test Mode Description .....	23
7.4.3 Test Setup Diagram .....	23



Unless otherwise agreed in writing, this document is issued by the Company subject to its General Conditions of Service printed overleaf, available on request or accessible at <https://www.sgs.com/en/Terms-and-Conditions>. Attention is drawn to the limitation of liability, indemnification and jurisdiction issues defined therein. Any holder of this document is advised that information contained hereon reflects the Company's findings at the time of its intervention only and within the limits of Client's instructions, if any. The Company's sole responsibility is to its Client and this document does not exonerate parties to a transaction from exercising all their rights and obligations under the transaction documents. This document cannot be reproduced except in full, without prior written approval of the Company. Any unauthorized alteration, forgery or falsification of the content or appearance of this document is unlawful and offenders may be prosecuted to the fullest extent of the law. Unless otherwise stated the results shown in this test report refer only to the sample(s) tested and such sample(s) are retained for 30 days only.

Attention: To check the authenticity of testing /inspection report & certificate, please contact us at telephone: (86-755) 8307 1443, or email: CN.Doccheck@sgs.com  
 No.1 Workshop, M-10, Middle Section, Science & Technology Park, Nanshan District, Shenzhen, Guangdong, China 518057 t (86-755) 26012053 f (86-755) 26710594 www.sgs.com.cn  
 中国·广东·深圳市南山区科技园中区M-10栋1号厂房 邮编: 518057 t (86-755) 26012053 f (86-755) 26710594 sgs.china@sgs.com



7.4.4 Measurement Procedure and Data.....23

7.5 Maximum e.i.r.p.....24

7.5.1 E.U.T. Operation .....24

7.5.2 Test Mode Description .....24

7.5.3 Test Setup Diagram .....25

7.5.4 Measurement Procedure and Data.....25

7.6 Maximum Power spectral density .....26

7.6.1 E.U.T. Operation .....26

7.6.2 Test Mode Description .....26

7.6.3 Test Setup Diagram .....27

7.6.4 Measurement Procedure and Data.....27

7.7 In-Band Emissions .....28

7.7.1 E.U.T. Operation .....28

7.7.2 Test Mode Description .....28

7.7.3 Test Setup Diagram .....29

7.7.4 Measurement Procedure and Data.....29

7.8 Radiated Emissions (Below 1GHz).....30

7.8.1 E.U.T. Operation .....30

7.8.2 Test Mode Description .....30

7.8.3 Test Setup Diagram .....31

7.8.4 Measurement Procedure and Data.....32

7.9 Radiated Emissions (Above 1GHz).....35

7.9.1 E.U.T. Operation .....35

7.9.2 Test Mode Description .....36

7.9.3 Test Setup Diagram .....36

7.9.4 Measurement Procedure and Data.....37

7.10 Radiated Emissions which fall in the restricted bands .....110

7.10.1 E.U.T. Operation.....111

7.10.2 Test Mode Description .....111

7.10.3 Test Setup Diagram .....111

7.10.4 Measurement Procedure and Data.....112

7.11 Contention-based Protocol .....177

7.11.1 E.U.T. Operation.....177

7.11.2 Test Mode Description .....177

7.11.3 Test Setup Diagram .....178

7.11.4 Measurement Procedure and Data.....178

7.12 Frequency Stability.....179

7.12.1 E.U.T. Operation.....179

7.12.2 Test Mode Description .....179

7.12.3 Test Setup Diagram .....179

7.12.4 Measurement Procedure and Data.....179

**8 Test Setup Photo .....180**

**9 Appendix.....181**



Unless otherwise agreed in writing, this document is issued by the Company subject to its General Conditions of Service printed overleaf, available on request or accessible at <https://www.sgs.com/en/Terms-and-Conditions>. Attention is drawn to the limitation of liability, indemnification and jurisdiction issues defined therein. Any holder of this document is advised that information contained hereon reflects the Company's findings at the time of its intervention only and within the limits of Client's instructions, if any. The Company's sole responsibility is to its Client and this document does not exonerate parties to a transaction from exercising all their rights and obligations under the transaction documents. This document cannot be reproduced except in full, without prior written approval of the Company. Any unauthorized alteration, forgery or falsification of the content or appearance of this document is unlawful and offenders may be prosecuted to the fullest extent of the law. Unless otherwise stated the results shown in this test report refer only to the sample(s) tested and such sample(s) are retained for 30 days only.

Attention: To check the authenticity of testing /inspection report & certificate, please contact us at telephone: (86-755) 8307 1443, or email: CN.Doccheck@sgs.com

No.1 Workshop, M-10, Middle Section, Science & Technology Park, Nanshan District, Shenzhen, Guangdong, China 518057 t (86-755) 26012053 f (86-755) 26710594 www.sgs.com.cn  
 中国·广东·深圳市南山区科技园中区M-10栋1号厂房 邮编: 518057 t (86-755) 26012053 f (86-755) 26710594 sgs.china@sgs.com

## 4 General Information

### 4.1 Details of E.U.T.

EUT Description:	5G Sub-6 GHz Smart Module with Wi-Fi 6E & Bluetooth	
Model No.:	SG560D-NA	
Trade Mark:	QUECTEL	
Hardware Version:	R1.0	
Software Version:	SG560DNAPAR03A05	
Power Supply:	Power form the mainboard which with AC/DC adapter Model No: GQ36-120300-AX Input: AC100-240V~50/60Hz 1.0A MAX Output: DC12.0V 0.3A 36.0W	
IEEE 802.11 WLAN Mode Supported:	<input checked="" type="checkbox"/> 802.11a (20 MHz channel bandwidth), <input checked="" type="checkbox"/> 802.11ax (20 MHz channel bandwidth) <input checked="" type="checkbox"/> 802.11ax (40 MHz channel bandwidth) <input checked="" type="checkbox"/> 802.11ax (80 MHz channel bandwidth) <input checked="" type="checkbox"/> 802.11ax (160 MHz channel bandwidth)	
Operation Frequency:	IEEE 802.11 a/ax(HE20/40/80/160): 5925 MHz ~ 6425 MHz IEEE 802.11 a/ax(HE20/40/80/160): 6425 MHz ~ 6525 MHz IEEE 802.11 a/ax(HE20/40/80/160): 6525 MHz ~ 6875 MHz IEEE 802.11 a/ax(HE20/40/80/160): 6875 MHz ~ 7125 MHz	
Type of Modulation:	OFDM/OFDMA	
FCC Classification:	6GHz Low Power Indoor Access Point (6ID)	
Antenna Type:	integrated antenna	
Smart System:	<input type="checkbox"/> SISO	802.11a/ax
	<input checked="" type="checkbox"/> MIMO	802.11ax: 2Tx & 2Rx
	<input checked="" type="checkbox"/> Diversity	802.11a: 2Tx & 2Rx
Antenna Gain:	5925 MHz ~ 6425 MHz: 1.6dBi(Ant5); 1.6dBi(Ant6) 6425 MHz ~ 6525 MHz: 1.6dBi(Ant5); 1.6dBi(Ant6) 6525 MHz ~ 6875 MHz: 1.6dBi(Ant5); 1.6dBi(Ant6) 6875 MHz ~ 7125 MHz: 1.6dBi(Ant5); 1.6dBi(Ant6)	
	Note: The antenna gain are derived from the gain information report provided by the manufacturer.	
RF Cable:	1.5dB	
Remark:	As above information is provided and confirmed by the applicant. SGS is not liable to the accuracy,	



suitability, reliability or/and integrity of the information.

#### 4.2 Description of Support Units

Description	Manufacturer	Model No.
Mother board	QUECTEL	SMART-5G-EVB_V1.3
Adapter	Dong Guan City GangQi Electronic Co.,Ltd	GQ36-120300-AX

Remark: all above the information of table are provided by client.

#### 4.3 Measurement Uncertainty

Test Item	Measurement Uncertainty
Conducted Emissions at AC Power Line (150kHz-30MHz)	± 3.1dB
Duty Cycle	± 0.37%
99% Bandwidth	± 3%
26dB Emission bandwidth	± 3%
In-Band Emissions	± 3%
Maximum e.i.r.p	± 0.75dB
Maximum Power spectral density	± 2.84dB
Radiated Emissions (Below 1GHz)	± 6.0dB for 3m; ± 5.0dB for 10m
Radiated Emissions (Above 1GHz)	± 4.6dB (1-18GHz); ± 4.8dB (18-40GHz)
Radiated Emissions which fall in the restricted bands	± 6.0dB (below 1GHz); ± 4.6dB (above 1GHz);
Contention-based Protocol	± 3%
Frequency Stability	± 7.25 x 10 <sup>-8</sup>

Remark:

The U<sub>lab</sub> (lab Uncertainty) is less than U<sub>CISPR/ETSI</sub> (CISPR/ETSI Uncertainty), so the test results

- compliance is deemed to occur if no measured disturbance level exceeds the disturbance limit;
- non-compliance is deemed to occur if any measured disturbance level exceeds the disturbance limit.





#### 4.4 Test Location

All tests were performed at:

SGS-CSTC Standards Technical Services Co., Ltd., Shenzhen Branch

No. 1 Workshop, M-10, Middle Section, Science & Technology Park, Nanshan District, Shenzhen, Guangdong, China. 518057.

Tel: +86 755 2601 2053 Fax: +86 755 2671 0594

No tests were sub-contracted.

#### 4.5 Test Facility

The test facility is recognized, certified, or accredited by the following organizations:

• **A2LA (Certificate No. 3816.01)**

SGS-CSTC Standards Technical Services Co., Ltd., Shenzhen EMC Laboratory is accredited by the American Association for Laboratory Accreditation(A2LA). Certificate No. 3816.01.

• **VCCI (Member No. 1937)**

The 3m Fully-anechoic chamber for above 1GHz, 10m Semi-anechoic chamber for below 1GHz, Shielded Room for Mains Port Conducted Interference Measurement and Telecommunication Port Conducted Interference Measurement of SGS-CSTC Standards Technical Services Co., Ltd. Shenzhen EMC laboratory have been registered in accordance with the Regulations for Voluntary Control Measures with Registration No.: G-20026, R-14188, C-12383 and T-11153 respectively.

• **FCC –Designation Number: CN1336**

SGS-CSTC Standards Technical Services Co., Ltd., Shenzhen EMC Laboratory has been recognized as an accredited testing laboratory.

Designation Number: CN1336. Test Firm Registration Number: 787754.

• **Innovation, Science and Economic Development Canada**

SGS-CSTC Standards Technical Services Co., Ltd., Shenzhen EMC Laboratory has been recognized by ISED as an accredited testing laboratory.

CAB identifier: CN0006.

IC#: 4620C.

#### 4.6 Deviation from Standards

None

#### 4.7 Abnormalities from Standard Conditions

None



Unless otherwise agreed in writing, this document is issued by the Company subject to its General Conditions of Service printed overleaf, available on request or accessible at <https://www.sgs.com/en/Terms-and-Conditions>. Attention is drawn to the limitation of liability, indemnification and jurisdiction issues defined therein. Any holder of this document is advised that information contained hereon reflects the Company's findings at the time of its intervention only and within the limits of Client's instructions, if any. The Company's sole responsibility is to its Client and this document does not exonerate parties to a transaction from exercising all their rights and obligations under the transaction documents. This document cannot be reproduced except in full, without prior written approval of the Company. Any unauthorized alteration, forgery or falsification of the content or appearance of this document is unlawful and offenders may be prosecuted to the fullest extent of the law. Unless otherwise stated the results shown in this test report refer only to the sample(s) tested and such sample(s) are retained for 30 days only.

Attention: To check the authenticity of testing /inspection report & certificate, please contact us at telephone: (86-755) 8307 1443, or email: CN.Doccheck@sgs.com



## 5 Equipment List

Conducted Emissions at AC Power Line (150kHz-30MHz)					
Equipment	Manufacturer	Model No.	Inventory No.	Cal Date	Cal Due Date
Shielding Room	ZhongYu Electron	GB-88	SEM001-06	2022-05-14	2025-05-13
EMI Test Receiver	Rohde&Schwarz	ESCI	SEM004-02	2023-03-20	2024-03-19
Matching Pad	N/A	N/A	SEM021-23	2023-03-22	2024-03-21
Matching Pad	N/A	N/A	SEM021-24	2023-03-22	2024-03-21
Measurement Software	AUDIX	e3 V8.2014-6-27a	N/A	N/A	N/A
Coaxial Cable	SGS	N/A	SEM024-01	2023-07-07	2024-07-06
LISN	Rohde&Schwarz	ENV216	SEM007-01	2023-09-19	2024-09-18
LISN	ETS-LINDGREN	3816/2	SEM007-02	2023-03-20	2024-03-19

Duty Cycle					
Equipment	Manufacturer	Model No.	Inventory No.	Cal Date	Cal Due Date
DC Power Supply	Chroma	62012P-80-60	SEM011-11	2023-10-19	2024-10-18
MXA Signal Analyzer	KEYSIGHT	N9020A	SEM004-19	2023-03-21	2024-03-20
Signal Generator	KEYSIGHT	N5173B	SEM006-05	2023-09-19	2024-09-18
Measurement Software	TST PASS	TST PASS V2.0	N/A	N/A	N/A
Coaxial Cable	SGS	N/A	SEM031-01	2023-07-07	2024-07-06
Attenuator	Huber+Suhner	6620_SMA-50-1	SEM021-09	2023-03-31	2024-03-30
Programmable Temperature & Humidity Chamber	Votsch Industrietechnik GmbH	VT 4002	SEM002-15	2023-03-21	2024-03-20

99% Bandwidth					
Equipment	Manufacturer	Model No.	Inventory No.	Cal Date	Cal Due Date
DC Power Supply	Chroma	62012P-80-60	SEM011-11	2023-10-19	2024-10-18
MXA Signal Analyzer	KEYSIGHT	N9020A	SEM004-19	2023-03-21	2024-03-20
Signal Generator	KEYSIGHT	N5173B	SEM006-05	2023-09-19	2024-09-18
Measurement Software	TST PASS	TST PASS V2.0	N/A	N/A	N/A
Coaxial Cable	SGS	N/A	SEM031-01	2023-07-07	2024-07-06
Attenuator	Huber+Suhner	6620_SMA-50-1	SEM021-09	2023-03-31	2024-03-30
Programmable Temperature & Humidity Chamber	Votsch Industrietechnik GmbH	VT 4002	SEM002-15	2023-03-21	2024-03-20



Unless otherwise agreed in writing, this document is issued by the Company subject to its General Conditions of Service printed overleaf, available on request or accessible at <https://www.sgs.com/en/Terms-and-Conditions>. Attention is drawn to the limitation of liability, indemnification and jurisdiction issues defined therein. Any holder of this document is advised that information contained herein reflects the Company's findings at the time of its intervention only and within the limits of Client's instructions, if any. The Company's sole responsibility is to its Client and this document does not exonerate parties to a transaction from exercising all their rights and obligations under the transaction documents. This document cannot be reproduced except in full, without prior written approval of the Company. Any unauthorized alteration, forgery or falsification of the content or appearance of this document is unlawful and offenders may be prosecuted to the fullest extent of the law. Unless otherwise stated the results shown in this test report refer only to the sample(s) tested and such sample(s) are retained for 30 days only.

Attention: To check the authenticity of testing /inspection report & certificate, please contact us at telephone: (86-755) 8307 1443, or email: [CN.Doccheck@sgs.com](mailto:CN.Doccheck@sgs.com)

SGS-CSTC Standards Technical Services Co., Ltd. Shenzhen Branch Laboratory  
 No.1 Workshop, M-10, Middle Section, Science & Technology Park, Nanshan District, Shenzhen, Guangdong, China 518057 t (86-755) 26012053 f (86-755) 26710594 www.sgs.com.cn  
 中国·广东·深圳市南山区科技园中区M-10栋1号厂房 邮编: 518057 t (86-755) 26012053 f (86-755) 26710594 sgs.china@sgs.com

<b>26dB Emission bandwidth</b>					
<b>Equipment</b>	<b>Manufacturer</b>	<b>Model No.</b>	<b>Inventory No.</b>	<b>Cal Date</b>	<b>Cal Due Date</b>
DC Power Supply	Chroma	62012P-80-60	SEM011-11	2023-10-19	2024-10-18
MXA Signal Analyzer	KEYSIGHT	N9020A	SEM004-19	2023-03-21	2024-03-20
Signal Generator	KEYSIGHT	N5173B	SEM006-05	2023-09-19	2024-09-18
Measurement Software	TST PASS	TST PASS V2.0	N/A	N/A	N/A
Coaxial Cable	SGS	N/A	SEM031-01	2023-07-07	2024-07-06
Attenuator	Huber+Suhner	6620_SMA-50-1	SEM021-09	2023-03-31	2024-03-30
Programmable Temperature & Humidity Chamber	Votsch Industrietechnik GmbH	VT 4002	SEM002-15	2023-03-21	2024-03-20

<b>In-Band Emissions</b>					
<b>Equipment</b>	<b>Manufacturer</b>	<b>Model No.</b>	<b>Inventory No.</b>	<b>Cal Date</b>	<b>Cal Due Date</b>
DC Power Supply	Chroma	62012P-80-60	SEM011-11	2023-10-19	2024-10-18
MXA Signal Analyzer	KEYSIGHT	N9020A	SEM004-19	2023-03-21	2024-03-20
Signal Generator	KEYSIGHT	N5173B	SEM006-05	2023-09-19	2024-09-18
Measurement Software	TST PASS	TST PASS V2.0	N/A	N/A	N/A
Coaxial Cable	SGS	N/A	SEM031-01	2023-07-07	2024-07-06
Attenuator	Huber+Suhner	6620_SMA-50-1	SEM021-09	2023-03-31	2024-03-30
Programmable Temperature & Humidity Chamber	Votsch Industrietechnik GmbH	VT 4002	SEM002-15	2023-03-21	2024-03-20

<b>Maximum e.i.r.p</b>					
<b>Equipment</b>	<b>Manufacturer</b>	<b>Model No.</b>	<b>Inventory No.</b>	<b>Cal Date</b>	<b>Cal Due Date</b>
Power Sensor	TST PASS	TSPS2023R	SEM009-26	2023-04-01	2024-03-31
Power Sensor	KEYSIGHT	U2021XA	SEM009-16	2023-03-21	2024-03-20
DC Power Supply	Chroma	62012P-80-60	SEM011-11	2023-10-19	2024-10-18
MXA Signal Analyzer	KEYSIGHT	N9020A	SEM004-19	2023-03-21	2024-03-20
Signal Generator	KEYSIGHT	N5173B	SEM006-05	2023-09-19	2024-09-18
Measurement Software	TST PASS	TST PASS V2.0	N/A	N/A	N/A
Coaxial Cable	SGS	N/A	SEM031-01	2023-07-07	2024-07-06
Attenuator	Huber+Suhner	6620_SMA-50-1	SEM021-09	2023-03-31	2024-03-30



Unless otherwise agreed in writing, this document is issued by the Company subject to its General Conditions of Service printed overleaf, available on request or accessible at <https://www.sgs.com/en/Terms-and-Conditions>. Attention is drawn to the limitation of liability, indemnification and jurisdiction issues defined therein. Any holder of this document is advised that information contained herein reflects the Company's findings at the time of its intervention only and within the limits of Client's instructions, if any. The Company's sole responsibility is to its Client and this document does not exonerate parties to a transaction from exercising all their rights and obligations under the transaction documents. This document cannot be reproduced except in full, without prior written approval of the Company. Any unauthorized alteration, forgery or falsification of the content or appearance of this document is unlawful and offenders may be prosecuted to the fullest extent of the law. Unless otherwise stated the results shown in this test report refer only to the sample(s) tested and such sample(s) are retained for 30 days only.

Attention: To check the authenticity of testing /inspection report & certificate, please contact us at telephone: (86-755) 8307 1443, or email: CN.Doccheck@sgs.com

No.1 Workshop, M-10, Middle Section, Science & Technology Park, Nanshan District, Shenzhen, Guangdong, China 518057 t (86-755) 26012053 f (86-755) 26710594 www.sgs.com.cn  
 中国·广东·深圳市南山区科技园中区M-10栋1号厂房 邮编: 518057 t (86-755) 26012053 f (86-755) 26710594 sgs.china@sgs.com

Programmable Temperature & Humidity Chamber	Votsch Industrietechnik GmbH	VT 4002	SEM002-15	2023-03-21	2024-03-20
---	------------------------------	---------	-----------	------------	------------

**Maximum Power spectral density**

Equipment	Manufacturer	Model No.	Inventory No.	Cal Date	Cal Due Date
DC Power Supply	Chroma	62012P-80-60	SEM011-11	2023-10-19	2024-10-18
MXA Signal Analyzer	KEYSIGHT	N9020A	SEM004-19	2023-03-21	2024-03-20
Signal Generator	KEYSIGHT	N5173B	SEM006-05	2023-09-19	2024-09-18
Measurement Software	TST PASS	TST PASS V2.0	N/A	N/A	N/A
Coaxial Cable	SGS	N/A	SEM031-01	2023-07-07	2024-07-06
Attenuator	Huber+Suhner	6620_SMA-50-1	SEM021-09	2023-03-31	2024-03-30
Programmable Temperature & Humidity Chamber	Votsch Industrietechnik GmbH	VT 4002	SEM002-15	2023-03-21	2024-03-20

**Radiated Emissions (Below 1GHz)**

Equipment	Manufacturer	Model No.	Inventory No.	Cal Date	Cal Due Date
Loop Antenna	ETS-Lindgren	6502	SEM003-08	2023-11-20	2025-11-19
3m Semi-Anechoic Chamber	ETS-LINDGREN	N/A	SEM001-01	2023-06-19	2026-06-18
MXE EMI Receiver	Agilent Technologies	N9038A	SEM004-15	2023-10-19	2024-10-18
BiConiLog Antenna	ETS-LINDGREN	3142C	SEM003-01	2023-09-16	2025-09-15
Pre-Amplifier	Agilent Technologies	8447D	SEM005-01	2023-03-20	2024-03-19
Measurement Software	AUDIX	e3 V8.2014-6-27	N/A	N/A	N/A
Coaxial Cable	SGS	N/A	SEM025-01	2023-07-07	2024-07-06

**Radiated Emissions (Above 1GHz)**

Equipment	Manufacturer	Model No.	Inventory No.	Cal Date	Cal Due Date
3m Fully-Anechoic Chamber	AUDIX	N/A	SEM001-02	2023-04-01	2026-03-31
Signal Analyzer	Rohde & Schwarz	FSV40	SEM008-04	2023-03-20	2024-03-19
Horn Antenna	Rohde&Schwarz	HF907	SEM003-07	2023-07-23	2025-07-22
Microwave system amplifier	Agilent	83017A	SEM005-25	2023-09-19	2024-09-18
Measurement Software	AUDIX	e3 V8.2014-6-27	N/A	N/A	N/A
Coaxial Cable	SGS	N/A	SEM026-01	2023-07-07	2024-07-06



Unless otherwise agreed in writing, this document is issued by the Company subject to its General Conditions of Service printed overleaf, available on request or accessible at <https://www.sgs.com/en/Terms-and-Conditions>. Attention is drawn to the limitation of liability, indemnification and jurisdiction issues defined therein. Any holder of this document is advised that information contained herein reflects the Company's findings at the time of its intervention only and within the limits of Client's instructions, if any. The Company's sole responsibility is to its Client and this document does not exonerate parties to a transaction from exercising all their rights and obligations under the transaction documents. This document cannot be reproduced except in full, without prior written approval of the Company. Any unauthorized alteration, forgery or falsification of the content or appearance of this document is unlawful and offenders may be prosecuted to the fullest extent of the law. Unless otherwise stated the results shown in this test report refer only to the sample(s) tested and such sample(s) are retained for 30 days only.

Attention: To check the authenticity of testing /inspection report & certificate, please contact us at telephone: (86-755) 8307 1443, or email: CN.Doccheck@sgs.com

SGS-CSTC Standards Technical Services Co., Ltd. Shenzhen Branch  
 No.1 Workshop, M-10, Middle Section, Science & Technology Park, Nanshan District, Shenzhen, Guangdong, China 518057 t (86-755) 26012053 f (86-755) 26710594 www.sgs.com.cn  
 中国·广东·深圳市南山区科技园中区M-10栋1号厂房 邮编: 518057 t (86-755) 26012053 f (86-755) 26710594 sgs.china@sgs.com



Broad-Band Horn Antenna	Schwarzbeck	BBHA 9170	SEM003-15	2022-08-10	2024-08-09
Pre-Amplifier	Compliance Directions Systems Inc.	PAP-2640-50	SEM005-08	2023-03-20	2024-03-19

**Radiated Emissions which fall in the restricted bands**

Equipment	Manufacturer	Model No.	Inventory No.	Cal Date	Cal Due Date
3m Fully-Anechoic Chamber	AUDIX	N/A	SEM001-02	2023-04-01	2026-03-31
Signal Analyzer	Rohde & Schwarz	FSV40	SEM008-04	2023-03-20	2024-03-19
Horn Antenna	Rohde&Schwarz	HF907	SEM003-07	2023-07-23	2025-07-22
Microwave system amplifier	Agilent	83017A	SEM005-25	2023-09-19	2024-09-18
Measurement Software	AUDIX	e3 V8.2014-6-27	N/A	N/A	N/A
Coaxial Cable	SGS	N/A	SEM026-01	2023-07-07	2024-07-06

**Contention-based Protocol**

Equipment	Manufacturer	Model No.	Inventory No.	Cal Date	Cal Due Date
Shielding Room	AUDIX	N/A	SEM001-08	2022-05-14	2025-05-13
EXA Signal Analyzer	KEYSIGHT	N9010A	SEM004-09	2023-03-31	2024-03-30
Signal Generator	KEYSIGHT	N5171B	SEM006-13	2023-03-20	2024-03-19
MXG Vector Signal Generator	KEYSIGHT	N5182A	SEM006-14	2023-03-20	2024-03-19
ESG Vector Signal Generator	KEYSIGHT	E4438C	SEM006-15	2023-09-19	2024-09-18
DC Power Supply	KEYSIGHT	E3642A	SEM011-07	2023-03-21	2024-03-20
Manual Step Attenuator	KEYSIGHT	8494B	SEM021-05	2023-03-31	2024-03-30
Manual Step Attenuator	KEYSIGHT	8496B	SEM021-06	2023-03-31	2024-03-30
Power Sensor	TST PASS	TSPS2023R	SEM009-26	2023-04-01	2024-03-31
Power Sensor	TST PASS	TSPS2023R	SEM009-27	2023-04-01	2024-03-31
Power Sensor	TST PASS	TSPS2023R	SEM009-28	2023-04-01	2024-03-31
Power Sensor	TST PASS	TSPS2023R	SEM009-29	2023-04-01	2024-03-31
Measurement Software	TST PASS	TST PASS V2.0	N/A	N/A	N/A
Coaxial Cable	SGS	N/A	SEM028-01	2023-07-07	2024-07-06



Unless otherwise agreed in writing, this document is issued by the Company subject to its General Conditions of Service printed overleaf, available on request or accessible at <https://www.sgs.com/en/Terms-and-Conditions>. Attention is drawn to the limitation of liability, indemnification and jurisdiction issues defined therein. Any holder of this document is advised that information contained herein reflects the Company's findings at the time of its intervention only and within the limits of Client's instructions, if any. The Company's sole responsibility is to its Client and this document does not exonerate parties to a transaction from exercising all their rights and obligations under the transaction documents. This document cannot be reproduced except in full, without prior written approval of the Company. Any unauthorized alteration, forgery or falsification of the content or appearance of this document is unlawful and offenders may be prosecuted to the fullest extent of the law. Unless otherwise stated the results shown in this test report refer only to the sample(s) tested and such sample(s) are retained for 30 days only.

Attention: To check the authenticity of testing /inspection report & certificate, please contact us at telephone: (86-755) 8307 1443, or email: CN.Doccheck@sgs.com  
 No.1 Workshop, M-10, Middle Section, Science & Technology Park, Nanshan District, Shenzhen, Guangdong, China 518057 t (86-755) 26012053 f (86-755) 26710594 www.sgs.com.cn  
 中国·广东·深圳市南山区科技园中区M-10栋1号厂房 邮编: 518057 t (86-755) 26012053 f (86-755) 26710594 sgs.china@sgs.com



# SGS-CSTC Standards Technical Services Co., Ltd. Shenzhen Branch

SZEMC-TRF-01 Rev. A/1

Report No.: SZCR240100038407

Page: 13 of 424

Frequency Stability					
Equipment	Manufacturer	Model No.	Inventory No.	Cal Date	Cal Due Date
DC Power Supply	Chroma	62012P-80-60	SEM011-11	2023-10-19	2024-10-18
MXA Signal Analyzer	KEYSIGHT	N9020A	SEM004-19	2023-03-21	2024-03-20
Signal Generator	KEYSIGHT	N5173B	SEM006-05	2023-09-19	2024-09-18
Measurement Software	TST PASS	TST PASS V2.0	N/A	N/A	N/A
Coaxial Cable	SGS	N/A	SEM031-01	2023-07-07	2024-07-06
Attenuator	Huber+Suhner	6620_SMA-50-1	SEM021-09	2023-03-31	2024-03-30
Programmable Temperature & Humidity Chamber	Votsch Industrietechnik GmbH	VT 4002	SEM002-15	2023-03-21	2024-03-20

General used equipment					
Equipment	Manufacturer	Model No.	Inventory No.	Cal Date	Cal Due Date
Humidity/ Temperature Indicator	deli	8838	SEM002-32	2023-07-28	2024-07-27
Humidity/ Temperature Indicator	deli	8838	SEM002-33	2023-07-28	2024-07-27
Barometer	Changchun Meteorological Industry Factory	DYM3	SEM002-01	2023-03-23	2024-03-22



Unless otherwise agreed in writing, this document is issued by the Company subject to its General Conditions of Service printed overleaf, available on request or accessible at <https://www.sgs.com/en/Terms-and-Conditions>. Attention is drawn to the limitation of liability, indemnification and jurisdiction issues defined therein. Any holder of this document is advised that information contained hereon reflects the Company's findings at the time of its intervention only and within the limits of Client's instructions, if any. The Company's sole responsibility is to its Client and this document does not exonerate parties to a transaction from exercising all their rights and obligations under the transaction documents. This document cannot be reproduced except in full, without prior written approval of the Company. Any unauthorized alteration, forgery or falsification of the content or appearance of this document is unlawful and offenders may be prosecuted to the fullest extent of the law. Unless otherwise stated the results shown in this test report refer only to the sample(s) tested and such sample(s) are retained for 30 days only.

Attention: To check the authenticity of testing /inspection report & certificate, please contact us at telephone: (86-755) 8307 1443, or email: CN.Doccheck@sgs.com

## 6 Radio Spectrum Technical Requirement

### 6.1 Antenna Requirement

#### 6.1.1 Test Requirement:

47 CFR Part 15, Subpart C 15.203

#### 6.1.2 Conclusion

15.203 requirement:

An intentional radiator shall be designed to ensure that no antenna other than that furnished by the responsible party shall be used with the device. The use of a permanently attached antenna or of an antenna that uses a unique coupling to the intentional radiator, the manufacturer may design the unit so that a broken antenna can be replaced by the user, but the use of a standard antenna jack or electrical connector is prohibited.

EUT Antenna:

The antenna is an integrated antenna, and the connection port is fixed with glue, and the antenna cannot be replaced.

The best case gain of the antenna is

5925 MHz ~ 6425 MHz: 1.6dBi(Ant5); 1.6dBi(Ant6)\*

6425 MHz ~ 6525 MHz: 1.6dBi(Ant5); 1.6dBi(Ant6)\*

6525 MHz ~ 6875 MHz: 1.6dBi(Ant5); 1.6dBi(Ant6)\*

6875 MHz ~ 7125 MHz: 1.6dBi(Ant5); 1.6dBi(Ant6)\*

\*Note:

*The antenna gain are derived from the gain information report provided by the manufacturer.*

Remark:

*As above information is provided and confirmed by the applicant. SGS is not liable to the accuracy, suitability, reliability or/and integrity of the information.*

**Cyclic Delay Diversity (CDD) System:**

FCC KDB 662911 D01 Multiple Transmitter Output v02r01

If all antennas have the same gain,  $G_{ANT}$ , Directional gain =  $G_{ANT}$  + Array Gain, where Array Gain is as follows.

- For power spectral density (PSD) measurements on all devices,

$$Array\ Gain = 10 \log(N_{ANT}/N_{SS}=1) \text{ dB.}$$

- For power measurements on IEEE 802.11 devices:

$$Array\ Gain = 0 \text{ dB (i.e., no array gain) for } N_{ANT} \leq 4;$$

Directional gain may be calculated by using the formulas applicable to equal gain antennas with  $G_{ANT}$  set equal to the gain of the antenna having the highest gain.

**The Power and PSD limit should be modified if the directional gain of eut is over 6dbi.**

The EUT supports CDD System.

All antennas have the same gain:

Operation Frequency	ANT Gain5 (dBi)	ANT Gain6 (dBi)	Directional gain For Power (dBi)	Directional gain For PSD (dBi)
5925 MHz to 6425 MHz	1.6	1.6	1.6	4.61
6425 MHz to 6525 MHz	1.6	1.6	1.6	4.61
6525 MHz to 6875 MHz	1.6	1.6	1.6	4.61
6875 MHz to 7125 MHz	1.6	1.6	1.6	4.61

5925 MHz to 6425 MHz:

Power Limit Reduction = Directional gain – 6dBi, (Directional gain < 6dBi) =0

PSD Limit Reduction = Directional gain – 6dBi, (Directional gain < 6dBi) =0

6425 MHz to 6525 MHz:

Power Limit Reduction = Directional gain – 6dBi, (Directional gain < 6dBi) =0

PSD Limit Reduction = Directional gain – 6dBi, (Directional gain < 6dBi) =0

6525 MHz to 6875 MHz:

Power Limit Reduction = Directional gain – 6dBi, (Directional gain < 6dBi) =0

PSD Limit Reduction = Directional gain – 6dBi, (Directional gain < 6dBi) =0

6875 MHz to 7125 MHz:

Power Limit Reduction = Directional gain – 6dBi, (Directional gain < 6dBi) =0

PSD Limit Reduction = Directional gain – 6dBi, (Directional gain < 6dBi) =0



Unless otherwise agreed in writing, this document is issued by the Company subject to its General Conditions of Service printed overleaf, available on request or accessible at <https://www.sgs.com/en/Terms-and-Conditions>. Attention is drawn to the limitation of liability, indemnification and jurisdiction issues defined therein. Any holder of this document is advised that information contained hereon reflects the Company's findings at the time of its intervention only and within the limits of Client's instructions, if any. The Company's sole responsibility is to its Client and this document does not exonerate parties to a transaction from exercising all their rights and obligations under the transaction documents. This document cannot be reproduced except in full, without prior written approval of the Company. Any unauthorized alteration, forgery or falsification of the content or appearance of this document is unlawful and offenders may be prosecuted to the fullest extent of the law. Unless otherwise stated the results shown in this test report refer only to the sample(s) tested and such sample(s) are retained for 30 days only.

Attention: To check the authenticity of testing /inspection report & certificate, please contact us at telephone: (86-755) 8307 1443, or email: CN.Doccheck@sgs.com  
 No.1 Workshop, M-10, Middle Section, Science & Technology Park, Nanshan District, Shenzhen, Guangdong, China 518057 t (86-755) 26012053 f (86-755) 26710594 www.sgs.com.cn  
 中国·广东·深圳市南山区科技园中区M-10栋1号厂房 邮编: 518057 t (86-755) 26012053 f (86-755) 26710594 sgs.china@sgs.com

## 6.2 Transmission in the Absence of Data

### 6.2.1 Test Requirement:

47 CFR Part 15, Subpart E 15.407 (c)

### 6.2.2 Conclusion

Standard Requirement:

The device shall automatically discontinue transmission in case of either absence of information to transmit or operational failure. These provisions are not intended to preclude the transmission of control or signalling information or the use of repetitive codes used by certain digital technologies to complete frame or burst intervals.

Applicants shall include in their application for equipment authorization a description of how this requirement is met.

EUT Details:

WIFI chip support automatically discontinue transmission in case of either absence of information to transmit or operational failure, if the chip detect absence of information to transmit or operational failure, it will be automatically shut off.





## 7 Radio Spectrum Matter Test Results

### 7.1 Conducted Emissions at AC Power Line (150kHz-30MHz)

Test Requirement 47 CFR Part 15, Subpart C 15.207 & Subpart E 15.407 (b)(9)  
 Test Method: ANSI C63.10 (2020) Section 6.2

Limit:

Frequency of emission(MHz)	Conducted limit(dB $\mu$ V)	
	Quasi-peak	Average
0.15-0.5	66 to 56*	56 to 46*
0.5-5	56	46
5-30	60	50

\*Decreases with the logarithm of the frequency.

#### 7.1.1 E.U.T. Operation

Operating Environment:

Temperature: 23.4 °C Humidity: 47.3 % RH Atmospheric Pressure: 1000 mbar

#### 7.1.2 Test Mode Description

Pre-scan / Final test	Mode Code	Description
Final test	01	TX mode (U-NII-5) _Keep the EUT in continuously transmitting mode with all modulation types. All data rates for each modulation type have been tested and found the data rate @ MCS0 is the worst case of IEEE 802.11a/ax 20/40/80/160, Only the data of worst case is recorded in the report.



Unless otherwise agreed in writing, this document is issued by the Company subject to its General Conditions of Service printed overleaf, available on request or accessible at <https://www.sgs.com/en/Terms-and-Conditions>. Attention is drawn to the limitation of liability, indemnification and jurisdiction issues defined therein. Any holder of this document is advised that information contained hereon reflects the Company's findings at the time of its intervention only and within the limits of Client's instructions, if any. The Company's sole responsibility is to its Client and this document does not exonerate parties to a transaction from exercising all their rights and obligations under the transaction documents. This document cannot be reproduced except in full, without prior written approval of the Company. Any unauthorized alteration, forgery or falsification of the content or appearance of this document is unlawful and offenders may be prosecuted to the fullest extent of the law. Unless otherwise stated the results shown in this test report refer only to the sample(s) tested and such sample(s) are retained for 30 days only.

Attention: To check the authenticity of testing /inspection report & certificate, please contact us at telephone: (86-755) 8307 1443, or email: CN.Doccheck@sgs.com  
 No.1 Workshop, M-10, Middle Section, Science & Technology Park, Nanshan District, Shenzhen, Guangdong, China 518057 t (86-755) 26012053 f (86-755) 26710594 www.sgs.com.cn  
 中国·广东·深圳市南山区科技园中区M-10栋1号厂房 邮编: 518057 t (86-755) 26012053 f (86-755) 26710594 sgs.china@sgs.com

**7.1.3 Test Setup Diagram**

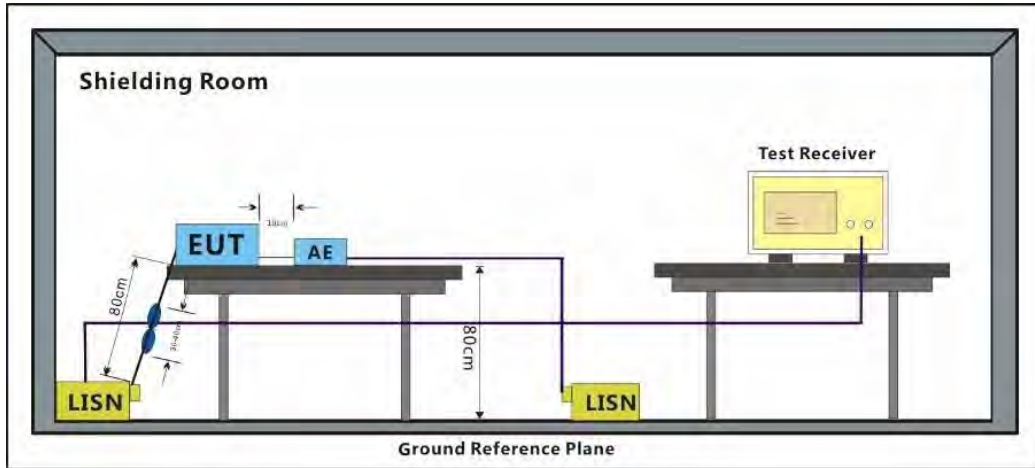

**7.1.4 Measurement Procedure and Data**

- 1) The mains terminal disturbance voltage test was conducted in a shielded room.
- 2) The EUT was connected to AC power source through a LISN 1 (Line Impedance Stabilization Network) which provides a 50ohm/50μH + 5ohm linear impedance. The power cables of all other units of the EUT were connected to a second LISN 2, which was bonded to the ground reference plane in the same way as the LISN 1 for the unit being measured. A multiple socket outlet strip was used to connect multiple power cables to a single LISN provided the rating of the LISN was not exceeded.
- 3) The tabletop EUT was placed upon a non-metallic table 0.8m above the ground reference plane. And for floor-standing arrangement, the EUT was placed on the horizontal ground reference plane,
- 4) The test was performed with a vertical ground reference plane. The rear of the EUT shall be 0.4 m from the vertical ground reference plane. The vertical ground reference plane was bonded to the horizontal ground reference plane. The LISN 1 was placed 0.8 m from the boundary of the unit under test and bonded to a ground reference plane for LISNs mounted on top of the ground reference plane. This distance was between the closest points of the LISN 1 and the EUT. All other units of the EUT and associated equipment was at least 0.8 m from the LISN 2.
- 5) In order to find the maximum emission, the relative positions of equipment and all of the interface cables must be changed according to ANSI C63.10 on conducted measurement.

Remark: Level=Read Level+ Cable Loss+ LISN Factor



Test Mode: 01; Line: Live line

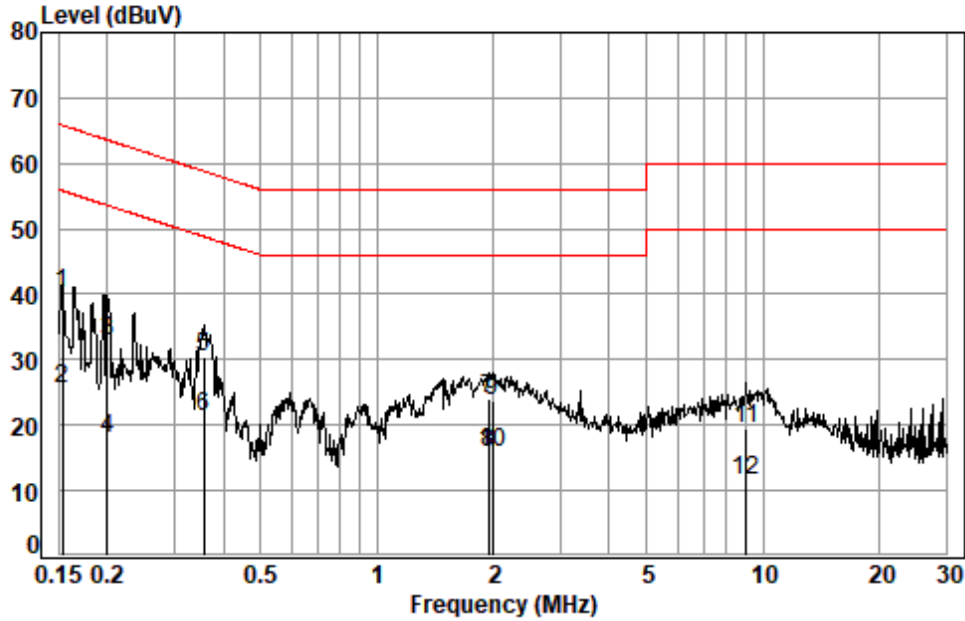

Site : Shielding Room  
 Condition: Line  
 Job No. : 00384AT  
 Test mode: 01

	Cable	LISN	Read	Limit	Over	
Freq	Loss	Factor	Level	Line	Limit	Remark
MHz	dB	dB	dBuV	dBuV	dBuV	dB
1 *	0.02	9.48	30.74	40.24	65.82	-25.58 QP
2	0.02	9.48	16.15	25.65	55.82	-30.17 Average
3	0.02	9.47	23.23	32.72	63.58	-30.86 QP
4	0.02	9.47	8.40	17.89	53.58	-35.69 Average
5	0.03	9.54	20.80	30.37	58.83	-28.46 QP
6 *	0.03	9.54	11.83	21.40	48.83	-27.43 Average
7	0.07	9.46	14.36	23.89	56.00	-32.11 QP
8	0.07	9.46	6.35	15.88	46.00	-30.12 Average
9	0.07	9.46	14.16	23.69	56.00	-32.31 QP
10	0.07	9.46	6.28	15.81	46.00	-30.19 Average
11	0.15	9.90	9.29	19.34	60.00	-40.66 QP
12	0.15	9.90	1.47	11.52	50.00	-38.48 Average



Unless otherwise agreed in writing, this document is issued by the Company subject to its General Conditions of Service printed overleaf, available on request or accessible at <https://www.sgs.com/en/Terms-and-Conditions>. Attention is drawn to the limitation of liability, indemnification and jurisdiction issues defined therein. Any holder of this document is advised that information contained hereon reflects the Company's findings at the time of its intervention only and within the limits of Client's instructions, if any. The Company's sole responsibility is to its Client and this document does not exonerate parties to a transaction from exercising all their rights and obligations under the transaction documents. This document cannot be reproduced except in full, without prior written approval of the Company. Any unauthorized alteration, forgery or falsification of the content or appearance of this document is unlawful and offenders may be prosecuted to the fullest extent of the law. Unless otherwise stated the results shown in this test report refer only to the sample(s) tested and such sample(s) are retained for 30 days only.

Attention: To check the authenticity of testing /inspection report & certificate, please contact us at telephone: (86-755) 8307 1443, or email: [CN.Doccheck@sgs.com](mailto:CN.Doccheck@sgs.com)  
 No.1 Workshop, M-10, Middle Section, Science & Technology Park, Nanshan District, Shenzhen, Guangdong, China 518057 t (86-755) 26012053 f (86-755) 26710594 www.sgs.com.cn  
 中国·广东·深圳市南山区科技园中区M-10栋1号厂房 邮编: 518057 t (86-755) 26012053 f (86-755) 26710594 sgs.china@sgs.com



Test Mode: 01; Line: Neutral Line

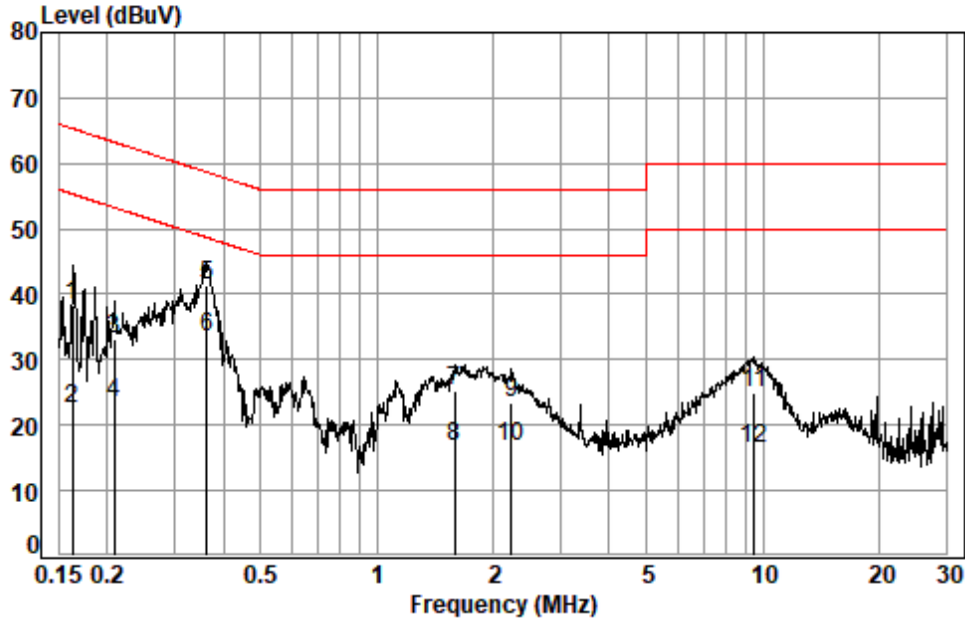

Site : Shielding Room  
 Condition: Neutral  
 Job No. : 00384AT  
 Test mode: 01

	Cable	LISN	Read	Limit	Over	
Freq	Loss	Factor	Level	Line	Limit	Remark
MHz	dB	dB	dBuV	dBuV	dBuV	dB
1	0.1624	0.02	9.64	28.55	38.21	65.34 -27.13 QP
2	0.1624	0.02	9.64	12.71	22.37	55.34 -32.97 Average
3	0.2083	0.02	9.66	23.54	33.22	63.27 -30.05 QP
4	0.2083	0.02	9.66	13.61	23.29	53.27 -29.98 Average
5 *	0.3634	0.03	9.72	31.49	41.24	58.65 -17.41 QP
6 *	0.3634	0.03	9.72	23.76	33.51	48.65 -15.14 Average
7	1.5935	0.06	9.74	15.35	25.15	56.00 -30.85 QP
8	1.5935	0.06	9.74	6.94	16.74	46.00 -29.26 Average
9	2.2367	0.07	9.71	13.69	23.47	56.00 -32.53 QP
10	2.2367	0.07	9.71	6.95	16.73	46.00 -29.27 Average
11	9.5016	0.16	10.10	14.64	24.90	60.00 -35.10 QP
12	9.5016	0.16	10.10	6.09	16.35	50.00 -33.65 Average



Unless otherwise agreed in writing, this document is issued by the Company subject to its General Conditions of Service printed overleaf, available on request or accessible at <https://www.sgs.com/en/Terms-and-Conditions>. Attention is drawn to the limitation of liability, indemnification and jurisdiction issues defined therein. Any holder of this document is advised that information contained hereon reflects the Company's findings at the time of its intervention only and within the limits of Client's instructions, if any. The Company's sole responsibility is to its Client and this document does not exonerate parties to a transaction from exercising all their rights and obligations under the transaction documents. This document cannot be reproduced except in full, without prior written approval of the Company. Any unauthorized alteration, forgery or falsification of the content or appearance of this document is unlawful and offenders may be prosecuted to the fullest extent of the law. Unless otherwise stated the results shown in this test report refer only to the sample(s) tested and such sample(s) are retained for 30 days only.



**7.2 Duty Cycle**

Test Requirement KDB 789033 D02 II B 1  
 Test Method: KDB 789033 II B 1

**7.2.1 E.U.T. Operation**

Operating Environment:  
 Temperature: 21.8 °C Humidity: 54.9 % RH Atmospheric Pressure: 1020 mbar

**7.2.2 Test Mode Description**

Pre-scan / Final test	Mode Code	Description
Final test	01	TX mode (U-NII-5) _ Keep the EUT in continuously transmitting mode with all modulation types. All data rates for each modulation type have been tested and found the data rate @ MCS0 is the worst case of IEEE 802.11a/ax 20/40/80/160, Only the data of worst case is recorded in the report.
Final test	02	TX mode (U-NII-6) _ Keep the EUT in continuously transmitting mode with all modulation types. All data rates for each modulation type have been tested and found the data rate @ MCS0 is the worst case of IEEE 802.11a/ax 20/40/80/160, Only the data of worst case is recorded in the report.
Final test	03	TX mode (U-NII-7) _ Keep the EUT in continuously transmitting mode with all modulation types. All data rates for each modulation type have been tested and found the data rate @ MCS0 is the worst case of IEEE 802.11a/ax 20/40/80/160, Only the data of worst case is recorded in the report.
Final test	04	TX mode (U-NII-8) _ Keep the EUT in continuously transmitting mode with all modulation types. All data rates for each modulation type have been tested and found the data rate @ MCS0 is the worst case of IEEE 802.11a/ax 20/40/80/160, Only the data of worst case is recorded in the report.

**7.2.3 Test Setup Diagram**

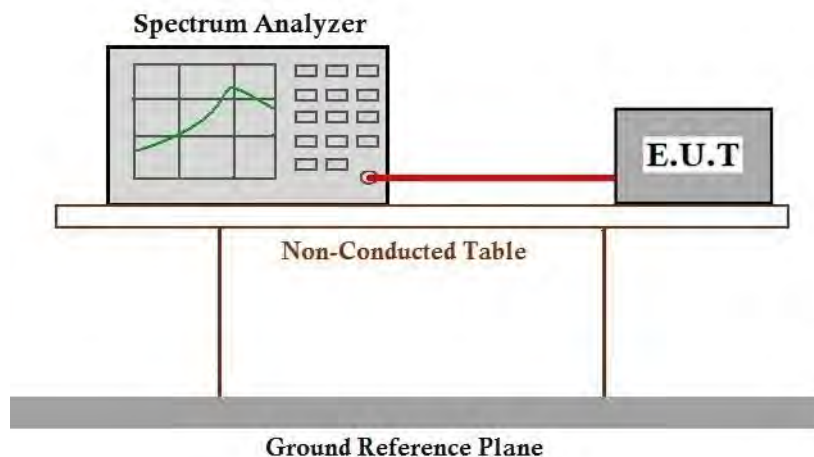

**7.2.4 Measurement Procedure and Data**

Please Refer to Appendix for Details



Unless otherwise agreed in writing, this document is issued by the Company subject to its General Conditions of Service printed overleaf, available on request or accessible at <https://www.sgs.com/en/Terms-and-Conditions>. Attention is drawn to the limitation of liability, indemnification and jurisdiction issues defined therein. Any holder of this document is advised that information contained hereon reflects the Company's findings at the time of its intervention only and within the limits of Client's instructions, if any. The Company's sole responsibility is to its Client and this document does not exonerate parties to a transaction from exercising all their rights and obligations under the transaction documents. This document cannot be reproduced except in full, without prior written approval of the Company. Any unauthorized alteration, forgery or falsification of the content or appearance of this document is unlawful and offenders may be prosecuted to the fullest extent of the law. Unless otherwise stated the results shown in this test report refer only to the sample(s) tested and such sample(s) are retained for 30 days only.  
 Attention: To check the authenticity of testing /inspection report & certificate, please contact us at telephone: (86-755) 8307 1443, or email: CN.Doccheck@sgs.com  
 No.1 Workshop, M-10, Middle Section, Science & Technology Park, Nanshan District, Shenzhen, Guangdong, China 518057 t (86-755) 26012053 f (86-755) 26710594 www.sgs.com.cn  
 中国·广东·深圳市南山区科技园中区M-10栋1号厂房 邮编: 518057 t (86-755) 26012053 f (86-755) 26710594 sgs.china@sgs.com

**7.3 99% Bandwidth**

Test Requirement 47 CFR Part 15, Subpart E 15.407 (a)(10)  
 Test Method: KDB 789033 II D

Limit:

The maximum transmitter channel bandwidth for U-NII devices in the 5.925–7.125 GHz band is 160MHz.

**7.3.1 E.U.T. Operation**

Operating Environment:

Temperature: 21.8 °C Humidity: 54.9 % RH Atmospheric Pressure: 1020 mbar

**7.3.2 Test Mode Description**

Pre-scan / Final test	Mode Code	Description
Final test	01	TX mode (U-NII-5) _ Keep the EUT in continuously transmitting mode with all modulation types. All data rates for each modulation type have been tested and found the data rate @ MCS0 is the worst case of IEEE 802.11a/ax 20/40/80/160, Only the data of worst case is recorded in the report.
Final test	02	TX mode (U-NII-6) _ Keep the EUT in continuously transmitting mode with all modulation types. All data rates for each modulation type have been tested and found the data rate @ MCS0 is the worst case of IEEE 802.11a/ax 20/40/80/160, Only the data of worst case is recorded in the report.
Final test	03	TX mode (U-NII-7) _ Keep the EUT in continuously transmitting mode with all modulation types. All data rates for each modulation type have been tested and found the data rate @ MCS0 is the worst case of IEEE 802.11a/ax 20/40/80/160, Only the data of worst case is recorded in the report.
Final test	04	TX mode (U-NII-8) _ Keep the EUT in continuously transmitting mode with all modulation types. All data rates for each modulation type have been tested and found the data rate @ MCS0 is the worst case of IEEE 802.11a/ax 20/40/80/160, Only the data of worst case is recorded in the report.

**7.3.3 Test Setup Diagram**

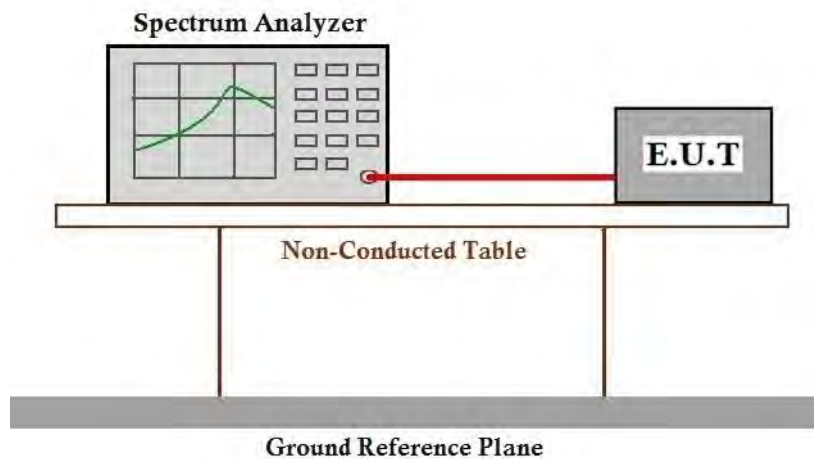

**7.3.4 Measurement Procedure and Data**

Please Refer to Appendix for Details



Unless otherwise agreed in writing, this document is issued by the Company subject to its General Conditions of Service printed overleaf, available on request or accessible at <https://www.sgs.com/en/Terms-and-Conditions>. Attention is drawn to the limitation of liability, indemnification and jurisdiction issues defined therein. Any holder of this document is advised that information contained hereon reflects the Company's findings at the time of its intervention only and within the limits of Client's instructions, if any. The Company's sole responsibility is to its Client and this document does not exonerate parties to a transaction from exercising all their rights and obligations under the transaction documents. This document cannot be reproduced except in full, without prior written approval of the Company. Any unauthorized alteration, forgery or falsification of the content or appearance of this document is unlawful and offenders may be prosecuted to the fullest extent of the law. Unless otherwise stated the results shown in this test report refer only to the sample(s) tested and such sample(s) are retained for 30 days only.  
 Attention: To check the authenticity of testing /inspection report & certificate, please contact us at telephone: (86-755) 8307 1443, or email: CN.Doccheck@sgs.com  
 No.1 Workshop, M-10, Middle Section, Science & Technology Park, Nanshan District, Shenzhen, Guangdong, China 518057 t (86-755) 26012053 f (86-755) 26710594 www.sgs.com.cn  
 中国·广东·深圳市南山区科技园中区M-10栋1号厂房 邮编: 518057 t (86-755) 26012053 f (86-755) 26710594 sgs.china@sgs.com

**7.4 26dB Emission bandwidth**

Test Requirement 47 CFR Part 15, Subpart E 15.407 (a)  
 Test Method: KDB 789033 D02 II C 1

**7.4.1 E.U.T. Operation**

Operating Environment:  
 Temperature: 21.8 °C Humidity: 54.9 % RH Atmospheric Pressure: 1020 mbar

**7.4.2 Test Mode Description**

Pre-scan / Final test	Mode Code	Description
Final test	01	TX mode (U-NII-5) _ Keep the EUT in continuously transmitting mode with all modulation types. All data rates for each modulation type have been tested and found the data rate @ MCS0 is the worst case of IEEE 802.11a/ax 20/40/80/160, Only the data of worst case is recorded in the report.
Final test	02	TX mode (U-NII-6) _ Keep the EUT in continuously transmitting mode with all modulation types. All data rates for each modulation type have been tested and found the data rate @ MCS0 is the worst case of IEEE 802.11a/ax 20/40/80/160, Only the data of worst case is recorded in the report.
Final test	03	TX mode (U-NII-7) _ Keep the EUT in continuously transmitting mode with all modulation types. All data rates for each modulation type have been tested and found the data rate @ MCS0 is the worst case of IEEE 802.11a/ax 20/40/80/160, Only the data of worst case is recorded in the report.
Final test	04	TX mode (U-NII-8) _ Keep the EUT in continuously transmitting mode with all modulation types. All data rates for each modulation type have been tested and found the data rate @ MCS0 is the worst case of IEEE 802.11a/ax 20/40/80/160, Only the data of worst case is recorded in the report.

**7.4.3 Test Setup Diagram**

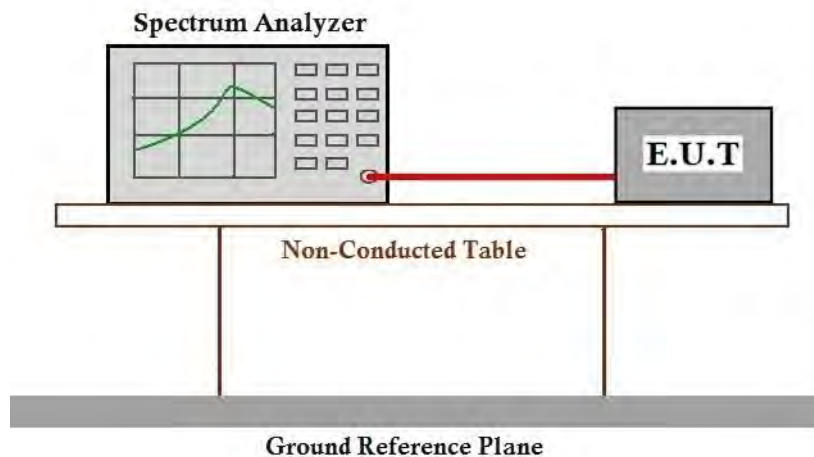

**7.4.4 Measurement Procedure and Data**

Please Refer to Appendix for Details



Unless otherwise agreed in writing, this document is issued by the Company subject to its General Conditions of Service printed overleaf, available on request or accessible at <https://www.sgs.com/en/Terms-and-Conditions>. Attention is drawn to the limitation of liability, indemnification and jurisdiction issues defined therein. Any holder of this document is advised that information contained hereon reflects the Company's findings at the time of its intervention only and within the limits of Client's instructions, if any. The Company's sole responsibility is to its Client and this document does not exonerate parties to a transaction from exercising all their rights and obligations under the transaction documents. This document cannot be reproduced except in full, without prior written approval of the Company. Any unauthorized alteration, forgery or falsification of the content or appearance of this document is unlawful and offenders may be prosecuted to the fullest extent of the law. Unless otherwise stated the results shown in this test report refer only to the sample(s) tested and such sample(s) are retained for 30 days only.  
 Attention: To check the authenticity of testing /inspection report & certificate, please contact us at telephone: (86-755) 8307 1443, or email: CN.Doccheck@sgs.com  
 No.1 Workshop, M-10, Middle Section, Science & Technology Park, Nanshan District, Shenzhen, Guangdong, China 518057 t (86-755) 26012053 f (86-755) 26710594 www.sgs.com.cn  
 中国·广东·深圳市南山区科技园中区M-10栋1号厂房 邮编: 518057 t (86-755) 26012053 f (86-755) 26710594 sgs.china@sgs.com



**7.5 Maximum e.i.r.p**

Test Requirement 47 CFR Part 15, Subpart E 15.407 (a)(5)  
 Test Method: KDB 789033 D02 II E

Limit:

For an indoor access point operating in the 5.925–7.125 GHz band, the maximum power spectral density must not exceed 5 dBm e.i.r.p. in any 1-megahertz band. In addition, the maximum e.i.r.p. over the frequency band of operation must not exceed 30 dBm.

**7.5.1 E.U.T. Operation**

Operating Environment:

Temperature: 21.8 °C Humidity: 54.9 % RH Atmospheric Pressure: 1020 mbar

**7.5.2 Test Mode Description**

Pre-scan / Final test	Mode Code	Description
Final test	01	TX mode (U-NII-5) _ Keep the EUT in continuously transmitting mode with all modulation types. All data rates for each modulation type have been tested and found the data rate @ MCS0 is the worst case of IEEE 802.11a/ax 20/40/80/160, Only the data of worst case is recorded in the report.
Final test	02	TX mode (U-NII-6) _ Keep the EUT in continuously transmitting mode with all modulation types. All data rates for each modulation type have been tested and found the data rate @ MCS0 is the worst case of IEEE 802.11a/ax 20/40/80/160, Only the data of worst case is recorded in the report.
Final test	03	TX mode (U-NII-7) _ Keep the EUT in continuously transmitting mode with all modulation types. All data rates for each modulation type have been tested and found the data rate @ MCS0 is the worst case of IEEE 802.11a/ax 20/40/80/160, Only the data of worst case is recorded in the report.
Final test	04	TX mode (U-NII-8) _ Keep the EUT in continuously transmitting mode with all modulation types. All data rates for each modulation type have been tested and found the data rate @ MCS0 is the worst case of IEEE 802.11a/ax 20/40/80/160, Only the data of worst case is recorded in the report.



Unless otherwise agreed in writing, this document is issued by the Company subject to its General Conditions of Service printed overleaf, available on request or accessible at <https://www.sgs.com/en/Terms-and-Conditions>. Attention is drawn to the limitation of liability, indemnification and jurisdiction issues defined therein. Any holder of this document is advised that information contained hereon reflects the Company's findings at the time of its intervention only and within the limits of Client's instructions, if any. The Company's sole responsibility is to its Client and this document does not exonerate parties to a transaction from exercising all their rights and obligations under the transaction documents. This document cannot be reproduced except in full, without prior written approval of the Company. Any unauthorized alteration, forgery or falsification of the content or appearance of this document is unlawful and offenders may be prosecuted to the fullest extent of the law. Unless otherwise stated the results shown in this test report refer only to the sample(s) tested and such sample(s) are retained for 30 days only.

Attention: To check the authenticity of testing /inspection report & certificate, please contact us at telephone: (86-755) 8307 1443, or email: CN.Doccheck@sgs.com  
 No.1 Workshop, M-10, Middle Section, Science & Technology Park, Nanshan District, Shenzhen, Guangdong, China 518057 t (86-755) 26012053 f (86-755) 26710594 www.sgs.com.cn  
 中国·广东·深圳市南山区科技园中区M-10栋1号厂房 邮编: 518057 t (86-755) 26012053 f (86-755) 26710594 sgs.china@sgs.com

**7.5.3 Test Setup Diagram**

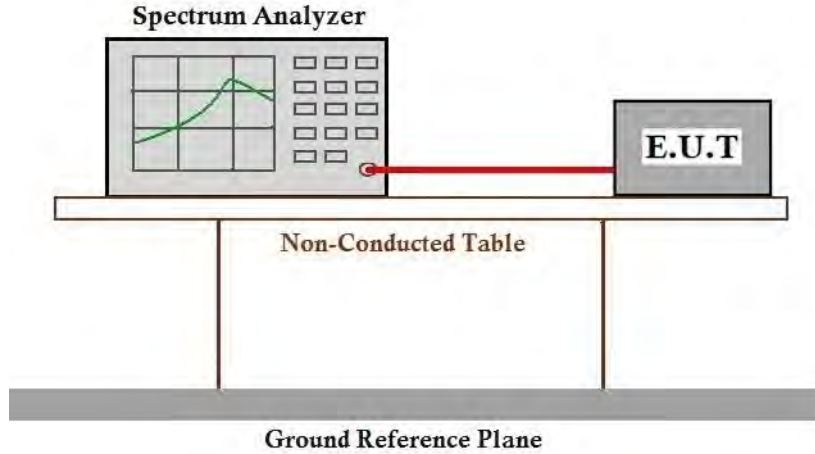

**7.5.4 Measurement Procedure and Data**

Note: Since the verify power the same operating range bandwidth and smaller power can be covered by the higher power.

Please Refer to Appendix for Details



**7.6 Maximum Power spectral density**

Test Requirement 47 CFR Part 15, Subpart E 15.407 (a)(5)  
 Test Method: KDB 789033 D02 II F

Limit:

For an indoor access point operating in the 5.925–7.125 GHz band, the maximum power spectral density must not exceed 5 dBm e.i.r.p. in any 1-megahertz band. In addition, the maximum e.i.r.p. over the frequency band of operation must not exceed 30 dBm.

**7.6.1 E.U.T. Operation**

Operating Environment:  
 Temperature: 21.8 °C Humidity: 54.9 % RH Atmospheric Pressure: 1020 mbar

**7.6.2 Test Mode Description**

Pre-scan / Final test	Mode Code	Description
Final test	01	TX mode (U-NII-5) _ Keep the EUT in continuously transmitting mode with all modulation types. All data rates for each modulation type have been tested and found the data rate @ MCS0 is the worst case of IEEE 802.11a/ax 20/40/80/160, Only the data of worst case is recorded in the report.
Final test	02	TX mode (U-NII-6) _ Keep the EUT in continuously transmitting mode with all modulation types. All data rates for each modulation type have been tested and found the data rate @ MCS0 is the worst case of IEEE 802.11a/ax 20/40/80/160, Only the data of worst case is recorded in the report.
Final test	03	TX mode (U-NII-7) _ Keep the EUT in continuously transmitting mode with all modulation types. All data rates for each modulation type have been tested and found the data rate @ MCS0 is the worst case of IEEE 802.11a/ax 20/40/80/160, Only the data of worst case is recorded in the report.
Final test	04	TX mode (U-NII-8) _ Keep the EUT in continuously transmitting mode with all modulation types. All data rates for each modulation type have been tested and found the data rate @ MCS0 is the worst case of IEEE 802.11a/ax 20/40/80/160, Only the data of worst case is recorded in the report.



Unless otherwise agreed in writing, this document is issued by the Company subject to its General Conditions of Service printed overleaf, available on request or accessible at <https://www.sgs.com/en/Terms-and-Conditions>. Attention is drawn to the limitation of liability, indemnification and jurisdiction issues defined therein. Any holder of this document is advised that information contained hereon reflects the Company's findings at the time of its intervention only and within the limits of Client's instructions, if any. The Company's sole responsibility is to its Client and this document does not exonerate parties to a transaction from exercising all their rights and obligations under the transaction documents. This document cannot be reproduced except in full, without prior written approval of the Company. Any unauthorized alteration, forgery or falsification of the content or appearance of this document is unlawful and offenders may be prosecuted to the fullest extent of the law. Unless otherwise stated the results shown in this test report refer only to the sample(s) tested and such sample(s) are retained for 30 days only.  
 Attention: To check the authenticity of testing /inspection report & certificate, please contact us at telephone: (86-755) 8307 1443, or email: CN.Doccheck@sgs.com  
 No.1 Workshop, M-10, Middle Section, Science & Technology Park, Nanshan District, Shenzhen, Guangdong, China 518057 t (86-755) 26012053 f (86-755) 26710594 www.sgs.com.cn  
 中国·广东·深圳市南山区科技园中区M-10栋1号厂房 邮编: 518057 t (86-755) 26012053 f (86-755) 26710594 sgs.china@sgs.com



**7.6.3 Test Setup Diagram**

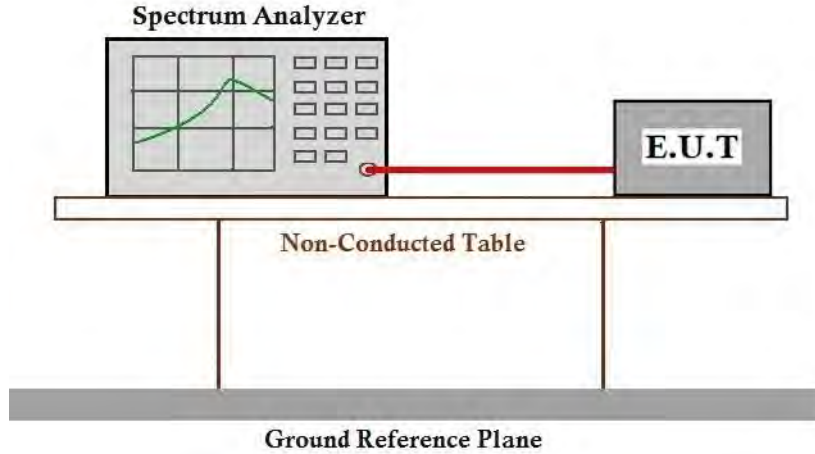

**7.6.4 Measurement Procedure and Data**

Please Refer to Appendix for Details



Unless otherwise agreed in writing, this document is issued by the Company subject to its General Conditions of Service printed overleaf, available on request or accessible at <https://www.sgs.com/en/Terms-and-Conditions>. Attention is drawn to the limitation of liability, indemnification and jurisdiction issues defined therein. Any holder of this document is advised that information contained hereon reflects the Company's findings at the time of its intervention only and within the limits of Client's instructions, if any. The Company's sole responsibility is to its Client and this document does not exonerate parties to a transaction from exercising all their rights and obligations under the transaction documents. This document cannot be reproduced except in full, without prior written approval of the Company. Any unauthorized alteration, forgery or falsification of the content or appearance of this document is unlawful and offenders may be prosecuted to the fullest extent of the law. Unless otherwise stated the results shown in this test report refer only to the sample(s) tested and such sample(s) are retained for 30 days only.

Attention: To check the authenticity of testing /inspection report & certificate, please contact us at telephone: (86-755) 8307 1443, or email: [CN.Doccheck@sgs.com](mailto:CN.Doccheck@sgs.com)  
 No.1 Workshop, M-10, Middle Section, Science & Technology Park, Nanshan District, Shenzhen, Guangdong, China 518057 t (86-755) 26012053 f (86-755) 26710594 www.sgs.com.cn  
 中国·广东·深圳市南山区科技园中区M-10栋1号厂房 邮编: 518057 t (86-755) 26012053 f (86-755) 26710594 sgs.china@sgs.com

**7.7 In-Band Emissions**

Test Requirement 47 CFR Part 15, Subpart E 15.407 (b)(7)  
 Test Method: KDB 987594 D02 U-NII 6GHz EMC Measurement v02r01

Limit:

For transmitters operating within the 5.925–7.125 GHz bands: Power spectral density must be suppressed by 20 dB at 1 MHz outside of channel edge, by 28 dB at one channel bandwidth from the channel center, and by 40 dB at one- and one-half times the channel bandwidth away from channel center. At frequencies between one megahertz outside an unlicensed device’s channel edge and one channel bandwidth from the center of the channel, the limits must be linearly interpolated between 20 dB and 28 dB suppression, and at frequencies between one and one- and one half times an unlicensed device’s channel bandwidth, the limits must be linearly interpolated between 28 dB and 40 dB suppression. Emissions removed from the channel center by more than one- and one-half times the channel bandwidth must be suppressed by at least 40 dB.

**7.7.1 E.U.T. Operation**

Operating Environment:  
 Temperature: 21.8 °C Humidity: 54.9 % RH Atmospheric Pressure: 1020 mbar

**7.7.2 Test Mode Description**

Pre-scan / Final test	Mode Code	Description
Final test	01	TX mode (U-NII-5) _ Keep the EUT in continuously transmitting mode with all modulation types. All data rates for each modulation type have been tested and found the data rate @ MCS0 is the worst case of IEEE 802.11a/ax 20/40/80/160, Only the data of worst case is recorded in the report.
Final test	02	TX mode (U-NII-6) _ Keep the EUT in continuously transmitting mode with all modulation types. All data rates for each modulation type have been tested and found the data rate @ MCS0 is the worst case of IEEE 802.11a/ax 20/40/80/160, Only the data of worst case is recorded in the report.
Final test	03	TX mode (U-NII-7) _ Keep the EUT in continuously transmitting mode with all modulation types. All data rates for each modulation type have been tested and found the data rate @ MCS0 is the worst case of IEEE 802.11a/ax 20/40/80/160, Only the data of worst case is recorded in the report.
Final test	04	TX mode (U-NII-8) _ Keep the EUT in continuously transmitting mode with all modulation types. All data rates for each modulation type have been tested and found the data rate @ MCS0 is the worst case of IEEE 802.11a/ax 20/40/80/160, Only the data of worst case is recorded in the report.



Unless otherwise agreed in writing, this document is issued by the Company subject to its General Conditions of Service printed overleaf, available on request or accessible at <https://www.sgs.com/en/Terms-and-Conditions>. Attention is drawn to the limitation of liability, indemnification and jurisdiction issues defined therein. Any holder of this document is advised that information contained hereon reflects the Company’s findings at the time of its intervention only and within the limits of Client’s instructions, if any. The Company’s sole responsibility is to its Client and this document does not exonerate parties to a transaction from exercising all their rights and obligations under the transaction documents. This document cannot be reproduced except in full, without prior written approval of the Company. Any unauthorized alteration, forgery or falsification of the content or appearance of this document is unlawful and offenders may be prosecuted to the fullest extent of the law. Unless otherwise stated the results shown in this test report refer only to the sample(s) tested and such sample(s) are retained for 30 days only.  
**Attention: To check the authenticity of testing /inspection report & certificate, please contact us at telephone: (86-755) 8307 1443, or email: CN.Doccheck@sgs.com**  
 No.1 Workshop, M-10, Middle Section, Science & Technology Park, Nanshan District, Shenzhen, Guangdong, China 518057 t (86-755) 26012053 f (86-755) 26710594 www.sgs.com.cn  
 中国·广东·深圳市南山区科技园中区M-10栋1号厂房 邮编: 518057 t (86-755) 26012053 f (86-755) 26710594 sgs.china@sgs.com

**7.7.3 Test Setup Diagram**

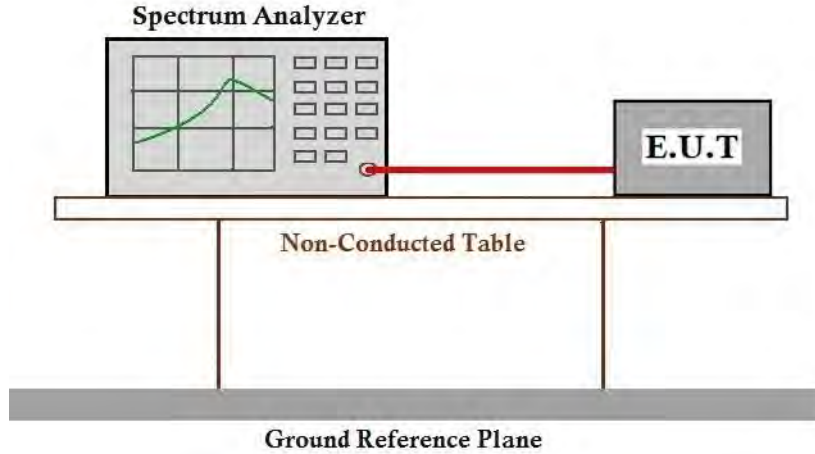

**7.7.4 Measurement Procedure and Data**

Please Refer to Appendix for Details



Unless otherwise agreed in writing, this document is issued by the Company subject to its General Conditions of Service printed overleaf, available on request or accessible at <https://www.sgs.com/en/Terms-and-Conditions>. Attention is drawn to the limitation of liability, indemnification and jurisdiction issues defined therein. Any holder of this document is advised that information contained hereon reflects the Company's findings at the time of its intervention only and within the limits of Client's instructions, if any. The Company's sole responsibility is to its Client and this document does not exonerate parties to a transaction from exercising all their rights and obligations under the transaction documents. This document cannot be reproduced except in full, without prior written approval of the Company. Any unauthorized alteration, forgery or falsification of the content or appearance of this document is unlawful and offenders may be prosecuted to the fullest extent of the law. Unless otherwise stated the results shown in this test report refer only to the sample(s) tested and such sample(s) are retained for 30 days only.

Attention: To check the authenticity of testing /inspection report & certificate, please contact us at telephone: (86-755) 8307 1443, or email: [CN.Doccheck@sgs.com](mailto:CN.Doccheck@sgs.com)  
 No.1 Workshop, M-10, Middle Section, Science & Technology Park, Nanshan District, Shenzhen, Guangdong, China 518057 t (86-755) 26012053 f (86-755) 26710594 www.sgs.com.cn  
 中国·广东·深圳市南山区科技园中区M-10栋1号厂房 邮编: 518057 t (86-755) 26012053 f (86-755) 26710594 sgs.china@sgs.com



**7.8 Radiated Emissions (Below 1GHz)**

Test Requirement 47 CFR Part 15, Subpart C 15.209 & Subpart E 15.407(b)  
 Test Method: KDB 789033 D02 II G  
 Measurement Distance: 3m

Limit:

Frequency(MHz)	Field strength(microvolts/meter)	Measurement distance(meters)
0.009-0.490	2400/F(kHz)	300
0.490-1.705	24000/F(kHz)	30
1.705-30.0	30	30
30-88	100	3
88-216	150	3
216-960	200	3
960-1000	500	3

**7.8.1 E.U.T. Operation**

Operating Environment:  
 Temperature: 23.6 °C Humidity: 49.5 % RH Atmospheric Pressure: 1000 mbar

**7.8.2 Test Mode Description**

Pre-scan / Final test	Mode Code	Description
Final test	01	TX mode (U-NII-5) _Keep the EUT in continuously transmitting mode with all modulation types. All data rates for each modulation type have been tested and found the data rate @ MCS0 is the worst case of IEEE 802.11a/ax 20/40/80/160, Only the data of worst case is recorded in the report.
Pre-scan	02	TX mode (U-NII-6) _ Keep the EUT in continuously transmitting mode with all modulation types. All data rates for each modulation type have been tested and found the data rate @ MCS0 is the worst case of IEEE 802.11a/ax 20/40/80/160, Only the data of worst case is recorded in the report.
Pre-scan	03	TX mode (U-NII-7) _ Keep the EUT in continuously transmitting mode with all modulation types. All data rates for each modulation type have been tested and found the data rate @ MCS0 is the worst case of IEEE 802.11a/ax 20/40/80/160, Only the data of worst case is recorded in the report.
Pre-scan	04	TX mode (U-NII-8) _ Keep the EUT in continuously transmitting mode with all modulation types. All data rates for each modulation type have been tested and found the data rate @ MCS0 is the worst case of IEEE 802.11a/ax 20/40/80/160, Only the data of worst case is recorded in the report.



Unless otherwise agreed in writing, this document is issued by the Company subject to its General Conditions of Service printed overleaf, available on request or accessible at <https://www.sgs.com/en/Terms-and-Conditions>. Attention is drawn to the limitation of liability, indemnification and jurisdiction issues defined therein. Any holder of this document is advised that information contained hereon reflects the Company's findings at the time of its intervention only and within the limits of Client's instructions, if any. The Company's sole responsibility is to its Client and this document does not exonerate parties to a transaction from exercising all their rights and obligations under the transaction documents. This document cannot be reproduced except in full, without prior written approval of the Company. Any unauthorized alteration, forgery or falsification of the content or appearance of this document is unlawful and offenders may be prosecuted to the fullest extent of the law. Unless otherwise stated the results shown in this test report refer only to the sample(s) tested and such sample(s) are retained for 30 days only.  
 Attention: To check the authenticity of testing /inspection report & certificate, please contact us at telephone: (86-755) 8307 1443, or email: CN.Doccheck@sgs.com  
 No.1 Workshop, M-10, Middle Section, Science & Technology Park, Nanshan District, Shenzhen, Guangdong, China 518057 t (86-755) 26012053 f (86-755) 26710594 www.sgs.com.cn  
 中国·广东·深圳市南山区科技园中区M-10栋1号厂房 邮编: 518057 t (86-755) 26012053 f (86-755) 26710594 sgs.china@sgs.com

**7.8.3 Test Setup Diagram**

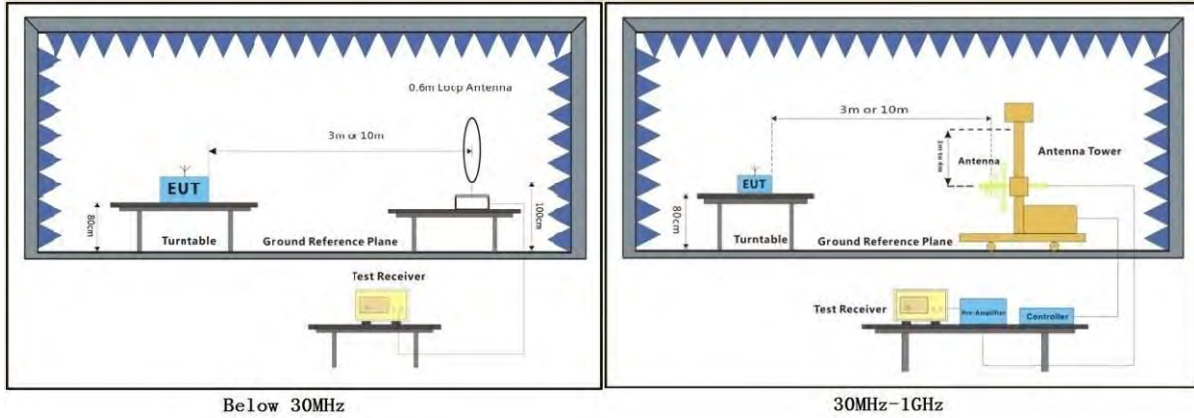

Below 30MHz

30MHz-1GHz



Unless otherwise agreed in writing, this document is issued by the Company subject to its General Conditions of Service printed overleaf, available on request or accessible at <https://www.sgs.com/en/Terms-and-Conditions>. Attention is drawn to the limitation of liability, indemnification and jurisdiction issues defined therein. Any holder of this document is advised that information contained hereon reflects the Company's findings at the time of its intervention only and within the limits of Client's instructions, if any. The Company's sole responsibility is to its Client and this document does not exonerate parties to a transaction from exercising all their rights and obligations under the transaction documents. This document cannot be reproduced except in full, without prior written approval of the Company. Any unauthorized alteration, forgery or falsification of the content or appearance of this document is unlawful and offenders may be prosecuted to the fullest extent of the law. Unless otherwise stated the results shown in this test report refer only to the sample(s) tested and such sample(s) are retained for 30 days only.

Attention: To check the authenticity of testing /inspection report & certificate, please contact us at telephone: (86-755) 8307 1443, or email: [CN.Doccheck@sgs.com](mailto:CN.Doccheck@sgs.com)

**7.8.4 Measurement Procedure and Data**

- a. For below 1GHz, the EUT was placed on the top of a rotating table 0.8 meters above the ground at a 3 meter semi-anechoic chamber. The table was rotated 360 degrees to determine the position of the highest radiation.
- b. The EUT was set 3 or 10 meters away from the interference-receiving antenna, which was mounted on the top of a variable-height antenna tower.
- c. The antenna height is varied from one meter to four meters above the ground to determine the maximum value of the field strength. Both horizontal and vertical polarizations of the antenna are set to make the measurement.
- d. For each suspected emission, the EUT was arranged to its worst case and then the antenna was tuned to heights from 1 meter to 4 meters (for the test frequency of below 30MHz, the antenna was tuned to heights 1 meter) and the rotatable table was turned from 0 degrees to 360 degrees to find the maximum reading.
- e. The test-receiver system was set to Peak Detect Function and Specified Bandwidth with Maximum Hold Mode.
- f. If the emission level of the EUT in peak mode was 10Db lower than the limit specified, then testing could be stopped and the peak values of the EUT would be reported. Otherwise the emissions that did not have 10Db margin would be re-tested one by one using quasi-peak method as specified and then reported in a data sheet.
- g. Test the EUT in the lowest channel, the middle channel, the Highest channel.
- h. The radiation measurements are performed in X, Y, Z axis positioning for Transmitting mode, and found the X axis positioning which it is the worst case.
- i. Repeat above procedures until all frequencies measured was complete.

Remark:

1. Level= Read Level+ Cable Loss+ Antenna Factor- Preamp Factor
2. For emission below 1GHz, through the pre-scan found the worst case is the lowest channel of 802.11a. Only the worst case is recorded in the report.
3. Scan from 9kHz to 30MHz, the disturbance below 30MHz was very low. The points marked on above plots are the highest emissions could be found when testing, so only above points had been displayed. The amplitude of spurious emissions from the radiator which are attenuated more than 20Db below the limit need not be reported.
4. The disturbance below 1GHz was very low and the harmonics were the highest point could be found when testing, so only the above harmonics had been displayed.



Unless otherwise agreed in writing, this document is issued by the Company subject to its General Conditions of Service printed overleaf, available on request or accessible at <https://www.sgs.com/en/Terms-and-Conditions>. Attention is drawn to the limitation of liability, indemnification and jurisdiction issues defined therein. Any holder of this document is advised that information contained hereon reflects the Company's findings at the time of its intervention only and within the limits of Client's instructions, if any. The Company's sole responsibility is to its Client and this document does not exonerate parties to a transaction from exercising all their rights and obligations under the transaction documents. This document cannot be reproduced except in full, without prior written approval of the Company. Any unauthorized alteration, forgery or falsification of the content or appearance of this document is unlawful and offenders may be prosecuted to the fullest extent of the law. Unless otherwise stated the results shown in this test report refer only to the sample(s) tested and such sample(s) are retained for 30 days only.

Attention: To check the authenticity of testing /inspection report & certificate, please contact us at telephone: (86-755) 8307 1443, or email: CN.Doccheck@sgs.com



Test Mode: 01; Polarity: Horizontal

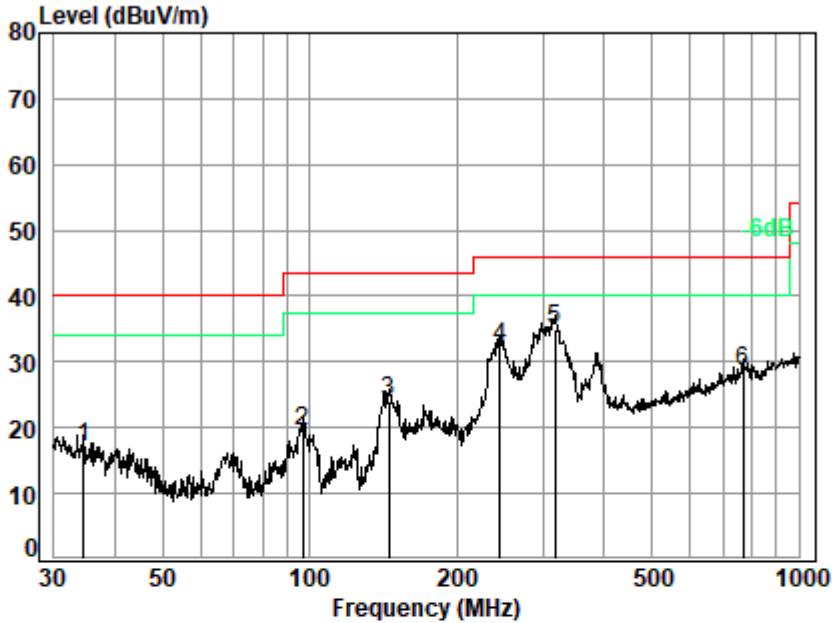

Site : chamber  
 Condition: 3m HORIZONTAL  
 Job No. : 00384AT  
 Test Mode: 01

	Ant Freq	Cable Factor	Preamp Loss	Read Level	Limit Level	Over Limit	Remark
	MHz	dB/m	dB	dBuV	dBuV/m	dBuV/m	dB
1	34.52	19.14	0.69	27.79	24.88	40.00	-23.08 QP
2	96.77	12.19	1.17	27.62	33.86	43.50	-23.90 QP
3	145.35	12.47	1.43	27.45	37.52	43.50	-19.53 QP
4	245.09	17.10	1.93	27.09	40.19	46.00	-13.87 QP
5 q	316.59	18.44	2.23	26.96	41.28	46.00	-11.01 QP
6	768.75	26.68	3.73	27.71	25.76	46.00	-17.54 QP



Unless otherwise agreed in writing, this document is issued by the Company subject to its General Conditions of Service printed overleaf, available on request or accessible at <https://www.sgs.com/en/Terms-and-Conditions>. Attention is drawn to the limitation of liability, indemnification and jurisdiction issues defined therein. Any holder of this document is advised that information contained hereon reflects the Company's findings at the time of its intervention only and within the limits of Client's instructions, if any. The Company's sole responsibility is to its Client and this document does not exonerate parties to a transaction from exercising all their rights and obligations under the transaction documents. This document cannot be reproduced except in full, without prior written approval of the Company. Any unauthorized alteration, forgery or falsification of the content or appearance of this document is unlawful and offenders may be prosecuted to the fullest extent of the law. Unless otherwise stated the results shown in this test report refer only to the sample(s) tested and such sample(s) are retained for 30 days only.

Attention: To check the authenticity of testing /inspection report & certificate, please contact us at telephone: (86-755) 8307 1443, or email: CN.Doccheck@sgs.com

No.1 Workshop, M-10, Middle Section, Science & Technology Park, Nanshan District, Shenzhen, Guangdong, China 518057 t (86-755) 26012053 f (86-755) 26710594 www.sgs.com.cn  
 中国·广东·深圳市南山区科技园中区M-10栋1号厂房 邮编: 518057 t (86-755) 26012053 f (86-755) 26710594 sgs.china@sgs.com

Test Mode: 01; Polarity: Vertical

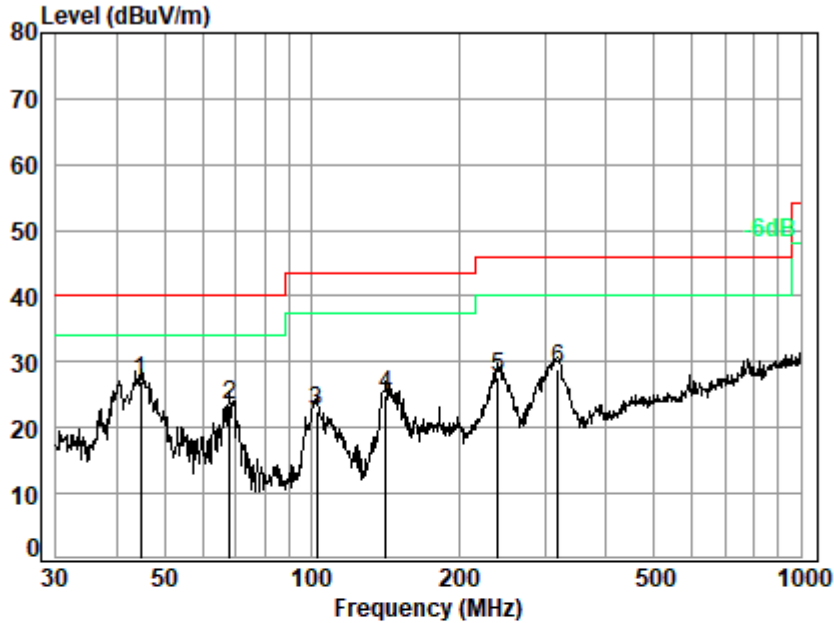

Site : chamber  
 Condition: 3m VERTICAL  
 Job No. : 00384AT  
 Test Mode: 01

	Ant Freq	Cable Factor	Preamp Loss	Read Level	Limit Level	Over Limit	Remark
	MHz	dB/m	dB	dBuV	dBuV/m	dBuV/m	dB
1 q	44.74	14.30	0.79	27.76	39.61	26.94	40.00 -13.06 QP
2	67.91	10.73	0.98	27.70	39.54	23.55	40.00 -16.45 QP
3	102.36	12.31	1.20	27.60	36.63	22.54	43.50 -20.96 QP
4	141.83	12.01	1.42	27.46	39.07	25.04	43.50 -18.46 QP
5	240.83	17.08	1.91	27.10	35.78	27.67	46.00 -18.33 QP
6	318.82	18.48	2.24	26.97	35.01	28.76	46.00 -17.24 QP



Unless otherwise agreed in writing, this document is issued by the Company subject to its General Conditions of Service printed overleaf, available on request or accessible at <https://www.sgs.com/en/Terms-and-Conditions>. Attention is drawn to the limitation of liability, indemnification and jurisdiction issues defined therein. Any holder of this document is advised that information contained hereon reflects the Company's findings at the time of its intervention only and within the limits of Client's instructions, if any. The Company's sole responsibility is to its Client and this document does not exonerate parties to a transaction from exercising all their rights and obligations under the transaction documents. This document cannot be reproduced except in full, without prior written approval of the Company. Any unauthorized alteration, forgery or falsification of the content or appearance of this document is unlawful and offenders may be prosecuted to the fullest extent of the law. Unless otherwise stated the results shown in this test report refer only to the sample(s) tested and such sample(s) are retained for 30 days only.  
 Attention: To check the authenticity of testing /inspection report & certificate, please contact us at telephone: (86-755) 8307 1443, or email: CN.Doccheck@sgs.com  
 No.1 Workshop, M-10, Middle Section, Science & Technology Park, Nanshan District, Shenzhen, Guangdong, China 518057 t (86-755) 26012053 f (86-755) 26710594 www.sgs.com.cn  
 中国·广东·深圳市南山区科技园中区M-10栋1号厂房 邮编: 518057 t (86-755) 26012053 f (86-755) 26710594 sgs.china@sgs.com

**7.9 Radiated Emissions (Above 1GHz)**

Test Requirement 47 CFR Part 15, Subpart C 15.209 & Subpart E 15.407(b)  
 Test Method: KDB 789033 D02 II G  
 Measurement Distance: 3m

Limit:

Frequency(MHz)	Field strength(microvolts/meter)	Measurement distance(meters)
Above 1GHz	500	3

\*(1) For transmitters operating in the 5.15-5.25 GHz band: All emissions outside of the 5.15-5.35 GHz band shall not exceed an e.i.r.p. of -27 dBm/MHz.

(2) For transmitters operating in the 5.25-5.35 GHz band: All emissions outside of the 5.15-5.35 GHz band shall not exceed an e.i.r.p. of -27 dBm/MHz.

(3) For transmitters operating in the 5.47-5.725 GHz band: All emissions outside of the 5.47-5.725 GHz band shall not exceed an e.i.r.p. of -27 dBm/MHz.

(4) For transmitters operating in the 5.725-5.85 GHz band:

(i) All emissions shall be limited to a level of -27 dBm/MHz at 75 MHz or more above or below the band edge increasing linearly to 10 dBm/MHz at 25 MHz above or below the band edge, and from 25 MHz above or below the band edge increasing linearly to a level of 15.6 dBm/MHz at 5 MHz above or below the band edge, and from 5 MHz above or below the band edge increasing linearly to a level of 27 dBm/MHz at the band edge.

Remark: The emission limits shown in the above table are based on measurements employing a CISPR quasi-peak detector except for the frequency bands 9-90kHz, 110-490kHz and above 1000 MHz. Radiated emission limits in these three bands are based on measurements employing an average detector, the peak field strength of any emission shall not exceed the maximum permitted average limits specified above by more than 20 Db under any condition of modulation.

**7.9.1 E.U.T. Operation**

Operating Environment:

Temperature: 18.8 °C Humidity: 31.0 % RH Atmospheric Pressure: 1000 mbar



Unless otherwise agreed in writing, this document is issued by the Company subject to its General Conditions of Service printed overleaf, available on request or accessible at <https://www.sgs.com/en/Terms-and-Conditions>. Attention is drawn to the limitation of liability, indemnification and jurisdiction issues defined therein. Any holder of this document is advised that information contained hereon reflects the Company's findings at the time of its intervention only and within the limits of Client's instructions, if any. The Company's sole responsibility is to its Client and this document does not exonerate parties to a transaction from exercising all their rights and obligations under the transaction documents. This document cannot be reproduced except in full, without prior written approval of the Company. Any unauthorized alteration, forgery or falsification of the content or appearance of this document is unlawful and offenders may be prosecuted to the fullest extent of the law. Unless otherwise stated the results shown in this test report refer only to the sample(s) tested and such sample(s) are retained for 30 days only.

Attention: To check the authenticity of testing /inspection report & certificate, please contact us at telephone: (86-755) 8307 1443, or email: CN.Doccheck@sgs.com  
 No.1 Workshop, M-10, Middle Section, Science & Technology Park, Nanshan District, Shenzhen, Guangdong, China 518057 t (86-755) 26012053 f (86-755) 26710594 www.sgs.com.cn  
 中国·广东·深圳市南山区科技园中区M-10栋1号厂房 邮编: 518057 t (86-755) 26012053 f (86-755) 26710594 sgs.china@sgs.com



**7.9.2 Test Mode Description**

Pre-scan / Final test	Mode Code	Description
Final test	01	TX mode (U-NII-5) _Keep the EUT in continuously transmitting mode with all modulation types. All data rates for each modulation type have been tested and found the data rate @ MCS0 is the worst case of IEEE 802.11a/ax 20/40/80/160, Only the data of worst case is recorded in the report.
Final test	02	TX mode (U-NII-6) _ Keep the EUT in continuously transmitting mode with all modulation types. All data rates for each modulation type have been tested and found the data rate @ MCS0 is the worst case of IEEE 802.11a/ax 20/40/80/160, Only the data of worst case is recorded in the report.
Final test	03	TX mode (U-NII-7) _ Keep the EUT in continuously transmitting mode with all modulation types. All data rates for each modulation type have been tested and found the data rate @ MCS0 is the worst case of IEEE 802.11a/ax 20/40/80/160, Only the data of worst case is recorded in the report.
Final test	04	TX mode (U-NII-8) _ Keep the EUT in continuously transmitting mode with all modulation types. All data rates for each modulation type have been tested and found the data rate @ MCS0 is the worst case of IEEE 802.11a/ax 20/40/80/160, Only the data of worst case is recorded in the report.

**7.9.3 Test Setup Diagram**

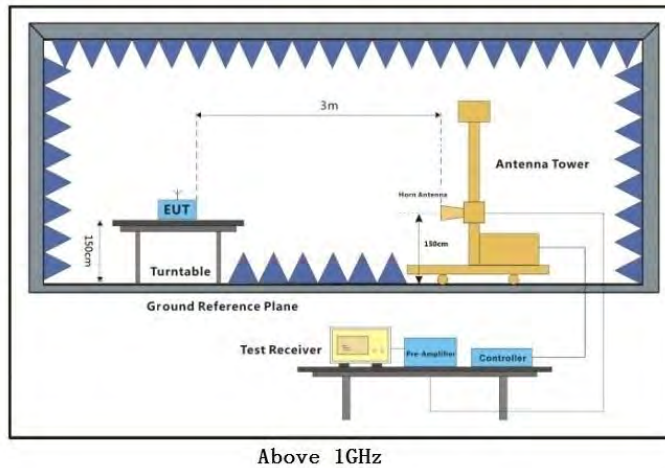

Unless otherwise agreed in writing, this document is issued by the Company subject to its General Conditions of Service printed overleaf, available on request or accessible at <https://www.sgs.com/en/Terms-and-Conditions>. Attention is drawn to the limitation of liability, indemnification and jurisdiction issues defined therein. Any holder of this document is advised that information contained hereon reflects the Company's findings at the time of its intervention only and within the limits of Client's instructions, if any. The Company's sole responsibility is to its Client and this document does not exonerate parties to a transaction from exercising all their rights and obligations under the transaction documents. This document cannot be reproduced except in full, without prior written approval of the Company. Any unauthorized alteration, forgery or falsification of the content or appearance of this document is unlawful and offenders may be prosecuted to the fullest extent of the law. Unless otherwise stated the results shown in this test report refer only to the sample(s) tested and such sample(s) are retained for 30 days only.

Attention: To check the authenticity of testing /inspection report & certificate, please contact us at telephone: (86-755) 8307 1443, or email: CN.Doccheck@sgs.com

No.1 Workshop, M-10, Middle Section, Science & Technology Park, Nanshan District, Shenzhen, Guangdong, China 518057 t (86-755) 26012053 f (86-755) 26710594 www.sgs.com.cn  
 中国·广东·深圳市南山区科技园中区M-10栋1号厂房 邮编: 518057 t (86-755) 26012053 f (86-755) 26710594 sgs.china@sgs.com

**7.9.4 Measurement Procedure and Data**

- a. For above 1GHz, the EUT was placed on the top of a rotating table 1.5 meters above the ground at a 3 meter fully-anechoic chamber. The table was rotated 360 degrees to determine the position of the highest radiation.
- b. The EUT was set 3 meters away from the interference-receiving antenna, which was mounted on the top of a variable-height antenna tower.
- c. The antenna height is varied from one meter to four meters above the ground to determine the maximum value of the field strength. Both horizontal and vertical polarizations of the antenna are set to make the measurement.
- d. For each suspected emission, the EUT was arranged to its worst case and then the antenna was tuned to heights from 1 meter to 4 meters (for the test frequency of below 30MHz, the antenna was tuned to heights 1 meter) and the rotatable table was turned from 0 degrees to 360 degrees to find the maximum reading.
- e. The test-receiver system was set to Peak Detect Function and Specified Bandwidth with Maximum Hold Mode.
- f. If the emission level of the EUT in peak mode was 10dB lower than the limit specified, then testing could be stopped and the peak values of the EUT would be reported. Otherwise the emissions that did not have 10dB margin would be re-tested one by one using peak or average method as specified and then reported in a data sheet.
- g. Test the EUT in the lowest channel, the middle channel, the Highest channel.
- h. The radiation measurements are performed in X, Y, Z axis positioning for Transmitting mode, and found the X axis positioning which it is the worst case.
- i. Repeat above procedures until all frequencies measured was complete.

Remark:

- 1. Level= Read Level+ Cable Loss+ Antenna Factor- Preamp Factor
- 2. Scan from 18GHz to 40GHz, the disturbance above 18GHz was very low. The points marked on above plots are the highest emissions could be found when testing, so only above points had been displayed. The amplitude of spurious emissions from the radiator which are attenuated more than 20dB below the limit need not be reported.
- 3. As shown in this section, for frequencies above 1GHz, the field strength limits are based on average limits. However, the peak field strength of any emission shall not exceed the maximum permitted average limits specified above by more than 20 dB under any condition of modulation. For the emissions whose peak level is lower than the average limit, only the peak measurement is shown in the report.
- 4. The disturbance above 18GHz were very low and the harmonics were the highest point could be found when testing, so only the above harmonics had been displayed.
- 5. For devices with multiple operating modes, measurements on the middle channel is used to determine the worst-case mode(s). Only the worst case mode with the highest output power and the mode with the highest output power spectral density for each modulation family (e.g., OFDM and direct sequence spread spectrum) is recorded in the test report.



Polarity: Horizontal; Modulation:802.11ax(Full RU0); Bandwidth:20MHz; Channel:Low

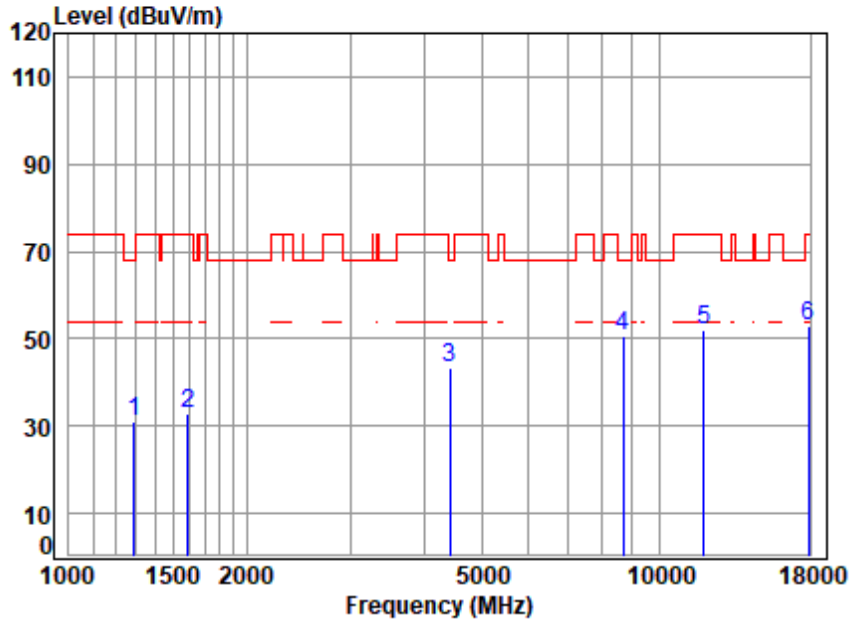

Site : chamber  
 Condition: 3m HORIZONTAL  
 Job No : 00384AT/00385AT  
 Mode : 5955 TX RSE  
 Note : 6E WIFI 11AX20

	Freq	Cable Loss	Ant Factor	Preamp Factor	Read Level	Limit Level	Over Limit	Remark
	MHz	dB	dB/m	dB	dBuV	dBuV/m	dBuV/m	dB
1	1289.627	3.74	24.86	38.36	40.93	31.17	68.20	-37.03 peak
2	1592.571	4.19	26.83	38.40	40.21	32.83	74.00	-41.17 peak
3	4417.841	7.07	34.59	35.78	37.56	43.44	68.20	-24.76 peak
4 p	8688.480	11.38	36.90	37.30	39.76	50.74	68.20	-17.46 peak
5	11910.000	13.07	37.71	37.58	38.62	51.82	74.00	-22.18 peak
6	17865.000	15.07	43.90	37.64	31.82	53.15	74.00	-20.85 peak



Unless otherwise agreed in writing, this document is issued by the Company subject to its General Conditions of Service printed overleaf, available on request or accessible at <https://www.sgs.com/en/Terms-and-Conditions>. Attention is drawn to the limitation of liability, indemnification and jurisdiction issues defined therein. Any holder of this document is advised that information contained hereon reflects the Company's findings at the time of its intervention only and within the limits of Client's instructions, if any. The Company's sole responsibility is to its Client and this document does not exonerate parties to a transaction from exercising all their rights and obligations under the transaction documents. This document cannot be reproduced except in full, without prior written approval of the Company. Any unauthorized alteration, forgery or falsification of the content or appearance of this document is unlawful and offenders may be prosecuted to the fullest extent of the law. Unless otherwise stated the results shown in this test report refer only to the sample(s) tested and such sample(s) are retained for 30 days only.

Attention: To check the authenticity of testing /inspection report & certificate, please contact us at telephone: (86-755) 8307 1443, or email: CN.Doccheck@sgs.com  
 No.1 Workshop, M-10, Middle Section, Science & Technology Park, Nanshan District, Shenzhen, Guangdong, China 518057 t (86-755) 26012053 f (86-755) 26710594 www.sgs.com.cn  
 中国·广东·深圳市南山区科技园中区M-10栋1号厂房 邮编: 518057 t (86-755) 26012053 f (86-755) 26710594 sgs.china@sgs.com



Polarity: Vertical; Modulation:802.11ax(Full RU0); Bandwidth:20MHz; Channel:Low

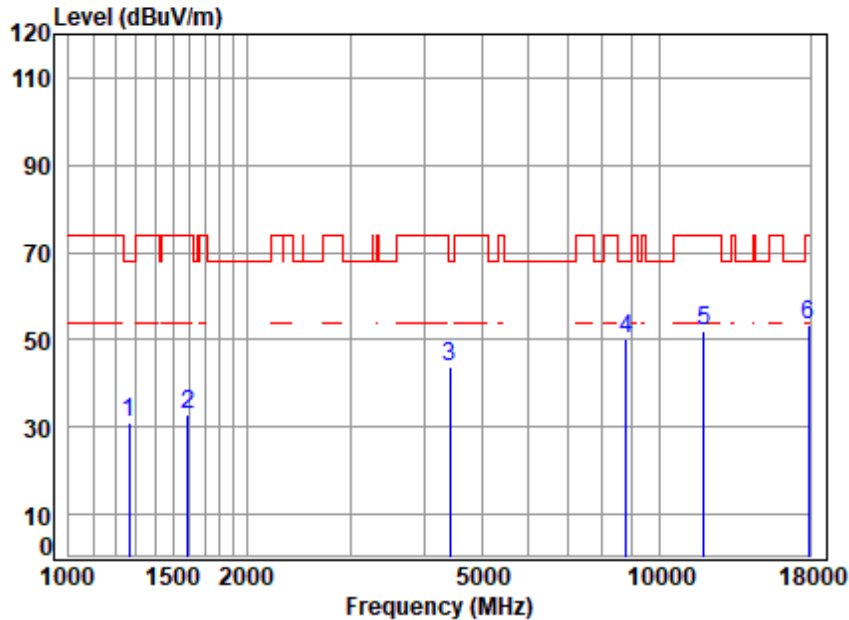

Site : chamber  
 Condition: 3m VERTICAL  
 Job No : 00384AT/00385AT  
 Mode : 5955 TX RSE  
 Note : 6E WIFI 11AX20

	Freq	Cable Loss	Ant Factor	Preamp Factor	Read Level	Limit Level	Over Limit	Remark
	MHz	dB	dB/m	dB	dBuV	dBuV/m	dBuV/m	dB
1	1263.796	3.69	25.02	38.35	40.66	31.02	68.20	-37.18 peak
2	1592.571	4.19	26.83	38.40	40.17	32.79	74.00	-41.21 peak
3	4417.841	7.07	34.59	35.78	37.72	43.60	68.20	-24.60 peak
4 p	8789.516	11.55	37.06	37.40	39.21	50.42	68.20	-17.78 peak
5	11910.000	13.07	37.71	37.58	38.74	51.94	74.00	-22.06 peak
6	17865.000	15.07	43.90	37.64	31.83	53.16	74.00	-20.84 peak



Unless otherwise agreed in writing, this document is issued by the Company subject to its General Conditions of Service printed overleaf, available on request or accessible at <https://www.sgs.com/en/Terms-and-Conditions>. Attention is drawn to the limitation of liability, indemnification and jurisdiction issues defined therein. Any holder of this document is advised that information contained hereon reflects the Company's findings at the time of its intervention only and within the limits of Client's instructions, if any. The Company's sole responsibility is to its Client and this document does not exonerate parties to a transaction from exercising all their rights and obligations under the transaction documents. This document cannot be reproduced except in full, without prior written approval of the Company. Any unauthorized alteration, forgery or falsification of the content or appearance of this document is unlawful and offenders may be prosecuted to the fullest extent of the law. Unless otherwise stated the results shown in this test report refer only to the sample(s) tested and such sample(s) are retained for 30 days only.

Attention: To check the authenticity of testing /inspection report & certificate, please contact us at telephone: (86-755) 8307 1443, or email: CN.Doccheck@sgs.com  
 No.1 Workshop, M-10, Middle Section, Science & Technology Park, Nanshan District, Shenzhen, Guangdong, China 518057 t (86-755) 26012053 f (86-755) 26710594 www.sgsgroup.com.cn  
 中国·广东·深圳市南山区科技园中区M-10栋1号厂房 邮编: 518057 t (86-755) 26012053 f (86-755) 26710594 sgs.china@sgs.com

Polarity: Horizontal; Modulation:802.11ax(Full RU0); Bandwidth:20MHz; Channel:middle

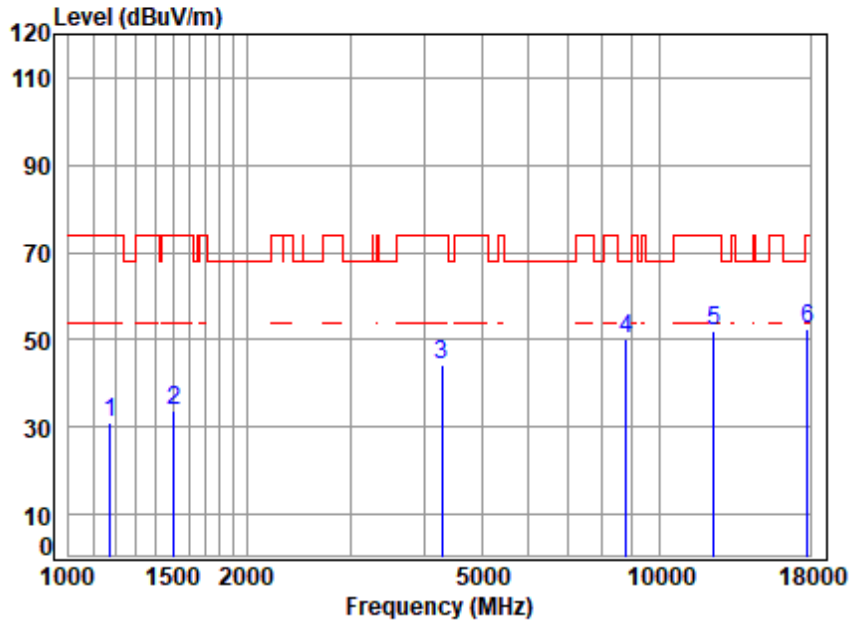

Site : chamber  
 Condition: 3m HORIZONTAL  
 Job No : 00384AT/00385AT  
 Mode : 6175 TX RSE  
 Note : 6E WIFI 11AX20

	Freq	Cable Loss	Ant Factor	Preamp Factor	Read Level	Limit Level	Over Limit	Remark
	MHz	dB	dB/m	dB	dBuV	dBuV/m	dBuV/m	dB
1	1175.697	3.54	24.16	38.34	41.89	74.00	-42.75	peak
2	1507.470	4.07	26.83	38.39	41.26	74.00	-40.23	peak
3	4279.589	6.98	33.92	35.89	39.22	74.00	-29.77	peak
4 p	8789.516	11.55	37.06	37.40	39.16	68.20	-17.83	peak
5	12350.000	13.26	37.90	37.45	38.53	74.00	-21.76	peak
6	17793.090	15.03	43.89	37.63	31.24	74.00	-21.47	peak



Unless otherwise agreed in writing, this document is issued by the Company subject to its General Conditions of Service printed overleaf, available on request or accessible at <https://www.sgs.com/en/Terms-and-Conditions>. Attention is drawn to the limitation of liability, indemnification and jurisdiction issues defined therein. Any holder of this document is advised that information contained hereon reflects the Company's findings at the time of its intervention only and within the limits of Client's instructions, if any. The Company's sole responsibility is to its Client and this document does not exonerate parties to a transaction from exercising all their rights and obligations under the transaction documents. This document cannot be reproduced except in full, without prior written approval of the Company. Any unauthorized alteration, forgery or falsification of the content or appearance of this document is unlawful and offenders may be prosecuted to the fullest extent of the law. Unless otherwise stated the results shown in this test report refer only to the sample(s) tested and such sample(s) are retained for 30 days only.

Attention: To check the authenticity of testing /inspection report & certificate, please contact us at telephone: (86-755) 8307 1443, or email: CN.Doccheck@sgs.com

No.1 Workshop, M-10, Middle Section, Science & Technology Park, Nanshan District, Shenzhen, Guangdong, China 518057 t (86-755) 26012053 f (86-755) 26710594 www.sgsgroup.com.cn  
 中国·广东·深圳市南山区科技园中区M-10栋1号厂房 邮编: 518057 t (86-755) 26012053 f (86-755) 26710594 sgs.china@sgs.com

Polarity: Vertical; Modulation:802.11ax(Full RU0); Bandwidth:20MHz; Channel:middle

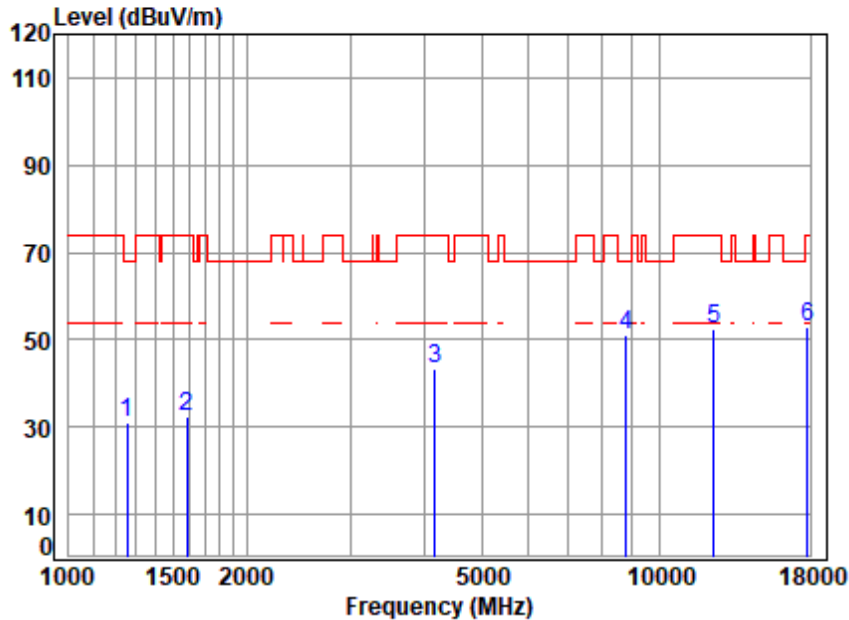

Site : chamber  
 Condition: 3m VERTICAL  
 Job No : 00384AT/00385AT  
 Mode : 6175 TX RSE  
 Note : 6E WIFI 11AX20

	Freq	Cable Loss	Ant Factor	Preamp Factor	Read Level	Limit Level	Over Line	Over Limit	Remark
	MHz	dB	dB/m	dB	dBuV	dBuV/m	dBuV/m	dB	
1	1256.512	3.68	25.06	38.35	40.52	30.91	68.20	-37.29	peak
2	1583.392	4.18	26.87	38.40	39.85	32.50	74.00	-41.50	peak
3	4169.698	6.90	33.80	35.97	38.43	43.16	74.00	-30.84	peak
4 p	8789.516	11.55	37.06	37.40	39.89	51.10	68.20	-17.10	peak
5	12350.000	13.26	37.90	37.45	38.78	52.49	74.00	-21.51	peak
6	17793.090	15.03	43.89	37.63	31.62	52.91	74.00	-21.09	peak



Unless otherwise agreed in writing, this document is issued by the Company subject to its General Conditions of Service printed overleaf, available on request or accessible at <https://www.sgs.com/en/Terms-and-Conditions>. Attention is drawn to the limitation of liability, indemnification and jurisdiction issues defined therein. Any holder of this document is advised that information contained hereon reflects the Company's findings at the time of its intervention only and within the limits of Client's instructions, if any. The Company's sole responsibility is to its Client and this document does not exonerate parties to a transaction from exercising all their rights and obligations under the transaction documents. This document cannot be reproduced except in full, without prior written approval of the Company. Any unauthorized alteration, forgery or falsification of the content or appearance of this document is unlawful and offenders may be prosecuted to the fullest extent of the law. Unless otherwise stated the results shown in this test report refer only to the sample(s) tested and such sample(s) are retained for 30 days only.

Attention: To check the authenticity of testing /inspection report & certificate, please contact us at telephone: (86-755) 8307 1443, or email: CN.Doccheck@sgs.com  
 No.1 Workshop, M-10, Middle Section, Science & Technology Park, Nanshan District, Shenzhen, Guangdong, China 518057 t (86-755) 26012053 f (86-755) 26710594 www.sgsgroup.com.cn  
 中国·广东·深圳市南山区科技园中区M-10栋1号厂房 邮编: 518057 t (86-755) 26012053 f (86-755) 26710594 sgs.china@sgs.com



Polarity: Horizontal; Modulation:802.11ax(Full RU0); Bandwidth:20MHz; Channel:High

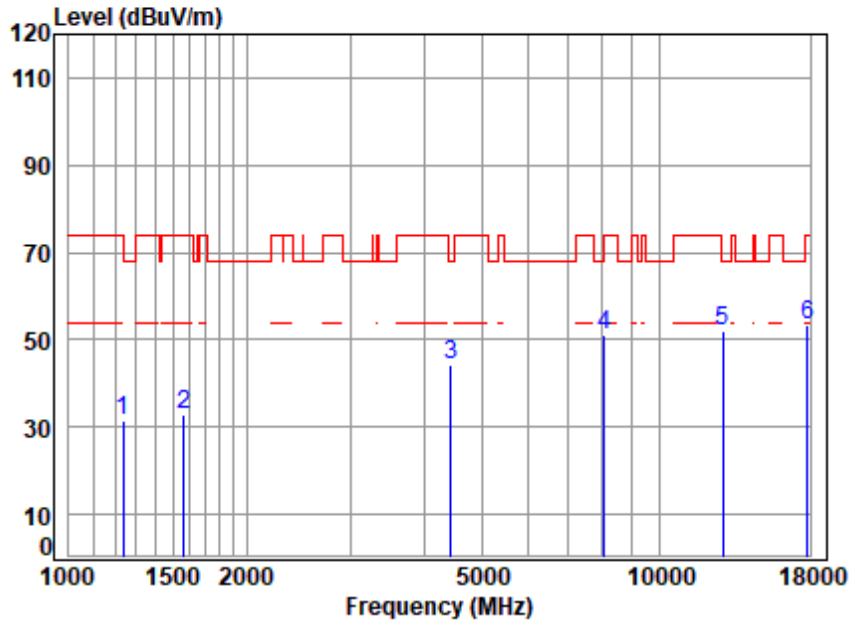

Site : chamber  
 Condition: 3m HORIZONTAL  
 Job No : 00384AT/00385AT  
 Mode : 6395 TX RSE  
 Note : 6E WIFI 11AX20

	Freq	Cable Loss	Ant Factor	Preamp Factor	Read Level	Limit Level	Over Limit	Remark
	MHz	dB	dB/m	dB	dBuV	dBuV/m	dBuV/m	dB
1	1238.483	3.65	24.94	38.35	41.12	74.00	-42.64	peak
2	1565.191	4.15	26.94	38.40	40.04	74.00	-41.27	peak
3	4443.453	7.09	34.28	35.77	38.49	68.20	-24.11	peak
4	8059.475	10.21	36.42	36.63	41.03	74.00	-22.97	peak
5	12790.000	13.46	38.10	37.33	37.71	68.20	-16.26	peak
6	17844.590	15.06	43.90	37.64	31.97	74.00	-20.71	peak



Unless otherwise agreed in writing, this document is issued by the Company subject to its General Conditions of Service printed overleaf, available on request or accessible at <https://www.sgs.com/en/Terms-and-Conditions>. Attention is drawn to the limitation of liability, indemnification and jurisdiction issues defined therein. Any holder of this document is advised that information contained hereon reflects the Company's findings at the time of its intervention only and within the limits of Client's instructions, if any. The Company's sole responsibility is to its Client and this document does not exonerate parties to a transaction from exercising all their rights and obligations under the transaction documents. This document cannot be reproduced except in full, without prior written approval of the Company. Any unauthorized alteration, forgery or falsification of the content or appearance of this document is unlawful and offenders may be prosecuted to the fullest extent of the law. Unless otherwise stated the results shown in this test report refer only to the sample(s) tested and such sample(s) are retained for 30 days only.

Attention: To check the authenticity of testing /inspection report & certificate, please contact us at telephone: (86-755) 8307 1443, or email: CN.Doccheck@sgs.com  
 No.1 Workshop, M-10, Middle Section, Science & Technology Park, Nanshan District, Shenzhen, Guangdong, China 518057 t (86-755) 26012053 f (86-755) 26710594 www.sgs.com.cn  
 中国·广东·深圳市南山区科技园中区M-10栋1号厂房 邮编: 518057 t (86-755) 26012053 f (86-755) 26710594 sgs.china@sgs.com

Polarity: Vertical; Modulation:802.11ax(Full RU0); Bandwidth:20MHz; Channel:High

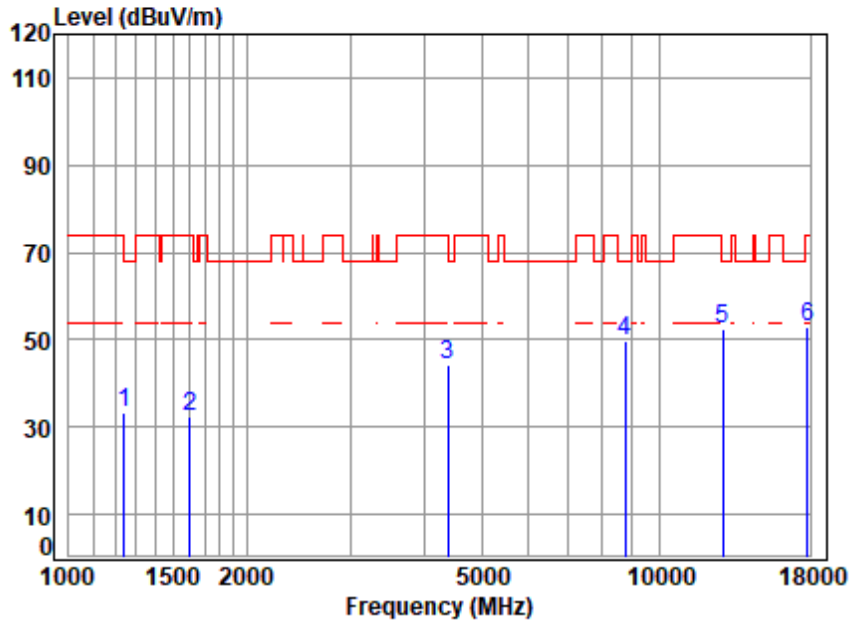

Site : chamber  
 Condition: 3m VERTICAL  
 Job No : 00384AT/00385AT  
 Mode : 6395 TX RSE  
 Note : 6E WIFI 11AX20

	Freq	Cable Loss	Ant Factor	Preamp Factor	Read Level	Limit Level	Over Limit	Remark
	MHz	dB	dB/m	dB	dBuV	dBuV/m	dBuV/m	dB
1	1242.068	3.66	24.99	38.35	43.00	33.30	68.20	-34.90 peak
2	1606.441	4.21	26.74	38.40	39.91	32.46	74.00	-41.54 peak
3	4392.376	7.05	34.74	35.80	38.48	44.47	74.00	-29.53 peak
4	8764.146	11.51	36.96	37.37	38.66	49.76	68.20	-18.44 peak
5	12790.000	13.46	38.10	37.33	38.04	52.27	68.20	-15.93 peak
6	17844.590	15.06	43.90	37.64	31.40	52.72	74.00	-21.28 peak



Unless otherwise agreed in writing, this document is issued by the Company subject to its General Conditions of Service printed overleaf, available on request or accessible at <https://www.sgs.com/en/Terms-and-Conditions>. Attention is drawn to the limitation of liability, indemnification and jurisdiction issues defined therein. Any holder of this document is advised that information contained hereon reflects the Company's findings at the time of its intervention only and within the limits of Client's instructions, if any. The Company's sole responsibility is to its Client and this document does not exonerate parties to a transaction from exercising all their rights and obligations under the transaction documents. This document cannot be reproduced except in full, without prior written approval of the Company. Any unauthorized alteration, forgery or falsification of the content or appearance of this document is unlawful and offenders may be prosecuted to the fullest extent of the law. Unless otherwise stated the results shown in this test report refer only to the sample(s) tested and such sample(s) are retained for 30 days only.

Attention: To check the authenticity of testing /inspection report & certificate, please contact us at telephone: (86-755) 8307 1443, or email: CN.Doccheck@sgs.com  
 No.1 Workshop, M-10, Middle Section, Science & Technology Park, Nanshan District, Shenzhen, Guangdong, China 518057 t (86-755) 26012053 f (86-755) 26710594 www.sgs.com.cn  
 中国·广东·深圳市南山区科技园中区M-10栋1号厂房 邮编: 518057 t (86-755) 26012053 f (86-755) 26710594 sgs.china@sgs.com

Polarity: Horizontal; Modulation:802.11ax(Full RU0); Bandwidth:40MHz; Channel:Low

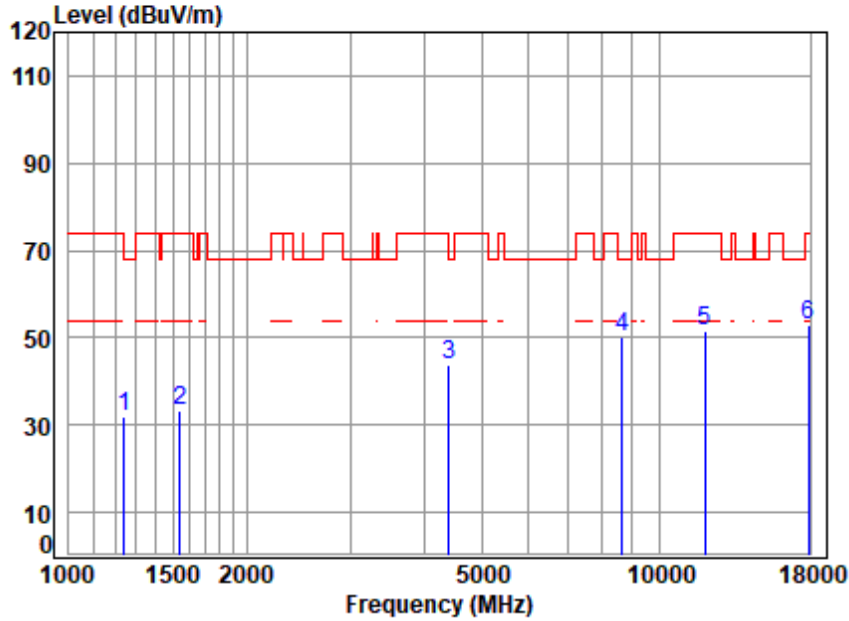

Site : chamber  
 Condition: 3m HORIZONTAL  
 Job No : 00384AT/00385AT  
 Mode : 5965 TX RSE  
 Note : 6E WIFI 11AX40

	Freq	Cable Loss	Ant Factor	Preamp Factor	Read Level	Limit Level	Over Limit	Remark
	MHz	dB	dB/m	dB	dBuV	dBuV/m	dBuV/m	dB
1	1242.068	3.66	24.99	38.35	41.87	32.17	68.20	-36.03 peak
2	1542.733	4.12	26.97	38.39	40.45	33.15	74.00	-40.85 peak
3	4405.090	7.06	34.74	35.79	37.95	43.96	68.20	-24.24 peak
4 p	8663.404	11.33	36.90	37.27	39.06	50.02	68.20	-18.18 peak
5	11930.000	13.08	37.73	37.57	38.29	51.53	74.00	-22.47 peak
6	17895.000	15.09	43.90	37.64	31.36	52.71	74.00	-21.29 peak



Unless otherwise agreed in writing, this document is issued by the Company subject to its General Conditions of Service printed overleaf, available on request or accessible at <https://www.sgs.com/en/Terms-and-Conditions>. Attention is drawn to the limitation of liability, indemnification and jurisdiction issues defined therein. Any holder of this document is advised that information contained hereon reflects the Company's findings at the time of its intervention only and within the limits of Client's instructions, if any. The Company's sole responsibility is to its Client and this document does not exonerate parties to a transaction from exercising all their rights and obligations under the transaction documents. This document cannot be reproduced except in full, without prior written approval of the Company. Any unauthorized alteration, forgery or falsification of the content or appearance of this document is unlawful and offenders may be prosecuted to the fullest extent of the law. Unless otherwise stated the results shown in this test report refer only to the sample(s) tested and such sample(s) are retained for 30 days only.  
 Attention: To check the authenticity of testing /inspection report & certificate, please contact us at telephone: (86-755) 8307 1443, or email: CN.Doccheck@sgs.com  
 No.1 Workshop, M-10, Middle Section, Science & Technology Park, Nanshan District, Shenzhen, Guangdong, China 518057 t (86-755) 26012053 f (86-755) 26710594 www.sgsgroup.com.cn  
 中国·广东·深圳市南山区科技园中区M-10栋1号厂房 邮编: 518057 t (86-755) 26012053 f (86-755) 26710594 sgs.china@sgs.com



Polarity: Vertical; Modulation:802.11ax(Full RU0); Bandwidth:40MHz; Channel:Low

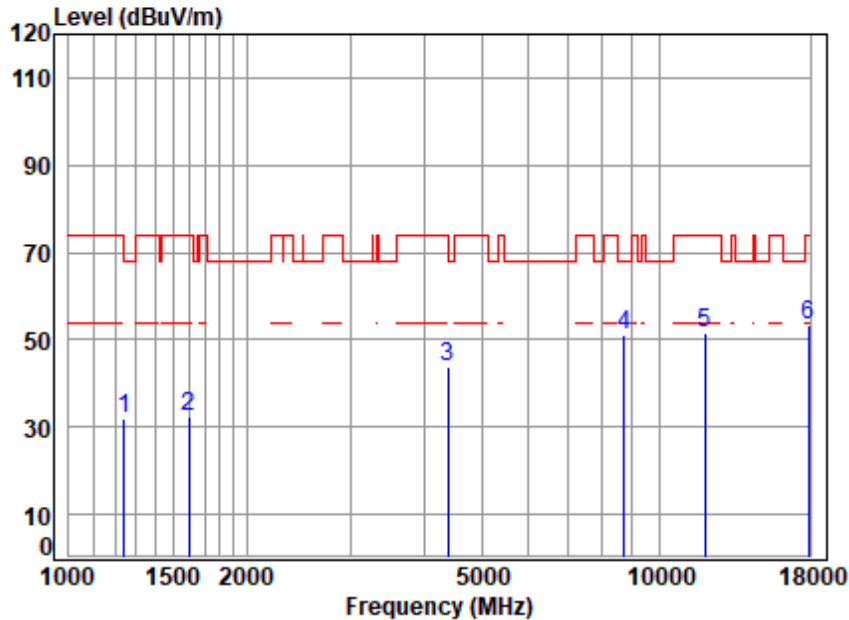

Site : chamber  
 Condition: 3m VERTICAL  
 Job No : 00384AT/00385AT  
 Mode : 5965 TX RSE  
 Note : 6E WIFI 11AX40

	Freq	Cable Loss	Ant Factor	Preamp Factor	Read Level	Limit Level	Over Line	Over Limit	Remark
	MHz	dB	dB/m	dB	dBuV	dBuV/m	dBuV/m	dB	
1	1242.068	3.66	24.99	38.35	41.56	31.86	68.20	-36.34	peak
2	1597.181	4.20	26.81	38.40	39.68	32.29	74.00	-41.71	peak
3	4379.699	7.04	34.64	35.81	37.81	43.68	74.00	-30.32	peak
4 p	8713.630	11.42	36.90	37.32	39.91	50.91	68.20	-17.29	peak
5	11930.000	13.08	37.73	37.57	38.44	51.68	74.00	-22.32	peak
6	17895.000	15.09	43.90	37.64	31.90	53.25	74.00	-20.75	peak



Unless otherwise agreed in writing, this document is issued by the Company subject to its General Conditions of Service printed overleaf, available on request or accessible at <https://www.sgs.com/en/Terms-and-Conditions>. Attention is drawn to the limitation of liability, indemnification and jurisdiction issues defined therein. Any holder of this document is advised that information contained hereon reflects the Company's findings at the time of its intervention only and within the limits of Client's instructions, if any. The Company's sole responsibility is to its Client and this document does not exonerate parties to a transaction from exercising all their rights and obligations under the transaction documents. This document cannot be reproduced except in full, without prior written approval of the Company. Any unauthorized alteration, forgery or falsification of the content or appearance of this document is unlawful and offenders may be prosecuted to the fullest extent of the law. Unless otherwise stated the results shown in this test report refer only to the sample(s) tested and such sample(s) are retained for 30 days only.

Attention: To check the authenticity of testing /inspection report & certificate, please contact us at telephone: (86-755) 8307 1443, or email: CN.Doccheck@sgs.com  
 No.1 Workshop, M-10, Middle Section, Science & Technology Park, Nanshan District, Shenzhen, Guangdong, China 518057 t (86-755) 26012053 f (86-755) 26710594 www.sgs.com.cn  
 中国·广东·深圳市南山区科技园中区M-10栋1号厂房 邮编: 518057 t (86-755) 26012053 f (86-755) 26710594 sgs.china@sgs.com

Polarity: Horizontal; Modulation:802.11ax(Full RU0); Bandwidth:40MHz; Channel:middle

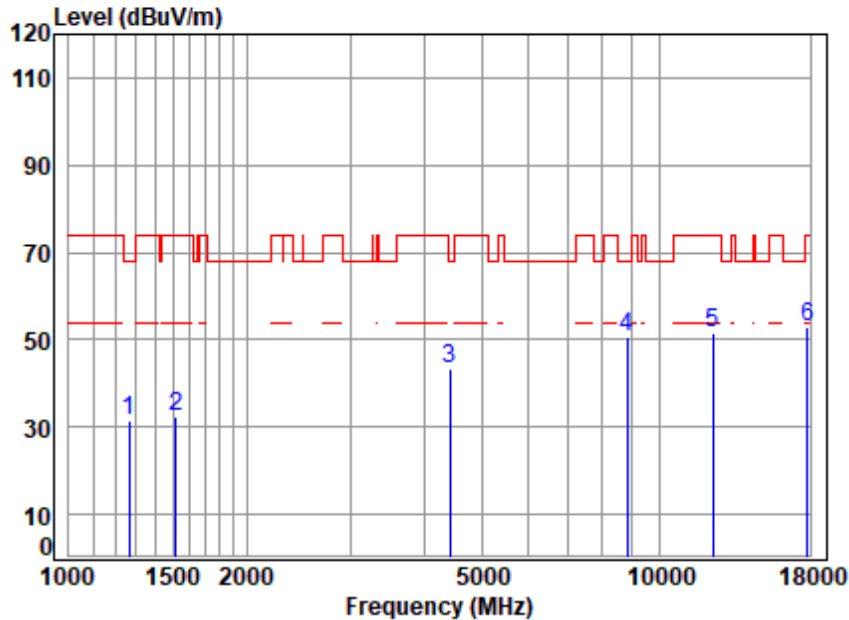

Site : chamber  
 Condition: 3m HORIZONTAL  
 Job No : 00384AT/00385AT  
 Mode : 6165 TX RSE  
 Note : 6E WIFI 11AX40

	Freq	Cable Loss	Ant Factor	Preamp Factor	Read Level	Limit Level	Over Limit	Remark
	MHz	dB	dB/m	dB	dBuV	dBuV/m	dBuV/m	dB
1	1267.454	3.70	25.00	38.35	40.92	68.20	-36.93	peak
2	1516.210	4.08	26.86	38.39	39.93	74.00	-41.52	peak
3	4417.841	7.07	34.59	35.78	37.31	68.20	-25.01	peak
4 p	8814.957	11.60	37.13	37.42	39.39	68.20	-17.50	peak
5	12330.000	13.25	37.90	37.46	38.09	74.00	-22.22	peak
6	17844.590	15.06	43.90	37.64	31.38	74.00	-21.30	peak



Unless otherwise agreed in writing, this document is issued by the Company subject to its General Conditions of Service printed overleaf, available on request or accessible at <https://www.sgs.com/en/Terms-and-Conditions>. Attention is drawn to the limitation of liability, indemnification and jurisdiction issues defined therein. Any holder of this document is advised that information contained hereon reflects the Company's findings at the time of its intervention only and within the limits of Client's instructions, if any. The Company's sole responsibility is to its Client and this document does not exonerate parties to a transaction from exercising all their rights and obligations under the transaction documents. This document cannot be reproduced except in full, without prior written approval of the Company. Any unauthorized alteration, forgery or falsification of the content or appearance of this document is unlawful and offenders may be prosecuted to the fullest extent of the law. Unless otherwise stated the results shown in this test report refer only to the sample(s) tested and such sample(s) are retained for 30 days only.

Attention: To check the authenticity of testing /inspection report & certificate, please contact us at telephone: (86-755) 8307 1443, or email: CN.Doccheck@sgs.com  
 No.1 Workshop, M-10, Middle Section, Science & Technology Park, Nanshan District, Shenzhen, Guangdong, China 518057 t (86-755) 26012053 f (86-755) 26710594 www.sgs.com.cn  
 中国·广东·深圳市南山区科技园中区M-10栋1号厂房 邮编: 518057 t (86-755) 26012053 f (86-755) 26710594 sgs.china@sgs.com

Polarity: Vertical; Modulation:802.11ax(Full RU0); Bandwidth:40MHz; Channel:middle

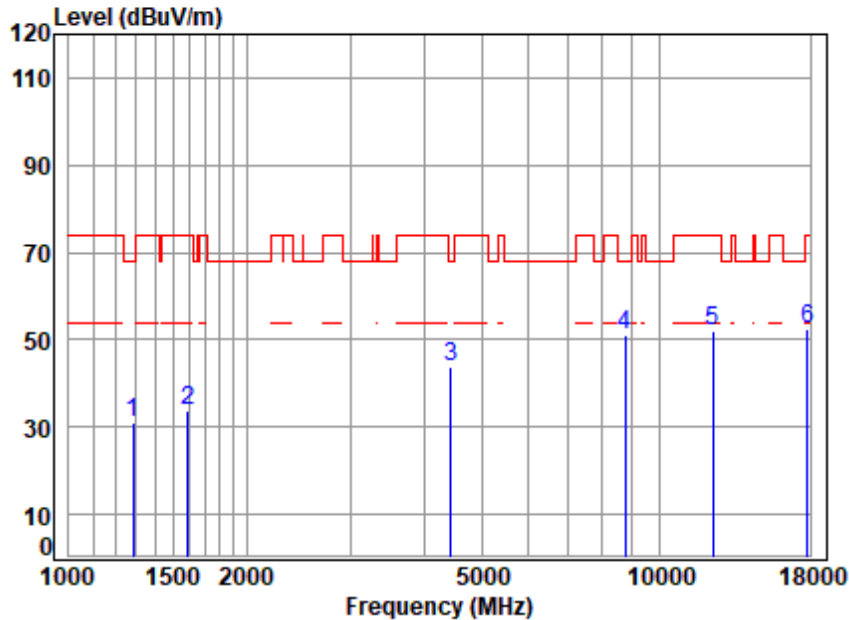

Site : chamber  
 Condition: 3m VERTICAL  
 Job No : 00384AT/00385AT  
 Mode : 6165 TX RSE  
 Note : 6E WIFI 11AX40

	Freq	Cable Loss	Ant Factor	Preamp Factor	Read Level	Limit Level	Over Line	Over Limit	Remark
	MHz	dB	dB/m	dB	dBuV	dBuV/m	dBuV/m	dB	
1	1285.904	3.73	24.88	38.35	40.72	30.98	68.20	-37.22	peak
2	1592.571	4.19	26.83	38.40	41.14	33.76	74.00	-40.24	peak
3	4443.453	7.09	34.28	35.77	38.19	43.79	68.20	-24.41	peak
4 p	8738.852	11.47	36.90	37.35	40.08	51.10	68.20	-17.10	peak
5	12330.000	13.25	37.90	37.46	38.29	51.98	74.00	-22.02	peak
6	17844.590	15.06	43.90	37.64	31.15	52.47	74.00	-21.53	peak



Unless otherwise agreed in writing, this document is issued by the Company subject to its General Conditions of Service printed overleaf, available on request or accessible at <https://www.sgs.com/en/Terms-and-Conditions>. Attention is drawn to the limitation of liability, indemnification and jurisdiction issues defined therein. Any holder of this document is advised that information contained hereon reflects the Company's findings at the time of its intervention only and within the limits of Client's instructions, if any. The Company's sole responsibility is to its Client and this document does not exonerate parties to a transaction from exercising all their rights and obligations under the transaction documents. This document cannot be reproduced except in full, without prior written approval of the Company. Any unauthorized alteration, forgery or falsification of the content or appearance of this document is unlawful and offenders may be prosecuted to the fullest extent of the law. Unless otherwise stated the results shown in this test report refer only to the sample(s) tested and such sample(s) are retained for 30 days only.

Attention: To check the authenticity of testing /inspection report & certificate, please contact us at telephone: (86-755) 8307 1443, or email: CN.Doccheck@sgs.com  
 No.1 Workshop, M-10, Middle Section, Science & Technology Park, Nanshan District, Shenzhen, Guangdong, China 518057 t (86-755) 26012053 f (86-755) 26710594 www.sgs.com.cn  
 中国·广东·深圳市南山区科技园中区M-10栋1号厂房 邮编: 518057 t (86-755) 26012053 f (86-755) 26710594 sgs.china@sgs.com



Polarity: Horizontal; Modulation:802.11ax(Full RU0); Bandwidth:40MHz; Channel:High

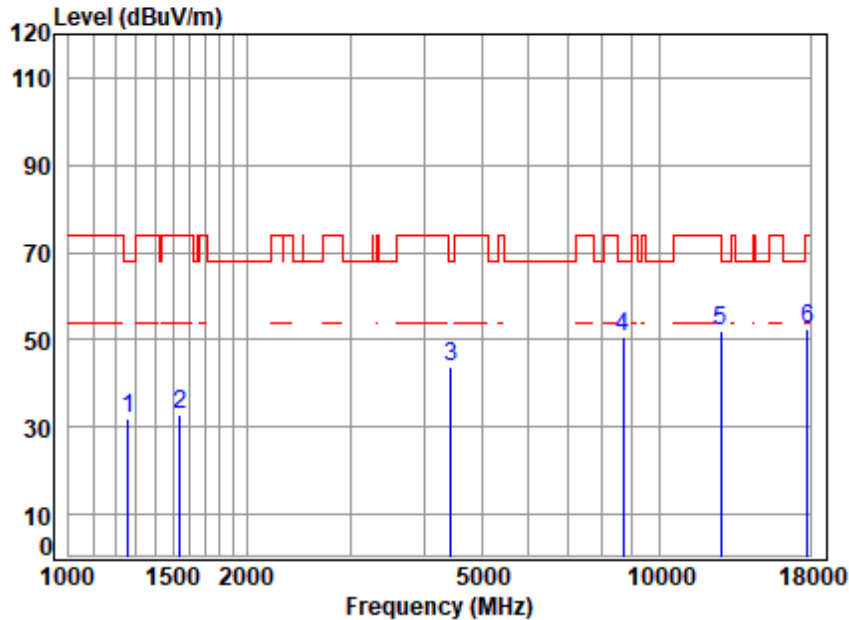

Site : chamber  
 Condition: 3m HORIZONTAL  
 Job No : 00384AT/00385AT  
 Mode : 6365 TX RSE  
 Note : 6E WIFI 11AX40

	Freq	Cable Loss	Ant Factor	Preamp Factor	Read Level	Limit Level	Over Limit	Remark
	MHz	dB	dB/m	dB	dBuV	dBuV/m	dBuV/m	dB
1	1260.149	3.69	25.04	38.35	41.72	32.10	68.20	-36.10 peak
2	1542.733	4.12	26.97	38.39	39.93	32.63	74.00	-41.37 peak
3	4430.628	7.08	34.43	35.77	37.86	43.60	68.20	-24.60 peak
4	8688.480	11.38	36.90	37.30	39.65	50.63	68.20	-17.57 peak
5	12730.000	13.43	38.10	37.34	37.90	52.09	68.20	-16.11 peak
6	17844.590	15.06	43.90	37.64	31.34	52.66	74.00	-21.34 peak



Unless otherwise agreed in writing, this document is issued by the Company subject to its General Conditions of Service printed overleaf, available on request or accessible at <https://www.sgs.com/en/Terms-and-Conditions>. Attention is drawn to the limitation of liability, indemnification and jurisdiction issues defined therein. Any holder of this document is advised that information contained hereon reflects the Company's findings at the time of its intervention only and within the limits of Client's instructions, if any. The Company's sole responsibility is to its Client and this document does not exonerate parties to a transaction from exercising all their rights and obligations under the transaction documents. This document cannot be reproduced except in full, without prior written approval of the Company. Any unauthorized alteration, forgery or falsification of the content or appearance of this document is unlawful and offenders may be prosecuted to the fullest extent of the law. Unless otherwise stated the results shown in this test report refer only to the sample(s) tested and such sample(s) are retained for 30 days only.

Attention: To check the authenticity of testing /inspection report & certificate, please contact us at telephone: (86-755) 8307 1443, or email: CN.Doccheck@sgs.com  
 No.1 Workshop, M-10, Middle Section, Science & Technology Park, Nanshan District, Shenzhen, Guangdong, China 518057 t (86-755) 26012053 f (86-755) 26710594 www.sgs.com.cn  
 中国·广东·深圳市南山区科技园中区M-10栋1号厂房 邮编: 518057 t (86-755) 26012053 f (86-755) 26710594 sgs.china@sgs.com

Polarity: Vertical; Modulation:802.11ax(Full RU0); Bandwidth:40MHz; Channel:High

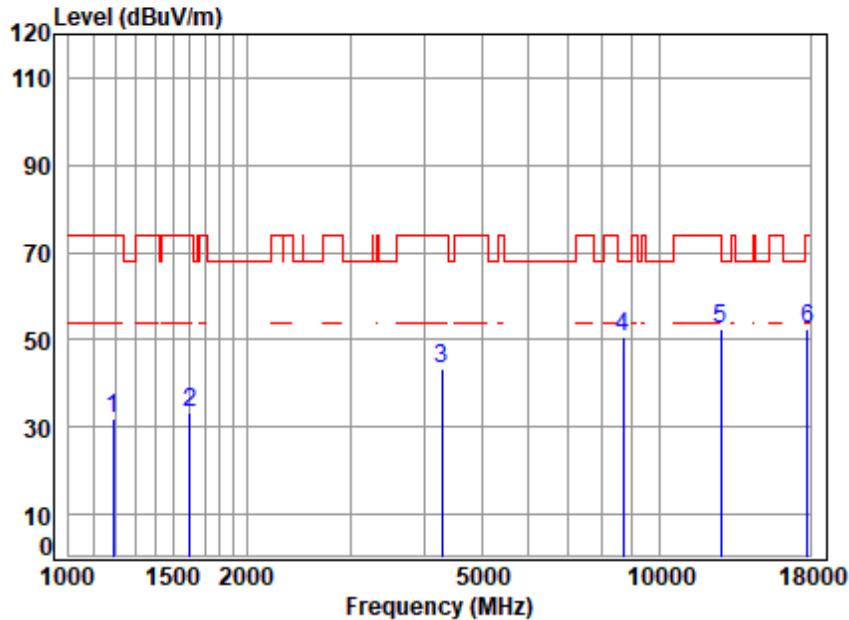

Site : chamber  
 Condition: 3m VERTICAL  
 Job No : 00384AT/00385AT  
 Mode : 6365 TX RSE  
 Note : 6E WIFI 11AX40

	Freq	Cable Loss	Ant Factor	Preamp Factor	Read Level	Limit Level	Over Limit	Remark
	MHz	dB	dB/m	dB	dBuV	dBuV/m	dBuV/m	dB
1	1189.368	3.56	24.29	38.34	42.39	74.00	-42.10	peak
2	1606.441	4.21	26.74	38.40	40.85	74.00	-40.60	peak
3	4279.589	6.98	33.92	35.89	38.22	74.00	-30.77	peak
4	8688.480	11.38	36.90	37.30	39.64	68.20	-17.58	peak
5	12730.000	13.43	38.10	37.34	38.40	68.20	-15.61	peak
6	17793.090	15.03	43.89	37.63	31.32	74.00	-21.39	peak



Unless otherwise agreed in writing, this document is issued by the Company subject to its General Conditions of Service printed overleaf, available on request or accessible at <https://www.sgs.com/en/Terms-and-Conditions>. Attention is drawn to the limitation of liability, indemnification and jurisdiction issues defined therein. Any holder of this document is advised that information contained hereon reflects the Company's findings at the time of its intervention only and within the limits of Client's instructions, if any. The Company's sole responsibility is to its Client and this document does not exonerate parties to a transaction from exercising all their rights and obligations under the transaction documents. This document cannot be reproduced except in full, without prior written approval of the Company. Any unauthorized alteration, forgery or falsification of the content or appearance of this document is unlawful and offenders may be prosecuted to the fullest extent of the law. Unless otherwise stated the results shown in this test report refer only to the sample(s) tested and such sample(s) are retained for 30 days only.

Attention: To check the authenticity of testing /inspection report & certificate, please contact us at telephone: (86-755) 8307 1443, or email: CN.Doccheck@sgs.com  
 No.1 Workshop, M-10, Middle Section, Science & Technology Park, Nanshan District, Shenzhen, Guangdong, China 518057 t (86-755) 26012053 f (86-755) 26710594 www.sgs.com.cn  
 中国·广东·深圳市南山区科技园中区M-10栋1号厂房 邮编: 518057 t (86-755) 26012053 f (86-755) 26710594 sgs.china@sgs.com

Polarity: Horizontal; Modulation:802.11ax(Full RU0); Bandwidth:80MHz; Channel:Low

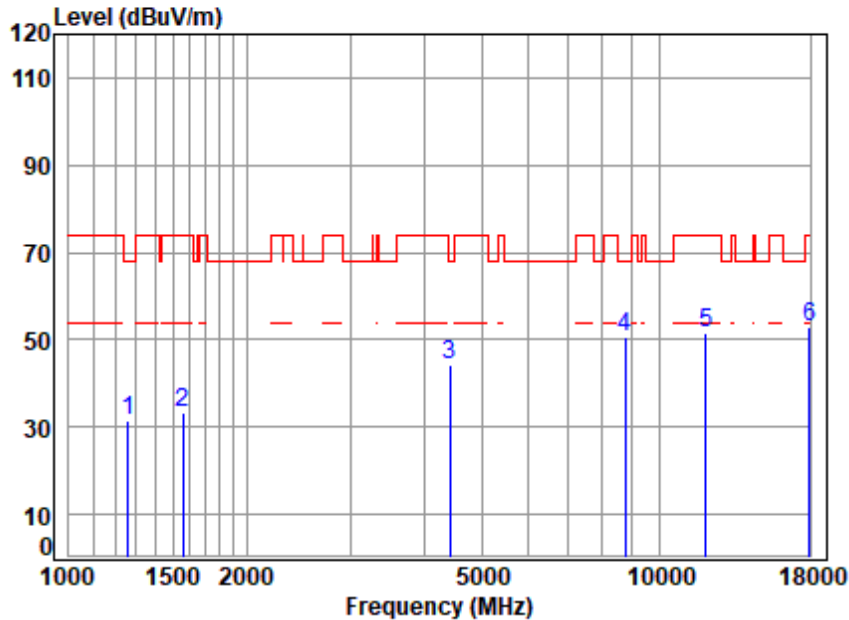

Site : chamber  
 Condition: 3m HORIZONTAL  
 Job No : 00384AT/00385AT  
 Mode : 5985 TX RSE  
 Note : 6E WIFI 11AX80

	Freq	Cable Loss	Ant Factor	Preamp Factor	Read Level	Limit Level	Over Limit	Remark
	MHz	dB	dB/m	dB	dBuV	dBuV/m	dBuV/m	dB
1	1260.149	3.69	25.04	38.35	41.24	31.62	68.20	-36.58 peak
2	1560.673	4.15	26.96	38.40	40.51	33.22	74.00	-40.78 peak
3	4417.841	7.07	34.59	35.78	38.16	44.04	68.20	-24.16 peak
4 p	8764.146	11.51	36.96	37.37	39.74	50.84	68.20	-17.36 peak
5	11970.000	13.08	37.77	37.56	38.39	51.68	74.00	-22.32 peak
6	17955.000	15.12	44.12	37.65	31.27	52.86	74.00	-21.14 peak



Unless otherwise agreed in writing, this document is issued by the Company subject to its General Conditions of Service printed overleaf, available on request or accessible at <https://www.sgs.com/en/Terms-and-Conditions>. Attention is drawn to the limitation of liability, indemnification and jurisdiction issues defined therein. Any holder of this document is advised that information contained hereon reflects the Company's findings at the time of its intervention only and within the limits of Client's instructions, if any. The Company's sole responsibility is to its Client and this document does not exonerate parties to a transaction from exercising all their rights and obligations under the transaction documents. This document cannot be reproduced except in full, without prior written approval of the Company. Any unauthorized alteration, forgery or falsification of the content or appearance of this document is unlawful and offenders may be prosecuted to the fullest extent of the law. Unless otherwise stated the results shown in this test report refer only to the sample(s) tested and such sample(s) are retained for 30 days only.

Attention: To check the authenticity of testing /inspection report & certificate, please contact us at telephone: (86-755) 8307 1443, or email: CN.Doccheck@sgs.com

No.1 Workshop, M-10, Middle Section, Science & Technology Park, Nanshan District, Shenzhen, Guangdong, China 518057 t (86-755) 26012053 f (86-755) 26710594 www.sgsgroup.com.cn  
 中国·广东·深圳市南山区科技园中区M-10栋1号厂房 邮编: 518057 t (86-755) 26012053 f (86-755) 26710594 sgs.china@sgs.com



Polarity: Vertical; Modulation:802.11ax(Full RU0); Bandwidth:80MHz; Channel:Low

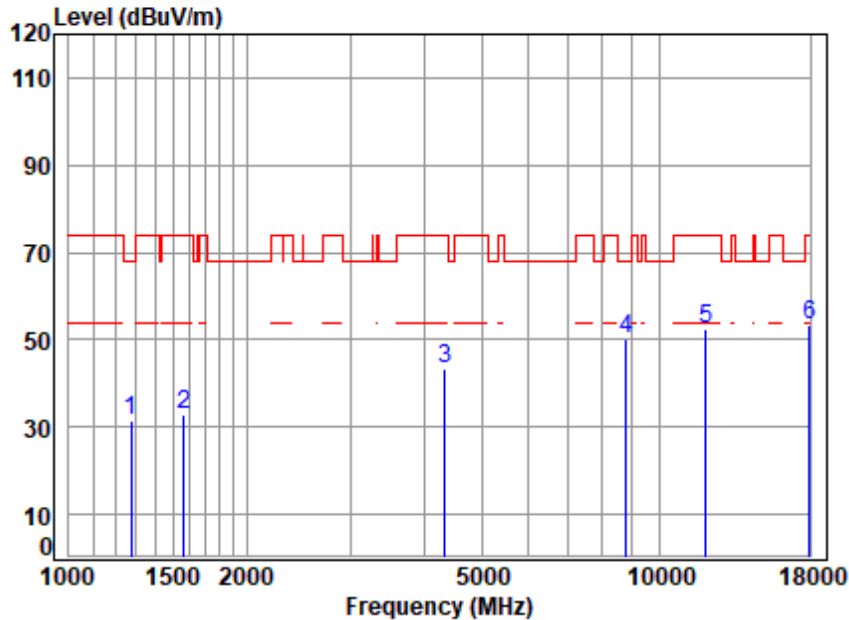

Site : chamber  
 Condition: 3m VERTICAL  
 Job No : 00384AT/00385AT  
 Mode : 5985 TX RSE  
 Note : 6E WIFI 11AX80

	Freq	Cable Loss	Ant Factor	Preamp Factor	Read Level	Limit Level	Over Line	Over Limit	Remark
	MHz	dB	dB/m	dB	dBuV	dBuV/m	dBuV/m	dB	
1	1274.802	3.71	24.95	38.35	41.38	31.69	68.20	-36.51	peak
2	1565.191	4.15	26.94	38.40	40.23	32.92	74.00	-41.08	peak
3	4329.354	7.01	34.23	35.85	37.90	43.29	74.00	-30.71	peak
4 p	8789.516	11.55	37.06	37.40	39.05	50.26	68.20	-17.94	peak
5	11970.000	13.08	37.77	37.56	39.07	52.36	74.00	-21.64	peak
6	17955.000	15.12	44.12	37.65	31.83	53.42	74.00	-20.58	peak



Unless otherwise agreed in writing, this document is issued by the Company subject to its General Conditions of Service printed overleaf, available on request or accessible at <https://www.sgs.com/en/Terms-and-Conditions>. Attention is drawn to the limitation of liability, indemnification and jurisdiction issues defined therein. Any holder of this document is advised that information contained hereon reflects the Company's findings at the time of its intervention only and within the limits of Client's instructions, if any. The Company's sole responsibility is to its Client and this document does not exonerate parties to a transaction from exercising all their rights and obligations under the transaction documents. This document cannot be reproduced except in full, without prior written approval of the Company. Any unauthorized alteration, forgery or falsification of the content or appearance of this document is unlawful and offenders may be prosecuted to the fullest extent of the law. Unless otherwise stated the results shown in this test report refer only to the sample(s) tested and such sample(s) are retained for 30 days only.

Attention: To check the authenticity of testing /inspection report & certificate, please contact us at telephone: (86-755) 8307 1443, or email: CN.Doccheck@sgs.com  
 No.1 Workshop, M-10, Middle Section, Science & Technology Park, Nanshan District, Shenzhen, Guangdong, China 518057 t (86-755) 26012053 f (86-755) 26710594 www.sgs.com.cn  
 中国·广东·深圳市南山区科技园中区M-10栋1号厂房 邮编: 518057 t (86-755) 26012053 f (86-755) 26710594 sgs.china@sgs.com

Polarity: Horizontal; Modulation:802.11ax(Full RU0); Bandwidth:80MHz; Channel:middle

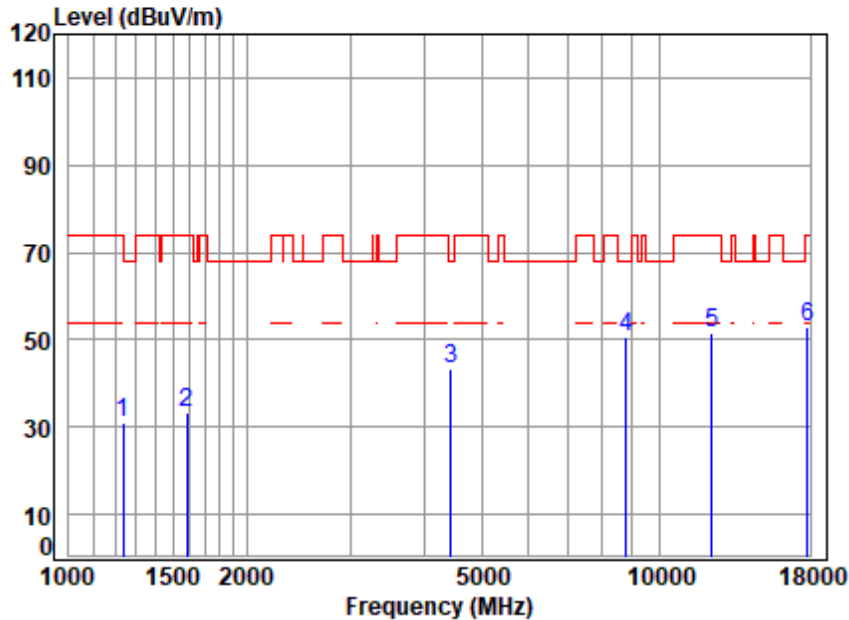

Site : chamber  
 Condition: 3m HORIZONTAL  
 Job No : 00384AT/00385AT  
 Mode : 6145 TX RSE  
 Note : 6E WIFI 11AX80

	Freq	Cable Loss	Ant Factor	Preamp Factor	Read Level	Limit Level	Over Line	Over Limit	Remark
	MHz	dB	dB/m	dB	dBuV	dBuV/m	dBuV/m	dB	
1	1238.483	3.65	24.94	38.35	40.87	31.11	74.00	-42.89	peak
2	1587.975	4.18	26.85	38.40	40.78	33.41	74.00	-40.59	peak
3	4443.453	7.09	34.28	35.77	37.89	43.49	68.20	-24.71	peak
4 p	8789.516	11.55	37.06	37.40	39.32	50.53	68.20	-17.67	peak
5	12290.000	13.23	37.90	37.47	38.08	51.74	74.00	-22.26	peak
6	17793.090	15.03	43.89	37.63	31.64	52.93	74.00	-21.07	peak



Unless otherwise agreed in writing, this document is issued by the Company subject to its General Conditions of Service printed overleaf, available on request or accessible at <https://www.sgs.com/en/Terms-and-Conditions>. Attention is drawn to the limitation of liability, indemnification and jurisdiction issues defined therein. Any holder of this document is advised that information contained hereon reflects the Company's findings at the time of its intervention only and within the limits of Client's instructions, if any. The Company's sole responsibility is to its Client and this document does not exonerate parties to a transaction from exercising all their rights and obligations under the transaction documents. This document cannot be reproduced except in full, without prior written approval of the Company. Any unauthorized alteration, forgery or falsification of the content or appearance of this document is unlawful and offenders may be prosecuted to the fullest extent of the law. Unless otherwise stated the results shown in this test report refer only to the sample(s) tested and such sample(s) are retained for 30 days only.

Attention: To check the authenticity of testing /inspection report & certificate, please contact us at telephone: (86-755) 8307 1443, or email: CN.Doccheck@sgs.com  
 No.1 Workshop, M-10, Middle Section, Science & Technology Park, Nanshan District, Shenzhen, Guangdong, China 518057 t (86-755) 26012053 f (86-755) 26710594 www.sgs.com.cn  
 中国·广东·深圳市南山区科技园中区M-10栋1号厂房 邮编: 518057 t (86-755) 26012053 f (86-755) 26710594 sgs.china@sgs.com

Polarity: Vertical; Modulation:802.11ax(Full RU0); Bandwidth:80MHz; Channel:middle

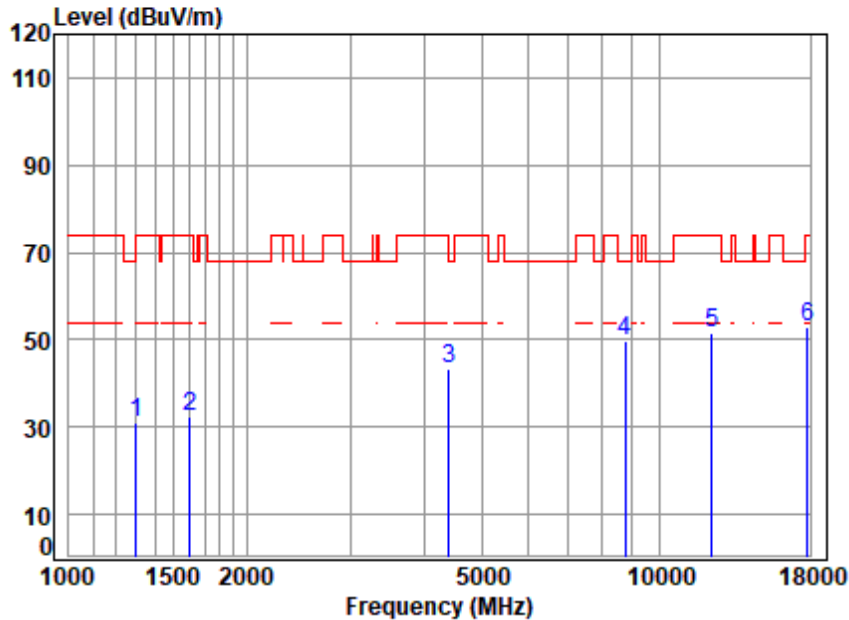

Site : chamber  
 Condition: 3m VERTICAL  
 Job No : 00384AT/00385AT  
 Mode : 6145 TX RSE  
 Note : 6E WIFI 11AX80

	Freq	Cable Loss	Ant Factor	Preamp Factor	Read Level	Limit Level	Over Limit	Remark
	MHz	dB	dB/m	dB	dBuV	dBuV/m	dBuV/m	dB
1	1300.858	3.76	24.79	38.36	40.85	31.04	74.00	-42.96 peak
2	1606.441	4.21	26.74	38.40	40.01	32.56	74.00	-41.44 peak
3	4405.090	7.06	34.74	35.79	37.34	43.35	68.20	-24.85 peak
4 p	8764.146	11.51	36.96	37.37	38.68	49.78	68.20	-18.42 peak
5	12290.000	13.23	37.90	37.47	37.77	51.43	74.00	-22.57 peak
6	17844.590	15.06	43.90	37.64	31.74	53.06	74.00	-20.94 peak



Unless otherwise agreed in writing, this document is issued by the Company subject to its General Conditions of Service printed overleaf, available on request or accessible at <https://www.sgs.com/en/Terms-and-Conditions>. Attention is drawn to the limitation of liability, indemnification and jurisdiction issues defined therein. Any holder of this document is advised that information contained hereon reflects the Company's findings at the time of its intervention only and within the limits of Client's instructions, if any. The Company's sole responsibility is to its Client and this document does not exonerate parties to a transaction from exercising all their rights and obligations under the transaction documents. This document cannot be reproduced except in full, without prior written approval of the Company. Any unauthorized alteration, forgery or falsification of the content or appearance of this document is unlawful and offenders may be prosecuted to the fullest extent of the law. Unless otherwise stated the results shown in this test report refer only to the sample(s) tested and such sample(s) are retained for 30 days only.

Attention: To check the authenticity of testing /inspection report & certificate, please contact us at telephone: (86-755) 8307 1443, or email: CN.Doccheck@sgs.com  
 No.1 Workshop, M-10, Middle Section, Science & Technology Park, Nanshan District, Shenzhen, Guangdong, China 518057 t (86-755) 26012053 f (86-755) 26710594 www.sgsgroup.com.cn  
 中国·广东·深圳市南山区科技园中区M-10栋1号厂房 邮编: 518057 t (86-755) 26012053 f (86-755) 26710594 sgs.china@sgs.com



Polarity: Horizontal; Modulation:802.11ax(Full RU0); Bandwidth:80MHz; Channel:High

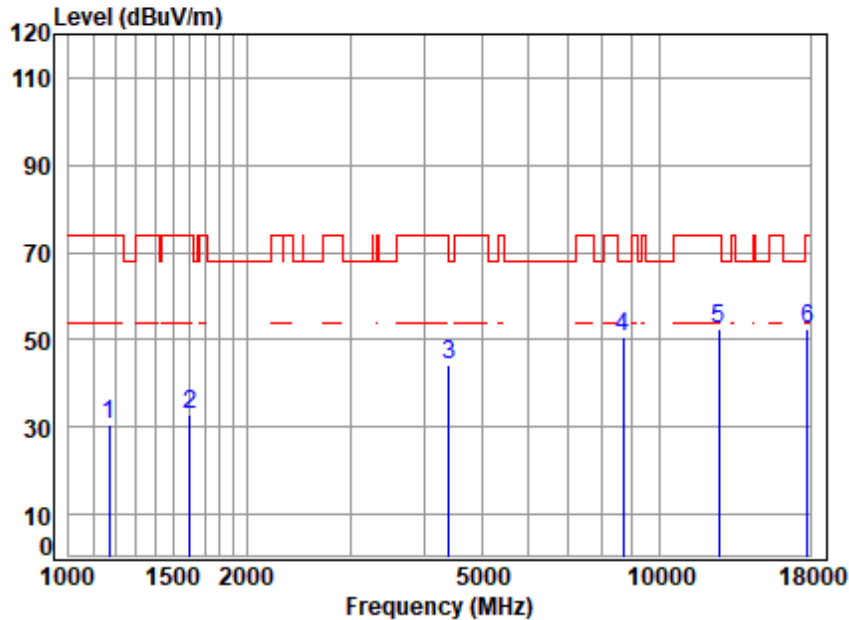

Site : chamber  
 Condition: 3m HORIZONTAL  
 Job No : 00384AT/00385AT  
 Mode : 6305 TX RSE  
 Note : 6E WIFI 11AX80

	Freq	Cable Loss	Ant Factor	Preamp Factor	Read Level	Limit Level	Over Line	Over Limit	Remark
	MHz	dB	dB/m	dB	dBuV	dBuV/m	dBuV/m	dB	
1	1168.920	3.53	24.09	38.33	41.33	30.62	74.00	-43.38	peak
2	1601.804	4.20	26.78	38.40	40.36	32.94	74.00	-41.06	peak
3	4405.090	7.06	34.74	35.79	38.05	44.06	68.20	-24.14	peak
4 p	8688.480	11.38	36.90	37.30	39.88	50.86	68.20	-17.34	peak
5	12610.000	13.37	37.92	37.38	38.35	52.26	74.00	-21.74	peak
6	17793.090	15.03	43.89	37.63	31.36	52.65	74.00	-21.35	peak



Unless otherwise agreed in writing, this document is issued by the Company subject to its General Conditions of Service printed overleaf, available on request or accessible at <https://www.sgs.com/en/Terms-and-Conditions>. Attention is drawn to the limitation of liability, indemnification and jurisdiction issues defined therein. Any holder of this document is advised that information contained hereon reflects the Company's findings at the time of its intervention only and within the limits of Client's instructions, if any. The Company's sole responsibility is to its Client and this document does not exonerate parties to a transaction from exercising all their rights and obligations under the transaction documents. This document cannot be reproduced except in full, without prior written approval of the Company. Any unauthorized alteration, forgery or falsification of the content or appearance of this document is unlawful and offenders may be prosecuted to the fullest extent of the law. Unless otherwise stated the results shown in this test report refer only to the sample(s) tested and such sample(s) are retained for 30 days only.  
 Attention: To check the authenticity of testing /inspection report & certificate, please contact us at telephone: (86-755) 8307 1443, or email: CN.Doccheck@sgs.com  
 No.1 Workshop, M-10, Middle Section, Science & Technology Park, Nanshan District, Shenzhen, Guangdong, China 518057 t (86-755) 26012053 f (86-755) 26710594 www.sgs.com.cn  
 中国·广东·深圳市南山区科技园中区M-10栋1号厂房 邮编: 518057 t (86-755) 26012053 f (86-755) 26710594 sgs.china@sgs.com

Polarity: Vertical; Modulation:802.11ax(Full RU0); Bandwidth:80MHz; Channel:High

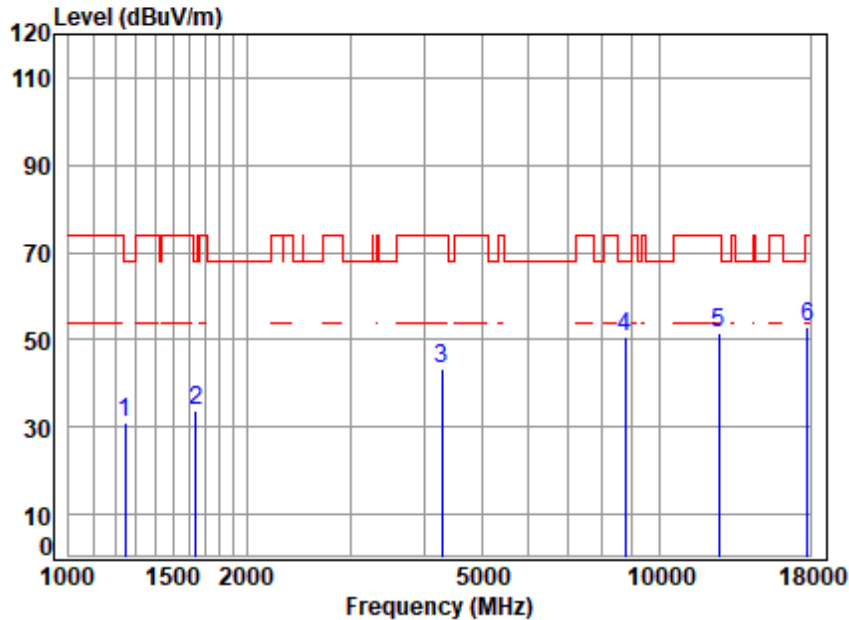

Site : chamber  
 Condition: 3m VERTICAL  
 Job No : 00384AT/00385AT  
 Mode : 6305 TX RSE  
 Note : 6E WIFI 11AX80

	Freq	Cable Loss	Ant Factor	Preamp Factor	Read Level	Limit Level	Over Limit	Remark
	MHz	dB	dB/m	dB	dBuV	dBuV/m	dBuV/m	dB
1	1245.663	3.66	25.04	38.35	40.87	68.20	-36.98	peak
2	1644.019	4.26	26.36	38.41	41.39	68.20	-34.60	peak
3	4279.589	6.98	33.92	35.89	38.44	74.00	-30.55	peak
4 p	8764.146	11.51	36.96	37.37	39.41	68.20	-17.69	peak
5	12610.000	13.37	37.92	37.38	37.56	74.00	-22.53	peak
6	17844.590	15.06	43.90	37.64	31.70	74.00	-20.98	peak



Unless otherwise agreed in writing, this document is issued by the Company subject to its General Conditions of Service printed overleaf, available on request or accessible at <https://www.sgs.com/en/Terms-and-Conditions>. Attention is drawn to the limitation of liability, indemnification and jurisdiction issues defined therein. Any holder of this document is advised that information contained hereon reflects the Company's findings at the time of its intervention only and within the limits of Client's instructions, if any. The Company's sole responsibility is to its Client and this document does not exonerate parties to a transaction from exercising all their rights and obligations under the transaction documents. This document cannot be reproduced except in full, without prior written approval of the Company. Any unauthorized alteration, forgery or falsification of the content or appearance of this document is unlawful and offenders may be prosecuted to the fullest extent of the law. Unless otherwise stated the results shown in this test report refer only to the sample(s) tested and such sample(s) are retained for 30 days only.  
 Attention: To check the authenticity of testing /inspection report & certificate, please contact us at telephone: (86-755) 8307 1443, or email: CN.Doccheck@sgs.com  
 No.1 Workshop, M-10, Middle Section, Science & Technology Park, Nanshan District, Shenzhen, Guangdong, China 518057 t (86-755) 26012053 f (86-755) 26710594 www.sgs.com.cn  
 中国·广东·深圳市南山区科技园中区M-10栋1号厂房 邮编: 518057 t (86-755) 26012053 f (86-755) 26710594 sgs.china@sgs.com

Polarity: Horizontal; Modulation:802.11ax(Full RU0); Bandwidth:160MHz; Channel:Low

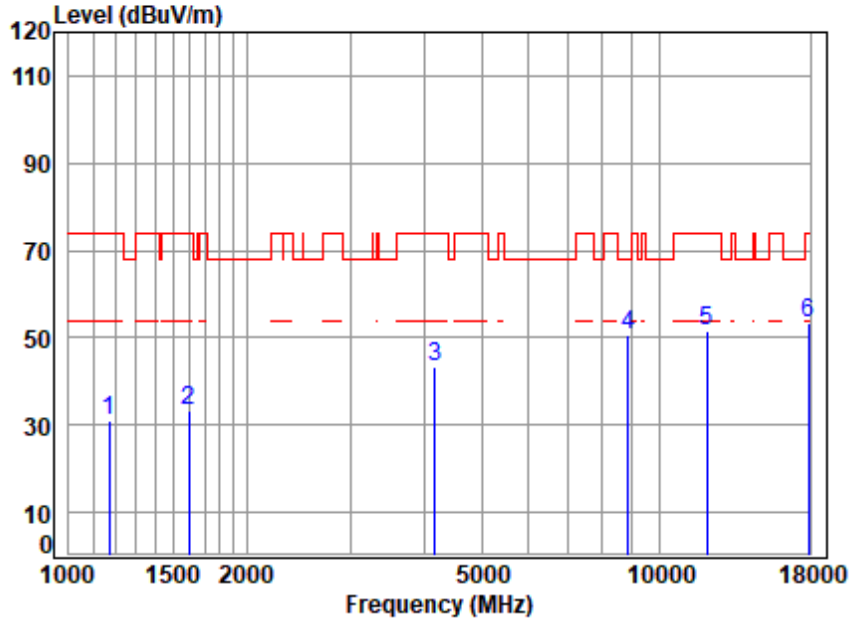

Site : chamber  
 Condition: 3m HORIZONTAL  
 Job No : 00384AT/00385AT  
 Mode : 6025 TX RSE  
 Note : 6E WIFI 11AX160

	Freq	Cable Loss	Ant Factor	Preamp Factor	Read Level	Limit Level	Over Limit	Remark
	MHz	dB	dB/m	dB	dBuV	dBuV/m	dBuV/m	dB
1	1172.303	3.53	24.12	38.33	41.93	31.25	74.00	-42.75 peak
2	1597.181	4.20	26.81	38.40	40.60	33.21	74.00	-40.79 peak
3	4169.698	6.90	33.80	35.97	38.63	43.36	74.00	-30.64 peak
4 p	8866.062	11.69	37.20	37.48	39.25	50.66	68.20	-17.54 peak
5	12050.000	13.11	37.75	37.54	38.17	51.49	74.00	-22.51 peak
6	17896.250	15.09	43.90	37.64	31.96	53.31	74.00	-20.69 peak



Unless otherwise agreed in writing, this document is issued by the Company subject to its General Conditions of Service printed overleaf, available on request or accessible at <https://www.sgs.com/en/Terms-and-Conditions>. Attention is drawn to the limitation of liability, indemnification and jurisdiction issues defined therein. Any holder of this document is advised that information contained hereon reflects the Company's findings at the time of its intervention only and within the limits of Client's instructions, if any. The Company's sole responsibility is to its Client and this document does not exonerate parties to a transaction from exercising all their rights and obligations under the transaction documents. This document cannot be reproduced except in full, without prior written approval of the Company. Any unauthorized alteration, forgery or falsification of the content or appearance of this document is unlawful and offenders may be prosecuted to the fullest extent of the law. Unless otherwise stated the results shown in this test report refer only to the sample(s) tested and such sample(s) are retained for 30 days only.  
 Attention: To check the authenticity of testing /inspection report & certificate, please contact us at telephone: (86-755) 8307 1443, or email: CN.Doccheck@sgs.com  
 No.1 Workshop, M-10, Middle Section, Science & Technology Park, Nanshan District, Shenzhen, Guangdong, China 518057 t (86-755) 26012053 f (86-755) 26710594 www.sgsgroup.com.cn  
 中国·广东·深圳市南山区科技园中区M-10栋1号厂房 邮编: 518057 t (86-755) 26012053 f (86-755) 26710594 sgs.china@sgs.com



Polarity: Vertical; Modulation:802.11ax(Full RU0); Bandwidth:160MHz; Channel:Low

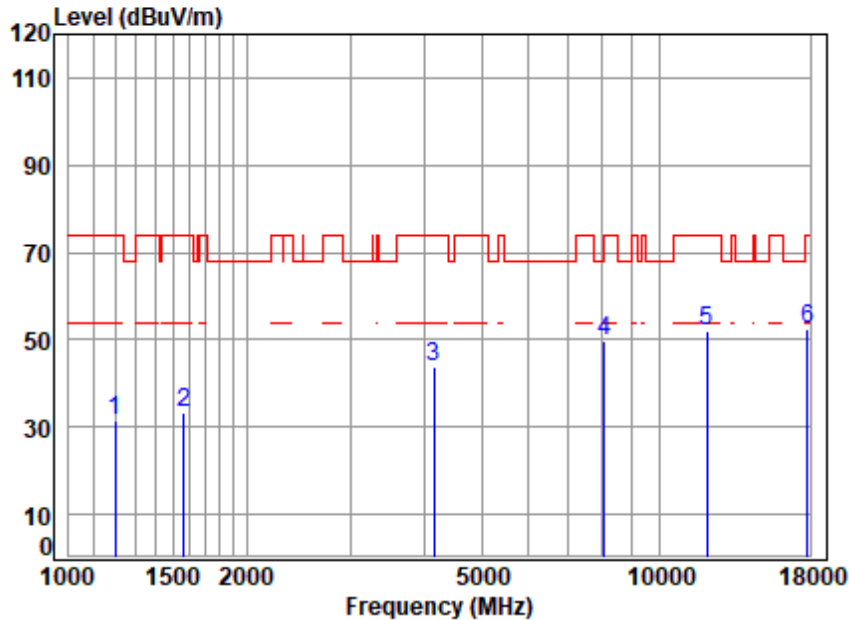

Site : chamber  
 Condition: 3m VERTICAL  
 Job No : 00384AT/00385AT  
 Mode : 6025 TX RSE  
 Note : 6E WIFI 11AX160

	Freq	Cable Loss	Ant Factor	Preamp Factor	Read Level	Limit Level	Over Line	Over Limit	Remark
	MHz	dB	dB/m	dB	dBuV	dBuV/m	dBuV/m	dB	
1	1199.726	3.58	24.40	38.34	41.92	31.56	74.00	-42.44	peak
2	1565.191	4.15	26.94	38.40	40.71	33.40	74.00	-40.60	peak
3	4157.664	6.89	33.80	35.98	39.02	43.73	74.00	-30.27	peak
4	8082.804	10.26	36.47	36.65	39.56	49.64	74.00	-24.36	peak
5	12050.000	13.11	37.75	37.54	38.68	52.00	74.00	-22.00	peak
6	p17793.090	15.03	43.89	37.63	31.04	52.33	74.00	-21.67	peak



Unless otherwise agreed in writing, this document is issued by the Company subject to its General Conditions of Service printed overleaf, available on request or accessible at <https://www.sgs.com/en/Terms-and-Conditions>. Attention is drawn to the limitation of liability, indemnification and jurisdiction issues defined therein. Any holder of this document is advised that information contained hereon reflects the Company's findings at the time of its intervention only and within the limits of Client's instructions, if any. The Company's sole responsibility is to its Client and this document does not exonerate parties to a transaction from exercising all their rights and obligations under the transaction documents. This document cannot be reproduced except in full, without prior written approval of the Company. Any unauthorized alteration, forgery or falsification of the content or appearance of this document is unlawful and offenders may be prosecuted to the fullest extent of the law. Unless otherwise stated the results shown in this test report refer only to the sample(s) tested and such sample(s) are retained for 30 days only.

Attention: To check the authenticity of testing /inspection report & certificate, please contact us at telephone: (86-755) 8307 1443, or email: CN.Doccheck@sgs.com  
 No.1 Workshop, M-10, Middle Section, Science & Technology Park, Nanshan District, Shenzhen, Guangdong, China 518057 t (86-755) 26012053 f (86-755) 26710594 www.sgs.com.cn  
 中国·广东·深圳市南山区科技园中区M-10栋1号厂房 邮编: 518057 t (86-755) 26012053 f (86-755) 26710594 sgs.china@sgs.com

Polarity: Horizontal; Modulation:802.11ax(Full RU0); Bandwidth:160MHz; Channel:High

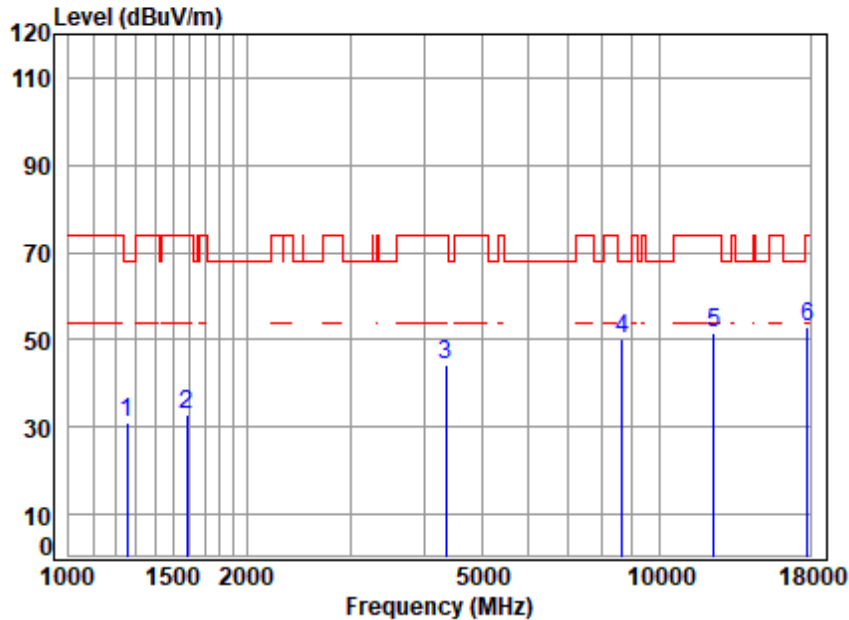

Site : chamber  
 Condition: 3m HORIZONTAL  
 Job No : 00384AT/00385AT  
 Mode : 6185 TX RSE  
 Note : 6E WIFI 11AX160

	Freq	Cable Loss	Ant Factor	Preamp Factor	Read Level	Limit Level	Over Limit	Remark
	MHz	dB	dB/m	dB	dBuV	dBuV/m	dBuV/m	dB
1	1256.512	3.68	25.06	38.35	40.79	31.18	68.20	-37.02 peak
2	1583.392	4.18	26.87	38.40	40.40	33.05	74.00	-40.95 peak
3	4354.454	7.03	34.44	35.83	38.72	44.36	74.00	-29.64 peak
4 p	8663.404	11.33	36.90	37.27	39.03	49.99	68.20	-18.21 peak
5	12370.000	13.26	37.90	37.44	37.94	51.66	74.00	-22.34 peak
6	17793.090	15.03	43.89	37.63	31.74	53.03	74.00	-20.97 peak



Unless otherwise agreed in writing, this document is issued by the Company subject to its General Conditions of Service printed overleaf, available on request or accessible at <https://www.sgs.com/en/Terms-and-Conditions>. Attention is drawn to the limitation of liability, indemnification and jurisdiction issues defined therein. Any holder of this document is advised that information contained hereon reflects the Company's findings at the time of its intervention only and within the limits of Client's instructions, if any. The Company's sole responsibility is to its Client and this document does not exonerate parties to a transaction from exercising all their rights and obligations under the transaction documents. This document cannot be reproduced except in full, without prior written approval of the Company. Any unauthorized alteration, forgery or falsification of the content or appearance of this document is unlawful and offenders may be prosecuted to the fullest extent of the law. Unless otherwise stated the results shown in this test report refer only to the sample(s) tested and such sample(s) are retained for 30 days only.  
 Attention: To check the authenticity of testing /inspection report & certificate, please contact us at telephone: (86-755) 8307 1443, or email: CN.Doccheck@sgs.com  
 No.1 Workshop, M-10, Middle Section, Science & Technology Park, Nanshan District, Shenzhen, Guangdong, China 518057 t (86-755) 26012053 f (86-755) 26710594 www.sgsgroup.com.cn  
 中国·广东·深圳市南山区科技园中区M-10栋1号厂房 邮编: 518057 t (86-755) 26012053 f (86-755) 26710594 sgs.china@sgs.com

Polarity: Vertical; Modulation:802.11ax(Full RU0); Bandwidth:160MHz; Channel:High

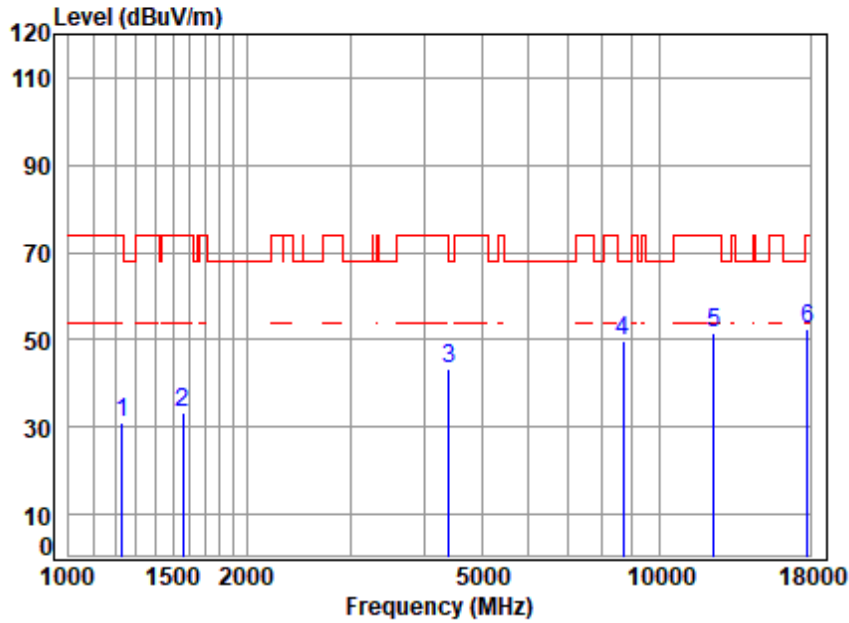

Site : chamber  
 Condition: 3m VERTICAL  
 Job No : 00384AT/00385AT  
 Mode : 6185 TX RSE  
 Note : 6E WIFI 11AX160

	Freq	Cable Loss	Ant Factor	Preamp Factor	Read Level	Limit Level	Over Limit	Remark
	MHz	dB	dB/m	dB	dBuV	dBuV/m	dBuV/m	dB
1	1231.345	3.64	24.84	38.35	40.75	30.88	74.00	-43.12 peak
2	1560.673	4.15	26.96	38.40	40.46	33.17	74.00	-40.83 peak
3	4405.090	7.06	34.74	35.79	37.12	43.13	68.20	-25.07 peak
4 p	8688.480	11.38	36.90	37.30	38.84	49.82	68.20	-18.38 peak
5	12370.000	13.26	37.90	37.44	37.71	51.43	74.00	-22.57 peak
6	17793.090	15.03	43.89	37.63	31.27	52.56	74.00	-21.44 peak



Unless otherwise agreed in writing, this document is issued by the Company subject to its General Conditions of Service printed overleaf, available on request or accessible at <https://www.sgs.com/en/Terms-and-Conditions>. Attention is drawn to the limitation of liability, indemnification and jurisdiction issues defined therein. Any holder of this document is advised that information contained hereon reflects the Company's findings at the time of its intervention only and within the limits of Client's instructions, if any. The Company's sole responsibility is to its Client and this document does not exonerate parties to a transaction from exercising all their rights and obligations under the transaction documents. This document cannot be reproduced except in full, without prior written approval of the Company. Any unauthorized alteration, forgery or falsification of the content or appearance of this document is unlawful and offenders may be prosecuted to the fullest extent of the law. Unless otherwise stated the results shown in this test report refer only to the sample(s) tested and such sample(s) are retained for 30 days only.

Attention: To check the authenticity of testing /inspection report & certificate, please contact us at telephone: (86-755) 8307 1443, or email: CN.Doccheck@sgs.com  
 No.1 Workshop, M-10, Middle Section, Science & Technology Park, Nanshan District, Shenzhen, Guangdong, China 518057 t (86-755) 26012053 f (86-755) 26710594 www.sgs.com.cn  
 中国·广东·深圳市南山区科技园中区M-10栋1号厂房 邮编: 518057 t (86-755) 26012053 f (86-755) 26710594 sgs.china@sgs.com



Polarity: Horizontal; Modulation:802.11ax(Full RU0); Bandwidth:20MHz; Channel:Low

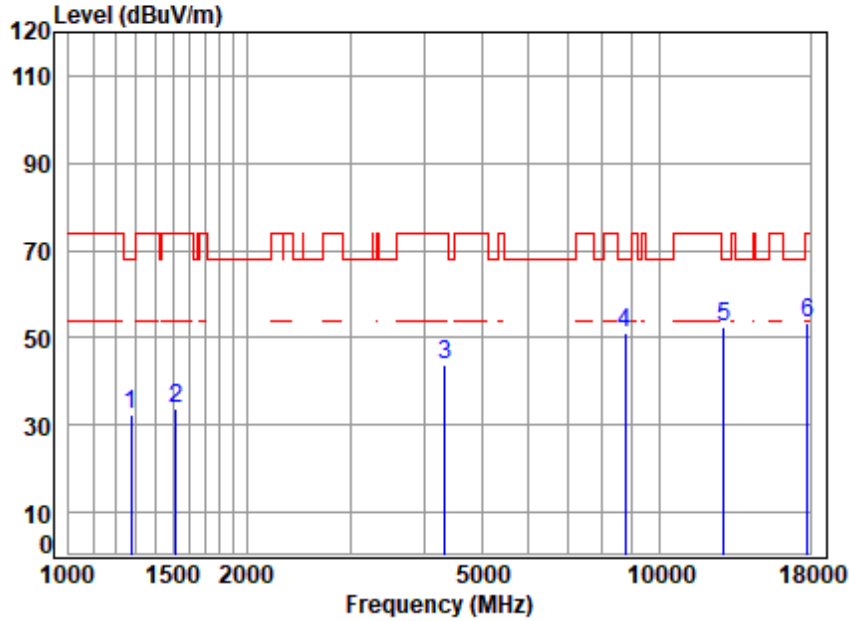

Site : chamber  
 Condition: 3m HORIZONTAL  
 Job No : 00384AT/00385AT  
 Mode : 6435 TX RSE  
 Note : 6E WIFI 11AX20

	Freq	Cable Loss	Ant Factor	Preamp Factor	Read Level	Limit Level	Over Limit	Remark
	MHz	dB	dB/m	dB	dBuV	dBuV/m	dBuV/m	dB
1	1274.802	3.71	24.95	38.35	42.28	32.59	68.20	-35.61 peak
2	1516.210	4.08	26.86	38.39	41.07	33.62	74.00	-40.38 peak
3	4341.886	7.02	34.34	35.84	38.19	43.71	74.00	-30.29 peak
4	8738.852	11.47	36.90	37.35	39.92	50.94	68.20	-17.26 peak
5	12870.000	13.49	38.17	37.31	38.00	52.35	68.20	-15.85 peak
6	17793.090	15.03	43.89	37.63	32.14	53.43	74.00	-20.57 peak



Unless otherwise agreed in writing, this document is issued by the Company subject to its General Conditions of Service printed overleaf, available on request or accessible at <https://www.sgs.com/en/Terms-and-Conditions>. Attention is drawn to the limitation of liability, indemnification and jurisdiction issues defined therein. Any holder of this document is advised that information contained hereon reflects the Company's findings at the time of its intervention only and within the limits of Client's instructions, if any. The Company's sole responsibility is to its Client and this document does not exonerate parties to a transaction from exercising all their rights and obligations under the transaction documents. This document cannot be reproduced except in full, without prior written approval of the Company. Any unauthorized alteration, forgery or falsification of the content or appearance of this document is unlawful and offenders may be prosecuted to the fullest extent of the law. Unless otherwise stated the results shown in this test report refer only to the sample(s) tested and such sample(s) are retained for 30 days only.

Attention: To check the authenticity of testing /inspection report & certificate, please contact us at telephone: (86-755) 8307 1443, or email: CN.Doccheck@sgs.com  
 No.1 Workshop, M-10, Middle Section, Science & Technology Park, Nanshan District, Shenzhen, Guangdong, China 518057 t (86-755) 26012053 f (86-755) 26710594 www.sgs.com.cn  
 中国·广东·深圳市南山区科技园中区M-10栋1号厂房 邮编: 518057 t (86-755) 26012053 f (86-755) 26710594 sgs.china@sgs.com

Polarity: Vertical; Modulation:802.11ax(Full RU0); Bandwidth:20MHz; Channel:Low

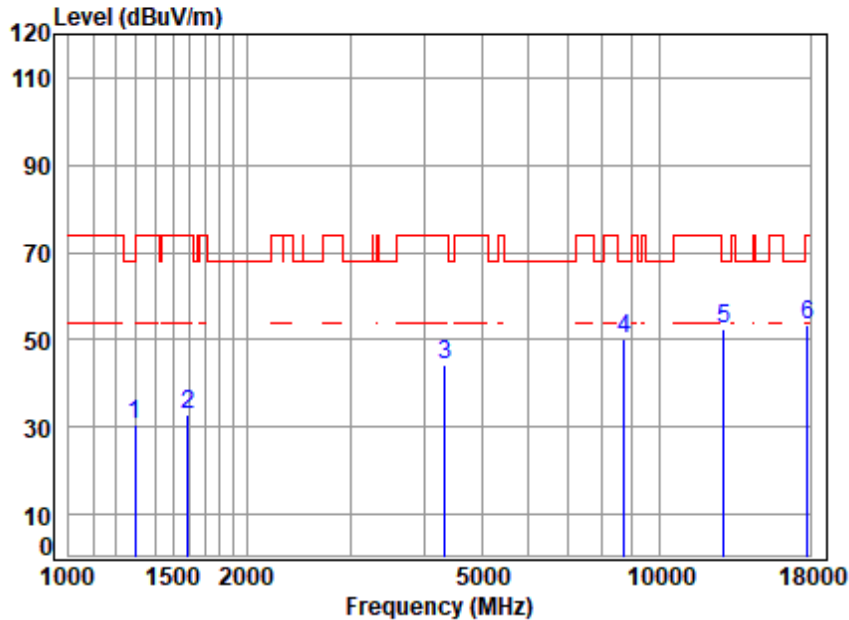

Site : chamber  
 Condition: 3m VERTICAL  
 Job No : 00384AT/00385AT  
 Mode : 6435 TX RSE  
 Note : 6E WIFI 11AX20

	Freq	Cable Loss	Ant Factor	Preamp Factor	Read Level	Limit Level	Over Line	Over Limit	Remark
	MHz	dB	dB/m	dB	dBuV	dBuV/m	dBuV/m	dB	
1	1293.359	3.74	24.84	38.36	40.53	30.75	68.20	-37.45	peak
2	1592.571	4.19	26.83	38.40	40.03	32.65	74.00	-41.35	peak
3	4329.354	7.01	34.23	35.85	38.77	44.16	74.00	-29.84	peak
4	8713.630	11.42	36.90	37.32	39.09	50.09	68.20	-18.11	peak
5	12870.000	13.49	38.17	37.31	38.02	52.37	68.20	-15.83	peak
6	17844.590	15.06	43.90	37.64	32.08	53.40	74.00	-20.60	peak



Unless otherwise agreed in writing, this document is issued by the Company subject to its General Conditions of Service printed overleaf, available on request or accessible at <https://www.sgs.com/en/Terms-and-Conditions>. Attention is drawn to the limitation of liability, indemnification and jurisdiction issues defined therein. Any holder of this document is advised that information contained hereon reflects the Company's findings at the time of its intervention only and within the limits of Client's instructions, if any. The Company's sole responsibility is to its Client and this document does not exonerate parties to a transaction from exercising all their rights and obligations under the transaction documents. This document cannot be reproduced except in full, without prior written approval of the Company. Any unauthorized alteration, forgery or falsification of the content or appearance of this document is unlawful and offenders may be prosecuted to the fullest extent of the law. Unless otherwise stated the results shown in this test report refer only to the sample(s) tested and such sample(s) are retained for 30 days only.

Attention: To check the authenticity of testing /inspection report & certificate, please contact us at telephone: (86-755) 8307 1443, or email: CN.Doccheck@sgs.com  
 No.1 Workshop, M-10, Middle Section, Science & Technology Park, Nanshan District, Shenzhen, Guangdong, China 518057 t (86-755) 26012053 f (86-755) 26710594 www.sgsgroup.com.cn  
 中国·广东·深圳市南山区科技园中区M-10栋1号厂房 邮编: 518057 t (86-755) 26012053 f (86-755) 26710594 sgs.china@sgs.com

Polarity: Horizontal; Modulation:802.11ax(Full RU0); Bandwidth:20MHz; Channel:middle

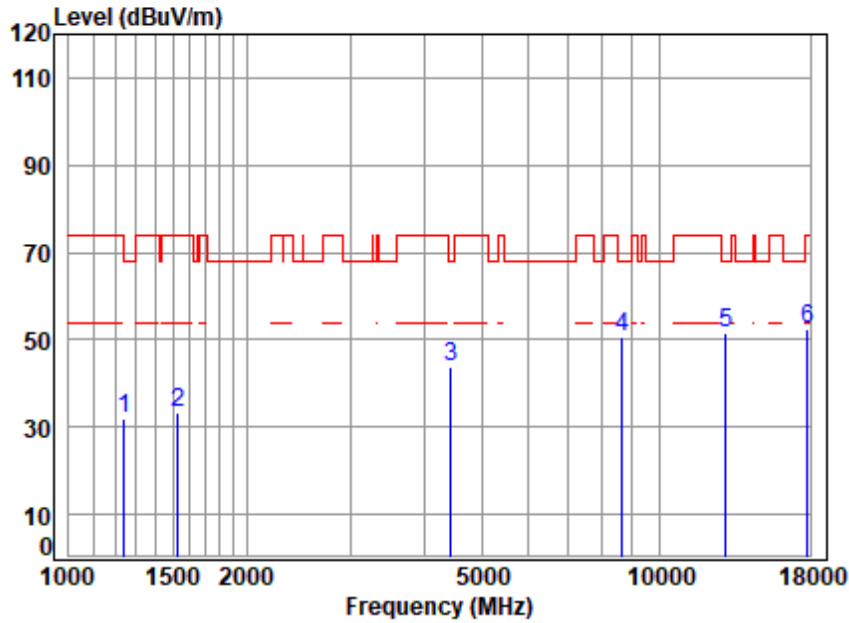

Site : chamber  
 Condition: 3m HORIZONTAL  
 Job No : 00384AT/00385AT  
 Mode : 6475 TX RSE  
 Note : 6E WIFI 11AX20

	Freq	Cable Loss	Ant Factor	Preamp Factor	Read Level	Limit Level	Over Limit	Remark
	MHz	dB	dB/m	dB	dBuV	dBuV/m	dBuV/m	dB
1	1242.068	3.66	24.99	38.35	41.49	31.79	68.20	-36.41 peak
2	1529.414	4.10	26.92	38.39	40.81	33.44	74.00	-40.56 peak
3	4443.453	7.09	34.28	35.77	38.41	44.01	68.20	-24.19 peak
4	8638.399	11.29	36.90	37.24	39.75	50.70	68.20	-17.50 peak
5	12950.000	13.53	38.15	37.28	37.36	51.76	68.20	-16.44 peak
6	17844.590	15.06	43.90	37.64	31.36	52.68	74.00	-21.32 peak



Unless otherwise agreed in writing, this document is issued by the Company subject to its General Conditions of Service printed overleaf, available on request or accessible at <https://www.sgs.com/en/Terms-and-Conditions>. Attention is drawn to the limitation of liability, indemnification and jurisdiction issues defined therein. Any holder of this document is advised that information contained hereon reflects the Company's findings at the time of its intervention only and within the limits of Client's instructions, if any. The Company's sole responsibility is to its Client and this document does not exonerate parties to a transaction from exercising all their rights and obligations under the transaction documents. This document cannot be reproduced except in full, without prior written approval of the Company. Any unauthorized alteration, forgery or falsification of the content or appearance of this document is unlawful and offenders may be prosecuted to the fullest extent of the law. Unless otherwise stated the results shown in this test report refer only to the sample(s) tested and such sample(s) are retained for 30 days only.  
 Attention: To check the authenticity of testing /inspection report & certificate, please contact us at telephone: (86-755) 8307 1443, or email: CN.Doccheck@sgs.com  
 No.1 Workshop, M-10, Middle Section, Science & Technology Park, Nanshan District, Shenzhen, Guangdong, China 518057 t (86-755) 26012053 f (86-755) 26710594 www.sgs.com.cn  
 中国·广东·深圳市南山区科技园中区M-10栋1号厂房 邮编: 518057 t (86-755) 26012053 f (86-755) 26710594 sgs.china@sgs.com



Polarity: Vertical; Modulation:802.11ax(Full RU0); Bandwidth:20MHz; Channel:middle

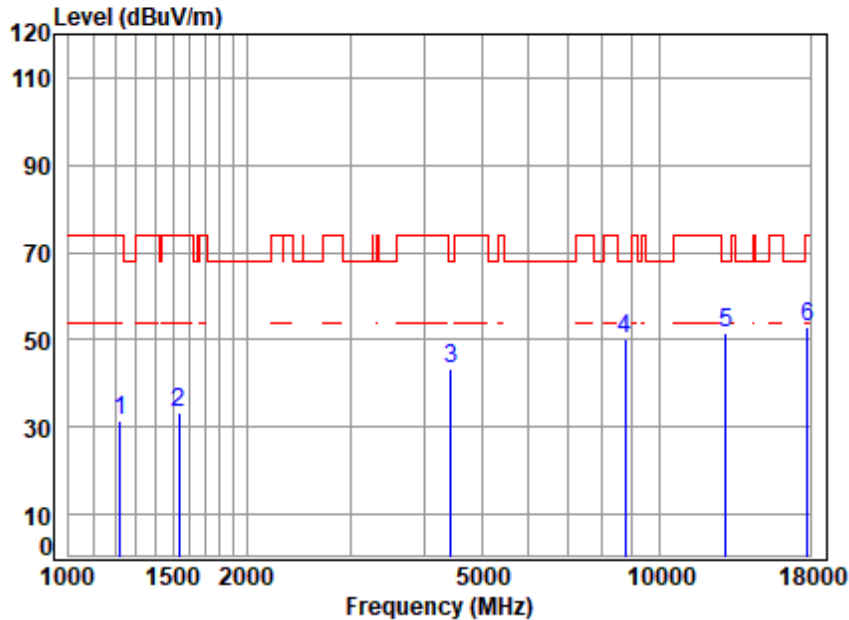

Site : chamber  
 Condition: 3m VERTICAL  
 Job No : 00384AT/00385AT  
 Mode : 6475 TX RSE  
 Note : 6E WIFI 11AX20

	Freq	Cable Loss	Ant Factor	Preamp Factor	Read Level	Limit Level	Over Limit	Remark
	MHz	dB	dB/m	dB	dBuV	dBuV/m	dBuV/m	dB
1	1224.247	3.62	24.74	38.34	41.25	31.27	74.00	-42.73 peak
2	1533.841	4.11	26.94	38.39	40.71	33.37	74.00	-40.63 peak
3	4430.628	7.08	34.43	35.77	37.77	43.51	68.20	-24.69 peak
4	8764.146	11.51	36.96	37.37	39.14	50.24	68.20	-17.96 peak
5	12950.000	13.53	38.15	37.28	37.29	51.69	68.20	-16.51 peak
6	17844.590	15.06	43.90	37.64	31.39	52.71	74.00	-21.29 peak



Unless otherwise agreed in writing, this document is issued by the Company subject to its General Conditions of Service printed overleaf, available on request or accessible at <https://www.sgs.com/en/Terms-and-Conditions>. Attention is drawn to the limitation of liability, indemnification and jurisdiction issues defined therein. Any holder of this document is advised that information contained hereon reflects the Company's findings at the time of its intervention only and within the limits of Client's instructions, if any. The Company's sole responsibility is to its Client and this document does not exonerate parties to a transaction from exercising all their rights and obligations under the transaction documents. This document cannot be reproduced except in full, without prior written approval of the Company. Any unauthorized alteration, forgery or falsification of the content or appearance of this document is unlawful and offenders may be prosecuted to the fullest extent of the law. Unless otherwise stated the results shown in this test report refer only to the sample(s) tested and such sample(s) are retained for 30 days only.

Attention: To check the authenticity of testing /inspection report & certificate, please contact us at telephone: (86-755) 8307 1443, or email: CN.Doccheck@sgs.com  
 No.1 Workshop, M-10, Middle Section, Science & Technology Park, Nanshan District, Shenzhen, Guangdong, China 518057 t (86-755) 26012053 f (86-755) 26710594 www.sgs.com.cn  
 中国·广东·深圳市南山区科技园中区M-10栋1号厂房 邮编: 518057 t (86-755) 26012053 f (86-755) 26710594 sgs.china@sgs.com

Polarity: Horizontal; Modulation:802.11ax(Full RU0); Bandwidth:20MHz; Channel:High

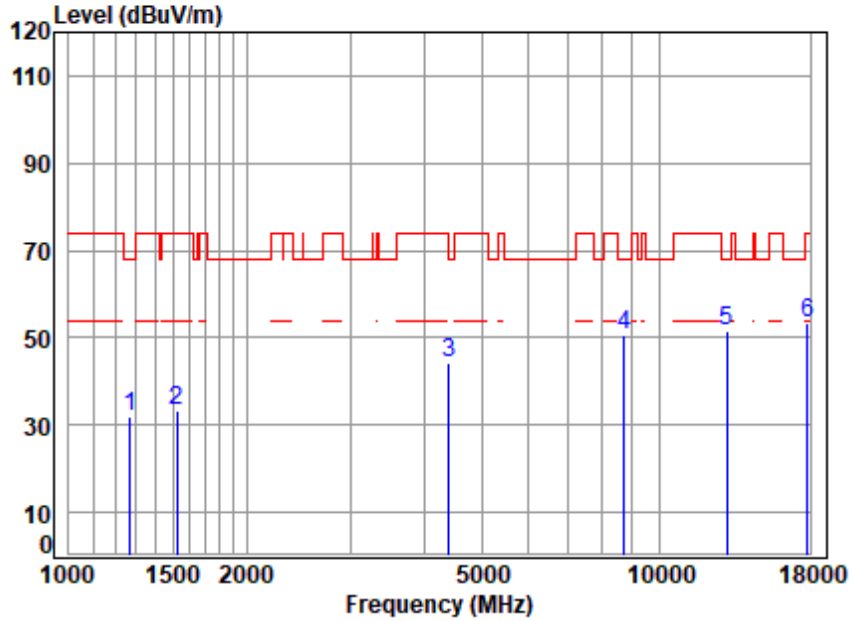

Site : chamber  
 Condition: 3m HORIZONTAL  
 Job No : 00384AT/00385AT  
 Mode : 6495 TX RSE  
 Note : 6E WIFI 11AX20

	Freq	Cable Loss	Ant Factor	Preamp Factor	Read Level	Limit Level	Over Line	Over Limit	Remark
	MHz	dB	dB/m	dB	dBuV	dBuV/m	dBuV/m	dB	
1	1271.123	3.71	24.97	38.35	41.76	32.09	68.20	-36.11	peak
2	1525.000	4.10	26.90	38.39	40.57	33.18	74.00	-40.82	peak
3	4405.090	7.06	34.74	35.79	38.17	44.18	68.20	-24.02	peak
4	8713.630	11.42	36.90	37.32	39.81	50.81	68.20	-17.39	peak
5	12990.000	13.55	38.11	37.27	37.36	51.75	68.20	-16.45	peak
6	17844.590	15.06	43.90	37.64	32.06	53.38	74.00	-20.62	peak



Unless otherwise agreed in writing, this document is issued by the Company subject to its General Conditions of Service printed overleaf, available on request or accessible at <https://www.sgs.com/en/Terms-and-Conditions>. Attention is drawn to the limitation of liability, indemnification and jurisdiction issues defined therein. Any holder of this document is advised that information contained hereon reflects the Company's findings at the time of its intervention only and within the limits of Client's instructions, if any. The Company's sole responsibility is to its Client and this document does not exonerate parties to a transaction from exercising all their rights and obligations under the transaction documents. This document cannot be reproduced except in full, without prior written approval of the Company. Any unauthorized alteration, forgery or falsification of the content or appearance of this document is unlawful and offenders may be prosecuted to the fullest extent of the law. Unless otherwise stated the results shown in this test report refer only to the sample(s) tested and such sample(s) are retained for 30 days only.

Attention: To check the authenticity of testing /inspection report & certificate, please contact us at telephone: (86-755) 8307 1443, or email: CN.Doccheck@sgs.com

No.1 Workshop, M-10, Middle Section, Science & Technology Park, Nanshan District, Shenzhen, Guangdong, China 518057 t (86-755) 26012053 f (86-755) 26710594 www.sgsgroup.com.cn  
 中国·广东·深圳市南山区科技园中区M-10栋1号厂房 邮编: 518057 t (86-755) 26012053 f (86-755) 26710594 sgs.china@sgs.com

Polarity: Vertical; Modulation:802.11ax(Full RU0); Bandwidth:20MHz; Channel:High

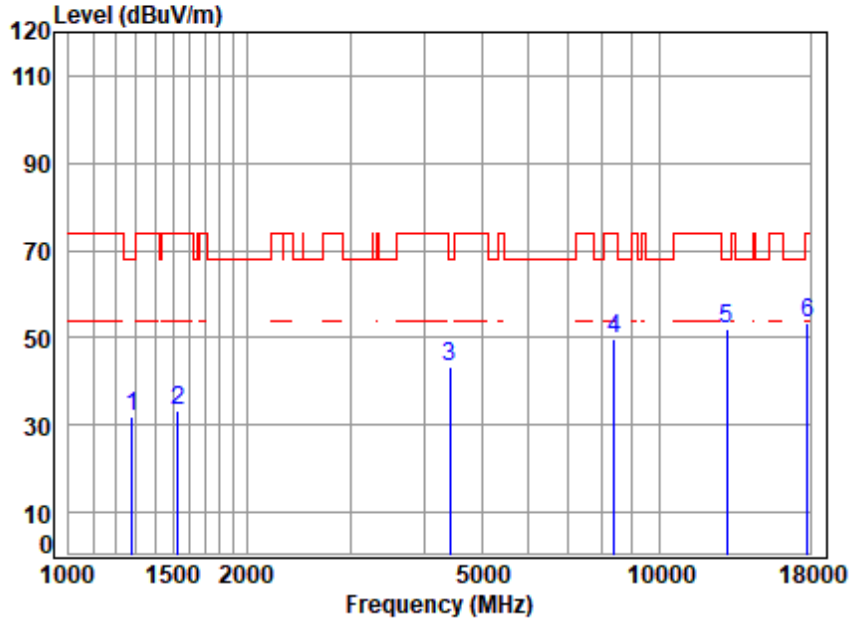

Site : chamber  
 Condition: 3m VERTICAL  
 Job No : 00384AT/00385AT  
 Mode : 6495 TX RSE  
 Note : 6E WIFI 11AX20

	Freq	Cable Loss	Ant Factor	Preamp Factor	Read Level	Limit Level	Over Limit	Remark
	MHz	dB	dB/m	dB	dBuV	dBuV/m	dBuV/m	dB
1	1278.492	3.72	24.93	38.35	41.70	32.00	68.20	-36.20 peak
2	1529.414	4.10	26.92	38.39	40.48	33.11	74.00	-40.89 peak
3	4417.841	7.07	34.59	35.78	37.32	43.20	68.20	-25.00 peak
4	8392.292	10.84	36.70	36.99	39.17	49.72	74.00	-24.28 peak
5	12990.000	13.55	38.11	37.27	37.49	51.88	68.20	-16.32 peak
6	17793.090	15.03	43.89	37.63	32.07	53.36	74.00	-20.64 peak



Unless otherwise agreed in writing, this document is issued by the Company subject to its General Conditions of Service printed overleaf, available on request or accessible at <https://www.sgs.com/en/Terms-and-Conditions>. Attention is drawn to the limitation of liability, indemnification and jurisdiction issues defined therein. Any holder of this document is advised that information contained hereon reflects the Company's findings at the time of its intervention only and within the limits of Client's instructions, if any. The Company's sole responsibility is to its Client and this document does not exonerate parties to a transaction from exercising all their rights and obligations under the transaction documents. This document cannot be reproduced except in full, without prior written approval of the Company. Any unauthorized alteration, forgery or falsification of the content or appearance of this document is unlawful and offenders may be prosecuted to the fullest extent of the law. Unless otherwise stated the results shown in this test report refer only to the sample(s) tested and such sample(s) are retained for 30 days only.

Attention: To check the authenticity of testing /inspection report & certificate, please contact us at telephone: (86-755) 8307 1443, or email: CN.Doccheck@sgs.com  
 No.1 Workshop, M-10, Middle Section, Science & Technology Park, Nanshan District, Shenzhen, Guangdong, China 518057 t (86-755) 26012053 f (86-755) 26710594 www.sgs.com.cn  
 中国·广东·深圳市南山区科技园中区M-10栋1号厂房 邮编: 518057 t (86-755) 26012053 f (86-755) 26710594 sgs.china@sgs.com



Polarity: Horizontal; Modulation:802.11ax(Full RU0); Bandwidth:40MHz; Channel:Low

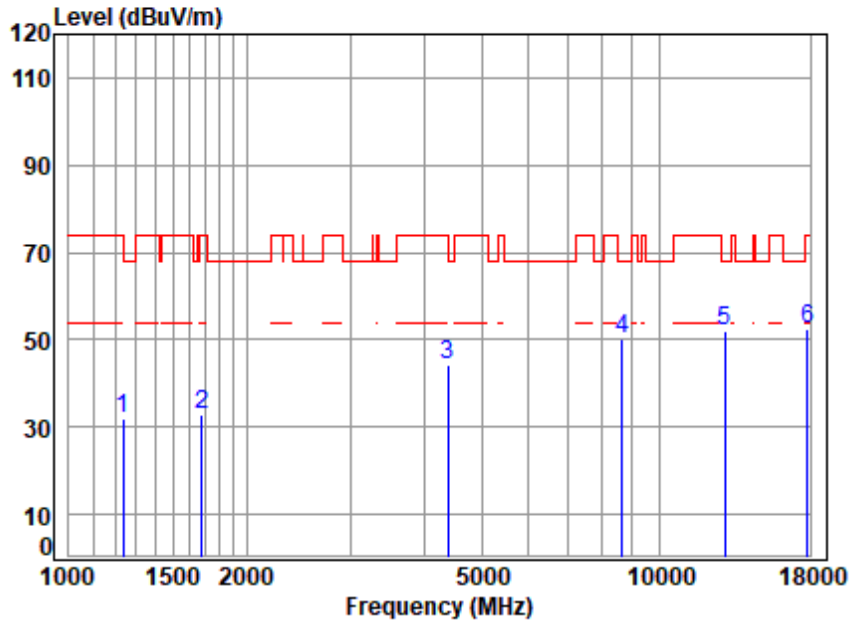

Site : chamber  
 Condition: 3m HORIZONTAL  
 Job No : 00384AT/00385AT  
 Mode : 6445 TX RSE  
 Note : 6E WIFI 11AX40

	Freq	Cable Loss	Ant Factor	Preamp Factor	Read Level	Limit Level	Over Limit	Remark
	MHz	dB	dB/m	dB	dBuV	dBuV/m	dBuV/m	dB
1	1234.909	3.64	24.89	38.35	41.54	74.00	-42.28	peak
2	1682.477	4.31	26.24	38.41	40.87	74.00	-40.99	peak
3	4379.699	7.04	34.64	35.81	38.36	74.00	-29.77	peak
4	8663.404	11.33	36.90	37.27	39.38	68.20	-17.86	peak
5	12890.000	13.50	38.19	37.30	37.51	68.20	-16.30	peak
6	17793.090	15.03	43.89	37.63	31.26	74.00	-21.45	peak



Unless otherwise agreed in writing, this document is issued by the Company subject to its General Conditions of Service printed overleaf, available on request or accessible at <https://www.sgs.com/en/Terms-and-Conditions>. Attention is drawn to the limitation of liability, indemnification and jurisdiction issues defined therein. Any holder of this document is advised that information contained hereon reflects the Company's findings at the time of its intervention only and within the limits of Client's instructions, if any. The Company's sole responsibility is to its Client and this document does not exonerate parties to a transaction from exercising all their rights and obligations under the transaction documents. This document cannot be reproduced except in full, without prior written approval of the Company. Any unauthorized alteration, forgery or falsification of the content or appearance of this document is unlawful and offenders may be prosecuted to the fullest extent of the law. Unless otherwise stated the results shown in this test report refer only to the sample(s) tested and such sample(s) are retained for 30 days only.

Attention: To check the authenticity of testing /inspection report & certificate, please contact us at telephone: (86-755) 8307 1443, or email: CN.Doccheck@sgs.com

No.1 Workshop, M-10, Middle Section, Science & Technology Park, Nanshan District, Shenzhen, Guangdong, China 518057 t (86-755) 26012053 f (86-755) 26710594 www.sgs.com.cn  
 中国·广东·深圳市南山区科技园中区M-10栋1号厂房 邮编: 518057 t (86-755) 26012053 f (86-755) 26710594 sgs.china@sgs.com

Polarity: Vertical; Modulation:802.11ax(Full RU0); Bandwidth:40MHz; Channel:Low

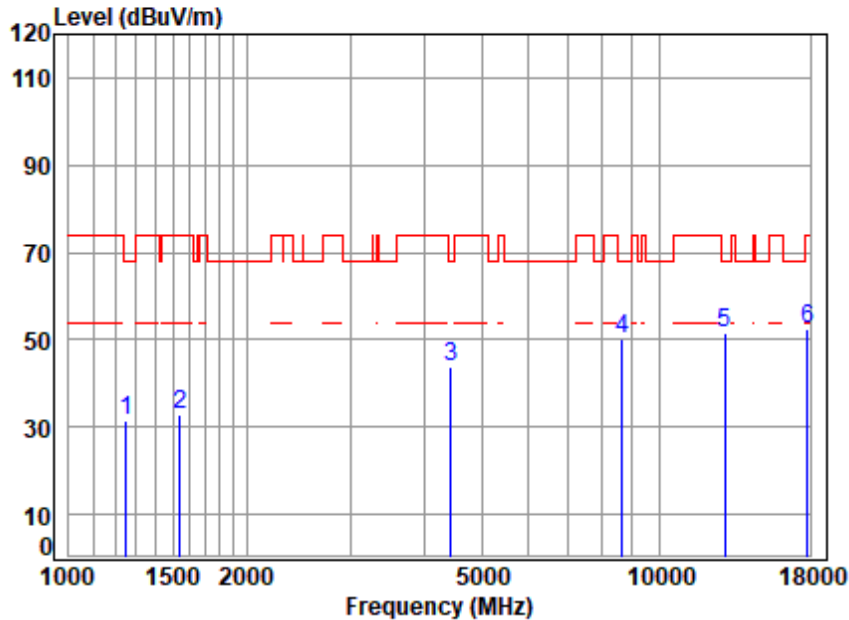

Site : chamber  
 Condition: 3m VERTICAL  
 Job No : 00384AT/00385AT  
 Mode : 6445 TX RSE  
 Note : 6E WIFI 11AX40

	Freq	Cable Loss	Ant Factor	Preamp Factor	Read Level	Limit Level	Over Line	Over Limit	Remark
	MHz	dB	dB/m	dB	dBuV	dBuV/m	dBuV/m	dB	
1	1252.885	3.67	25.08	38.35	40.96	31.36	68.20	-36.84	peak
2	1542.733	4.12	26.97	38.39	40.11	32.81	74.00	-41.19	peak
3	4443.453	7.09	34.28	35.77	37.98	43.58	68.20	-24.62	peak
4	8638.399	11.29	36.90	37.24	39.05	50.00	68.20	-18.20	peak
5	12890.000	13.50	38.19	37.30	37.30	51.69	68.20	-16.51	peak
6	17793.090	15.03	43.89	37.63	31.31	52.60	74.00	-21.40	peak



Unless otherwise agreed in writing, this document is issued by the Company subject to its General Conditions of Service printed overleaf, available on request or accessible at <https://www.sgs.com/en/Terms-and-Conditions>. Attention is drawn to the limitation of liability, indemnification and jurisdiction issues defined therein. Any holder of this document is advised that information contained hereon reflects the Company's findings at the time of its intervention only and within the limits of Client's instructions, if any. The Company's sole responsibility is to its Client and this document does not exonerate parties to a transaction from exercising all their rights and obligations under the transaction documents. This document cannot be reproduced except in full, without prior written approval of the Company. Any unauthorized alteration, forgery or falsification of the content or appearance of this document is unlawful and offenders may be prosecuted to the fullest extent of the law. Unless otherwise stated the results shown in this test report refer only to the sample(s) tested and such sample(s) are retained for 30 days only.

Attention: To check the authenticity of testing /inspection report & certificate, please contact us at telephone: (86-755) 8307 1443, or email: CN.Doccheck@sgs.com  
 No.1 Workshop, M-10, Middle Section, Science & Technology Park, Nanshan District, Shenzhen, Guangdong, China 518057 t (86-755) 26012053 f (86-755) 26710594 www.sgs.com.cn  
 中国·广东·深圳市南山区科技园中区M-10栋1号厂房 邮编: 518057 t (86-755) 26012053 f (86-755) 26710594 sgs.china@sgs.com

Polarity: Horizontal; Modulation:802.11ax(Full RU0); Bandwidth:40MHz; Channel:High

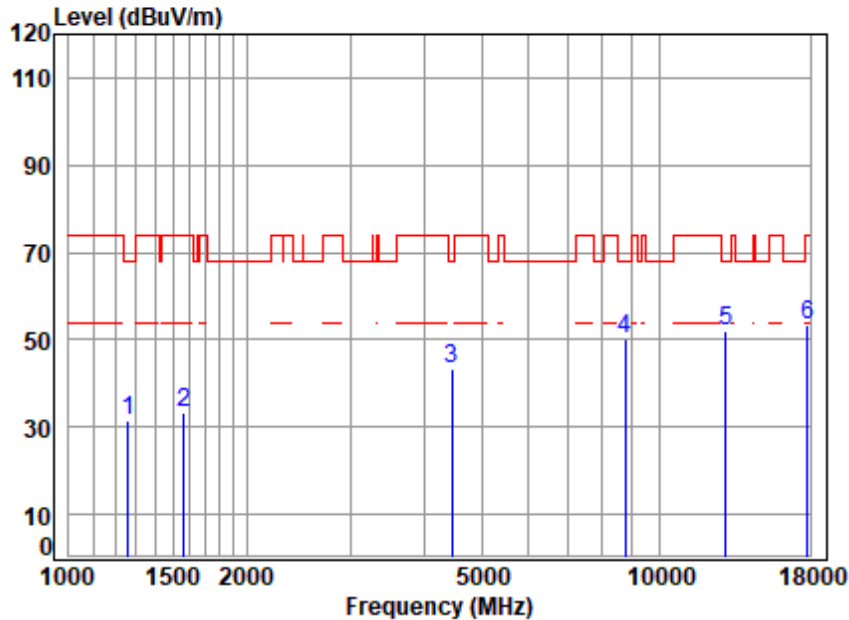

Site : chamber  
 Condition: 3m HORIZONTAL  
 Job No : 00384AT/00385AT  
 Mode : 6485 TX RSE  
 Note : 6E WIFI 11AX40

	Freq	Cable Loss	Ant Factor	Preamp Factor	Read Level	Limit Level	Over Line	Over Limit	Remark
	MHz	dB	dB/m	dB	dBuV	dBuV/m	dBuV/m	dB	
1	1260.149	3.69	25.04	38.35	41.22	31.60	68.20	-36.60	peak
2	1565.191	4.15	26.94	38.40	40.47	33.16	74.00	-40.84	peak
3	4456.315	7.09	34.12	35.76	37.89	43.34	68.20	-24.86	peak
4	8738.852	11.47	36.90	37.35	39.03	50.05	68.20	-18.15	peak
5	12970.000	13.54	38.13	37.28	37.68	52.07	68.20	-16.13	peak
6	17793.090	15.03	43.89	37.63	31.94	53.23	74.00	-20.77	peak



Unless otherwise agreed in writing, this document is issued by the Company subject to its General Conditions of Service printed overleaf, available on request or accessible at <https://www.sgs.com/en/Terms-and-Conditions>. Attention is drawn to the limitation of liability, indemnification and jurisdiction issues defined therein. Any holder of this document is advised that information contained hereon reflects the Company's findings at the time of its intervention only and within the limits of Client's instructions, if any. The Company's sole responsibility is to its Client and this document does not exonerate parties to a transaction from exercising all their rights and obligations under the transaction documents. This document cannot be reproduced except in full, without prior written approval of the Company. Any unauthorized alteration, forgery or falsification of the content or appearance of this document is unlawful and offenders may be prosecuted to the fullest extent of the law. Unless otherwise stated the results shown in this test report refer only to the sample(s) tested and such sample(s) are retained for 30 days only.  
 Attention: To check the authenticity of testing /inspection report & certificate, please contact us at telephone: (86-755) 8307 1443, or email: CN.Doccheck@sgs.com  
 No.1 Workshop, M-10, Middle Section, Science & Technology Park, Nanshan District, Shenzhen, Guangdong, China 518057 t (86-755) 26012053 f (86-755) 26710594 www.sgs.com.cn  
 中国·广东·深圳市南山区科技园中区M-10栋1号厂房 邮编: 518057 t (86-755) 26012053 f (86-755) 26710594 sgs.china@sgs.com



Polarity: Vertical; Modulation:802.11ax(Full RU0); Bandwidth:40MHz; Channel:High

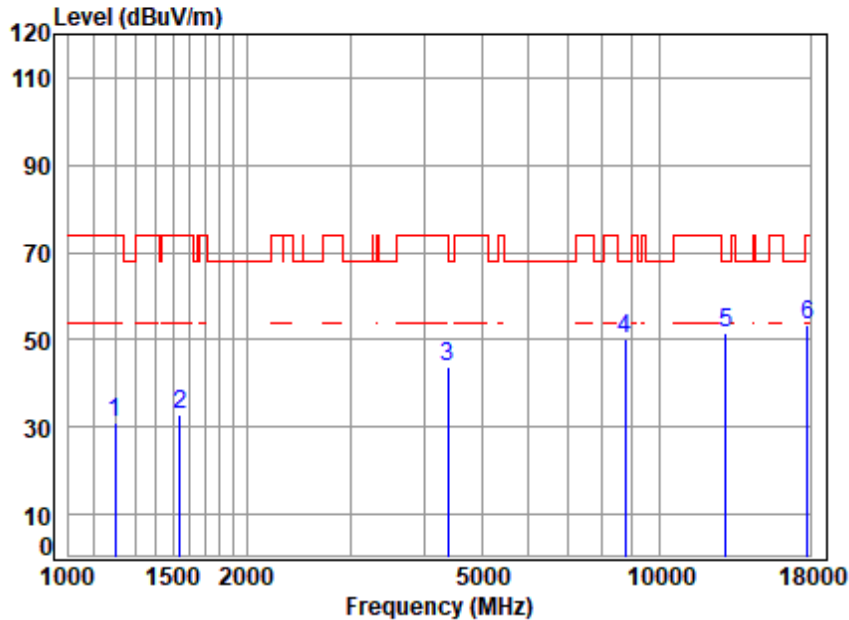

Site : chamber  
 Condition: 3m VERTICAL  
 Job No : 00384AT/00385AT  
 Mode : 6485 TX RSE  
 Note : 6E WIFI 11AX40

	Freq	Cable Loss	Ant Factor	Preamp Factor	Read Level	Limit Level	Over Limit	Remark
	MHz	dB	dB/m	dB	dBuV	dBuV/m	dBuV/m	dB
1	1199.726	3.58	24.40	38.34	41.43	31.07	74.00	-42.93 peak
2	1542.733	4.12	26.97	38.39	40.04	32.74	74.00	-41.26 peak
3	4392.376	7.05	34.74	35.80	37.93	43.92	74.00	-30.08 peak
4	8764.146	11.51	36.96	37.37	39.21	50.31	68.20	-17.89 peak
5	12970.000	13.54	38.13	37.28	37.08	51.47	68.20	-16.73 peak
6	17793.090	15.03	43.89	37.63	31.93	53.22	74.00	-20.78 peak



Unless otherwise agreed in writing, this document is issued by the Company subject to its General Conditions of Service printed overleaf, available on request or accessible at <https://www.sgs.com/en/Terms-and-Conditions>. Attention is drawn to the limitation of liability, indemnification and jurisdiction issues defined therein. Any holder of this document is advised that information contained hereon reflects the Company's findings at the time of its intervention only and within the limits of Client's instructions, if any. The Company's sole responsibility is to its Client and this document does not exonerate parties to a transaction from exercising all their rights and obligations under the transaction documents. This document cannot be reproduced except in full, without prior written approval of the Company. Any unauthorized alteration, forgery or falsification of the content or appearance of this document is unlawful and offenders may be prosecuted to the fullest extent of the law. Unless otherwise stated the results shown in this test report refer only to the sample(s) tested and such sample(s) are retained for 30 days only.

Attention: To check the authenticity of testing /inspection report & certificate, please contact us at telephone: (86-755) 8307 1443, or email: CN.Doccheck@sgs.com  
 No.1 Workshop, M-10, Middle Section, Science & Technology Park, Nanshan District, Shenzhen, Guangdong, China 518057 t (86-755) 26012053 f (86-755) 26710594 www.sgsgroup.com.cn  
 中国·广东·深圳市南山区科技园中区M-10栋1号厂房 邮编: 518057 t (86-755) 26012053 f (86-755) 26710594 sgs.china@sgs.com

Polarity: Horizontal; Modulation:802.11ax(Full RU0); Bandwidth:80MHz; Channel:middle

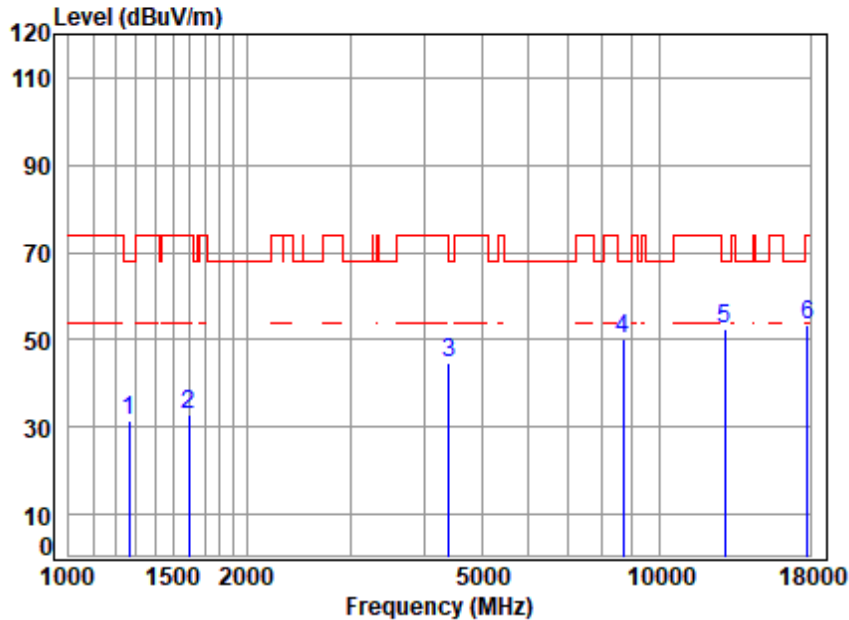

Site : chamber  
 Condition: 3m HORIZONTAL  
 Job No : 00384AT/00385AT  
 Mode : 6465 TX RSE  
 Note : 6E WIFI 11AX80

	Freq	Cable Loss	Ant Factor	Preamp Factor	Read Level	Limit Level	Over Limit	Remark
	MHz	dB	dB/m	dB	dBuV	dBuV/m	dBuV/m	dB
1	1267.454	3.70	25.00	38.35	41.02	31.37	68.20	-36.83 peak
2	1597.181	4.20	26.81	38.40	40.36	32.97	74.00	-41.03 peak
3	4405.090	7.06	34.74	35.79	38.50	44.51	68.20	-23.69 peak
4	8688.480	11.38	36.90	37.30	39.23	50.21	68.20	-17.99 peak
5	12930.000	13.52	38.17	37.29	37.98	52.38	68.20	-15.82 peak
6	17793.090	15.03	43.89	37.63	32.10	53.39	74.00	-20.61 peak



Unless otherwise agreed in writing, this document is issued by the Company subject to its General Conditions of Service printed overleaf, available on request or accessible at <https://www.sgs.com/en/Terms-and-Conditions>. Attention is drawn to the limitation of liability, indemnification and jurisdiction issues defined therein. Any holder of this document is advised that information contained hereon reflects the Company's findings at the time of its intervention only and within the limits of Client's instructions, if any. The Company's sole responsibility is to its Client and this document does not exonerate parties to a transaction from exercising all their rights and obligations under the transaction documents. This document cannot be reproduced except in full, without prior written approval of the Company. Any unauthorized alteration, forgery or falsification of the content or appearance of this document is unlawful and offenders may be prosecuted to the fullest extent of the law. Unless otherwise stated the results shown in this test report refer only to the sample(s) tested and such sample(s) are retained for 30 days only.

Attention: To check the authenticity of testing /inspection report & certificate, please contact us at telephone: (86-755) 8307 1443, or email: CN.Doccheck@sgs.com  
 No.1 Workshop, M-10, Middle Section, Science & Technology Park, Nanshan District, Shenzhen, Guangdong, China 518057 t (86-755) 26012053 f (86-755) 26710594 www.sgs.com.cn  
 中国·广东·深圳市南山区科技园中区M-10栋1号厂房 邮编: 518057 t (86-755) 26012053 f (86-755) 26710594 sgs.china@sgs.com

Polarity: Vertical; Modulation:802.11ax(Full RU0); Bandwidth:80MHz; Channel:middle

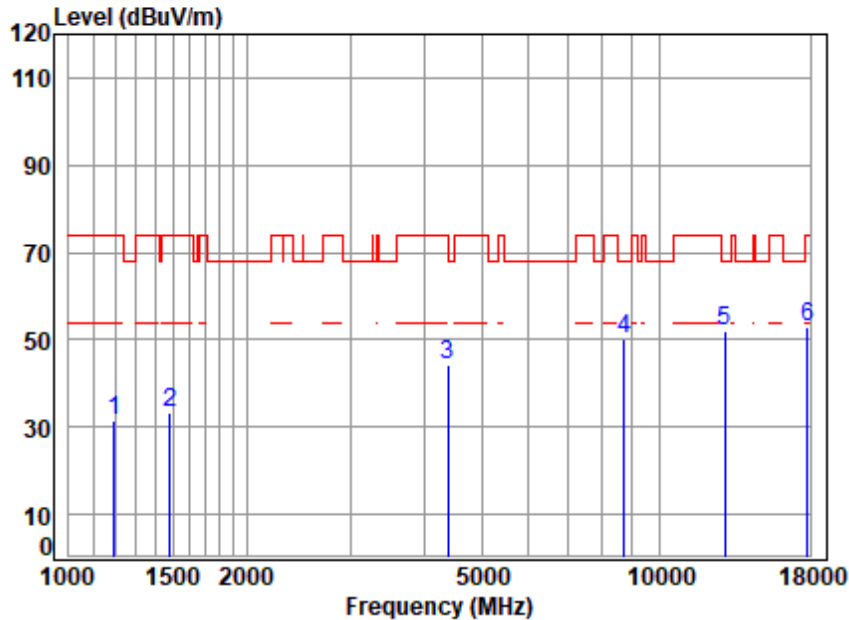

Site : chamber  
 Condition: 3m VERTICAL  
 Job No : 00384AT/00385AT  
 Mode : 6465 TX RSE  
 Note : 6E WIFI 11AX80

	Freq	Cable Loss	Ant Factor	Preamp Factor	Read Level	Limit Level	Over Limit	Remark
	MHz	dB	dB/m	dB	dBuV	dBuV/m	dBuV/m	dB
1	1192.811	3.57	24.33	38.34	42.02	74.00	-42.42	peak
2	1485.841	4.04	26.40	38.39	41.06	74.00	-40.89	peak
3	4392.376	7.05	34.74	35.80	38.07	74.00	-29.94	peak
4	8713.630	11.42	36.90	37.32	39.42	68.20	-17.78	peak
5	12930.000	13.52	38.17	37.29	37.72	68.20	-16.08	peak
6	17793.090	15.03	43.89	37.63	31.41	74.00	-21.30	peak



Unless otherwise agreed in writing, this document is issued by the Company subject to its General Conditions of Service printed overleaf, available on request or accessible at <https://www.sgs.com/en/Terms-and-Conditions>. Attention is drawn to the limitation of liability, indemnification and jurisdiction issues defined therein. Any holder of this document is advised that information contained hereon reflects the Company's findings at the time of its intervention only and within the limits of Client's instructions, if any. The Company's sole responsibility is to its Client and this document does not exonerate parties to a transaction from exercising all their rights and obligations under the transaction documents. This document cannot be reproduced except in full, without prior written approval of the Company. Any unauthorized alteration, forgery or falsification of the content or appearance of this document is unlawful and offenders may be prosecuted to the fullest extent of the law. Unless otherwise stated the results shown in this test report refer only to the sample(s) tested and such sample(s) are retained for 30 days only.

Attention: To check the authenticity of testing /inspection report & certificate, please contact us at telephone: (86-755) 8307 1443, or email: CN.Doccheck@sgs.com  
 No.1 Workshop, M-10, Middle Section, Science & Technology Park, Nanshan District, Shenzhen, Guangdong, China 518057 t (86-755) 26012053 f (86-755) 26710594 www.sgsgroup.com.cn  
 中国·广东·深圳市南山区科技园中区M-10栋1号厂房 邮编: 518057 t (86-755) 26012053 f (86-755) 26710594 sgs.china@sgs.com



Polarity: Horizontal; Modulation:802.11ax(Full RU0); Bandwidth:20MHz; Channel:Low

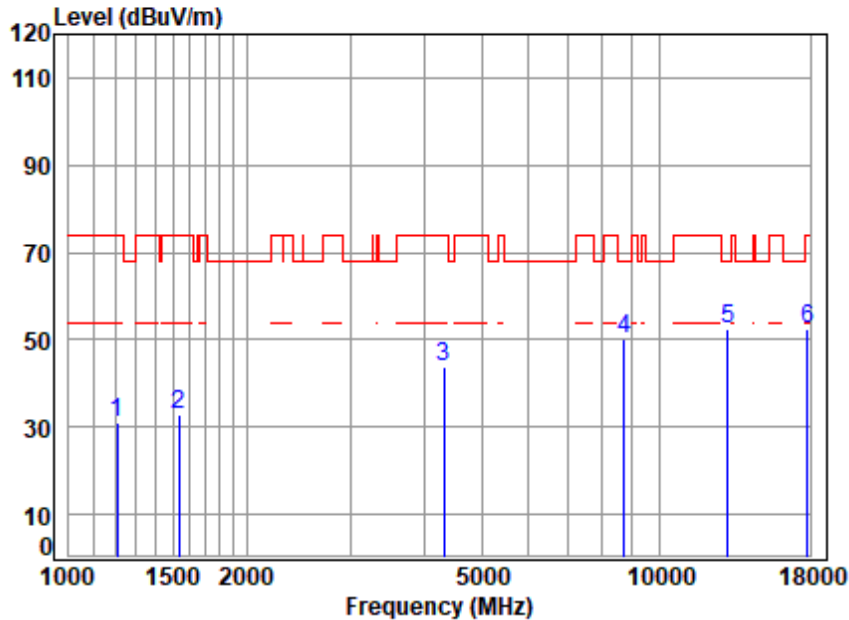

Site : chamber  
 Condition: 3m HORIZONTAL  
 Job No : 00384AT/00385AT  
 Mode : 6535 TX RSE  
 Note : 6E WIFI 11AX20

	Freq	Cable Loss	Ant Factor	Preamp Factor	Read Level	Limit Level	Over Limit	Remark
	MHz	dB	dB/m	dB	dBuV	dBuV/m	dBuV/m	dB
1	1206.682	3.59	24.49	38.34	41.50	74.00	-42.76	peak
2	1538.281	4.12	26.95	38.39	40.18	74.00	-41.14	peak
3	4316.859	7.00	34.13	35.86	38.49	74.00	-30.24	peak
4	8713.630	11.42	36.90	37.32	39.06	68.20	-18.14	peak
5	13070.000	13.57	38.31	37.27	37.89	68.20	-15.70	peak
6	17793.090	15.03	43.89	37.63	31.18	74.00	-21.53	peak



Unless otherwise agreed in writing, this document is issued by the Company subject to its General Conditions of Service printed overleaf, available on request or accessible at <https://www.sgs.com/en/Terms-and-Conditions>. Attention is drawn to the limitation of liability, indemnification and jurisdiction issues defined therein. Any holder of this document is advised that information contained hereon reflects the Company's findings at the time of its intervention only and within the limits of Client's instructions, if any. The Company's sole responsibility is to its Client and this document does not exonerate parties to a transaction from exercising all their rights and obligations under the transaction documents. This document cannot be reproduced except in full, without prior written approval of the Company. Any unauthorized alteration, forgery or falsification of the content or appearance of this document is unlawful and offenders may be prosecuted to the fullest extent of the law. Unless otherwise stated the results shown in this test report refer only to the sample(s) tested and such sample(s) are retained for 30 days only.

Attention: To check the authenticity of testing /inspection report & certificate, please contact us at telephone: (86-755) 8307 1443, or email: CN.Doccheck@sgs.com  
 No.1 Workshop, M-10, Middle Section, Science & Technology Park, Nanshan District, Shenzhen, Guangdong, China 518057 t (86-755) 26012053 f (86-755) 26710594 www.sgsgroup.com.cn  
 中国·广东·深圳市南山区科技园中区M-10栋1号厂房 邮编: 518057 t (86-755) 26012053 f (86-755) 26710594 sgs.china@sgs.com

Polarity: Vertical; Modulation:802.11ax(Full RU0); Bandwidth:20MHz; Channel:Low

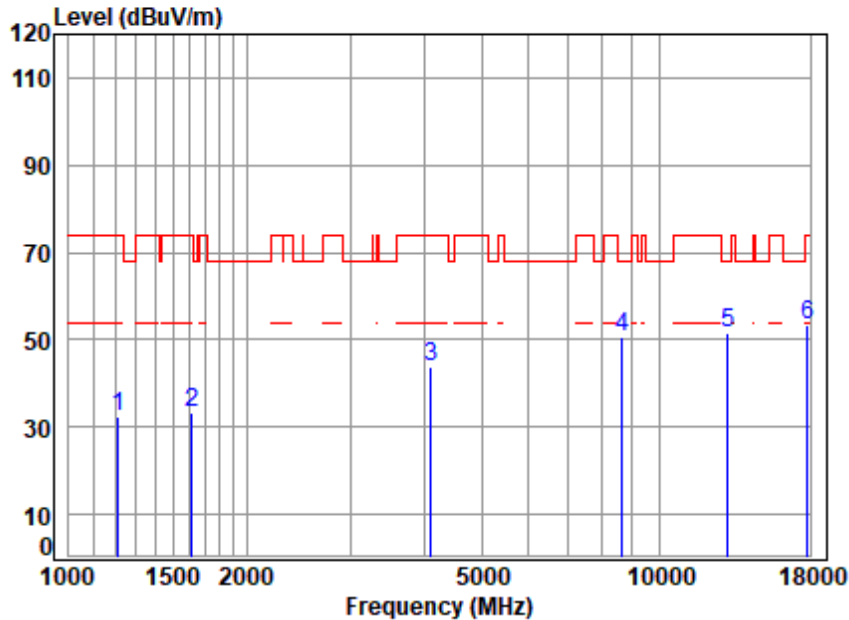

Site : chamber  
 Condition: 3m VERTICAL  
 Job No : 00384AT/00385AT  
 Mode : 6535 TX RSE  
 Note : 6E WIFI 11AX20

	Freq	Cable Loss	Ant Factor	Preamp Factor	Read Level	Limit Level	Over Limit	Remark
	MHz	dB	dB/m	dB	dBuV	dBuV/m	dBuV/m	dB
1	1210.174	3.60	24.54	38.34	42.72	32.52	74.00	-41.48 peak
2	1615.754	4.22	26.64	38.40	40.90	33.36	74.00	-40.64 peak
3	4109.872	6.86	33.16	36.01	39.81	43.82	74.00	-30.18 peak
4	8663.404	11.33	36.90	37.27	39.56	50.52	68.20	-17.68 peak
5	13070.000	13.57	38.31	37.27	36.99	51.60	68.20	-16.60 peak
6	17793.090	15.03	43.89	37.63	31.96	53.25	74.00	-20.75 peak



Unless otherwise agreed in writing, this document is issued by the Company subject to its General Conditions of Service printed overleaf, available on request or accessible at <https://www.sgs.com/en/Terms-and-Conditions>. Attention is drawn to the limitation of liability, indemnification and jurisdiction issues defined therein. Any holder of this document is advised that information contained hereon reflects the Company's findings at the time of its intervention only and within the limits of Client's instructions, if any. The Company's sole responsibility is to its Client and this document does not exonerate parties to a transaction from exercising all their rights and obligations under the transaction documents. This document cannot be reproduced except in full, without prior written approval of the Company. Any unauthorized alteration, forgery or falsification of the content or appearance of this document is unlawful and offenders may be prosecuted to the fullest extent of the law. Unless otherwise stated the results shown in this test report refer only to the sample(s) tested and such sample(s) are retained for 30 days only.

Attention: To check the authenticity of testing /inspection report & certificate, please contact us at telephone: (86-755) 8307 1443, or email: CN.Doccheck@sgs.com  
 No.1 Workshop, M-10, Middle Section, Science & Technology Park, Nanshan District, Shenzhen, Guangdong, China 518057 t (86-755) 26012053 f (86-755) 26710594 www.sgs.com.cn  
 中国·广东·深圳市南山区科技园中区M-10栋1号厂房 邮编: 518057 t (86-755) 26012053 f (86-755) 26710594 sgs.china@sgs.com

Polarity: Horizontal; Modulation:802.11ax(Full RU0); Bandwidth:20MHz; Channel:middle

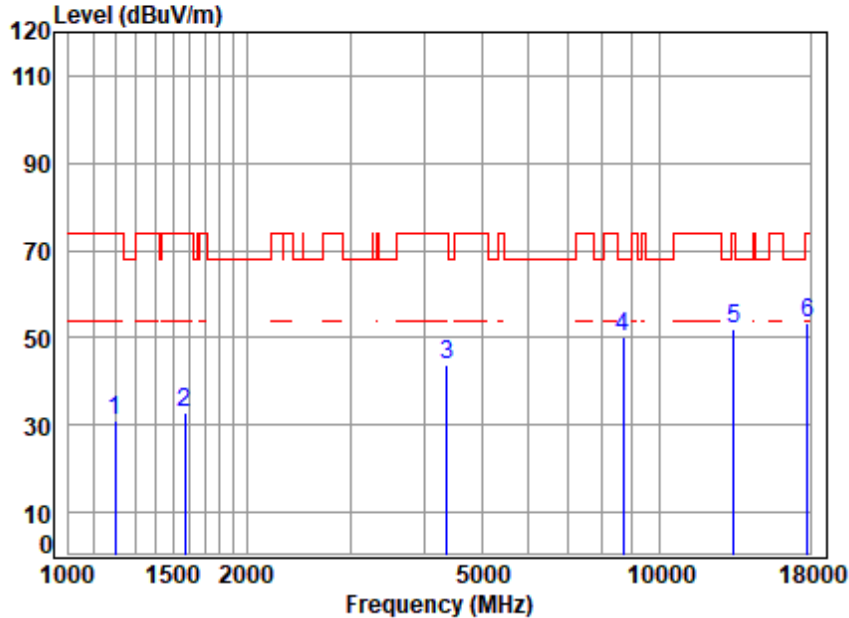

Site : chamber  
 Condition: 3m HORIZONTAL  
 Job No : 00384AT/00385AT  
 Mode : 6695 TX RSE  
 Note : 6E WIFI 11AX20

	Freq	Cable Loss	Ant Factor	Preamp Factor	Read Level	Limit Level	Over Line	Over Limit	Remark
	MHz	dB	dB/m	dB	dBuV	dBuV/m	dBuV/m	dB	
1	1196.264	3.58	24.36	38.34	41.41	31.01	74.00	-42.99	peak
2	1574.265	4.17	26.90	38.40	40.04	32.71	74.00	-41.29	peak
3	4367.058	7.04	34.54	35.82	38.02	43.78	74.00	-30.22	peak
4 p	8688.480	11.38	36.90	37.30	39.28	50.26	68.20	-17.94	peak
5	13390.000	13.65	38.78	37.25	36.88	52.06	74.00	-21.94	peak
6	17793.090	15.03	43.89	37.63	32.03	53.32	74.00	-20.68	peak



Unless otherwise agreed in writing, this document is issued by the Company subject to its General Conditions of Service printed overleaf, available on request or accessible at <https://www.sgs.com/en/Terms-and-Conditions>. Attention is drawn to the limitation of liability, indemnification and jurisdiction issues defined therein. Any holder of this document is advised that information contained hereon reflects the Company's findings at the time of its intervention only and within the limits of Client's instructions, if any. The Company's sole responsibility is to its Client and this document does not exonerate parties to a transaction from exercising all their rights and obligations under the transaction documents. This document cannot be reproduced except in full, without prior written approval of the Company. Any unauthorized alteration, forgery or falsification of the content or appearance of this document is unlawful and offenders may be prosecuted to the fullest extent of the law. Unless otherwise stated the results shown in this test report refer only to the sample(s) tested and such sample(s) are retained for 30 days only.

Attention: To check the authenticity of testing /inspection report & certificate, please contact us at telephone: (86-755) 8307 1443, or email: CN.Doccheck@sgs.com

No.1 Workshop, M-10, Middle Section, Science & Technology Park, Nanshan District, Shenzhen, Guangdong, China 518057 t (86-755) 26012053 f (86-755) 26710594 www.sgsgroup.com.cn  
 中国·广东·深圳市南山区科技园中区M-10栋1号厂房 邮编: 518057 t (86-755) 26012053 f (86-755) 26710594 sgs.china@sgs.com



Polarity: Vertical; Modulation:802.11ax(Full RU0); Bandwidth:20MHz; Channel:middle

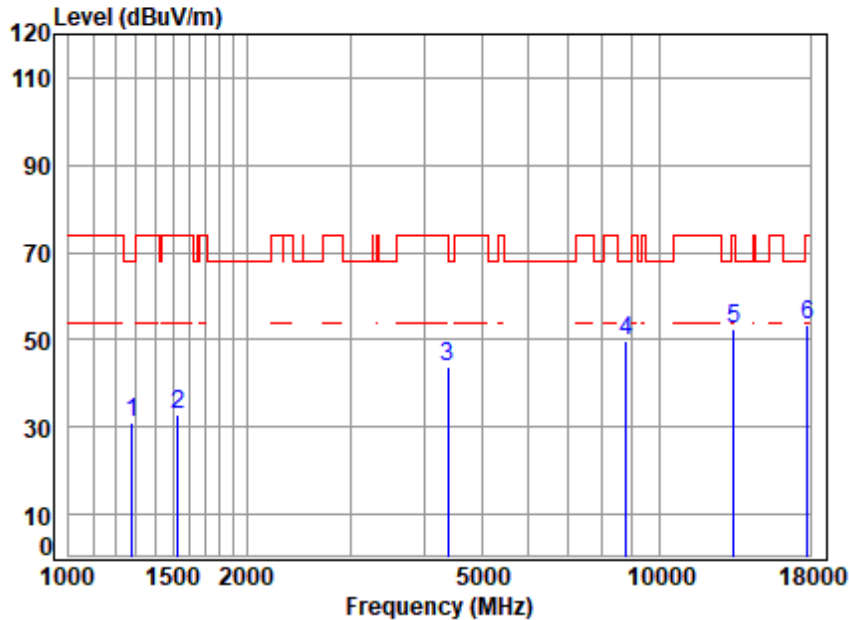

Site : chamber  
 Condition: 3m VERTICAL  
 Job No : 00384AT/00385AT  
 Mode : 6695 TX RSE  
 Note : 6E WIFI 11AX20

	Freq	Cable Loss	Ant Factor	Preamp Factor	Read Level	Limit Level	Over Limit	Remark
	MHz	dB	dB/m	dB	dBuV	dBuV/m	dBuV/m	dB
1	1278.492	3.72	24.93	38.35	40.79	31.09	68.20	-37.11 peak
2	1529.414	4.10	26.92	38.39	40.21	32.84	74.00	-41.16 peak
3	4392.376	7.05	34.74	35.80	37.81	43.80	74.00	-30.20 peak
4 p	8789.516	11.55	37.06	37.40	38.68	49.89	68.20	-18.31 peak
5	13390.000	13.65	38.78	37.25	37.37	52.55	74.00	-21.45 peak
6	17844.590	15.06	43.90	37.64	31.88	53.20	74.00	-20.80 peak



Unless otherwise agreed in writing, this document is issued by the Company subject to its General Conditions of Service printed overleaf, available on request or accessible at <https://www.sgs.com/en/Terms-and-Conditions>. Attention is drawn to the limitation of liability, indemnification and jurisdiction issues defined therein. Any holder of this document is advised that information contained hereon reflects the Company's findings at the time of its intervention only and within the limits of Client's instructions, if any. The Company's sole responsibility is to its Client and this document does not exonerate parties to a transaction from exercising all their rights and obligations under the transaction documents. This document cannot be reproduced except in full, without prior written approval of the Company. Any unauthorized alteration, forgery or falsification of the content or appearance of this document is unlawful and offenders may be prosecuted to the fullest extent of the law. Unless otherwise stated the results shown in this test report refer only to the sample(s) tested and such sample(s) are retained for 30 days only.

Attention: To check the authenticity of testing /inspection report & certificate, please contact us at telephone: (86-755) 8307 1443, or email: CN.Doccheck@sgs.com  
 No.1 Workshop, M-10, Middle Section, Science & Technology Park, Nanshan District, Shenzhen, Guangdong, China 518057 t (86-755) 26012053 f (86-755) 26710594 www.sgs.com.cn  
 中国·广东·深圳市南山区科技园中区M-10栋1号厂房 邮编: 518057 t (86-755) 26012053 f (86-755) 26710594 sgs.china@sgs.com

Polarity: Horizontal; Modulation:802.11ax(Full RU0); Bandwidth:20MHz; Channel:High

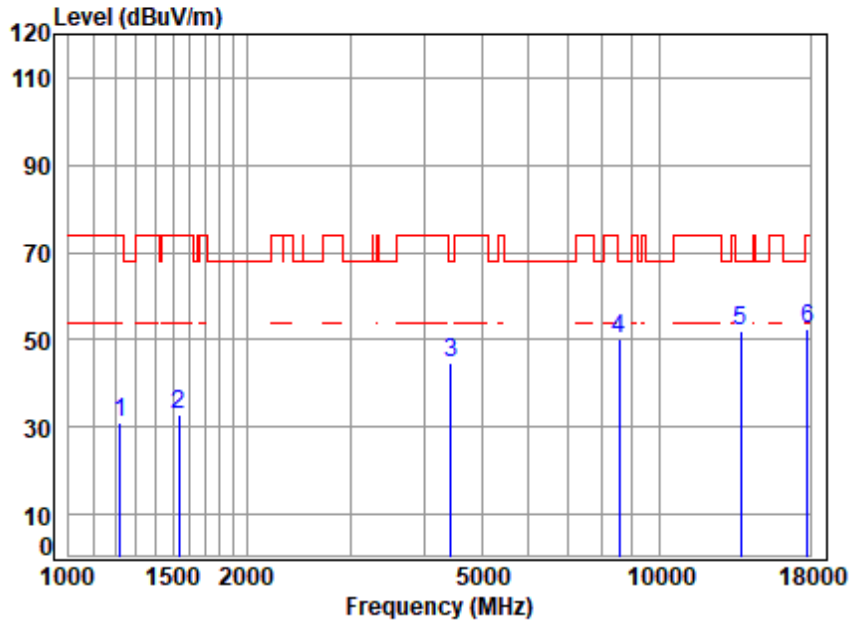

Site : chamber  
 Condition: 3m HORIZONTAL  
 Job No : 00384AT/00385AT  
 Mode : 6855 TX RSE  
 Note : 6E WIFI 11AX20

	Freq	Cable Loss	Ant Factor	Preamp Factor	Read Level	Limit Level	Over Limit	Remark
	MHz	dB	dB/m	dB	dBuV	dBuV/m	dBuV/m	dB
1	1220.714	3.62	24.69	38.34	41.16	31.13	74.00	-42.87 peak
2	1533.841	4.11	26.94	38.39	40.25	32.91	74.00	-41.09 peak
3	4443.453	7.09	34.28	35.77	38.94	44.54	68.20	-23.66 peak
4	8539.102	11.11	36.78	37.14	39.52	50.27	68.20	-17.93 peak
5	13710.000	13.72	39.12	37.23	36.25	51.86	68.20	-16.34 peak
6	17793.090	15.03	43.89	37.63	31.27	52.56	74.00	-21.44 peak



Unless otherwise agreed in writing, this document is issued by the Company subject to its General Conditions of Service printed overleaf, available on request or accessible at <https://www.sgs.com/en/Terms-and-Conditions>. Attention is drawn to the limitation of liability, indemnification and jurisdiction issues defined therein. Any holder of this document is advised that information contained hereon reflects the Company's findings at the time of its intervention only and within the limits of Client's instructions, if any. The Company's sole responsibility is to its Client and this document does not exonerate parties to a transaction from exercising all their rights and obligations under the transaction documents. This document cannot be reproduced except in full, without prior written approval of the Company. Any unauthorized alteration, forgery or falsification of the content or appearance of this document is unlawful and offenders may be prosecuted to the fullest extent of the law. Unless otherwise stated the results shown in this test report refer only to the sample(s) tested and such sample(s) are retained for 30 days only.

Attention: To check the authenticity of testing /inspection report & certificate, please contact us at telephone: (86-755) 8307 1443, or email: CN.Doccheck@sgs.com

No.1 Workshop, M-10, Middle Section, Science & Technology Park, Nanshan District, Shenzhen, Guangdong, China 518057 t (86-755) 26012053 f (86-755) 26710594 www.sgs.com.cn  
 中国·广东·深圳市南山区科技园中区M-10栋1号厂房 邮编: 518057 t (86-755) 26012053 f (86-755) 26710594 sgs.china@sgs.com

Polarity: Vertical; Modulation:802.11ax(Full RU0); Bandwidth:20MHz; Channel:High

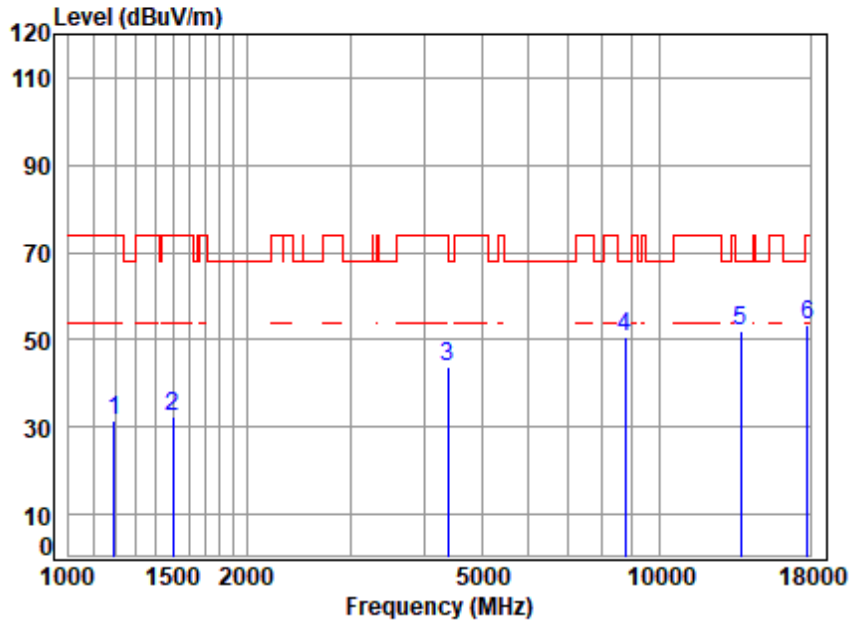

Site : chamber  
 Condition: 3m VERTICAL  
 Job No : 00384AT/00385AT  
 Mode : 6855 TX RSE  
 Note : 6E WIFI 11AX20

	Freq	Cable Loss	Ant Factor	Preamp Factor	Read Level	Limit Level	Over Limit	Remark
	MHz	dB	dB/m	dB	dBuV	dBuV/m	dBuV/m	dB
1	1192.811	3.57	24.33	38.34	41.81	74.00	-42.63	peak
2	1503.119	4.07	26.81	38.39	40.05	74.00	-41.46	peak
3	4379.699	7.04	34.64	35.81	37.87	74.00	-30.26	peak
4	8764.146	11.51	36.96	37.37	39.74	68.20	-17.36	peak
5	13710.000	13.72	39.12	37.23	36.48	68.20	-16.11	peak
6	17793.090	15.03	43.89	37.63	31.91	74.00	-20.80	peak



Unless otherwise agreed in writing, this document is issued by the Company subject to its General Conditions of Service printed overleaf, available on request or accessible at <https://www.sgs.com/en/Terms-and-Conditions>. Attention is drawn to the limitation of liability, indemnification and jurisdiction issues defined therein. Any holder of this document is advised that information contained hereon reflects the Company's findings at the time of its intervention only and within the limits of Client's instructions, if any. The Company's sole responsibility is to its Client and this document does not exonerate parties to a transaction from exercising all their rights and obligations under the transaction documents. This document cannot be reproduced except in full, without prior written approval of the Company. Any unauthorized alteration, forgery or falsification of the content or appearance of this document is unlawful and offenders may be prosecuted to the fullest extent of the law. Unless otherwise stated the results shown in this test report refer only to the sample(s) tested and such sample(s) are retained for 30 days only.

Attention: To check the authenticity of testing /inspection report & certificate, please contact us at telephone: (86-755) 8307 1443, or email: CN.Doccheck@sgs.com  
 No.1 Workshop, M-10, Middle Section, Science & Technology Park, Nanshan District, Shenzhen, Guangdong, China 518057 t (86-755) 26012053 f (86-755) 26710594 www.sgsgroup.com.cn  
 中国·广东·深圳市南山区科技园中区M-10栋1号厂房 邮编: 518057 t (86-755) 26012053 f (86-755) 26710594 sgs.china@sgs.com



Polarity: Horizontal; Modulation:802.11ax(Full RU0); Bandwidth:40MHz; Channel:Low

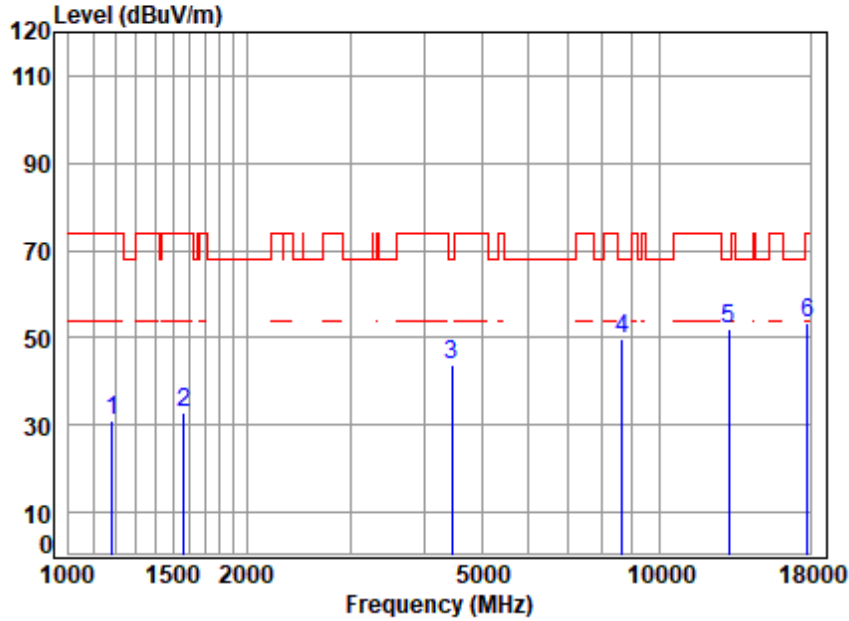

Site : chamber  
 Condition: 3m HORIZONTAL  
 Job No : 00384AT/00385AT  
 Mode : 6565 TX RSE  
 Note : 6E WIFI 11AX40

	Freq	Cable Loss	Ant Factor	Preamp Factor	Read Level	Limit Level	Over Line	Over Limit	Remark
	MHz	dB	dB/m	dB	dBuV	dBuV/m	dBuV/m	dB	
1	1185.936	3.56	24.26	38.34	41.56	31.04	74.00	-42.96	peak
2	1569.721	4.16	26.92	38.40	40.24	32.92	74.00	-41.08	peak
3	4456.315	7.09	34.12	35.76	38.47	43.92	68.20	-24.28	peak
4	8638.399	11.29	36.90	37.24	38.89	49.84	68.20	-18.36	peak
5	13130.000	13.58	38.46	37.26	37.10	51.88	68.20	-16.32	peak
6	17793.090	15.03	43.89	37.63	32.16	53.45	74.00	-20.55	peak



Unless otherwise agreed in writing, this document is issued by the Company subject to its General Conditions of Service printed overleaf, available on request or accessible at <https://www.sgs.com/en/Terms-and-Conditions>. Attention is drawn to the limitation of liability, indemnification and jurisdiction issues defined therein. Any holder of this document is advised that information contained hereon reflects the Company's findings at the time of its intervention only and within the limits of Client's instructions, if any. The Company's sole responsibility is to its Client and this document does not exonerate parties to a transaction from exercising all their rights and obligations under the transaction documents. This document cannot be reproduced except in full, without prior written approval of the Company. Any unauthorized alteration, forgery or falsification of the content or appearance of this document is unlawful and offenders may be prosecuted to the fullest extent of the law. Unless otherwise stated the results shown in this test report refer only to the sample(s) tested and such sample(s) are retained for 30 days only.

Attention: To check the authenticity of testing /inspection report & certificate, please contact us at telephone: (86-755) 8307 1443, or email: CN.Doccheck@sgs.com  
 No.1 Workshop, M-10, Middle Section, Science & Technology Park, Nanshan District, Shenzhen, Guangdong, China 518057 t (86-755) 26012053 f (86-755) 26710594 www.sgs.com.cn  
 中国·广东·深圳市南山区科技园中区M-10栋1号厂房 邮编: 518057 t (86-755) 26012053 f (86-755) 26710594 sgs.china@sgs.com

Polarity: Vertical; Modulation:802.11ax(Full RU0); Bandwidth:40MHz; Channel:Low

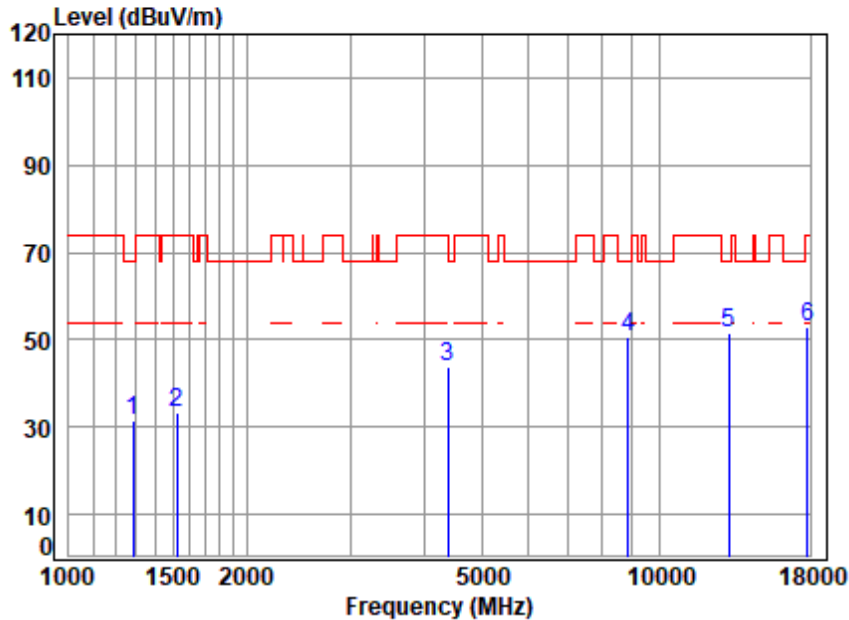

Site : chamber  
 Condition: 3m VERTICAL  
 Job No : 00384AT/00385AT  
 Mode : 6565 TX RSE  
 Note : 6E WIFI 11AX40

	Freq	Cable Loss	Ant Factor	Preamp Factor	Read Level	Limit Level	Over Limit	Remark
	MHz	dB	dB/m	dB	dBuV	dBuV/m	dBuV/m	dB
1	1285.904	3.73	24.88	38.35	41.32	31.58	68.20	-36.62 peak
2	1525.000	4.10	26.90	38.39	40.49	33.10	74.00	-40.90 peak
3	4392.376	7.05	34.74	35.80	37.94	43.93	74.00	-30.07 peak
4	8866.062	11.69	37.20	37.48	39.03	50.44	68.20	-17.76 peak
5	13130.000	13.58	38.46	37.26	36.82	51.60	68.20	-16.60 peak
6	17844.590	15.06	43.90	37.64	31.79	53.11	74.00	-20.89 peak



Unless otherwise agreed in writing, this document is issued by the Company subject to its General Conditions of Service printed overleaf, available on request or accessible at <https://www.sgs.com/en/Terms-and-Conditions>. Attention is drawn to the limitation of liability, indemnification and jurisdiction issues defined therein. Any holder of this document is advised that information contained hereon reflects the Company's findings at the time of its intervention only and within the limits of Client's instructions, if any. The Company's sole responsibility is to its Client and this document does not exonerate parties to a transaction from exercising all their rights and obligations under the transaction documents. This document cannot be reproduced except in full, without prior written approval of the Company. Any unauthorized alteration, forgery or falsification of the content or appearance of this document is unlawful and offenders may be prosecuted to the fullest extent of the law. Unless otherwise stated the results shown in this test report refer only to the sample(s) tested and such sample(s) are retained for 30 days only.  
 Attention: To check the authenticity of testing /inspection report & certificate, please contact us at telephone: (86-755) 8307 1443, or email: CN.Doccheck@sgs.com  
 No.1 Workshop, M-10, Middle Section, Science & Technology Park, Nanshan District, Shenzhen, Guangdong, China 518057 t (86-755) 26012053 f (86-755) 26710594 www.sgs.com.cn  
 中国·广东·深圳市南山区科技园中区M-10栋1号厂房 邮编: 518057 t (86-755) 26012053 f (86-755) 26710594 sgs.china@sgs.com

Polarity: Horizontal; Modulation:802.11ax(Full RU0); Bandwidth:40MHz; Channel:middle

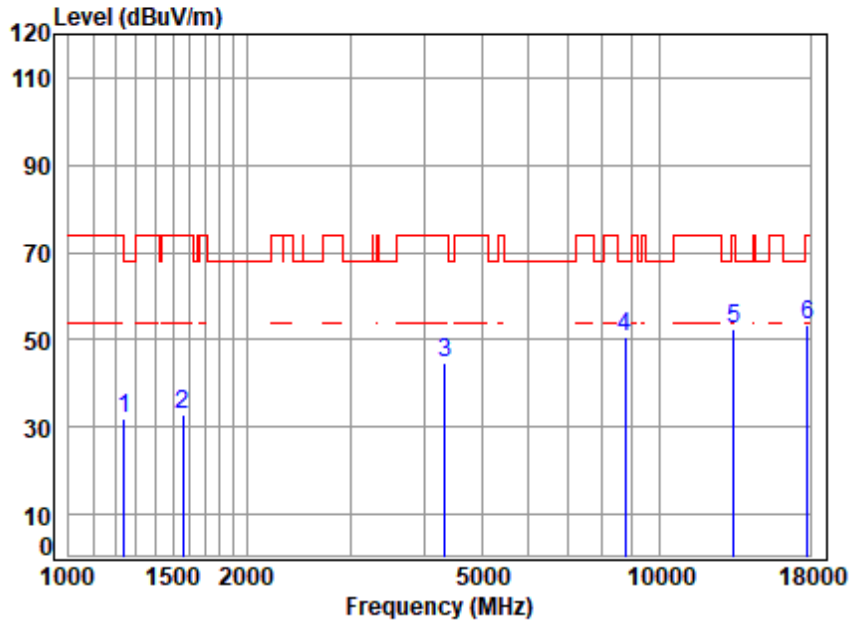

Site : chamber  
 Condition: 3m HORIZONTAL  
 Job No : 00384AT/00385AT  
 Mode : 6685 TX RSE  
 Note : 6E WIFI 11AX40

	Freq	Cable Loss	Ant Factor	Preamp Factor	Read Level	Limit Level	Over Line	Over Limit	Remark
	MHz	dB	dB/m	dB	dBuV	dBuV/m	dBuV/m	dB	
1	1242.068	3.66	24.99	38.35	41.61	31.91	68.20	-36.29	peak
2	1560.673	4.15	26.96	38.40	40.29	33.00	74.00	-41.00	peak
3	4341.886	7.02	34.34	35.84	38.98	44.50	74.00	-29.50	peak
4 p	8738.852	11.47	36.90	37.35	39.84	50.86	68.20	-17.34	peak
5	13370.000	13.64	38.74	37.25	37.29	52.42	74.00	-21.58	peak
6	17844.590	15.06	43.90	37.64	31.84	53.16	74.00	-20.84	peak



Unless otherwise agreed in writing, this document is issued by the Company subject to its General Conditions of Service printed overleaf, available on request or accessible at <https://www.sgs.com/en/Terms-and-Conditions>. Attention is drawn to the limitation of liability, indemnification and jurisdiction issues defined therein. Any holder of this document is advised that information contained hereon reflects the Company's findings at the time of its intervention only and within the limits of Client's instructions, if any. The Company's sole responsibility is to its Client and this document does not exonerate parties to a transaction from exercising all their rights and obligations under the transaction documents. This document cannot be reproduced except in full, without prior written approval of the Company. Any unauthorized alteration, forgery or falsification of the content or appearance of this document is unlawful and offenders may be prosecuted to the fullest extent of the law. Unless otherwise stated the results shown in this test report refer only to the sample(s) tested and such sample(s) are retained for 30 days only.

Attention: To check the authenticity of testing /inspection report & certificate, please contact us at telephone: (86-755) 8307 1443, or email: CN.Doccheck@sgs.com

No.1 Workshop, M-10, Middle Section, Science & Technology Park, Nanshan District, Shenzhen, Guangdong, China 518057 t (86-755) 26012053 f (86-755) 26710594 www.sgsgroup.com.cn  
 中国·广东·深圳市南山区科技园中区M-10栋1号厂房 邮编: 518057 t (86-755) 26012053 f (86-755) 26710594 sgs.china@sgs.com



Polarity: Vertical; Modulation:802.11ax(Full RU0); Bandwidth:40MHz; Channel:middle

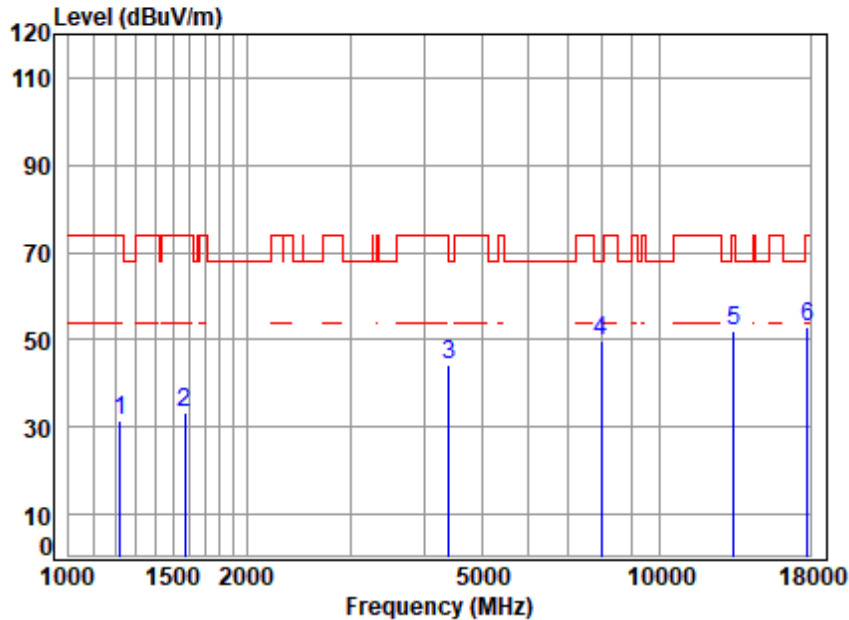

Site : chamber  
 Condition: 3m VERTICAL  
 Job No : 00384AT/00385AT  
 Mode : 6685 TX RSE  
 Note : 6E WIFI 11AX40

	Freq	Cable Loss	Ant Factor	Preamp Factor	Read Level	Limit Level	Over Limit	Remark
	MHz	dB	dB/m	dB	dBuV	dBuV/m	dBuV/m	dB
1	1224.247	3.62	24.74	38.34	41.29	74.00	-42.69	peak
2	1574.265	4.17	26.90	38.40	40.59	74.00	-40.74	peak
3	4405.090	7.06	34.74	35.79	38.32	68.20	-23.87	peak
4 p	7966.832	10.06	36.40	36.53	39.74	68.20	-18.53	peak
5	13370.000	13.64	38.74	37.25	36.76	74.00	-22.11	peak
6	17844.590	15.06	43.90	37.64	31.78	74.00	-20.90	peak



Unless otherwise agreed in writing, this document is issued by the Company subject to its General Conditions of Service printed overleaf, available on request or accessible at <https://www.sgs.com/en/Terms-and-Conditions>. Attention is drawn to the limitation of liability, indemnification and jurisdiction issues defined therein. Any holder of this document is advised that information contained hereon reflects the Company's findings at the time of its intervention only and within the limits of Client's instructions, if any. The Company's sole responsibility is to its Client and this document does not exonerate parties to a transaction from exercising all their rights and obligations under the transaction documents. This document cannot be reproduced except in full, without prior written approval of the Company. Any unauthorized alteration, forgery or falsification of the content or appearance of this document is unlawful and offenders may be prosecuted to the fullest extent of the law. Unless otherwise stated the results shown in this test report refer only to the sample(s) tested and such sample(s) are retained for 30 days only.

Attention: To check the authenticity of testing /inspection report & certificate, please contact us at telephone: (86-755) 8307 1443, or email: CN.Doccheck@sgs.com  
 No.1 Workshop, M-10, Middle Section, Science & Technology Park, Nanshan District, Shenzhen, Guangdong, China 518057 t (86-755) 26012053 f (86-755) 26710594 www.sgsgroup.com.cn  
 中国·广东·深圳市南山区科技园中区M-10栋1号厂房 邮编: 518057 t (86-755) 26012053 f (86-755) 26710594 sgs.china@sgs.com

Polarity: Horizontal; Modulation:802.11ax(Full RU0); Bandwidth:40MHz; Channel:High

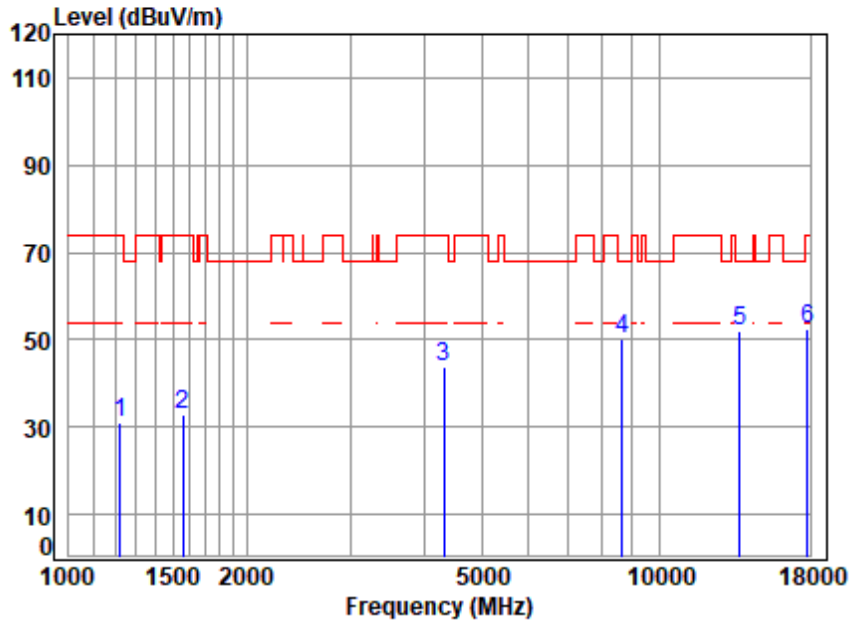

Site : chamber  
 Condition: 3m HORIZONTAL  
 Job No : 00384AT/00385AT  
 Mode : 6845 TX RSE  
 Note : 6E WIFI 11AX40

	Freq	Cable Loss	Ant Factor	Preamp Factor	Read Level	Limit Level	Over Limit	Remark
	MHz	dB	dB/m	dB	dBuV	dBuV/m	dBuV/m	dB
1	1220.714	3.62	24.69	38.34	41.26	31.23	74.00	-42.77 peak
2	1560.673	4.15	26.96	38.40	40.10	32.81	74.00	-41.19 peak
3	4316.859	7.00	34.13	35.86	38.36	43.63	74.00	-30.37 peak
4	8638.399	11.29	36.90	37.24	39.08	50.03	68.20	-18.17 peak
5	13690.000	13.72	39.08	37.23	36.47	52.04	68.20	-16.16 peak
6	17844.590	15.06	43.90	37.64	31.02	52.34	74.00	-21.66 peak



Unless otherwise agreed in writing, this document is issued by the Company subject to its General Conditions of Service printed overleaf, available on request or accessible at <https://www.sgs.com/en/Terms-and-Conditions>. Attention is drawn to the limitation of liability, indemnification and jurisdiction issues defined therein. Any holder of this document is advised that information contained hereon reflects the Company's findings at the time of its intervention only and within the limits of Client's instructions, if any. The Company's sole responsibility is to its Client and this document does not exonerate parties to a transaction from exercising all their rights and obligations under the transaction documents. This document cannot be reproduced except in full, without prior written approval of the Company. Any unauthorized alteration, forgery or falsification of the content or appearance of this document is unlawful and offenders may be prosecuted to the fullest extent of the law. Unless otherwise stated the results shown in this test report refer only to the sample(s) tested and such sample(s) are retained for 30 days only.

Attention: To check the authenticity of testing /inspection report & certificate, please contact us at telephone: (86-755) 8307 1443, or email: CN.Doccheck@sgs.com

No.1 Workshop, M-10, Middle Section, Science & Technology Park, Nanshan District, Shenzhen, Guangdong, China 518057 t (86-755) 26012053 f (86-755) 26710594 www.sgsgroup.com.cn  
 中国·广东·深圳市南山区科技园中区M-10栋1号厂房 邮编: 518057 t (86-755) 26012053 f (86-755) 26710594 sgs.china@sgs.com

Polarity: Vertical; Modulation:802.11ax(Full RU0); Bandwidth:40MHz; Channel:High

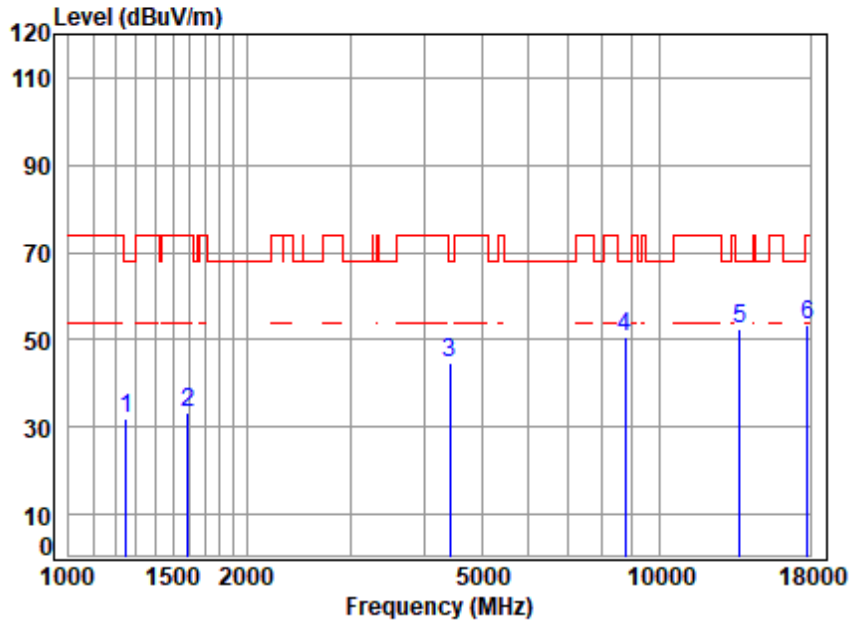

Site : chamber  
 Condition: 3m VERTICAL  
 Job No : 00384AT/00385AT  
 Mode : 6845 TX RSE  
 Note : 6E WIFI 11AX40

	Freq	Cable Loss	Ant Factor	Preamp Factor	Read Level	Limit Level	Over Limit	Remark
	MHz	dB	dB/m	dB	dBuV	dBuV/m	dBuV/m	dB
1	1249.269	3.67	25.09	38.35	41.65	32.06	68.20	-36.14 peak
2	1592.571	4.19	26.83	38.40	40.61	33.23	74.00	-40.77 peak
3	4417.841	7.07	34.59	35.78	38.70	44.58	68.20	-23.62 peak
4	8738.852	11.47	36.90	37.35	39.46	50.48	68.20	-17.72 peak
5	13690.000	13.72	39.08	37.23	36.67	52.24	68.20	-15.96 peak
6	17793.090	15.03	43.89	37.63	31.94	53.23	74.00	-20.77 peak



Unless otherwise agreed in writing, this document is issued by the Company subject to its General Conditions of Service printed overleaf, available on request or accessible at <https://www.sgs.com/en/Terms-and-Conditions>. Attention is drawn to the limitation of liability, indemnification and jurisdiction issues defined therein. Any holder of this document is advised that information contained hereon reflects the Company's findings at the time of its intervention only and within the limits of Client's instructions, if any. The Company's sole responsibility is to its Client and this document does not exonerate parties to a transaction from exercising all their rights and obligations under the transaction documents. This document cannot be reproduced except in full, without prior written approval of the Company. Any unauthorized alteration, forgery or falsification of the content or appearance of this document is unlawful and offenders may be prosecuted to the fullest extent of the law. Unless otherwise stated the results shown in this test report refer only to the sample(s) tested and such sample(s) are retained for 30 days only.

Attention: To check the authenticity of testing /inspection report & certificate, please contact us at telephone: (86-755) 8307 1443, or email: CN.Doccheck@sgs.com

No.1 Workshop, M-10, Middle Section, Science & Technology Park, Nanshan District, Shenzhen, Guangdong, China 518057 t (86-755) 26012053 f (86-755) 26710594 www.sgs.com.cn  
 中国·广东·深圳市南山区科技园中区M-10栋1号厂房 邮编: 518057 t (86-755) 26012053 f (86-755) 26710594 sgs.china@sgs.com



Polarity: Horizontal; Modulation:802.11ax(Full RU0); Bandwidth:80MHz; Channel:Low

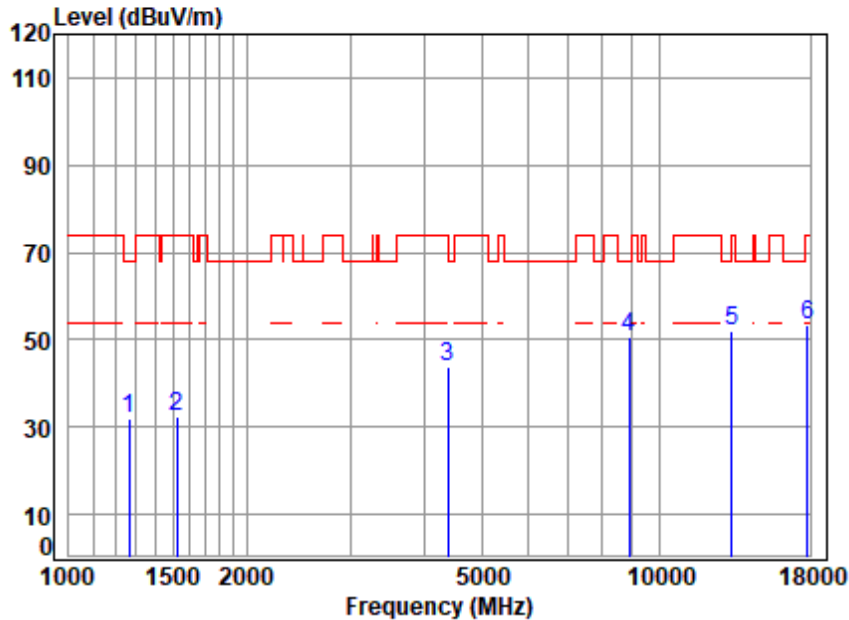

Site : chamber  
 Condition: 3m HORIZONTAL  
 Job No : 00384AT/00385AT  
 Mode : 6625 TX RSE  
 Note : 6E WIFI 11AX80

	Freq	Cable Loss	Ant Factor	Preamp Factor	Read Level	Limit Level	Over Line	Over Limit	Remark
	MHz	dB	dB/m	dB	dBuV	dBuV/m	dBuV/m	dB	
1	1267.454	3.70	25.00	38.35	41.58	31.93	68.20	-36.27	peak
2	1525.000	4.10	26.90	38.39	39.98	32.59	74.00	-41.41	peak
3	4379.699	7.04	34.64	35.81	37.71	43.58	74.00	-30.42	peak
4	8891.725	11.73	37.20	37.50	39.41	50.84	68.20	-17.36	peak
5	p13250.000	13.61	38.60	37.25	37.01	51.97	68.20	-16.23	peak
6	17793.090	15.03	43.89	37.63	32.07	53.36	74.00	-20.64	peak



Unless otherwise agreed in writing, this document is issued by the Company subject to its General Conditions of Service printed overleaf, available on request or accessible at <https://www.sgs.com/en/Terms-and-Conditions>. Attention is drawn to the limitation of liability, indemnification and jurisdiction issues defined therein. Any holder of this document is advised that information contained hereon reflects the Company's findings at the time of its intervention only and within the limits of Client's instructions, if any. The Company's sole responsibility is to its Client and this document does not exonerate parties to a transaction from exercising all their rights and obligations under the transaction documents. This document cannot be reproduced except in full, without prior written approval of the Company. Any unauthorized alteration, forgery or falsification of the content or appearance of this document is unlawful and offenders may be prosecuted to the fullest extent of the law. Unless otherwise stated the results shown in this test report refer only to the sample(s) tested and such sample(s) are retained for 30 days only.  
 Attention: To check the authenticity of testing /inspection report & certificate, please contact us at telephone: (86-755) 8307 1443, or email: CN.Doccheck@sgs.com  
 No.1 Workshop, M-10, Middle Section, Science & Technology Park, Nanshan District, Shenzhen, Guangdong, China 518057 t (86-755) 26012053 f (86-755) 26710594 www.sgs.com.cn  
 中国·广东·深圳市南山区科技园中区M-10栋1号厂房 邮编: 518057 t (86-755) 26012053 f (86-755) 26710594 sgs.china@sgs.com

Polarity: Vertical; Modulation:802.11ax(Full RU0); Bandwidth:80MHz; Channel:Low

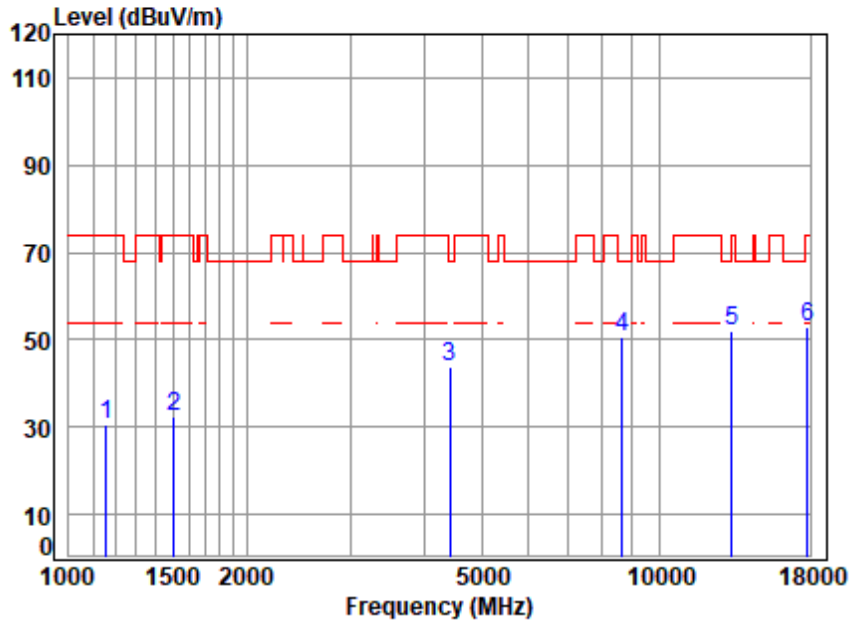

Site : chamber  
 Condition: 3m VERTICAL  
 Job No : 00384AT/00385AT  
 Mode : 6625 TX RSE  
 Note : 6E WIFI 11AX80

	Freq	Cable Loss	Ant Factor	Preamp Factor	Read Level	Limit Level	Over Line	Over Limit	Remark
	MHz	dB	dB/m	dB	dBuV	dBuV/m	dBuV/m	dB	
1	1158.828	3.51	23.99	38.33	41.56	30.73	74.00	-43.27	peak
2	1507.470	4.07	26.83	38.39	40.05	32.56	74.00	-41.44	peak
3	4417.841	7.07	34.59	35.78	37.92	43.80	68.20	-24.40	peak
4	8638.399	11.29	36.90	37.24	39.60	50.55	68.20	-17.65	peak
5	13250.000	13.61	38.60	37.25	37.05	52.01	68.20	-16.19	peak
6	17844.590	15.06	43.90	37.64	31.59	52.91	74.00	-21.09	peak



Unless otherwise agreed in writing, this document is issued by the Company subject to its General Conditions of Service printed overleaf, available on request or accessible at <https://www.sgs.com/en/Terms-and-Conditions>. Attention is drawn to the limitation of liability, indemnification and jurisdiction issues defined therein. Any holder of this document is advised that information contained hereon reflects the Company's findings at the time of its intervention only and within the limits of Client's instructions, if any. The Company's sole responsibility is to its Client and this document does not exonerate parties to a transaction from exercising all their rights and obligations under the transaction documents. This document cannot be reproduced except in full, without prior written approval of the Company. Any unauthorized alteration, forgery or falsification of the content or appearance of this document is unlawful and offenders may be prosecuted to the fullest extent of the law. Unless otherwise stated the results shown in this test report refer only to the sample(s) tested and such sample(s) are retained for 30 days only.

Attention: To check the authenticity of testing /inspection report & certificate, please contact us at telephone: (86-755) 8307 1443, or email: CN.Doccheck@sgs.com  
 No.1 Workshop, M-10, Middle Section, Science & Technology Park, Nanshan District, Shenzhen, Guangdong, China 518057 t (86-755) 26012053 f (86-755) 26710594 www.sgs.com.cn  
 中国·广东·深圳市南山区科技园中区M-10栋1号厂房 邮编: 518057 t (86-755) 26012053 f (86-755) 26710594 sgs.china@sgs.com

Polarity: Horizontal; Modulation:802.11ax(Full RU0); Bandwidth:80MHz; Channel:middle

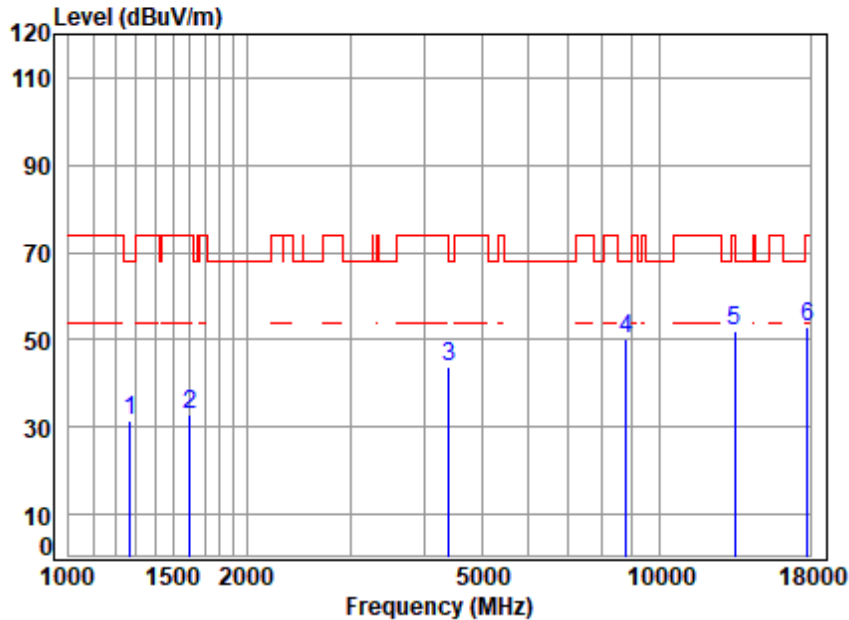

Site : chamber  
 Condition: 3m HORIZONTAL  
 Job No : 00384AT/00385AT  
 Mode : 6705 TX RSE  
 Note : 6E WIFI 11AX80

	Freq	Cable Loss	Ant Factor	Preamp Factor	Read Level	Limit Level	Over Limit	Remark
	MHz	dB	dB/m	dB	dBuV	dBuV/m	dBuV/m	dB
1	1271.123	3.71	24.97	38.35	41.12	31.45	68.20	-36.75 peak
2	1606.441	4.21	26.74	38.40	40.46	33.01	74.00	-40.99 peak
3	4405.090	7.06	34.74	35.79	37.98	43.99	68.20	-24.21 peak
4	8789.516	11.55	37.06	37.40	38.93	50.14	68.20	-18.06 peak
5	13410.000	13.65	38.80	37.24	36.77	51.98	68.20	-16.22 peak
6	17844.590	15.06	43.90	37.64	31.72	53.04	74.00	-20.96 peak



Unless otherwise agreed in writing, this document is issued by the Company subject to its General Conditions of Service printed overleaf, available on request or accessible at <https://www.sgs.com/en/Terms-and-Conditions>. Attention is drawn to the limitation of liability, indemnification and jurisdiction issues defined therein. Any holder of this document is advised that information contained hereon reflects the Company's findings at the time of its intervention only and within the limits of Client's instructions, if any. The Company's sole responsibility is to its Client and this document does not exonerate parties to a transaction from exercising all their rights and obligations under the transaction documents. This document cannot be reproduced except in full, without prior written approval of the Company. Any unauthorized alteration, forgery or falsification of the content or appearance of this document is unlawful and offenders may be prosecuted to the fullest extent of the law. Unless otherwise stated the results shown in this test report refer only to the sample(s) tested and such sample(s) are retained for 30 days only.

Attention: To check the authenticity of testing /inspection report & certificate, please contact us at telephone: (86-755) 8307 1443, or email: CN.Doccheck@sgs.com

No.1 Workshop, M-10, Middle Section, Science & Technology Park, Nanshan District, Shenzhen, Guangdong, China 518057 t (86-755) 26012053 f (86-755) 26710594 www.sgsgroup.com.cn  
 中国·广东·深圳市南山区科技园中区M-10栋1号厂房 邮编: 518057 t (86-755) 26012053 f (86-755) 26710594 sgs.china@sgs.com



Polarity: Vertical; Modulation:802.11ax(Full RU0); Bandwidth:80MHz; Channel:middle

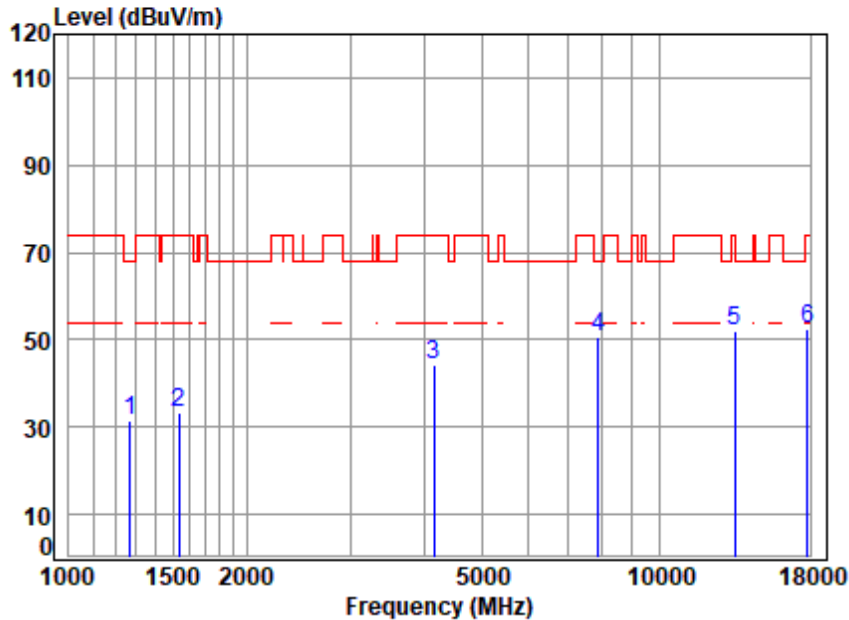

Site : chamber  
 Condition: 3m VERTICAL  
 Job No : 00384AT/00385AT  
 Mode : 6705 TX RSE  
 Note : 6E WIFI 11AX80

	Freq	Cable Loss	Ant Factor	Preamp Factor	Read Level	Limit Level	Over Limit	Remark
	MHz	dB	dB/m	dB	dBuV	dBuV/m	dBuV/m	dB
1	1271.123	3.71	24.97	38.35	40.97	31.30	68.20	-36.90 peak
2	1538.281	4.12	26.95	38.39	40.72	33.40	74.00	-40.60 peak
3	4157.664	6.89	33.80	35.98	39.43	44.14	74.00	-29.86 peak
4	7875.254	9.96	36.45	36.44	40.68	50.65	68.20	-17.55 peak
5	13410.000	13.65	38.80	37.24	36.61	51.82	68.20	-16.38 peak
6	17793.090	15.03	43.89	37.63	31.09	52.38	74.00	-21.62 peak



Unless otherwise agreed in writing, this document is issued by the Company subject to its General Conditions of Service printed overleaf, available on request or accessible at <https://www.sgs.com/en/Terms-and-Conditions>. Attention is drawn to the limitation of liability, indemnification and jurisdiction issues defined therein. Any holder of this document is advised that information contained hereon reflects the Company's findings at the time of its intervention only and within the limits of Client's instructions, if any. The Company's sole responsibility is to its Client and this document does not exonerate parties to a transaction from exercising all their rights and obligations under the transaction documents. This document cannot be reproduced except in full, without prior written approval of the Company. Any unauthorized alteration, forgery or falsification of the content or appearance of this document is unlawful and offenders may be prosecuted to the fullest extent of the law. Unless otherwise stated the results shown in this test report refer only to the sample(s) tested and such sample(s) are retained for 30 days only.

Attention: To check the authenticity of testing /inspection report & certificate, please contact us at telephone: (86-755) 8307 1443, or email: CN.Doccheck@sgs.com  
 No.1 Workshop, M-10, Middle Section, Science & Technology Park, Nanshan District, Shenzhen, Guangdong, China 518057 t (86-755) 26012053 f (86-755) 26710594 www.sgs.com.cn  
 中国·广东·深圳市南山区科技园中区M-10栋1号厂房 邮编: 518057 t (86-755) 26012053 f (86-755) 26710594 sgs.china@sgs.com

Polarity: Horizontal; Modulation:802.11ax(Full RU0); Bandwidth:80MHz; Channel:High

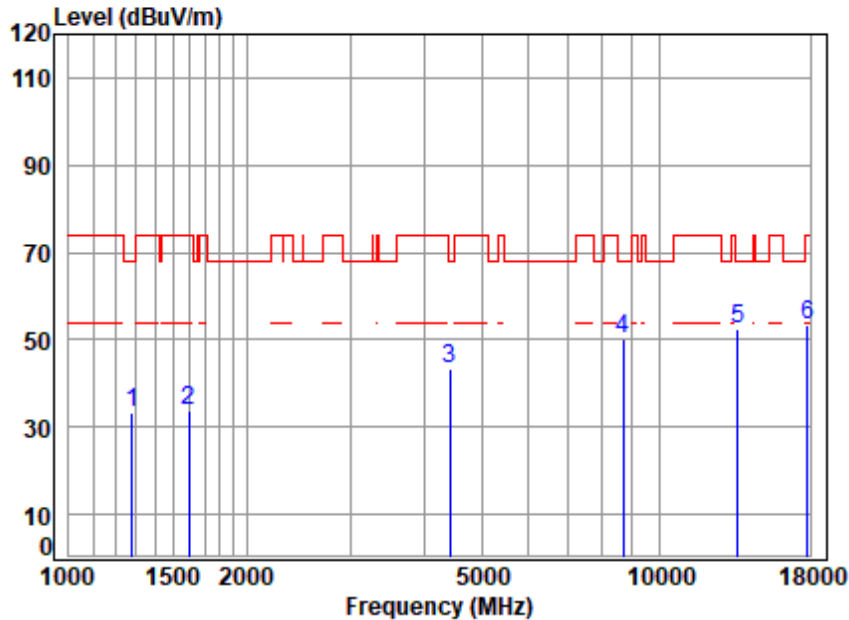

Site : chamber  
 Condition: 3m HORIZONTAL  
 Job No : 00384AT/00385AT  
 Mode : 6785 TX RSE  
 Note : 6E WIFI 11AX80

	Freq	Cable Loss	Ant Factor	Preamp Factor	Read Level	Limit Level	Over Line	Over Limit	Remark
	MHz	dB	dB/m	dB	dBuV	dBuV/m	dBuV/m	dB	
1	1278.492	3.72	24.93	38.35	42.93	33.23	68.20	-34.97	peak
2	1597.181	4.20	26.81	38.40	41.11	33.72	74.00	-40.28	peak
3	4417.841	7.07	34.59	35.78	37.60	43.48	68.20	-24.72	peak
4	8688.480	11.38	36.90	37.30	39.13	50.11	68.20	-18.09	peak
5	13570.000	13.69	38.87	37.24	37.02	52.34	68.20	-15.86	peak
6	17793.090	15.03	43.89	37.63	31.89	53.18	74.00	-20.82	peak



Unless otherwise agreed in writing, this document is issued by the Company subject to its General Conditions of Service printed overleaf, available on request or accessible at <https://www.sgs.com/en/Terms-and-Conditions>. Attention is drawn to the limitation of liability, indemnification and jurisdiction issues defined therein. Any holder of this document is advised that information contained hereon reflects the Company's findings at the time of its intervention only and within the limits of Client's instructions, if any. The Company's sole responsibility is to its Client and this document does not exonerate parties to a transaction from exercising all their rights and obligations under the transaction documents. This document cannot be reproduced except in full, without prior written approval of the Company. Any unauthorized alteration, forgery or falsification of the content or appearance of this document is unlawful and offenders may be prosecuted to the fullest extent of the law. Unless otherwise stated the results shown in this test report refer only to the sample(s) tested and such sample(s) are retained for 30 days only.

Attention: To check the authenticity of testing /inspection report & certificate, please contact us at telephone: (86-755) 8307 1443, or email: CN.Doccheck@sgs.com

No.1 Workshop, M-10, Middle Section, Science & Technology Park, Nanshan District, Shenzhen, Guangdong, China 518057 t (86-755) 26012053 f (86-755) 26710594 www.sgs.com.cn  
 中国·广东·深圳市南山区科技园中区M-10栋1号厂房 邮编: 518057 t (86-755) 26012053 f (86-755) 26710594 sgs.china@sgs.com

Polarity: Vertical; Modulation:802.11ax(Full RU0); Bandwidth:80MHz; Channel:High

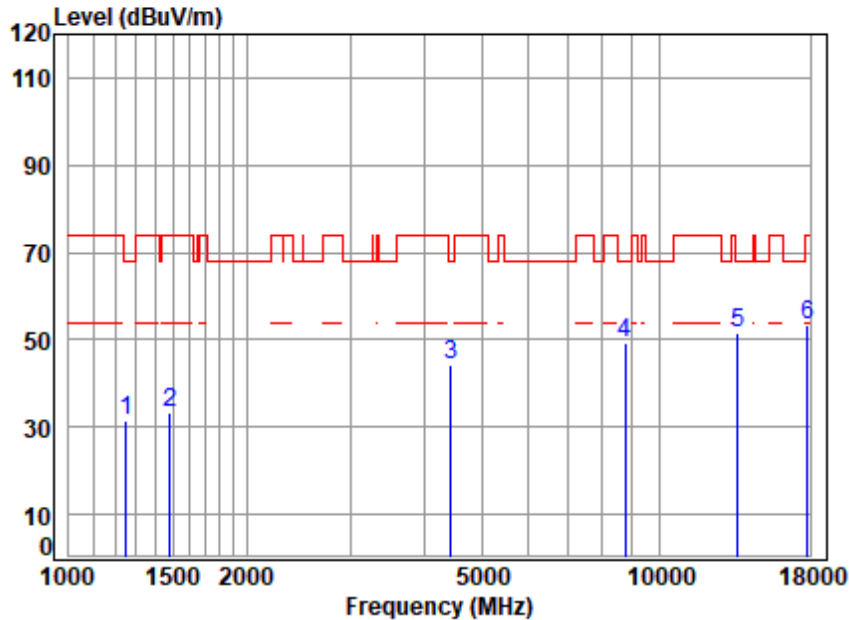

Site : chamber  
 Condition: 3m VERTICAL  
 Job No : 00384AT/00385AT  
 Mode : 6785 TX RSE  
 Note : 6E WIFI 11AX80

	Freq	Cable Loss	Ant Factor	Preamp Factor	Read Level	Limit Level	Over Line	Over Limit	Remark
	MHz	dB	dB/m	dB	dBuV	dBuV/m	dBuV/m	dB	
1	1249.269	3.67	25.09	38.35	41.18	31.59	68.20	-36.61	peak
2	1481.553	4.03	26.28	38.39	41.23	33.15	74.00	-40.85	peak
3	4430.628	7.08	34.43	35.77	38.52	44.26	68.20	-23.94	peak
4	8738.852	11.47	36.90	37.35	38.41	49.43	68.20	-18.77	peak
5	13570.000	13.69	38.87	37.24	36.38	51.70	68.20	-16.50	peak
6	17793.090	15.03	43.89	37.63	31.91	53.20	74.00	-20.80	peak



Unless otherwise agreed in writing, this document is issued by the Company subject to its General Conditions of Service printed overleaf, available on request or accessible at <https://www.sgs.com/en/Terms-and-Conditions>. Attention is drawn to the limitation of liability, indemnification and jurisdiction issues defined therein. Any holder of this document is advised that information contained hereon reflects the Company's findings at the time of its intervention only and within the limits of Client's instructions, if any. The Company's sole responsibility is to its Client and this document does not exonerate parties to a transaction from exercising all their rights and obligations under the transaction documents. This document cannot be reproduced except in full, without prior written approval of the Company. Any unauthorized alteration, forgery or falsification of the content or appearance of this document is unlawful and offenders may be prosecuted to the fullest extent of the law. Unless otherwise stated the results shown in this test report refer only to the sample(s) tested and such sample(s) are retained for 30 days only.  
 Attention: To check the authenticity of testing /inspection report & certificate, please contact us at telephone: (86-755) 8307 1443, or email: CN.Doccheck@sgs.com  
 No.1 Workshop, M-10, Middle Section, Science & Technology Park, Nanshan District, Shenzhen, Guangdong, China 518057 t (86-755) 26012053 f (86-755) 26710594 www.sgs.com.cn  
 中国·广东·深圳市南山区科技园中区M-10栋1号厂房 邮编: 518057 t (86-755) 26012053 f (86-755) 26710594 sgs.china@sgs.com



Polarity: Horizontal; Modulation:802.11ax(Full RU0); Bandwidth:160MHz; Channel:middle

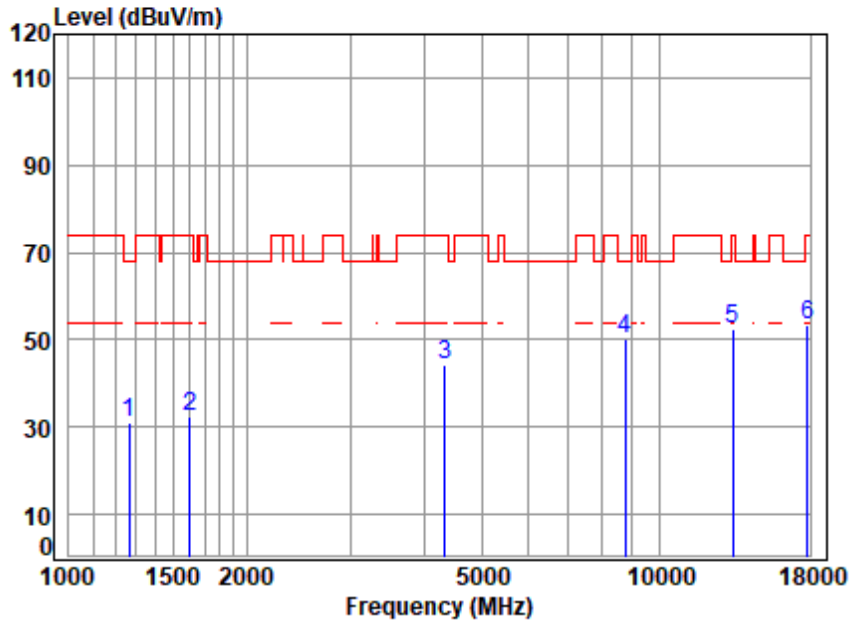

Site : chamber  
 Condition: 3m HORIZONTAL  
 Job No : 00384AT/00385AT  
 Mode : 6665 TX RSE  
 Note : 6E WIFI 11AX160

	Freq	Cable Loss	Ant Factor	Preamp Factor	Read Level	Limit Level	Over Line	Over Limit	Remark
	MHz	dB	dB/m	dB	dBuV	dBuV/m	dBuV/m	dB	
1	1263.796	3.69	25.02	38.35	40.74	31.10	68.20	-37.10	peak
2	1606.441	4.21	26.74	38.40	39.90	32.45	74.00	-41.55	peak
3	4341.886	7.02	34.34	35.84	38.60	44.12	74.00	-29.88	peak
4 p	8738.852	11.47	36.90	37.35	39.34	50.36	68.20	-17.84	peak
5	13330.000	13.63	38.66	37.25	37.43	52.47	74.00	-21.53	peak
6	17844.590	15.06	43.90	37.64	31.90	53.22	74.00	-20.78	peak



Unless otherwise agreed in writing, this document is issued by the Company subject to its General Conditions of Service printed overleaf, available on request or accessible at <https://www.sgs.com/en/Terms-and-Conditions>. Attention is drawn to the limitation of liability, indemnification and jurisdiction issues defined therein. Any holder of this document is advised that information contained hereon reflects the Company's findings at the time of its intervention only and within the limits of Client's instructions, if any. The Company's sole responsibility is to its Client and this document does not exonerate parties to a transaction from exercising all their rights and obligations under the transaction documents. This document cannot be reproduced except in full, without prior written approval of the Company. Any unauthorized alteration, forgery or falsification of the content or appearance of this document is unlawful and offenders may be prosecuted to the fullest extent of the law. Unless otherwise stated the results shown in this test report refer only to the sample(s) tested and such sample(s) are retained for 30 days only.

Attention: To check the authenticity of testing /inspection report & certificate, please contact us at telephone: (86-755) 8307 1443, or email: CN.Doccheck@sgs.com  
 No.1 Workshop, M-10, Middle Section, Science & Technology Park, Nanshan District, Shenzhen, Guangdong, China 518057 t (86-755) 26012053 f (86-755) 26710594 www.sgs.com.cn  
 中国·广东·深圳市南山区科技园中区M-10栋1号厂房 邮编: 518057 t (86-755) 26012053 f (86-755) 26710594 sgs.china@sgs.com

Polarity: Vertical; Modulation:802.11ax(Full RU0); Bandwidth:160MHz; Channel:middle

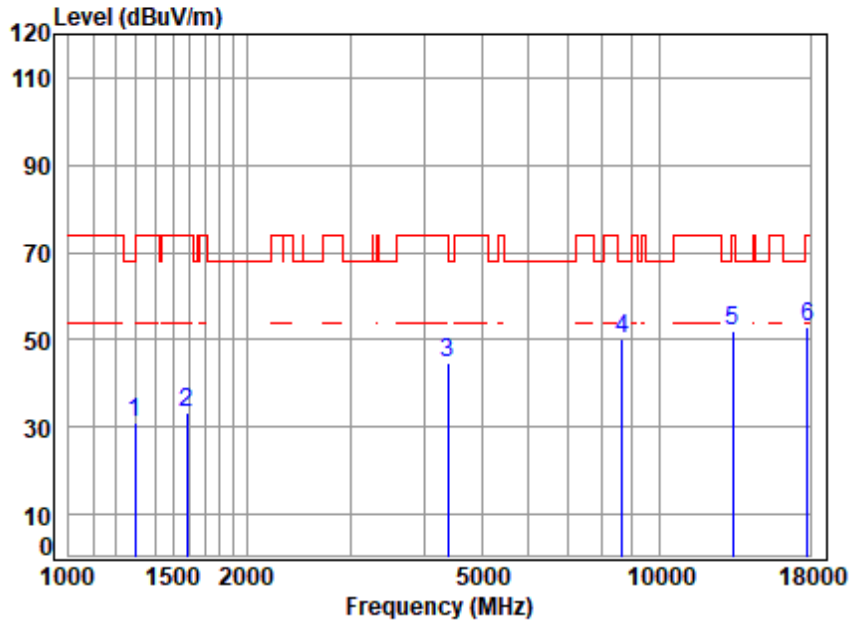

Site : chamber  
 Condition: 3m VERTICAL  
 Job No : 00384AT/00385AT  
 Mode : 6665 TX RSE  
 Note : 6E WIFI 11AX160

	Freq	Cable Loss	Ant Factor	Preamp Factor	Read Level	Limit Level	Over Limit	Remark
	MHz	dB	dB/m	dB	dBuV	dBuV/m	dBuV/m	dB
1	1293.359	3.74	24.84	38.36	40.91	31.13	68.20	-37.07 peak
2	1583.392	4.18	26.87	38.40	40.84	33.49	74.00	-40.51 peak
3	4392.376	7.05	34.74	35.80	38.86	44.85	74.00	-29.15 peak
4 p	8663.404	11.33	36.90	37.27	39.33	50.29	68.20	-17.91 peak
5	13330.000	13.63	38.66	37.25	36.93	51.97	74.00	-22.03 peak
6	17844.590	15.06	43.90	37.64	31.54	52.86	74.00	-21.14 peak



Unless otherwise agreed in writing, this document is issued by the Company subject to its General Conditions of Service printed overleaf, available on request or accessible at <https://www.sgs.com/en/Terms-and-Conditions>. Attention is drawn to the limitation of liability, indemnification and jurisdiction issues defined therein. Any holder of this document is advised that information contained hereon reflects the Company's findings at the time of its intervention only and within the limits of Client's instructions, if any. The Company's sole responsibility is to its Client and this document does not exonerate parties to a transaction from exercising all their rights and obligations under the transaction documents. This document cannot be reproduced except in full, without prior written approval of the Company. Any unauthorized alteration, forgery or falsification of the content or appearance of this document is unlawful and offenders may be prosecuted to the fullest extent of the law. Unless otherwise stated the results shown in this test report refer only to the sample(s) tested and such sample(s) are retained for 30 days only.  
 Attention: To check the authenticity of testing /inspection report & certificate, please contact us at telephone: (86-755) 8307 1443, or email: CN.Doccheck@sgs.com  
 No.1 Workshop, M-10, Middle Section, Science & Technology Park, Nanshan District, Shenzhen, Guangdong, China 518057 t (86-755) 26012053 f (86-755) 26710594 www.sgsgroup.com.cn  
 中国·广东·深圳市南山区科技园中区M-10栋1号厂房 邮编: 518057 t (86-755) 26012053 f (86-755) 26710594 sgs.china@sgs.com

Polarity: Horizontal; Modulation:802.11ax(Full RU0); Bandwidth:20MHz; Channel:Low

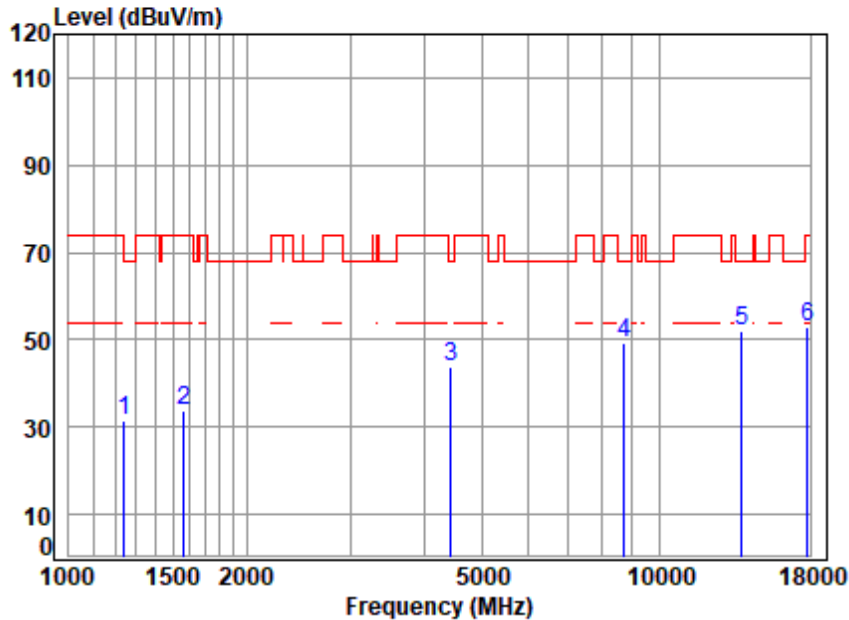

Site : chamber  
 Condition: 3m HORIZONTAL  
 Job No : 00384AT/00385AT  
 Mode : 6895 TX RSE  
 Note : 6E WIFI 11AX20

	Freq	Cable Loss	Ant Factor	Preamp Factor	Read Level	Limit Level	Over Line	Over Limit	Remark
	MHz	dB	dB/m	dB	dBuV	dBuV/m	dBuV/m	dB	
1	1242.068	3.66	24.99	38.35	40.99	31.29	68.20	-36.91	peak
2	1569.721	4.16	26.92	38.40	41.04	33.72	74.00	-40.28	peak
3	4430.628	7.08	34.43	35.77	38.20	43.94	68.20	-24.26	peak
4	8713.630	11.42	36.90	37.32	38.42	49.42	68.20	-18.78	peak
5	13790.000	13.74	39.28	37.22	36.31	52.11	68.20	-16.09	peak
6	17844.590	15.06	43.90	37.64	31.66	52.98	74.00	-21.02	peak



Unless otherwise agreed in writing, this document is issued by the Company subject to its General Conditions of Service printed overleaf, available on request or accessible at <https://www.sgs.com/en/Terms-and-Conditions>. Attention is drawn to the limitation of liability, indemnification and jurisdiction issues defined therein. Any holder of this document is advised that information contained hereon reflects the Company's findings at the time of its intervention only and within the limits of Client's instructions, if any. The Company's sole responsibility is to its Client and this document does not exonerate parties to a transaction from exercising all their rights and obligations under the transaction documents. This document cannot be reproduced except in full, without prior written approval of the Company. Any unauthorized alteration, forgery or falsification of the content or appearance of this document is unlawful and offenders may be prosecuted to the fullest extent of the law. Unless otherwise stated the results shown in this test report refer only to the sample(s) tested and such sample(s) are retained for 30 days only.

Attention: To check the authenticity of testing /inspection report & certificate, please contact us at telephone: (86-755) 8307 1443, or email: CN.Doccheck@sgs.com

No.1 Workshop, M-10, Middle Section, Science & Technology Park, Nanshan District, Shenzhen, Guangdong, China 518057 t (86-755) 26012053 f (86-755) 26710594 www.sgsgroup.com.cn  
 中国·广东·深圳市南山区科技园中区M-10栋1号厂房 邮编: 518057 t (86-755) 26012053 f (86-755) 26710594 sgs.china@sgs.com



Polarity: Vertical; Modulation:802.11ax(Full RU0); Bandwidth:20MHz; Channel:Low

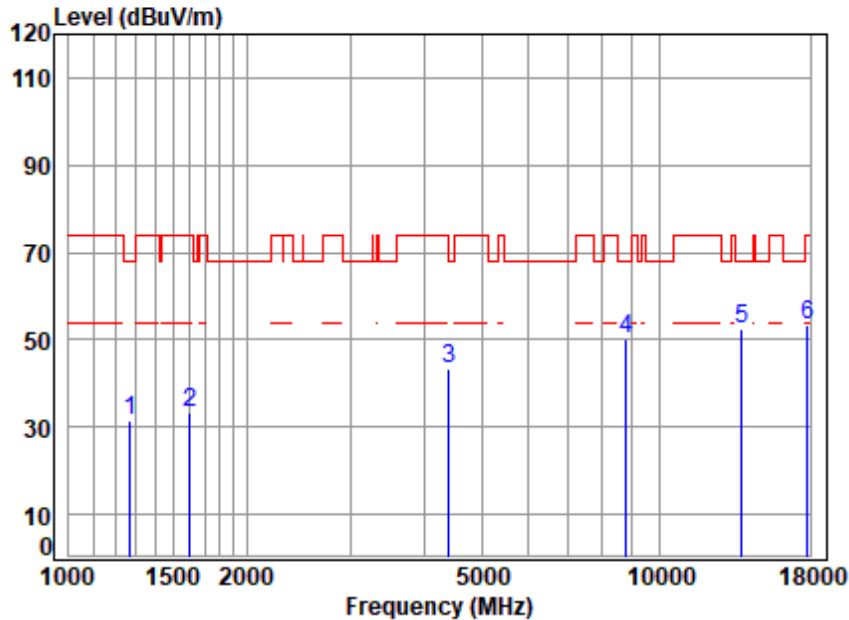

Site : chamber  
 Condition: 3m VERTICAL  
 Job No : 00384AT/00385AT  
 Mode : 6895 TX RSE  
 Note : 6E WIFI 11AX20

	Freq	Cable Loss	Ant Factor	Preamp Factor	Read Level	Limit Level	Over Limit	Remark
	MHz	dB	dB/m	dB	dBuV	dBuV/m	dBuV/m	dB
1	1271.123	3.71	24.97	38.35	40.95	31.28	68.20	-36.92 peak
2	1606.441	4.21	26.74	38.40	40.68	33.23	74.00	-40.77 peak
3	4405.090	7.06	34.74	35.79	37.39	43.40	68.20	-24.80 peak
4	8789.516	11.55	37.06	37.40	39.07	50.28	68.20	-17.92 peak
5	13790.000	13.74	39.28	37.22	36.51	52.31	68.20	-15.89 peak
6	17793.090	15.03	43.89	37.63	32.14	53.43	74.00	-20.57 peak



Unless otherwise agreed in writing, this document is issued by the Company subject to its General Conditions of Service printed overleaf, available on request or accessible at <https://www.sgs.com/en/Terms-and-Conditions>. Attention is drawn to the limitation of liability, indemnification and jurisdiction issues defined therein. Any holder of this document is advised that information contained hereon reflects the Company's findings at the time of its intervention only and within the limits of Client's instructions, if any. The Company's sole responsibility is to its Client and this document does not exonerate parties to a transaction from exercising all their rights and obligations under the transaction documents. This document cannot be reproduced except in full, without prior written approval of the Company. Any unauthorized alteration, forgery or falsification of the content or appearance of this document is unlawful and offenders may be prosecuted to the fullest extent of the law. Unless otherwise stated the results shown in this test report refer only to the sample(s) tested and such sample(s) are retained for 30 days only.

Attention: To check the authenticity of testing /inspection report & certificate, please contact us at telephone: (86-755) 8307 1443, or email: CN.Doccheck@sgs.com  
 No.1 Workshop, M-10, Middle Section, Science & Technology Park, Nanshan District, Shenzhen, Guangdong, China 518057 t (86-755) 26012053 f (86-755) 26710594 www.sgs.com.cn  
 中国·广东·深圳市南山区科技园中区M-10栋1号厂房 邮编: 518057 t (86-755) 26012053 f (86-755) 26710594 sgs.china@sgs.com

Polarity: Horizontal; Modulation:802.11ax(Full RU0); Bandwidth:20MHz; Channel:middle

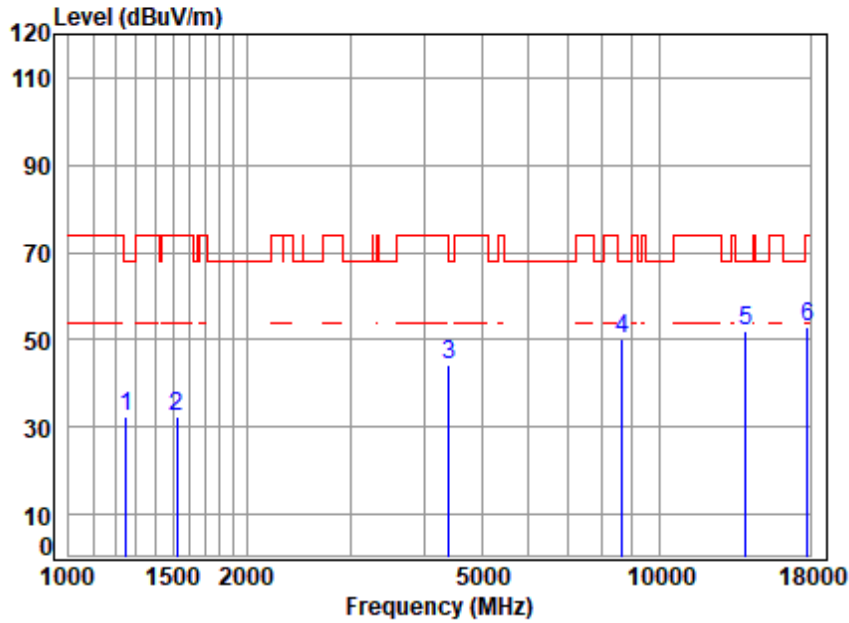

Site : chamber  
 Condition: 3m HORIZONTAL  
 Job No : 00384AT/00385AT  
 Mode : 6995 TX RSE  
 Note : 6E WIFI 11AX20

	Freq	Cable Loss	Ant Factor	Preamp Factor	Read Level	Limit Level	Over Limit	Remark
	MHz	dB	dB/m	dB	dBuV	dBuV/m	dBuV/m	dB
1	1249.269	3.67	25.09	38.35	41.88	32.29	68.20	-35.91 peak
2	1525.000	4.10	26.90	38.39	39.64	32.25	74.00	-41.75 peak
3	4405.090	7.06	34.74	35.79	38.41	44.42	68.20	-23.78 peak
4	8638.399	11.29	36.90	37.24	39.33	50.28	68.20	-17.92 peak
5	13990.000	13.79	39.68	37.21	35.95	52.21	68.20	-15.99 peak
6	17793.090	15.03	43.89	37.63	31.86	53.15	74.00	-20.85 peak



Unless otherwise agreed in writing, this document is issued by the Company subject to its General Conditions of Service printed overleaf, available on request or accessible at <https://www.sgs.com/en/Terms-and-Conditions>. Attention is drawn to the limitation of liability, indemnification and jurisdiction issues defined therein. Any holder of this document is advised that information contained hereon reflects the Company's findings at the time of its intervention only and within the limits of Client's instructions, if any. The Company's sole responsibility is to its Client and this document does not exonerate parties to a transaction from exercising all their rights and obligations under the transaction documents. This document cannot be reproduced except in full, without prior written approval of the Company. Any unauthorized alteration, forgery or falsification of the content or appearance of this document is unlawful and offenders may be prosecuted to the fullest extent of the law. Unless otherwise stated the results shown in this test report refer only to the sample(s) tested and such sample(s) are retained for 30 days only.

Attention: To check the authenticity of testing /inspection report & certificate, please contact us at telephone: (86-755) 8307 1443, or email: CN.Doccheck@sgs.com  
 No.1 Workshop, M-10, Middle Section, Science & Technology Park, Nanshan District, Shenzhen, Guangdong, China 518057 t (86-755) 26012053 f (86-755) 26710594 www.sgs.com.cn  
 中国·广东·深圳市南山区科技园中区M-10栋1号厂房 邮编: 518057 t (86-755) 26012053 f (86-755) 26710594 sgs.china@sgs.com

Polarity: Vertical; Modulation:802.11ax(Full RU0); Bandwidth:20MHz; Channel:middle

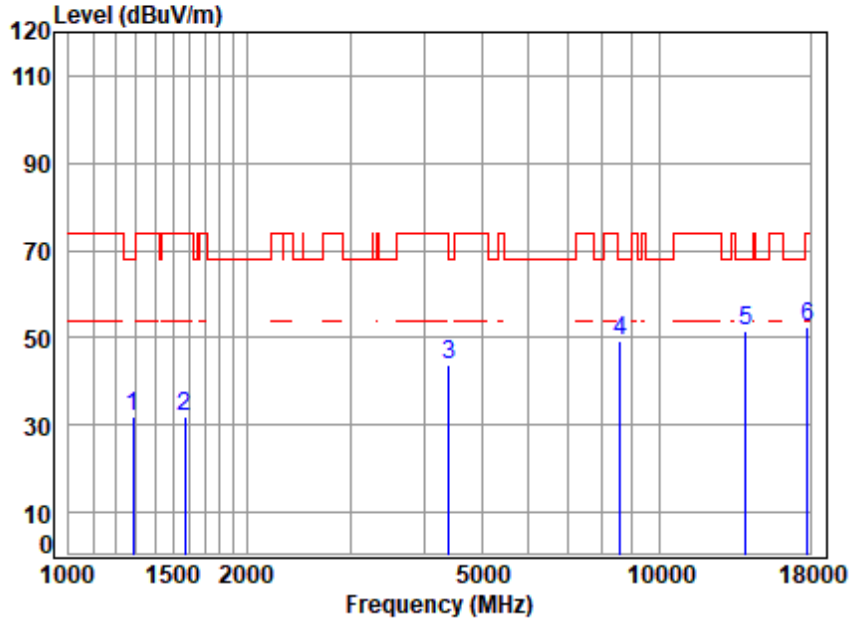

Site : chamber  
 Condition: 3m VERTICAL  
 Job No : 00384AT/00385AT  
 Mode : 6995 TX RSE  
 Note : 6E WIFI 11AX20

	Freq	Cable Loss	Ant Factor	Preamp Factor	Read Level	Limit Level	Over Limit	Remark
	MHz	dB	dB/m	dB	dBuV	dBuV/m	dBuV/m	dB
1	1285.904	3.73	24.88	38.35	41.67	31.93	68.20	-36.27 peak
2	1574.265	4.17	26.90	38.40	39.45	32.12	74.00	-41.88 peak
3	4405.090	7.06	34.74	35.79	38.01	44.02	68.20	-24.18 peak
4	8588.607	11.20	36.88	37.19	38.48	49.37	68.20	-18.83 peak
5	13990.000	13.79	39.68	37.21	35.36	51.62	68.20	-16.58 peak
6	17844.590	15.06	43.90	37.64	31.34	52.66	74.00	-21.34 peak



Unless otherwise agreed in writing, this document is issued by the Company subject to its General Conditions of Service printed overleaf, available on request or accessible at <https://www.sgs.com/en/Terms-and-Conditions>. Attention is drawn to the limitation of liability, indemnification and jurisdiction issues defined therein. Any holder of this document is advised that information contained hereon reflects the Company's findings at the time of its intervention only and within the limits of Client's instructions, if any. The Company's sole responsibility is to its Client and this document does not exonerate parties to a transaction from exercising all their rights and obligations under the transaction documents. This document cannot be reproduced except in full, without prior written approval of the Company. Any unauthorized alteration, forgery or falsification of the content or appearance of this document is unlawful and offenders may be prosecuted to the fullest extent of the law. Unless otherwise stated the results shown in this test report refer only to the sample(s) tested and such sample(s) are retained for 30 days only.

Attention: To check the authenticity of testing /inspection report & certificate, please contact us at telephone: (86-755) 8307 1443, or email: CN.Doccheck@sgs.com  
 No.1 Workshop, M-10, Middle Section, Science & Technology Park, Nanshan District, Shenzhen, Guangdong, China 518057 t (86-755) 26012053 f (86-755) 26710594 www.sgsgroup.com.cn  
 中国·广东·深圳市南山区科技园中区M-10栋1号厂房 邮编: 518057 t (86-755) 26012053 f (86-755) 26710594 sgs.china@sgs.com



Polarity: Horizontal; Modulation:802.11ax(Full RU0); Bandwidth:20MHz; Channel:High

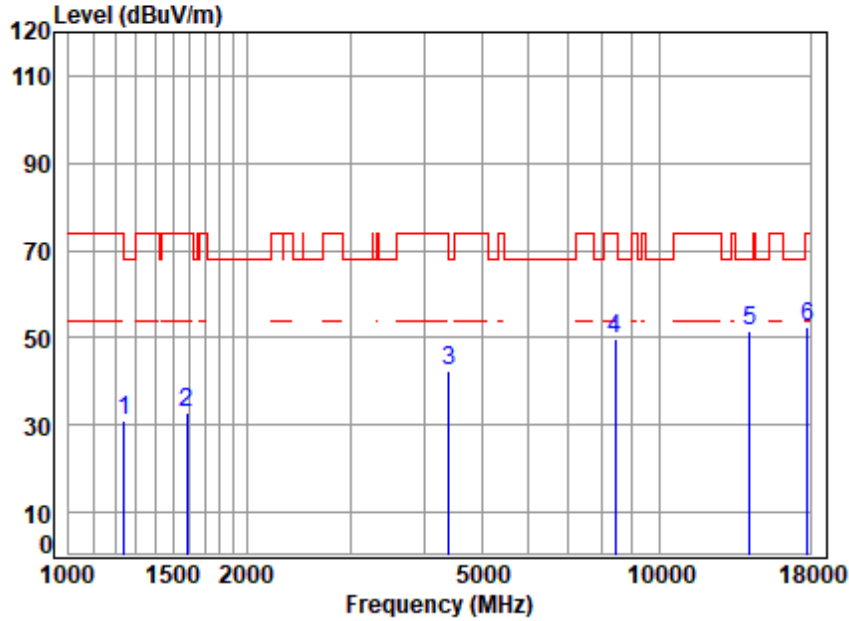

Site : chamber  
 Condition: 3m HORIZONTAL  
 Job No : 00384AT/00385AT  
 Mode : 7115 TX RSE  
 Note : 6E WIFI 11AX20

	Freq	Cable Loss	Ant Factor	Preamp Factor	Read Level	Limit Level	Over Line	Over Limit	Remark
	MHz	dB	dB/m	dB	dBuV	dBuV/m	dBuV/m	dB	
1	1242.068	3.66	24.99	38.35	40.78	31.08	68.20	-37.12	peak
2	1583.392	4.18	26.87	38.40	40.01	32.66	74.00	-41.34	peak
3	4405.090	7.06	34.74	35.79	36.61	42.62	68.20	-25.58	peak
4	8416.584	10.88	36.67	37.01	39.34	49.88	74.00	-24.12	peak
5	14230.000	13.85	39.89	37.16	35.18	51.76	68.20	-16.44	peak
6	17844.590	15.06	43.90	37.64	31.38	52.70	74.00	-21.30	peak



Unless otherwise agreed in writing, this document is issued by the Company subject to its General Conditions of Service printed overleaf, available on request or accessible at <https://www.sgs.com/en/Terms-and-Conditions>. Attention is drawn to the limitation of liability, indemnification and jurisdiction issues defined therein. Any holder of this document is advised that information contained hereon reflects the Company's findings at the time of its intervention only and within the limits of Client's instructions, if any. The Company's sole responsibility is to its Client and this document does not exonerate parties to a transaction from exercising all their rights and obligations under the transaction documents. This document cannot be reproduced except in full, without prior written approval of the Company. Any unauthorized alteration, forgery or falsification of the content or appearance of this document is unlawful and offenders may be prosecuted to the fullest extent of the law. Unless otherwise stated the results shown in this test report refer only to the sample(s) tested and such sample(s) are retained for 30 days only.

Attention: To check the authenticity of testing /inspection report & certificate, please contact us at telephone: (86-755) 8307 1443, or email: CN.Doccheck@sgs.com  
 No.1 Workshop, M-10, Middle Section, Science & Technology Park, Nanshan District, Shenzhen, Guangdong, China 518057 t (86-755) 26012053 f (86-755) 26710594 www.sgs.com.cn  
 中国·广东·深圳市南山区科技园中区M-10栋1号厂房 邮编: 518057 t (86-755) 26012053 f (86-755) 26710594 sgs.china@sgs.com

Polarity: Vertical; Modulation:802.11ax(Full RU0); Bandwidth:20MHz; Channel:High

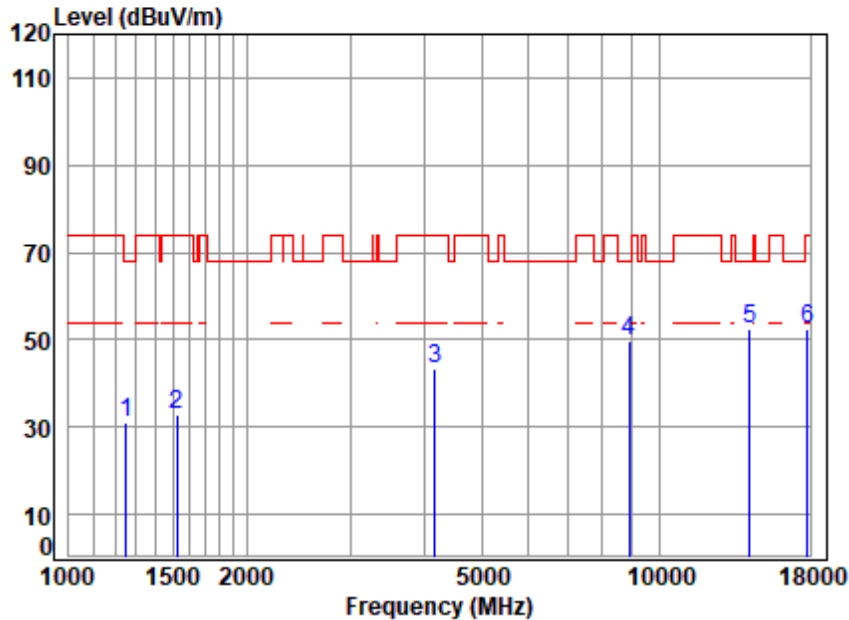

Site : chamber  
 Condition: 3m VERTICAL  
 Job No : 00384AT/00385AT  
 Mode : 7115 TX RSE  
 Note : 6E WIFI 11AX20

	Freq	Cable Loss	Ant Factor	Preamp Factor	Read Level	Limit Level	Over Limit	Remark
	MHz	dB	dB/m	dB	dBuV	dBuV/m	dBuV/m	dB
1	1249.269	3.67	25.09	38.35	40.56	30.97	68.20	-37.23 peak
2	1525.000	4.10	26.90	38.39	40.39	33.00	74.00	-41.00 peak
3	4169.698	6.90	33.80	35.97	38.68	43.41	74.00	-30.59 peak
4	8891.725	11.73	37.20	37.50	38.26	49.69	68.20	-18.51 peak
5	14230.000	13.85	39.89	37.16	35.77	52.35	68.20	-15.85 peak
6	17844.590	15.06	43.90	37.64	31.20	52.52	74.00	-21.48 peak



Unless otherwise agreed in writing, this document is issued by the Company subject to its General Conditions of Service printed overleaf, available on request or accessible at <https://www.sgs.com/en/Terms-and-Conditions>. Attention is drawn to the limitation of liability, indemnification and jurisdiction issues defined therein. Any holder of this document is advised that information contained hereon reflects the Company's findings at the time of its intervention only and within the limits of Client's instructions, if any. The Company's sole responsibility is to its Client and this document does not exonerate parties to a transaction from exercising all their rights and obligations under the transaction documents. This document cannot be reproduced except in full, without prior written approval of the Company. Any unauthorized alteration, forgery or falsification of the content or appearance of this document is unlawful and offenders may be prosecuted to the fullest extent of the law. Unless otherwise stated the results shown in this test report refer only to the sample(s) tested and such sample(s) are retained for 30 days only.

Attention: To check the authenticity of testing /inspection report & certificate, please contact us at telephone: (86-755) 8307 1443, or email: CN.Doccheck@sgs.com  
 No.1 Workshop, M-10, Middle Section, Science & Technology Park, Nanshan District, Shenzhen, Guangdong, China 518057 t (86-755) 26012053 f (86-755) 26710594 www.sgs.com.cn  
 中国·广东·深圳市南山区科技园中区M-10栋1号厂房 邮编: 518057 t (86-755) 26012053 f (86-755) 26710594 sgs.china@sgs.com

Polarity: Horizontal; Modulation:802.11ax(Full RU0); Bandwidth:40MHz; Channel:Low

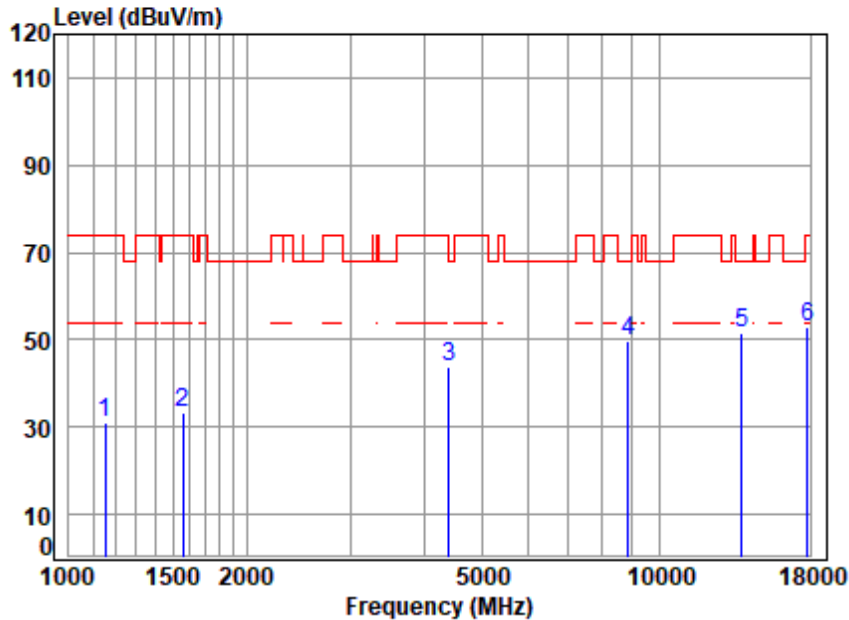

Site : chamber  
 Condition: 3m HORIZONTAL  
 Job No : 00384AT/00385AT  
 Mode : 6885 TX RSE  
 Note : 6E WIFI 11AX40

	Freq	Cable Loss	Ant Factor	Preamp Factor	Read Level	Limit Level	Over Limit	Remark
	MHz	dB	dB/m	dB	dBuV	dBuV/m	dBuV/m	dB
1	1152.148	3.49	23.92	38.33	41.82	30.90	74.00	-43.10 peak
2	1560.673	4.15	26.96	38.40	40.38	33.09	74.00	-40.91 peak
3	4405.090	7.06	34.74	35.79	37.75	43.76	68.20	-24.44 peak
4	8840.473	11.64	37.18	37.45	38.50	49.87	68.20	-18.33 peak
5	13770.000	13.74	39.24	37.22	35.95	51.71	68.20	-16.49 peak
6	17844.590	15.06	43.90	37.64	31.71	53.03	74.00	-20.97 peak



Unless otherwise agreed in writing, this document is issued by the Company subject to its General Conditions of Service printed overleaf, available on request or accessible at <https://www.sgs.com/en/Terms-and-Conditions>. Attention is drawn to the limitation of liability, indemnification and jurisdiction issues defined therein. Any holder of this document is advised that information contained hereon reflects the Company's findings at the time of its intervention only and within the limits of Client's instructions, if any. The Company's sole responsibility is to its Client and this document does not exonerate parties to a transaction from exercising all their rights and obligations under the transaction documents. This document cannot be reproduced except in full, without prior written approval of the Company. Any unauthorized alteration, forgery or falsification of the content or appearance of this document is unlawful and offenders may be prosecuted to the fullest extent of the law. Unless otherwise stated the results shown in this test report refer only to the sample(s) tested and such sample(s) are retained for 30 days only.

Attention: To check the authenticity of testing /inspection report & certificate, please contact us at telephone: (86-755) 8307 1443, or email: CN.Doccheck@sgs.com

No.1 Workshop, M-10, Middle Section, Science & Technology Park, Nanshan District, Shenzhen, Guangdong, China 518057 t (86-755) 26012053 f (86-755) 26710594 www.sgsgroup.com.cn  
 中国·广东·深圳市南山区科技园中区M-10栋1号厂房 邮编: 518057 t (86-755) 26012053 f (86-755) 26710594 sgs.china@sgs.com



Polarity: Vertical; Modulation:802.11ax(Full RU0); Bandwidth:40MHz; Channel:Low

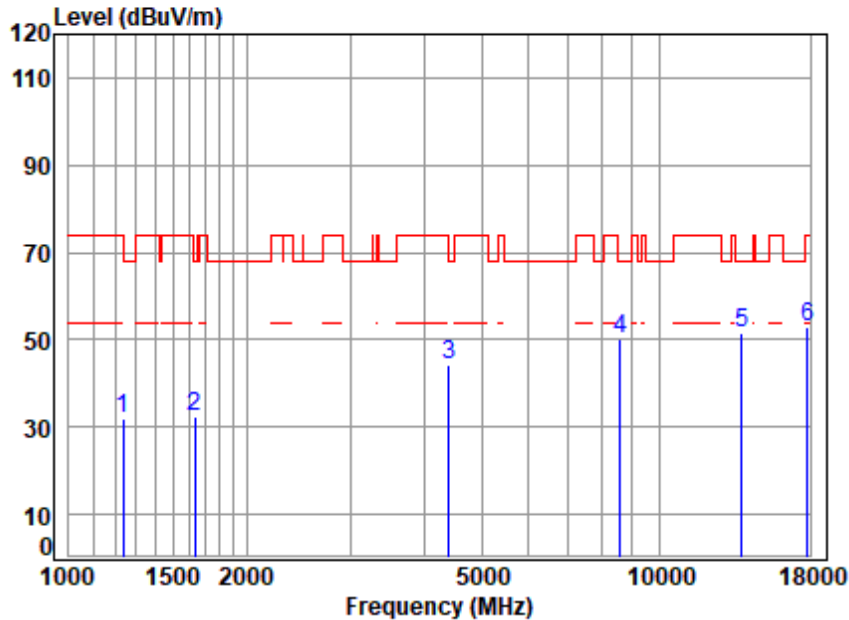

Site : chamber  
 Condition: 3m VERTICAL  
 Job No : 00384AT/00385AT  
 Mode : 6885 TX RSE  
 Note : 6E WIFI 11AX40

	Freq	Cable Loss	Ant Factor	Preamp Factor	Read Level	Limit Level	Over Limit	Remark
	MHz	dB	dB/m	dB	dBuV	dBuV/m	dBuV/m	dB
1	1238.483	3.65	24.94	38.35	41.74	31.98	74.00	-42.02 peak
2	1634.543	4.25	26.45	38.41	40.11	32.40	68.20	-35.80 peak
3	4405.090	7.06	34.74	35.79	38.33	44.34	68.20	-23.86 peak
4	8588.607	11.20	36.88	37.19	39.16	50.05	68.20	-18.15 peak
5	13770.000	13.74	39.24	37.22	35.87	51.63	68.20	-16.57 peak
6	17844.590	15.06	43.90	37.64	31.52	52.84	74.00	-21.16 peak



Unless otherwise agreed in writing, this document is issued by the Company subject to its General Conditions of Service printed overleaf, available on request or accessible at <https://www.sgs.com/en/Terms-and-Conditions>. Attention is drawn to the limitation of liability, indemnification and jurisdiction issues defined therein. Any holder of this document is advised that information contained hereon reflects the Company's findings at the time of its intervention only and within the limits of Client's instructions, if any. The Company's sole responsibility is to its Client and this document does not exonerate parties to a transaction from exercising all their rights and obligations under the transaction documents. This document cannot be reproduced except in full, without prior written approval of the Company. Any unauthorized alteration, forgery or falsification of the content or appearance of this document is unlawful and offenders may be prosecuted to the fullest extent of the law. Unless otherwise stated the results shown in this test report refer only to the sample(s) tested and such sample(s) are retained for 30 days only.

Attention: To check the authenticity of testing /inspection report & certificate, please contact us at telephone: (86-755) 8307 1443, or email: CN.Doccheck@sgs.com  
 No.1 Workshop, M-10, Middle Section, Science & Technology Park, Nanshan District, Shenzhen, Guangdong, China 518057 t (86-755) 26012053 f (86-755) 26710594 www.sgs.com.cn  
 中国·广东·深圳市南山区科技园中区M-10栋1号厂房 邮编: 518057 t (86-755) 26012053 f (86-755) 26710594 sgs.china@sgs.com

Polarity: Horizontal; Modulation:802.11ax(Full RU0); Bandwidth:40MHz; Channel:middle

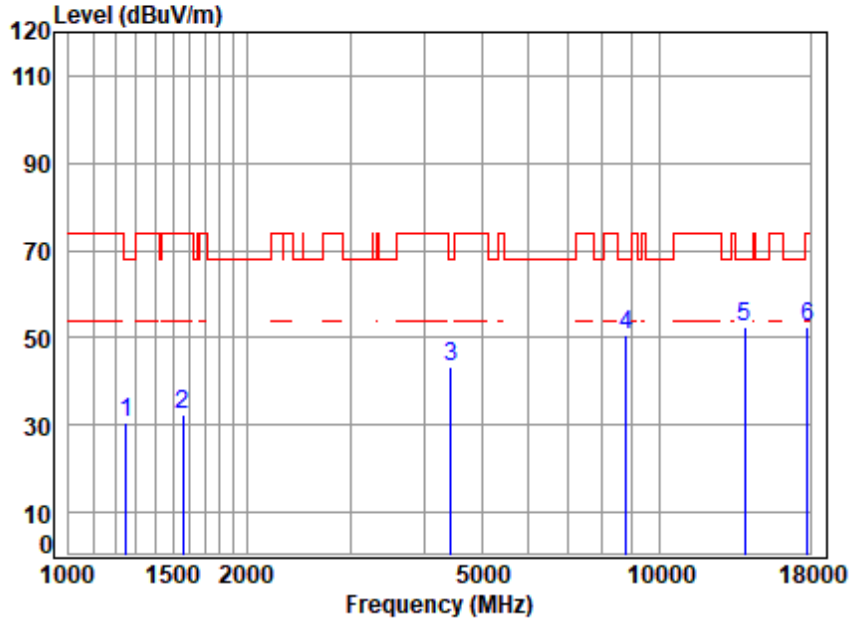

Site : chamber  
 Condition: 3m HORIZONTAL  
 Job No : 00384AT/00385AT  
 Mode : 6965 TX RSE  
 Note : 6E WIFI 11AX40

	Freq	Cable Loss	Ant Factor	Preamp Factor	Read Level	Limit Level	Over Limit	Remark
	MHz	dB	dB/m	dB	dBuV	dBuV/m	dBuV/m	dB
1	1252.885	3.67	25.08	38.35	40.33	30.73	68.20	-37.47 peak
2	1560.673	4.15	26.96	38.40	39.62	32.33	74.00	-41.67 peak
3	4430.628	7.08	34.43	35.77	37.61	43.35	68.20	-24.85 peak
4	8789.516	11.55	37.06	37.40	39.31	50.52	68.20	-17.68 peak
5	13930.000	13.77	39.56	37.21	36.21	52.33	68.20	-15.87 peak
6	17793.090	15.03	43.89	37.63	31.37	52.66	74.00	-21.34 peak



Unless otherwise agreed in writing, this document is issued by the Company subject to its General Conditions of Service printed overleaf, available on request or accessible at <https://www.sgs.com/en/Terms-and-Conditions>. Attention is drawn to the limitation of liability, indemnification and jurisdiction issues defined therein. Any holder of this document is advised that information contained hereon reflects the Company's findings at the time of its intervention only and within the limits of Client's instructions, if any. The Company's sole responsibility is to its Client and this document does not exonerate parties to a transaction from exercising all their rights and obligations under the transaction documents. This document cannot be reproduced except in full, without prior written approval of the Company. Any unauthorized alteration, forgery or falsification of the content or appearance of this document is unlawful and offenders may be prosecuted to the fullest extent of the law. Unless otherwise stated the results shown in this test report refer only to the sample(s) tested and such sample(s) are retained for 30 days only.

Attention: To check the authenticity of testing /inspection report & certificate, please contact us at telephone: (86-755) 8307 1443, or email: CN.Doccheck@sgs.com

No.1 Workshop, M-10, Middle Section, Science & Technology Park, Nanshan District, Shenzhen, Guangdong, China 518057 t (86-755) 26012053 f (86-755) 26710594 www.sgs.com.cn  
 中国·广东·深圳市南山区科技园中区M-10栋1号厂房 邮编: 518057 t (86-755) 26012053 f (86-755) 26710594 sgs.china@sgs.com

Polarity: Vertical; Modulation:802.11ax(Full RU0); Bandwidth:40MHz; Channel:middle

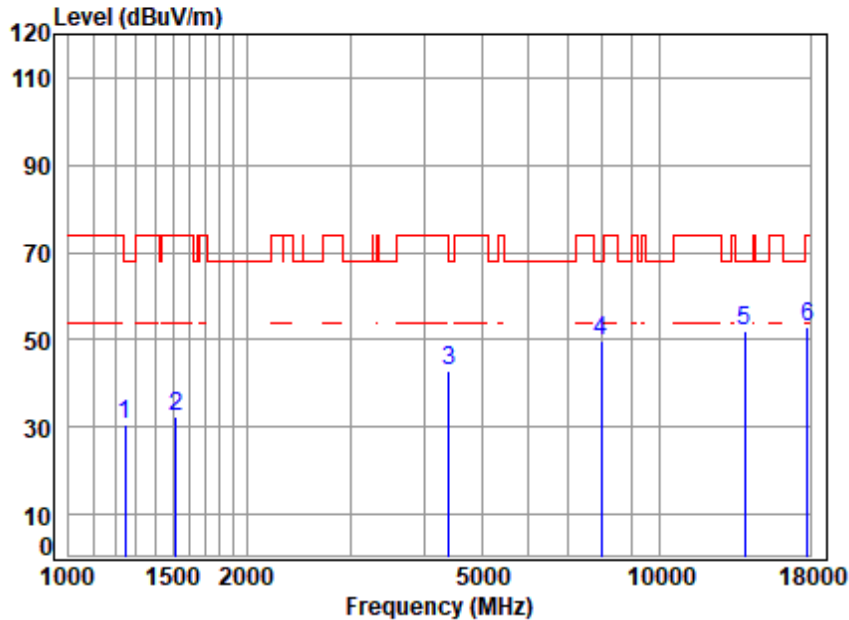

Site : chamber  
 Condition: 3m VERTICAL  
 Job No : 00384AT/00385AT  
 Mode : 6965 TX RSE  
 Note : 6E WIFI 11AX40

	Freq	Cable Loss	Ant Factor	Preamp Factor	Read Level	Limit Level	Over Limit	Remark
	MHz	dB	dB/m	dB	dBuV	dBuV/m	dBuV/m	dB
1	1245.663	3.66	25.04	38.35	40.40	30.75	68.20	-37.45 peak
2	1516.210	4.08	26.86	38.39	39.89	32.44	74.00	-41.56 peak
3	4405.090	7.06	34.74	35.79	36.93	42.94	68.20	-25.26 peak
4	7989.893	10.09	36.40	36.55	39.66	49.60	68.20	-18.60 peak
5	13930.000	13.77	39.56	37.21	36.03	52.15	68.20	-16.05 peak
6	17793.090	15.03	43.89	37.63	31.74	53.03	74.00	-20.97 peak



Unless otherwise agreed in writing, this document is issued by the Company subject to its General Conditions of Service printed overleaf, available on request or accessible at <https://www.sgs.com/en/Terms-and-Conditions>. Attention is drawn to the limitation of liability, indemnification and jurisdiction issues defined therein. Any holder of this document is advised that information contained hereon reflects the Company's findings at the time of its intervention only and within the limits of Client's instructions, if any. The Company's sole responsibility is to its Client and this document does not exonerate parties to a transaction from exercising all their rights and obligations under the transaction documents. This document cannot be reproduced except in full, without prior written approval of the Company. Any unauthorized alteration, forgery or falsification of the content or appearance of this document is unlawful and offenders may be prosecuted to the fullest extent of the law. Unless otherwise stated the results shown in this test report refer only to the sample(s) tested and such sample(s) are retained for 30 days only.

Attention: To check the authenticity of testing /inspection report & certificate, please contact us at telephone: (86-755) 8307 1443, or email: CN.Doccheck@sgs.com  
 No.1 Workshop, M-10, Middle Section, Science & Technology Park, Nanshan District, Shenzhen, Guangdong, China 518057 t (86-755) 26012053 f (86-755) 26710594 www.sgs.com.cn  
 中国·广东·深圳市南山区科技园中区M-10栋1号厂房 邮编: 518057 t (86-755) 26012053 f (86-755) 26710594 sgs.china@sgs.com



Polarity: Horizontal; Modulation:802.11ax(Full RU0); Bandwidth:40MHz; Channel:High

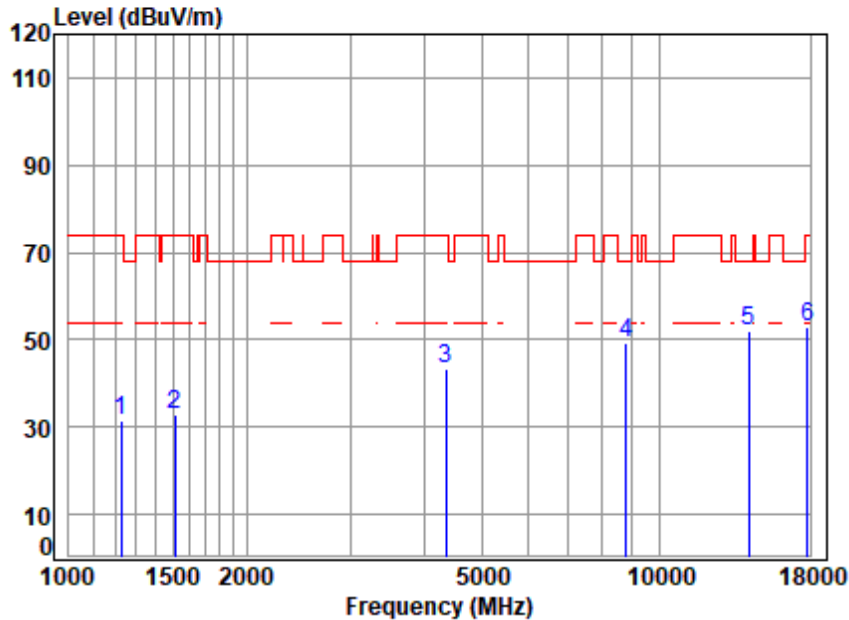

Site : chamber  
 Condition: 3m HORIZONTAL  
 Job No : 00384AT/00385AT  
 Mode : 7085 TX RSE  
 Note : 6E WIFI 11AX40

	Freq	Cable Loss	Ant Factor	Preamp Factor	Read Level	Limit Level	Over Limit	Remark
	MHz	dB	dB/m	dB	dBuV	dBuV/m	dBuV/m	dB
1	1227.791	3.63	24.79	38.34	41.45	74.00	-42.47	peak
2	1511.833	4.08	26.85	38.39	40.11	74.00	-41.35	peak
3	4354.454	7.03	34.44	35.83	37.52	74.00	-30.84	peak
4	8789.516	11.55	37.06	37.40	38.21	68.20	-18.78	peak
5	14170.000	13.84	39.80	37.18	35.51	68.20	-16.23	peak
6	17844.590	15.06	43.90	37.64	31.45	74.00	-21.23	peak



Unless otherwise agreed in writing, this document is issued by the Company subject to its General Conditions of Service printed overleaf, available on request or accessible at <https://www.sgs.com/en/Terms-and-Conditions>. Attention is drawn to the limitation of liability, indemnification and jurisdiction issues defined therein. Any holder of this document is advised that information contained hereon reflects the Company's findings at the time of its intervention only and within the limits of Client's instructions, if any. The Company's sole responsibility is to its Client and this document does not exonerate parties to a transaction from exercising all their rights and obligations under the transaction documents. This document cannot be reproduced except in full, without prior written approval of the Company. Any unauthorized alteration, forgery or falsification of the content or appearance of this document is unlawful and offenders may be prosecuted to the fullest extent of the law. Unless otherwise stated the results shown in this test report refer only to the sample(s) tested and such sample(s) are retained for 30 days only.  
 Attention: To check the authenticity of testing /inspection report & certificate, please contact us at telephone: (86-755) 8307 1443, or email: CN.Doccheck@sgs.com  
 No.1 Workshop, M-10, Middle Section, Science & Technology Park, Nanshan District, Shenzhen, Guangdong, China 518057 t (86-755) 26012053 f (86-755) 26710594 www.sgs.com.cn  
 中国·广东·深圳市南山区科技园中区M-10栋1号厂房 邮编: 518057 t (86-755) 26012053 f (86-755) 26710594 sgs.china@sgs.com

Polarity: Vertical; Modulation:802.11ax(Full RU0); Bandwidth:40MHz; Channel:High

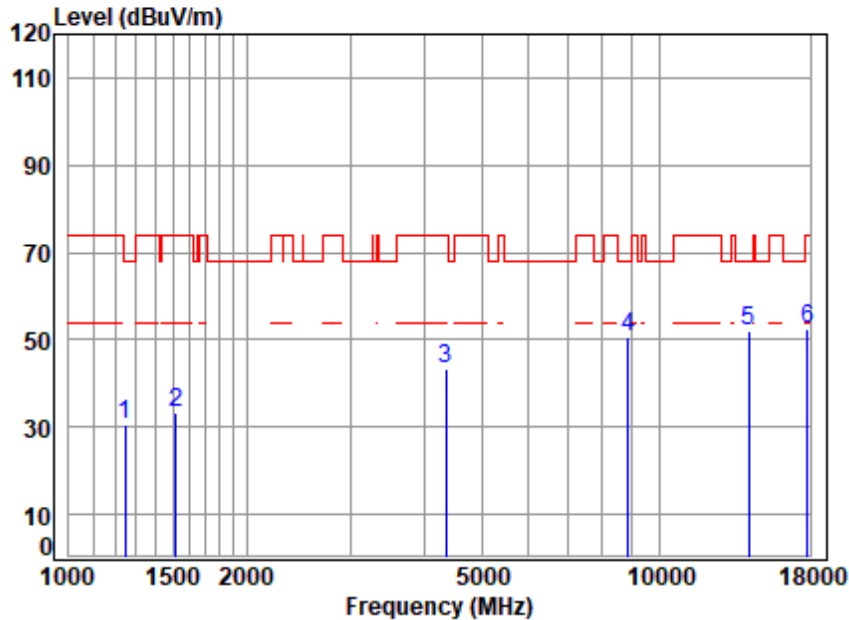

Site : chamber  
 Condition: 3m VERTICAL  
 Job No : 00384AT/00385AT  
 Mode : 7085 TX RSE  
 Note : 6E WIFI 11AX40

	Freq	Cable Loss	Ant Factor	Preamp Factor	Read Level	Limit Level	Over Line	Over Limit	Remark
	MHz	dB	dB/m	dB	dBuV	dBuV/m	dBuV/m	dB	
1	1245.663	3.66	25.04	38.35	40.42	30.77	68.20	-37.43	peak
2	1520.598	4.09	26.88	38.39	40.59	33.17	74.00	-40.83	peak
3	4354.454	7.03	34.44	35.83	37.75	43.39	74.00	-30.61	peak
4	8866.062	11.69	37.20	37.48	39.03	50.44	68.20	-17.76	peak
5	14170.000	13.84	39.80	37.18	35.77	52.23	68.20	-15.97	peak
6	17844.590	15.06	43.90	37.64	31.19	52.51	74.00	-21.49	peak



Unless otherwise agreed in writing, this document is issued by the Company subject to its General Conditions of Service printed overleaf, available on request or accessible at <https://www.sgs.com/en/Terms-and-Conditions>. Attention is drawn to the limitation of liability, indemnification and jurisdiction issues defined therein. Any holder of this document is advised that information contained hereon reflects the Company's findings at the time of its intervention only and within the limits of Client's instructions, if any. The Company's sole responsibility is to its Client and this document does not exonerate parties to a transaction from exercising all their rights and obligations under the transaction documents. This document cannot be reproduced except in full, without prior written approval of the Company. Any unauthorized alteration, forgery or falsification of the content or appearance of this document is unlawful and offenders may be prosecuted to the fullest extent of the law. Unless otherwise stated the results shown in this test report refer only to the sample(s) tested and such sample(s) are retained for 30 days only.

Attention: To check the authenticity of testing /inspection report & certificate, please contact us at telephone: (86-755) 8307 1443, or email: CN.Doccheck@sgs.com  
 No.1 Workshop, M-10, Middle Section, Science & Technology Park, Nanshan District, Shenzhen, Guangdong, China 518057 t (86-755) 26012053 f (86-755) 26710594 www.sgs.com.cn  
 中国·广东·深圳市南山区科技园中区M-10栋1号厂房 邮编: 518057 t (86-755) 26012053 f (86-755) 26710594 sgs.china@sgs.com

Polarity: Horizontal; Modulation:802.11ax(Full RU0); Bandwidth:80MHz; Channel:Low

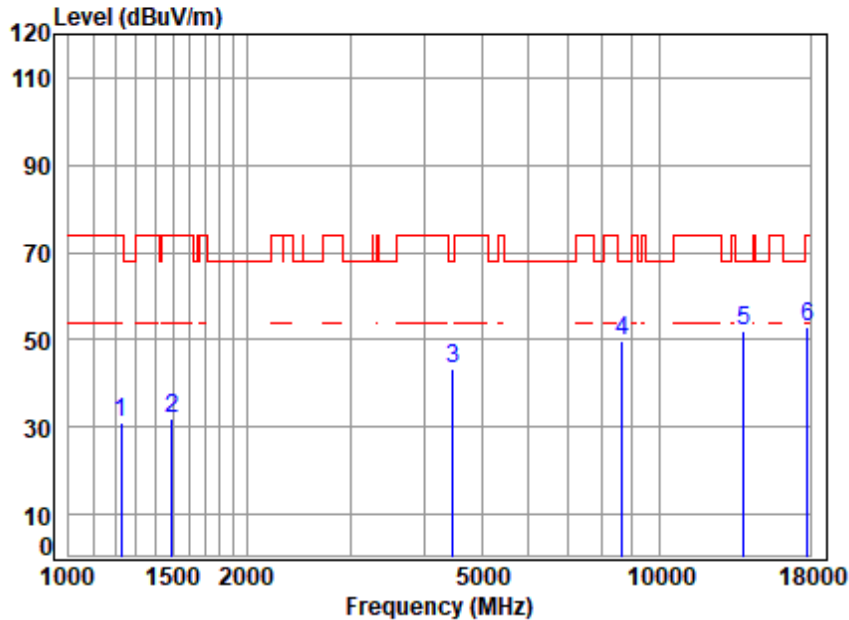

Site : chamber  
 Condition: 3m HORIZONTAL  
 Job No : 00384AT/00385AT  
 Mode : 6945 TX RSE  
 Note : 6E WIFI 11AX80

	Freq	Cable Loss	Ant Factor	Preamp Factor	Read Level	Limit Level	Over Line	Over Limit	Remark
	MHz	dB	dB/m	dB	dBuV	dBuV/m	dBuV/m	dB	
1	1227.791	3.63	24.79	38.34	41.03	31.11	74.00	-42.89	peak
2	1494.455	4.05	26.64	38.39	39.73	32.03	74.00	-41.97	peak
3	4469.214	7.10	33.97	35.75	37.96	43.28	68.20	-24.92	peak
4	8663.404	11.33	36.90	37.27	38.93	49.89	68.20	-18.31	peak
5	p13890.000	13.76	39.48	37.22	35.85	51.87	68.20	-16.33	peak
6	17844.590	15.06	43.90	37.64	31.56	52.88	74.00	-21.12	peak



Unless otherwise agreed in writing, this document is issued by the Company subject to its General Conditions of Service printed overleaf, available on request or accessible at <https://www.sgs.com/en/Terms-and-Conditions>. Attention is drawn to the limitation of liability, indemnification and jurisdiction issues defined therein. Any holder of this document is advised that information contained hereon reflects the Company's findings at the time of its intervention only and within the limits of Client's instructions, if any. The Company's sole responsibility is to its Client and this document does not exonerate parties to a transaction from exercising all their rights and obligations under the transaction documents. This document cannot be reproduced except in full, without prior written approval of the Company. Any unauthorized alteration, forgery or falsification of the content or appearance of this document is unlawful and offenders may be prosecuted to the fullest extent of the law. Unless otherwise stated the results shown in this test report refer only to the sample(s) tested and such sample(s) are retained for 30 days only.

Attention: To check the authenticity of testing /inspection report & certificate, please contact us at telephone: (86-755) 8307 1443, or email: CN.Doccheck@sgs.com

No.1 Workshop, M-10, Middle Section, Science & Technology Park, Nanshan District, Shenzhen, Guangdong, China 518057 t (86-755) 26012053 f (86-755) 26710594 www.sgs.com.cn  
 中国·广东·深圳市南山区科技园中区M-10栋1号厂房 邮编: 518057 t (86-755) 26012053 f (86-755) 26710594 sgs.china@sgs.com



Polarity: Vertical; Modulation:802.11ax(Full RU0); Bandwidth:80MHz; Channel:Low

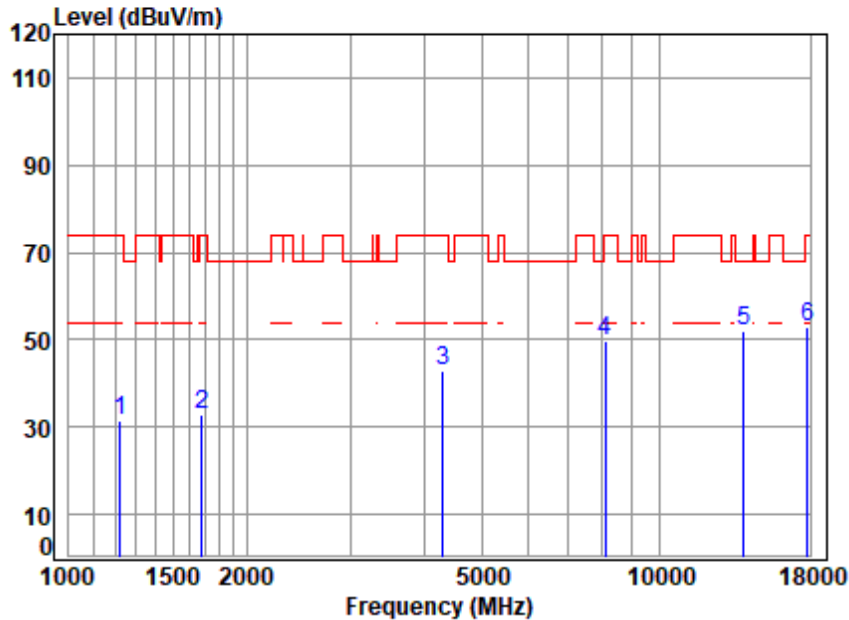

Site : chamber  
 Condition: 3m VERTICAL  
 Job No : 00384AT/00385AT  
 Mode : 6945 TX RSE  
 Note : 6E WIFI 11AX80

	Freq	Cable Loss	Ant Factor	Preamp Factor	Read Level	Limit Level	Over Line	Over Limit	Remark
	MHz	dB	dB/m	dB	dBuV	dBuV/m	dBuV/m	dB	
1	1220.714	3.62	24.69	38.34	41.52	31.49	74.00	-42.51	peak
2	1682.477	4.31	26.24	38.41	40.62	32.76	74.00	-41.24	peak
3	4304.400	6.99	34.04	35.87	37.85	43.01	74.00	-30.99	peak
4	8106.200	10.30	36.50	36.68	39.72	49.84	74.00	-24.16	peak
5	13890.000	13.76	39.48	37.22	36.12	52.14	68.20	-16.06	peak
6	17793.090	15.03	43.89	37.63	31.73	53.02	74.00	-20.98	peak



Unless otherwise agreed in writing, this document is issued by the Company subject to its General Conditions of Service printed overleaf, available on request or accessible at <https://www.sgs.com/en/Terms-and-Conditions>. Attention is drawn to the limitation of liability, indemnification and jurisdiction issues defined therein. Any holder of this document is advised that information contained hereon reflects the Company's findings at the time of its intervention only and within the limits of Client's instructions, if any. The Company's sole responsibility is to its Client and this document does not exonerate parties to a transaction from exercising all their rights and obligations under the transaction documents. This document cannot be reproduced except in full, without prior written approval of the Company. Any unauthorized alteration, forgery or falsification of the content or appearance of this document is unlawful and offenders may be prosecuted to the fullest extent of the law. Unless otherwise stated the results shown in this test report refer only to the sample(s) tested and such sample(s) are retained for 30 days only.

Attention: To check the authenticity of testing /inspection report & certificate, please contact us at telephone: (86-755) 8307 1443, or email: CN.Doccheck@sgs.com  
 No.1 Workshop, M-10, Middle Section, Science & Technology Park, Nanshan District, Shenzhen, Guangdong, China 518057 t (86-755) 26012053 f (86-755) 26710594 www.sgs.com.cn  
 中国·广东·深圳市南山区科技园中区M-10栋1号厂房 邮编: 518057 t (86-755) 26012053 f (86-755) 26710594 sgs.china@sgs.com

Polarity: Horizontal; Modulation:802.11ax(Full RU0); Bandwidth:80MHz; Channel:High

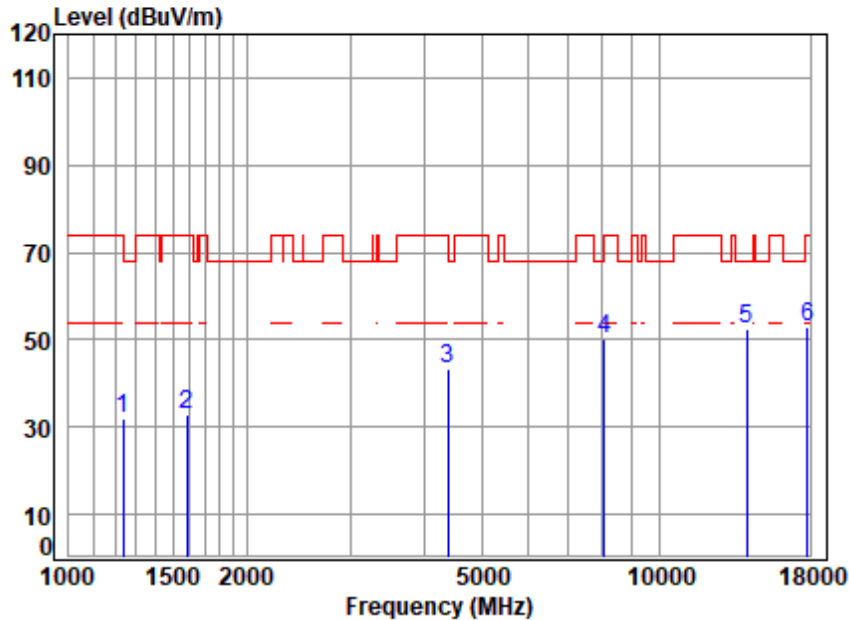

Site : chamber  
 Condition: 3m HORIZONTAL  
 Job No : 00384AT/00385AT  
 Mode : 7025 TX RSE  
 Note : 6E WIFI 11AX80

	Freq	Cable Loss	Ant Factor	Preamp Factor	Read Level	Limit Level	Over Line	Over Limit	Remark
	MHz	dB	dB/m	dB	dBuV	dBuV/m	dBuV/m	dB	
1	1238.483	3.65	24.94	38.35	41.70	31.94	74.00	-42.06	peak
2	1583.392	4.18	26.87	38.40	40.25	32.90	74.00	-41.10	peak
3	4379.699	7.04	34.64	35.81	37.46	43.33	74.00	-30.67	peak
4	8059.475	10.21	36.42	36.63	40.29	50.29	74.00	-23.71	peak
5	14050.000	13.80	39.75	37.20	35.98	52.33	68.20	-15.87	peak
6	17844.590	15.06	43.90	37.64	31.53	52.85	74.00	-21.15	peak



Unless otherwise agreed in writing, this document is issued by the Company subject to its General Conditions of Service printed overleaf, available on request or accessible at <https://www.sgs.com/en/Terms-and-Conditions>. Attention is drawn to the limitation of liability, indemnification and jurisdiction issues defined therein. Any holder of this document is advised that information contained hereon reflects the Company's findings at the time of its intervention only and within the limits of Client's instructions, if any. The Company's sole responsibility is to its Client and this document does not exonerate parties to a transaction from exercising all their rights and obligations under the transaction documents. This document cannot be reproduced except in full, without prior written approval of the Company. Any unauthorized alteration, forgery or falsification of the content or appearance of this document is unlawful and offenders may be prosecuted to the fullest extent of the law. Unless otherwise stated the results shown in this test report refer only to the sample(s) tested and such sample(s) are retained for 30 days only.

Attention: To check the authenticity of testing /inspection report & certificate, please contact us at telephone: (86-755) 8307 1443, or email: CN.Doccheck@sgs.com

No.1 Workshop, M-10, Middle Section, Science & Technology Park, Nanshan District, Shenzhen, Guangdong, China 518057 t (86-755) 26012053 f (86-755) 26710594 www.sgs.com.cn  
 中国·广东·深圳市南山区科技园中区M-10栋1号厂房 邮编: 518057 t (86-755) 26012053 f (86-755) 26710594 sgs.china@sgs.com

Polarity: Vertical; Modulation:802.11ax(Full RU0); Bandwidth:80MHz; Channel:High

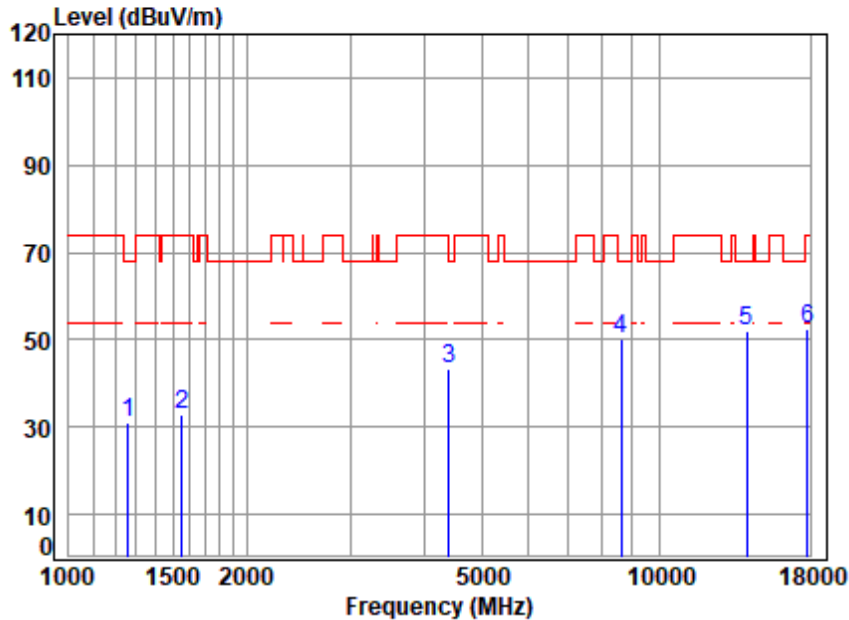

Site : chamber  
 Condition: 3m VERTICAL  
 Job No : 00384AT/00385AT  
 Mode : 7025 TX RSE  
 Note : 6E WIFI 11AX80

	Freq	Cable Loss	Ant Factor	Preamp Factor	Read Level	Limit Level	Over Limit	Remark
	MHz	dB	dB/m	dB	dBuV	dBuV/m	dBuV/m	dB
1	1260.149	3.69	25.04	38.35	40.51	30.89	68.20	-37.31 peak
2	1556.169	4.14	26.98	38.40	40.04	32.76	74.00	-41.24 peak
3	4405.090	7.06	34.74	35.79	37.35	43.36	68.20	-24.84 peak
4	8613.468	11.24	36.90	37.22	39.33	50.25	68.20	-17.95 peak
5	14050.000	13.80	39.75	37.20	35.49	51.84	68.20	-16.36 peak
6	17793.090	15.03	43.89	37.63	31.40	52.69	74.00	-21.31 peak



Unless otherwise agreed in writing, this document is issued by the Company subject to its General Conditions of Service printed overleaf, available on request or accessible at <https://www.sgs.com/en/Terms-and-Conditions>. Attention is drawn to the limitation of liability, indemnification and jurisdiction issues defined therein. Any holder of this document is advised that information contained hereon reflects the Company's findings at the time of its intervention only and within the limits of Client's instructions, if any. The Company's sole responsibility is to its Client and this document does not exonerate parties to a transaction from exercising all their rights and obligations under the transaction documents. This document cannot be reproduced except in full, without prior written approval of the Company. Any unauthorized alteration, forgery or falsification of the content or appearance of this document is unlawful and offenders may be prosecuted to the fullest extent of the law. Unless otherwise stated the results shown in this test report refer only to the sample(s) tested and such sample(s) are retained for 30 days only.

Attention: To check the authenticity of testing /inspection report & certificate, please contact us at telephone: (86-755) 8307 1443, or email: CN.Doccheck@sgs.com  
 No.1 Workshop, M-10, Middle Section, Science & Technology Park, Nanshan District, Shenzhen, Guangdong, China 518057 t (86-755) 26012053 f (86-755) 26710594 www.sgs.com.cn  
 中国·广东·深圳市南山区科技园中区M-10栋1号厂房 邮编: 518057 t (86-755) 26012053 f (86-755) 26710594 sgs.china@sgs.com



Polarity: Horizontal; Modulation:802.11ax(Full RU0); Bandwidth:160MHz; Channel:middle

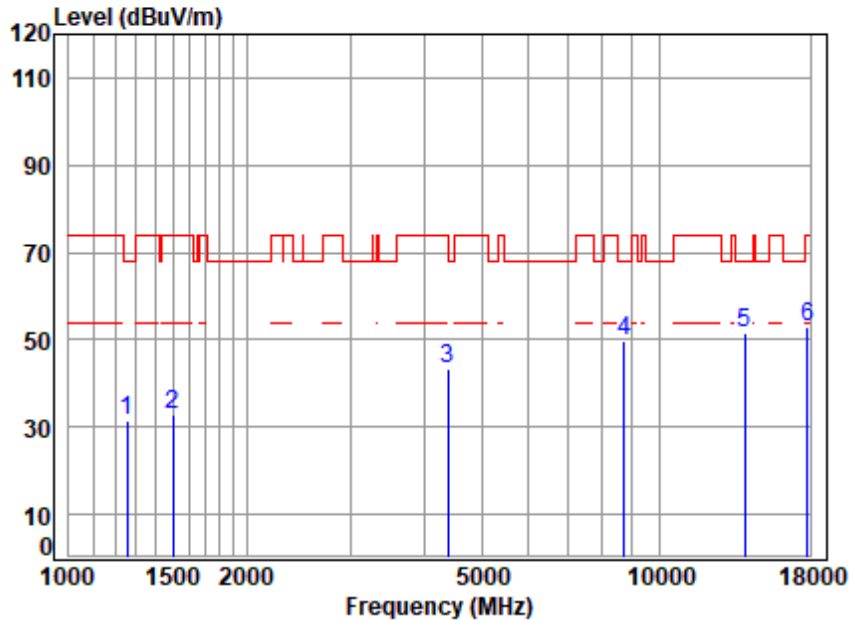

Site : chamber  
 Condition: 3m HORIZONTAL  
 Job No : 00384AT/00385AT  
 Mode : 6985 TX RSE  
 Note : 6E WIFI 11AX160

	Freq	Cable Loss	Ant Factor	Preamp Factor	Read Level	Limit Level	Over Line	Over Limit	Remark
	MHz	dB	dB/m	dB	dBuV	dBuV/m	dBuV/m	dB	
1	1256.512	3.68	25.06	38.35	41.26	31.65	68.20	-36.55	peak
2	1503.119	4.07	26.81	38.39	40.15	32.64	74.00	-41.36	peak
3	4379.699	7.04	34.64	35.81	37.37	43.24	74.00	-30.76	peak
4	8713.630	11.42	36.90	37.32	38.66	49.66	68.20	-18.54	peak
5	13970.000	13.78	39.64	37.21	35.44	51.65	68.20	-16.55	peak
6	17844.590	15.06	43.90	37.64	31.56	52.88	74.00	-21.12	peak



Unless otherwise agreed in writing, this document is issued by the Company subject to its General Conditions of Service printed overleaf, available on request or accessible at <https://www.sgs.com/en/Terms-and-Conditions>. Attention is drawn to the limitation of liability, indemnification and jurisdiction issues defined therein. Any holder of this document is advised that information contained hereon reflects the Company's findings at the time of its intervention only and within the limits of Client's instructions, if any. The Company's sole responsibility is to its Client and this document does not exonerate parties to a transaction from exercising all their rights and obligations under the transaction documents. This document cannot be reproduced except in full, without prior written approval of the Company. Any unauthorized alteration, forgery or falsification of the content or appearance of this document is unlawful and offenders may be prosecuted to the fullest extent of the law. Unless otherwise stated the results shown in this test report refer only to the sample(s) tested and such sample(s) are retained for 30 days only.

Attention: To check the authenticity of testing /inspection report & certificate, please contact us at telephone: (86-755) 8307 1443, or email: CN.Doccheck@sgs.com  
 No.1 Workshop, M-10, Middle Section, Science & Technology Park, Nanshan District, Shenzhen, Guangdong, China 518057 t (86-755) 26012053 f (86-755) 26710594 www.sgs.com.cn  
 中国·广东·深圳市南山区科技园中区M-10栋1号厂房 邮编: 518057 t (86-755) 26012053 f (86-755) 26710594 sgs.china@sgs.com

Polarity: Vertical; Modulation:802.11ax(Full RU0); Bandwidth:160MHz; Channel:middle

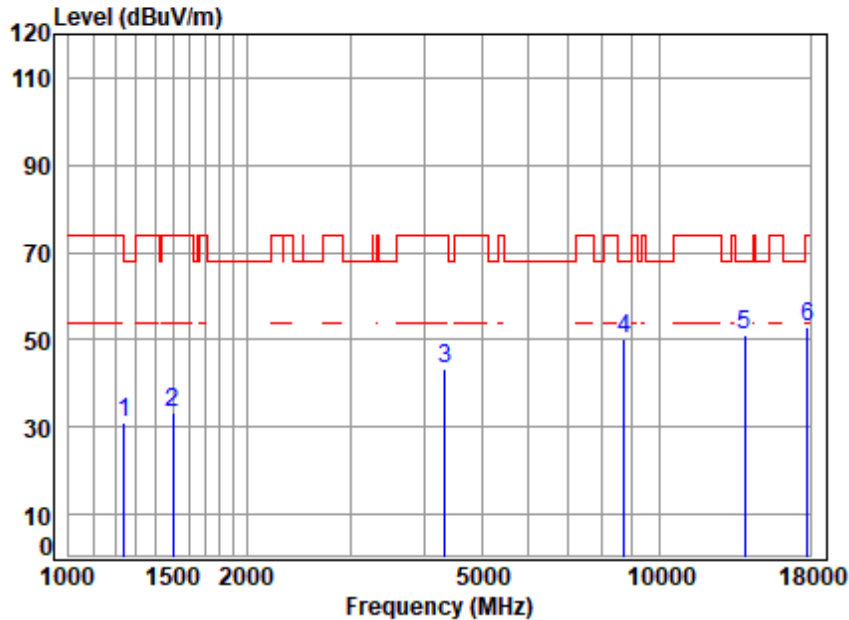

Site : chamber  
 Condition: 3m VERTICAL  
 Job No : 00384AT/00385AT  
 Mode : 6985 TX RSE  
 Note : 6E WIFI 11AX160

	Freq	Cable Loss	Ant Factor	Preamp Factor	Read Level	Limit Level	Over Line	Over Limit	Remark
	MHz	dB	dB/m	dB	dBuV	dBuV/m	dBuV/m	dB	
1	1242.068	3.66	24.99	38.35	40.71	31.01	68.20	-37.19	peak
2	1503.119	4.07	26.81	38.39	40.71	33.20	74.00	-40.80	peak
3	4329.354	7.01	34.23	35.85	38.00	43.39	74.00	-30.61	peak
4	8713.630	11.42	36.90	37.32	39.23	50.23	68.20	-17.97	peak
5	13970.000	13.78	39.64	37.21	34.99	51.20	68.20	-17.00	peak
6	17844.590	15.06	43.90	37.64	31.64	52.96	74.00	-21.04	peak



Unless otherwise agreed in writing, this document is issued by the Company subject to its General Conditions of Service printed overleaf, available on request or accessible at <https://www.sgs.com/en/Terms-and-Conditions>. Attention is drawn to the limitation of liability, indemnification and jurisdiction issues defined therein. Any holder of this document is advised that information contained hereon reflects the Company's findings at the time of its intervention only and within the limits of Client's instructions, if any. The Company's sole responsibility is to its Client and this document does not exonerate parties to a transaction from exercising all their rights and obligations under the transaction documents. This document cannot be reproduced except in full, without prior written approval of the Company. Any unauthorized alteration, forgery or falsification of the content or appearance of this document is unlawful and offenders may be prosecuted to the fullest extent of the law. Unless otherwise stated the results shown in this test report refer only to the sample(s) tested and such sample(s) are retained for 30 days only.

Attention: To check the authenticity of testing /inspection report & certificate, please contact us at telephone: (86-755) 8307 1443, or email: CN.Doccheck@sgs.com  
 No.1 Workshop, M-10, Middle Section, Science & Technology Park, Nanshan District, Shenzhen, Guangdong, China 518057 t (86-755) 26012053 f (86-755) 26710594 www.sgs.com.cn  
 中国·广东·深圳市南山区科技园中区M-10栋1号厂房 邮编: 518057 t (86-755) 26012053 f (86-755) 26710594 sgs.china@sgs.com

**7.10 Radiated Emissions which fall in the restricted bands**

Test Requirement 47 CFR Part 15, Subpart C 15.209 & Subpart E 15.407(b)  
 Test Method: KDB 789033 D02 II G  
 Measurement Distance: 3m

Limit:

Frequency(MHz)	Field strength(microvolts/meter)	Measurement distance(meters)
0.009-0.490	2400/F(kHz)	300
0.490-1.705	24000/F(kHz)	30
1.705-30.0	30	30
30-88	100	3
88-216	150	3
216-960	200	3
Above 960	500	3

\*(1) For transmitters operating in the 5.15-5.25 GHz band: All emissions outside of the 5.15-5.35 GHz band shall not exceed an e.i.r.p. of -27 dBm/MHz.

(2) For transmitters operating in the 5.25-5.35 GHz band: All emissions outside of the 5.15-5.35 GHz band shall not exceed an e.i.r.p. of -27 dBm/MHz.

(3) For transmitters operating in the 5.47-5.725 GHz band: All emissions outside of the 5.47-5.725 GHz band shall not exceed an e.i.r.p. of -27 dBm/MHz.

(4) For transmitters operating in the 5.725-5.85 GHz band:

(i) All emissions shall be limited to a level of -27 dBm/MHz at 75 MHz or more above or below the band edge increasing linearly to 10 dBm/MHz at 25 MHz above or below the band edge, and from 25 MHz above or below the band edge increasing linearly to a level of 15.6 dBm/MHz at 5 MHz above or below the band edge, and from 5 MHz above or below the band edge increasing linearly to a level of 27 dBm/MHz at the band edge.

Remark: The emission limits shown in the above table are based on measurements employing a CISPR quasi-peak detector except for the frequency bands 9-90kHz, 110-490kHz and above 1000 MHz. Radiated emission limits in these three bands are based on measurements employing an average detector, the peak field strength of any emission shall not exceed the maximum permitted average limits specified above by more than 20 dB under any condition of modulation.



Unless otherwise agreed in writing, this document is issued by the Company subject to its General Conditions of Service printed overleaf, available on request or accessible at <https://www.sgs.com/en/Terms-and-Conditions>. Attention is drawn to the limitation of liability, indemnification and jurisdiction issues defined therein. Any holder of this document is advised that information contained hereon reflects the Company's findings at the time of its intervention only and within the limits of Client's instructions, if any. The Company's sole responsibility is to its Client and this document does not exonerate parties to a transaction from exercising all their rights and obligations under the transaction documents. This document cannot be reproduced except in full, without prior written approval of the Company. Any unauthorized alteration, forgery or falsification of the content or appearance of this document is unlawful and offenders may be prosecuted to the fullest extent of the law. Unless otherwise stated the results shown in this test report refer only to the sample(s) tested and such sample(s) are retained for 30 days only.

Attention: To check the authenticity of testing /inspection report & certificate, please contact us at telephone: (86-755) 8307 1443, or email: CN.Doccheck@sgs.com  
 No.1 Workshop, M-10, Middle Section, Science & Technology Park, Nanshan District, Shenzhen, Guangdong, China 518057 t (86-755) 26012053 f (86-755) 26710594 www.sgs.com.cn  
 中国·广东·深圳市南山区科技园中区M-10栋1号厂房 邮编: 518057 t (86-755) 26012053 f (86-755) 26710594 sgs.china@sgs.com



**7.10.1 E.U.T. Operation**

Operating Environment:

Temperature: 18.8 °C Humidity: 31.0 % RH Atmospheric Pressure: 1000 mbar

**7.10.2 Test Mode Description**

Pre-scan / Final test	Mode Code	Description
Final test	01	TX mode (U-NII-5) _ Keep the EUT in continuously transmitting mode with all modulation types. All data rates for each modulation type have been tested and found the data rate @ MCS0 is the worst case of IEEE 802.11a/ax 20/40/80/160, Only the data of worst case is recorded in the report.
Final test	02	TX mode (U-NII-6) _ Keep the EUT in continuously transmitting mode with all modulation types. All data rates for each modulation type have been tested and found the data rate @ MCS0 is the worst case of IEEE 802.11a/ax 20/40/80/160, Only the data of worst case is recorded in the report.
Final test	03	TX mode (U-NII-7) _ Keep the EUT in continuously transmitting mode with all modulation types. All data rates for each modulation type have been tested and found the data rate @ MCS0 is the worst case of IEEE 802.11a/ax 20/40/80/160, Only the data of worst case is recorded in the report.
Final test	04	TX mode (U-NII-8) _ Keep the EUT in continuously transmitting mode with all modulation types. All data rates for each modulation type have been tested and found the data rate @ MCS0 is the worst case of IEEE 802.11a/ax 20/40/80/160, Only the data of worst case is recorded in the report.

**7.10.3 Test Setup Diagram**

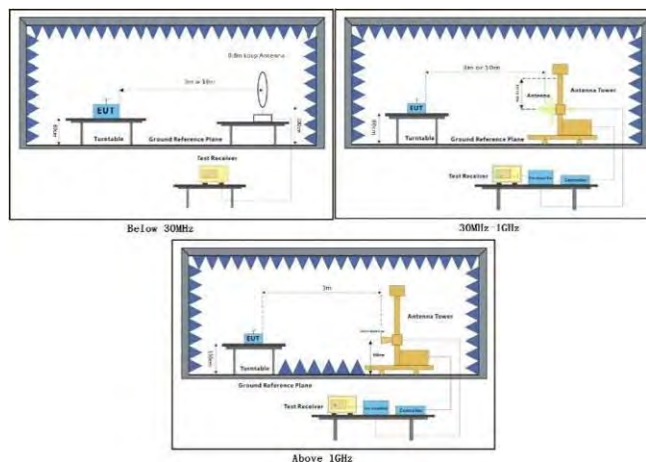

Unless otherwise agreed in writing, this document is issued by the Company subject to its General Conditions of Service printed overleaf, available on request or accessible at <https://www.sgs.com/en/Terms-and-Conditions>. Attention is drawn to the limitation of liability, indemnification and jurisdiction issues defined therein. Any holder of this document is advised that information contained hereon reflects the Company's findings at the time of its intervention only and within the limits of Client's instructions, if any. The Company's sole responsibility is to its Client and this document does not exonerate parties to a transaction from exercising all their rights and obligations under the transaction documents. This document cannot be reproduced except in full, without prior written approval of the Company. Any unauthorized alteration, forgery or falsification of the content or appearance of this document is unlawful and offenders may be prosecuted to the fullest extent of the law. Unless otherwise stated the results shown in this test report refer only to the sample(s) tested and such sample(s) are retained for 30 days only.

Attention: To check the authenticity of testing /inspection report & certificate, please contact us at telephone: (86-755) 8307 1443, or email: CN.Doccheck@sgs.com  
 No.1 Workshop, M-10, Middle Section, Science & Technology Park, Nanshan District, Shenzhen, Guangdong, China 518057 t (86-755) 26012053 f (86-755) 26710594 www.sgs.com.cn  
 中国·广东·深圳市南山区科技园中区M-10栋1号厂房 邮编: 518057 t (86-755) 26012053 f (86-755) 26710594 sgs.china@sgs.com



**7.10.4 Measurement Procedure and Data**

- a. For below 1GHz, the EUT was placed on the top of a rotating table 0.8 meters above the ground at a 3 or 10 meter semi-anechoic chamber. The table was rotated 360 degrees to determine the position of the highest radiation.
- b. For above 1GHz, the EUT was placed on the top of a rotating table 1.5 meters above the ground at a 3 meter fully-anechoic chamber. The table was rotated 360 degrees to determine the position of the highest radiation.
- c. The EUT was set 3 or 10 meters away from the interference-receiving antenna, which was mounted on the top of a variable-height antenna tower.
- d. The antenna height is varied from one meter to four meters above the ground to determine the maximum value of the field strength. Both horizontal and vertical polarizations of the antenna are set to make the measurement.
- e. For each suspected emission, the EUT was arranged to its worst case and then the antenna was tuned to heights from 1 meter to 4 meters (for the test frequency of below 30MHz, the antenna was tuned to heights 1 meter) and the rotatable table was turned from 0 degrees to 360 degrees to find the maximum reading.
- f. The test-receiver system was set to Peak Detect Function and Specified Bandwidth with Maximum Hold Mode.
- g. If the emission level of the EUT in peak mode was 10dB lower than the limit specified, then testing could be stopped and the peak values of the EUT would be reported. Otherwise the emissions that did not have 10dB margin would be re-tested one by one using peak, quasi-peak or average method as specified and then reported in a data sheet.
- h. Test the EUT in the lowest channel, the middle channel, the Highest channel.
- i. The radiation measurements are performed in X, Y, Z axis positioning for Transmitting mode, and found the X axis positioning which it is the worst case.
- j. Repeat above procedures until all frequencies measured was complete.

Remark: Level= Read Level+ Cable Loss+ Antenna Factor- Preamp Factor



Unless otherwise agreed in writing, this document is issued by the Company subject to its General Conditions of Service printed overleaf, available on request or accessible at <https://www.sgs.com/en/Terms-and-Conditions>. Attention is drawn to the limitation of liability, indemnification and jurisdiction issues defined therein. Any holder of this document is advised that information contained hereon reflects the Company's findings at the time of its intervention only and within the limits of Client's instructions, if any. The Company's sole responsibility is to its Client and this document does not exonerate parties to a transaction from exercising all their rights and obligations under the transaction documents. This document cannot be reproduced except in full, without prior written approval of the Company. Any unauthorized alteration, forgery or falsification of the content or appearance of this document is unlawful and offenders may be prosecuted to the fullest extent of the law. Unless otherwise stated the results shown in this test report refer only to the sample(s) tested and such sample(s) are retained for 30 days only.

Attention: To check the authenticity of testing /inspection report & certificate, please contact us at telephone: (86-755) 8307 1443, or email: CN.Doccheck@sgs.com  
 No.1 Workshop, M-10, Middle Section, Science & Technology Park, Nanshan District, Shenzhen, Guangdong, China 518057 t (86-755) 26012053 f (86-755) 26710594 www.sgs.com.cn  
 中国·广东·深圳市南山区科技园中区M-10栋1号厂房 邮编: 518057 t (86-755) 26012053 f (86-755) 26710594 sgs.china@sgs.com

Polarity: Horizontal; Modulation:802.11ax(Full RU0); Bandwidth:20MHz; Channel:Low

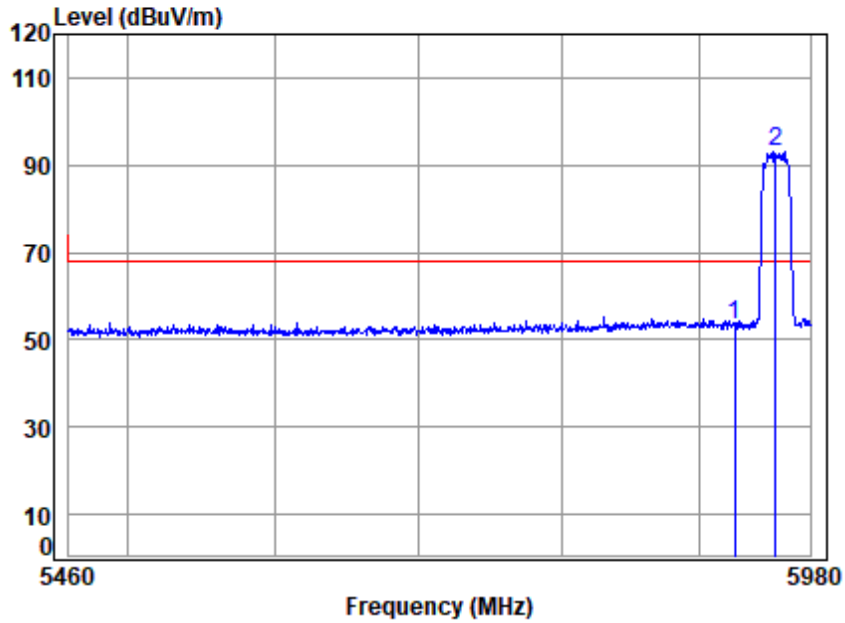

Site : chamber  
 Condition: 3m HORIZONTAL  
 Job No : 00384AT/00385AT  
 Mode : 5955 Band edge  
 : 5G WIFI 11AX20

	Cable	Ant	Preamp	Read	Limit	Over	
Freq	Loss	Factor	Factor	Level	Level	Line	Limit Remark
MHz	dB	dB/m	dB	dBuV	dBuV/m	dBuV/m	dB
1	8.12	34.65	34.93	45.62	53.46	68.20	-14.74 peak
2 p	8.14	34.72	34.92	85.21	93.15	68.20	24.95 peak



Unless otherwise agreed in writing, this document is issued by the Company subject to its General Conditions of Service printed overleaf, available on request or accessible at <https://www.sgs.com/en/Terms-and-Conditions>. Attention is drawn to the limitation of liability, indemnification and jurisdiction issues defined therein. Any holder of this document is advised that information contained hereon reflects the Company's findings at the time of its intervention only and within the limits of Client's instructions, if any. The Company's sole responsibility is to its Client and this document does not exonerate parties to a transaction from exercising all their rights and obligations under the transaction documents. This document cannot be reproduced except in full, without prior written approval of the Company. Any unauthorized alteration, forgery or falsification of the content or appearance of this document is unlawful and offenders may be prosecuted to the fullest extent of the law. Unless otherwise stated the results shown in this test report refer only to the sample(s) tested and such sample(s) are retained for 30 days only.

Attention: To check the authenticity of testing /inspection report & certificate, please contact us at telephone: (86-755) 8307 1443, or email: CN.Doccheck@sgs.com  
 No.1 Workshop, M-10, Middle Section, Science & Technology Park, Nanshan District, Shenzhen, Guangdong, China 518057 t (86-755) 26012053 f (86-755) 26710594 www.sgsgroup.com.cn  
 中国·广东·深圳市南山区科技园中区M-10栋1号厂房 邮编: 518057 t (86-755) 26012053 f (86-755) 26710594 sgs.china@sgs.com



Polarity: Vertical; Modulation:802.11ax(Full RU0); Bandwidth:20MHz; Channel:Low

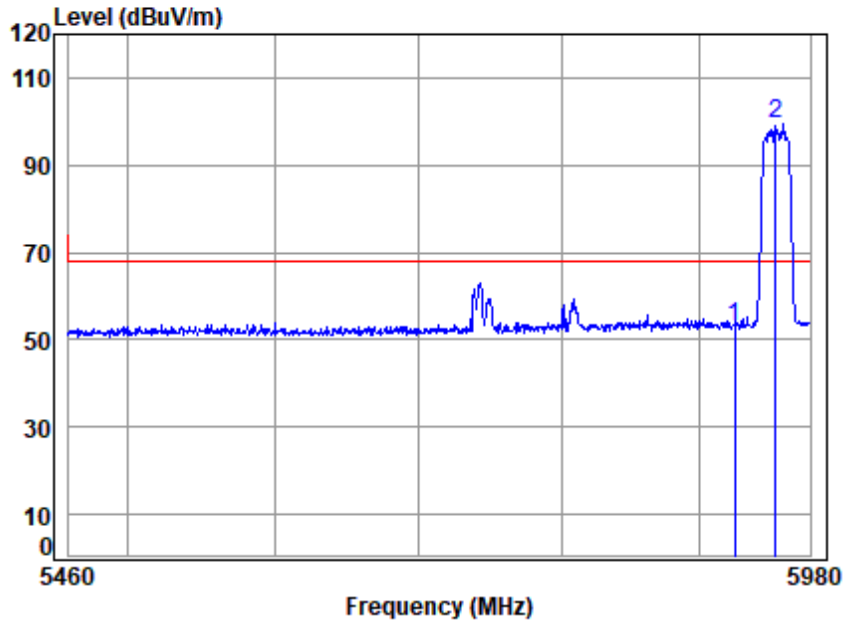

Site : chamber  
 Condition: 3m VERTICAL  
 Job No : 00384AT/00385AT  
 Mode : 5955 Band edge  
 : 5G WIFI 11AX20

	Cable	Ant	Preamp	Read	Limit	Over	
Freq	Loss	Factor	Factor	Level	Level	Line	Limit Remark
MHz	dB	dB/m	dB	dBuV	dBuV/m	dBuV/m	dB
1	5925.000	8.12	34.65	34.93	44.95	52.79	68.20 -15.41 peak
2 p	5955.000	8.14	34.72	34.92	91.70	99.64	68.20 31.44 peak



Unless otherwise agreed in writing, this document is issued by the Company subject to its General Conditions of Service printed overleaf, available on request or accessible at <https://www.sgs.com/en/Terms-and-Conditions>. Attention is drawn to the limitation of liability, indemnification and jurisdiction issues defined therein. Any holder of this document is advised that information contained hereon reflects the Company's findings at the time of its intervention only and within the limits of Client's instructions, if any. The Company's sole responsibility is to its Client and this document does not exonerate parties to a transaction from exercising all their rights and obligations under the transaction documents. This document cannot be reproduced except in full, without prior written approval of the Company. Any unauthorized alteration, forgery or falsification of the content or appearance of this document is unlawful and offenders may be prosecuted to the fullest extent of the law. Unless otherwise stated the results shown in this test report refer only to the sample(s) tested and such sample(s) are retained for 30 days only.

Attention: To check the authenticity of testing /inspection report & certificate, please contact us at telephone: (86-755) 8307 1443, or email: CN.Doccheck@sgs.com  
 No.1 Workshop, M-10, Middle Section, Science & Technology Park, Nanshan District, Shenzhen, Guangdong, China 518057 t (86-755) 26012053 f (86-755) 26710594 www.sgs.com.cn  
 中国·广东·深圳市南山区科技园中区M-10栋1号厂房 邮编: 518057 t (86-755) 26012053 f (86-755) 26710594 sgs.china@sgs.com

Polarity: Horizontal; Modulation:802.11ax(Full RU0); Bandwidth:20MHz; Channel:High

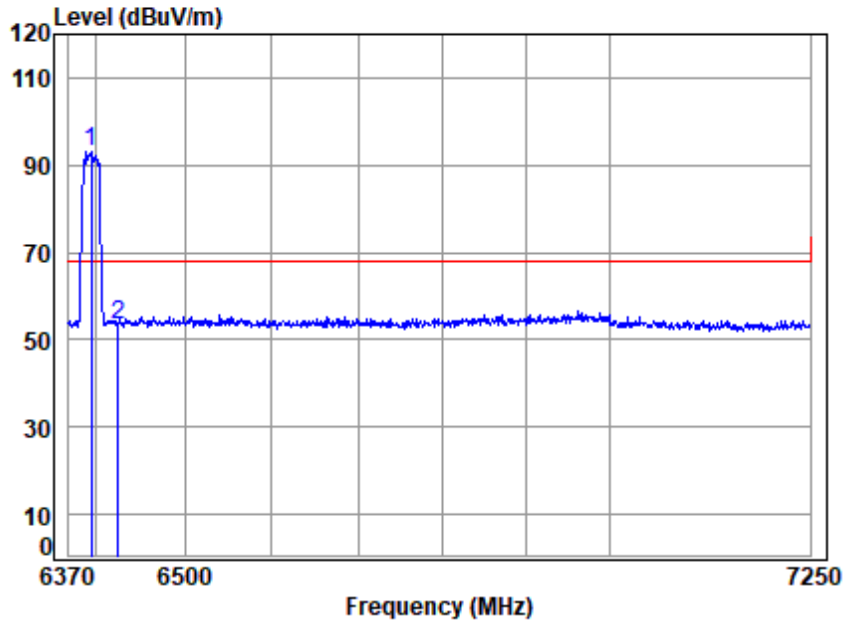

Site : chamber  
 Condition: 3m HORIZONTAL  
 Job No : 00384AT/00385AT  
 Mode : 6395 Band edge  
 : 5G WIFI 11AX20

	Cable	Ant	Preamp	Read	Limit	Over	
Freq	Loss	Factor	Factor	Level	Level	Line	Limit Remark
MHz	dB	dB/m	dB	dBuV	dBuV/m	dBuV/m	dB
1 p 6395.000	8.48	35.17	35.18	84.79	93.26	68.20	25.06 peak
2 6425.000	8.50	35.35	35.20	44.77	53.42	68.20	-14.78 peak



Unless otherwise agreed in writing, this document is issued by the Company subject to its General Conditions of Service printed overleaf, available on request or accessible at <https://www.sgs.com/en/Terms-and-Conditions>. Attention is drawn to the limitation of liability, indemnification and jurisdiction issues defined therein. Any holder of this document is advised that information contained hereon reflects the Company's findings at the time of its intervention only and within the limits of Client's instructions, if any. The Company's sole responsibility is to its Client and this document does not exonerate parties to a transaction from exercising all their rights and obligations under the transaction documents. This document cannot be reproduced except in full, without prior written approval of the Company. Any unauthorized alteration, forgery or falsification of the content or appearance of this document is unlawful and offenders may be prosecuted to the fullest extent of the law. Unless otherwise stated the results shown in this test report refer only to the sample(s) tested and such sample(s) are retained for 30 days only.

Attention: To check the authenticity of testing /inspection report & certificate, please contact us at telephone: (86-755) 8307 1443, or email: CN.Doccheck@sgs.com  
 No.1 Workshop, M-10, Middle Section, Science & Technology Park, Nanshan District, Shenzhen, Guangdong, China 518057 t (86-755) 26012053 f (86-755) 26710594 www.sgsgroup.com.cn  
 中国·广东·深圳市南山区科技园中区M-10栋1号厂房 邮编: 518057 t (86-755) 26012053 f (86-755) 26710594 sgs.china@sgs.com

Polarity: Vertical; Modulation:802.11ax(Full RU0); Bandwidth:20MHz; Channel:High

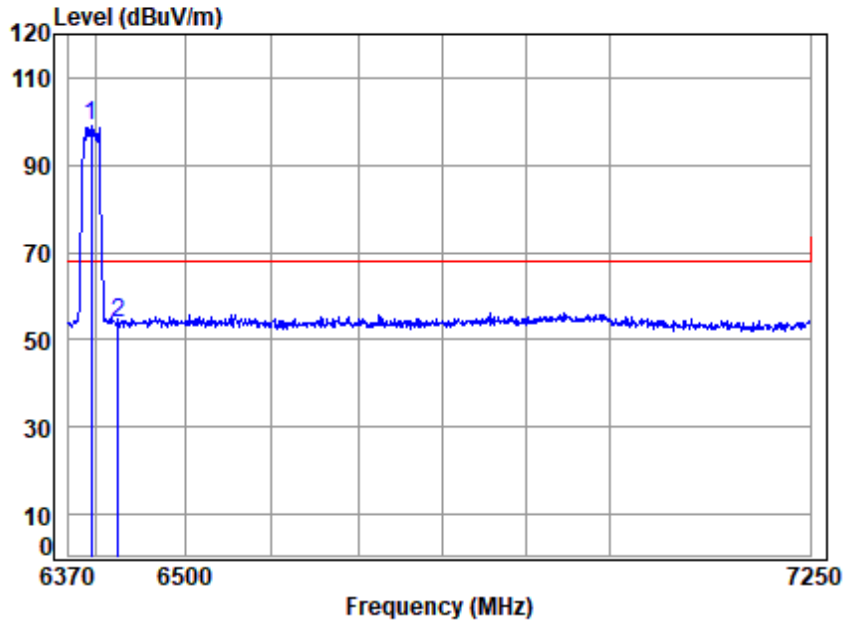

Site : chamber  
 Condition: 3m VERTICAL  
 Job No : 00384AT/00385AT  
 Mode : 6395 Band edge  
 : 5G WIFI 11AX20

	Cable	Ant	Preamp	Read	Limit	Over	
Freq	Loss	Factor	Factor	Level	Line	Limit	Remark
MHz	dB	dB/m	dB	dBuV	dBuV/m	dBuV/m	dB
1 p 6395.000	8.48	35.17	35.18	90.66	99.13	68.20	30.93 peak
2 6425.000	8.50	35.35	35.20	45.41	54.06	68.20	-14.14 peak



Unless otherwise agreed in writing, this document is issued by the Company subject to its General Conditions of Service printed overleaf, available on request or accessible at <https://www.sgs.com/en/Terms-and-Conditions>. Attention is drawn to the limitation of liability, indemnification and jurisdiction issues defined therein. Any holder of this document is advised that information contained hereon reflects the Company's findings at the time of its intervention only and within the limits of Client's instructions, if any. The Company's sole responsibility is to its Client and this document does not exonerate parties to a transaction from exercising all their rights and obligations under the transaction documents. This document cannot be reproduced except in full, without prior written approval of the Company. Any unauthorized alteration, forgery or falsification of the content or appearance of this document is unlawful and offenders may be prosecuted to the fullest extent of the law. Unless otherwise stated the results shown in this test report refer only to the sample(s) tested and such sample(s) are retained for 30 days only.

Attention: To check the authenticity of testing /inspection report & certificate, please contact us at telephone: (86-755) 8307 1443, or email: CN.Doccheck@sgs.com  
 No.1 Workshop, M-10, Middle Section, Science & Technology Park, Nanshan District, Shenzhen, Guangdong, China 518057 t (86-755) 26012053 f (86-755) 26710594 www.sgsgroup.com.cn  
 中国·广东·深圳市南山区科技园中区M-10栋1号厂房 邮编: 518057 t (86-755) 26012053 f (86-755) 26710594 sgs.china@sgs.com



Polarity: Horizontal; Modulation:802.11ax(Full RU0); Bandwidth:40MHz; Channel:Low

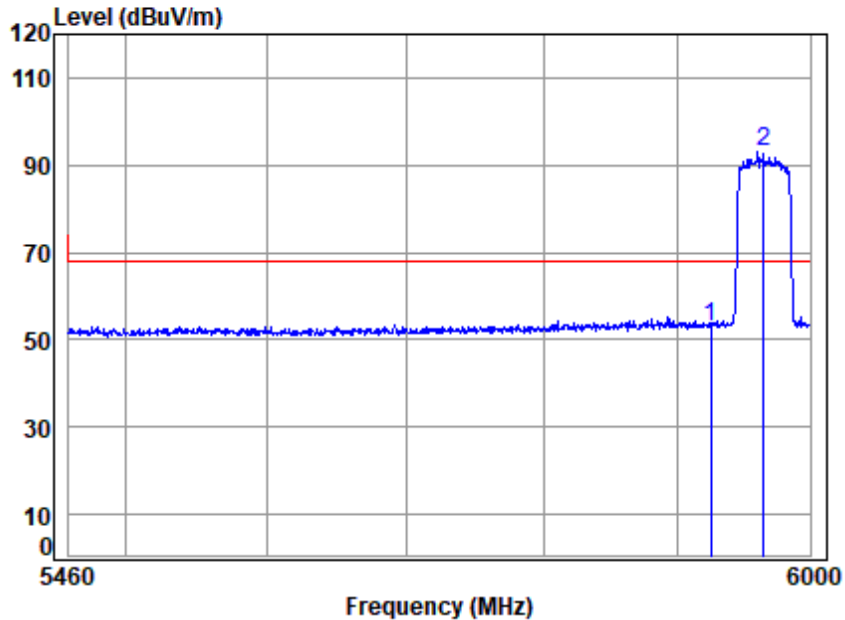

Site : chamber  
 Condition: 3m HORIZONTAL  
 Job No : 00384AT/00385AT  
 Mode : 5965 Band edge  
 : 5G WIFI 11AX40

	Cable	Ant	Preamp	Read	Limit	Over	
Freq	Loss	Factor	Factor	Level	Level	Line	Limit Remark
MHz	dB	dB/m	dB	dBuV	dBuV/m	dBuV/m	dB
1 5925.000	8.12	34.65	34.93	45.26	53.10	68.20	-15.10 peak
2 p 5965.000	8.15	34.76	34.92	85.20	93.19	68.20	24.99 peak



Unless otherwise agreed in writing, this document is issued by the Company subject to its General Conditions of Service printed overleaf, available on request or accessible at <https://www.sgs.com/en/Terms-and-Conditions>. Attention is drawn to the limitation of liability, indemnification and jurisdiction issues defined therein. Any holder of this document is advised that information contained hereon reflects the Company's findings at the time of its intervention only and within the limits of Client's instructions, if any. The Company's sole responsibility is to its Client and this document does not exonerate parties to a transaction from exercising all their rights and obligations under the transaction documents. This document cannot be reproduced except in full, without prior written approval of the Company. Any unauthorized alteration, forgery or falsification of the content or appearance of this document is unlawful and offenders may be prosecuted to the fullest extent of the law. Unless otherwise stated the results shown in this test report refer only to the sample(s) tested and such sample(s) are retained for 30 days only.

Attention: To check the authenticity of testing /inspection report & certificate, please contact us at telephone: (86-755) 8307 1443, or email: CN.Doccheck@sgs.com  
 No.1 Workshop, M-10, Middle Section, Science & Technology Park, Nanshan District, Shenzhen, Guangdong, China 518057 t (86-755) 26012053 f (86-755) 26710594 www.sgs.com.cn  
 中国·广东·深圳市南山区科技园中区M-10栋1号厂房 邮编: 518057 t (86-755) 26012053 f (86-755) 26710594 sgs.china@sgs.com

Polarity: Vertical; Modulation:802.11ax(Full RU0); Bandwidth:40MHz; Channel:Low

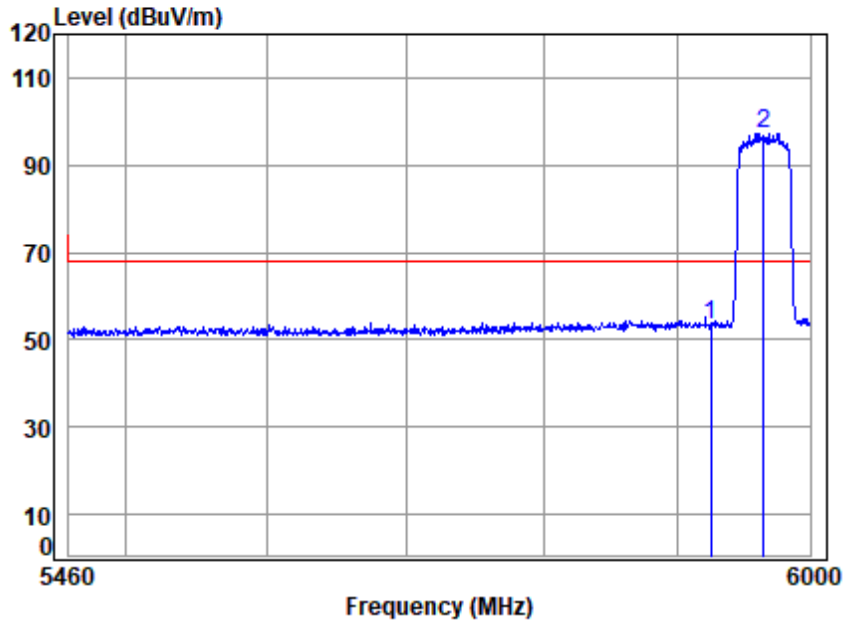

Site : chamber  
 Condition: 3m VERTICAL  
 Job No : 00384AT/00385AT  
 Mode : 5965 Band edge  
 : 5G WIFI 11AX40

	Cable	Ant	Preamp	Read	Limit	Over	
Freq	Loss	Factor	Factor	Level	Level	Line	Limit Remark
MHz	dB	dB/m	dB	dBuV	dBuV/m	dBuV/m	dB
1 5925.000	8.12	34.65	34.93	45.36	53.20	68.20	-15.00 peak
2 p 5965.000	8.15	34.76	34.92	89.26	97.25	68.20	29.05 peak



Unless otherwise agreed in writing, this document is issued by the Company subject to its General Conditions of Service printed overleaf, available on request or accessible at <https://www.sgs.com/en/Terms-and-Conditions>. Attention is drawn to the limitation of liability, indemnification and jurisdiction issues defined therein. Any holder of this document is advised that information contained hereon reflects the Company's findings at the time of its intervention only and within the limits of Client's instructions, if any. The Company's sole responsibility is to its Client and this document does not exonerate parties to a transaction from exercising all their rights and obligations under the transaction documents. This document cannot be reproduced except in full, without prior written approval of the Company. Any unauthorized alteration, forgery or falsification of the content or appearance of this document is unlawful and offenders may be prosecuted to the fullest extent of the law. Unless otherwise stated the results shown in this test report refer only to the sample(s) tested and such sample(s) are retained for 30 days only.

Attention: To check the authenticity of testing /inspection report & certificate, please contact us at telephone: (86-755) 8307 1443, or email: CN.Doccheck@sgs.com

No.1 Workshop, M-10, Middle Section, Science & Technology Park, Nanshan District, Shenzhen, Guangdong, China 518057 t (86-755) 26012053 f (86-755) 26710594 www.sgs.com.cn  
 中国·广东·深圳市南山区科技园中区M-10栋1号厂房 邮编: 518057 t (86-755) 26012053 f (86-755) 26710594 sgs.china@sgs.com

Polarity: Horizontal; Modulation:802.11ax(Full RU0); Bandwidth:40MHz; Channel:High

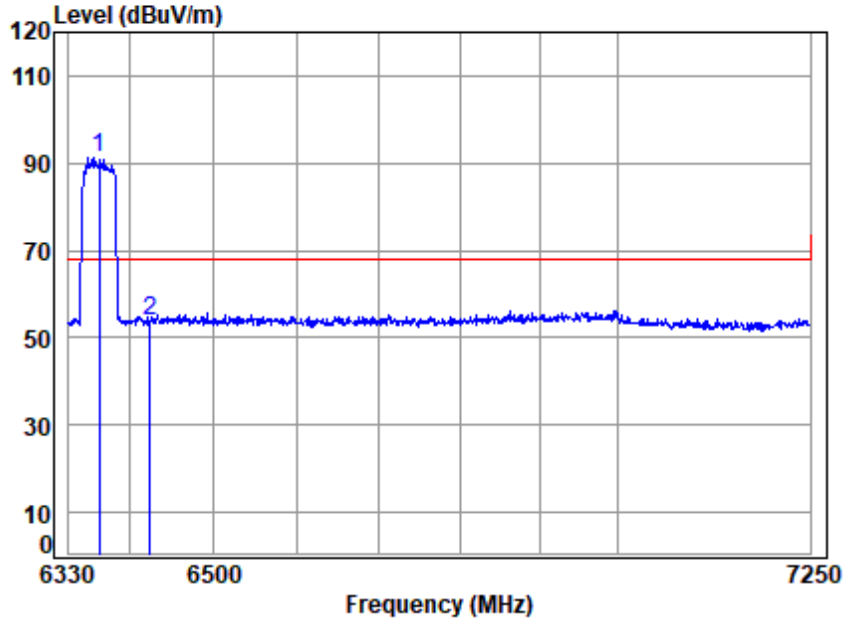

Site : chamber  
 Condition: 3m HORIZONTAL  
 Job No : 00384AT/00385AT  
 Mode : 6365 Band edge  
 : 5G WIFI 11AX40

	Cable	Ant	Preamp	Read	Limit	Over	
Freq	Loss	Factor	Factor	Level	Level	Line	Limit Remark
MHz	dB	dB/m	dB	dBuV	dBuV/m	dBuV/m	dB
1 p 6365.000	8.46	34.99	35.16	82.83	91.12	68.20	22.92 peak
2 6425.000	8.50	35.35	35.20	45.15	53.80	68.20	-14.40 peak



Unless otherwise agreed in writing, this document is issued by the Company subject to its General Conditions of Service printed overleaf, available on request or accessible at <https://www.sgs.com/en/Terms-and-Conditions>. Attention is drawn to the limitation of liability, indemnification and jurisdiction issues defined therein. Any holder of this document is advised that information contained hereon reflects the Company's findings at the time of its intervention only and within the limits of Client's instructions, if any. The Company's sole responsibility is to its Client and this document does not exonerate parties to a transaction from exercising all their rights and obligations under the transaction documents. This document cannot be reproduced except in full, without prior written approval of the Company. Any unauthorized alteration, forgery or falsification of the content or appearance of this document is unlawful and offenders may be prosecuted to the fullest extent of the law. Unless otherwise stated the results shown in this test report refer only to the sample(s) tested and such sample(s) are retained for 30 days only.



Polarity: Vertical; Modulation:802.11ax(Full RU0); Bandwidth:40MHz; Channel:High

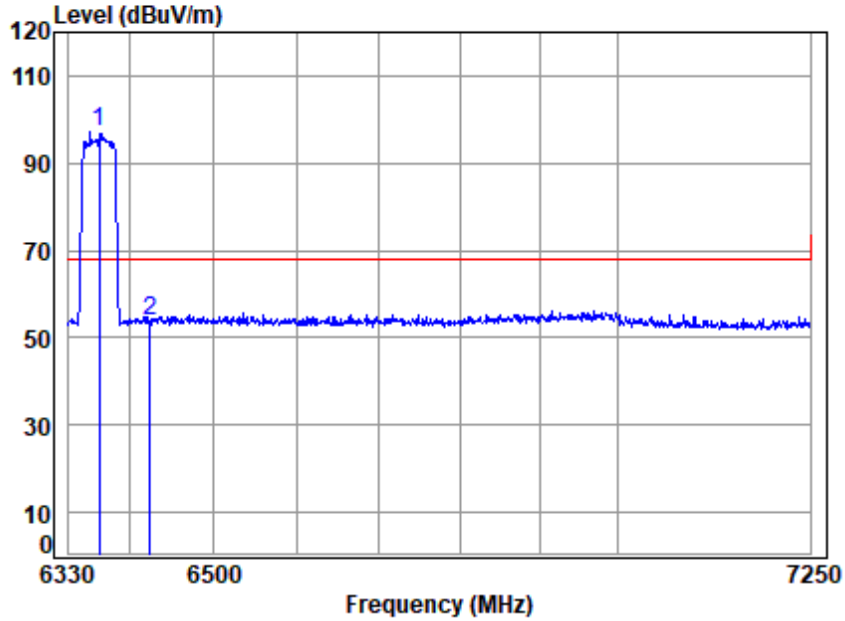

Site : chamber  
 Condition: 3m VERTICAL  
 Job No : 00384AT/00385AT  
 Mode : 6365 Band edge  
 : 5G WIFI 11AX40

	Cable	Ant	Preamp	Read	Limit	Over	
Freq	Loss	Factor	Factor	Level	Level	Line	Limit Remark
MHz	dB	dB/m	dB	dBuV	dBuV/m	dBuV/m	dB
1 p 6365.000	8.46	34.99	35.16	89.05	97.34	68.20	29.14 peak
2 6425.000	8.50	35.35	35.20	45.23	53.88	68.20	-14.32 peak



Unless otherwise agreed in writing, this document is issued by the Company subject to its General Conditions of Service printed overleaf, available on request or accessible at <https://www.sgs.com/en/Terms-and-Conditions>. Attention is drawn to the limitation of liability, indemnification and jurisdiction issues defined therein. Any holder of this document is advised that information contained hereon reflects the Company's findings at the time of its intervention only and within the limits of Client's instructions, if any. The Company's sole responsibility is to its Client and this document does not exonerate parties to a transaction from exercising all their rights and obligations under the transaction documents. This document cannot be reproduced except in full, without prior written approval of the Company. Any unauthorized alteration, forgery or falsification of the content or appearance of this document is unlawful and offenders may be prosecuted to the fullest extent of the law. Unless otherwise stated the results shown in this test report refer only to the sample(s) tested and such sample(s) are retained for 30 days only.

Attention: To check the authenticity of testing /inspection report & certificate, please contact us at telephone: (86-755) 8307 1443, or email: CN.Doccheck@sgs.com  
 No.1 Workshop, M-10, Middle Section, Science & Technology Park, Nanshan District, Shenzhen, Guangdong, China 518057 t (86-755) 26012053 f (86-755) 26710594 www.sgs.com.cn  
 中国·广东·深圳市南山区科技园中区M-10栋1号厂房 邮编: 518057 t (86-755) 26012053 f (86-755) 26710594 sgs.china@sgs.com

Polarity: Horizontal; Modulation:802.11ax(Full RU0); Bandwidth:80MHz; Channel:Low

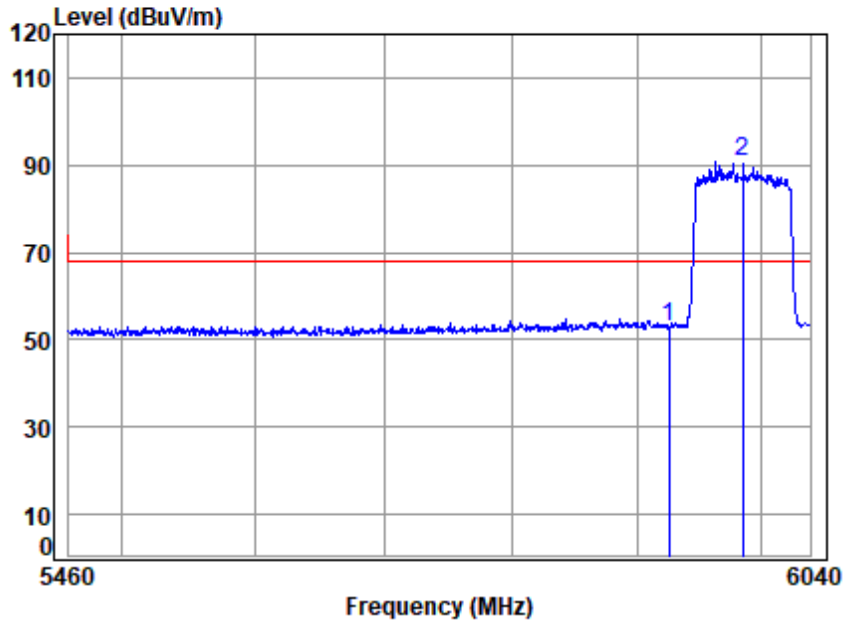

Site : chamber  
 Condition: 3m HORIZONTAL  
 Job No : 00384AT/00385AT  
 Mode : 5985 Band edge  
 : 5G WIFI 11AX80

	Cable	Ant	Preamp	Read	Limit	Over	
Freq	Loss	Factor	Factor	Level	Level	Line	Limit Remark
MHz	dB	dB/m	dB	dBuV	dBuV/m	dBuV/m	dB
1 5925.000	8.12	34.65	34.93	45.21	53.05	68.20	-15.15 peak
2 p 5985.000	8.16	34.84	34.91	82.59	90.68	68.20	22.48 peak



Unless otherwise agreed in writing, this document is issued by the Company subject to its General Conditions of Service printed overleaf, available on request or accessible at <https://www.sgs.com/en/Terms-and-Conditions>. Attention is drawn to the limitation of liability, indemnification and jurisdiction issues defined therein. Any holder of this document is advised that information contained hereon reflects the Company's findings at the time of its intervention only and within the limits of Client's instructions, if any. The Company's sole responsibility is to its Client and this document does not exonerate parties to a transaction from exercising all their rights and obligations under the transaction documents. This document cannot be reproduced except in full, without prior written approval of the Company. Any unauthorized alteration, forgery or falsification of the content or appearance of this document is unlawful and offenders may be prosecuted to the fullest extent of the law. Unless otherwise stated the results shown in this test report refer only to the sample(s) tested and such sample(s) are retained for 30 days only.

Attention: To check the authenticity of testing /inspection report & certificate, please contact us at telephone: (86-755) 8307 1443, or email: CN.Doccheck@sgs.com  
 No.1 Workshop, M-10, Middle Section, Science & Technology Park, Nanshan District, Shenzhen, Guangdong, China 518057 t (86-755) 26012053 f (86-755) 26710594 www.sgsgroup.com.cn  
 中国·广东·深圳市南山区科技园中区M-10栋1号厂房 邮编: 518057 t (86-755) 26012053 f (86-755) 26710594 sgs.china@sgs.com

Polarity: Vertical; Modulation:802.11ax(Full RU0); Bandwidth:80MHz; Channel:Low

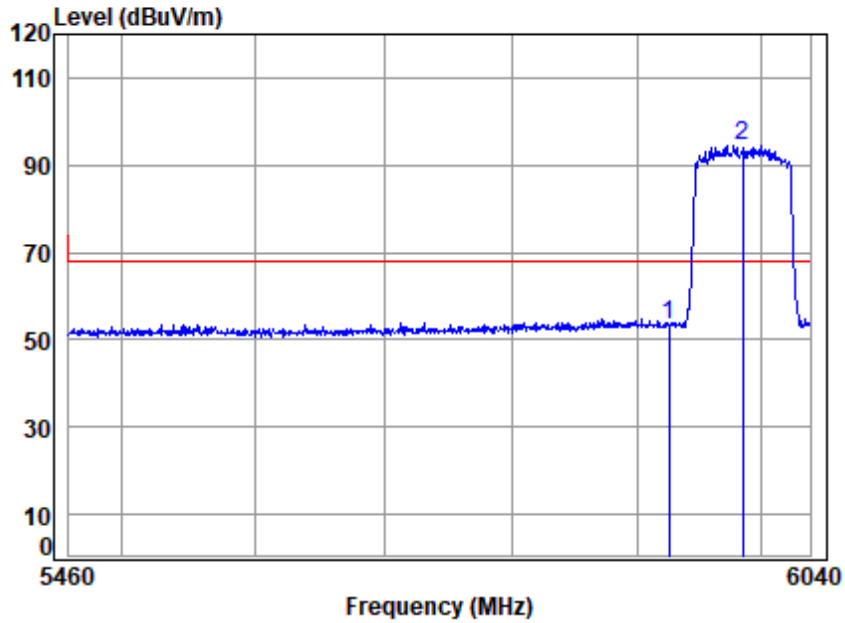

Site : chamber  
 Condition: 3m VERTICAL  
 Job No : 00384AT/00385AT  
 Mode : 5985 Band edge  
 : 5G WIFI 11AX80

	Cable	Ant	Preamp	Read	Limit	Over	
Freq	Loss	Factor	Factor	Level	Level	Line	Limit Remark
MHz	dB	dB/m	dB	dBuV	dBuV/m	dBuV/m	dB
1	5925.000	8.12	34.65	34.93	45.34	53.18	68.20 -15.02 peak
2 p	5985.000	8.16	34.84	34.91	86.56	94.65	68.20 26.45 peak



Unless otherwise agreed in writing, this document is issued by the Company subject to its General Conditions of Service printed overleaf, available on request or accessible at <https://www.sgs.com/en/Terms-and-Conditions>. Attention is drawn to the limitation of liability, indemnification and jurisdiction issues defined therein. Any holder of this document is advised that information contained hereon reflects the Company's findings at the time of its intervention only and within the limits of Client's instructions, if any. The Company's sole responsibility is to its Client and this document does not exonerate parties to a transaction from exercising all their rights and obligations under the transaction documents. This document cannot be reproduced except in full, without prior written approval of the Company. Any unauthorized alteration, forgery or falsification of the content or appearance of this document is unlawful and offenders may be prosecuted to the fullest extent of the law. Unless otherwise stated the results shown in this test report refer only to the sample(s) tested and such sample(s) are retained for 30 days only.

Attention: To check the authenticity of testing /inspection report & certificate, please contact us at telephone: (86-755) 8307 1443, or email: CN.Doccheck@sgs.com  
 No.1 Workshop, M-10, Middle Section, Science & Technology Park, Nanshan District, Shenzhen, Guangdong, China 518057 t (86-755) 26012053 f (86-755) 26710594 www.sgs.com.cn  
 中国·广东·深圳市南山区科技园中区M-10栋1号厂房 邮编: 518057 t (86-755) 26012053 f (86-755) 26710594 sgs.china@sgs.com



Polarity: Horizontal; Modulation:802.11ax(Full RU0); Bandwidth:80MHz; Channel:High

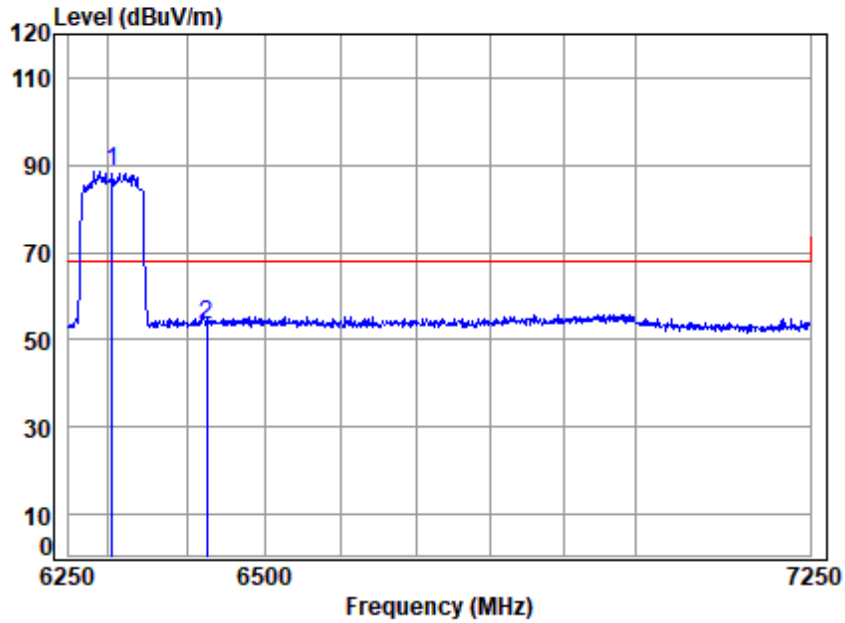

Site : chamber  
 Condition: 3m HORIZONTAL  
 Job No : 00384AT/00385AT  
 Mode : 6305 Band edge  
 : 5G WIFI 11AX80

	Cable	Ant	Preamp	Read	Limit	Over	
Freq	Loss	Factor	Factor	Level	Level	Line	Limit Remark
MHz	dB	dB/m	dB	dBuV	dBuV/m	dBuV/m	dB
1 p 6305.000	8.41	34.99	35.12	80.11	88.39	68.20	20.19 peak
2 6425.000	8.50	35.35	35.20	44.94	53.59	68.20	-14.61 peak



Unless otherwise agreed in writing, this document is issued by the Company subject to its General Conditions of Service printed overleaf, available on request or accessible at <https://www.sgs.com/en/Terms-and-Conditions>. Attention is drawn to the limitation of liability, indemnification and jurisdiction issues defined therein. Any holder of this document is advised that information contained hereon reflects the Company's findings at the time of its intervention only and within the limits of Client's instructions, if any. The Company's sole responsibility is to its Client and this document does not exonerate parties to a transaction from exercising all their rights and obligations under the transaction documents. This document cannot be reproduced except in full, without prior written approval of the Company. Any unauthorized alteration, forgery or falsification of the content or appearance of this document is unlawful and offenders may be prosecuted to the fullest extent of the law. Unless otherwise stated the results shown in this test report refer only to the sample(s) tested and such sample(s) are retained for 30 days only.

Attention: To check the authenticity of testing /inspection report & certificate, please contact us at telephone: (86-755) 8307 1443, or email: CN.Doccheck@sgs.com

No.1 Workshop, M-10, Middle Section, Science & Technology Park, Nanshan District, Shenzhen, Guangdong, China 518057 t (86-755) 26012053 f (86-755) 26710594 www.sgsgroup.com.cn  
 中国·广东·深圳市南山区科技园中区M-10栋1号厂房 邮编: 518057 t (86-755) 26012053 f (86-755) 26710594 sgs.china@sgs.com

Polarity: Vertical; Modulation:802.11ax(Full RU0); Bandwidth:80MHz; Channel:High

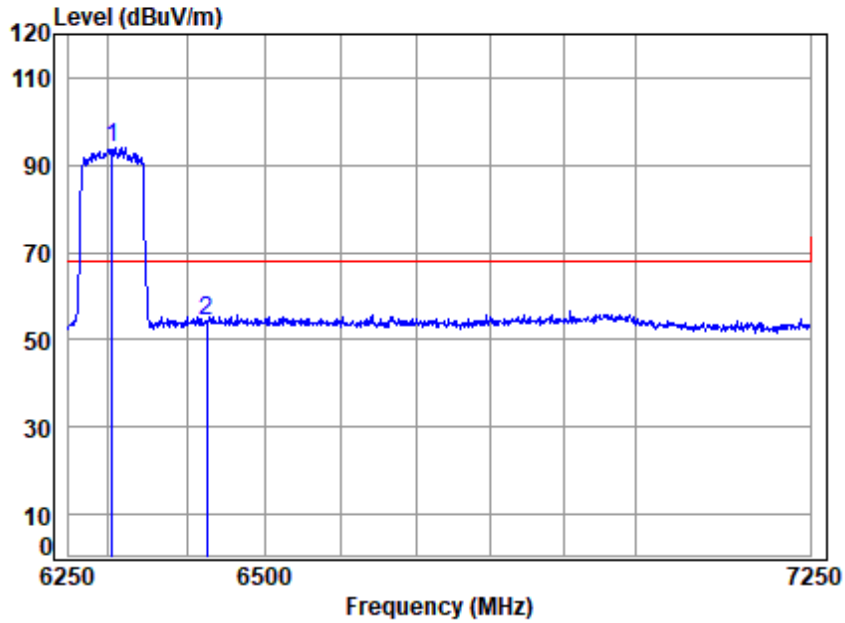

Site : chamber  
 Condition: 3m VERTICAL  
 Job No : 00384AT/00385AT  
 Mode : 6305 Band edge  
 : 5G WIFI 11AX80

	Cable	Ant	Preamp	Read	Limit	Over	
Freq	Loss	Factor	Factor	Level	Level	Line	Limit Remark
MHz	dB	dB/m	dB	dBuV	dBuV/m	dBuV/m	dB
1 p 6305.000	8.41	34.99	35.12	85.88	94.16	68.20	25.96 peak
2 6425.000	8.50	35.35	35.20	45.58	54.23	68.20	-13.97 peak



Unless otherwise agreed in writing, this document is issued by the Company subject to its General Conditions of Service printed overleaf, available on request or accessible at <https://www.sgs.com/en/Terms-and-Conditions>. Attention is drawn to the limitation of liability, indemnification and jurisdiction issues defined therein. Any holder of this document is advised that information contained hereon reflects the Company's findings at the time of its intervention only and within the limits of Client's instructions, if any. The Company's sole responsibility is to its Client and this document does not exonerate parties to a transaction from exercising all their rights and obligations under the transaction documents. This document cannot be reproduced except in full, without prior written approval of the Company. Any unauthorized alteration, forgery or falsification of the content or appearance of this document is unlawful and offenders may be prosecuted to the fullest extent of the law. Unless otherwise stated the results shown in this test report refer only to the sample(s) tested and such sample(s) are retained for 30 days only.

Attention: To check the authenticity of testing /inspection report & certificate, please contact us at telephone: (86-755) 8307 1443, or email: CN.Doccheck@sgs.com  
 No.1 Workshop, M-10, Middle Section, Science & Technology Park, Nanshan District, Shenzhen, Guangdong, China 518057 t (86-755) 26012053 f (86-755) 26710594 www.sgs.com.cn  
 中国·广东·深圳市南山区科技园中区M-10栋1号厂房 邮编: 518057 t (86-755) 26012053 f (86-755) 26710594 sgs.china@sgs.com

Polarity: Horizontal; Modulation:802.11ax(Full RU0); Bandwidth:160MHz; Channel:Low

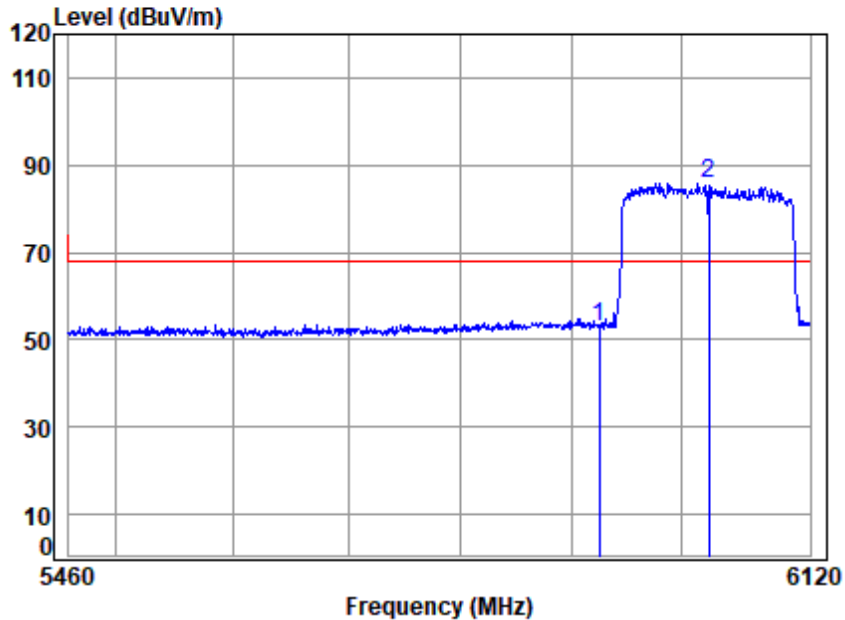

Site : chamber  
 Condition: 3m HORIZONTAL  
 Job No : 00384AT/00385AT  
 Mode : 6025 Band edge  
 : 5G WIFI 11AX160

	Cable	Ant	Preamp	Read	Limit	Over		
Freq	Loss	Factor	Factor	Level	Level	Line	Limit	Remark
MHz	dB	dB/m	dB	dBuV	dBuV/m	dBuV/m	dB	
1	5925.000	8.12	34.65	34.93	45.29	53.13	68.20	-15.07 peak
2 p	6025.000	8.19	34.95	34.92	77.76	85.98	68.20	17.78 peak



Unless otherwise agreed in writing, this document is issued by the Company subject to its General Conditions of Service printed overleaf, available on request or accessible at <https://www.sgs.com/en/Terms-and-Conditions>. Attention is drawn to the limitation of liability, indemnification and jurisdiction issues defined therein. Any holder of this document is advised that information contained hereon reflects the Company's findings at the time of its intervention only and within the limits of Client's instructions, if any. The Company's sole responsibility is to its Client and this document does not exonerate parties to a transaction from exercising all their rights and obligations under the transaction documents. This document cannot be reproduced except in full, without prior written approval of the Company. Any unauthorized alteration, forgery or falsification of the content or appearance of this document is unlawful and offenders may be prosecuted to the fullest extent of the law. Unless otherwise stated the results shown in this test report refer only to the sample(s) tested and such sample(s) are retained for 30 days only.

Attention: To check the authenticity of testing /inspection report & certificate, please contact us at telephone: (86-755) 8307 1443, or email: CN.Doccheck@sgs.com

No.1 Workshop, M-10, Middle Section, Science & Technology Park, Nanshan District, Shenzhen, Guangdong, China 518057 t (86-755) 26012053 f (86-755) 26710594 www.sgs.com.cn  
 中国·广东·深圳市南山区科技园中区M-10栋1号厂房 邮编: 518057 t (86-755) 26012053 f (86-755) 26710594 sgs.china@sgs.com

Polarity: Vertical; Modulation:802.11ax(Full RU0); Bandwidth:160MHz; Channel:Low

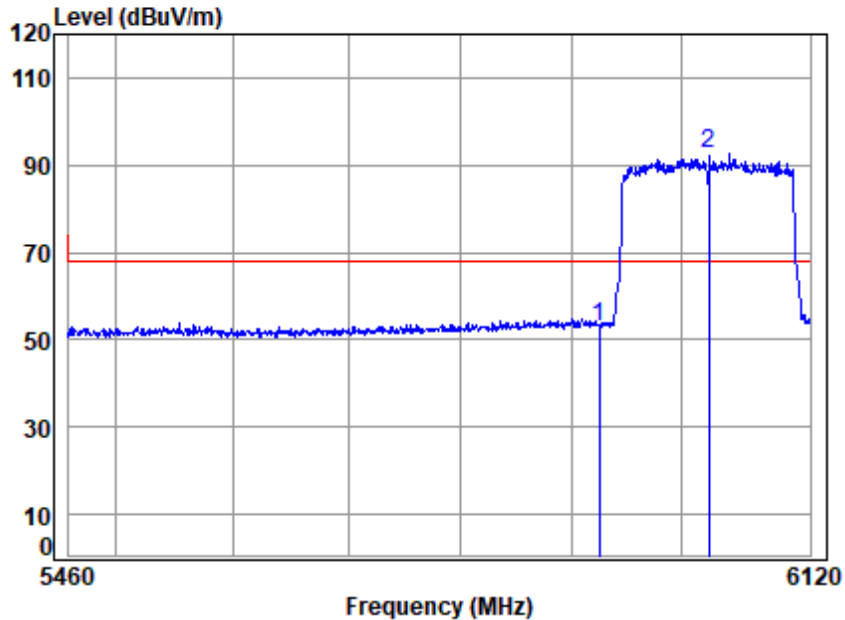

Site : chamber  
 Condition: 3m VERTICAL  
 Job No : 00384AT/00385AT  
 Mode : 6025 Band edge  
 : 5G WIFI 11AX160

	Cable	Ant	Preamp	Read	Limit	Over		
Freq	Loss	Factor	Factor	Level	Level	Line	Limit	Remark
MHz	dB	dB/m	dB	dBuV	dBuV/m	dBuV/m	dB	
1	8.12	34.65	34.93	45.29	53.13	68.20	-15.07	peak
2 p	8.19	34.95	34.92	84.43	92.65	68.20	24.45	peak



Unless otherwise agreed in writing, this document is issued by the Company subject to its General Conditions of Service printed overleaf, available on request or accessible at <https://www.sgs.com/en/Terms-and-Conditions>. Attention is drawn to the limitation of liability, indemnification and jurisdiction issues defined therein. Any holder of this document is advised that information contained hereon reflects the Company's findings at the time of its intervention only and within the limits of Client's instructions, if any. The Company's sole responsibility is to its Client and this document does not exonerate parties to a transaction from exercising all their rights and obligations under the transaction documents. This document cannot be reproduced except in full, without prior written approval of the Company. Any unauthorized alteration, forgery or falsification of the content or appearance of this document is unlawful and offenders may be prosecuted to the fullest extent of the law. Unless otherwise stated the results shown in this test report refer only to the sample(s) tested and such sample(s) are retained for 30 days only.

Attention: To check the authenticity of testing /inspection report & certificate, please contact us at telephone: (86-755) 8307 1443, or email: CN.Doccheck@sgs.com  
 No.1 Workshop, M-10, Middle Section, Science & Technology Park, Nanshan District, Shenzhen, Guangdong, China 518057 t (86-755) 26012053 f (86-755) 26710594 www.sgs.com.cn  
 中国·广东·深圳市南山区科技园中区M-10栋1号厂房 邮编: 518057 t (86-755) 26012053 f (86-755) 26710594 sgs.china@sgs.com



Polarity: Horizontal; Modulation:802.11ax(Full RU0); Bandwidth:160MHz; Channel:High

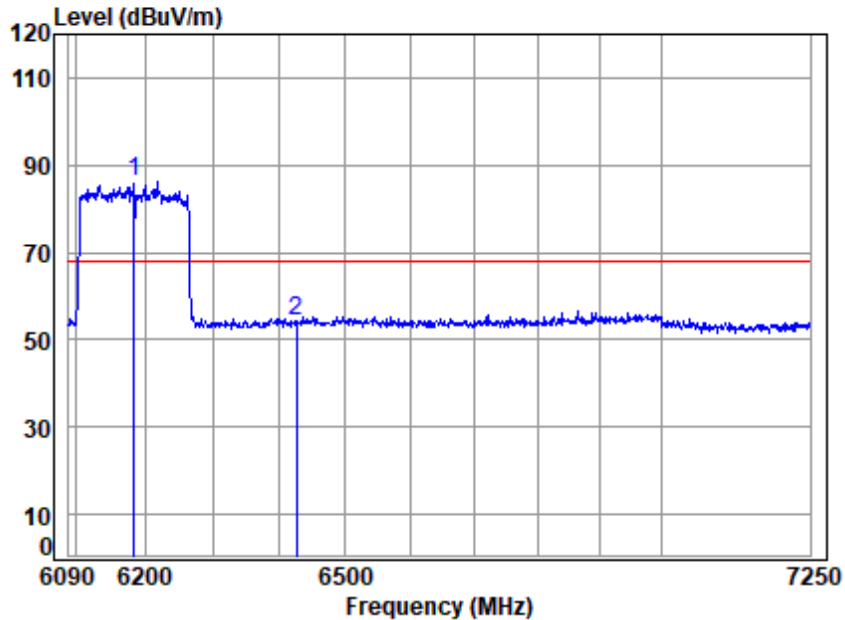

Site : chamber  
 Condition: 3m HORIZONTAL  
 Job No : 00384AT/00385AT  
 Mode : 6185 Band edge  
 : 5G WIFI 11AX160

	Cable	Ant	Preamp	Read	Limit	Over	
Freq	Loss	Factor	Factor	Level	Line	Limit	Remark
MHz	dB	dB/m	dB	dBuV	dBuV/m	dBuV/m	dB
1 p 6185.000	8.32	34.76	35.03	77.98	86.03	68.20	17.83 peak
2 6425.000	8.50	35.35	35.20	45.48	54.13	68.20	-14.07 peak



Unless otherwise agreed in writing, this document is issued by the Company subject to its General Conditions of Service printed overleaf, available on request or accessible at <https://www.sgs.com/en/Terms-and-Conditions>. Attention is drawn to the limitation of liability, indemnification and jurisdiction issues defined therein. Any holder of this document is advised that information contained hereon reflects the Company's findings at the time of its intervention only and within the limits of Client's instructions, if any. The Company's sole responsibility is to its Client and this document does not exonerate parties to a transaction from exercising all their rights and obligations under the transaction documents. This document cannot be reproduced except in full, without prior written approval of the Company. Any unauthorized alteration, forgery or falsification of the content or appearance of this document is unlawful and offenders may be prosecuted to the fullest extent of the law. Unless otherwise stated the results shown in this test report refer only to the sample(s) tested and such sample(s) are retained for 30 days only.

Attention: To check the authenticity of testing /inspection report & certificate, please contact us at telephone: (86-755) 8307 1443, or email: CN.Doccheck@sgs.com  
 No.1 Workshop, M-10, Middle Section, Science & Technology Park, Nanshan District, Shenzhen, Guangdong, China 518057 t (86-755) 26012053 f (86-755) 26710594 www.sgs.com.cn  
 中国·广东·深圳市南山区科技园中区M-10栋1号厂房 邮编: 518057 t (86-755) 26012053 f (86-755) 26710594 sgs.china@sgs.com

Polarity: Vertical; Modulation:802.11ax(Full RU0); Bandwidth:160MHz; Channel:High

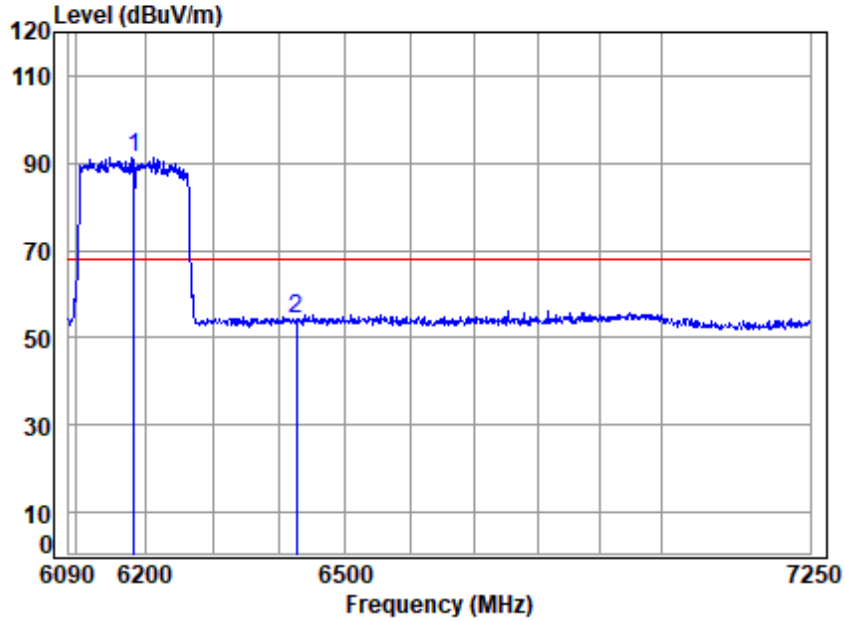

Site : chamber  
 Condition: 3m VERTICAL  
 Job No : 00384AT/00385AT  
 Mode : 6185 Band edge  
 : 5G WIFI 11AX160

	Cable	Ant	Preamp	Read	Limit	Over	
Freq	Loss	Factor	Factor	Level	Level	Line	Limit Remark
MHz	dB	dB/m	dB	dBuV	dBuV/m	dBuV/m	dB
1 p 6185.000	8.32	34.76	35.03	83.26	91.31	68.20	23.11 peak
2 6425.000	8.50	35.35	35.20	45.55	54.20	68.20	-14.00 peak



Unless otherwise agreed in writing, this document is issued by the Company subject to its General Conditions of Service printed overleaf, available on request or accessible at <https://www.sgs.com/en/Terms-and-Conditions>. Attention is drawn to the limitation of liability, indemnification and jurisdiction issues defined therein. Any holder of this document is advised that information contained hereon reflects the Company's findings at the time of its intervention only and within the limits of Client's instructions, if any. The Company's sole responsibility is to its Client and this document does not exonerate parties to a transaction from exercising all their rights and obligations under the transaction documents. This document cannot be reproduced except in full, without prior written approval of the Company. Any unauthorized alteration, forgery or falsification of the content or appearance of this document is unlawful and offenders may be prosecuted to the fullest extent of the law. Unless otherwise stated the results shown in this test report refer only to the sample(s) tested and such sample(s) are retained for 30 days only.

Attention: To check the authenticity of testing /inspection report & certificate, please contact us at telephone: (86-755) 8307 1443, or email: CN.Doccheck@sgs.com

No.1 Workshop, M-10, Middle Section, Science & Technology Park, Nanshan District, Shenzhen, Guangdong, China 518057 t (86-755) 26012053 f (86-755) 26710594 www.sgs.com.cn  
 中国·广东·深圳市南山区科技园中区M-10栋1号厂房 邮编: 518057 t (86-755) 26012053 f (86-755) 26710594 sgs.china@sgs.com

Polarity: Horizontal; Modulation:802.11ax(Full RU0); Bandwidth:20MHz; Channel:Low

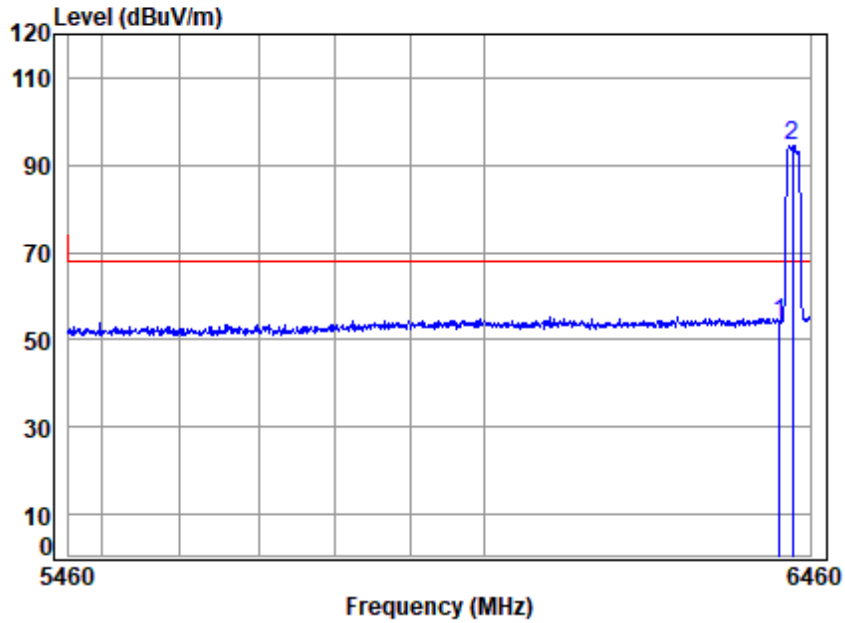

Site : chamber  
 Condition: 3m HORIZONTAL  
 Job No : 00384AT/00385AT  
 Mode : 6435 Band edge  
 : 5G WIFI 11AX20

	Cable	Ant	Preamp	Read	Limit	Over	
Freq	Loss	Factor	Factor	Level	Level	Line	Limit Remark
MHz	dB	dB/m	dB	dBuV	dBuV/m	dBuV/m	dB
1	6415.000	8.50	35.29	35.19	45.04	53.64	68.20 -14.56 peak
2 p	6435.000	8.51	35.41	35.20	85.84	94.56	68.20 26.36 peak



Unless otherwise agreed in writing, this document is issued by the Company subject to its General Conditions of Service printed overleaf, available on request or accessible at <https://www.sgs.com/en/Terms-and-Conditions>. Attention is drawn to the limitation of liability, indemnification and jurisdiction issues defined therein. Any holder of this document is advised that information contained hereon reflects the Company's findings at the time of its intervention only and within the limits of Client's instructions, if any. The Company's sole responsibility is to its Client and this document does not exonerate parties to a transaction from exercising all their rights and obligations under the transaction documents. This document cannot be reproduced except in full, without prior written approval of the Company. Any unauthorized alteration, forgery or falsification of the content or appearance of this document is unlawful and offenders may be prosecuted to the fullest extent of the law. Unless otherwise stated the results shown in this test report refer only to the sample(s) tested and such sample(s) are retained for 30 days only.

Attention: To check the authenticity of testing /inspection report & certificate, please contact us at telephone: (86-755) 8307 1443, or email: CN.Doccheck@sgs.com  
 No.1 Workshop, M-10, Middle Section, Science & Technology Park, Nanshan District, Shenzhen, Guangdong, China 518057 t (86-755) 26012053 f (86-755) 26710594 www.sgs.com.cn  
 中国·广东·深圳市南山区科技园中区M-10栋1号厂房 邮编: 518057 t (86-755) 26012053 f (86-755) 26710594 sgs.china@sgs.com

Polarity: Vertical; Modulation:802.11ax(Full RU0); Bandwidth:20MHz; Channel:Low

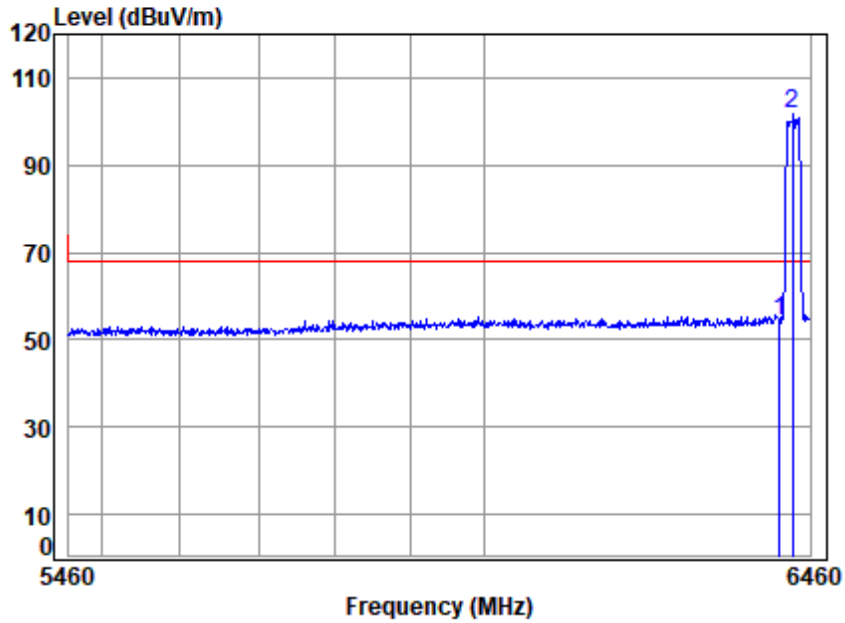

Site : chamber  
 Condition: 3m VERTICAL  
 Job No : 00384AT/00385AT  
 Mode : 6435 Band edge  
 : 5G WIFI 11AX20

	Cable	Ant	Preamp	Read	Limit	Over	
Freq	Loss	Factor	Factor	Level	Level	Line	Limit Remark
MHz	dB	dB/m	dB	dBuV	dBuV/m	dBuV/m	dB
1	6415.000	8.50	35.29	35.19	45.54	54.14	68.20 -14.06 peak
2 p	6435.000	8.51	35.41	35.20	93.19	101.91	68.20 33.71 peak



Unless otherwise agreed in writing, this document is issued by the Company subject to its General Conditions of Service printed overleaf, available on request or accessible at <https://www.sgs.com/en/Terms-and-Conditions>. Attention is drawn to the limitation of liability, indemnification and jurisdiction issues defined therein. Any holder of this document is advised that information contained hereon reflects the Company's findings at the time of its intervention only and within the limits of Client's instructions, if any. The Company's sole responsibility is to its Client and this document does not exonerate parties to a transaction from exercising all their rights and obligations under the transaction documents. This document cannot be reproduced except in full, without prior written approval of the Company. Any unauthorized alteration, forgery or falsification of the content or appearance of this document is unlawful and offenders may be prosecuted to the fullest extent of the law. Unless otherwise stated the results shown in this test report refer only to the sample(s) tested and such sample(s) are retained for 30 days only.

Attention: To check the authenticity of testing /inspection report & certificate, please contact us at telephone: (86-755) 8307 1443, or email: CN.Doccheck@sgs.com  
 No.1 Workshop, M-10, Middle Section, Science & Technology Park, Nanshan District, Shenzhen, Guangdong, China 518057 t (86-755) 26012053 f (86-755) 26710594 www.sgsgroup.com.cn  
 中国·广东·深圳市南山区科技园中区M-10栋1号厂房 邮编: 518057 t (86-755) 26012053 f (86-755) 26710594 sgs.china@sgs.com



Polarity: Horizontal; Modulation:802.11ax(Full RU0); Bandwidth:20MHz; Channel:High

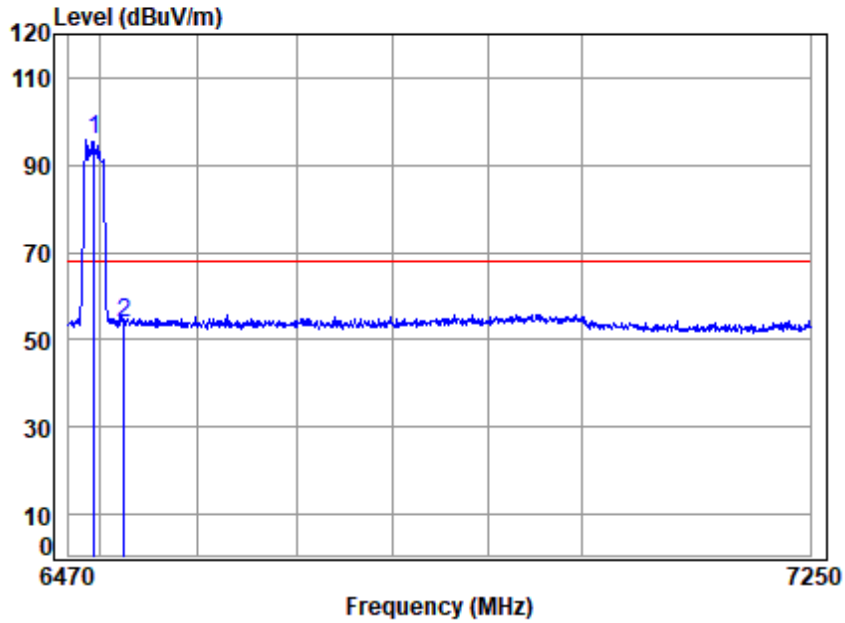

Site : chamber  
 Condition: 3m HORIZONTAL  
 Job No : 00384AT/00385AT  
 Mode : 6495 Band edge  
 : 5G WIFI 11AX20

	Cable	Ant	Preamp	Read	Limit	Over	
Freq	Loss	Factor	Factor	Level	Level	Line	Limit Remark
MHz	dB	dB/m	dB	dBuV	dBuV/m	dBuV/m	dB
1 p 6495.000	8.56	35.59	35.24	86.69	95.60	68.20	27.40 peak
2 6525.000	8.58	35.55	35.26	45.07	53.94	68.20	-14.26 peak



Unless otherwise agreed in writing, this document is issued by the Company subject to its General Conditions of Service printed overleaf, available on request or accessible at <https://www.sgs.com/en/Terms-and-Conditions>. Attention is drawn to the limitation of liability, indemnification and jurisdiction issues defined therein. Any holder of this document is advised that information contained hereon reflects the Company's findings at the time of its intervention only and within the limits of Client's instructions, if any. The Company's sole responsibility is to its Client and this document does not exonerate parties to a transaction from exercising all their rights and obligations under the transaction documents. This document cannot be reproduced except in full, without prior written approval of the Company. Any unauthorized alteration, forgery or falsification of the content or appearance of this document is unlawful and offenders may be prosecuted to the fullest extent of the law. Unless otherwise stated the results shown in this test report refer only to the sample(s) tested and such sample(s) are retained for 30 days only.

Attention: To check the authenticity of testing /inspection report & certificate, please contact us at telephone: (86-755) 8307 1443, or email: CN.Doccheck@sgs.com  
 No.1 Workshop, M-10, Middle Section, Science & Technology Park, Nanshan District, Shenzhen, Guangdong, China 518057 t (86-755) 26012053 f (86-755) 26710594 www.sgs.com.cn  
 中国·广东·深圳市南山区科技园中区M-10栋1号厂房 邮编: 518057 t (86-755) 26012053 f (86-755) 26710594 sgs.china@sgs.com

Polarity: Vertical; Modulation:802.11ax(Full RU0); Bandwidth:20MHz; Channel:High

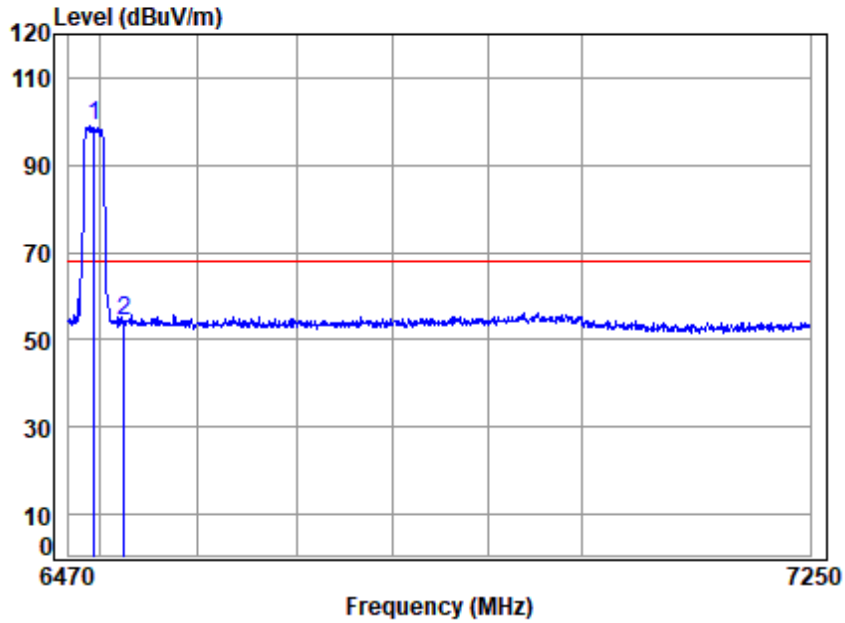

Site : chamber  
 Condition: 3m VERTICAL  
 Job No : 00384AT/00385AT  
 Mode : 6495 Band edge  
 : 5G WIFI 11AX20

	Cable	Ant	Preamp	Read	Limit	Over	
Freq	Loss	Factor	Factor	Level	Level	Line	Limit Remark
MHz	dB	dB/m	dB	dBuV	dBuV/m	dBuV/m	dB
1 p 6495.000	8.56	35.59	35.24	90.21	99.12	68.20	30.92 peak
2 6525.000	8.58	35.55	35.26	45.33	54.20	68.20	-14.00 peak



Unless otherwise agreed in writing, this document is issued by the Company subject to its General Conditions of Service printed overleaf, available on request or accessible at <https://www.sgs.com/en/Terms-and-Conditions>. Attention is drawn to the limitation of liability, indemnification and jurisdiction issues defined therein. Any holder of this document is advised that information contained hereon reflects the Company's findings at the time of its intervention only and within the limits of Client's instructions, if any. The Company's sole responsibility is to its Client and this document does not exonerate parties to a transaction from exercising all their rights and obligations under the transaction documents. This document cannot be reproduced except in full, without prior written approval of the Company. Any unauthorized alteration, forgery or falsification of the content or appearance of this document is unlawful and offenders may be prosecuted to the fullest extent of the law. Unless otherwise stated the results shown in this test report refer only to the sample(s) tested and such sample(s) are retained for 30 days only.

Attention: To check the authenticity of testing /inspection report & certificate, please contact us at telephone: (86-755) 8307 1443, or email: CN.Doccheck@sgs.com  
 No.1 Workshop, M-10, Middle Section, Science & Technology Park, Nanshan District, Shenzhen, Guangdong, China 518057 t (86-755) 26012053 f (86-755) 26710594 www.sgs.com.cn  
 中国·广东·深圳市南山区科技园中区M-10栋1号厂房 邮编: 518057 t (86-755) 26012053 f (86-755) 26710594 sgs.china@sgs.com

Polarity: Horizontal; Modulation:802.11ax(Full RU0); Bandwidth:40MHz; Channel:Low

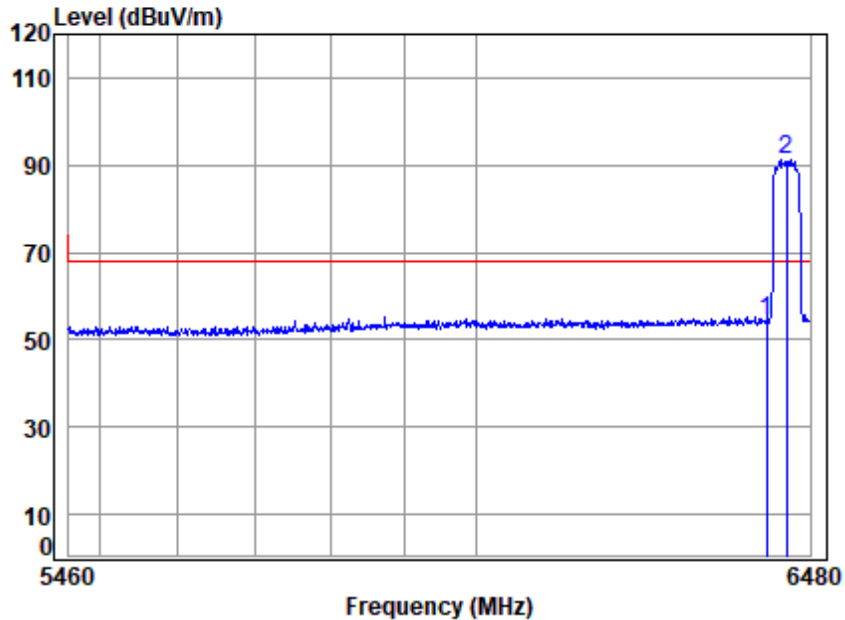

Site : chamber  
 Condition: 3m HORIZONTAL  
 Job No : 00384AT/00385AT  
 Mode : 6445 Band edge  
 : 5G WIFI 11AX40

	Cable	Ant	Preamp	Read	Limit	Over	
Freq	Loss	Factor	Factor	Level	Level	Line	Limit Remark
MHz	dB	dB/m	dB	dBuV	dBuV/m	dBuV/m	dB
1 6415.000	8.50	35.29	35.19	45.72	54.32	68.20	-13.88 peak
2 p 6445.000	8.52	35.47	35.21	82.33	91.11	68.20	22.91 peak



Unless otherwise agreed in writing, this document is issued by the Company subject to its General Conditions of Service printed overleaf, available on request or accessible at <https://www.sgs.com/en/Terms-and-Conditions>. Attention is drawn to the limitation of liability, indemnification and jurisdiction issues defined therein. Any holder of this document is advised that information contained hereon reflects the Company's findings at the time of its intervention only and within the limits of Client's instructions, if any. The Company's sole responsibility is to its Client and this document does not exonerate parties to a transaction from exercising all their rights and obligations under the transaction documents. This document cannot be reproduced except in full, without prior written approval of the Company. Any unauthorized alteration, forgery or falsification of the content or appearance of this document is unlawful and offenders may be prosecuted to the fullest extent of the law. Unless otherwise stated the results shown in this test report refer only to the sample(s) tested and such sample(s) are retained for 30 days only.

Attention: To check the authenticity of testing /inspection report & certificate, please contact us at telephone: (86-755) 8307 1443, or email: CN.Doccheck@sgs.com  
 No.1 Workshop, M-10, Middle Section, Science & Technology Park, Nanshan District, Shenzhen, Guangdong, China 518057 t (86-755) 26012053 f (86-755) 26710594 www.sgs.com.cn  
 中国·广东·深圳市南山区科技园中区M-10栋1号厂房 邮编: 518057 t (86-755) 26012053 f (86-755) 26710594 sgs.china@sgs.com

Polarity: Vertical; Modulation:802.11ax(Full RU0); Bandwidth:40MHz; Channel:Low

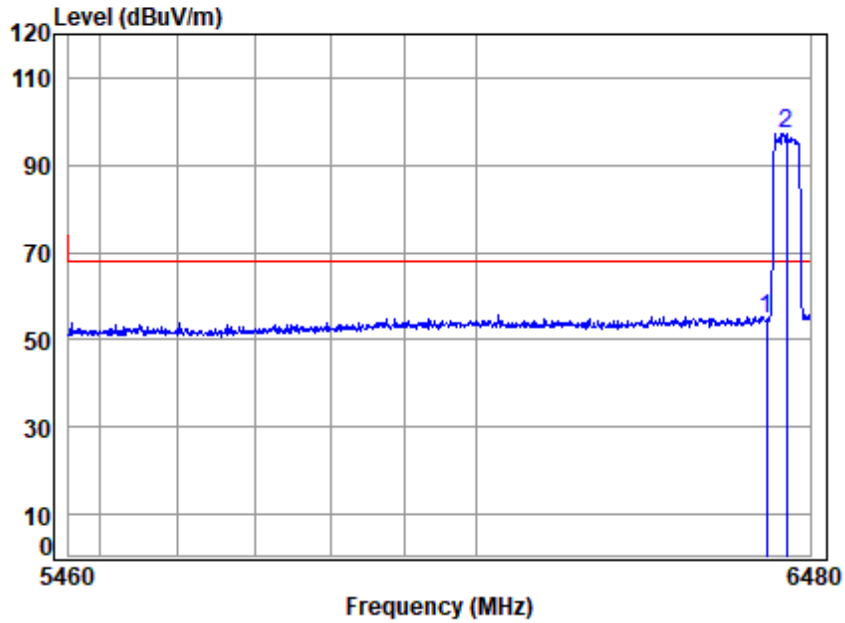

Site : chamber  
 Condition: 3m VERTICAL  
 Job No : 00384AT/00385AT  
 Mode : 6445 Band edge  
 : 5G WIFI 11AX40

	Cable	Ant	Preamp	Read	Limit	Over	
Freq	Loss	Factor	Factor	Level	Level	Line	Limit Remark
MHz	dB	dB/m	dB	dBuV	dBuV/m	dBuV/m	dB
1 6415.000	8.50	35.29	35.19	46.14	54.74	68.20	-13.46 peak
2 p 6445.000	8.52	35.47	35.21	88.42	97.20	68.20	29.00 peak



Unless otherwise agreed in writing, this document is issued by the Company subject to its General Conditions of Service printed overleaf, available on request or accessible at <https://www.sgs.com/en/Terms-and-Conditions>. Attention is drawn to the limitation of liability, indemnification and jurisdiction issues defined therein. Any holder of this document is advised that information contained hereon reflects the Company's findings at the time of its intervention only and within the limits of Client's instructions, if any. The Company's sole responsibility is to its Client and this document does not exonerate parties to a transaction from exercising all their rights and obligations under the transaction documents. This document cannot be reproduced except in full, without prior written approval of the Company. Any unauthorized alteration, forgery or falsification of the content or appearance of this document is unlawful and offenders may be prosecuted to the fullest extent of the law. Unless otherwise stated the results shown in this test report refer only to the sample(s) tested and such sample(s) are retained for 30 days only.



Polarity: Horizontal; Modulation:802.11ax(Full RU0); Bandwidth:40MHz; Channel:High

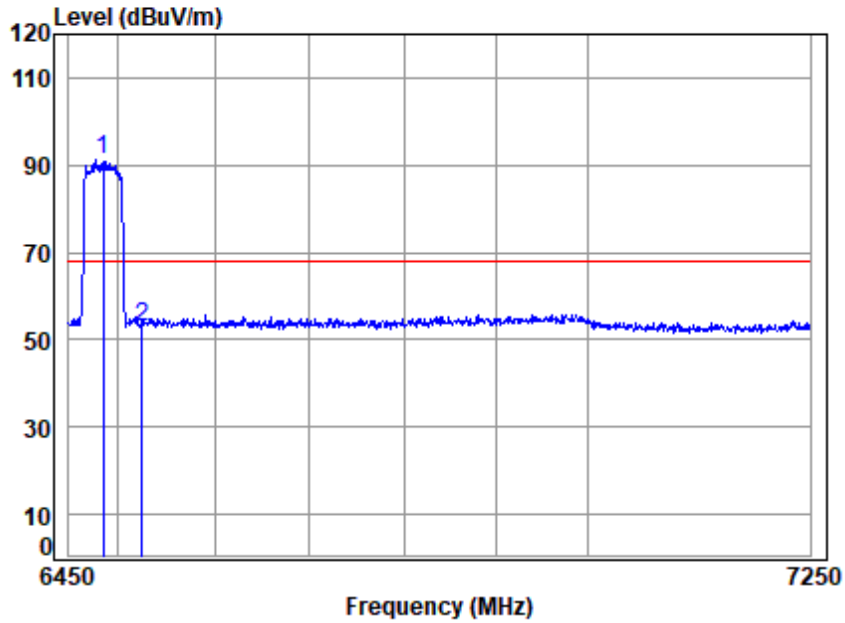

Site : chamber  
 Condition: 3m HORIZONTAL  
 Job No : 00384AT/00385AT  
 Mode : 6485 Band edge  
 : 5G WIFI 11AX40

	Cable	Ant	Preamp	Read	Limit	Over	
Freq	Loss	Factor	Factor	Level	Level	Line	Limit Remark
MHz	dB	dB/m	dB	dBuV	dBuV/m	dBuV/m	dB
1 p 6485.000	8.55	35.57	35.24	82.22	91.10	68.20	22.90 peak
2 6525.000	8.58	35.55	35.26	44.26	53.13	68.20	-15.07 peak



Unless otherwise agreed in writing, this document is issued by the Company subject to its General Conditions of Service printed overleaf, available on request or accessible at <https://www.sgs.com/en/Terms-and-Conditions>. Attention is drawn to the limitation of liability, indemnification and jurisdiction issues defined therein. Any holder of this document is advised that information contained hereon reflects the Company's findings at the time of its intervention only and within the limits of Client's instructions, if any. The Company's sole responsibility is to its Client and this document does not exonerate parties to a transaction from exercising all their rights and obligations under the transaction documents. This document cannot be reproduced except in full, without prior written approval of the Company. Any unauthorized alteration, forgery or falsification of the content or appearance of this document is unlawful and offenders may be prosecuted to the fullest extent of the law. Unless otherwise stated the results shown in this test report refer only to the sample(s) tested and such sample(s) are retained for 30 days only.

Attention: To check the authenticity of testing /inspection report & certificate, please contact us at telephone: (86-755) 8307 1443, or email: CN.Doccheck@sgs.com  
 No.1 Workshop, M-10, Middle Section, Science & Technology Park, Nanshan District, Shenzhen, Guangdong, China 518057 t (86-755) 26012053 f (86-755) 26710594 www.sgs.com.cn  
 中国·广东·深圳市南山区科技园中区M-10栋1号厂房 邮编: 518057 t (86-755) 26012053 f (86-755) 26710594 sgs.china@sgs.com

Polarity: Vertical; Modulation:802.11ax(Full RU0); Bandwidth:40MHz; Channel:High

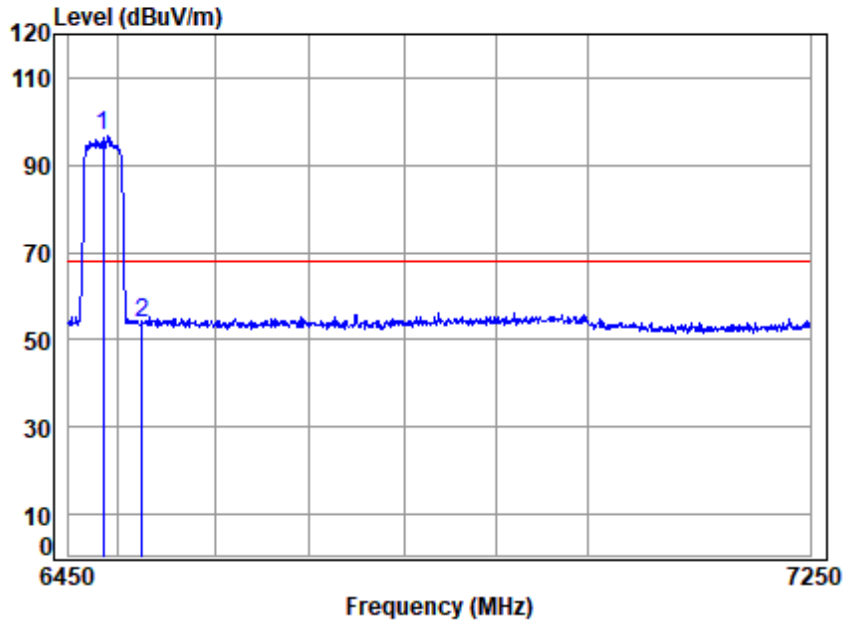

Site : chamber  
 Condition: 3m VERTICAL  
 Job No : 00384AT/00385AT  
 Mode : 6485 Band edge  
 : 5G WIFI 11AX40

	Cable	Ant	Preamp	Read	Limit	Over	
Freq	Loss	Factor	Factor	Level	Level	Line	Limit Remark
MHz	dB	dB/m	dB	dBuV	dBuV/m	dBuV/m	dB
1 p 6485.000	8.55	35.57	35.24	87.94	96.82	68.20	28.62 peak
2 6525.000	8.58	35.55	35.26	44.86	53.73	68.20	-14.47 peak



Unless otherwise agreed in writing, this document is issued by the Company subject to its General Conditions of Service printed overleaf, available on request or accessible at <https://www.sgs.com/en/Terms-and-Conditions>. Attention is drawn to the limitation of liability, indemnification and jurisdiction issues defined therein. Any holder of this document is advised that information contained hereon reflects the Company's findings at the time of its intervention only and within the limits of Client's instructions, if any. The Company's sole responsibility is to its Client and this document does not exonerate parties to a transaction from exercising all their rights and obligations under the transaction documents. This document cannot be reproduced except in full, without prior written approval of the Company. Any unauthorized alteration, forgery or falsification of the content or appearance of this document is unlawful and offenders may be prosecuted to the fullest extent of the law. Unless otherwise stated the results shown in this test report refer only to the sample(s) tested and such sample(s) are retained for 30 days only.

Attention: To check the authenticity of testing /inspection report & certificate, please contact us at telephone: (86-755) 8307 1443, or email: CN.Doccheck@sgs.com  
 No.1 Workshop, M-10, Middle Section, Science & Technology Park, Nanshan District, Shenzhen, Guangdong, China 518057 t (86-755) 26012053 f (86-755) 26710594 www.sgsgroup.com.cn  
 中国·广东·深圳市南山区科技园中区M-10栋1号厂房 邮编: 518057 t (86-755) 26012053 f (86-755) 26710594 sgs.china@sgs.com

Polarity: Horizontal; Modulation:802.11ax(Full RU0); Bandwidth:80MHz; Channel:middle

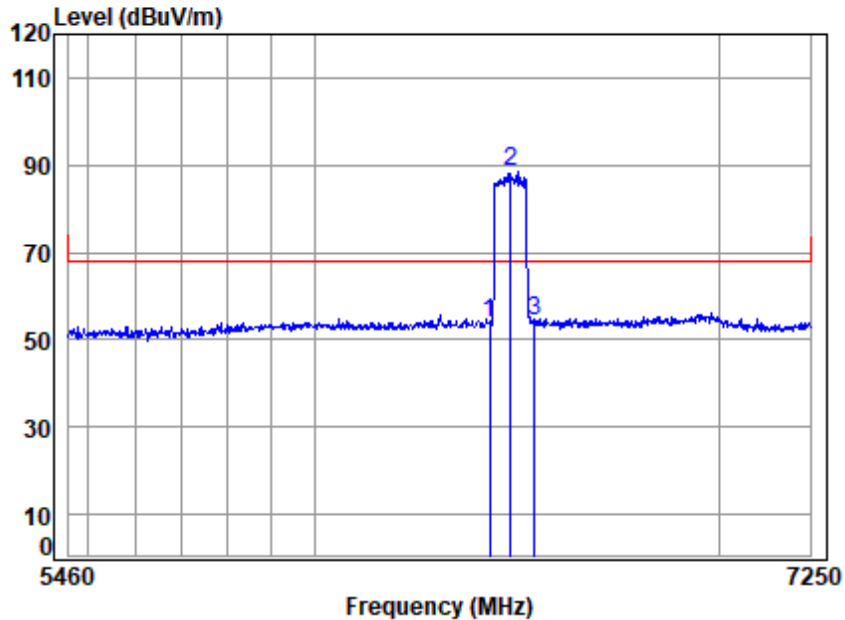

Site : chamber  
 Condition: 3m HORIZONTAL  
 Job No : 00384AT/00385AT  
 Mode : 6465 Band edge  
 : 5G WIFI 11AX80

		Cable	Ant	Preamp	Read	Limit	Over	
	Freq	Loss	Factor	Factor	Level	Line	Limit	Remark
	MHz	dB	dB/m	dB	dBuV	dBuV/m	dBuV/m	dB
1	6415.000	8.50	35.29	35.19	45.36	53.96	68.20	-14.24 peak
2 p	6465.000	8.53	35.53	35.22	79.72	88.56	68.20	20.36 peak
3	6525.000	8.58	35.55	35.26	45.52	54.39	68.20	-13.81 peak



Unless otherwise agreed in writing, this document is issued by the Company subject to its General Conditions of Service printed overleaf, available on request or accessible at <https://www.sgs.com/en/Terms-and-Conditions>. Attention is drawn to the limitation of liability, indemnification and jurisdiction issues defined therein. Any holder of this document is advised that information contained hereon reflects the Company's findings at the time of its intervention only and within the limits of Client's instructions, if any. The Company's sole responsibility is to its Client and this document does not exonerate parties to a transaction from exercising all their rights and obligations under the transaction documents. This document cannot be reproduced except in full, without prior written approval of the Company. Any unauthorized alteration, forgery or falsification of the content or appearance of this document is unlawful and offenders may be prosecuted to the fullest extent of the law. Unless otherwise stated the results shown in this test report refer only to the sample(s) tested and such sample(s) are retained for 30 days only.

Attention: To check the authenticity of testing /inspection report & certificate, please contact us at telephone: (86-755) 8307 1443, or email: CN.Doccheck@sgs.com  
 No.1 Workshop, M-10, Middle Section, Science & Technology Park, Nanshan District, Shenzhen, Guangdong, China 518057 t (86-755) 26012053 f (86-755) 26710594 www.sgsgroup.com.cn  
 中国·广东·深圳市南山区科技园中区M-10栋1号厂房 邮编: 518057 t (86-755) 26012053 f (86-755) 26710594 sgs.china@sgs.com

Polarity: Vertical; Modulation:802.11ax(Full RU0); Bandwidth:80MHz; Channel:middle

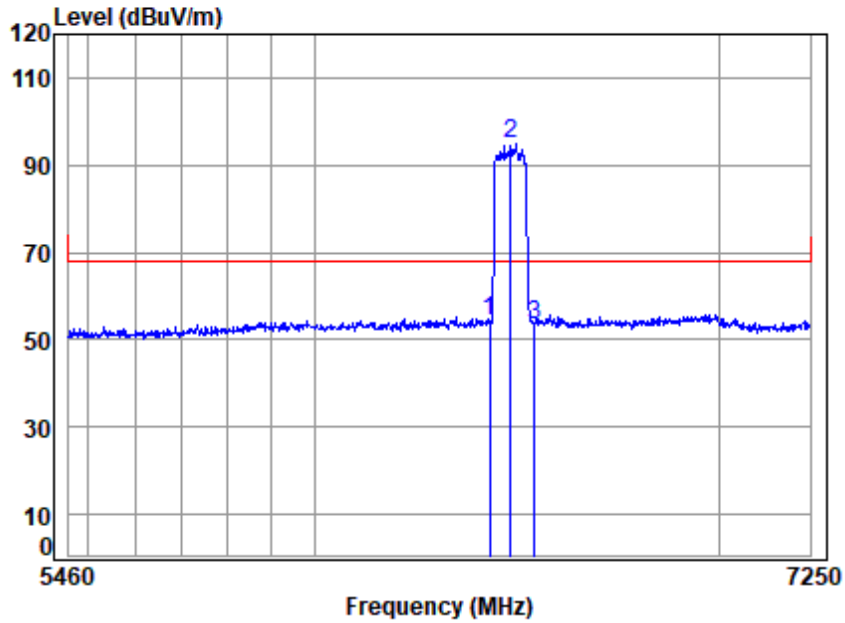

Site : chamber  
 Condition: 3m VERTICAL  
 Job No : 00384AT/00385AT  
 Mode : 6465 Band edge  
 : 5G WIFI 11AX80

		Cable	Ant	Preamp	Read	Limit	Over	
	Freq	Loss	Factor	Factor	Level	Line	Limit	Remark
	MHz	dB	dB/m	dB	dBuV	dBuV/m	dBuV/m	dB
1	6415.000	8.50	35.29	35.19	45.72	54.32	68.20	-13.88 peak
2 p	6465.000	8.53	35.53	35.22	85.87	94.71	68.20	26.51 peak
3	6525.000	8.58	35.55	35.26	44.69	53.56	68.20	-14.64 peak



Unless otherwise agreed in writing, this document is issued by the Company subject to its General Conditions of Service printed overleaf, available on request or accessible at <https://www.sgs.com/en/Terms-and-Conditions>. Attention is drawn to the limitation of liability, indemnification and jurisdiction issues defined therein. Any holder of this document is advised that information contained hereon reflects the Company's findings at the time of its intervention only and within the limits of Client's instructions, if any. The Company's sole responsibility is to its Client and this document does not exonerate parties to a transaction from exercising all their rights and obligations under the transaction documents. This document cannot be reproduced except in full, without prior written approval of the Company. Any unauthorized alteration, forgery or falsification of the content or appearance of this document is unlawful and offenders may be prosecuted to the fullest extent of the law. Unless otherwise stated the results shown in this test report refer only to the sample(s) tested and such sample(s) are retained for 30 days only.



Polarity: Horizontal; Modulation:802.11ax(Full RU0); Bandwidth:20MHz; Channel:Low

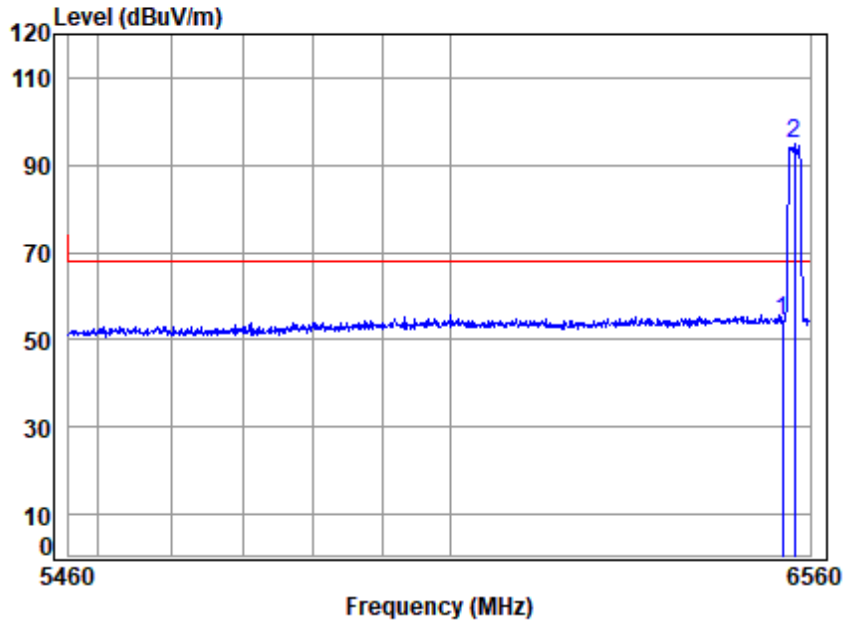

Site : chamber  
 Condition: 3m HORIZONTAL  
 Job No : 00384AT/00385AT  
 Mode : 6535 Band edge  
 : 5G WIFI 11AX20

	Cable	Ant	Preamp	Read	Limit	Over	
Freq	Loss	Factor	Factor	Level	Level	Line	Limit Remark
MHz	dB	dB/m	dB	dBuV	dBuV/m	dBuV/m	dB
1	6515.000	8.57	35.57	35.26	45.28	54.16	68.20 -14.04 peak
2 p	6535.000	8.59	35.53	35.27	86.04	94.89	68.20 26.69 peak



Unless otherwise agreed in writing, this document is issued by the Company subject to its General Conditions of Service printed overleaf, available on request or accessible at <https://www.sgs.com/en/Terms-and-Conditions>. Attention is drawn to the limitation of liability, indemnification and jurisdiction issues defined therein. Any holder of this document is advised that information contained hereon reflects the Company's findings at the time of its intervention only and within the limits of Client's instructions, if any. The Company's sole responsibility is to its Client and this document does not exonerate parties to a transaction from exercising all their rights and obligations under the transaction documents. This document cannot be reproduced except in full, without prior written approval of the Company. Any unauthorized alteration, forgery or falsification of the content or appearance of this document is unlawful and offenders may be prosecuted to the fullest extent of the law. Unless otherwise stated the results shown in this test report refer only to the sample(s) tested and such sample(s) are retained for 30 days only.

Attention: To check the authenticity of testing /inspection report & certificate, please contact us at telephone: (86-755) 8307 1443, or email: CN.Doccheck@sgs.com

No.1 Workshop, M-10, Middle Section, Science & Technology Park, Nanshan District, Shenzhen, Guangdong, China 518057 t (86-755) 26012053 f (86-755) 26710594 www.sgsgroup.com.cn  
 中国·广东·深圳市南山区科技园中区M-10栋1号厂房 邮编: 518057 t (86-755) 26012053 f (86-755) 26710594 sgs.china@sgs.com

Polarity: Vertical; Modulation:802.11ax(Full RU0); Bandwidth:20MHz; Channel:Low

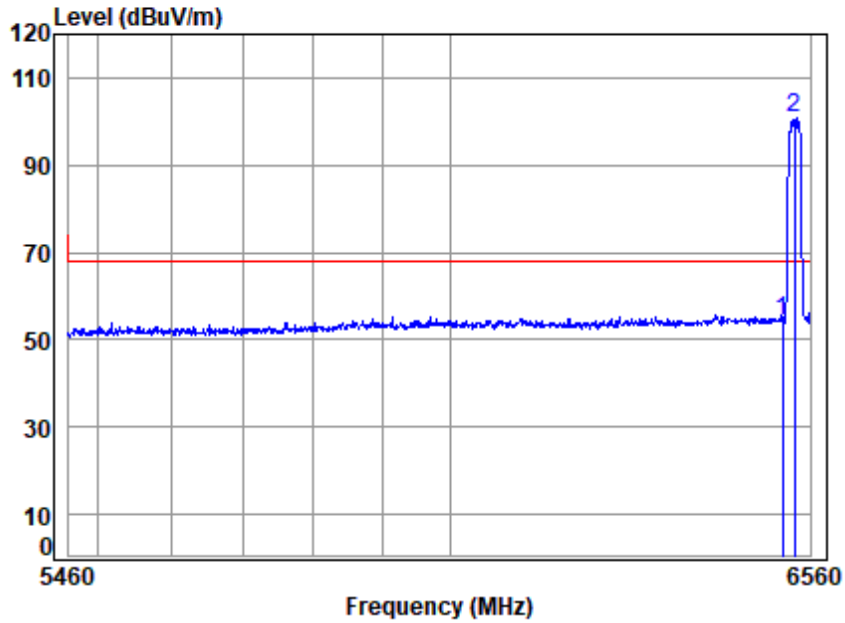

Site : chamber  
 Condition: 3m VERTICAL  
 Job No : 00384AT/00385AT  
 Mode : 6535 Band edge  
 : 5G WIFI 11AX20

	Cable	Ant	Preamp	Read	Limit	Over	
Freq	Loss	Factor	Factor	Level	Level	Line	Limit Remark
MHz	dB	dB/m	dB	dBuV	dBuV/m	dBuV/m	dB
1	6515.000	8.57	35.57	35.26	45.27	54.15	68.20 -14.05 peak
2 p	6535.000	8.59	35.53	35.27	91.86	100.71	68.20 32.51 peak



Unless otherwise agreed in writing, this document is issued by the Company subject to its General Conditions of Service printed overleaf, available on request or accessible at <https://www.sgs.com/en/Terms-and-Conditions>. Attention is drawn to the limitation of liability, indemnification and jurisdiction issues defined therein. Any holder of this document is advised that information contained hereon reflects the Company's findings at the time of its intervention only and within the limits of Client's instructions, if any. The Company's sole responsibility is to its Client and this document does not exonerate parties to a transaction from exercising all their rights and obligations under the transaction documents. This document cannot be reproduced except in full, without prior written approval of the Company. Any unauthorized alteration, forgery or falsification of the content or appearance of this document is unlawful and offenders may be prosecuted to the fullest extent of the law. Unless otherwise stated the results shown in this test report refer only to the sample(s) tested and such sample(s) are retained for 30 days only.

Attention: To check the authenticity of testing /inspection report & certificate, please contact us at telephone: (86-755) 8307 1443, or email: CN.Doccheck@sgs.com

No.1 Workshop, M-10, Middle Section, Science & Technology Park, Nanshan District, Shenzhen, Guangdong, China 518057 t (86-755) 26012053 f (86-755) 26710594 www.sgs.com.cn  
 中国·广东·深圳市南山区科技园中区M-10栋1号厂房 邮编: 518057 t (86-755) 26012053 f (86-755) 26710594 sgs.china@sgs.com

Polarity: Horizontal; Modulation:802.11ax(Full RU0); Bandwidth:20MHz; Channel:High

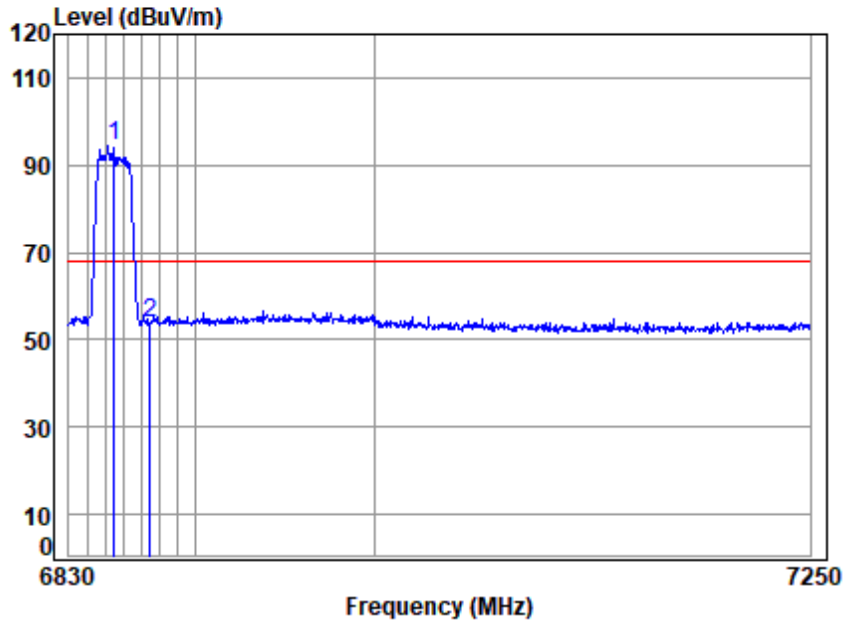

Site : chamber  
 Condition: 3m HORIZONTAL  
 Job No : 00384AT/00385AT  
 Mode : 6855 Band edge  
 : 5G WIFI 11AX20

	Cable	Ant	Preamp	Read	Limit	Over	
Freq	Loss	Factor	Factor	Level	Level	Line	Limit Remark
MHz	dB	dB/m	dB	dBuV	dBuV/m	dBuV/m	dB
1 p 6855.000	8.82	35.51	35.48	85.61	94.46	68.20	26.26 peak
2 6875.000	8.83	35.55	35.49	44.73	53.62	68.20	-14.58 peak



Unless otherwise agreed in writing, this document is issued by the Company subject to its General Conditions of Service printed overleaf, available on request or accessible at <https://www.sgs.com/en/Terms-and-Conditions>. Attention is drawn to the limitation of liability, indemnification and jurisdiction issues defined therein. Any holder of this document is advised that information contained hereon reflects the Company's findings at the time of its intervention only and within the limits of Client's instructions, if any. The Company's sole responsibility is to its Client and this document does not exonerate parties to a transaction from exercising all their rights and obligations under the transaction documents. This document cannot be reproduced except in full, without prior written approval of the Company. Any unauthorized alteration, forgery or falsification of the content or appearance of this document is unlawful and offenders may be prosecuted to the fullest extent of the law. Unless otherwise stated the results shown in this test report refer only to the sample(s) tested and such sample(s) are retained for 30 days only.

Attention: To check the authenticity of testing /inspection report & certificate, please contact us at telephone: (86-755) 8307 1443, or email: CN.Doccheck@sgs.com  
 No.1 Workshop, M-10, Middle Section, Science & Technology Park, Nanshan District, Shenzhen, Guangdong, China 518057 t (86-755) 26012053 f (86-755) 26710594 www.sgsgroup.com.cn  
 中国·广东·深圳市南山区科技园中区M-10栋1号厂房 邮编: 518057 t (86-755) 26012053 f (86-755) 26710594 sgs.china@sgs.com

Polarity: Vertical; Modulation:802.11ax(Full RU0); Bandwidth:20MHz; Channel:High

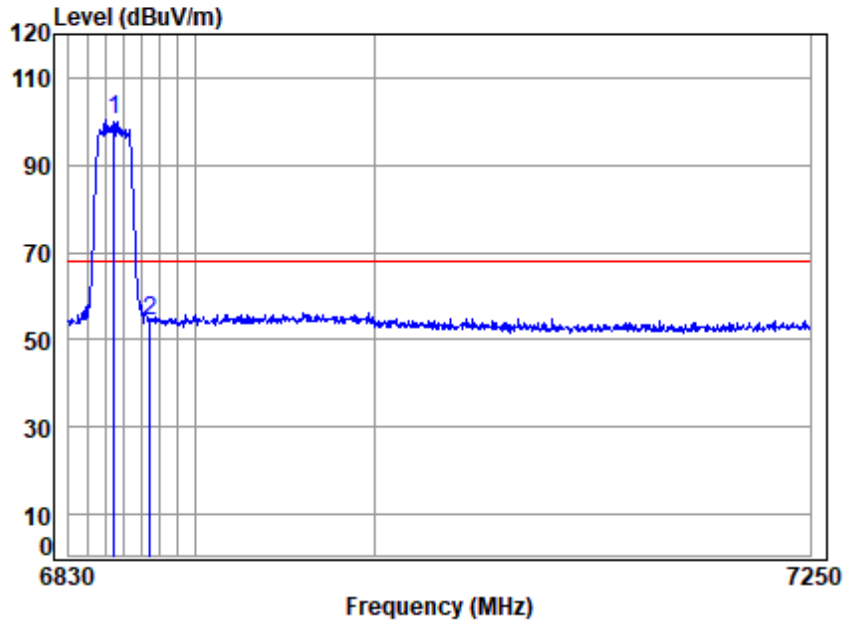

Site : chamber  
 Condition: 3m VERTICAL  
 Job No : 00384AT/00385AT  
 Mode : 6855 Band edge  
 : 5G WIFI 11AX20

	Cable	Ant	Preamp	Read	Limit	Over	
Freq	Loss	Factor	Factor	Level	Level	Line	Limit Remark
MHz	dB	dB/m	dB	dBuV	dBuV/m	dBuV/m	dB
1 p 6855.000	8.82	35.51	35.48	91.34	100.19	68.20	31.99 peak
2 6875.000	8.83	35.55	35.49	45.32	54.21	68.20	-13.99 peak



Unless otherwise agreed in writing, this document is issued by the Company subject to its General Conditions of Service printed overleaf, available on request or accessible at <https://www.sgs.com/en/Terms-and-Conditions>. Attention is drawn to the limitation of liability, indemnification and jurisdiction issues defined therein. Any holder of this document is advised that information contained hereon reflects the Company's findings at the time of its intervention only and within the limits of Client's instructions, if any. The Company's sole responsibility is to its Client and this document does not exonerate parties to a transaction from exercising all their rights and obligations under the transaction documents. This document cannot be reproduced except in full, without prior written approval of the Company. Any unauthorized alteration, forgery or falsification of the content or appearance of this document is unlawful and offenders may be prosecuted to the fullest extent of the law. Unless otherwise stated the results shown in this test report refer only to the sample(s) tested and such sample(s) are retained for 30 days only.

Attention: To check the authenticity of testing /inspection report & certificate, please contact us at telephone: (86-755) 8307 1443, or email: CN.Doccheck@sgs.com  
 No.1 Workshop, M-10, Middle Section, Science & Technology Park, Nanshan District, Shenzhen, Guangdong, China 518057 t (86-755) 26012053 f (86-755) 26710594 www.sgs.com.cn  
 中国·广东·深圳市南山区科技园中区M-10栋1号厂房 邮编: 518057 t (86-755) 26012053 f (86-755) 26710594 sgs.china@sgs.com



Polarity: Horizontal; Modulation:802.11ax(Full RU0); Bandwidth:40MHz; Channel:Low

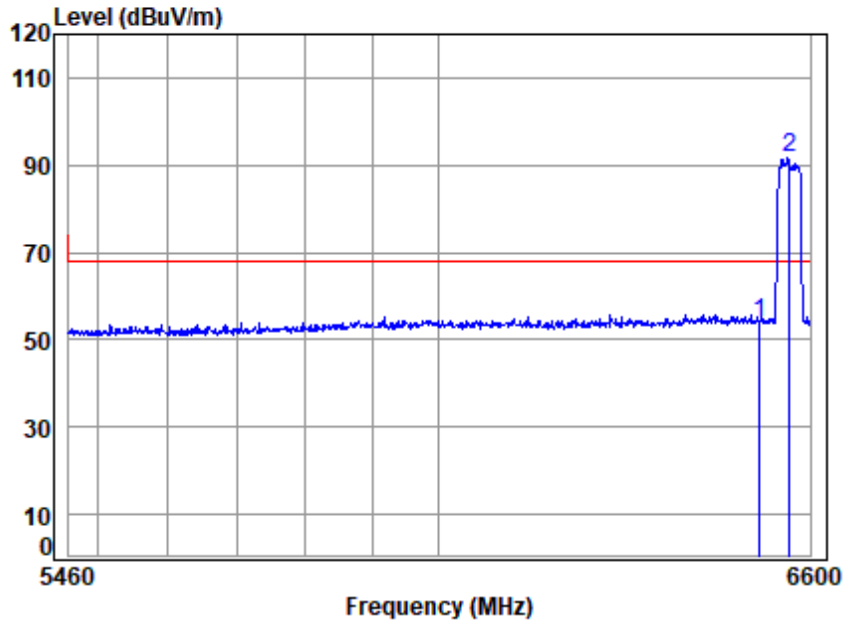

Site : chamber  
 Condition: 3m HORIZONTAL  
 Job No : 00384AT/00385AT  
 Mode : 6565 Band edge  
 : 5G WIFI 11AX40

	Cable	Ant	Preamp	Read	Limit	Over	
Freq	Loss	Factor	Factor	Level	Level	Line	Limit Remark
MHz	dB	dB/m	dB	dBuV	dBuV/m	dBuV/m	dB
1 6515.000	8.57	35.57	35.26	44.93	53.81	68.20	-14.39 peak
2 p 6565.000	8.61	35.44	35.29	82.84	91.60	68.20	23.40 peak



Unless otherwise agreed in writing, this document is issued by the Company subject to its General Conditions of Service printed overleaf, available on request or accessible at <https://www.sgs.com/en/Terms-and-Conditions>. Attention is drawn to the limitation of liability, indemnification and jurisdiction issues defined therein. Any holder of this document is advised that information contained hereon reflects the Company's findings at the time of its intervention only and within the limits of Client's instructions, if any. The Company's sole responsibility is to its Client and this document does not exonerate parties to a transaction from exercising all their rights and obligations under the transaction documents. This document cannot be reproduced except in full, without prior written approval of the Company. Any unauthorized alteration, forgery or falsification of the content or appearance of this document is unlawful and offenders may be prosecuted to the fullest extent of the law. Unless otherwise stated the results shown in this test report refer only to the sample(s) tested and such sample(s) are retained for 30 days only.

Attention: To check the authenticity of testing /inspection report & certificate, please contact us at telephone: (86-755) 8307 1443, or email: CN.Doccheck@sgs.com

No.1 Workshop, M-10, Middle Section, Science & Technology Park, Nanshan District, Shenzhen, Guangdong, China 518057 t (86-755) 26012053 f (86-755) 26710594 www.sgsgroup.com.cn  
 中国·广东·深圳市南山区科技园中区M-10栋1号厂房 邮编: 518057 t (86-755) 26012053 f (86-755) 26710594 sgs.china@sgs.com

Polarity: Vertical; Modulation:802.11ax(Full RU0); Bandwidth:40MHz; Channel:Low

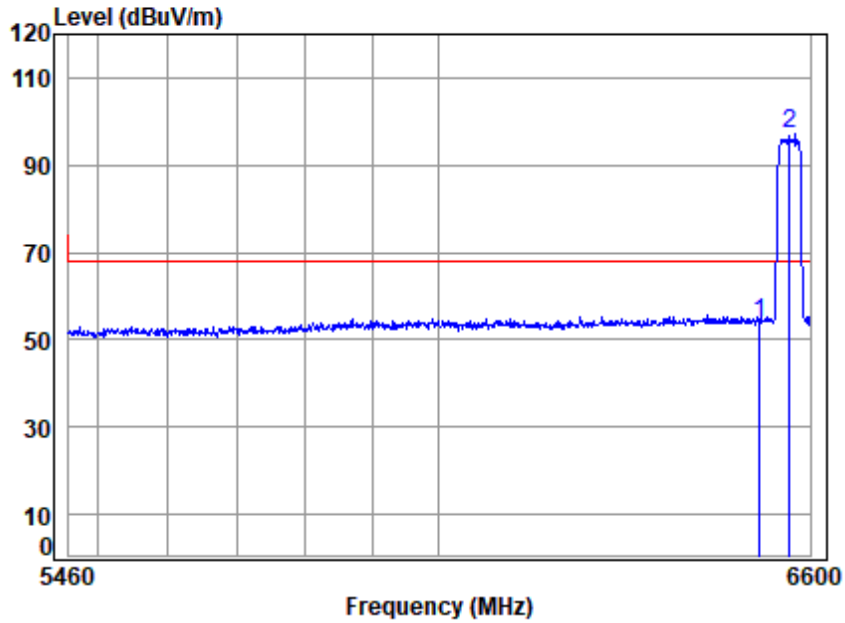

Site : chamber  
 Condition: 3m VERTICAL  
 Job No : 00384AT/00385AT  
 Mode : 6565 Band edge  
 : 5G WIFI 11AX40

	Cable	Ant	Preamp	Read	Limit	Over	
Freq	Loss	Factor	Factor	Level	Level	Line	Limit Remark
MHz	dB	dB/m	dB	dBuV	dBuV/m	dBuV/m	dB
1 6515.000	8.57	35.57	35.26	45.14	54.02	68.20	-14.18 peak
2 p 6565.000	8.61	35.44	35.29	88.57	97.33	68.20	29.13 peak



Unless otherwise agreed in writing, this document is issued by the Company subject to its General Conditions of Service printed overleaf, available on request or accessible at <https://www.sgs.com/en/Terms-and-Conditions>. Attention is drawn to the limitation of liability, indemnification and jurisdiction issues defined therein. Any holder of this document is advised that information contained hereon reflects the Company's findings at the time of its intervention only and within the limits of Client's instructions, if any. The Company's sole responsibility is to its Client and this document does not exonerate parties to a transaction from exercising all their rights and obligations under the transaction documents. This document cannot be reproduced except in full, without prior written approval of the Company. Any unauthorized alteration, forgery or falsification of the content or appearance of this document is unlawful and offenders may be prosecuted to the fullest extent of the law. Unless otherwise stated the results shown in this test report refer only to the sample(s) tested and such sample(s) are retained for 30 days only.

Attention: To check the authenticity of testing /inspection report & certificate, please contact us at telephone: (86-755) 8307 1443, or email: CN.Doccheck@sgs.com

No.1 Workshop, M-10, Middle Section, Science & Technology Park, Nanshan District, Shenzhen, Guangdong, China 518057 t (86-755) 26012053 f (86-755) 26710594 www.sgsgroup.com.cn  
 中国·广东·深圳市南山区科技园中区M-10栋1号厂房 邮编: 518057 t (86-755) 26012053 f (86-755) 26710594 sgs.china@sgs.com

Polarity: Horizontal; Modulation:802.11ax(Full RU0); Bandwidth:40MHz; Channel:High

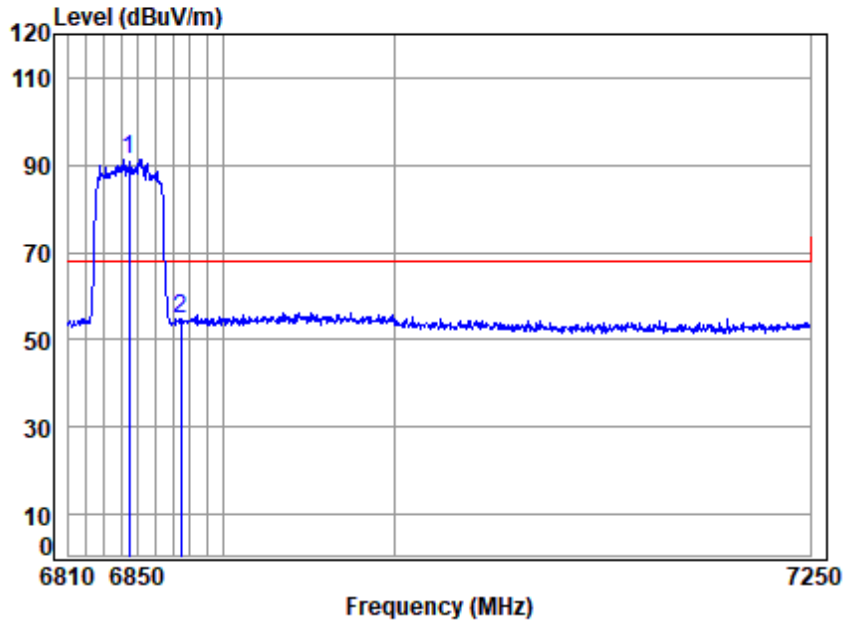

Site : chamber  
 Condition: 3m HORIZONTAL  
 Job No : 00384AT/00385AT  
 Mode : 6845 Band edge  
 : 5G WIFI 11AX40

	Cable	Ant	Preamp	Read	Limit	Over	
Freq	Loss	Factor	Factor	Level	Level	Line	Limit Remark
MHz	dB	dB/m	dB	dBuV	dBuV/m	dBuV/m	dB
1 p 6845.000	8.81	35.48	35.47	82.40	91.22	68.20	23.02 peak
2 6875.000	8.83	35.55	35.49	45.64	54.53	68.20	-13.67 peak



Unless otherwise agreed in writing, this document is issued by the Company subject to its General Conditions of Service printed overleaf, available on request or accessible at <https://www.sgs.com/en/Terms-and-Conditions>. Attention is drawn to the limitation of liability, indemnification and jurisdiction issues defined therein. Any holder of this document is advised that information contained hereon reflects the Company's findings at the time of its intervention only and within the limits of Client's instructions, if any. The Company's sole responsibility is to its Client and this document does not exonerate parties to a transaction from exercising all their rights and obligations under the transaction documents. This document cannot be reproduced except in full, without prior written approval of the Company. Any unauthorized alteration, forgery or falsification of the content or appearance of this document is unlawful and offenders may be prosecuted to the fullest extent of the law. Unless otherwise stated the results shown in this test report refer only to the sample(s) tested and such sample(s) are retained for 30 days only.

Attention: To check the authenticity of testing /inspection report & certificate, please contact us at telephone: (86-755) 8307 1443, or email: CN.Doccheck@sgs.com  
 No.1 Workshop, M-10, Middle Section, Science & Technology Park, Nanshan District, Shenzhen, Guangdong, China 518057 t (86-755) 26012053 f (86-755) 26710594 www.sgs.com.cn  
 中国·广东·深圳市南山区科技园中区M-10栋1号厂房 邮编: 518057 t (86-755) 26012053 f (86-755) 26710594 sgs.china@sgs.com

Polarity: Vertical; Modulation:802.11ax(Full RU0); Bandwidth:40MHz; Channel:High

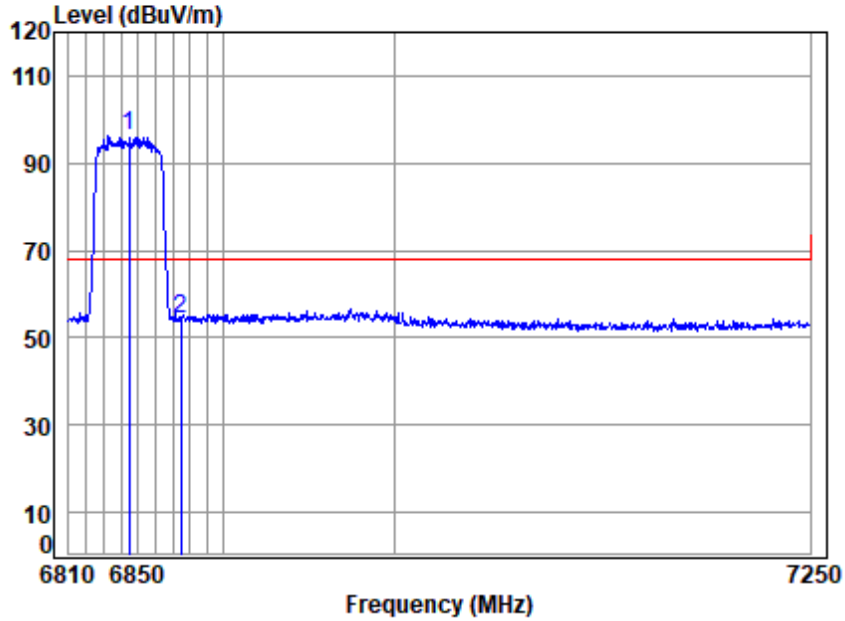

Site : chamber  
 Condition: 3m VERTICAL  
 Job No : 00384AT/00385AT  
 Mode : 6845 Band edge  
 : 5G WIFI 11AX40

	Cable	Ant	Preamp	Read	Limit	Over	
Freq	Loss	Factor	Factor	Level	Level	Line	Limit Remark
MHz	dB	dB/m	dB	dBuV	dBuV/m	dBuV/m	dB
1 p 6845.000	8.81	35.48	35.47	87.25	96.07	68.20	27.87 peak
2 6875.000	8.83	35.55	35.49	45.36	54.25	68.20	-13.95 peak



Unless otherwise agreed in writing, this document is issued by the Company subject to its General Conditions of Service printed overleaf, available on request or accessible at <https://www.sgs.com/en/Terms-and-Conditions>. Attention is drawn to the limitation of liability, indemnification and jurisdiction issues defined therein. Any holder of this document is advised that information contained hereon reflects the Company's findings at the time of its intervention only and within the limits of Client's instructions, if any. The Company's sole responsibility is to its Client and this document does not exonerate parties to a transaction from exercising all their rights and obligations under the transaction documents. This document cannot be reproduced except in full, without prior written approval of the Company. Any unauthorized alteration, forgery or falsification of the content or appearance of this document is unlawful and offenders may be prosecuted to the fullest extent of the law. Unless otherwise stated the results shown in this test report refer only to the sample(s) tested and such sample(s) are retained for 30 days only.

Attention: To check the authenticity of testing /inspection report & certificate, please contact us at telephone: (86-755) 8307 1443, or email: CN.Doccheck@sgs.com  
 No.1 Workshop, M-10, Middle Section, Science & Technology Park, Nanshan District, Shenzhen, Guangdong, China 518057 t (86-755) 26012053 f (86-755) 26710594 www.sgs.com.cn  
 中国·广东·深圳市南山区科技园中区M-10栋1号厂房 邮编: 518057 t (86-755) 26012053 f (86-755) 26710594 sgs.china@sgs.com



Polarity: Horizontal; Modulation:802.11ax(Full RU0); Bandwidth:80MHz; Channel:Low

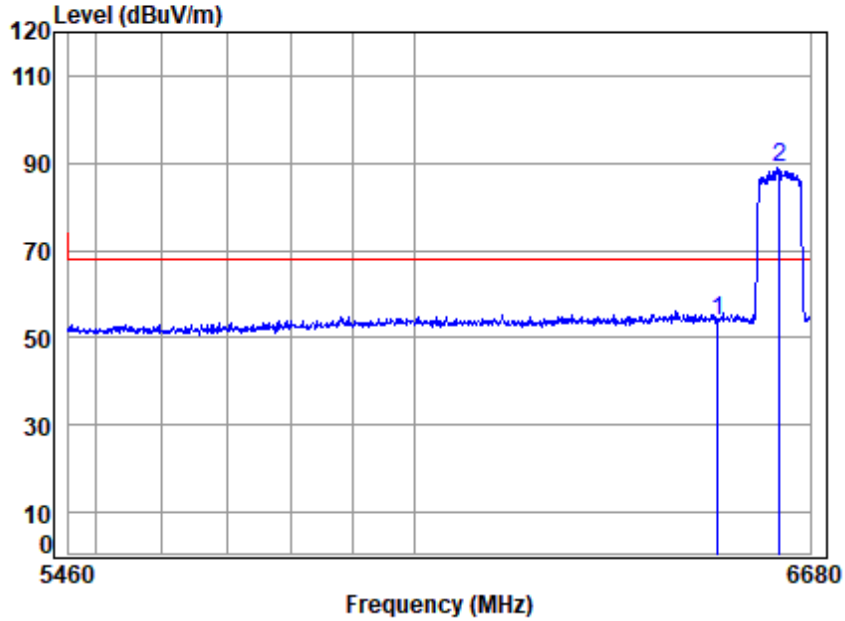

Site : chamber  
 Condition: 3m HORIZONTAL  
 Job No : 00384AT/00385AT  
 Mode : 6625 Band edge  
 : 5G WIFI 11AX80

	Cable	Ant	Preamp	Read	Limit	Over	
Freq	Loss	Factor	Factor	Level	Level	Line	Limit Remark
MHz	dB	dB/m	dB	dBuV	dBuV/m	dBuV/m	dB
1	6515.000	8.57	35.57	35.26	44.75	53.63	68.20 -14.57 peak
2 p	6625.000	8.65	35.25	35.33	80.36	88.93	68.20 20.73 peak



Unless otherwise agreed in writing, this document is issued by the Company subject to its General Conditions of Service printed overleaf, available on request or accessible at <https://www.sgs.com/en/Terms-and-Conditions>. Attention is drawn to the limitation of liability, indemnification and jurisdiction issues defined therein. Any holder of this document is advised that information contained hereon reflects the Company's findings at the time of its intervention only and within the limits of Client's instructions, if any. The Company's sole responsibility is to its Client and this document does not exonerate parties to a transaction from exercising all their rights and obligations under the transaction documents. This document cannot be reproduced except in full, without prior written approval of the Company. Any unauthorized alteration, forgery or falsification of the content or appearance of this document is unlawful and offenders may be prosecuted to the fullest extent of the law. Unless otherwise stated the results shown in this test report refer only to the sample(s) tested and such sample(s) are retained for 30 days only.

Attention: To check the authenticity of testing /inspection report & certificate, please contact us at telephone: (86-755) 8307 1443, or email: CN.Doccheck@sgs.com

No.1 Workshop, M-10, Middle Section, Science & Technology Park, Nanshan District, Shenzhen, Guangdong, China 518057 t (86-755) 26012053 f (86-755) 26710594 www.sgsgroup.com.cn  
 中国·广东·深圳市南山区科技园中区M-10栋1号厂房 邮编: 518057 t (86-755) 26012053 f (86-755) 26710594 sgs.china@sgs.com

Polarity: Vertical; Modulation:802.11ax(Full RU0); Bandwidth:80MHz; Channel:Low

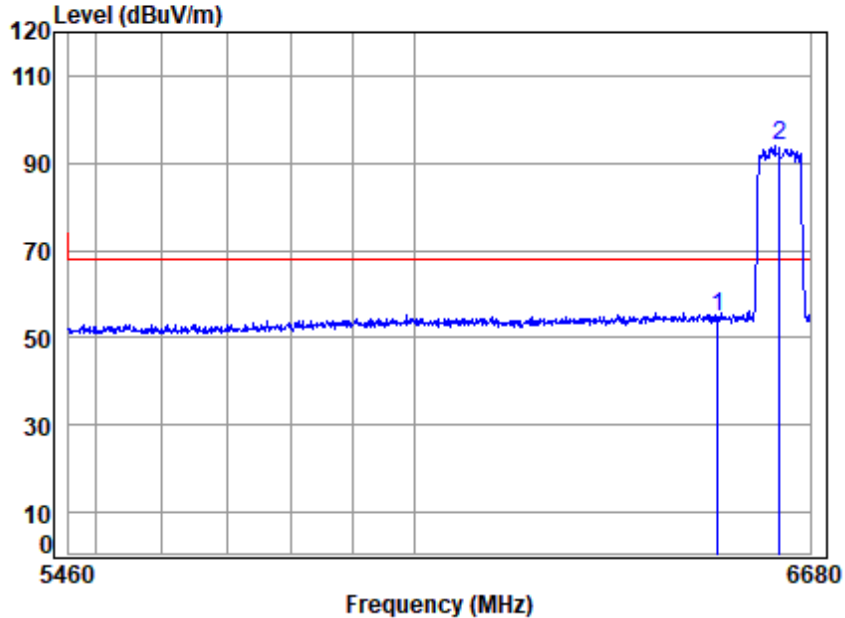

Site : chamber  
 Condition: 3m VERTICAL  
 Job No : 00384AT/00385AT  
 Mode : 6625 Band edge  
 : 5G WIFI 11AX80

	Cable	Ant	Preamp	Read	Limit	Over	
Freq	Loss	Factor	Factor	Level	Level	Line	Limit Remark
MHz	dB	dB/m	dB	dBuV	dBuV/m	dBuV/m	dB
1	6515.000	8.57	35.57	35.26	45.84	54.72	68.20 -13.48 peak
2 p	6625.000	8.65	35.25	35.33	85.63	94.20	68.20 26.00 peak



Unless otherwise agreed in writing, this document is issued by the Company subject to its General Conditions of Service printed overleaf, available on request or accessible at <https://www.sgs.com/en/Terms-and-Conditions>. Attention is drawn to the limitation of liability, indemnification and jurisdiction issues defined therein. Any holder of this document is advised that information contained hereon reflects the Company's findings at the time of its intervention only and within the limits of Client's instructions, if any. The Company's sole responsibility is to its Client and this document does not exonerate parties to a transaction from exercising all their rights and obligations under the transaction documents. This document cannot be reproduced except in full, without prior written approval of the Company. Any unauthorized alteration, forgery or falsification of the content or appearance of this document is unlawful and offenders may be prosecuted to the fullest extent of the law. Unless otherwise stated the results shown in this test report refer only to the sample(s) tested and such sample(s) are retained for 30 days only.

Attention: To check the authenticity of testing /inspection report & certificate, please contact us at telephone: (86-755) 8307 1443, or email: CN.Doccheck@sgs.com  
 No.1 Workshop, M-10, Middle Section, Science & Technology Park, Nanshan District, Shenzhen, Guangdong, China 518057 t (86-755) 26012053 f (86-755) 26710594 www.sgs.com.cn  
 中国·广东·深圳市南山区科技园中区M-10栋1号厂房 邮编: 518057 t (86-755) 26012053 f (86-755) 26710594 sgs.china@sgs.com

Polarity: Horizontal; Modulation:802.11ax(Full RU0); Bandwidth:80MHz; Channel:High

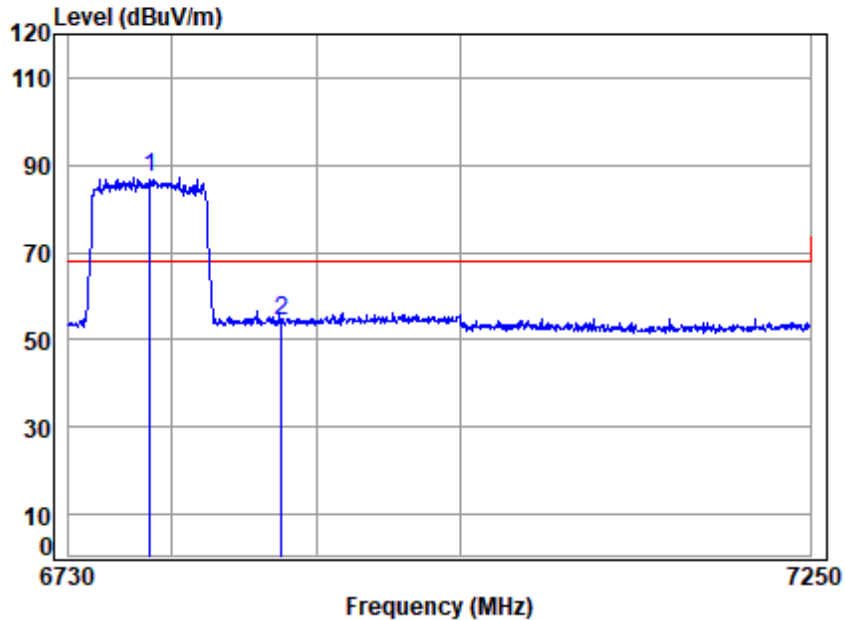

Site : chamber  
 Condition: 3m HORIZONTAL  
 Job No : 00384AT/00385AT  
 Mode : 6785 Band edge  
 : 5G WIFI 11AX80

	Cable	Ant	Preamp	Read	Limit	Over	
Freq	Loss	Factor	Factor	Level	Level	Line	Limit Remark
MHz	dB	dB/m	dB	dBuV	dBuV/m	dBuV/m	dB
1 p 6785.000	8.77	35.27	35.43	78.72	87.33	68.20	19.13 peak
2 6875.000	8.83	35.55	35.49	45.37	54.26	68.20	-13.94 peak



Unless otherwise agreed in writing, this document is issued by the Company subject to its General Conditions of Service printed overleaf, available on request or accessible at <https://www.sgs.com/en/Terms-and-Conditions>. Attention is drawn to the limitation of liability, indemnification and jurisdiction issues defined therein. Any holder of this document is advised that information contained hereon reflects the Company's findings at the time of its intervention only and within the limits of Client's instructions, if any. The Company's sole responsibility is to its Client and this document does not exonerate parties to a transaction from exercising all their rights and obligations under the transaction documents. This document cannot be reproduced except in full, without prior written approval of the Company. Any unauthorized alteration, forgery or falsification of the content or appearance of this document is unlawful and offenders may be prosecuted to the fullest extent of the law. Unless otherwise stated the results shown in this test report refer only to the sample(s) tested and such sample(s) are retained for 30 days only.

Attention: To check the authenticity of testing /inspection report & certificate, please contact us at telephone: (86-755) 8307 1443, or email: CN.Doccheck@sgs.com  
 No.1 Workshop, M-10, Middle Section, Science & Technology Park, Nanshan District, Shenzhen, Guangdong, China 518057 t (86-755) 26012053 f (86-755) 26710594 www.sgs.com.cn  
 中国·广东·深圳市南山区科技园中区M-10栋1号厂房 邮编: 518057 t (86-755) 26012053 f (86-755) 26710594 sgs.china@sgs.com

Polarity: Vertical; Modulation:802.11ax(Full RU0); Bandwidth:80MHz; Channel:High

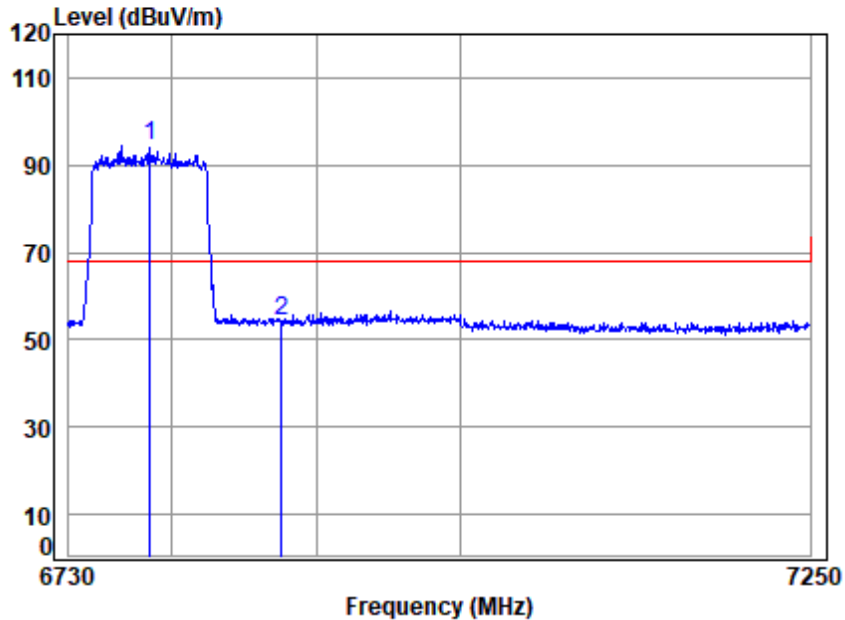

Site : chamber  
 Condition: 3m VERTICAL  
 Job No : 00384AT/00385AT  
 Mode : 6785 Band edge  
 : 5G WIFI 11AX80

	Cable	Ant	Preamp	Read	Limit	Over	
Freq	Loss	Factor	Factor	Level	Level	Line	Limit Remark
MHz	dB	dB/m	dB	dBuV	dBuV/m	dBuV/m	dB
1 p 6785.000	8.77	35.27	35.43	85.61	94.22	68.20	26.02 peak
2 6875.000	8.83	35.55	35.49	45.34	54.23	68.20	-13.97 peak



Unless otherwise agreed in writing, this document is issued by the Company subject to its General Conditions of Service printed overleaf, available on request or accessible at <https://www.sgs.com/en/Terms-and-Conditions>. Attention is drawn to the limitation of liability, indemnification and jurisdiction issues defined therein. Any holder of this document is advised that information contained hereon reflects the Company's findings at the time of its intervention only and within the limits of Client's instructions, if any. The Company's sole responsibility is to its Client and this document does not exonerate parties to a transaction from exercising all their rights and obligations under the transaction documents. This document cannot be reproduced except in full, without prior written approval of the Company. Any unauthorized alteration, forgery or falsification of the content or appearance of this document is unlawful and offenders may be prosecuted to the fullest extent of the law. Unless otherwise stated the results shown in this test report refer only to the sample(s) tested and such sample(s) are retained for 30 days only.

Attention: To check the authenticity of testing /inspection report & certificate, please contact us at telephone: (86-755) 8307 1443, or email: CN.Doccheck@sgs.com

No.1 Workshop, M-10, Middle Section, Science & Technology Park, Nanshan District, Shenzhen, Guangdong, China 518057 t (86-755) 26012053 f (86-755) 26710594 www.sgs.com.cn  
 中国·广东·深圳市南山区科技园中区M-10栋1号厂房 邮编: 518057 t (86-755) 26012053 f (86-755) 26710594 sgs.china@sgs.com



Polarity: Horizontal; Modulation:802.11ax(Full RU0); Bandwidth:160MHz; Channel:middle

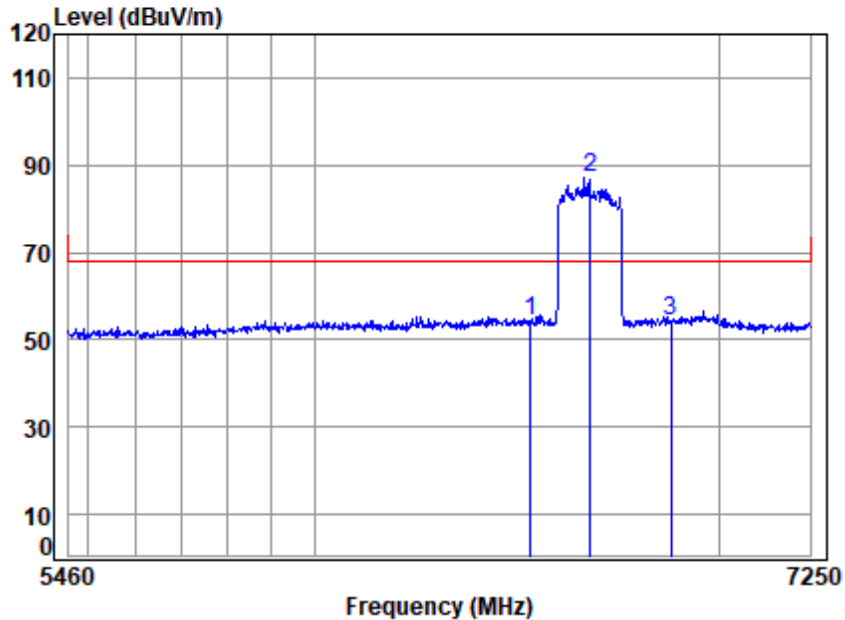

Site : chamber  
 Condition: 3m HORIZONTAL  
 Job No : 00384AT/00385AT  
 Mode : 6665 Band edge  
 : 5G WIFI 11AX160

	Cable	Ant	Preamp	Read	Limit	Over	
Freq	Loss	Factor	Factor	Level	Level	Line	Limit Remark
MHz	dB	dB/m	dB	dBuV	dBuV/m	dBuV/m	dB
1	6515.000	8.57	35.57	35.26	45.33	54.21	68.20 -13.99 peak
2 p	6665.000	8.68	35.20	35.36	78.78	87.30	68.20 19.10 peak
3	6875.000	8.83	35.55	35.49	45.51	54.40	68.20 -13.80 peak



Unless otherwise agreed in writing, this document is issued by the Company subject to its General Conditions of Service printed overleaf, available on request or accessible at <https://www.sgs.com/en/Terms-and-Conditions>. Attention is drawn to the limitation of liability, indemnification and jurisdiction issues defined therein. Any holder of this document is advised that information contained hereon reflects the Company's findings at the time of its intervention only and within the limits of Client's instructions, if any. The Company's sole responsibility is to its Client and this document does not exonerate parties to a transaction from exercising all their rights and obligations under the transaction documents. This document cannot be reproduced except in full, without prior written approval of the Company. Any unauthorized alteration, forgery or falsification of the content or appearance of this document is unlawful and offenders may be prosecuted to the fullest extent of the law. Unless otherwise stated the results shown in this test report refer only to the sample(s) tested and such sample(s) are retained for 30 days only.

Attention: To check the authenticity of testing /inspection report & certificate, please contact us at telephone: (86-755) 8307 1443, or email: CN.Doccheck@sgs.com  
 No.1 Workshop, M-10, Middle Section, Science & Technology Park, Nanshan District, Shenzhen, Guangdong, China 518057 t (86-755) 26012053 f (86-755) 26710594 www.sgs.com.cn  
 中国·广东·深圳市南山区科技园中区M-10栋1号厂房 邮编: 518057 t (86-755) 26012053 f (86-755) 26710594 sgs.china@sgs.com

Polarity: Vertical; Modulation:802.11ax(Full RU0); Bandwidth:160MHz; Channel:middle

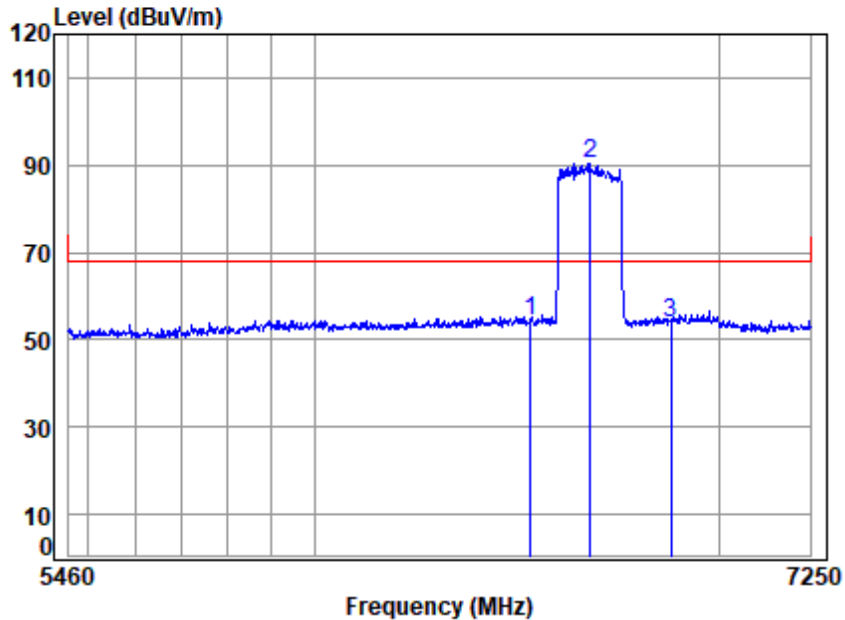

Site : chamber  
 Condition: 3m VERTICAL  
 Job No : 00384AT/00385AT  
 Mode : 6665 Band edge  
 : 5G WIFI 11AX160

		Cable	Ant	Preamp	Read	Limit	Over	
	Freq	Loss	Factor	Factor	Level	Line	Limit	Remark
	MHz	dB	dB/m	dB	dBuV	dBuV/m	dBuV/m	dB
1	6515.000	8.57	35.57	35.26	45.49	54.37	68.20	-13.83 peak
2 p	6665.000	8.68	35.20	35.36	81.93	90.45	68.20	22.25 peak
3	6875.000	8.83	35.55	35.49	44.92	53.81	68.20	-14.39 peak



Unless otherwise agreed in writing, this document is issued by the Company subject to its General Conditions of Service printed overleaf, available on request or accessible at <https://www.sgs.com/en/Terms-and-Conditions>. Attention is drawn to the limitation of liability, indemnification and jurisdiction issues defined therein. Any holder of this document is advised that information contained hereon reflects the Company's findings at the time of its intervention only and within the limits of Client's instructions, if any. The Company's sole responsibility is to its Client and this document does not exonerate parties to a transaction from exercising all their rights and obligations under the transaction documents. This document cannot be reproduced except in full, without prior written approval of the Company. Any unauthorized alteration, forgery or falsification of the content or appearance of this document is unlawful and offenders may be prosecuted to the fullest extent of the law. Unless otherwise stated the results shown in this test report refer only to the sample(s) tested and such sample(s) are retained for 30 days only.

Attention: To check the authenticity of testing /inspection report & certificate, please contact us at telephone: (86-755) 8307 1443, or email: CN.Doccheck@sgs.com  
 No.1 Workshop, M-10, Middle Section, Science & Technology Park, Nanshan District, Shenzhen, Guangdong, China 518057 t (86-755) 26012053 f (86-755) 26710594 www.sgs.com.cn  
 中国·广东·深圳市南山区科技园中区M-10栋1号厂房 邮编: 518057 t (86-755) 26012053 f (86-755) 26710594 sgs.china@sgs.com

Polarity: Horizontal; Modulation:802.11ax(Full RU0); Bandwidth:20MHz; Channel:Low

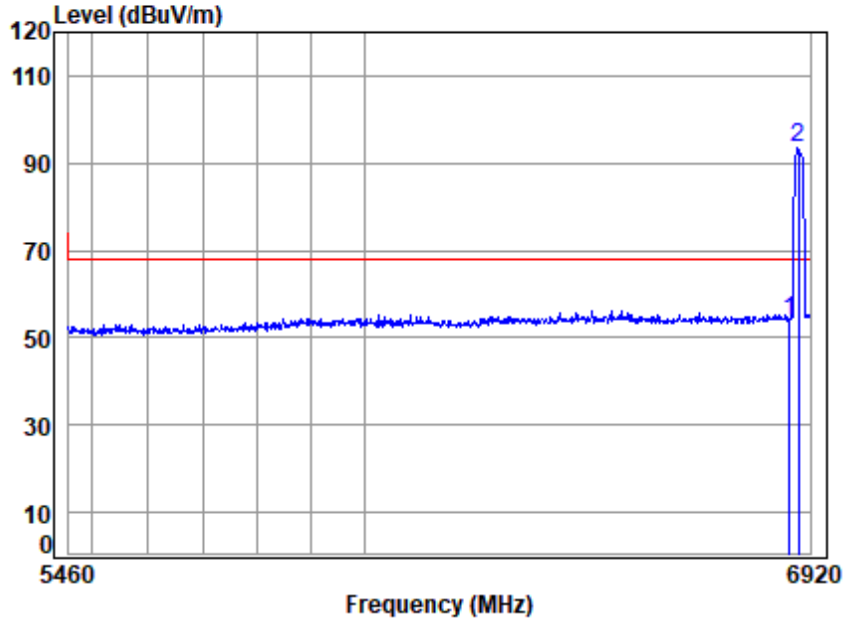

Site : chamber  
 Condition: 3m HORIZONTAL  
 Job No : 00384AT/00385AT  
 Mode : 6895 Band edge  
 : 5G WIFI 11AX20

	Freq	Cable Loss	Ant Factor	Preamp Factor	Read Level	Limit Level	Over Limit	Remark
	MHz	dB	dB/m	dB	dBuV	dBuV/m	dBuV/m	dB
1	6875.000	8.83	35.55	35.49	45.14	54.03	68.20	-14.17 peak
2 p	6895.000	8.85	35.59	35.50	84.54	93.48	68.20	25.28 peak



Unless otherwise agreed in writing, this document is issued by the Company subject to its General Conditions of Service printed overleaf, available on request or accessible at <https://www.sgs.com/en/Terms-and-Conditions>. Attention is drawn to the limitation of liability, indemnification and jurisdiction issues defined therein. Any holder of this document is advised that information contained hereon reflects the Company's findings at the time of its intervention only and within the limits of Client's instructions, if any. The Company's sole responsibility is to its Client and this document does not exonerate parties to a transaction from exercising all their rights and obligations under the transaction documents. This document cannot be reproduced except in full, without prior written approval of the Company. Any unauthorized alteration, forgery or falsification of the content or appearance of this document is unlawful and offenders may be prosecuted to the fullest extent of the law. Unless otherwise stated the results shown in this test report refer only to the sample(s) tested and such sample(s) are retained for 30 days only.

Attention: To check the authenticity of testing /inspection report & certificate, please contact us at telephone: (86-755) 8307 1443, or email: CN.Doccheck@sgs.com  
 No.1 Workshop, M-10, Middle Section, Science & Technology Park, Nanshan District, Shenzhen, Guangdong, China 518057 t (86-755) 26012053 f (86-755) 26710594 www.sgsgroup.com.cn  
 中国·广东·深圳市南山区科技园中区M-10栋1号厂房 邮编: 518057 t (86-755) 26012053 f (86-755) 26710594 sgs.china@sgs.com

Polarity: Vertical; Modulation:802.11ax(Full RU0); Bandwidth:20MHz; Channel:Low

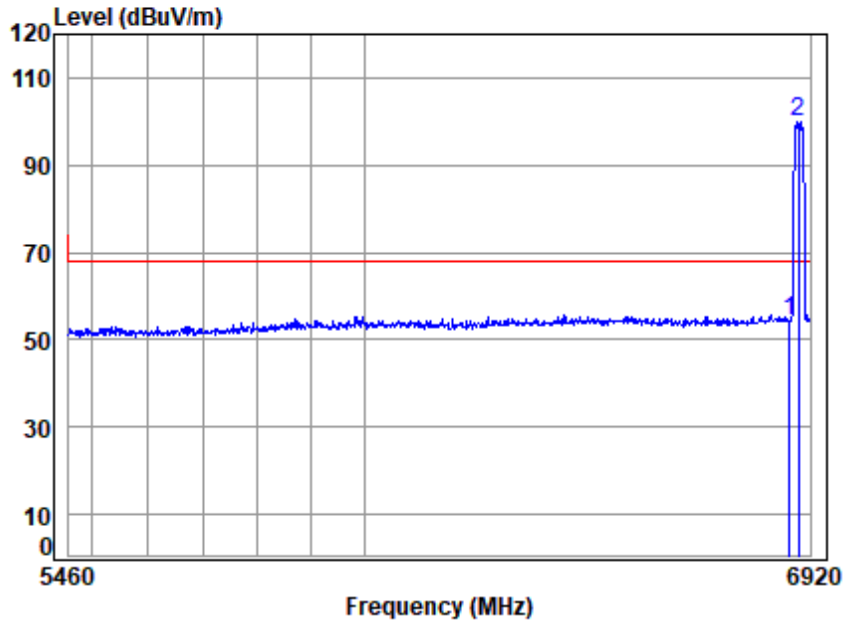

Site : chamber  
 Condition: 3m VERTICAL  
 Job No : 00384AT/00385AT  
 Mode : 6895 Band edge  
 : 5G WIFI 11AX20

	Cable	Ant	Preamp	Read	Limit	Over	
Freq	Loss	Factor	Factor	Level	Level	Line	Limit Remark
MHz	dB	dB/m	dB	dBuV	dBuV/m	dBuV/m	dB
1	6875.000	8.83	35.55	35.49	45.62	54.51	68.20 -13.69 peak
2 p	6895.000	8.85	35.59	35.50	91.18	100.12	68.20 31.92 peak



Unless otherwise agreed in writing, this document is issued by the Company subject to its General Conditions of Service printed overleaf, available on request or accessible at <https://www.sgs.com/en/Terms-and-Conditions>. Attention is drawn to the limitation of liability, indemnification and jurisdiction issues defined therein. Any holder of this document is advised that information contained hereon reflects the Company's findings at the time of its intervention only and within the limits of Client's instructions, if any. The Company's sole responsibility is to its Client and this document does not exonerate parties to a transaction from exercising all their rights and obligations under the transaction documents. This document cannot be reproduced except in full, without prior written approval of the Company. Any unauthorized alteration, forgery or falsification of the content or appearance of this document is unlawful and offenders may be prosecuted to the fullest extent of the law. Unless otherwise stated the results shown in this test report refer only to the sample(s) tested and such sample(s) are retained for 30 days only.

Attention: To check the authenticity of testing /inspection report & certificate, please contact us at telephone: (86-755) 8307 1443, or email: CN.Doccheck@sgs.com  
 No.1 Workshop, M-10, Middle Section, Science & Technology Park, Nanshan District, Shenzhen, Guangdong, China 518057 t (86-755) 26012053 f (86-755) 26710594 www.sgs.com.cn  
 中国·广东·深圳市南山区科技园中区M-10栋1号厂房 邮编: 518057 t (86-755) 26012053 f (86-755) 26710594 sgs.china@sgs.com



Polarity: Horizontal; Modulation:802.11ax(Full RU0); Bandwidth:20MHz; Channel:High

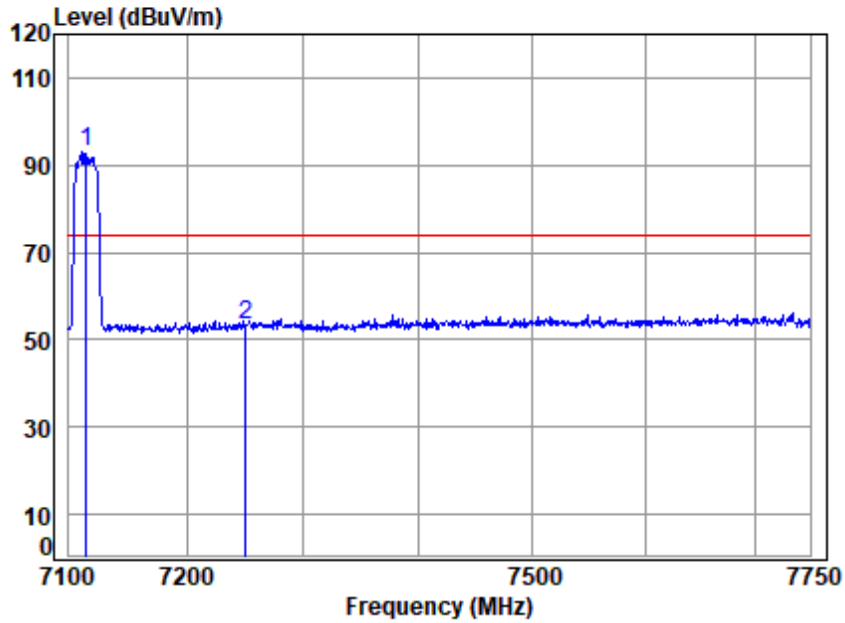

Site : chamber  
 Condition: 3m HORIZONTAL  
 Job No : 00384AT/00385AT  
 Mode : 7115 Band edge  
 : 5G WIFI 11AX20

	Cable	Ant	Preamp	Read	Limit	Over	
Freq	Loss	Factor	Factor	Level	Level	Line	Limit Remark
MHz	dB	dB/m	dB	dBuV	dBuV/m	dBuV/m	dB
1 p 7115.000	9.06	35.80	35.69	84.06	93.23	74.00	19.23 peak
2 7250.000	9.23	35.70	35.83	44.18	53.28	74.00	-20.72 peak



Unless otherwise agreed in writing, this document is issued by the Company subject to its General Conditions of Service printed overleaf, available on request or accessible at <https://www.sgs.com/en/Terms-and-Conditions>. Attention is drawn to the limitation of liability, indemnification and jurisdiction issues defined therein. Any holder of this document is advised that information contained hereon reflects the Company's findings at the time of its intervention only and within the limits of Client's instructions, if any. The Company's sole responsibility is to its Client and this document does not exonerate parties to a transaction from exercising all their rights and obligations under the transaction documents. This document cannot be reproduced except in full, without prior written approval of the Company. Any unauthorized alteration, forgery or falsification of the content or appearance of this document is unlawful and offenders may be prosecuted to the fullest extent of the law. Unless otherwise stated the results shown in this test report refer only to the sample(s) tested and such sample(s) are retained for 30 days only.

Polarity: Horizontal; Modulation:802.11ax(Full RU0); Bandwidth:20MHz; Channel:High

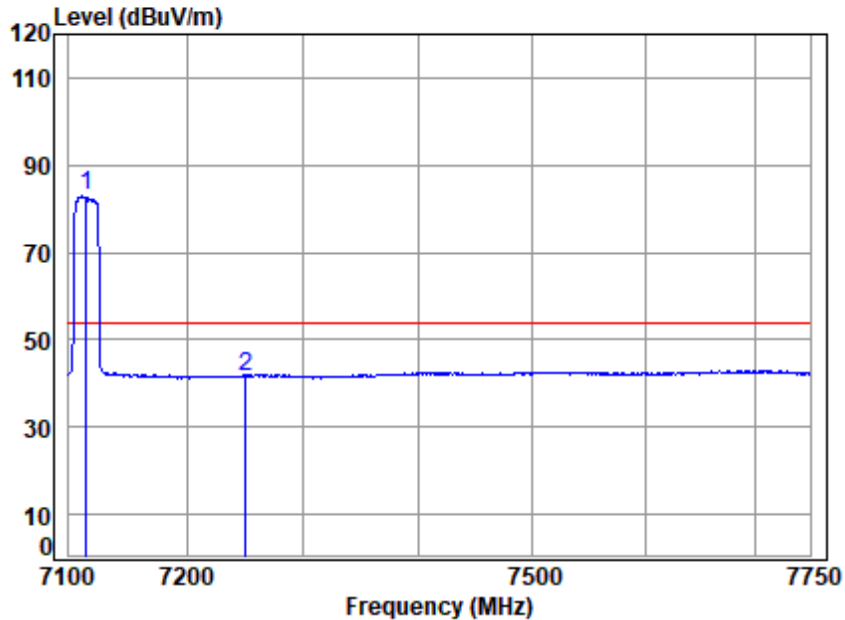

Site : chamber  
 Condition: 3m HORIZONTAL  
 Job No : 00384AT/00385AT  
 Mode : 7115 Band edge  
 : 5G WIFI 11AX20

	Cable	Ant	Preamp	Read	Limit	Over		
Freq	Loss	Factor	Factor	Level	Level	Line	Limit	Remark
MHz	dB	dB/m	dB	dBuV	dBuV/m	dBuV/m	dB	
1 q 7115.000	9.06	35.80	35.69	73.68	82.85	54.00	28.85	Average
2 7250.000	9.23	35.70	35.83	32.63	41.73	54.00	-12.27	Average



Unless otherwise agreed in writing, this document is issued by the Company subject to its General Conditions of Service printed overleaf, available on request or accessible at <https://www.sgs.com/en/Terms-and-Conditions>. Attention is drawn to the limitation of liability, indemnification and jurisdiction issues defined therein. Any holder of this document is advised that information contained hereon reflects the Company's findings at the time of its intervention only and within the limits of Client's instructions, if any. The Company's sole responsibility is to its Client and this document does not exonerate parties to a transaction from exercising all their rights and obligations under the transaction documents. This document cannot be reproduced except in full, without prior written approval of the Company. Any unauthorized alteration, forgery or falsification of the content or appearance of this document is unlawful and offenders may be prosecuted to the fullest extent of the law. Unless otherwise stated the results shown in this test report refer only to the sample(s) tested and such sample(s) are retained for 30 days only.  
 Attention: To check the authenticity of testing /inspection report & certificate, please contact us at telephone: (86-755) 8307 1443, or email: CN.Doccheck@sgs.com  
 No.1 Workshop, M-10, Middle Section, Science & Technology Park, Nanshan District, Shenzhen, Guangdong, China 518057 t (86-755) 26012053 f (86-755) 26710594 www.sgsgroup.com.cn  
 中国·广东·深圳市南山区科技园中区M-10栋1号厂房 邮编: 518057 t (86-755) 26012053 f (86-755) 26710594 sgs.china@sgs.com

Polarity: Vertical; Modulation:802.11ax(Full RU0); Bandwidth:20MHz; Channel:High

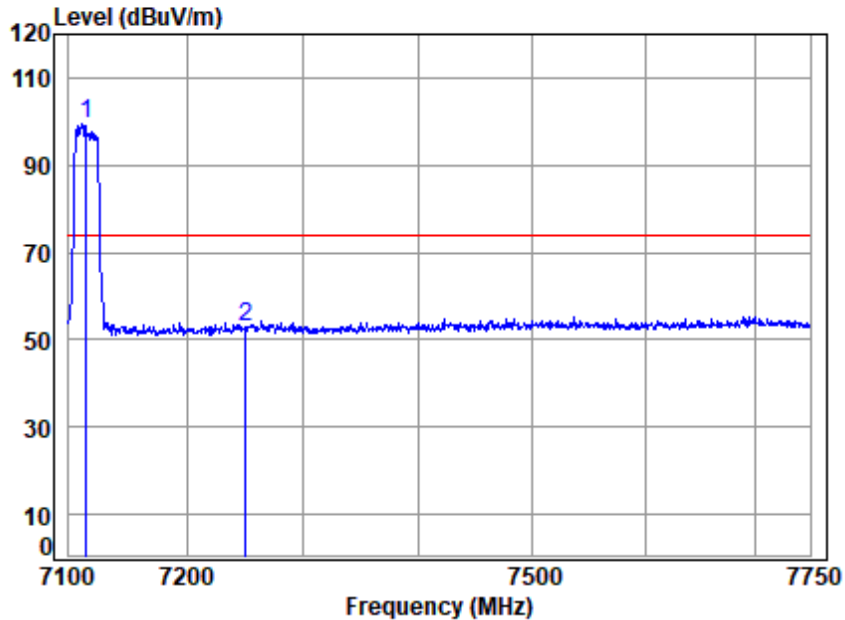

Site : chamber  
 Condition: 3m VERTICAL  
 Job No : 00384AT/00385AT  
 Mode : 7115 Band edge  
 : 5G WIFI 11AX20

	Cable	Ant	Preamp	Read	Limit	Over	
Freq	Loss	Factor	Factor	Level	Level	Line	Limit Remark
MHz	dB	dB/m	dB	dBuV	dBuV/m	dBuV/m	dB
1 p 7115.000	9.06	35.80	35.69	90.12	99.29	74.00	25.29 Peak
2 7250.000	9.23	35.70	35.83	43.91	53.01	74.00	-20.99 Peak



Unless otherwise agreed in writing, this document is issued by the Company subject to its General Conditions of Service printed overleaf, available on request or accessible at <https://www.sgs.com/en/Terms-and-Conditions>. Attention is drawn to the limitation of liability, indemnification and jurisdiction issues defined therein. Any holder of this document is advised that information contained hereon reflects the Company's findings at the time of its intervention only and within the limits of Client's instructions, if any. The Company's sole responsibility is to its Client and this document does not exonerate parties to a transaction from exercising all their rights and obligations under the transaction documents. This document cannot be reproduced except in full, without prior written approval of the Company. Any unauthorized alteration, forgery or falsification of the content or appearance of this document is unlawful and offenders may be prosecuted to the fullest extent of the law. Unless otherwise stated the results shown in this test report refer only to the sample(s) tested and such sample(s) are retained for 30 days only.

Attention: To check the authenticity of testing /inspection report & certificate, please contact us at telephone: (86-755) 8307 1443, or email: CN.Doccheck@sgs.com

No.1 Workshop, M-10, Middle Section, Science & Technology Park, Nanshan District, Shenzhen, Guangdong, China 518057 t (86-755) 26012053 f (86-755) 26710594 www.sgs.com.cn  
 中国·广东·深圳市南山区科技园中区M-10栋1号厂房 邮编: 518057 t (86-755) 26012053 f (86-755) 26710594 sgs.china@sgs.com

Polarity: Vertical; Modulation:802.11ax(Full RU0); Bandwidth:20MHz; Channel:High

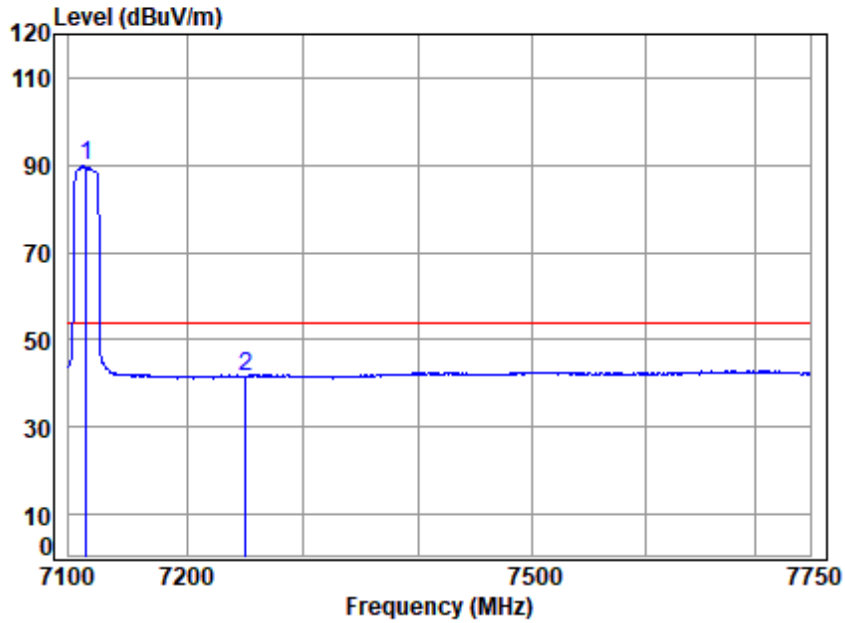

Site : chamber  
 Condition: 3m VERTICAL  
 Job No : 00384AT/00385AT  
 Mode : 7115 Band edge  
 : 5G WIFI 11AX20

	Cable	Ant	Preamp	Read	Limit	Over		
Freq	Loss	Factor	Factor	Level	Level	Line	Limit	Remark
MHz	dB	dB/m	dB	dBuV	dBuV/m	dBuV/m	dB	
1 q 7115.000	9.06	35.80	35.69	80.68	89.85	54.00	35.85	Average
2 7250.000	9.23	35.70	35.83	32.59	41.69	54.00	-12.31	Average



Unless otherwise agreed in writing, this document is issued by the Company subject to its General Conditions of Service printed overleaf, available on request or accessible at <https://www.sgs.com/en/Terms-and-Conditions>. Attention is drawn to the limitation of liability, indemnification and jurisdiction issues defined therein. Any holder of this document is advised that information contained hereon reflects the Company's findings at the time of its intervention only and within the limits of Client's instructions, if any. The Company's sole responsibility is to its Client and this document does not exonerate parties to a transaction from exercising all their rights and obligations under the transaction documents. This document cannot be reproduced except in full, without prior written approval of the Company. Any unauthorized alteration, forgery or falsification of the content or appearance of this document is unlawful and offenders may be prosecuted to the fullest extent of the law. Unless otherwise stated the results shown in this test report refer only to the sample(s) tested and such sample(s) are retained for 30 days only.  
 Attention: To check the authenticity of testing /inspection report & certificate, please contact us at telephone: (86-755) 8307 1443, or email: CN.Doccheck@sgs.com  
 No.1 Workshop, M-10, Middle Section, Science & Technology Park, Nanshan District, Shenzhen, Guangdong, China 518057 t (86-755) 26012053 f (86-755) 26710594 www.sgsgroup.com.cn  
 中国·广东·深圳市南山区科技园中区M-10栋1号厂房 邮编: 518057 t (86-755) 26012053 f (86-755) 26710594 sgs.china@sgs.com



Polarity: Horizontal; Modulation:802.11ax(Full RU0); Bandwidth:40MHz; Channel:Low

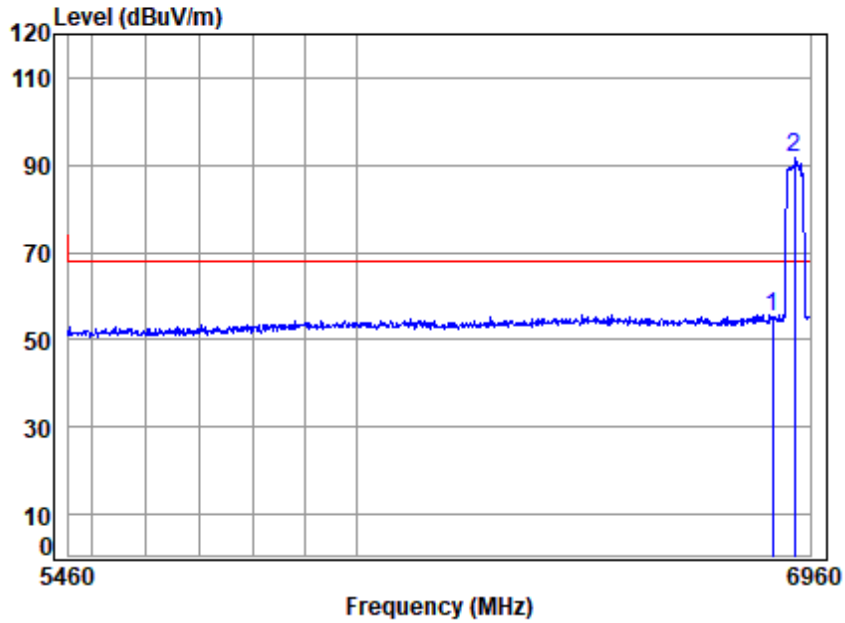

Site : chamber  
 Condition: 3m HORIZONTAL  
 Job No : 00384AT/00385AT  
 Mode : 6925 Band edge  
 : 5G WIFI 11AX40

	Cable	Ant	Preamp	Read	Limit	Over	
Freq	Loss	Factor	Factor	Level	Level	Line	Limit Remark
MHz	dB	dB/m	dB	dBuV	dBuV/m	dBuV/m	dB
1	6875.000	8.83	35.55	35.49	46.13	55.02	68.20 -13.18 peak
2	p 6925.000	8.87	35.70	35.52	82.66	91.71	68.20 23.51 peak



Unless otherwise agreed in writing, this document is issued by the Company subject to its General Conditions of Service printed overleaf, available on request or accessible at <https://www.sgs.com/en/Terms-and-Conditions>. Attention is drawn to the limitation of liability, indemnification and jurisdiction issues defined therein. Any holder of this document is advised that information contained hereon reflects the Company's findings at the time of its intervention only and within the limits of Client's instructions, if any. The Company's sole responsibility is to its Client and this document does not exonerate parties to a transaction from exercising all their rights and obligations under the transaction documents. This document cannot be reproduced except in full, without prior written approval of the Company. Any unauthorized alteration, forgery or falsification of the content or appearance of this document is unlawful and offenders may be prosecuted to the fullest extent of the law. Unless otherwise stated the results shown in this test report refer only to the sample(s) tested and such sample(s) are retained for 30 days only.

Attention: To check the authenticity of testing /inspection report & certificate, please contact us at telephone: (86-755) 8307 1443, or email: CN.Doccheck@sgs.com  
 No.1 Workshop, M-10, Middle Section, Science & Technology Park, Nanshan District, Shenzhen, Guangdong, China 518057 t (86-755) 26012053 f (86-755) 26710594 www.sgs.com.cn  
 中国·广东·深圳市南山区科技园中区M-10栋1号厂房 邮编: 518057 t (86-755) 26012053 f (86-755) 26710594 sgs.china@sgs.com

Polarity: Vertical; Modulation:802.11ax(Full RU0); Bandwidth:40MHz; Channel:Low

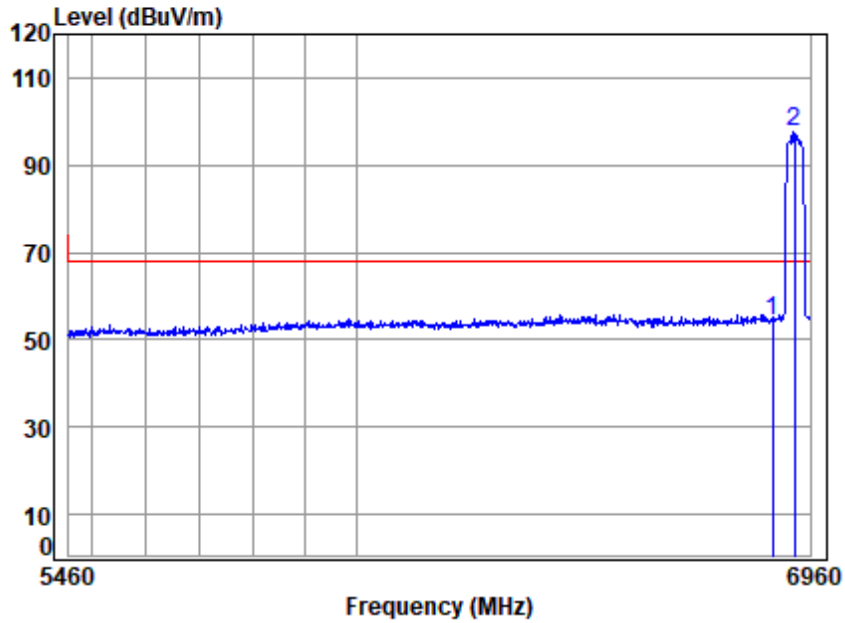

Site : chamber  
 Condition: 3m VERTICAL  
 Job No : 00384AT/00385AT  
 Mode : 6925 Band edge  
 : 5G WIFI 11AX40

	Cable	Ant	Preamp	Read	Limit	Over	
Freq	Loss	Factor	Factor	Level	Level	Line	Limit Remark
MHz	dB	dB/m	dB	dBuV	dBuV/m	dBuV/m	dB
1 6875.000	8.83	35.55	35.49	45.60	54.49	68.20	-13.71 peak
2 p 6925.000	8.87	35.70	35.52	88.81	97.86	68.20	29.66 peak



Unless otherwise agreed in writing, this document is issued by the Company subject to its General Conditions of Service printed overleaf, available on request or accessible at <https://www.sgs.com/en/Terms-and-Conditions>. Attention is drawn to the limitation of liability, indemnification and jurisdiction issues defined therein. Any holder of this document is advised that information contained hereon reflects the Company's findings at the time of its intervention only and within the limits of Client's instructions, if any. The Company's sole responsibility is to its Client and this document does not exonerate parties to a transaction from exercising all their rights and obligations under the transaction documents. This document cannot be reproduced except in full, without prior written approval of the Company. Any unauthorized alteration, forgery or falsification of the content or appearance of this document is unlawful and offenders may be prosecuted to the fullest extent of the law. Unless otherwise stated the results shown in this test report refer only to the sample(s) tested and such sample(s) are retained for 30 days only.

Attention: To check the authenticity of testing /inspection report & certificate, please contact us at telephone: (86-755) 8307 1443, or email: CN.Doccheck@sgs.com  
 No.1 Workshop, M-10, Middle Section, Science & Technology Park, Nanshan District, Shenzhen, Guangdong, China 518057 t (86-755) 26012053 f (86-755) 26710594 www.sgsgroup.com.cn  
 中国·广东·深圳市南山区科技园中区M-10栋1号厂房 邮编: 518057 t (86-755) 26012053 f (86-755) 26710594 sgs.china@sgs.com

Polarity: Horizontal; Modulation:802.11ax(Full RU0); Bandwidth:40MHz; Channel:High

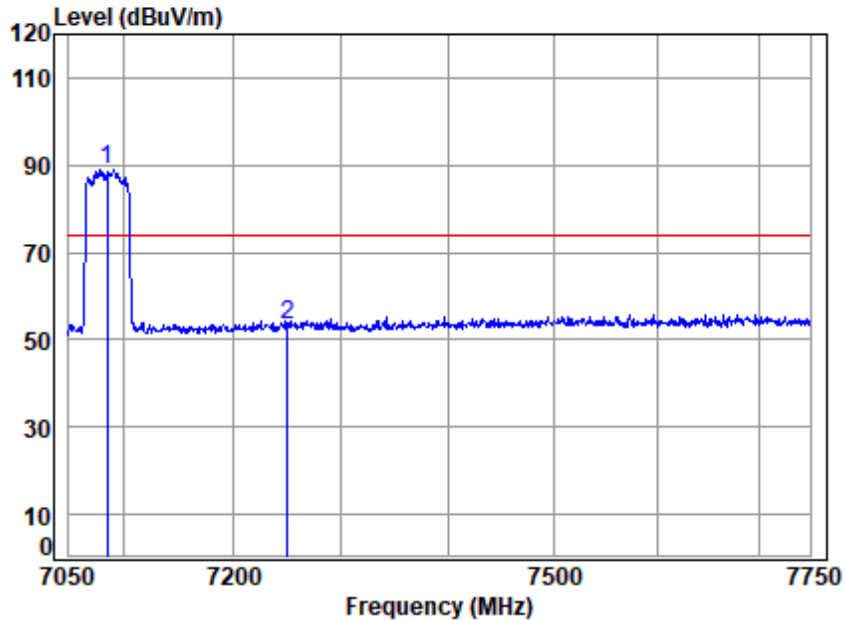

Site : chamber  
 Condition: 3m HORIZONTAL  
 Job No : 00384AT/00385AT  
 Mode : 7085 Band edge  
 : 5G WIFI 11AX40

	Cable	Ant	Preamp	Read	Limit	Over	
Freq	Loss	Factor	Factor	Level	Level	Line	Limit Remark
MHz	dB	dB/m	dB	dBuV	dBuV/m	dBuV/m	dB
1 p 7085.000	9.03	35.77	35.66	79.85	88.99	74.00	14.99 peak
2 7250.000	9.23	35.70	35.83	44.18	53.28	74.00	-20.72 peak



Unless otherwise agreed in writing, this document is issued by the Company subject to its General Conditions of Service printed overleaf, available on request or accessible at <https://www.sgs.com/en/Terms-and-Conditions>. Attention is drawn to the limitation of liability, indemnification and jurisdiction issues defined therein. Any holder of this document is advised that information contained hereon reflects the Company's findings at the time of its intervention only and within the limits of Client's instructions, if any. The Company's sole responsibility is to its Client and this document does not exonerate parties to a transaction from exercising all their rights and obligations under the transaction documents. This document cannot be reproduced except in full, without prior written approval of the Company. Any unauthorized alteration, forgery or falsification of the content or appearance of this document is unlawful and offenders may be prosecuted to the fullest extent of the law. Unless otherwise stated the results shown in this test report refer only to the sample(s) tested and such sample(s) are retained for 30 days only.

Attention: To check the authenticity of testing /inspection report & certificate, please contact us at telephone: (86-755) 8307 1443, or email: CN.Doccheck@sgs.com  
 No.1 Workshop, M-10, Middle Section, Science & Technology Park, Nanshan District, Shenzhen, Guangdong, China 518057 t (86-755) 26012053 f (86-755) 26710594 www.sgsgroup.com.cn  
 中国·广东·深圳市南山区科技园中区M-10栋1号厂房 邮编: 518057 t (86-755) 26012053 f (86-755) 26710594 sgs.china@sgs.com

Polarity: Horizontal; Modulation:802.11ax(Full RU0); Bandwidth:40MHz; Channel:High

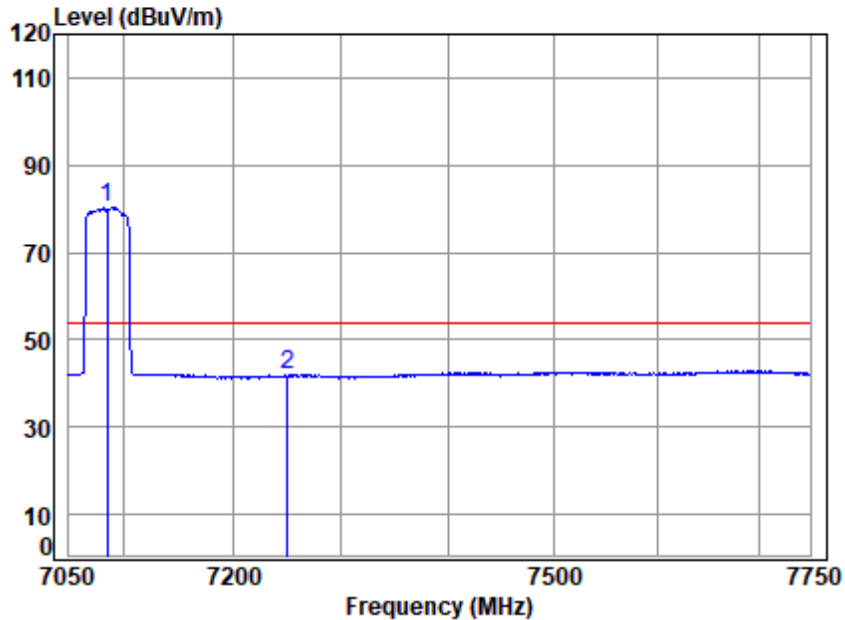

Site : chamber  
 Condition: 3m HORIZONTAL  
 Job No : 00384AT/00385AT  
 Mode : 7085 Band edge  
 : 5G WIFI 11AX40

	Cable	Ant	Preamp	Read	Limit	Over		
Freq	Loss	Factor	Factor	Level	Level	Line	Limit	Remark
MHz	dB	dB/m	dB	dBuV	dBuV/m	dBuV/m	dB	
1 q 7085.000	9.03	35.77	35.66	71.13	80.27	54.00	26.27	Average
2 7250.000	9.23	35.70	35.83	32.65	41.75	54.00	-12.25	Average



Unless otherwise agreed in writing, this document is issued by the Company subject to its General Conditions of Service printed overleaf, available on request or accessible at <https://www.sgs.com/en/Terms-and-Conditions>. Attention is drawn to the limitation of liability, indemnification and jurisdiction issues defined therein. Any holder of this document is advised that information contained hereon reflects the Company's findings at the time of its intervention only and within the limits of Client's instructions, if any. The Company's sole responsibility is to its Client and this document does not exonerate parties to a transaction from exercising all their rights and obligations under the transaction documents. This document cannot be reproduced except in full, without prior written approval of the Company. Any unauthorized alteration, forgery or falsification of the content or appearance of this document is unlawful and offenders may be prosecuted to the fullest extent of the law. Unless otherwise stated the results shown in this test report refer only to the sample(s) tested and such sample(s) are retained for 30 days only.

Attention: To check the authenticity of testing /inspection report & certificate, please contact us at telephone: (86-755) 8307 1443, or email: CN.Doccheck@sgs.com  
 No.1 Workshop, M-10, Middle Section, Science & Technology Park, Nanshan District, Shenzhen, Guangdong, China 518057 t (86-755) 26012053 f (86-755) 26710594 www.sgs.com.cn  
 中国·广东·深圳市南山区科技园中区M-10栋1号厂房 邮编: 518057 t (86-755) 26012053 f (86-755) 26710594 sgs.china@sgs.com



Polarity: Vertical; Modulation:802.11ax(Full RU0); Bandwidth:40MHz; Channel:High

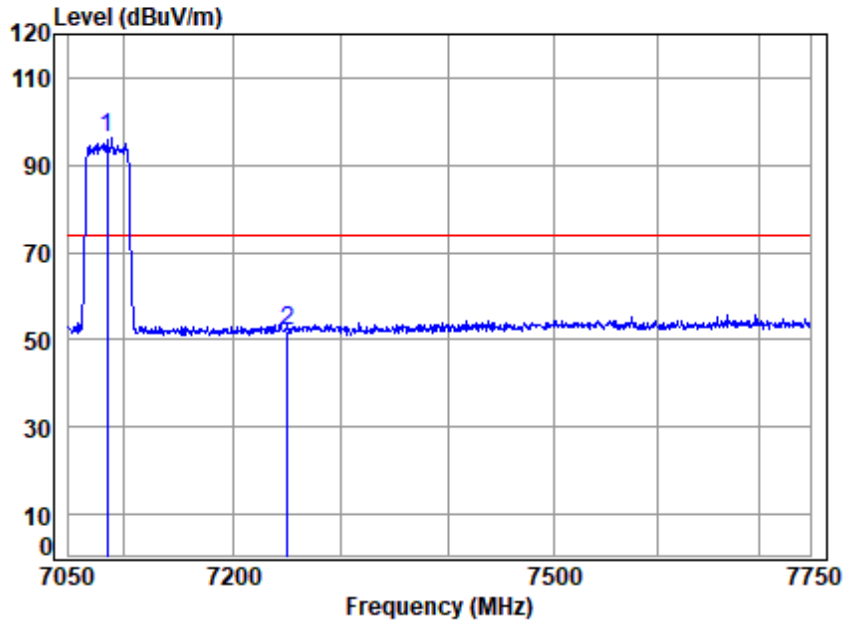

Site : chamber  
 Condition: 3m VERTICAL  
 Job No : 00384AT/00385AT  
 Mode : 7085 Band edge  
 : 5G WIFI 11AX40

	Cable	Ant	Preamp	Read	Limit	Over	
Freq	Loss	Factor	Factor	Level	Level	Line	Limit Remark
MHz	dB	dB/m	dB	dBuV	dBuV/m	dBuV/m	dB
1 p 7085.000	9.03	35.77	35.66	87.20	96.34	74.00	22.34 Peak
2 7250.000	9.23	35.70	35.83	42.81	51.91	74.00	-22.09 Peak



Unless otherwise agreed in writing, this document is issued by the Company subject to its General Conditions of Service printed overleaf, available on request or accessible at <https://www.sgs.com/en/Terms-and-Conditions>. Attention is drawn to the limitation of liability, indemnification and jurisdiction issues defined therein. Any holder of this document is advised that information contained hereon reflects the Company's findings at the time of its intervention only and within the limits of Client's instructions, if any. The Company's sole responsibility is to its Client and this document does not exonerate parties to a transaction from exercising all their rights and obligations under the transaction documents. This document cannot be reproduced except in full, without prior written approval of the Company. Any unauthorized alteration, forgery or falsification of the content or appearance of this document is unlawful and offenders may be prosecuted to the fullest extent of the law. Unless otherwise stated the results shown in this test report refer only to the sample(s) tested and such sample(s) are retained for 30 days only.

Attention: To check the authenticity of testing /inspection report & certificate, please contact us at telephone: (86-755) 8307 1443, or email: CN.Doccheck@sgs.com  
 No.1 Workshop, M-10, Middle Section, Science & Technology Park, Nanshan District, Shenzhen, Guangdong, China 518057 t (86-755) 26012053 f (86-755) 26710594 www.sgs.com.cn  
 中国·广东·深圳市南山区科技园中区M-10栋1号厂房 邮编: 518057 t (86-755) 26012053 f (86-755) 26710594 sgs.china@sgs.com

Polarity: Vertical; Modulation:802.11ax(Full RU0); Bandwidth:40MHz; Channel:High

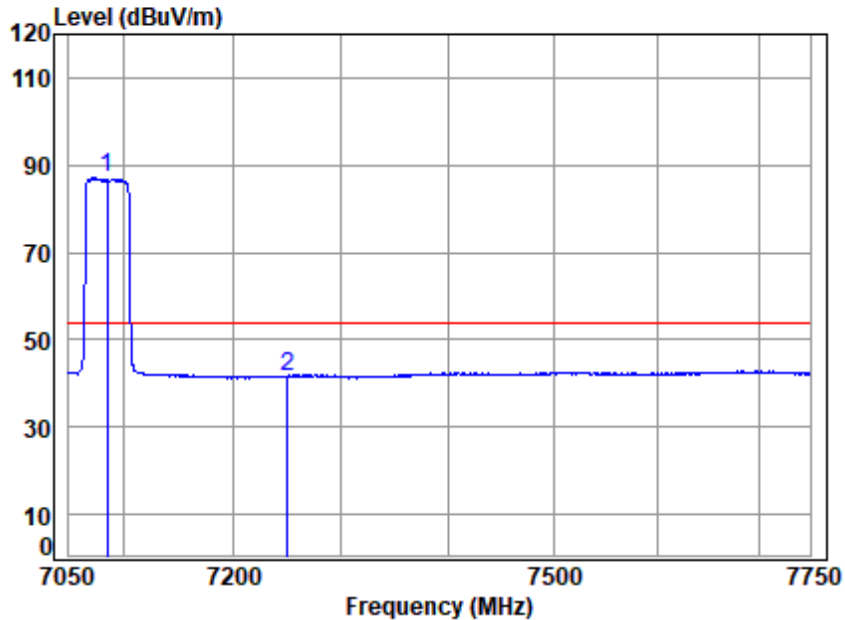

Site : chamber  
 Condition: 3m VERTICAL  
 Job No : 00384AT/00385AT  
 Mode : 7085 Band edge  
 : 5G WIFI 11AX40

	Cable	Ant	Preamp	Read	Limit	Over		
Freq	Loss	Factor	Factor	Level	Level	Line	Limit	Remark
MHz	dB	dB/m	dB	dBuV	dBuV/m	dBuV/m	dB	
1 q 7085.000	9.03	35.77	35.66	77.87	87.01	54.00	33.01	Average
2 7250.000	9.23	35.70	35.83	32.57	41.67	54.00	-12.33	Average



Unless otherwise agreed in writing, this document is issued by the Company subject to its General Conditions of Service printed overleaf, available on request or accessible at <https://www.sgs.com/en/Terms-and-Conditions>. Attention is drawn to the limitation of liability, indemnification and jurisdiction issues defined therein. Any holder of this document is advised that information contained hereon reflects the Company's findings at the time of its intervention only and within the limits of Client's instructions, if any. The Company's sole responsibility is to its Client and this document does not exonerate parties to a transaction from exercising all their rights and obligations under the transaction documents. This document cannot be reproduced except in full, without prior written approval of the Company. Any unauthorized alteration, forgery or falsification of the content or appearance of this document is unlawful and offenders may be prosecuted to the fullest extent of the law. Unless otherwise stated the results shown in this test report refer only to the sample(s) tested and such sample(s) are retained for 30 days only.

Attention: To check the authenticity of testing /inspection report & certificate, please contact us at telephone: (86-755) 8307 1443, or email: CN.Doccheck@sgs.com  
 No.1 Workshop, M-10, Middle Section, Science & Technology Park, Nanshan District, Shenzhen, Guangdong, China 518057 t (86-755) 26012053 f (86-755) 26710594 www.sgs.com.cn  
 中国·广东·深圳市南山区科技园中区M-10栋1号厂房 邮编: 518057 t (86-755) 26012053 f (86-755) 26710594 sgs.china@sgs.com

Polarity: Horizontal; Modulation:802.11ax(Full RU0); Bandwidth:80MHz; Channel:Low

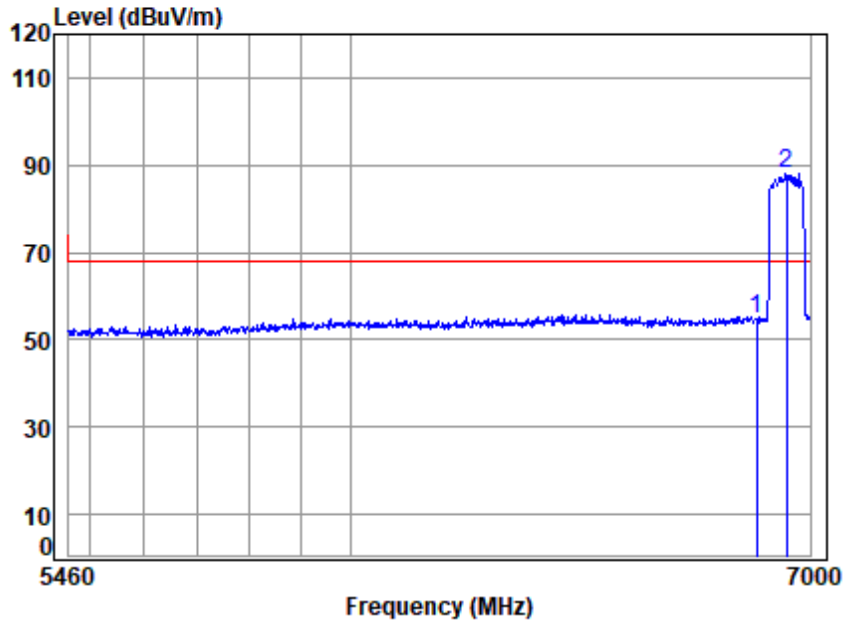

Site : chamber  
 Condition: 3m HORIZONTAL  
 Job No : 00384AT/00385AT  
 Mode : 6945 Band edge  
 : 5G WIFI 11AX80

	Cable	Ant	Preamp	Read	Limit	Over	
Freq	Loss	Factor	Factor	Level	Level	Line	Limit Remark
MHz	dB	dB/m	dB	dBuV	dBuV/m	dBuV/m	dB
1	6875.000	8.83	35.55	35.49	45.89	54.78	68.20 -13.42 peak
2	p 6945.000	8.88	35.78	35.54	78.87	87.99	68.20 19.79 peak



Unless otherwise agreed in writing, this document is issued by the Company subject to its General Conditions of Service printed overleaf, available on request or accessible at <https://www.sgs.com/en/Terms-and-Conditions>. Attention is drawn to the limitation of liability, indemnification and jurisdiction issues defined therein. Any holder of this document is advised that information contained hereon reflects the Company's findings at the time of its intervention only and within the limits of Client's instructions, if any. The Company's sole responsibility is to its Client and this document does not exonerate parties to a transaction from exercising all their rights and obligations under the transaction documents. This document cannot be reproduced except in full, without prior written approval of the Company. Any unauthorized alteration, forgery or falsification of the content or appearance of this document is unlawful and offenders may be prosecuted to the fullest extent of the law. Unless otherwise stated the results shown in this test report refer only to the sample(s) tested and such sample(s) are retained for 30 days only.

Attention: To check the authenticity of testing /inspection report & certificate, please contact us at telephone: (86-755) 8307 1443, or email: CN.Doccheck@sgs.com  
 No.1 Workshop, M-10, Middle Section, Science & Technology Park, Nanshan District, Shenzhen, Guangdong, China 518057 t (86-755) 26012053 f (86-755) 26710594 www.sgs.com.cn  
 中国·广东·深圳市南山区科技园中区M-10栋1号厂房 邮编: 518057 t (86-755) 26012053 f (86-755) 26710594 sgs.china@sgs.com

Polarity: Vertical; Modulation:802.11ax(Full RU0); Bandwidth:80MHz; Channel:Low

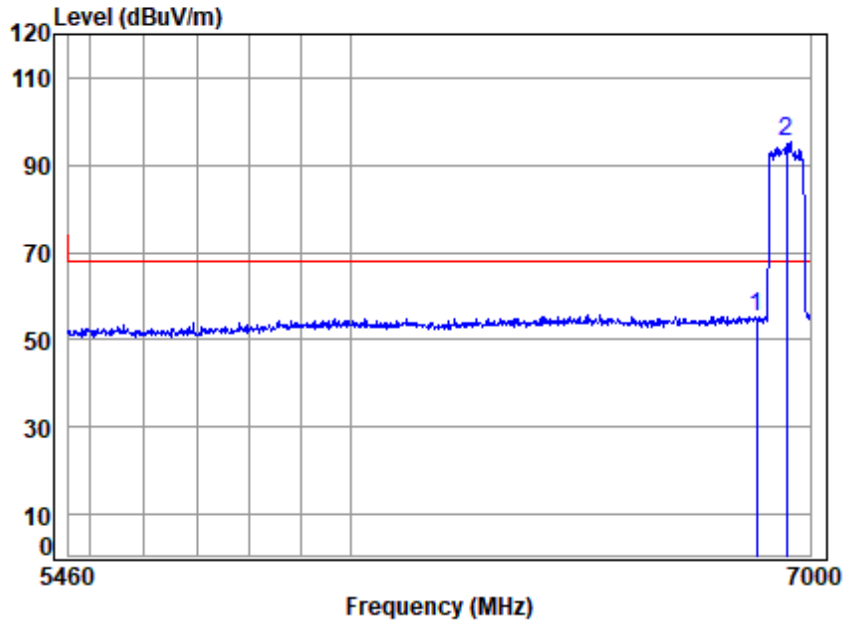

Site : chamber  
 Condition: 3m VERTICAL  
 Job No : 00384AT/00385AT  
 Mode : 6945 Band edge  
 : 5G WIFI 11AX80

	Cable	Ant	Preamp	Read	Limit	Over	
Freq	Loss	Factor	Factor	Level	Level	Line	Limit Remark
MHz	dB	dB/m	dB	dBuV	dBuV/m	dBuV/m	dB
1	6875.000	8.83	35.55	35.49	46.42	55.31	68.20 -12.89 peak
2	p 6945.000	8.88	35.78	35.54	86.33	95.45	68.20 27.25 peak



Unless otherwise agreed in writing, this document is issued by the Company subject to its General Conditions of Service printed overleaf, available on request or accessible at <https://www.sgs.com/en/Terms-and-Conditions>. Attention is drawn to the limitation of liability, indemnification and jurisdiction issues defined therein. Any holder of this document is advised that information contained hereon reflects the Company's findings at the time of its intervention only and within the limits of Client's instructions, if any. The Company's sole responsibility is to its Client and this document does not exonerate parties to a transaction from exercising all their rights and obligations under the transaction documents. This document cannot be reproduced except in full, without prior written approval of the Company. Any unauthorized alteration, forgery or falsification of the content or appearance of this document is unlawful and offenders may be prosecuted to the fullest extent of the law. Unless otherwise stated the results shown in this test report refer only to the sample(s) tested and such sample(s) are retained for 30 days only.

Attention: To check the authenticity of testing /inspection report & certificate, please contact us at telephone: (86-755) 8307 1443, or email: CN.Doccheck@sgs.com  
 No.1 Workshop, M-10, Middle Section, Science & Technology Park, Nanshan District, Shenzhen, Guangdong, China 518057 t (86-755) 26012053 f (86-755) 26710594 www.sgsgroup.com.cn  
 中国·广东·深圳市南山区科技园中区M-10栋1号厂房 邮编: 518057 t (86-755) 26012053 f (86-755) 26710594 sgs.china@sgs.com



Polarity: Horizontal; Modulation:802.11ax(Full RU0); Bandwidth:80MHz; Channel:High

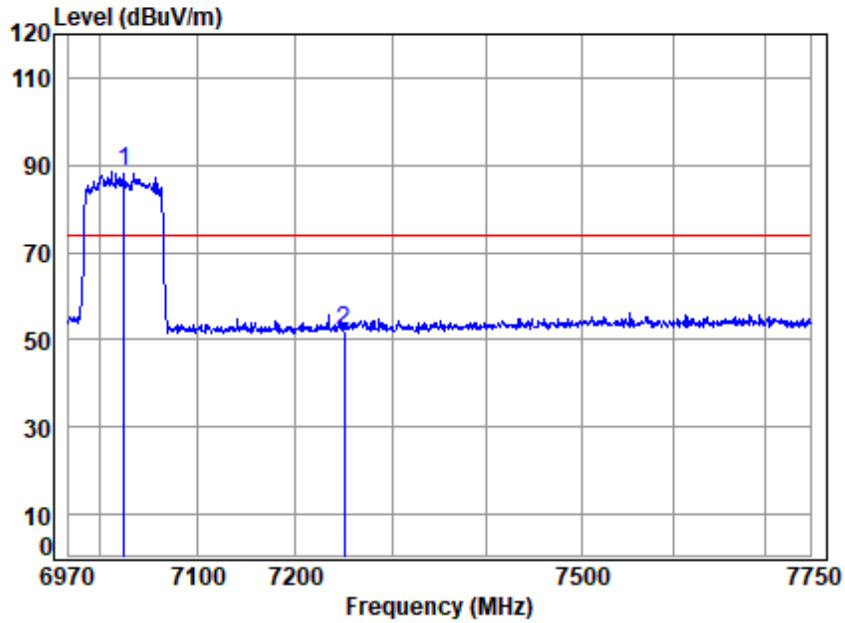

Site : chamber  
 Condition: 3m HORIZONTAL  
 Job No : 00384AT/00385AT  
 Mode : 7025 Band edge  
 : 5G WIFI 11AX80

	Cable	Ant	Preamp	Read	Limit	Over	
Freq	Loss	Factor	Factor	Level	Level	Line	Limit Remark
MHz	dB	dB/m	dB	dBuV	dBuV/m	dBuV/m	dB
1 p 7025.000	8.95	35.70	35.60	79.52	88.57	74.00	14.57 peak
2 7250.000	9.23	35.70	35.83	42.95	52.05	74.00	-21.95 peak



Unless otherwise agreed in writing, this document is issued by the Company subject to its General Conditions of Service printed overleaf, available on request or accessible at <https://www.sgs.com/en/Terms-and-Conditions>. Attention is drawn to the limitation of liability, indemnification and jurisdiction issues defined therein. Any holder of this document is advised that information contained hereon reflects the Company's findings at the time of its intervention only and within the limits of Client's instructions, if any. The Company's sole responsibility is to its Client and this document does not exonerate parties to a transaction from exercising all their rights and obligations under the transaction documents. This document cannot be reproduced except in full, without prior written approval of the Company. Any unauthorized alteration, forgery or falsification of the content or appearance of this document is unlawful and offenders may be prosecuted to the fullest extent of the law. Unless otherwise stated the results shown in this test report refer only to the sample(s) tested and such sample(s) are retained for 30 days only.

Attention: To check the authenticity of testing /inspection report & certificate, please contact us at telephone: (86-755) 8307 1443, or email: CN.Doccheck@sgs.com

No.1 Workshop, M-10, Middle Section, Science & Technology Park, Nanshan District, Shenzhen, Guangdong, China 518057 t (86-755) 26012053 f (86-755) 26710594 www.sgs.com.cn  
 中国·广东·深圳市南山区科技园中区M-10栋1号厂房 邮编: 518057 t (86-755) 26012053 f (86-755) 26710594 sgs.china@sgs.com

Polarity: Horizontal; Modulation:802.11ax(Full RU0); Bandwidth:80MHz; Channel:High

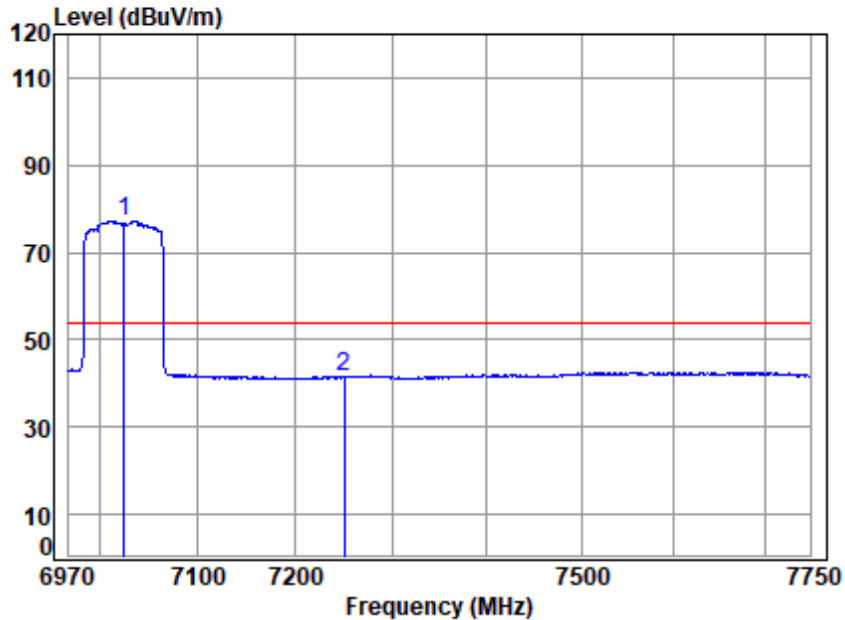

Site : chamber  
 Condition: 3m HORIZONTAL  
 Job No : 00384AT/00385AT  
 Mode : 7025 Band edge  
 : 5G WIFI 11AX80

	Cable	Ant	Preamp	Read	Limit	Over		
Freq	Loss	Factor	Factor	Level	Level	Line	Limit	Remark
MHz	dB	dB/m	dB	dBuV	dBuV/m	dBuV/m	dB	
1 q 7025.000	8.95	35.70	35.60	68.21	77.26	54.00	23.26	Average
2 7250.000	9.23	35.70	35.83	32.41	41.51	54.00	-12.49	Average



Unless otherwise agreed in writing, this document is issued by the Company subject to its General Conditions of Service printed overleaf, available on request or accessible at <https://www.sgs.com/en/Terms-and-Conditions>. Attention is drawn to the limitation of liability, indemnification and jurisdiction issues defined therein. Any holder of this document is advised that information contained hereon reflects the Company's findings at the time of its intervention only and within the limits of Client's instructions, if any. The Company's sole responsibility is to its Client and this document does not exonerate parties to a transaction from exercising all their rights and obligations under the transaction documents. This document cannot be reproduced except in full, without prior written approval of the Company. Any unauthorized alteration, forgery or falsification of the content or appearance of this document is unlawful and offenders may be prosecuted to the fullest extent of the law. Unless otherwise stated the results shown in this test report refer only to the sample(s) tested and such sample(s) are retained for 30 days only.

Attention: To check the authenticity of testing /inspection report & certificate, please contact us at telephone: (86-755) 8307 1443, or email: CN.Doccheck@sgs.com  
 No.1 Workshop, M-10, Middle Section, Science & Technology Park, Nanshan District, Shenzhen, Guangdong, China 518057 t (86-755) 26012053 f (86-755) 26710594 www.sgs.com.cn  
 中国·广东·深圳市南山区科技园中区M-10栋1号厂房 邮编: 518057 t (86-755) 26012053 f (86-755) 26710594 sgs.china@sgs.com

Polarity: Vertical; Modulation:802.11ax(Full RU0); Bandwidth:80MHz; Channel:High

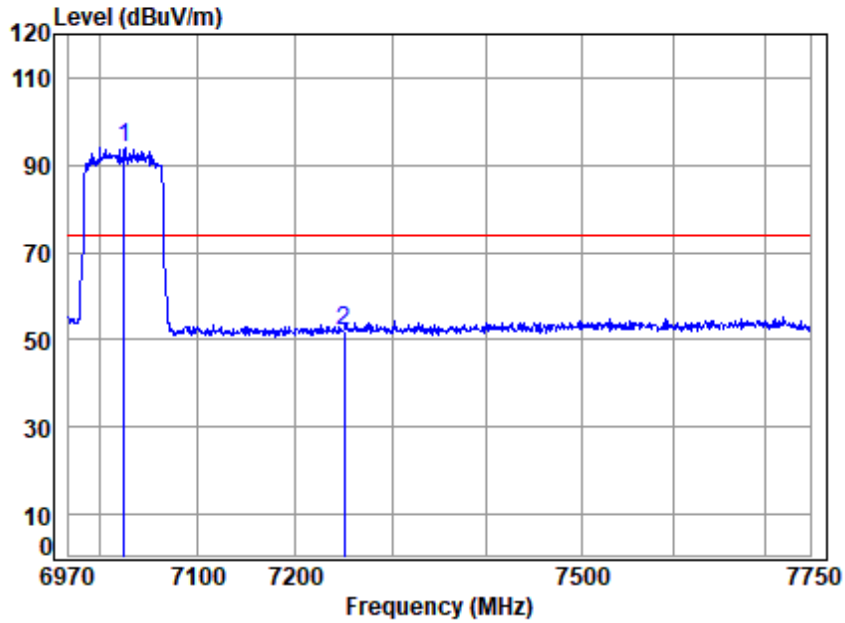

Site : chamber  
 Condition: 3m VERTICAL  
 Job No : 00384AT/00385AT  
 Mode : 7025 Band edge  
 : 5G WIFI 11AX80

	Cable	Ant	Preamp	Read	Limit	Over	
Freq	Loss	Factor	Factor	Level	Level	Line	Limit Remark
MHz	dB	dB/m	dB	dBuV	dBuV/m	dBuV/m	dB
1 p 7025.000	8.95	35.70	35.60	85.14	94.19	74.00	20.19 Peak
2 7250.000	9.23	35.70	35.83	43.05	52.15	74.00	-21.85 Peak



Unless otherwise agreed in writing, this document is issued by the Company subject to its General Conditions of Service printed overleaf, available on request or accessible at <https://www.sgs.com/en/Terms-and-Conditions>. Attention is drawn to the limitation of liability, indemnification and jurisdiction issues defined therein. Any holder of this document is advised that information contained hereon reflects the Company's findings at the time of its intervention only and within the limits of Client's instructions, if any. The Company's sole responsibility is to its Client and this document does not exonerate parties to a transaction from exercising all their rights and obligations under the transaction documents. This document cannot be reproduced except in full, without prior written approval of the Company. Any unauthorized alteration, forgery or falsification of the content or appearance of this document is unlawful and offenders may be prosecuted to the fullest extent of the law. Unless otherwise stated the results shown in this test report refer only to the sample(s) tested and such sample(s) are retained for 30 days only.

Attention: To check the authenticity of testing /inspection report & certificate, please contact us at telephone: (86-755) 8307 1443, or email: CN.Doccheck@sgs.com  
 No.1 Workshop, M-10, Middle Section, Science & Technology Park, Nanshan District, Shenzhen, Guangdong, China 518057 t (86-755) 26012053 f (86-755) 26710594 www.sgs.com.cn  
 中国·广东·深圳市南山区科技园中区M-10栋1号厂房 邮编: 518057 t (86-755) 26012053 f (86-755) 26710594 sgs.china@sgs.com

Polarity: Vertical; Modulation:802.11ax(Full RU0); Bandwidth:80MHz; Channel:High

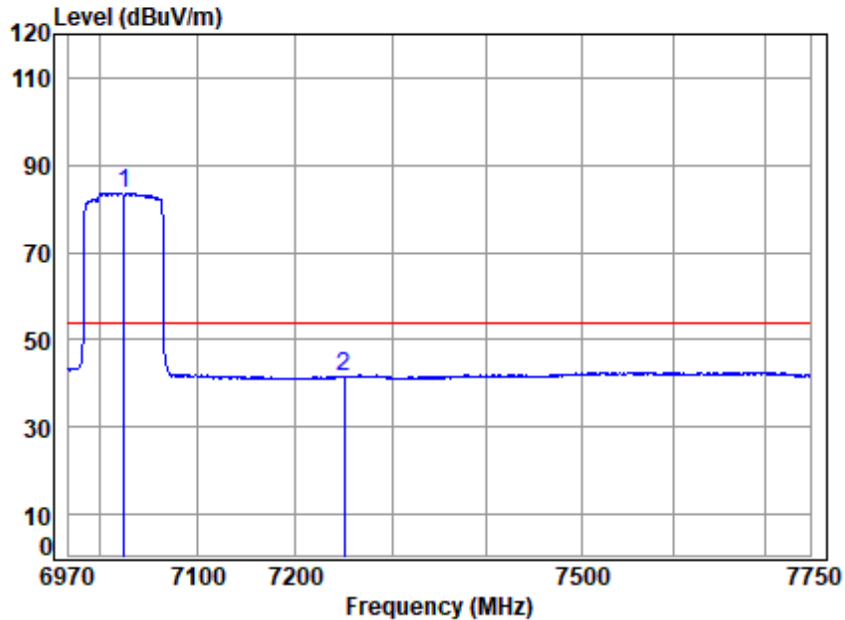

Site : chamber  
 Condition: 3m VERTICAL  
 Job No : 00384AT/00385AT  
 Mode : 7025 Band edge  
 : 5G WIFI 11AX80

	Cable	Ant	Preamp	Read	Limit	Over		
Freq	Loss	Factor	Factor	Level	Line	Limit	Remark	
MHz	dB	dB/m	dB	dBuV	dBuV/m	dBuV/m	dB	
1 q 7025.000	8.95	35.70	35.60	74.67	83.72	54.00	29.72	Average
2 7250.000	9.23	35.70	35.83	32.37	41.47	54.00	-12.53	Average



Unless otherwise agreed in writing, this document is issued by the Company subject to its General Conditions of Service printed overleaf, available on request or accessible at <https://www.sgs.com/en/Terms-and-Conditions>. Attention is drawn to the limitation of liability, indemnification and jurisdiction issues defined therein. Any holder of this document is advised that information contained hereon reflects the Company's findings at the time of its intervention only and within the limits of Client's instructions, if any. The Company's sole responsibility is to its Client and this document does not exonerate parties to a transaction from exercising all their rights and obligations under the transaction documents. This document cannot be reproduced except in full, without prior written approval of the Company. Any unauthorized alteration, forgery or falsification of the content or appearance of this document is unlawful and offenders may be prosecuted to the fullest extent of the law. Unless otherwise stated the results shown in this test report refer only to the sample(s) tested and such sample(s) are retained for 30 days only.

Attention: To check the authenticity of testing /inspection report & certificate, please contact us at telephone: (86-755) 8307 1443, or email: CN.Doccheck@sgs.com

No.1 Workshop, M-10, Middle Section, Science & Technology Park, Nanshan District, Shenzhen, Guangdong, China 518057 t (86-755) 26012053 f (86-755) 26710594 www.sgsgroup.com.cn  
 中国·广东·深圳市南山区科技园中区M-10栋1号厂房 邮编: 518057 t (86-755) 26012053 f (86-755) 26710594 sgs.china@sgs.com



Polarity: Horizontal; Modulation:802.11ax(Full RU0); Bandwidth:160MHz; Channel:Low

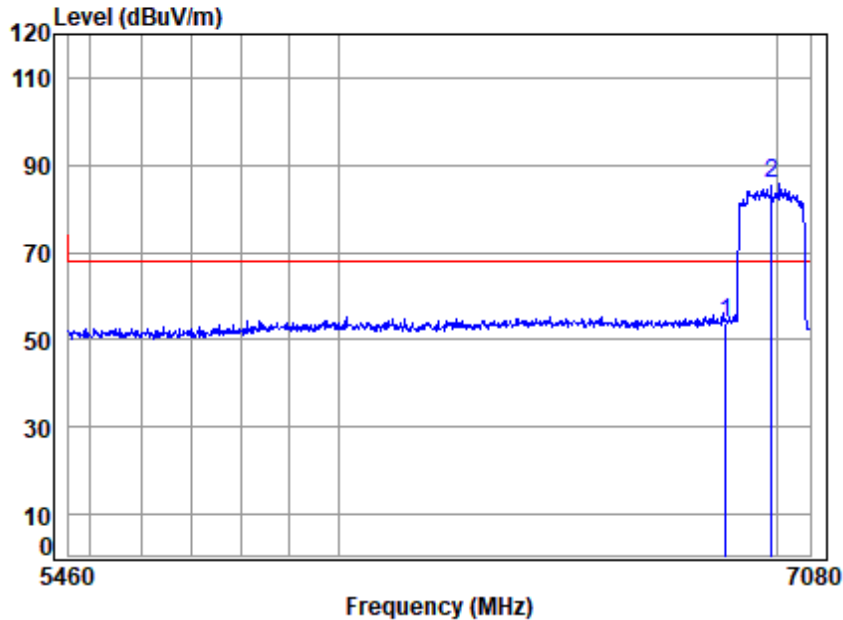

Site : chamber  
 Condition: 3m HORIZONTAL  
 Job No : 00384AT/00385AT  
 Mode : 6985 Band edge  
 : 5G WIFI 11AX160

	Cable	Ant	Preamp	Read	Limit	Over	
Freq	Loss	Factor	Factor	Level	Level	Line	Limit Remark
MHz	dB	dB/m	dB	dBuV	dBuV/m	dBuV/m	dB
1 6875.000	8.83	35.55	35.49	45.07	53.96	68.20	-14.24 peak
2 p 6985.000	8.91	35.73	35.56	76.63	85.71	68.20	17.51 peak



Unless otherwise agreed in writing, this document is issued by the Company subject to its General Conditions of Service printed overleaf, available on request or accessible at <https://www.sgs.com/en/Terms-and-Conditions>. Attention is drawn to the limitation of liability, indemnification and jurisdiction issues defined therein. Any holder of this document is advised that information contained hereon reflects the Company's findings at the time of its intervention only and within the limits of Client's instructions, if any. The Company's sole responsibility is to its Client and this document does not exonerate parties to a transaction from exercising all their rights and obligations under the transaction documents. This document cannot be reproduced except in full, without prior written approval of the Company. Any unauthorized alteration, forgery or falsification of the content or appearance of this document is unlawful and offenders may be prosecuted to the fullest extent of the law. Unless otherwise stated the results shown in this test report refer only to the sample(s) tested and such sample(s) are retained for 30 days only.

Attention: To check the authenticity of testing /inspection report & certificate, please contact us at telephone: (86-755) 8307 1443, or email: CN.Doccheck@sgs.com  
 No.1 Workshop, M-10, Middle Section, Science & Technology Park, Nanshan District, Shenzhen, Guangdong, China 518057 t (86-755) 26012053 f (86-755) 26710594 www.sgs.com.cn  
 中国·广东·深圳市南山区科技园中区M-10栋1号厂房 邮编: 518057 t (86-755) 26012053 f (86-755) 26710594 sgs.china@sgs.com

Polarity: Vertical; Modulation:802.11ax(Full RU0); Bandwidth:160MHz; Channel:Low

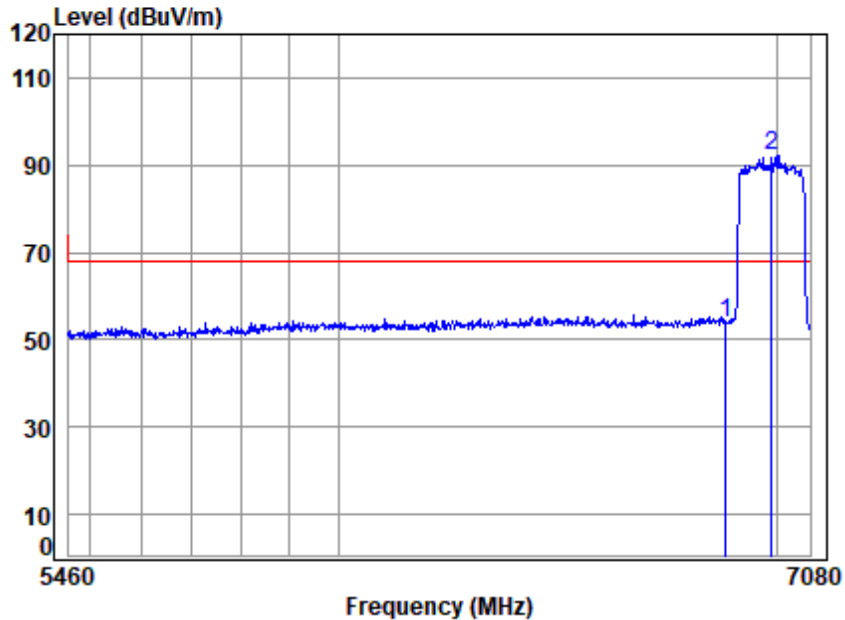

Site : chamber  
 Condition: 3m VERTICAL  
 Job No : 00384AT/00385AT  
 Mode : 6985 Band edge  
 : 5G WIFI 11AX160

	Cable	Ant	Preamp	Read	Limit	Over	
Freq	Loss	Factor	Factor	Level	Level	Line	Limit Remark
MHz	dB	dB/m	dB	dBuV	dBuV/m	dBuV/m	dB
1	6875.000	8.83	35.55	35.49	45.12	54.01	68.20 -14.19 peak
2 p	6985.000	8.91	35.73	35.56	82.95	92.03	68.20 23.83 peak



Unless otherwise agreed in writing, this document is issued by the Company subject to its General Conditions of Service printed overleaf, available on request or accessible at <https://www.sgs.com/en/Terms-and-Conditions>. Attention is drawn to the limitation of liability, indemnification and jurisdiction issues defined therein. Any holder of this document is advised that information contained hereon reflects the Company's findings at the time of its intervention only and within the limits of Client's instructions, if any. The Company's sole responsibility is to its Client and this document does not exonerate parties to a transaction from exercising all their rights and obligations under the transaction documents. This document cannot be reproduced except in full, without prior written approval of the Company. Any unauthorized alteration, forgery or falsification of the content or appearance of this document is unlawful and offenders may be prosecuted to the fullest extent of the law. Unless otherwise stated the results shown in this test report refer only to the sample(s) tested and such sample(s) are retained for 30 days only.

Attention: To check the authenticity of testing /inspection report & certificate, please contact us at telephone: (86-755) 8307 1443, or email: CN.Doccheck@sgs.com  
 No.1 Workshop, M-10, Middle Section, Science & Technology Park, Nanshan District, Shenzhen, Guangdong, China 518057 t (86-755) 26012053 f (86-755) 26710594 www.sgs.com.cn  
 中国·广东·深圳市南山区科技园中区M-10栋1号厂房 邮编: 518057 t (86-755) 26012053 f (86-755) 26710594 sgs.china@sgs.com

Polarity: Horizontal; Modulation:802.11ax(Full RU0); Bandwidth:160MHz; Channel:High

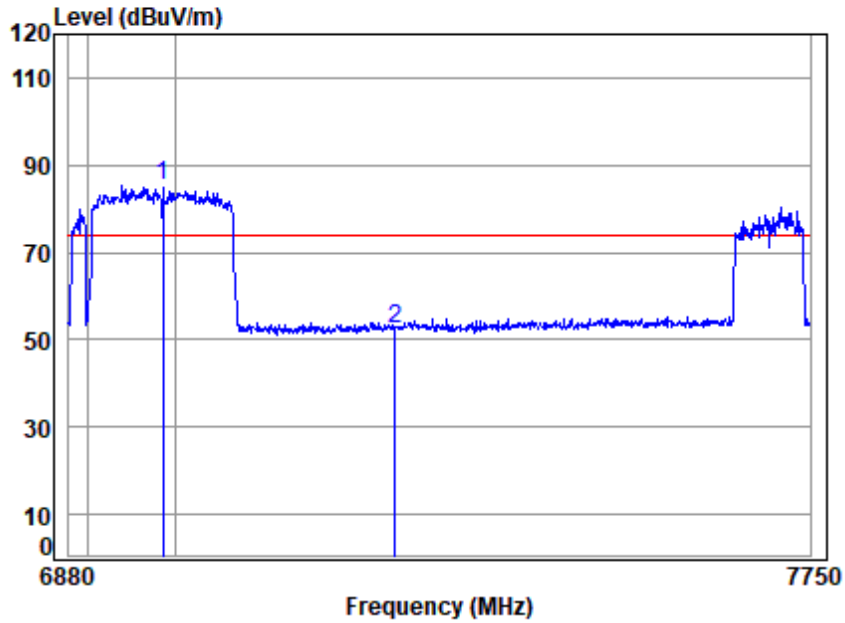

Site : chamber  
 Condition: 3m HORIZONTAL  
 Job No : 00384AT/00385AT  
 Mode : 6985 Band edge  
 : 5G WIFI 11AX160

	Cable	Ant	Preamp	Read	Limit	Over	
Freq	Loss	Factor	Factor	Level	Level	Line	Limit Remark
MHz	dB	dB/m	dB	dBuV	dBuV/m	dBuV/m	dB
1 p 6985.000	8.91	35.73	35.56	76.44	85.52	74.00	11.52 peak
2 7250.000	9.23	35.70	35.83	43.59	52.69	74.00	-21.31 peak



Unless otherwise agreed in writing, this document is issued by the Company subject to its General Conditions of Service printed overleaf, available on request or accessible at <https://www.sgs.com/en/Terms-and-Conditions>. Attention is drawn to the limitation of liability, indemnification and jurisdiction issues defined therein. Any holder of this document is advised that information contained hereon reflects the Company's findings at the time of its intervention only and within the limits of Client's instructions, if any. The Company's sole responsibility is to its Client and this document does not exonerate parties to a transaction from exercising all their rights and obligations under the transaction documents. This document cannot be reproduced except in full, without prior written approval of the Company. Any unauthorized alteration, forgery or falsification of the content or appearance of this document is unlawful and offenders may be prosecuted to the fullest extent of the law. Unless otherwise stated the results shown in this test report refer only to the sample(s) tested and such sample(s) are retained for 30 days only.

Attention: To check the authenticity of testing /inspection report & certificate, please contact us at telephone: (86-755) 8307 1443, or email: CN.Doccheck@sgs.com  
 No.1 Workshop, M-10, Middle Section, Science & Technology Park, Nanshan District, Shenzhen, Guangdong, China 518057 t (86-755) 26012053 f (86-755) 26710594 www.sgs.com.cn  
 中国·广东·深圳市南山区科技园中区M-10栋1号厂房 邮编: 518057 t (86-755) 26012053 f (86-755) 26710594 sgs.china@sgs.com

Polarity: Horizontal; Modulation:802.11ax(Full RU0); Bandwidth:160MHz; Channel:High

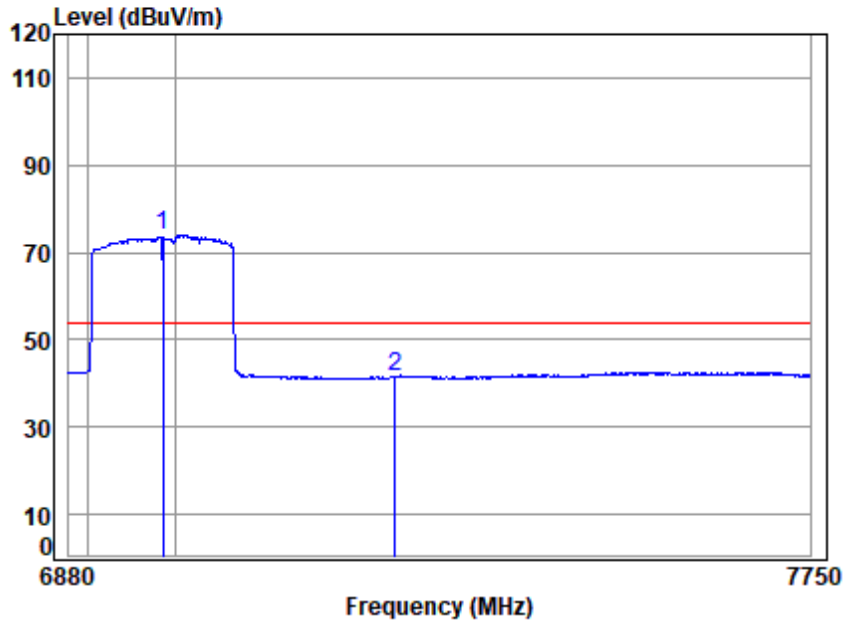

Site : chamber  
 Condition: 3m HORIZONTAL  
 Job No : 00384AT/00385AT  
 Mode : 6985 Band edge  
 : 5G WIFI 11AX160

		Cable	Ant	Preamp	Read	Limit	Over	
	Freq	Loss	Factor	Factor	Level	Line	Limit	Remark
	MHz	dB	dB/m	dB	dBuV	dBuV/m	dBuV/m	dB
1	q 6985.000	8.91	35.73	35.56	64.98	74.06	54.00	20.06 Average
2	7250.000	9.23	35.70	35.83	32.42	41.52	54.00	-12.48 Average



Unless otherwise agreed in writing, this document is issued by the Company subject to its General Conditions of Service printed overleaf, available on request or accessible at <https://www.sgs.com/en/Terms-and-Conditions>. Attention is drawn to the limitation of liability, indemnification and jurisdiction issues defined therein. Any holder of this document is advised that information contained hereon reflects the Company's findings at the time of its intervention only and within the limits of Client's instructions, if any. The Company's sole responsibility is to its Client and this document does not exonerate parties to a transaction from exercising all their rights and obligations under the transaction documents. This document cannot be reproduced except in full, without prior written approval of the Company. Any unauthorized alteration, forgery or falsification of the content or appearance of this document is unlawful and offenders may be prosecuted to the fullest extent of the law. Unless otherwise stated the results shown in this test report refer only to the sample(s) tested and such sample(s) are retained for 30 days only.

Attention: To check the authenticity of testing /inspection report & certificate, please contact us at telephone: (86-755) 8307 1443, or email: CN.Doccheck@sgs.com  
 No.1 Workshop, M-10, Middle Section, Science & Technology Park, Nanshan District, Shenzhen, Guangdong, China 518057 t (86-755) 26012053 f (86-755) 26710594 www.sgs.com.cn  
 中国·广东·深圳市南山区科技园中区M-10栋1号厂房 邮编: 518057 t (86-755) 26012053 f (86-755) 26710594 sgs.china@sgs.com



Polarity: Vertical; Modulation:802.11ax(Full RU0); Bandwidth:160MHz; Channel:High

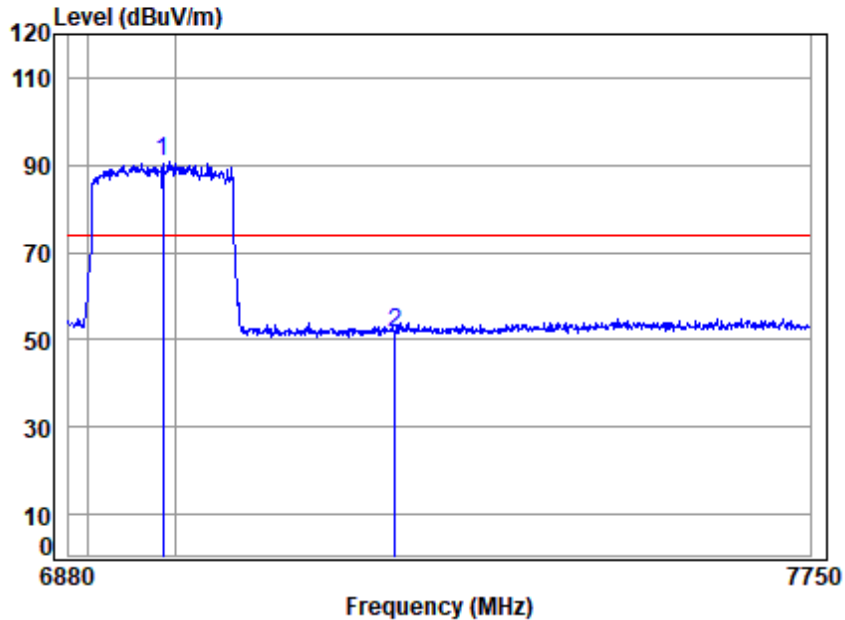

Site : chamber  
 Condition: 3m VERTICAL  
 Job No : 00384AT/00385AT  
 Mode : 6985 Band edge  
 : 5G WIFI 11AX160

	Cable	Ant	Preamp	Read	Limit	Over	
Freq	Loss	Factor	Factor	Level	Level	Line	Limit Remark
MHz	dB	dB/m	dB	dBuV	dBuV/m	dBuV/m	dB
1 p 6985.000	8.91	35.73	35.56	81.90	90.98	74.00	16.98 Peak
2 7250.000	9.23	35.70	35.83	42.56	51.66	74.00	-22.34 Peak



Unless otherwise agreed in writing, this document is issued by the Company subject to its General Conditions of Service printed overleaf, available on request or accessible at <https://www.sgs.com/en/Terms-and-Conditions>. Attention is drawn to the limitation of liability, indemnification and jurisdiction issues defined therein. Any holder of this document is advised that information contained hereon reflects the Company's findings at the time of its intervention only and within the limits of Client's instructions, if any. The Company's sole responsibility is to its Client and this document does not exonerate parties to a transaction from exercising all their rights and obligations under the transaction documents. This document cannot be reproduced except in full, without prior written approval of the Company. Any unauthorized alteration, forgery or falsification of the content or appearance of this document is unlawful and offenders may be prosecuted to the fullest extent of the law. Unless otherwise stated the results shown in this test report refer only to the sample(s) tested and such sample(s) are retained for 30 days only.

Attention: To check the authenticity of testing /inspection report & certificate, please contact us at telephone: (86-755) 8307 1443, or email: CN.Doccheck@sgs.com  
 No.1 Workshop, M-10, Middle Section, Science & Technology Park, Nanshan District, Shenzhen, Guangdong, China 518057 t (86-755) 26012053 f (86-755) 26710594 www.sgs.com.cn  
 中国·广东·深圳市南山区科技园中区M-10栋1号厂房 邮编: 518057 t (86-755) 26012053 f (86-755) 26710594 sgs.china@sgs.com

Polarity: Vertical; Modulation:802.11ax(Full RU0); Bandwidth:160MHz; Channel:High

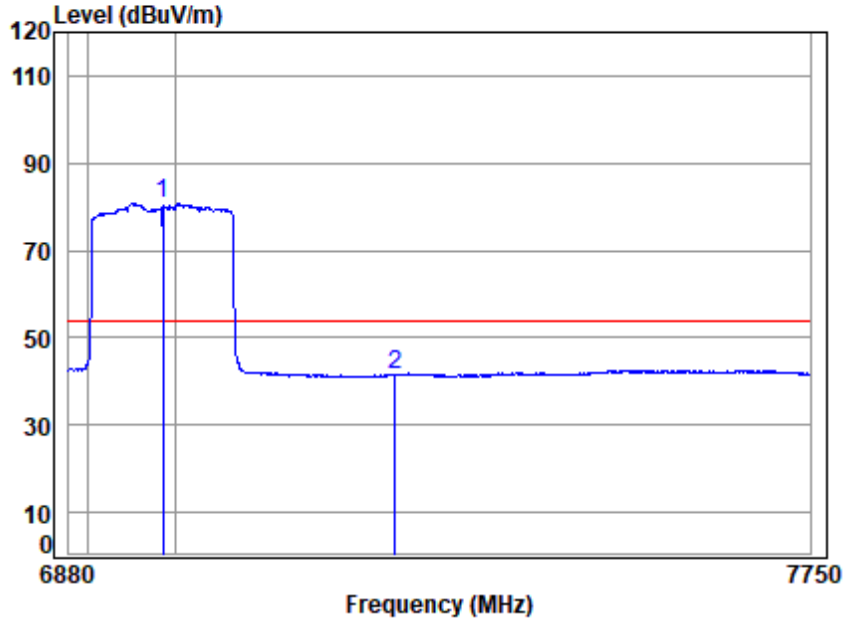

Site : chamber  
 Condition: 3m VERTICAL  
 Job No : 00384AT/00385AT  
 Mode : 6985 Band edge  
 : 5G WIFI 11AX160

	Cable	Ant	Preamp	Read	Limit	Over		
Freq	Loss	Factor	Factor	Level	Level	Line	Limit	Remark
MHz	dB	dB/m	dB	dBuV	dBuV/m	dBuV/m	dB	
1 q 6985.000	8.91	35.73	35.56	71.65	80.73	54.00	26.73	Average
2 7250.000	9.23	35.70	35.83	32.34	41.44	54.00	-12.56	Average



Unless otherwise agreed in writing, this document is issued by the Company subject to its General Conditions of Service printed overleaf, available on request or accessible at <https://www.sgs.com/en/Terms-and-Conditions>. Attention is drawn to the limitation of liability, indemnification and jurisdiction issues defined therein. Any holder of this document is advised that information contained hereon reflects the Company's findings at the time of its intervention only and within the limits of Client's instructions, if any. The Company's sole responsibility is to its Client and this document does not exonerate parties to a transaction from exercising all their rights and obligations under the transaction documents. This document cannot be reproduced except in full, without prior written approval of the Company. Any unauthorized alteration, forgery or falsification of the content or appearance of this document is unlawful and offenders may be prosecuted to the fullest extent of the law. Unless otherwise stated the results shown in this test report refer only to the sample(s) tested and such sample(s) are retained for 30 days only.

Attention: To check the authenticity of testing /inspection report & certificate, please contact us at telephone: (86-755) 8307 1443, or email: CN.Doccheck@sgs.com  
 No.1 Workshop, M-10, Middle Section, Science & Technology Park, Nanshan District, Shenzhen, Guangdong, China 518057 t (86-755) 26012053 f (86-755) 26710594 www.sgsgroup.com.cn  
 中国·广东·深圳市南山区科技园中区M-10栋1号厂房 邮编: 518057 t (86-755) 26012053 f (86-755) 26710594 sgs.china@sgs.com

**7.11 Contention-based Protocol**

Test Requirement 47 CFR Part 15, Subpart E 15.407 (d)(6)  
 Test Method: KDB 987594 D02 U-NII 6GHz EMC Measurement v02r01

Limit:

Unlicensed low-power indoor devices must detect co-channel radio frequency power that is at least -62 dBm or lower. Upon detection of energy in the band, unlicensed low power indoor devices must vacate the channel (in which incumbent signal is transmitted) and stay off the incumbent channel as long as detected radio frequency power is equal to or greater than the threshold (-62 dBm). The -62 dBm (or lower) threshold is referenced to a 0 dBi antenna gain. To ensure incumbent operations are reliably detected in the band, low power indoor devices must detect RF energy throughout their intended operating channel. For example, an 802.11 device that plans to transmit a 40 MHz- wide signal (on a primary 20 MHz channel and a secondary 20 MHz channel) must detect energy throughout the entire 40 MHz channel. Additionally, low-power indoor devices must detect co-channel energy with 90% or greater certainty.

**7.11.1 E.U.T. Operation**

Operating Environment:  
 Temperature: 21.8 °C Humidity: 54.9 % RH Atmospheric Pressure: 1020 mbar

**7.11.2 Test Mode Description**

Pre-scan / Final test	Mode Code	Description
Final test	01	TX mode (U-NII-5) _ Keep the EUT in continuously transmitting mode with all modulation types. Data rate @ MCS0 is the worst case of IEEE 802.11a/ax 20/160, Only the data of worst case is recorded in the report.
Final test	02	TX mode (U-NII-6) _ Keep the EUT in continuously transmitting mode with all modulation types. Data rate @ MCS0 is the worst case of IEEE 802.11a/ax 20/160, Only the data of worst case is recorded in the report.
Final test	03	TX mode (U-NII-7) _ Keep the EUT in continuously transmitting mode with all modulation types. Data rate @ MCS0 is the worst case of IEEE 802.11a/ax 20/160, Only the data of worst case is recorded in the report.
Final test	04	TX mode (U-NII-8) _ Keep the EUT in continuously transmitting mode with all modulation types. Data rate @ MCS0 is the worst case of IEEE 802.11a/ax 20/160, Only the data of worst case is recorded in the report.



Unless otherwise agreed in writing, this document is issued by the Company subject to its General Conditions of Service printed overleaf, available on request or accessible at <https://www.sgs.com/en/Terms-and-Conditions>. Attention is drawn to the limitation of liability, indemnification and jurisdiction issues defined therein. Any holder of this document is advised that information contained hereon reflects the Company's findings at the time of its intervention only and within the limits of Client's instructions, if any. The Company's sole responsibility is to its Client and this document does not exonerate parties to a transaction from exercising all their rights and obligations under the transaction documents. This document cannot be reproduced except in full, without prior written approval of the Company. Any unauthorized alteration, forgery or falsification of the content or appearance of this document is unlawful and offenders may be prosecuted to the fullest extent of the law. Unless otherwise stated the results shown in this test report refer only to the sample(s) tested and such sample(s) are retained for 30 days only.  
 Attention: To check the authenticity of testing /inspection report & certificate, please contact us at telephone: (86-755) 8307 1443, or email: CN.Doccheck@sgs.com  
 No.1 Workshop, M-10, Middle Section, Science & Technology Park, Nanshan District, Shenzhen, Guangdong, China 518057 t (86-755) 26012053 f (86-755) 26710594 www.sgsgroup.com.cn  
 中国·广东·深圳市南山区科技园中区M-10栋1号厂房 邮编: 518057 t (86-755) 26012053 f (86-755) 26710594 sgs.china@sgs.com



**7.11.3 Test Setup Diagram**

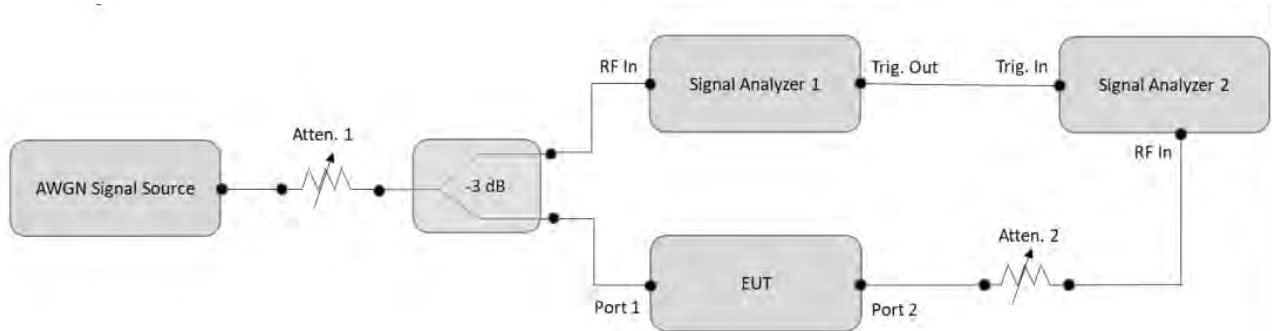

**7.11.4 Measurement Procedure and Data**

1. Configure the EUT to transmit with a constant duty cycle.
2. Set the operating parameters of the EUT including power level, operating frequency, modulation and bandwidth.
3. Set the signal analyzer center frequency to the nominal EUT channel center frequency. The span range of the signal analyzer shall be between two times and five times the OBW of the EUT. Connect the output port of the EUT to the signal analyzer 2, as shown in Figure 2. Ensure that the attenuator 2 provides enough attenuation to not overload the signal analyzer 2 receiver.
4. Monitoring the signal analyzer 2, verify the EUT is operating and transmitting with the parameters set at step two.
5. Using an AWGN signal source, generate (but do not transmit, i.e., RF OFF) a 10 MHz-wide AWGN signal. Use Table 1 to determine the center frequency of the 10 MHz AWGN signal relative to the EUT's channel bandwidth and center frequency.
6. Set the AWGN signal power to an extremely low level (more than 20 dB below the -62 dBm threshold). Connect the AWGN signal source, via a 3-dB splitter, to the signal analyzer 1 and the EUT as shown in Figure 2.
7. Transmit the AWGN signal (RF ON) and verify its characteristics on the signal analyzer 1.
8. Monitor the signal analyzer 2 to verify if the AWGN signal has been detected and the EUT has ceased transmission. If the EUT continues to transmit, then incrementally increase the AWGN signal power level until the EUT stops transmitting.
9. (Including all losses in the RF paths) Determine and record the AWGN signal power level (at the EUT's antenna port) at which the EUT ceased transmission. Repeat the procedure at least 10 times to verify the EUT can detect an AWGN signal with 90% (or better) level of certainty.
10. Refer to Table 1 to determine number of times the detection threshold testing needs to be repeated. If testing is required more than once, then go back to step 5, choose a different center frequency for the AWGN signal and repeat the process.

Please Refer to Appendix for Details



Unless otherwise agreed in writing, this document is issued by the Company subject to its General Conditions of Service printed overleaf, available on request or accessible at <https://www.sgs.com/en/Terms-and-Conditions>. Attention is drawn to the limitation of liability, indemnification and jurisdiction issues defined therein. Any holder of this document is advised that information contained hereon reflects the Company's findings at the time of its intervention only and within the limits of Client's instructions, if any. The Company's sole responsibility is to its Client and this document does not exonerate parties to a transaction from exercising all their rights and obligations under the transaction documents. This document cannot be reproduced except in full, without prior written approval of the Company. Any unauthorized alteration, forgery or falsification of the content or appearance of this document is unlawful and offenders may be prosecuted to the fullest extent of the law. Unless otherwise stated the results shown in this test report refer only to the sample(s) tested and such sample(s) are retained for 30 days only.

Attention: To check the authenticity of testing /inspection report & certificate, please contact us at telephone: (86-755) 8307 1443, or email: CN.Doccheck@sgs.com  
 No.1 Workshop, M-10, Middle Section, Science & Technology Park, Nanshan District, Shenzhen, Guangdong, China 518057 t (86-755) 26012053 f (86-755) 26710594 www.sgs.com.cn  
 中国·广东·深圳市南山区科技园中区M-10栋1号厂房 邮编: 518057 t (86-755) 26012053 f (86-755) 26710594 sgs.china@sgs.com



**7.12 Frequency Stability**

Test Requirement 47 CFR Part 15, Subpart E 15.407 (g)  
 Test Method: ANSI C63.10 (2020) Section 6.8

**7.12.1 E.U.T. Operation**

Operating Environment:  
 Temperature: 21.8 °C Humidity: 54.9 % RH Atmospheric Pressure: 1020 mbar

**7.12.2 Test Mode Description**

Pre-scan / Final test	Mode Code	Description
Final test	01	TX mode (U-NII-5) _ Keep the EUT in continuously transmitting mode with all modulation types. All data rates for each modulation type have been tested and found the data rate @ MCS0 is the worst case of IEEE 802.11a/ax 20/40/80/160, Only the data of worst case is recorded in the report.
Final test	02	TX mode (U-NII-6) _ Keep the EUT in continuously transmitting mode with all modulation types. All data rates for each modulation type have been tested and found the data rate @ MCS0 is the worst case of IEEE 802.11a/ax 20/40/80/160, Only the data of worst case is recorded in the report.
Final test	03	TX mode (U-NII-7) _ Keep the EUT in continuously transmitting mode with all modulation types. All data rates for each modulation type have been tested and found the data rate @ MCS0 is the worst case of IEEE 802.11a/ax 20/40/80/160, Only the data of worst case is recorded in the report.
Final test	04	TX mode (U-NII-8) _ Keep the EUT in continuously transmitting mode with all modulation types. All data rates for each modulation type have been tested and found the data rate @ MCS0 is the worst case of IEEE 802.11a/ax 20/40/80/160, Only the data of worst case is recorded in the report.

**7.12.3 Test Setup Diagram**

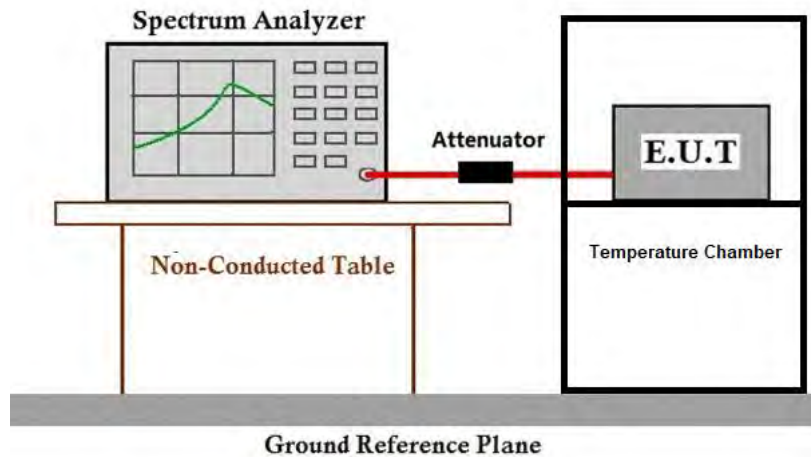

**7.12.4 Measurement Procedure and Data**

Please Refer to Appendix for Details



Unless otherwise agreed in writing, this document is issued by the Company subject to its General Conditions of Service printed overleaf, available on request or accessible at <https://www.sgs.com/en/Terms-and-Conditions>. Attention is drawn to the limitation of liability, indemnification and jurisdiction issues defined therein. Any holder of this document is advised that information contained hereon reflects the Company's findings at the time of its intervention only and within the limits of Client's instructions, if any. The Company's sole responsibility is to its Client and this document does not exonerate parties to a transaction from exercising all their rights and obligations under the transaction documents. This document cannot be reproduced except in full, without prior written approval of the Company. Any unauthorized alteration, forgery or falsification of the content or appearance of this document is unlawful and offenders may be prosecuted to the fullest extent of the law. Unless otherwise stated the results shown in this test report refer only to the sample(s) tested and such sample(s) are retained for 30 days only.  
 Attention: To check the authenticity of testing /inspection report & certificate, please contact us at telephone: (86-755) 8307 1443, or email: CN.Doccheck@sgs.com  
 No.1 Workshop, M-10, Middle Section, Science & Technology Park, Nanshan District, Shenzhen, Guangdong, China 518057 t (86-755) 26012053 f (86-755) 26710594 www.sgsgroup.com.cn  
 中国·广东·深圳市南山区科技园中区M-10栋1号厂房 邮编: 518057 t (86-755) 26012053 f (86-755) 26710594 sgs.china@sgs.com

## 8 Test Setup Photo

Refer to Appendix A.2 WLAN Setup Photos.



Unless otherwise agreed in writing, this document is issued by the Company subject to its General Conditions of Service printed overleaf, available on request or accessible at <https://www.sgs.com/en/Terms-and-Conditions>. Attention is drawn to the limitation of liability, indemnification and jurisdiction issues defined therein. Any holder of this document is advised that information contained hereon reflects the Company's findings at the time of its intervention only and within the limits of Client's instructions, if any. The Company's sole responsibility is to its Client and this document does not exonerate parties to a transaction from exercising all their rights and obligations under the transaction documents. This document cannot be reproduced except in full, without prior written approval of the Company. Any unauthorized alteration, forgery or falsification of the content or appearance of this document is unlawful and offenders may be prosecuted to the fullest extent of the law. Unless otherwise stated the results shown in this test report refer only to the sample(s) tested and such sample(s) are retained for 30 days only.

Attention: To check the authenticity of testing /inspection report & certificate, please contact us at telephone: (86-755) 8307 1443, or email: [CN.Doccheck@sgs.com](mailto:CN.Doccheck@sgs.com)

## 9 Appendix

### 1. Duty Cycle

#### 1.1 Ant1

##### 1.1.1 Test Result

Ant1										
ENV	Mode	TX Type	Frequency (MHz)	RU	RU Pos	T_on (ms)	Period (ms)	Duty Cycle (%)	Duty Cycle Correction Factor (dB)	Max. DC Variation (%)
NTNV	802.11a	MIMO	5955	RU242	Left	2.096	2.112	99.24	0.03	0.03
			6175	RU242	Left	2.097	2.112	99.29	0.03	0.00
			6415	RU242	Left	2.097	2.113	99.24	0.03	0.03
	802.11ax (HE20)	MIMO	5955	RU242	Left	5.428	5.444	99.71	0.01	0.04
			6175	RU242	Left	5.431	5.446	99.72	0.01	0.00
			6415	RU242	Left	5.430	5.445	99.72	0.01	0.00
	802.11ax (HE40)	MIMO	5965	RU484	Left	4.816	4.833	99.65	0.02	0.03
			6165	RU484	Left	4.816	4.831	99.69	0.01	0.00
			6405	RU484	Left	4.816	4.833	99.65	0.02	0.04
	802.11ax (HE80)	MIMO	5985	RU996	Left	2.555	2.570	99.42	0.03	0.03
			6145	RU996	Left	2.555	2.571	99.38	0.03	0.03
			6385	RU996	Left	2.555	2.570	99.42	0.03	0.03
802.11ax (HE160)	MIMO	6025	2xRU996	Left	2.207	2.222	99.32	0.03	0.04	
		6185	2xRU996	Left	2.207	2.222	99.32	0.03	0.04	
		6345	2xRU996	Left	2.208	2.223	99.33	0.03	0.04	

#### 1.2 Ant1

##### 1.2.1 Test Result

Ant1										
ENV	Mode	TX Type	Frequency (MHz)	RU	RU Pos	T_on (ms)	Period (ms)	Duty Cycle (%)	Duty Cycle Correction Factor (dB)	Max. DC Variation (%)
NTNV	802.11a	MIMO	6435	RU242	Left	2.096	2.113	99.20	0.04	0.03
			6475	RU242	Left	2.097	2.113	99.24	0.03	0.03
			6515	RU242	Left	2.096	2.113	99.20	0.04	0.07
	802.11ax	MIMO	6435	RU242	Left	5.430	5.446	99.71	0.01	0.04



Unless otherwise agreed in writing, this document is issued by the Company subject to its General Conditions of Service printed overleaf, available on request or accessible at <https://www.sgs.com/en/Terms-and-Conditions>. Attention is drawn to the limitation of liability, indemnification and jurisdiction issues defined therein. Any holder of this document is advised that information contained hereon reflects the Company's findings at the time of its intervention only and within the limits of Client's instructions, if any. The Company's sole responsibility is to its Client and this document does not exonerate parties to a transaction from exercising all their rights and obligations under the transaction documents. This document cannot be reproduced except in full, without prior written approval of the Company. Any unauthorized alteration, forgery or falsification of the content or appearance of this document is unlawful and offenders may be prosecuted to the fullest extent of the law. Unless otherwise stated the results shown in this test report refer only to the sample(s) tested and such sample(s) are retained for 30 days only.

Attention: To check the authenticity of testing /inspection report & certificate, please contact us at telephone: (86-755) 8307 1443, or email: CN.Doccheck@sgs.com

SGS-CSTC Standards Technical Services Co., Ltd. Shenzhen Branch Laboratory  
 No.1 Workshop, M-10, Middle Section, Science & Technology Park, Nanshan District, Shenzhen, Guangdong, China 518057 t (86-755) 26012053 f (86-755) 26710594 www.sgs.com.cn  
 中国·广东·深圳市南山区科技园中区M-10栋1号厂房 邮编: 518057 t (86-755) 26012053 f (86-755) 26710594 sgs.china@sgs.com

	(HE20)		6475	RU242	Left	5.428	5.445	99.69	0.01	0.00
			6515	RU242	Left	5.428	5.444	99.71	0.01	0.04
	802.11ax (HE40)	MIMO	6445	RU484	Left	4.817	4.834	99.65	0.02	0.03
			6485	RU484	Left	4.817	4.832	99.69	0.01	0.00
802.11ax (HE80)	MIMO	6465	RU996	Left	2.555	2.571	99.38	0.03	0.03	

1.3 Ant1

1.3.1 Test Result

Ant1										
ENV	Mode	TX Type	Frequency (MHz)	RU	RU Pos	T <sub>on</sub> (ms)	Period (ms)	Duty Cycle (%)	Duty Cycle Correction Factor (dB)	Max. DC Variation (%)
NTNV	802.11a	MIMO	6535	RU242	Left	2.098	2.114	99.24	0.03	0.03
			6695	RU242	Left	2.097	2.113	99.24	0.03	0.03
			6855	RU242	Left	2.096	2.112	99.24	0.03	0.03
	802.11ax (HE20)	MIMO	6535	RU242	Left	5.428	5.444	99.71	0.01	0.04
			6695	RU242	Left	5.428	5.445	99.69	0.01	0.03
			6855	RU242	Left	5.430	5.445	99.72	0.01	0.00
	802.11ax (HE40)	MIMO	6565	RU484	Left	4.817	4.832	99.69	0.01	0.00
			6685	RU484	Left	4.816	4.831	99.69	0.01	0.00
			6845	RU484	Left	4.817	4.834	99.65	0.02	0.03
	802.11ax (HE80)	MIMO	6625	RU996	Left	2.555	2.571	99.38	0.03	0.03
			6705	RU996	Left	2.555	2.571	99.38	0.03	0.03
			6785	RU996	Left	2.555	2.571	99.38	0.03	0.04
	802.11ax (HE160)	MIMO	6665	2xRU996	Left	2.207	2.222	99.32	0.03	0.04

1.4 Ant1

1.4.1 Test Result

Ant1										
ENV	Mode	TX Type	Frequency (MHz)	RU	RU Pos	T <sub>on</sub> (ms)	Period (ms)	Duty Cycle (%)	Duty Cycle Correction Factor (dB)	Max. DC Variation (%)
NTNV	802.11a	MIMO	6895	RU242	Left	2.096	2.113	99.20	0.04	0.07
			6995	RU242	Left	2.098	2.114	99.24	0.03	0.03
			7115	RU242	Left	2.098	2.114	99.24	0.03	0.03
	802.11ax	MIMO	6895	RU242	Left	5.431	5.445	99.74	0.01	0.00



Unless otherwise agreed in writing, this document is issued by the Company subject to its General Conditions of Service printed overleaf, available on request or accessible at <https://www.sgs.com/en/Terms-and-Conditions>. Attention is drawn to the limitation of liability, indemnification and jurisdiction issues defined therein. Any holder of this document is advised that information contained hereon reflects the Company's findings at the time of its intervention only and within the limits of Client's instructions, if any. The Company's sole responsibility is to its Client and this document does not exonerate parties to a transaction from exercising all their rights and obligations under the transaction documents. This document cannot be reproduced except in full, without prior written approval of the Company. Any unauthorized alteration, forgery or falsification of the content or appearance of this document is unlawful and offenders may be prosecuted to the fullest extent of the law. Unless otherwise stated the results shown in this test report refer only to the sample(s) tested and such sample(s) are retained for 30 days only.

Attention: To check the authenticity of testing /inspection report & certificate, please contact us at telephone: (86-755) 8307 1443, or email: CN.Doccheck@sgs.com

SGS-CSTC Standards Technical Services Co., Ltd. Shenzhen Branch Laboratory  
 No.1 Workshop, M-10, Middle Section, Science & Technology Park, Nanshan District, Shenzhen, Guangdong, China 518057 t (86-755) 26012053 f (86-755) 26710594 www.sgs.com.cn  
 中国·广东·深圳市南山区科技园中区M-10栋1号厂房 邮编: 518057 t (86-755) 26012053 f (86-755) 26710594 sgs.china@sgs.com



(HE20)		6995	RU242	Left	5.428	5.444	99.71	0.01	0.04
		7115	RU242	Left	5.428	5.444	99.71	0.01	0.04
802.11ax (HE40)	MIMO	6925	RU484	Left	4.817	4.832	99.69	0.01	0.00
		7005	RU484	Left	4.817	4.832	99.69	0.01	0.00
		7085	RU484	Left	4.817	4.832	99.69	0.01	0.00
802.11ax (HE80)	MIMO	6945	RU996	Left	2.555	2.570	99.42	0.03	0.00
		7025	RU996	Left	2.555	2.571	99.38	0.03	0.03
802.11ax (HE160)	MIMO	6985	2xRU996	Left	2.207	2.222	99.32	0.03	0.04

1.5 Ant1

1.5.1 Test Result

Ant1										
ENV	Mode	TX Type	Frequency (MHz)	RU	RU Pos	T_on (ms)	Period (ms)	Duty Cycle (%)	Duty Cycle Correction Factor (dB)	Max. DC Variation (%)
NTNV	802.11a	MIMO	6875	RU242	Left	2.097	2.112	99.29	0.03	0.03
	802.11ax (HE20)	MIMO	6875	RU242	Left	5.428	5.444	99.71	0.01	0.04
	802.11ax (HE40)	MIMO	6885	RU484	Left	4.816	4.831	99.69	0.01	0.00
	802.11ax (HE80)	MIMO	6865	RU996	Left	2.555	2.571	99.38	0.03	0.03
	802.11ax (HE160)	MIMO	6825	2xRU996	Left	2.207	2.223	99.28	0.03	0.04

1.6 Ant1

1.6.1 Test Result

Ant1										
ENV	Mode	TX Type	Frequency (MHz)	RU	RU Pos	T_on (ms)	Period (ms)	Duty Cycle (%)	Duty Cycle Correction Factor (dB)	Max. DC Variation (%)
NTNV	802.11ax (HE40)	MIMO	6525	RU484	Left	4.817	4.833	99.67	0.01	0.03
	802.11ax (HE80)	MIMO	6545	RU996	Left	2.556	2.570	99.46	0.02	0.04
	802.11ax (HE160)	MIMO	6505	2xRU996	Left	2.208	2.223	99.33	0.03	0.04



Unless otherwise agreed in writing, this document is issued by the Company subject to its General Conditions of Service printed overleaf, available on request or accessible at <https://www.sgs.com/en/Terms-and-Conditions>. Attention is drawn to the limitation of liability, indemnification and jurisdiction issues defined therein. Any holder of this document is advised that information contained hereon reflects the Company's findings at the time of its intervention only and within the limits of Client's instructions, if any. The Company's sole responsibility is to its Client and this document does not exonerate parties to a transaction from exercising all their rights and obligations under the transaction documents. This document cannot be reproduced except in full, without prior written approval of the Company. Any unauthorized alteration, forgery or falsification of the content or appearance of this document is unlawful and offenders may be prosecuted to the fullest extent of the law. Unless otherwise stated the results shown in this test report refer only to the sample(s) tested and such sample(s) are retained for 30 days only.

Attention: To check the authenticity of testing /inspection report & certificate, please contact us at telephone: (86-755) 8307 1443, or email: CN.Doccheck@sgs.com

SGS-CSTC Standards Technical Services Co., Ltd. Shenzhen Branch Laboratory  
 No.1 Workshop, M-10, Middle Section, Science & Technology Park, Nanshan District, Shenzhen, Guangdong, China 518057 t (86-755) 26012053 f (86-755) 26710594 www.sgs.com.cn  
 中国·广东·深圳市南山区科技园中区M-10栋1号厂房 邮编: 518057 t (86-755) 26012053 f (86-755) 26710594 sgs.china@sgs.com

## 2. Bandwidth

### 2.1 OBW

#### 2.1.1 Test Result

ENV	Mode	TX Type	Frequency (MHz)	RU	RU Pos	ANT	99% Occupied Bandwidth (MHz)		Verdict
							Result	Limit	
NTNV	802.11ax (HE20)	MIMO	5955	RU242	Left	1	19.073	<=160	Pass
			6175	RU242	Left	1	19.085	<=160	Pass
			6415	RU242	Left	1	19.097	<=160	Pass
	802.11ax (HE40)	MIMO	5965	RU484	Left	1	37.981	<=160	Pass
			6165	RU484	Left	1	37.938	<=160	Pass
			6405	RU484	Left	1	37.986	<=160	Pass
	802.11ax (HE80)	MIMO	5985	RU996	Left	1	77.628	<=160	Pass
			6145	RU996	Left	1	77.454	<=160	Pass
			6385	RU996	Left	1	77.558	<=160	Pass
	802.11ax (HE160)	MIMO	6025	2xRU996	Left	1	156.739	<=160	Pass
			6185	2xRU996	Left	1	156.926	<=160	Pass
			6345	2xRU996	Left	1	156.061	<=160	Pass



Unless otherwise agreed in writing, this document is issued by the Company subject to its General Conditions of Service printed overleaf, available on request or accessible at <https://www.sgs.com/en/Terms-and-Conditions>. Attention is drawn to the limitation of liability, indemnification and jurisdiction issues defined therein. Any holder of this document is advised that information contained hereon reflects the Company's findings at the time of its intervention only and within the limits of Client's instructions, if any. The Company's sole responsibility is to its Client and this document does not exonerate parties to a transaction from exercising all their rights and obligations under the transaction documents. This document cannot be reproduced except in full, without prior written approval of the Company. Any unauthorized alteration, forgery or falsification of the content or appearance of this document is unlawful and offenders may be prosecuted to the fullest extent of the law. Unless otherwise stated the results shown in this test report refer only to the sample(s) tested and such sample(s) are retained for 30 days only.

Attention: To check the authenticity of testing /inspection report & certificate, please contact us at telephone: (86-755) 8307 1443, or email: [CN.Doccheck@sgs.com](mailto:CN.Doccheck@sgs.com)

2.1.2 Test Graph

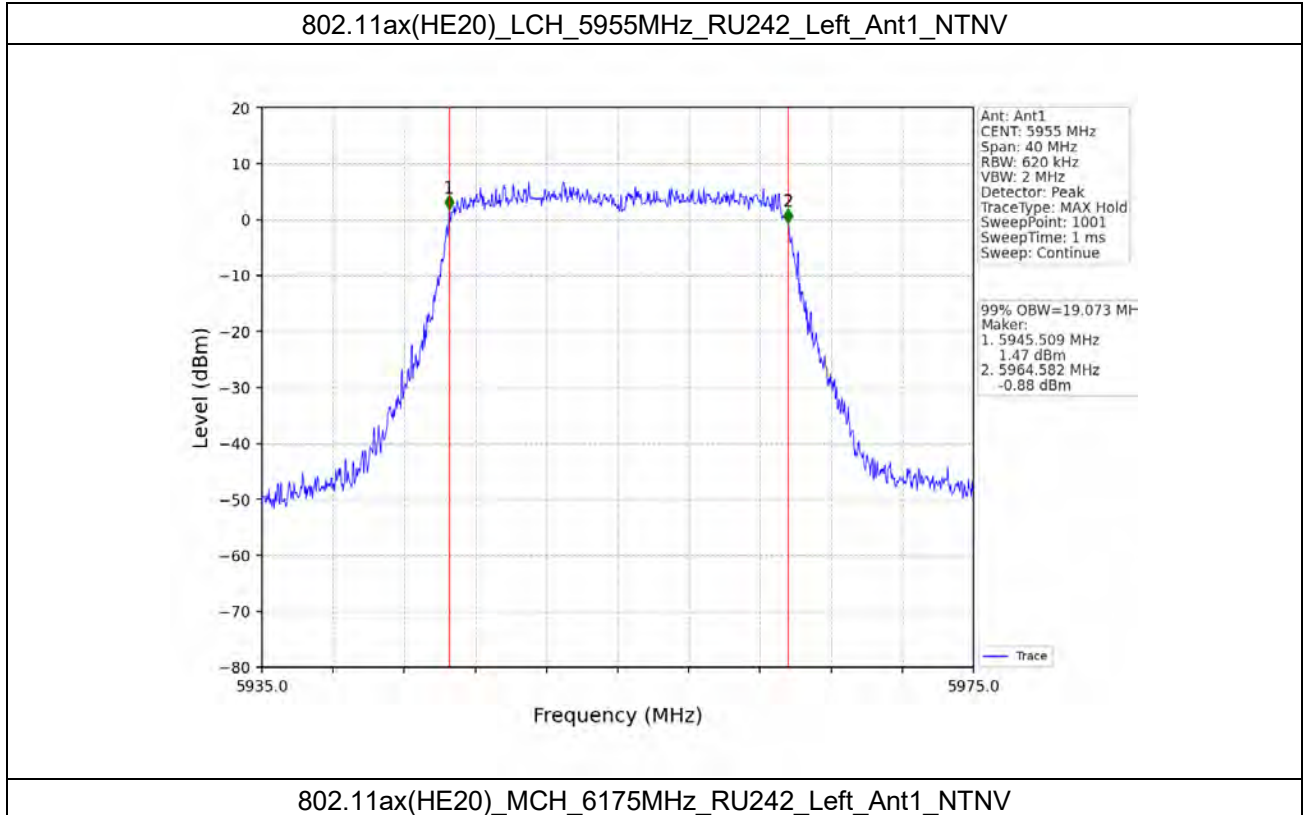

Unless otherwise agreed in writing, this document is issued by the Company subject to its General Conditions of Service printed overleaf, available on request or accessible at <https://www.sgs.com/en/Terms-and-Conditions>. Attention is drawn to the limitation of liability, indemnification and jurisdiction issues defined therein. Any holder of this document is advised that information contained hereon reflects the Company's findings at the time of its intervention only and within the limits of Client's instructions, if any. The Company's sole responsibility is to its Client and this document does not exonerate parties to a transaction from exercising all their rights and obligations under the transaction documents. This document cannot be reproduced except in full, without prior written approval of the Company. Any unauthorized alteration, forgery or falsification of the content or appearance of this document is unlawful and offenders may be prosecuted to the fullest extent of the law. Unless otherwise stated the results shown in this test report refer only to the sample(s) tested and such sample(s) are retained for 30 days only.

Attention: To check the authenticity of testing /inspection report & certificate, please contact us at telephone: (86-755) 8307 1443, or email: CN.Doccheck@sgs.com

SGS-CSTC Standards Technical Services Co., Ltd. Shenzhen Branch Laboratory  
 No.1 Workshop, M-10, Middle Section, Science & Technology Park, Nanshan District, Shenzhen, Guangdong, China 518057 t (86-755) 26012053 f (86-755) 26710594 www.sgsgroup.com.cn  
 中国·广东·深圳市南山区科技园中区M-10栋1号厂房 邮编: 518057 t (86-755) 26012053 f (86-755) 26710594 sgs.china@sgs.com

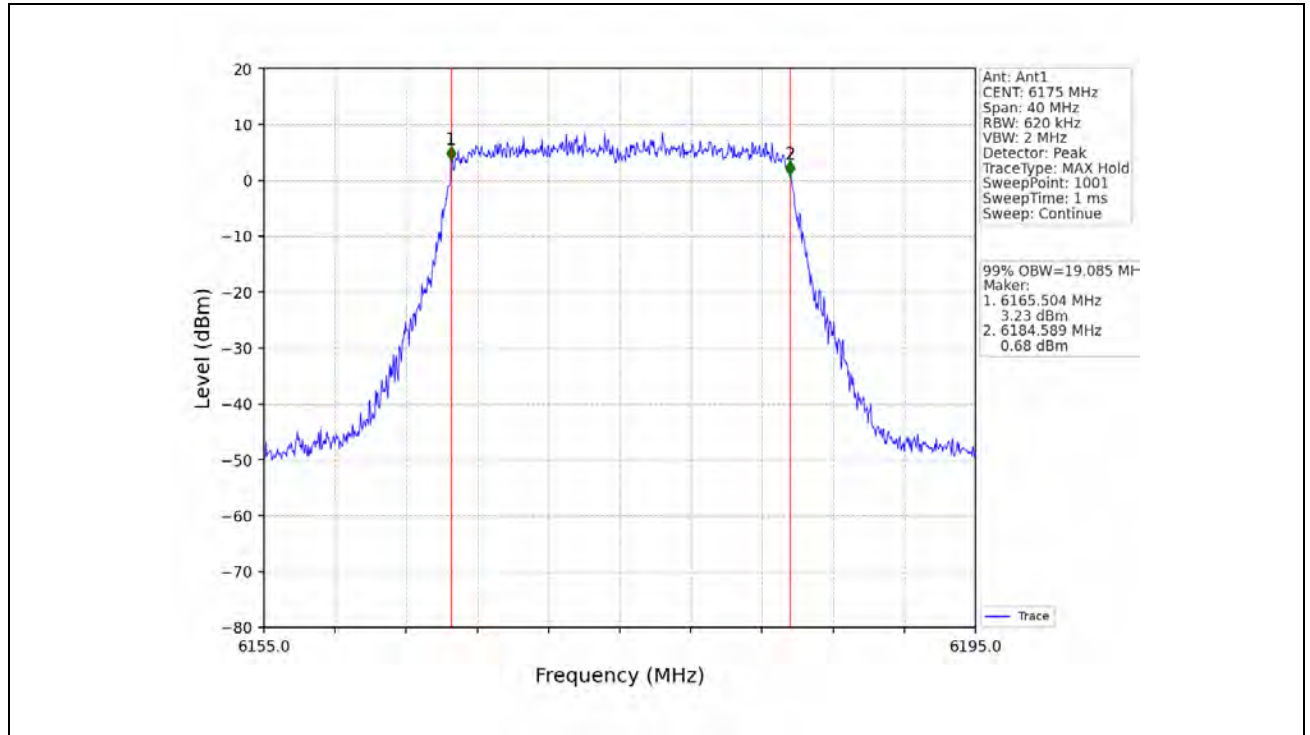

Unless otherwise agreed in writing, this document is issued by the Company subject to its General Conditions of Service printed overleaf, available on request or accessible at <https://www.sgs.com/en/Terms-and-Conditions>. Attention is drawn to the limitation of liability, indemnification and jurisdiction issues defined therein. Any holder of this document is advised that information contained hereon reflects the Company's findings at the time of its intervention only and within the limits of Client's instructions, if any. The Company's sole responsibility is to its Client and this document does not exonerate parties to a transaction from exercising all their rights and obligations under the transaction documents. This document cannot be reproduced except in full, without prior written approval of the Company. Any unauthorized alteration, forgery or falsification of the content or appearance of this document is unlawful and offenders may be prosecuted to the fullest extent of the law. Unless otherwise stated the results shown in this test report refer only to the sample(s) tested and such sample(s) are retained for 30 days only.

Attention: To check the authenticity of testing /inspection report & certificate, please contact us at telephone: (86-755) 8307 1443, or email: CN.Doccheck@sgs.com



802.11ax(HE20)\_HCH\_6415MHz\_RU242\_Left\_Ant1\_NTNV

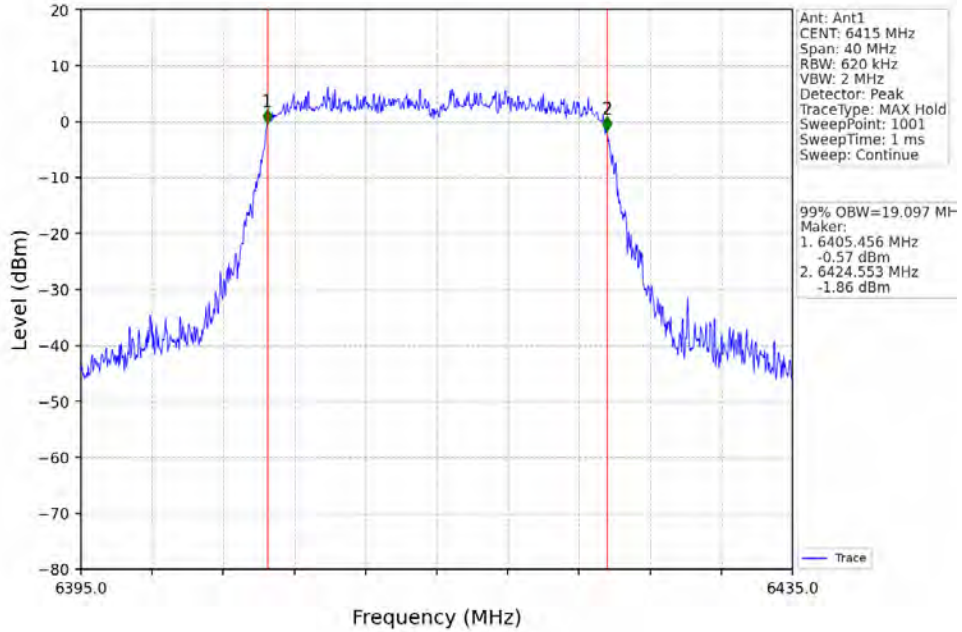

802.11ax(HE40)\_LCH\_5965MHz\_RU484\_Left\_Ant1\_NTNV

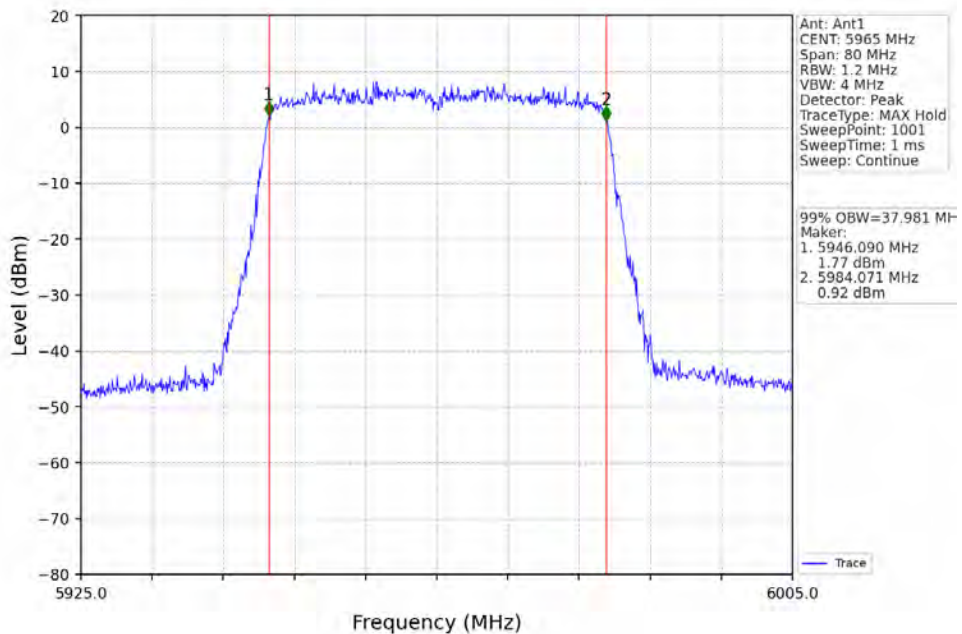

Unless otherwise agreed in writing, this document is issued by the Company subject to its General Conditions of Service printed overleaf, available on request or accessible at <https://www.sgs.com/en/Terms-and-Conditions>. Attention is drawn to the limitation of liability, indemnification and jurisdiction issues defined therein. Any holder of this document is advised that information contained hereon reflects the Company's findings at the time of its intervention only and within the limits of Client's instructions, if any. The Company's sole responsibility is to its Client and this document does not exonerate parties to a transaction from exercising all their rights and obligations under the transaction documents. This document cannot be reproduced except in full, without prior written approval of the Company. Any unauthorized alteration, forgery or falsification of the content or appearance of this document is unlawful and offenders may be prosecuted to the fullest extent of the law. Unless otherwise stated the results shown in this test report refer only to the sample(s) tested and such sample(s) are retained for 30 days only.

Attention: To check the authenticity of testing /inspection report & certificate, please contact us at telephone: (86-755) 8307 1443, or email: CN.Doccheck@sgs.com

802.11ax(HE40)\_MCH\_6165MHz\_RU484\_Left\_Ant1\_NTNV

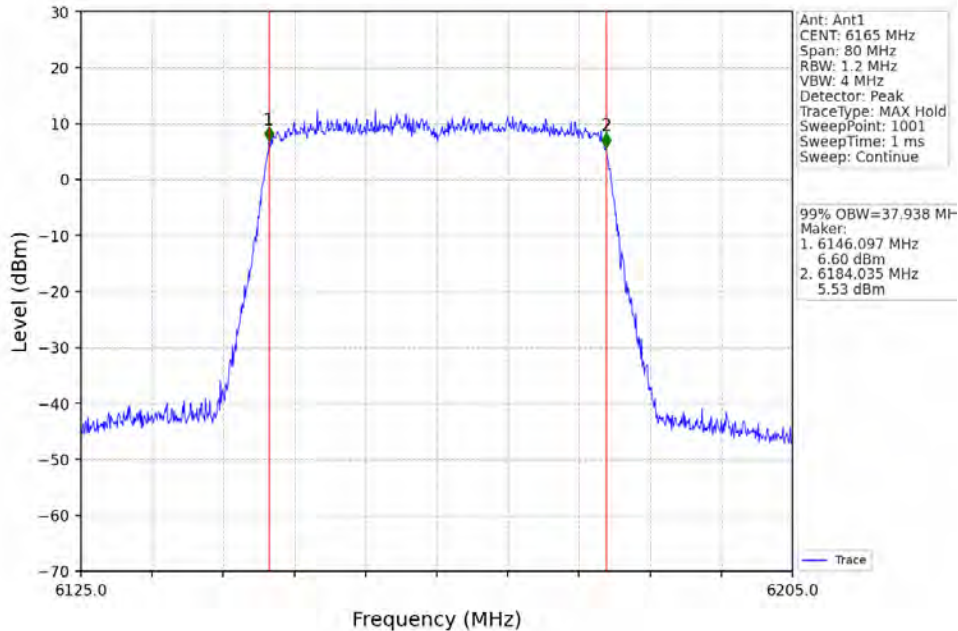

802.11ax(HE40)\_HCH\_6405MHz\_RU484\_Left\_Ant1\_NTNV

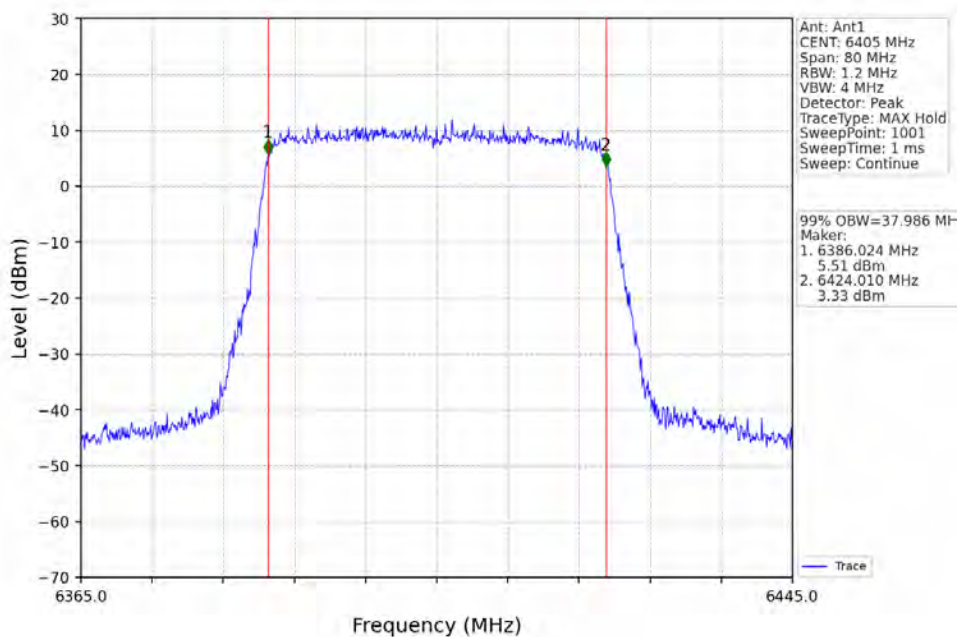

Unless otherwise agreed in writing, this document is issued by the Company subject to its General Conditions of Service printed overleaf, available on request or accessible at <https://www.sgs.com/en/Terms-and-Conditions>. Attention is drawn to the limitation of liability, indemnification and jurisdiction issues defined therein. Any holder of this document is advised that information contained hereon reflects the Company's findings at the time of its intervention only and within the limits of Client's instructions, if any. The Company's sole responsibility is to its Client and this document does not exonerate parties to a transaction from exercising all their rights and obligations under the transaction documents. This document cannot be reproduced except in full, without prior written approval of the Company. Any unauthorized alteration, forgery or falsification of the content or appearance of this document is unlawful and offenders may be prosecuted to the fullest extent of the law. Unless otherwise stated the results shown in this test report refer only to the sample(s) tested and such sample(s) are retained for 30 days only.



802.11ax(HE80)\_LCH\_5985MHz\_RU996\_Left\_Ant1\_NTNV

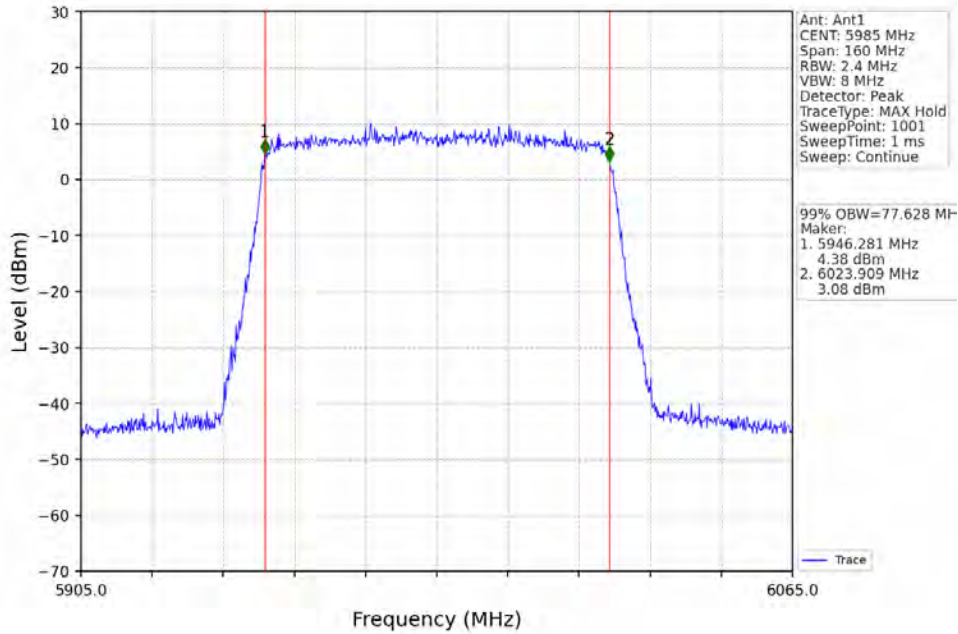

802.11ax(HE80)\_MCH\_6145MHz\_RU996\_Left\_Ant1\_NTNV

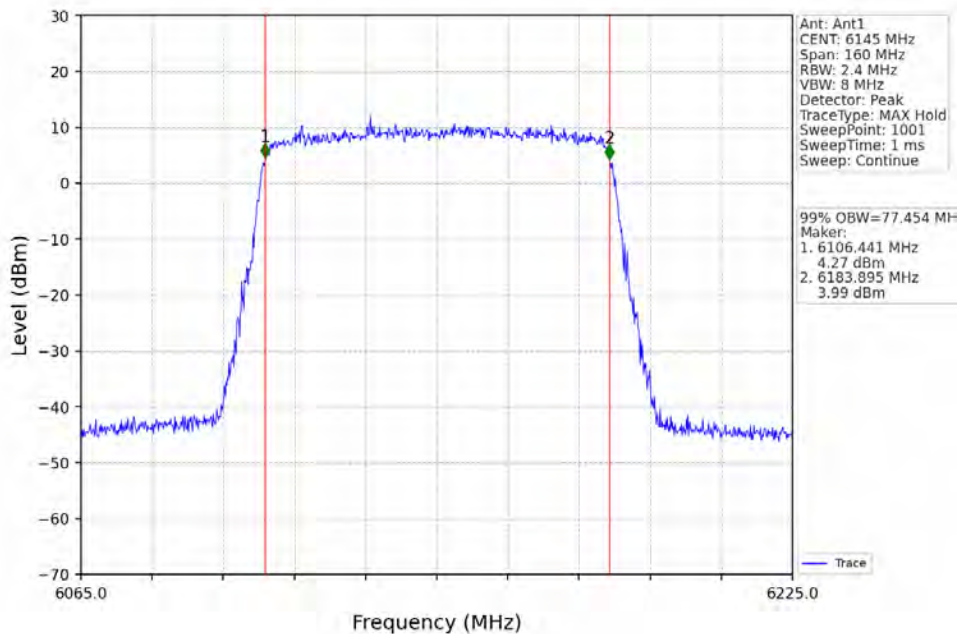

Unless otherwise agreed in writing, this document is issued by the Company subject to its General Conditions of Service printed overleaf, available on request or accessible at <https://www.sgs.com/en/Terms-and-Conditions>. Attention is drawn to the limitation of liability, indemnification and jurisdiction issues defined therein. Any holder of this document is advised that information contained hereon reflects the Company's findings at the time of its intervention only and within the limits of Client's instructions, if any. The Company's sole responsibility is to its Client and this document does not exonerate parties to a transaction from exercising all their rights and obligations under the transaction documents. This document cannot be reproduced except in full, without prior written approval of the Company. Any unauthorized alteration, forgery or falsification of the content or appearance of this document is unlawful and offenders may be prosecuted to the fullest extent of the law. Unless otherwise stated the results shown in this test report refer only to the sample(s) tested and such sample(s) are retained for 30 days only.

802.11ax(HE80)\_HCH\_6385MHz\_RU996\_Left\_Ant1\_NTNV

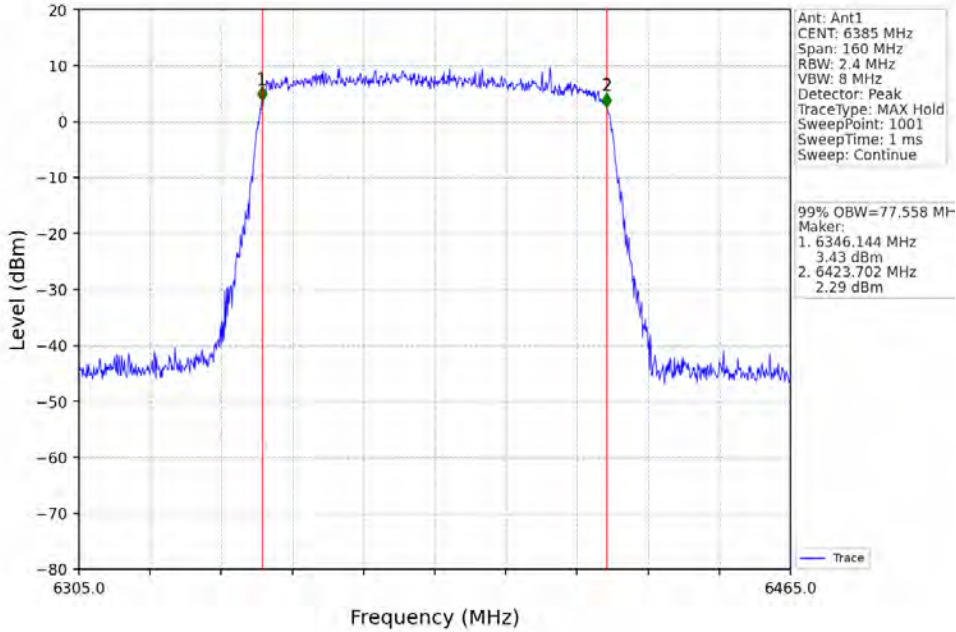

802.11ax(HE160)\_LCH\_6025MHz\_2xRU996\_Left\_Ant1\_NTNV

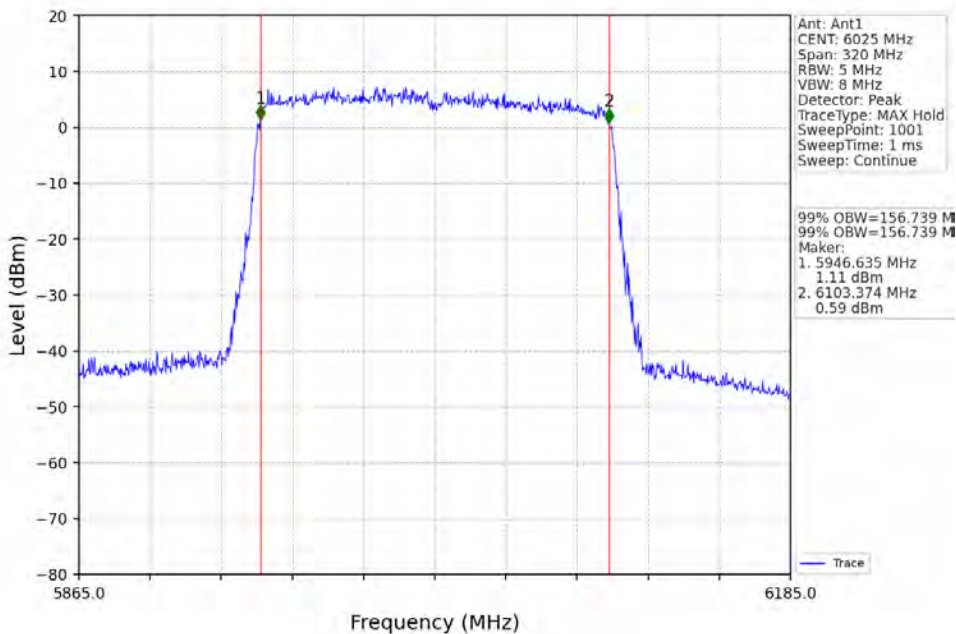

Unless otherwise agreed in writing, this document is issued by the Company subject to its General Conditions of Service printed overleaf, available on request or accessible at <https://www.sgs.com/en/Terms-and-Conditions>. Attention is drawn to the limitation of liability, indemnification and jurisdiction issues defined therein. Any holder of this document is advised that information contained hereon reflects the Company's findings at the time of its intervention only and within the limits of Client's instructions, if any. The Company's sole responsibility is to its Client and this document does not exonerate parties to a transaction from exercising all their rights and obligations under the transaction documents. This document cannot be reproduced except in full, without prior written approval of the Company. Any unauthorized alteration, forgery or falsification of the content or appearance of this document is unlawful and offenders may be prosecuted to the fullest extent of the law. Unless otherwise stated the results shown in this test report refer only to the sample(s) tested and such sample(s) are retained for 30 days only.

Attention: To check the authenticity of testing /inspection report & certificate, please contact us at telephone: (86-755) 8307 1443, or email: CN.Doccheck@sgs.com  
 No.1 Workshop, M-10, Middle Section, Science & Technology Park, Nanshan District, Shenzhen, Guangdong, China 518057 t (86-755) 26012053 f (86-755) 26710594 www.sgs.com.cn  
 中国·广东·深圳市南山区科技园中区M-10栋1号厂房 邮编: 518057 t (86-755) 26012053 f (86-755) 26710594 sgs.china@sgs.com



802.11ax(HE160)\_MCH\_6185MHz\_2xRU996\_Left\_Ant1\_NTNV

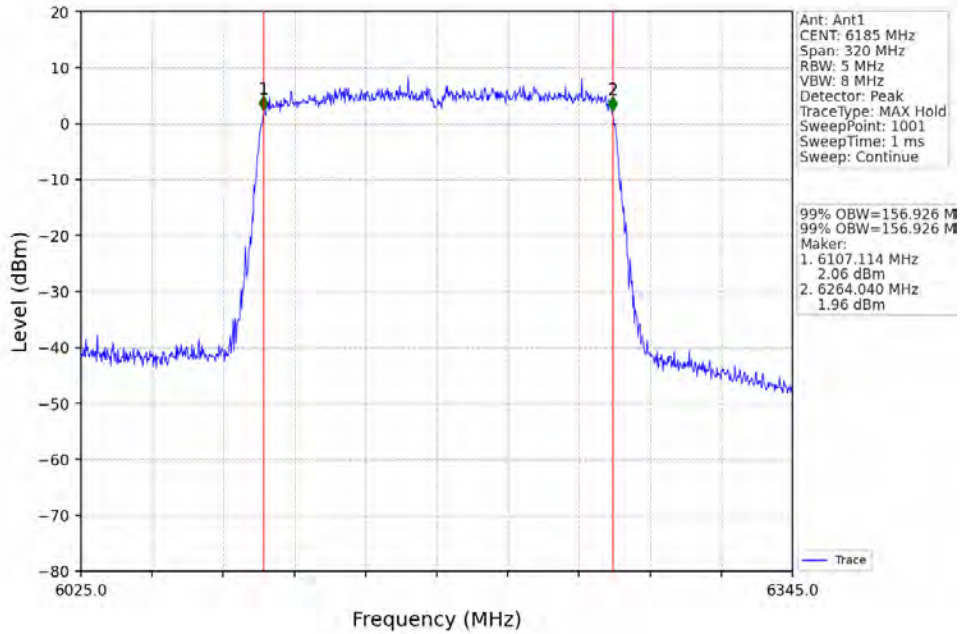

802.11ax(HE160)\_HCH\_6345MHz\_2xRU996\_Left\_Ant1\_NTNV

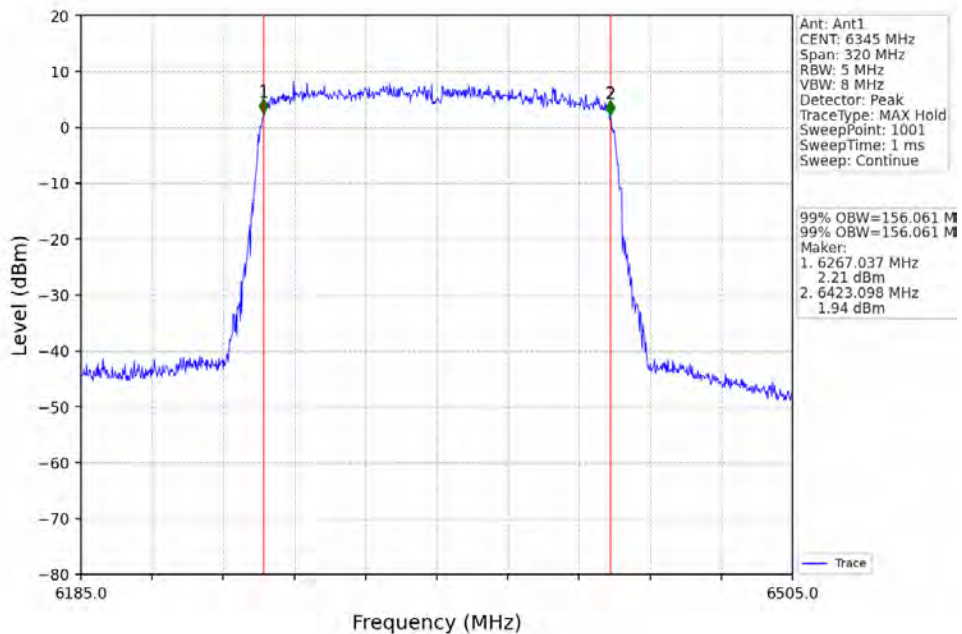

Unless otherwise agreed in writing, this document is issued by the Company subject to its General Conditions of Service printed overleaf, available on request or accessible at <https://www.sgs.com/en/Terms-and-Conditions>. Attention is drawn to the limitation of liability, indemnification and jurisdiction issues defined therein. Any holder of this document is advised that information contained hereon reflects the Company's findings at the time of its intervention only and within the limits of Client's instructions, if any. The Company's sole responsibility is to its Client and this document does not exonerate parties to a transaction from exercising all their rights and obligations under the transaction documents. This document cannot be reproduced except in full, without prior written approval of the Company. Any unauthorized alteration, forgery or falsification of the content or appearance of this document is unlawful and offenders may be prosecuted to the fullest extent of the law. Unless otherwise stated the results shown in this test report refer only to the sample(s) tested and such sample(s) are retained for 30 days only.

2.2 26dB BW

2.2.1 Test Result

ENV	Mode	TX Type	Frequency (MHz)	RU	RU Pos	ANT	26dB Bandwidth (MHz)		Verdict
							Result	Limit	
NTNV	802.11ax (HE20)	MIMO	5955	RU242	Left	1	20.877	For Report Purpose	Pass
			6175	RU242	Left	1	20.918	For Report Purpose	Pass
			6415	RU242	Left	1	20.973	For Report Purpose	Pass
	802.11ax (HE40)	MIMO	5965	RU484	Left	1	40.534	For Report Purpose	Pass
			6165	RU484	Left	1	40.369	For Report Purpose	Pass
			6405	RU484	Left	1	40.528	For Report Purpose	Pass
	802.11ax (HE80)	MIMO	5985	RU996	Left	1	82.849	For Report Purpose	Pass
			6145	RU996	Left	1	82.137	For Report Purpose	Pass
			6385	RU996	Left	1	82.183	For Report Purpose	Pass
	802.11ax (HE160)	MIMO	6025	2xRU996	Left	1	164.332	For Report Purpose	Pass
			6185	2xRU996	Left	1	165.460	For Report Purpose	Pass
			6345	2xRU996	Left	1	164.457	For Report Purpose	Pass



Unless otherwise agreed in writing, this document is issued by the Company subject to its General Conditions of Service printed overleaf, available on request or accessible at <https://www.sgs.com/en/Terms-and-Conditions>. Attention is drawn to the limitation of liability, indemnification and jurisdiction issues defined therein. Any holder of this document is advised that information contained hereon reflects the Company's findings at the time of its intervention only and within the limits of Client's instructions, if any. The Company's sole responsibility is to its Client and this document does not exonerate parties to a transaction from exercising all their rights and obligations under the transaction documents. This document cannot be reproduced except in full, without prior written approval of the Company. Any unauthorized alteration, forgery or falsification of the content or appearance of this document is unlawful and offenders may be prosecuted to the fullest extent of the law. Unless otherwise stated the results shown in this test report refer only to the sample(s) tested and such sample(s) are retained for 30 days only.

Attention: To check the authenticity of testing /inspection report & certificate, please contact us at telephone: (86-755) 8307 1443, or email: CN.Doccheck@sgs.com

### 2.2.2 Test Graph

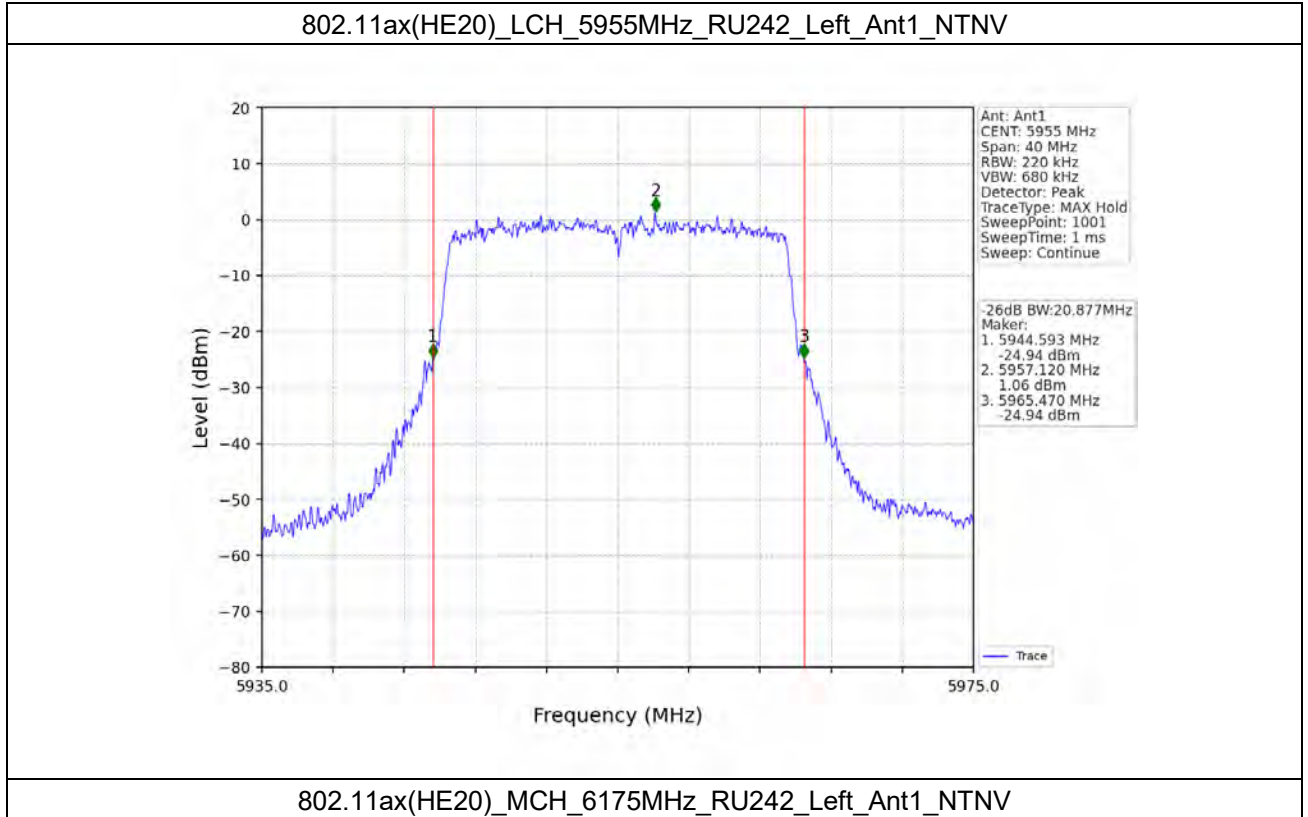

Unless otherwise agreed in writing, this document is issued by the Company subject to its General Conditions of Service printed overleaf, available on request or accessible at <https://www.sgs.com/en/Terms-and-Conditions>. Attention is drawn to the limitation of liability, indemnification and jurisdiction issues defined therein. Any holder of this document is advised that information contained hereon reflects the Company's findings at the time of its intervention only and within the limits of Client's instructions, if any. The Company's sole responsibility is to its Client and this document does not exonerate parties to a transaction from exercising all their rights and obligations under the transaction documents. This document cannot be reproduced except in full, without prior written approval of the Company. Any unauthorized alteration, forgery or falsification of the content or appearance of this document is unlawful and offenders may be prosecuted to the fullest extent of the law. Unless otherwise stated the results shown in this test report refer only to the sample(s) tested and such sample(s) are retained for 30 days only.

Attention: To check the authenticity of testing /inspection report & certificate, please contact us at telephone: (86-755) 8307 1443, or email: CN.Doccheck@sgs.com

SGS-CSTC Standards Technical Services Co., Ltd. Shenzhen Branch Laboratory  
 No.1 Workshop, M-10, Middle Section, Science & Technology Park, Nanshan District, Shenzhen, Guangdong, China 518057 t (86-755) 26012053 f (86-755) 26710594 www.sgs.com.cn  
 中国·广东·深圳市南山区科技园中区M-10栋1号厂房 邮编: 518057 t (86-755) 26012053 f (86-755) 26710594 sgs.china@sgs.com



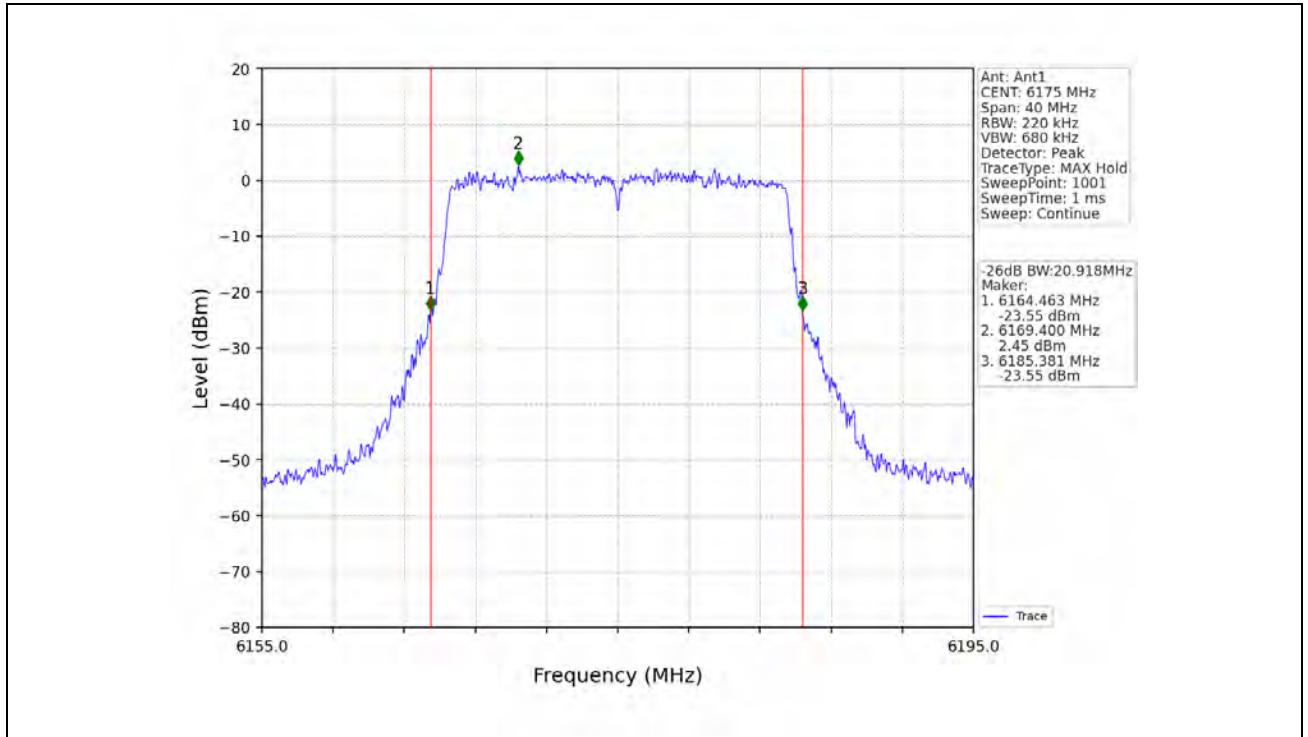

Unless otherwise agreed in writing, this document is issued by the Company subject to its General Conditions of Service printed overleaf, available on request or accessible at <https://www.sgs.com/en/Terms-and-Conditions>. Attention is drawn to the limitation of liability, indemnification and jurisdiction issues defined therein. Any holder of this document is advised that information contained hereon reflects the Company's findings at the time of its intervention only and within the limits of Client's instructions, if any. The Company's sole responsibility is to its Client and this document does not exonerate parties to a transaction from exercising all their rights and obligations under the transaction documents. This document cannot be reproduced except in full, without prior written approval of the Company. Any unauthorized alteration, forgery or falsification of the content or appearance of this document is unlawful and offenders may be prosecuted to the fullest extent of the law. Unless otherwise stated the results shown in this test report refer only to the sample(s) tested and such sample(s) are retained for 30 days only.

Attention: To check the authenticity of testing /inspection report & certificate, please contact us at telephone: (86-755) 8307 1443, or email: [CN.Doccheck@sgs.com](mailto:CN.Doccheck@sgs.com)  
 No.1 Workshop, M-10, Middle Section, Science & Technology Park, Nanshan District, Shenzhen, Guangdong, China 518057 t (86-755) 26012053 f (86-755) 26710594 www.sgs.com.cn  
 中国·广东·深圳市南山区科技园中区M-10栋1号厂房 邮编: 518057 t (86-755) 26012053 f (86-755) 26710594 sgs.china@sgs.com



### 802.11ax(HE20)\_HCH\_6415MHz\_RU242\_Left\_Ant1\_NTNV

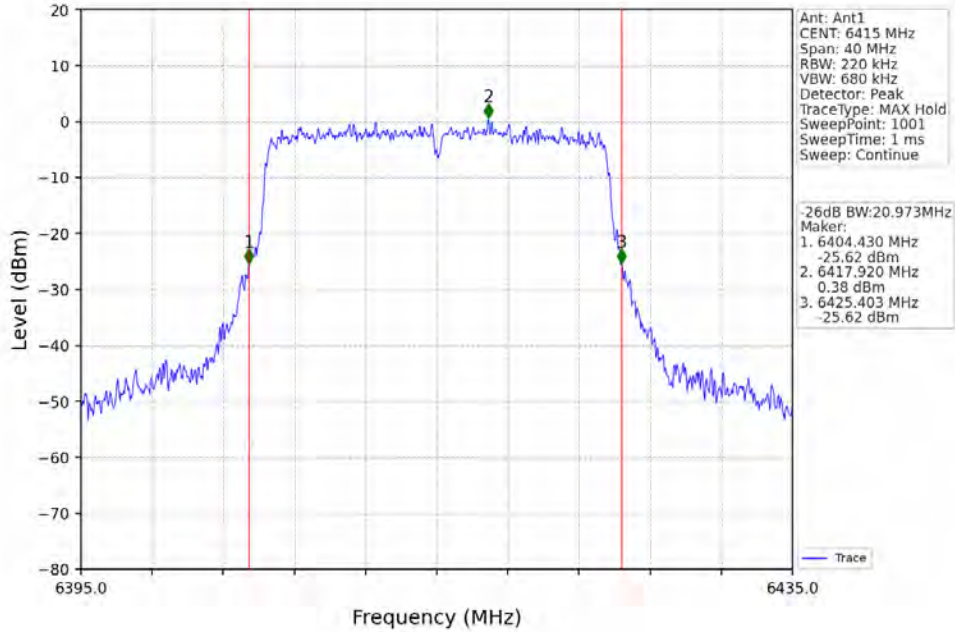

### 802.11ax(HE40)\_LCH\_5965MHz\_RU484\_Left\_Ant1\_NTNV

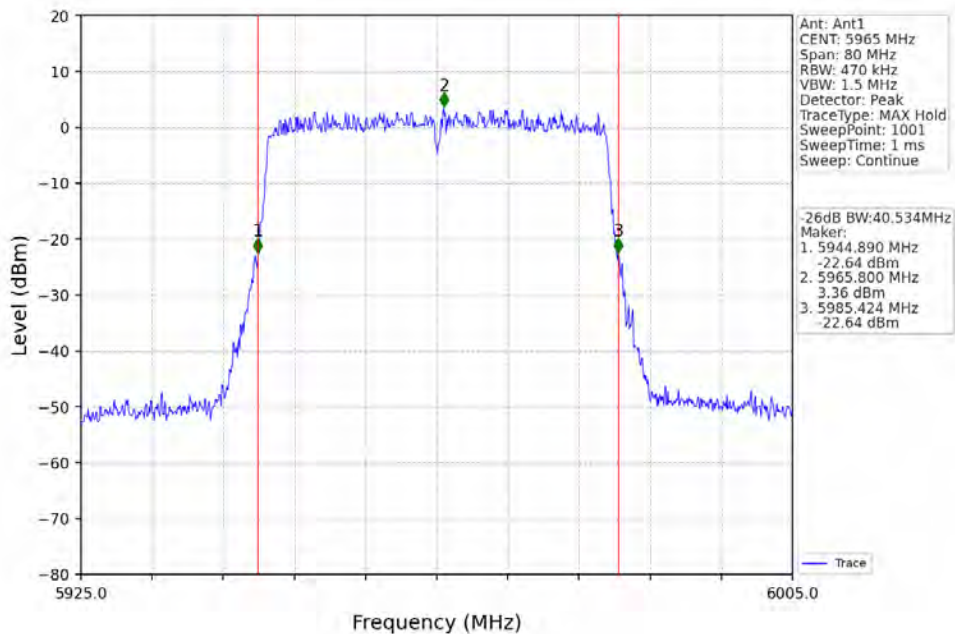

Unless otherwise agreed in writing, this document is issued by the Company subject to its General Conditions of Service printed overleaf, available on request or accessible at <https://www.sgs.com/en/Terms-and-Conditions>. Attention is drawn to the limitation of liability, indemnification and jurisdiction issues defined therein. Any holder of this document is advised that information contained hereon reflects the Company's findings at the time of its intervention only and within the limits of Client's instructions, if any. The Company's sole responsibility is to its Client and this document does not exonerate parties to a transaction from exercising all their rights and obligations under the transaction documents. This document cannot be reproduced except in full, without prior written approval of the Company. Any unauthorized alteration, forgery or falsification of the content or appearance of this document is unlawful and offenders may be prosecuted to the fullest extent of the law. Unless otherwise stated the results shown in this test report refer only to the sample(s) tested and such sample(s) are retained for 30 days only.

Attention: To check the authenticity of testing /inspection report & certificate, please contact us at telephone: (86-755) 8307 1443, or email: CN.Doccheck@sgs.com

802.11ax(HE40)\_MCH\_6165MHz\_RU484\_Left\_Ant1\_NTNV

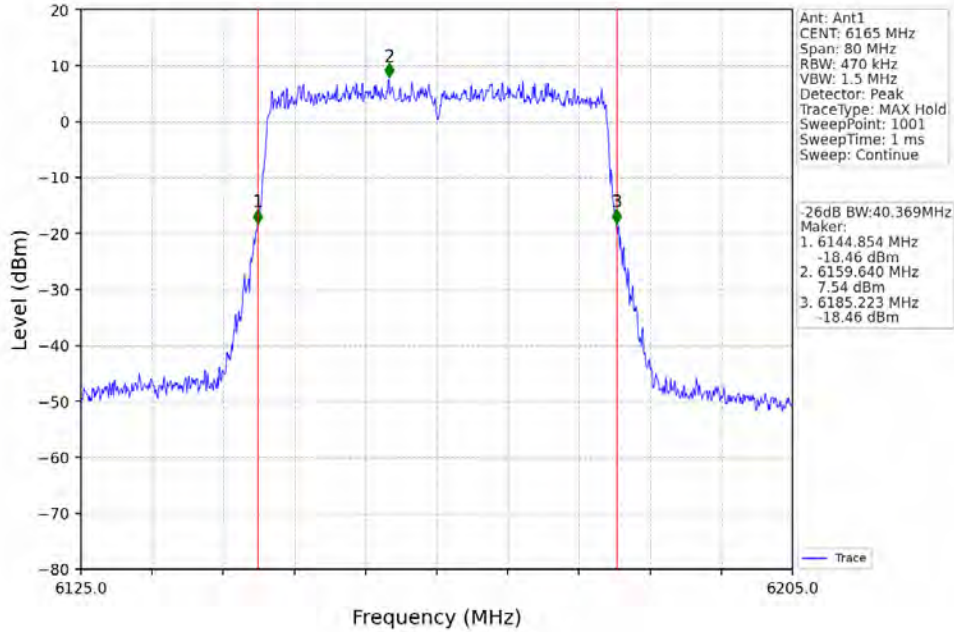

802.11ax(HE40)\_HCH\_6405MHz\_RU484\_Left\_Ant1\_NTNV

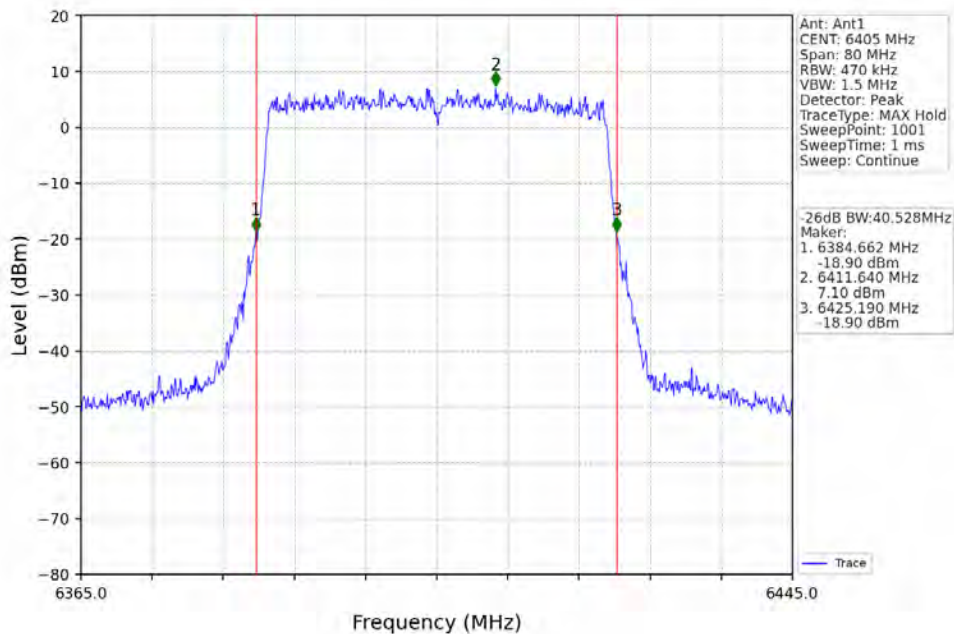

Unless otherwise agreed in writing, this document is issued by the Company subject to its General Conditions of Service printed overleaf, available on request or accessible at <https://www.sgs.com/en/Terms-and-Conditions>. Attention is drawn to the limitation of liability, indemnification and jurisdiction issues defined therein. Any holder of this document is advised that information contained hereon reflects the Company's findings at the time of its intervention only and within the limits of Client's instructions, if any. The Company's sole responsibility is to its Client and this document does not exonerate parties to a transaction from exercising all their rights and obligations under the transaction documents. This document cannot be reproduced except in full, without prior written approval of the Company. Any unauthorized alteration, forgery or falsification of the content or appearance of this document is unlawful and offenders may be prosecuted to the fullest extent of the law. Unless otherwise stated the results shown in this test report refer only to the sample(s) tested and such sample(s) are retained for 30 days only.

Attention: To check the authenticity of testing /inspection report & certificate, please contact us at telephone: (86-755) 8307 1443, or email: CN.Doccheck@sgs.com



802.11ax(HE80)\_LCH\_5985MHz\_RU996\_Left\_Ant1\_NTNV

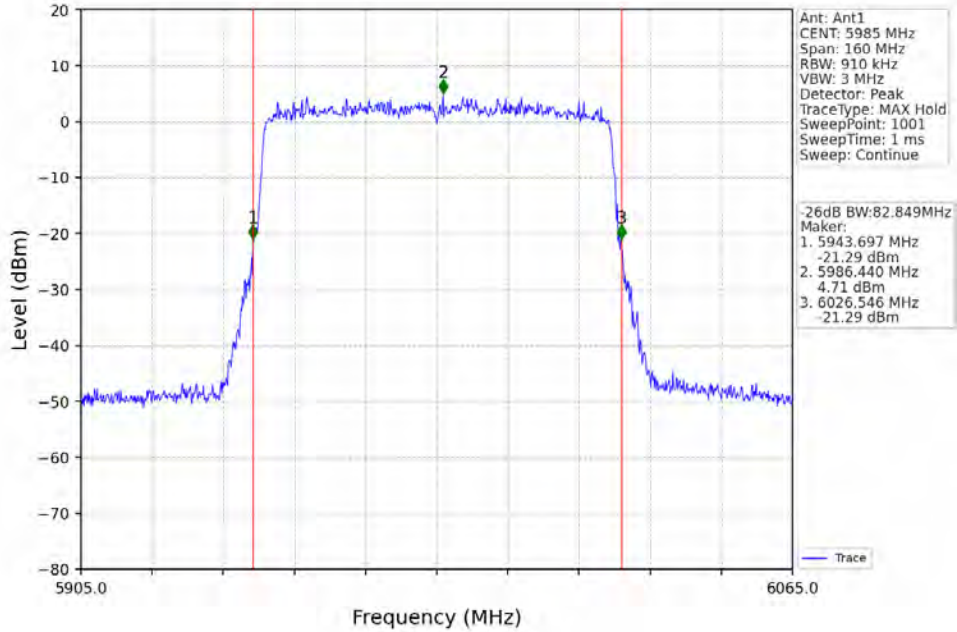

802.11ax(HE80)\_MCH\_6145MHz\_RU996\_Left\_Ant1\_NTNV

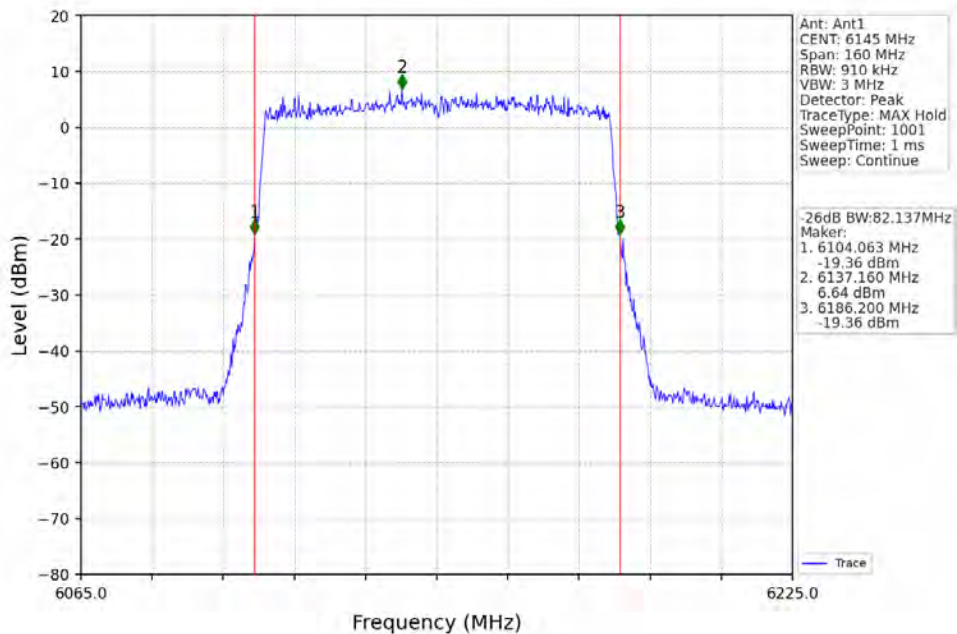

Unless otherwise agreed in writing, this document is issued by the Company subject to its General Conditions of Service printed overleaf, available on request or accessible at <https://www.sgs.com/en/Terms-and-Conditions>. Attention is drawn to the limitation of liability, indemnification and jurisdiction issues defined therein. Any holder of this document is advised that information contained hereon reflects the Company's findings at the time of its intervention only and within the limits of Client's instructions, if any. The Company's sole responsibility is to its Client and this document does not exonerate parties to a transaction from exercising all their rights and obligations under the transaction documents. This document cannot be reproduced except in full, without prior written approval of the Company. Any unauthorized alteration, forgery or falsification of the content or appearance of this document is unlawful and offenders may be prosecuted to the fullest extent of the law. Unless otherwise stated the results shown in this test report refer only to the sample(s) tested and such sample(s) are retained for 30 days only.

Attention: To check the authenticity of testing /inspection report & certificate, please contact us at telephone: (86-755) 8307 1443, or email: CN.Doccheck@sgs.com

802.11ax(HE80)\_HCH\_6385MHz\_RU996\_Left\_Ant1\_NTNV

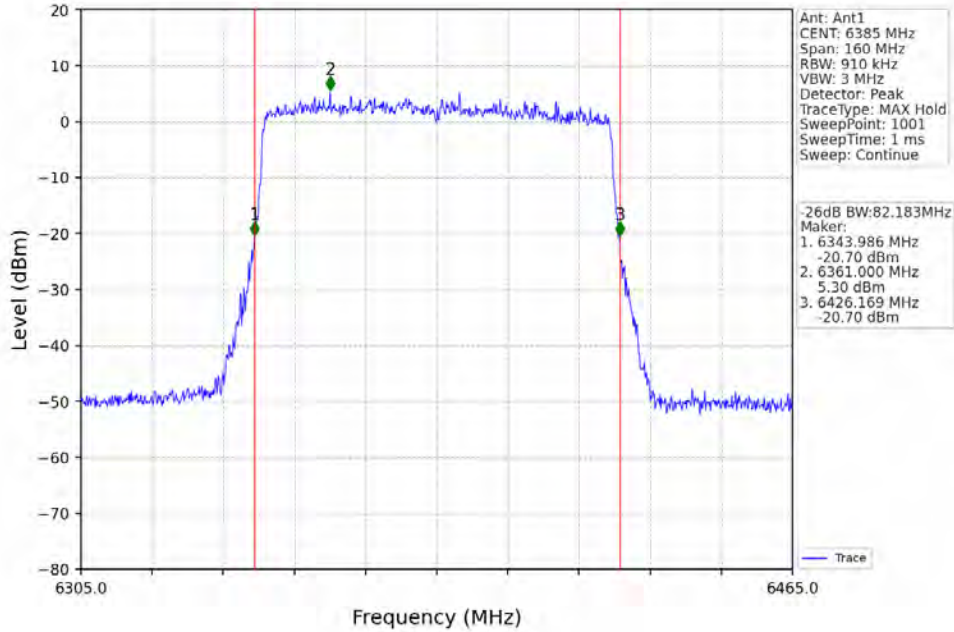

802.11ax(HE160)\_LCH\_6025MHz\_2xRU996\_Left\_Ant1\_NTNV

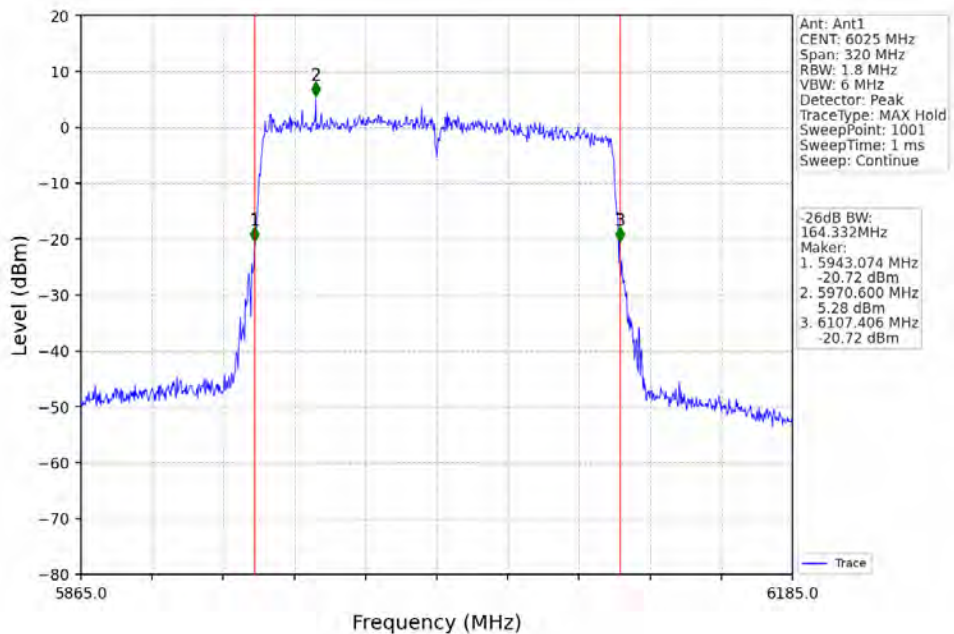

Unless otherwise agreed in writing, this document is issued by the Company subject to its General Conditions of Service printed overleaf, available on request or accessible at <https://www.sgs.com/en/Terms-and-Conditions>. Attention is drawn to the limitation of liability, indemnification and jurisdiction issues defined therein. Any holder of this document is advised that information contained hereon reflects the Company's findings at the time of its intervention only and within the limits of Client's instructions, if any. The Company's sole responsibility is to its Client and this document does not exonerate parties to a transaction from exercising all their rights and obligations under the transaction documents. This document cannot be reproduced except in full, without prior written approval of the Company. Any unauthorized alteration, forgery or falsification of the content or appearance of this document is unlawful and offenders may be prosecuted to the fullest extent of the law. Unless otherwise stated the results shown in this test report refer only to the sample(s) tested and such sample(s) are retained for 30 days only.



802.11ax(HE160)\_MCH\_6185MHz\_2xRU996\_Left\_Ant1\_NTNV

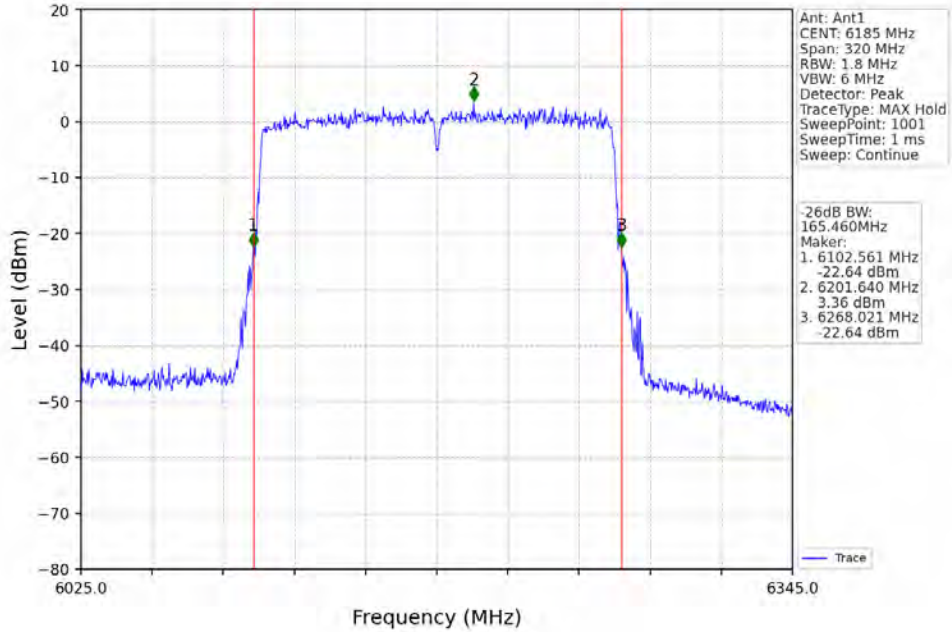

802.11ax(HE160)\_HCH\_6345MHz\_2xRU996\_Left\_Ant1\_NTNV

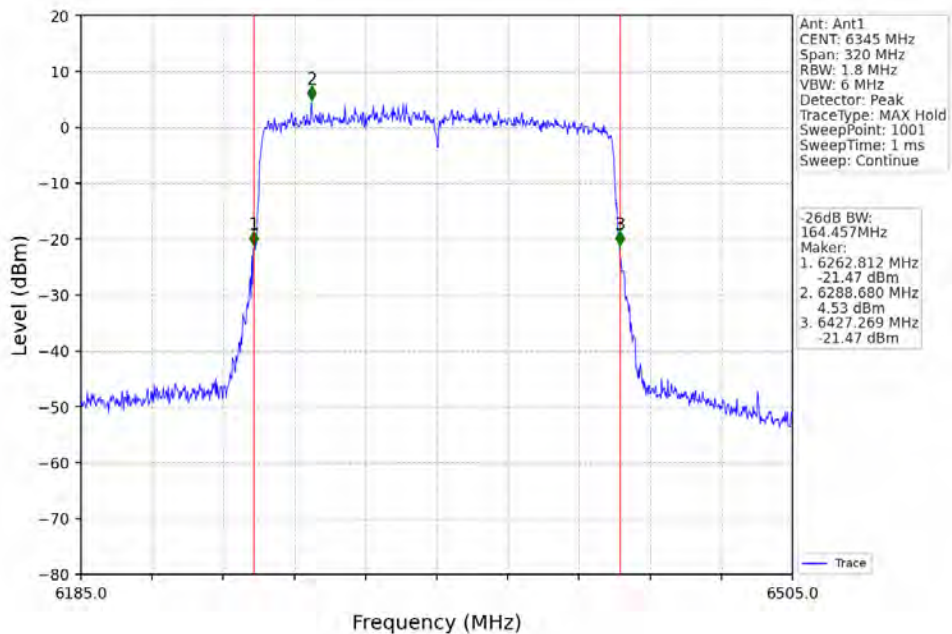

Unless otherwise agreed in writing, this document is issued by the Company subject to its General Conditions of Service printed overleaf, available on request or accessible at <https://www.sgs.com/en/Terms-and-Conditions>. Attention is drawn to the limitation of liability, indemnification and jurisdiction issues defined therein. Any holder of this document is advised that information contained hereon reflects the Company's findings at the time of its intervention only and within the limits of Client's instructions, if any. The Company's sole responsibility is to its Client and this document does not exonerate parties to a transaction from exercising all their rights and obligations under the transaction documents. This document cannot be reproduced except in full, without prior written approval of the Company. Any unauthorized alteration, forgery or falsification of the content or appearance of this document is unlawful and offenders may be prosecuted to the fullest extent of the law. Unless otherwise stated the results shown in this test report refer only to the sample(s) tested and such sample(s) are retained for 30 days only.

2.3 OBW

2.3.1 Test Result

ENV	Mode	TX Type	Frequency (MHz)	RU	RU Pos	ANT	99% Occupied Bandwidth (MHz)		Verdict
							Result	Limit	
NTNV	802.11ax (HE20)	MIMO	6435	RU242	Left	1	19.099	<=160	Pass
			6475	RU242	Left	1	19.068	<=160	Pass
			6515	RU242	Left	1	19.047	<=160	Pass
	802.11ax (HE40)	MIMO	6445	RU484	Left	1	38.022	<=160	Pass
			6485	RU484	Left	1	37.985	<=160	Pass
	802.11ax (HE80)	MIMO	6465	RU996	Left	1	77.699	<=160	Pass



Unless otherwise agreed in writing, this document is issued by the Company subject to its General Conditions of Service printed overleaf, available on request or accessible at <https://www.sgs.com/en/Terms-and-Conditions>. Attention is drawn to the limitation of liability, indemnification and jurisdiction issues defined therein. Any holder of this document is advised that information contained hereon reflects the Company's findings at the time of its intervention only and within the limits of Client's instructions, if any. The Company's sole responsibility is to its Client and this document does not exonerate parties to a transaction from exercising all their rights and obligations under the transaction documents. This document cannot be reproduced except in full, without prior written approval of the Company. Any unauthorized alteration, forgery or falsification of the content or appearance of this document is unlawful and offenders may be prosecuted to the fullest extent of the law. Unless otherwise stated the results shown in this test report refer only to the sample(s) tested and such sample(s) are retained for 30 days only.

Attention: To check the authenticity of testing /inspection report & certificate, please contact us at telephone: (86-755) 8307 1443, or email: CN.Doccheck@sgs.com  
 No.1 Workshop, M-10, Middle Section, Science & Technology Park, Nanshan District, Shenzhen, Guangdong, China 518057 t (86-755) 26012053 f (86-755) 26710594 www.sgs.com.cn  
 中国·广东·深圳市南山区科技园中区M-10栋1号厂房 邮编: 518057 t (86-755) 26012053 f (86-755) 26710594 sgs.china@sgs.com

2.3.2 Test Graph

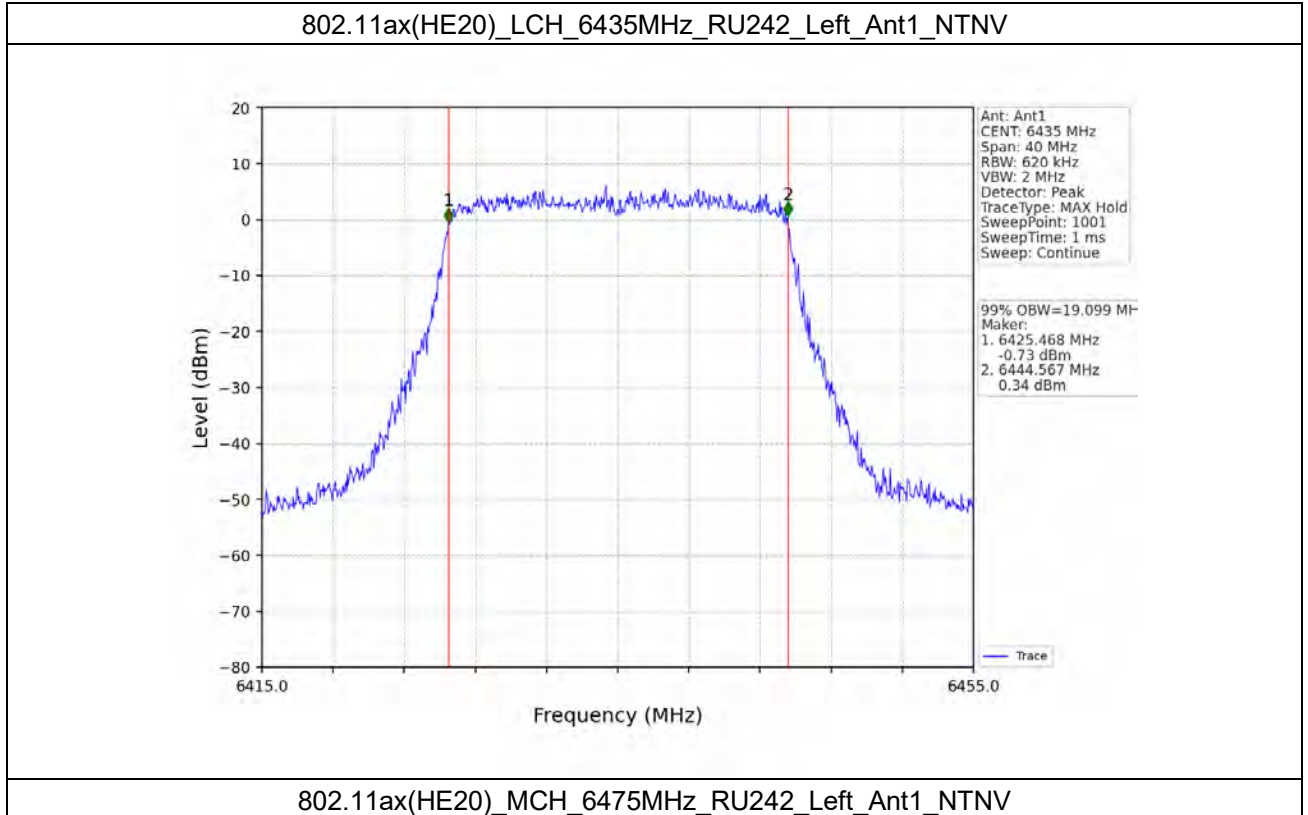

Unless otherwise agreed in writing, this document is issued by the Company subject to its General Conditions of Service printed overleaf, available on request or accessible at <https://www.sgs.com/en/Terms-and-Conditions>. Attention is drawn to the limitation of liability, indemnification and jurisdiction issues defined therein. Any holder of this document is advised that information contained hereon reflects the Company's findings at the time of its intervention only and within the limits of Client's instructions, if any. The Company's sole responsibility is to its Client and this document does not exonerate parties to a transaction from exercising all their rights and obligations under the transaction documents. This document cannot be reproduced except in full, without prior written approval of the Company. Any unauthorized alteration, forgery or falsification of the content or appearance of this document is unlawful and offenders may be prosecuted to the fullest extent of the law. Unless otherwise stated the results shown in this test report refer only to the sample(s) tested and such sample(s) are retained for 30 days only.

Attention: To check the authenticity of testing /inspection report & certificate, please contact us at telephone: (86-755) 8307 1443, or email: CN.Doccheck@sgs.com

No.1 Workshop, M-10, Middle Section, Science & Technology Park, Nanshan District, Shenzhen, Guangdong, China 518057 t (86-755) 26012053 f (86-755) 26710594 www.sgsgroup.com.cn  
 中国·广东·深圳市南山区科技园中区M-10栋1号厂房 邮编: 518057 t (86-755) 26012053 f (86-755) 26710594 sgs.china@sgs.com



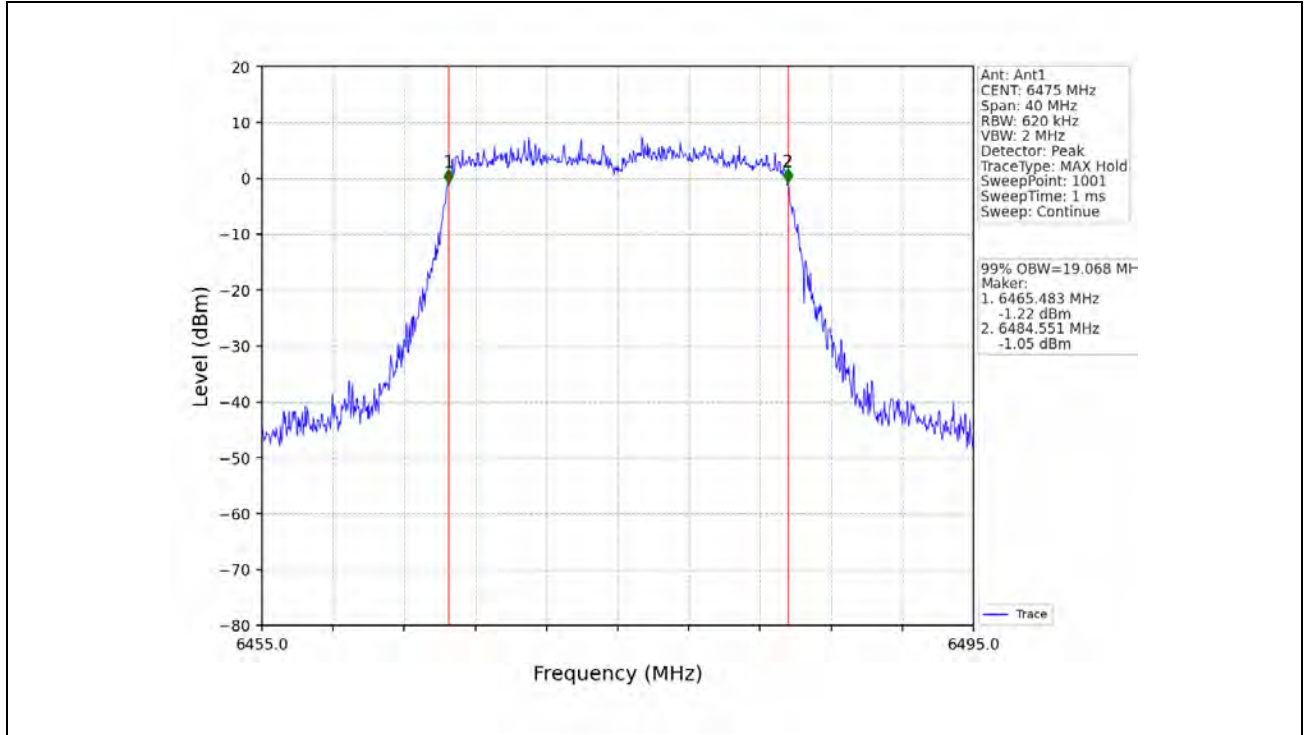

Unless otherwise agreed in writing, this document is issued by the Company subject to its General Conditions of Service printed overleaf, available on request or accessible at <https://www.sgs.com/en/Terms-and-Conditions>. Attention is drawn to the limitation of liability, indemnification and jurisdiction issues defined therein. Any holder of this document is advised that information contained hereon reflects the Company's findings at the time of its intervention only and within the limits of Client's instructions, if any. The Company's sole responsibility is to its Client and this document does not exonerate parties to a transaction from exercising all their rights and obligations under the transaction documents. This document cannot be reproduced except in full, without prior written approval of the Company. Any unauthorized alteration, forgery or falsification of the content or appearance of this document is unlawful and offenders may be prosecuted to the fullest extent of the law. Unless otherwise stated the results shown in this test report refer only to the sample(s) tested and such sample(s) are retained for 30 days only.

Attention: To check the authenticity of testing /inspection report & certificate, please contact us at telephone: (86-755) 8307 1443, or email: [CN.Doccheck@sgs.com](mailto:CN.Doccheck@sgs.com)  
 No.1 Workshop, M-10, Middle Section, Science & Technology Park, Nanshan District, Shenzhen, Guangdong, China 518057 t (86-755) 26012053 f (86-755) 26710594 www.sgs.com.cn  
 中国·广东·深圳市南山区科技园中区M-10栋1号厂房 邮编: 518057 t (86-755) 26012053 f (86-755) 26710594 sgs.china@sgs.com



802.11ax(HE20)\_HCH\_6515MHz\_RU242\_Left\_Ant1\_NTNV

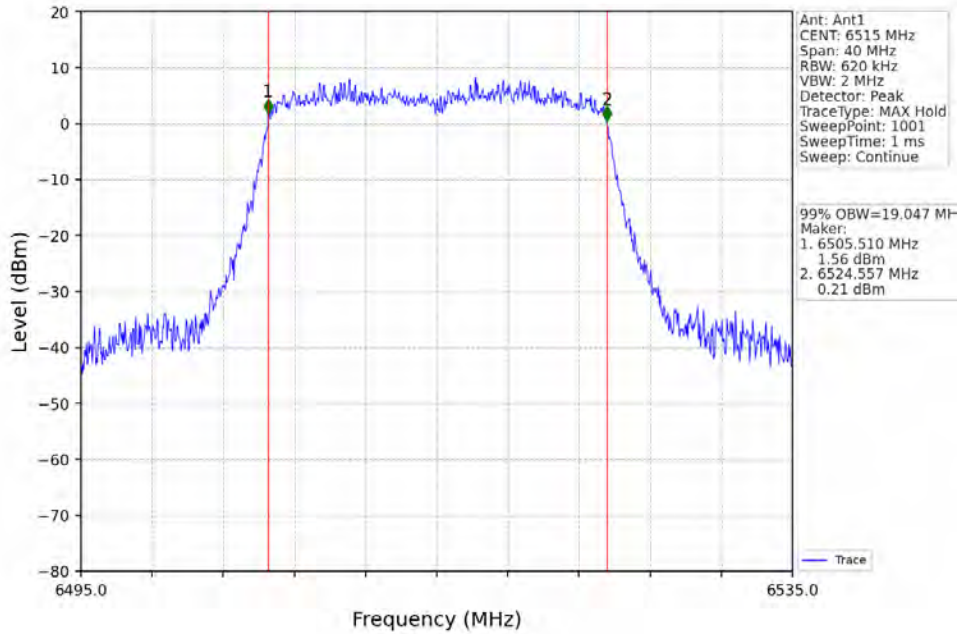

802.11ax(HE40)\_LCH\_6445MHz\_RU484\_Left\_Ant1\_NTNV

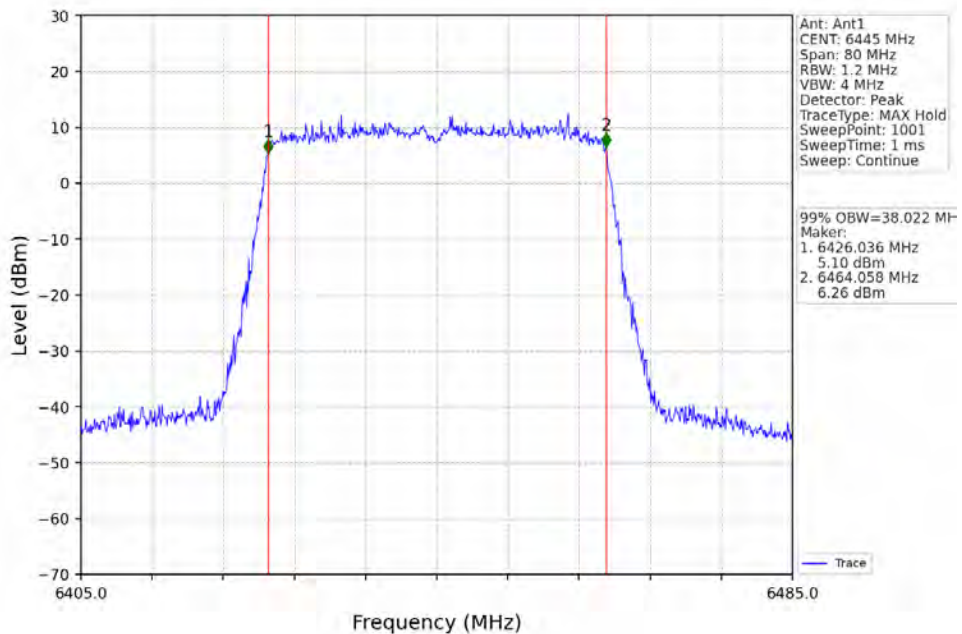

Unless otherwise agreed in writing, this document is issued by the Company subject to its General Conditions of Service printed overleaf, available on request or accessible at <https://www.sgs.com/en/Terms-and-Conditions>. Attention is drawn to the limitation of liability, indemnification and jurisdiction issues defined therein. Any holder of this document is advised that information contained hereon reflects the Company's findings at the time of its intervention only and within the limits of Client's instructions, if any. The Company's sole responsibility is to its Client and this document does not exonerate parties to a transaction from exercising all their rights and obligations under the transaction documents. This document cannot be reproduced except in full, without prior written approval of the Company. Any unauthorized alteration, forgery or falsification of the content or appearance of this document is unlawful and offenders may be prosecuted to the fullest extent of the law. Unless otherwise stated the results shown in this test report refer only to the sample(s) tested and such sample(s) are retained for 30 days only.

Attention: To check the authenticity of testing /inspection report & certificate, please contact us at telephone: (86-755) 8307 1443, or email: CN.Doccheck@sgs.com

### 802.11ax(HE40)\_MCH\_6485MHz\_RU484\_Left\_Ant1\_NTNV

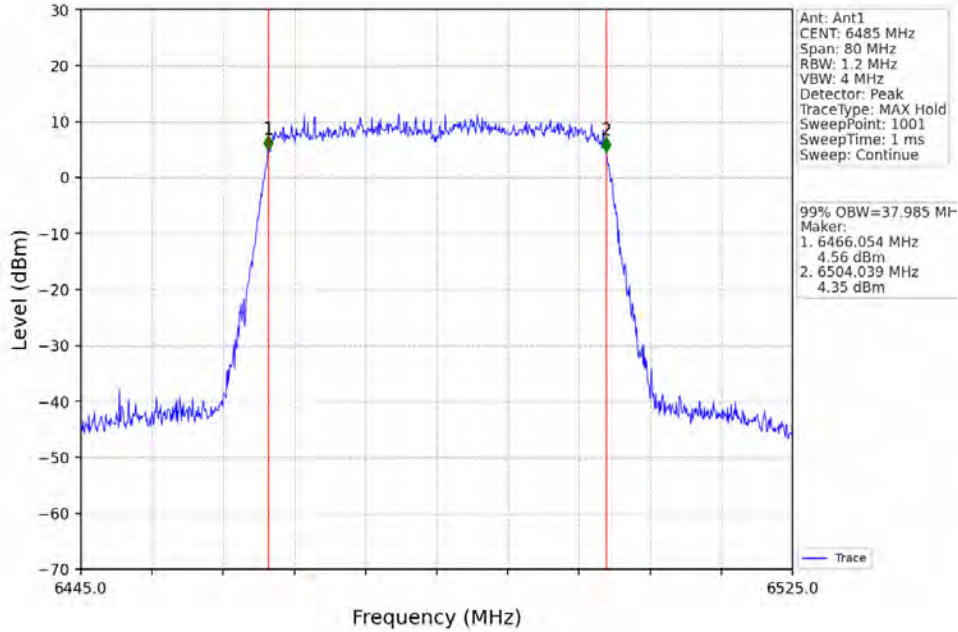

### 802.11ax(HE80)\_LCH\_6465MHz\_RU996\_Left\_Ant1\_NTNV

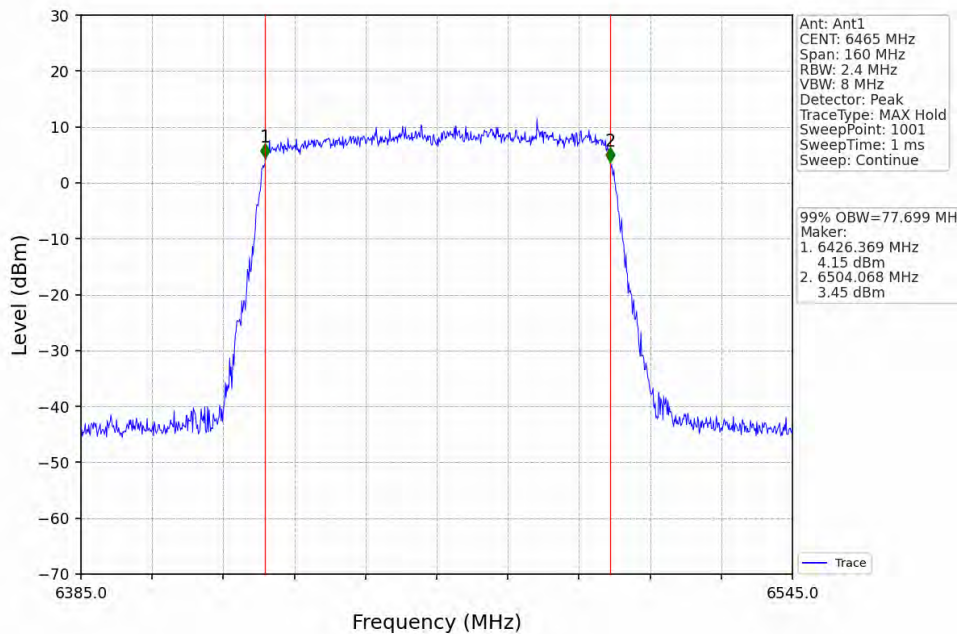

Unless otherwise agreed in writing, this document is issued by the Company subject to its General Conditions of Service printed overleaf, available on request or accessible at <https://www.sgs.com/en/Terms-and-Conditions>. Attention is drawn to the limitation of liability, indemnification and jurisdiction issues defined therein. Any holder of this document is advised that information contained hereon reflects the Company's findings at the time of its intervention only and within the limits of Client's instructions, if any. The Company's sole responsibility is to its Client and this document does not exonerate parties to a transaction from exercising all their rights and obligations under the transaction documents. This document cannot be reproduced except in full, without prior written approval of the Company. Any unauthorized alteration, forgery or falsification of the content or appearance of this document is unlawful and offenders may be prosecuted to the fullest extent of the law. Unless otherwise stated the results shown in this test report refer only to the sample(s) tested and such sample(s) are retained for 30 days only.

Attention: To check the authenticity of testing /inspection report & certificate, please contact us at telephone: (86-755) 8307 1443, or email: CN.Doccheck@sgs.com  
 No.1 Workshop, M-10, Middle Section, Science & Technology Park, Nanshan District, Shenzhen, Guangdong, China 518057 t (86-755) 26012053 f (86-755) 26710594 www.sgs.com.cn  
 中国·广东·深圳市南山区科技园中区M-10栋1号厂房 邮编: 518057 t (86-755) 26012053 f (86-755) 26710594 sgs.china@sgs.com

2.4 26dB BW

2.4.1 Test Result

ENV	Mode	TX Type	Frequency (MHz)	RU	RU Pos	ANT	26dB Bandwidth (MHz)		Verdict
							Result	For Report Purpose	
NTNV	802.11ax (HE20)	MIMO	6435	RU242	Left	1	20.833	For Report Purpose	Pass
			6475	RU242	Left	1	20.738	For Report Purpose	Pass
			6515	RU242	Left	1	20.987	For Report Purpose	Pass
	802.11ax (HE40)	MIMO	6445	RU484	Left	1	40.302	For Report Purpose	Pass
			6485	RU484	Left	1	40.649	For Report Purpose	Pass
	802.11ax (HE80)	MIMO	6465	RU996	Left	1	82.041	For Report Purpose	Pass



Unless otherwise agreed in writing, this document is issued by the Company subject to its General Conditions of Service printed overleaf, available on request or accessible at <https://www.sgs.com/en/Terms-and-Conditions>. Attention is drawn to the limitation of liability, indemnification and jurisdiction issues defined therein. Any holder of this document is advised that information contained hereon reflects the Company's findings at the time of its intervention only and within the limits of Client's instructions, if any. The Company's sole responsibility is to its Client and this document does not exonerate parties to a transaction from exercising all their rights and obligations under the transaction documents. This document cannot be reproduced except in full, without prior written approval of the Company. Any unauthorized alteration, forgery or falsification of the content or appearance of this document is unlawful and offenders may be prosecuted to the fullest extent of the law. Unless otherwise stated the results shown in this test report refer only to the sample(s) tested and such sample(s) are retained for 30 days only.

Attention: To check the authenticity of testing /inspection report & certificate, please contact us at telephone: (86-755) 8307 1443, or email: CN.Doccheck@sgs.com



### 2.4.2 Test Graph

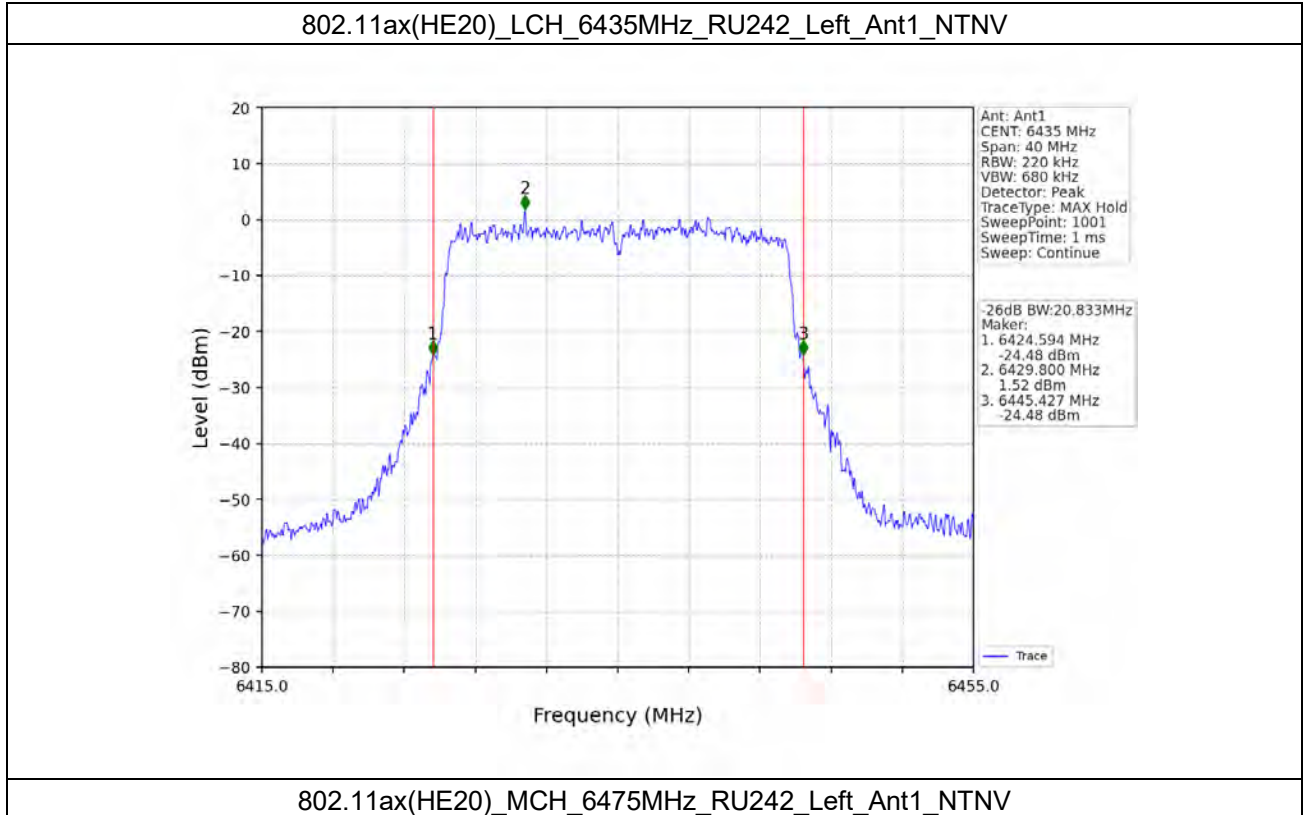

Unless otherwise agreed in writing, this document is issued by the Company subject to its General Conditions of Service printed overleaf, available on request or accessible at <https://www.sgs.com/en/Terms-and-Conditions>. Attention is drawn to the limitation of liability, indemnification and jurisdiction issues defined therein. Any holder of this document is advised that information contained hereon reflects the Company's findings at the time of its intervention only and within the limits of Client's instructions, if any. The Company's sole responsibility is to its Client and this document does not exonerate parties to a transaction from exercising all their rights and obligations under the transaction documents. This document cannot be reproduced except in full, without prior written approval of the Company. Any unauthorized alteration, forgery or falsification of the content or appearance of this document is unlawful and offenders may be prosecuted to the fullest extent of the law. Unless otherwise stated the results shown in this test report refer only to the sample(s) tested and such sample(s) are retained for 30 days only.

Attention: To check the authenticity of testing /inspection report & certificate, please contact us at telephone: (86-755) 8307 1443, or email: CN.Doccheck@sgs.com

No.1 Workshop, M-10, Middle Section, Science & Technology Park, Nanshan District, Shenzhen, Guangdong, China 518057 t (86-755) 26012053 f (86-755) 26710594 www.sgs.com.cn  
 中国·广东·深圳市南山区科技园中区M-10栋1号厂房 邮编: 518057 t (86-755) 26012053 f (86-755) 26710594 sgs.china@sgs.com



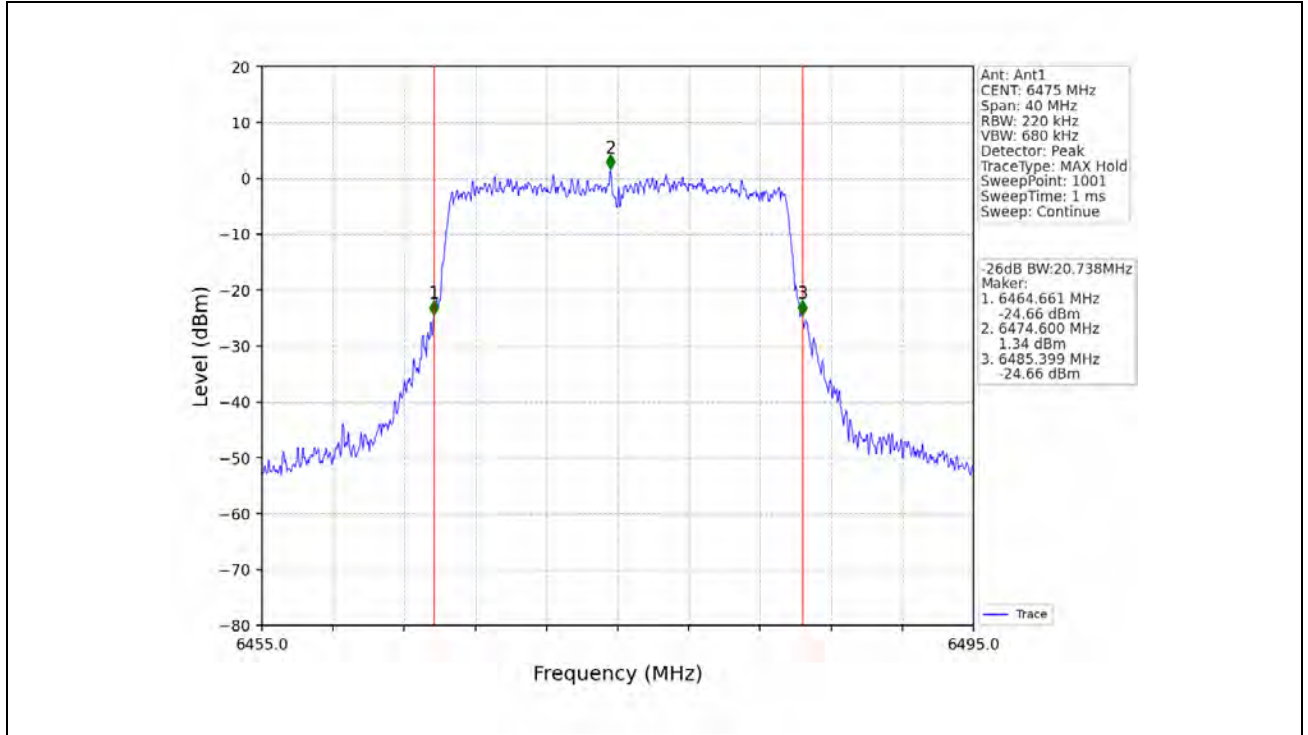

Unless otherwise agreed in writing, this document is issued by the Company subject to its General Conditions of Service printed overleaf, available on request or accessible at <https://www.sgs.com/en/Terms-and-Conditions>. Attention is drawn to the limitation of liability, indemnification and jurisdiction issues defined therein. Any holder of this document is advised that information contained hereon reflects the Company's findings at the time of its intervention only and within the limits of Client's instructions, if any. The Company's sole responsibility is to its Client and this document does not exonerate parties to a transaction from exercising all their rights and obligations under the transaction documents. This document cannot be reproduced except in full, without prior written approval of the Company. Any unauthorized alteration, forgery or falsification of the content or appearance of this document is unlawful and offenders may be prosecuted to the fullest extent of the law. Unless otherwise stated the results shown in this test report refer only to the sample(s) tested and such sample(s) are retained for 30 days only.

802.11ax(HE20)\_HCH\_6515MHz\_RU242\_Left\_Ant1\_NTNV

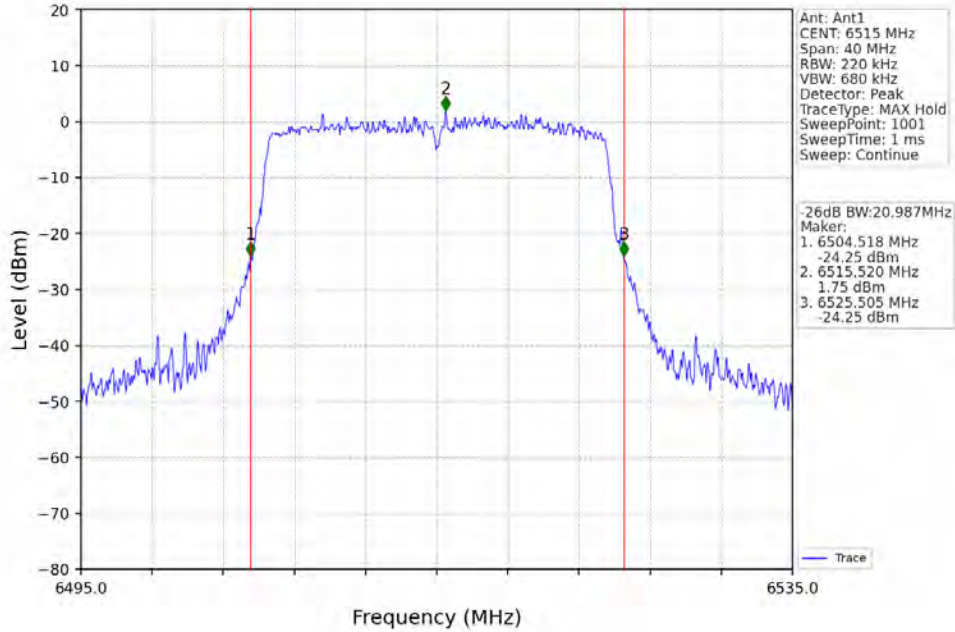

802.11ax(HE40)\_LCH\_6445MHz\_RU484\_Left\_Ant1\_NTNV

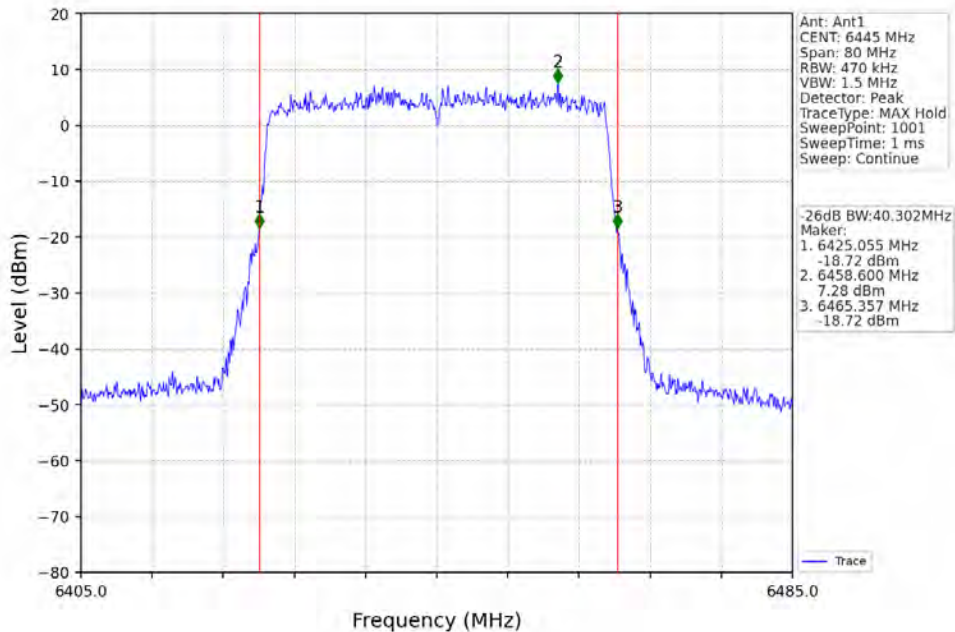

Unless otherwise agreed in writing, this document is issued by the Company subject to its General Conditions of Service printed overleaf, available on request or accessible at <https://www.sgs.com/en/Terms-and-Conditions>. Attention is drawn to the limitation of liability, indemnification and jurisdiction issues defined therein. Any holder of this document is advised that information contained hereon reflects the Company's findings at the time of its intervention only and within the limits of Client's instructions, if any. The Company's sole responsibility is to its Client and this document does not exonerate parties to a transaction from exercising all their rights and obligations under the transaction documents. This document cannot be reproduced except in full, without prior written approval of the Company. Any unauthorized alteration, forgery or falsification of the content or appearance of this document is unlawful and offenders may be prosecuted to the fullest extent of the law. Unless otherwise stated the results shown in this test report refer only to the sample(s) tested and such sample(s) are retained for 30 days only.

Attention: To check the authenticity of testing /inspection report & certificate, please contact us at telephone: (86-755) 8307 1443, or email: CN.Doccheck@sgs.com

802.11ax(HE40)\_MCH\_6485MHz\_RU484\_Left\_Ant1\_NTNV

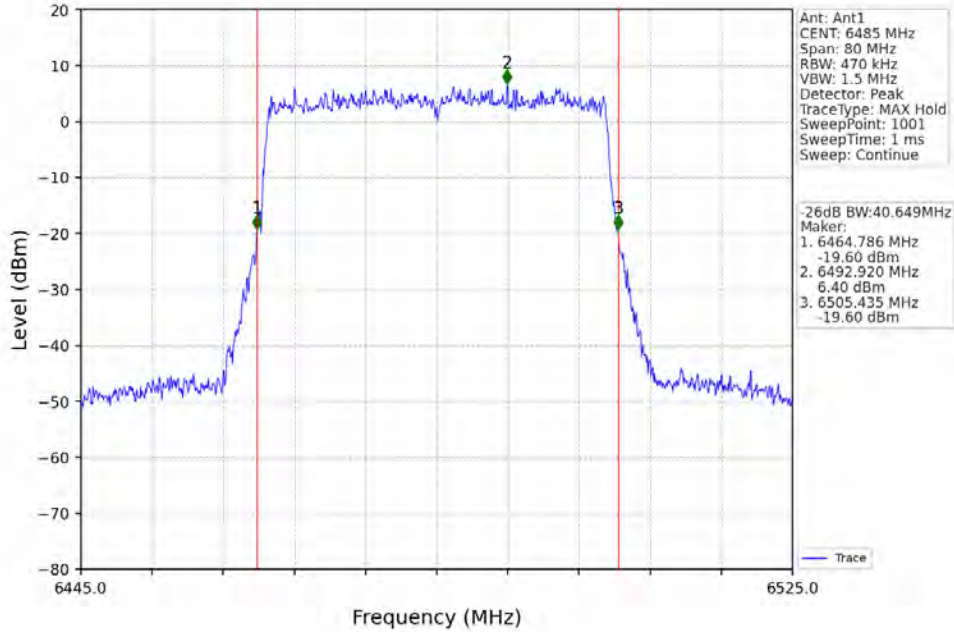

802.11ax(HE80)\_LCH\_6465MHz\_RU996\_Left\_Ant1\_NTNV

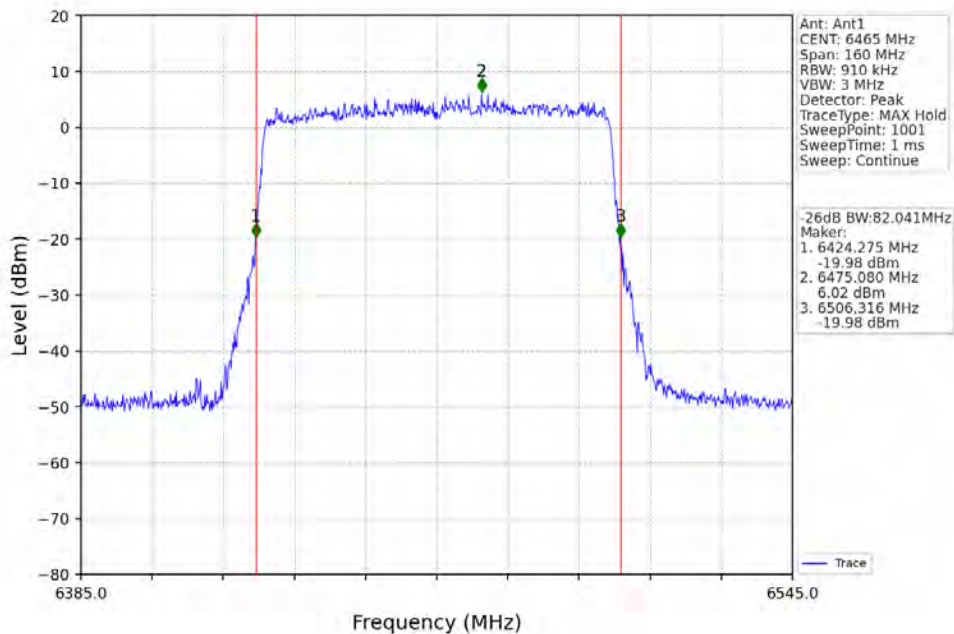

Unless otherwise agreed in writing, this document is issued by the Company subject to its General Conditions of Service printed overleaf, available on request or accessible at <https://www.sgs.com/en/Terms-and-Conditions>. Attention is drawn to the limitation of liability, indemnification and jurisdiction issues defined therein. Any holder of this document is advised that information contained hereon reflects the Company's findings at the time of its intervention only and within the limits of Client's instructions, if any. The Company's sole responsibility is to its Client and this document does not exonerate parties to a transaction from exercising all their rights and obligations under the transaction documents. This document cannot be reproduced except in full, without prior written approval of the Company. Any unauthorized alteration, forgery or falsification of the content or appearance of this document is unlawful and offenders may be prosecuted to the fullest extent of the law. Unless otherwise stated the results shown in this test report refer only to the sample(s) tested and such sample(s) are retained for 30 days only.



2.5 OBW

2.5.1 Test Result

ENV	Mode	TX Type	Frequency (MHz)	RU	RU Pos	ANT	99% Occupied Bandwidth (MHz)		Verdict
							Result	Limit	
NTNV	802.11ax (HE20)	MIMO	6535	RU242	Left	1	19.071	<=160	Pass
			6695	RU242	Left	1	19.080	<=160	Pass
			6855	RU242	Left	1	19.018	<=160	Pass
	802.11ax (HE40)	MIMO	6565	RU484	Left	1	37.988	<=160	Pass
			6685	RU484	Left	1	37.927	<=160	Pass
			6845	RU484	Left	1	37.920	<=160	Pass
	802.11ax (HE80)	MIMO	6625	RU996	Left	1	77.538	<=160	Pass
			6705	RU996	Left	1	77.489	<=160	Pass
			6785	RU996	Left	1	77.729	<=160	Pass
	802.11ax (HE160)	MIMO	6665	2xRU996	Left	1	156.518	<=160	Pass



Unless otherwise agreed in writing, this document is issued by the Company subject to its General Conditions of Service printed overleaf, available on request or accessible at <https://www.sgs.com/en/Terms-and-Conditions>. Attention is drawn to the limitation of liability, indemnification and jurisdiction issues defined therein. Any holder of this document is advised that information contained hereon reflects the Company's findings at the time of its intervention only and within the limits of Client's instructions, if any. The Company's sole responsibility is to its Client and this document does not exonerate parties to a transaction from exercising all their rights and obligations under the transaction documents. This document cannot be reproduced except in full, without prior written approval of the Company. Any unauthorized alteration, forgery or falsification of the content or appearance of this document is unlawful and offenders may be prosecuted to the fullest extent of the law. Unless otherwise stated the results shown in this test report refer only to the sample(s) tested and such sample(s) are retained for 30 days only.

Attention: To check the authenticity of testing /inspection report & certificate, please contact us at telephone: (86-755) 8307 1443, or email: CN.Doccheck@sgs.com  
 No.1 Workshop, M-10, Middle Section, Science & Technology Park, Nanshan District, Shenzhen, Guangdong, China 518057 t (86-755) 26012053 f (86-755) 26710594 www.sgs.com.cn  
 中国·广东·深圳市南山区科技园中区M-10栋1号厂房 邮编: 518057 t (86-755) 26012053 f (86-755) 26710594 sgs.china@sgs.com



### 2.5.2 Test Graph

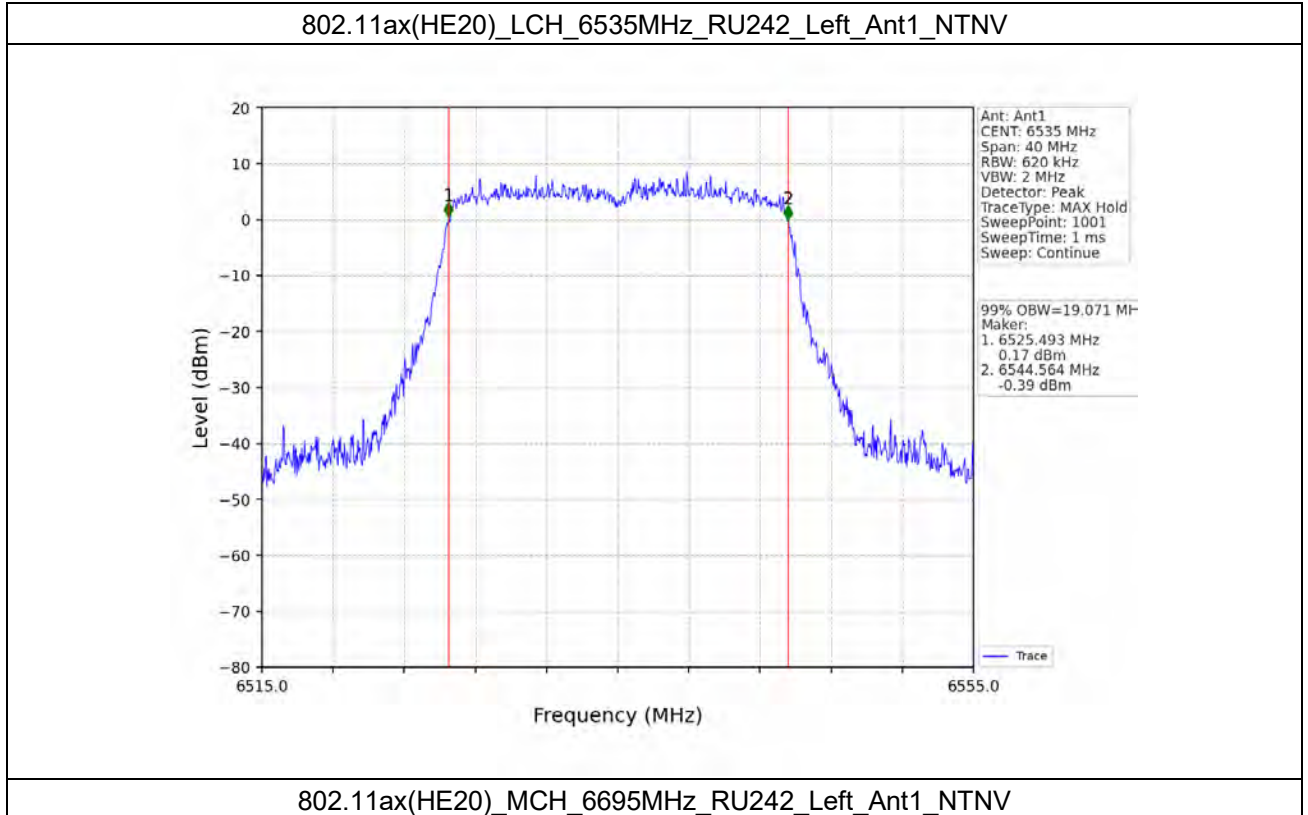

Unless otherwise agreed in writing, this document is issued by the Company subject to its General Conditions of Service printed overleaf, available on request or accessible at <https://www.sgs.com/en/Terms-and-Conditions>. Attention is drawn to the limitation of liability, indemnification and jurisdiction issues defined therein. Any holder of this document is advised that information contained hereon reflects the Company's findings at the time of its intervention only and within the limits of Client's instructions, if any. The Company's sole responsibility is to its Client and this document does not exonerate parties to a transaction from exercising all their rights and obligations under the transaction documents. This document cannot be reproduced except in full, without prior written approval of the Company. Any unauthorized alteration, forgery or falsification of the content or appearance of this document is unlawful and offenders may be prosecuted to the fullest extent of the law. Unless otherwise stated the results shown in this test report refer only to the sample(s) tested and such sample(s) are retained for 30 days only.

Attention: To check the authenticity of testing /inspection report & certificate, please contact us at telephone: (86-755) 8307 1443, or email: CN.Doccheck@sgs.com

No.1 Workshop, M-10, Middle Section, Science & Technology Park, Nanshan District, Shenzhen, Guangdong, China 518057 t (86-755) 26012053 f (86-755) 26710594 www.sgs.com.cn  
 中国·广东·深圳市南山区科技园中区M-10栋1号厂房 邮编: 518057 t (86-755) 26012053 f (86-755) 26710594 sgs.china@sgs.com

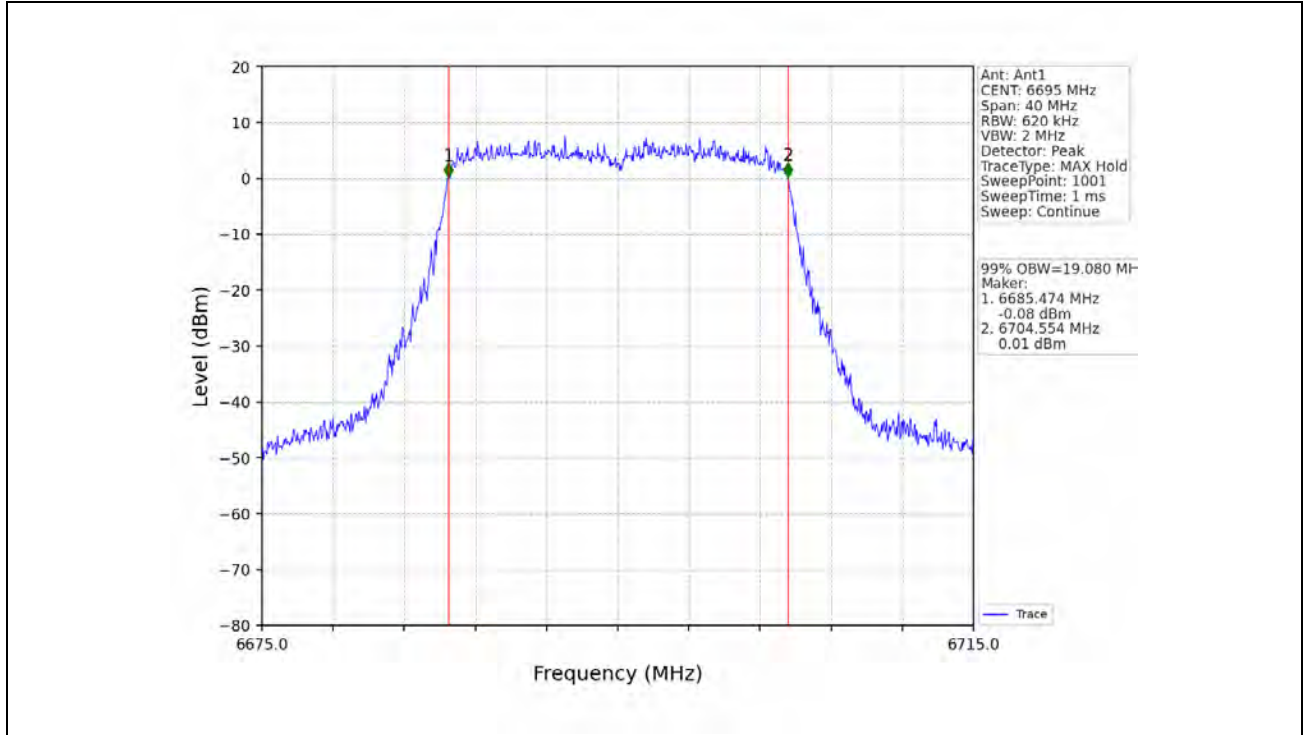

Unless otherwise agreed in writing, this document is issued by the Company subject to its General Conditions of Service printed overleaf, available on request or accessible at <https://www.sgs.com/en/Terms-and-Conditions>. Attention is drawn to the limitation of liability, indemnification and jurisdiction issues defined therein. Any holder of this document is advised that information contained hereon reflects the Company's findings at the time of its intervention only and within the limits of Client's instructions, if any. The Company's sole responsibility is to its Client and this document does not exonerate parties to a transaction from exercising all their rights and obligations under the transaction documents. This document cannot be reproduced except in full, without prior written approval of the Company. Any unauthorized alteration, forgery or falsification of the content or appearance of this document is unlawful and offenders may be prosecuted to the fullest extent of the law. Unless otherwise stated the results shown in this test report refer only to the sample(s) tested and such sample(s) are retained for 30 days only.

Attention: To check the authenticity of testing /inspection report & certificate, please contact us at telephone: (86-755) 8307 1443, or email: [CN.Doccheck@sgs.com](mailto:CN.Doccheck@sgs.com)  
 No.1 Workshop, M-10, Middle Section, Science & Technology Park, Nanshan District, Shenzhen, Guangdong, China 518057 t (86-755) 26012053 f (86-755) 26710594 www.sgs.com.cn  
 中国·广东·深圳市南山区科技园中区M-10栋1号厂房 邮编: 518057 t (86-755) 26012053 f (86-755) 26710594 sgs.china@sgs.com

802.11ax(HE20)\_HCH\_6855MHz\_RU242\_Left\_Ant1\_NTNV

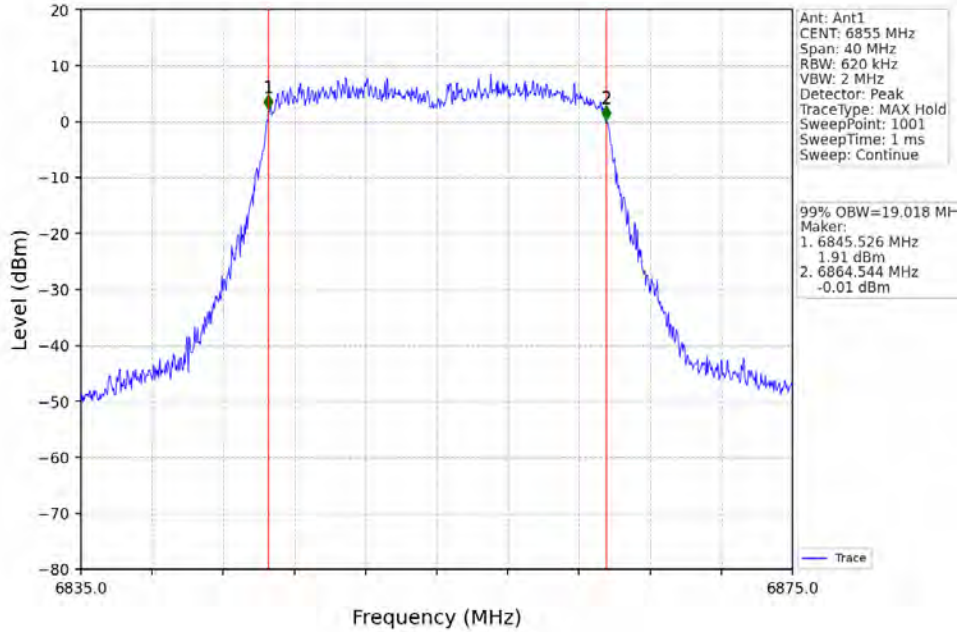

802.11ax(HE40)\_LCH\_6565MHz\_RU484\_Left\_Ant1\_NTNV

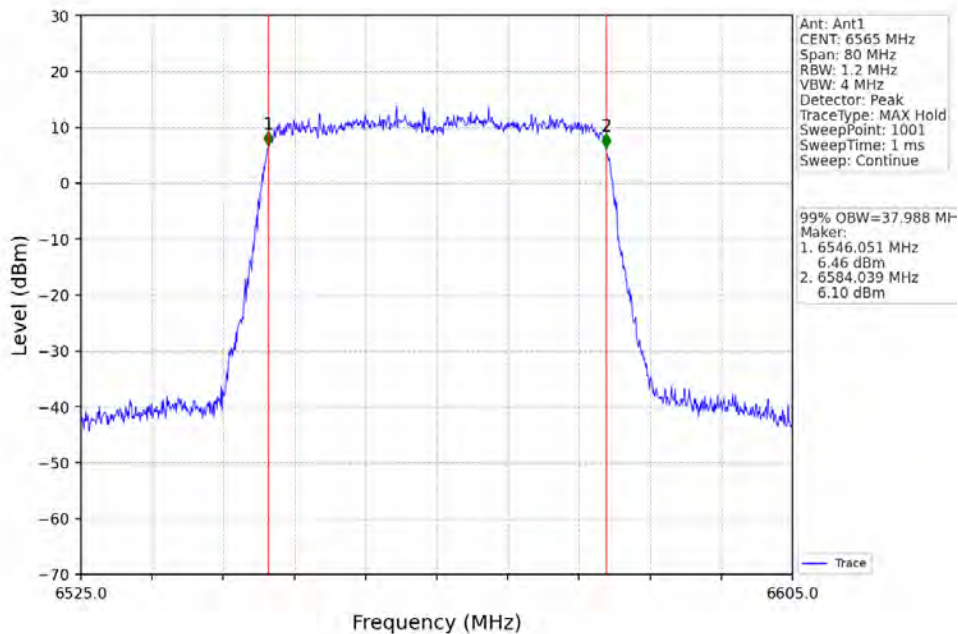

Unless otherwise agreed in writing, this document is issued by the Company subject to its General Conditions of Service printed overleaf, available on request or accessible at <https://www.sgs.com/en/Terms-and-Conditions>. Attention is drawn to the limitation of liability, indemnification and jurisdiction issues defined therein. Any holder of this document is advised that information contained hereon reflects the Company's findings at the time of its intervention only and within the limits of Client's instructions, if any. The Company's sole responsibility is to its Client and this document does not exonerate parties to a transaction from exercising all their rights and obligations under the transaction documents. This document cannot be reproduced except in full, without prior written approval of the Company. Any unauthorized alteration, forgery or falsification of the content or appearance of this document is unlawful and offenders may be prosecuted to the fullest extent of the law. Unless otherwise stated the results shown in this test report refer only to the sample(s) tested and such sample(s) are retained for 30 days only.

Attention: To check the authenticity of testing /inspection report & certificate, please contact us at telephone: (86-755) 8307 1443, or email: CN.Doccheck@sgs.com



### 802.11ax(HE40)\_MCH\_6685MHz\_RU484\_Left\_Ant1\_NTNV

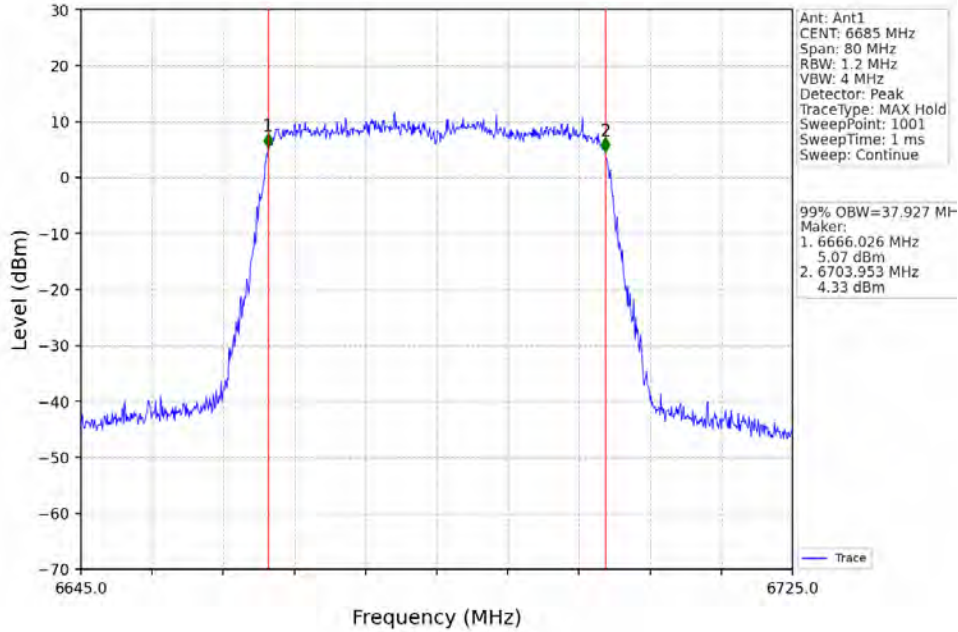

### 802.11ax(HE40)\_HCH\_6845MHz\_RU484\_Left\_Ant1\_NTNV

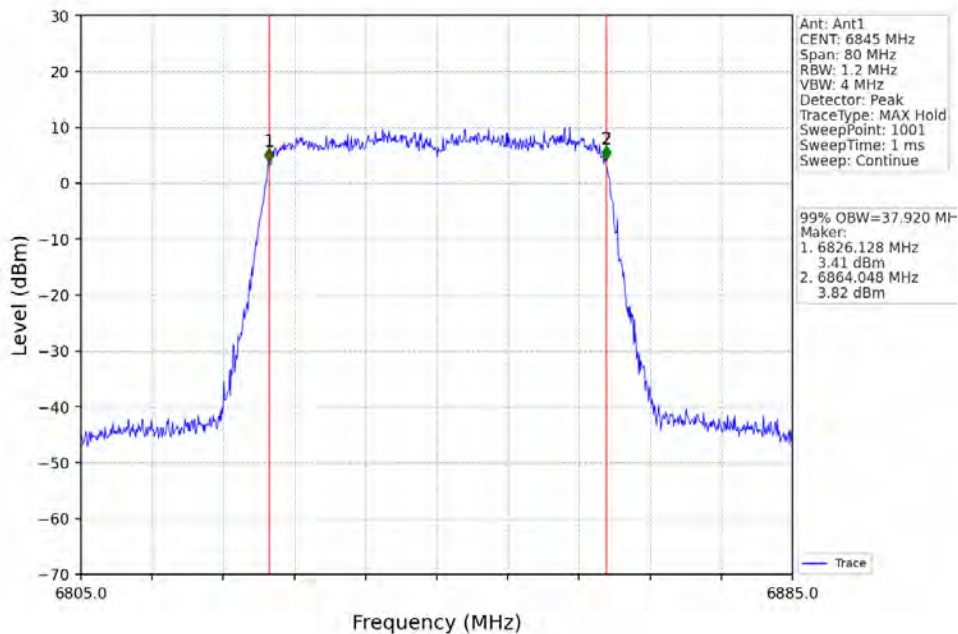

Unless otherwise agreed in writing, this document is issued by the Company subject to its General Conditions of Service printed overleaf, available on request or accessible at <https://www.sgs.com/en/Terms-and-Conditions>. Attention is drawn to the limitation of liability, indemnification and jurisdiction issues defined therein. Any holder of this document is advised that information contained hereon reflects the Company's findings at the time of its intervention only and within the limits of Client's instructions, if any. The Company's sole responsibility is to its Client and this document does not exonerate parties to a transaction from exercising all their rights and obligations under the transaction documents. This document cannot be reproduced except in full, without prior written approval of the Company. Any unauthorized alteration, forgery or falsification of the content or appearance of this document is unlawful and offenders may be prosecuted to the fullest extent of the law. Unless otherwise stated the results shown in this test report refer only to the sample(s) tested and such sample(s) are retained for 30 days only.



802.11ax(HE80)\_LCH\_6625MHz\_RU996\_Left\_Ant1\_NTNV

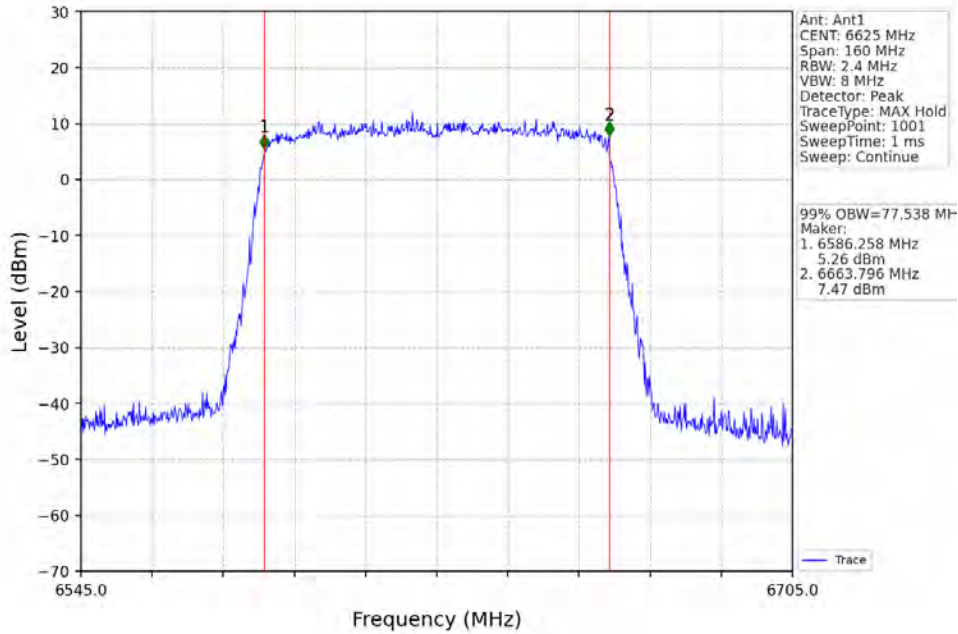

802.11ax(HE80)\_MCH\_6705MHz\_RU996\_Left\_Ant1\_NTNV

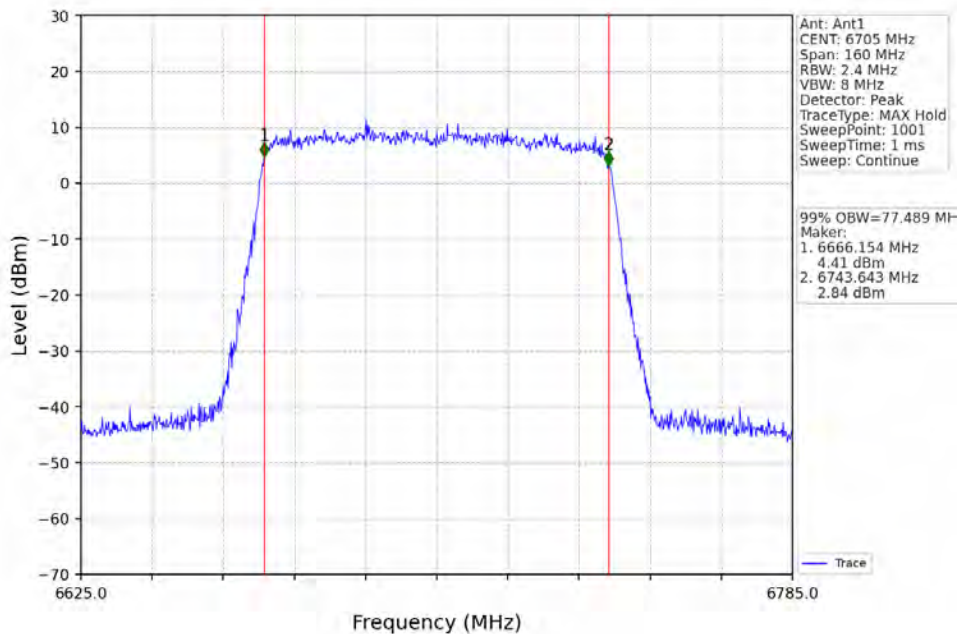

Unless otherwise agreed in writing, this document is issued by the Company subject to its General Conditions of Service printed overleaf, available on request or accessible at <https://www.sgs.com/en/Terms-and-Conditions>. Attention is drawn to the limitation of liability, indemnification and jurisdiction issues defined therein. Any holder of this document is advised that information contained hereon reflects the Company's findings at the time of its intervention only and within the limits of Client's instructions, if any. The Company's sole responsibility is to its Client and this document does not exonerate parties to a transaction from exercising all their rights and obligations under the transaction documents. This document cannot be reproduced except in full, without prior written approval of the Company. Any unauthorized alteration, forgery or falsification of the content or appearance of this document is unlawful and offenders may be prosecuted to the fullest extent of the law. Unless otherwise stated the results shown in this test report refer only to the sample(s) tested and such sample(s) are retained for 30 days only.

Attention: To check the authenticity of testing /inspection report & certificate, please contact us at telephone: (86-755) 8307 1443, or email: CN.Doccheck@sgs.com



802.11ax(HE80)\_HCH\_6785MHz\_RU996\_Left\_Ant1\_NTNV

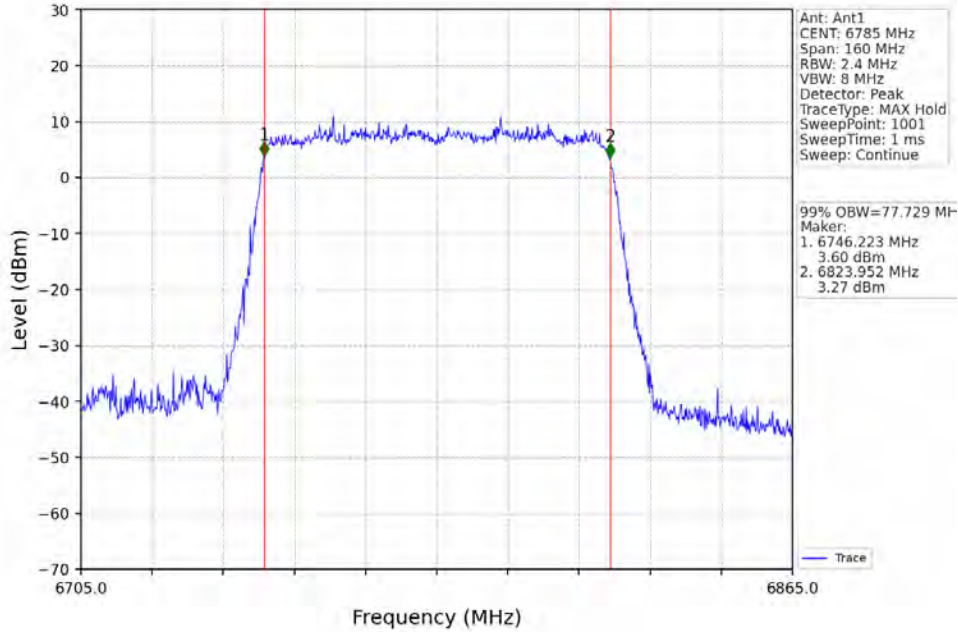

802.11ax(HE160)\_MCH\_6665MHz\_2xRU996\_Left\_Ant1\_NTNV

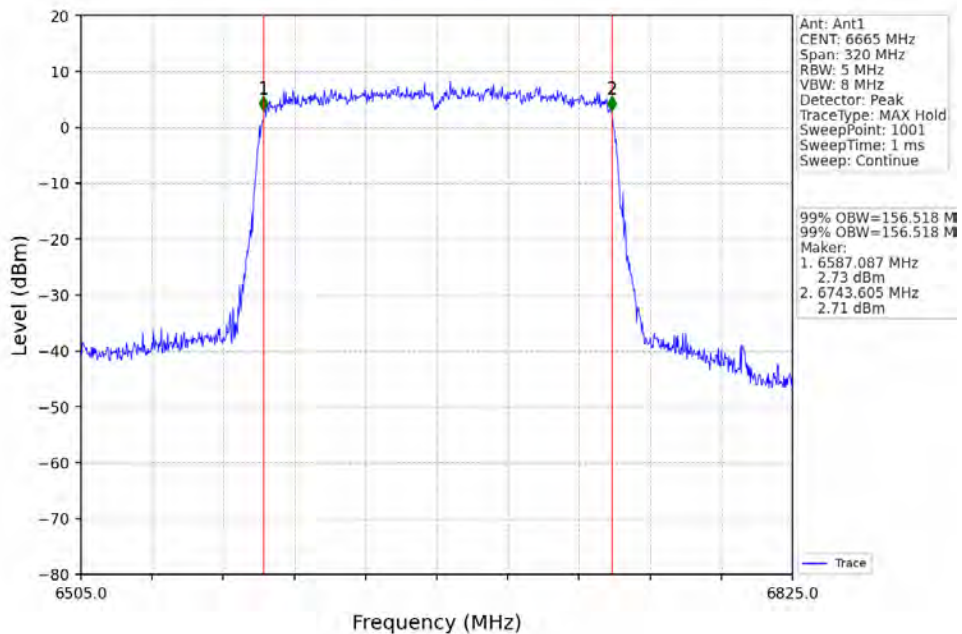

Unless otherwise agreed in writing, this document is issued by the Company subject to its General Conditions of Service printed overleaf, available on request or accessible at <https://www.sgs.com/en/Terms-and-Conditions>. Attention is drawn to the limitation of liability, indemnification and jurisdiction issues defined therein. Any holder of this document is advised that information contained hereon reflects the Company's findings at the time of its intervention only and within the limits of Client's instructions, if any. The Company's sole responsibility is to its Client and this document does not exonerate parties to a transaction from exercising all their rights and obligations under the transaction documents. This document cannot be reproduced except in full, without prior written approval of the Company. Any unauthorized alteration, forgery or falsification of the content or appearance of this document is unlawful and offenders may be prosecuted to the fullest extent of the law. Unless otherwise stated the results shown in this test report refer only to the sample(s) tested and such sample(s) are retained for 30 days only.

Attention: To check the authenticity of testing /inspection report & certificate, please contact us at telephone: (86-755) 8307 1443, or email: CN.Doccheck@sgs.com  
 No.1 Workshop, M-10, Middle Section, Science & Technology Park, Nanshan District, Shenzhen, Guangdong, China 518057 t (86-755) 26012053 f (86-755) 26710594 www.sgs.com.cn  
 中国·广东·深圳市南山区科技园中区M-10栋1号厂房 邮编: 518057 t (86-755) 26012053 f (86-755) 26710594 sgs.china@sgs.com



2.6 26dB BW

2.6.1 Test Result

ENV	Mode	TX Type	Frequency (MHz)	RU	RU Pos	ANT	26dB Bandwidth (MHz)		Verdict
							Result	Limit	
NTNV	802.11ax (HE20)	MIMO	6535	RU242	Left	1	20.996	For Report Purpose	Pass
			6695	RU242	Left	1	20.941	For Report Purpose	Pass
			6855	RU242	Left	1	20.791	For Report Purpose	Pass
	802.11ax (HE40)	MIMO	6565	RU484	Left	1	40.489	For Report Purpose	Pass
			6685	RU484	Left	1	40.256	For Report Purpose	Pass
			6845	RU484	Left	1	40.141	For Report Purpose	Pass
	802.11ax (HE80)	MIMO	6625	RU996	Left	1	81.846	For Report Purpose	Pass
			6705	RU996	Left	1	81.983	For Report Purpose	Pass
			6785	RU996	Left	1	83.032	For Report Purpose	Pass
	802.11ax (HE160)	MIMO	6665	2xRU996	Left	1	163.831	For Report Purpose	Pass



Unless otherwise agreed in writing, this document is issued by the Company subject to its General Conditions of Service printed overleaf, available on request or accessible at <https://www.sgs.com/en/Terms-and-Conditions>. Attention is drawn to the limitation of liability, indemnification and jurisdiction issues defined therein. Any holder of this document is advised that information contained hereon reflects the Company's findings at the time of its intervention only and within the limits of Client's instructions, if any. The Company's sole responsibility is to its Client and this document does not exonerate parties to a transaction from exercising all their rights and obligations under the transaction documents. This document cannot be reproduced except in full, without prior written approval of the Company. Any unauthorized alteration, forgery or falsification of the content or appearance of this document is unlawful and offenders may be prosecuted to the fullest extent of the law. Unless otherwise stated the results shown in this test report refer only to the sample(s) tested and such sample(s) are retained for 30 days only.

Attention: To check the authenticity of testing /inspection report & certificate, please contact us at telephone: (86-755) 8307 1443, or email: CN.Doccheck@sgs.com  
 No.1 Workshop, M-10, Middle Section, Science & Technology Park, Nanshan District, Shenzhen, Guangdong, China 518057 t (86-755) 26012053 f (86-755) 26710594 www.sgs.com.cn  
 中国·广东·深圳市南山区科技园中区M-10栋1号厂房 邮编: 518057 t (86-755) 26012053 f (86-755) 26710594 sgs.china@sgs.com



2.6.2 Test Graph

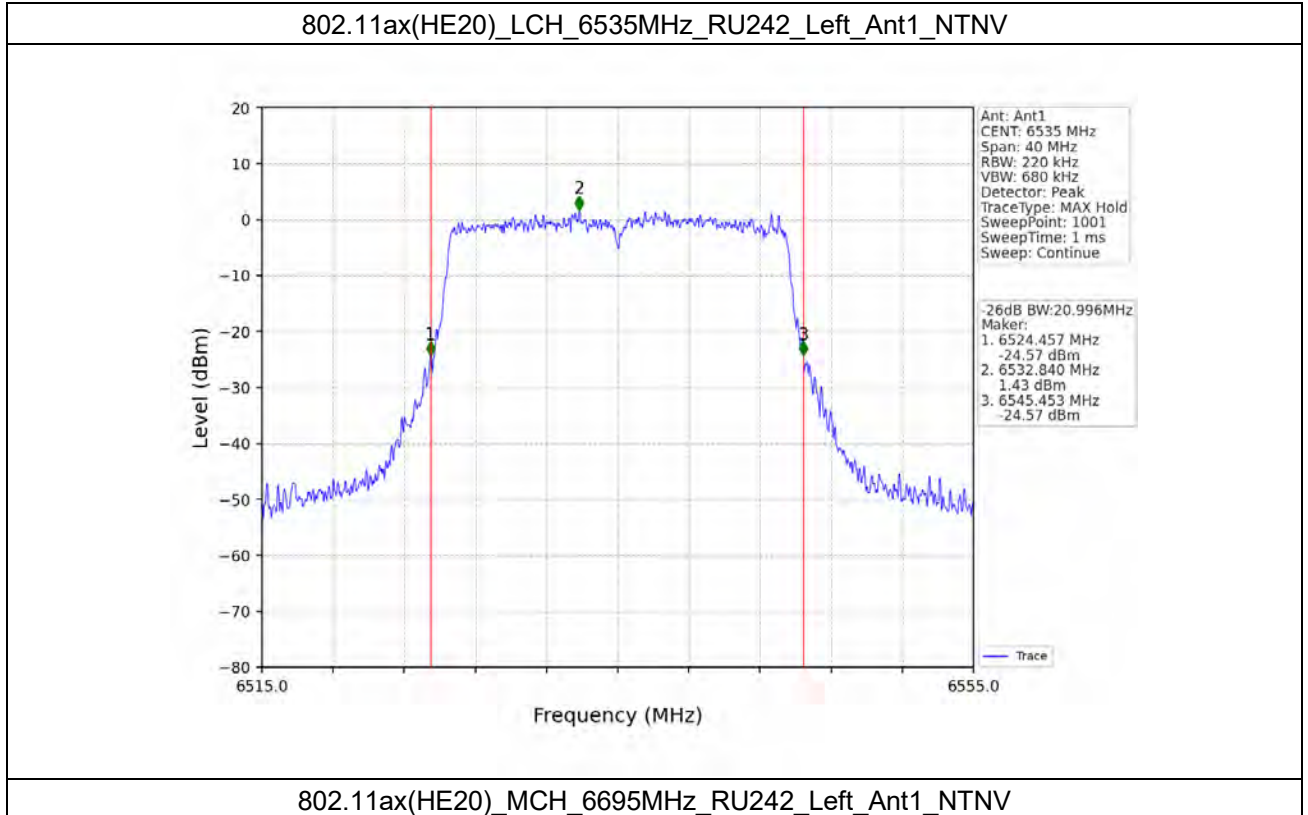

Unless otherwise agreed in writing, this document is issued by the Company subject to its General Conditions of Service printed overleaf, available on request or accessible at <https://www.sgs.com/en/Terms-and-Conditions>. Attention is drawn to the limitation of liability, indemnification and jurisdiction issues defined therein. Any holder of this document is advised that information contained hereon reflects the Company's findings at the time of its intervention only and within the limits of Client's instructions, if any. The Company's sole responsibility is to its Client and this document does not exonerate parties to a transaction from exercising all their rights and obligations under the transaction documents. This document cannot be reproduced except in full, without prior written approval of the Company. Any unauthorized alteration, forgery or falsification of the content or appearance of this document is unlawful and offenders may be prosecuted to the fullest extent of the law. Unless otherwise stated the results shown in this test report refer only to the sample(s) tested and such sample(s) are retained for 30 days only.

Attention: To check the authenticity of testing /inspection report & certificate, please contact us at telephone: (86-755) 8307 1443, or email: CN.Doccheck@sgs.com

SGS-CSTC Standards Technical Services Co., Ltd. Shenzhen Branch  
 No.1 Workshop, M-10, Middle Section, Science & Technology Park, Nanshan District, Shenzhen, Guangdong, China 518057 t (86-755) 26012053 f (86-755) 26710594 www.sgs.com.cn  
 中国·广东·深圳市南山区科技园中区M-10栋1号厂房 邮编: 518057 t (86-755) 26012053 f (86-755) 26710594 sgs.china@sgs.com



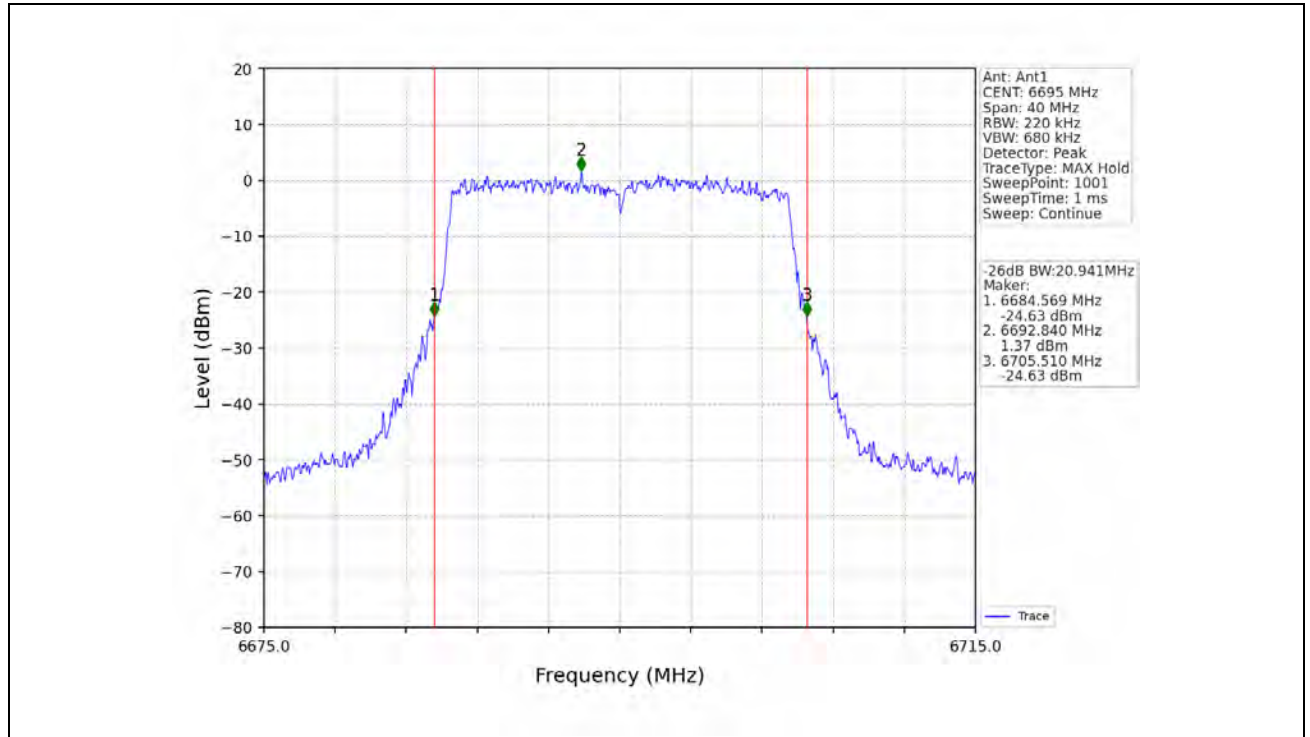

Unless otherwise agreed in writing, this document is issued by the Company subject to its General Conditions of Service printed overleaf, available on request or accessible at <https://www.sgs.com/en/Terms-and-Conditions>. Attention is drawn to the limitation of liability, indemnification and jurisdiction issues defined therein. Any holder of this document is advised that information contained hereon reflects the Company's findings at the time of its intervention only and within the limits of Client's instructions, if any. The Company's sole responsibility is to its Client and this document does not exonerate parties to a transaction from exercising all their rights and obligations under the transaction documents. This document cannot be reproduced except in full, without prior written approval of the Company. Any unauthorized alteration, forgery or falsification of the content or appearance of this document is unlawful and offenders may be prosecuted to the fullest extent of the law. Unless otherwise stated the results shown in this test report refer only to the sample(s) tested and such sample(s) are retained for 30 days only.

Attention: To check the authenticity of testing /inspection report & certificate, please contact us at telephone: (86-755) 8307 1443, or email: CN.Doccheck@sgs.com

No.1 Workshop, M-10, Middle Section, Science & Technology Park, Nanshan District, Shenzhen, Guangdong, China 518057 t (86-755) 26012053 f (86-755) 26710594 www.sgsgroup.com.cn  
 中国·广东·深圳市南山区科技园中区M-10栋1号厂房 邮编: 518057 t (86-755) 26012053 f (86-755) 26710594 sgs.china@sgs.com

802.11ax(HE20)\_HCH\_6855MHz\_RU242\_Left\_Ant1\_NTNV

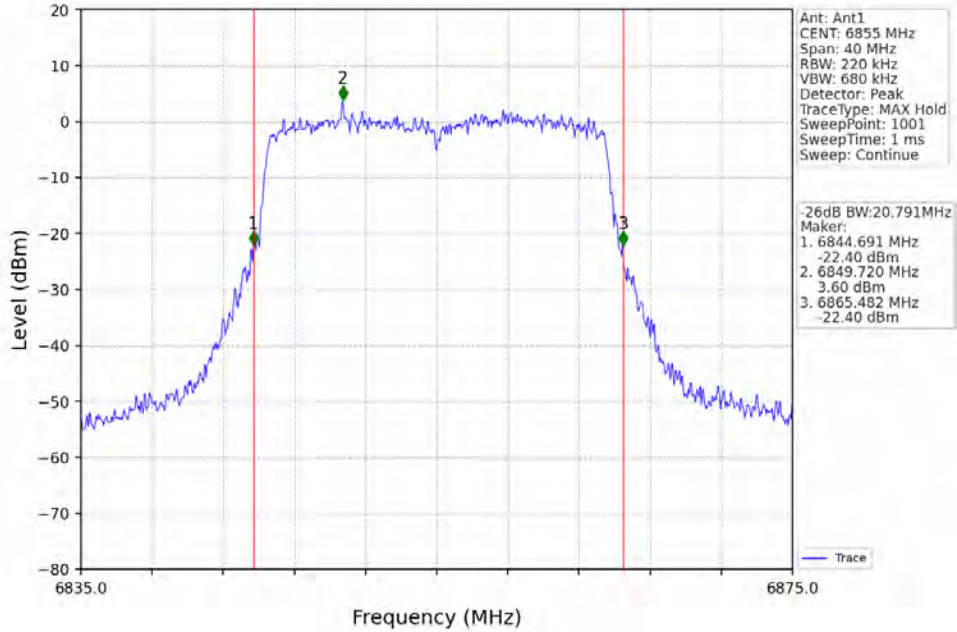

802.11ax(HE40)\_LCH\_6565MHz\_RU484\_Left\_Ant1\_NTNV

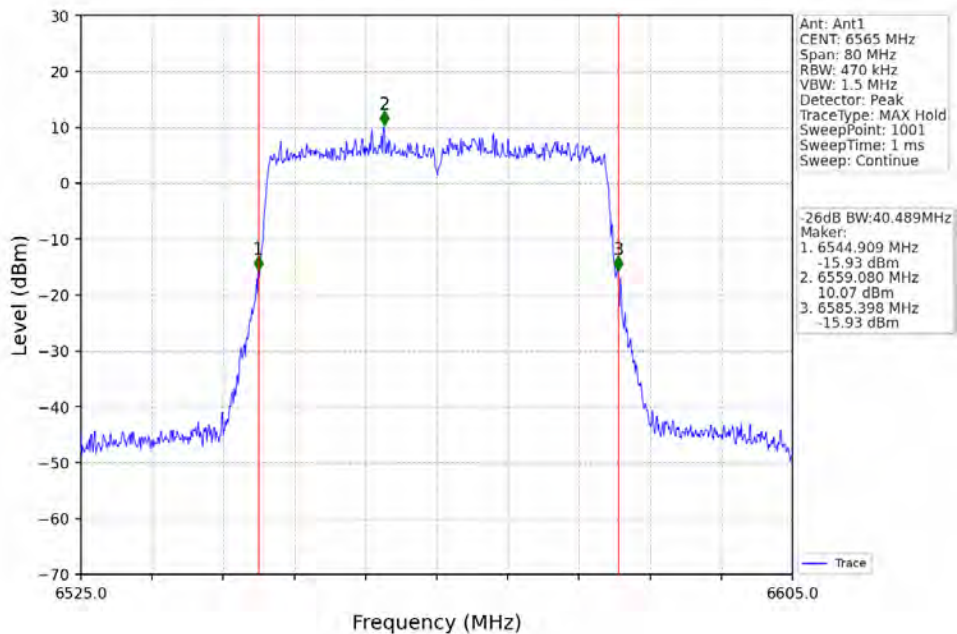

Unless otherwise agreed in writing, this document is issued by the Company subject to its General Conditions of Service printed overleaf, available on request or accessible at <https://www.sgs.com/en/Terms-and-Conditions>. Attention is drawn to the limitation of liability, indemnification and jurisdiction issues defined therein. Any holder of this document is advised that information contained hereon reflects the Company's findings at the time of its intervention only and within the limits of Client's instructions, if any. The Company's sole responsibility is to its Client and this document does not exonerate parties to a transaction from exercising all their rights and obligations under the transaction documents. This document cannot be reproduced except in full, without prior written approval of the Company. Any unauthorized alteration, forgery or falsification of the content or appearance of this document is unlawful and offenders may be prosecuted to the fullest extent of the law. Unless otherwise stated the results shown in this test report refer only to the sample(s) tested and such sample(s) are retained for 30 days only.

Attention: To check the authenticity of testing /inspection report & certificate, please contact us at telephone: (86-755) 8307 1443, or email: CN.Doccheck@sgs.com

### 802.11ax(HE40)\_MCH\_6685MHz\_RU484\_Left\_Ant1\_NTNV

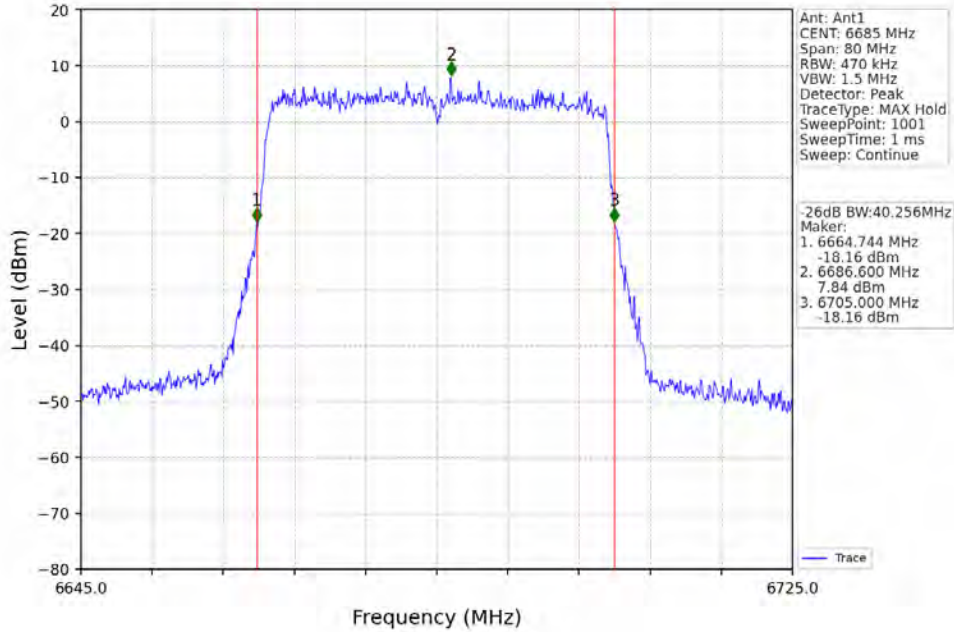

### 802.11ax(HE40)\_HCH\_6845MHz\_RU484\_Left\_Ant1\_NTNV

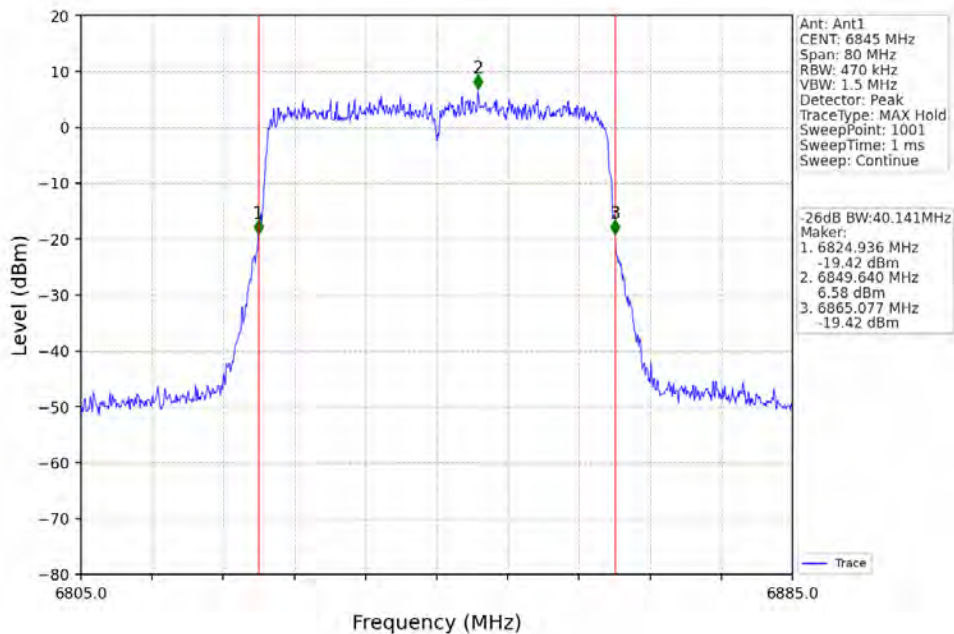

Unless otherwise agreed in writing, this document is issued by the Company subject to its General Conditions of Service printed overleaf, available on request or accessible at <https://www.sgs.com/en/Terms-and-Conditions>. Attention is drawn to the limitation of liability, indemnification and jurisdiction issues defined therein. Any holder of this document is advised that information contained hereon reflects the Company's findings at the time of its intervention only and within the limits of Client's instructions, if any. The Company's sole responsibility is to its Client and this document does not exonerate parties to a transaction from exercising all their rights and obligations under the transaction documents. This document cannot be reproduced except in full, without prior written approval of the Company. Any unauthorized alteration, forgery or falsification of the content or appearance of this document is unlawful and offenders may be prosecuted to the fullest extent of the law. Unless otherwise stated the results shown in this test report refer only to the sample(s) tested and such sample(s) are retained for 30 days only.

Attention: To check the authenticity of testing /inspection report & certificate, please contact us at telephone: (86-755) 8307 1443, or email: CN.Doccheck@sgs.com



SGS-CSTC Standards Technical Services Co., Ltd.  
Shenzhen Branch

No.1 Workshop, M-10, Middle Section, Science & Technology Park, Nanshan District, Shenzhen, Guangdong, China 518057 t (86-755) 26012053 f (86-755) 26710594 www.sgs.com.cn  
中国·广东·深圳市南山区科技园中区M-10栋1号厂房 邮编: 518057 t (86-755) 26012053 f (86-755) 26710594 sgs.china@sgs.com



802.11ax(HE80)\_LCH\_6625MHz\_RU996\_Left\_Ant1\_NTNV

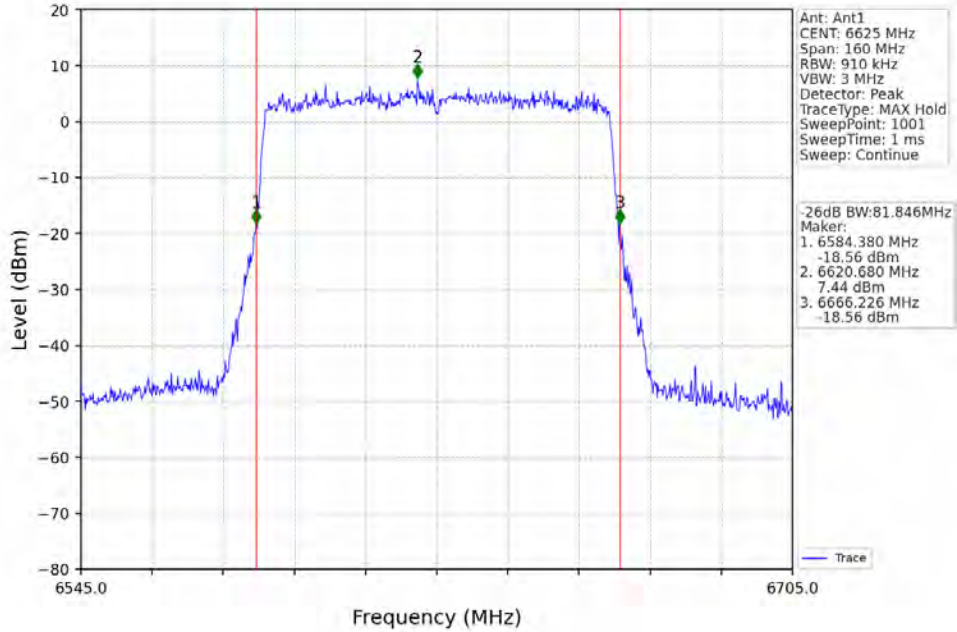

802.11ax(HE80)\_MCH\_6705MHz\_RU996\_Left\_Ant1\_NTNV

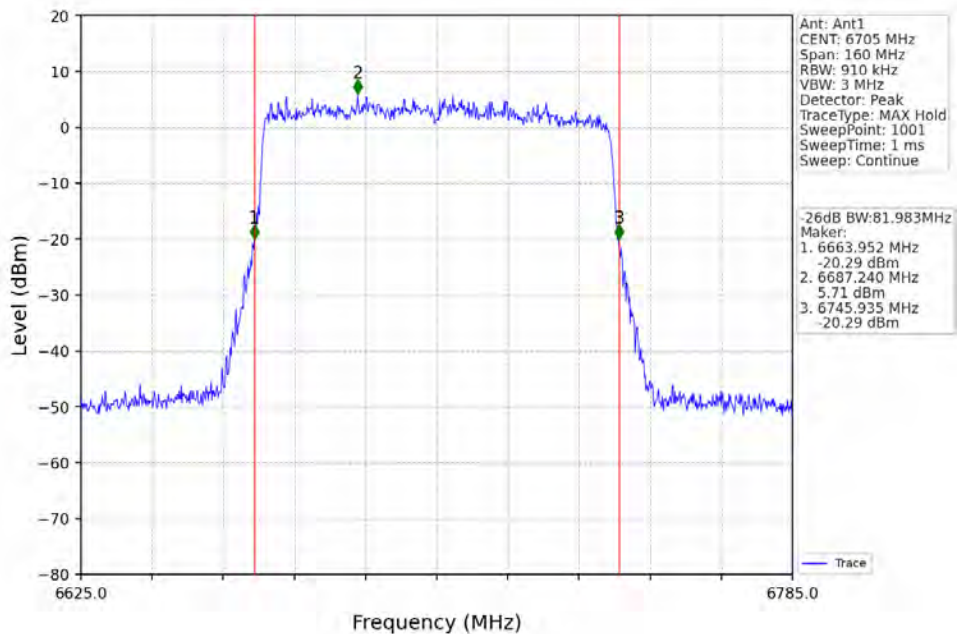

Unless otherwise agreed in writing, this document is issued by the Company subject to its General Conditions of Service printed overleaf, available on request or accessible at <https://www.sgs.com/en/Terms-and-Conditions>. Attention is drawn to the limitation of liability, indemnification and jurisdiction issues defined therein. Any holder of this document is advised that information contained hereon reflects the Company's findings at the time of its intervention only and within the limits of Client's instructions, if any. The Company's sole responsibility is to its Client and this document does not exonerate parties to a transaction from exercising all their rights and obligations under the transaction documents. This document cannot be reproduced except in full, without prior written approval of the Company. Any unauthorized alteration, forgery or falsification of the content or appearance of this document is unlawful and offenders may be prosecuted to the fullest extent of the law. Unless otherwise stated the results shown in this test report refer only to the sample(s) tested and such sample(s) are retained for 30 days only.

Attention: To check the authenticity of testing /inspection report & certificate, please contact us at telephone: (86-755) 8307 1443, or email: CN.Doccheck@sgs.com

802.11ax(HE80)\_HCH\_6785MHz\_RU996\_Left\_Ant1\_NTNV

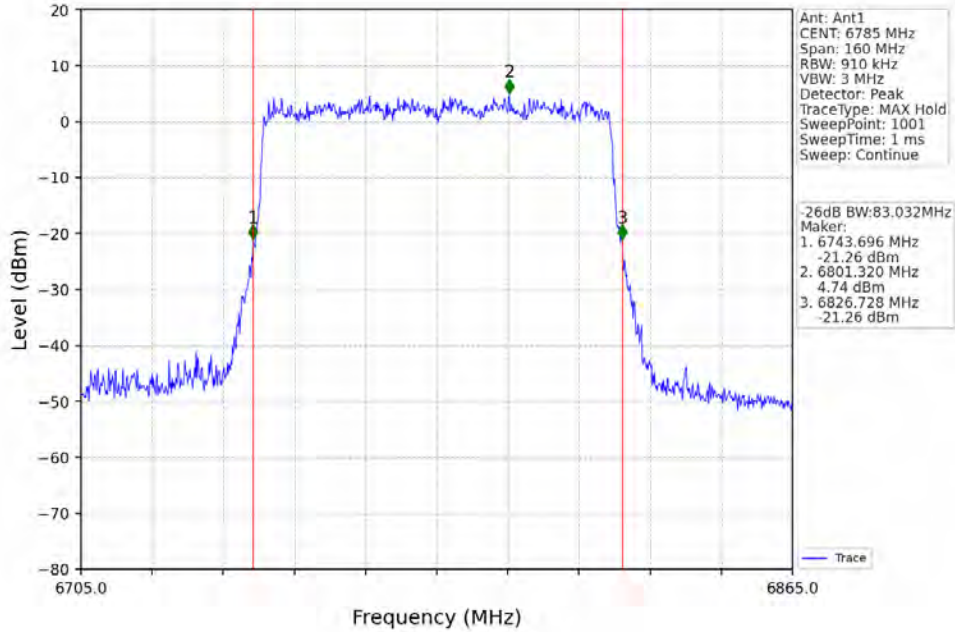

802.11ax(HE160)\_MCH\_6665MHz\_2xRU996\_Left\_Ant1\_NTNV

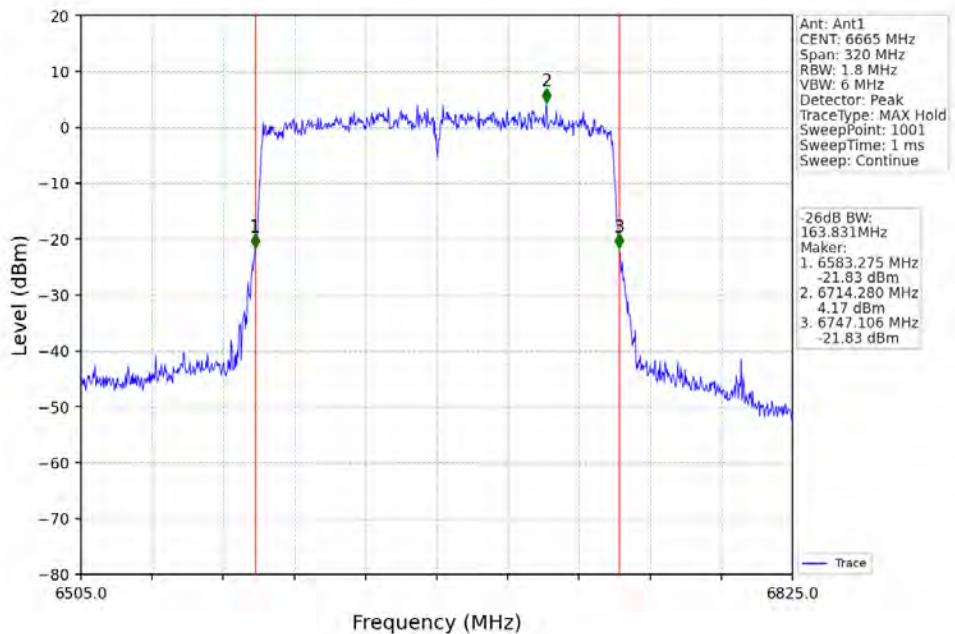

Unless otherwise agreed in writing, this document is issued by the Company subject to its General Conditions of Service printed overleaf, available on request or accessible at <https://www.sgs.com/en/Terms-and-Conditions>. Attention is drawn to the limitation of liability, indemnification and jurisdiction issues defined therein. Any holder of this document is advised that information contained hereon reflects the Company's findings at the time of its intervention only and within the limits of Client's instructions, if any. The Company's sole responsibility is to its Client and this document does not exonerate parties to a transaction from exercising all their rights and obligations under the transaction documents. This document cannot be reproduced except in full, without prior written approval of the Company. Any unauthorized alteration, forgery or falsification of the content or appearance of this document is unlawful and offenders may be prosecuted to the fullest extent of the law. Unless otherwise stated the results shown in this test report refer only to the sample(s) tested and such sample(s) are retained for 30 days only.

2.7 OBW

2.7.1 Test Result

ENV	Mode	TX Type	Frequency (MHz)	RU	RU Pos	ANT	99% Occupied Bandwidth (MHz)		Verdict
							Result	Limit	
NTNV	802.11ax (HE20)	MIMO	6895	RU242	Left	1	18.987	<=160	Pass
			6995	RU242	Left	1	19.073	<=160	Pass
			7115	RU242	Left	1	19.098	<=160	Pass
	802.11ax (HE40)	MIMO	6925	RU484	Left	1	37.922	<=160	Pass
			7005	RU484	Left	1	37.872	<=160	Pass
			7085	RU484	Left	1	37.902	<=160	Pass
	802.11ax (HE80)	MIMO	6945	RU996	Left	1	77.500	<=160	Pass
			7025	RU996	Left	1	77.577	<=160	Pass
	802.11ax (HE160)	MIMO	6985	2xRU996	Left	1	156.544	<=160	Pass



Unless otherwise agreed in writing, this document is issued by the Company subject to its General Conditions of Service printed overleaf, available on request or accessible at <https://www.sgs.com/en/Terms-and-Conditions>. Attention is drawn to the limitation of liability, indemnification and jurisdiction issues defined therein. Any holder of this document is advised that information contained hereon reflects the Company's findings at the time of its intervention only and within the limits of Client's instructions, if any. The Company's sole responsibility is to its Client and this document does not exonerate parties to a transaction from exercising all their rights and obligations under the transaction documents. This document cannot be reproduced except in full, without prior written approval of the Company. Any unauthorized alteration, forgery or falsification of the content or appearance of this document is unlawful and offenders may be prosecuted to the fullest extent of the law. Unless otherwise stated the results shown in this test report refer only to the sample(s) tested and such sample(s) are retained for 30 days only.

Attention: To check the authenticity of testing /inspection report & certificate, please contact us at telephone: (86-755) 8307 1443, or email: CN.Doccheck@sgs.com



2.7.2 Test Graph

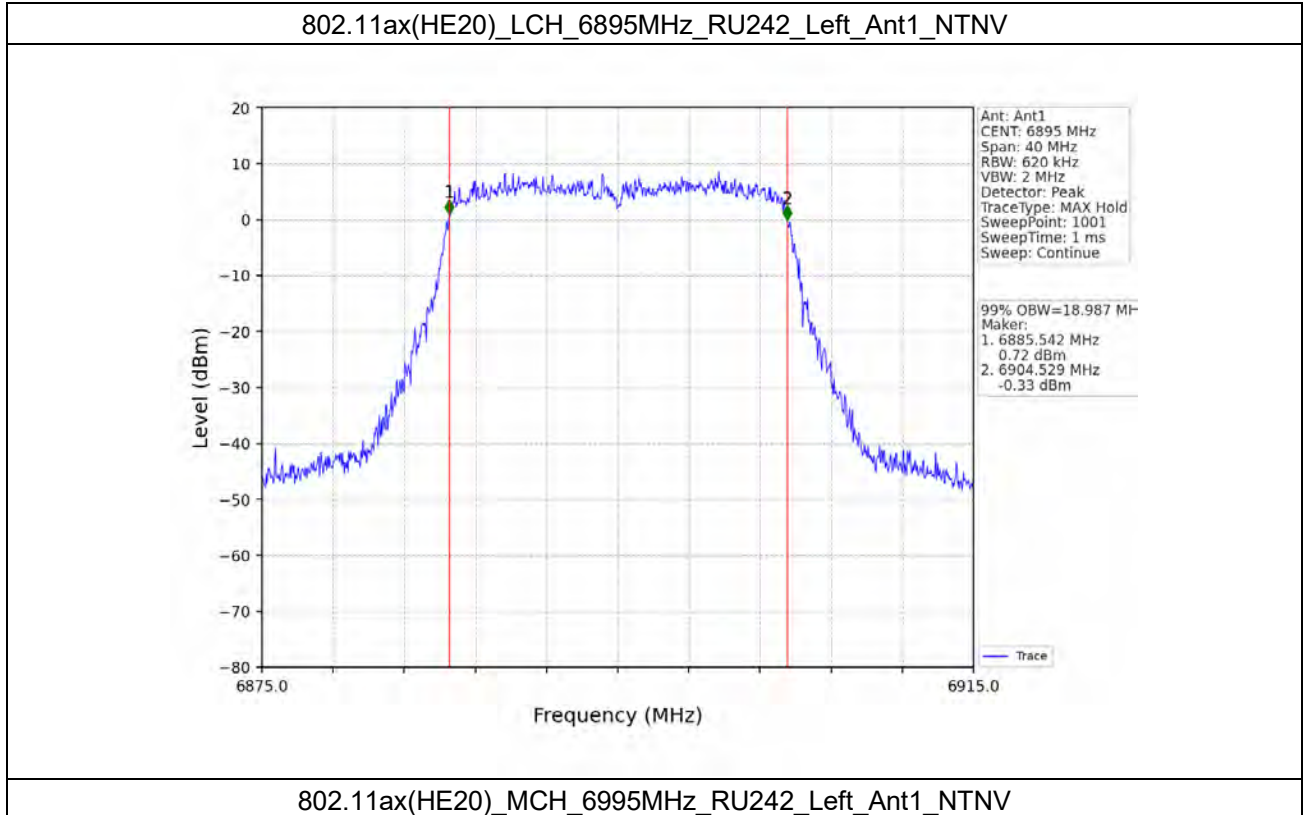

Unless otherwise agreed in writing, this document is issued by the Company subject to its General Conditions of Service printed overleaf, available on request or accessible at <https://www.sgs.com/en/Terms-and-Conditions>. Attention is drawn to the limitation of liability, indemnification and jurisdiction issues defined therein. Any holder of this document is advised that information contained hereon reflects the Company's findings at the time of its intervention only and within the limits of Client's instructions, if any. The Company's sole responsibility is to its Client and this document does not exonerate parties to a transaction from exercising all their rights and obligations under the transaction documents. This document cannot be reproduced except in full, without prior written approval of the Company. Any unauthorized alteration, forgery or falsification of the content or appearance of this document is unlawful and offenders may be prosecuted to the fullest extent of the law. Unless otherwise stated the results shown in this test report refer only to the sample(s) tested and such sample(s) are retained for 30 days only.

Attention: To check the authenticity of testing /inspection report & certificate, please contact us at telephone: (86-755) 8307 1443, or email: CN.Doccheck@sgs.com

SGS-CSTC Standards Technical Services Co., Ltd. Shenzhen Branch Laboratory  
 No.1 Workshop, M-10, Middle Section, Science & Technology Park, Nanshan District, Shenzhen, Guangdong, China 518057 t (86-755) 26012053 f (86-755) 26710594 www.sgs.com.cn  
 中国·广东·深圳市南山区科技园中区M-10栋1号厂房 邮编: 518057 t (86-755) 26012053 f (86-755) 26710594 sgs.china@sgs.com

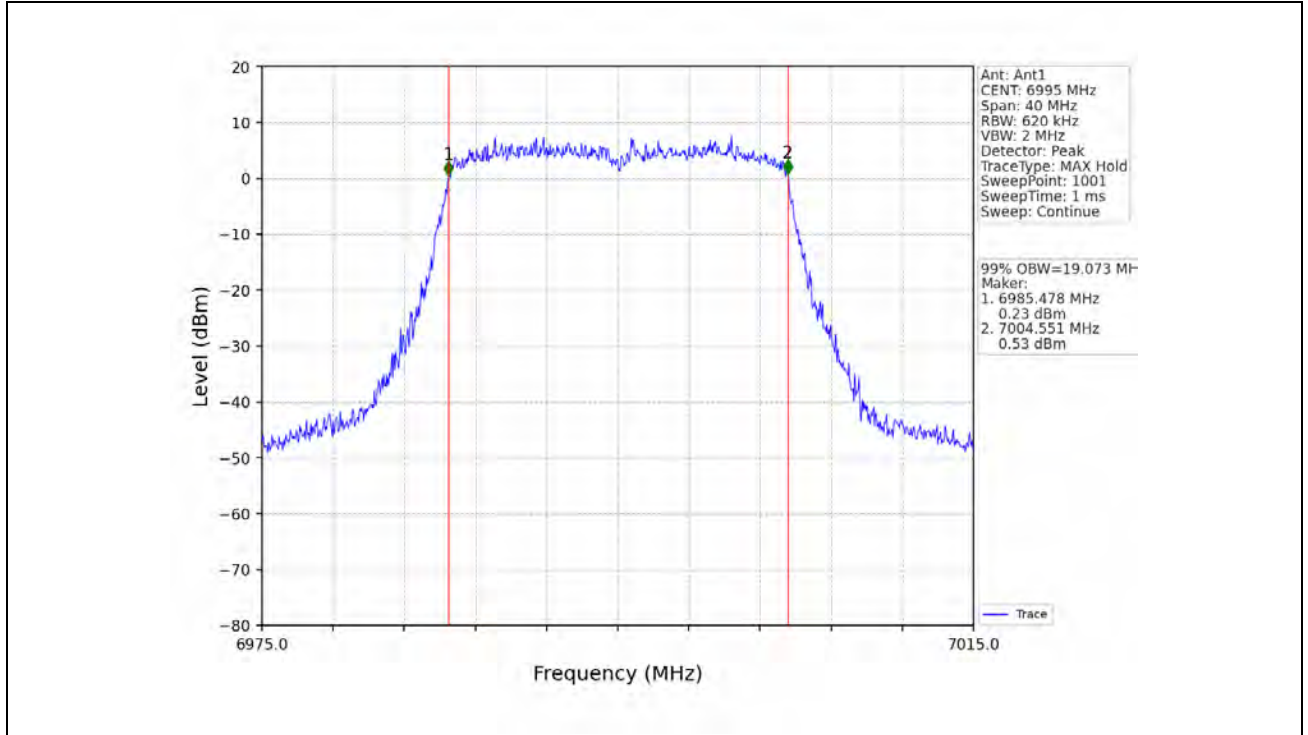

Unless otherwise agreed in writing, this document is issued by the Company subject to its General Conditions of Service printed overleaf, available on request or accessible at <https://www.sgs.com/en/Terms-and-Conditions>. Attention is drawn to the limitation of liability, indemnification and jurisdiction issues defined therein. Any holder of this document is advised that information contained hereon reflects the Company's findings at the time of its intervention only and within the limits of Client's instructions, if any. The Company's sole responsibility is to its Client and this document does not exonerate parties to a transaction from exercising all their rights and obligations under the transaction documents. This document cannot be reproduced except in full, without prior written approval of the Company. Any unauthorized alteration, forgery or falsification of the content or appearance of this document is unlawful and offenders may be prosecuted to the fullest extent of the law. Unless otherwise stated the results shown in this test report refer only to the sample(s) tested and such sample(s) are retained for 30 days only.

Attention: To check the authenticity of testing /inspection report & certificate, please contact us at telephone: (86-755) 8307 1443, or email: [CN.Doccheck@sgs.com](mailto:CN.Doccheck@sgs.com)  
 No.1 Workshop, M-10, Middle Section, Science & Technology Park, Nanshan District, Shenzhen, Guangdong, China 518057 t (86-755) 26012053 f (86-755) 26710594 www.sgsgroup.com.cn  
 中国·广东·深圳市南山区科技园中区M-10栋1号厂房 邮编: 518057 t (86-755) 26012053 f (86-755) 26710594 sgs.china@sgs.com

802.11ax(HE20)\_HCH\_7115MHz\_RU242\_Left\_Ant1\_NTNV

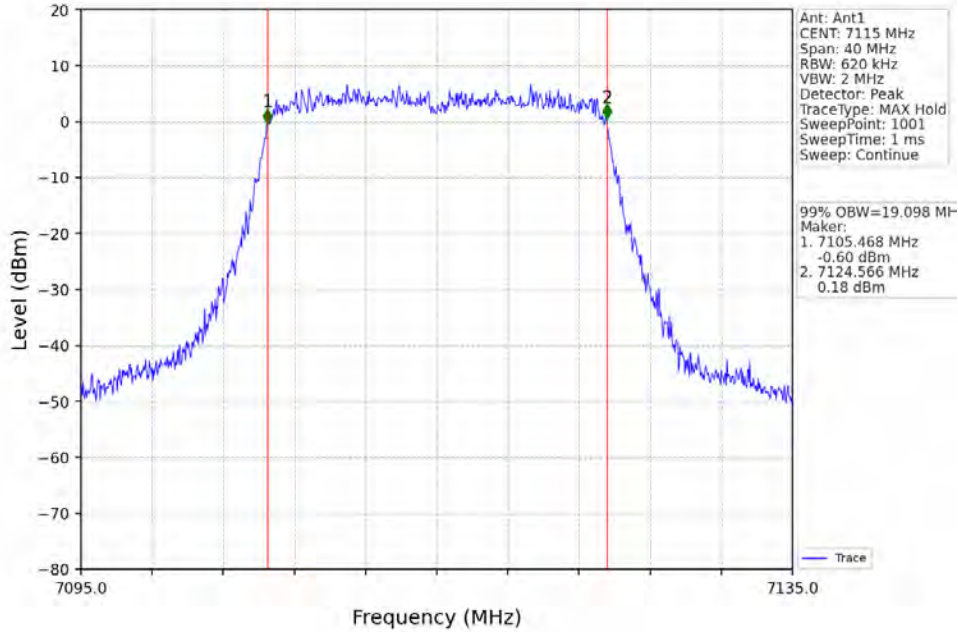

802.11ax(HE40)\_LCH\_6925MHz\_RU484\_Left\_Ant1\_NTNV

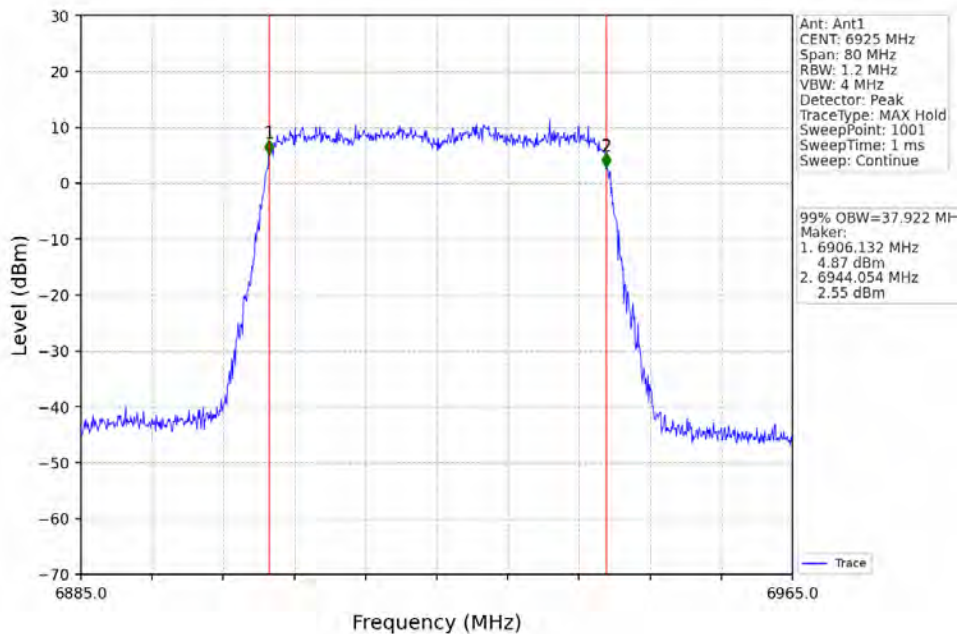

Unless otherwise agreed in writing, this document is issued by the Company subject to its General Conditions of Service printed overleaf, available on request or accessible at <https://www.sgs.com/en/Terms-and-Conditions>. Attention is drawn to the limitation of liability, indemnification and jurisdiction issues defined therein. Any holder of this document is advised that information contained hereon reflects the Company's findings at the time of its intervention only and within the limits of Client's instructions, if any. The Company's sole responsibility is to its Client and this document does not exonerate parties to a transaction from exercising all their rights and obligations under the transaction documents. This document cannot be reproduced except in full, without prior written approval of the Company. Any unauthorized alteration, forgery or falsification of the content or appearance of this document is unlawful and offenders may be prosecuted to the fullest extent of the law. Unless otherwise stated the results shown in this test report refer only to the sample(s) tested and such sample(s) are retained for 30 days only.

Attention: To check the authenticity of testing /inspection report & certificate, please contact us at telephone: (86-755) 8307 1443, or email: CN.Doccheck@sgs.com



802.11ax(HE40)\_MCH\_7005MHz\_RU484\_Left\_Ant1\_NTNV

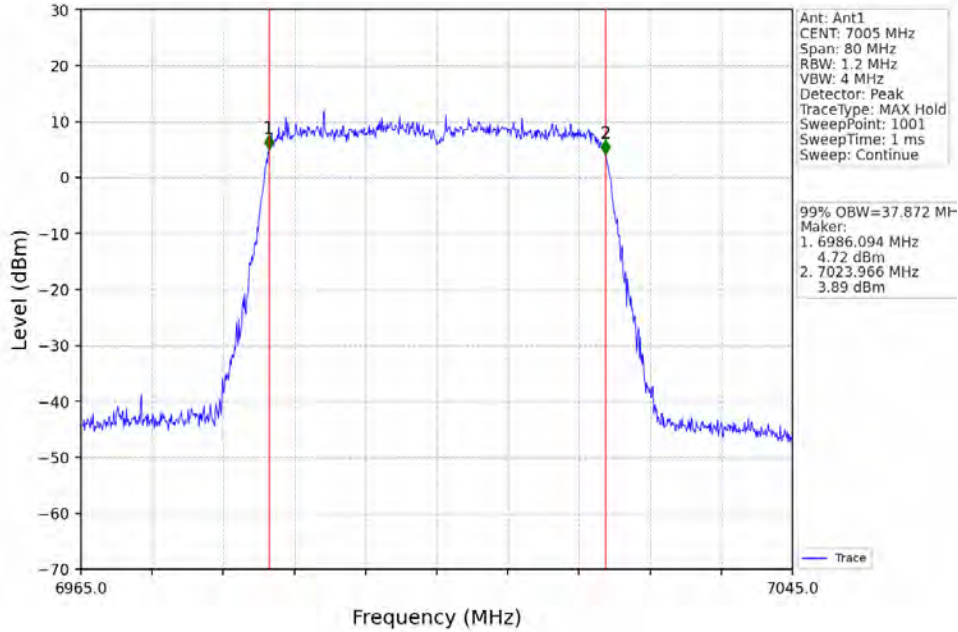

802.11ax(HE40)\_HCH\_7085MHz\_RU484\_Left\_Ant1\_NTNV

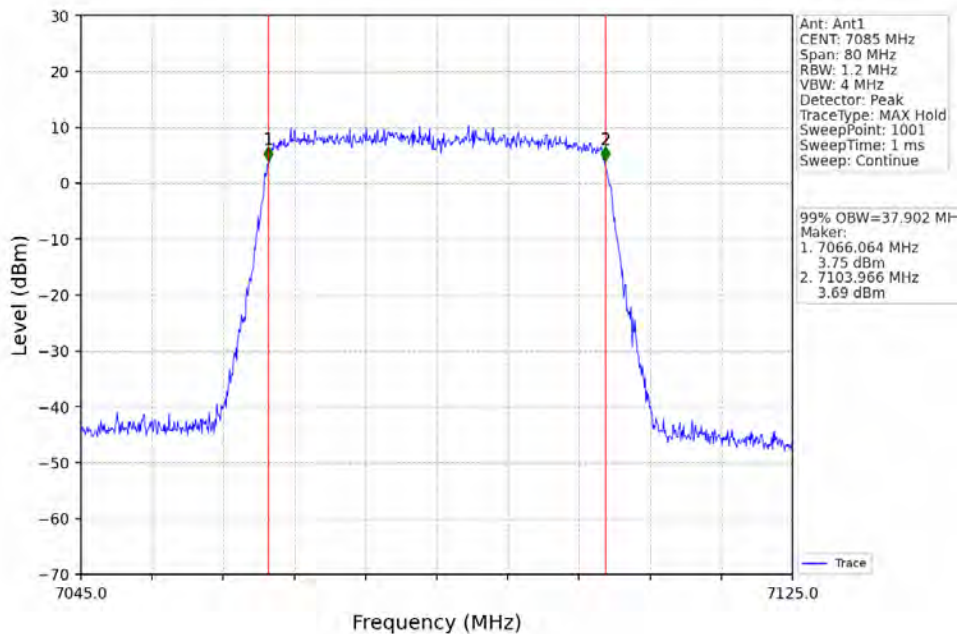

Unless otherwise agreed in writing, this document is issued by the Company subject to its General Conditions of Service printed overleaf, available on request or accessible at <https://www.sgs.com/en/Terms-and-Conditions>. Attention is drawn to the limitation of liability, indemnification and jurisdiction issues defined therein. Any holder of this document is advised that information contained hereon reflects the Company's findings at the time of its intervention only and within the limits of Client's instructions, if any. The Company's sole responsibility is to its Client and this document does not exonerate parties to a transaction from exercising all their rights and obligations under the transaction documents. This document cannot be reproduced except in full, without prior written approval of the Company. Any unauthorized alteration, forgery or falsification of the content or appearance of this document is unlawful and offenders may be prosecuted to the fullest extent of the law. Unless otherwise stated the results shown in this test report refer only to the sample(s) tested and such sample(s) are retained for 30 days only.

Attention: To check the authenticity of testing /inspection report & certificate, please contact us at telephone: (86-755) 8307 1443, or email: CN.Doccheck@sgs.com

802.11ax(HE80)\_LCH\_6945MHz\_RU996\_Left\_Ant1\_NTNV

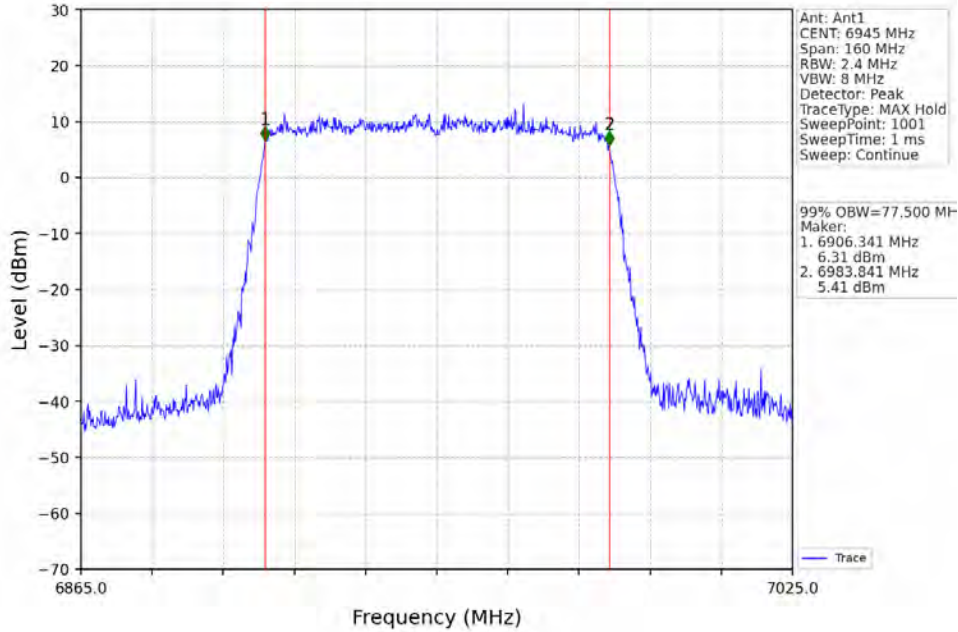

802.11ax(HE80)\_HCH\_7025MHz\_RU996\_Left\_Ant1\_NTNV

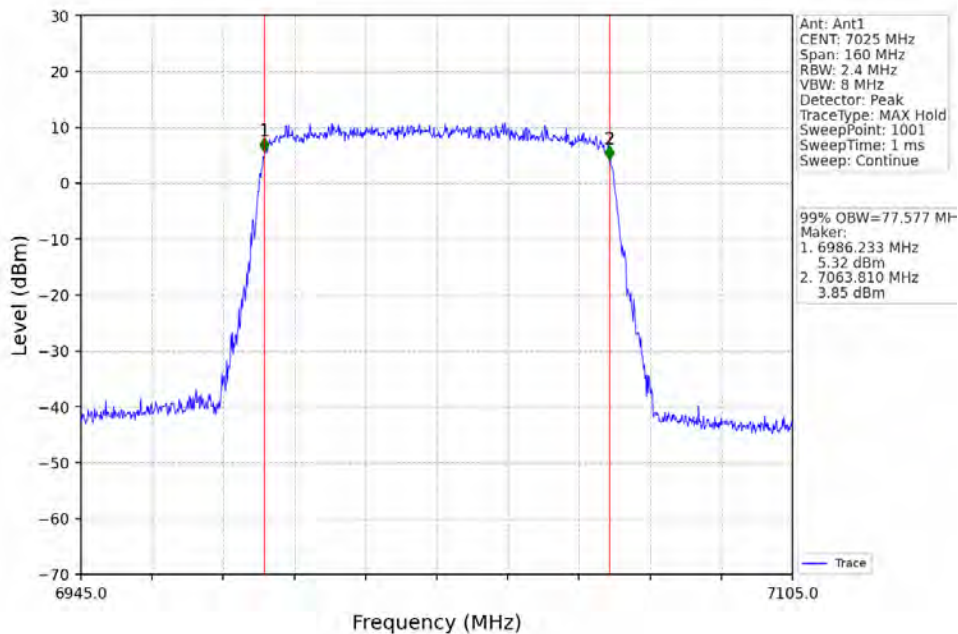

Unless otherwise agreed in writing, this document is issued by the Company subject to its General Conditions of Service printed overleaf, available on request or accessible at <https://www.sgs.com/en/Terms-and-Conditions>. Attention is drawn to the limitation of liability, indemnification and jurisdiction issues defined therein. Any holder of this document is advised that information contained hereon reflects the Company's findings at the time of its intervention only and within the limits of Client's instructions, if any. The Company's sole responsibility is to its Client and this document does not exonerate parties to a transaction from exercising all their rights and obligations under the transaction documents. This document cannot be reproduced except in full, without prior written approval of the Company. Any unauthorized alteration, forgery or falsification of the content or appearance of this document is unlawful and offenders may be prosecuted to the fullest extent of the law. Unless otherwise stated the results shown in this test report refer only to the sample(s) tested and such sample(s) are retained for 30 days only.

Attention: To check the authenticity of testing /inspection report & certificate, please contact us at telephone: (86-755) 8307 1443, or email: CN.Doccheck@sgs.com

802.11ax(HE160)\_MCH\_6985MHz\_2xRU996\_Left\_Ant1\_NTNV

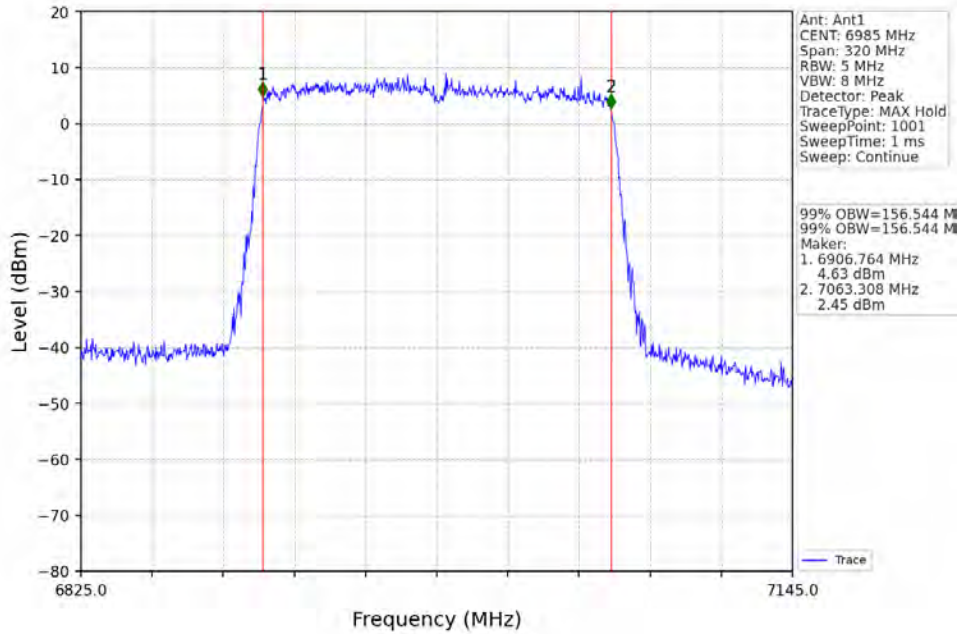

Unless otherwise agreed in writing, this document is issued by the Company subject to its General Conditions of Service printed overleaf, available on request or accessible at <https://www.sgs.com/en/Terms-and-Conditions>. Attention is drawn to the limitation of liability, indemnification and jurisdiction issues defined therein. Any holder of this document is advised that information contained hereon reflects the Company's findings at the time of its intervention only and within the limits of Client's instructions, if any. The Company's sole responsibility is to its Client and this document does not exonerate parties to a transaction from exercising all their rights and obligations under the transaction documents. This document cannot be reproduced except in full, without prior written approval of the Company. Any unauthorized alteration, forgery or falsification of the content or appearance of this document is unlawful and offenders may be prosecuted to the fullest extent of the law. Unless otherwise stated the results shown in this test report refer only to the sample(s) tested and such sample(s) are retained for 30 days only.

Attention: To check the authenticity of testing /inspection report & certificate, please contact us at telephone: (86-755) 8307 1443, or email: CN.Doccheck@sgs.com



2.8 26dB BW

2.8.1 Test Result

ENV	Mode	TX Type	Frequency (MHz)	RU	RU Pos	ANT	26dB Bandwidth (MHz)		Verdict
							Result	Limit	
NTNV	802.11ax (HE20)	MIMO	6895	RU242	Left	1	20.874	For Report Purpose	Pass
			6995	RU242	Left	1	20.823	For Report Purpose	Pass
			7115	RU242	Left	1	20.621	For Report Purpose	Pass
	802.11ax (HE40)	MIMO	6925	RU484	Left	1	40.135	For Report Purpose	Pass
			7005	RU484	Left	1	40.613	For Report Purpose	Pass
			7085	RU484	Left	1	40.565	For Report Purpose	Pass
	802.11ax (HE80)	MIMO	6945	RU996	Left	1	81.632	For Report Purpose	Pass
			7025	RU996	Left	1	82.063	For Report Purpose	Pass
	802.11ax (HE160)	MIMO	6985	2xRU996	Left	1	165.529	For Report Purpose	Pass



Unless otherwise agreed in writing, this document is issued by the Company subject to its General Conditions of Service printed overleaf, available on request or accessible at <https://www.sgs.com/en/Terms-and-Conditions>. Attention is drawn to the limitation of liability, indemnification and jurisdiction issues defined therein. Any holder of this document is advised that information contained hereon reflects the Company's findings at the time of its intervention only and within the limits of Client's instructions, if any. The Company's sole responsibility is to its Client and this document does not exonerate parties to a transaction from exercising all their rights and obligations under the transaction documents. This document cannot be reproduced except in full, without prior written approval of the Company. Any unauthorized alteration, forgery or falsification of the content or appearance of this document is unlawful and offenders may be prosecuted to the fullest extent of the law. Unless otherwise stated the results shown in this test report refer only to the sample(s) tested and such sample(s) are retained for 30 days only.

Attention: To check the authenticity of testing /inspection report & certificate, please contact us at telephone: (86-755) 8307 1443, or email: [CN.Doccheck@sgs.com](mailto:CN.Doccheck@sgs.com)  
 No.1 Workshop, M-10, Middle Section, Science & Technology Park, Nanshan District, Shenzhen, Guangdong, China 518057 t (86-755) 26012053 f (86-755) 26710594 www.sgsgroup.com.cn  
 中国·广东·深圳市南山区科技园中区M-10栋1号厂房 邮编: 518057 t (86-755) 26012053 f (86-755) 26710594 sgs.china@sgs.com

2.8.2 Test Graph

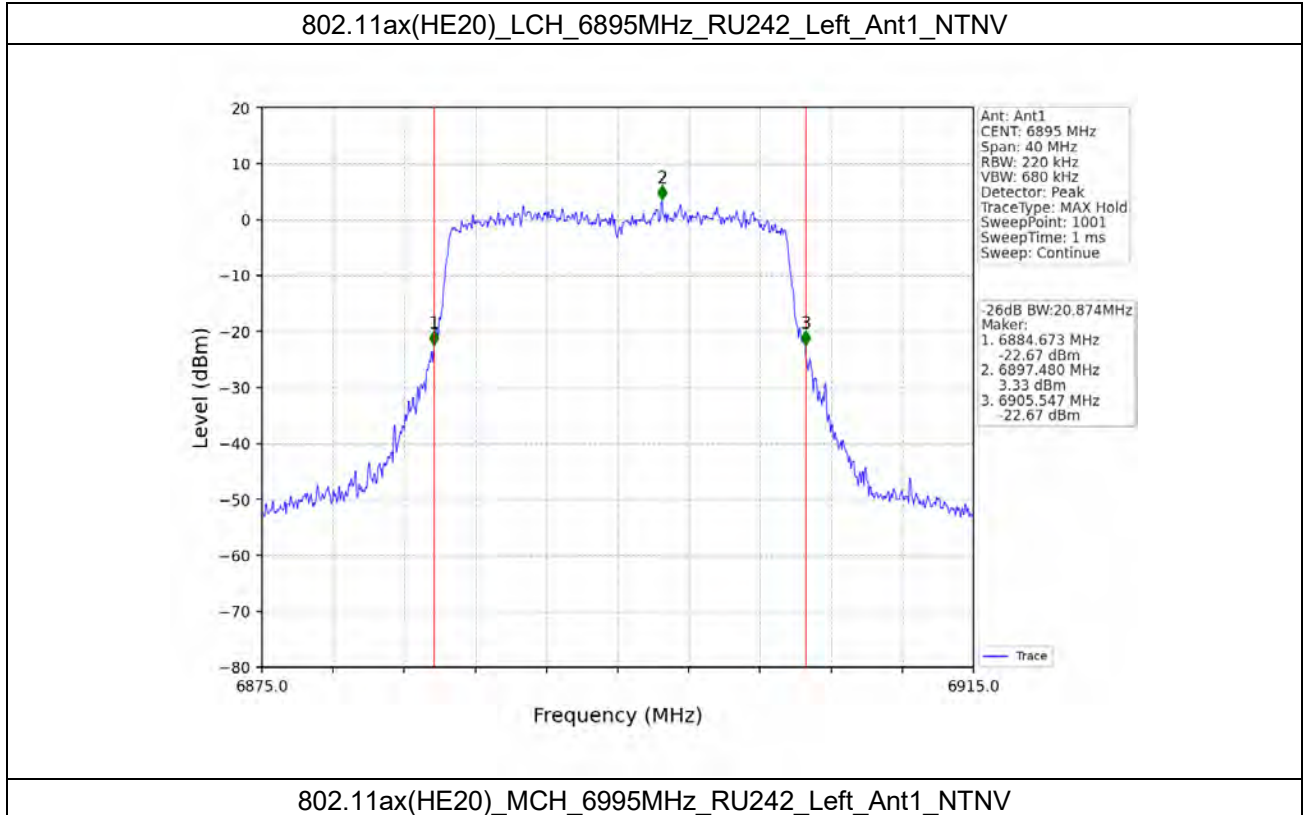

Unless otherwise agreed in writing, this document is issued by the Company subject to its General Conditions of Service printed overleaf, available on request or accessible at <https://www.sgs.com/en/Terms-and-Conditions>. Attention is drawn to the limitation of liability, indemnification and jurisdiction issues defined therein. Any holder of this document is advised that information contained hereon reflects the Company's findings at the time of its intervention only and within the limits of Client's instructions, if any. The Company's sole responsibility is to its Client and this document does not exonerate parties to a transaction from exercising all their rights and obligations under the transaction documents. This document cannot be reproduced except in full, without prior written approval of the Company. Any unauthorized alteration, forgery or falsification of the content or appearance of this document is unlawful and offenders may be prosecuted to the fullest extent of the law. Unless otherwise stated the results shown in this test report refer only to the sample(s) tested and such sample(s) are retained for 30 days only.

Attention: To check the authenticity of testing /inspection report & certificate, please contact us at telephone: (86-755) 8307 1443, or email: CN.Doccheck@sgs.com

SGS-CSTC Standards Technical Services Co., Ltd. Shenzhen Branch  
 No.1 Workshop, M-10, Middle Section, Science & Technology Park, Nanshan District, Shenzhen, Guangdong, China 518057 t (86-755) 26012053 f (86-755) 26710594 www.sgs.com.cn  
 中国·广东·深圳市南山区科技园中区M-10栋1号厂房 邮编: 518057 t (86-755) 26012053 f (86-755) 26710594 sgs.china@sgs.com

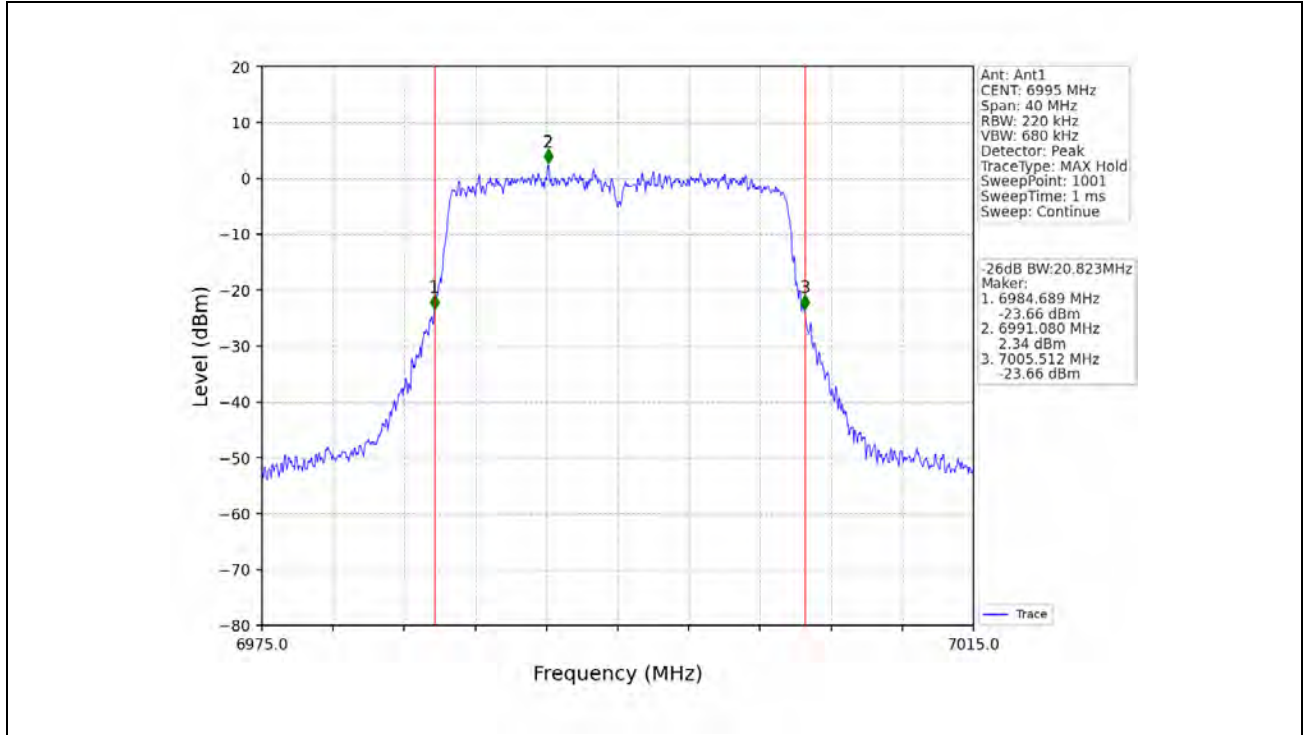

Unless otherwise agreed in writing, this document is issued by the Company subject to its General Conditions of Service printed overleaf, available on request or accessible at <https://www.sgs.com/en/Terms-and-Conditions>. Attention is drawn to the limitation of liability, indemnification and jurisdiction issues defined therein. Any holder of this document is advised that information contained hereon reflects the Company's findings at the time of its intervention only and within the limits of Client's instructions, if any. The Company's sole responsibility is to its Client and this document does not exonerate parties to a transaction from exercising all their rights and obligations under the transaction documents. This document cannot be reproduced except in full, without prior written approval of the Company. Any unauthorized alteration, forgery or falsification of the content or appearance of this document is unlawful and offenders may be prosecuted to the fullest extent of the law. Unless otherwise stated the results shown in this test report refer only to the sample(s) tested and such sample(s) are retained for 30 days only.



802.11ax(HE20)\_HCH\_7115MHz\_RU242\_Left\_Ant1\_NTNV

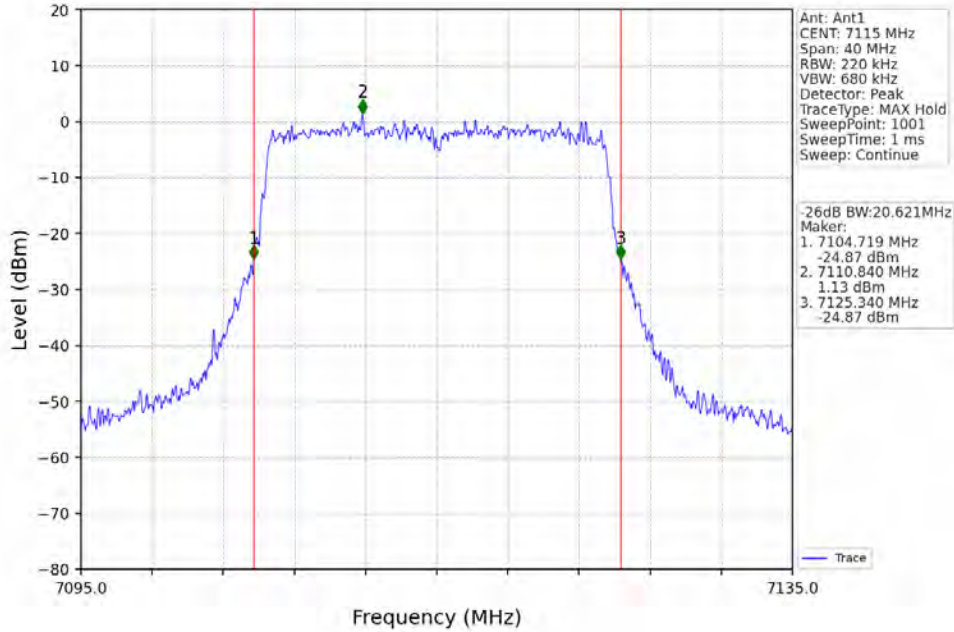

802.11ax(HE40)\_LCH\_6925MHz\_RU484\_Left\_Ant1\_NTNV

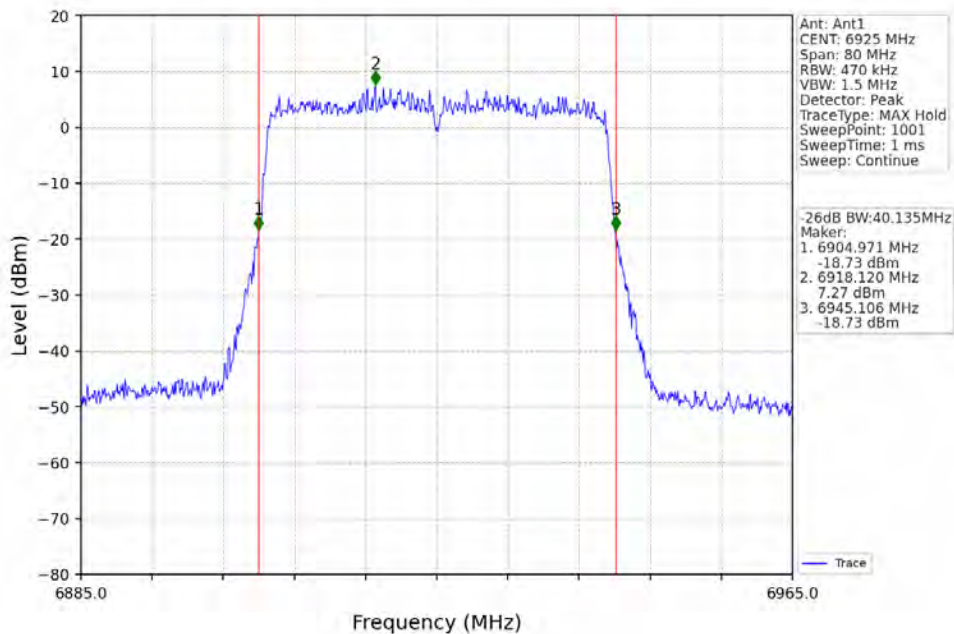

Unless otherwise agreed in writing, this document is issued by the Company subject to its General Conditions of Service printed overleaf, available on request or accessible at <https://www.sgs.com/en/Terms-and-Conditions>. Attention is drawn to the limitation of liability, indemnification and jurisdiction issues defined therein. Any holder of this document is advised that information contained hereon reflects the Company's findings at the time of its intervention only and within the limits of Client's instructions, if any. The Company's sole responsibility is to its Client and this document does not exonerate parties to a transaction from exercising all their rights and obligations under the transaction documents. This document cannot be reproduced except in full, without prior written approval of the Company. Any unauthorized alteration, forgery or falsification of the content or appearance of this document is unlawful and offenders may be prosecuted to the fullest extent of the law. Unless otherwise stated the results shown in this test report refer only to the sample(s) tested and such sample(s) are retained for 30 days only.

Attention: To check the authenticity of testing /inspection report & certificate, please contact us at telephone: (86-755) 8307 1443, or email: CN.Doccheck@sgs.com

### 802.11ax(HE40)\_MCH\_7005MHz\_RU484\_Left\_Ant1\_NTNV

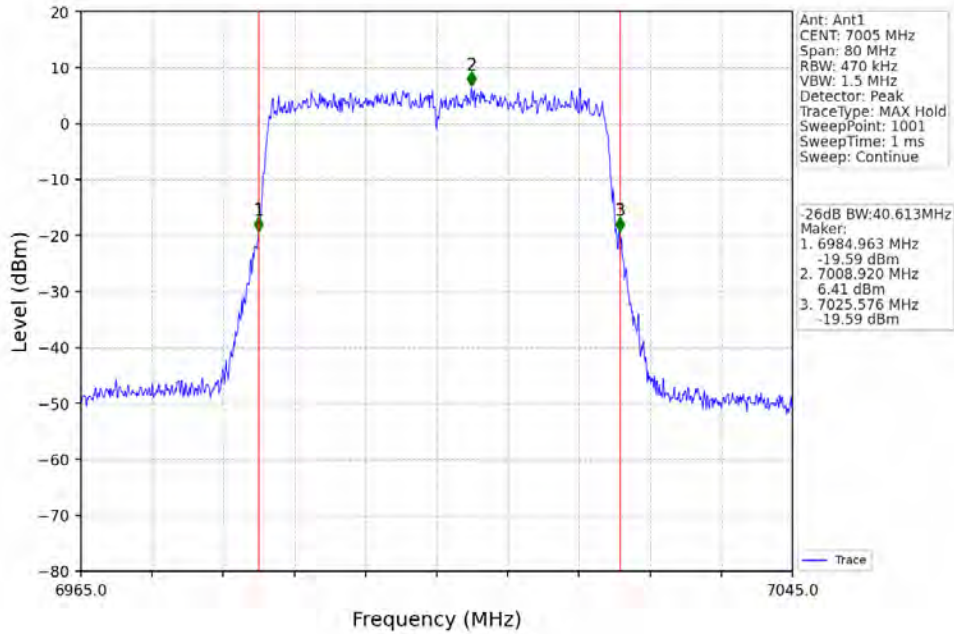

### 802.11ax(HE40)\_HCH\_7085MHz\_RU484\_Left\_Ant1\_NTNV

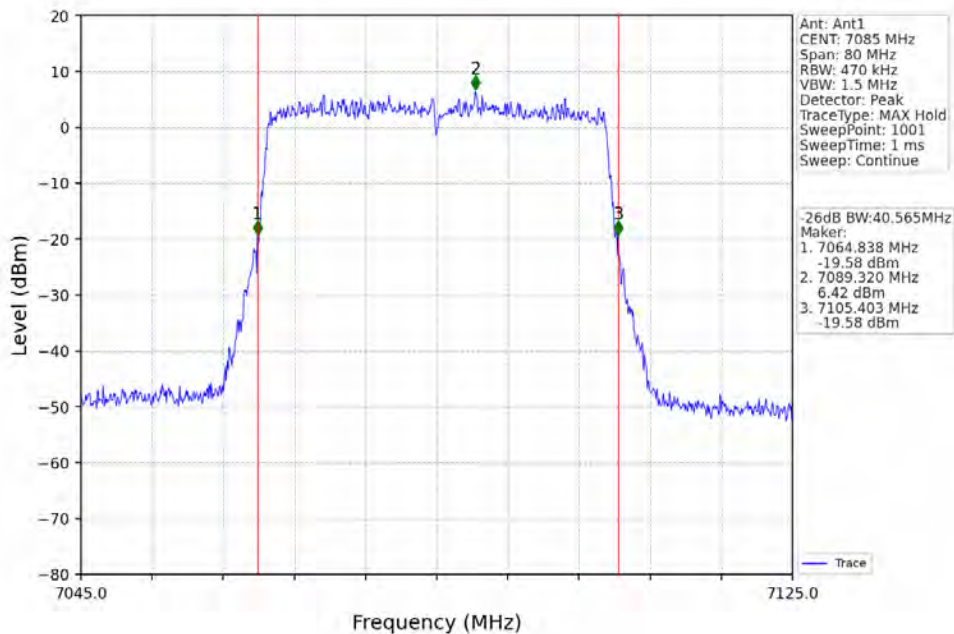

Unless otherwise agreed in writing, this document is issued by the Company subject to its General Conditions of Service printed overleaf, available on request or accessible at <https://www.sgs.com/en/Terms-and-Conditions>. Attention is drawn to the limitation of liability, indemnification and jurisdiction issues defined therein. Any holder of this document is advised that information contained hereon reflects the Company's findings at the time of its intervention only and within the limits of Client's instructions, if any. The Company's sole responsibility is to its Client and this document does not exonerate parties to a transaction from exercising all their rights and obligations under the transaction documents. This document cannot be reproduced except in full, without prior written approval of the Company. Any unauthorized alteration, forgery or falsification of the content or appearance of this document is unlawful and offenders may be prosecuted to the fullest extent of the law. Unless otherwise stated the results shown in this test report refer only to the sample(s) tested and such sample(s) are retained for 30 days only.



802.11ax(HE80)\_LCH\_6945MHz\_RU996\_Left\_Ant1\_NTNV

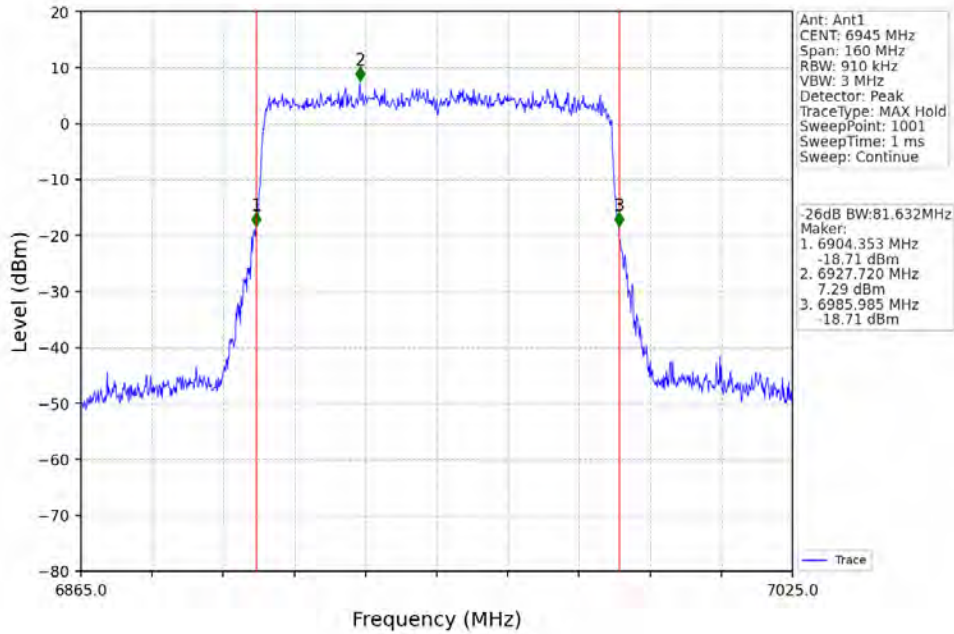

802.11ax(HE80)\_HCH\_7025MHz\_RU996\_Left\_Ant1\_NTNV

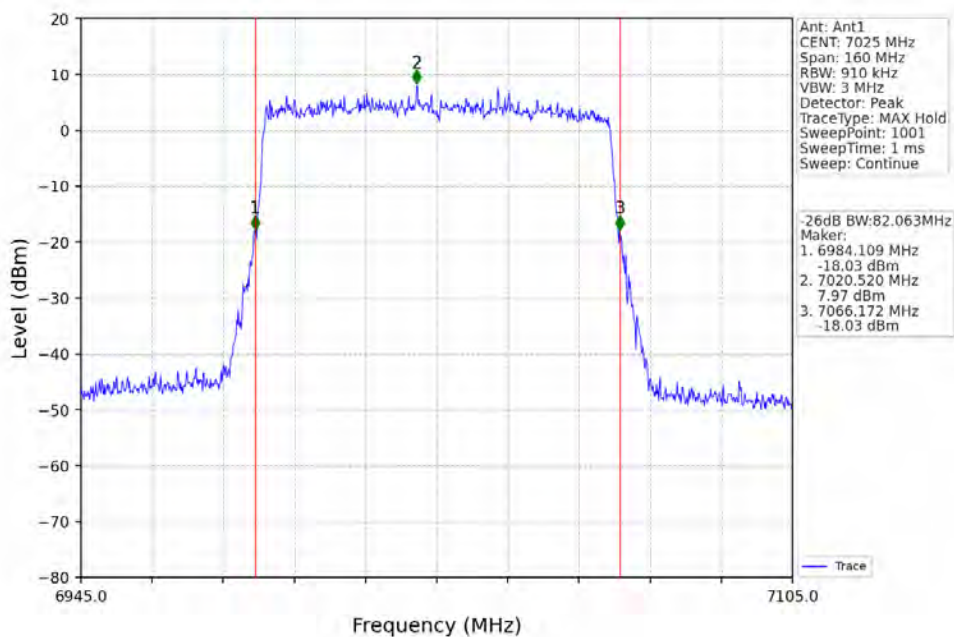

Unless otherwise agreed in writing, this document is issued by the Company subject to its General Conditions of Service printed overleaf, available on request or accessible at <https://www.sgs.com/en/Terms-and-Conditions>. Attention is drawn to the limitation of liability, indemnification and jurisdiction issues defined therein. Any holder of this document is advised that information contained hereon reflects the Company's findings at the time of its intervention only and within the limits of Client's instructions, if any. The Company's sole responsibility is to its Client and this document does not exonerate parties to a transaction from exercising all their rights and obligations under the transaction documents. This document cannot be reproduced except in full, without prior written approval of the Company. Any unauthorized alteration, forgery or falsification of the content or appearance of this document is unlawful and offenders may be prosecuted to the fullest extent of the law. Unless otherwise stated the results shown in this test report refer only to the sample(s) tested and such sample(s) are retained for 30 days only.

Attention: To check the authenticity of testing /inspection report & certificate, please contact us at telephone: (86-755) 8307 1443, or email: CN.Doccheck@sgs.com



SGS-CSTC Standards Technical Services Co., Ltd.  
Shenzhen Branch

No.1 Workshop, M-10, Middle Section, Science & Technology Park, Nanshan District, Shenzhen, Guangdong, China 518057 t (86-755) 26012053 f (86-755) 26710594 www.sgs.com.cn  
中国·广东·深圳市南山区科技园中区M-10栋1号厂房 邮编: 518057 t (86-755) 26012053 f (86-755) 26710594 sgs.china@sgs.com



802.11ax(HE160)\_MCH\_6985MHz\_2xRU996\_Left\_Ant1\_NTNV

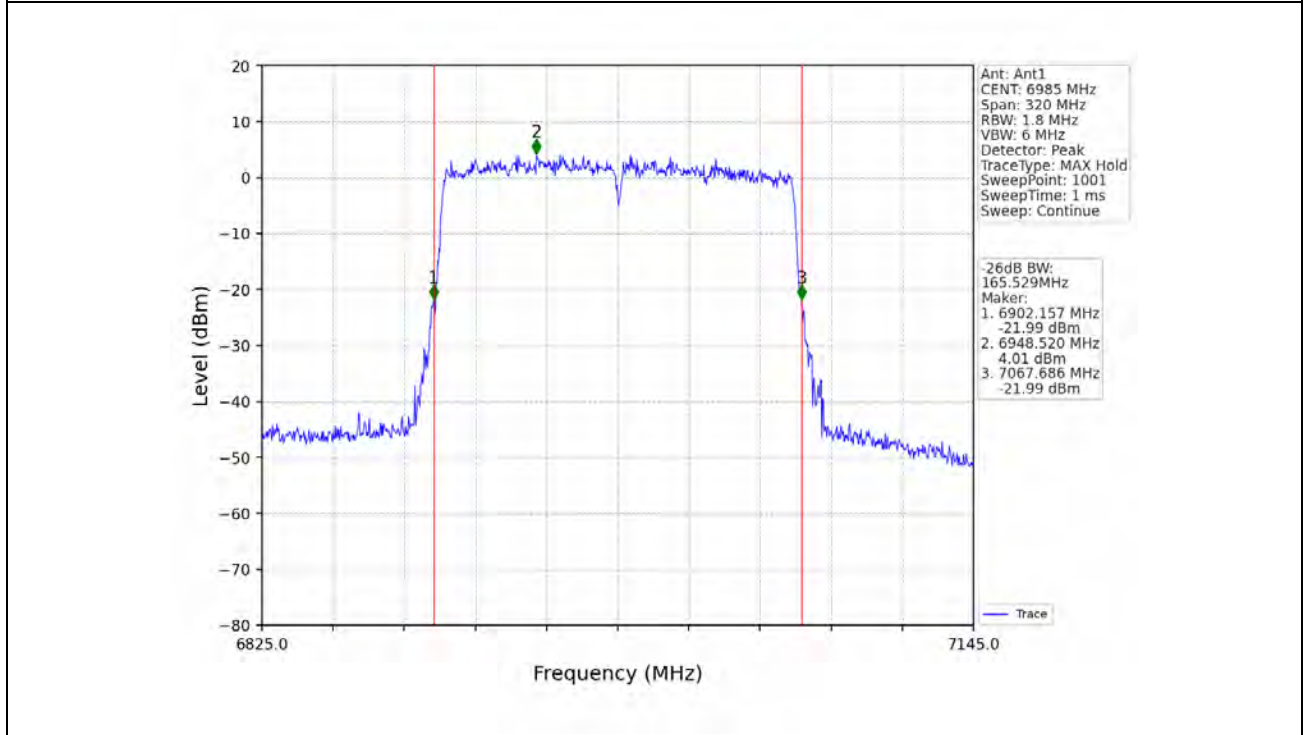

Unless otherwise agreed in writing, this document is issued by the Company subject to its General Conditions of Service printed overleaf, available on request or accessible at <https://www.sgs.com/en/Terms-and-Conditions>. Attention is drawn to the limitation of liability, indemnification and jurisdiction issues defined therein. Any holder of this document is advised that information contained hereon reflects the Company's findings at the time of its intervention only and within the limits of Client's instructions, if any. The Company's sole responsibility is to its Client and this document does not exonerate parties to a transaction from exercising all their rights and obligations under the transaction documents. This document cannot be reproduced except in full, without prior written approval of the Company. Any unauthorized alteration, forgery or falsification of the content or appearance of this document is unlawful and offenders may be prosecuted to the fullest extent of the law. Unless otherwise stated the results shown in this test report refer only to the sample(s) tested and such sample(s) are retained for 30 days only.

Attention: To check the authenticity of testing /inspection report & certificate, please contact us at telephone: (86-755) 8307 1443, or email: CN.Doccheck@sgs.com

No.1 Workshop, M-10, Middle Section, Science & Technology Park, Nanshan District, Shenzhen, Guangdong, China 518057 t (86-755) 26012053 f (86-755) 26710594 www.sgs.com.cn  
 中国·广东·深圳市南山区科技园中区M-10栋1号厂房 邮编: 518057 t (86-755) 26012053 f (86-755) 26710594 sgs.china@sgs.com