

FGM842D-P Series

Hardware Design

Wi-Fi&Bluetooth Module Series

Version: 1.0.0

Date: 2023-10-17

Status: Preliminary



At Quectel, our aim is to provide timely and comprehensive services to our customers. If you require any assistance, please contact our headquarters:

Quectel Wireless Solutions Co., Ltd.

Building 5, Shanghai Business Park Phase III (Area B), No.1016 Tianlin Road, Minhang District, Shanghai 200233, China

Tel: +86 21 5108 6236

Email: info@quectel.com

Or our local offices. For more information, please visit:

<http://www.quectel.com/support/sales.htm>.

For technical support, or to report documentation errors, please visit:

<http://www.quectel.com/support/technical.htm>.

Or email us at: support@quectel.com.

Legal Notices

We offer information as a service to you. The provided information is based on your requirements and we make every effort to ensure its quality. You agree that you are responsible for using independent analysis and evaluation in designing intended products, and we provide reference designs for illustrative purposes only. Before using any hardware, software or service guided by this document, please read this notice carefully. Even though we employ commercially reasonable efforts to provide the best possible experience, you hereby acknowledge and agree that this document and related services hereunder are provided to you on an “as available” basis. We may revise or restate this document from time to time at our sole discretion without any prior notice to you.

Use and Disclosure Restrictions

License Agreements

Documents and information provided by us shall be kept confidential, unless specific permission is granted. They shall not be accessed or used for any purpose except as expressly provided herein.

Copyright

Our and third-party products hereunder may contain copyrighted material. Such copyrighted material shall not be copied, reproduced, distributed, merged, published, translated, or modified without prior written consent. We and the third party have exclusive rights over copyrighted material. No license shall be granted or conveyed under any patents, copyrights, trademarks, or service mark rights. To avoid ambiguities, purchasing in any form cannot be deemed as granting a license other than the normal non-exclusive, royalty-free license to use the material. We reserve the right to take legal action for noncompliance with abovementioned requirements, unauthorized use, or other illegal or malicious use of the material.

Trademarks

Except as otherwise set forth herein, nothing in this document shall be construed as conferring any rights to use any trademark, trade name or name, abbreviation, or counterfeit product thereof owned by Quectel or any third party in advertising, publicity, or other aspects.

Third-Party Rights

This document may refer to hardware, software and/or documentation owned by one or more third parties (“third-party materials”). Use of such third-party materials shall be governed by all restrictions and obligations applicable thereto.

We make no warranty or representation, either express or implied, regarding the third-party materials, including but not limited to any implied or statutory, warranties of merchantability or fitness for a particular purpose, quiet enjoyment, system integration, information accuracy, and non-infringement of any third-party intellectual property rights with regard to the licensed technology or use thereof. Nothing herein constitutes a representation or warranty by us to either develop, enhance, modify, distribute, market, sell, offer for sale, or otherwise maintain production of any our products or any other hardware, software, device, tool, information, or product. We moreover disclaim any and all warranties arising from the course of dealing or usage of trade.

Privacy Policy

To implement module functionality, certain device data are uploaded to Quectel’s or third-party’s servers, including carriers, chipset suppliers or customer-designated servers. Quectel, strictly abiding by the relevant laws and regulations, shall retain, use, disclose or otherwise process relevant data for the purpose of performing the service only or as permitted by applicable laws. Before data interaction with third parties, please be informed of their privacy and data security policy.

Disclaimer

- a) We acknowledge no liability for any injury or damage arising from the reliance upon the information.
- b) We shall bear no liability resulting from any inaccuracies or omissions, or from the use of the information contained herein.
- c) While we have made every effort to ensure that the functions and features under development are free from errors, it is possible that they could contain errors, inaccuracies, and omissions. Unless otherwise provided by valid agreement, we make no warranties of any kind, either implied or express, and exclude all liability for any loss or damage suffered in connection with the use of features and functions under development, to the maximum extent permitted by law, regardless of whether such loss or damage may have been foreseeable.
- d) We are not responsible for the accessibility, safety, accuracy, availability, legality, or completeness of information, advertising, commercial offers, products, services, and materials on third-party websites and third-party resources.

Copyright © Quectel Wireless Solutions Co., Ltd. 2023. All rights reserved.

Safety Information

The following safety precautions must be observed during all phases of operation, such as usage, service or repair of any terminal or mobile incorporating the module. Manufacturers of the terminal should notify users and operating personnel of the following safety information by incorporating these guidelines into all manuals of the product. Otherwise, Quectel assumes no liability for customers' failure to comply with these precautions.



Full attention must be paid to driving at all times in order to reduce the risk of an accident. Using a mobile while driving (even with a handsfree kit) causes distraction and can lead to an accident. Please comply with laws and regulations restricting the use of wireless devices while driving.



Switch off the terminal or mobile before boarding an aircraft. The operation of wireless appliances in an aircraft is forbidden to prevent interference with communication systems. If there is an Airplane Mode, it should be enabled prior to boarding an aircraft. Please consult the airline staff for more restrictions on the use of wireless devices on an aircraft.



Wireless devices may cause interference on sensitive medical equipment, so please be aware of the restrictions on the use of wireless devices when in hospitals, clinics or other healthcare facilities.



Terminals or mobiles operating over radio signal and cellular network cannot be guaranteed to connect in certain conditions, such as when the mobile bill is unpaid or the (U)SIM card is invalid. When emergency help is needed in such conditions, use emergency call if the device supports it. In order to make or receive a call, the terminal or mobile must be switched on in a service area with adequate cellular signal strength. In an emergency, the device with emergency call function cannot be used as the only contact method considering network connection cannot be guaranteed under all circumstances.



The terminal or mobile contains a transceiver. When it is ON, it receives and transmits radio frequency signals. RF interference can occur if it is used close to TV sets, radios, computers or other electric equipment.



In locations with explosive or potentially explosive atmospheres, obey all posted signs and turn off wireless devices such as mobile phone or other terminals. Areas with explosive or potentially explosive atmospheres include fueling areas, below decks on boats, fuel or chemical transfer or storage facilities, and areas where the air contains chemicals or particles such as grain, dust or metal powders.

About the Document

Revision History

Version	Date	Author	Description
-	2023-10-16	Wain ZHAO/Neil CHENG	Creation of the document
1.0.0	2023-10-17	Wain ZHAO/Neil CHENG	Preliminary

Contents

Safety Information	3
About the Document	4
Contents	5
Table Index	7
Figure Index	8
1 Introduction	9
1.1. Special Mark	10
2 Product Overview	11
2.1. Key Features.....	12
3 Application Interfaces	13
3.1. Pin Assignment	13
3.2. Pin Description.....	14
3.3. GPIO Multiplexing	16
3.4. Application Interfaces.....	17
3.4.1. UARTs	17
3.4.2. SPI	18
3.4.3. I2C Interfaces	20
3.4.4. PWM Interfaces	20
3.4.5. ADC Interfaces	21
4 Operating Characteristics	22
4.1. Power Supply.....	22
4.1.1. Reference Design for Power Supply	22
4.2. Turn On	23
4.3. Reset.....	24
5 RF Performances	26
5.1. Wi-Fi Performances	26
5.2. Bluetooth Performances	27
5.3. Antenna/Antenna Interfaces	28
5.3.1. FGM842D-P PCB Antenna.....	28
6 Electrical Characteristics & Reliability	30
6.1. Absolute Maximum Ratings	30
6.2. Power Supply Ratings.....	30
6.3. Power Consumption.....	31
6.3.1. Wi-Fi Power Consumption.....	31
6.3.2. Bluetooth Power Consumption.....	31
6.4. Digital I/O Characteristics	32

6.5. ESD Protection	32
7 Mechanical Information	33
7.1. Mechanical Dimensions	33
7.2. Recommended Footprint	34
7.3. Top and Bottom Views	35
8 Storage, Manufacturing & Packaging.....	36
8.1. Storage Conditions	36
8.2. Manufacturing and Soldering.....	37
8.3. Packaging Specification.....	39
8.3.1. Carrier Tape.....	39
8.3.2. Plastic Reel.....	40
8.3.3. Mounting Direction.....	40
8.3.4. Packaging Process.....	41
9 Appendix References.....	42

Table Index

Table 1 : Special Mark.....	10
Table 2 : Basic Information	11
Table 3 : Key Features.....	12
Table 4 : Parameter Description	14
Table 5 : Pin Description	14
Table 6 : GPIO Multiplexing	16
Table 7 : Pin Definition of UARTs	17
Table 8 : Pin Definition of SPI	19
Table 9 : Pin Definition of I2C Interfaces	20
Table 10 : Pin Definition of PWM Interfaces	20
Table 11 : Pin Definition of ADC Interfaces	21
Table 12 : ADC Features	21
Table 13 : Pin Definition of Power Supply and GND Pins	22
Table 14 : Pin Definition of CHIP_EN	23
Table 15 : Wi-Fi Performances	26
Table 16 : Bluetooth Performances	27
Table 19 : PCB Antenna Specifications.....	28
Table 21 : Absolute Maximum Ratings (Unit: V).....	30
Table 22 : Module Power Supply Ratings (Unit: V)	30
Table 23 : Power Consumption in Non-signaling Mode (Unit: mA)	31
Table 24 : Power Consumption in Non-signaling Mode (Unit: mA)	31
Table 25 : VBAT I/O Requirements (Unit: V)	32
Table 26 : ESD Characteristics (Unit: kV).....	32
Table 27 : Recommended Thermal Profile Parameters	38
Table 28 : FGM842D Carrier Tape Dimension Table (Unit: mm).....	39
Table 28 : FGM842D-P Carrier Tape Dimension Table (Unit: mm)	39
Table 29 : Plastic Reel Dimension Table (Unit: mm)	40
Table 30 : Reference Documents	42
Table 31 : Terms and Abbreviations	42

Figure Index

Figure 3 :FGM842D-P Pin Assignment (Top View)	13
Figure 4 : UART1 Connection	18
Figure 5 : UART2 Reference Design	18
Figure 6 : SPI Connection (Master Mode)	19
Figure 6 : SPI Connection (Slave Mode)	19
Figure 7 : Reference Circuit of Power Supply.....	23
Figure 8 : Turn-on Timing.....	23
Figure 9 : Reference Circuit of CHIP_EN by Using A Driving Circuit	24
Figure 10 : Reference Circuit of RESET with A Button.....	24
Figure 11 : Reset Timing.....	25
Figure 18 : Prohibited Area for Routing (Bottom Side)	29
Figure 26 :FGM842D-P Top and Side Dimensions	33
Figure 27 :FGM842D-P Bottom Dimensions (Bottom View)	34
Figure 28 :FGM842D Recommended Footprint	34
Figure 29 :FGM842D-P Recommended Footprint.....	34
Figure 32 : Top and Bottom Views (PCB Antenna)	35
Figure 33 : Recommended Reflow Soldering Thermal Profile	37
Figure 34 : Carrier Tape Dimension Drawing (Unit: mm)	39
Figure 35 : Plastic Reel Dimension Drawing	40
Figure 36 : Mounting Direction	40
Figure 37 : Packaging Process	41

1 Introduction

QuecOpen® is a solution where the module acts as the main processor. Constant transition and evolution of both the communication technology and the market highlight its merits. It can help you to:

- Realize embedded applications' quick development and shorten product R&D cycle
- Simplify circuit and hardware structure design to reduce engineering costs
- Miniaturize products
- Reduce product power consumption
- Apply OTA technology
- Enhance product competitiveness and price-performance ratio

This document defines FGM842D series in QuecOpen® solution and describes its air interfaces and hardware interfaces, which are connected with your applications. The document provides a quick insight into interface specifications, RF performance, electrical and mechanical specifications, as well as other related information of the module. The minimum distance between the user and/or any bystander and the radiating structure of the transmitter is 20cm.

Hereby, Quectel Wireless Solutions Co., Ltd. declares that the radio equipment type FGM842D-P is in compliance with Directive 2014/53/EU.

The full text of the EU declaration of conformity is available at the following internet address: <http://www.quectel.com/support/technical.htm>

Disposal of old electrical appliances



The European directive 2012/19/EU on Waste Electrical and Electronic Equipment (WEEE), requires that old household electrical appliances must not be disposed of in the normal unsorted municipal waste stream. Old appliances must be collected separately in order to optimize the recovery and recycling of the materials they contain, and reduce the impact on human health and the environment.

The crossed out "wheeled bin" symbol on the product reminds you of your obligation, that when you dispose of the appliance, it must be separately collected.

Consumers should contact their local authority or retailer for information concerning the correct disposal of their old appliance.

NOTE

For conciseness purposes, FGM842D and FGM842D-P will hereinafter be referred to collectively as

"the module/modules" in parts hereof applicable to both models, and individually as "FGM842D" and "FGM842D-P" in parts hereof referring to the differences between them.

1.1. Special Mark

Table 1: Special Mark

Mark	Definition
[...]	Brackets ([...]) used after a pin enclosing a range of numbers indicate all pins of the same type. For example, SDIO_DATA[0:3] refers to all four SDIO pins: SDIO_DATA0, SDIO_DATA1, SDIO_DATA2, and SDIO_DATA3.

2 Product Overview

FGM842D series is a high performance MCU Wi-Fi 4 and Bluetooth module supporting IEEE 802.11b/g/n and BLE 5.2 standards. It provides multiple interfaces including UART, GPIO, SPI, I2C, PWM and ADC for various applications.

FGM242D is an SMD LCC module with compact packaging. It includes:

- 160 MHz MCU processor
- Built-in 288 KB RAM and 2 MB Flash
- Support for secondary development

Table 2: Basic Information

FGM842D Series	
Packaging type	LGA
Pin counts	61
Dimensions	<ul style="list-style-type: none"> ● FGM842D: (12.5 ± 0.2) mm × (13.2 ± 0.2) mm × (1.8 ± 0.2) mm ● FGM842D-P: (16.6 ± 0.2) mm × (13.2 ± 0.2) mm × (1.8 ± 0.2) mm
Weight	<ul style="list-style-type: none"> ● FGM842D: Approx. 1.05 g ● FGM842D-P: Approx. 1.14 g
Model	FGM842D, FGM842D-P

2.1. Key Features

Table 3: Key Features

Basic Information	
Protocols and Standard	<ul style="list-style-type: none"> ● Wi-Fi Protocols: IEEE 802.11b/g/n ● Bluetooth protocol: BLE 5.2 ● All hardware components are fully compliant with EU RoHS directive
Power Supply	VBAT Power Supply: <ul style="list-style-type: none"> ● 3.0–3.6 V ● Typ.: 3.3 V
Temperature Ranges ¹	<ul style="list-style-type: none"> ● Design Solution 1: <ul style="list-style-type: none"> – Operating temperature: -40 to +85 °C – Storage temperature: -45 to +95 °C ● Design Solution 2: <ul style="list-style-type: none"> – Operating temperature: -40 to +105 °C – Storage temperature: -45 °C to +115 °C
TE-B Kit	FGM842D TE-B ²
Antenna/Antenna Interface	
Antenna/Antenna Interfaces	<ul style="list-style-type: none"> ● FGM842D ³: Pin antenna interface (ANT_WIFI/BT) or RF coaxial connector ● FGM842D-P: PCB antenna ● 50 Ω characteristic impedance
Application Interface ⁴	
Application Interfaces	UART, GPIO, SPI, I2C PWM, ADC, JTAG

¹ The module is provided with two temperature design solutions. For more details, please contact Quectel Technical Support. Within the operating temperature range, the module's related performance meets IEEE and Bluetooth specifications.

² For more details about the EVB, see [document \[1\]](#).

³ FGM842D is provided with one of the two antenna interface designs. For more details, please contact Quectel Technical Support.

⁴ For more details about the interfaces, see [Chapter 3.3](#) and [Chapter 3.4](#).

3 Application Interfaces

3.1. Pin Assignment

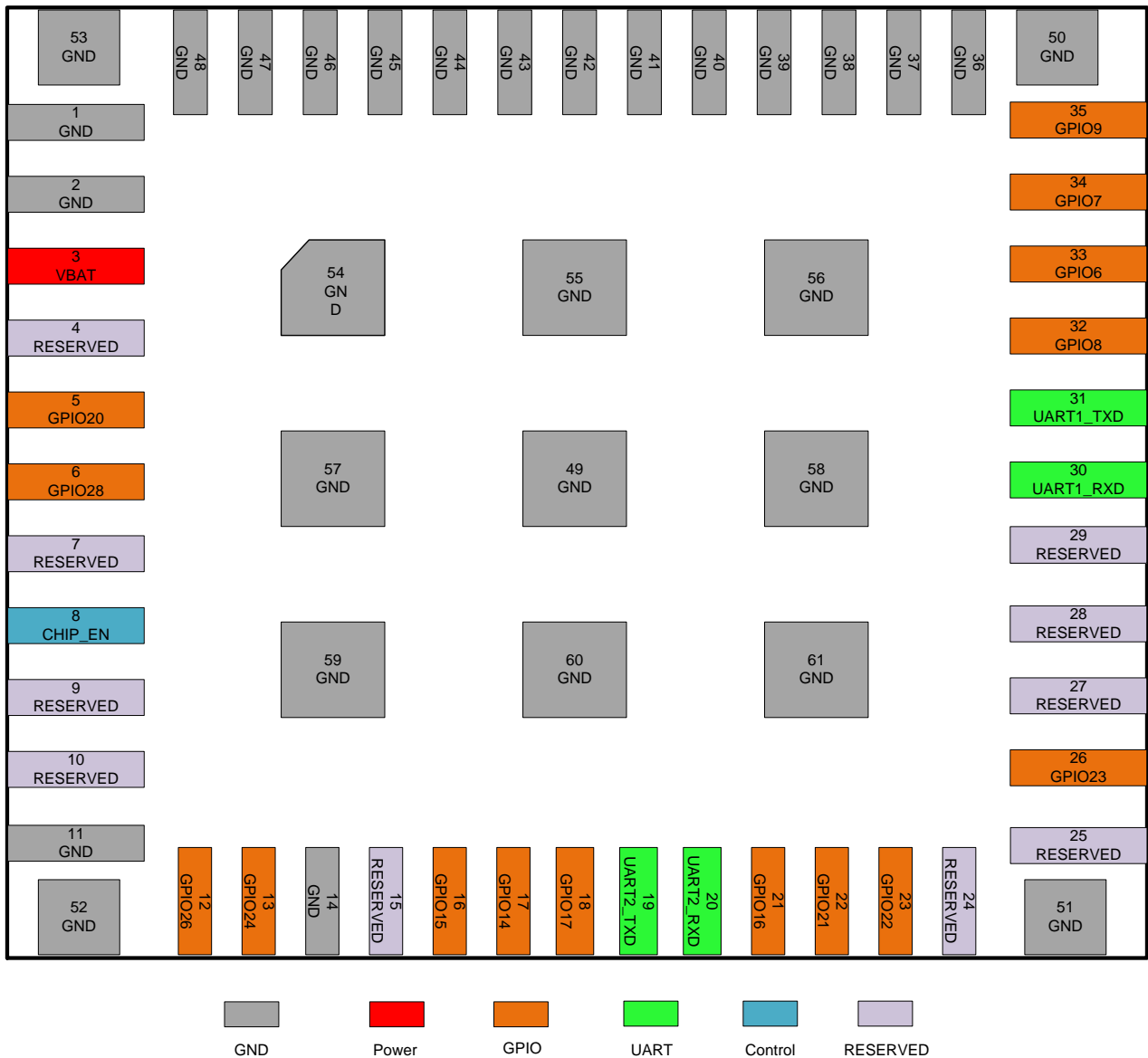

Figure 1:FGM842D-P Pin Assignment (Top View)

NOTE

1. Keep all RESERVED and unused pins unconnected.
2. All GND pins should be connected to ground.
3. The module provides 2 UARTs and 15 GPIO interfaces by default. In the case of multiplexing, it can support interfaces including SPI, I2C, PWM, ADC and JTAG. For more details, see **Chapter 3.3** and **3.4**.

3.2. Pin Description

Table 4: Parameter Description

Parameter	Description
AIO	Analog Input/Output
DI	Digital Input
DO	Digital Output
DIO	Digital Input/Output
PI	Power Input

DC characteristics include power domain and rated current.

Table 5: Pin Description

Power Supply						
Pin Name	Pin No.	I/O	Description	DC Characteristics	Comment	
VBAT	3	PI	Power supply for the module	Vmax = 3.6 V Vmin = 3.0 V Vnom = 3.3 V	It must be provided with sufficient current of at least 0.6 A.	
GND	FGM842D: 1, 2, 11, 14, 36–46, 48–61 FGM842D-P: 1, 2, 11, 14, 36–61					
Control Signal						

Pin Name	Pin No.	I/O	Description	DC Characteristics	Comment
CHIP_EN	8	DI	Enable the module	VBAT	Hardware enable. Internally pulled up to 3.3 V. Active high.

UARTs

Pin Name	Pin No.	I/O	Description	DC Characteristics	Comment
UART1_TXD	31	DO	UART1 transmit	VBAT	
UART1_RXD	30	DI	UART1 receive		
UART2_TXD	19	DO	UART2 transmit		
UART2_RXD	20	DI	UART2 receive		

GPIO Interfaces

Pin Name	Pin No.	I/O	Description	DC Characteristics	Comment
GPIO14	5	DIO	General-purpose input/output	VBAT	Wakeup.
GPIO17	6	DIO	General-purpose input/output		
GPIO16	12	DIO	General-purpose input/output		
GPIO15	13	DIO	General-purpose input/output		
GPIO23	16	DIO	General-purpose input/output		
GPIO6	17	DIO	General-purpose input/output		
GPIO7	18	DIO	General-purpose input/output		
GPIO8	21	DIO	General-purpose input/output		
GPIO9	22	DIO	General-purpose input/output		
GPIO21	23	DIO	General-purpose input/output		
GPIO22	26	DIO	General-purpose input/output		
GPIO28	32	DIO	General-purpose input/output		

GPIO20	33	DIO	General-purpose input/output
GPIO24	34	DIO	General-purpose input/output
GPIO26	35	DIO	General-purpose input/output

FGM842D RF Antenna Interface

Pin Name	Pin No.	I/O	Description	DC Characteristics	Comment
ANT_WIFI/BT	47	AIO	Wi-Fi/Bluetooth antenna interface		50 Ω characteristic impedance.

RESERVED Pins

Pin Name	Pin No.	Comment
RESERVED	4, 7, 9, 10, 15, 24, 25, 27–29	Keep them open.

3.3. GPIO Multiplexing

The module provides 15 GPIO interfaces by default, and can support up to 19 GPIO interfaces in the case of multiplexing. Pins are defined as follows:

Table 6: GPIO Multiplexing

Pin Name	Pin No.	Alternate Function 0 (GPIO No.)	Alternate Function 1	Alternate Function 2	Alternate Function 3	Alternate Function 4
GPIO14	17	GPIO14	SPI_CLK	-	-	-
GPIO17	18	GPIO17	SPI_MISO	I2C1_SDA	-	-
GPIO16	21	GPIO16	SPI_MOSI	-	-	-
GPIO15	16	GPIO15	SPI_CS	I2C1_SCL	-	-
UART2_TXD	19	GPIO0	-	-	-	-
UART2_RXD	20	GPIO1	ADC5	-	-	-
GPIO23	26	GPIO23	-	-	-	-

GPIO6	33	GPIO6	CLK13M	PWM0	JTAG_TCK	-
GPIO7	34	GPIO7	PWM1	JTAG_TMS	-	-
GPIO8	32	GPIO8	PWM2	JTAG_TDI	CLK26M	-
GPIO9	35	GPIO9	PWM3	JTAG_TDO	-	-
GPIO21	22	GPIO21	-	-	-	-
UART1_RXD	30	GPIO10	ADC6	-	-	-
UART1_TXD	31	GPIO11	-	-	-	-
GPIO22	23	GPIO22	-	-	-	-
GPIO28	6	GPIO28	ADC4	-	-	-
GPIO20	5	GPIO20	ADC3	-	-	-
GPIO24	13	GPIO24	LPO_CLK	PWM4	I2C2_SCL	ADC2
GPIO26	12	GPIO26	PWM5	I2C2_SDA	ADC1	-

NOTE

All GPIO can be used as sleep interrupt to wake up the module which will immediately enter the operating state after being awakened.

3.4. Application Interfaces

3.4.1. UARTs

The module provides 2 UARTs by default which can all support full-duplex asynchronous serial communication at a baud rate up to 6 Mbps.

Table 7: Pin Definition of UARTs

Pin Name	Pin No.	I/O	Description
UART1_TXD	31	DO	UART1 transmit
UART1_RXD	30	DI	UART1 receive

UART2_TXD	19	DO	UART2 transmit
UART2_RXD	20	DI	UART2 receive

The UART1 can be used for download and AT command communication and the default baud rate is 115200 bps. The UART1 connection between the module and the MCU is illustrated below.

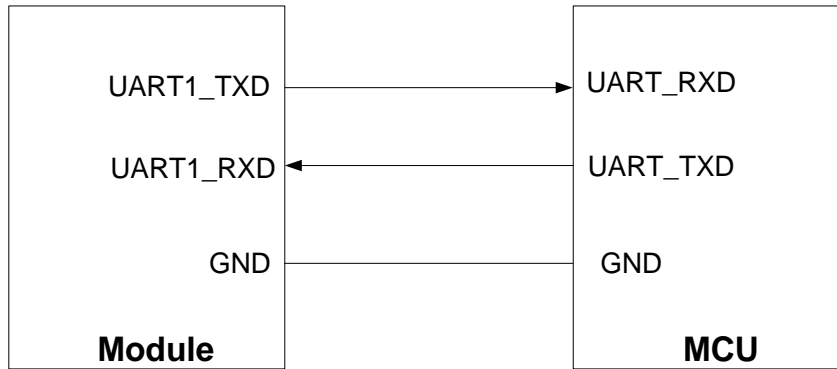

Figure 2: UART1 Connection

The UART2 can be used for the output of partial logs with the debugging tools, and the default baud rate is 921600 bps. The following is reference design of UART2.

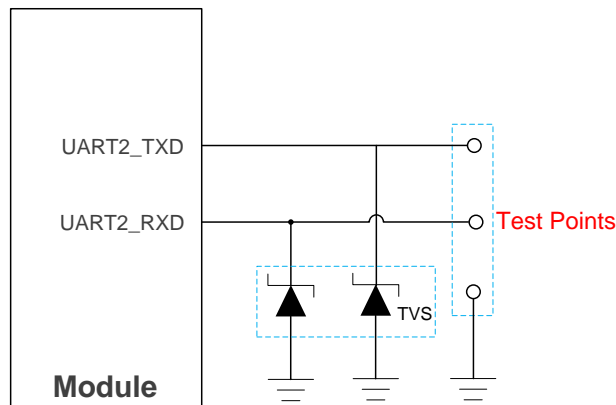

Figure 3: UART2 Reference Design

3.4.2. SPI

In the case of multiplexing, the module provides 1 SPI that supports both master and slave modes. The maximum clock frequency of the interface can reach 30 MHz in master mode, and 20 MHz in slave mode.

Table 8: Pin Definition of SPI

Pin Name	Pin No.	Multiplexing Function	I/O	Description	Comment
GPIO15	16	SPI_CS	DIO	SPI chip select	In master mode, it is an output signal; In slave mode, it is an input signal.
GPIO14	17	SPI_CLK	DIO	SPI clock	In master mode, it is an output signal; In slave mode, it is an input signal.
GPIO17	18	SPI_MISO	DIO	SPI master-in slave-out	
GPIO16	21	SPI_MOSI	DIO	SPI master-out slave-in	

The following figure shows the SPI connection between the host and the slave:

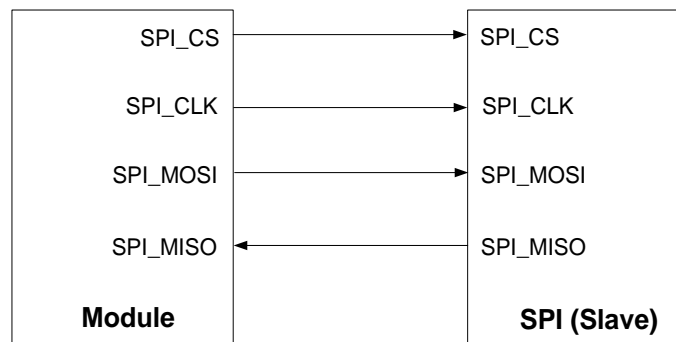

Figure 4: SPI Connection (Master Mode)

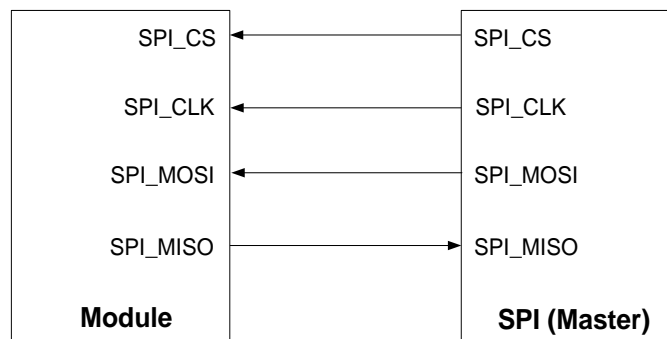

Figure 5: SPI Connection (Slave Mode)

3.4.3. I2C Interfaces

In the case of multiplexing, the module provides up to 1 I2C interfaces which support the master and slave modes. The interfaces support standard (up to 100 kbps) and fast (up to 400 kbps) modes with 7-bit addressing. If low level on SCL or bus idle duration is greater than the software-defined threshold, it will generate an interrupt to the MCU.

Table 9: Pin Definition of I2C Interfaces

Pin Name	Pin No.	Multiplexing Function	I/O	Description
GPIO17	18	I2C_SDA	DIO	I2C serial data
GPIO15	16	I2C_SCL	DO	I2C serial clock
GPIO24	13	I2C_SDA	DIO	I2C serial data
GPIO26	12	I2C_SCL	DO	I2C serial clock

NOTE

Reserve 1–10 k Ω pull-up resistors to VBAT when I2C interfaces are connected to an external equipment.

3.4.4. PWM Interfaces

In the case of multiplexing, the module supports up to 6 32-bit PWM interfaces.

Table 10: Pin Definition of PWM Interfaces

Pin Name	Pin No.	Multiplexing Function	I/O	Description
GPIO6	33	PWM0	DO	PWM0 out
GPIO7	34	PWM1	DO	PWM1 out
GPIO8	32	PWM2	DO	PWM2 out
GPIO9	35	PWM3	DO	PWM3 out
GPIO24	13	PWM4	DO	PWM4 out
GPIO26	12	PWM5	DO	PWM5 out

3.4.5. ADC Interfaces

In the case of multiplexing, the module supports up to 6 10-bit ADC interfaces, whose voltage range is 0~3.3 V. To improve ADC accuracy, surround ADC traces with ground.

Table 11: Pin Definition of ADC Interfaces

Pin Name	Pin No.	Multiplexing Function	I/O	Description
UART2_RXD	20	ADC5	AI	General-purpose ADC interface
UART1_RXD	30	ADC6	AI	General-purpose ADC interface
GPIO28	6	ADC4	AI	General-purpose ADC interface
GPIO20	5	ADC3	AI	General-purpose ADC interface
GPIO24	13	ADC2	AI	General-purpose ADC interface
GPIO26	12	ADC1	AI	General-purpose ADC interface

Table 12: ADC Features

Parameter	Min.	Typ.	Max.	Unit
ADC Voltage Range	0	-	3.3	V
ADC Resolution	-	10	-	bit

4 Operating Characteristics

4.1. Power Supply

Power supply pin and ground pins of the module are defined in the following table.

Table 13: Pin Definition of Power Supply and GND Pins

Pin Name	Pin No.	I/O	Description	Min.	Typ.	Max.	Unit
VBAT	3	PI	Power supply for the module	3.0	3.3	3.6	V
GND	FGM842D: 1, 2, 11, 14, 36–46, 48–61 FGM842D-P: 1, 2, 11, 14, 36–46, 48–61						

4.1.1. Reference Design for Power Supply

The module is powered by VBAT, and it is recommended to use a power supply chip that can provide at least 0.6 A output current. For better power supply performance, it is recommended to parallel a 22 μF decoupling capacitor, and two filter capacitors (1 μF and 100 nF) near the module's VBAT pin. C4 is reserved for debugging and not mounted by default. In addition, it is recommended to add a TVS near the VBAT to improve the surge voltage bearing capacity of the module. In principle, the longer the VBAT trace is, the wider it should be.

VBAT reference circuit is shown below:

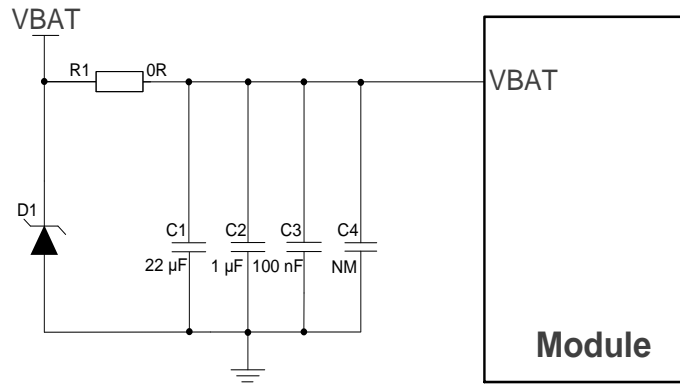

Figure 6: Reference Circuit of Power Supply

4.2. Turn On

After the module VBAT is powered on, keep the CHIP_EN pin at high level to realize the automatic startup of the module.

Table 14: Pin Definition of CHIP_EN

Pin Name	Pin No.	I/O	Description	Comment
CHIP_EN	8	DI	Enable the module	Hardware enable. Internally pulled up to 3.3 V. Active high.

The turn-on timing is shown below:

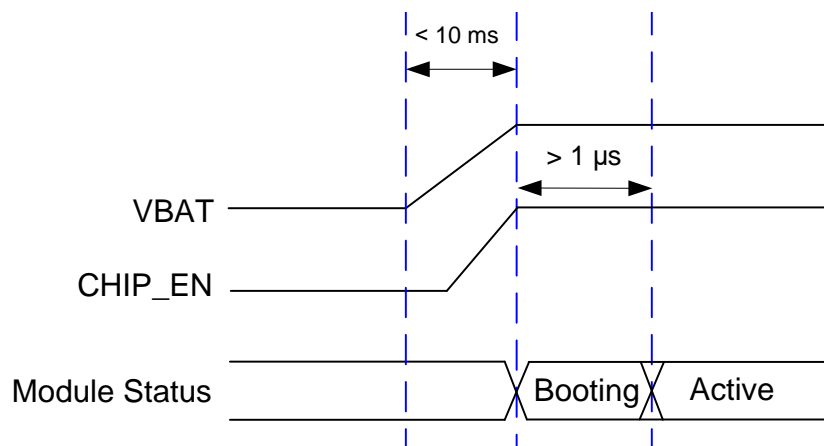

Figure 7: Turn-on Timing

4.3. Reset

When the voltage of CHIP_EN drops below 0.3 V or pull CHIP_EN down for at least 1 ms, the module can be reset. The reference design for hardware resetting of the module are shown below. An open collector driving circuit can be used to control the CHIP_EN pin.

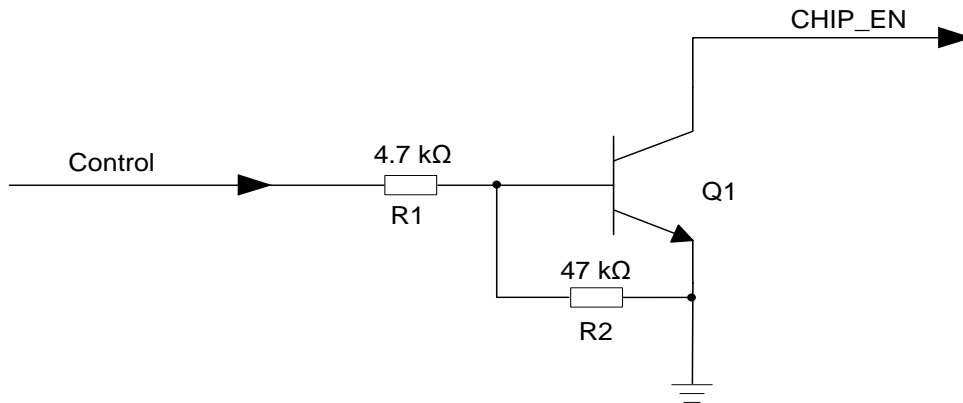

Figure 8: Reference Circuit of CHIP_EN by Using A Driving Circuit

Another way to control the CHIP_EN is by using a button directly. When pressing the button, an electrostatic strike may generate from finger. Therefore, a TVS component shall be placed near the button for ESD protection.

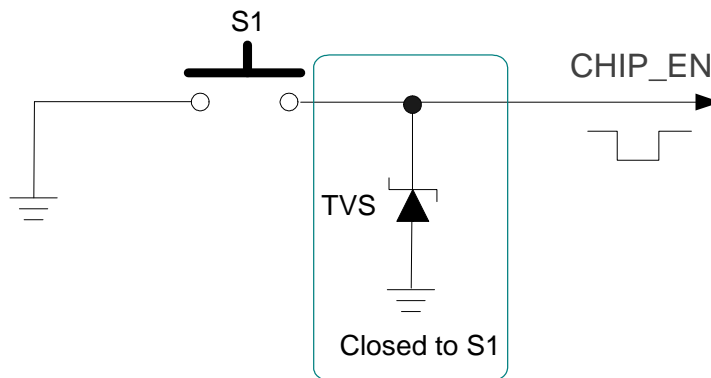
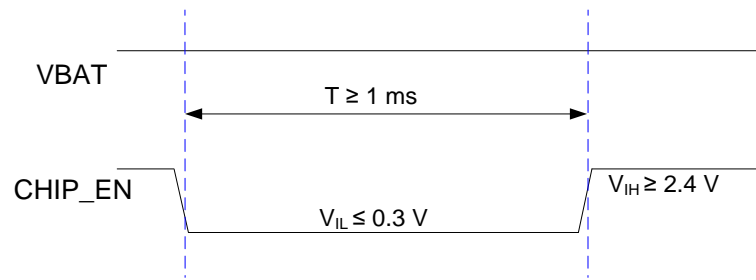

Figure 9: Reference Circuit of RESET with A Button

The module reset timing is illustrated in the following figure.

**Figure 10: Reset Timing**

5 RF Performances

5.1. Wi-Fi Performances

Table 15: Wi-Fi Performances

Operating Frequency				
2.4 GHz: 2.400–2.4835 GHz				
Modulation				
DSSS, CCK, BPSK, QPSK, 16QAM, 64QAM				
Operating Mode				
<ul style="list-style-type: none"> ● AP ● STA ● AP + STA 				
Encryption Mode				
WPA-PSK, WPA2-PSK, WPA3-SAE, AES-128, TRNG				
Transmission Data Rate				
<ul style="list-style-type: none"> ● 802.11b: 1 Mbps, 2 Mbps, 5.5 Mbps, 11 Mbps ● 802.11g: 6 Mbps, 9 Mbps, 12 Mbps, 18 Mbps, 24 Mbps, 36 Mbps, 48 Mbps, 54 Mbps ● 802.11n: HT20 (MCS 0–MCS 7) 				
Condition (VBAT = 3.3 V; Temp.: 25 °C)		EVM	Typ.; Unit: dBm, Tolerance: ±2 dB	
			Transmitting Power	Receiver Sensitivity
2.4 GHz	802.11b @ 1 Mbps	≤ 35 %	16	-98
	802.11b @ 11 Mbps		16	-90
	802.11g @ 6 Mbps	≤ -5 dB	16	-90
	802.11g @ 54 Mbps	≤ -25 dB	15	-76

802.11n, HT20 @ MCS 0	≤ -5 dB	15	-90
802.11n, HT20 @ MCS 7	≤ -27 dB	14	-72

5.2. Bluetooth Performances

Table 16: Bluetooth Performances

Operating Frequency		
2.400–2.4835 GHz		
Modulation		
GFSK		
Operating Mode		
BLE		
Condition (VBAT = 3.3 V; Temp.: 25 °C)	Typ.; Unit: dBm, Tolerance: ±2 dB	
	Transmitting Power	Receiver Sensitivity
BLE (1 Mbps)	6	-96
BLE (2 Mbps)	6	-94
BLE (S = 2)	6	-96
BLE (S = 8)	6	-101

5.3. Antenna/Antenna Interfaces

FGM842D is provided with one of the two antenna interface designs: pin antenna interface (ANT_WIFI/BT) or RF coaxial connector. The RF coaxial connector is not available when the module is designed with ANT_WIFI/BT antenna interface; FGM842D-P supports PCB antenna. The impedance of antenna port is 50 Ω.

Appropriate antenna type and design should be used with matched antenna parameters according to specific application. It is required to perform a comprehensive functional test for the RF design before mass production of terminal products. The entire content of this chapter is provided for illustration only. Analysis, evaluation and determination are still necessary when designing target products.

5.3.1. FGM842D-P PCB Antenna

Table 17: PCB Antenna Specifications

Parameter	Requirement
Frequency Range (GHz)	2.400–2.500
Input Impedance (Ω)	50
VSWR	TBD (Typ.)
Gain (dBi)	TBD (Typ.)
Efficiency	TBD (Avg.)

When designed with PCB antenna, the module should be placed on the edge of the motherboard. The PCB antenna should be at least 16 mm away from the vias, traces, copper pour area, and other components on the motherboard, including connectors and any metal components. On the motherboard, all PCB layers under the PCB antenna should be designed as a keepout area.

To ensure module performance, do not route at the RF test point at the bottom of the module during PCB design. The prohibited area during routing is shown in the red box below:

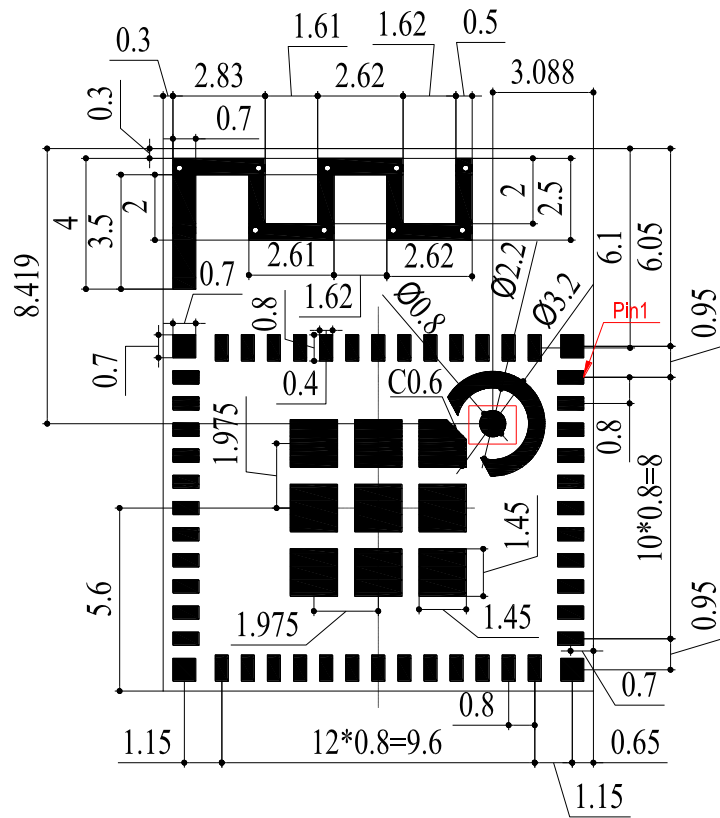

Figure 11: Prohibited Area for Routing (Bottom Side)

6 Electrical Characteristics & Reliability

6.1. Absolute Maximum Ratings

Table 18: Absolute Maximum Ratings (Unit: V)

Parameter	Min.	Max.
VBAT	-0.3	3.6
Voltage at Digital Pins	-0.3	3.6
Voltage at ADC[1:6]	0	3.6

6.2. Power Supply Ratings

Table 19: Module Power Supply Ratings (Unit: V)

Parameter	Description	Condition	Min.	Typ.	Max.
VBAT	Power supply for the module	The actual input voltages must be kept between the minimum and maximum values.	3.0	3.3	3.6

6.3. Power Consumption

6.3.1. Wi-Fi Power Consumption

Table 20: Power Consumption in Non-signaling Mode (Unit: mA)

Condition		I _{BAT} (Typ.)	
802.11b	Tx 1 Mbps @ 18 dBm	267.11	
	Tx 11 Mbps @ 18 dBm	271.50	
2.4 GHz	802.11g	Tx 6 Mbps @ 16 dBm	246.18
		Tx 54 Mbps @ 15 dBm	245.68
802.11n	Tx HT20 MCS 0 @ 15 dBm	245.40	
	Tx HT20 MCS 7 @ 14 dBm	233.00	

6.3.2. Bluetooth Power Consumption

Table 21: Power Consumption in Non-signaling Mode (Unit: mA)

Condition	I _{BAT}
BLE (1 Mbps)	90.54
BLE (2 Mbps)	65.13
BLE (S = 2)	81.73
BLE (S = 8)	103.67

6.4. Digital I/O Characteristics

Table 22: VBAT I/O Requirements (Unit: V)

Parameter	Description	Min.	Max.
V_{IH}	High-level input voltage	$0.7 \times V_{BAT}$	V_{BAT}
V_{IL}	Low-level input voltage	0	$0.3 \times V_{BAT}$
V_{OH}	High-level output voltage	$0.9 \times V_{BAT}$	-
V_{OL}	Low-level output voltage	-	$0.1 \times V_{BAT}$

6.5. ESD Protection

Static electricity occurs naturally and may damage the module. Therefore, applying proper ESD countermeasures and handling methods is imperative. For example, wear anti-static gloves during the development, production, assembly and testing of the module; add ESD protection components to the ESD sensitive interfaces and points in the product design.

Table 23: ESD Characteristics (Unit: kV)

Model	Test Result	Standard
Human Body Model (HBM)	± 2	<i>ANSI/ESDA/JEDEC JS-001-2017</i>
Charged Device Model (CDM)	± 0.5	<i>ANSI/ESDA/JEDEC JS-002-2018</i>

7 Mechanical Information

This chapter describes the mechanical dimensions of the module. All dimensions are measured in millimeters (mm), and the dimensional tolerances are ± 0.2 mm unless otherwise specified.

7.1. Mechanical Dimensions

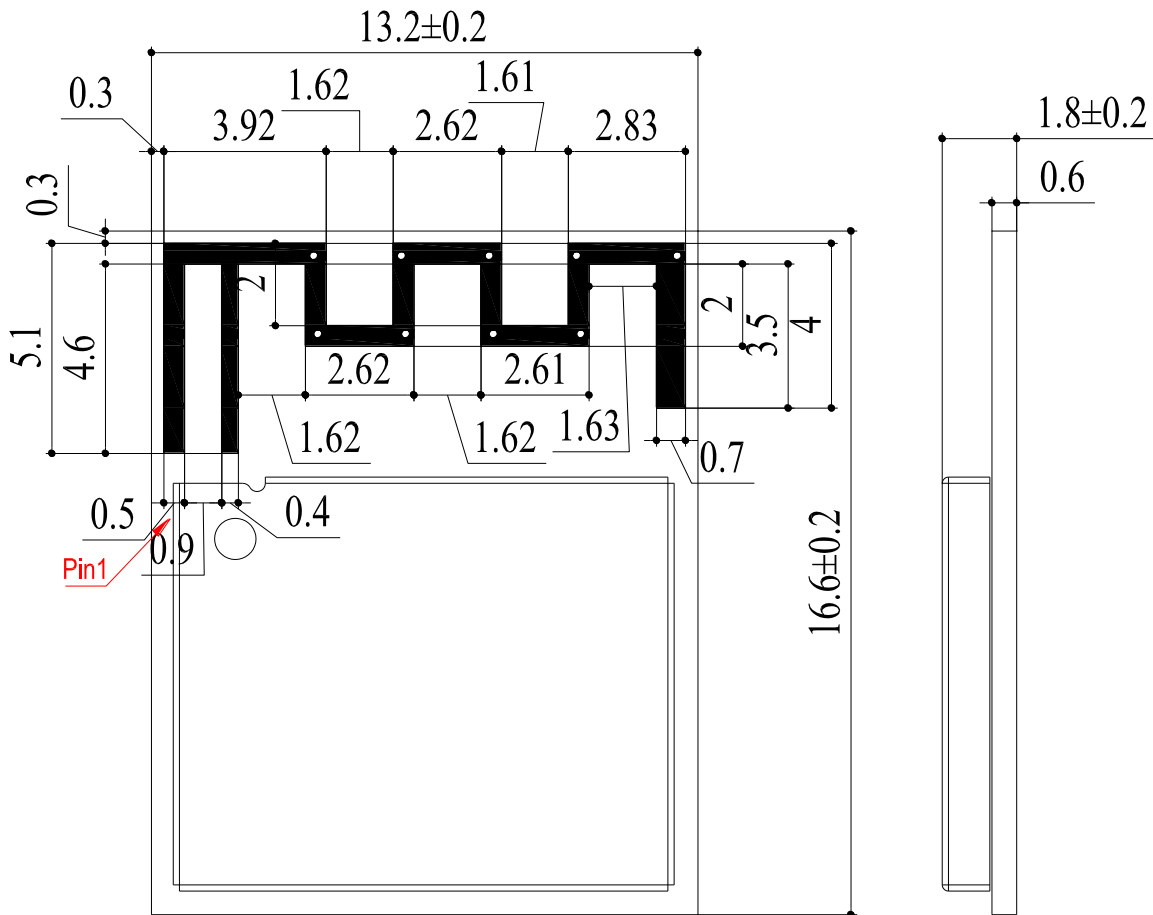

Figure 12: FGM842D-P Top and Side Dimensions

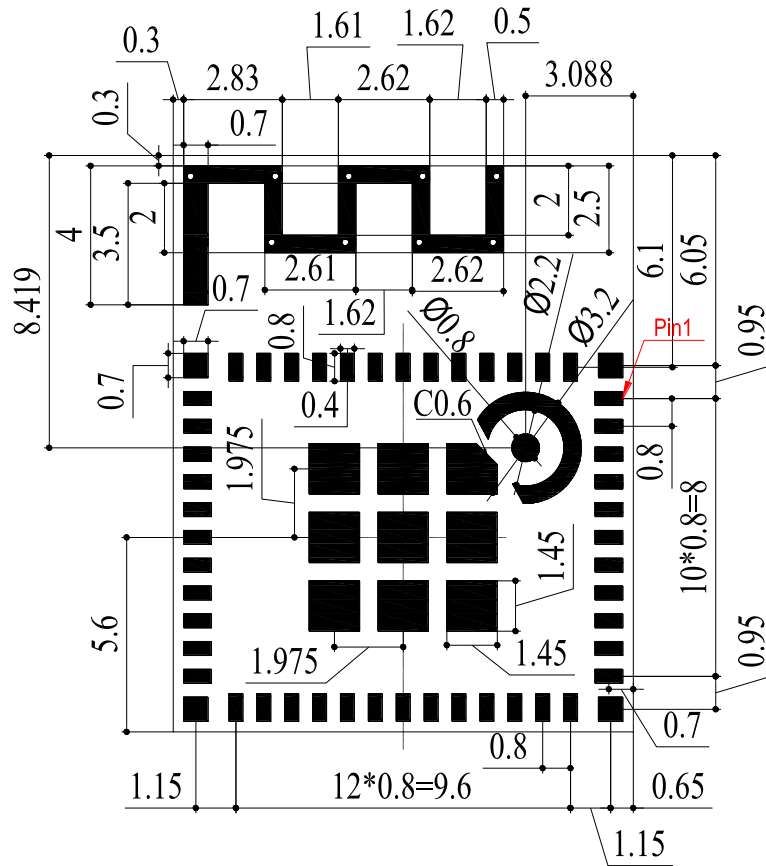

Figure 13:FGM842D-P Bottom Dimensions (Bottom View)

NOTE

The package warpage level of the module refers to the JEITA ED-7306 standard.

7.2. Recommended Footprint

TBD

Figure 14:FGM842D Recommended Footprint

TBD

Figure 15:FGM842D-P Recommended Footprint

NOTE

Keep at least 3 mm between the module and other components on the motherboard to improve soldering quality and maintenance convenience.

7.3. Top and Bottom Views

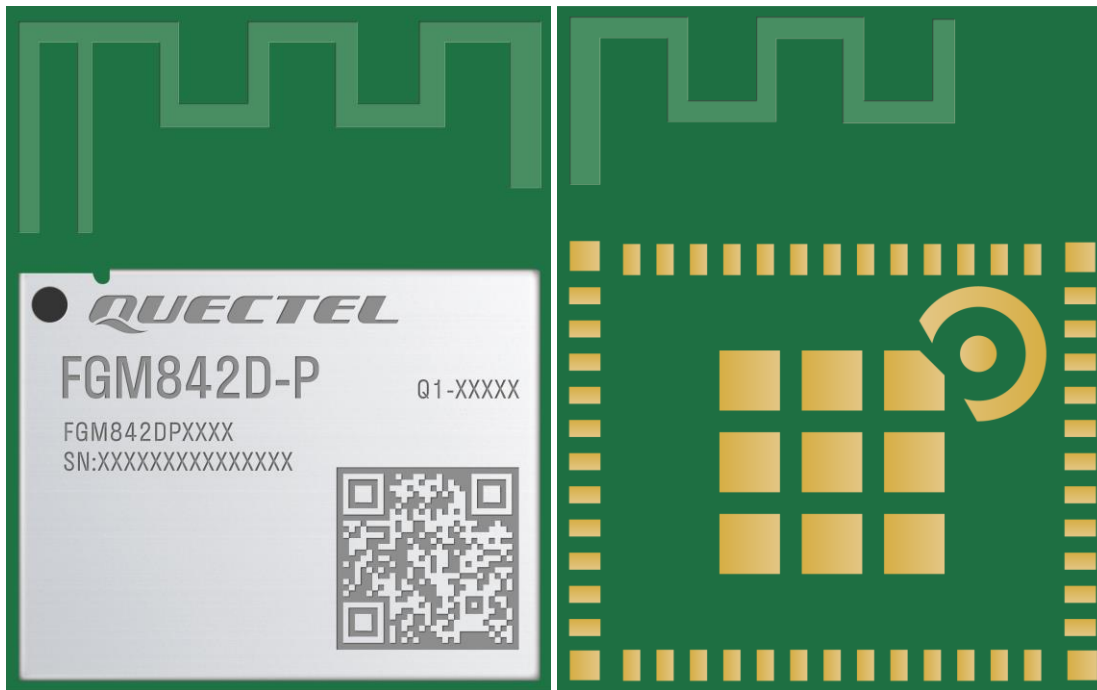

Figure 16: Top and Bottom Views (PCB Antenna)

NOTE

1. Images above are for illustrative purposes only and may differ from the actual module. For authentic appearance and label, please refer to the module received from Quectel.
2. The RF coaxial connector is not mounted on the FGM842D when using pin antenna interface (ANT_WIFI/BT).

8 Storage, Manufacturing & Packaging

8.1. Storage Conditions

The module is provided with vacuum-sealed packaging. MSL of the module is rated as 3. The storage requirements are shown below.

1. Recommended Storage Condition: the temperature should be 23 ± 5 °C and the relative humidity should be 35–60 %.
2. Shelf life (in a vacuum-sealed packaging): 12 months in Recommended Storage Condition.
3. Floor life: 168 hours ⁵ in a factory where the temperature is 23 ± 5 °C and relative humidity is below 60 %. After the vacuum-sealed packaging is removed, the module must be processed in reflow soldering or other high-temperature operations within 168 hours. Otherwise, the module should be stored in an environment where the relative humidity is less than 10 % (e.g., a dry cabinet).
4. The module should be pre-baked to avoid blistering, cracks and inner-layer separation in PCB under the following circumstances:
 - The module is not stored in Recommended Storage Condition;
 - Violation of the third requirement mentioned above;
 - Vacuum-sealed packaging is broken, or the packaging has been removed for over 24 hours;
 - Before module repairing.
5. If needed, the pre-baking should follow the requirements below:
 - The module should be baked for 8 hours at 120 ± 5 °C;
 - The module must be soldered to PCB within 24 hours after the baking, otherwise it should be put in a dry environment such as in a dry cabinet.

⁵ This floor life is only applicable when the environment conforms to *IPC/JEDEC J-STD-033*. It is recommended to start the solder reflow process within 24 hours after the package is removed if the temperature and moisture do not conform to, or are not sure to conform to *IPC/JEDEC J-STD-033*. Do not unpack the modules in large quantities until they are ready for soldering.

NOTE

1. To avoid blistering, layer separation and other soldering issues, extended exposure of the module to the air is forbidden.
2. Take out the module from the package and put it on high-temperature-resistant fixtures before baking. If shorter baking time is desired, see *IPC/JEDEC J-STD-033* for the baking procedure.
3. Pay attention to ESD protection, such as wearing anti-static gloves, when touching the modules.

8.2. Manufacturing and Soldering

Push the squeegee to apply the solder paste on the surface of stencil, thus making the paste fill the stencil openings and then penetrate to the PCB. Apply proper force on the squeegee to produce a clean stencil surface on a single pass. To guarantee module soldering quality, the thickness of stencil for the module is recommended to be 0.12–0.15 mm. For more details, see **document [3]**.

The recommended peak reflow temperature should be 235–246 °C, with 246 °C as the absolute maximum reflow temperature. To avoid damage to the module caused by repeated heating, it is recommended that the module should be mounted only after reflow soldering for the other side of PCB has been completed. The recommended reflow soldering thermal profile (lead-free reflow soldering) and related parameters are shown below.

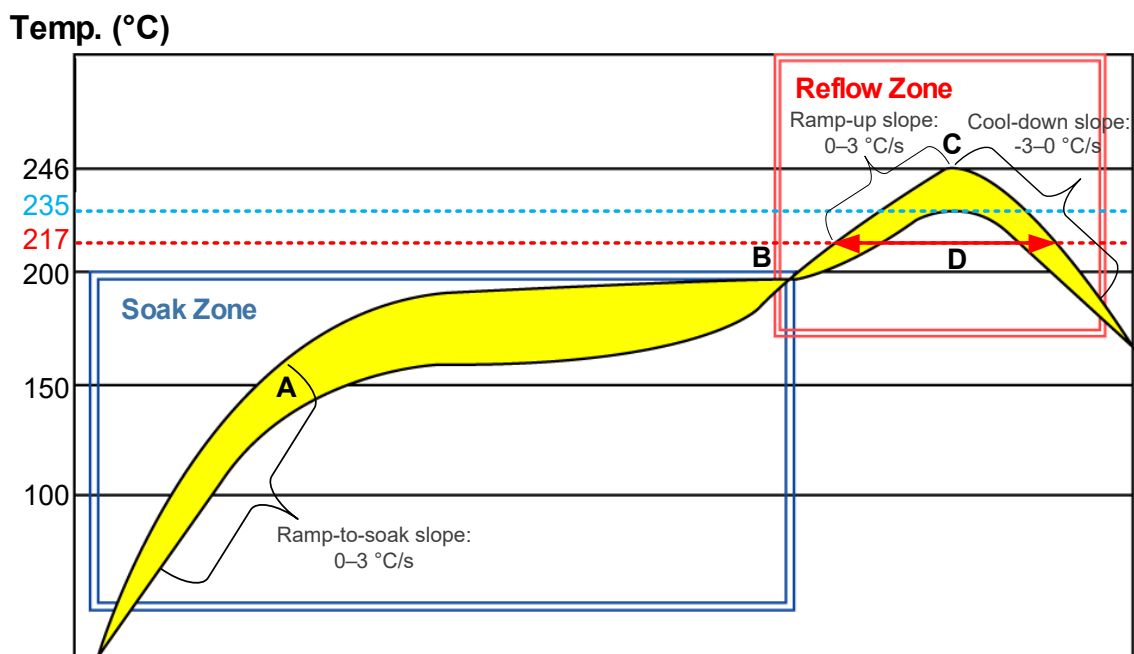

Figure 17: Recommended Reflow Soldering Thermal Profile

Table 24: Recommended Thermal Profile Parameters

Factor	Recommended Value
Soak Zone	
Ramp-to-soak slope	0–3 °C/s
Soak time (between A and B: 150 °C and 200 °C)	70–120 s
Reflow Zone	
Ramp-up slope	0–3 °C/s
Reflow time (D: over 217 °C)	40–70 s
Max. temperature	235–246 °C
Cool-down slope	-3–0 °C/s
Reflow Cycle	
Max. reflow cycle	1

NOTE

1. The above profile parameter requirements are for the measured temperature of solder joints. Both the hottest and coldest spots of solder joints on the PCB should meet the above requirements.
2. During manufacturing and soldering, or any other processes that may contact the module directly, NEVER wipe the module’s shielding can with organic solvents, such as acetone, ethyl alcohol, isopropyl alcohol, trichloroethylene, etc. Otherwise, the shielding can may become rusted.
3. The shielding can for the module is made of Cupro-Nickel base material. It is tested that after 12 hours’ Neutral Salt Spray test, the laser engraved label information on the shielding can is still clearly identifiable and the QR code is still readable, although white rust may be found.
4. If a conformal coating is necessary for the module, do NOT use any coating material that may chemically react with the PCB or shielding cover, and prevent the coating material from flowing into the module.
5. Avoid using ultrasonic technology for module cleaning since it can damage crystals inside the module.
6. Due to the complexity of the SMT process, please contact Quectel Technical Support in advance for any situation that you are not sure about, or any process (e.g. selective soldering, ultrasonic soldering) that is not mentioned in **document [3]**.

8.3. Packaging Specification

This chapter outlines the key packaging parameters and processes. All figures below are for reference purposes only, as the actual appearance and structure of packaging materials may vary in delivery.

The modules are packed in a tape and reel packaging as specified in the sub-chapters below.

8.3.1. Carrier Tape

Carrier tape dimensions are illustrated in the following figure and table:

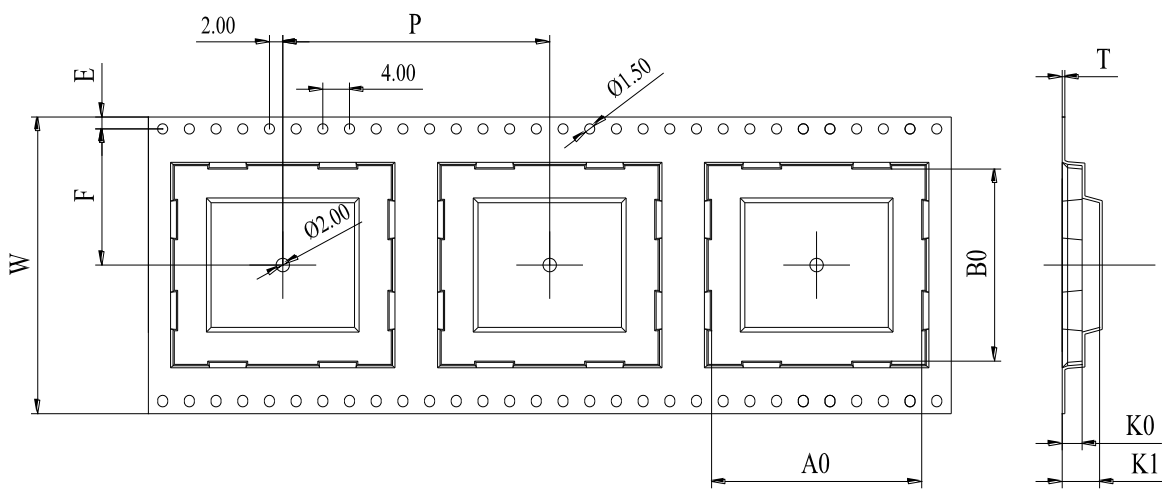

Figure 18: Carrier Tape Dimension Drawing (Unit: mm)

Table 25: FGM842D Carrier Tape Dimension Table (Unit: mm)

W	P	T	A0	B0	K0	K1	F	E
32	24	0.4	13.6	12.6	2.3	3.2	14.2	1.75

Table 26: FGM842D-P Carrier Tape Dimension Table (Unit: mm)

W	P	T	A0	B0	K0	K1	F	E
32	24	0.4	13.6	17	2.3	3.2	14.2	1.75

8.3.2. Plastic Reel

Plastic reel dimensions are illustrated in the following figure and table:

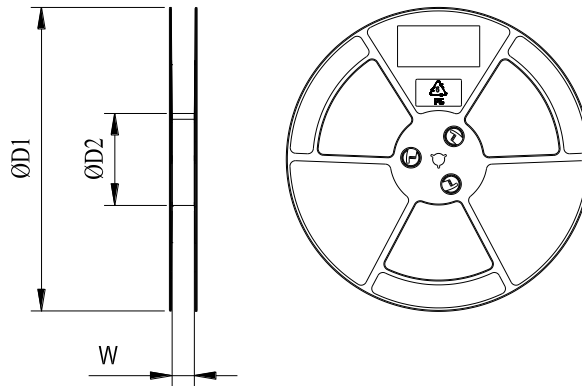

Figure 19: Plastic Reel Dimension Drawing

Table 27: Plastic Reel Dimension Table (Unit: mm)

øD1	øD2	W
380	100	32.5

8.3.3. Mounting Direction

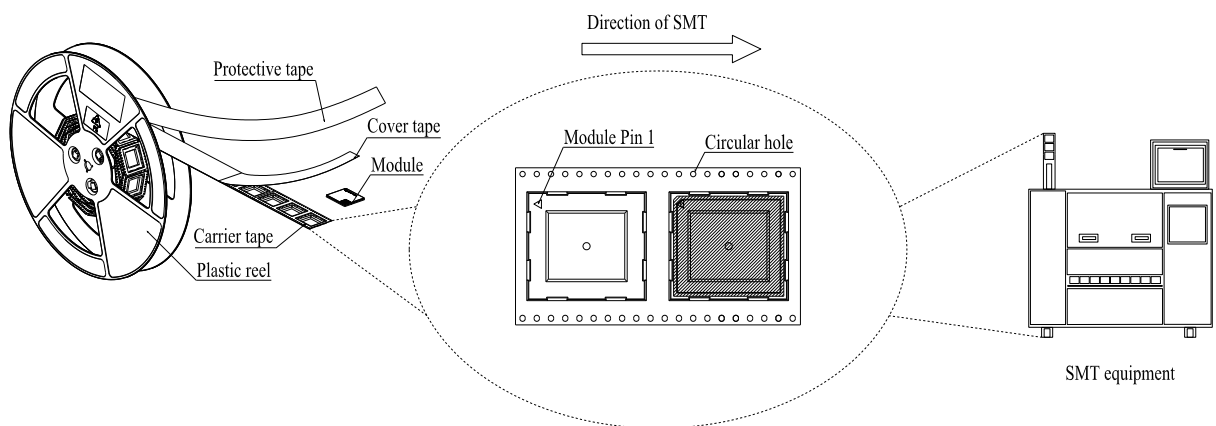
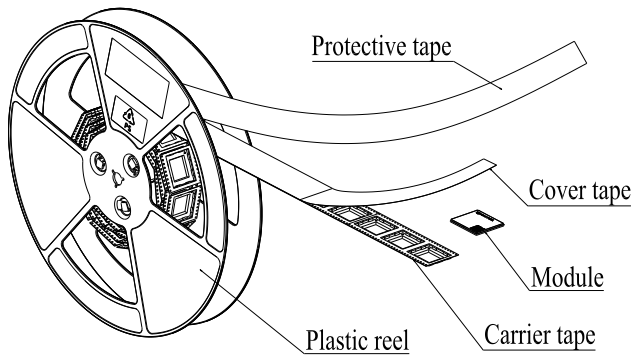

Figure 20: Mounting Direction

8.3.4. Packaging Process



Place the modules onto the carrier tape cavity and cover them securely with cover tape. Wind the heat-sealed carrier tape onto a plastic reel and apply a protective tape for additional protection. 1 plastic reel can pack 1000 modules.

Place the packaged plastic reel, humidity indicator card and desiccant bag into a vacuum bag, and vacuumize it.

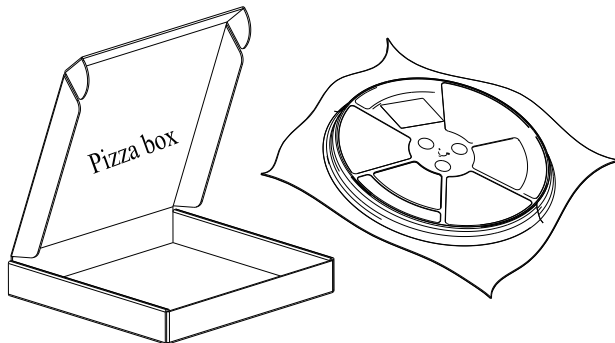
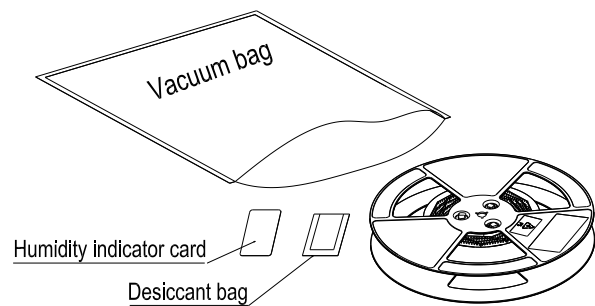

Place the vacuum-packed plastic reel into a pizza box.

Place the 4 packaged pizza boxes into 1 carton and seal it. 1 carton can pack 4000 modules.

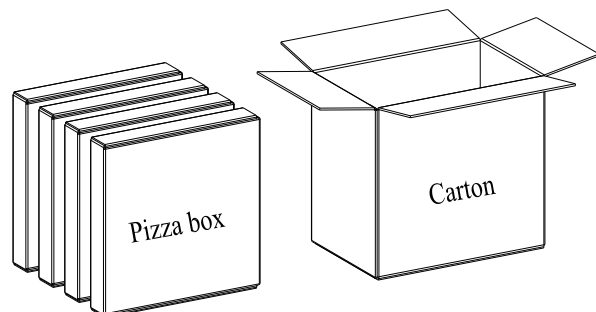

Figure 21: Packaging Process

9 Appendix References

Table 28: Reference Documents

Document Name
[1] Quectel_FGM842D_TE-B_User_Guide
[2] Quectel_RF_Layout_Application_Note
[3] Quectel_Module_SMT_Application_Note

Table 29: Terms and Abbreviations

Abbreviation	Description
ADC	Analog-to-Digital Converter
AES	Advanced Encryption Standard
AP	Access Point
BLE	Bluetooth Low Energy
BPSK	Binary Phase Shift Keying
CCK	Complementary Code Keying
CDM	Charged Device Model
DSSS	Direct Sequence Spread Spectrum
ESD	Electrostatic Discharge
EVM	Error Vector Magnitude
GFSK	Gauss frequency Shift Keying
GND	Ground
GPIO	General-Purpose Input/Output

HT	High Throughput
I/O	Input/Output
I2C	Inter-Integrated Circuit
IEEE	Institute of Electrical and Electronics Engineers
JTAG	Joint Test Action Group
LCC	Leadless Chip Carrier (package)
Mbps	Million Bits Per Second
MCU	Microcontroller Unit
MISO	Master In Slave Out
MOSI	Master Out Slave In
OTA	Over-the-Air
PCB	Printed Circuit Board
PSK	Pre-Shared Key
PWM	Pulse Width Modulation
QAM	Quadrature Amplitude Modulation
QPSK	Quadrature Phase Shift Keying
RAM	Random Access Memory
RF	Radio Frequency
RoHS	Restriction of Hazardous Substances
SAE	Simultaneous Authentication of Equals
SMD	Surface Mount Device
SMT	Surface Mount Technology
SPI	Serial Peripheral Interface
STA	Station
TRNG	True Random Number Generator
TVS	Transient Voltage Suppressor
Tx	Transmit

UART	Universal Asynchronous Receiver/Transmitter
(U)SIM	(Universal) Subscriber Identity Module
V _{IH}	High-level Input Voltage
V _{IL}	Low-level Input Voltage
V _{max}	Maximum Voltage
V _{min}	Minimum Voltage
V _{nom}	Nominal Voltage Value
V _{OH}	High-level Output Voltage
V _{OL}	Low-level Output Voltage
VSWR	Voltage Standing Wave Ratio
WPA	Wi-Fi Protected Access

FCC Certification Requirements.

Note: The corresponding FCC ID/IC number is FGM842D-P.

According to the definition of mobile and fixed device is described in Part 2.1091(b), this device is a mobile device.

And the following conditions must be met:

1. This Modular Approval is limited to OEM installation for mobile and fixed applications only. The antenna installation and operating configurations of this transmitter, including any applicable source-based time- averaging duty factor, antenna gain and cable loss must satisfy MPE categorical Exclusion Requirements of 2.1091.

2. The EUT is a mobile device; maintain at least a 20 cm separation between the EUT and the user' s body and must not transmit simultaneously with any other antenna or transmitter.

3.A label with the following statements must be attached to the host end product: This device contains FCC ID: XMR2024FGM842DP.

4.To comply with FCC regulations limiting both maximum RF output power and human exposure to RF radiation, maximum antenna gain (including cable loss) must not exceed:

□ Bluetooth/Bluetooth LE/Wi-Fi 2.4G: ≤ 1.7 dBi

5. This module must not transmit simultaneously with any other antenna or transmitter

6. The host end product must include a user manual that clearly defines operating requirements and conditions that must be observed to ensure compliance with current FCC RF exposure guidelines.

For portable devices, in addition to the conditions 3 through 6 described above, a separate approval is required to satisfy the SAR requirements of FCC Part 2.1093

If the device is used for other equipment that separate approval is required for all other operating configurations, including portable configurations with respect to 2.1093 and different antenna configurations.

For this device, OEM integrators must be provided with labeling instructions of finished products. Please refer to KDB784748 D01 v07, section 8. Page 6/7 last two paragraphs:

A certified modular has the option to use a permanently affixed label, or an electronic label. For a permanently affixed label, the module must be labeled with an FCC ID - Section 2.926 (see 2.2 Certification (labeling requirements) above). The OEM manual must provide clear instructions explaining to the OEM the labeling requirements, options and OEM user manual instructions that are required (see next paragraph).

For a host using a certified modular with a standard fixed label, if (1) the module' s FCC ID is not visible when installed in the host, or (2) if the host is marketed so that end users do not have straightforward commonly used methods for access to remove the module so that the FCC ID of the module is visible; then an additional permanent label referring to the enclosed module: "Contains Transmitter Module FCC ID: XMR2024FGM842DP." or "Contains FCC ID: XMR2024FGM842DP." must be used. The host OEM user manual must also contain clear instructions on how end users can find and/or access the module and the FCC ID.

The final host / module combination may also need to be evaluated against the FCC Part 15B criteria for unintentional radiators in order to be properly authorized for operation as a Part 15 digital device.

The user' s manual or instruction manual for an intentional or unintentional radiator shall caution the user that changes or modifications not expressly approved by the party responsible for compliance could void the user's authority to operate the equipment. In cases where the manual is provided only in a form other

than paper, such as on a computer disk or over the Internet, the information required by this section may be included in the manual in that alternative form, provided the user can reasonably be expected to have the capability to access information in that form.

This device complies with part 15 of the FCC Rules. Operation is subject to the following two conditions: (1) This device may not cause harmful interference, and (2) this device must accept any interference received, including interference that may cause undesired operation.

Changes or modifications not expressly approved by the manufacturer could void the user's authority to operate the equipment.

IC Certification Requirements.

This device contains licence-exempt transmitter(s)/receiver(s) that comply with Innovation, Science and Economic Development Canada's licence-exempt RSS(s). Operation is subject to the following two conditions:

1. This device may not cause interference.
2. This device must accept any interference, including interference that may cause undesired operation of the device.

To comply with IC regulations limiting both maximum RF output power and human exposure to RF radiation, maximum antenna gain (including cable loss) must not exceed:

□ Bluetooth/Bluetooth LE/Wi-Fi 2.4G: ≤ 1.7 dBi

L'appareil contient un émetteur / récepteur exempté de licence conforme au CNR exempté de licence d'innovation, sciences et développement économique Canada. Les opérations sont soumises aux deux conditions suivantes:

1. Cet appareil peut ne pas causer d'interférence.

L'appareil doit accepter toute interférence, y compris celles qui peuvent entraîner un fonctionnement indésirable de l'appareil.

This equipment complies with ISED radiation exposure limits set forth for an uncontrolled environment. To comply with RSS-102 RF Exposure compliance requirements, this grant is applicable to only Mobile Configurations. The antennas used for the transmitter must be installed to provide a separation distance of at least 20cm from all persons and must not be co-located or operating in conjunction with any other antenna or transmitter.

The host product shall be properly labelled to identify the modules within the host product.

The Innovation, Science and Economic Development Canada certification label of a module shall be clearly visible at all times when installed in the host product; otherwise, the host product must be labeled to display the Innovation, Science and Economic Development Canada certification number for the module, preceded by the word "Contains" or similar wording expressing the same meaning, as follows:

“Contains IC: 10224A-024FGM842DP” or “where: 10224A-024FGM842DP is the module’s certification number” .