

FCU760K-N

Hardware Design

Wi-Fi&Bluetooth Module Series

Version: 1.0.0

Date: 2023-06-27

Status: Preliminary



At Quectel, our aim is to provide timely and comprehensive services to our customers. If you require any assistance, please contact our headquarters:

Quectel Wireless Solutions Co., Ltd.

Building 5, Shanghai Business Park Phase III (Area B), No.1016 Tianlin Road, Minhang District, Shanghai 200233, China

Tel: +86 21 5108 6236

Email: info@quectel.com

Or our local offices. For more information, please visit:

<http://www.quectel.com/support/sales.htm>.

For technical support, or to report documentation errors, please visit:

<http://www.quectel.com/support/technical.htm>.

Or email us at: support@quectel.com.

Legal Notices

We offer information as a service to you. The provided information is based on your requirements and we make every effort to ensure its quality. You agree that you are responsible for using independent analysis and evaluation in designing intended products, and we provide reference designs for illustrative purposes only. Before using any hardware, software or service guided by this document, please read this notice carefully. Even though we employ commercially reasonable efforts to provide the best possible experience, you hereby acknowledge and agree that this document and related services hereunder are provided to you on an “as available” basis. We may revise or restate this document from time to time at our sole discretion without any prior notice to you.

Use and Disclosure Restrictions

License Agreements

Documents and information provided by us shall be kept confidential, unless specific permission is granted. They shall not be accessed or used for any purpose except as expressly provided herein.

Copyright

Our and third-party products hereunder may contain copyrighted material. Such copyrighted material shall not be copied, reproduced, distributed, merged, published, translated, or modified without prior written consent. We and the third party have exclusive rights over copyrighted material. No license shall be granted or conveyed under any patents, copyrights, trademarks, or service mark rights. To avoid ambiguities, purchasing in any form cannot be deemed as granting a license other than the normal non-exclusive, royalty-free license to use the material. We reserve the right to take legal action for noncompliance with abovementioned requirements, unauthorized use, or other illegal or malicious use of the material.

Trademarks

Except as otherwise set forth herein, nothing in this document shall be construed as conferring any rights to use any trademark, trade name or name, abbreviation, or counterfeit product thereof owned by Quectel or any third party in advertising, publicity, or other aspects.

Third-Party Rights

This document may refer to hardware, software and/or documentation owned by one or more third parties (“third-party materials”). Use of such third-party materials shall be governed by all restrictions and obligations applicable thereto.

We make no warranty or representation, either express or implied, regarding the third-party materials, including but not limited to any implied or statutory, warranties of merchantability or fitness for a particular purpose, quiet enjoyment, system integration, information accuracy, and non-infringement of any third-party intellectual property rights with regard to the licensed technology or use thereof. Nothing herein constitutes a representation or warranty by us to either develop, enhance, modify, distribute, market, sell, offer for sale, or otherwise maintain production of any our products or any other hardware, software, device, tool, information, or product. We moreover disclaim any and all warranties arising from the course of dealing or usage of trade.

Privacy Policy

To implement module functionality, certain device data are uploaded to Quectel’s or third-party’s servers, including carriers, chipset suppliers or customer-designated servers. Quectel, strictly abiding by the relevant laws and regulations, shall retain, use, disclose or otherwise process relevant data for the purpose of performing the service only or as permitted by applicable laws. Before data interaction with third parties, please be informed of their privacy and data security policy.

Disclaimer

- a) We acknowledge no liability for any injury or damage arising from the reliance upon the information.
- b) We shall bear no liability resulting from any inaccuracies or omissions, or from the use of the information contained herein.
- c) While we have made every effort to ensure that the functions and features under development are free from errors, it is possible that they could contain errors, inaccuracies, and omissions. Unless otherwise provided by valid agreement, we make no warranties of any kind, either implied or express, and exclude all liability for any loss or damage suffered in connection with the use of features and functions under development, to the maximum extent permitted by law, regardless of whether such loss or damage may have been foreseeable.
- d) We are not responsible for the accessibility, safety, accuracy, availability, legality, or completeness of information, advertising, commercial offers, products, services, and materials on third-party websites and third-party resources.

Copyright © Quectel Wireless Solutions Co., Ltd. 2023. All rights reserved.

Safety Information

The following safety precautions must be observed during all phases of operation, such as usage, service or repair of any terminal or mobile incorporating the module. Manufacturers of the terminal should notify users and operating personnel of the following safety information by incorporating these guidelines into all manuals of the product. Otherwise, Quectel assumes no liability for customers' failure to comply with these precautions.



Full attention must be given to driving at all times in order to reduce the risk of an accident. Using a mobile while driving (even with a handsfree kit) causes distraction and can lead to an accident. Please comply with laws and regulations restricting the use of wireless devices while driving.



Switch off the terminal or mobile before boarding an aircraft. The operation of wireless appliances in an aircraft is forbidden to prevent interference with communication systems. If there is an Airplane Mode, it should be enabled prior to boarding an aircraft. Please consult the airline staff for more restrictions on the use of wireless devices on an aircraft.



Wireless devices may cause interference on sensitive medical equipment, so please be aware of the restrictions on the use of wireless devices when in hospitals, clinics or other healthcare facilities.



Terminals or mobiles operating over radio signal and cellular network cannot be guaranteed to connect in certain conditions, such as when the mobile bill is unpaid or the (U)SIM card is invalid. When emergency help is needed in such conditions, use emergency call if the device supports it. In order to make or receive a call, the terminal or mobile must be switched on in a service area with adequate cellular signal strength. In an emergency, the device with emergency call function cannot be used as the only contact method considering network connection cannot be guaranteed under all circumstances.



The terminal or mobile contains a transceiver. When it is ON, it receives and transmits radio frequency signals. RF interference can occur if it is used close to TV sets, radios, computers or other electric equipment.



In locations with explosive or potentially explosive atmospheres, obey all posted signs and turn off wireless devices such as mobile phone or other terminals. Areas with explosive or potentially explosive atmospheres include fueling areas, below decks on boats, fuel or chemical transfer or storage facilities, and areas where the air contains chemicals or particles such as grain, dust or metal powders.

About the Document

Revision History

Version	Date	thor	Description
-	2023-06-27	Echo XIANG/James XIONG	Creation of the document
1.0.0	2023-06-27	Echo XIANG/James XIONG	Preliminary

Contents

Safety Information	3
About the Document	4
Contents	5
Table Index	7
Figure Index	8
1 Introduction	9
2 Product Overview	10
2.1. Key Features.....	11
2.2. Functional Diagram.....	12
3 RF Performances	13
3.1. Wi-Fi Performances	13
3.2. Bluetooth Performances	14
4 Application Interfaces	16
4.1. Pin Assignment.....	16
4.2. Pin Description	17
4.3. Power Supply	18
4.4. Wi-Fi/Bluetooth Application Interface.....	20
4.4.1. USB Interface.....	21
4.5. RF Antenna Interface.....	21
4.5.1. Reference Design	22
4.5.2. RF Routing Guidelines.....	23
4.5.3. RF Connector Recommendation	24
5 Electrical Characteristics & Reliability	27
5.1. Absolute Maximum Ratings	27
5.2. Power Supply Ratings.....	27
5.3. ESD Protection.....	27
5.4. Power Consumption.....	28
5.4.1. Wi-Fi Power Consumption	28
5.4.2. Bluetooth Power Consumption	29
5.5. Digital I/O Characteristics	30
5.6. Thermal Dissipation	30
6 Mechanical Information	32
6.1. Mechanical Dimensions.....	32
6.2. Recommended Footprint	34
6.3. Top and Bottom Views.....	35
7 Storage, Manufacturing & Packaging	36
7.1. Storage Conditions.....	36
7.2. Manufacturing and Soldering.....	37

7.3. Packaging Specifications	39
7.3.1. Carrier Tape	39
7.3.2. Plastic Reel	40
7.3.3. Mounting Direction	40
7.3.4. Packaging Process	41
8 Appendix References	42

Table Index

Table 1: Basic Information	10
Table 2: Key Features	11
Table 3: Wi-Fi Performances	13
Table 5: Bluetooth Performances	15
Table 7: I/O Parameters Definition.....	17
Table 8: Pin Description	17
Table 9: Antenna Design Requirements	22
Table 10: Absolute Maximum Ratings (Unit: V).....	27
Table 11: Module Power Supply Ratings (Unit: V)	27
Table 12: Electrostatics Discharge Characteristics (Unit: kV)	28
Table 4: Wi-Fi Power Consumption	28
Table 6: Bluetooth Power Consumption in Non-signalling Modes	29
Table 13: Digital I/O Characteristics (Unit: V)	30
Table 14: Recommended Thermal Profile Parameters	38
Table 15: Carrier Tape Dimension Table (Unit: mm).....	39
Table 16: Plastic Reel Dimension Table (Unit: mm).....	40
Table 17: Related Documents.....	42
Table 18: Terms and Abbreviations	42

Figure Index

Figure 1: Functional Diagram.....	12
Figure 2: Pin Assignment (Top View)	16
Figure 3: Reference Circuit of Power Supply.....	19
Figure 4: Power-up Timing.....	19
Figure 5: Wi-Fi Application Interface Connection	20
Figure 6: Bluetooth Application Interface Connection	20
Figure 7: USB Interface Connection	21
Figure 8: Reference Circuit for RF Antenna Interface	22
Figure 9: Microstrip Design on a 2-layer PCB	23
Figure 10: Coplanar Waveguide Design on a 2-layer PCB	23
Figure 11: Coplanar Waveguide Design on a 4-layer PCB (Layer 3 as Reference Ground).....	23
Figure 12: Coplanar Waveguide Design on a 4-layer PCB (Layer 4 as Reference Ground).....	24
Figure 13: Dimensions of the Receptacle (Unit: mm).....	25
Figure 14: Specifications of Mated Plugs	25
Figure 15: Space Factor of Mated Connectors (Unit: mm).....	26
Figure 16: Placement and Fixing of the Heatsink.....	31
Figure 17: Top and Side Dimensions.....	32
Figure 18: Bottom Dimension (Bottom View).....	33
Figure 19: Recommended Footprint	34
Figure 20: Top and Bottom Views.....	35
Figure 21: Recommended Reflow Soldering Thermal Profile	37
Figure 22: Carrier Tape Dimension Drawing	39
Figure 23: Plastic Reel Dimension Drawing	40
Figure 24: Mounting Direction	40
Figure 25: Packaging Process	41

1 Introduction

This document defines the FCU760K-N and describes its air interfaces and hardware interfaces which are connected with your applications.

With this document, you can quickly understand module interface specifications, electrical and mechanical details, as well as other related information of the module. The document, coupled with application notes and user guides, makes it easy to design and set up mobile applications with the module.

Hereby, Quectel Wireless Solutions Co., Ltd. declares that the radio equipment type FCU760K-N is in compliance with Directive 2014/53/EU.

The full text of the EU declaration of conformity is available at the following internet address: <http://www.quectel.com/support/technical.htm>

The device could be used with a separation distance of 20cm to the human body.

Disposal of old electrical appliances



The European directive 2012/19/EU on Waste Electrical and Electronic Equipment (WEEE), requires that old household electrical appliances must not be disposed of in the normal unsorted municipal waste stream. Old appliances must be collected separately in order to optimize the recovery and recycling of the materials they contain, and reduce the impact on human health and the environment.

The crossed out "wheeled bin" symbol on the product reminds you of your obligation, that when you dispose of the appliance, it must be separately collected.

Consumers should contact their local authority or retailer for information concerning the correct disposal of their old appliance.

The WLAN function for this device is restricted to indoor use only when operating in the 5150 to 5350 MHz frequency range.

2 Product Overview

FCU760K-N is a low-energy, high-performance IEEE 802.11a/b/g/n/ac/ax Wi-Fi 6 and Bluetooth 5.4 module. It supports 2.4 GHz, 5 GHz Wi-Fi and 1T1R with maximum data transmission rate up to 286.8 Mbps. It provides USB 2.0 interface for Wi-Fi function and Bluetooth function.

It is an SMD module with compact packaging. Related information is listed in the table below:

Table 1: Basic Information

FCU760K-N	
Packaging type	LCC
Pin counts	22
Dimensions	(13.0 ±0.15) mm × (12.2 ±0.15) mm × (2.0 ±0.2) mm
Weight	Approx. 0.62 g

2.1. Key Features

Table 2: Key Features

Basic Information	
Protocols and Standard	<ul style="list-style-type: none"> ● Wi-Fi protocols: IEEE 802.11a/b/g/n/ac/ax ● Bluetooth protocol: Bluetooth 5.4 (BLE and SPP) ● All hardware components are fully compliant with EU RoHS directive
Power Supply	VBAT Power Supply: <ul style="list-style-type: none"> ● 3.0–3.6 V ● Typ.: 3.3 V I/O Power Supply: <ul style="list-style-type: none"> ● 3.0–3.6 V ● Typ.: 3.3 V
Temperature Range	<ul style="list-style-type: none"> ● Operating Temperature ¹: -20 to +80 °C ● Storage Temperature: -30 to +85 °C
EVB Kit	FCU760K-TE-A
RF Antenna Interface	
Wi-Fi Antenna Interface	<ul style="list-style-type: none"> ● ANT_WIFI/BT ● 50 Ω impedance
Bluetooth Antenna Interface ²	<ul style="list-style-type: none"> ● ANT_BT (optional) ● 50 Ω impedance
Application Interface	
Wi-Fi/Bluetooth Application Interface	USB 2.0

¹ To meet the normal operating temperature range requirements, it is necessary to ensure effective thermal dissipation, e.g., by adding passive or active heatsinks, heat pipes, vapor chambers, etc. Within this range, the module's indicators comply with IEEE and Bluetooth specification requirements.

² The dedicated Bluetooth antenna interface is optional. For more details, contact Quectel Technical Support.

2.2. Functional Diagram

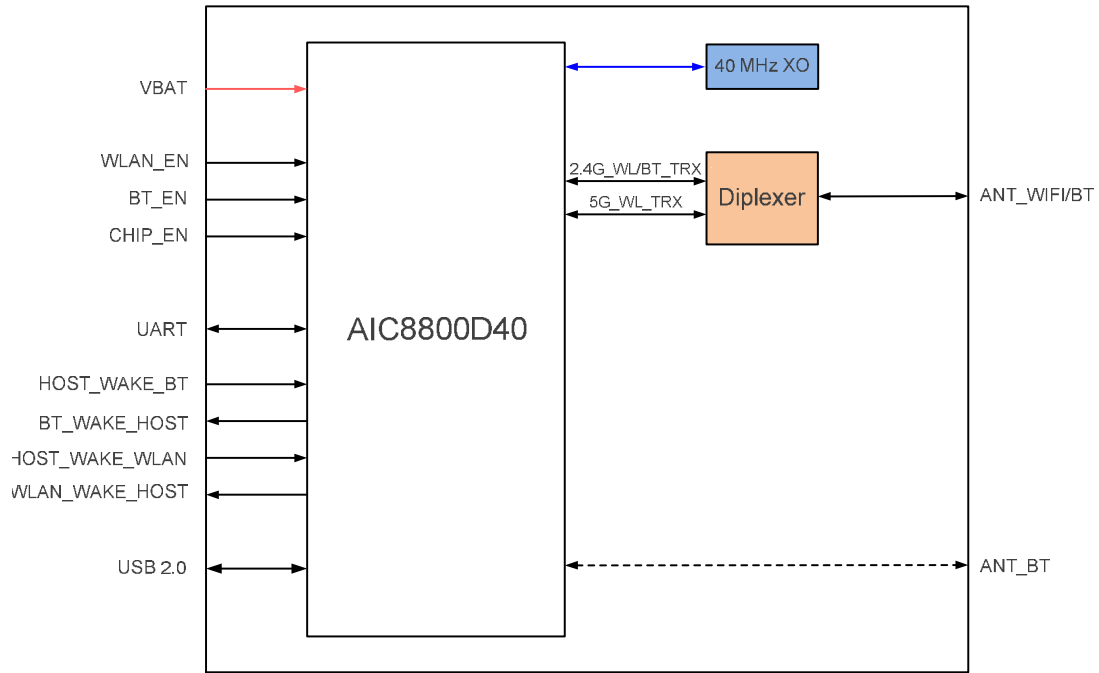

Figure 1: Functional Diagram

NOTE

The function of UART interface is under development.

3 RF Performances

3.1. Wi-Fi Performances

Table 3: Wi-Fi Performances

Operating Frequency			
2.4 GHz: 2.400–2.4835 GHz			
5 GHz: 5.150–5.850 GHz			
Modulation			
DSSS、CCK、BPSK、QPSK、16QAM、64QAM、256QAM、1024QAM			
Operating Mode			
<ul style="list-style-type: none"> ● AP ● STA 			
Transmission Data Rate			
<ul style="list-style-type: none"> ● 802.11b: 1 Mbps, 2 Mbps, 5.5 Mbps, 11 Mbps ● 802.11a/g: 6 Mbps, 9 Mbps, 12 Mbps, 18 Mbps, 24 Mbps, 36 Mbps, 48 Mbps, 54 Mbps ● 802.11n: HT20 (MCS 0–7), HT40 (MCS 0–7) ● 802.11ac: VHT20 (MCS 0–8), VHT40 (MCS 0–9) ● 802.11ax: HT20 (MCS 0–9), HT40 (MCS 0–11) 			
		Unit: dBm, Tolerance: ±2 dB	
Condition	EVM	Unit: dBm, Tolerance: ±2 dB	
		Transmitting Power @ Typ.	Receiving Sensitivity @ Typ.
	≤ 35 %	802.11b @ 1 Mbps	-95
		802.11b @ 11 Mbps	-88
2.4 GHz	≤ -5 dB	802.11g @ 6 Mbps	-93
	≤ -25 dB	802.11g @ 54 Mbps	-77
	≤ -5 dB	802.11n, HT20 @ MCS 0	-93

	802.11n, HT20 @ MCS 7	≤ -27 dB	15	-75
	802.11n, HT40 @ MCS 0	≤ -5 dB	17	-89
	802.11n, HT40 @ MCS 7	≤ -27 dB	15	-71
	802.11ax, HE20 @ MCS 0	≤ -5 dB	17	-92
	802.11ax, HE20 @ MCS 11	≤ -35 dB	13	-65
	802.11ax, HE40 @ MCS 0	≤ -5 dB	17	-91
	802.11ax, HE40 @ MCS 11	≤ -35 dB	13	-60
	802.11a @ 6 Mbps	≤ -5 dB	17	-94
	802.11a @ 54 Mbps	≤ -25 dB	15	-77
	802.11n, HT20 @ MCS 0	≤ -5 dB	17	-93
	802.11n, HT20 @ MCS 7	≤ -27 dB	15	-75
	802.11n, HT40 @ MCS 0	≤ -5 dB	16	-91
	802.11n, HT40 @ MCS 7	≤ -27 dB	14	-72
5 GHz	802.11ac, VHT20 @ MCS 0	≤ -5 dB	16	-94
	802.11ac, VHT20 @ MCS 8	≤ -30 dB	14	-71
	802.11ac, VHT40 @ MCS 0	≤ -5 dB	16	-91
	802.11ac, VHT40 @ MCS 9	≤ -32 dB	14	-66
	802.11ax, HE20 @ MCS 0	≤ -5 dB	16	-94
	802.11ax, HE20 @ MCS 11	≤ -35 dB	12	-66
	802.11ax, HE40 @ MCS 0	≤ -5 dB	16	-91
	802.11ax, HE40 @ MCS 11	≤ -35 dB	12	-62

3.2. Bluetooth Performances

Table 4: Bluetooth Performances

Operating Frequency	
2.400–2.4835 GHz	
Modulation	
GFSK, 8-DPSK, $\pi/4$ -DQPSK	
Operating Mode	
<ul style="list-style-type: none"> ● Classic Bluetooth (BR + EDR) ● Bluetooth Low Energy (BLE) 	
Condition	Unit: dBm, Tolerance: ± 2 dB
	Receiving Sensitivity @ Typ.
BR	-90
EDR ($\pi/4$ -DQPSK)	-92
EDR (8-DPSK)	-85
BLE (1 Mbps)	-93
BLE (2 Mbps)	-91

4 Application Interfaces

4.1. Pin Assignment

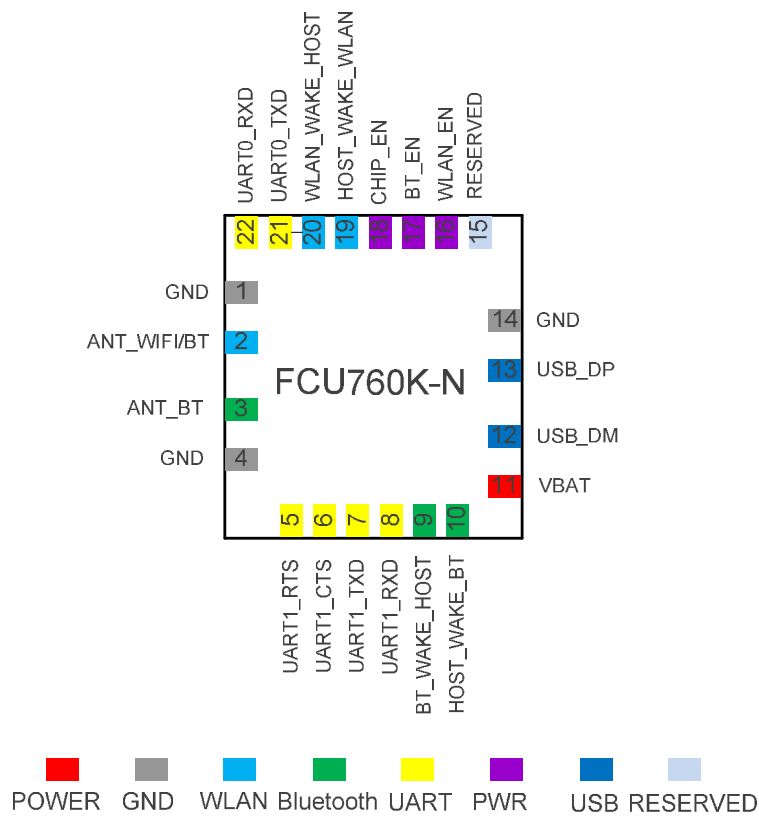

Figure 2: Pin Assignment (Top View)

NOTE

1. Keep all RESERVED or unused pins unconnected.
2. The function of UART interface is under development.

4.2. Pin Description

Table 5: I/O Parameters Definition

Type	Description
AIO	Analog Input/Output
DI	Digital Input
DO	Digital Output
DIO	Digital Input/Output
PI	Power Input

DC characteristics include power domain and rate current.

Table 6: Pin Description

Power Supply					
Pin Name	Pin No.	I/O	Description	DC Characteristics	Comment
VBAT	11	PI	Power supply for the module	Vmin = 3.0 V Vnom = 3.3 V Vmax = 3.6 V	
GND	1, 4, 14				
Wi-Fi Application Interfaces					
Pin Name	Pin No.	I/O	Description	DC Characteristics	Comment
HOST_WAKE_WLAN	19	DI	Host wakes up WLAN	VBAT	
WLAN_WAKE_HOST	20	DO	WLAN wakes up host		
WLAN_EN	16	DI	WLAN enable control		
CHIP_EN	18	DI	CHIP enable		
USB_DM	12	AIO	USB differential data (-)		
USB_DP	13	AIO	USB differential data (+)		

Bluetooth Application Interfaces					
Pin Name	Pin No.	I/O	Description	DC Characteristics	Comment
HOST_WAKE_BT	10	DI	Host wakes up Bluetooth	VBAT	
BT_WAKE_HOST	9	DO	Bluetooth wakes up host		
BT_EN	17	DI	Bluetooth enable control		
CHIP_EN	18	DI	CHIP enable		
USB_DM	12	AIO	USB differential data (-)		
USB_DP	13	AIO	USB differential data (+)		
RF Antenna Interfaces					
Pin Name	Pin No.	I/O	Description	DC Characteristics	Comment
ANT_WIFI/BT	2	AIO	Wi-Fi/Bluetooth antenna interface		50 Ω impedance.
ANT_BT (optional*)	3	AIO	Bluetooth antenna interface		
RESERVED Pin					
Pin Name	Pin No.				Comment
RESERVED	15				Keep it open.

*ANT_BT is not used in FCU760K-N module's CE testing. It's just reserved for client's design.

4.3. Power Supply

The module is powered by VBAT. It is recommended to use a 3.3 V power supply chip with sufficient up to 0.5 A. For better power supply performance, it is recommended to parallel a 47 μF decoupling capacitor, and 1 μF and 100 nF filter capacitors near the module's VBAT pin. In addition, it is recommended to add a TVS near the VBAT to improve the surge voltage bearing capacity of the module. In principle, the longer the VBAT trace is, the wider it should be.

VBAT reference circuit is shown below:

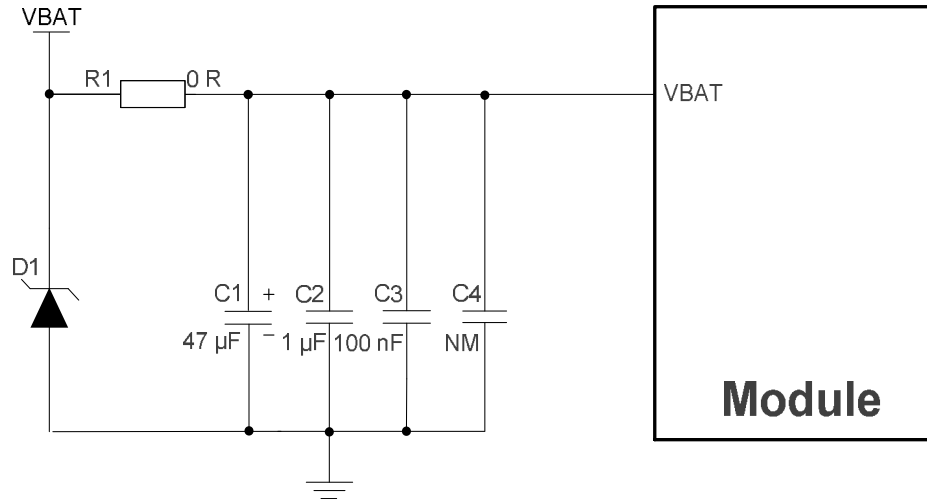

Figure 3: Reference Circuit of Power Supply

The power-up timing of the module is shown below.

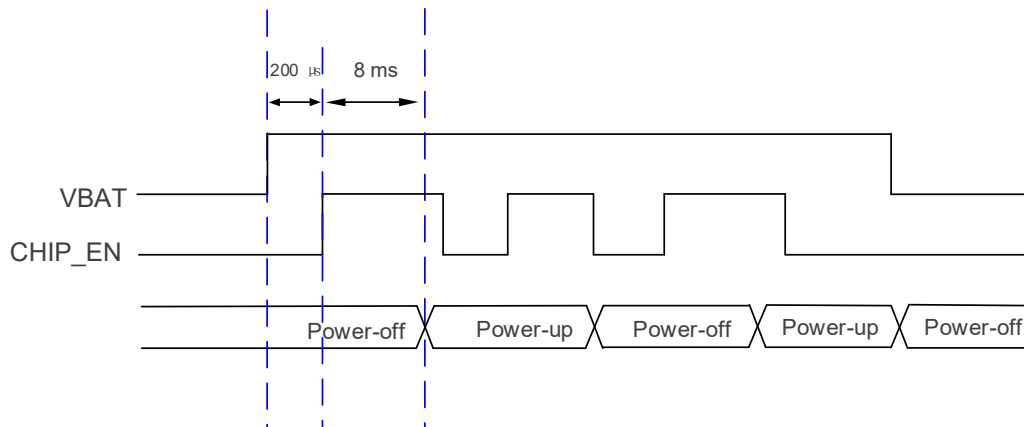

Figure 4: Power-up Timing

4.4. Wi-Fi/Bluetooth Application Interface

The module provides USB 2.0 interface communicating with the host for Wi-Fi/Bluetooth function.

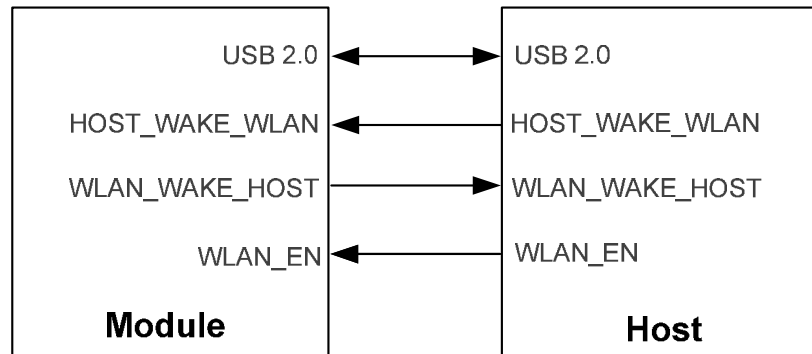

Figure 5: Wi-Fi Application Interface Connection

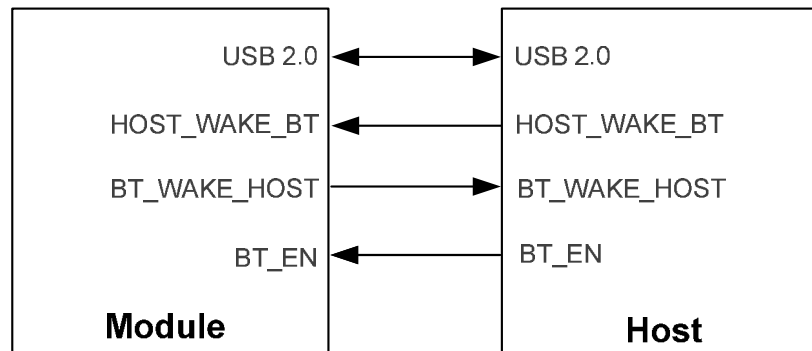

Figure 6: Bluetooth Application Interface Connection

4.4.1. USB Interface

USB interface connection between the module and the host is illustrated in the following figure.

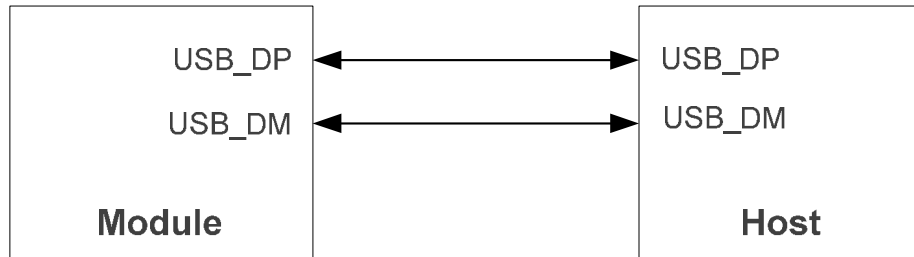

Figure 7: USB Interface Connection

To ensure compliance of interface design with the USB 2.0 specification, it is recommended to adopt the following principles:

- The impedance of USB signal trace is $90 \Omega \pm 10 \%$. Route the USB traces in inner layer of the PCB, and surround the traces with ground on that layer and with ground planes above and below.
- Keep USB signals far away from other sensitive circuits/signals such as RF circuits and analog signals, as well as noise signals such as clock signals and DC-DC signals.
- USB signal traces (USB_DP and USB_DM) need to be equal in length, width and distance (the distance between the traces should be less than 1 mm).
- The distance between USB signal line and other signals must be greater than twice the trace width, and the bus load capacitance must be less than 15 pF.

4.5. RF Antenna Interface

Appropriate antenna type and design should be used with matched antenna parameters according to specific application. It is required to perform a comprehensive functional test for the RF design before mass production of terminal products. The entire content of this chapter is provided for illustration only. Analysis, evaluation and determination are still necessary when designing target products.

The module provides two antenna pins (ANT_WIFI/BT, ANT_BT), among which the ANT_BT is optional for two-antenna module (FCU760K-N). The impedance of antenna port is 50Ω .

Table 7: Antenna Design Requirements

Parameter	Requirement ³
Frequency Ranges (GHz)	<ul style="list-style-type: none"> ● 2.400–2.4835 ● 5.150–5.850
Cable Insertion Loss (dB)	< 1
VSWR	≤ 2 (Typ.)
Gain (dBi)	2.4GHZ : ≤0.73 dBi 5G HZ: ≤ 1.14dBi
Max Input Power (W)	50
Input Impedance (Ω)	50
Polarization Type	Vertical

4.5.1.Reference Design

The module provides one antenna pins. It is recommended to reserve a π-type matching circuit and add ESD protection components for better RF performance. Reserved matching components (R1, C1 and C2) shall be placed as close to the antenna as possible. C1, C2 and D1 are not mounted by default. The parasitic capacitance of TVS should be less than 0.05 pF

The following reference design is based on ANT_WIFI/BT as an example, the reference design of other RF antenna interfaces is the same.

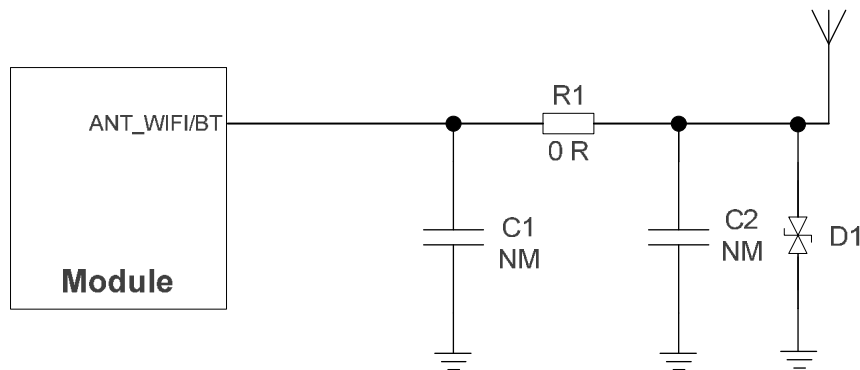

Figure 8: Reference Circuit for RF Antenna Interface

³ For more details about the RF performances, see **Chapter 3**.

4.5.2.RF Routing Guidelines

For user’s PCB, the characteristic impedance of all RF traces should be controlled to 50 Ω. The impedance of the RF traces is usually determined by the trace width (W), the materials’ dielectric constant, the height from the reference ground to the signal layer (H), and the spacing between RF traces and grounds (S). Microstrip or coplanar waveguide is typically used in RF layout to control characteristic impedance. The following are reference designs of microstrip or coplanar waveguide with different PCB structures.

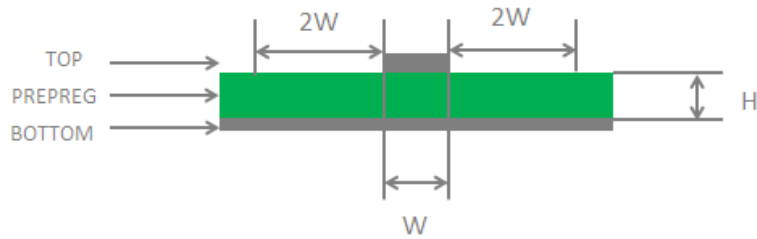

Figure 9: Microstrip Design on a 2-layer PCB

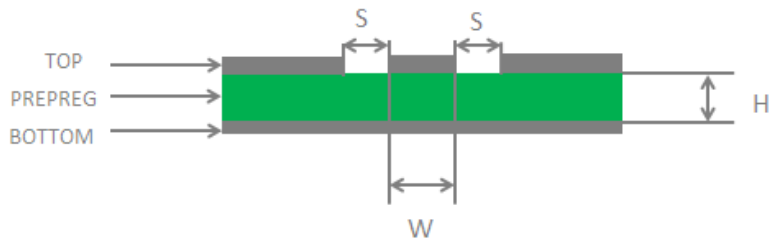

Figure 10: Coplanar Waveguide Design on a 2-layer PCB

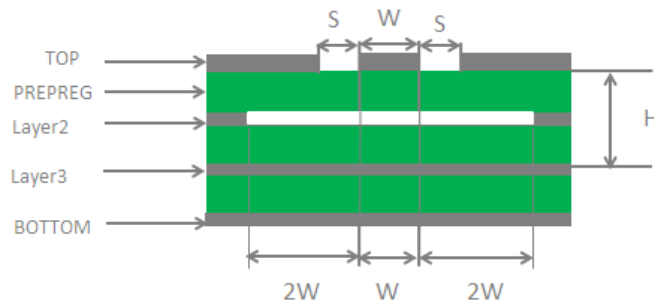

Figure 11: Coplanar Waveguide Design on a 4-layer PCB (Layer 3 as Reference Ground)

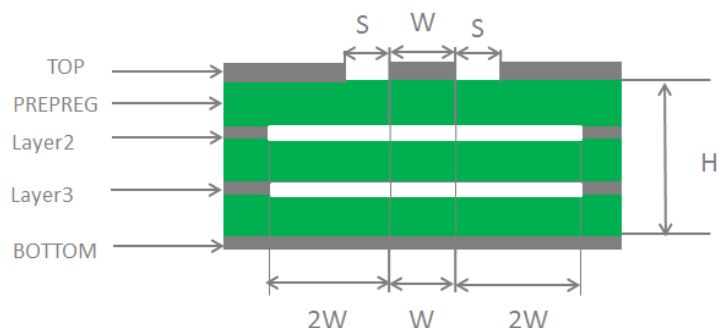

Figure 12: Coplanar Waveguide Design on a 4-layer PCB (Layer 4 as Reference Ground)

To ensure RF performance and reliability, follow the principles below in RF layout design:

- Use an impedance simulation tool to accurately control the characteristic impedance of RF traces to 50Ω .
- The GND pins adjacent to RF pins should not be designed as thermal relief pads, and should be fully connected to ground.
- The distance between the RF pins and the RF connector should be as short as possible and all the right-angle traces should be changed to curved ones. The recommended trace angle is 135° .
- There should be clearance under the signal pin of the antenna connector or solder joint.
- The reference ground of RF traces should be complete. Meanwhile, adding some ground vias around RF traces and the reference ground could help to improve RF performance. The distance between the ground vias and RF traces should be not less than twice the width of RF signal traces ($2 \times W$).
- Keep RF traces away from interference sources, and avoid intersection and paralleling between traces on adjacent layers.

For more details about RF layout, see *document [1]*.

4.5.3. RF Connector Recommendation

If RF connector is used for antenna connection, it is recommended to use the U.FL-R-SMT connector provided by Hirose.

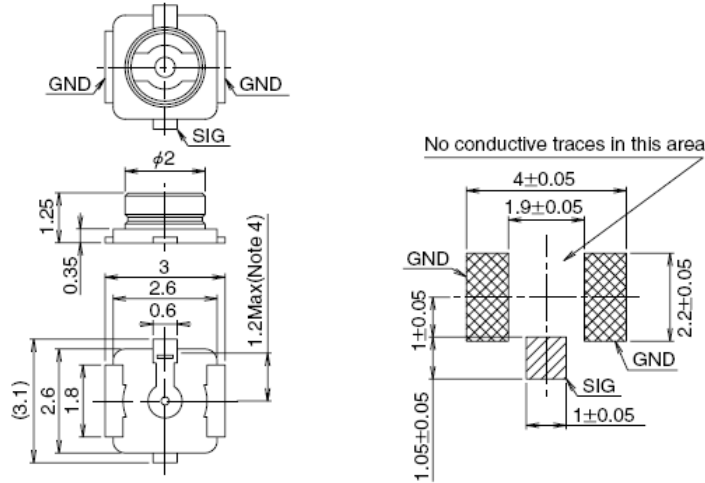

Figure 13: Dimensions of the Receptacle (Unit: mm)

U.FL-LP series mated plugs listed in the following figure can be used to match the U.FL-R-SMT connector.

Part No.	U.FL-LP-040	U.FL-LP-066	U.FL-LP(V)-040	U.FL-LP-062	U.FL-LP-088
Mated Height	2.5mm Max. (2.4mm Nom.)	2.5mm Max. (2.4mm Nom.)	2.0mm Max. (1.9mm Nom.)	2.4mm Max. (2.3mm Nom.)	2.4mm Max. (2.3mm Nom.)
Applicable cable	Dia. 0.81mm Coaxial cable	Dia. 1.13mm and Dia. 1.32mm Coaxial cable	Dia. 0.81mm Coaxial cable	Dia. 1mm Coaxial cable	Dia. 1.37mm Coaxial cable
Weight (mg)	53.7	59.1	34.8	45.5	71.7
RoHS	YES				

Figure 14: Specifications of Mated Plugs

The following figure describes the space factor of mated connectors.

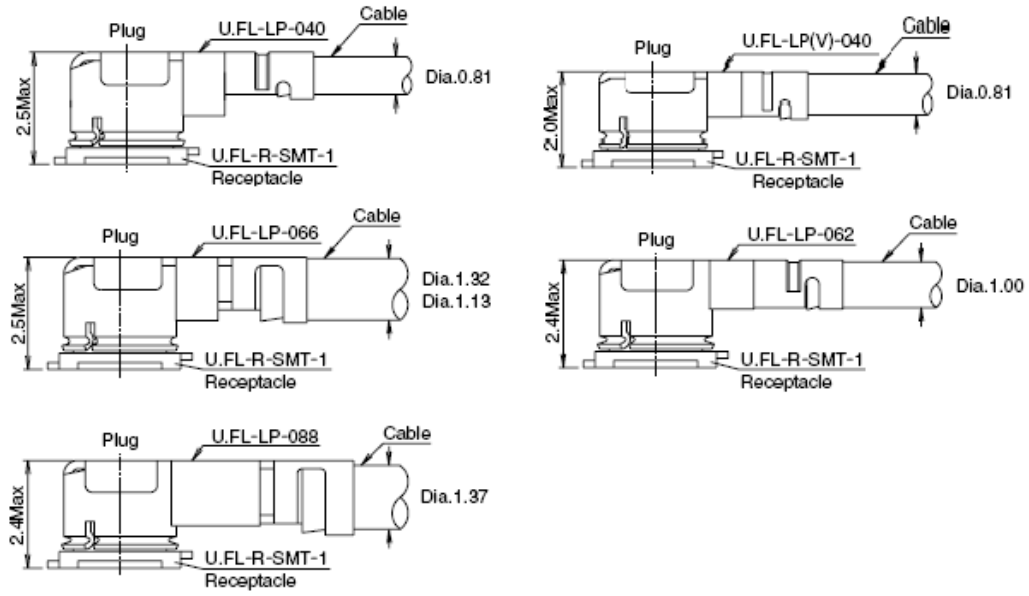

Figure 15: Space Factor of Mated Connectors (Unit: mm)

For more details, please visit <http://www.hirose.com>.

5 Electrical Characteristics & Reliability

5.1. Absolute Maximum Ratings

Table 8: Absolute Maximum Ratings (Unit: V)

Parameter	Min.	Max.
VBAT	-0.3	3.6
Voltage at Digital Pins	-0.3	3.6

5.2. Power Supply Ratings

Table 9: Module Power Supply Ratings (Unit: V)

Parameter	Min.	Typ.	Max.
VBAT	3.0	3.3	3.6

5.3. ESD Protection

Static electricity occurs naturally and it may damage the module. Therefore, applying proper ESD countermeasures and handling methods is imperative. For example, wear anti-static gloves during the development, production, assembly and testing of the module; add ESD protection components to the ESD sensitive interfaces and points in the product design.

Table 10: Electrostatics Discharge Characteristics (Unit: kV)

Model	Test Result	Standard
Human Body Model (HBM)	> ±3	ESDA/JEDEC JS-001-2017
Charged Device Model (CDM)	> ±0.8	ESDA/JEDEC JS-002-2018

5.4. Power Consumption

5.4.1. Wi-Fi Power Consumption

Table 11: Wi-Fi Power Consumption

Protocol	Condition	I _{VDDIO}	I _{VBAT}	Unit	
802.11b	Tx @ 1 Mbps	TBD	304.29	mA	
	Tx @ 11 Mbps	TBD	182.90	mA	
802.11g	Tx @ 6 Mbps	TBD	227.59	mA	
	Tx @ 54 Mbps	TBD	102.51	mA	
2.4 GHz	Tx HT20 @ MCS 0	TBD	298.62	mA	
	Tx HT20 @ MCS 7	TBD	146.71	mA	
	Tx HT40 @ MCS 0	TBD	299.95	mA	
	Tx HT40 @ MCS 7	TBD	149.38	mA	
	Tx HE20 @ MCS 0	TBD	283.82	mA	
	Tx HE20 @ MCS11	TBD	110.47	mA	
	Tx HE40 @ MCS 0	TBD	290.06	mA	
	Tx HE40 @ MCS11	TBD	114.51	mA	
	5 GHz 802.11a	Tx @ 6 Mbps	TBD	241.96	mA
		Tx @ 54 Mbps	TBD	115.55	mA

802.11n	Tx HT20 @ MCS 0	TBD	306.54	mA
	Tx HT20 @ MCS 7	TBD	164.02	mA
	Tx HT40 @ MCS 0	TBD	276.46	mA
	Tx HT40 @ MCS 7	TBD	135.03	mA
802.11ac	Tx VHT20 @ MCS 0	TBD	306.35	mA
	Tx VHT20 @ MCS 8	TBD	148.78	mA
	Tx VHT40 @ MCS 0	TBD	310.60	mA
	Tx VHT40 @ MCS 9	TBD	146.03	mA
802.11ax	Tx HE20 @ MCS 0	TBD	295.42	mA
	Tx HE20 @ MCS 11	TBD	123.50	mA
	Tx HE40 @ MCS 0	TBD	300.95	mA
	Tx HE40 @ MCS 11	TBD	126.69	mA

5.4.2. Bluetooth Power Consumption

Table 12: Bluetooth Power Consumption in Non-signalling Modes

Mode	Transmitting Power	I _{VDDIO}	I _{VBAT}
BR	5.46	TBD	94.46
	5.55	TBD	94.47
	5.05	TBD	94.54
EDR ($\pi/4$ -DQPSK)	2.01	TBD	85.84
	1.58	TBD	85.96
EDR (8-DPSK)	2.06	TBD	85.93
	1.60	TBD	86.10
BLE (1 Mbps)	5.55	TBD	101.59
	5.05	TBD	101.73

BLE (2 Mbps)	5.54	TBD	75.57
	5.06	TBD	75.69

5.5. Digital I/O Characteristics

Table 13: Digital I/O Characteristics (Unit: V)

Parameter	Description	Min.	Max.
V _{IH}	High-level Input Voltage	0.7 × V _{BAT}	V _{BAT}
V _{IL}	Low-level Input Voltage	0	0.3 × V _{BAT}
V _{OH}	High-level Output Voltage	TBD	TBD
V _{OL}	Low-level Output Voltage	TBD	TBD

5.6. Thermal Dissipation

The module offers the best performance when all internal IC chips are working within their operating temperatures. When the IC chip reaches or exceeds the maximum junction temperature, the module may still work but the performance and function (such as RF output power, data rate, etc.) will be affected to a certain extent. Therefore, the thermal design should be maximally optimized to ensure all internal IC chips always work within the recommended operating temperature range.

The following principles for thermal consideration are provided for reference:

- Keep the module away from heat sources on your PCB, especially high-power components such as processor, power amplifier, and power supply.
- Maintain the integrity of the PCB copper layer and drill as many thermal vias as possible.
- Follow the principles below when the heatsink is necessary:
 - Do not place large size components in the area where the module is mounted on your PCB to reserve enough place for heatsink installation.
 - Attach the heatsink to the shielding cover of the module; In general, the base plate area of the heatsink should be larger than the module area to cover the module completely;
 - Choose the heatsink with adequate fins to dissipate heat;
 - Choose a TIM (Thermal Interface Material) with high thermal conductivity, good softness and good wettability and place it between the heatsink and the module;

- Fasten the heatsink with four screws to ensure that it is in close contact with the module to prevent the heatsink from falling off during the drop, vibration test, or transportation.

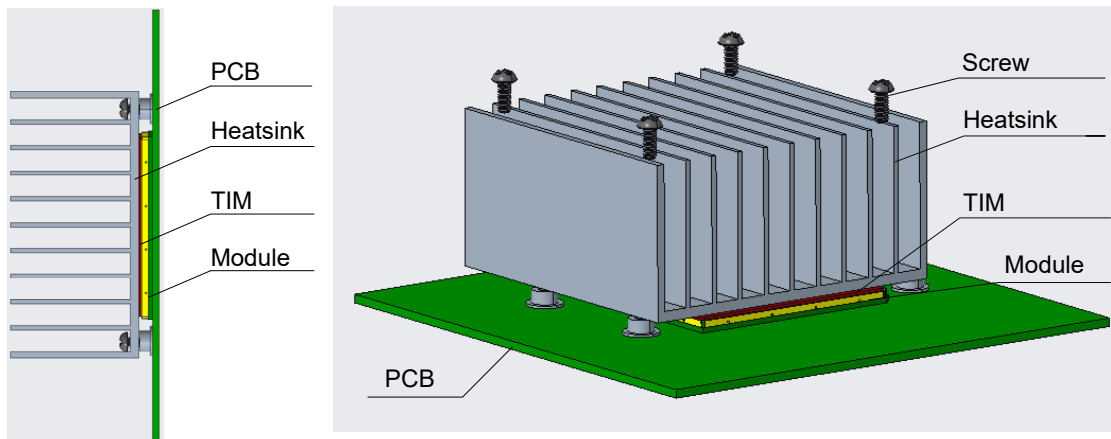

Figure 16: Placement and Fixing of the Heatsink

6 Mechanical Information

This chapter describes the mechanical dimensions of the module. All dimensions are measured in millimeter (mm), and the dimensional tolerances are ± 0.2 mm unless otherwise specified.

6.1. Mechanical Dimensions

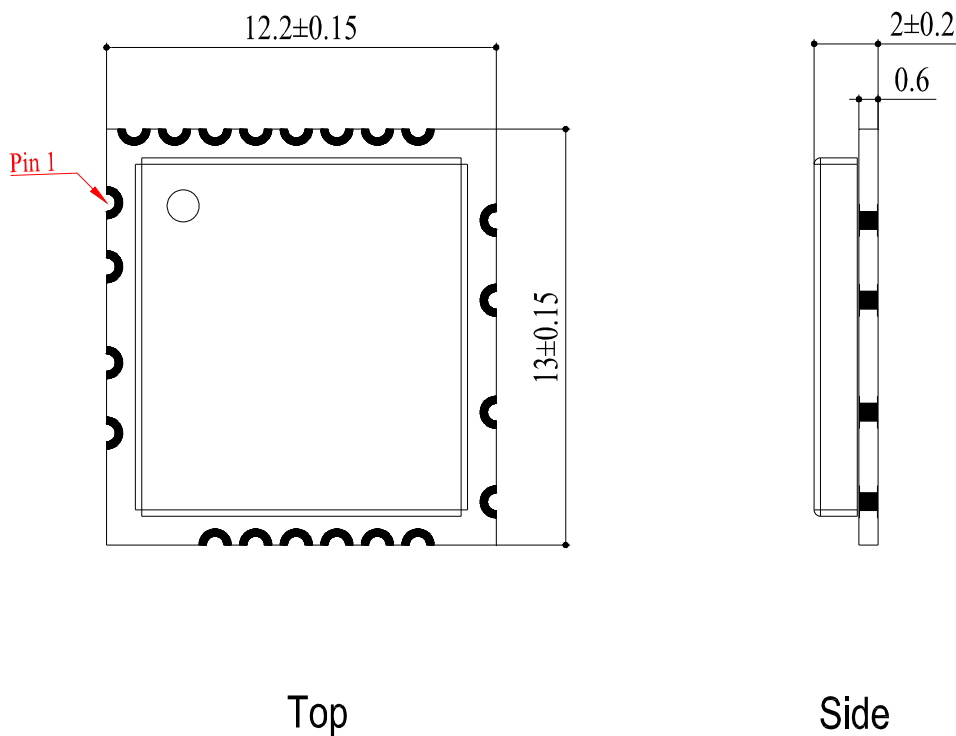

Figure 17: Top and Side Dimensions

NOTE

The package warpage level of the module conforms to *JEITA ED-7306* standard.

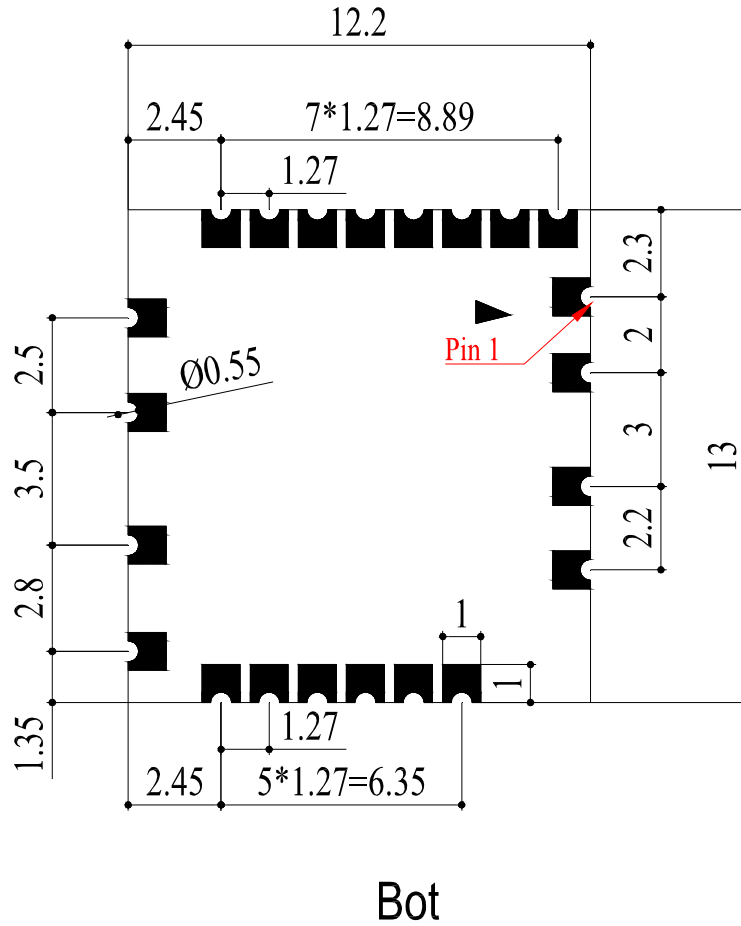

Figure 18: Bottom Dimension (Bottom View)

NOTE

The package warpage level of the module conforms to JEITA ED-7306 standard.

6.2. Recommended Footprint

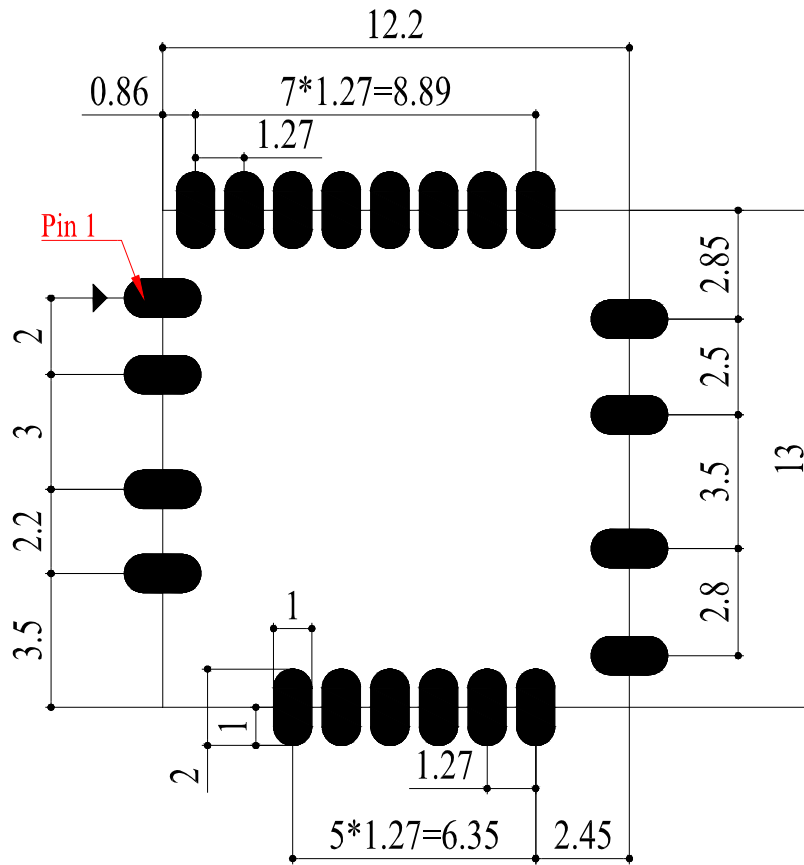

Figure 19: Recommended Footprint

NOTE

Keep at least 3 mm between the module and other components on the motherboard to improve soldering quality and maintenance convenience.

6.3. Top and Bottom Views

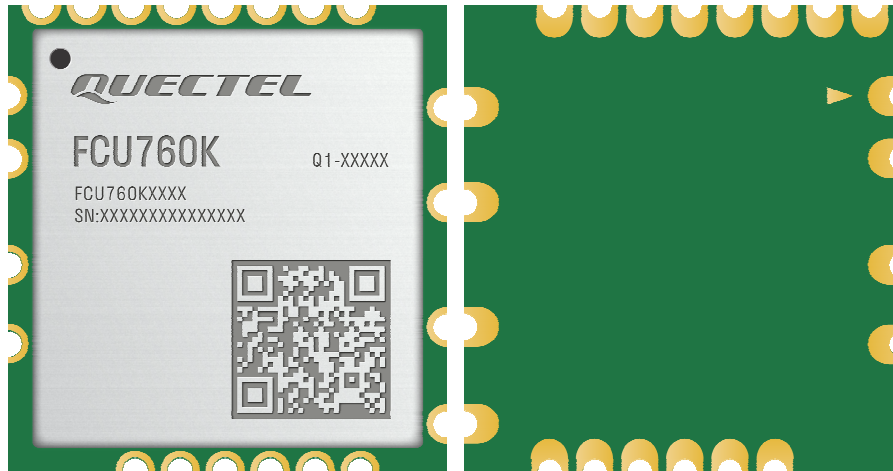

Figure 20: Top and Bottom Views

NOTE

Images above are for illustrative purposes only and may differ from the actual module. For authentic appearance and label, please refer to the module received from Quectel.

7 Storage, Manufacturing & Packaging

7.1. Storage Conditions

The module is provided with vacuum-sealed packaging. MSL of the module is rated as 3. The storage requirements are shown below.

1. Recommended Storage Condition: the temperature should be 23 ± 5 °C and the relative humidity should be 35–60 %.
2. Shelf life (in a vacuum-sealed packaging): 12 months in Recommended Storage Condition.
3. Floor life: 168 hours ⁴ in a factory where the temperature is 23 ± 5 °C and relative humidity is below 60 %. After the vacuum-sealed packaging is removed, the module must be processed in reflow soldering or other high-temperature operations within 168 hours. Otherwise, the module should be stored in an environment where the relative humidity is less than 10 % (e.g., a dry cabinet).
4. The module should be pre-baked to avoid blistering, cracks and inner-layer separation in PCB under the following circumstances:
 - The module is not stored in Recommended Storage Condition;
 - Violation of the third requirement mentioned above;
 - Vacuum-sealed packaging is broken, or the packaging has been removed for over 24 hours;
 - Before module repairing.
5. If needed, the pre-baking should follow the requirements below:
 - The module should be baked for 8 hours at 120 ± 5 °C;
 - The module must be soldered to PCB within 24 hours after the baking, otherwise it should be put in a dry environment such as in a dry cabinet.

⁴ This floor life is only applicable when the environment conforms to IPC/JEDEC J-STD-033. It is recommended to start the solder reflow process within 24 hours after the package is removed if the temperature and moisture do not conform to, or are not sure to conform to *IPC/JEDEC J-STD-033*. Do not unpack the modules in large quantities until they are ready for soldering.

NOTE

1. To avoid blistering, layer separation and other soldering issues, extended exposure of the module to the air is forbidden.
2. Take out the module from the package and put it on high-temperature-resistant fixtures before baking. If shorter baking time is desired, see *IPC/JEDEC J-STD-033* for the baking procedure.
3. Pay attention to ESD protection, such as wearing anti-static gloves, when touching the modules.

7.2. Manufacturing and Soldering

Push the squeegee to apply the solder paste on the surface of stencil, thus making the paste fill the stencil openings and then penetrate to the PCB. Apply proper force on the squeegee to produce a clean stencil surface on a single pass. To guarantee module soldering quality, the thickness of stencil for the module is recommended to be 0.15–0.18 mm. For more details, see **document [2]**.

The recommended peak reflow temperature should be 235–246 °C, with 246 °C as the absolute maximum reflow temperature. To avoid damage to the module caused by repeated heating, it is recommended that the module should be mounted only after reflow soldering for the other side of PCB has been completed. The recommended reflow soldering thermal profile (lead-free reflow soldering) and related parameters are shown below.

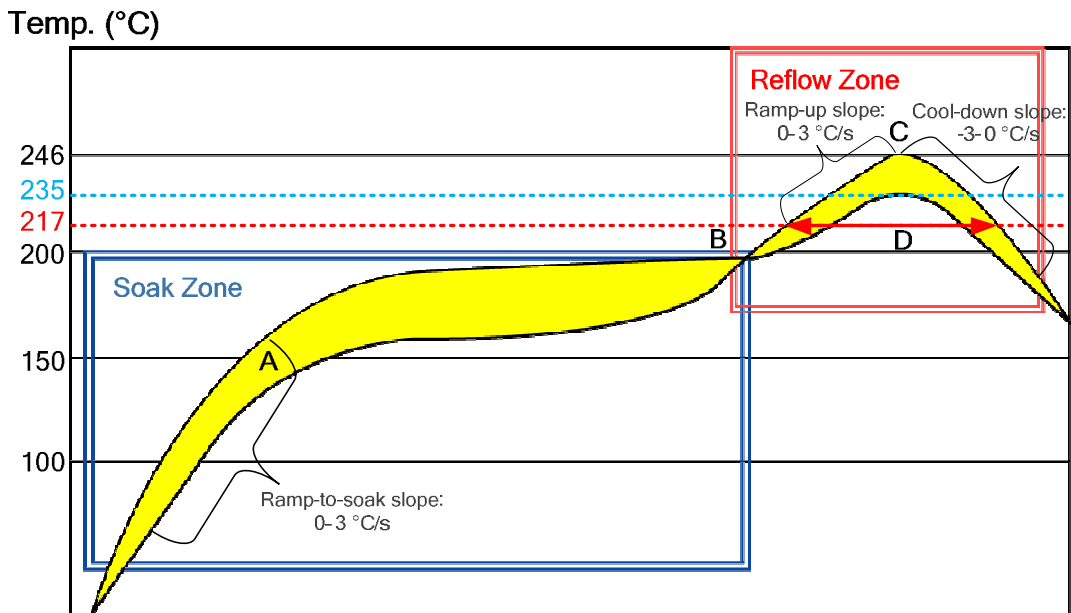

Figure 21: Recommended Reflow Soldering Thermal Profile

Table 14: Recommended Thermal Profile Parameters

Factor	Recommended Value
Soak Zone	
Ramp-to-soak slope	0–3 °C/s
Soak time (between A and B: 150 °C and 200 °C)	70–120 s
Reflow Zone	
Ramp-up slope	0–3 °C/s
Reflow time (D: over 217°C)	40–70 s
Max temperature	235–246 °C
Cool-down slope	-3–0 °C/s
Reflow Cycle	
Max reflow cycle	1

NOTE

1. The above profile parameter requirements are for the measured temperature of the solder joints. Both the hottest and coldest spots of solder joints on the PCB should meet the above requirements.
2. During manufacturing and soldering, or any other processes that may contact the module directly, NEVER wipe the module’s shielding can with organic solvents, such as acetone, ethyl alcohol, isopropyl alcohol, trichloroethylene, etc. Otherwise, the shielding can may become rusted.
3. The shielding can for the module is made of Cupro-Nickel base material. It is tested that after 12 hours’ Neutral Salt Spray test, the laser engraved label information on the shielding can is still clearly identifiable and the QR code is still readable, although white rust may be found.
4. If a conformal coating is necessary for the module, do NOT use any coating material that may chemically react with the PCB or shielding cover, and prevent the coating material from flowing into the module.
5. Avoid using ultrasonic technology for module cleaning since it can damage crystals inside the module.
6. Due to the complexity of the SMT process, please contact Quectel Technical Support in advance for any situation that you are not sure about, or any process (e.g. selective soldering, ultrasonic soldering) that is not mentioned in **document [2]**.

7.3. Packaging Specifications

This chapter describes only the key parameters and process of packaging. All figures below are for reference only. The appearance and structure of the packaging materials are subject to the actual delivery.

The module adopts carrier tape packaging and details are as follow:

7.3.1. Carrier Tape

Dimension details are as follow:

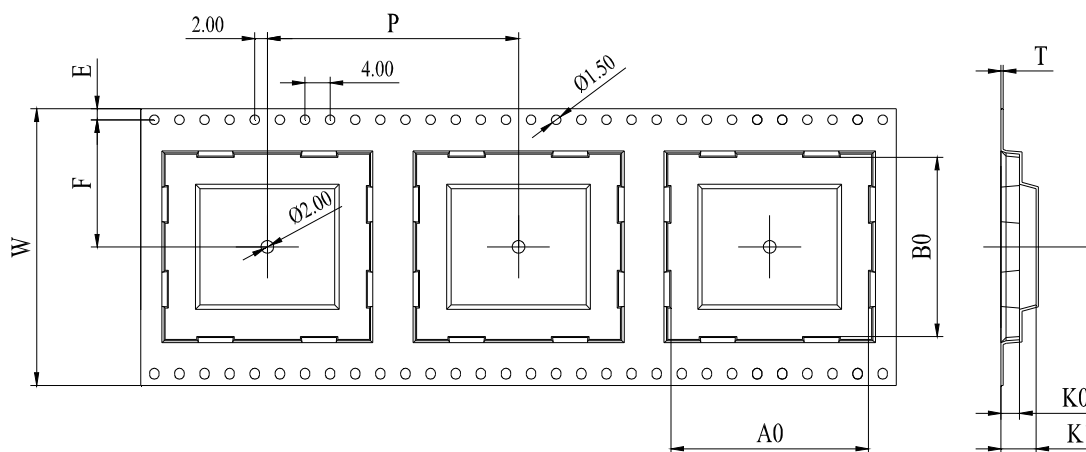

Figure 22: Carrier Tape Dimension Drawing

Table 15: Carrier Tape Dimension Table (Unit: mm)

W	P	T	A0	B0	K0	K1	F	E
32	20	0.4	12.6	13.4	2.55	5.9	14.2	1.75

7.3.2. Plastic Reel

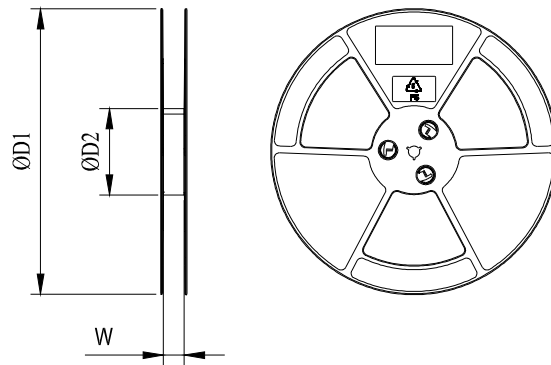

Figure 23: Plastic Reel Dimension Drawing

Table 16: Plastic Reel Dimension Table (Unit: mm)

ØD1	ØD2	W
330	100	32.5

7.3.3. Mounting Direction

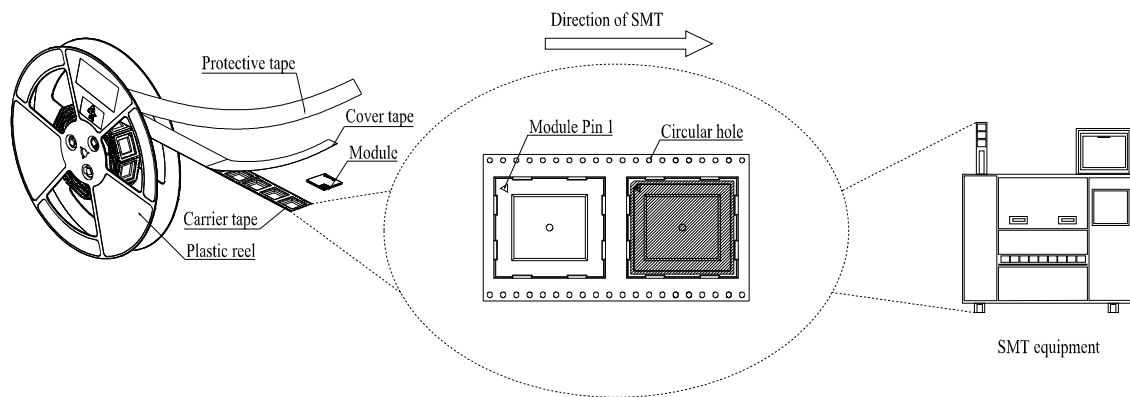
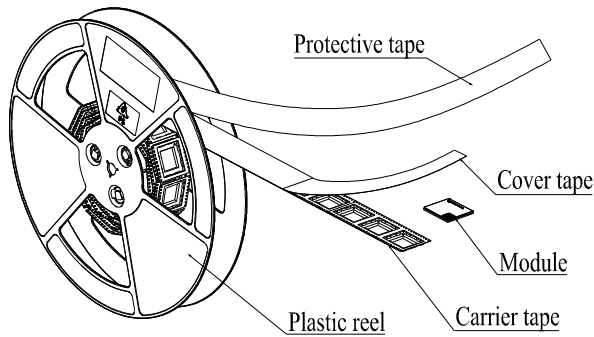

Figure 24: Mounting Direction

7.3.4. Packaging Process



Place the module into the carrier tape and use the cover tape to cover it; then wind the heat-sealed carrier tape to the plastic reel and use the protective tape for protection. 1 plastic reel can load 500 modules.

Place the packaged plastic reel, 1 humidity indicator card and 1 desiccant bag into a vacuum bag, vacuumize it.

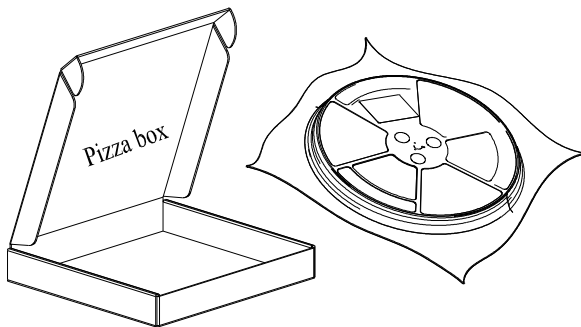
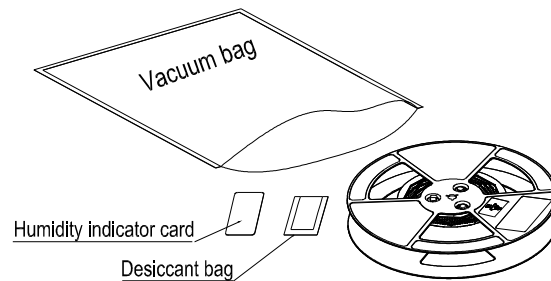

Place the vacuum-packed plastic reel into the pizza box.

Put 4 packaged pizza boxes into 1 carton box and seal it. 1 carton box can pack 2000 modules.

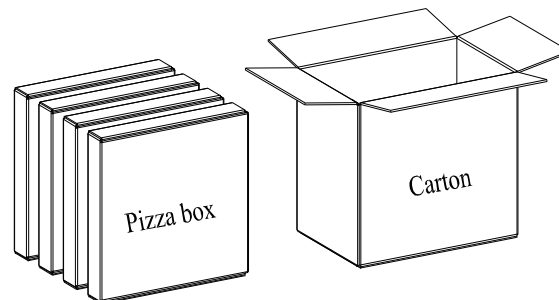

Figure 25: Packaging Process

8 Appendix References

Table 17: Related Documents

Document Name
[1] Quectel_RF_Layout_Application_Note
[2] Quectel_Module_SMT_Application_Note

Table 18: Terms and Abbreviations

Abbreviation	Description
AP	Access Point
BLE	Bluetooth Low Energy
BPSK	Binary Phase Shift Keying
BR	Basic Rate
CCK	Complementary Code Keying
DPSK	Differential Phase Shift Keying
DQPSK	Differential Quadrature Phase Shift Keying
DSSS	Direct Sequence Spread Spectrum
EDR	Enhanced Data Rate
ESD	Electrostatic Discharge
EVM	Error Vector Magnitude
GFSK	Gauss frequency Shift Keying
GND	Ground

HE	High Efficiency
HT	High Throughput
IEEE	Institute of Electrical and Electronics Engineers
I/O	Input/Output
Mbps	Million Bits Per Second
MCS	Modulation and Coding Scheme
MSL	Moisture Sensitivity Levels
PCB	Printed Circuit Board
QAM	Quadrature Amplitude Modulation
QPSK	Quadrature Phase Shift Keying
RoHS	Restriction of Hazardous Substances
SPP	Serial Port Profile
STA	Station
Rx	Receive
RXD	Receive Data
TBD	To Be Determined
TVS	Transient Voltage Suppressor
Tx	Transmit
TXD	Transmit Data
UART	Universal Asynchronous Receiver/Transmitter
USB	Universal Serial Bus
VBAT	Voltage at Battery (Pin)
VHT	Very High Throughput
V _{IH}	High-level Input Voltage
V _{IL}	Low-level Input Voltage

V _{max}	Maximum Voltage
V _{min}	Minimum Voltage
V _{nom}	Normal Voltage
V _{OH}	High-level Output Voltage
V _{OL}	Low-level Output Voltage
V _{SWR}	Voltage Standing Wave Ratio
Wi-Fi	Wireless Fidelity

FCC Certification Requirements.

According to the definition of mobile and fixed device is described in Part 2.1091(b), this device is a mobile device.

And the following conditions must be met:

1. This Modular Approval is limited to OEM installation for mobile and fixed applications only. The antenna installation and operating configurations of this transmitter, including any applicable source-based time-averaging duty factor, antenna gain and cable loss must satisfy MPE categorical Exclusion Requirements of 2.1091.

2. The EUT is a mobile device; maintain at least a 20 cm separation between the EUT and the user's body and must not transmit simultaneously with any other antenna or transmitter.

3. A label with the following statements must be attached to the host end product: This device contains FCC ID: XMR2023FCU760KN.

4. To comply with FCC regulations limiting both maximum RF output power and human exposure to RF radiation, maximum antenna gain (including cable loss) must not exceed:

- Bluetooth/Bluetooth LE/Wi-Fi 2.4G: ≤ -0.1 dBi
- U-NII-1: ≤ -0.9 dBi
 - U-NII-2A: ≤ -1.4 dBi
 - U-NII-2C: ≤ -0.3 dBi
 - U-NII-3: ≤ 0.4 dBi

5. This module must not transmit simultaneously with any other antenna or transmitter

6. The host end product must include a user manual that clearly defines operating requirements and conditions that must be observed to ensure compliance with current FCC RF exposure guidelines.

For portable devices, in addition to the conditions 3 through 6 described above, a separate approval is required to satisfy the SAR requirements of FCC Part 2.1093

If the device is used for other equipment that separate approval is required for all other operating configurations, including portable configurations with respect to 2.1093 and different antenna configurations.

For this device, OEM integrators must be provided with labeling instructions of finished products. Please refer to KDB784748 D01 v07, section 8. Page 6/7 last two paragraphs:

A certified modular has the option to use a permanently affixed label, or an electronic label. For a permanently affixed label, the module must be labeled with an FCC ID - Section 2.926 (see 2.2 Certification (labeling requirements) above). The OEM manual must provide clear instructions explaining to the OEM the labeling requirements, options and OEM user manual instructions that are required (see next paragraph).

For a host using a certified modular with a standard fixed label, if (1) the module's FCC ID is not visible when installed in the host, or (2) if the host is marketed so that end users do not have straightforward commonly used methods for access to remove the module so that the FCC ID of the module is visible; then an additional permanent label referring to the enclosed module: "Contains Transmitter Module FCC ID: XMR2023FCU760KN." or "Contains FCC ID: XMR2023FCU760KN." must be used. The host OEM user manual must also contain clear instructions on how end users can find and/or access the module and the FCC ID.

The final host / module combination may also need to be evaluated against the FCC Part 15B criteria for unintentional radiators in order to be properly authorized for operation as a Part 15 digital device.

The user's manual or instruction manual for an intentional or unintentional radiator shall caution the user

that changes or modifications not expressly approved by the party responsible for compliance could void the user's authority to operate the equipment. In cases where the manual is provided only in a form other than paper, such as on a computer disk or over the Internet, the information required by this section may be included in the manual in that alternative form, provided the user can reasonably be expected to have the capability to access information in that form.

This device complies with part 15 of the FCC Rules. Operation is subject to the following two conditions: (1) This device may not cause harmful interference, and (2) this device must accept any interference received, including interference that may cause undesired operation.

Changes or modifications not expressly approved by the manufacturer could void the user's authority to operate the equipment.

IC Certification Requirements.

This device contains licence-exempt transmitter(s)/receiver(s) that comply with Innovation, Science and Economic Development Canada's licence-exempt RSS(s). Operation is subject to the following two conditions:

1. This device may not cause interference.
2. This device must accept any interference, including interference that may cause undesired operation of the device.

To comply with IC regulations limiting both maximum RF output power and human exposure to RF radiation, maximum antenna gain (including cable loss) must not exceed:

- ❑ Bluetooth/Bluetooth LE/Wi-Fi 2.4G: ≤ -0.1 dBi
- ❑ U-NII-1: ≤ -0.9 dBi
 - U-NII-2A: ≤ -1.4 dBi
 - U-NII-2C: ≤ -0.3 dBi
 - U-NII-3: ≤ 0.4 dBi

L'appareil contient un émetteur / récepteur exempté de licence conforme au CNR exempté de licence d'innovation, sciences et développement économique Canada. Les opérations sont soumises aux deux conditions suivantes:

1. Cet appareil peut ne pas causer d'interférence.

L'appareil doit accepter toute interférence, y compris celles qui peuvent entraîner un fonctionnement indésirable de l'appareil.

This equipment complies with ISED radiation exposure limits set forth for an uncontrolled environment. To comply with RSS-102 RF Exposure compliance requirements, this grant is applicable to only Mobile Configurations. The antennas used for the transmitter must be installed to provide a separation distance of at least 20cm from all persons and must not be co-located or operating in conjunction with any other antenna or transmitter.

The host product shall be properly labelled to identify the modules within the host product.

The Innovation, Science and Economic Development Canada certification label of a module shall be clearly visible at all times when installed in the host product; otherwise, the host product must be labeled to display the Innovation, Science and Economic Development Canada certification number for the module, preceded by the word “Contains” or similar wording expressing the same meaning, as follows: “Contains IC: 10224A-023FCU760KN” or “where: 10224A-023FCU760KN is the module’s certification number” .