

Tx. Spurious 802.11n (HT20) 2462MHz Ref

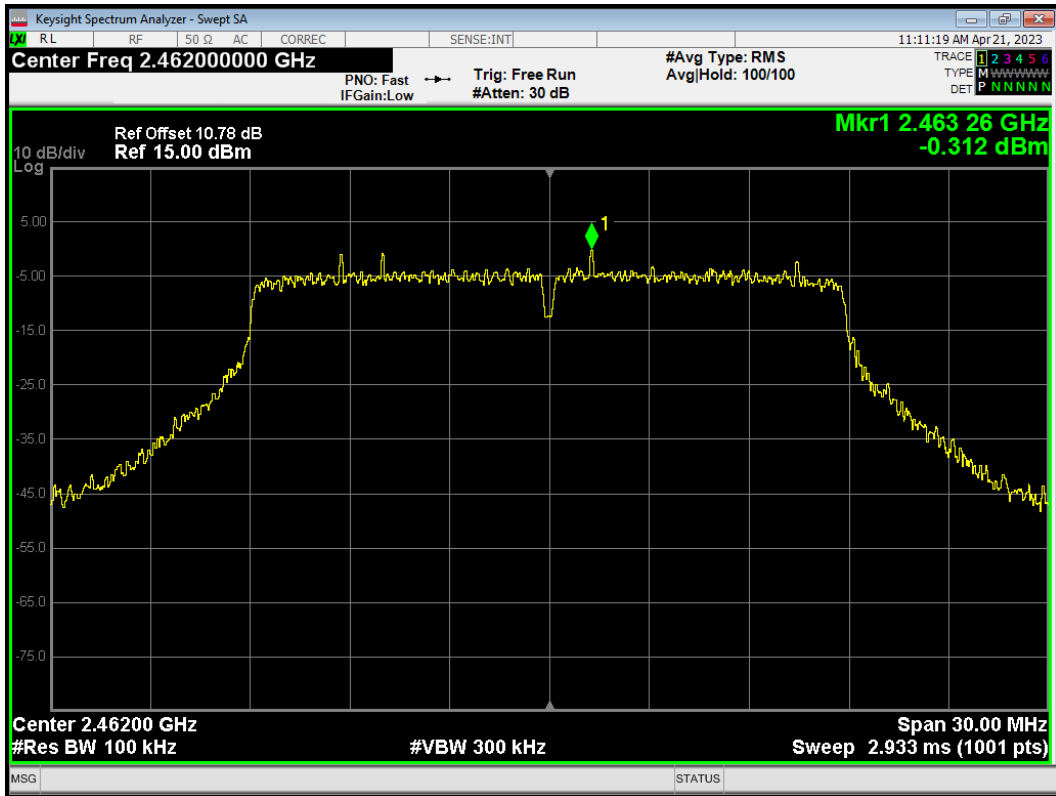

Tx. Spurious 802.11n (HT20) 2462MHz Emission

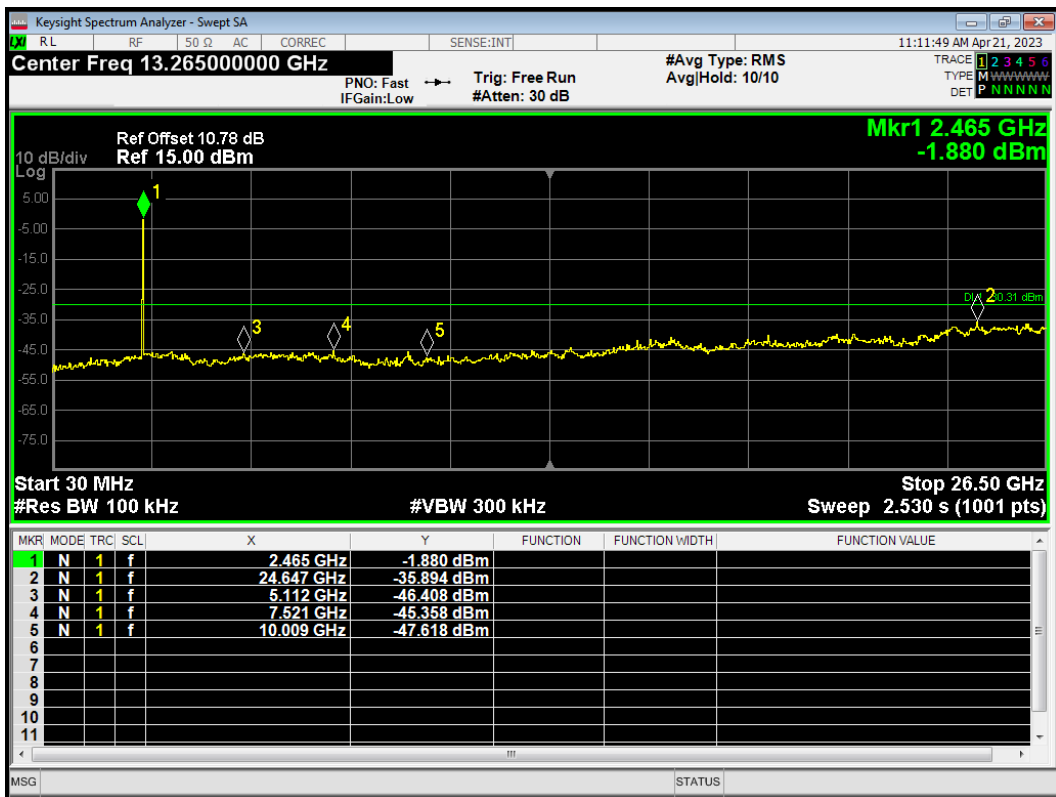

Tx. Spurious 802.11n (HT40) 2422MHz Ref

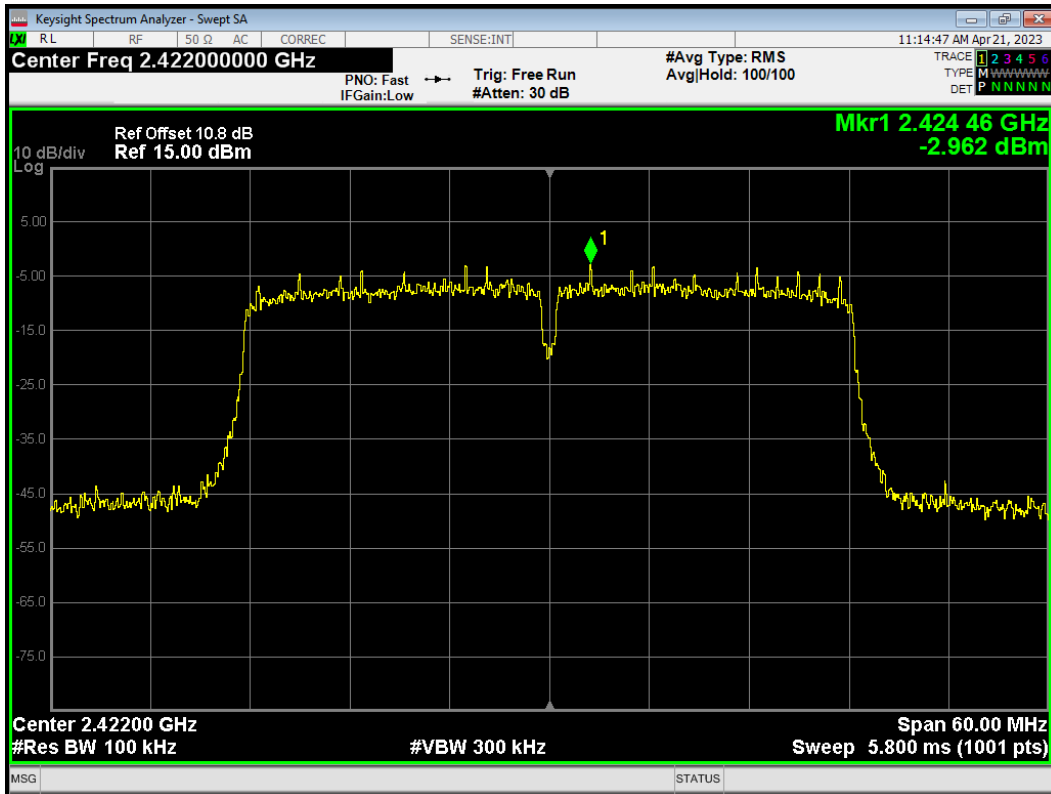

Tx. Spurious 802.11n (HT40) 2422MHz Emission

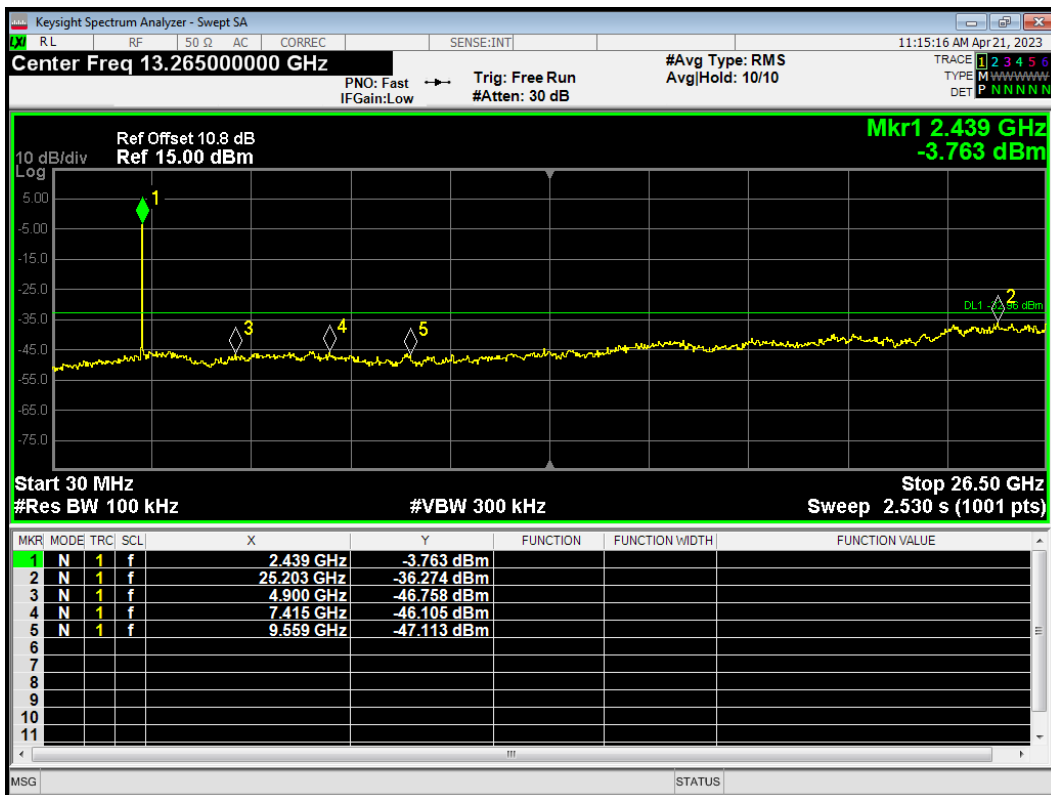

Tx. Spurious 802.11n (HT40) 2427MHz Ref

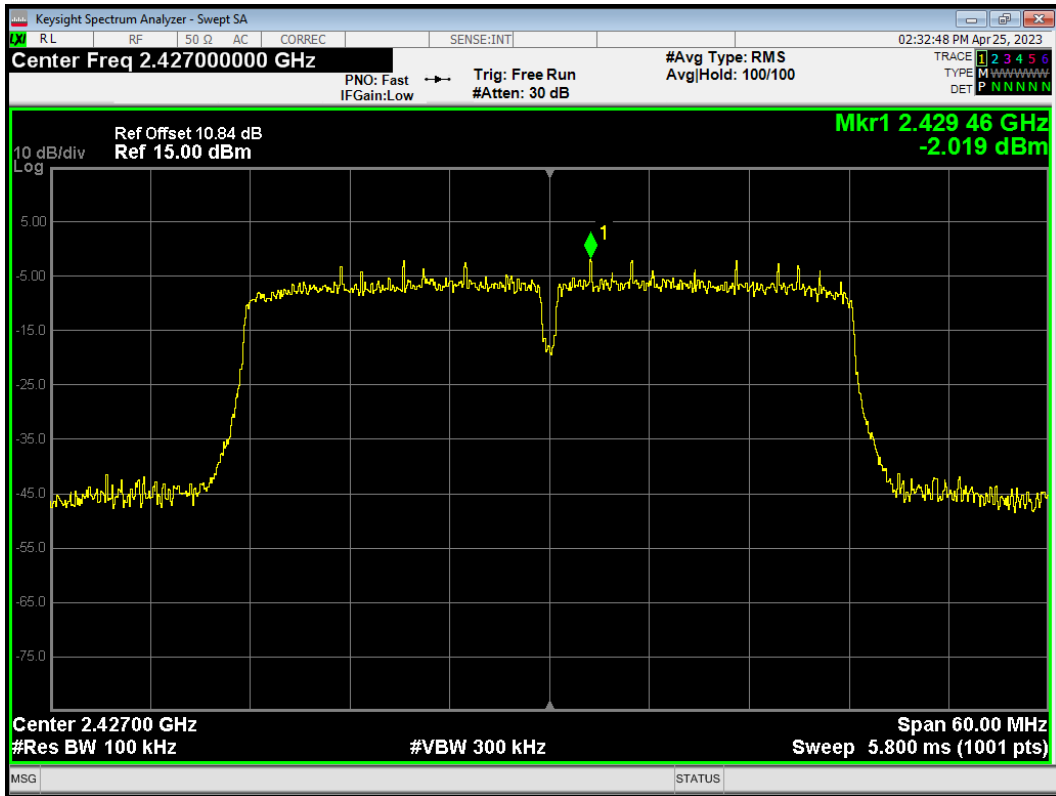

Tx. Spurious 802.11n (HT40) 2427MHz Emission

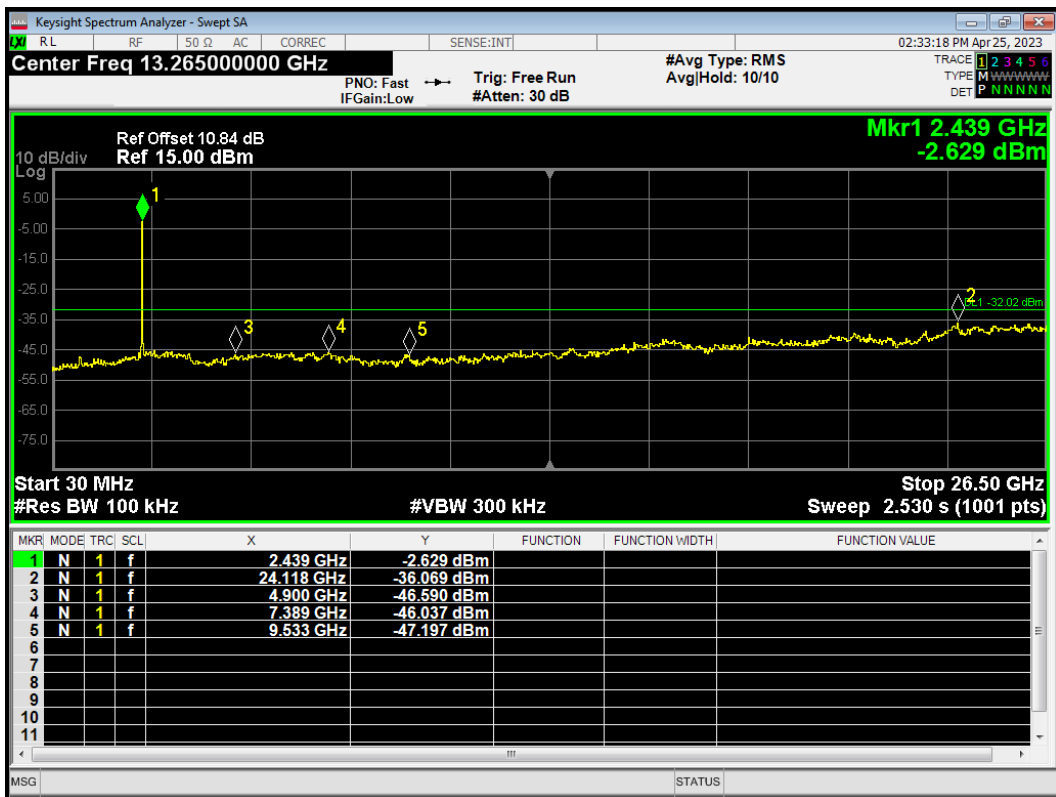

Tx. Spurious 802.11n (HT40) 2432MHz Ref

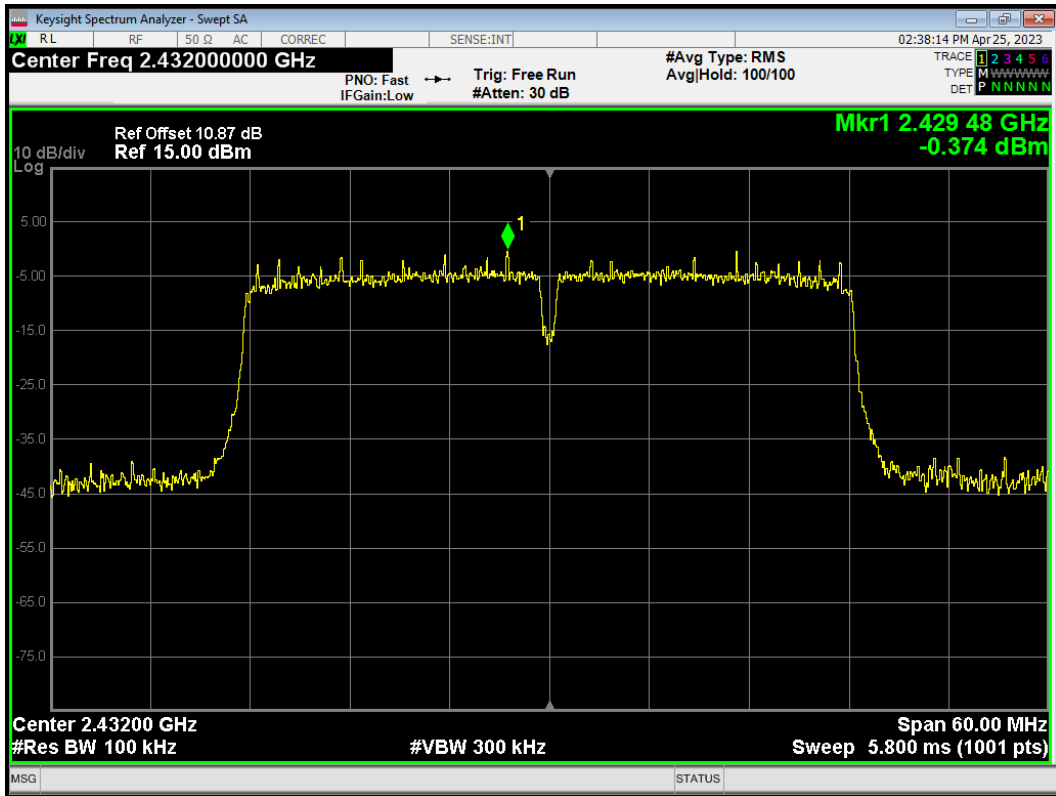

Tx. Spurious 802.11n (HT40) 2432MHz Emission

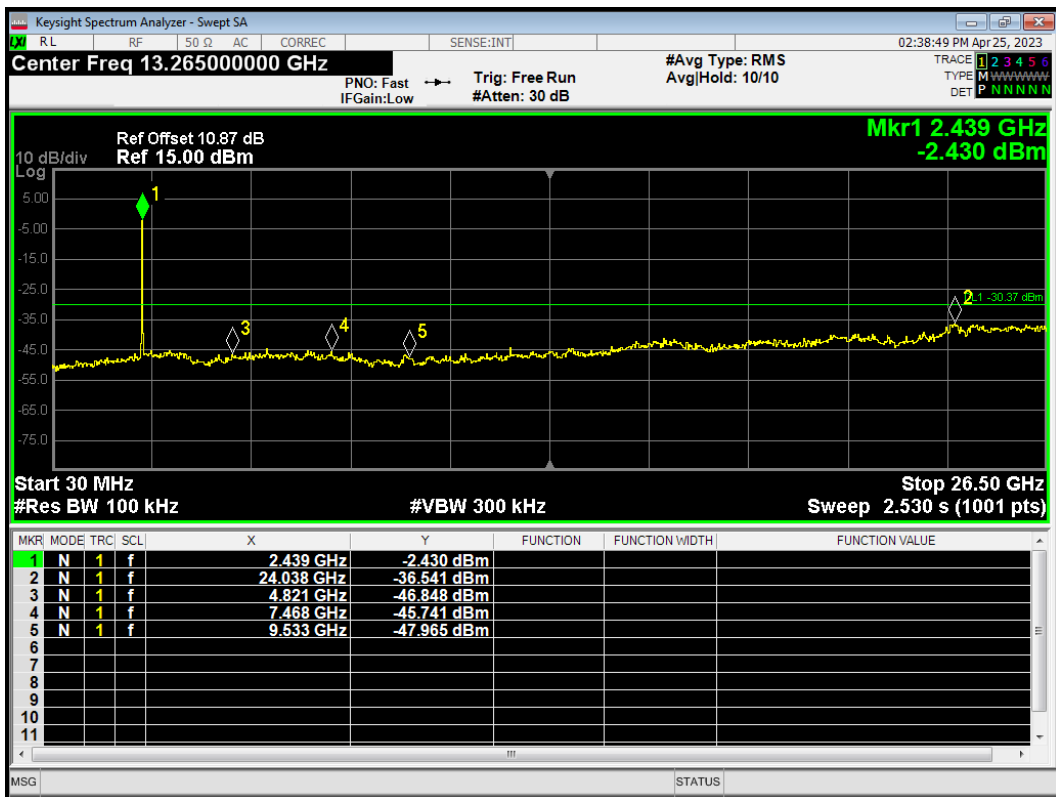

Tx. Spurious 802.11n (HT40) 2437MHz Ref

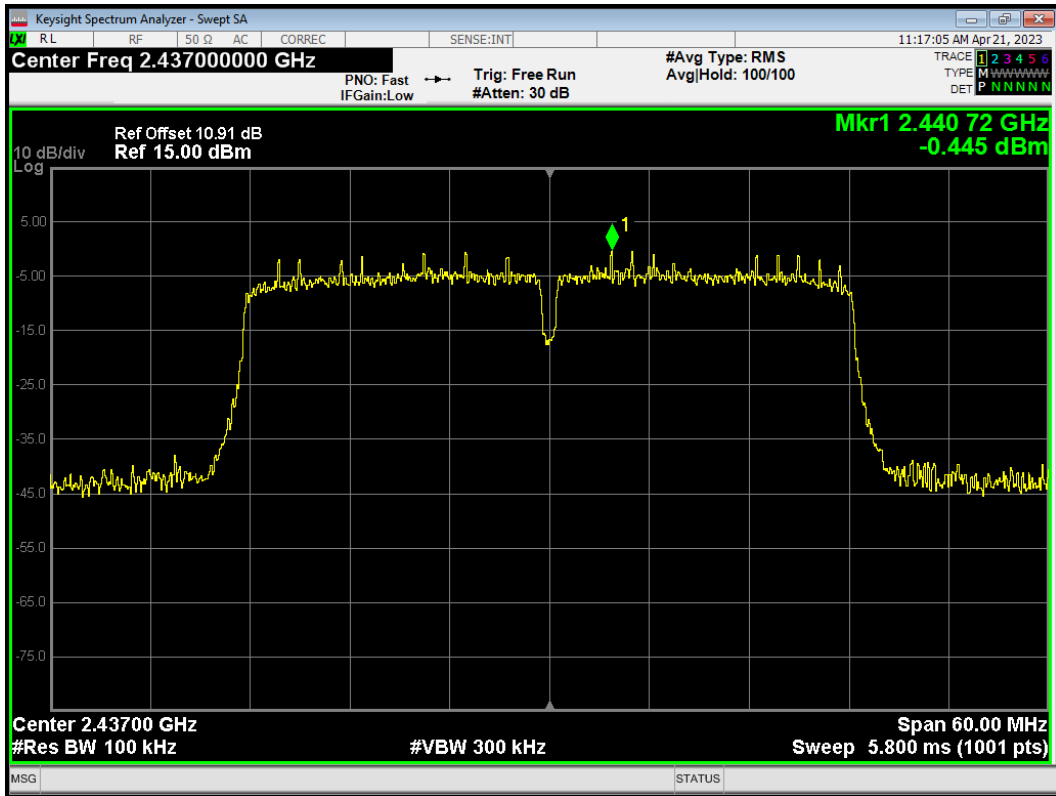

Tx. Spurious 802.11n (HT40) 2437MHz Emission

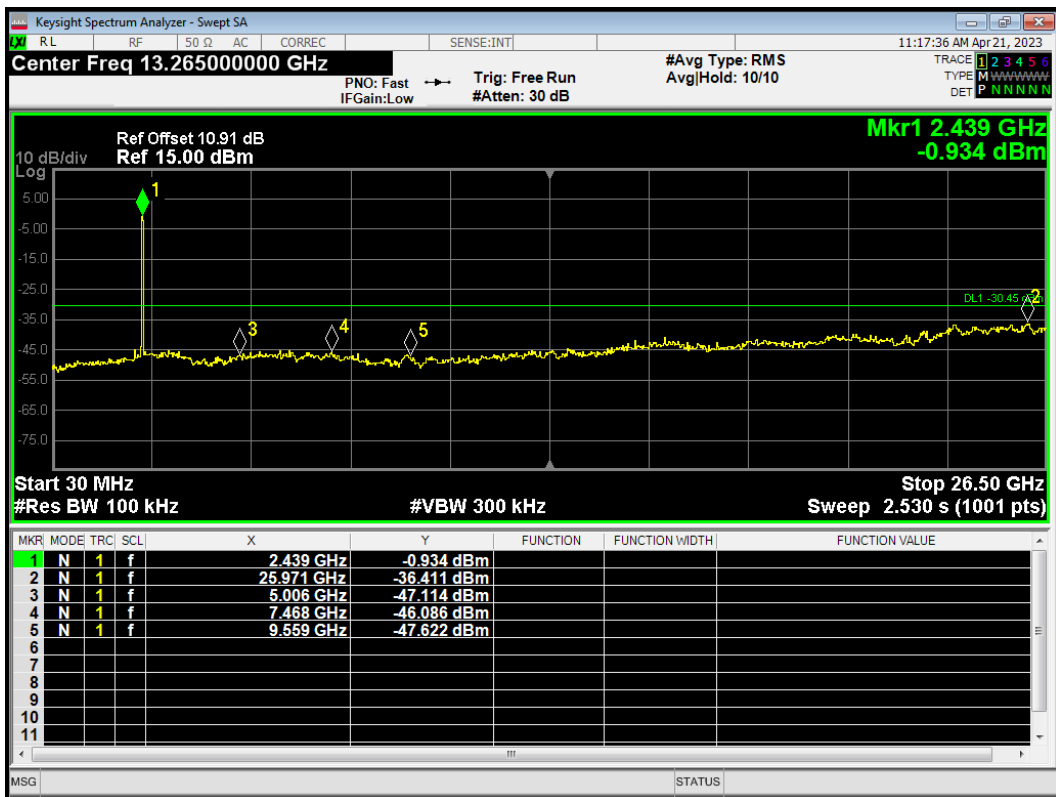

Tx. Spurious 802.11n (HT40) 2442MHz Ref

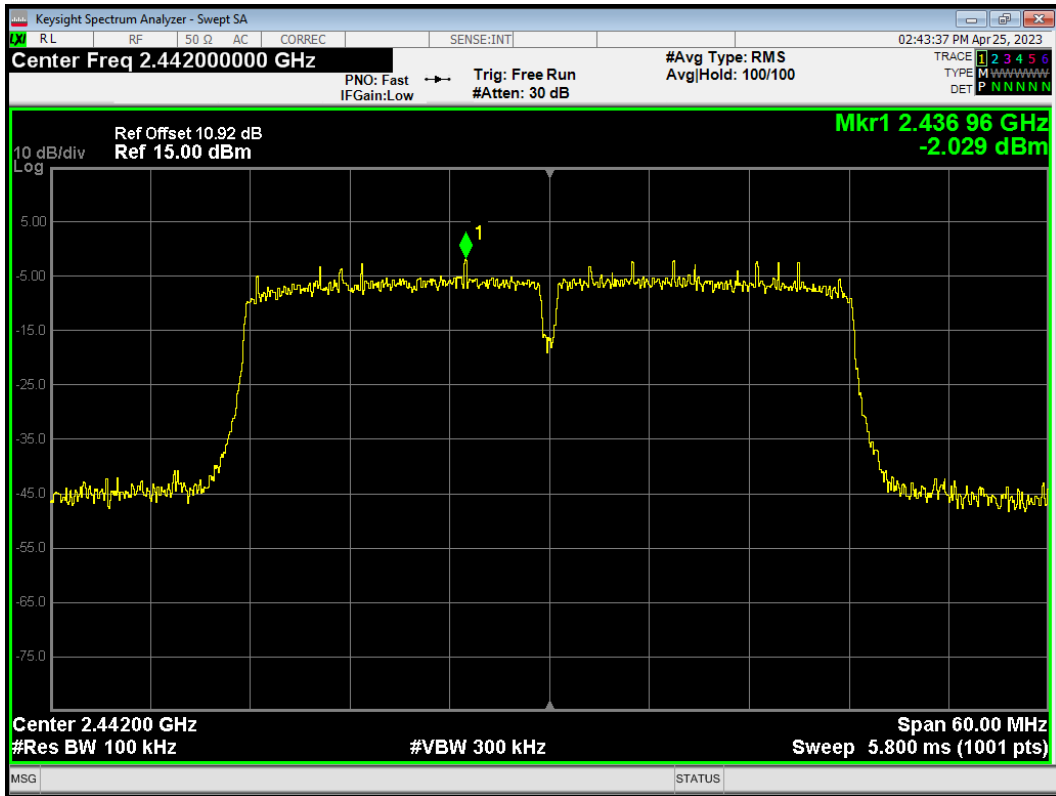

Tx. Spurious 802.11n (HT40) 2442MHz Emission

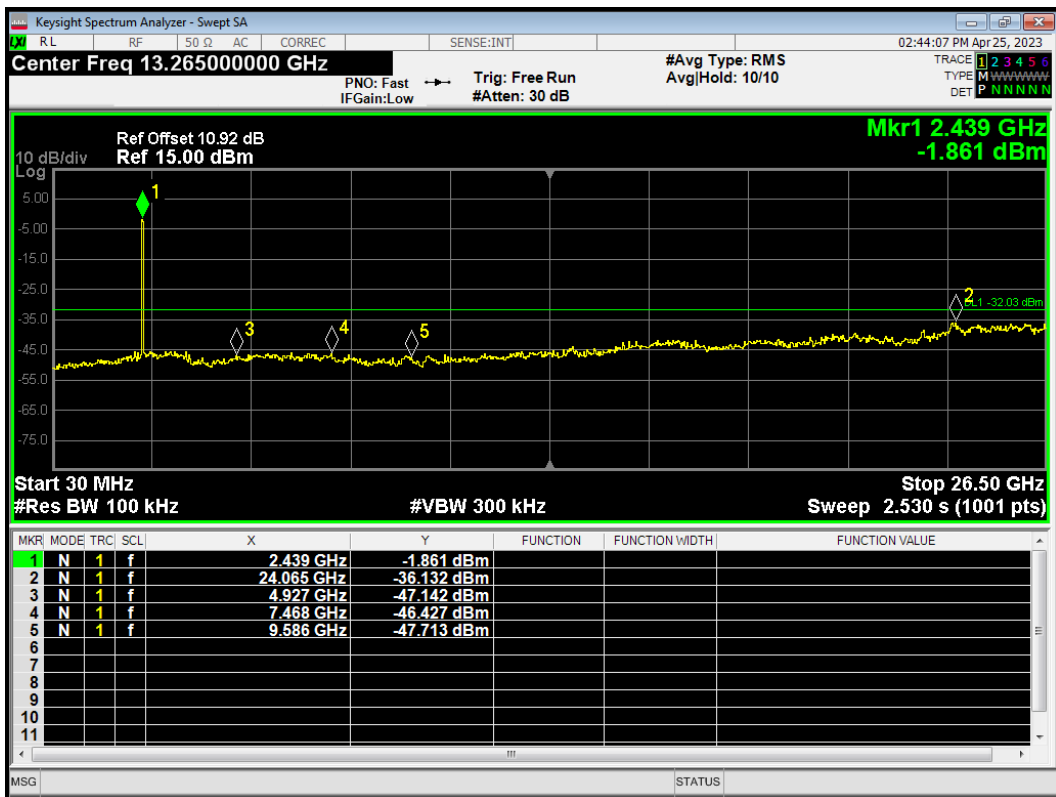

Tx. Spurious 802.11n (HT40) 2447MHz Ref

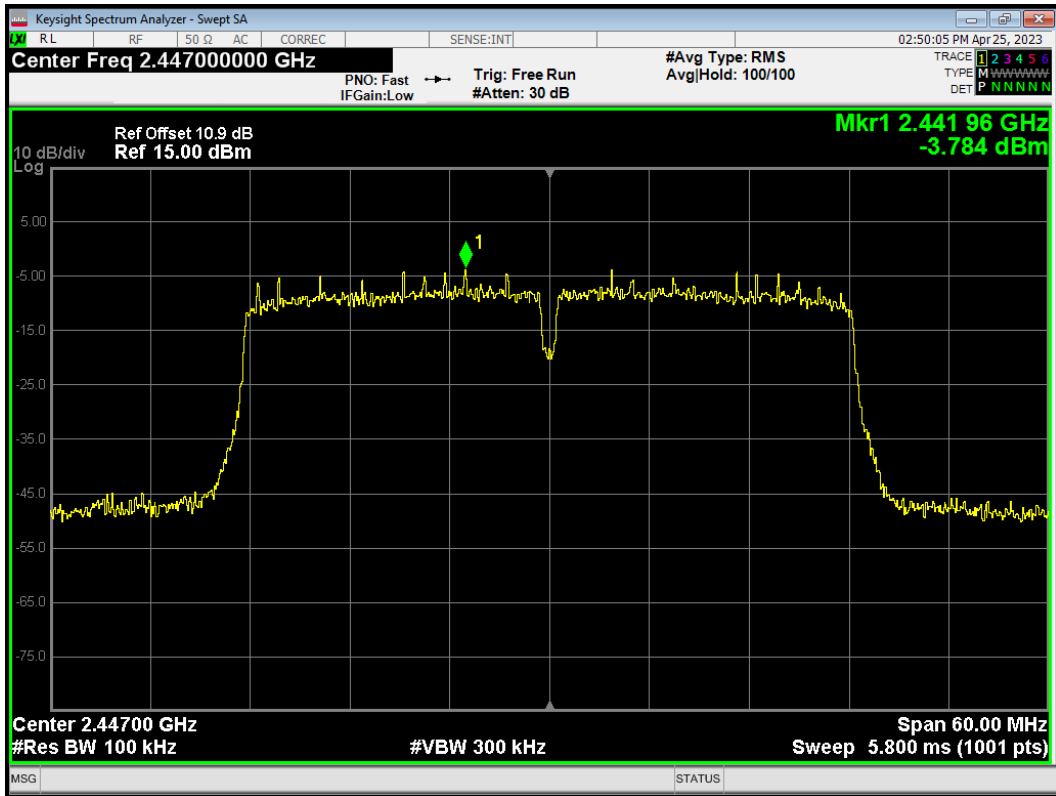

Tx. Spurious 802.11n (HT40) 2447MHz Emission

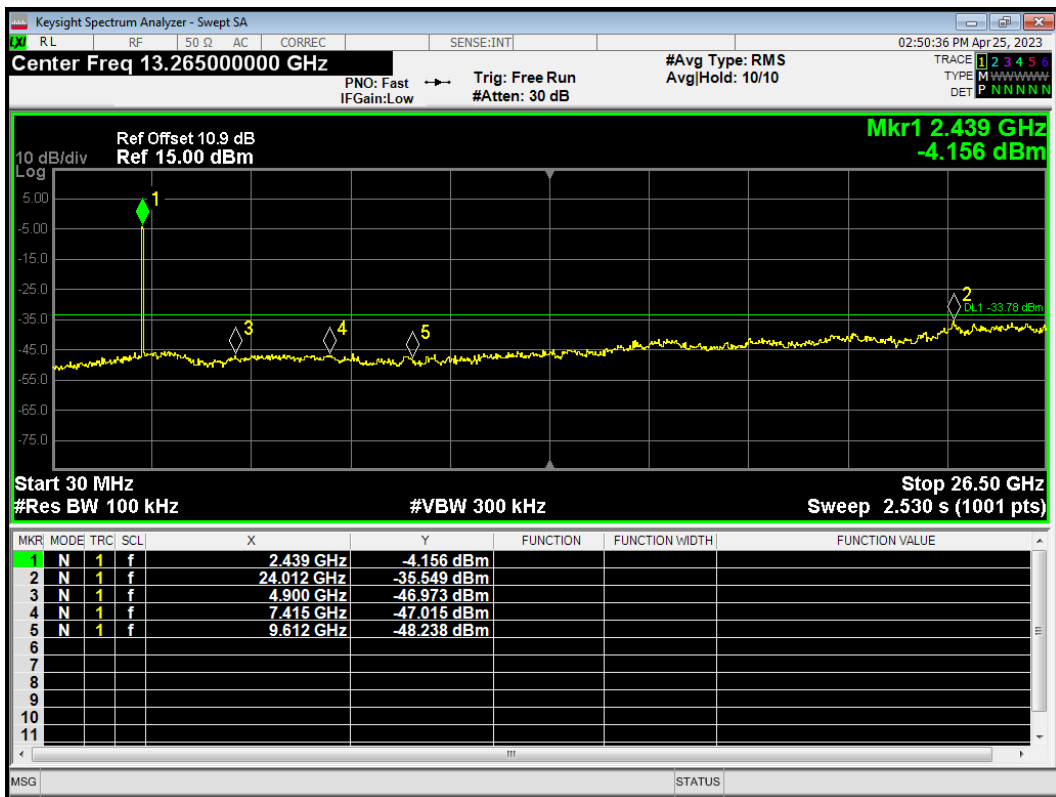

Tx. Spurious 802.11n (HT40) 2452MHz Ref

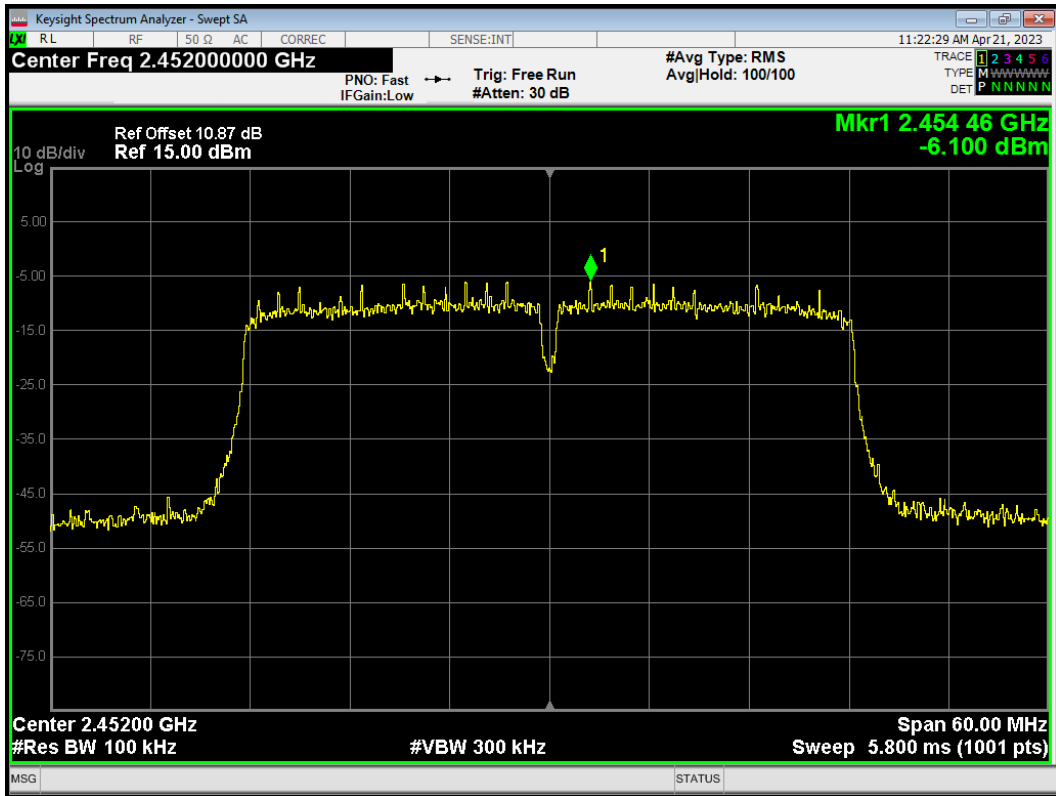

Tx. Spurious 802.11n (HT40) 2452MHz Emission

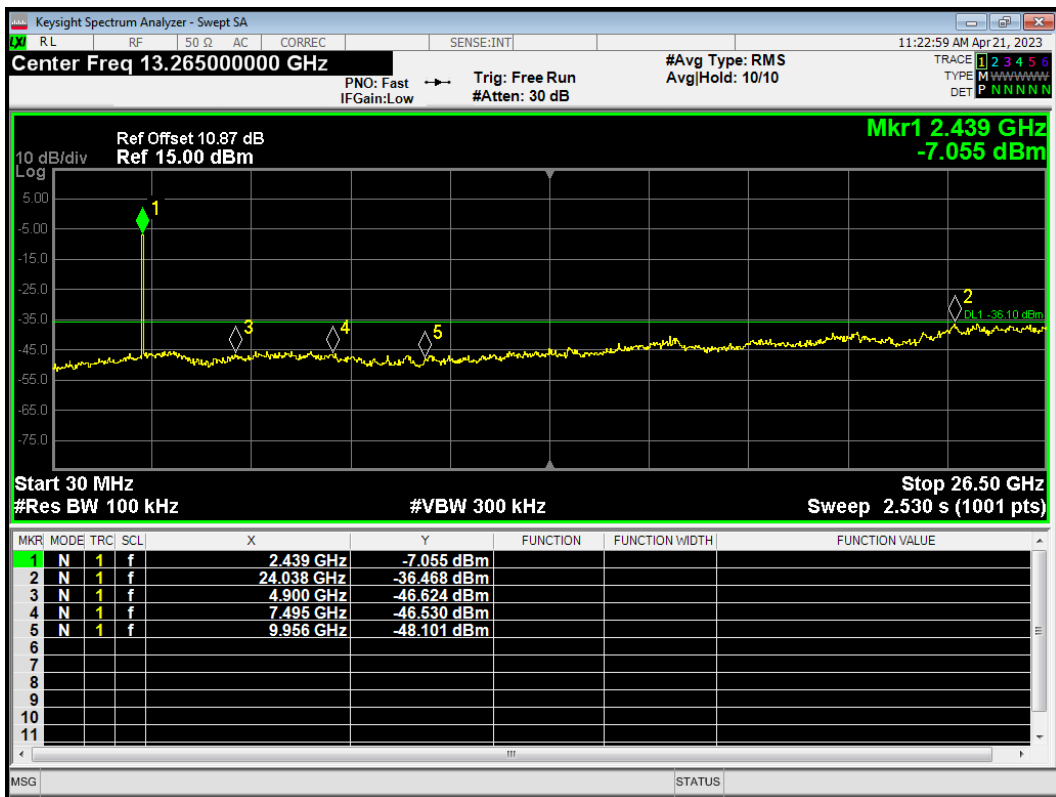



Bluetooth LE

Tx. Spurious BLE 2402MHz Ref

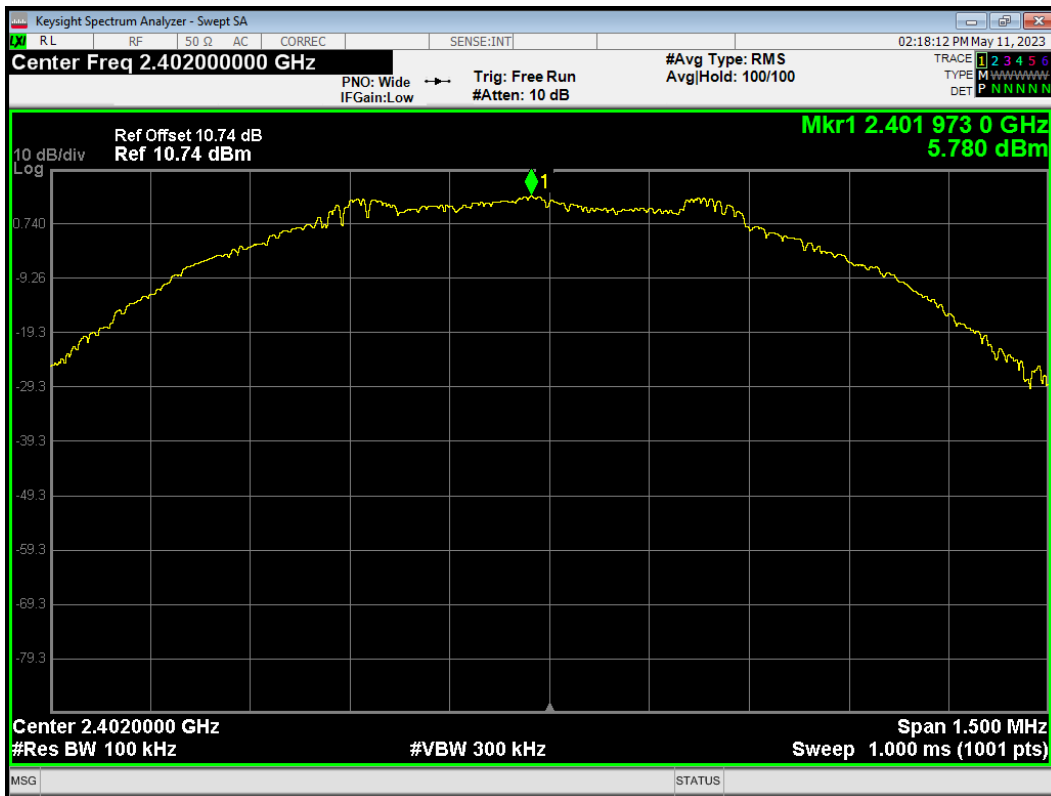

Tx. Spurious BLE 2402MHz Emission

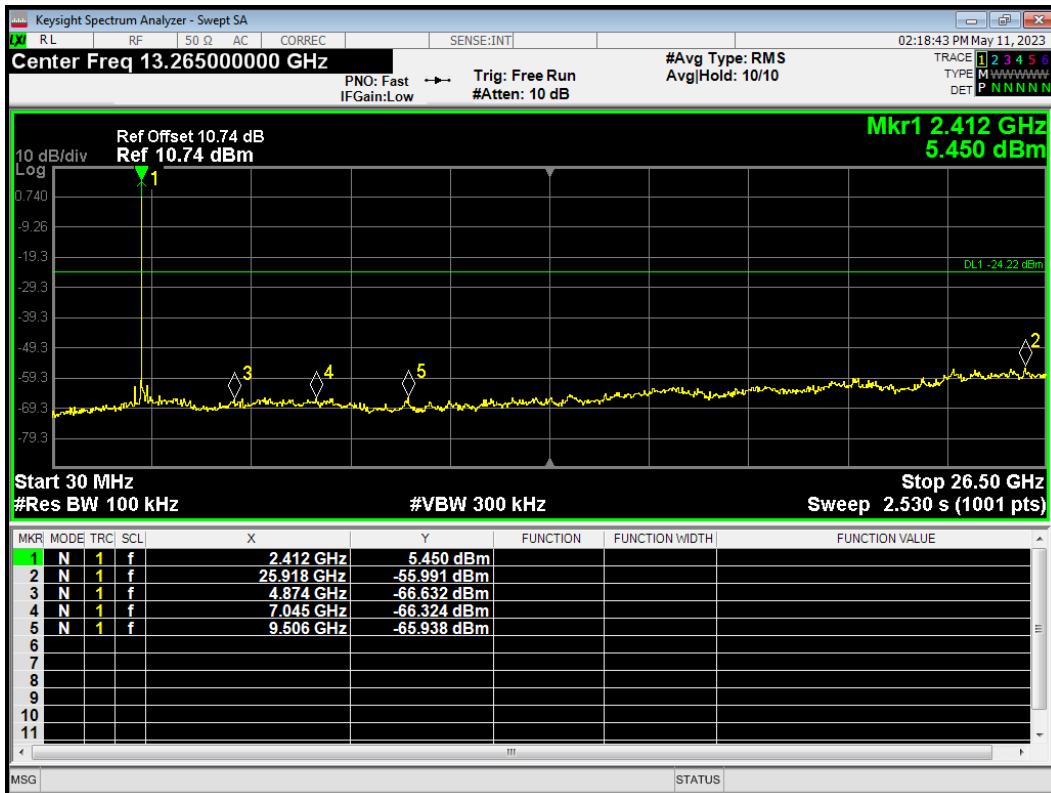

Tx. Spurious BLE 2440MHz Ref

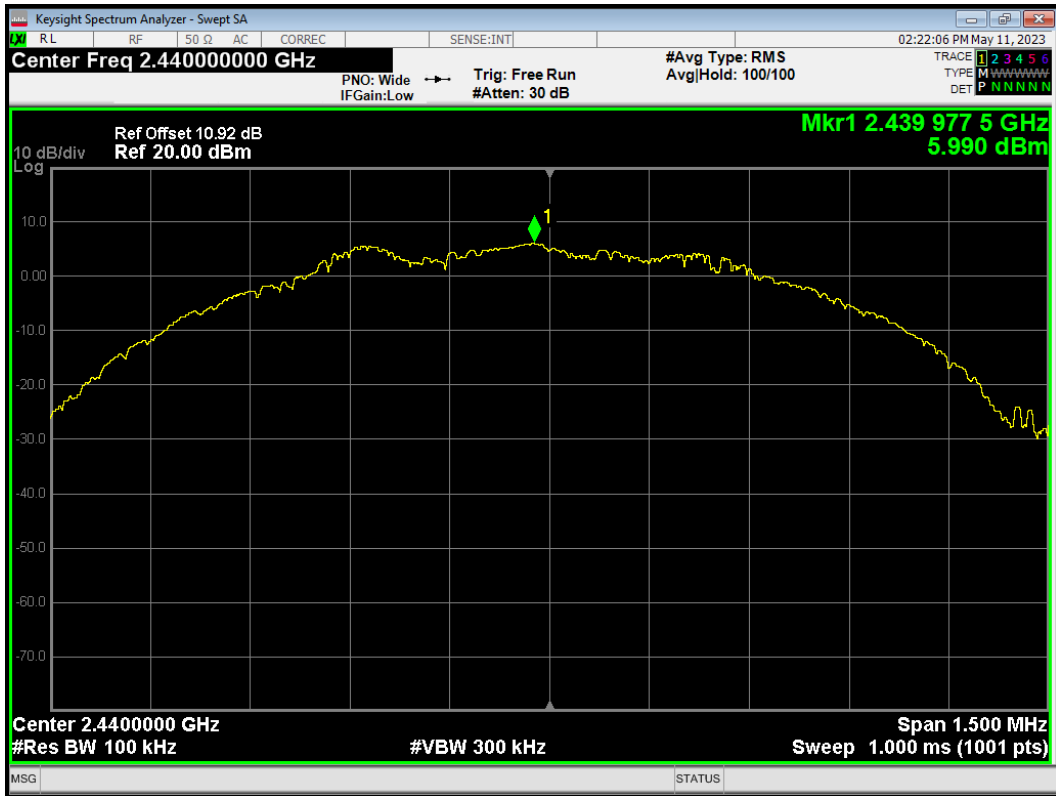

Tx. Spurious BLE 2440MHz Emission

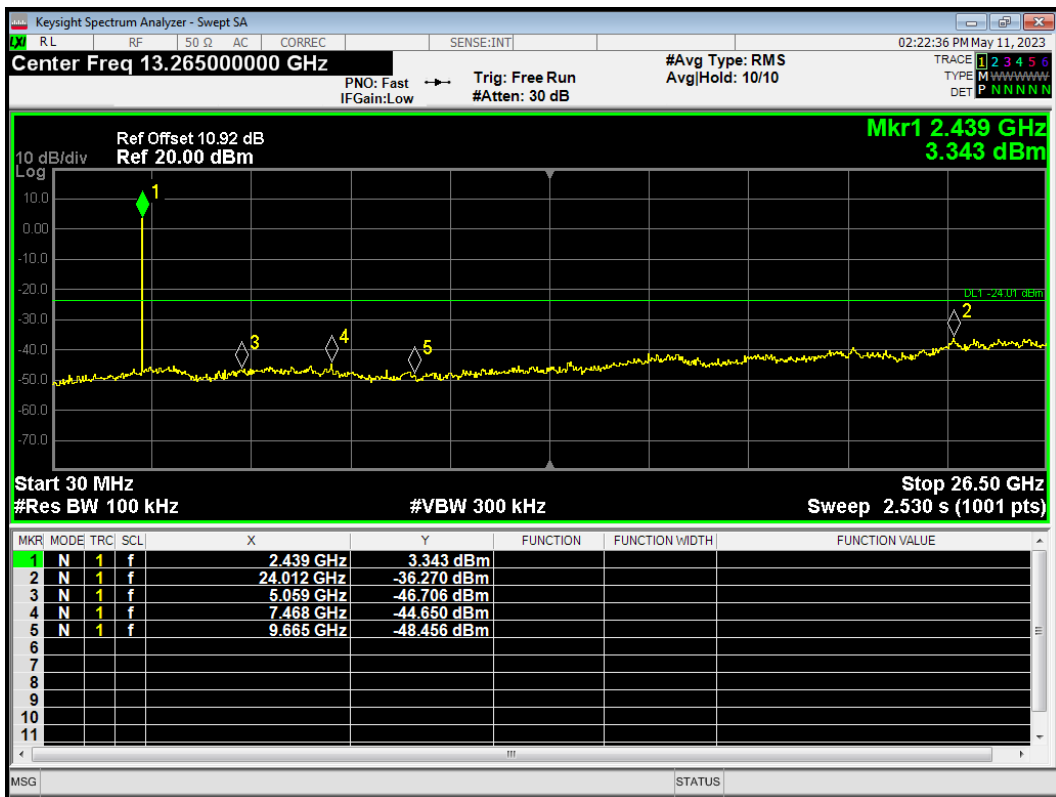

Tx. Spurious BLE 2480MHz Ref

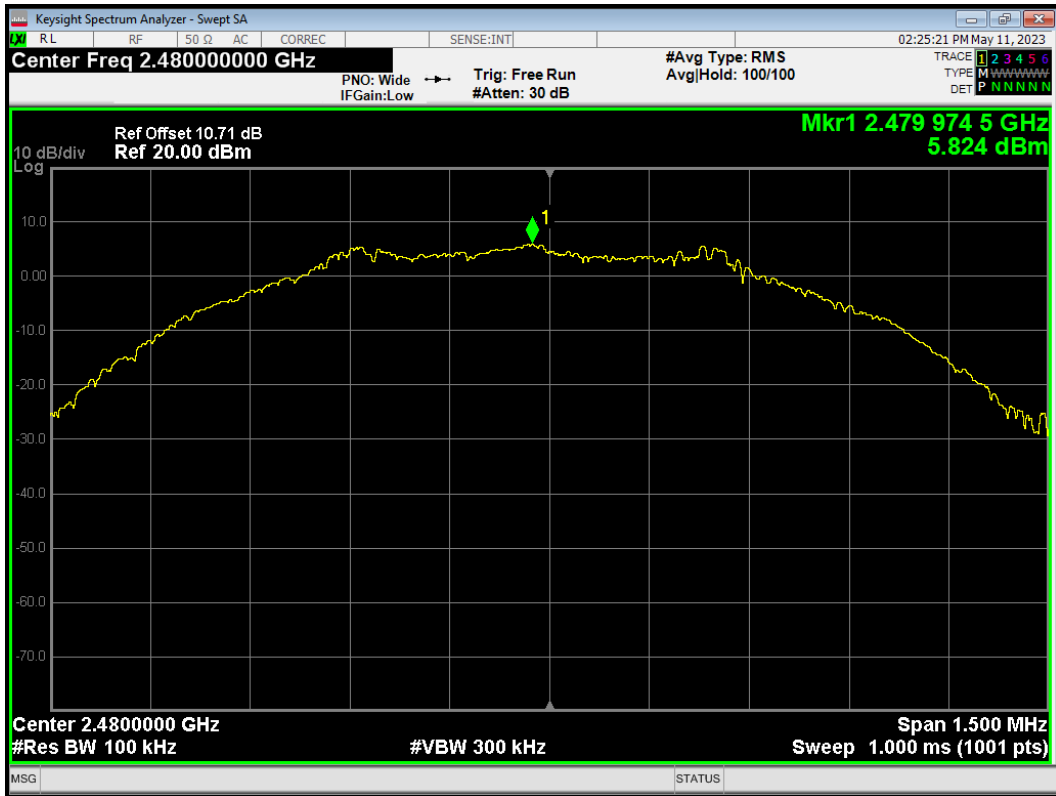

Tx. Spurious BLE 2480MHz Emission

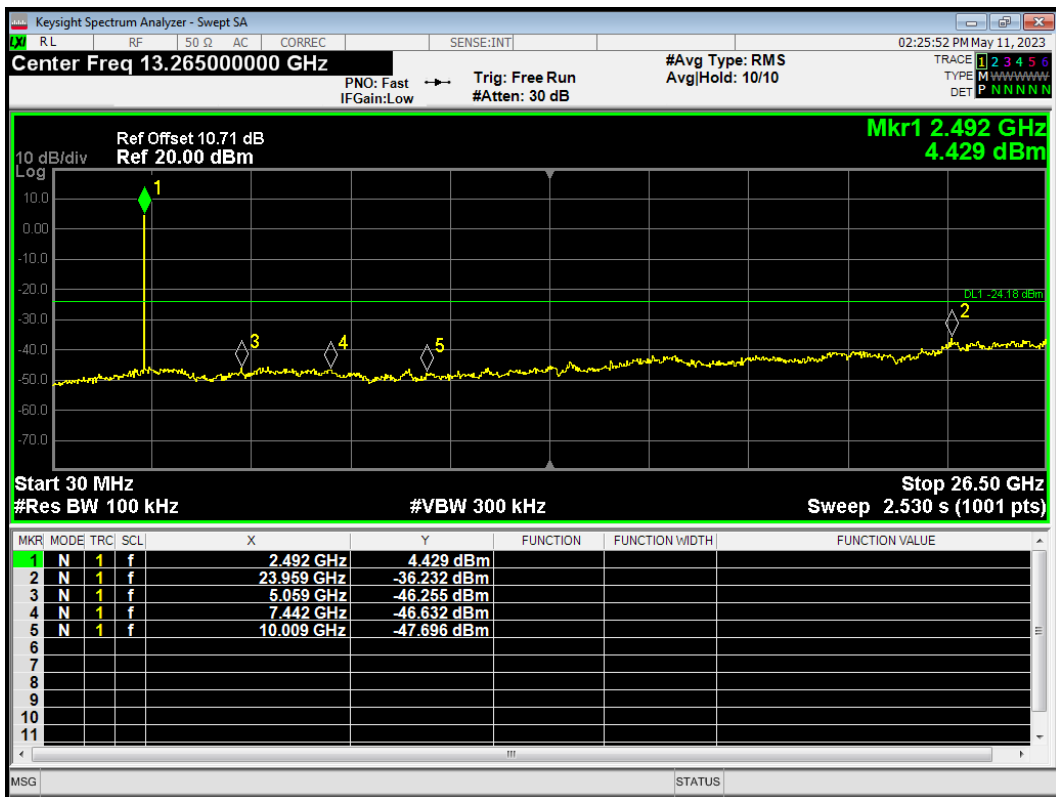

## 5.6. Unwanted Emission

### Ambient Condition

Temperature	Relative humidity
20°C ~25°C	45%~50%

### Method of Measurement

The test set-up was made in accordance to the general provisions of ANSI C63.10.

The Equipment Under Test (EUT) was set up on a non-conductive table in the semi-anechoic chamber. The test was performed at the distance of 3 m between the EUT and the receiving antenna.

The turntable shall be rotated from 0 to 360 degrees for detecting the maximum of radiated spurious signal level. The measurements shall be repeated with orthogonal polarization of the test antenna. The data of cable loss and antenna factor has been calibrated in full testing frequency range before the testing. Sweep the Restricted Band and the emissions less than 20 dB below the permissible value are reported.

The radiated emissions measurements were made in a typical installation configuration.

Sweep the whole frequency band through the range from 9 kHz to the 10th harmonic of the carrier, and the emissions less than 20 dB below the permissible value are reported.

This method refer to ANSI C63.10.

The procedure for peak unwanted emissions measurements above 1000 MHz is as follows:

Set the spectrum analyzer in the following:

9kHz~150 kHz

RBW=200Hz, VBW=1kHz/ Sweep=AUTO

150 kHz~30MHz

RBW=9KHz, VBW=30KHz,/ Sweep=AUTO

Below 1GHz

RBW=100kHz / VBW=300kHz / Sweep=AUTO

a) Peak emission levels are measured by setting the instrument as follows:

Above 1GHz

PEAK: RBW=1MHz VBW=3MHz/ Sweep=AUTO

b) Average emission levels are measured by setting the instrument as follows:

Above 1GHz

AVERAGE: RBW=1MHz / VBW=3MHz / Sweep=AUTO

c) Detector: The measurements employing a CISPR quasi-peak detector except for the frequency bands 9-90 kHz, 110-490 kHz and above 1000 MHz. Radiated emission limits in these three bands are based on measurements employing an average detector.

d) Averaging type = power (i.e., rms) (As an alternative, the detector and averaging type may be set for linear voltage averaging. Some instruments require linear display mode to use linear voltage

averaging. Log or dB averaging shall not be used.)

e) Sweep time = auto.

f) Perform a trace average of at least 100 traces if the transmission is continuous. If the transmission is not continuous, then the number of traces shall be increased by a factor of  $1 / D$ , where  $D$  is the duty cycle. For example, with 50% duty cycle, at least 200 traces shall be averaged. (If a specific emission is demonstrated to be continuous—i.e., 100% duty cycle—then rather than turning ON and OFF with the transmit cycle, at least 100 traces shall be averaged.)

g) If tests are performed with the EUT transmitting at a duty cycle less than 98%, then a correction factor shall be added to the measurement results prior to comparing with the emission limit, to compute the emission level that would have been measured had the test been performed at 100% duty cycle. The correction factor is computed as follows:

1) If power averaging (rms) mode was used in the preceding step e), then the correction factor is  $[10 \log (1 / D)]$ , where  $D$  is the duty cycle. For example, if the transmit duty cycle was 50%, then 3 dB shall be added to the measured emission levels.

2) If linear voltage averaging mode was used in the preceding step e), then the correction factor is  $[20 \log (1 / D)]$ , where  $D$  is the duty cycle. For example, if the transmit duty cycle was 50%, then 6 dB shall be added to the measured emission levels.

3) If a specific emission is demonstrated to be continuous (100% duty cycle) rather than turning ON and OFF with the transmit cycle, then no duty cycle correction is required for that emission.

The test is in transmitting mode.

**Test Setup**

**9KHz~ 30MHz**

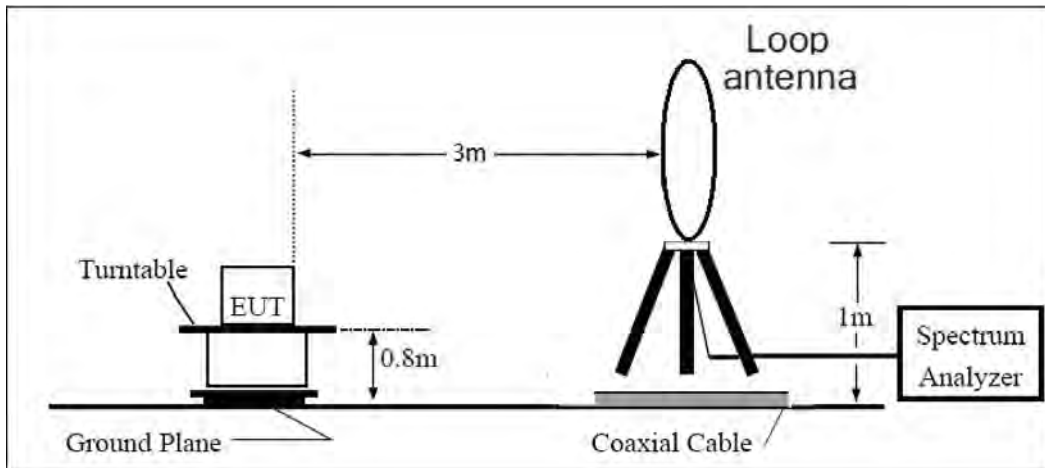

**30MHz~ 1GHz**

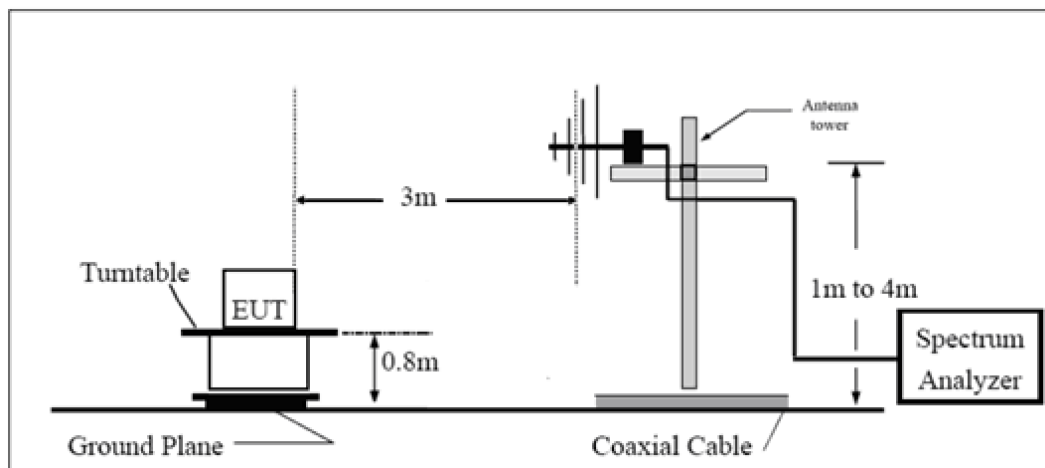

**Above 1GHz**

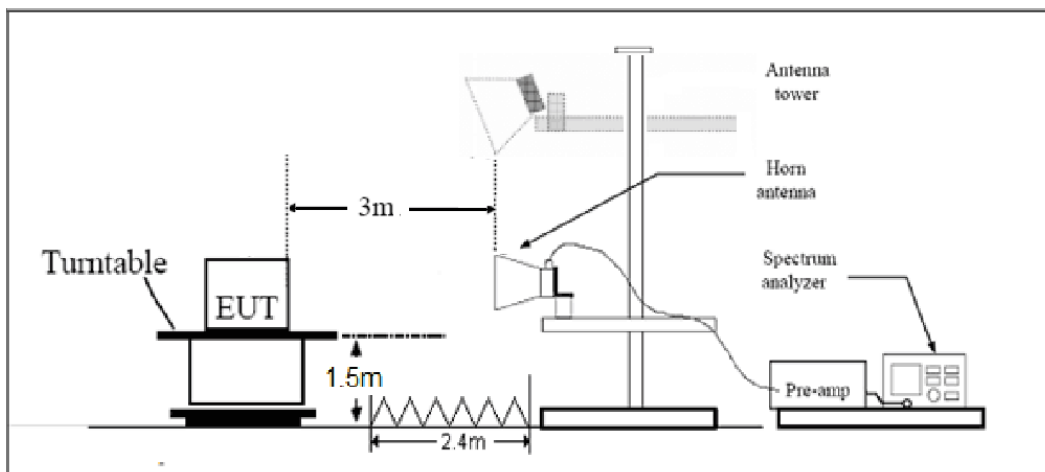

Note: Area side:2.4mX3.6m

### Limits

Rule Part 15.247(d) specifies that “In addition, radiated emissions which fall in the restricted bands, as defined in § 15.205(a), must also comply with the radiated emission limits specified in § 15.209(a) (see § 15.205(c)).”

Limit in restricted band

Frequency of emission (MHz)	Field strength( $\mu\text{V}/\text{m}$ )	Field strength( $\text{dB}\mu\text{V}/\text{m}$ )
0.009–0.490	2400/F(kHz)	/
0.490–1.705	24000/F(kHz)	/
1.705–30.0	30	/
30-88	100	40
88-216	150	43.5
216-960	200	46
Above960	500	54

### §15.35(b)

There is also a limit on the radio frequency emissions, as measured using instrumentation with a peak detector function, corresponding to 20 dB above the maximum permitted average limit.

Peak Limit=74  $\text{dB}\mu\text{V}/\text{m}$

Average Limit=54  $\text{dB}\mu\text{V}/\text{m}$

Spurious Radiated Emissions are permitted in any of the frequency bands listed below:

MHz	MHz	MHz	GHz
0.090-0.110	16.42-16.423	399.9-410	4.5-5.15
<sup>1</sup> 0.495-0.505	16.69475-16.69525	608-614	5.35-5.46
2.1735-2.1905	16.80425-16.80475	960-1240	7.25-7.75
4.125-4.128	25.5-25.67	1300-1427	8.025-8.5
4.17725-4.17775	37.5-38.25	1435-1626.5	9.0-9.2
4.20725-4.20775	73-74.6	1645.5-1646.5	9.3-9.5
6.215-6.218	74.8-75.2	1660-1710	10.6-12.7
6.26775-6.26825	108-121.94	1718.8-1722.2	13.25-13.4
6.31175-6.31225	123-138	2200-2300	14.47-14.5
8.291-8.294	149.9-150.05	2310-2390	15.35-16.2
8.362-8.366	156.52475-156.52525	2483.5-2500	17.7-21.4
8.37625-8.38675	156.7-156.9	2690-2900	22.01-23.12
8.41425-8.41475	162.0125-167.17	3260-3267	23.6-24.0
12.29-12.293	167.72-173.2	3332-3339	31.2-31.8
12.51975-12.52025	240-285	3345.8-3358	36.43-36.5
12.57675-12.57725	322-335.4	3600-4400	( <sup>2</sup> )
13.36-13.41			

### Measurement Uncertainty

The assessed measurement uncertainty to ensure 95% confidence level for the normal distribution is with the coverage factor  $k = 1.96$ .

Frequency	Uncertainty
9KHz-30MHz	3.55 dB
30MHz-200MHz	4.17 dB
200MHz-1GHz	4.84 dB
1-18GHz	4.35 dB
18-26.5GHz	5.90 dB



**Test Results:**

A symbol (dB $\mu$ V/m) in the test plot below means (dB $\mu$ V/m)



802.11b-Channel 1 Peak+ Average

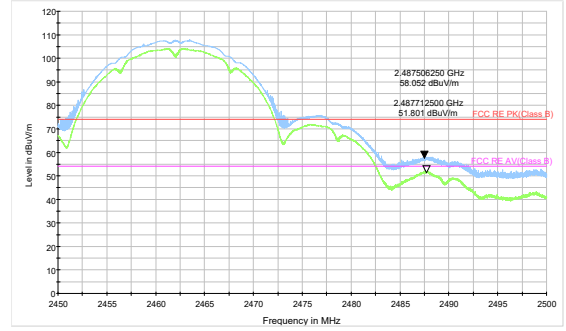

802.11b-Channel 11 Peak+ Average

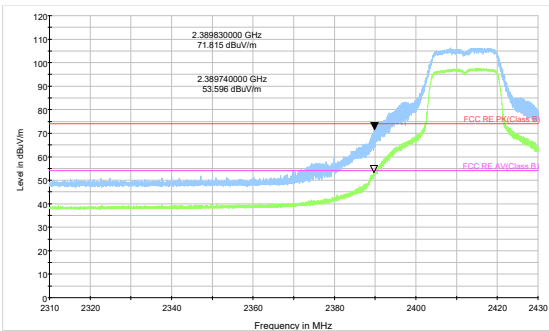

802.11g-Channel 1 Peak+ Average

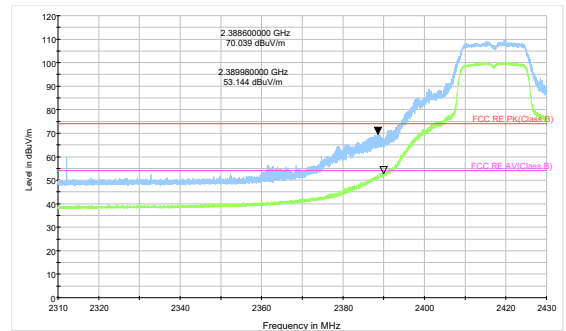

802.11g-Channel 2 Peak+ Average

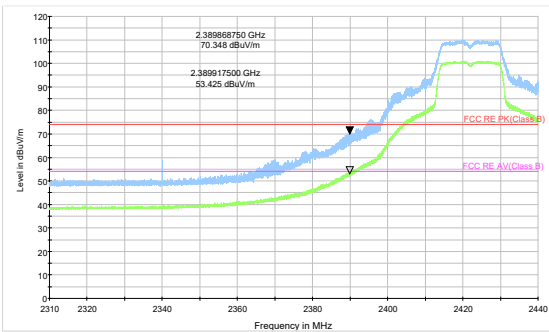

802.11g-Channel 3 Peak+ Average

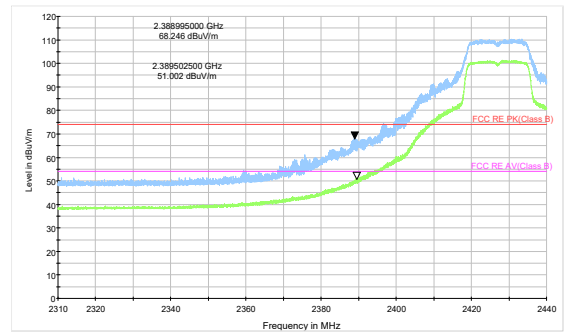

802.11g-Channel 4 Peak+ Average

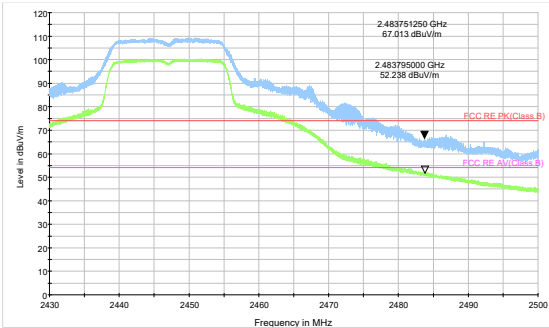

802.11g-Channel 8 Peak+ Average

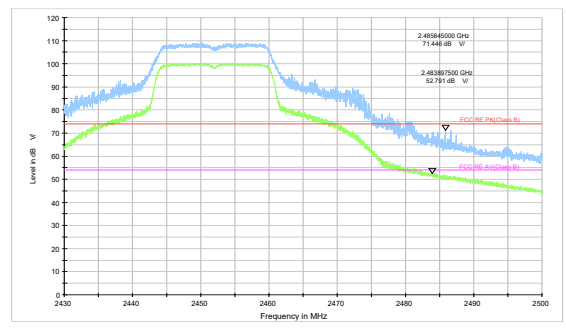

802.11g-Channel 9 Peak+ Average

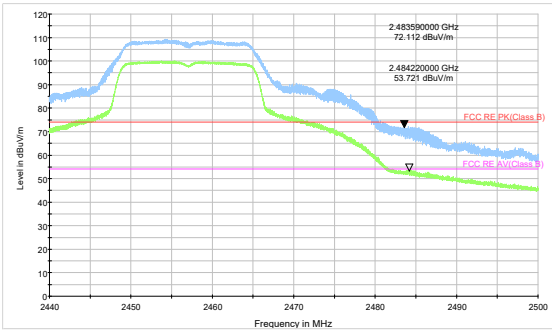

802.11g-Channel 10 Peak+ Average

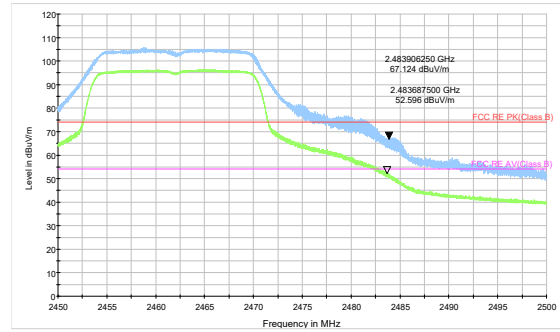

802.11g-Channel 11 Peak+ Average

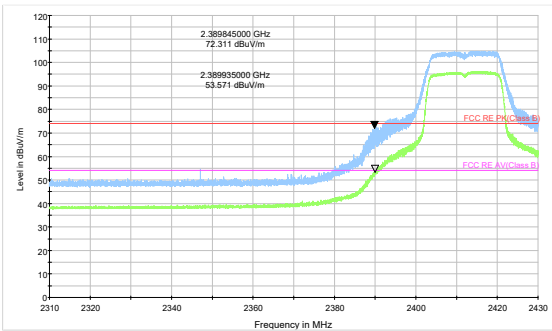

802.11n HT20 -Channel 1 Peak+ Average

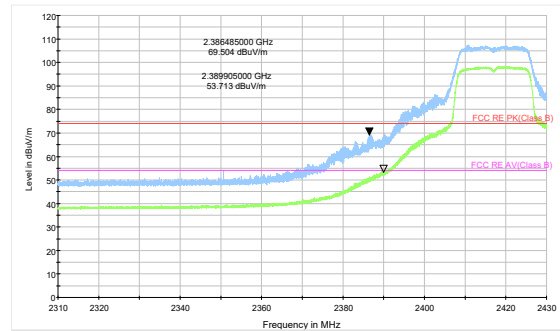

802.11n HT20 -Channel 2 Peak+ Average

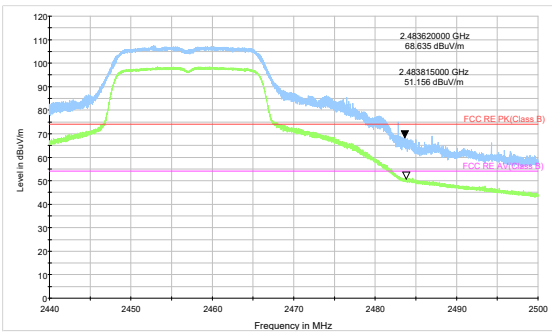

802.11n HT20 -Channel 10 Peak+ Average

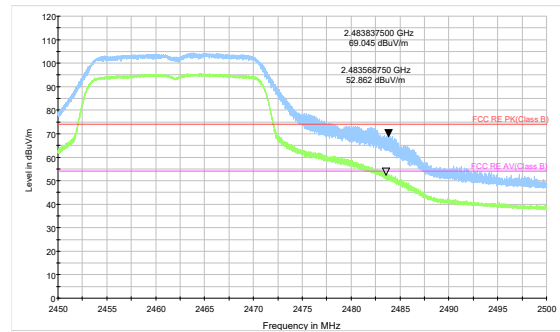

802.11n HT20 -Channel 11 Peak+ Average

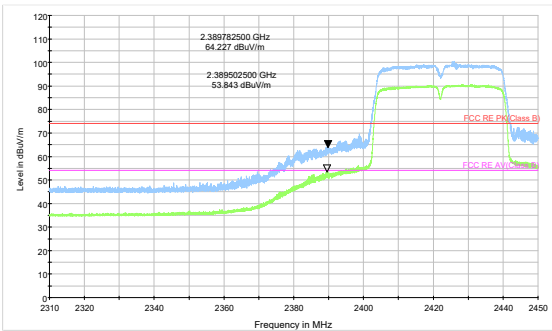

802.11n HT40 -Channel 3 Peak+ Average

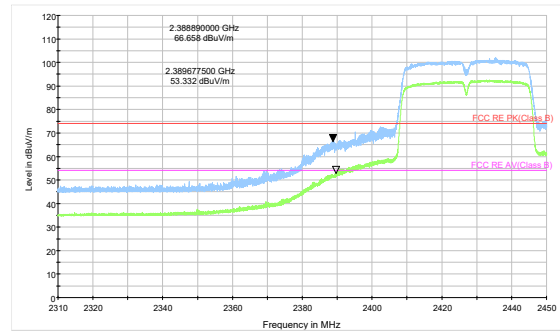

802.11n HT40 -Channel 4 Peak+ Average

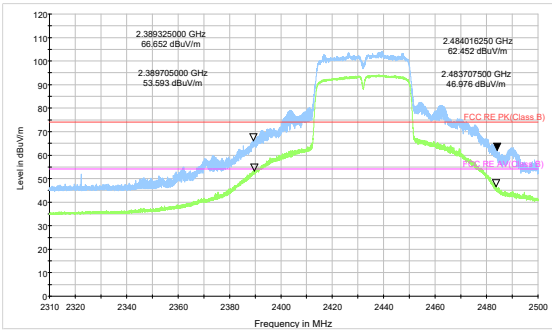

802.11n HT40 -Channel 5 Peak+ Average

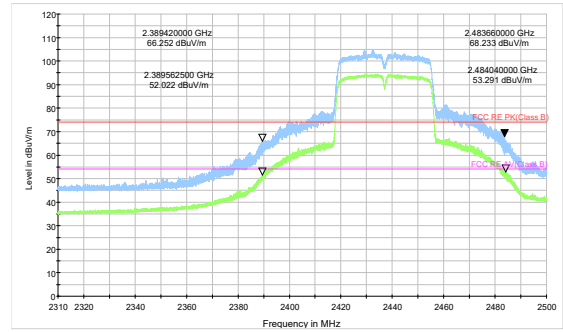

802.11n HT40 -Channel 6 Peak+ Average

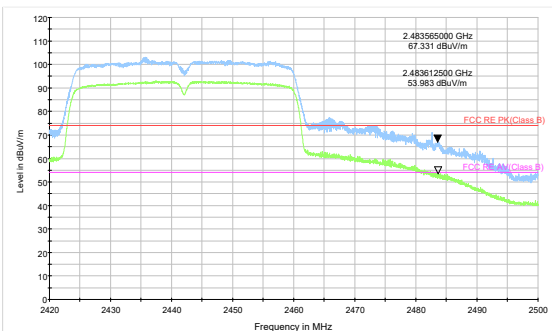

802.11n HT40 -Channel 7 Peak+ Average

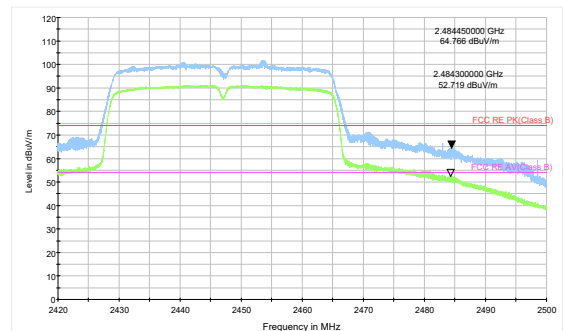

802.11n HT40 -Channel 8 Peak+ Average

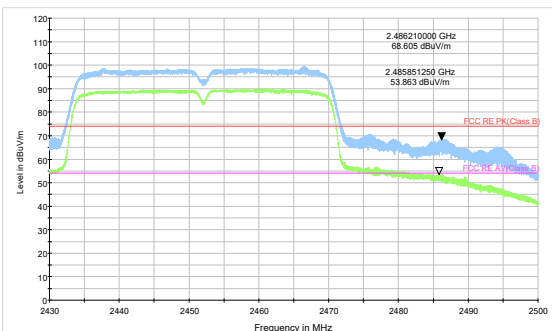

802.11n HT40 -Channel 9 Peak+ Average

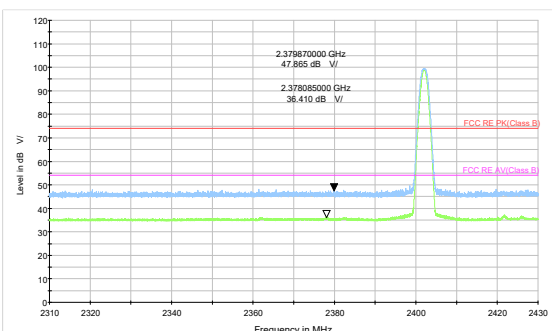

Bluetooth LE Channel 0 Peak+ Average

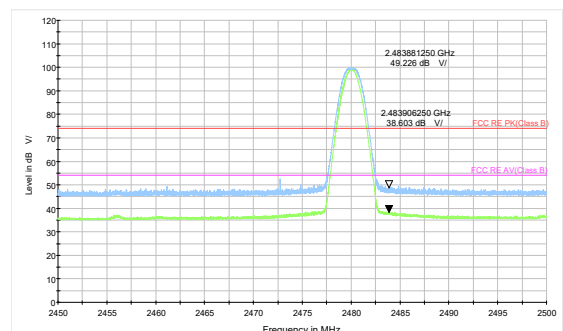

Bluetooth LE Channel 39 Peak+ Average

**Result of RE**

**Test result**

Sweep the whole frequency band through the range from 9kHz to the 10th harmonic of the carrier, the Emissions in the frequency band 9kHz-30MHz are more than 20dB below the limit are not reported.

The following graphs display the maximum values of horizontal and vertical by software. For above 1GHz, Blue trace uses the peak detection, Green trace uses the average detection.

**Continuous TX mode:**

**Wi-Fi 2.4G**

During the test, the Radiates Emission from 30MHz to 1GHz was performed in all modes with all channels, 802.11g, Channel 9 are selected as the worst condition. The test data of the worst-case condition was recorded in this report.

A symbol (  $\text{dB } \nabla$  ) in the test plot below means (dB $\mu$ V/m)

A symbol (  $\text{dBuV/m}$  ) in the test plot below means (dB $\mu$ V/m)

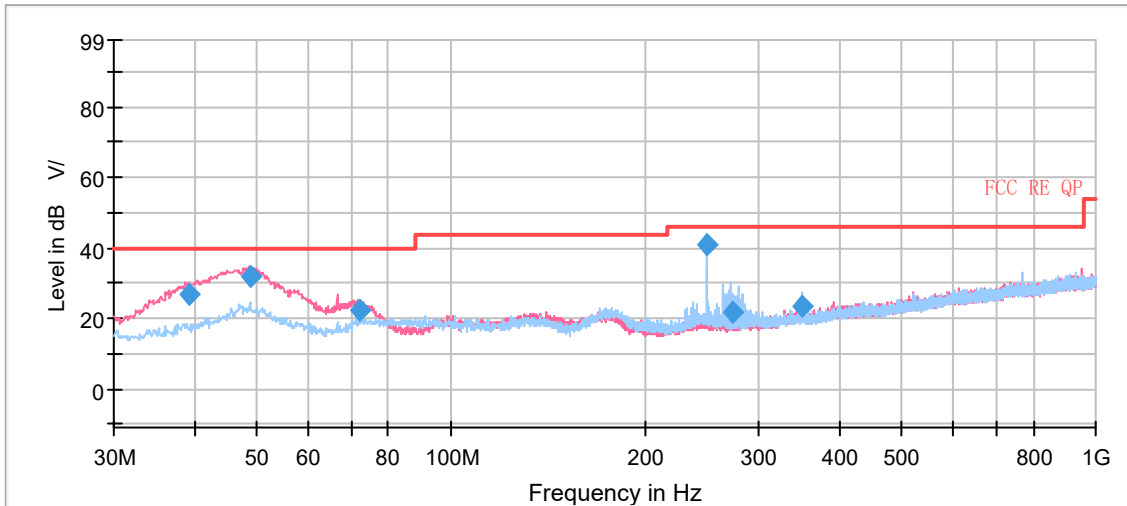

Radiates Emission from 30MHz to 1GHz

Frequency (MHz)	Quasi-Peak (dB $\mu$ V/m)	Limit (dB $\mu$ V/m)	Margin (dB)	Height (cm)	Polarization	Azimuth (deg)	Correct Factor (dB)
39.138925	26.66	40.00	13.34	100.0	V	0.0	19.2
48.829138	31.83	40.00	8.17	100.0	V	219.0	20.6
72.031450	22.07	40.00	17.93	184.0	V	201.0	15.5
249.978000	41.09	46.00	4.91	100.0	H	145.0	19.9
272.976000	21.47	46.00	24.53	125.0	H	65.0	19.7
349.988750	23.68	46.00	22.32	100.0	H	286.0	22.1

**Remark: 1. Correction Factor = Antenna factor + Insertion loss (cable loss + amplifier gain)**

**2. Margin = Limit – Quasi-Peak**

802.11b CH1

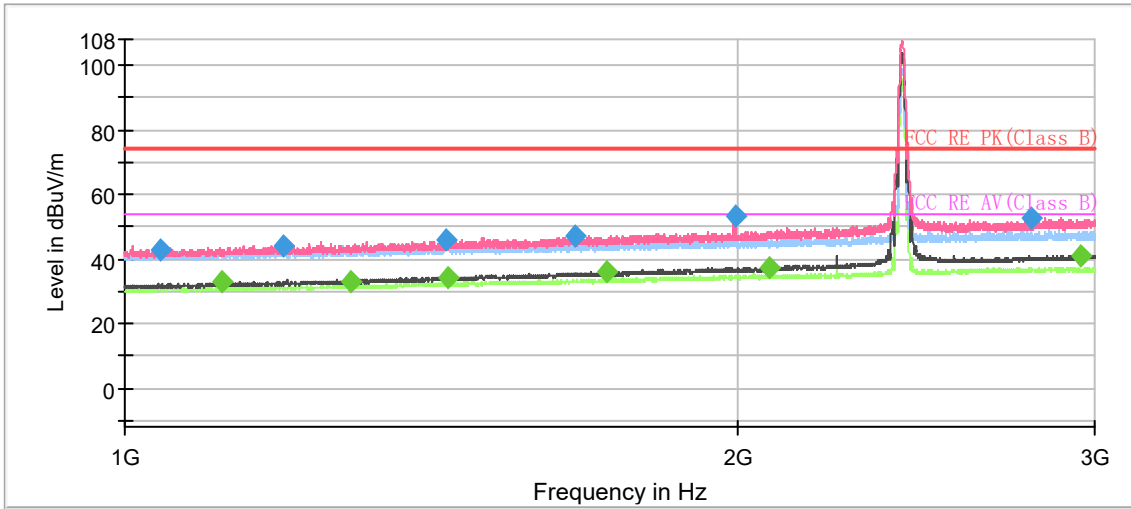

Note: The signal beyond the limit is carrier.  
Radiates Emission from 1GHz to 3GHz

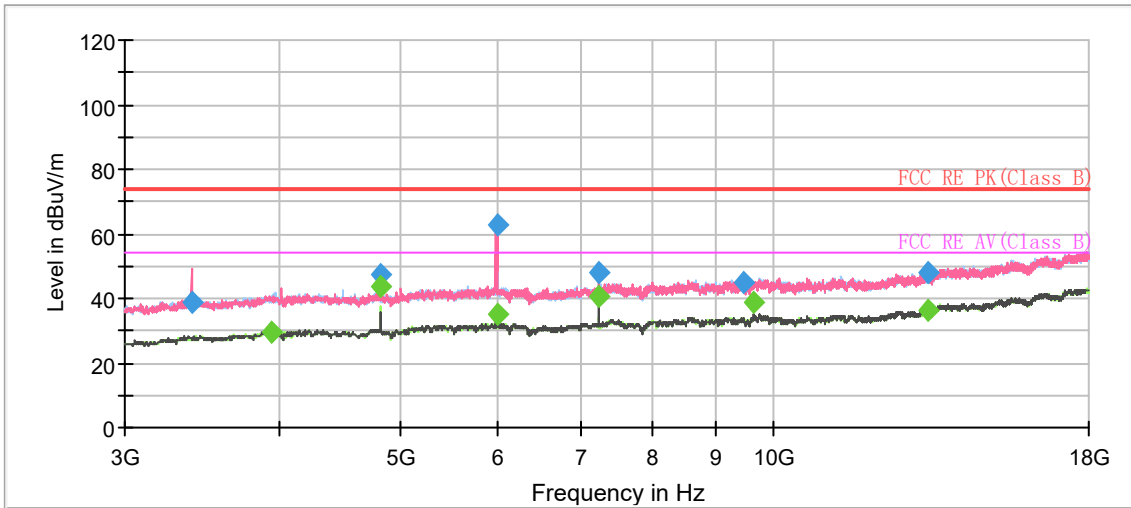

Radiates Emission from 3GHz to 18GHz

Frequency (MHz)	MaxPeak (dB $\mu$ V/m)	Average (dB $\mu$ V/m)	Limit (dB $\mu$ V/m)	Margin (dB)	Meas. Time (ms)	Height (cm)	Pol	Azimuth (deg)	Corr. (dB/m)
1041.500000	42.60	---	74.00	31.40	500.0	200.0	V	208.0	-8.8
1117.500000	---	32.75	54.00	21.25	500.0	200.0	V	113.0	-8.3
1196.500000	44.11	---	74.00	29.89	500.0	200.0	V	149.0	-7.7
1291.000000	---	33.09	54.00	20.91	500.0	200.0	V	260.0	-7.2
1438.000000	45.94	---	74.00	28.06	500.0	200.0	H	353.0	-6.2
1442.000000	---	34.44	54.00	19.56	500.0	200.0	V	21.0	-6.2
1664.250000	47.07	---	74.00	26.93	500.0	200.0	V	58.0	-5.1
1725.250000	---	35.84	54.00	18.16	500.0	200.0	V	176.0	-4.8
1999.000000	53.29	---	74.00	20.71	500.0	200.0	V	212.0	-3.4
2076.500000	---	37.37	54.00	16.63	500.0	200.0	V	208.0	-3.1
2789.250000	52.61	---	74.00	21.39	500.0	200.0	V	26.0	0.0
2954.500000	---	41.22	54.00	12.78	500.0	200.0	V	265.0	0.4
4824.018750	---	43.67	54.00	10.33	500.0	100.0	H	329.0	-4.2

**Remark: 1. Correction Factor = Antenna factor + Insertion loss (cable loss + amplifier gain)**

**2. Margin = Limit - MAX Peak/ Average**

802.11b CH6

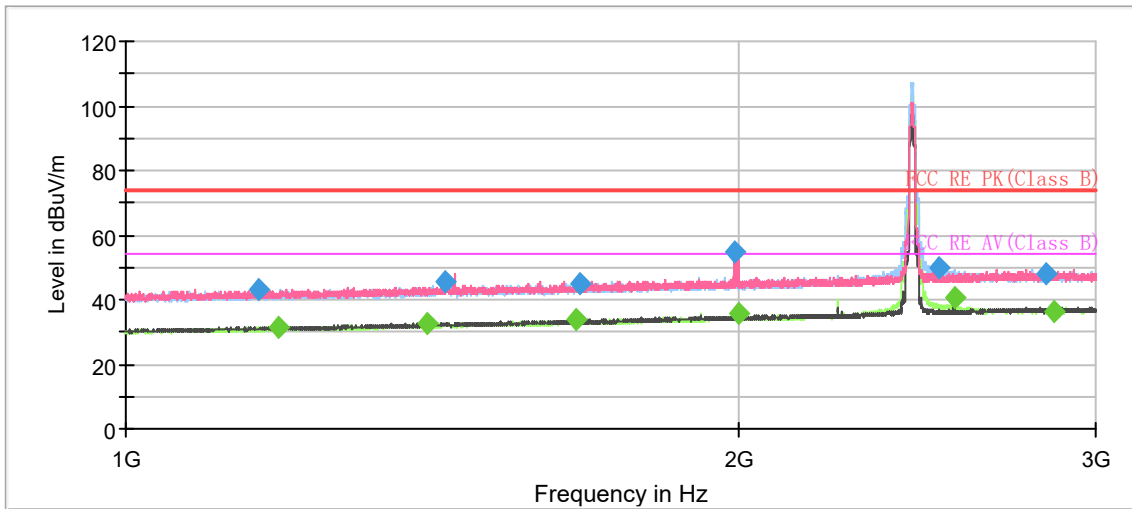

Note: The signal beyond the limit is carrier.  
Radiates Emission from 1GHz to 3GHz

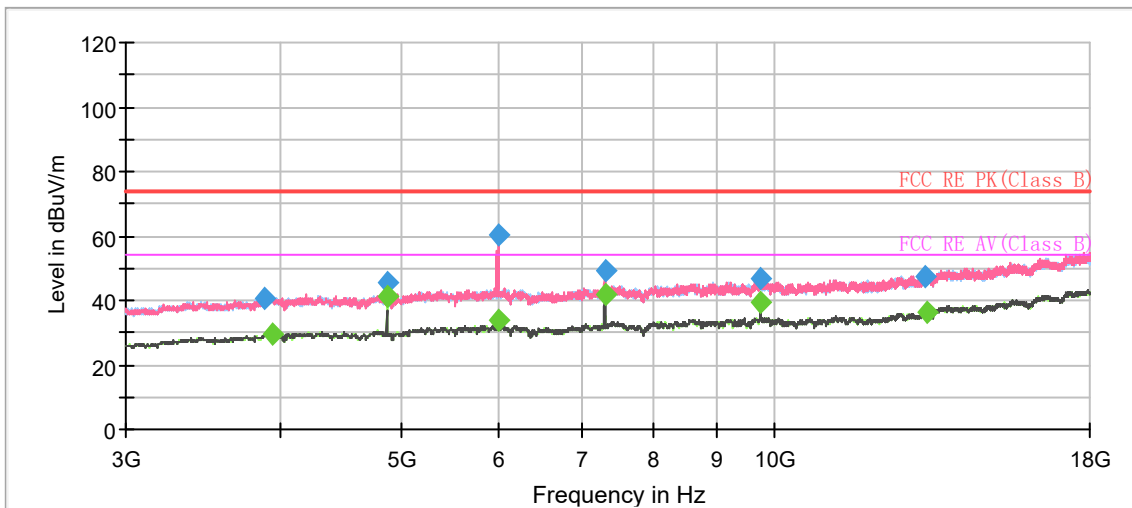

Radiates Emission from 3GHz to 18GHz

Frequency (MHz)	MaxPeak (dB $\mu$ V/m)	Average (dB $\mu$ V/m)	Limit (dB $\mu$ V/m)	Margin (dB)	Meas. Time (ms)	Height (cm)	Pol	Azimuth (deg)	Corr. (dB/m)
1162.250000	43.28	---	74.00	30.72	500.0	200.0	V	174.0	-8.0
1187.750000	---	31.62	54.00	22.38	500.0	200.0	H	283.0	-7.8
1406.250000	---	32.83	54.00	21.17	500.0	200.0	H	250.0	-6.4
1437.250000	45.69	---	74.00	28.31	500.0	200.0	H	255.0	-6.2
1665.000000	---	33.89	54.00	20.11	500.0	200.0	V	137.0	-5.1
1672.000000	44.79	---	74.00	29.21	500.0	200.0	H	278.0	-5.1
1994.750000	54.92	---	74.00	19.08	500.0	200.0	V	262.0	-3.5
2000.500000	---	35.88	54.00	18.12	500.0	200.0	V	197.0	-3.4
2513.000000	49.80	---	74.00	24.20	500.0	100.0	H	64.0	-1.1
2560.000000	---	40.33	54.00	13.67	500.0	100.0	H	341.0	-0.9
2835.500000	48.22	---	74.00	25.78	500.0	100.0	H	272.0	0.1
2862.250000	---	36.32	54.00	17.68	500.0	200.0	H	259.0	0.2

**Remark: 1. Correction Factor = Antenna factor + Insertion loss (cable loss + amplifier gain)**

**2. Margin = Limit -MAX Peak/ Average**



802.11b CH11

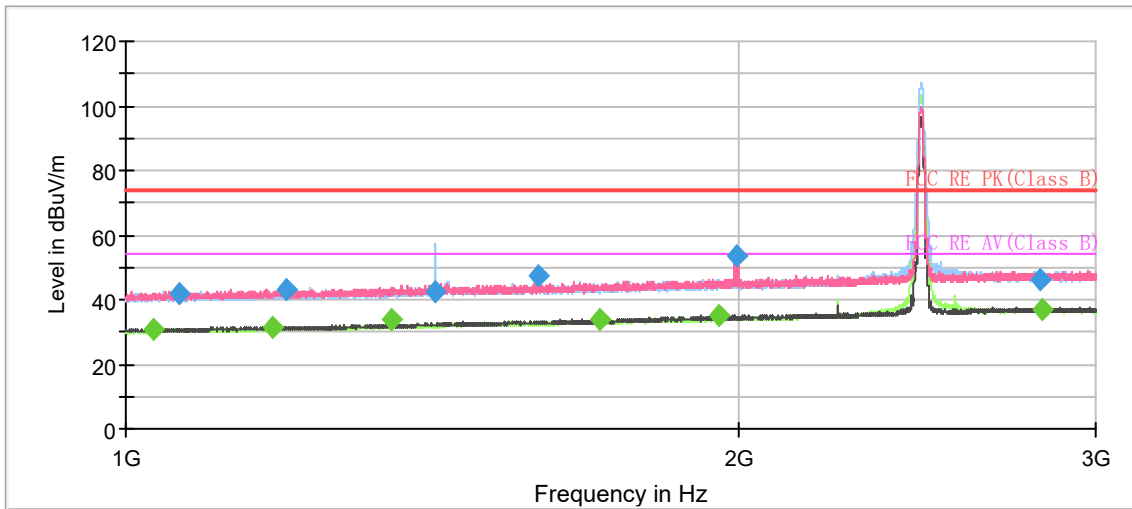

Note: The signal beyond the limit is carrier.  
Radiates Emission from 1GHz to 3GHz

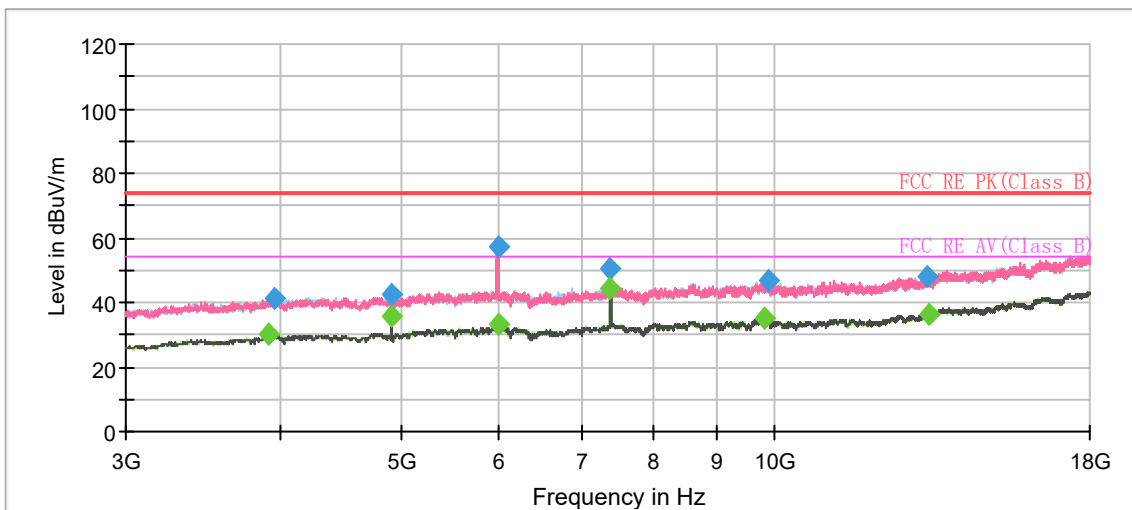

Radiates Emission from 3GHz to 18GHz

Frequency (MHz)	MaxPeak (dB $\mu$ V/m)	Average (dB $\mu$ V/m)	Limit (dB $\mu$ V/m)	Margin (dB)	Meas. Time (ms)	Height (cm)	Pol	Azimuth (deg)	Corr. (dB/m)
1031.500000	---	30.97	54.00	23.03	500.0	200.0	V	0.0	-8.9
1063.500000	41.95	---	74.00	32.05	500.0	100.0	V	231.0	-8.6
1180.000000	---	31.61	54.00	22.39	500.0	200.0	H	104.0	-7.9
1200.000000	42.99	---	74.00	31.01	500.0	200.0	V	248.0	-7.7
1350.000000	---	33.98	54.00	20.02	500.0	100.0	V	166.0	-6.8
1420.500000	42.65	---	74.00	31.35	500.0	200.0	H	85.0	-6.3
1596.000000	47.13	---	74.00	26.87	500.0	200.0	V	234.0	-5.5
1711.250000	---	33.87	54.00	20.13	500.0	200.0	V	325.0	-4.9
1956.250000	---	35.25	54.00	18.75	500.0	100.0	V	115.0	-3.7
1998.500000	53.68	---	74.00	20.32	500.0	200.0	V	238.0	-3.4
2815.500000	46.24	---	74.00	27.76	500.0	100.0	H	276.0	0.1
2825.500000	---	37.03	54.00	16.97	500.0	200.0	V	316.0	0.1
7387.500000	---	44.31	54.00	9.69	500.0	200.0	V	49.0	-0.7

**Remark: 1. Correction Factor = Antenna factor + Insertion loss (cable loss + amplifier gain)**

**2. Margin = Limit -MAX Peak/ Average**

802.11g CH1

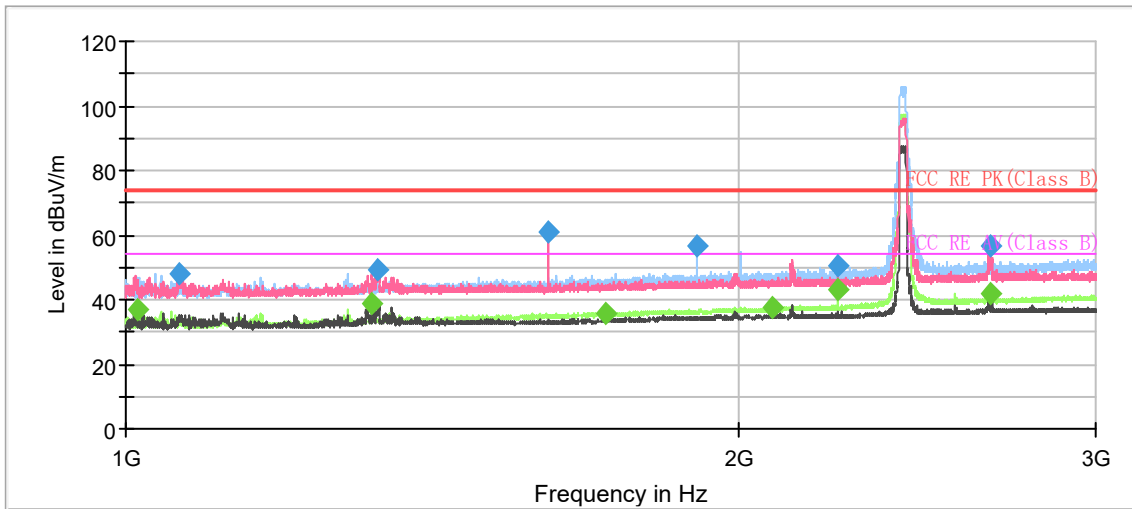

Note: The signal beyond the limit is carrier.  
Radiates Emission from 1GHz to 3GHz

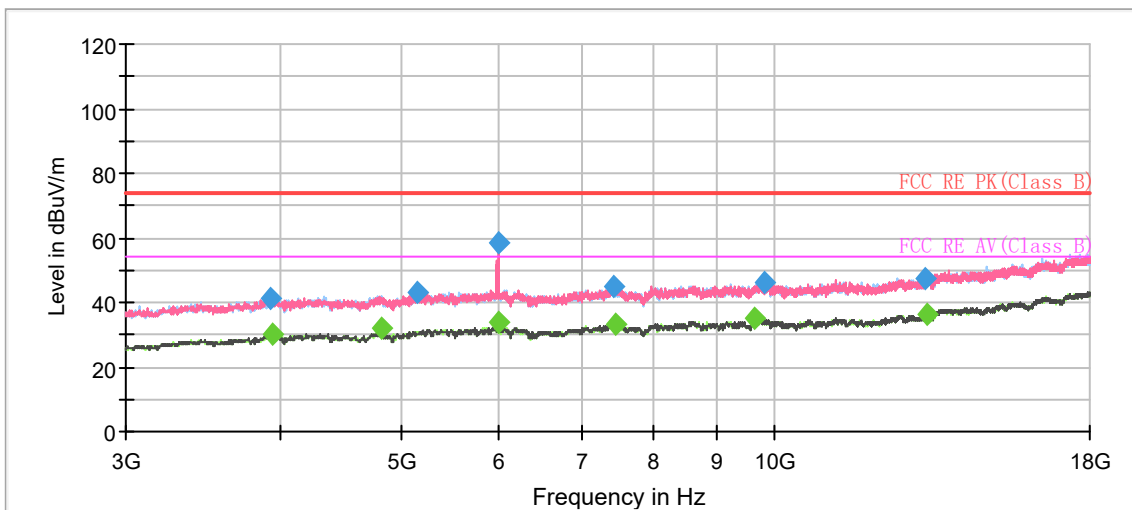

Radiates Emission from 3GHz to 18GHz

Frequency (MHz)	MaxPeak (dB $\mu$ V/m)	Average (dB $\mu$ V/m)	Limit (dB $\mu$ V/m)	Margin (dB)	Meas. Time (ms)	Height (cm)	Pol	Azimuth (deg)	Corr. (dB/m)
1014.250000	---	36.71	54.00	17.29	500.0	200.0	H	238.0	-9.0
1062.500000	48.20	---	74.00	25.80	500.0	200.0	V	247.0	-8.7
1322.250000	---	38.88	54.00	15.12	500.0	200.0	V	233.0	-7.0
1330.000000	49.25	---	74.00	24.75	500.0	100.0	V	262.0	-6.9
1614.500000	60.72	---	74.00	13.28	500.0	200.0	V	16.0	-5.4
1721.750000	---	35.78	54.00	18.22	500.0	200.0	H	14.0	-4.8
1909.000000	56.55	---	74.00	17.45	500.0	100.0	H	323.0	-3.9
2079.000000	---	37.46	54.00	16.54	500.0	200.0	H	10.0	-3.1
2239.750000	50.39	---	74.00	23.61	500.0	200.0	H	89.0	-2.4
2240.000000	---	43.25	54.00	10.75	500.0	200.0	H	89.0	-2.4
2661.250000	---	42.12	54.00	11.88	500.0	200.0	V	247.0	-0.3
2661.250000	56.74	---	74.00	17.26	500.0	200.0	V	247.0	-0.3

**Remark: 1. Correction Factor = Antenna factor + Insertion loss (cable loss + amplifier gain)**

**2. Margin = Limit -MAX Peak/ Average**

802.11g CH2

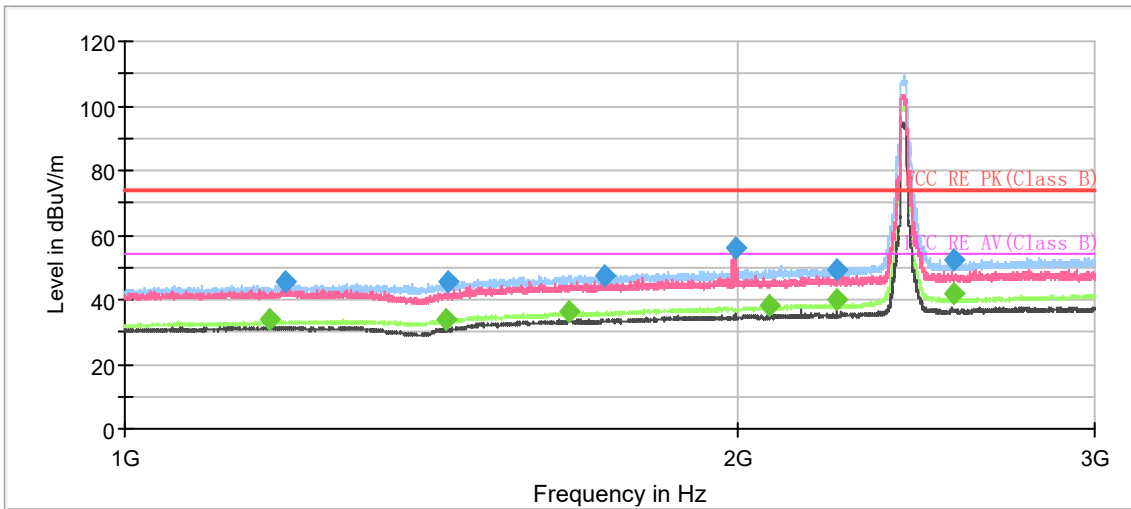

Note: The signal beyond the limit is carrier.  
Radiates Emission from 1GHz to 3GHz

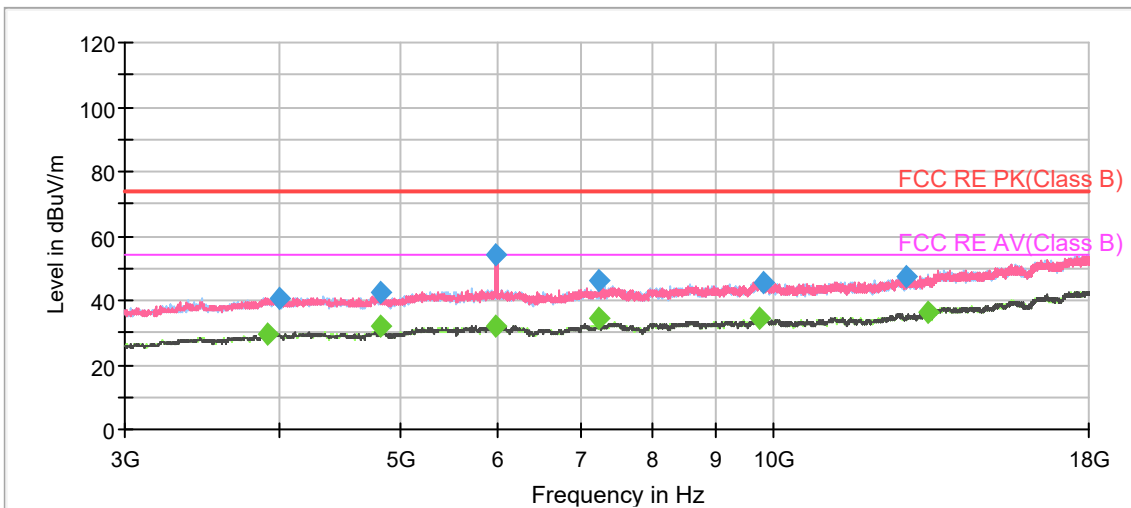

Radiates Emission from 3GHz to 18GHz

Frequency (MHz)	MaxPeak (dB $\mu$ V/m)	Average (dB $\mu$ V/m)	Limit (dB $\mu$ V/m)	Margin (dB)	Meas. Time (ms)	Height (cm)	Pol	Azimuth (deg)	Corr. (dB/m)
1178.250000	---	33.64	54.00	20.36	500.0	200.0	H	97.0	-7.9
1200.000000	45.34	---	74.00	28.66	500.0	100.0	H	152.0	-7.7
1439.000000	---	33.80	54.00	20.20	500.0	100.0	H	270.0	-6.2
1442.000000	45.72	---	74.00	28.28	500.0	200.0	H	61.0	-6.2
1653.000000	---	36.19	54.00	17.81	500.0	200.0	H	93.0	-5.2
1722.500000	47.61	---	74.00	26.39	500.0	200.0	H	83.0	-4.8
1995.750000	55.87	---	74.00	18.13	500.0	200.0	V	201.0	-3.5
2075.250000	---	37.88	54.00	16.12	500.0	100.0	H	113.0	-3.1
2239.000000	49.16	---	74.00	24.84	500.0	200.0	H	39.0	-2.4
2240.250000	---	40.01	54.00	13.99	500.0	100.0	H	0.0	-2.4
2560.000000	52.34	---	74.00	21.66	500.0	200.0	H	17.0	-0.9
2560.250000	---	41.91	54.00	12.09	500.0	200.0	H	21.0	-0.9

**Remark: 1. Correction Factor = Antenna factor + Insertion loss (cable loss + amplifier gain)**

**2. Margin = Limit –MAX Peak/ Average**

802.11g CH3

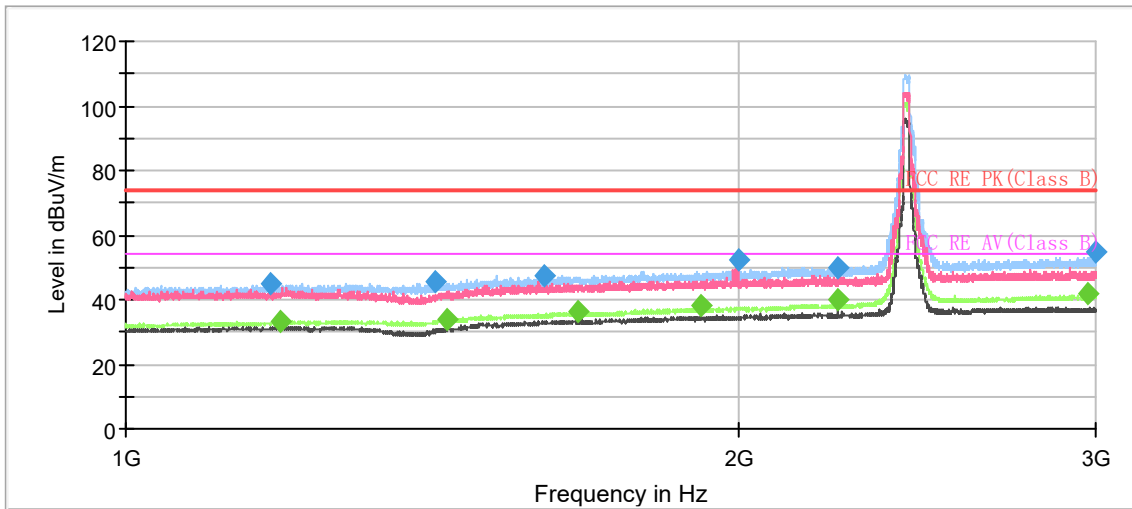

Note: The signal beyond the limit is carrier.  
Radiates Emission from 1GHz to 3GHz

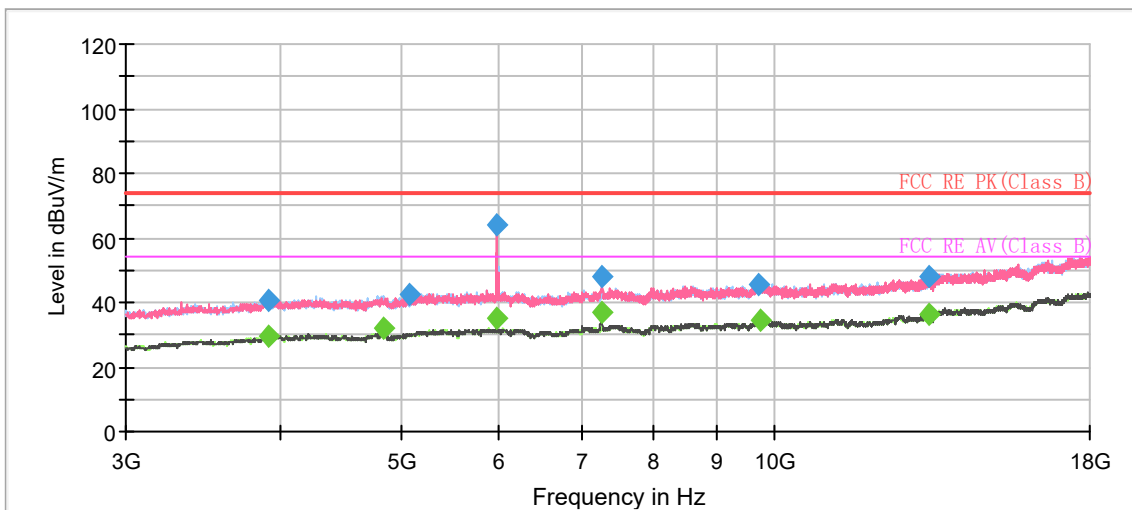

Radiates Emission from 3GHz to 18GHz

Frequency (MHz)	MaxPeak (dB $\mu$ V/m)	Average (dB $\mu$ V/m)	Limit (dB $\mu$ V/m)	Margin (dB)	Meas. Time (ms)	Height (cm)	Pol	Azimuth (deg)	Corr. (dB/m)
1177.750000	44.89	---	74.00	29.11	500.0	100.0	H	196.0	-7.9
1190.500000	---	33.33	54.00	20.67	500.0	200.0	H	120.0	-7.8
1419.250000	45.58	---	74.00	28.42	500.0	200.0	H	98.0	-6.3
1439.000000	---	33.86	54.00	20.14	500.0	100.0	H	238.0	-6.2
1605.750000	47.54	---	74.00	26.46	500.0	200.0	H	120.0	-5.5
1669.250000	---	36.07	54.00	17.93	500.0	200.0	H	61.0	-5.1
1920.250000	---	37.99	54.00	16.01	500.0	200.0	H	263.0	-3.9
2000.000000	52.18	---	74.00	21.82	500.0	100.0	V	142.0	-3.4
2240.000000	---	39.79	54.00	14.21	500.0	100.0	H	354.0	-2.4
2240.500000	49.81	---	74.00	24.19	500.0	100.0	H	318.0	-2.4
2972.500000	---	41.58	54.00	12.42	500.0	200.0	H	152.0	0.4
2998.000000	54.46	---	74.00	19.54	500.0	100.0	H	107.0	0.5
5971.875000	63.79	---	74.00	10.21	500.0	200.0	V	254.0	-2.0

**Remark: 1. Correction Factor = Antenna factor + Insertion loss (cable loss + amplifier gain)**

**2. Margin = Limit -MAX Peak/ Average**



802.11g CH4

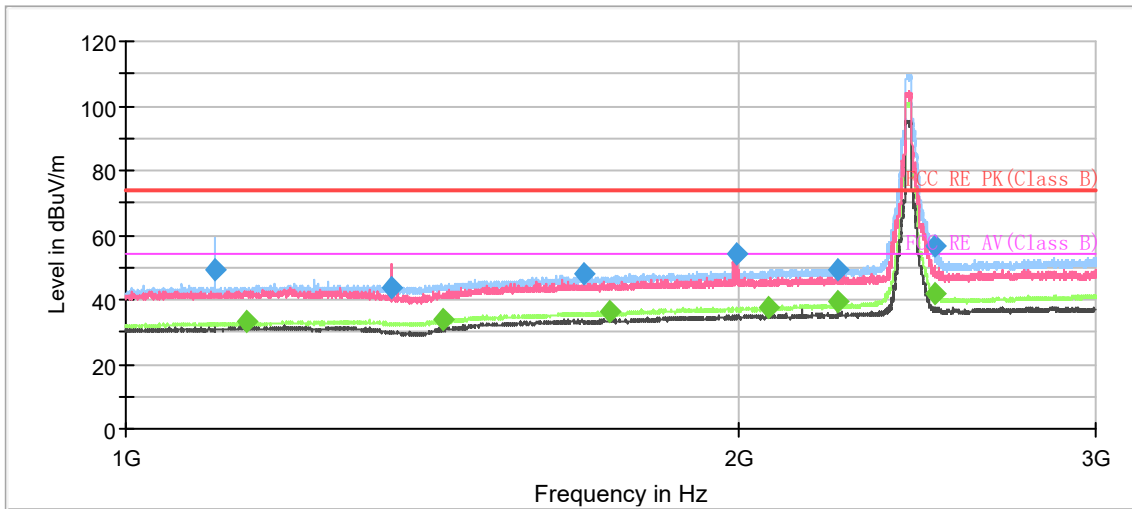

Note: The signal beyond the limit is carrier.  
Radiates Emission from 1GHz to 3GHz

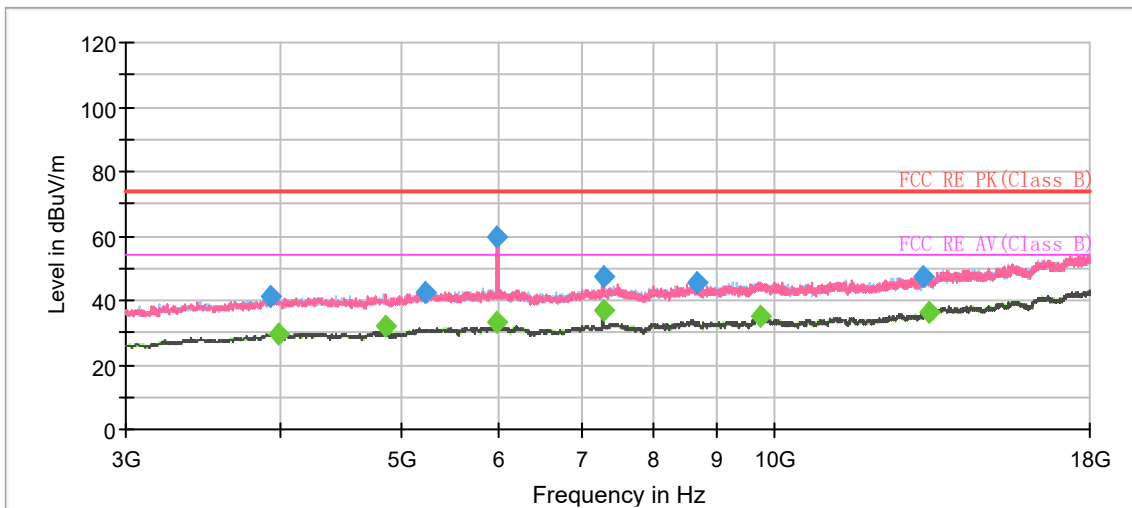

Radiates Emission from 3GHz to 18GHz

Frequency (MHz)	MaxPeak (dB $\mu$ V/m)	Average (dB $\mu$ V/m)	Limit (dB $\mu$ V/m)	Margin (dB)	Meas. Time (ms)	Height (cm)	Pol	Azimuth (deg)	Corr. (dB/m)
1106.250000	49.18	---	74.00	24.82	500.0	100.0	H	319.0	-8.3
1147.000000	---	33.16	54.00	20.84	500.0	100.0	H	276.0	-8.1
1351.750000	43.80	---	74.00	30.20	500.0	200.0	V	4.0	-6.8
1431.500000	---	33.78	54.00	20.22	500.0	200.0	H	16.0	-6.3
1678.750000	48.10	---	74.00	25.90	500.0	200.0	H	112.0	-5.0
1728.750000	---	36.12	54.00	17.88	500.0	200.0	H	108.0	-4.8
1999.750000	54.14	---	74.00	19.86	500.0	100.0	V	142.0	-3.4
2071.750000	---	37.71	54.00	16.29	500.0	200.0	H	152.0	-3.1
2240.250000	---	39.51	54.00	14.49	500.0	100.0	H	355.0	-2.4
2240.500000	49.39	---	74.00	24.61	500.0	100.0	H	351.0	-2.4
2498.250000	---	41.59	54.00	12.41	500.0	200.0	H	0.0	-1.2
2498.250000	56.54	---	74.00	17.46	500.0	200.0	H	0.0	-1.2

**Remark: 1. Correction Factor = Antenna factor + Insertion loss (cable loss + amplifier gain)**

**2. Margin = Limit - MAX Peak/ Average**

802.11g CH6

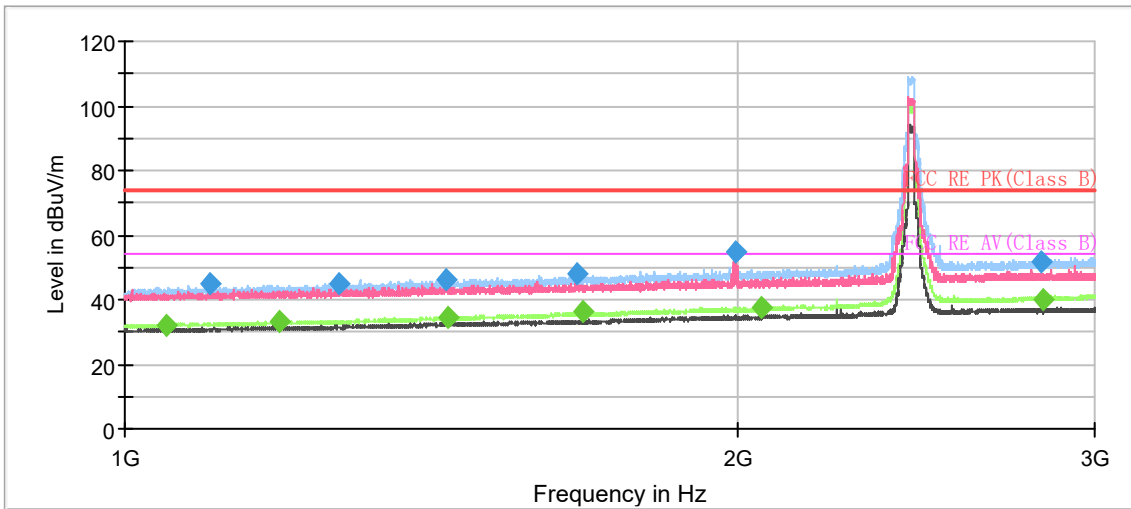

Note: The signal beyond the limit is carrier.  
Radiates Emission from 1GHz to 3GHz

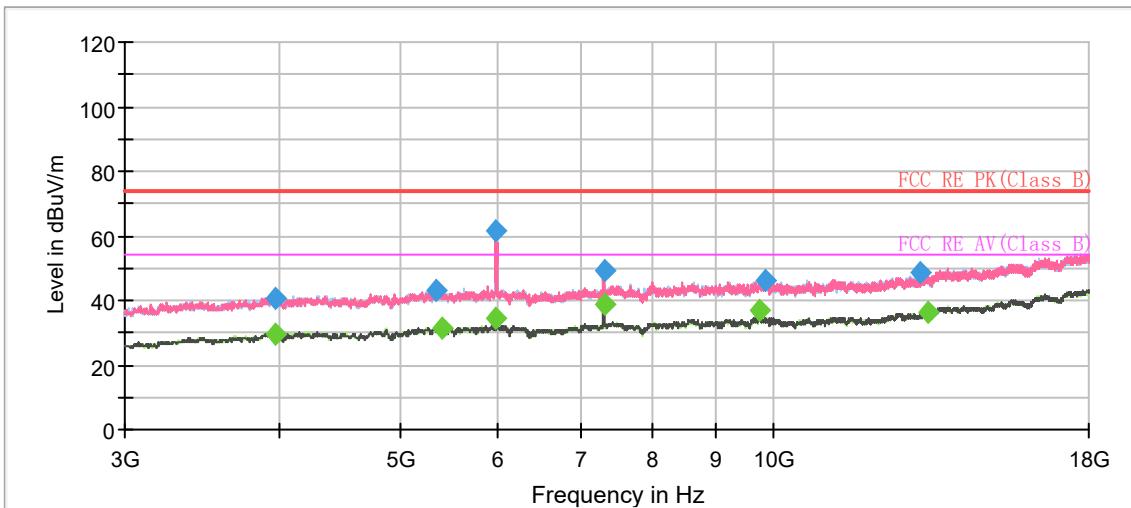

Radiates Emission from 3GHz to 18GHz

Frequency (MHz)	MaxPeak (dB $\mu$ V/m)	Average (dB $\mu$ V/m)	Limit (dB $\mu$ V/m)	Margin (dB)	Meas. Time (ms)	Height (cm)	Pol	Azimuth (deg)	Corr. (dB/m)
1047.250000	---	32.22	54.00	21.78	500.0	100.0	H	263.0	-8.7
1101.500000	44.62	---	74.00	29.38	500.0	100.0	H	258.0	-8.4
1191.000000	---	33.18	54.00	20.82	500.0	100.0	H	148.0	-7.8
1274.500000	45.12	---	74.00	28.88	500.0	200.0	H	15.0	-7.3
1438.750000	46.20	---	74.00	27.80	500.0	200.0	H	262.0	-6.2
1441.750000	---	34.49	54.00	19.51	500.0	200.0	H	220.0	-6.2
1669.750000	47.82	---	74.00	26.18	500.0	100.0	H	97.0	-5.1
1681.250000	---	36.08	54.00	17.92	500.0	200.0	H	225.0	-5.0
1998.750000	54.98	---	74.00	19.02	500.0	200.0	V	240.0	-3.4
2056.500000	---	37.67	54.00	16.33	500.0	200.0	H	66.0	-3.2
2820.750000	51.75	---	74.00	22.25	500.0	100.0	H	263.0	0.1
2830.750000	---	40.07	54.00	13.93	500.0	200.0	H	211.0	0.1

**Remark: 1. Correction Factor = Antenna factor + Insertion loss (cable loss + amplifier gain)**

**2. Margin = Limit -MAX Peak/ Average**

802.11g CH8

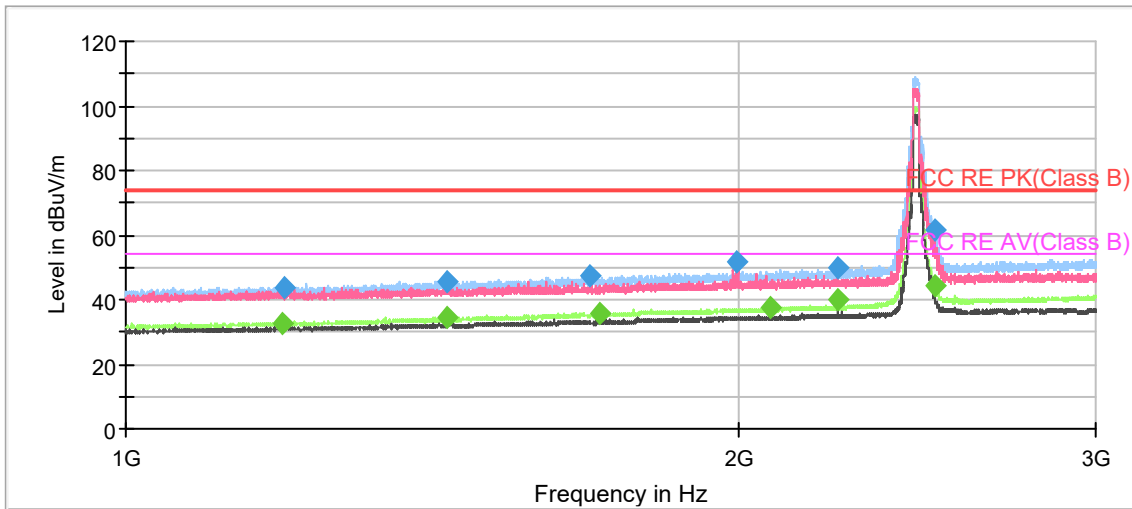

Note: The signal beyond the limit is carrier.  
Radiates Emission from 1GHz to 3GHz

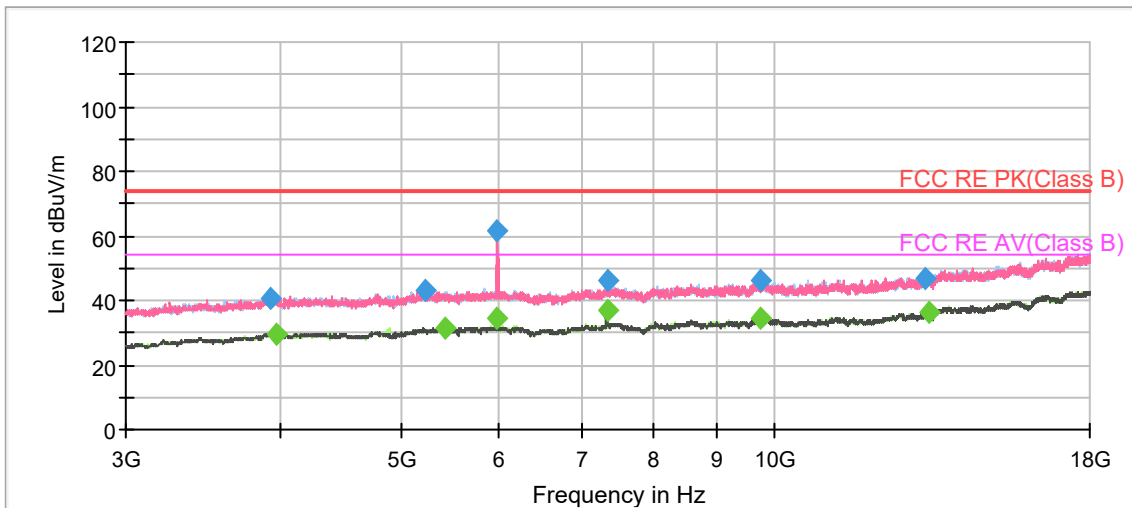

Radiates Emission from 3GHz to 18GHz

Frequency (MHz)	MaxPeak (dB $\mu$ V/m)	Average (dB $\mu$ V/m)	Limit (dB $\mu$ V/m)	Margin (dB)	Meas. Time (ms)	Height (cm)	Pol	Azimuth (deg)	Corr. (dB/m)
1193.250000	---	32.91	54.00	21.09	500.0	100.0	H	347.0	-7.8
1197.000000	43.90	---	74.00	30.10	500.0	100.0	H	195.0	-7.7
1439.250000	45.50	---	74.00	28.50	500.0	100.0	H	181.0	-6.2
1440.000000	---	34.45	54.00	19.55	500.0	100.0	H	0.0	-6.2
1691.750000	47.22	---	74.00	26.78	500.0	100.0	H	352.0	-5.0
1711.500000	---	35.68	54.00	18.32	500.0	100.0	H	342.0	-4.9
1997.750000	51.56	---	74.00	22.44	500.0	100.0	V	193.0	-3.4
2076.750000	---	37.24	54.00	16.76	500.0	100.0	H	352.0	-3.1
2239.750000	49.97	---	74.00	24.03	500.0	100.0	H	54.0	-2.4
2240.000000	---	39.70	54.00	14.30	500.0	100.0	H	288.0	-2.4
2500.500000	61.53	---	74.00	12.47	500.0	100.0	H	20.0	-1.2
2500.750000	---	44.60	54.00	9.40	500.0	100.0	H	283.0	-1.2

**Remark: 1. Correction Factor = Antenna factor + Insertion loss (cable loss + amplifier gain)**

**2. Margin = Limit - MAX Peak/ Average**

802.11g CH9

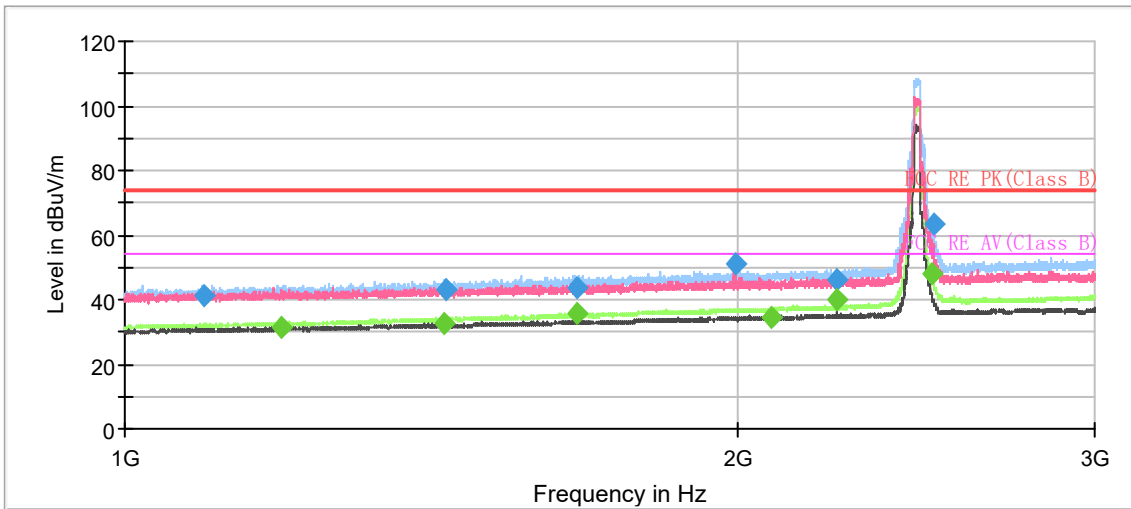

Note: The signal beyond the limit is carrier.  
Radiates Emission from 1GHz to 3GHz

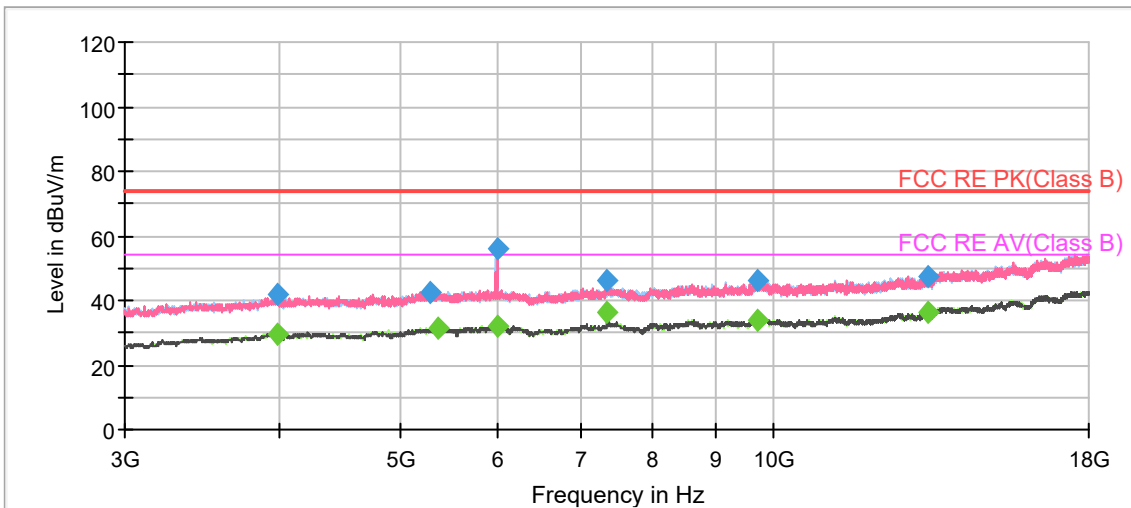

Radiates Emission from 3GHz to 18GHz

Frequency (MHz)	MaxPeak (dB $\mu$ V/m)	Average (dB $\mu$ V/m)	Limit (dB $\mu$ V/m)	Margin (dB)	Meas. Time (ms)	Height (cm)	Pol	Azimuth (deg)	Corr. (dB/m)
1093.816250	41.46	---	74.00	32.54	500.0	100.0	H	91.0	-8.5
1193.313750	---	31.09	54.00	22.91	500.0	200.0	H	81.0	-7.8
1435.055000	---	32.42	54.00	21.58	500.0	100.0	H	119.0	-6.3
1438.753750	43.13	---	74.00	30.87	500.0	200.0	H	8.0	-6.3
1668.521250	---	35.50	54.00	18.50	500.0	100.0	H	119.0	-5.1
1668.521250	43.73	---	74.00	30.27	500.0	200.0	H	119.0	-5.1
1996.747500	51.20	---	74.00	22.80	500.0	200.0	V	94.0	-3.5
2079.241250	---	34.18	54.00	19.82	500.0	100.0	H	124.0	-3.1
2239.660000	46.37	---	74.00	27.63	500.0	100.0	H	77.0	-2.4
2239.877500	---	39.88	54.00	14.12	500.0	100.0	H	243.0	-2.4
2494.548750	---	47.76	54.00	6.24	500.0	100.0	H	273.0	-1.2
2500.452500	63.32	---	74.00	10.68	500.0	100.0	H	268.0	-1.2

**Remark: 1. Correction Factor = Antenna factor + Insertion loss (cable loss + amplifier gain)**

**2. Margin = Limit - MAX Peak/ Average**



802.11g CH10

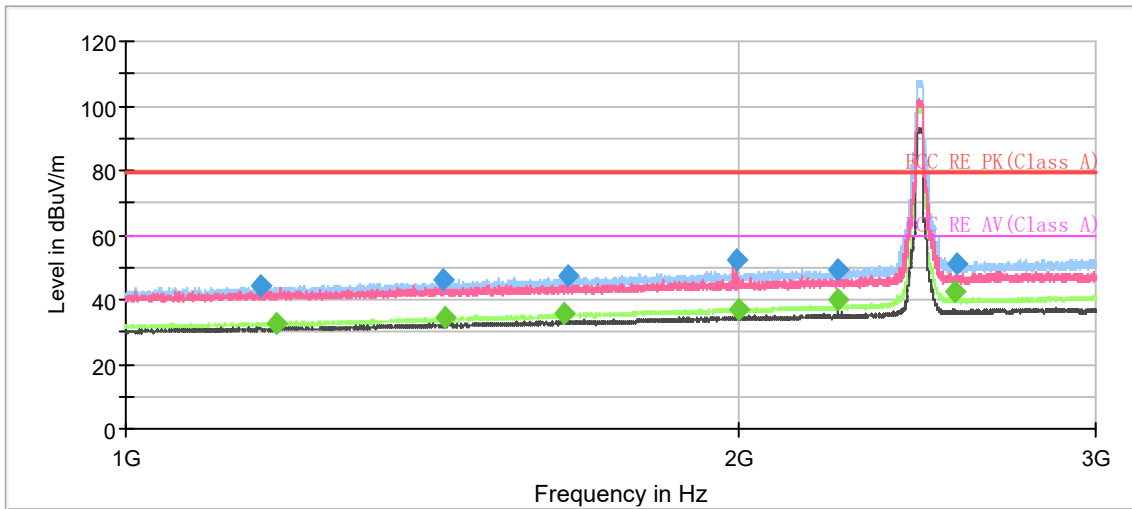

Note: The signal beyond the limit is carrier.  
Radiates Emission from 1GHz to 3GHz

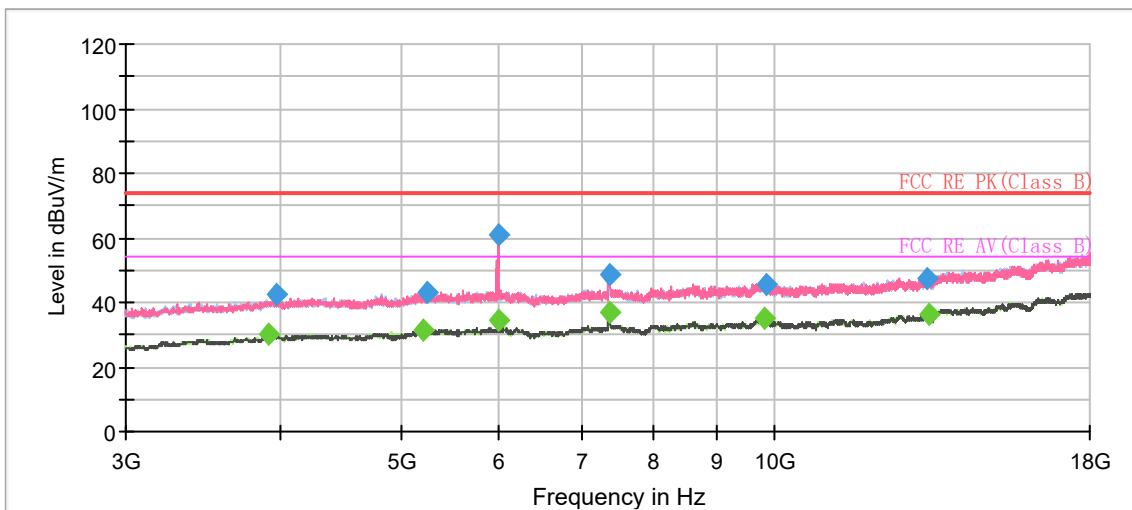

Radiates Emission from 3GHz to 18GHz

Frequency (MHz)	MaxPeak (dB $\mu$ V/m)	Average (dB $\mu$ V/m)	Limit (dB $\mu$ V/m)	Margin (dB)	Meas. Time (ms)	Height (cm)	Pol	Azimuth (deg)	Corr. (dB/m)
1166.000000	44.49	---	79.50	35.01	500.0	100.0	H	172.0	-8.0
1186.750000	---	32.89	59.50	26.61	500.0	100.0	H	106.0	-7.8
1432.000000	46.12	---	79.50	33.38	500.0	100.0	H	247.0	-6.3
1437.250000	---	34.51	59.50	24.99	500.0	100.0	H	238.0	-6.2
1643.750000	---	35.85	59.50	23.65	500.0	100.0	H	238.0	-5.2
1649.250000	47.45	---	79.50	32.05	500.0	100.0	H	307.0	-5.2
1997.750000	52.08	---	79.50	27.42	500.0	100.0	V	59.0	-3.4
2003.000000	---	36.99	59.50	22.51	500.0	100.0	H	270.0	-3.4
2240.000000	49.15	---	79.50	30.35	500.0	100.0	H	238.0	-2.4
2240.250000	---	40.04	59.50	19.46	500.0	100.0	H	233.0	-2.4
2560.250000	---	42.26	59.50	17.24	500.0	100.0	H	315.0	-0.9
2560.750000	51.14	---	79.50	28.36	500.0	100.0	H	320.0	-0.9

**Remark: 1. Correction Factor = Antenna factor + Insertion loss (cable loss + amplifier gain)**

**2. Margin = Limit - MAX Peak/ Average**

802.11g CH11

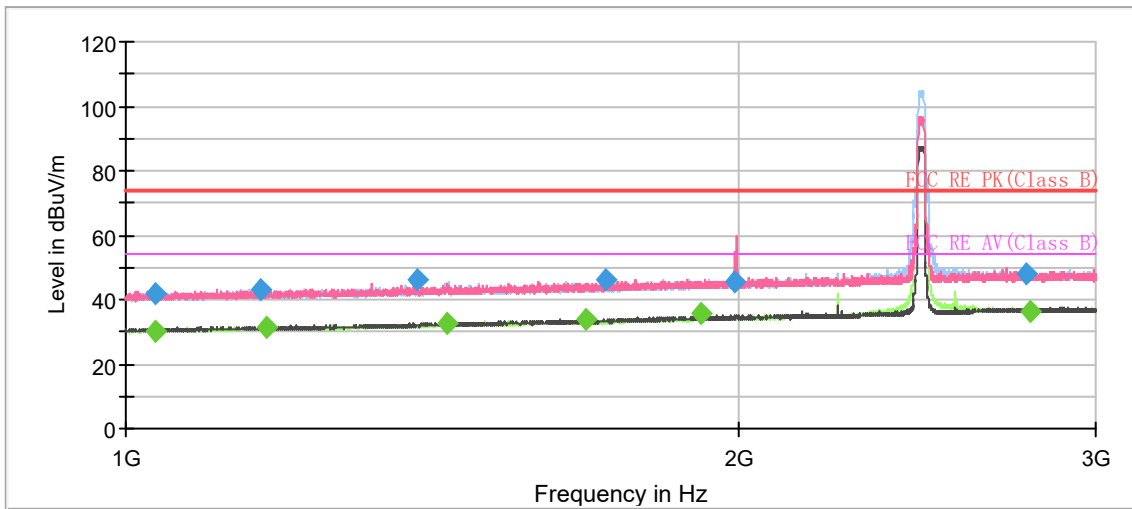

Note: The signal beyond the limit is carrier.  
Radiates Emission from 1GHz to 3GHz

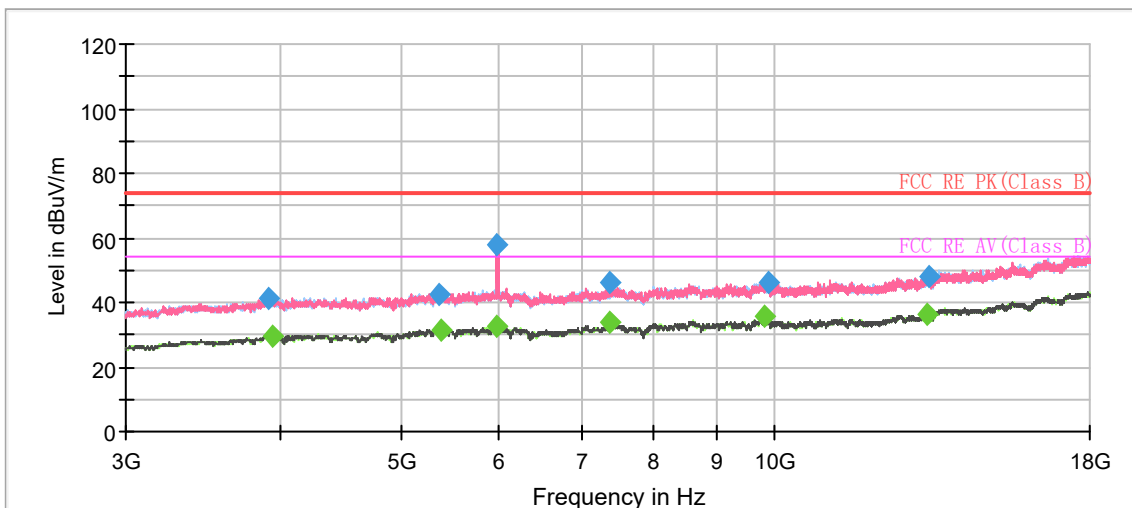

Radiates Emission from 3GHz to 18GHz

Frequency (MHz)	MaxPeak (dB $\mu$ V/m)	Average (dB $\mu$ V/m)	Limit (dB $\mu$ V/m)	Margin (dB)	Meas. Time (ms)	Height (cm)	Pol	Azimuth (deg)	Corr. (dB/m)
1033.500000	42.06	---	74.00	31.94	500.0	100.0	V	342.0	-8.8
1034.250000	---	30.42	54.00	23.58	500.0	200.0	H	84.0	-8.8
1165.250000	43.15	---	74.00	30.85	500.0	100.0	H	73.0	-8.0
1171.750000	---	31.56	54.00	22.44	500.0	100.0	V	219.0	-7.9
1392.000000	45.92	---	74.00	28.08	500.0	100.0	H	259.0	-6.5
1440.500000	---	32.73	54.00	21.27	500.0	100.0	H	287.0	-6.2
1685.750000	---	33.86	54.00	20.14	500.0	200.0	V	34.0	-5.0
1722.750000	45.97	---	74.00	28.03	500.0	100.0	V	320.0	-4.8
1919.750000	---	35.77	54.00	18.23	500.0	100.0	V	265.0	-3.9
1995.250000	45.68	---	74.00	28.32	500.0	200.0	H	270.0	-3.5
2775.750000	47.78	---	74.00	26.22	500.0	200.0	V	186.0	0.0
2787.750000	---	36.39	54.00	17.61	500.0	100.0	H	36.0	0.0

**Remark: 1. Correction Factor = Antenna factor + Insertion loss (cable loss + amplifier gain)**

**2. Margin = Limit - MAX Peak/ Average**

802.11n (HT20) CH1

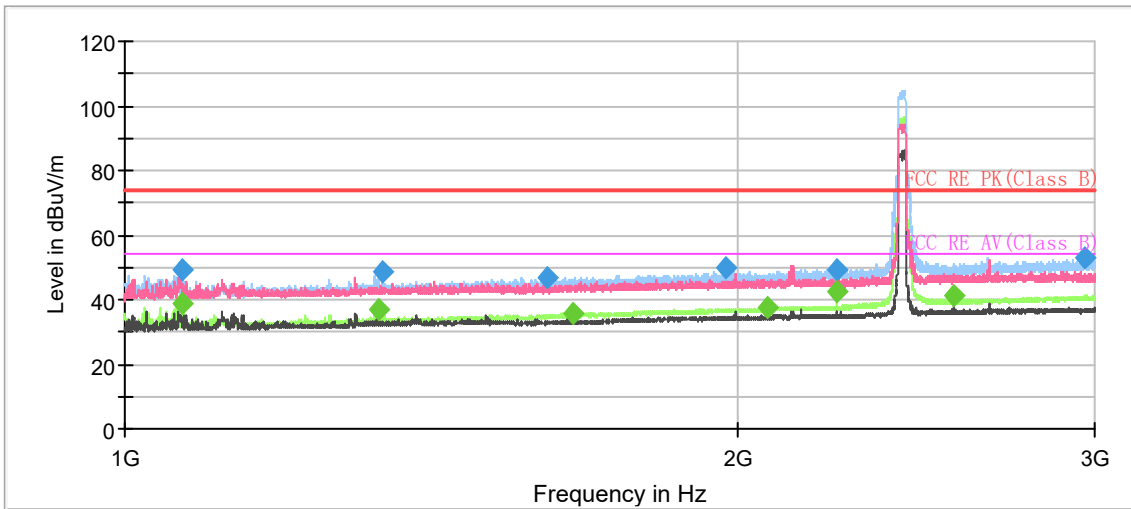

Note: The signal beyond the limit is carrier.  
Radiates Emission from 1GHz to 3GHz

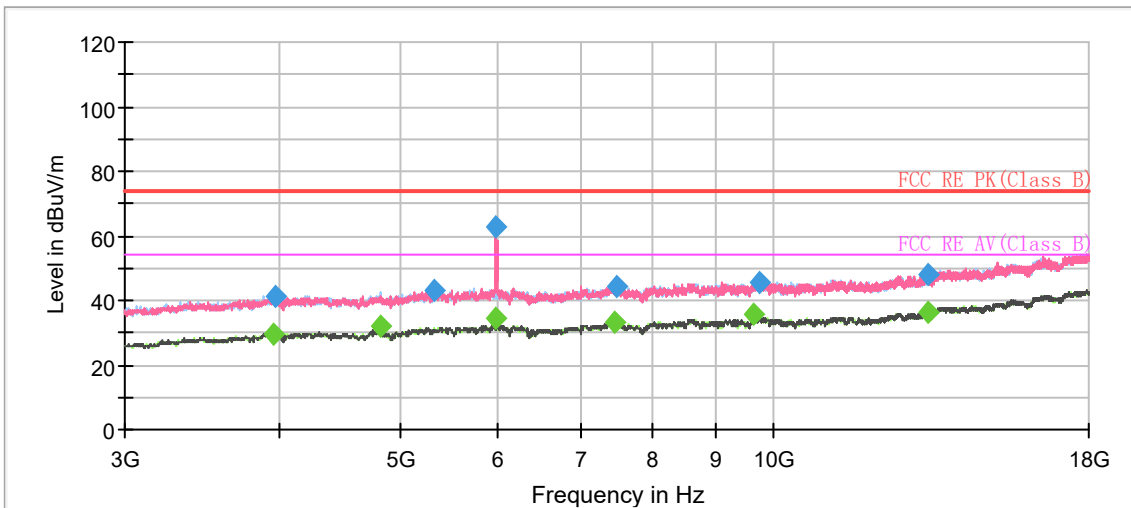

Radiates Emission from 3GHz to 18GHz

Frequency (MHz)	MaxPeak (dB $\mu$ V/m)	Average (dB $\mu$ V/m)	Limit (dB $\mu$ V/m)	Margin (dB)	Meas. Time (ms)	Height (cm)	Pol	Azimuth (deg)	Corr. (dB/m)
1067.000000	49.17	---	74.00	24.83	500.0	200.0	H	252.0	-8.6
1067.250000	---	38.53	54.00	15.47	500.0	200.0	H	252.0	-8.6
1331.750000	---	36.86	54.00	17.14	500.0	200.0	H	233.0	-6.9
1338.750000	48.47	---	74.00	25.53	500.0	200.0	H	233.0	-6.9
1614.000000	47.07	---	74.00	26.93	500.0	200.0	H	8.0	-5.4
1661.000000	---	35.76	54.00	18.24	500.0	200.0	H	0.0	-5.1
1973.250000	49.77	---	74.00	24.23	500.0	200.0	H	21.0	-3.6
2072.500000	---	37.24	54.00	16.76	500.0	200.0	H	0.0	-3.1
2239.750000	---	42.76	54.00	11.24	500.0	200.0	H	71.0	-2.4
2240.750000	49.25	---	74.00	24.75	500.0	200.0	H	81.0	-2.4
2560.000000	---	41.46	54.00	12.54	500.0	200.0	H	40.0	-0.9
2969.500000	52.98	---	74.00	21.02	500.0	200.0	H	40.0	0.4

**Remark: 1. Correction Factor = Antenna factor + Insertion loss (cable loss + amplifier gain)**

**2. Margin = Limit –MAX Peak/ Average**

802.11n (HT20) CH2

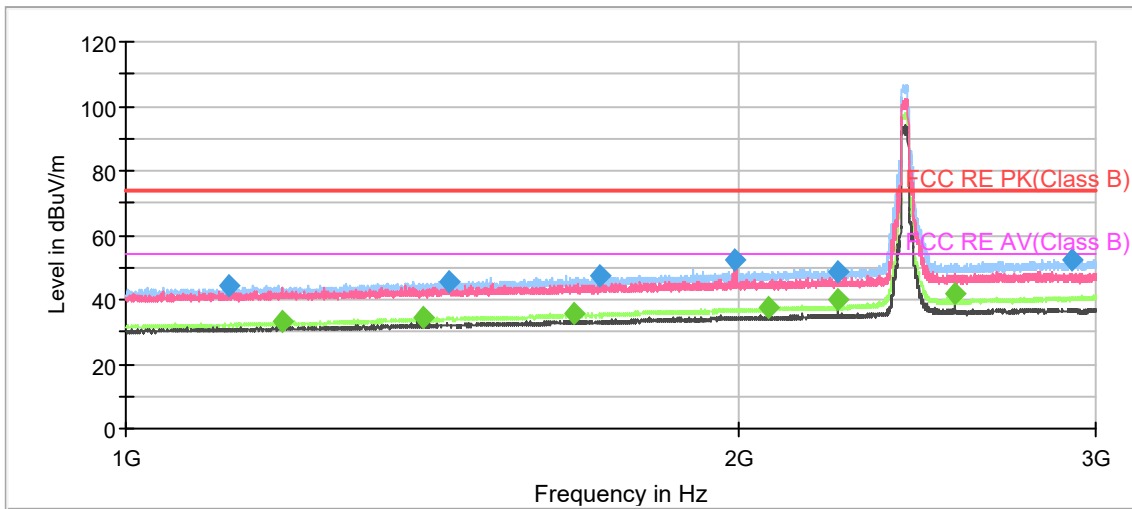

Note: The signal beyond the limit is carrier.  
Radiates Emission from 1GHz to 3GHz

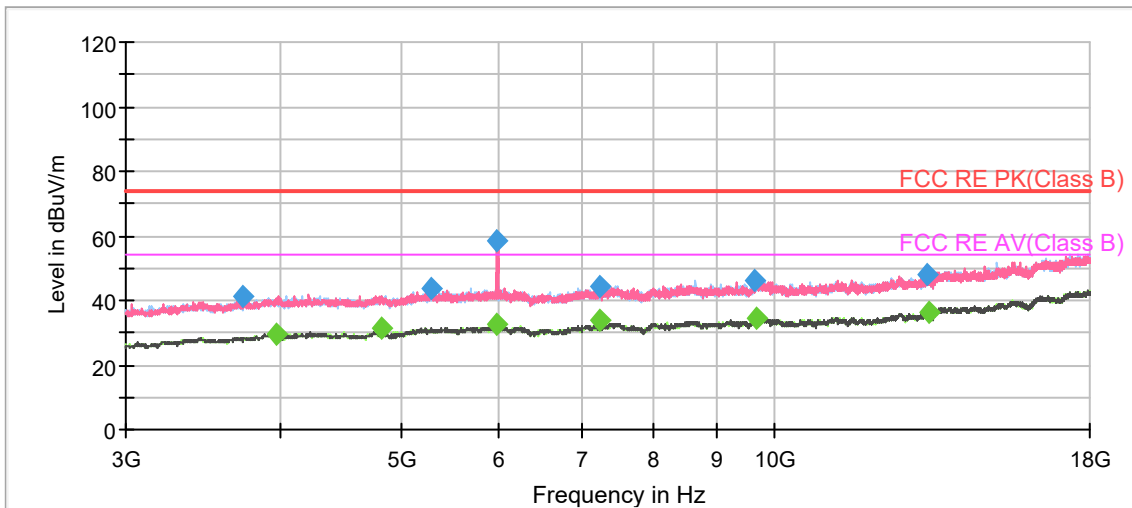

Radiates Emission from 3GHz to 18GHz

Frequency (MHz)	MaxPeak (dB $\mu$ V/m)	Average (dB $\mu$ V/m)	Limit (dB $\mu$ V/m)	Margin (dB)	Meas. Time (ms)	Height (cm)	Pol	Azimuth (deg)	Corr. (dB/m)
1123.000000	44.24	---	74.00	29.76	500.0	200.0	H	334.0	-8.2
1195.500000	---	33.05	54.00	20.95	500.0	200.0	H	186.0	-7.8
1402.250000	---	34.34	54.00	19.66	500.0	100.0	H	191.0	-6.5
1441.500000	45.66	---	74.00	28.34	500.0	100.0	H	195.0	-6.2
1660.500000	---	35.97	54.00	18.03	500.0	200.0	H	342.0	-5.1
1712.000000	47.23	---	74.00	26.77	500.0	100.0	H	172.0	-4.9
1994.250000	52.56	---	74.00	21.44	500.0	100.0	V	136.0	-3.5
2071.250000	---	37.24	54.00	16.76	500.0	200.0	H	154.0	-3.1
2240.000000	---	40.21	54.00	13.79	500.0	200.0	H	287.0	-2.4
2240.000000	48.73	---	74.00	25.27	500.0	100.0	H	287.0	-2.4
2560.000000	---	42.04	54.00	11.96	500.0	200.0	H	34.0	-0.9
2920.000000	52.60	---	74.00	21.40	500.0	100.0	H	150.0	0.3

**Remark: 1. Correction Factor = Antenna factor + Insertion loss (cable loss + amplifier gain)**

**2. Margin = Limit –MAX Peak/ Average**



802.11n (HT20) CH6

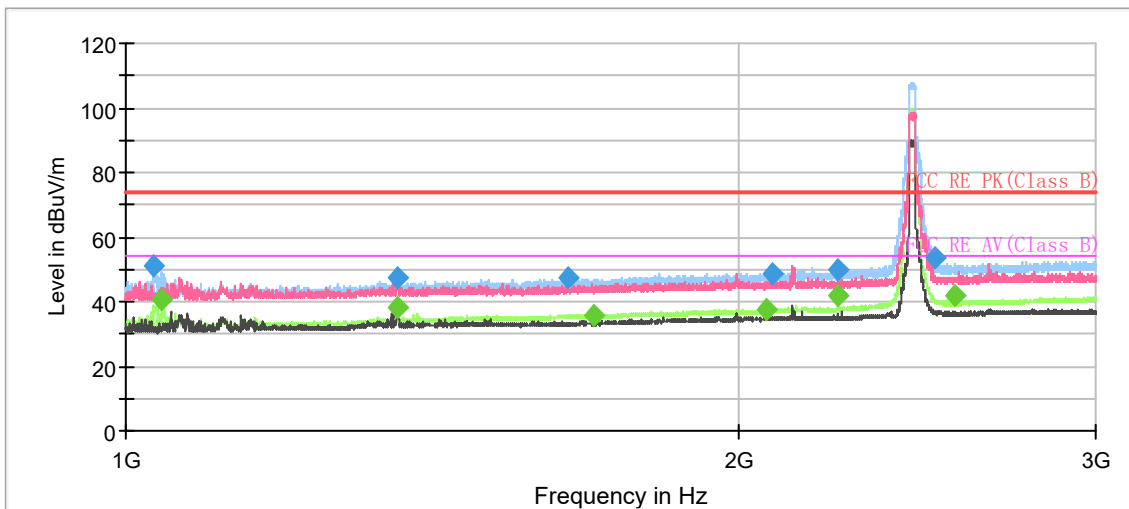

Note: The signal beyond the limit is carrier.  
Radiates Emission from 1GHz to 3GHz

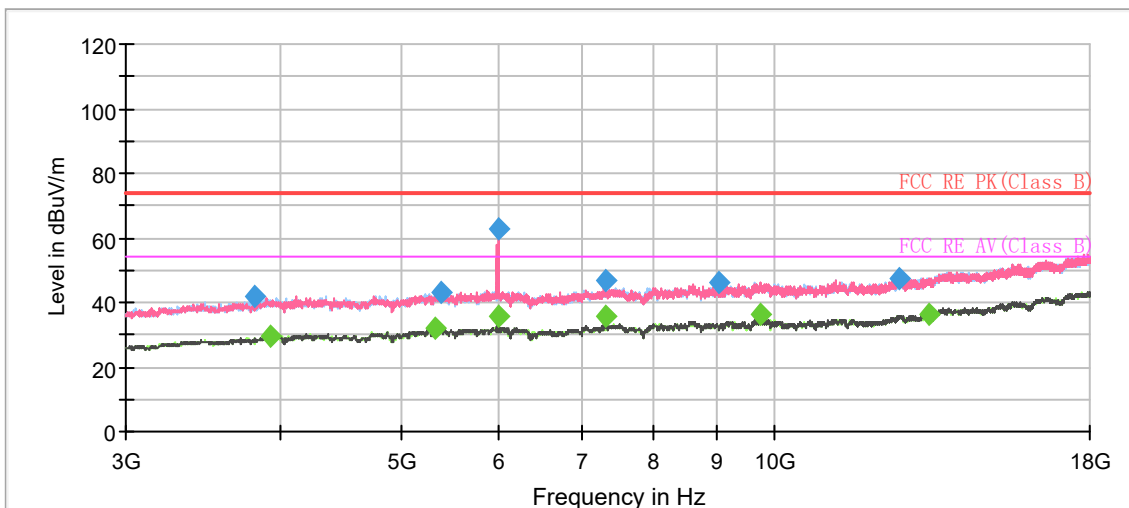

Radiates Emission from 3GHz to 18GHz

Frequency (MHz)	MaxPeak (dB $\mu$ V/m)	Average (dB $\mu$ V/m)	Limit (dB $\mu$ V/m)	Margin (dB)	Meas. Time (ms)	Height (cm)	Pol	Azimuth (deg)	Corr. (dB/m)
1032.250000	51.01	---	74.00	22.99	500.0	200.0	H	240.0	-8.9
1041.750000	---	40.47	54.00	13.53	500.0	200.0	H	240.0	-8.8
1359.500000	---	38.02	54.00	15.98	500.0	200.0	V	235.0	-6.7
1359.500000	47.68	---	74.00	26.32	500.0	200.0	V	235.0	-6.7
1651.000000	47.59	---	74.00	26.41	500.0	100.0	H	282.0	-5.2
1697.500000	---	35.89	54.00	18.11	500.0	100.0	H	348.0	-4.9
2065.750000	---	37.70	54.00	16.30	500.0	200.0	H	29.0	-3.1
2078.000000	48.91	---	74.00	25.09	500.0	100.0	H	0.0	-3.1
2240.250000	49.82	---	74.00	24.18	500.0	200.0	H	92.0	-2.4
2240.250000	---	42.04	54.00	11.96	500.0	100.0	H	87.0	-2.4
2499.500000	53.28	---	74.00	20.72	500.0	100.0	H	98.0	-1.2
2560.250000	---	42.14	54.00	11.86	500.0	100.0	H	98.0	-0.9

**Remark: 1. Correction Factor = Antenna factor + Insertion loss (cable loss + amplifier gain)**

**2. Margin = Limit - MAX Peak/ Average**

802.11n (HT20) CH10

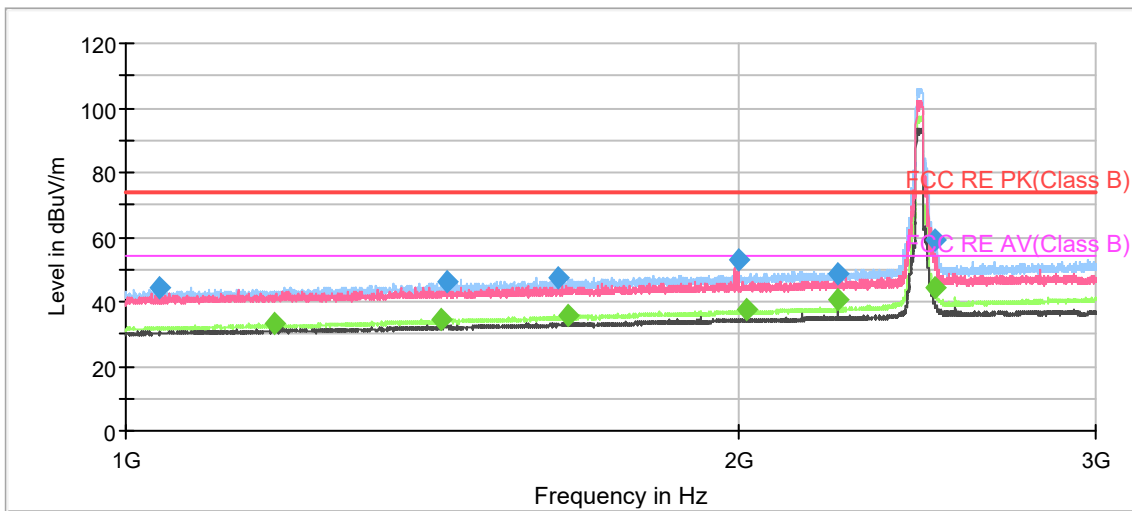

Note: The signal beyond the limit is carrier.  
Radiates Emission from 1GHz to 3GHz

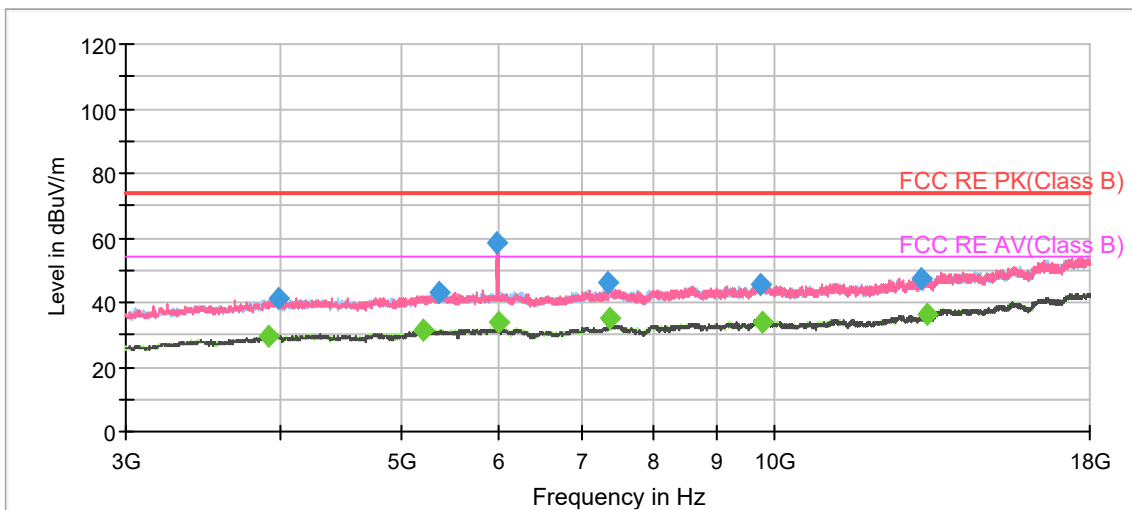

Radiates Emission from 3GHz to 18GHz

Frequency (MHz)	MaxPeak (dB $\mu$ V/m)	Average (dB $\mu$ V/m)	Limit (dB $\mu$ V/m)	Margin (dB)	Meas. Time (ms)	Height (cm)	Pol	Azimuth (deg)	Corr. (dB/m)
1039.500000	44.38	---	74.00	29.62	500.0	100.0	H	107.0	-8.8
1183.500000	---	33.04	54.00	20.96	500.0	100.0	H	342.0	-7.8
1430.750000	---	34.45	54.00	19.55	500.0	200.0	H	352.0	-6.3
1440.000000	45.97	---	74.00	28.03	500.0	100.0	H	295.0	-6.2
1633.250000	47.15	---	74.00	26.85	500.0	200.0	H	243.0	-5.3
1650.000000	---	35.92	54.00	18.08	500.0	200.0	H	342.0	-5.2
2000.250000	52.69	---	74.00	21.31	500.0	100.0	V	195.0	-3.4
2020.250000	---	37.29	54.00	16.71	500.0	200.0	H	310.0	-3.3
2240.000000	---	40.61	54.00	13.39	500.0	200.0	H	72.0	-2.4
2240.500000	48.78	---	74.00	25.22	500.0	200.0	H	232.0	-2.4
2499.250000	59.24	---	74.00	14.76	500.0	100.0	H	261.0	-1.2
2500.250000	---	44.21	54.00	9.79	500.0	200.0	H	72.0	-1.2

**Remark: 1. Correction Factor = Antenna factor + Insertion loss (cable loss + amplifier gain)**

**2. Margin = Limit - MAX Peak/ Average**

802.11n (HT20) CH11

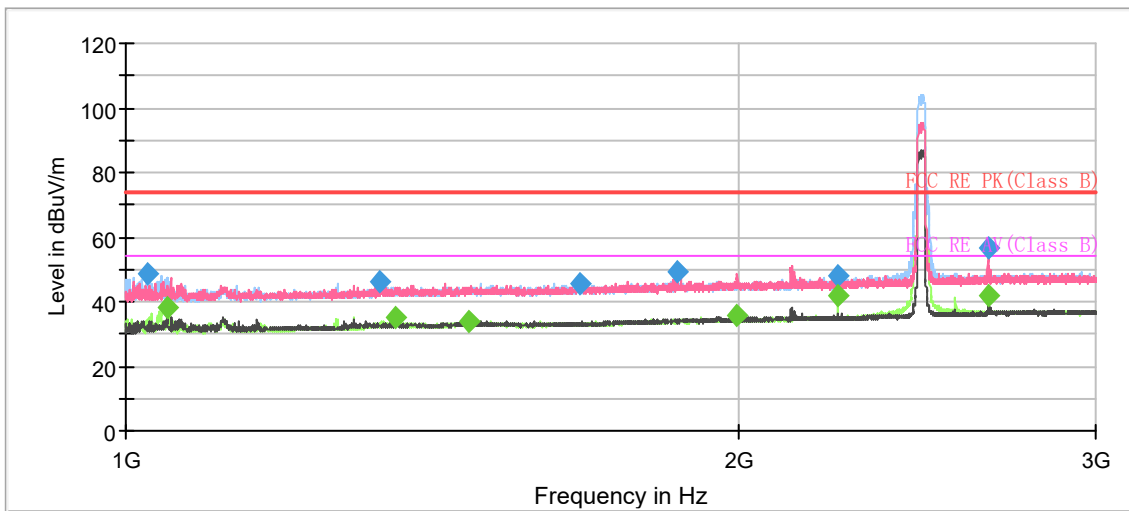

Note: The signal beyond the limit is carrier.  
Radiates Emission from 1GHz to 3GHz

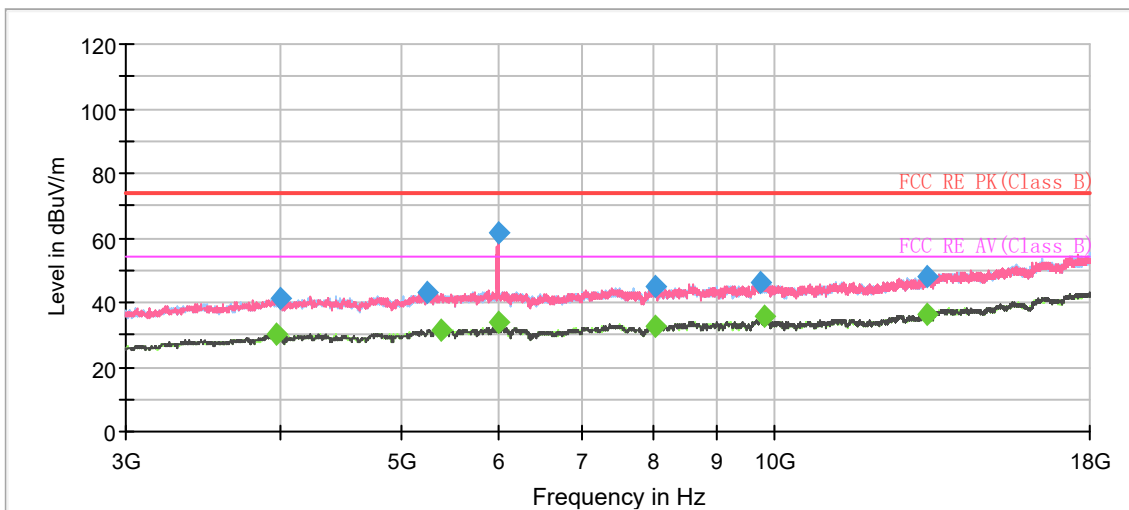

Radiates Emission from 3GHz to 18GHz

Frequency (MHz)	MaxPeak (dB $\mu$ V/m)	Average (dB $\mu$ V/m)	Limit (dB $\mu$ V/m)	Margin (dB)	Meas. Time (ms)	Height (cm)	Pol	Azimuth (deg)	Corr. (dB/m)
1024.000000	48.77	---	74.00	25.23	500.0	200.0	H	161.0	-8.9
1048.000000	---	38.06	54.00	15.94	500.0	200.0	H	262.0	-8.7
1332.750000	46.05	---	74.00	27.95	500.0	100.0	H	171.0	-6.9
1357.750000	---	35.15	54.00	18.85	500.0	200.0	V	137.0	-6.8
1474.250000	---	34.11	54.00	19.89	500.0	100.0	H	230.0	-6.1
1672.250000	45.51	---	74.00	28.49	500.0	200.0	V	316.0	-5.0
1866.000000	48.98	---	74.00	25.02	500.0	100.0	V	51.0	-4.1
1999.000000	---	35.75	54.00	18.25	500.0	100.0	V	189.0	-3.4
2240.000000	47.72	---	74.00	26.28	500.0	200.0	H	76.0	-2.4
2240.000000	---	42.00	54.00	12.00	500.0	200.0	H	76.0	-2.4
2655.500000	56.92	---	74.00	17.08	500.0	200.0	V	213.0	-0.4
2655.750000	---	41.85	54.00	12.15	500.0	200.0	V	213.0	-0.4

**Remark: 1. Correction Factor = Antenna factor + Insertion loss (cable loss + amplifier gain)**

**2. Margin = Limit –MAX Peak/ Average**

802.11n (HT40) CH3

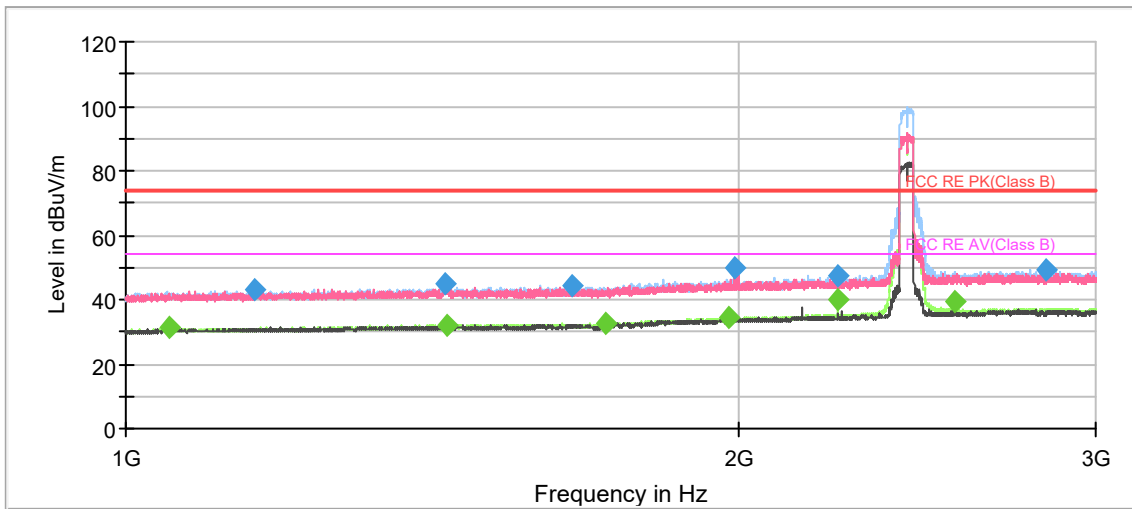

Note: The signal beyond the limit is carrier.  
Radiates Emission from 1GHz to 3GHz

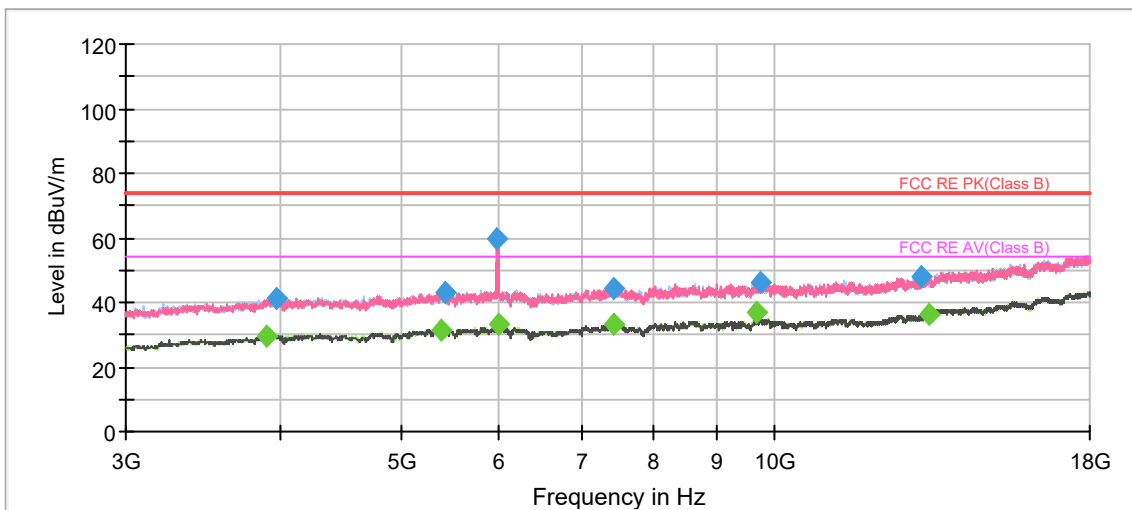

Radiates Emission from 3GHz to 18GHz

Frequency (MHz)	MaxPeak (dB $\mu$ V/m)	Average (dB $\mu$ V/m)	Limit (dB $\mu$ V/m)	Margin (dB)	Meas. Time (ms)	Height (cm)	Pol	Azimuth (deg)	Corr. (dB/m)
1050.000000	---	31.33	54.00	22.67	500.0	200.0	V	68.0	-8.7
1156.500000	42.84	---	74.00	31.16	500.0	200.0	H	98.0	-8.0
1436.750000	44.72	---	74.00	29.28	500.0	200.0	H	30.0	-6.2
1440.500000	---	32.07	54.00	21.93	500.0	100.0	H	165.0	-6.2
1656.000000	44.13	---	74.00	29.87	500.0	100.0	V	93.0	-5.1
1722.000000	---	32.60	54.00	21.40	500.0	200.0	H	71.0	-4.8
1978.500000	---	34.62	54.00	19.38	500.0	200.0	H	21.0	-3.5
1994.250000	49.99	---	74.00	24.01	500.0	100.0	V	129.0	-3.5
2240.000000	---	39.84	54.00	14.16	500.0	200.0	H	30.0	-2.4
2240.000000	47.21	---	74.00	26.79	500.0	100.0	H	0.0	-2.4
2560.000000	---	39.59	54.00	14.41	500.0	100.0	H	359.0	-0.9
2838.250000	49.27	---	74.00	24.73	500.0	200.0	H	284.0	0.1

**Remark: 1. Correction Factor = Antenna factor + Insertion loss (cable loss + amplifier gain)**

**2. Margin = Limit - MAX Peak/ Average**



802.11n (HT40) CH4

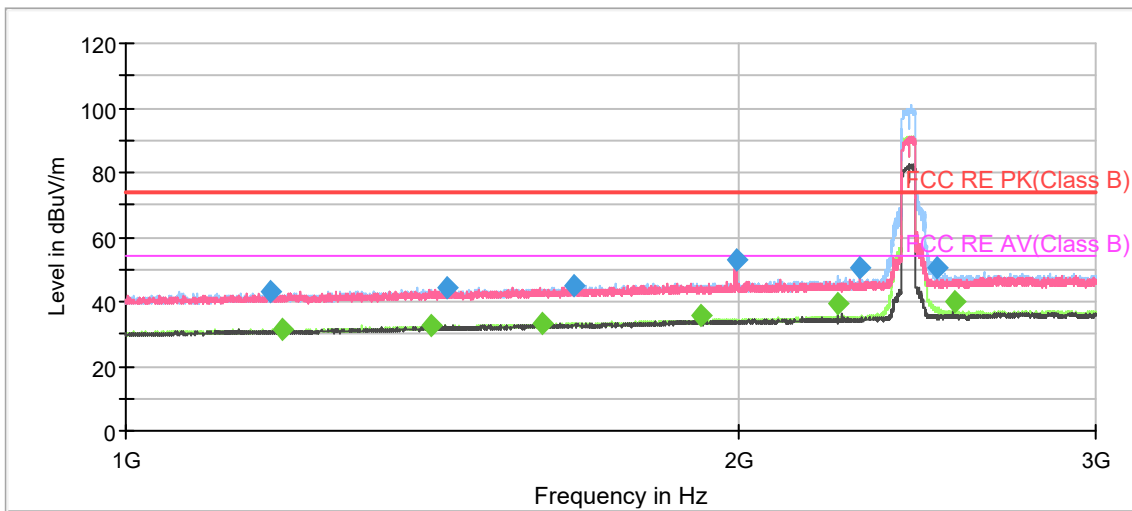

Note: The signal beyond the limit is carrier.  
Radiates Emission from 1GHz to 3GHz

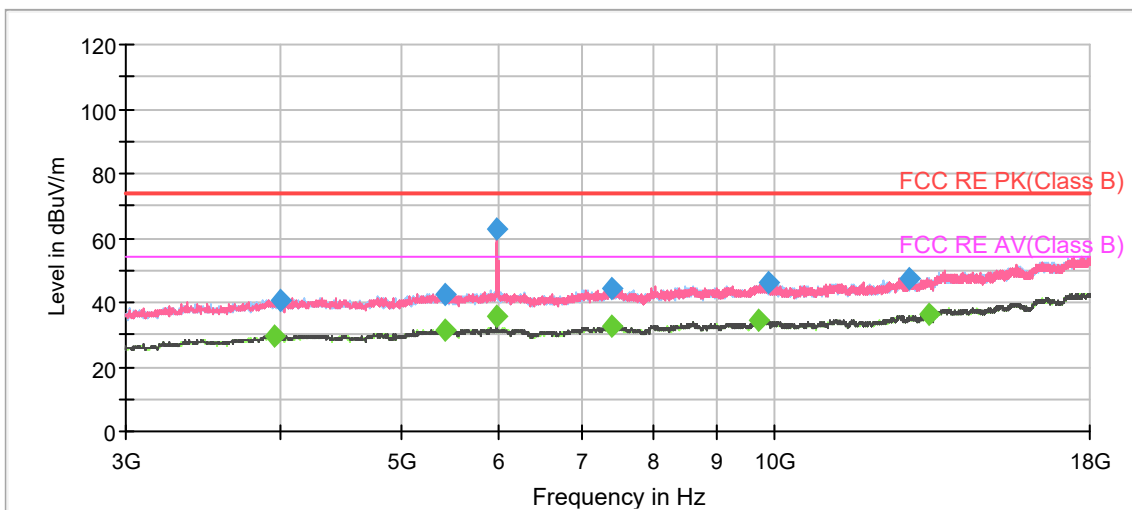

Radiates Emission from 3GHz to 18GHz

Frequency (MHz)	MaxPeak (dB $\mu$ V/m)	Average (dB $\mu$ V/m)	Limit (dB $\mu$ V/m)	Margin (dB)	Meas. Time (ms)	Height (cm)	Pol	Azimuth (deg)	Corr. (dB/m)
1178.000000	43.11	---	74.00	30.89	500.0	100.0	H	162.0	-7.9
1195.250000	---	31.46	54.00	22.54	500.0	200.0	V	208.0	-7.8
1414.250000	---	32.50	54.00	21.50	500.0	100.0	H	76.0	-6.4
1438.250000	44.54	---	74.00	29.46	500.0	200.0	H	71.0	-6.2
1601.500000	---	33.26	54.00	20.74	500.0	200.0	H	108.0	-5.5
1660.000000	44.90	---	74.00	29.10	500.0	100.0	H	130.0	-5.1
1920.000000	---	35.39	54.00	18.61	500.0	100.0	H	58.0	-3.9
1997.500000	52.95	---	74.00	21.05	500.0	200.0	V	135.0	-3.4
2240.000000	---	39.29	54.00	14.71	500.0	100.0	H	333.0	-2.4
2295.750000	50.69	---	74.00	23.31	500.0	200.0	V	268.0	-2.2
2504.000000	50.40	---	74.00	23.60	500.0	100.0	H	314.0	-1.1
2560.000000	---	40.08	54.00	13.92	500.0	200.0	H	324.0	-0.9

**Remark: 1. Correction Factor = Antenna factor + Insertion loss (cable loss + amplifier gain)**

**2. Margin = Limit -MAX Peak/ Average**

802.11n (HT40) CH5

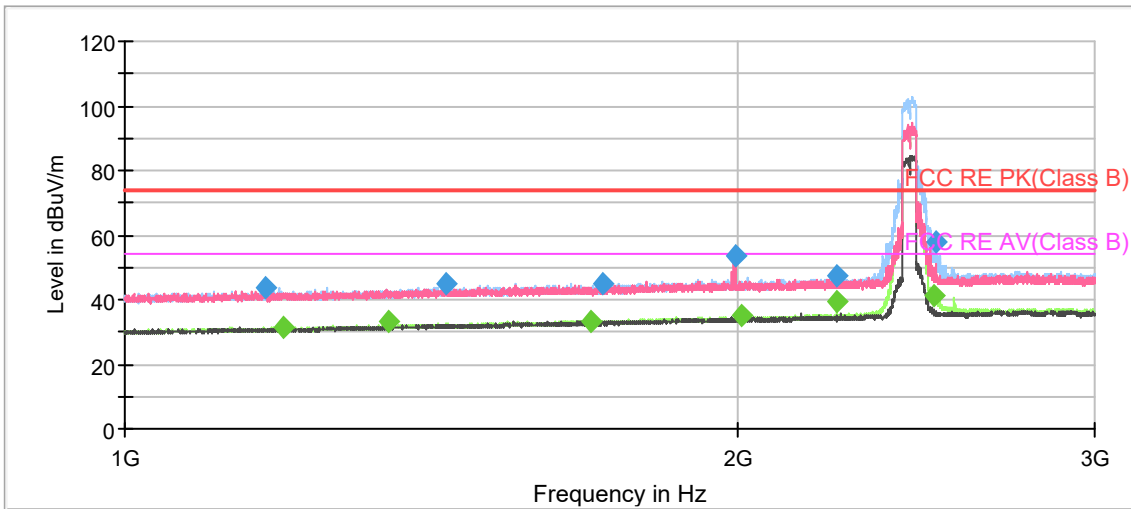

Note: The signal beyond the limit is carrier.  
Radiates Emission from 1GHz to 3GHz

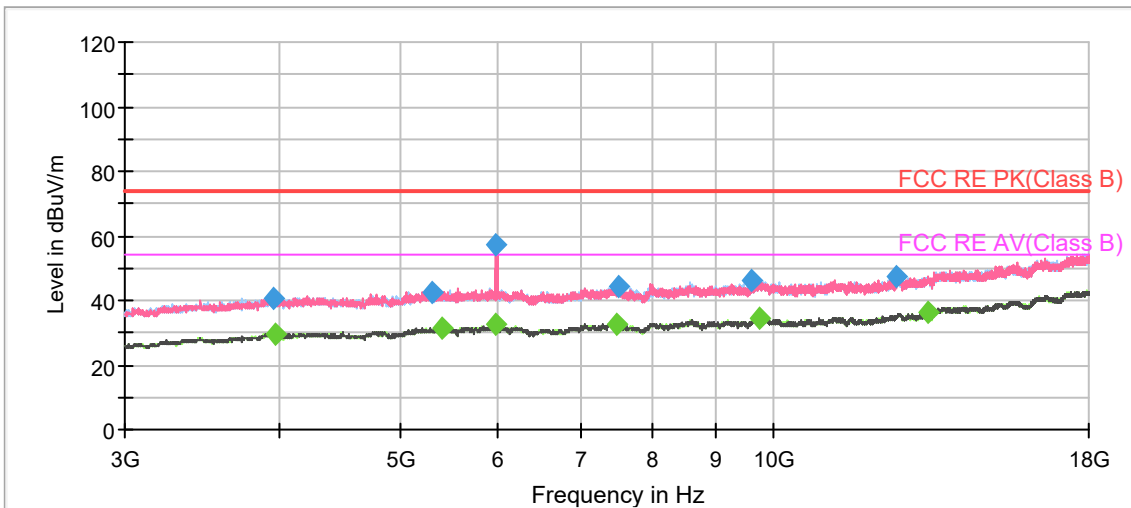

Radiates Emission from 3GHz to 18GHz

Frequency (MHz)	MaxPeak (dB $\mu$ V/m)	Average (dB $\mu$ V/m)	Limit (dB $\mu$ V/m)	Margin (dB)	Meas. Time (ms)	Height (cm)	Pol	Azimuth (deg)	Corr. (dB/m)
1173.500000	43.73	---	74.00	30.27	500.0	100.0	V	20.0	-7.9
1197.250000	---	31.36	54.00	22.64	500.0	100.0	H	278.0	-7.7
1349.750000	---	33.15	54.00	20.85	500.0	200.0	V	167.0	-6.8
1439.750000	44.72	---	74.00	29.28	500.0	200.0	H	74.0	-6.2
1694.250000	---	33.49	54.00	20.51	500.0	200.0	H	205.0	-5.0
1717.500000	45.05	---	74.00	28.95	500.0	100.0	H	260.0	-4.9
1996.500000	53.30	---	74.00	20.70	500.0	200.0	V	131.0	-3.5
2011.500000	---	35.09	54.00	18.91	500.0	100.0	H	272.0	-3.4
2240.000000	---	39.63	54.00	14.37	500.0	200.0	H	0.0	-2.4
2240.500000	47.08	---	74.00	26.92	500.0	100.0	H	355.0	-2.4
2499.250000	---	41.52	54.00	12.48	500.0	100.0	H	319.0	-1.2
2508.500000	57.81	---	74.00	16.19	500.0	200.0	H	323.0	-1.1

**Remark: 1. Correction Factor = Antenna factor + Insertion loss (cable loss + amplifier gain)**

**2. Margin = Limit –MAX Peak/ Average**

802.11n (HT40) CH6

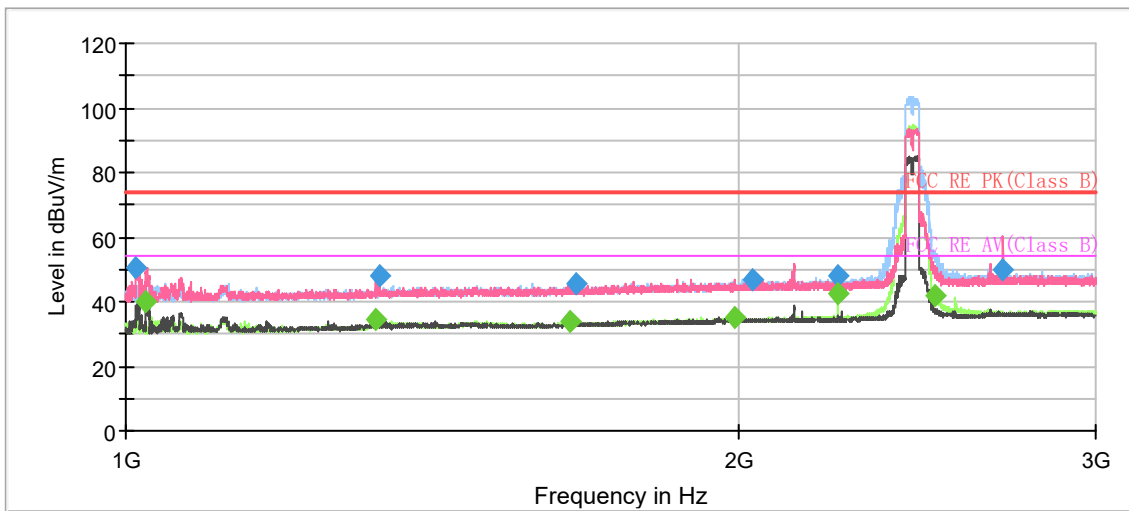

Note: The signal beyond the limit is carrier.  
Radiates Emission from 1GHz to 3GHz

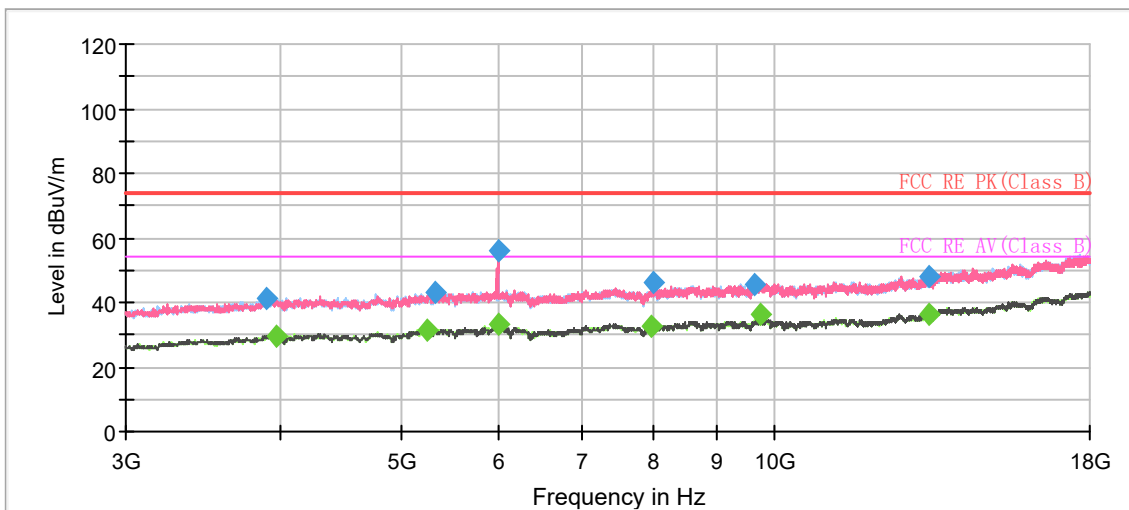

Radiates Emission from 3GHz to 18GHz

Frequency (MHz)	MaxPeak (dB $\mu$ V/m)	Average (dB $\mu$ V/m)	Limit (dB $\mu$ V/m)	Margin (dB)	Meas. Time (ms)	Height (cm)	Pol	Azimuth (deg)	Corr. (dB/m)
1012.250000	50.45	---	74.00	23.55	500.0	200.0	V	215.0	-9.0
1023.500000	---	40.18	54.00	13.82	500.0	200.0	V	215.0	-8.9
1327.750000	---	34.52	54.00	19.48	500.0	200.0	V	248.0	-7.0
1332.000000	47.77	---	74.00	26.23	500.0	100.0	V	159.0	-6.9
1654.750000	---	33.85	54.00	20.15	500.0	200.0	V	59.0	-5.1
1665.000000	45.61	---	74.00	28.39	500.0	200.0	H	199.0	-5.1
1994.000000	---	35.22	54.00	18.78	500.0	100.0	V	62.0	-3.5
2035.250000	46.77	---	74.00	27.23	500.0	200.0	H	253.0	-3.3
2240.000000	48.09	---	74.00	25.91	500.0	200.0	H	87.0	-2.4
2240.000000	---	42.69	54.00	11.31	500.0	200.0	H	87.0	-2.4
2498.750000	---	42.08	54.00	11.92	500.0	100.0	H	89.0	-1.2
2702.250000	50.09	---	74.00	23.91	500.0	200.0	V	358.0	-0.1

**Remark: 1. Correction Factor = Antenna factor + Insertion loss (cable loss + amplifier gain)**

**2. Margin = Limit –MAX Peak/ Average**

802.11n (HT40) CH7

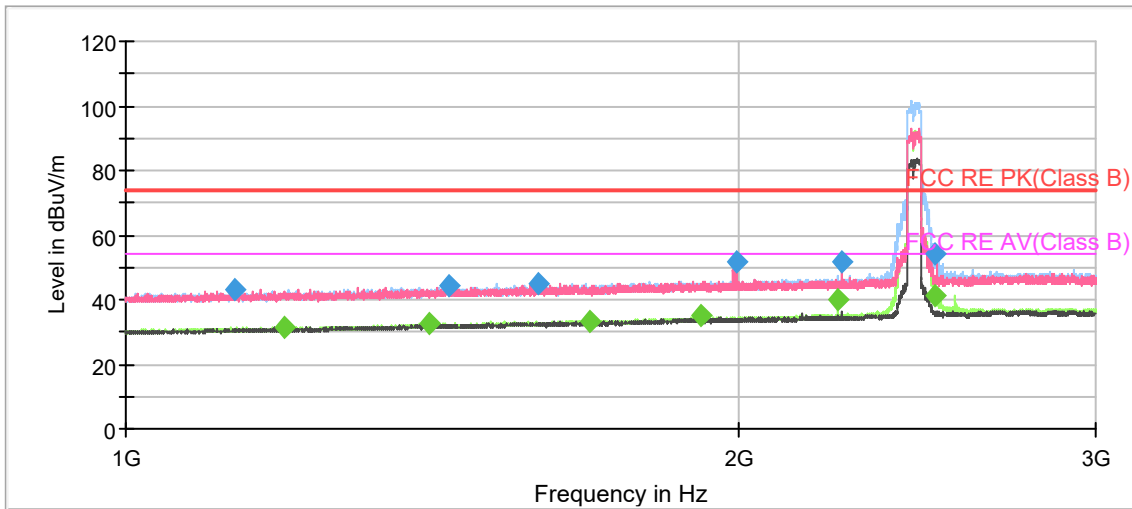

Note: The signal beyond the limit is carrier.  
Radiates Emission from 1GHz to 3GHz

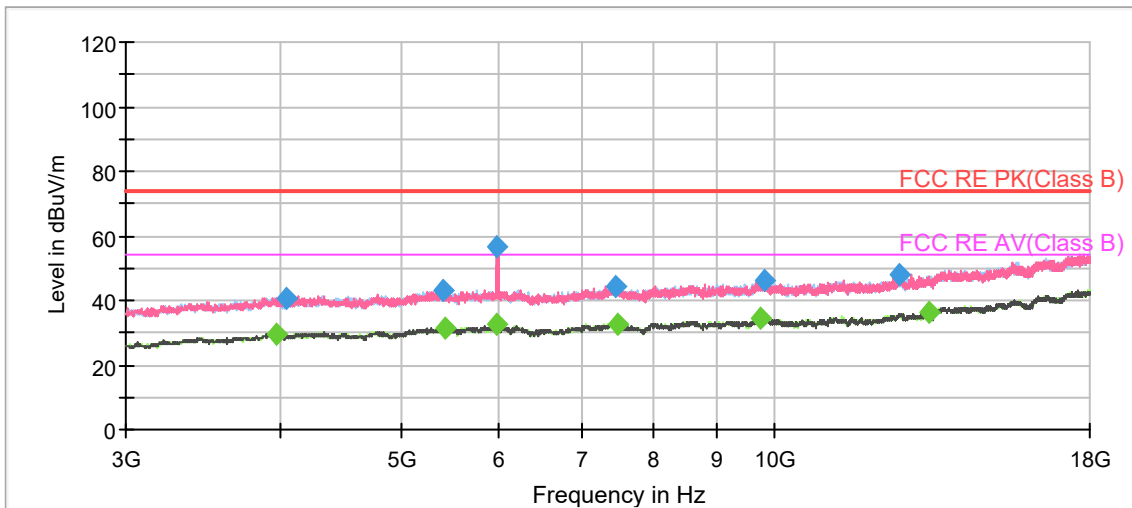

Radiates Emission from 3GHz to 18GHz

Frequency (MHz)	MaxPeak (dB $\mu$ V/m)	Average (dB $\mu$ V/m)	Limit (dB $\mu$ V/m)	Margin (dB)	Meas. Time (ms)	Height (cm)	Pol	Azimuth (deg)	Corr. (dB/m)
1132.500000	43.25	---	74.00	30.75	500.0	100.0	V	345.0	-8.2
1196.750000	---	31.52	54.00	22.48	500.0	200.0	H	164.0	-7.7
1409.250000	---	32.59	54.00	21.41	500.0	200.0	H	186.0	-6.4
1441.750000	44.48	---	74.00	29.52	500.0	100.0	H	177.0	-6.2
1596.250000	45.19	---	74.00	28.81	500.0	200.0	V	354.0	-5.5
1693.500000	---	33.44	54.00	20.56	500.0	100.0	H	268.0	-5.0
1920.250000	---	34.92	54.00	19.08	500.0	100.0	H	288.0	-3.9
1999.500000	51.89	---	74.00	22.11	500.0	200.0	V	133.0	-3.4
2240.000000	---	40.29	54.00	13.71	500.0	200.0	H	354.0	-2.4
2249.500000	51.75	---	74.00	22.25	500.0	100.0	V	45.0	-2.4
2500.500000	54.46	---	74.00	19.54	500.0	100.0	H	7.0	-1.2
2501.250000	---	41.04	54.00	12.96	500.0	200.0	H	0.0	-1.2

**Remark: 1. Correction Factor = Antenna factor + Insertion loss (cable loss + amplifier gain)**

**2. Margin = Limit –MAX Peak/ Average**



802.11n (HT40) CH8

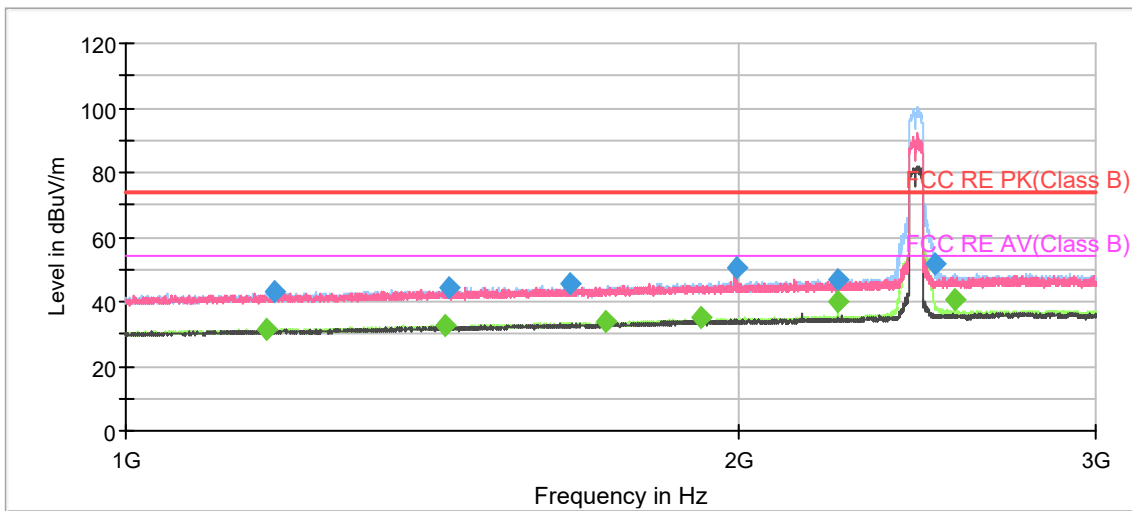

Note: The signal beyond the limit is carrier.  
Radiates Emission from 1GHz to 3GHz

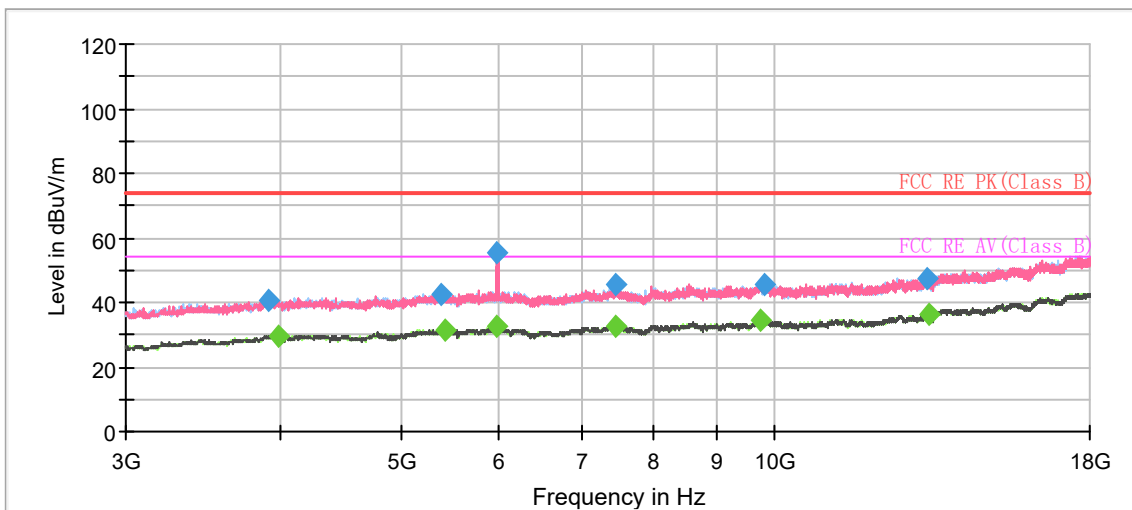

Radiates Emission from 3GHz to 18GHz

Frequency (MHz)	MaxPeak (dB $\mu$ V/m)	Average (dB $\mu$ V/m)	Limit (dB $\mu$ V/m)	Margin (dB)	Meas. Time (ms)	Height (cm)	Pol	Azimuth (deg)	Corr. (dB/m)
1173.750000	---	31.23	54.00	22.77	500.0	100.0	V	38.0	-7.9
1184.500000	43.08	---	74.00	30.92	500.0	100.0	H	213.0	-7.8
1435.000000	---	32.51	54.00	21.49	500.0	100.0	H	249.0	-6.3
1441.250000	44.36	---	74.00	29.64	500.0	200.0	H	86.0	-6.2
1653.250000	45.45	---	74.00	28.55	500.0	200.0	H	313.0	-5.2
1724.250000	---	33.63	54.00	20.37	500.0	100.0	H	113.0	-4.8
1920.250000	---	35.18	54.00	18.82	500.0	100.0	H	352.0	-3.9
1996.750000	50.27	---	74.00	23.73	500.0	200.0	V	42.0	-3.5
2240.000000	---	39.91	54.00	14.09	500.0	100.0	H	352.0	-2.4
2240.500000	46.82	---	74.00	27.18	500.0	200.0	H	320.0	-2.4
2498.250000	51.49	---	74.00	22.51	500.0	200.0	H	6.0	-1.2
2560.000000	---	40.34	54.00	13.66	500.0	200.0	H	329.0	-0.9

**Remark: 1. Correction Factor = Antenna factor + Insertion loss (cable loss + amplifier gain)**

**2. Margin = Limit - MAX Peak/ Average**

802.11n (HT40) CH9

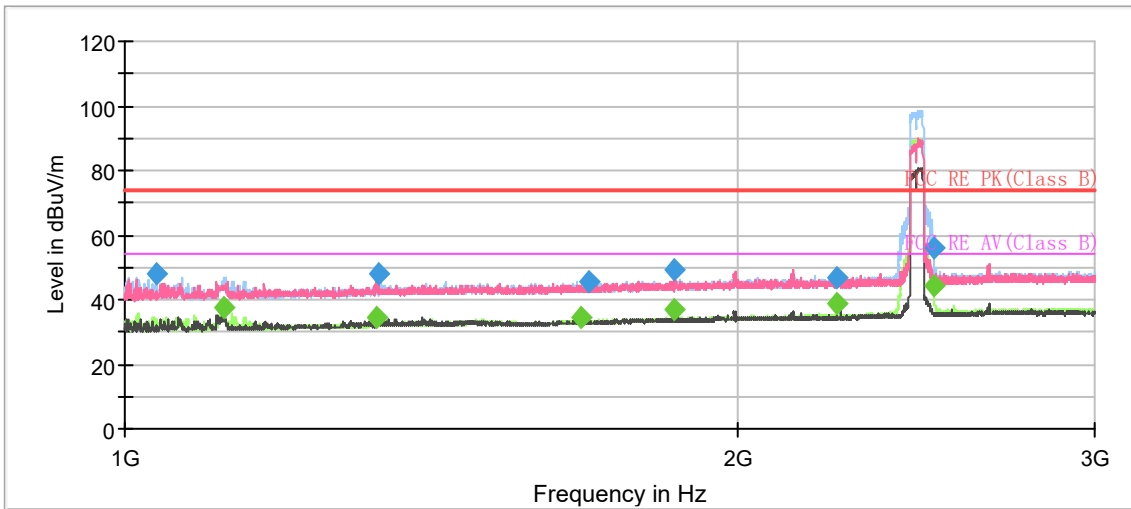

Note: The signal beyond the limit is carrier.  
Radiates Emission from 1GHz to 3GHz

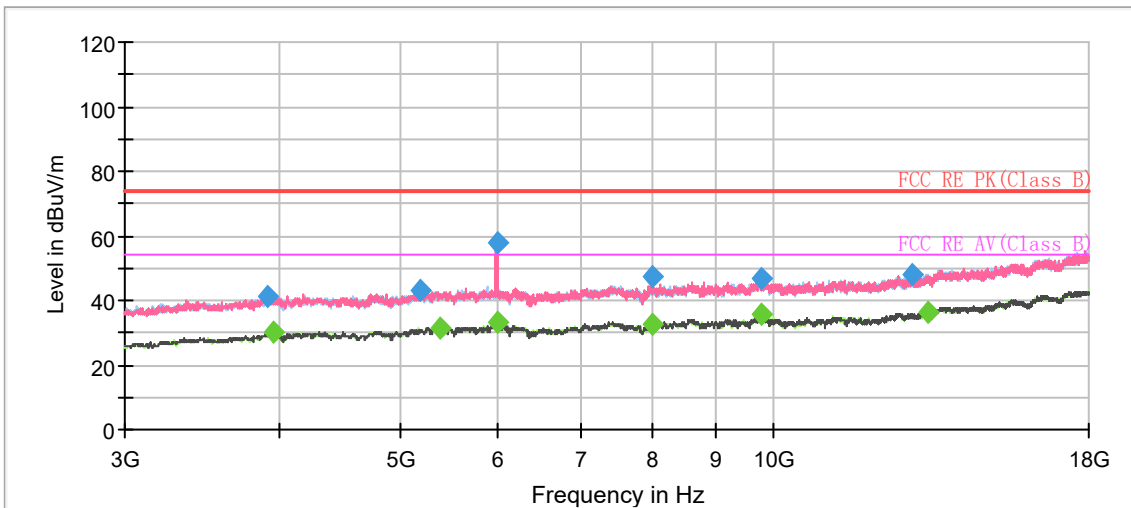

Radiates Emission from 3GHz to 18GHz

Frequency (MHz)	MaxPeak (dB $\mu$ V/m)	Average (dB $\mu$ V/m)	Limit (dB $\mu$ V/m)	Margin (dB)	Meas. Time (ms)	Height (cm)	Pol	Azimuth (deg)	Corr. (dB/m)
1036.000000	48.01	---	74.00	25.99	500.0	100.0	H	240.0	-8.8
1118.250000	---	37.25	54.00	16.75	500.0	200.0	H	225.0	-8.3
1329.250000	---	34.25	54.00	19.75	500.0	200.0	V	235.0	-6.9
1331.750000	48.31	---	74.00	25.69	500.0	100.0	H	226.0	-6.9
1676.250000	---	34.42	54.00	19.58	500.0	200.0	V	188.0	-5.0
1692.000000	45.40	---	74.00	28.60	500.0	100.0	V	246.0	-5.0
1865.000000	49.49	---	74.00	24.51	500.0	100.0	V	49.0	-4.1
1865.000000	---	36.71	54.00	17.29	500.0	100.0	V	49.0	-4.1
2239.750000	46.89	---	74.00	27.11	500.0	200.0	H	95.0	-2.4
2239.750000	---	38.83	54.00	15.17	500.0	100.0	H	79.0	-2.4
2498.500000	---	44.07	54.00	9.93	500.0	200.0	H	82.0	-1.2
2498.500000	55.84	---	74.00	18.16	500.0	200.0	H	82.0	-1.2

**Remark: 1. Correction Factor = Antenna factor + Insertion loss (cable loss + amplifier gain)**

**2. Margin = Limit –MAX Peak/ Average**

During the test, the Radiates Emission from 18GHz to 26.5GHz was performed in all modes with all channels, 802.11g, Channel 9 are selected as the worst condition. The test data of the worst-case condition was recorded in this report.

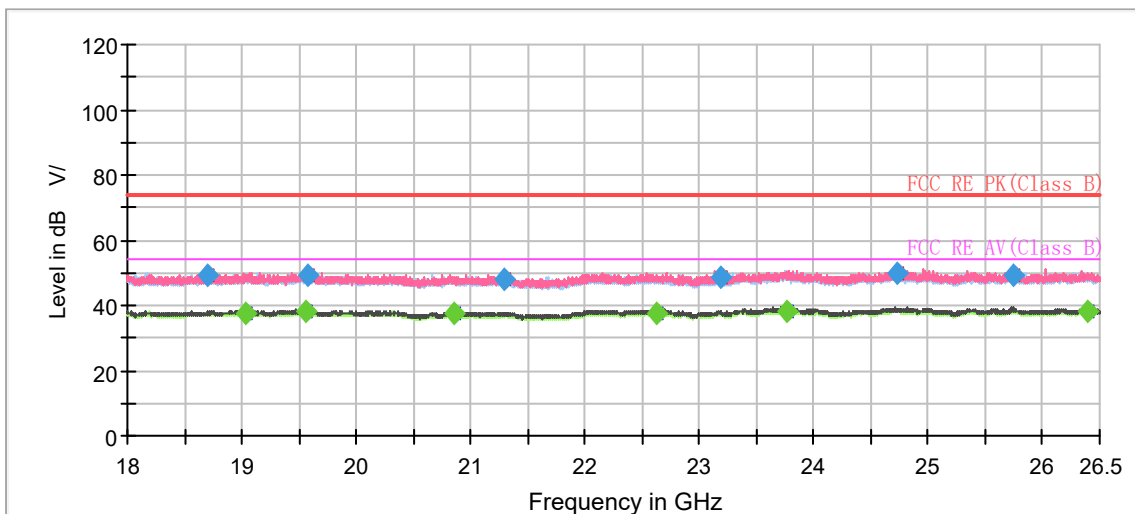

Radiates Emission from 18GHz to 26.5GHz

Frequency (MHz)	MaxPeak (dB $\mu$ V/m)	Average (dB $\mu$ V/m)	Limit (dB $\mu$ V/m)	Margin (dB)	Meas. Time (ms)	Height (cm)	Pol	Azimuth (deg)	Corr. (dB/m)
18694.862486	49.33	---	74.00	24.67	500.0	100.0	H	30.0	-5.6
19029.911062	---	37.77	54.00	16.23	500.0	100.0	V	199.0	-5.6
19567.289433	---	37.87	54.00	16.13	500.0	100.0	V	114.0	-5.3
19575.990401	49.04	---	74.00	24.96	500.0	100.0	V	356.0	-5.3
20855.647481	---	37.24	54.00	16.76	500.0	100.0	V	109.0	-5.1
21293.525943	47.99	---	74.00	26.01	500.0	100.0	V	218.0	-5.2
22621.522762	---	37.76	54.00	16.24	500.0	100.0	V	341.0	-4.0
23181.387279	48.66	---	74.00	25.34	500.0	100.0	V	283.0	-3.7
23761.588942	---	38.41	54.00	15.59	500.0	100.0	V	269.0	-2.4
24722.210307	49.68	---	74.00	24.32	500.0	100.0	V	30.0	-2.2
25742.567019	48.92	---	74.00	25.08	500.0	100.0	V	199.0	-2.6
26388.778012	---	38.16	54.00	15.84	500.0	100.0	V	336.0	-2.3

Remark: 1. Correction Factor = Antenna factor + Insertion loss (cable loss + amplifier gain)

2. Margin = Limit - MAX Peak/ Average

**Bluetooth LE**

During the test, the Radiates Emission from 30MHz to 1GHz was performed in all modes with all channels, Bluetooth LE-Channel 39 are selected as the worst condition. The test data of the worst-case condition was recorded in this report.

A symbol ( $\text{dB } \mu\text{V}/\text{m}$ ) in the test plot below means ( $\text{dB}\mu\text{V}/\text{m}$ )

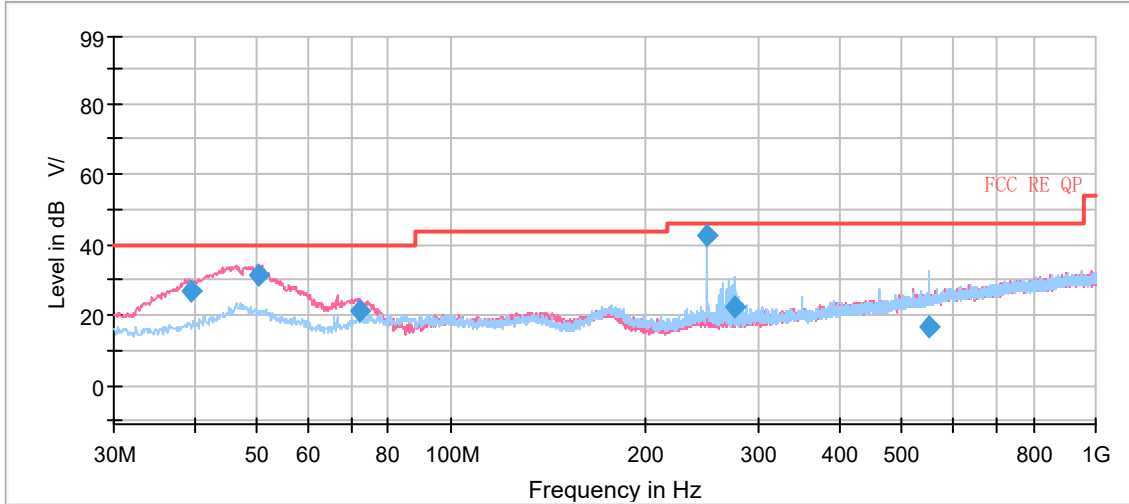

Radiates Emission from 30MHz to 1GHz

Frequency (MHz)	Quasi-Peak ( $\text{dB}\mu\text{V}/\text{m}$ )	Limit ( $\text{dB}\mu\text{V}/\text{m}$ )	Margin (dB)	Height (cm)	Polarization	Azimuth (deg)	Correct Factor (dB)
39.411075	26.59	40.00	13.41	100.0	V	11.0	19.3
50.316863	31.18	40.00	8.82	100.0	V	168.0	20.6
72.434025	21.39	40.00	18.61	175.0	V	217.0	15.4
249.978000	42.60	46.00	3.40	100.0	H	284.0	19.9
275.071250	22.32	46.00	23.68	100.0	H	62.0	19.8
549.973750	16.88	46.00	29.12	175.0	H	129.0	25.6

Remark: 1. Correction Factor = Antenna factor + Insertion loss (cable loss + amplifier gain)

2. Margin = Limit – Quasi-Peak

Bluetooth LE-Channel 0

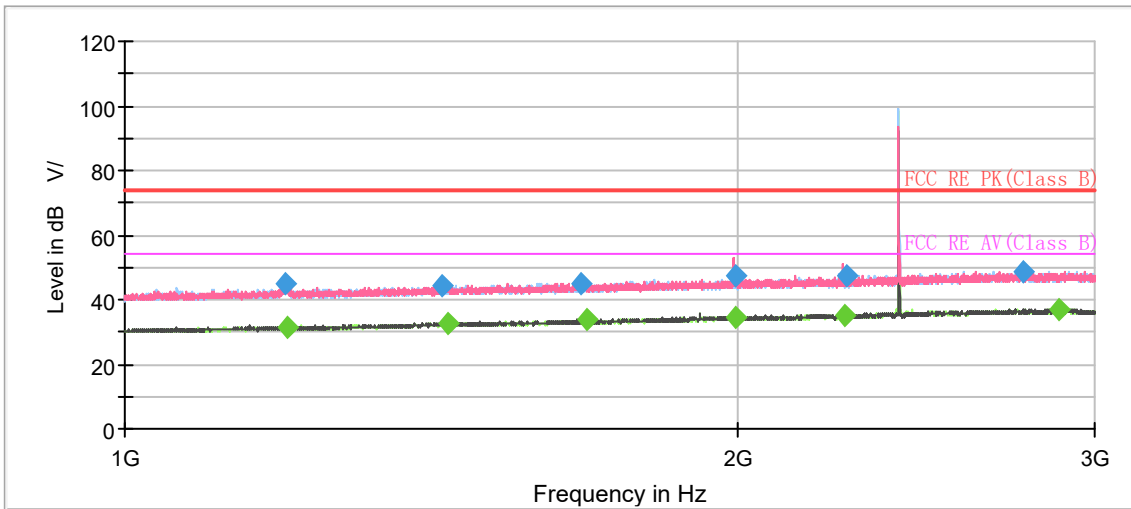

Note: The signal beyond the limit is carrier.  
Radiates Emission from 1GHz to 3GHz

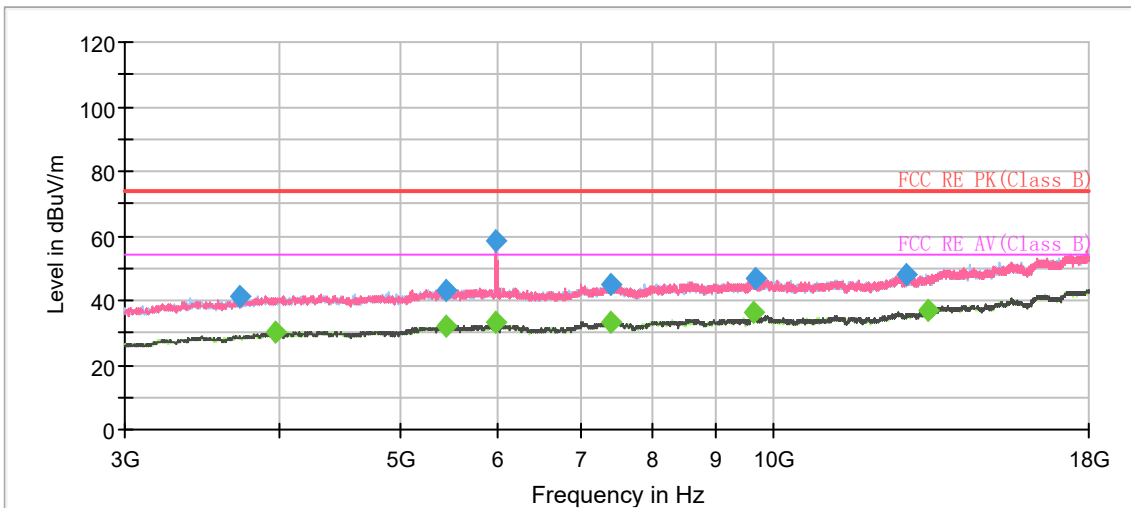

Radiates Emission from 3GHz to 18GHz

Frequency (MHz)	MaxPeak (dB $\mu$ V/m)	Average (dB $\mu$ V/m)	Limit (dB $\mu$ V/m)	Margin (dB)	Meas. Time (ms)	Height (cm)	Pol	Azimuth (deg)	Corr. (dB/m)
1200.250000	45.18	---	74.00	28.82	500.0	100.0	H	158.0	-7.7
1201.250000	---	31.66	54.00	22.34	500.0	100.0	H	149.0	-7.7
1432.000000	44.53	---	74.00	29.47	500.0	200.0	V	122.0	-6.3
1441.250000	---	32.69	54.00	21.31	500.0	200.0	V	177.0	-6.2
1677.750000	45.23	---	74.00	28.77	500.0	100.0	V	103.0	-5.0
1686.500000	---	33.64	54.00	20.36	500.0	100.0	V	122.0	-5.0
1995.750000	---	34.48	54.00	19.52	500.0	100.0	V	182.0	-3.5
1996.000000	47.36	---	74.00	26.64	500.0	100.0	V	296.0	-3.5
2262.500000	---	35.08	54.00	18.92	500.0	100.0	V	347.0	-2.3
2265.000000	47.08	---	74.00	26.92	500.0	100.0	H	222.0	-2.3
2766.000000	48.60	---	74.00	25.40	500.0	100.0	V	85.0	-0.1
2880.250000	---	37.18	54.00	16.82	500.0	200.0	V	137.0	0.2

**Remark: 1. Correction Factor = Antenna factor + Insertion loss (cable loss + amplifier gain)**

**2. Margin = Limit - MAX Peak/ Average**



Bluetooth LE-Channel 19

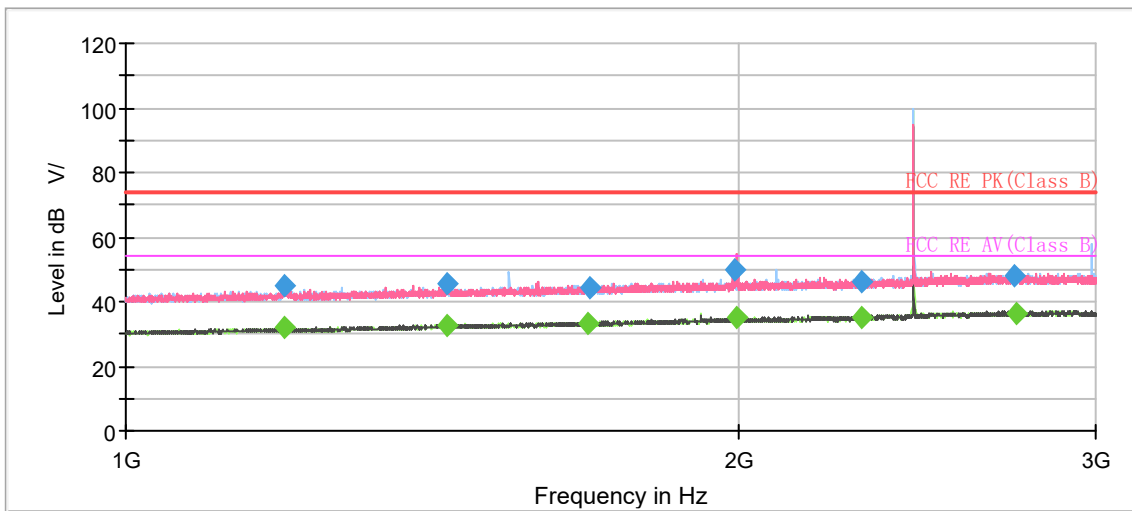

Note: The signal beyond the limit is carrier.  
Radiates Emission from 1GHz to 3GHz

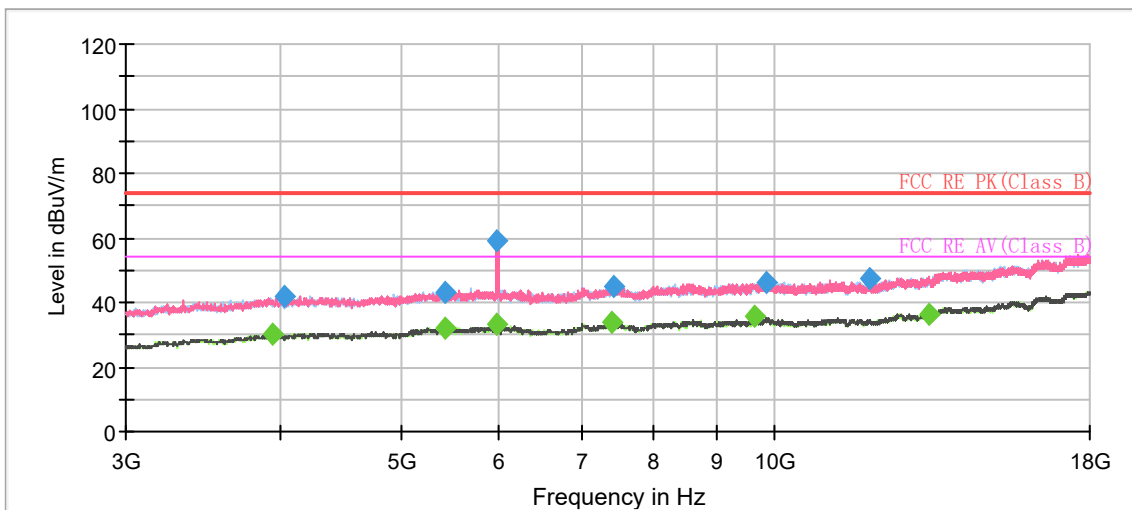

Radiates Emission from 3GHz to 18GHz

Frequency (MHz)	MaxPeak (dB $\mu$ V/m)	Average (dB $\mu$ V/m)	Limit (dB $\mu$ V/m)	Margin (dB)	Meas. Time (ms)	Height (cm)	Pol	Azimuth (deg)	Corr. (dB/m)
1197.500000	45.10	---	74.00	28.90	500.0	200.0	V	111.0	-7.7
1197.500000	---	32.11	54.00	21.89	500.0	200.0	V	111.0	-7.7
1437.500000	45.57	---	74.00	28.43	500.0	100.0	H	28.0	-6.2
1438.500000	---	32.72	54.00	21.28	500.0	100.0	H	190.0	-6.2
1686.250000	---	33.53	54.00	20.47	500.0	200.0	V	33.0	-5.0
1690.250000	44.61	---	74.00	29.39	500.0	200.0	H	299.0	-5.0
1993.250000	49.73	---	74.00	24.27	500.0	100.0	V	167.0	-3.5
1996.250000	---	35.21	54.00	18.79	500.0	200.0	V	197.0	-3.5
2299.250000	---	34.84	54.00	19.16	500.0	100.0	H	124.0	-2.2
2301.500000	46.26	---	74.00	27.74	500.0	100.0	H	171.0	-2.2
2735.250000	47.89	---	74.00	26.11	500.0	200.0	H	326.0	-0.1
2739.500000	---	36.42	54.00	17.58	500.0	100.0	H	231.0	-0.1

**Remark: 1. Correction Factor = Antenna factor + Insertion loss (cable loss + amplifier gain)**

**2. Margin = Limit –MAX Peak/ Average**

Bluetooth LE-Channel 39

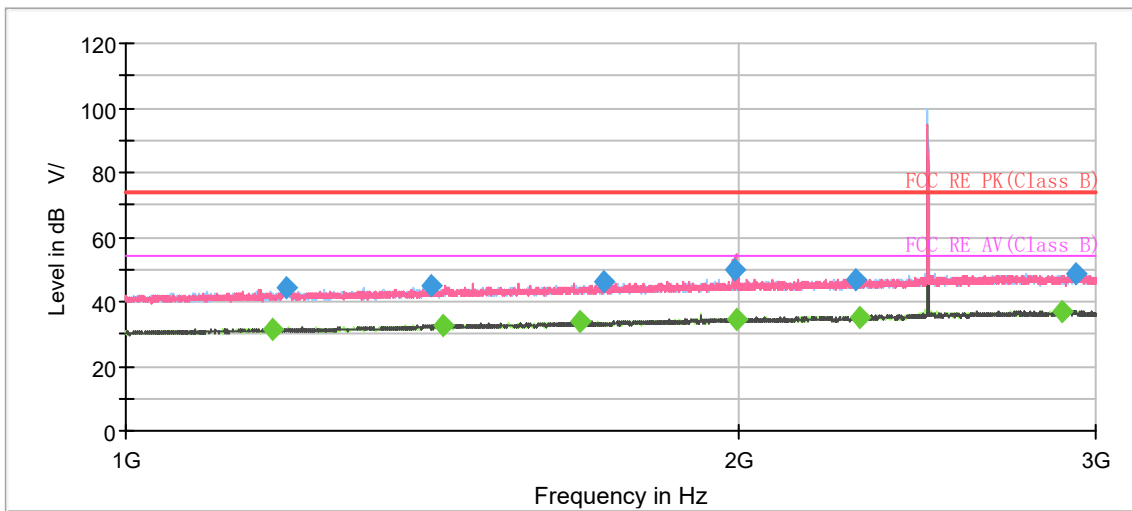

Note: The signal beyond the limit is carrier.  
Radiates Emission from 1GHz to 3GHz

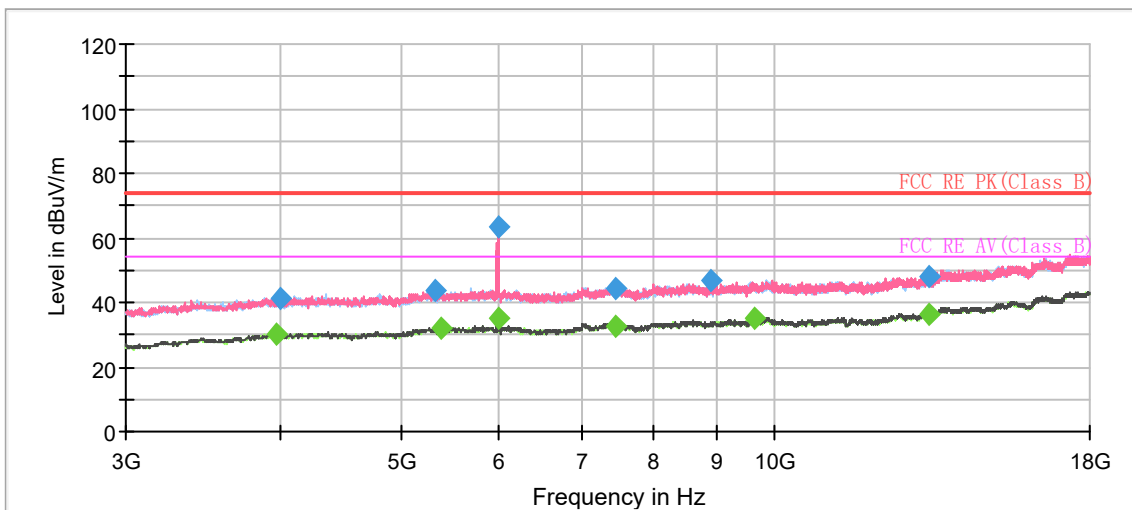

Radiates Emission from 3GHz to 18GHz

Frequency (MHz)	MaxPeak (dB $\mu$ V/m)	Average (dB $\mu$ V/m)	Limit (dB $\mu$ V/m)	Margin (dB)	Meas. Time (ms)	Height (cm)	Pol	Azimuth (deg)	Corr. (dB/m)
1181.000000	---	31.57	54.00	22.43	500.0	200.0	H	214.0	-7.9
1200.000000	44.61	---	74.00	29.39	500.0	200.0	H	191.0	-7.7
1414.500000	44.90	---	74.00	29.10	500.0	100.0	H	34.0	-6.4
1431.750000	---	32.83	54.00	21.17	500.0	100.0	V	232.0	-6.3
1672.750000	---	33.75	54.00	20.25	500.0	100.0	V	89.0	-5.0
1720.250000	46.16	---	74.00	27.84	500.0	100.0	V	316.0	-4.9
1993.250000	49.87	---	74.00	24.13	500.0	200.0	V	144.0	-3.5
1995.500000	---	34.72	54.00	19.28	500.0	200.0	V	135.0	-3.5
2284.250000	46.55	---	74.00	27.45	500.0	100.0	V	153.0	-2.3
2295.500000	---	35.25	54.00	18.75	500.0	100.0	H	53.0	-2.2
2887.250000	---	36.98	54.00	17.02	500.0	100.0	V	357.0	0.2
2936.000000	48.69	---	74.00	25.31	500.0	200.0	H	131.0	0.3
5998.125000	63.32	---	74.00	10.68	500.0	100.0	V	249.0	-2.0

**Remark: 1. Correction Factor = Antenna factor + Insertion loss (cable loss + amplifier gain)**

**2. Margin = Limit -MAX Peak/ Average**

During the test, the Radiates Emission from 18GHz to 26.5GHz was performed in all modes with all channels, Bluetooth LE-Channel 39 are selected as the worst condition. The test data of the worst-case condition was recorded in this report.

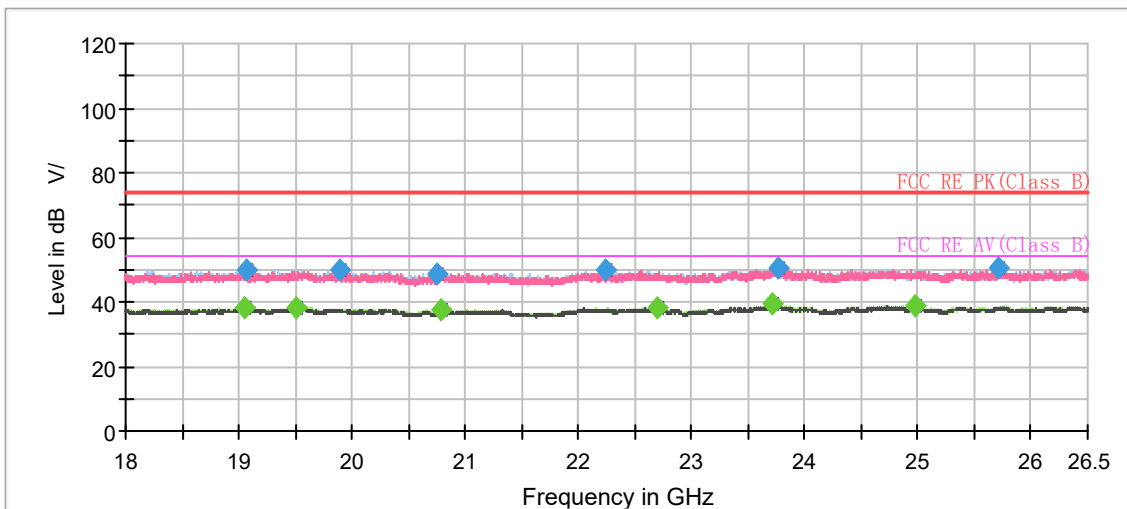

Radiates Emission from 18GHz to 26.5GHz

Frequency (MHz)	MaxPeak (dB $\mu$ V/m)	Average (dB $\mu$ V/m)	Limit (dB $\mu$ V/m)	Margin (dB)	Meas. Time (ms)	Height (cm)	Pol	Azimuth (deg)	Corr. (dB/m)
19046.562500	---	38.22	54.00	15.78	500.0	100.0	H	353.0	-5.6
19073.125000	49.77	---	74.00	24.23	500.0	100.0	V	140.0	-5.7
19499.187500	---	38.30	54.00	15.70	500.0	100.0	V	66.0	-5.3
19894.437500	50.10	---	74.00	23.90	500.0	100.0	H	348.0	-5.2
20758.250000	48.91	---	74.00	25.09	500.0	200.0	V	142.0	-5.1
20789.062500	---	37.63	54.00	16.37	500.0	100.0	H	245.0	-5.1
22237.250000	49.84	---	74.00	24.16	500.0	100.0	V	75.0	-4.1
22703.687500	---	38.19	54.00	15.81	500.0	100.0	V	43.0	-4.0
23718.375000	---	39.15	54.00	14.85	500.0	100.0	V	5.0	-2.4
23759.812500	50.69	---	74.00	23.31	500.0	200.0	V	282.0	-2.4
24983.812500	---	38.56	54.00	15.44	500.0	100.0	H	264.0	-2.5
25708.437500	50.35	---	74.00	23.65	500.0	100.0	H	353.0	-2.6

### 5.7. Conducted Emission

#### Ambient Condition

Temperature	Relative humidity
20°C ~25°C	45%~50%

#### Methods of Measurement

The EUT is placed on a non-metallic table of 80cm height above the horizontal metal reference ground plane. During the test, the EUT was operating in its typical mode. The test method is according to ANSI C63.10. Connect the AC power line of the EUT to the L.I.S.N. Use EMI receiver to detect the average and Quasi-peak value. RBW is set to 9 kHz, VBW is set to 30kHz. The measurement result should include both L line and N line. The test is in transmitting mode.

#### Test Setup

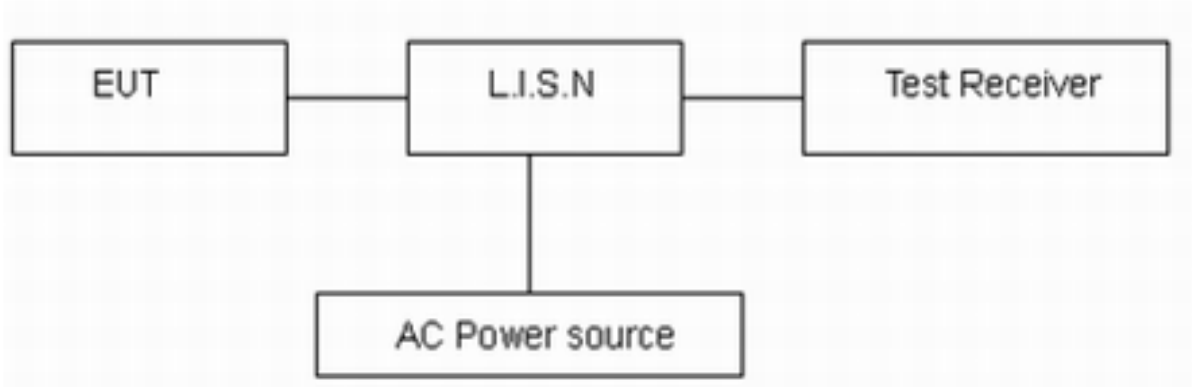

Note: AC Power source is used to change the voltage 110V/60Hz.

#### Limits

Frequency (MHz)	Conducted Limits(dBμV)	
	Quasi-peak	Average
0.15 - 0.5	66 to 56 *	56 to 46 *
0.5 - 5	56	46
5 - 30	60	50

\*: Decreases with the logarithm of the frequency.

#### Measurement Uncertainty

The assessed measurement uncertainty to ensure 95% confidence level for the normal distribution is with the coverage factor  $k = 1.96$ ,  $U = 2.69$  dB.

**Test Results:**

Following plots, Blue trace uses the peak detection and Green trace uses the average detection.

**Wi-Fi 2.4G**

During the test, the Conducted Emission was performed in all modes with all channels, 802.11g, Channel 9 are selected as the worst condition. The test data of the worst-case condition was recorded in this report.

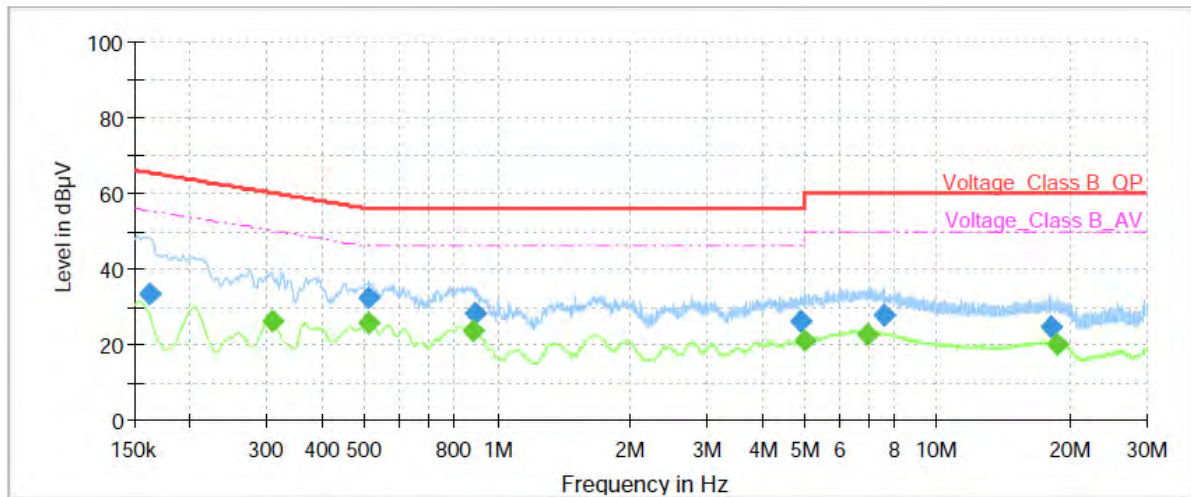

Frequency (MHz)	QuasiPeak (dBµV)	Average (dBµV)	Limit (dBµV)	Margin (dB)	Meas. Time (ms)	Bandwidth (kHz)	Line	Filter	Corr. (dB)
0.16	33.31	---	65.40	32.09	1000.0	9.000	L1	ON	21.0
0.31	---	26.30	50.04	23.74	1000.0	9.000	L1	ON	21.0
0.51	---	25.59	46.00	20.41	1000.0	9.000	L1	ON	20.9
0.51	32.38	---	56.00	23.62	1000.0	9.000	L1	ON	20.9
0.88	---	23.36	46.00	22.64	1000.0	9.000	L1	ON	20.3
0.89	27.97	---	56.00	28.03	1000.0	9.000	L1	ON	20.3
4.90	26.25	---	56.00	29.75	1000.0	9.000	L1	ON	19.5
4.98	---	20.86	46.00	25.14	1000.0	9.000	L1	ON	19.5
6.91	---	22.79	50.00	27.21	1000.0	9.000	L1	ON	19.5
7.58	27.56	---	60.00	32.44	1000.0	9.000	L1	ON	19.5
18.10	24.77	---	60.00	35.23	1000.0	9.000	L1	ON	19.7
18.79	---	19.80	50.00	30.20	1000.0	9.000	L1	ON	19.7

**Remark: Correct factor=cable loss + LISN factor**

L line Conducted Emission from 150 KHz to 30 MHz

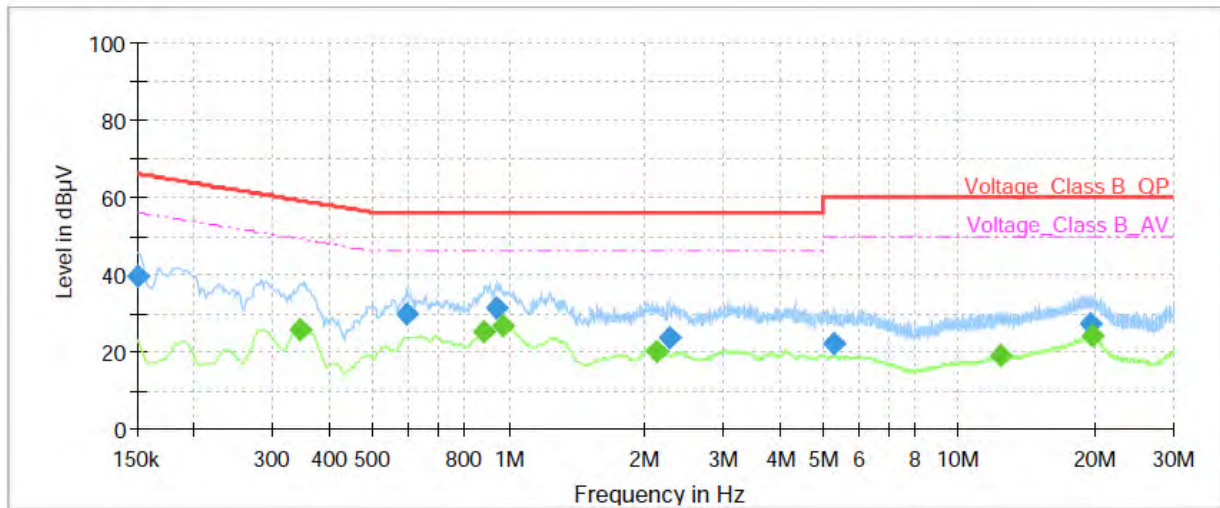

Frequency (MHz)	QuasiPeak (dBµV)	Average (dBµV)	Limit (dBµV)	Margin (dB)	Meas. Time (ms)	Bandwidth (kHz)	Line	Filter	Corr. (dB)
0.15	39.29	---	66.00	26.71	1000.0	9.000	N	ON	21.0
0.35	---	25.49	49.06	23.57	1000.0	9.000	N	ON	21.0
0.59	29.58	---	56.00	26.42	1000.0	9.000	N	ON	20.8
0.88	---	25.27	46.00	20.73	1000.0	9.000	N	ON	20.3
0.94	31.17	---	56.00	24.83	1000.0	9.000	N	ON	20.3
0.98	---	26.74	46.00	19.26	1000.0	9.000	N	ON	20.3
2.12	---	20.24	46.00	25.76	1000.0	9.000	N	ON	19.7
2.27	23.74	---	56.00	32.26	1000.0	9.000	N	ON	19.6
5.28	22.07	---	60.00	37.93	1000.0	9.000	N	ON	19.5
12.34	---	19.10	50.00	30.90	1000.0	9.000	N	ON	19.6
19.50	27.32	---	60.00	32.68	1000.0	9.000	N	ON	19.7
19.80	---	23.99	50.00	26.01	1000.0	9.000	N	ON	19.8

Remark: Correct factor=cable loss + LISN factor

N line Conducted Emission from 150 KHz to 30 MHz



**Bluetooth LE**

During the test, the Conducted Emission was performed in all modes with all channels, Bluetooth LE-Channel 39 are selected as the worst condition. The test data of the worst-case condition was recorded in this report.

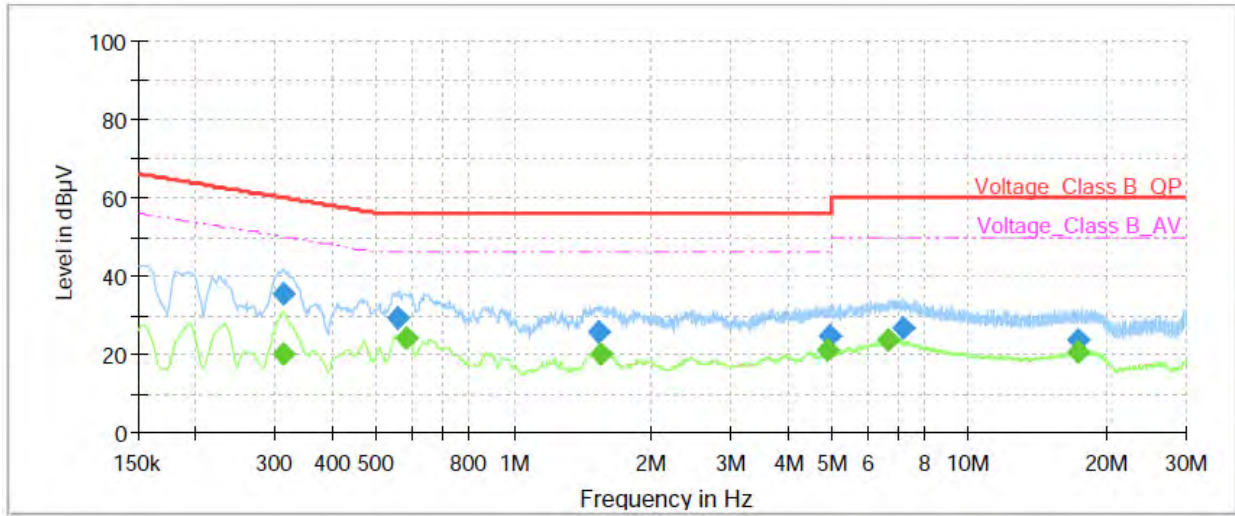

Frequency (MHz)	QuasiPeak (dBµV)	Average (dBµV)	Limit (dBµV)	Margin (dB)	Meas. Time (ms)	Bandwidth (kHz)	Line	Filter	Corr. (dB)
0.31	---	20.10	49.92	29.81	1000.0	9.000	L1	ON	21.0
0.31	35.53	---	59.92	24.39	1000.0	9.000	L1	ON	21.0
0.56	29.13	---	56.00	26.87	1000.0	9.000	L1	ON	20.8
0.58	---	24.20	46.00	21.80	1000.0	9.000	L1	ON	20.8
1.54	25.40	---	56.00	30.60	1000.0	9.000	L1	ON	19.9
1.56	---	19.95	46.00	26.05	1000.0	9.000	L1	ON	19.9
4.88	---	20.95	46.00	25.05	1000.0	9.000	L1	ON	19.5
4.97	24.43	---	56.00	31.57	1000.0	9.000	L1	ON	19.5
6.67	---	23.55	50.00	26.45	1000.0	9.000	L1	ON	19.5
7.15	26.75	---	60.00	33.25	1000.0	9.000	L1	ON	19.5
17.39	---	20.41	50.00	29.59	1000.0	9.000	L1	ON	19.7
17.45	23.58	---	60.00	36.42	1000.0	9.000	L1	ON	19.7

**Remark: Correct factor=cable loss + LISN factor**

L line Conducted Emission from 150 KHz to 30 MHz

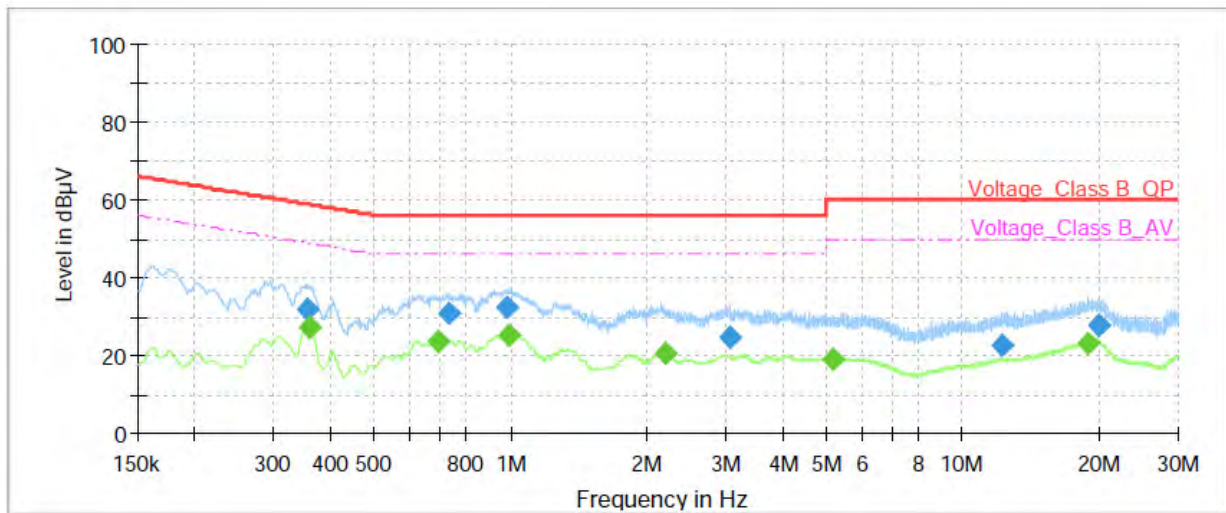

Frequency (MHz)	QuasiPeak (dBµV)	Average (dBµV)	Limit (dBµV)	Margin (dB)	Meas. Time (ms)	Bandwidth (kHz)	Line	Filter	Corr. (dB)
0.36	31.84	---	58.80	26.96	1000.0	9.000	N	ON	21.0
0.36	---	27.30	48.75	21.45	1000.0	9.000	N	ON	21.0
0.69	---	23.48	46.00	22.52	1000.0	9.000	N	ON	20.7
0.73	30.66	---	56.00	25.34	1000.0	9.000	N	ON	20.6
0.98	32.34	---	56.00	23.66	1000.0	9.000	N	ON	20.3
0.99	---	25.23	46.00	20.77	1000.0	9.000	N	ON	20.2
2.19	---	20.63	46.00	25.37	1000.0	9.000	N	ON	19.7
3.05	24.86	---	56.00	31.14	1000.0	9.000	N	ON	19.6
5.18	---	18.75	50.00	31.25	1000.0	9.000	N	ON	19.5
12.20	22.44	---	60.00	37.56	1000.0	9.000	N	ON	19.6
19.06	---	23.03	50.00	26.97	1000.0	9.000	N	ON	19.7
19.95	27.90	---	60.00	32.10	1000.0	9.000	N	ON	19.8

Remark: Correct factor=cable loss + LISN factor

N line Conducted Emission from 150 KHz to 30 MHz

## 6. Main Test Instruments

Name	Manufacturer	Type	Serial Number	Calibration Date	Expiration Date
Spectrum Analyzer	KEYSIGHT	N9020A	MY50510203	2022-12-10	2023-12-09
Power Sensor	R&S	NRP18S	101954	2022-05-14	2023-05-13
Radiated Emission					
EMI Test Receiver	R&S	ESR	102389	2022-05-25	2023-05-24
Signal Analyzer	R&S	FSV40	101186	2022-05-14	2023-05-13
Loop Antenna	SCHWARZBECK	FMZB1519	1519-047	2020-04-02	2024-04-01
TRILOG Broadband Antenna	SCHWARZBECK	VULB 9163	01111	2022-10-25	2025-10-24
Horn Antenna	R&S	HF907	102723	2020-08-11	2023-08-10
Horn Antenna	ETS-Lindgren	3160-09	00102643	2021-10-10	2024-10-09
Software	R&S	EMC32	9.26.01	/	/
Conducted Emission					
Artificial main network	R&S	ENV216	102191	2022-12-13	2024-12-09
EMI Test Receiver	R&S	ESR	101667	2022-05-25	2023-05-24
Software	R&S	EMC32	10.35.10	/	/

\*\*\*\*\*END OF REPORT \*\*\*\*\*

## **ANNEX A: The EUT Appearance**

The EUT Appearance are submitted separately.

## **ANNEX B: Test Setup Photos**

**The Test Setup Photos are submitted separately.**