

CC200A-LB

Hardware Design

Satellite Communication Module Series

Version: 1.0.0

Date: 2023-05-26

Status: Preliminary



At Quectel, our aim is to provide timely and comprehensive services to our customers. If you require any assistance, please contact our headquarters:

Quectel Wireless Solutions Co., Ltd.

Building 5, Shanghai Business Park Phase III (Area B), No.1016 Tianlin Road, Minhang District, Shanghai 200233, China

Tel: +86 21 5108 6236

Email: info@quectel.com

Or our local offices. For more information, please visit:

<http://www.quectel.com/support/sales.htm>.

For technical support, or to report documentation errors, please visit:

<http://www.quectel.com/support/technical.htm>.

Or email us at: support@quectel.com.

Legal Notices

We offer information as a service to you. The provided information is based on your requirements and we make every effort to ensure its quality. You agree that you are responsible for using independent analysis and evaluation in designing intended products, and we provide reference designs for illustrative purposes only. Before using any hardware, software or service guided by this document, please read this notice carefully. Even though we employ commercially reasonable efforts to provide the best possible experience, you hereby acknowledge and agree that this document and related services hereunder are provided to you on an “as available” basis. We may revise or restate this document from time to time at our sole discretion without any prior notice to you.

Use and Disclosure Restrictions

License Agreements

Documents and information provided by us shall be kept confidential, unless specific permission is granted. They shall not be accessed or used for any purpose except as expressly provided herein.

Copyright

Our and third-party products hereunder may contain copyrighted material. Such copyrighted material shall not be copied, reproduced, distributed, merged, published, translated, or modified without prior written consent. We and the third party have exclusive rights over copyrighted material. No license shall be granted or conveyed under any patents, copyrights, trademarks, or service mark rights. To avoid ambiguities, purchasing in any form cannot be deemed as granting a license other than the normal non-exclusive, royalty-free license to use the material. We reserve the right to take legal action for noncompliance with abovementioned requirements, unauthorized use, or other illegal or malicious use of the material.

Trademarks

Except as otherwise set forth herein, nothing in this document shall be construed as conferring any rights to use any trademark, trade name or name, abbreviation, or counterfeit product thereof owned by Quectel or any third party in advertising, publicity, or other aspects.

Third-Party Rights

This document may refer to hardware, software and/or documentation owned by one or more third parties (“third-party materials”). Use of such third-party materials shall be governed by all restrictions and obligations applicable thereto.

We make no warranty or representation, either express or implied, regarding the third-party materials, including but not limited to any implied or statutory, warranties of merchantability or fitness for a particular purpose, quiet enjoyment, system integration, information accuracy, and non-infringement of any third-party intellectual property rights with regard to the licensed technology or use thereof. Nothing herein constitutes a representation or warranty by us to either develop, enhance, modify, distribute, market, sell, offer for sale, or otherwise maintain production of any our products or any other hardware, software, device, tool, information, or product. We moreover disclaim any and all warranties arising from the course of dealing or usage of trade.

Privacy Policy

To implement module functionality, certain device data are uploaded to Quectel’s or third-party’s servers, including carriers, chipset suppliers or customer-designated servers. Quectel, strictly abiding by the relevant laws and regulations, shall retain, use, disclose or otherwise process relevant data for the purpose of performing the service only or as permitted by applicable laws. Before data interaction with third parties, please be informed of their privacy and data security policy.

Disclaimer

- a) We acknowledge no liability for any injury or damage arising from the reliance upon the information.
- b) We shall bear no liability resulting from any inaccuracies or omissions, or from the use of the information contained herein.
- c) While we have made every effort to ensure that the functions and features under development are free from errors, it is possible that they could contain errors, inaccuracies, and omissions. Unless otherwise provided by valid agreement, we make no warranties of any kind, either implied or express, and exclude all liability for any loss or damage suffered in connection with the use of features and functions under development, to the maximum extent permitted by law, regardless of whether such loss or damage may have been foreseeable.
- d) We are not responsible for the accessibility, safety, accuracy, availability, legality, or completeness of information, advertising, commercial offers, products, services, and materials on third-party websites and third-party resources.

Copyright © Quectel Wireless Solutions Co., Ltd. 2023. All rights reserved.

Safety Information

The following safety precautions must be observed during all phases of operation, such as usage, service or repair of any cellular terminal or mobile incorporating the module. Manufacturers of the cellular terminal should notify users and operating personnel of the following safety information by incorporating these guidelines into all manuals of the product. Quectel assumes no liability for customers' failure to comply with these precautions.



Full attention must be paid to driving at all times in order to reduce the risk of an accident. Using a mobile while driving (even with a handsfree kit) causes distraction and can lead to an accident. Please comply with laws and regulations restricting the use of wireless devices while driving.



Switch off the cellular terminal or mobile before boarding an aircraft. The operation of wireless appliances in an aircraft is forbidden to prevent interference with communication systems. If there is an Airplane Mode, it should be enabled prior to boarding an aircraft. Please consult the airline staff for more restrictions on the use of wireless devices on an aircraft.



Wireless devices may cause interference on sensitive medical equipment, so please be aware of the restrictions on the use of wireless devices when in hospitals, clinics or other healthcare facilities.



Cellular terminals or mobiles operating over radio signal and cellular network cannot be guaranteed to connect in certain conditions, such as when the mobile bill is unpaid or the (U)SIM card is invalid. When emergency help is needed in such conditions, use emergency call if the device supports it. In order to make or receive a call, the cellular terminal or mobile must be switched on in a service area with adequate cellular signal strength. In an emergency, the device with emergency call function cannot be used as the only contact method considering network connection cannot be guaranteed under all circumstances.



The cellular terminal or mobile contains a transceiver. When it is ON, it receives and transmits radio frequency signals. RF interference can occur if it is used close to TV sets, radios, computers or other electric equipment.



In locations with explosive or potentially explosive atmospheres, obey all posted signs and turn off wireless devices such as mobile phone or other cellular terminals. Areas with explosive or potentially explosive atmospheres include fuelling areas, below decks on boats, fuel or chemical transfer or storage facilities, and areas where the air contains chemicals or particles such as grain, dust or metal powders.

About the Document

Revision History

Version	Date	Author	Description
-	2023-03-17	Xu LI/ Angela HE/ Ramos ZHANG	Creation of the document
1.0.0	2023-05-26	Xu LI/ Angela HE/ Ramos ZHANG	Preliminary

Contents

Safety Information	3
About the Document	4
Contents	5
Table Index	7
Figure Index	8
1 Introduction	9
1.1. Special Mark.....	9
2 Product Overview	10
2.1. Key Features.....	10
2.2. Functional Diagram.....	12
2.3. Pins Assignment.....	13
2.4. Pins Description.....	14
2.5. EVB Kit.....	17
3 Operating Characteristics	18
3.1. Operating Modes.....	18
3.2. Power Supply.....	19
3.2.1. Power Supply Pins.....	19
3.2.2. Reference Design for Power Supply.....	19
3.2.3. Requirements for Voltage Stability.....	19
3.3. Turn on.....	21
3.4. V_BCKP*.....	21
4 Application Interfaces	23
4.1. UART Interface.....	23
4.2. I2C Interface*.....	24
4.3. 1PPS*.....	25
4.4. System Pins.....	25
4.4.1. WAKEUP_IN.....	25
4.4.2. BOOT.....	26
4.4.3. RESET_N.....	27
4.5. ADC Interface.....	29
4.6. Indication Signal.....	30
4.6.1. Network Status Indication*.....	30
4.6.2. STATUS.....	31
4.6.3. EVENT_IND*.....	31
5 RF Specifications	33
5.1. Antenna Interface.....	33
5.1.1. Antenna Interface & Frequency Bands.....	33
5.1.2. Reference Design of Passive Antenna.....	34
5.1.3. Requirements for Antenna Design.....	34

5.2.	Satellite L–Band Network.....	35
5.2.1.	Transmitting Power	35
5.2.2.	Receiver Parameter	35
5.3.	GNSS	35
5.3.1.	GNSS Performance	35
5.3.2.	AGNSS	37
5.3.2.1.	EASY™	37
5.3.2.2.	EPO™	37
5.4.	RF Routing Guidelines	37
5.5.	RF Connector Recommendation	39
6	Electrical Characteristics and Reliability	41
6.1.	Absolute Maximum Ratings	41
6.2.	Power Supply Ratings.....	42
6.3.	Operating and Storage Temperatures.....	42
6.4.	Power Consumption	42
6.5.	Digital I/O Characteristics.....	43
6.6.	ESD Protection.....	44
6.7.	Thermal Dissipation.....	44
7	Mechanical Information.....	46
7.1.	Mechanical Dimensions	46
7.2.	Recommended Footprint.....	48
7.3.	Top and Bottom Views.....	49
8	Storage, Manufacturing & Packaging.....	50
8.1.	Storage Conditions.....	50
8.2.	Manufacturing and Soldering	51
8.3.	Packaging Specification	53
8.3.1.	Carrier Tape.....	53
8.3.2.	Plastic Reel	54
8.3.3.	Mounting Direction	54
8.3.4.	Packaging Process	55
9	Appendix References	56

Table Index

Table 1: Special Mark.....	9
Table 2: Basic Information.....	10
Table 3: Key Features.....	10
Table 4: Parameters Definition.....	14
Table 5: Pins Description.....	14
Table 6: VBAT and GND Pins.....	19
Table 7: UART Information.....	23
Table 8: Pin Description of UART.....	23
Table 9: Pin Description of I2C Interface.....	25
Table 10: Pin Description of WAKEUP_IN Interface.....	26
Table 11: Pin Description of BOOT.....	26
Table 12: Operating Modes.....	26
Table 13: Pin Description of RESET_N.....	27
Table 14: Pin Description of ADC Interface.....	29
Table 15: Characteristics of ADC Interface.....	29
Table 16: Pins Description of Indication Signal.....	30
Table 17: Network Status Indication Pin Level and Module Network Status.....	30
Table 18: Pins Description of Antenna Interface.....	33
Table 19: L-Band Frequency (Unit: MHz).....	33
Table 20: GNSS Frequency (Unit: MHz).....	33
Table 21: Requirements for Antenna Design.....	34
Table 22: RF Transmitting Power.....	35
Table 23: C/No and Rx gain.....	35
Table 24: GNSS Performance.....	35
Table 25: Absolute Maximum Ratings.....	41
Table 26: Module's Power Supply Ratings.....	42
Table 27: Recommended Operating Temperature.....	42
Table 28: Power Consumption.....	42
Table 29: Common I/O Characteristics (Unit: V).....	43
Table 30: VDD_EXT I/O Characteristics (Unit: V).....	43
Table 31: ESD Characteristics (Temperature: 25–30 °C, Humidity: 40 ±5 %; Unit: kV).....	44
Table 32: Recommended Junction Operating Temperature Range for Main Chips (Unit: °C).....	45
Table 33: Recommended Thermal Profile Parameters.....	52
Table 34: Carrier Tape Dimension Table (Unit: mm).....	53
Table 35: Plastic Reel Dimension Table (Unit: mm).....	54
Table 36: Related Documents.....	56
Table 37: Terms and Abbreviations.....	56

Figure Index

Figure 1: Functional Diagram..... 错误!未定义书签。

Figure 2: Pins Assignment 13

Figure 3: Reference Design of Power Input..... 19

Figure 4: Power Supply Limits During Burst Transmission..... 20

Figure 5: Reference Design of Power Supply..... 20

Figure 6: Timing of Turn On 21

Figure 7: Reference Charging Circuit with Rechargeable Backup Battery 22

Figure 8: Reference Design of UART 24

Figure 9: Reference Design of UART with Transistor Level-shifting Circuit 24

Figure 10: I2C Interface Reference Design 25

Figure 11: WAKEUP_IN Reference Design 26

Figure 12: BOOT Pin State (Normal Operating Mode) 27

Figure 13: BOOT Pin Control Sequence (Boot Download Mode) 27

Figure 14: Reference Design of Reset with Driving Circuit 28

Figure 15: Reference Design of Reset with Button..... 28

Figure 16: Timing of Reset 28

Figure 17: Reference Design of Network Status Indication..... 30

Figure 18: Reference Design of STATUS 31

Figure 19: Reference Design of EVENT_IND..... 31

Figure 20: Behavior of EVENT_IND as RI Signal..... 32

Figure 21: Reference Design of Passive Antenna 34

Figure 22: Microstrip Design on a 2-layer PCB 38

Figure 23: Coplanar Waveguide Design on a 2-layer PCB 38

Figure 24: Coplanar Waveguide Design on a 4-layer PCB (Layer 3 as Reference Ground)..... 38

Figure 25: Coplanar Waveguide Design on a 4-layer PCB (Layer 4 as Reference Ground)..... 38

Figure 26: Dimensions of the Receptacle (Unit: mm)..... 39

Figure 27: Specifications of Mated Plugs (Unit: mm) 40

Figure 28: Placement and Fixing of the Heatsink 45

Figure 29: Top and Side Dimensions 46

Figure 30: Bottom Dimensions 47

Figure 31: Recommended Footprint 48

Figure 32: Top and Bottom Views 49

Figure 33: Recommended Reflow Soldering Thermal Profile 51

Figure 34: Carrier Tape Dimension Drawing..... 53

Figure 35: Plastic Reel Dimension Drawing 54

Figure 36: Mounting Direction 54

Figure 37: Packaging Process 55

1 Introduction

This document introduces CC200A-LB module and describes its hardware interfaces which are connected to your applications.

This document helps you quickly understand the interface specifications, RF characteristics, electrical and mechanical details, as well as other related information of the module.

1.1. Special Mark

Table 1: Special Mark

Marks	Definitions
*	Unless otherwise specified, when an asterisk (*) is used after a function, feature, interface, pin name, AT command, or argument, it indicates that the function, feature, interface, pin, AT command, or argument is under development and currently not supported; and the asterisk (*) after a model indicates that the sample of the model is currently unavailable.

Hereby, [Quectel Wireless Solutions Co., Ltd.] declares that the radio equipment type [CC200A-LB] is in compliance with Directive 2014/53/EU. The full text of the EU declaration of conformity is available at the following internet address: <http://www.quectel.com/support/technical.htm>



The device could be used with a separation distance of 20cm to the human body.

2 Product Overview

CC200A-LB is a satellite communication module designed to provide communications in remote areas without cellular network coverage. The module can be applied to the following fields:

- Transportation
- Maritime
- Heavy Equipment
- Mining
- Oil and Gas
- Agriculture

Table 2: Basic Information

CC200A-LB	
Packaging type	LCC + LGA
Pin counts	177
Dimensions	(37.0 ±0.15) mm × (38.0 ±0.15) mm × (3.35 ±0.2) mm
Weight	approx. 9.4 g

2.1. Key Features

Table 3: Key Features

Categories	Descriptions
Power Supply	<ul style="list-style-type: none"> ● VBAT_BB: 5.5–6.5 V, typ. 6.0 V ● VBAT_RF: 5.5–6.5 V, typ. 6.0 V
Message	<ul style="list-style-type: none"> ● Supports sending and receiving messages between terminals and servers
UART Interfaces	<p>Main UART:</p> <ul style="list-style-type: none"> ● Used for AT command communication and data transmission

	<ul style="list-style-type: none"> ● Baud rate: 115200 bps Debug UART: <ul style="list-style-type: none"> ● Used for debug log output ● Baud rate: 115200 bps
Indication Interface	STATUS: <ul style="list-style-type: none"> ● Used for the module's operation status indication NET_STATUS*: <ul style="list-style-type: none"> ● Used for satellite network connectivity status indication EVENT_IND*: <ul style="list-style-type: none"> ● Used for URC output status indication
AT Commands	Complies with Quectel AT commands
Antenna Interfaces	<ul style="list-style-type: none"> ● Satellite and GNSS share the same antenna interface (ANT_SAT) ● 50 Ω characteristic impedance
Satellite Service	Inmarsat GEO; two-way communication, IsatData Pro (IDP) ¹
Satellite Frequency Range	L-Band <ul style="list-style-type: none"> ● Tx Frequency: 1626.5–1660.5 MHz ● Rx Frequency: 1518.0–1559.0 MHz
GNSS Features	<ul style="list-style-type: none"> ● GPS L1/BDS B1/GLONASS L1/Galileo E1 ● The data update rate is 1 Hz by default and can support a maximum value of 10 Hz
Temperature Ranges	<ul style="list-style-type: none"> ● Normal operating temperature ²: -35 °C to +75 °C ● Extended temperature ²: -40 °C to +85 °C ● Storage temperature: -40 °C to +90 °C
Firmware Upgrade	UART interface
RoHS	All hardware components are fully compliant with EU RoHS directive

¹ IsatData Pro (IDP) service is provided by Orbcomm.

² To meet this operating temperature range requirements, it is necessary to ensure effective thermal dissipation, e.g., by adding passive or active heatsinks, heat pipes, vapor chambers, etc.

2.2. Functional Diagram

The following figure shows a block diagram of the module.

- Power management
- Baseband
- 4 MB flash
- Radio frequency
- Peripheral interfaces

2.3. Pins Assignment

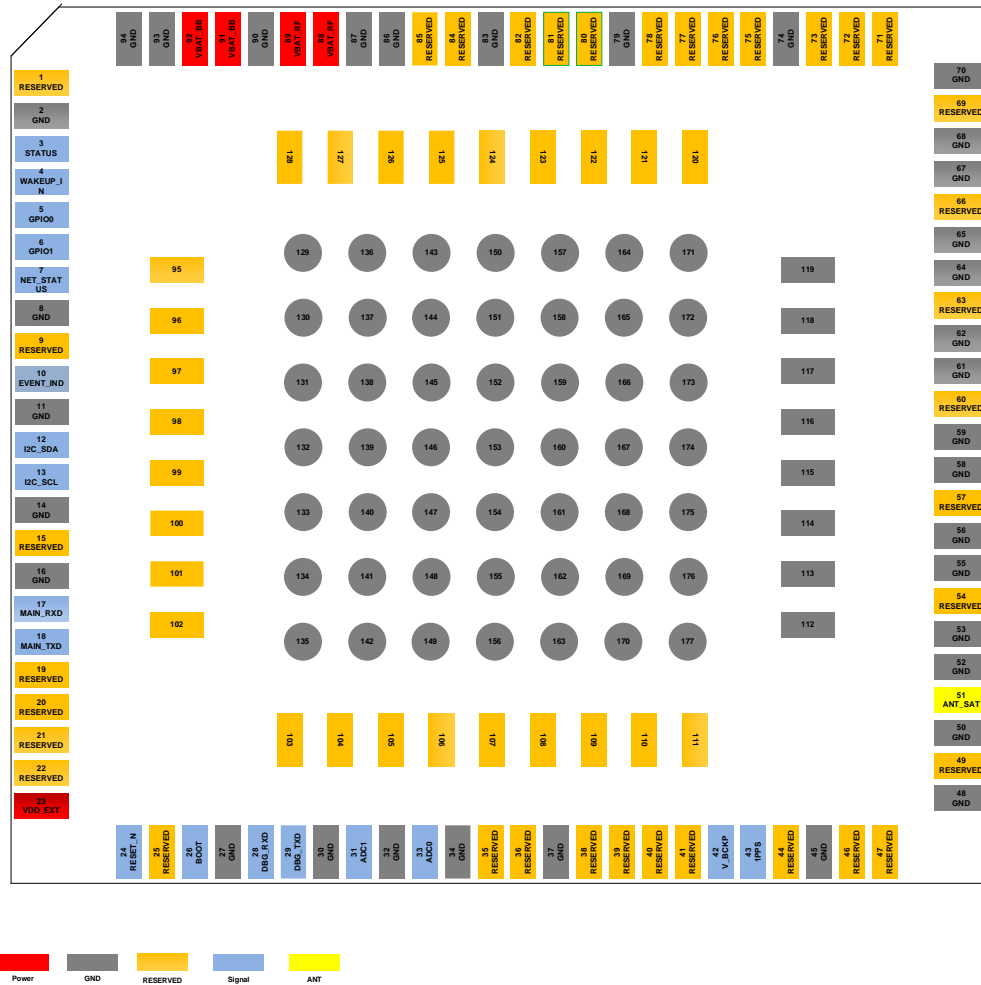

Figure 1: Pins Assignment

NOTE

Keep all RESERVED pins unconnected.

2.4. Pins Description

Table 4: Parameters Definition

Parameters	Descriptions
AI	Analog Input
AO	Analog Output
AIO	Analog Input/Output
DI	Digital Input
DO	Digital Output
DIO	Digital Input/Output
OD	Open Drain
PI	Power Input
PO	Power Output

DC characteristics include power domain and rate current in the table below.

Table 5: Pins Description

Power Supply Input					
Pin Name	Pin No.	I/O	Description	DC Characteristics	Comment
VBAT_BB	91, 92	PI	Power supply for the module's baseband part	Vmax = 6.5 V Vmin = 5.5 V Vnom = 6.0 V	
VBAT_RF	88, 89	PI	Power supply for the module's RF part	Vmax = 6.5 V Vmin = 5.5 V Vnom = 6.0 V	
V_BCKP*	42	PI	Backup power supply for backup domain	Vmin = 1.65 V Vnom = 3.3 V Vmax = 3.6 V	Internally connected to 3.3 V. It should always be powered by an external battery if hot (warm) start is required, if not,

keep it unconnected.

Power Output

Pin Name	Pin No.	I/O	Description	DC Characteristics	Comment
VDD_EXT	23	PO	Provide 3.3 V for external circuit	Vnom = 3.3 V Imax = 50 mA	Power supply for external GPIO's pull-up circuits. A test point is recommended to be reserved.

GND

Pin Name	Pin No.
GND	2, 8, 11, 14, 16, 27, 30, 32, 34, 37, 45, 48, 50, 52, 53, 55, 56, 58, 59, 61, 62, 64, 65, 67, 68, 70, 74, 79, 83, 86, 87, 90, 93, 94, 112–119, 129–177

Reset

Pin Name	Pin No.	I/O	Description	DC Characteristics	Comment
RESET_N	24	DI	Reset the module	VDD_EXT	Internally pulled up to 3.3 V. Active low. A test point is recommended to be reserved if unused.

Indication Interface

Pin Name	Pin No.	I/O	Description	DC Characteristics	Comment
STATUS	3	DO	Indicate the module's operation status	VDD_EXT	
NET_STATUS*	7	DO	Indicate the module's network activity status	VDD_EXT	
EVENT_IND*	10	DO	Indicate the module's URC output status	VDD_EXT	

Main UART Interface

Pin Name	Pin No.	I/O	Description	DC Characteristics	Comment
MAIN_RXD	17	DI	Main UART receive	VDD_EXT	
MAIN_TXD	18	DO	Main UART transmit	VDD_EXT	

Debug UART Interface					
Pin Name	Pin No.	I/O	Description	DC Characteristics	Comment
DBG_RXD	28	DI	Debug UART receive	VDD_EXT	Test points must be reserved.
DBG_TXD	29	DO	Debug UART transmit	VDD_EXT	
I2C Interface*					
Pin Name	Pin No.	I/O	Description	DC Characteristics	Comment
I2C_SDA	12	OD	I2C serial data		External pull-up resistor is required. 3.3 V only. If unused, keep it open.
I2C_SCL	13	OD	I2C serial clock		
RF Antenna Interface					
Pin Name	Pin No.	I/O	Description	DC Characteristics	Comment
ANT_SAT	51	AIO	Satellite & GNSS antenna interface		50 Ω characteristic impedance.
ADC Interface					
Pin Name	Pin No.	I/O	Description	DC Characteristics	Comment
ADC0	33	AI	General-purpose ADC interface	0–3.3 V	Max input 3.3 V. If unused, connect it to GND directly.
ADC1	31	AI	General-purpose ADC interface	0–3.3 V	
Other Interfaces					
Pin Name	Pin No.	I/O	Description	DC Characteristics	Comment
BOOT	26	DI	Pull up to force the module into boot download mode	VDD_EXT	Internally pulled down to GND.
WAKEUP_IN	4	DI	Pull down to wake up the module	VDD_EXT	Internally pulled up.
GPIO0	5	DIO	General-purpose input/output	VDD_EXT	
GPIO1	6	DIO	General-purpose input/output	VDD_EXT	
1PPS*	43	DO	One pulse per second	0–3.3 V	Synchronized on rising edge. If unused, keep the

pin unconnected.

Reserved Pins

Pin Name	Pin No.
RESERVED	1, 9, 15, 19–22, 25, 35, 36, 38–41, 44, 46, 47, 49, 54, 57, 60, 63, 66, 69, 71–73 75–78, 80–82, 84, 85, 95–111, 120–128

2.5. EVB Kit

Quectel supplies an evaluation board (SAT-A EVB) with accessories to control or test the module. For more details, see **document [1]**.

3 Operating Characteristics

3.1. Operating Modes

The following table briefly outlines the operating modes of the module.

Mode	Details
Working Mode	By default, the module is in working mode upon powering on, allowing it to process data from the host at any time. The internal satellite and GNSS modems, as well as the power supply and RF circuit, operate periodically based on business needs. The working cycle of the modems can be configured using relevant AT commands. See document [2] for more details.
GNSS Mode	The module's main UART will continuously output NMEA sentences. The main control chip of the module and the GNSS modem, as well as related circuits, will work continuously. The satellite modem will be turned off. To exit GNSS mode, send CTRL+Z to the module.
Periodic Sleep Mode	In this mode, the module periodically checks for any pending data to process, and enters sleep mode when idle. The internal RTC alarm clock wakes up the module at set intervals to process satellite downlink messages. The module supports waking up via the default WAKEUP_IN pin pull-down, or by using AT commands to configure UART wake-up. See document [2] for more details.
Deep Sleep Mode	When the module's data service or location information is not used for a long time, the module can be configured to enter deep sleep mode. In deep sleep mode, the module can only be awakened by pulling the WAKEUP_IN pin low.

When the module is in working mode, it can be switched to any other mode. However, switching between GNSS mode, periodic sleep mode, and deep sleep mode is not supported. When exiting from GNSS mode, periodic sleep mode, and deep sleep mode, the module returns to working mode. If you want to switch from one non-working mode to another, you need to first exit the current mode and let the module enter working mode, and then switch to another mode by sending AT commands.

3.2. Power Supply

3.2.1. Power Supply Pins

The module provides 4 VBAT pins for connection with the external power supply. There are two separate voltages for VABT.

Table 6: VBAT and GND Pins

Pin Name	Pin No.	I/O	Description
VBAT_BB	91, 92	PI	Power supply for the module's baseband part
VBAT_RF	88, 89	PI	Power supply for the module's RF part
GND	2, 8, 11, 14, 16, 27, 30, 32, 34, 37, 45, 48, 50, 52, 53, 55, 56, 58, 59, 61, 62, 64, 65, 67, 68, 70, 74, 79, 83, 86, 87, 90, 93, 94, 112–119, 129–177		

3.2.2. Reference Design for Power Supply

Power design for the module is essential. The power supply of the module should be able to provide sufficient continue current of 2.5 A at least. If the voltage difference between input voltage and the supply voltage is small, it is suggested to use an LDO; If the voltage difference is big, a buck converter is recommended.

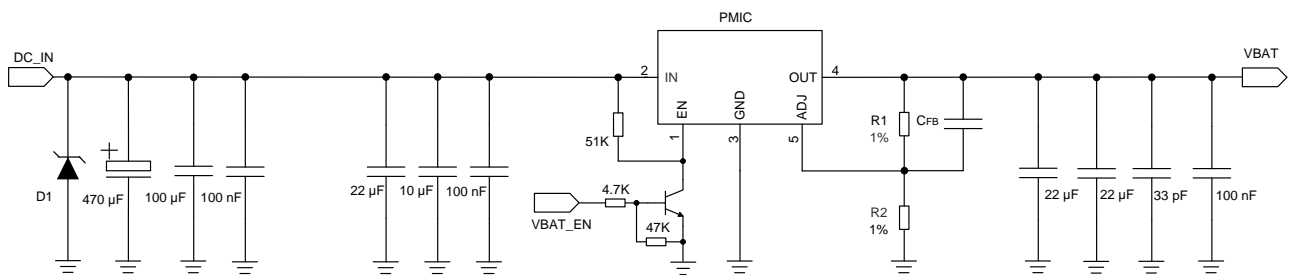

Figure 2: Reference Design of Power Input

3.2.3. Requirements for Voltage Stability

The power supply range of the module is from 5.5 V to 6.5 V. Ensure the input voltage never drops below 5.5 V.

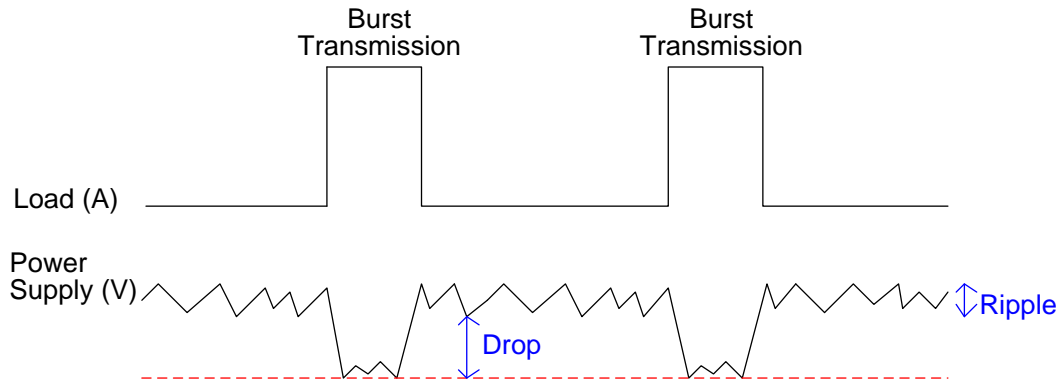

Figure 3: Power Supply Limits During Burst Transmission

To decrease the voltage drop, use a bypass capacitor of about 100 μF with low ESR and reserve a multi-layer ceramic chip (MLCC) capacitor array with ultra-low ESR. Use 3 ceramic capacitors for composing the MLCC array, and place these capacitors close to the VBAT pins. The main power supply from an external application should be a single voltage source and can be expanded to two sub paths with the star configuration. The width of VBAT_BB trace and VBAT_RF trace should be at least 1 mm and 1.5 mm respectively. As per design rules, the longer the VBAT trace is, the wider it should be.

To avoid the ripple and surge and to ensure the stability of the power supply to the module, add a high-power rated TVS component at the front end of the power supply.

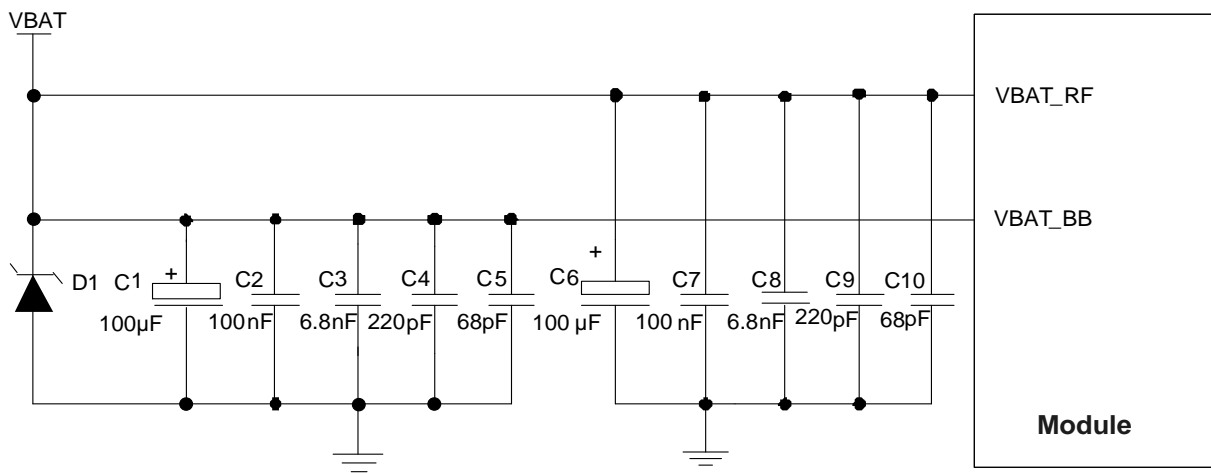

Figure 4: Reference Design of Power Supply

3.3. Turn on

After powering on the module, the module can turn on automatically. No other operation is required.

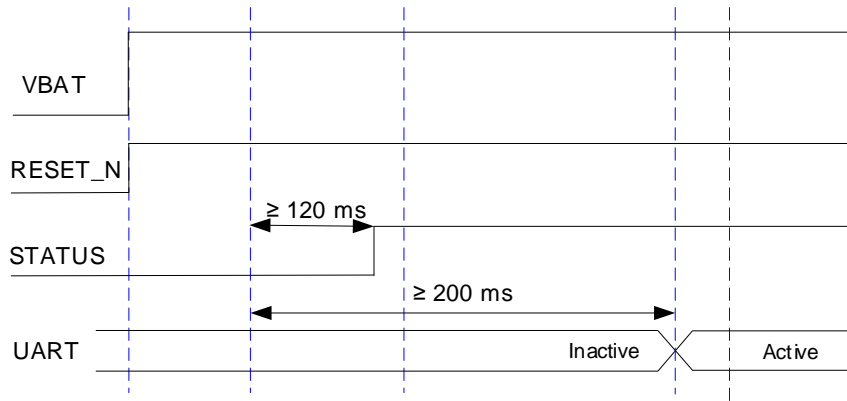

Figure 5: Timing of Turn On

3.4. V_BCKP*

The V_BCKP pin supplies the backup domain, which includes RTC and RAM. To achieve quick startup and improve TTFF, the backup domain power supply should be valid during the interval. If the VBAT is not valid, the V_BCKP supplies RAM that contains all the necessary GNSS data and some of the user configuration variables.

If there is a constant power supply in your system, it can be used to provide a suitable voltage to power V_BCKP.

It is recommended to use an external rechargeable battery for V_BCKP and place the battery with a TVS, a diode and a combination of a 4.7 μ F, a 100 nF and a 33 pF capacitor near the V_BCKP pin. The reference charging circuit is illustrated below.

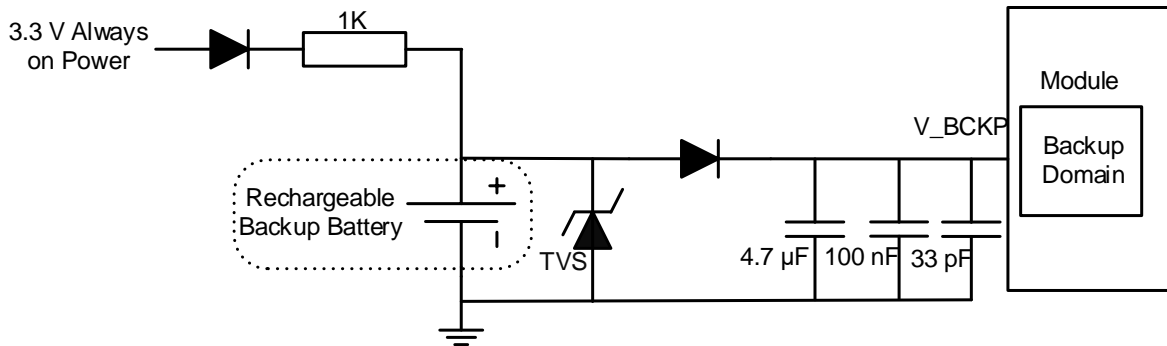

Figure 6: Reference Charging Circuit with Rechargeable Backup Battery

NOTE

1. V_BCKP pin is internally connected to 3.3 V, but it will lose power when VBAT is not connected. It should always be powered by an external battery if a hot (warm) start is required, if not, keep it unconnected.
2. In working mode and GNSS mode, the maximum current consumption of V_BCKP exceeds 100 μ A, with a portion of the current potentially sourced from an external battery. When the module is not connected to VBAT and relies on an external battery, the maximum current consumption of V_BCKP with external battery is 1 μ A, which will deplete the battery. Therefore, when using an external battery, it is recommended to configure a rechargeable battery for V_BCKP.
3. If V_BCKP is below the minimum value of the recommended operating voltage, the module cannot work normally.
4. A diode is needed between the battery and V_BCKP pin because of the inside design of this pin.
5. A 1 k Ω resistor should be used, and the resistance value of the current-limiting resistor is related to the battery selected by your application. In order to maintain the performance of the rechargeable battery, it is necessary to select 1 k Ω resistor to limit the charging current.
6. It is recommended to control the V_BCKP of the module via MCU to restart the module when the module enters an abnormal state.

4 Application Interfaces

4.1. UART Interface

The module provides two UARTs with the following features, and see the table below for details.

Table 7: UART Information

UART Type	Baud Rate (Typ.)	Functions
Main UART	115200 bps	Data transmission, AT command communication and firmware upgrade
Debug UART	115200 bps	debug log output

Table 8: Pin Description of UART

Pin Name	Pin No.	I/O	Description	Comment
MAIN_RXD	17	DI	Main UART receive	
MAIN_TXD	18	DO	Main UART transmit	3.3 V voltage domain. If the external circuit voltage does not match, a level-shifting circuit is needed.
DBG_RXD	28	DI	Debug UART receive	
DBG_TXD	29	DO	Debug UART transmit	

A reference design is shown in the figure below.

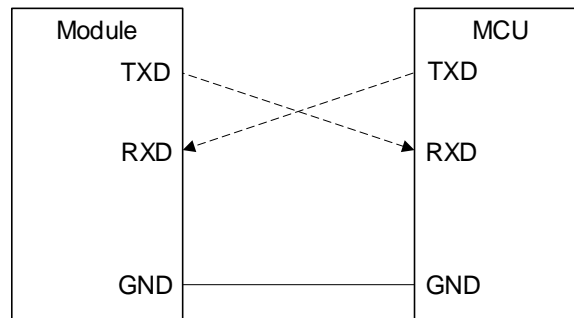

Figure 7: Reference Design of UART

The module provides 3.3 V UART. You can use level-shifting circuit between the module and host's UART if the host is equipped with a 1.8 V UART.

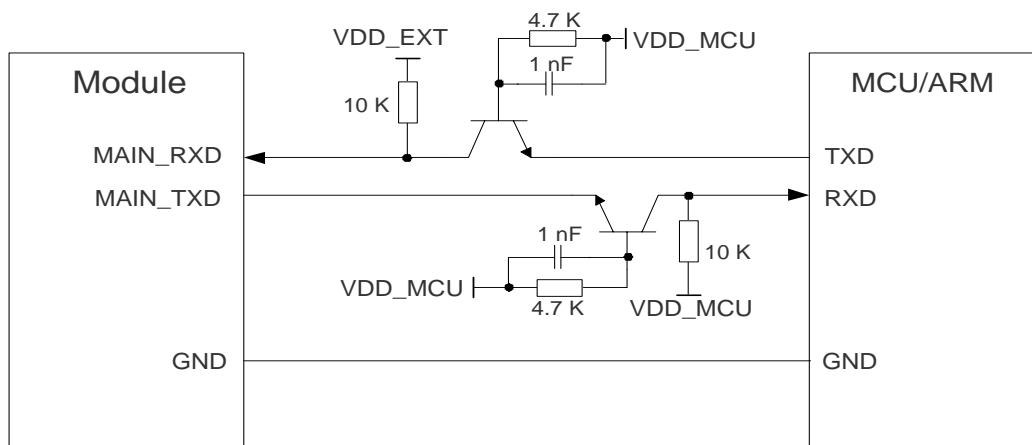

Figure 8: Reference Design of UART with Transistor Level-shifting Circuit

4.2. I2C Interface*

The module provides one I2C interface.

- Support fast mode with bit rates up to 400 kbps
- Operate as a master only.

Table 9: Pin Description of I2C Interface

Pin Name	Pin No.	I/O	Description	Comment
I2C_SDA	12	OD	I2C serial data	External pull-up resistor is required.
I2C_SCL	13	OD	I2C serial clock	3.3 V only. If unused, keep it open.

A reference design is shown in the figure below.

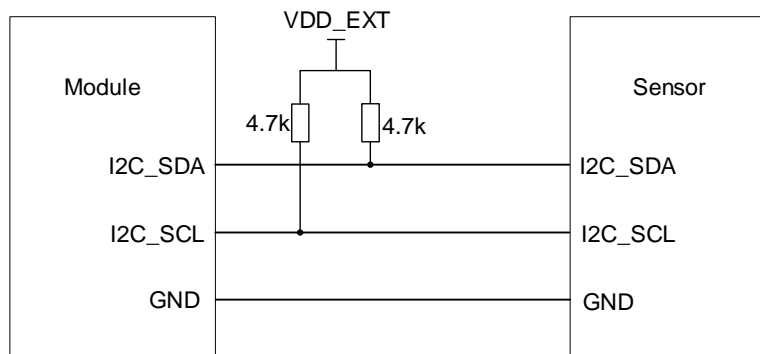

Figure 9: I2C Interface Reference Design

4.3. 1PPS*

The 1PPS output pin generates a one pulse per second periodic signal, synchronized to GNSS time grid with intervals. Pulse accuracy is better than 100 ns. Thus, it may be used as a low frequency time synchronization pulse or as a high frequency reference signal. Maintaining high accuracy of 1PPS requires visible satellites in an open sky environment and powered VBAT.

4.4. System Pins

4.4.1. WAKEUP_IN

The WAKEUP_IN pin can be used to wake up the module from sleep mode. Drive WAKEUP_IN to low voltage level and keep it low to wake up the module from sleep mode. The WAKEUP_IN pin is internally pulled up by default.

Table 10: Pin Description of WAKEUP_IN Interface

Pin Name	Pin No.	I/O	Description	Comment
WAKEUP_IN	4	DI	Pull down to wake up the module	Internally pulled up.

A reference design is shown in the figure below.

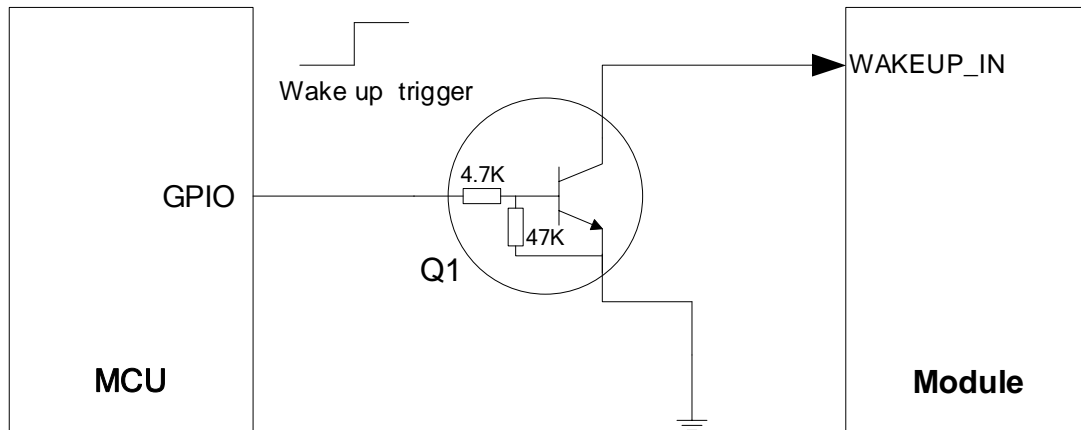

Figure 10: WAKEUP_IN Reference Design

4.4.2. BOOT

The BOOT pin can be used to set the module to the boot download mode. It is pulled down internally by default. While keeping the pin floating during startup, the module enters the normal operating mode. If the pin is kept at high level for about 100 ms during startup, the module enters the boot download mode.

Table 11: Pin Description of BOOT

Pin Name	Pin No.	I/O	Description	Comment
BOOT	26	DI	Pull up to force the module into boot download mode	Internally pulled down to GND

Table 12: Operating Modes

Voltage Level	Operating Mode	Comment
Low	Normal	Default
High	Boot download	If the pin is kept at high level more than 100 ms during startup, the module enters the boot download mode.

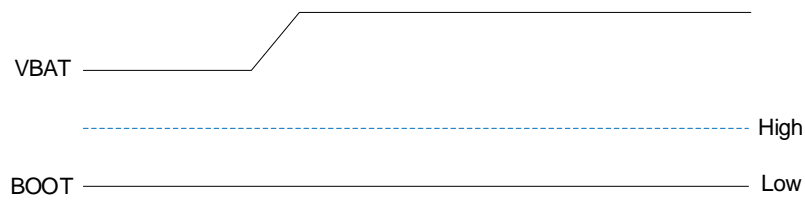

Figure 11: BOOT Pin State (Normal Operating Mode)

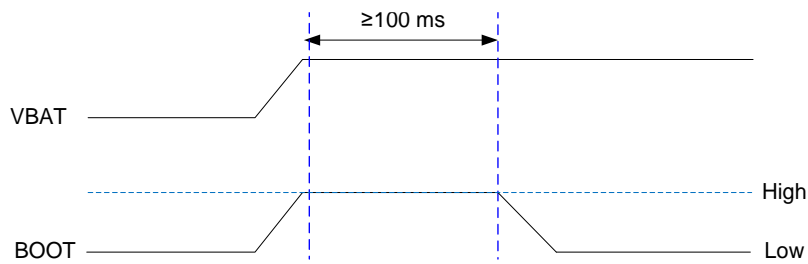

Figure 12: BOOT Pin Control Sequence (Boot Download Mode)

4.4.3. RESET_N

Drive RESET_N low at least 100 ms and then releasing it can reset the module. RESET_N signal is sensitive to interference, consequently it is recommended to route the trace as short as possible and surround it with ground.

Table 13: Pin Description of RESET_N

Pin Name	Pin No.	I/O	Description	Comment
RESET_N	24	DI	Reset the module	Internally pulled up to 3.3 V. Active low. Test point is recommended to be reserved if unused.

You can use an open drain/collector driver or a button to control RESET_N.

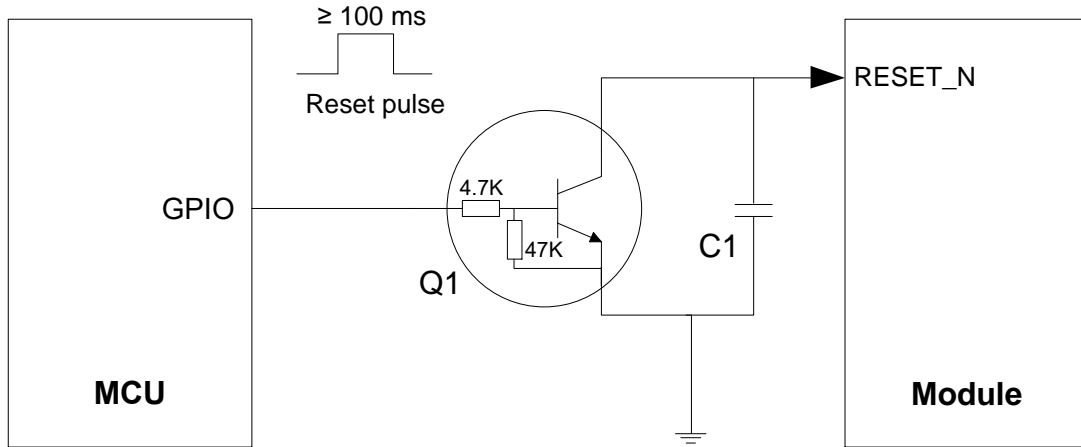

Figure 13: Reference Design of Reset with Driving Circuit

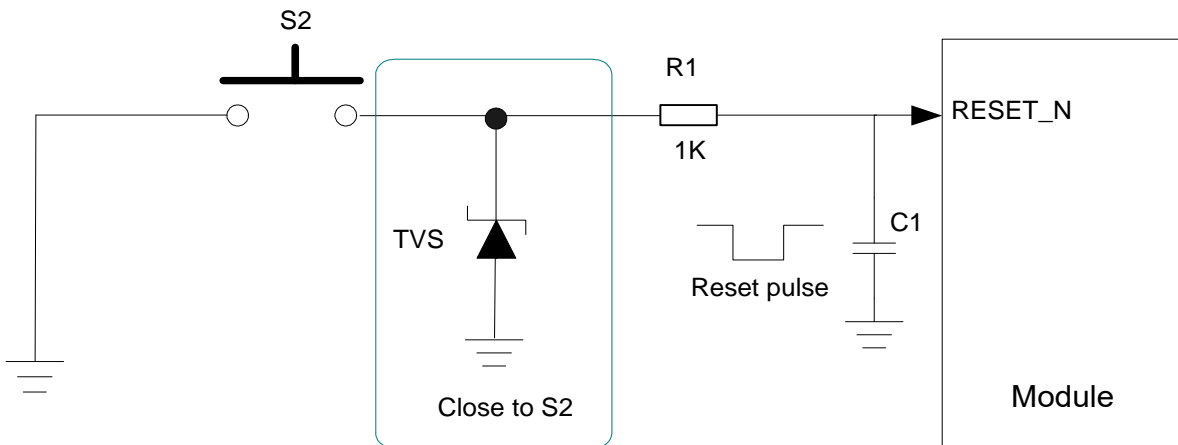

Figure 14: Reference Design of Reset with Button

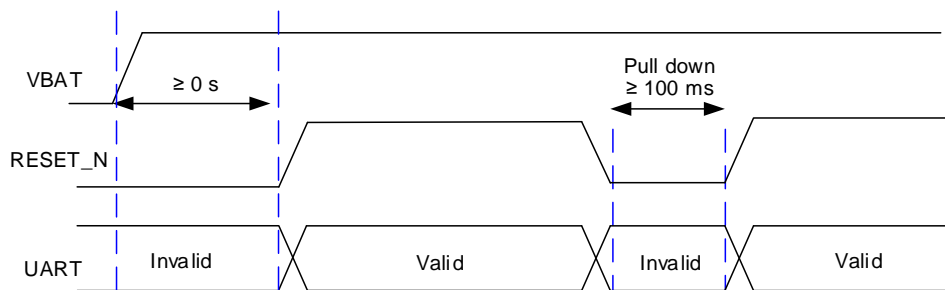

Figure 15: Timing of Reset

NOTE

Ensure the capacitance on RESET_N is no more than 10 nF.

4.5. ADC Interface

The module provides 2 ADC interfaces. To improve the accuracy of ADC, the trace of ADC interface should be surrounded by ground.

Table 14: Pin Description of ADC Interface

Pin Name	Pin No.	I/O	Description	Comment
ADC0	33	AI	General-purpose ADC interface	Max input 3.3 V. If unused, connect it to GND directly.
ADC1	31	AI	General-purpose ADC interface	

Table 15: Characteristics of ADC Interface

Parameters	Min.	Typ.	Max.	Units
ADC0 voltage range	0	-	3.3	V
ADC1 voltage range	0	-	3.3	V
ADC input resistance	-	-	1000	Ω
ADC resolution	-	14	-	bits

NOTE

1. The input voltage of every ADC interface should not exceed its corresponding voltage range.
2. It is prohibited to directly supply any voltage to ADC interface when the module is not powered by the VBAT.
3. It is recommended to use resistor divider circuit for ADC interface application. Resistance of the external resistor divider should not exceed 1 kΩ, or the measurement accuracy of ADC would be significantly reduced.

4.6. Indication Signal

Table 16: Pins Description of Indication Signal

Pin Name	Pin No.	I/O	Description
NET_STATUS*	7	DO	Indicate the module's network activity status
STATUS	3	DO	Indicate the module's operation status
EVENT_IND*	10	DO	Indicate the module's URC output status

4.6.1. Network Status Indication*

The module provides the NET_STATUS for the module's satellite network operation status indication.

This is a digital output pin which can be used to indicate the connection status and communication status between the module and the communication satellite.

Table 17: Network Status Indication Pin Level and Module Network Status

Pin Name	NET_STATUS Level Status	Module Network Status
NET_STATUS	TBD	TBD

A reference design is shown in the figure below.

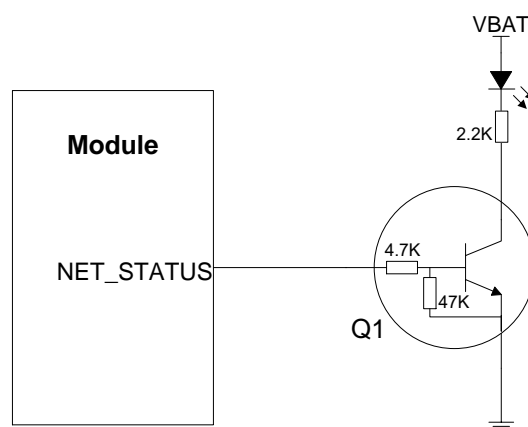

Figure 16: Reference Design of Network Status Indication

4.6.2. STATUS

The STATUS is used for indicating module's operation status. It will output high level when the module is turned on. A reference design is shown in the figure below.

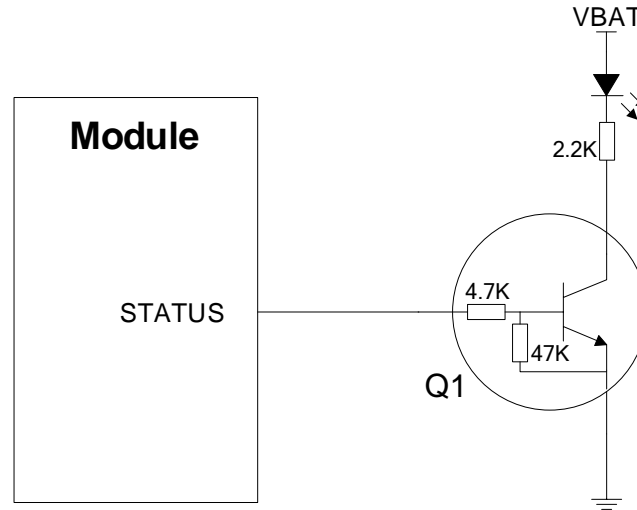

Figure 17: Reference Design of STATUS

4.6.3. EVENT_IND*

The EVENT_IND is used as RI signal to notify the host when module has URC output. The module provides 3.3 V EVENT_IND signal. A voltage-level translator should be used if your application is equipped with a 1.8 V host GPIO interface.

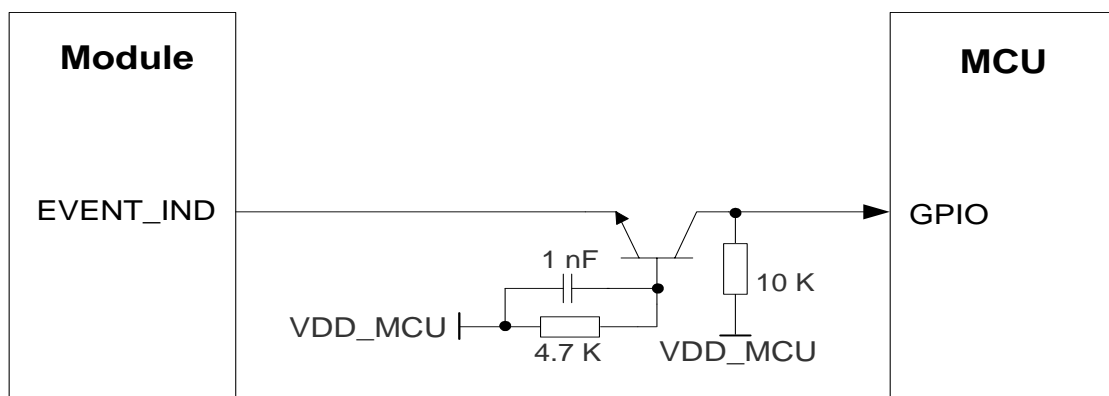

Figure 18: Reference Design of EVENT_IND

When module has URC output, the EVENT_IND pin will generate a low-level pulse to notify the host for processing. To avoid the failure of the host to receive URC in a sleep state, the URC output will be delayed by 120 ms after the RI signal wakes up the host.

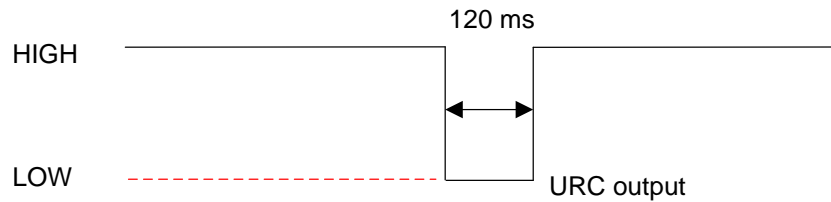

Figure 19: Behavior of EVENT_IND as RI Signal

5 RF Specifications

5.1. Antenna Interface

5.1.1. Antenna Interface & Frequency Bands

Table 18: Pins Description of Antenna Interface

Pin Name	Pin No.	I/O	Description	Comment
ANT_SAT	51	AIO	Satellite & GNSS antenna interface	50 Ω characteristic impedance

Table 19: L-Band Frequency (Unit: MHz)

Operating Frequency	Transmit	Receive
L-Band	1626.5–1660.5	1518–1559

Table 20: GNSS Frequency (Unit: MHz)

Type	Frequency
GPS	1575.42 ±1.023 (L1)
GLONASS	1597.5–1605.8 (L1)
BDS	1561.098 ±2.046 (B1I)
Galileo	1575.42 ±2.046 (E1)

5.1.2. Reference Design of Passive Antenna

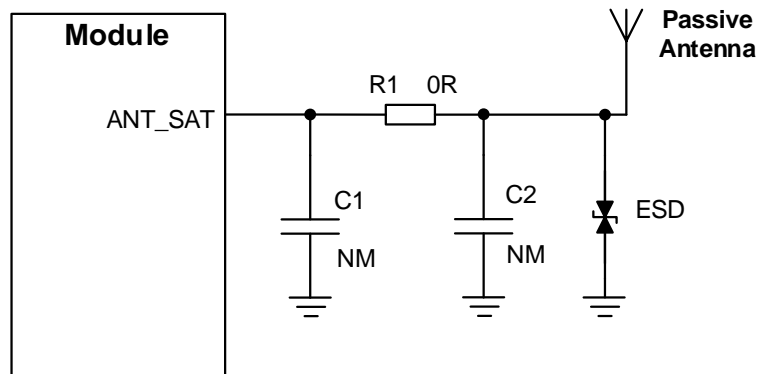

Figure 20: Reference Design of Passive Antenna

NOTE

1. To improve receiver sensitivity, ensure that the clearance among antennas is appropriate.
2. Use a π -type matching circuit for all the antenna interfaces for better RF performance and debugging.
3. Capacitors are not mounted by default.
4. Place the π -type matching components (C1, R1, C2) to antennas as close as possible.
5. Junction capacitance of ESD protection components on the antenna interface should not exceed 0.05 pF.
6. Passive antenna is recommended. If Active antenna is required, please contact Quectel Technical Support.

5.1.3. Requirements for Antenna Design

Table 21: Requirements for Antenna Design

Antenna Types	Requirements
Satellite & GNSS	<p>Frequency range: Satellite Tx: 1626.5–1660.5 MHz Satellite Rx: 1518–1559 MHz GNSS Rx: 1559–1606 MHz RHCP polarization VSWR: < TBD (Typ.)</p> <hr/> <p>For passive antenna usage: Passive antenna gain: < TBD dBic</p>

5.2. Satellite L-Band Network

5.2.1. Transmitting Power

Table 22: RF Transmitting Power

Band	Frequency (MHz)	Typ.
L-Band	1626.5–1660.5	32 dBm ±1 dB

Averaged power, tested with random modulated signal.
 CW power =31 dBm ±1 dBm

5.2.2. Receiver Parameter

Table 23: C/No and Rx gain

Frequency (MHz)	C/No (Typ.)	Rx gain (Typ.)
1518	39 dB/Hz	87 dB
1538.5	39.5 dB/Hz	87 dB
1559	39.5 dB/Hz	87 dB

5.3. GNSS

GNSS information of the module is as follows:

- Supports GPS, GLONASS, BDS, Galileo positioning system.
- Supports NMEA 0183 protocol and outputs NMEA sentences via UART interface (data update rate for positioning: 1–10 Hz, 1 Hz by default).

5.3.1. GNSS Performance

Table 24: GNSS Performance

Parameter	Specification	Typ.	Unit
Power Consumption ³ (GPS + GLONASS + Galileo + BDS)	Acquisition	TBD	mA
	Tracking	TBD	mA

Parameter	Specification	Typ.	Unit
	Backup Mode	TBD	μA
Sensitivity (GPS + GLONASS + Galileo + BDS)	Acquisition	-146	dBm
	Reacquisition	-158	dBm
	Tracking	-164	dBm
TTFF ³ (without AGNSS)	Cold Start	32	s
	Warm Start	3	s
	Hot Start	2	s
TTFF ⁴ (with EASY™)	Cold Start	TBD	s
	Warm Start	TBD	s
	Hot Start	TBD	s
TTFF ⁴ (with Flash EPO™)	Cold Start	TBD	s
Horizontal Position Accuracy ⁵	-	2	m
Accuracy of 1PPS Signal ³	-	TBD	ns
Velocity Accuracy ³	Without Aid	TBD	m/s
Acceleration Accuracy ³	Without Aid	TBD	m/s ²
Dynamic Performance ³	Maximum Altitude	TBD	m
	Maximum Velocity	TBD	m/s
	Maximum Acceleration	TBD	g

NOTE

1. Tracking sensitivity: the minimum GNSS signal power at which the module can maintain lock of navigation signals (keep positioning for at least 3 minutes continuously).
2. Reacquisition sensitivity: the minimum GNSS signal power required for the module to maintain lock of navigation signals within 3 minutes after loss of lock.
3. Acquisition sensitivity: the minimum GNSS signal power at which the module can fix position of navigation signals successfully within 3 minutes after executing cold start command.
4. Junction capacitance of ESD protection components on the antenna interface should not exceed

⁴ Open-sky.

⁵ CEP, 50 %, 24 hours static, -130 dBm, more than 6 SVs.

0.05 pF.

5. It is recommended to use a passive GNSS antenna, as the use of active antenna may generate harmonics which will affect the GNSS performance.

5.3.2. AGNSS

The module supports AGNSS feature that significantly reduces the module's TTFF, especially under lower signal conditions. To implement the AGNSS feature, the module should get the assistance data including the current time and rough position.

5.3.2.1. EASY™

The module supports the EASY™ technology to improve TTFF by providing ancillary information, such as ephemeris and almanac. The EASY™ technology works as an embedded software to accelerate TTFF by predicting satellite navigation messages from the received ephemeris. After receiving the broadcast ephemeris for the first time, the GNSS engine automatically calculates and predicts the orbit information for up to 3 subsequent days, and saves the predicted information in the internal memory. The GNSS engine will use the information for positioning if there is not enough information from satellites, resulting in improved positioning and TTFF.

The EASY™ function reduces TTFF to 2 s in warm start. In this case, the backup domain should still be valid. To obtain enough broadcast ephemeris information from GNSS satellites, in strong-signal environments the GNSS module should keep tracking the information for at least 5 minutes after fixing the position. The EASY™ function is enabled by default.

5.3.2.2. EPO™

The module features a leading AGNSS technology called EPO™, which assists the receiver to reduce the TTFF for up to 14 days.

5.4. RF Routing Guidelines

When designing PCB, characteristic impedance of all RF traces should be controlled to 50 Ω. Generally, the impedance of RF traces is determined by materials' dielectric constant, trace width (W), spacing between RF traces and grounds (S) and height from the reference ground to the signal layer (H). Microstrip or coplanar waveguide is typically used in RF layout to control characteristic impedance. The following are reference designs of microstrip or coplanar waveguide with different PCB structures when characteristic impedance of RF traces is controlled to 50 Ω.

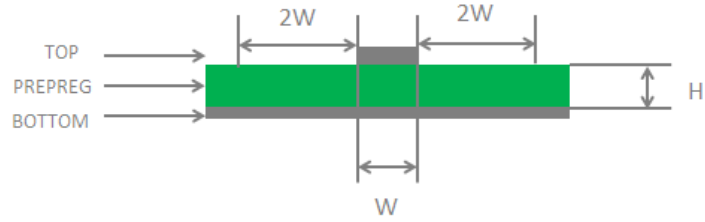

Figure 21: Microstrip Design on a 2-layer PCB

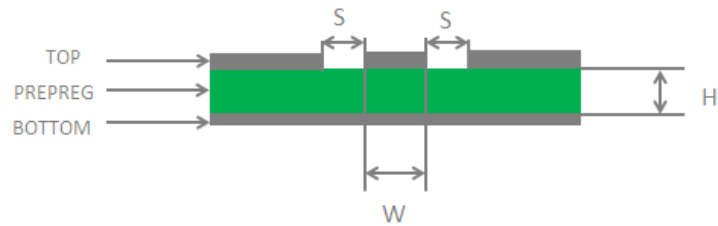

Figure 22: Coplanar Waveguide Design on a 2-layer PCB

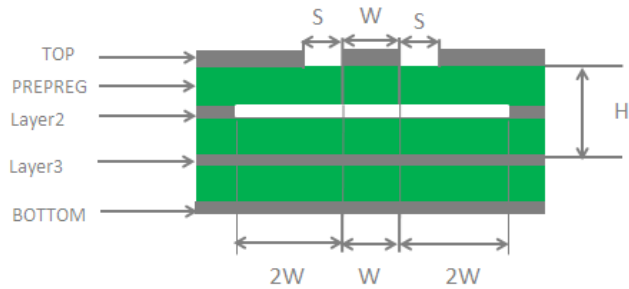

Figure 23: Coplanar Waveguide Design on a 4-layer PCB (Layer 3 as Reference Ground)

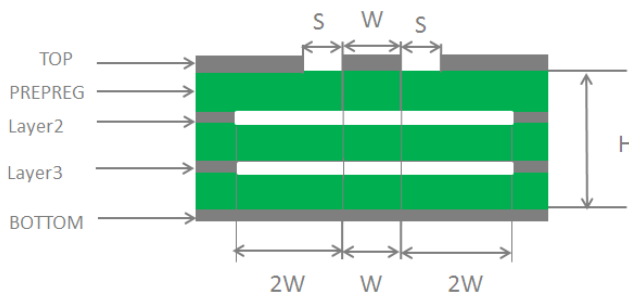

Figure 24: Coplanar Waveguide Design on a 4-layer PCB (Layer 4 as Reference Ground)

To ensure better RF performance and reliability, the following conditions should be complied with in RF

layout design:

- Use an impedance simulation tool to accurately control the characteristic impedance of RF traces to 50 Ω.
- GND pins adjacent to RF pins should not be designed as thermal relief pads, and should be fully connected to ground.
- Clearance between RF pins and RF connector should be as short as possible, and all right-angle (90°) traces should be changed to the ones with the angle of 135°.
- There should be clearance under the signal pin of the antenna connector or solder joint.
- The reference ground of RF traces should be complete. Meanwhile, ground vias around RF traces and the reference ground can improve RF performance. The clearance between ground vias and RF traces should be at least twice the width of RF signal traces (2 × W).
- Keep RF traces away from interference sources, and avoid intersection and paralleling between any traces on adjacent layers.

For more details about RF layout, see **document [3]**.

5.5. RF Connector Recommendation

If the RF connector is used for antenna connection, it is recommended to use MHF 4L receptacle provided by I-PEX.

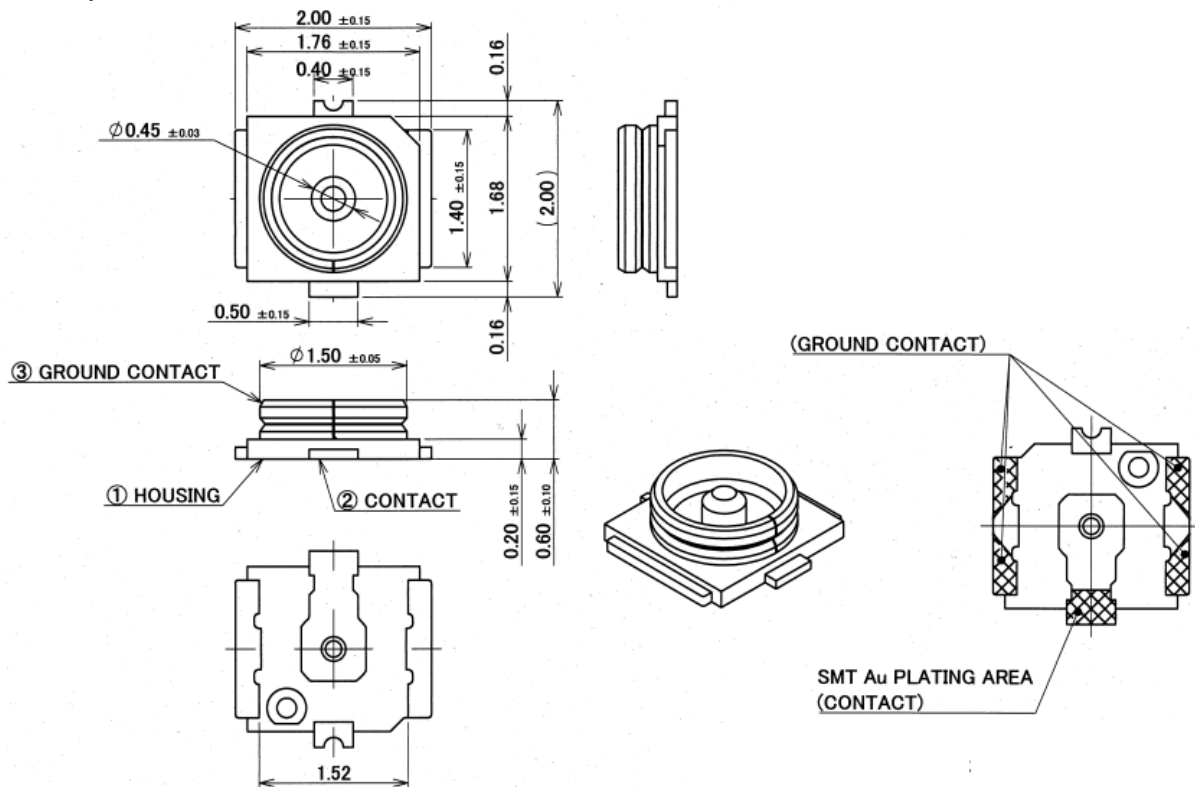
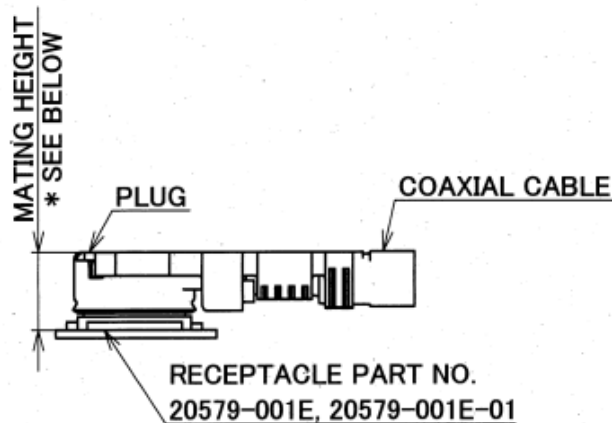

Figure 25: Dimensions of the Receptacle (Unit: mm)

MHF 4L series mated plugs listed in the following figure can be used to match the MHF 4L Receptacle.



- * MATING HEIGHT
- 1.2 MAX. WITH 20611-001R, 20572-001R-08,
20448-00*R-081, 20448-001R-081E
- 1.4 MAX. WITH 20565-001R-**
- 1.7 MAX. WITH 20632-001R-37

MATING CONDITION
WITH MHF 4/MHF 4L PLUG
(S = 10/1)

FOR MHF 4L PLUG

ITEMS	SPECIFICATION	
APPLICABLE CONNECTOR PART No.	20572-001R-08 (CABLE Φ0.81 TYPE)	20565-001E-13 (CABLE Φ1.13 TYPE)
RATING VOLTAGE	60 V AC (R.M.S)/DC	
RATING FREQUENCY	DC ~ 6GHz	
OPERATING TEMPERATURE	233~363 K(-40°C~+90°C)	
VSWR	1.3 MAX. AT DC~3GHz, 1.4 MAX. AT 3~6GHz, 1.85 MAX. AT 3~12GHz	
MAIN CONTACT RESISTANCE	INITIAL : 20 mohm MAX. / AFTER TEST : ΔR 20 mohm MAX.	
GROUND CONTACT RESISTANCE	INITIAL : 20 mohm MAX. / AFTER TEST : ΔR 20 mohm MAX.	
INSULATION RESISTANCE	INITIAL : 500 Mohm MIN. / AFTER TEST : 100 Mohm MIN.	
DIELECTRIC WITHSTANDING VOLTAGE	200 V AC 1 MINUTE	
DURABILITY	30 CYCLES	
MATING FORCE (INITIAL / AFTER TEST)	INITIAL : 30 N MAX. / AFTER TEST : 30 N MAX.	
UNMATING FORCE (INITIAL / AFTER TEST)	INITIAL : 20 N MAX. 5 N MIN. / AFTER TEST : 20 N MAX. 3 N MIN.	
PRODUCT SPECIFICATION	PRS-1907	
TEST REPORT	TR-14097	
PACKING STANDARD	20579-001E: PST-14004 20579-001E-01: PST-14067	
INSTRUCTION MANUAL	HIM-12011	HIM-12012

Figure 26: Specifications of Mated Plugs (Unit: mm)

For more details, please visit <http://www.i-pex.com>.

6 Electrical Characteristics and Reliability

6.1. Absolute Maximum Ratings

Absolute maximum ratings for power supply and voltage on digital pins of CC200A-LB module are listed in the table below.

Table 25: Absolute Maximum Ratings

Parameter	Min.	Max.	Unit
VBAT_BB	-0.3	8.0	V
VBAT_RF	-0.3	8.0	V
Voltage at digital pins	-0.3	3.63	V
Voltage at ADC0	-0.3	3.63	V
Voltage at ADC1	-0.3	3.63	V

NOTE

Stresses in excess of "Absolute Maximum Ratings" to the device may cause permanent damage. This product does not provide overvoltage or reverse voltage protection. Therefore, it is necessary to use appropriate protection diodes to keep the voltage spikes within the parameters given in the table above.

6.2. Power Supply Ratings

Table 26: Module's Power Supply Ratings

Parameter	Description	Min.	Typ.	Max.	Unit
VBAT_BB	Power supply for the module's baseband part	5.5	6.0	6.5	V
VBAT_RF	Power supply for the module's RF part	5.5	6.0	6.5	V

6.3. Operating and Storage Temperatures

All specifications are based on an ambient temperature of +25 °C. Extreme operating temperatures can significantly affect the specified values. Applications operating near the temperature limits should be tested to ensure the validity of the specification.

Table 27: Recommended Operating Temperature

Parameter	Min.	Typ.	Max.
Normal Operating Temperature ⁶	-35	+25	+75
Extended Operating Temperature ⁶	-40	+25	+85
Storage Temperature	-40	-	+90

6.4. Power Consumption

Table 28: Power Consumption

Modes	Conditions	Avg.	Max.	Units
OFF state	Power off	TBD	TBD	µA
Working Mode	Power on	TBD	TBD	mA

⁶ To meet this operating temperature range requirements, it is necessary to ensure effective thermal dissipation, e.g., by adding passive or active heatsinks, heat pipes, vapor chambers, etc.

GNSS Mode	AT+QMOD=2	42	48	mA
Periodic Sleep Mode	AT+QMOD=3	TBD	TBD	mA
Deep Sleep Mode	AT+QSCLK=1 & WAKEUP_IN HIGH	200	2000	μA
Satellite data transmission	@ 31 dBm	1.3	1.8	A
Satellite data reception	@ -132 dBm	180	180	mA

NOTE

1. The power consumption data above is for reference only, which may vary among different modules. For detailed information, contact Quectel Technical Support for the power consumption test report of the specific module.
2. When the module is in working mode, it can be switched to other modes. You cannot switch between GNSS mode, periodic sleep mode and deep sleep mode. See **document [2]** for more details.

6.5. Digital I/O Characteristics

Table 29: Common I/O Characteristics (Unit: V)

Parameter	Description	Min.	Typ.	Max.
IO_Domain	Digital IO Pin Domain Voltage	0	3.3	3.63
V _{IL}	Digital IO Pin Low-Level Input Voltage	0	-	1.08
V _{IH}	Digital IO Pin High-Level Input Voltage	2.31	-	3.63
V _{OL}	Digital IO Pin Low-Level Output Voltage	-	-	0.4
V _{OH}	Digital IO Pin High-Level Output Voltage	2.4	-	3.3

Table 30: VDD_EXT I/O Characteristics (Unit: V)

Parameters	Descriptions	Min.	Max.
V _{IH}	High-level input voltage	0.7 × VDD_EXT	VDD_EXT + 0.3

V _{IL}	Low-level input voltage	-0.3	0.3 × VDD_EXT
V _{OH}	High-level output voltage	VDD_EXT - 0.4	-
V _{OL}	Low-level output voltage	-	0.4

6.6. ESD Protection

Static electricity occurs naturally and it may damage the module. Therefore, applying proper ESD countermeasures and handling methods is imperative. For example, wear anti-static gloves during the development, production, assembly, and testing of the module; add ESD protection components to the ESD sensitive interfaces and points in the product design.

Table 31: ESD Characteristics (Temperature: 25–30 °C, Humidity: 40 ±5 %; Unit: kV)

Test Point	Contact Discharge	Air Discharge
VBAT & GND	±5	±10
ANT_SAT	±4	±8
Other interfaces	±0.5	±1

6.7. Thermal Dissipation

The module offers the best performance when all internal IC chips are working within their operating temperatures. When the IC chip reaches or exceeds the maximum junction temperature, the module may still work but the performance and functions (such as RF output power, data rate, etc.) will be affected to a certain extent. Therefore, the thermal design should be maximally optimized to ensure all internal IC chips always work within the recommended operating temperature range. The following principles for thermal consideration are provided for reference:

- Keep the module away from heat sources on your PCB, especially high-power components such as processor, power amplifier, and power supply.
- Maintain the integrity of the PCB copper layer and drill as many thermal vias as possible.
- Follow the principles below when the heatsink is necessary:
 - Do not place large size components in the area where the module is mounted on your PCB to reserve enough place for heatsink installation.
 - Attach the heatsink to the shielding cover of the module; In general, the base plate area of the

- heatsink should be larger than the module area to cover the module completely;
- Choose the heatsink with adequate fins to dissipate heat;
 - Choose a TIM (Thermal Interface Material) with high thermal conductivity, good softness and good wettability and place it between the heatsink and the module;
 - Fasten the heatsink with four screws to ensure that it is in close contact with the module to prevent the heatsink from falling off during the drop, vibration test, or transportation.

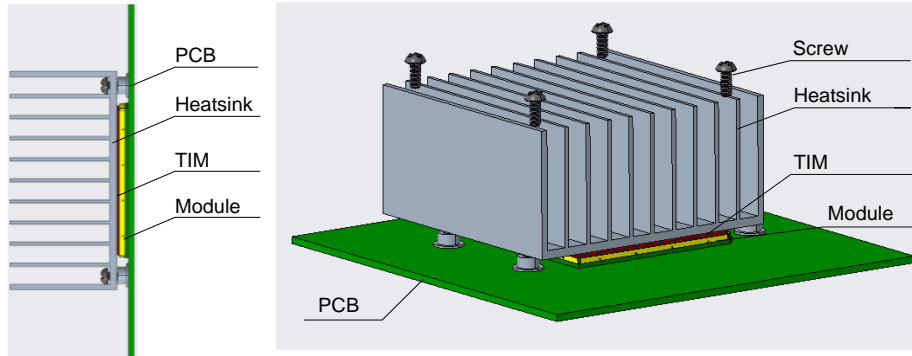

Figure 27: Placement and Fixing of the Heatsink

Table 32: Recommended Junction Operating Temperature Range for Main Chips (Unit: °C)

BB	PMU	RFIC	PA
-40 to +105	-40 to +125	-40 to +95	-40 to +175

7 Mechanical Information

This chapter describes the mechanical dimensions of the module. All dimensions are measured in millimeter (mm), and the dimensional tolerances are ± 0.2 mm unless otherwise specified.

7.1. Mechanical Dimensions

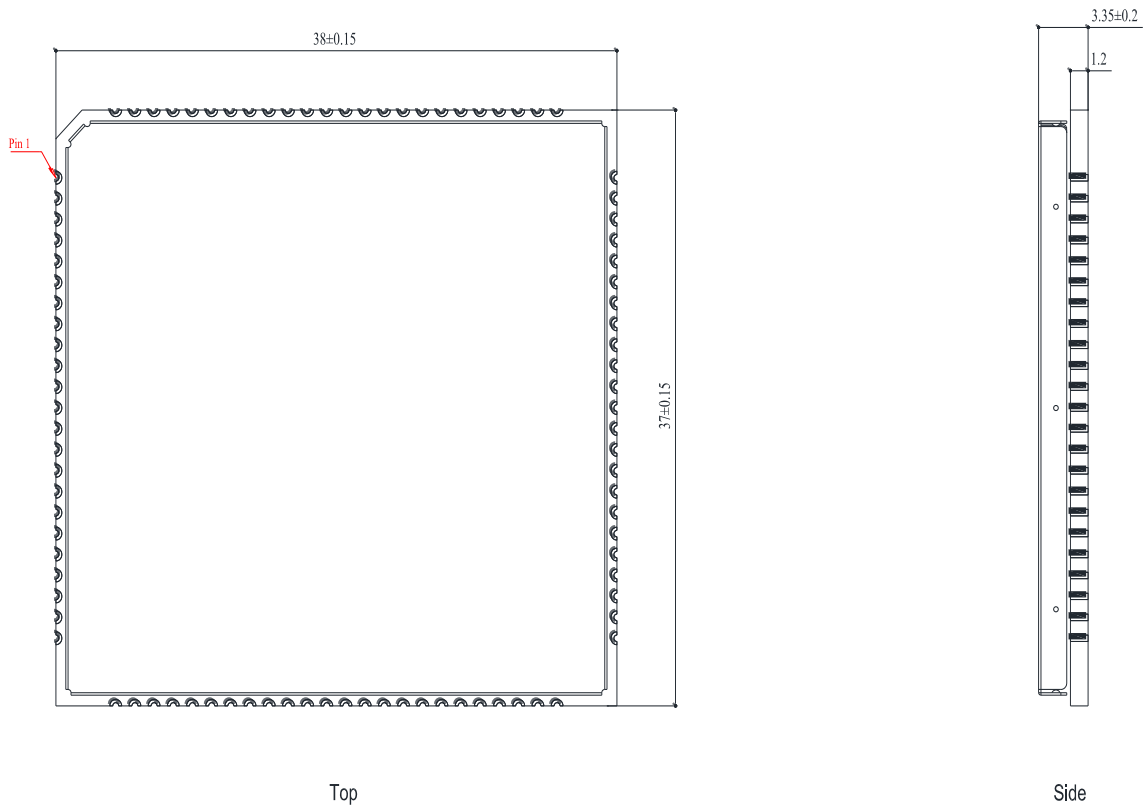

Figure 28: Top and Side Dimensions

7.3. Top and Bottom Views



Figure 31: Top and Bottom Views

NOTE

Images above are for illustration purpose only and may differ from the actual module. For authentic appearance and label, please refer to the module received from Quectel.

8 Storage, Manufacturing & Packaging

8.1. Storage Conditions

The module is provided with vacuum-sealed packaging. MSL of the module is rated as 3. The storage requirements are shown below.

1. Recommended storage condition: the temperature should be 23 ± 5 °C and the relative humidity should be 35–60 %.
2. Shelf life (in a vacuum-sealed packaging): 12 months in recommended storage condition. The module is managed on a first-in, first-out basis.
3. Floor life: 168 hours ⁷ in a factory where the temperature is 23 ± 5 °C and relative humidity is below 60 %. After the vacuum-sealed packaging is removed, the module must be processed in reflow soldering or other high-temperature operations within 168 hours, and if the relative humidity is above 60 %, it is recommended to store the module for only 24 hours, so as to avoid the module being placed in the air for a long time and getting damp, which will affect the soldering quality. Otherwise, the module should be stored in an environment where the relative humidity is less than 10 % (e.g., a dry cabinet) or requires vacuum-sealed packaging again.
4. The module should be pre-baked to avoid blistering, cracks and inner-layer separation in PCB under the following circumstances:
 - The module is not stored in recommended storage condition;
 - Violation of the third requirement mentioned above;
 - Vacuum-sealed packaging is broken, or the packaging has been removed for over 24 hours;
 - Before module repairing.
5. If needed, the pre-baking should follow the requirements below:
 - The module should be baked for 24 hours at 120 ± 5 °C;
 - The module must be soldered to PCB within 24 hours after the baking, otherwise it should be

⁷ This floor life is only applicable when the environment conforms to *IPC/JEDEC J-STD-033*. It is recommended to start the solder reflow process within 24 hours after the package is removed if the temperature and moisture do not conform to, or are not sure to conform to *IPC/JEDEC J-STD-033*. Do not unpack the modules in large quantities until they are ready for soldering.

put in a dry environment such as in a dry cabinet.

NOTE

1. To avoid blistering, layer separation and other soldering issues, extended exposure of the module to the air is forbidden.
2. Take out the module from the package and put it on high-temperature-resistant fixtures before baking. If shorter baking time is desired, see *IPC/JEDEC J-STD-033* for the baking procedure.
3. Pay attention to ESD protection, such as wearing anti-static gloves, when touching the module.

8.2. Manufacturing and Soldering

Since CC200A-LB is a two-piece module, the cover will be warped during the second SMT process. The current reflow soldering thermal profile is modified as follows based on that of smart modules. For more details, see **document [4]**.

Push the squeegee to apply the solder paste on the surface of stencil, thus making the paste fill the stencil openings and then penetrate to the PCB. Apply proper force on the squeegee to produce a clean stencil surface on a single pass. To guarantee module soldering quality, the thickness of stencil for the module is recommended to be 0.15–0.2 mm. For more details, see **document [4]**.

The recommended peak reflow temperature should be 235–246 °C, with 246 °C as the absolute maximum reflow temperature. To avoid damage to the module caused by repeated heating, it is suggested that the module should be mounted only after reflow soldering for the other side of PCB has been completed. The recommended reflow soldering thermal profile (lead-free reflow soldering) and related parameters are shown below:

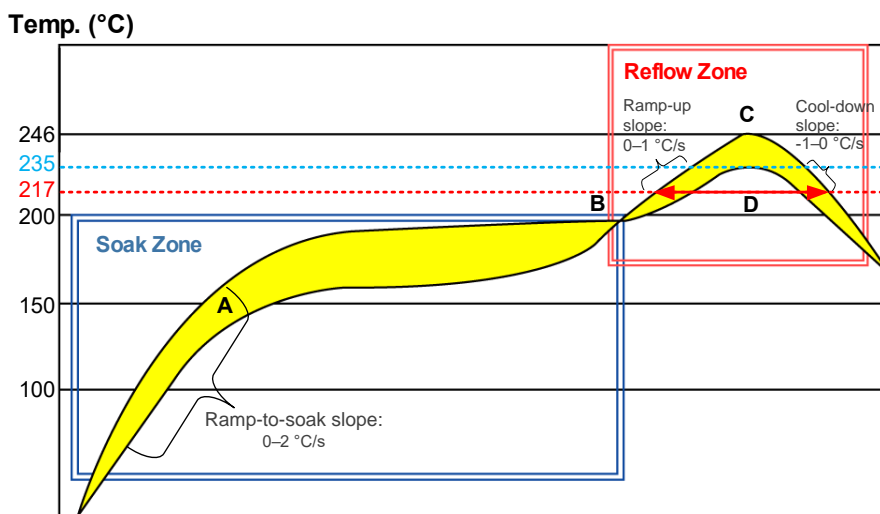

Figure 32: Recommended Reflow Soldering Thermal Profile

Table 33: Recommended Thermal Profile Parameters

Factor	Recommended Value
Soak Zone	
Ramp-to-soak slope	0–2 °C/s
Soak time (between A and B: 150 °C and 200 °C)	70–120 s
Reflow Zone	
217–235 °C ramp-up slope	0–1 °C/s
Reflow time (D: over 217°C)	40–65 s
Max temperature	235–246 °C
235–217 °C cool-down slope	-1–0 °C/s
Reflow Cycle	
Max reflow cycle	1

NOTE

1. The above profile parameter requirements are for the measured temperature of the solder joints. Both the hottest and coldest spots of solder joints on the PCB should meet the above requirements.
2. Due to the large-size form factor, to avoid excessive temperature change, which may cause excessive thermal deformation of the metal shielding frame and cover, it is recommended to reduce the ramp-up and cool-down slopes in the liquid phase of the solder paste. If possible, please choose a reflow oven with more than 10 temperature zones during production so that there are more temperature zones to set up to meet the optimal temperature curve.
3. If a conformal coating is necessary for the module, do not use any coating material that may chemically react with the PCB or shielding cover, and prevent the coating material from flowing into the module.
4. Avoid using ultrasonic technology for module cleaning since it can damage crystals inside the module.
5. Due to the complexity of the SMT process, contact Quectel Technical Support in advance for any situation that you are not sure about, or any process (e.g. selective wave soldering, ultrasonic soldering) that is not mentioned in **document [4]**.

8.3. Packaging Specification

This chapter describes only the key parameters and process of packaging. All figures below are for reference only. The appearance and structure of the packaging materials are subject to the actual delivery.

The module adopts carrier tape packaging and details are as follow:

8.3.1. Carrier Tape

Dimension details are as follow:

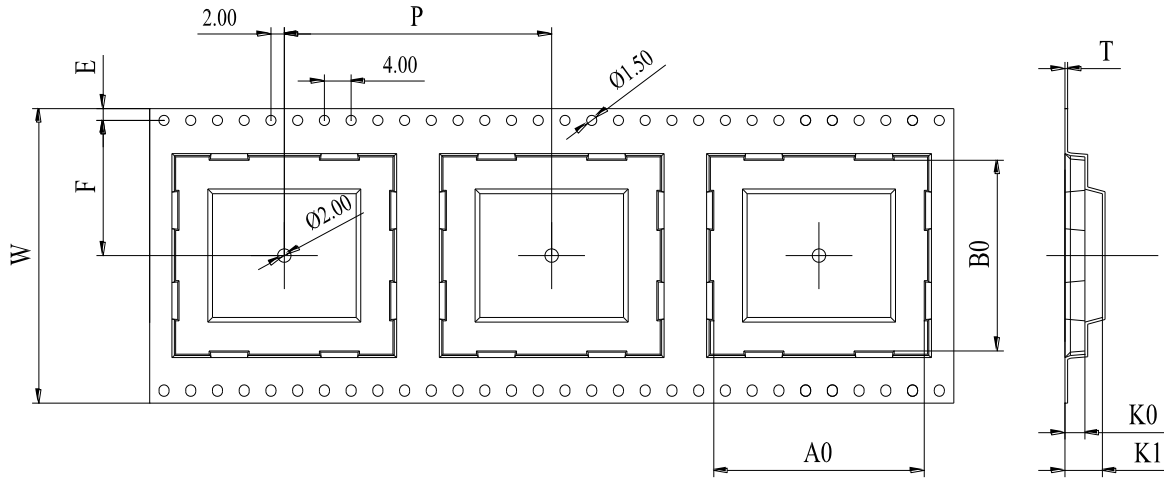

Figure 33: Carrier Tape Dimension Drawing

Table 34: Carrier Tape Dimension Table (Unit: mm)

W	P	T	A0	B0	K0	K1	F	E
56	48	0.4	38.5	37.5	4.6	5.6	26.2	1.75

8.3.2. Plastic Reel

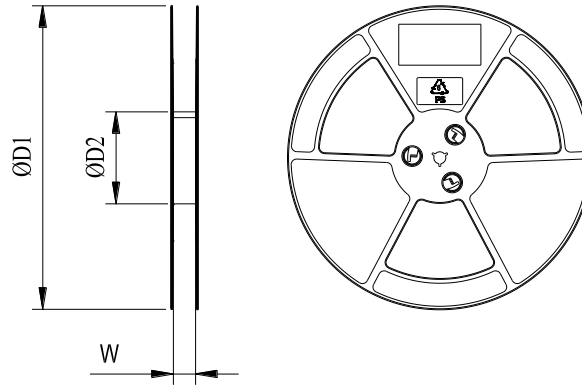

Figure 34: Plastic Reel Dimension Drawing

Table 35: Plastic Reel Dimension Table (Unit: mm)

ØD1	ØD2	W
330	100	56.5

8.3.3. Mounting Direction

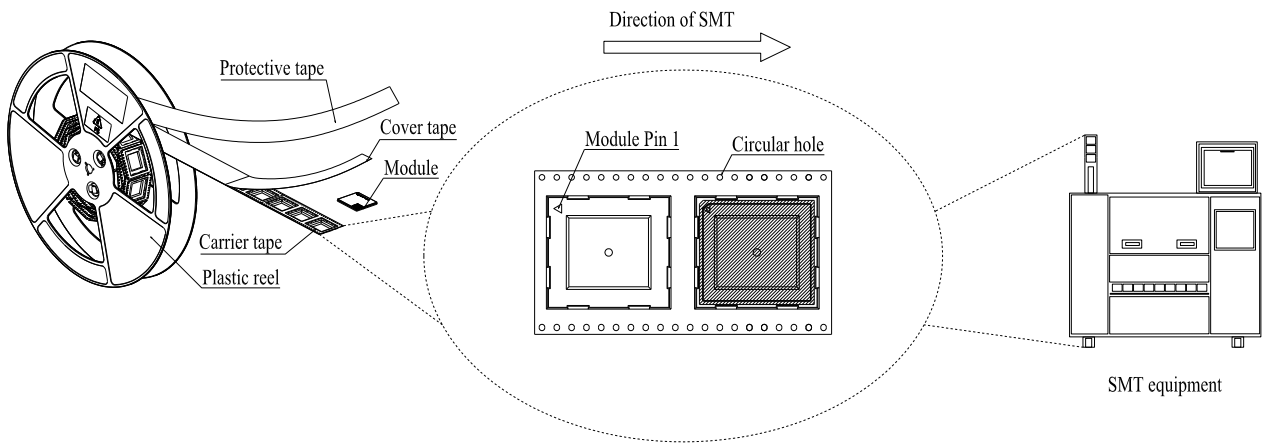
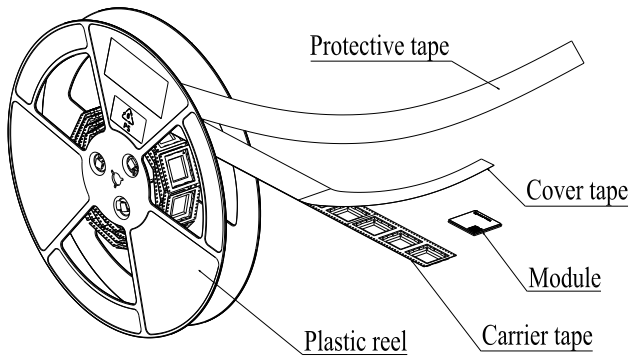

Figure 35: Mounting Direction

8.3.4. Packaging Process



Place the module into the carrier tape and use the cover tape to cover it; then wind the heat-sealed carrier tape to the plastic reel and use the protective tape for protection. 1 plastic reel can load 200 modules.

Place the packaged plastic reel, 1 humidity indicator card and 1 desiccant bag into a vacuum bag, vacuumize it.

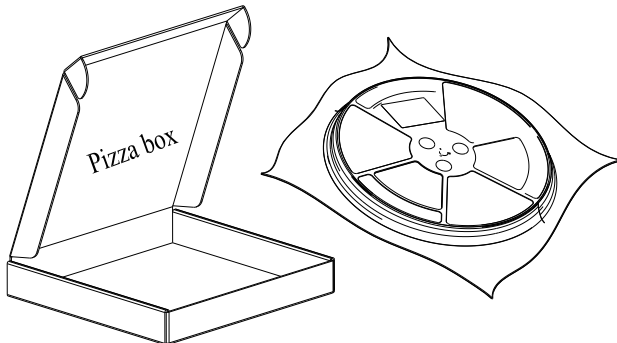
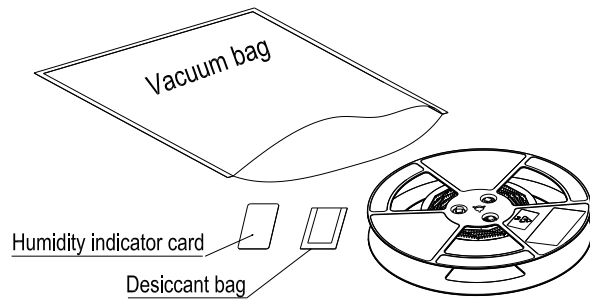

Place the vacuum-packed plastic reel into the pizza box.

Put 4 packaged pizza boxes into 1 carton box and seal it. 1 carton box can pack 800 modules.

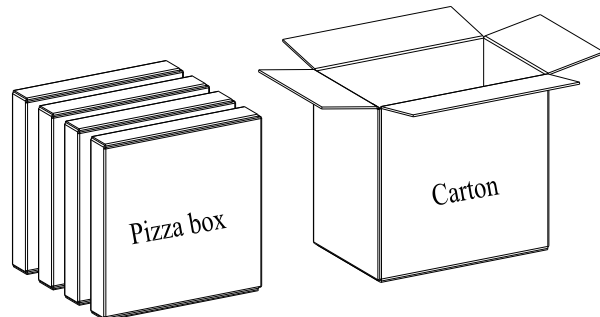

Figure 36: Packaging Process

9 Appendix References

Table 36: Related Documents

Document Name
[1] Quectel_SAT-A_EVB_User_Guide
[2] Quectel_CC200A-LB_Operating_Mode_Application_Note
[3] Quectel_RF_Layout_Application_Note
[4] Quectel_Module_SMT_Application_Note
[5] Quectel_CC200A-LB_AT_Commands_Manual

Table 37: Terms and Abbreviations

Abbreviation	Description
ADC	Analog-to-Digital Converter
AGNSS	Assisted GNSS (Global Navigation Satellite System)
BDS	BeiDou Navigation Satellite System
bps	Bits Per Second
C/No	Carrier-to-noise Ratio
EASY	Embedded Assist System
EPO	Extended Prediction Orbit
ESD	Electrostatic Discharge
PMOS	Positive channel MOSFET
GNSS	Global Navigation Satellite System
GPS	Global Positioning System

GLONASS	Global Navigation Satellite System (Russia)
Galileo	Galileo Satellite Navigation System (EU)
IC	Integrated Circuit
I2C	Inter-Integrated Circuit
I/O	Input/Output
Inom	Nominal Current
LED	Light Emitting Diode
LGA	Land Grid Array
LNA	Low Noise Amplifier
MCU	Microcontroller Unit
PA	Power Amplifier
PCB	Printed Circuit Board
RAM	Random Access Memory
RF	Radio Frequency
Rx	Receive
Tx	Transmit
UART	Universal Asynchronous Receiver Transmitter
VBAT	Voltage at Battery (Pin)
Vmax	Maximum Voltage
Vnom	Nominal Voltage
Vmin	Minimum Voltage
V _{IH} max	Maximum High-level Input Voltage
V _{IH} min	Minimum High-level Input Voltage
V _{IL} max	Maximum Low-level Input Voltage
V _{IL} min	Minimum Low-level Input Voltage

$V_{I\max}$	Absolute Maximum Input Voltage
$V_{I\min}$	Absolute Minimum Input Voltage
$V_{OH\max}$	Maximum High-level Output Voltage
$V_{OH\min}$	Minimum High-level Output Voltage
$V_{OL\max}$	Maximum Low-level Output Voltage
$V_{OL\min}$	Minimum Low-level Output Voltage

OEM/Integrators Installation Manual

Important Notice to OEM integrators 1. This module is limited to OEM installation ONLY. 2. This module is limited to installation in mobile or fixed applications, according to Part 2.1091(b). 3. The separate approval is required for all other operating configurations, including portable configurations with respect to Part 2.1093 and different antenna configurations 4. For FCC Part 15.31 (h) and (k): The host manufacturer is responsible for additional testing to verify compliance as a composite system. When testing the host device for compliance with Part 15 Subpart B, the host manufacturer is required to show compliance with Part 15 Subpart B while the transmitter module(s) are installed and operating. The modules should be transmitting and the evaluation should confirm that the module's intentional emissions are compliant (i.e. fundamental and out of band emissions). The host manufacturer must verify that there are no additional unintentional emissions other than what is permitted in Part 15 Subpart B or emissions are complaint with the transmitter(s) rule(s). The Grantee will provide guidance to the host manufacturer for Part 15 B requirements if needed.

Important Note

notice that any deviation(s) from the defined parameters of the antenna trace, as described by the instructions, require that the host product manufacturer must notify to Quectel that they wish to change the antenna trace design. In this case, a Class II permissive change application is required to be filed by the USI, or the host manufacturer can take responsibility through the change in FCC ID (new application) procedure followed by a Class II permissive change application

End Product Labeling

When the module is installed in the host device, the FCC ID label must be visible through a window on the final device or it must be visible when an access panel, door or cover is easily re-moved. If not, a second label must be placed on the outside of the final device that contains the following text: "Contains FCC ID: XMR2023CC200ALB" "Contains IC: 10224A-023CC200ALB". The FCC ID/IC ID can be used only when all FCC/IC compliance requirements are met.

Antenna

- (1) The antenna must be installed such that 20 cm is maintained between the antenna and users,
- (2) The transmitter module may not be co-located with any other transmitter or antenna.

In the event that these conditions cannot be met (for example certain laptop configurations or co-location with another transmitter), then the FCC/IC authorization is no longer considered valid and the FCC ID/IC ID cannot be used on the final product. In these circumstances, the OEM integrator will be responsible for re-evaluating the end product (including the transmitter) and obtaining a separate FCC/IC authorization.

To comply with FCC regulations limiting both maximum RF output power and human exposure to RF radiation, maximum antenna gain (including cable loss) must not exceed

Manual Information to the End User

The OEM integrator has to be aware not to provide information to the end user regarding how to install or remove this RF module in the user's manual of the end product which integrates this module. The end user manual shall include all required regulatory information/warning as show in this manual

Federal Communication Commission Interference Statement

This device complies with Part 15 of the FCC Rules. Operation is subject to the following two conditions: (1) This device may not cause harmful interference, and (2) this device must accept any interference received, including interference that may cause undesired operation.

This equipment has been tested and found to comply with the limits for a Class B digital device, pursuant to Part 15 of the FCC Rules. These limits are designed to provide reasonable protection against harmful interference in a residential installation. This equipment generates, uses and can radiate radio frequency energy and, if not installed and used in accordance with the instructions, may cause harmful interference to radio communications. However, there is no guarantee that interference will not occur in a particular installation. If this equipment does cause harmful interference to radio or television reception, which can be determined by turning the equipment off and on, the user is encouraged to try to correct the interference by one of the following measures:

- Reorient or relocate the receiving antenna.
- Increase the separation between the equipment and receiver
- Connect the equipment into an outlet on a circuit different from that to which the receiver is connected.
- Consult the dealer or an experienced radio/TV technician for help.

Any changes or modifications not expressly approved by the party responsible for compliance could void the user's authority to operate this equipment. This transmitter must not be co-located or operating in conjunction with any other antenna or transmitter.

List of applicable FCC rules

This module has been tested and found to comply with part 25 requirements for Modular Approval. The modular transmitter is only FCC authorized for the specific rule parts (i.e., FCC transmitter rules) listed on the grant, and that the host product manufacturer is responsible for compliance to any other FCC rules that apply to the host not covered by the modular transmitter grant of certification. If the grantee markets their product as being Part 15 Subpart B compliant (when it also contains unintentional-radiator digital circuitry), then the grantee shall provide a notice stating that the final host product still requires Part 15 Subpart B compliance testing with the modular transmitter installed.

This device is intended only for OEM integrators under the following conditions: (For module device use)

- 1) The antenna must be installed such that 20 cm is maintained between the antenna and users,
and
- 2) The transmitter module may not be co-located with any other transmitter or antenna.

As long as 2 conditions above are met, further transmitter test will not be required. However, the OEM integrator is still responsible for testing their end-product for any additional compliance requirements required with this module installed.

Radiation Exposure Statement

This equipment complies with FCC radiation exposure limits set forth for an uncontrolled environment. This equipment should be installed and operated with minimum distance 20 cm between the radiator & your body.

Industry Canada Statement

This device complies with Industry Canada's licence-exempt RSSs. Operation is subject to the following two conditions:

- (1) This device may not cause interference; and
- (2) This device must accept any interference, including interference that may cause undesired operation of the device.

Le présent appareil est conforme aux CNR d'Industrie Canada applicables aux appareils radio exempts de licence. L'exploitation est autorisée aux deux conditions suivantes:

- (1) l'appareil ne doit pas produire de brouillage, et
- (2) l'utilisateur de l'appareil doit accepter tout brouillage radioélectrique subi, même si le brouillage est susceptible d'en compromettre le fonctionnement."

Radiation Exposure Statement

This equipment complies with IC radiation exposure limits set forth for an uncontrolled environment. This equipment should be installed and operated with minimum distance 30 cm between the radiator & your body

Déclaration d'exposition aux radiations:

Cet équipement est conforme aux limites d'exposition aux rayonnements ISED établies pour un environnement non contrôlé. Cet équipement doit être installé et utilisé avec un minimum de 30 cm de distance entre la source de rayonnement et votre corps.

This device is intended only for OEM integrators under the following conditions: (For module device use)

- 1) The antenna must be installed such that 30 cm is maintained between the antenna and users, and
- 2) The transmitter module may not be co-located with any other transmitter or antenna. As long as 2 conditions above are met, further transmitter test will not be required. However, the OEM integrator is still responsible for testing their end-product for any additional compliance requirements required with this module installed.

Cet appareil est conçu uniquement pour les intégrateurs OEM dans les conditions suivantes: (Pour utilisation de dispositif module)

- 1) L'antenne doit être installée de telle sorte qu'une distance de 30 cm est respectée entre l'antenne et les utilisateurs, et
- 2) Le module émetteur peut ne pas être coïmplanté avec un autre émetteur ou antenne.

Tant que les 2 conditions ci-dessus sont remplies, des essais supplémentaires sur l'émetteur ne seront pas nécessaires. Toutefois, l'intégrateur OEM est toujours responsable des essais sur son produit final pour toutes exigences de conformité supplémentaires requis pour ce module installé.

IMPORTANT NOTE:

In the event that these conditions cannot be met (for example certain laptop configurations or colocation with another transmitter), then the Canada authorization is no longer considered valid and the IC ID cannot be used on the final product. In these circumstances, the OEM integrator will be responsible for re-evaluating the end product (including the transmitter) and obtaining a separate Canada authorization.

NOTE IMPORTANTE:

Dans le cas où ces conditions ne peuvent être satisfaites (par exemple pour certaines configurations d'ordinateur portable ou de certaines co-localisation avec un autre émetteur), l'autorisation du Canada n'est plus considéré comme valide et l'ID IC ne peut pas être utilisé sur le produit final. Dans ces circonstances, l'intégrateur OEM sera chargé de réévaluer le produit final (y compris l'émetteur) et l'obtention d'une autorisation distincte au Canada.

End Product Labeling

This transmitter module is authorized only for use in device where the antenna may be installed such that 30 cm may be maintained between the antenna and users. The final end product must be labeled in a visible area with the following: "Contains IC: 10224A-023CC200ALB".

Plaque signalétique du produit final

Ce module émetteur est autorisé uniquement pour une utilisation dans un dispositif où l'antenne peut être installée de telle sorte qu'une distance de 30cm peut être maintenue entre l'antenne et les utilisateurs. Le produit final doit être étiqueté dans un endroit visible avec l'inscription suivante:

"Contient des IC: 10224A-023CC200ALB ".

Manual Information to the End User

The OEM integrator has to be aware not to provide information to the end user regarding how to install or remove this RF module in the user's manual of the end product which integrates this module.

The end user manual shall include all required regulatory information/warning as show in this manual.

Manuel d'information à l'utilisateur final

L'intégrateur OEM doit être conscient de ne pas fournir des informations à l'utilisateur final quant à la façon d'installer ou de supprimer ce module RF dans le manuel de l'utilisateur du produit final qui intègre ce module.

Le manuel de l'utilisateur final doit inclure toutes les informations réglementaires requises et avertissements comme indiqué dans ce manuel.