

PSD 802.11a 5825MHz Ant1

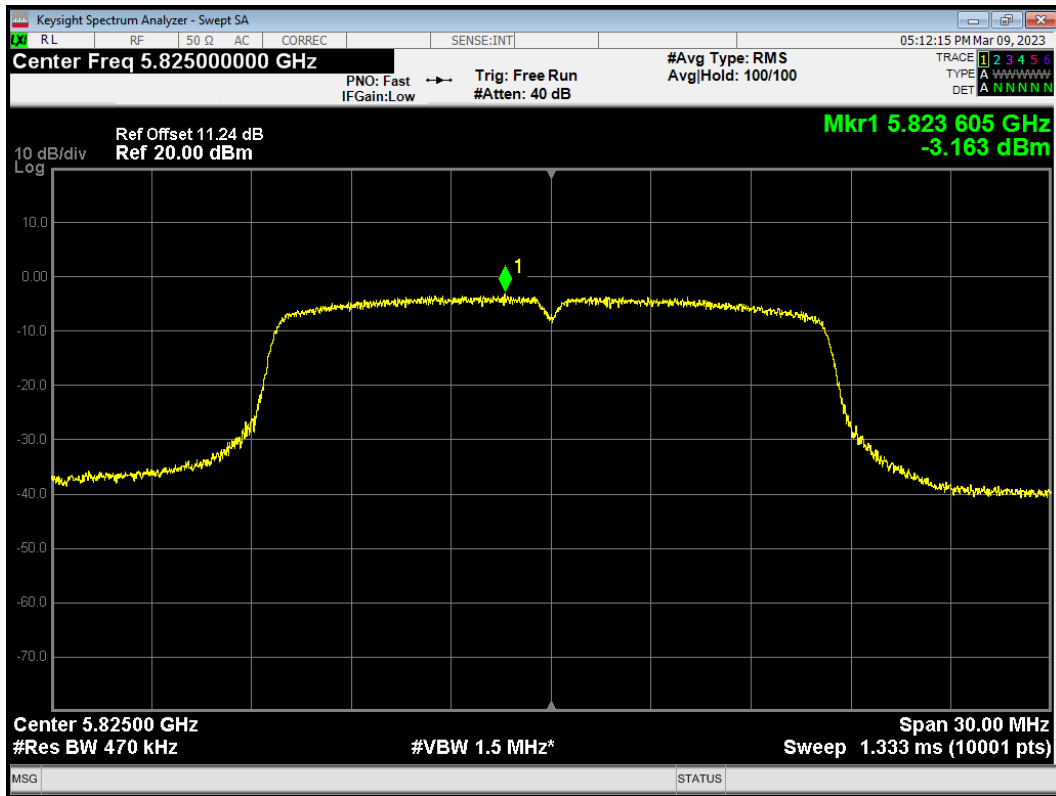

PSD 802.11a 5825MHz Ant2

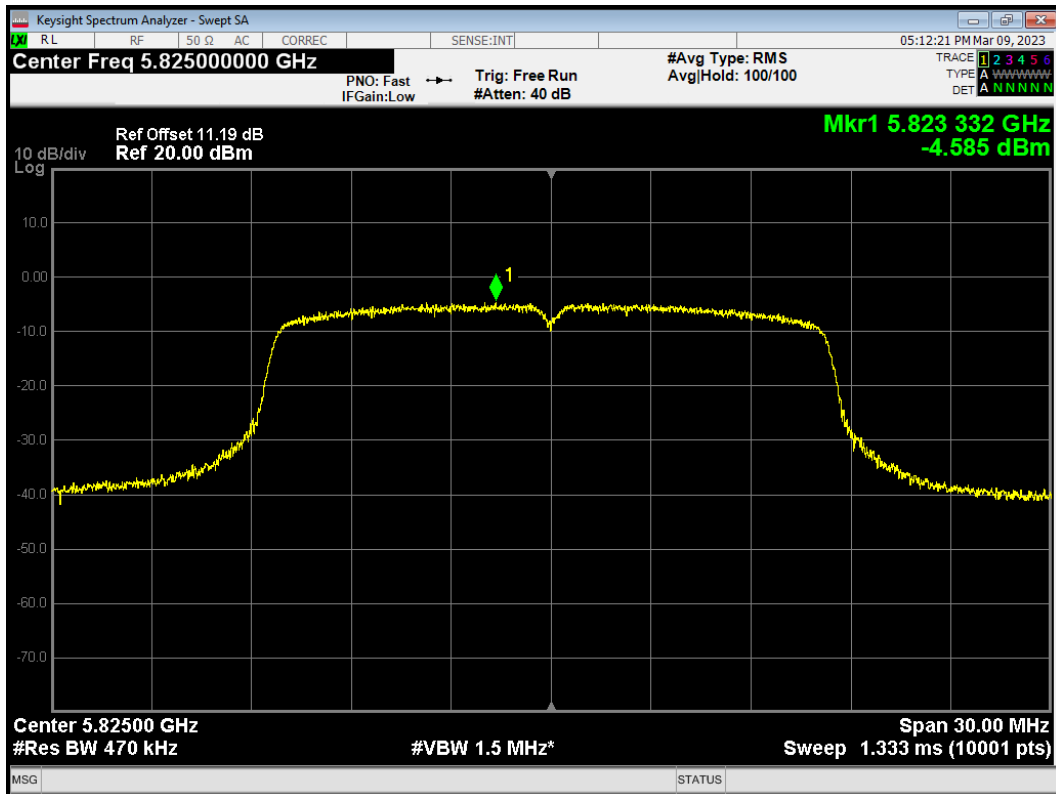

PSD 802.11ac (VHT20) 5720MHz Ant1

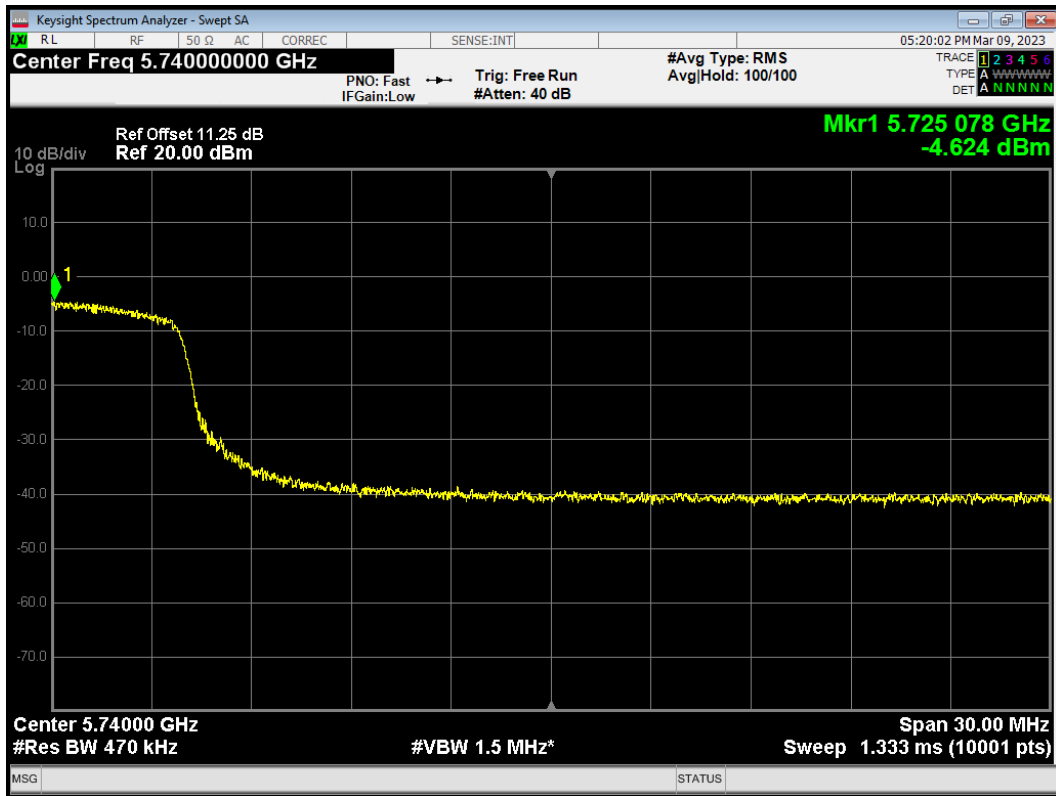

PSD 802.11ac (VHT20) 5720MHz Ant2

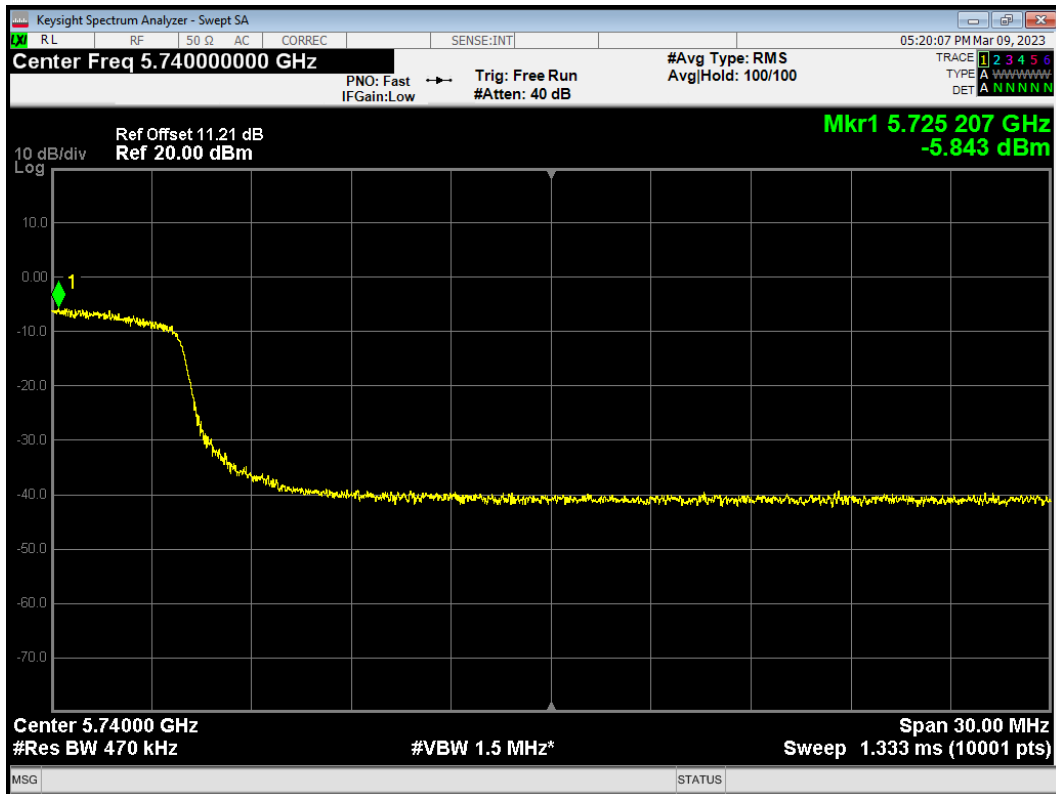

PSD 802.11ac (VHT20) 5745MHz Ant1

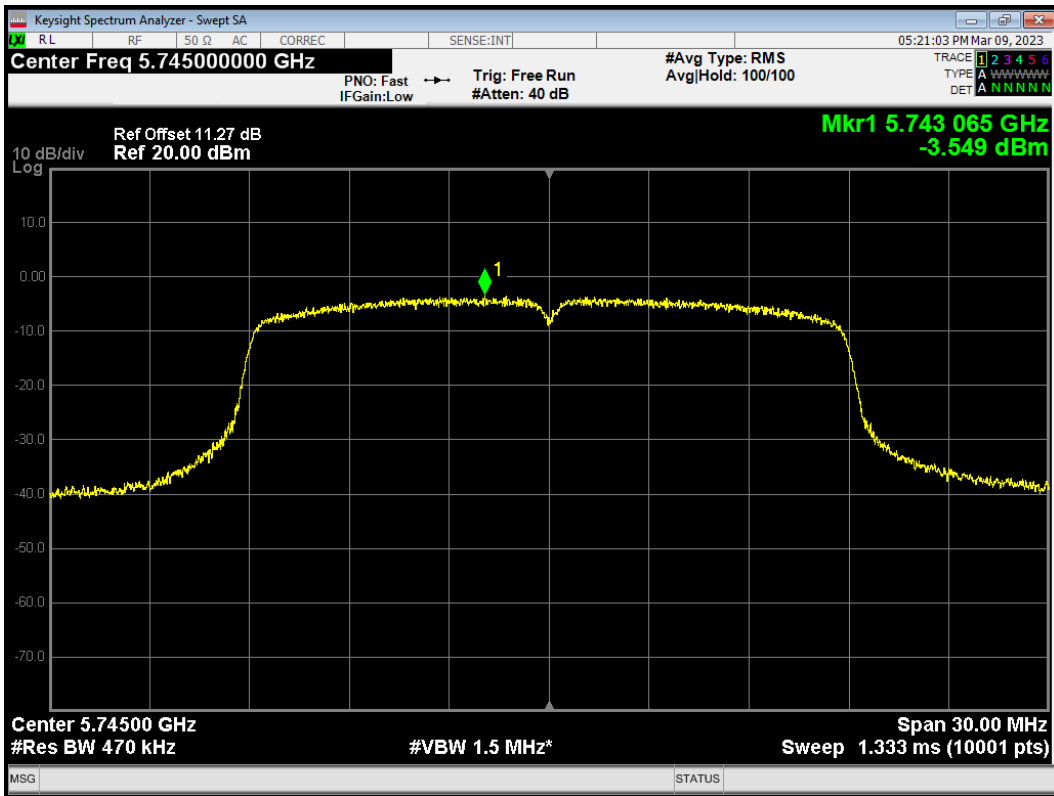

PSD 802.11ac (VHT20) 5745MHz Ant2

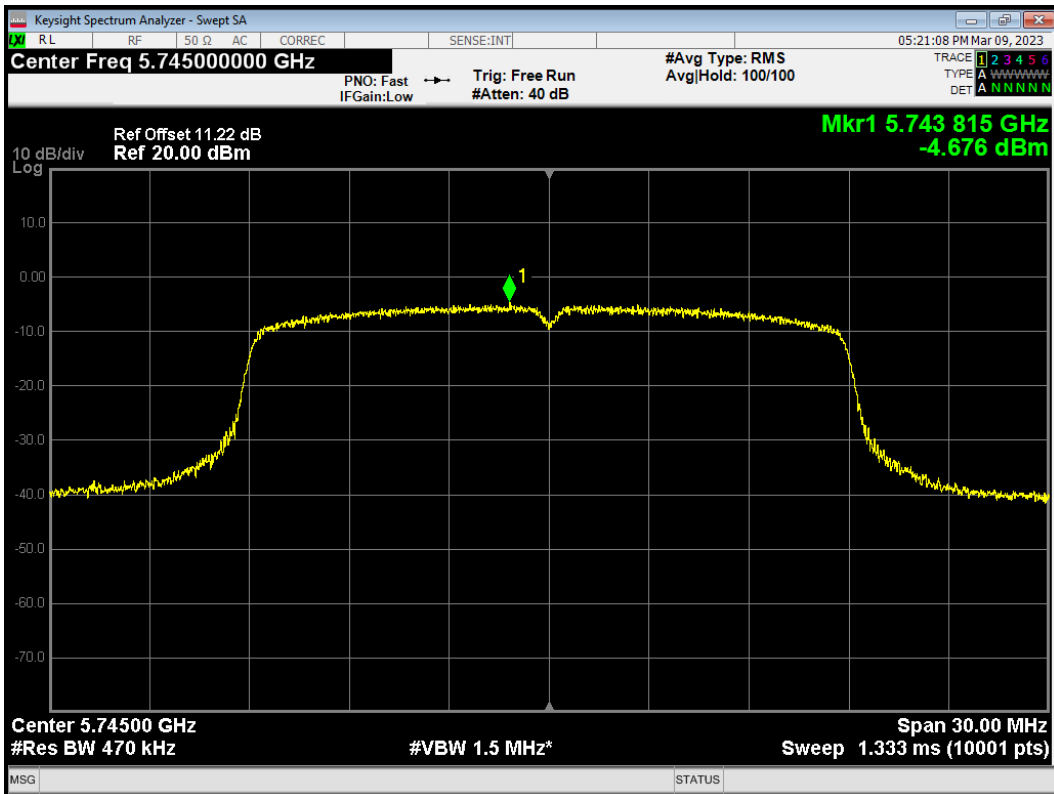

PSD 802.11ac (VHT20) 5785MHz Ant1

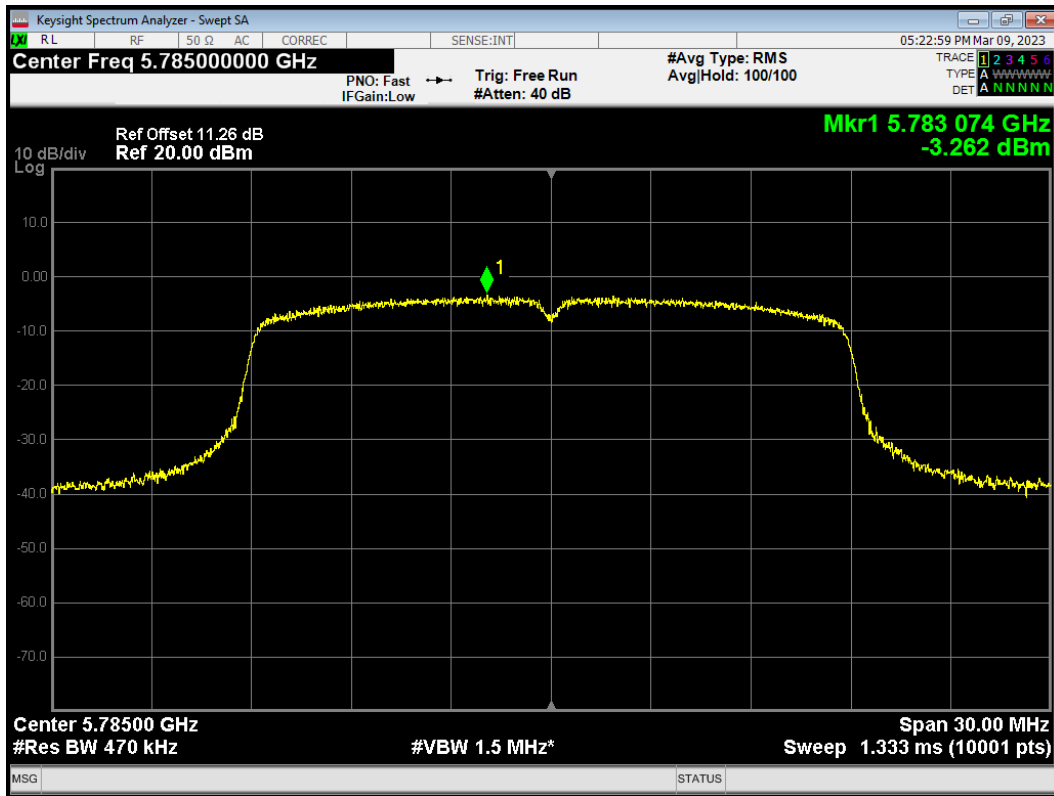

PSD 802.11ac (VHT20) 5785MHz Ant2

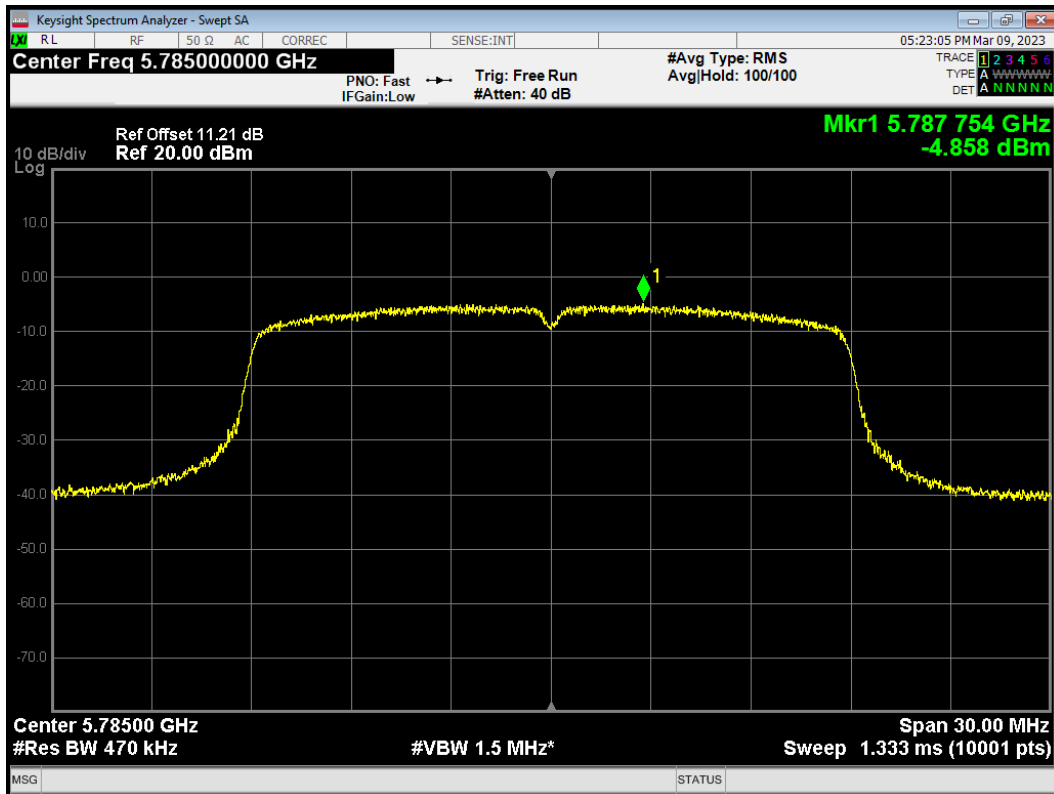

PSD 802.11ac (VHT20) 5825MHz Ant1

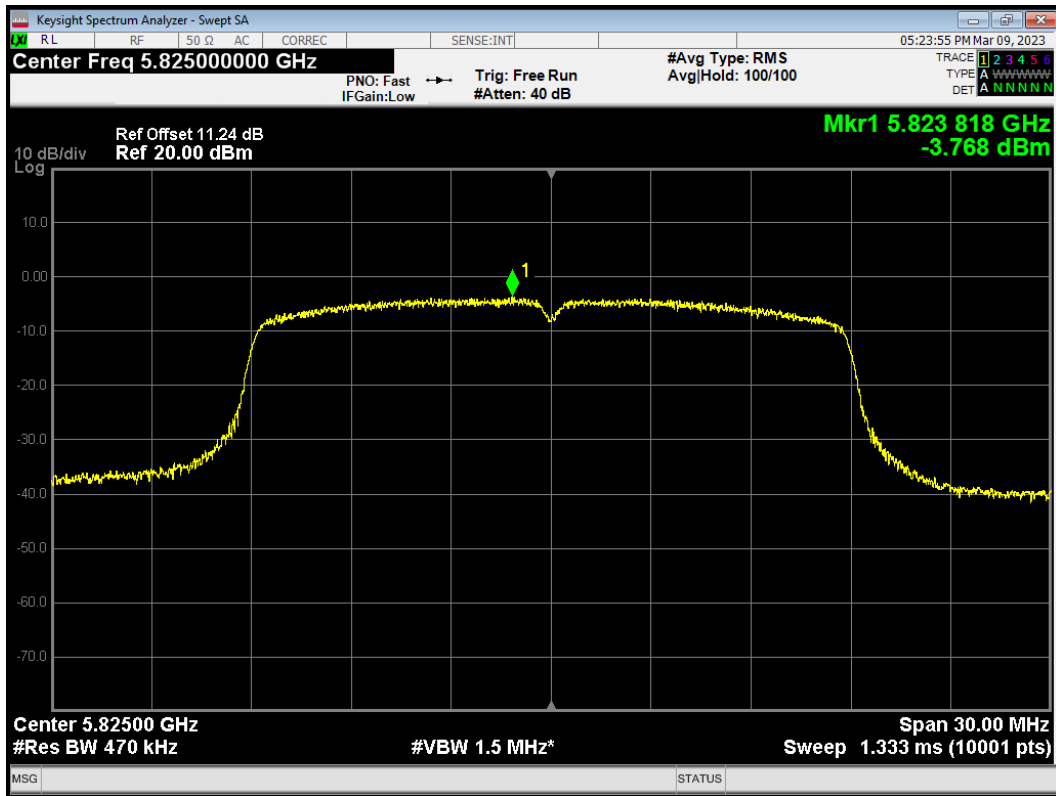

PSD 802.11ac (VHT20) 5825MHz Ant2

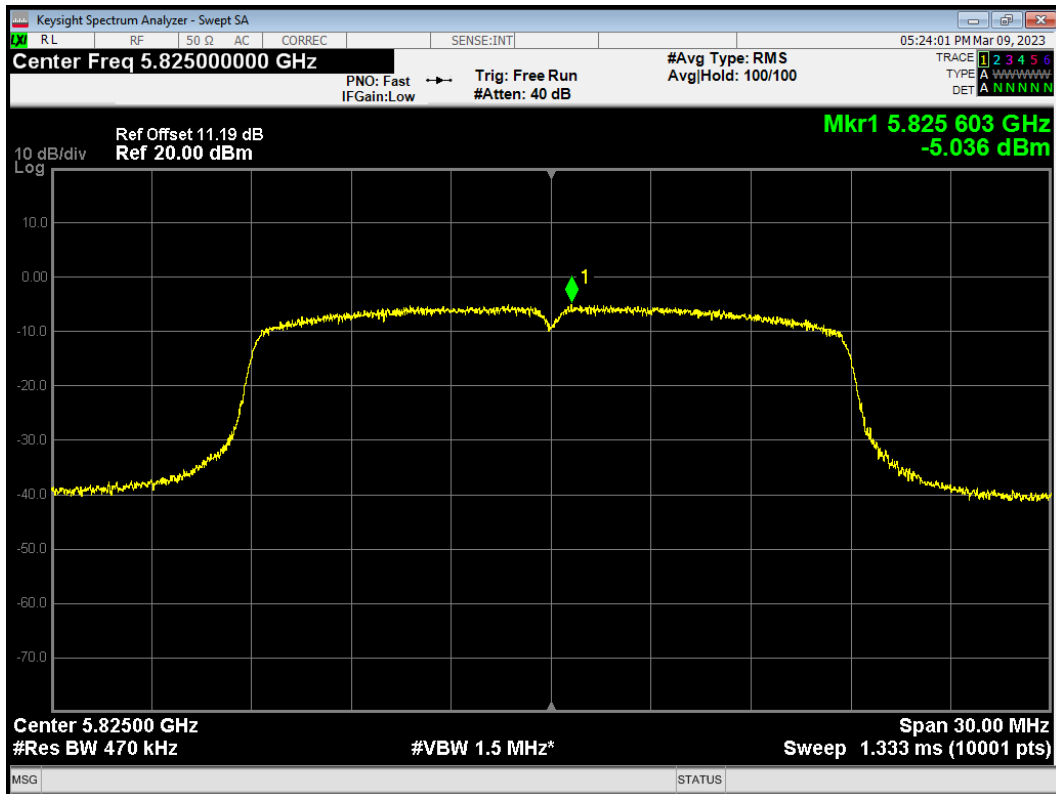

PSD 802.11ac (VHT40) 5710MHz Ant1

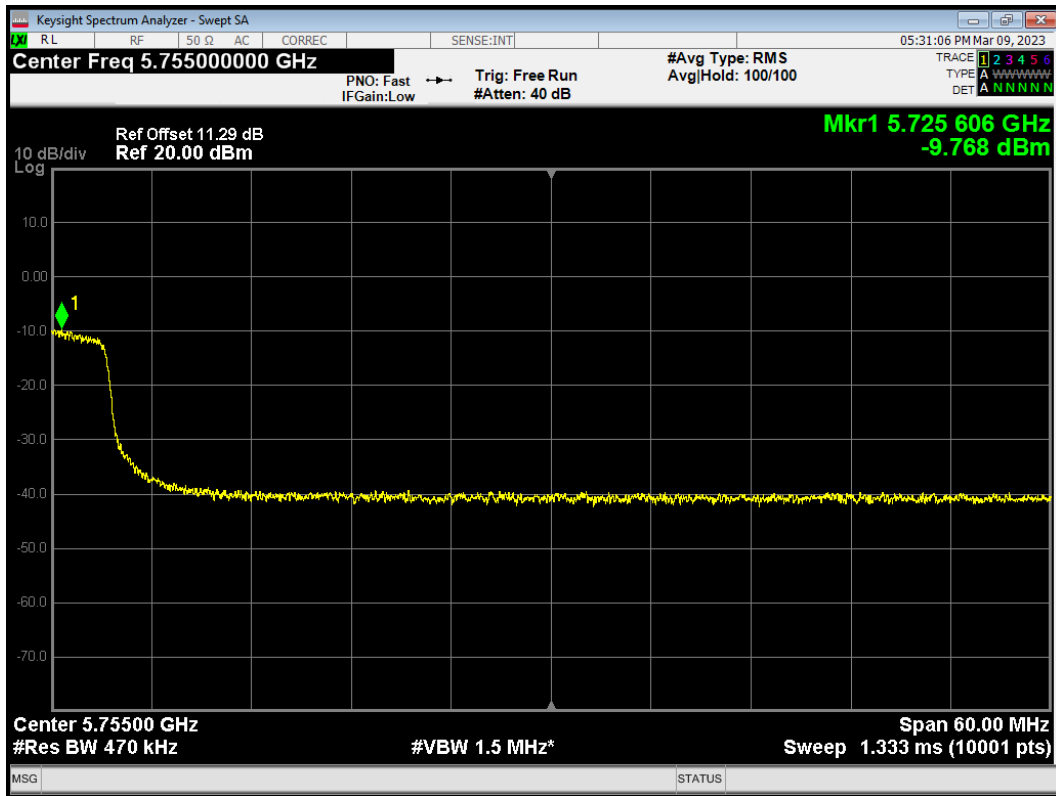

PSD 802.11ac (VHT40) 5710MHz Ant2

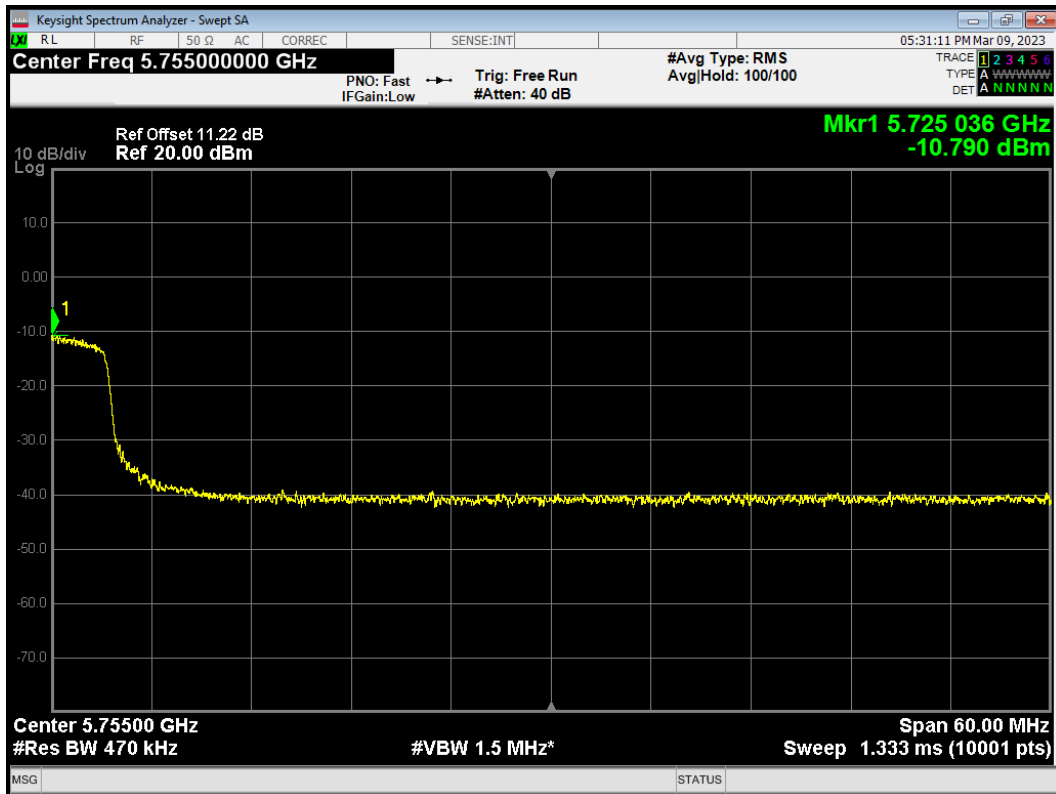

PSD 802.11ac (VHT40) 5755MHz Ant1

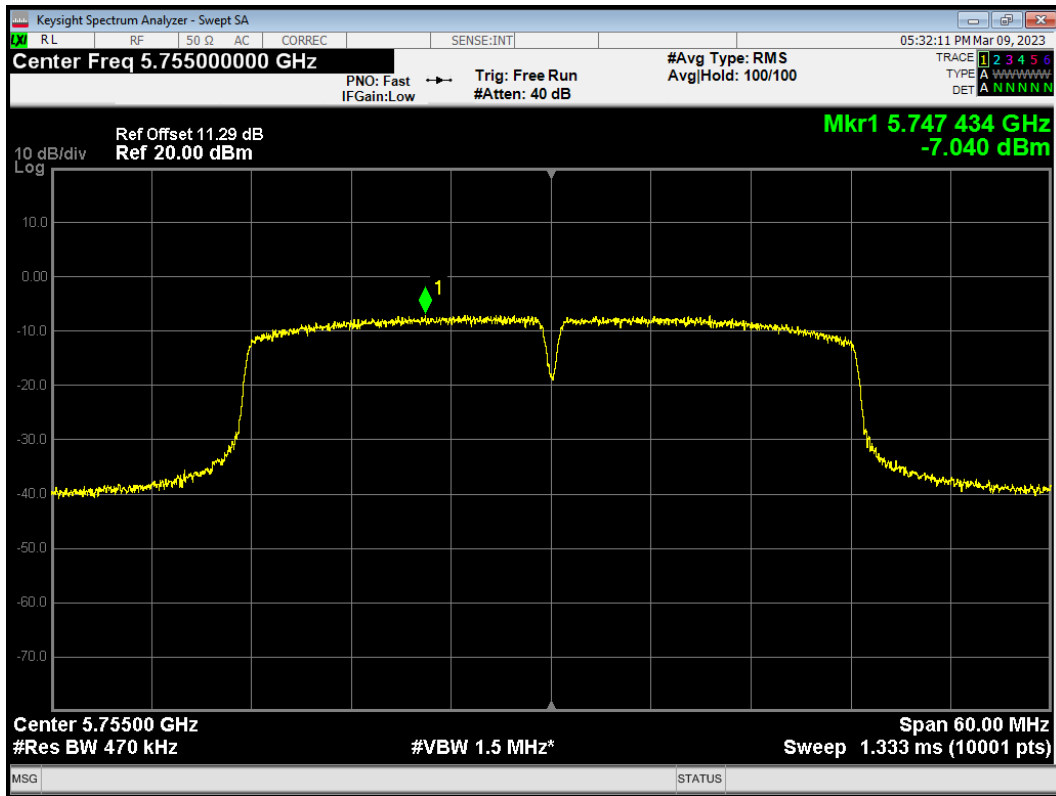

PSD 802.11ac (VHT40) 5755MHz Ant2

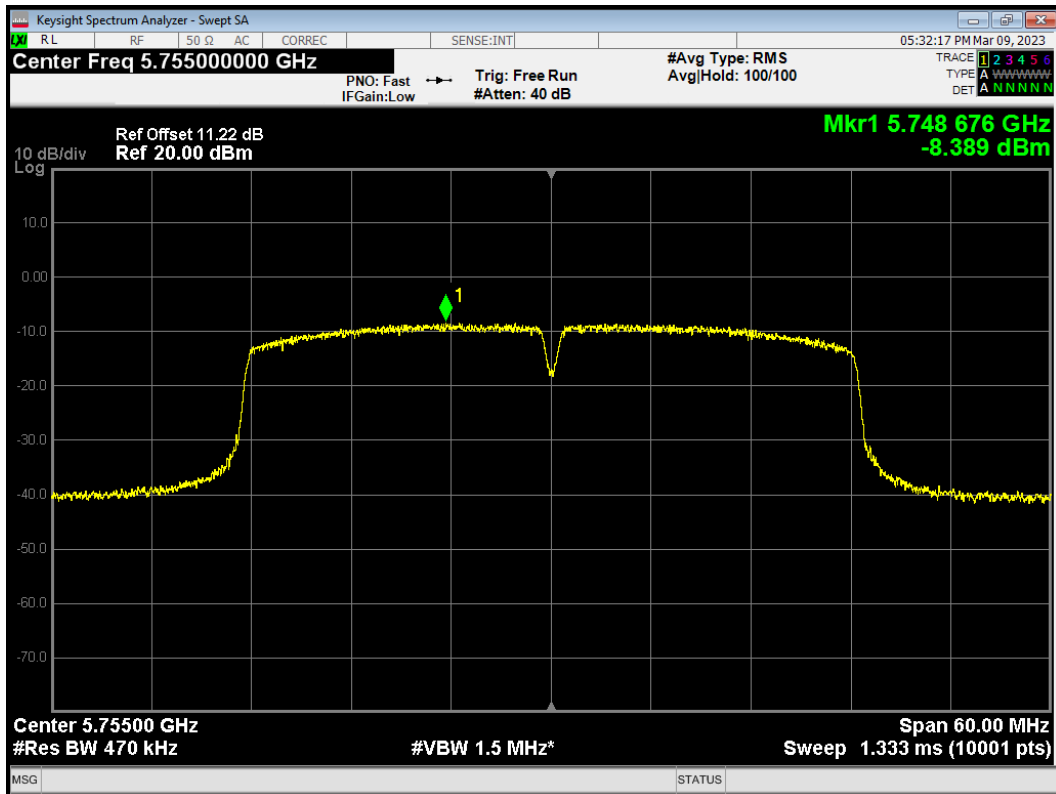

PSD 802.11ac (VHT40) 5795MHz Ant1

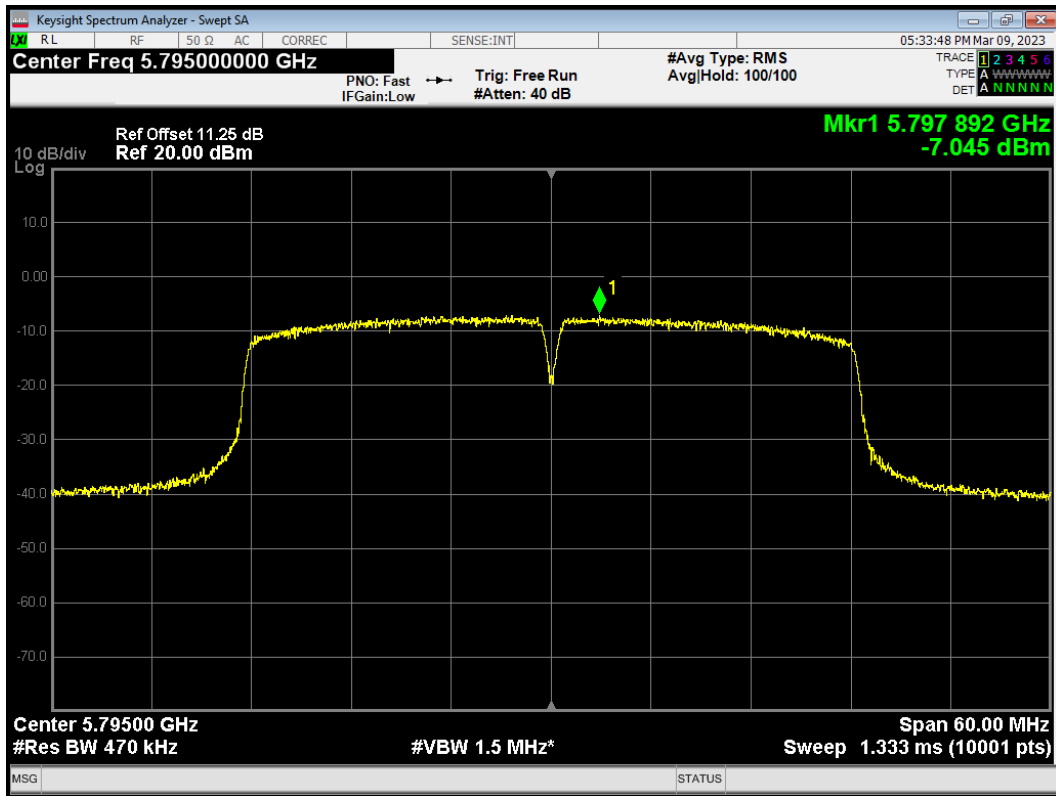

PSD 802.11ac (VHT40) 5795MHz Ant2

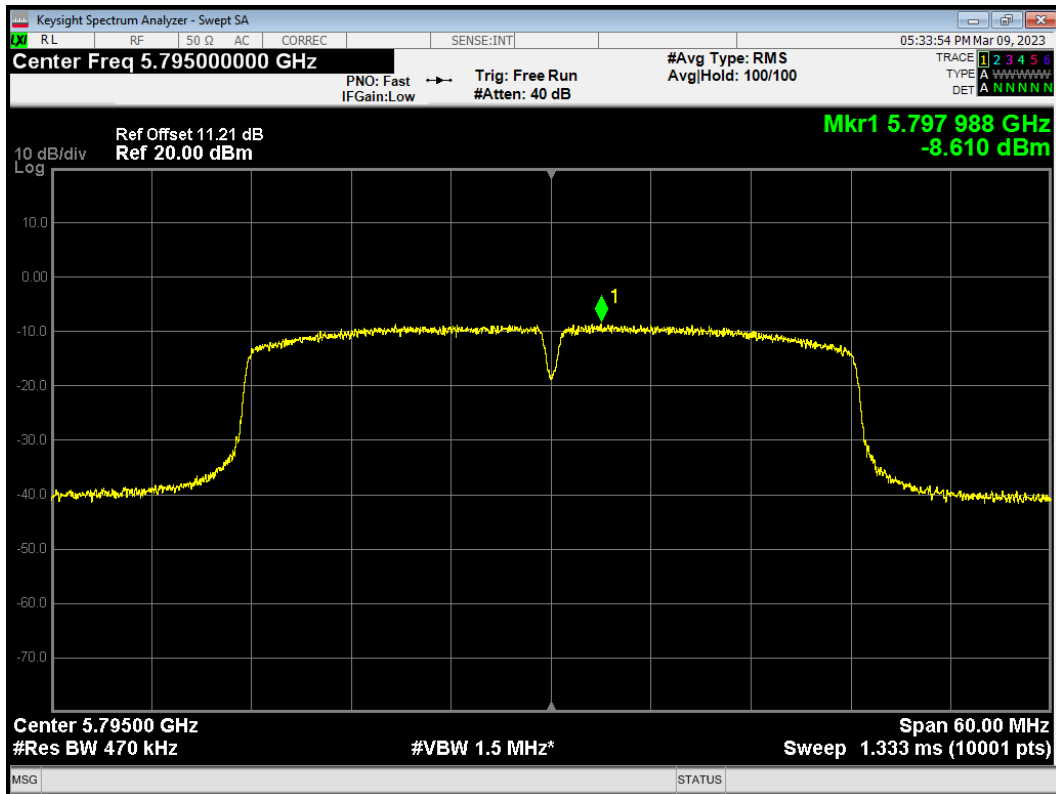

PSD 802.11ac (VHT80) 5690MHz Ant1

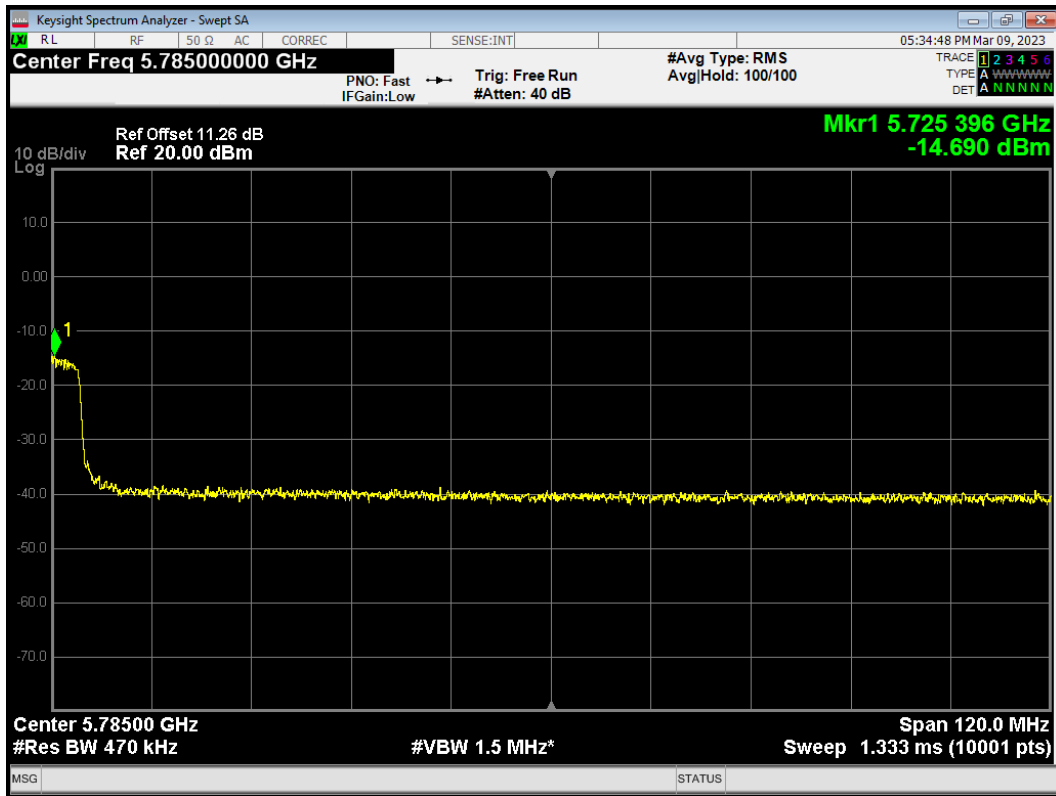

PSD 802.11ac (VHT80) 5690MHz Ant2

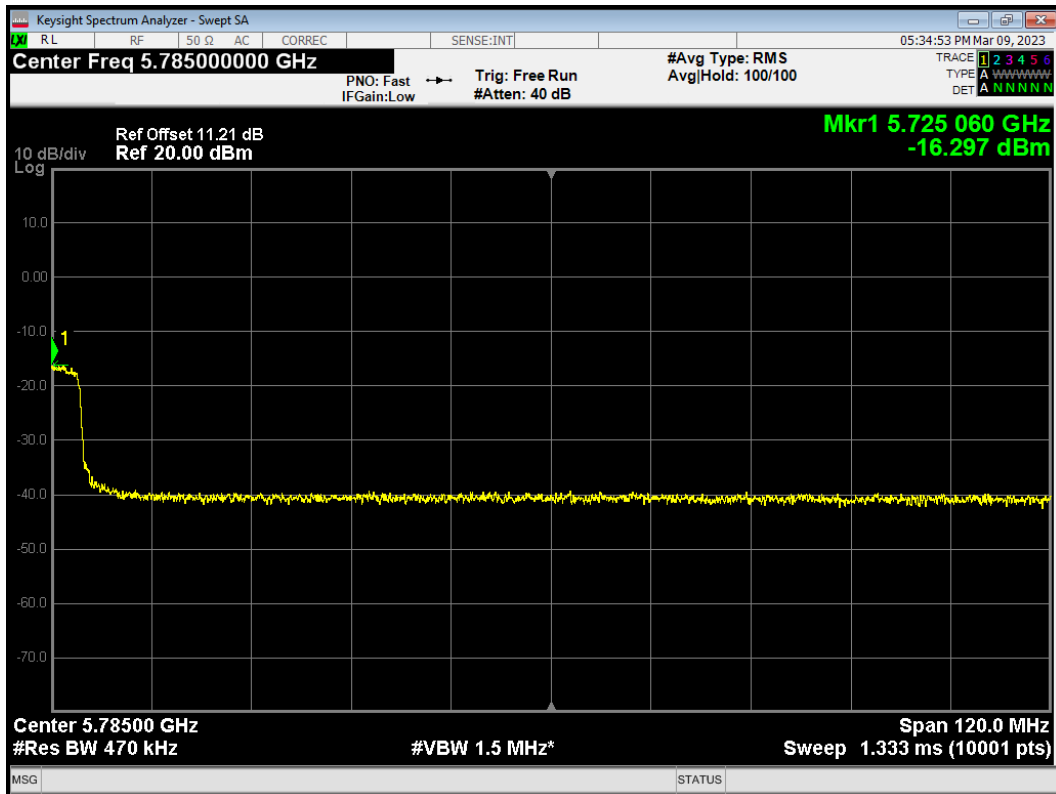

PSD 802.11ac (VHT80) 5775MHz Ant1

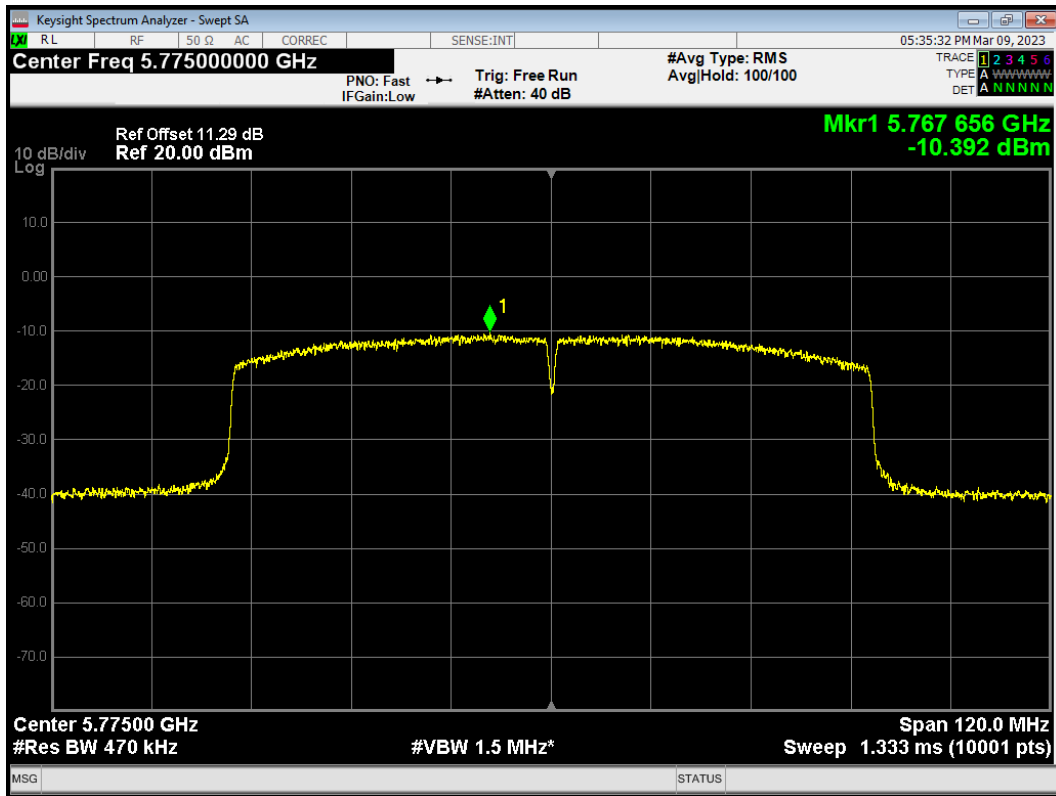

PSD 802.11ac (VHT80) 5775MHz Ant2

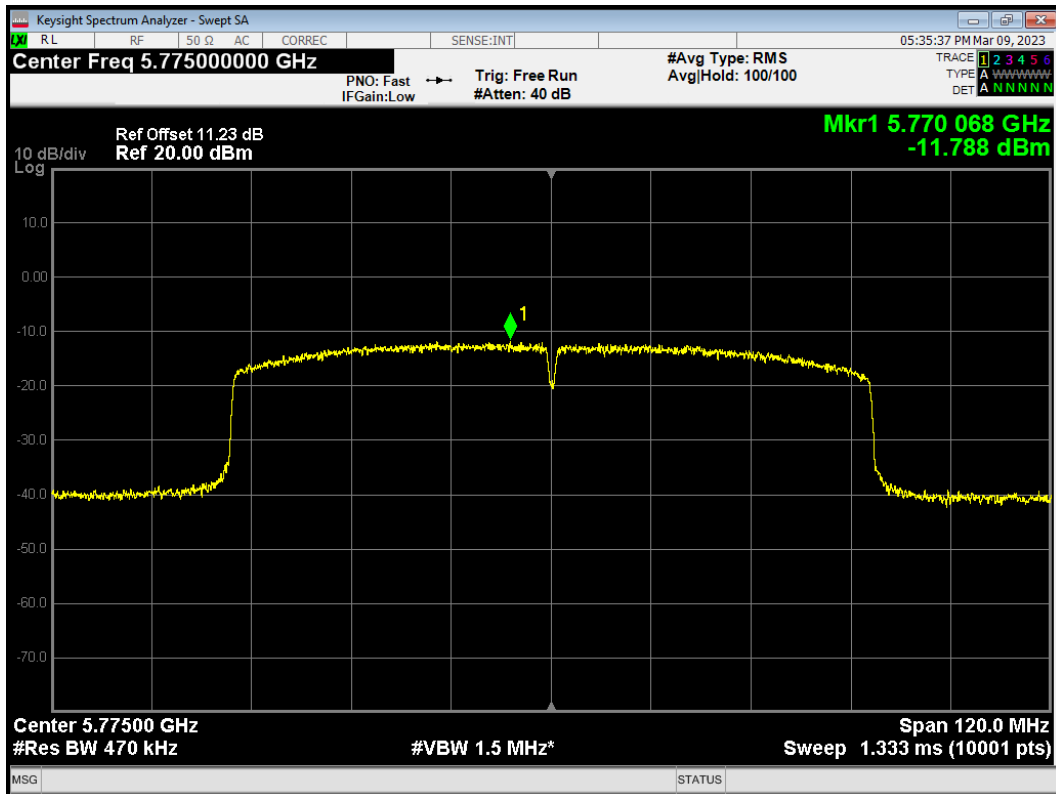

PSD 802.11n (HT20) 5720MHz Ant1

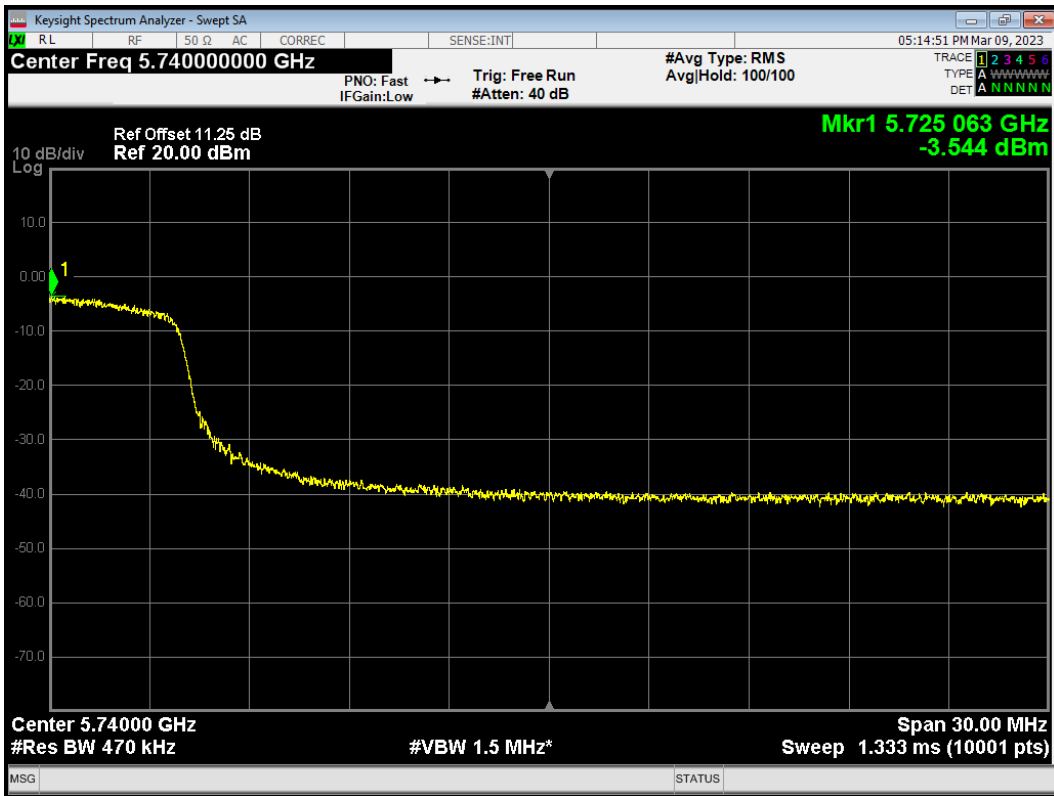

PSD 802.11n (HT20) 5720MHz Ant2

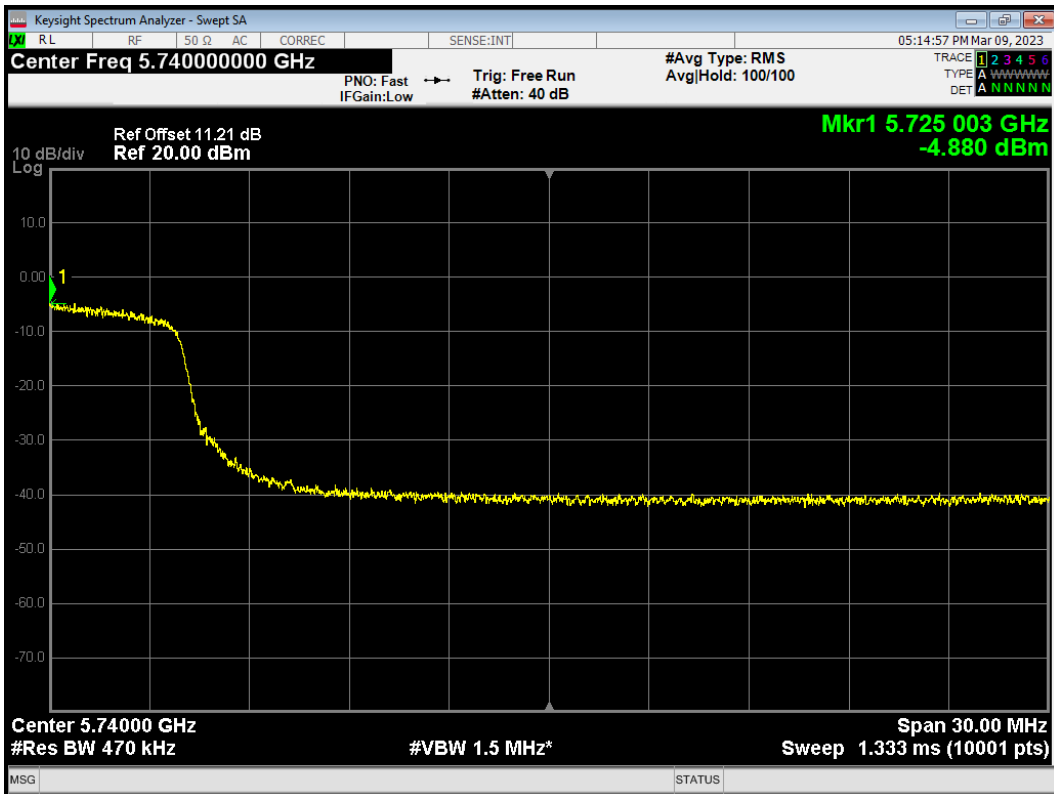

PSD 802.11n (HT20) 5745MHz Ant1

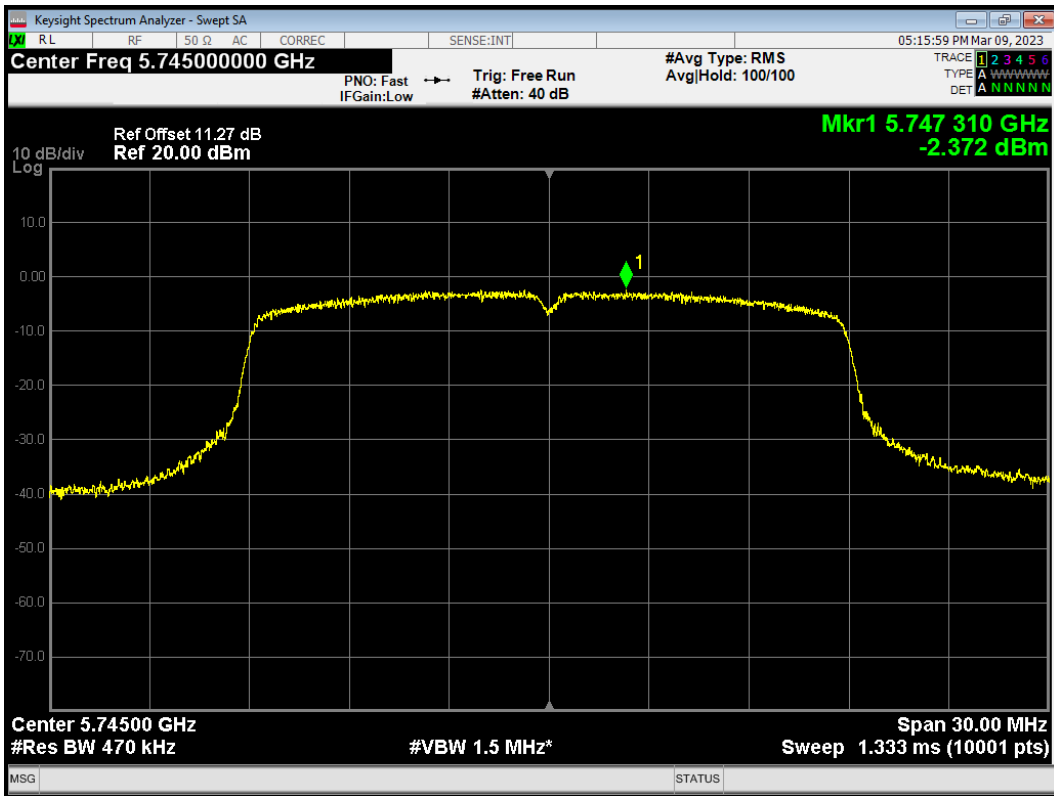

PSD 802.11n (HT20) 5745MHz Ant2

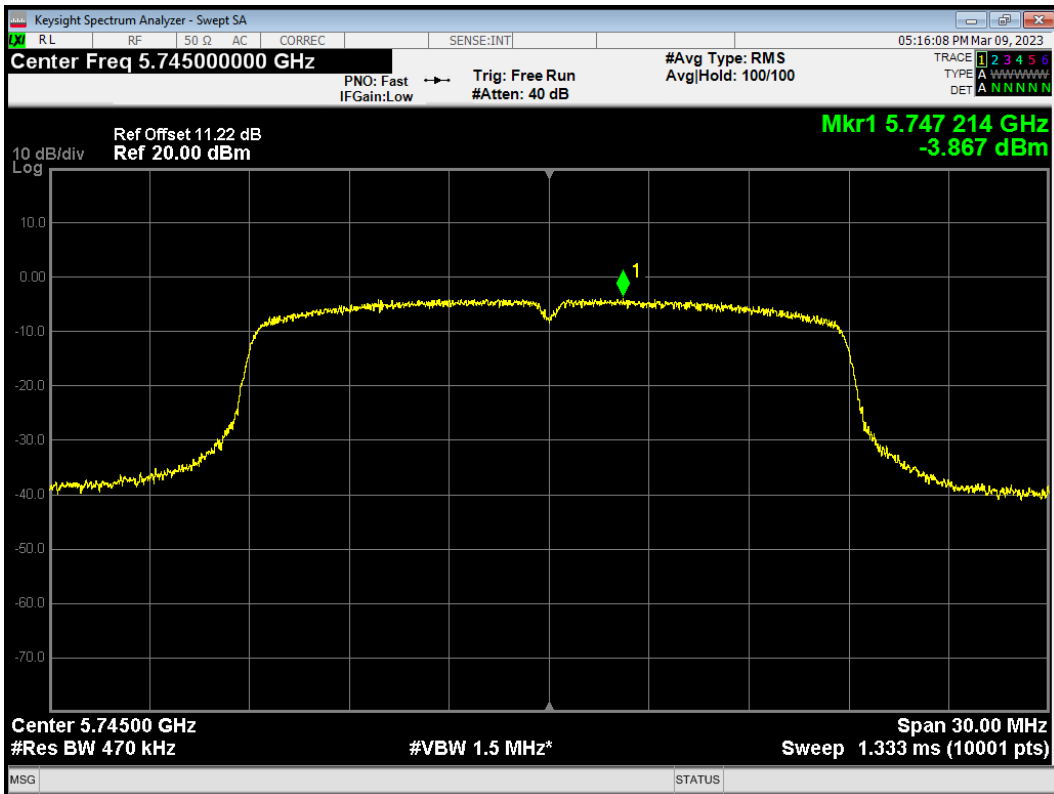

PSD 802.11n (HT20) 5785MHz Ant1

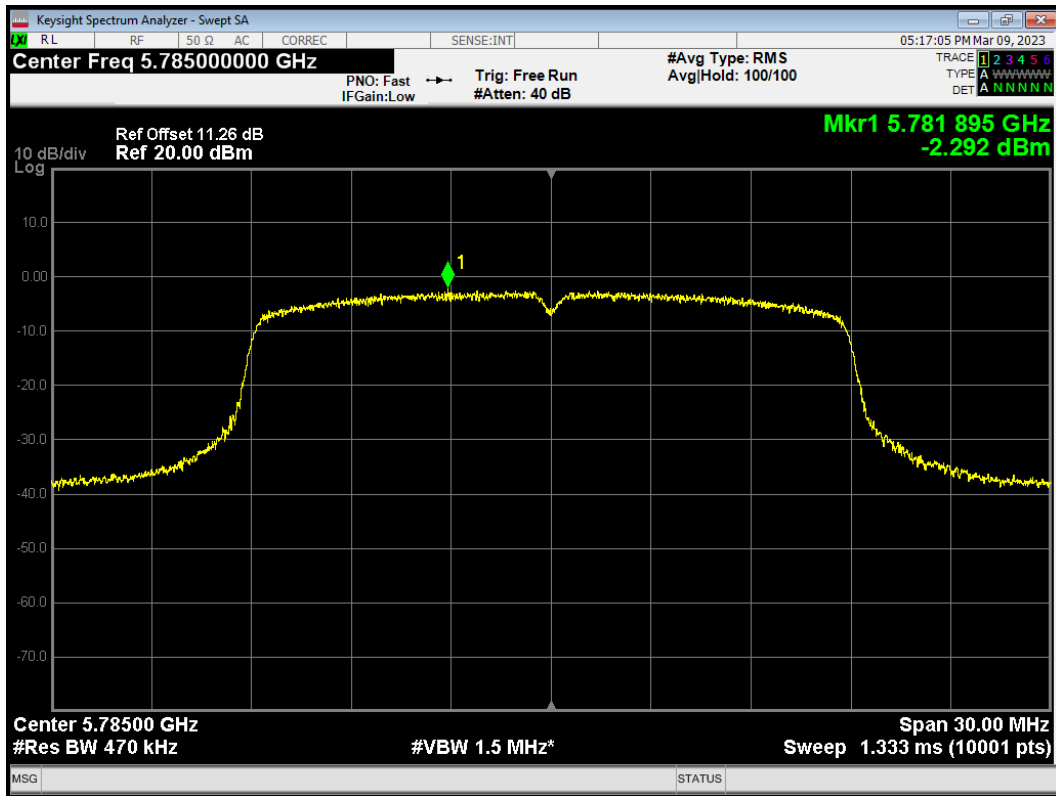

PSD 802.11n (HT20) 5785MHz Ant2

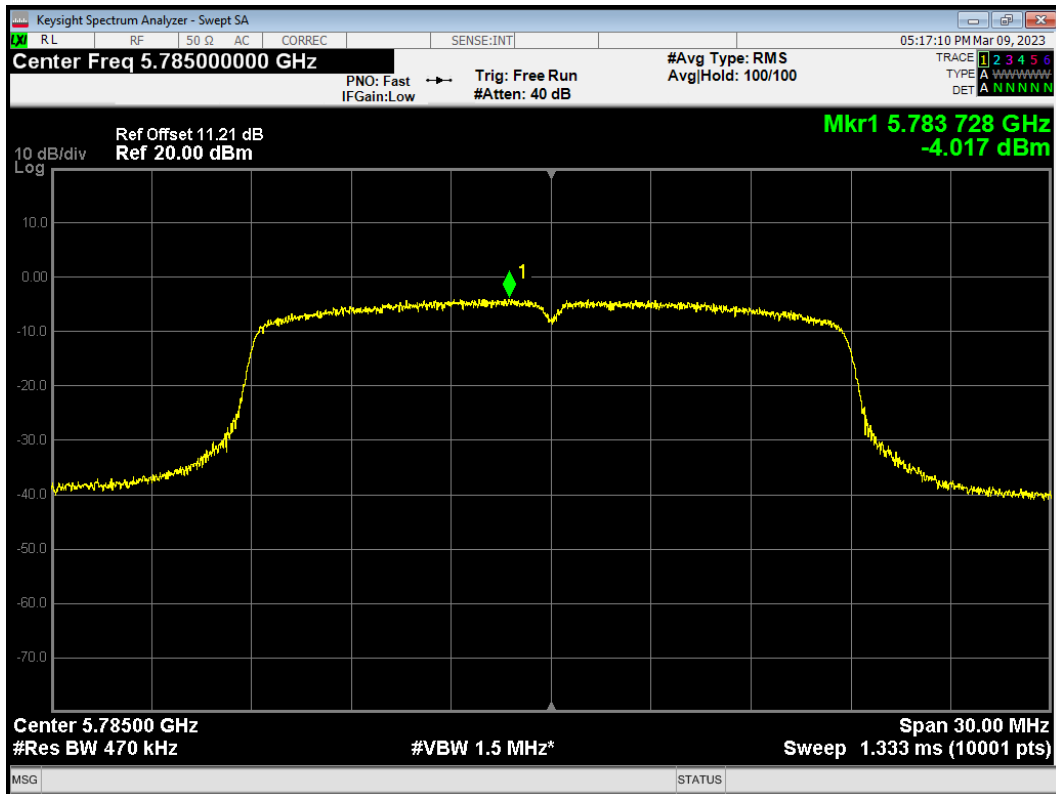

PSD 802.11n (HT20) 5825MHz Ant1

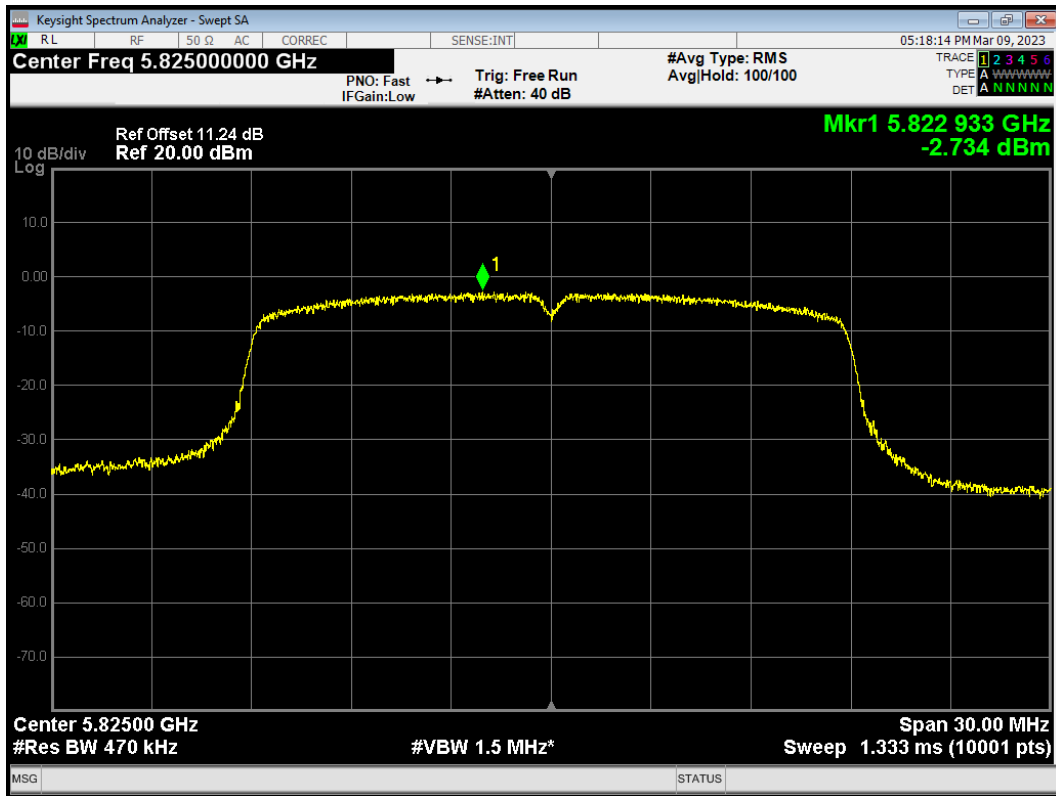

PSD 802.11n (HT20) 5825MHz Ant2

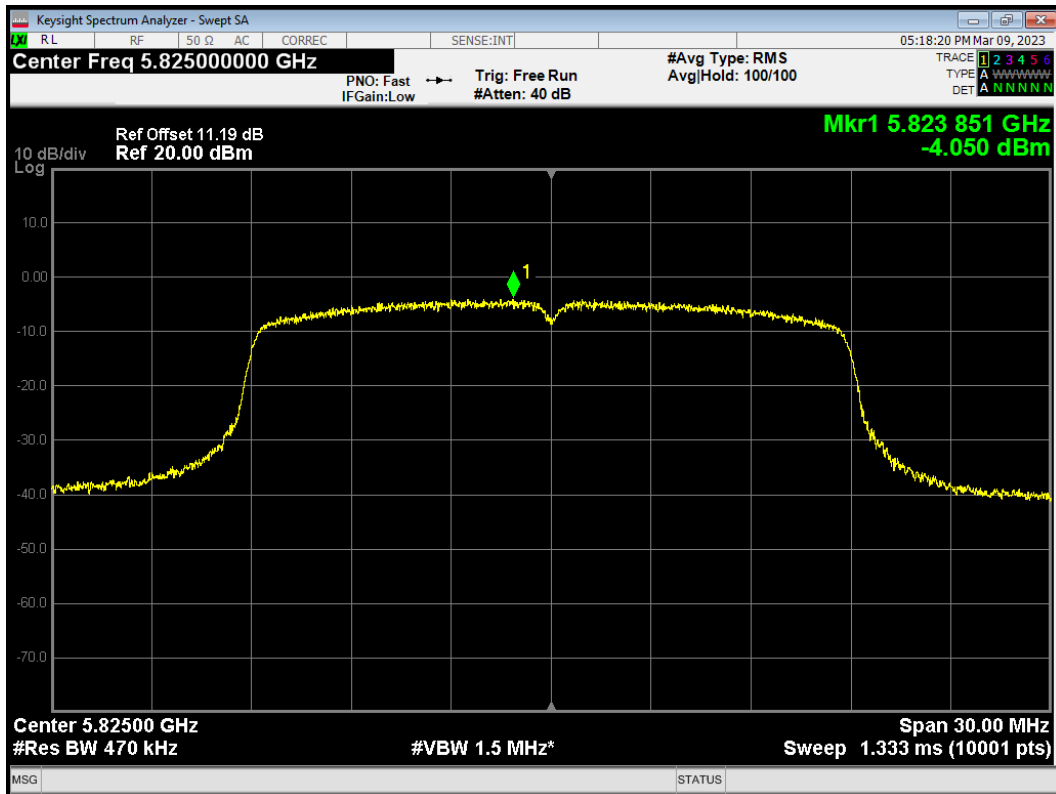

PSD 802.11n (HT40) 5710MHz Ant1

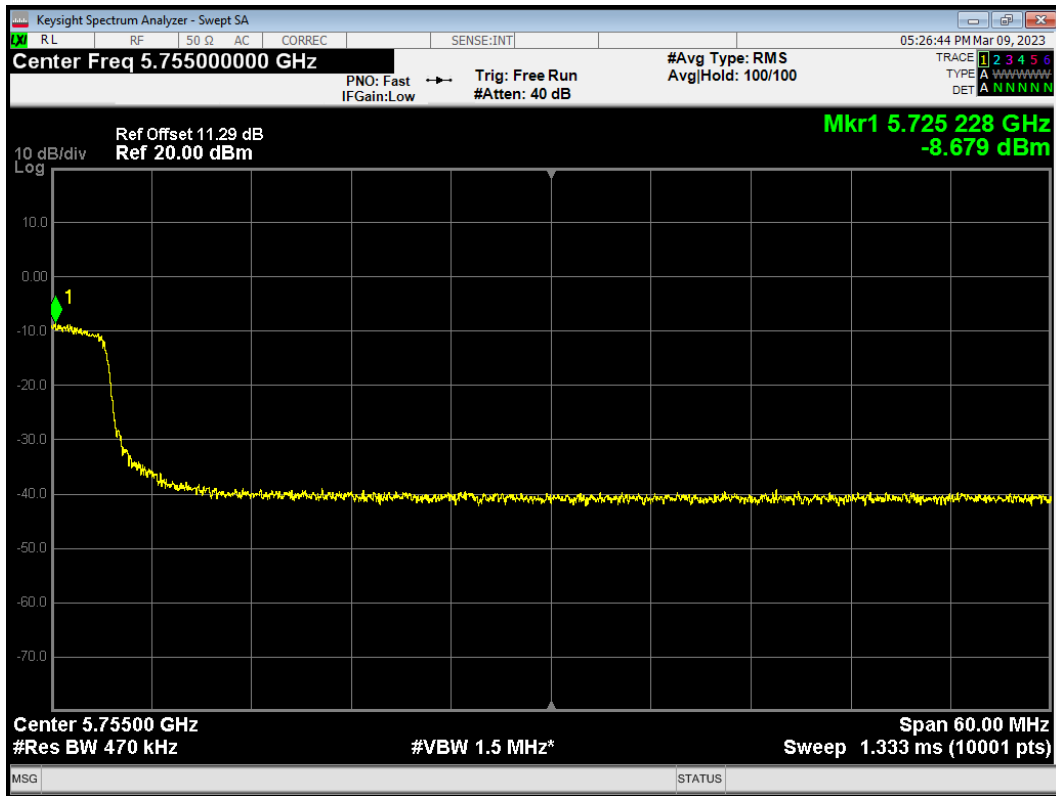

PSD 802.11n (HT40) 5710MHz Ant2

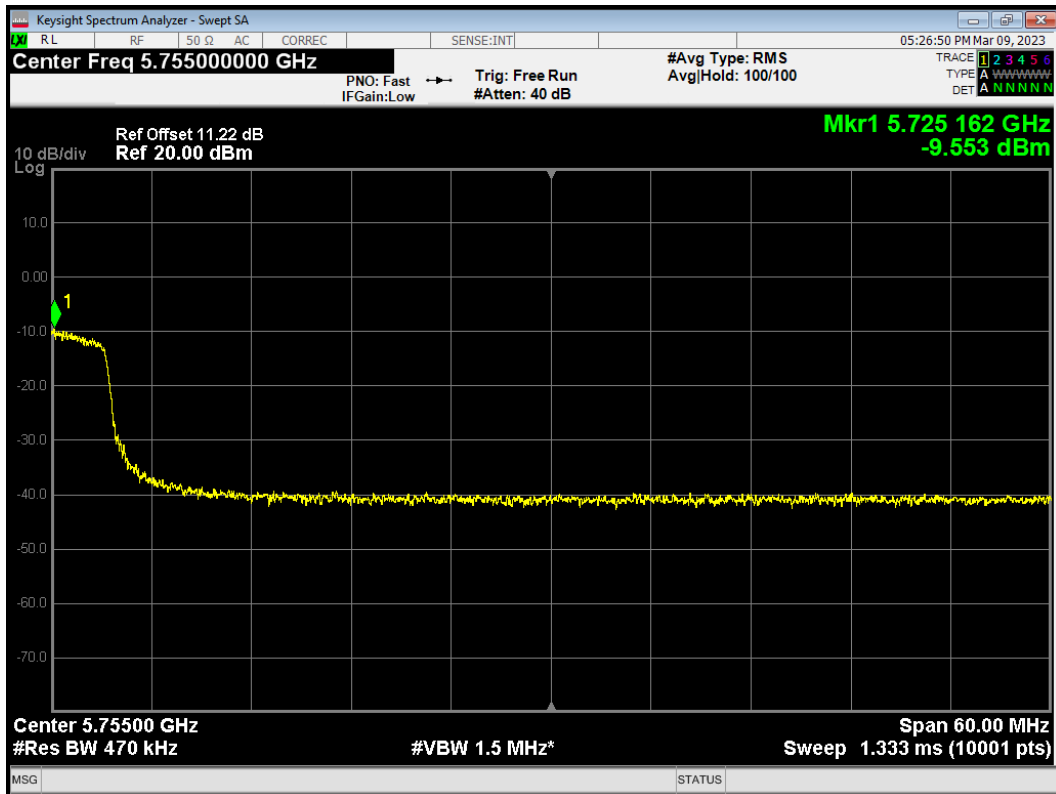

PSD 802.11n (HT40) 5755MHz Ant1

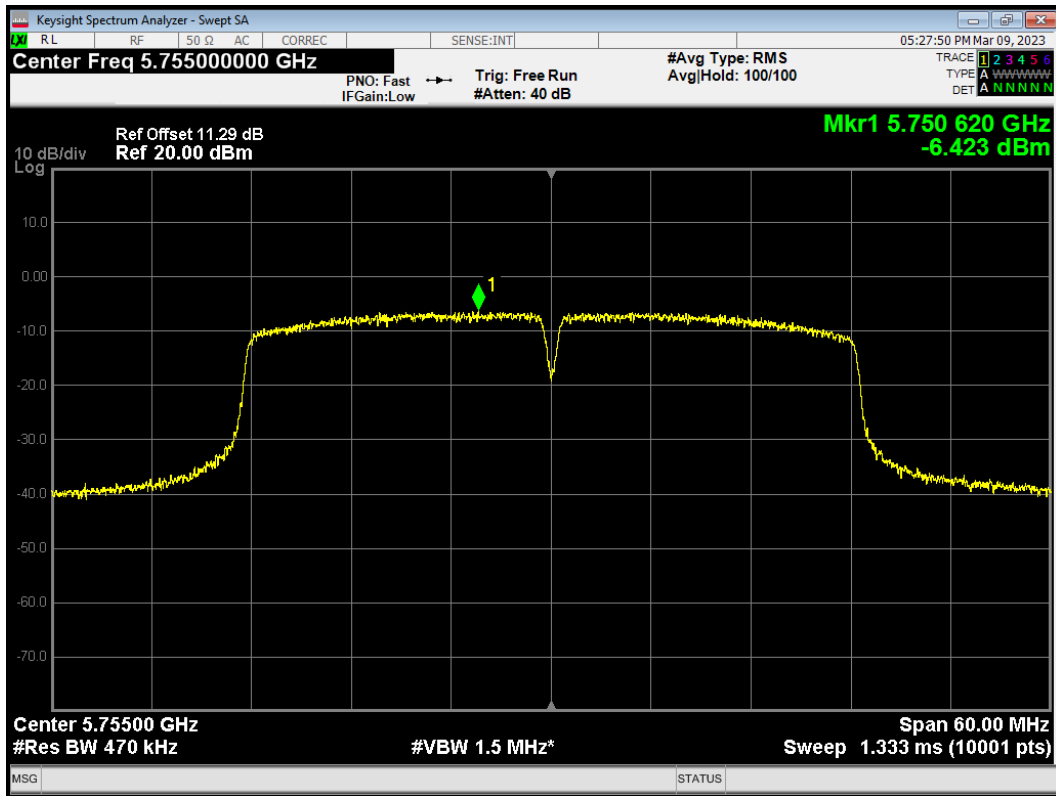

PSD 802.11n (HT40) 5755MHz Ant2

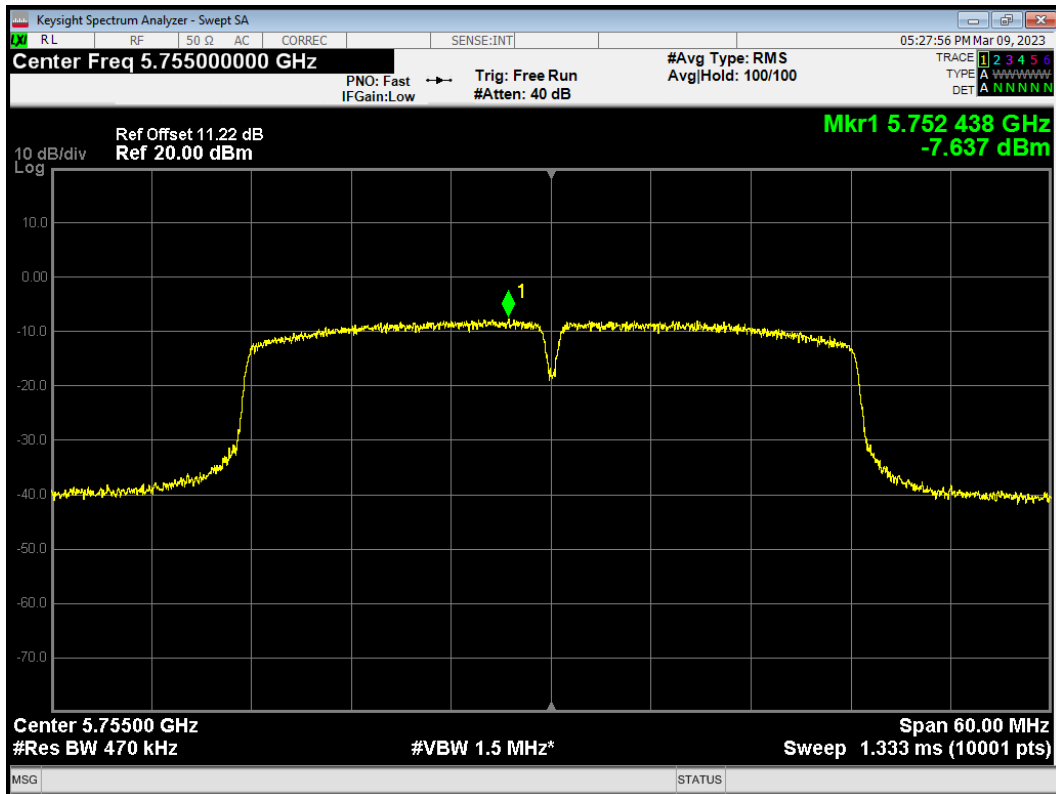

PSD 802.11n (HT40) 5795MHz Ant1

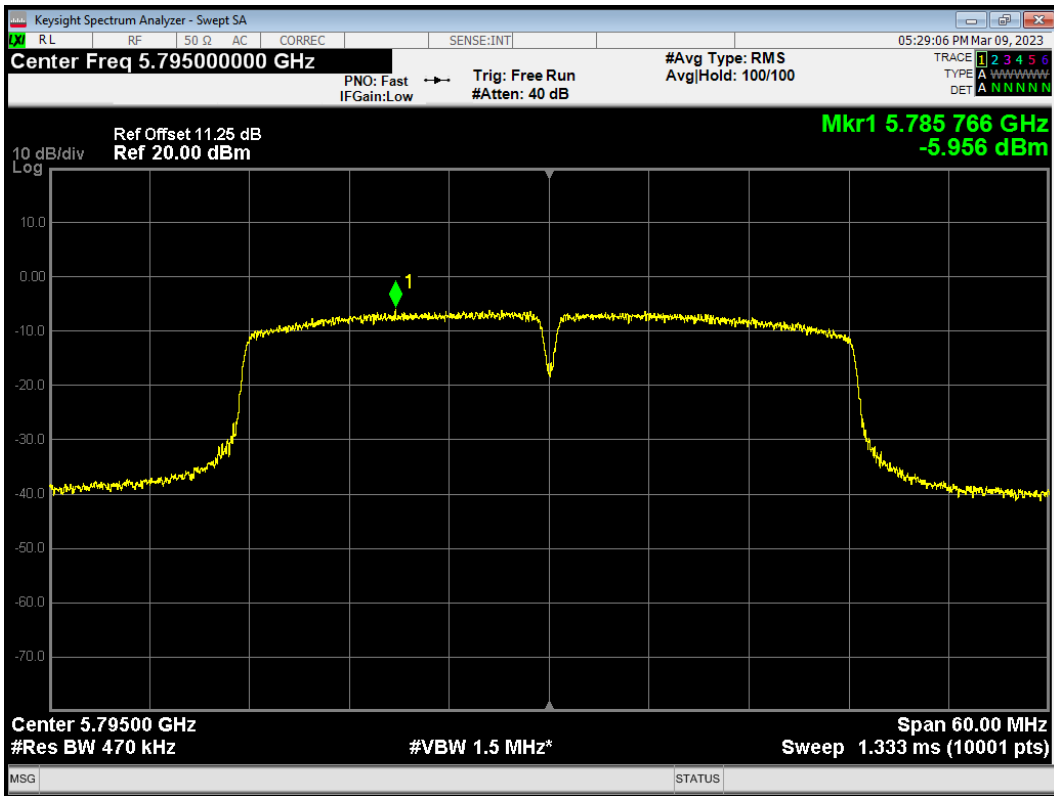

PSD 802.11n (HT40) 5795MHz Ant2

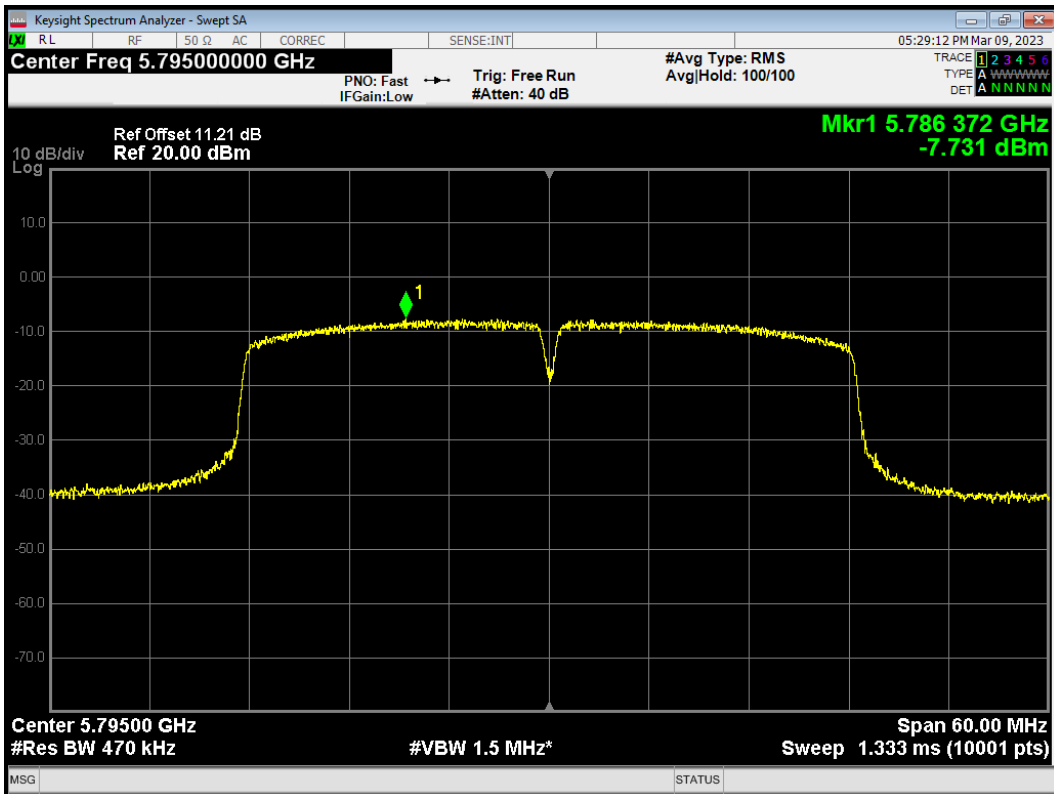

5.5. Unwanted Emission

Ambient condition

Temperature	Relative humidity
20°C ~25°C	45%~50%

Method of Measurement

The test set-up was made in accordance to the general provisions of ANSI C63.10. The Equipment Under Test (EUT) was set up on a non-conductive table in the semi-anechoic chamber. The test was performed at the distance of 3 m between the EUT and the receiving antenna. The radiated emissions measurements were made in a typical installation configuration.

Sweep the whole frequency band range from 9kHz to the 10th harmonic of the carrier, and the emissions less than 20 dB below the permissible value are reported.

During the test, the height of receive antenna shall be moved from 1 to 4 meters, and the antenna shall be performed under horizontal and vertical polarization. The turntable shall be rotated from 0 to 360 degrees for detecting the maximum of radiated spurious signal level. The measurements shall be repeated with orthogonal polarization of the test antenna. The data of cable loss and antenna factor has been calibrated in full testing frequency range before the testing.

Set the spectrum analyzer in the following:

9kHz~150 kHz

RBW=200Hz, VBW=1kHz/ Sweep=AUTO

150 kHz~30MHz

RBW=9KHz, VBW=30KHz,/ Sweep=AUTO

Below 1GHz

RBW=100kHz / VBW=300kHz / Sweep=AUTO

a) Peak emission levels are measured by setting the instrument as follows:

Above 1GHz

PEAK: RBW=1MHz VBW=3MHz/ Sweep=AUTO

b) Average emission levels are measured by setting the instrument as follows:

Above 1GHz

AVERAGE: RBW=1MHz / VBW=3MHz / Sweep=AUTO

c) Detector: The measurements employing a CISPR quasi-peak detector except for the frequency bands 9-90 kHz, 110-490 kHz and above 1000 MHz. Radiated emission limits in these three bands are based on measurements employing an average detector.

d) Averaging type = power (i.e., rms) (As an alternative, the detector and averaging type may be set for linear voltage averaging. Some instruments require linear display mode to use linear voltage averaging. Log or dB averaging shall not be used.)

e) Sweep time = auto.

f) Perform a trace average of at least 100 traces if the transmission is continuous. If the transmission is not continuous, then the number of traces shall be increased by a factor of 1 / D, where D is the duty cycle. For example, with 50% duty cycle, at least 200 traces shall be averaged. (If a specific emission is demonstrated to be continuous—i.e., 100% duty cycle—then rather than turning ON and

OFF with the transmit cycle, at least 100 traces shall be averaged.)

g) If tests are performed with the EUT transmitting at a duty cycle less than 98%, then a correction factor shall be added to the measurement results prior to comparing with the emission limit, to compute the emission level that would have been measured had the test been performed at 100% duty cycle. The correction factor is computed as follows:

1) If power averaging (rms) mode was used in the preceding step e), then the correction factor is $[10 \log (1 / D)]$, where D is the duty cycle. For example, if the transmit duty cycle was 50%, then 3 dB shall be added to the measured emission levels.

2) If linear voltage averaging mode was used in the preceding step e), then the correction factor is $[20 \log (1 / D)]$, where D is the duty cycle. For example, if the transmit duty cycle was 50%, then 6 dB shall be added to the measured emission levels.

3) If a specific emission is demonstrated to be continuous (100% duty cycle) rather than turning ON and OFF with the transmit cycle, then no duty cycle correction is required for that emission.

Reduce the video bandwidth until no significant variations in the displayed signal are observed in subsequent traces, provided the video bandwidth is no less than 1 Hz. For regulatory requirements that specify averaging only over the transmit duration (e.g., digital transmission system [DTS] and Unlicensed National Information Infrastructure [U-NII]), the video bandwidth shall be greater than $[1 / (\text{minimum transmitter on time})]$ and no less than 1 Hz.

The field strength of spurious emission was measured in the following position: EUT stand-up position (Z axis), lie-down position (X, Y axis). The worst emission was found in stand-up position (Z axis) and the loop antenna is vertical, others antenna are vertical and horizontal.

The test is in transmitting mode.

Test setup

9KHz~ 30MHz

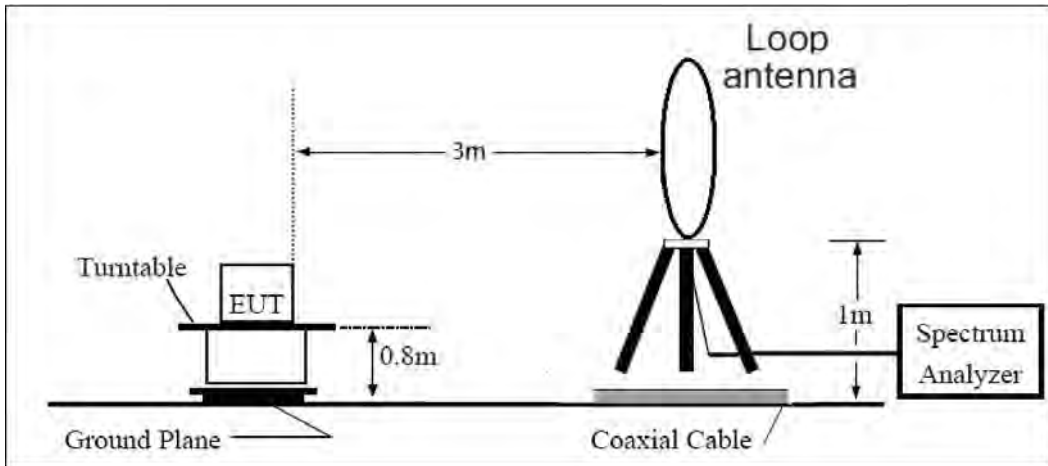

30MHz~ 1GHz

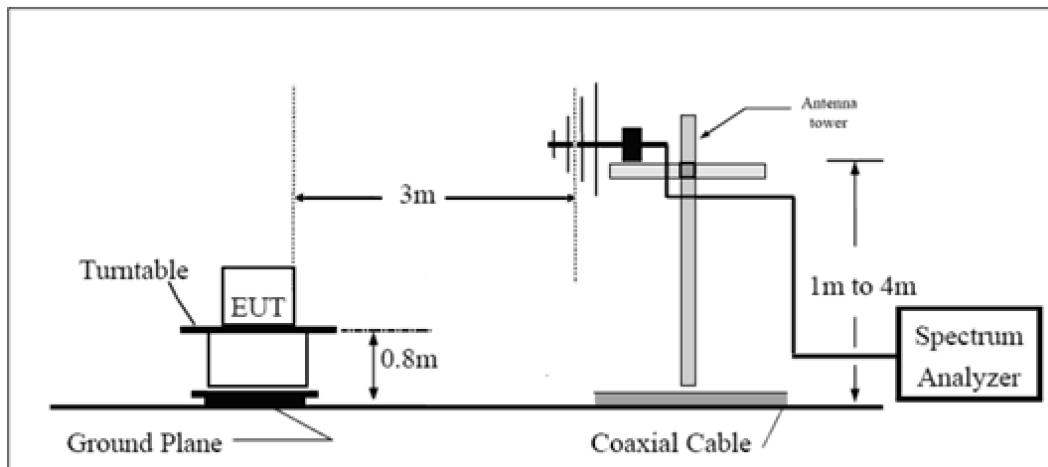

Above 1GHz

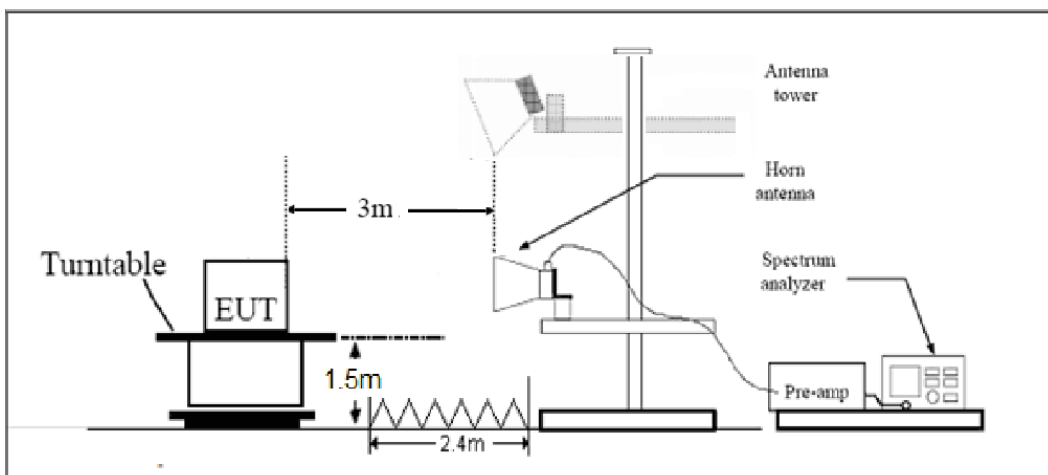

Note: Area side:2.4mX3.6m

Limits

- (1) For transmitters operating in the 5725-5850 MHz band: All emissions shall be limited to a level of -27 dBm/MHz at 75 MHz or more above or below the band edge increasing linearly to 10 dBm/MHz at 25 MHz above or below the band edge, and from 25 MHz above or below the band edge increasing linearly to a level of 15.6 dBm/MHz at 5 MHz above or below the band edge, and from 5 MHz above or below the band edge increasing linearly to a level of 27 dBm/MHz at the band edge.
- (2) For transmitters operating in the 5.15-5.25 GHz band: All emissions outside of the 5.15-5.35 GHz band shall not exceed an e.i.r.p. of -27 dBm/MHz(68.2dBμV/m).
- (3) For transmitters operating in the 5.25-5.35 GHz band: All emissions outside of the 5.15-5.35 GHz band shall not exceed an e.i.r.p. of -27 dBm/MHz(68.2dBμV/m).
- (4) For transmitters operating in the 5.47-5.725 GHz band: All emissions outside of the 5.47-5.725 GHz band shall not exceed an e.i.r.p. of -27 dBm/MHz(68.2dBμV/m).

Note: the following formula is used to convert the EIRP to field strength

§1、 $E[\text{dB}\mu\text{V}/\text{m}] = \text{EIRP}[\text{dBm}] - 20 \log(d[\text{meters}]) + 104.77$, where E = field strength and

d = distance at which field strength limit is specified in the rules;

§2、 $E[\text{dB}\mu\text{V}/\text{m}] = \text{EIRP}[\text{dBm}] + 95.2$, for d = 3 meters

- (5) Unwanted spurious emissions fallen in restricted bands per FCC Part15.205 shall comply with the general field strength limits set forth in § 15.209 as below table.

Frequency of emission (MHz)	Field strength($\mu\text{V}/\text{m}$)	Field strength($\text{dB}\mu\text{V}/\text{m}$)
0.009–0.490	2400/F(kHz)	/
0.490–1.705	24000/F(kHz)	/
1.705–30.0	30	/
30-88	100	40
88-216	150	43.5
216-960	200	46
Above960	500	54

MHz	MHz	MHz	GHz
0.090 - 0.110	16.42 - 16.423	399.9 - 410	4.5 - 5.15
0.495 - 0.505	16.69475 - 16.69525	608 - 614	5.35 - 5.46
2.1735 - 2.1905	16.80425 - 16.80475	960 - 1240	7.25 - 7.75
4.125 - 4.128	25.5 - 25.67	1300 - 1427	8.025 - 8.5
4.17725 - 4.17775	37.5 - 38.25	1435 - 1626.5	9.0 - 9.2
4.20725 - 4.20775	73 - 74.6	1645.5 - 1646.5	9.3 - 9.5
6.215 - 6.218	74.8 - 75.2	1660 - 1710	10.6 - 12.7
6.26775 - 6.26825	108 - 121.94	1718.8 - 1722.2	13.25 - 13.4
6.31175 - 6.31225	123 - 138	2200 - 2300	14.47 - 14.5
8.291 - 8.294	149.9 - 150.05	2310 - 2390	15.35 - 16.2
8.362 - 8.366	156.52475 - 156.52525	2483.5 - 2500	17.7 - 21.4
8.37625 - 8.38675	156.7 - 156.9	2690 - 2900	22.01 - 23.12
8.41425 - 8.41475	162.0125 - 167.17	3260 - 3267	23.6 - 24.0
12.29 - 12.293	167.72 - 173.2	3332 - 3339	31.2 - 31.8
12.51975 - 12.52025	240 - 285	3345.8 - 3358	36.43 - 36.5
12.57675 - 12.57725	322 - 335.4	3600 - 4400	(²)
13.36 - 13.41			

Measurement Uncertainty

The assessed measurement uncertainty to ensure 95% confidence level for the normal distribution is with the coverage factor $k = 1.96$.

Frequency	Uncertainty
9KHz-30MHz	3.55 dB
30MHz-200MHz	4.17 dB
200MHz-1GHz	4.84 dB
1-18GHz	4.35 dB
18-26.5GHz	5.90 dB
26.5GHz~40GHz	5.92 dB

Test Results:

The modulation and bandwidth are similar for 802.11n mode for 20MHz/40MHz and 802.11ac mode for V20MHz/V40MHz, therefore investigated worst case to representative mode in test report.

A symbol (dB V/) in the test plot below means ($\text{dB}\mu\text{V/m}$)

The signal beyond the limit is carrier.

U-NII-1

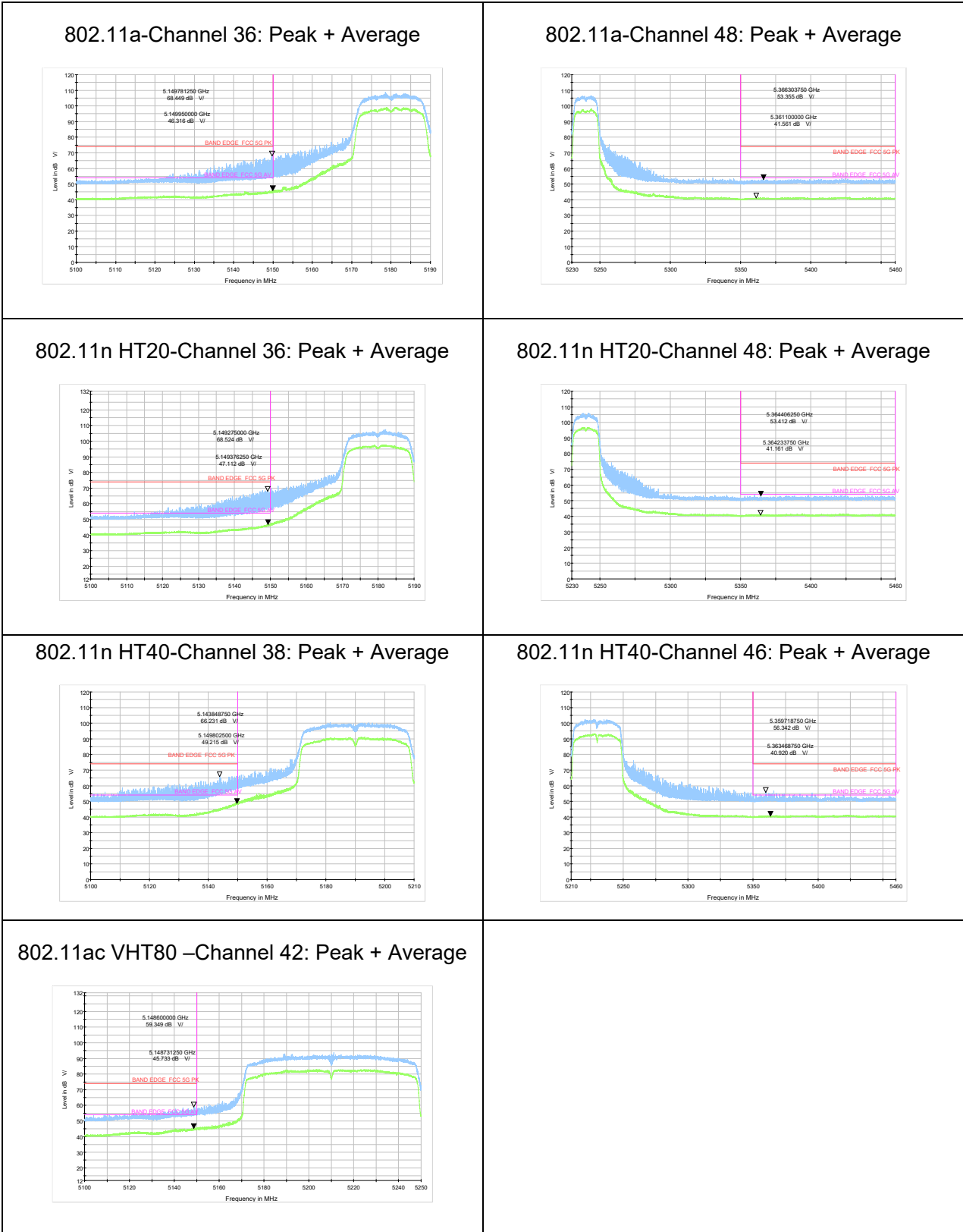

U-NII-2A

802.11a-Channel 52: Peak + Average

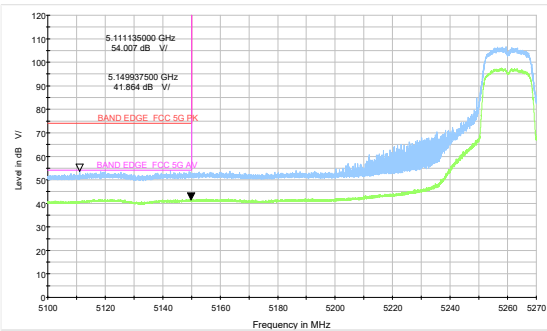

802.11a-Channel 64: Peak + Average

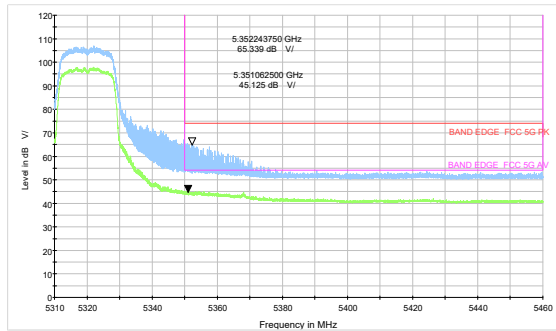

802.11n HT20-Channel 52: Peak + Average

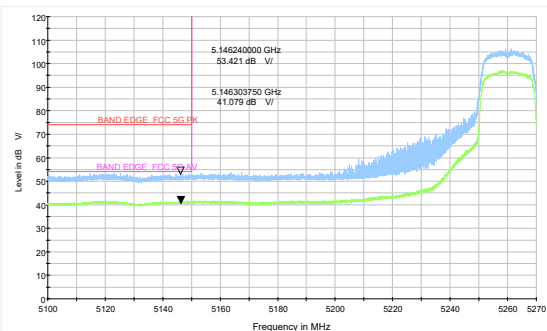

802.11n HT20-Channel 64: Peak + Average

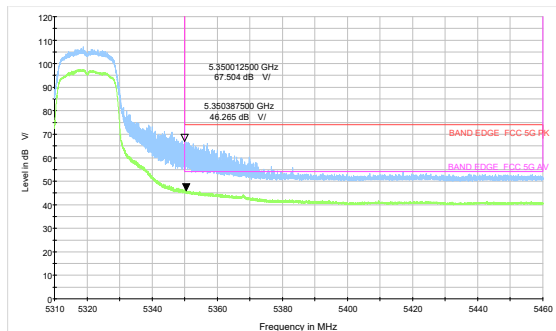

802.11n HT40-Channel 54: Peak + Average

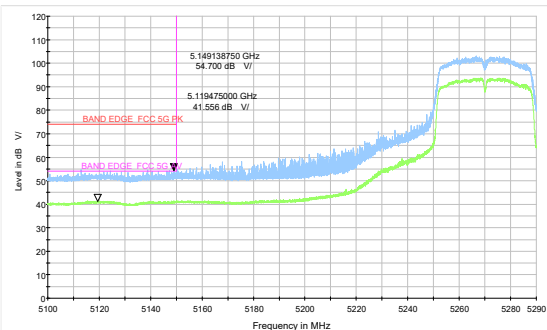

802.11n HT40-Channel 62: Peak + Average

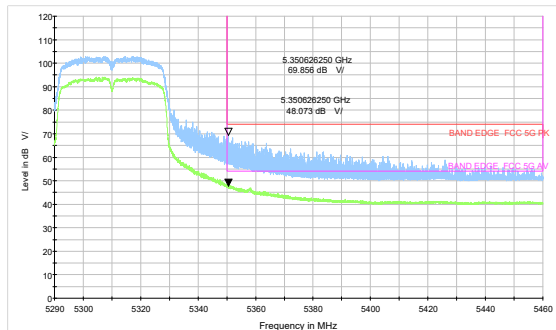

802.11ac VHT80 -Channel 58: Peak + Average

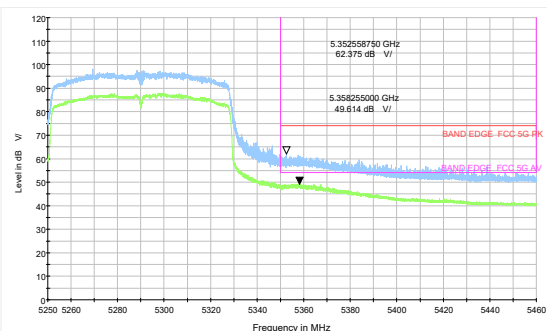

U-NII-2C

802.11a-Channel 100: Peak + Average

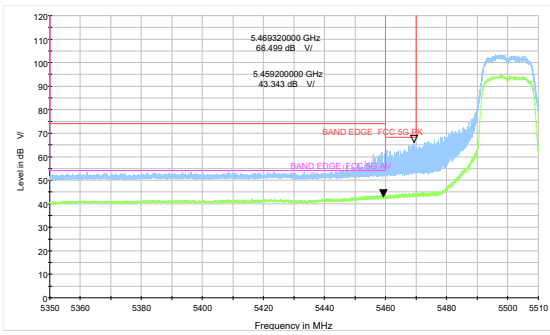

802.11a-Channel 104: Peak + Average

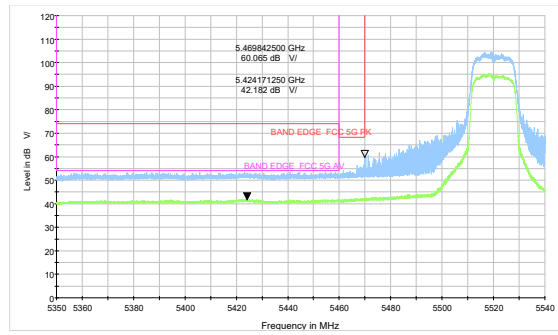

802.11a-Channel 120: Peak + Average

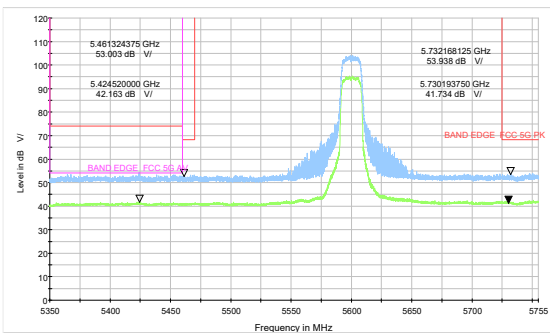

802.11a-Channel 136: Peak

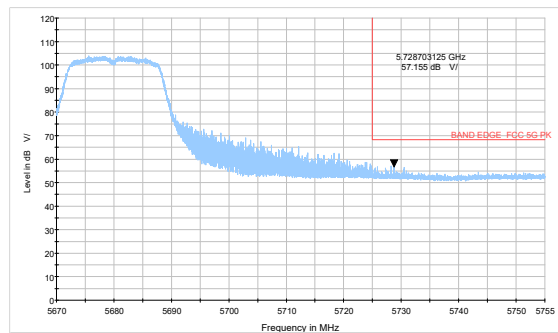

802.11a-Channel 140: Peak

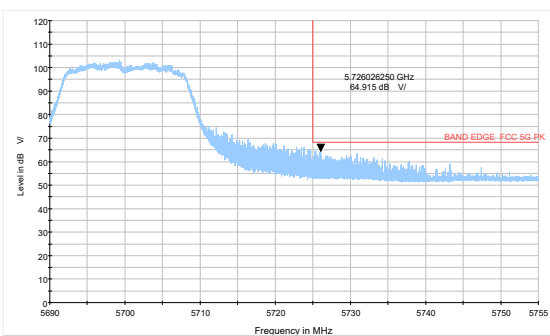

802.11a-Channel 144: Peak

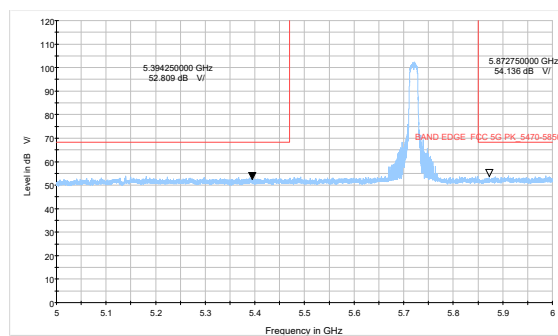

802.11n HT20-Channel 100: Peak + Average

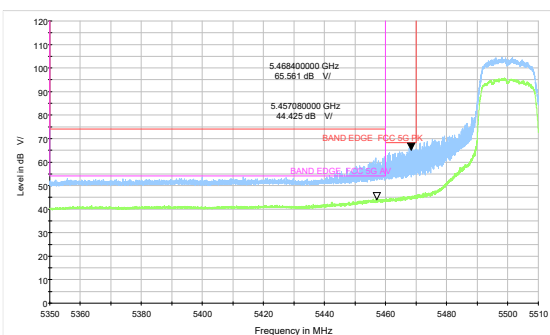

802.11n HT20-Channel 120: Peak + Average

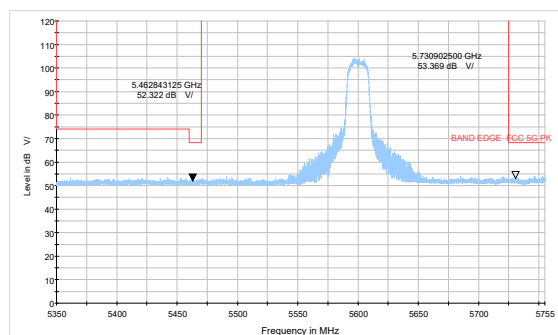

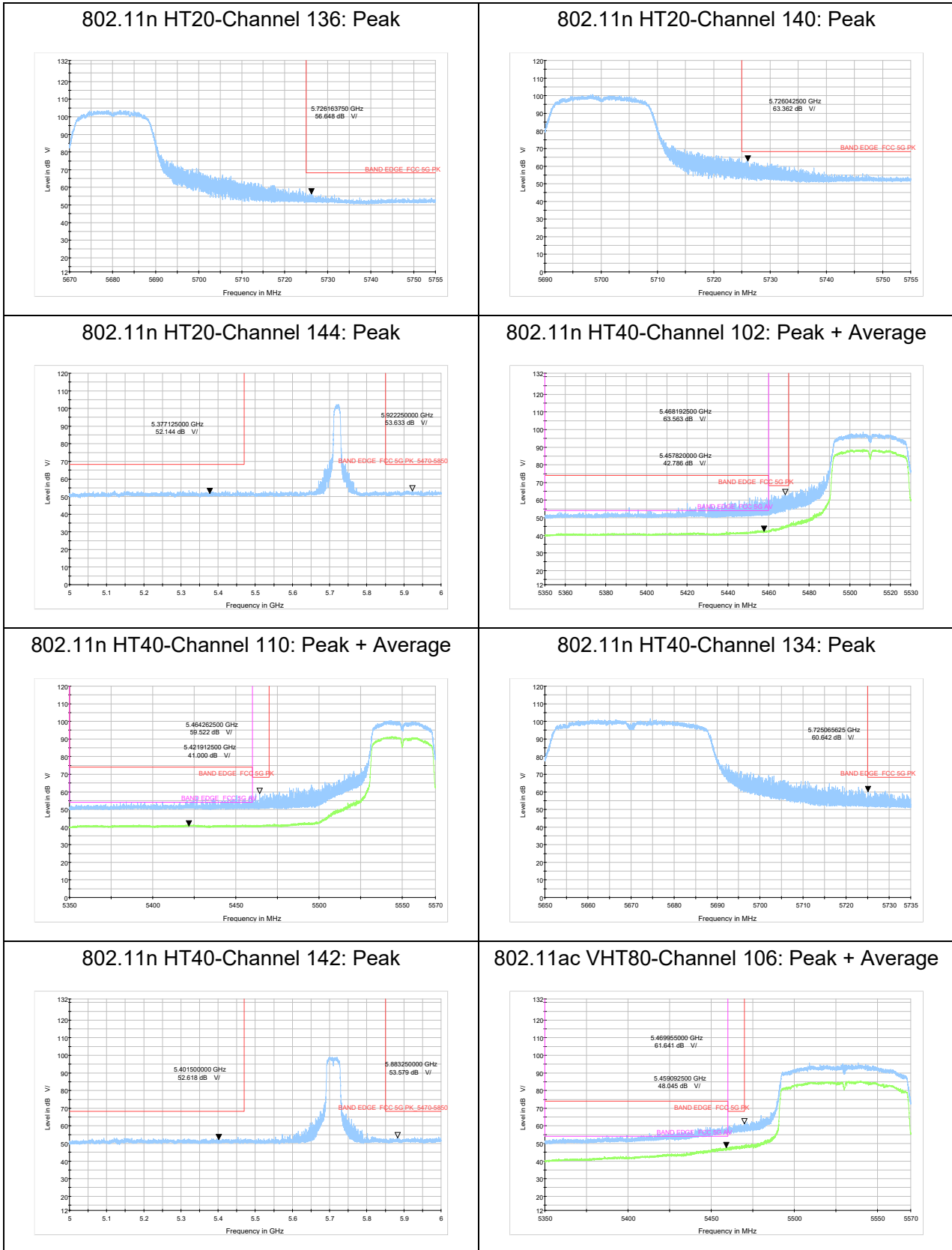

802.11ac VHT40-Channel 122: Peak

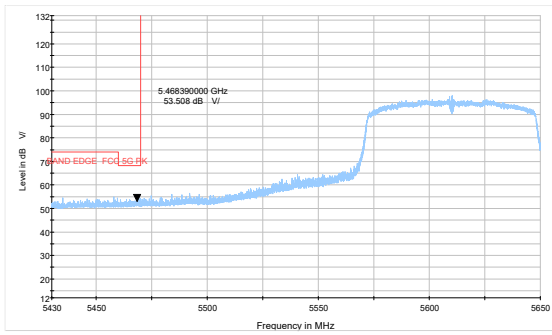

802.11ac VHT80- Channel 138: Peak

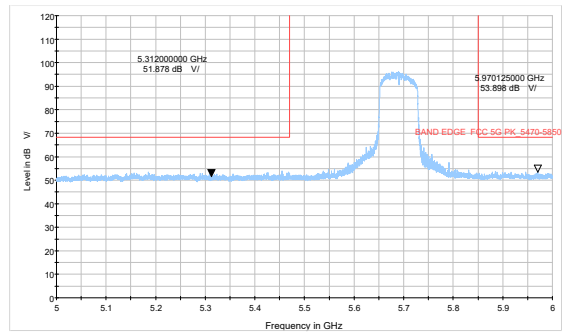

U-NII-3

802.11a-Channel 149: Peak

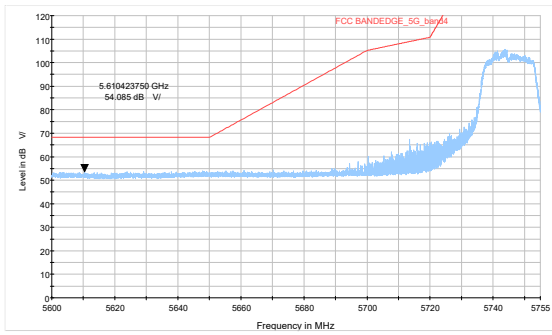

802.11a-Channel 165: Peak

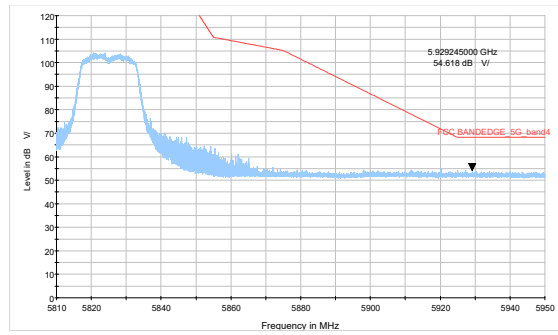

802.11n HT20-Channel 149: Peak

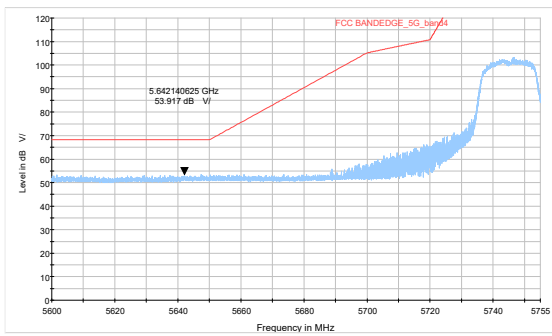

802.11n HT20-Channel 165: Peak

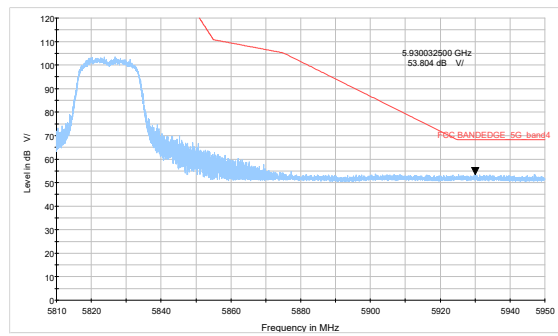

802.11n HT40-Channel 151: Peak

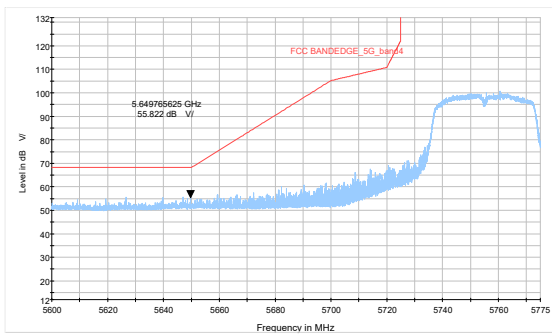

802.11n HT40-Channel 159: Peak

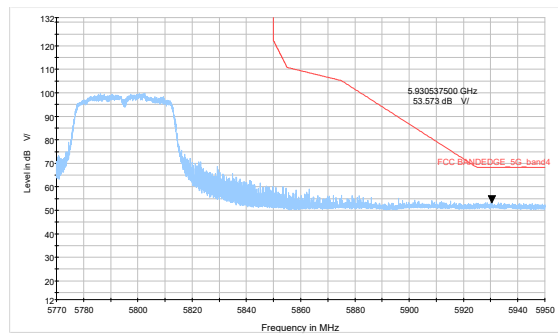

802.11ac VHT80- Channel 155: Peak

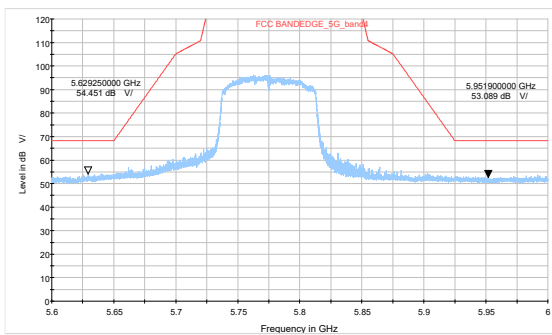

Result of RE

Test result

Sweep the whole frequency band through the range from 9kHz to the 10th harmonic of the carrier, the Emissions in the frequency band 9kHz-30MHz and 26.5GHz-40GHz are more than 20dB below the limit are not reported.

After the pretest, CDD/MIMO was selected as the worst antenna.

A symbol (dB V/) in the test plot below means (dBμV/m)

During the test, the Radiates Emission from 30MHz to 1GHz was performed in all modes with all channels, 802.11a, Channel 116 are selected as the worst condition. The test data of the worst-case condition was recorded in this report.

Continuous TX mode:

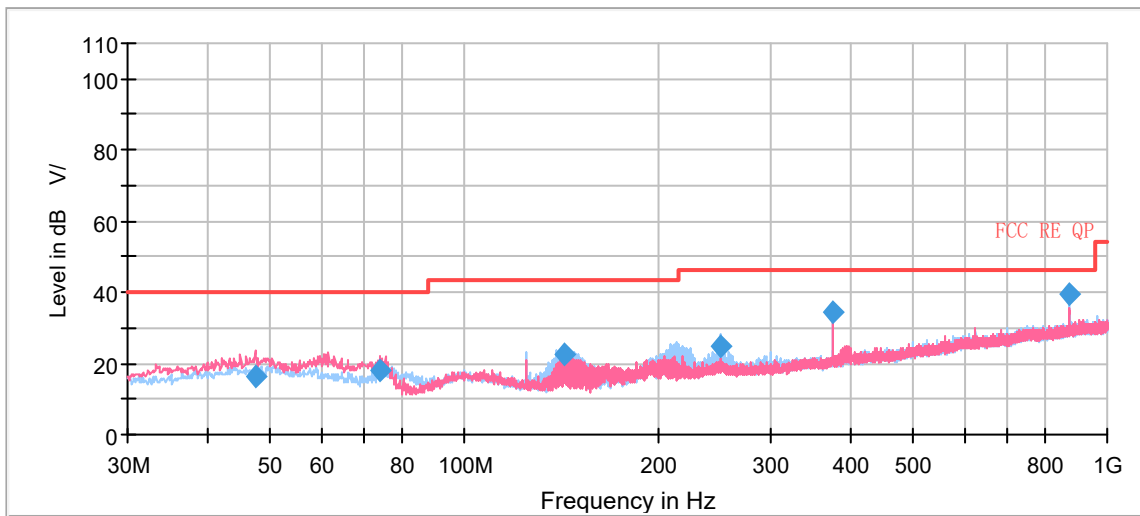

Radiates Emission from 30MHz to 1GHz

Frequency (MHz)	Quasi-Peak (dBμV/m)	Limit (dBμV/m)	Margin (dB)	Height (cm)	Polarization	Azimuth (deg)	Correct Factor (dB)
47.575444	16.19	40.00	23.81	109.0	V	319.0	20.5
73.883681	18.05	40.00	21.95	185.0	V	328.0	14.8
143.371750	22.57	43.50	20.93	184.0	H	232.0	14.8
250.018000	25.02	46.00	20.98	100.0	H	0.0	19.9
375.001250	34.31	46.00	11.69	100.0	H	4.0	22.4
874.977000	39.60	46.00	6.40	100.0	H	86.0	29.9

Remark: 1. Correction Factor = Antenna factor + Insertion loss (cable loss + amplifier gain)

2. Margin = Limit – Quasi-Peak

802.11a CH36

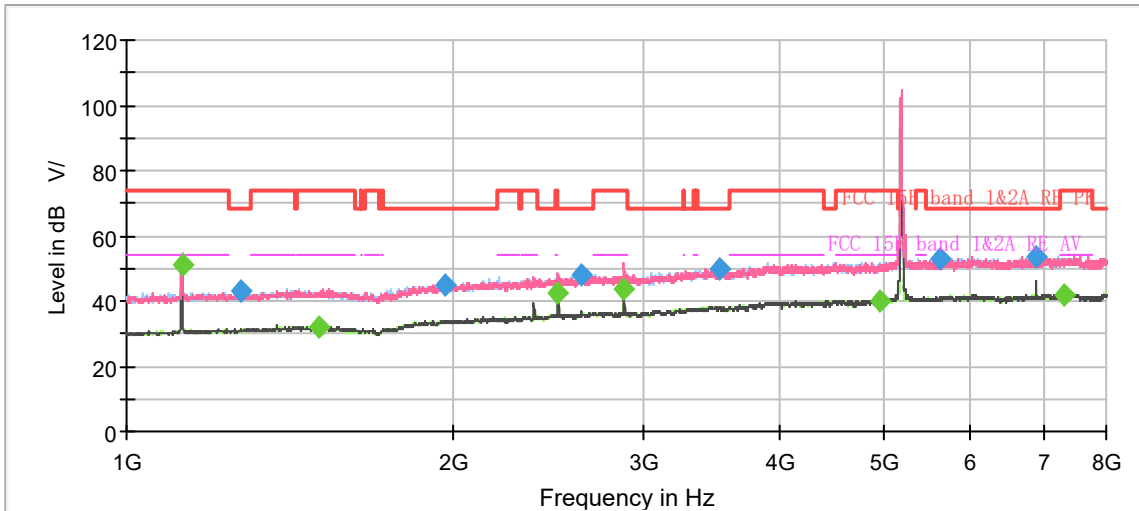

Note: The signal beyond the limit is carrier.
Radiates Emission from 1GHz to 8GHz

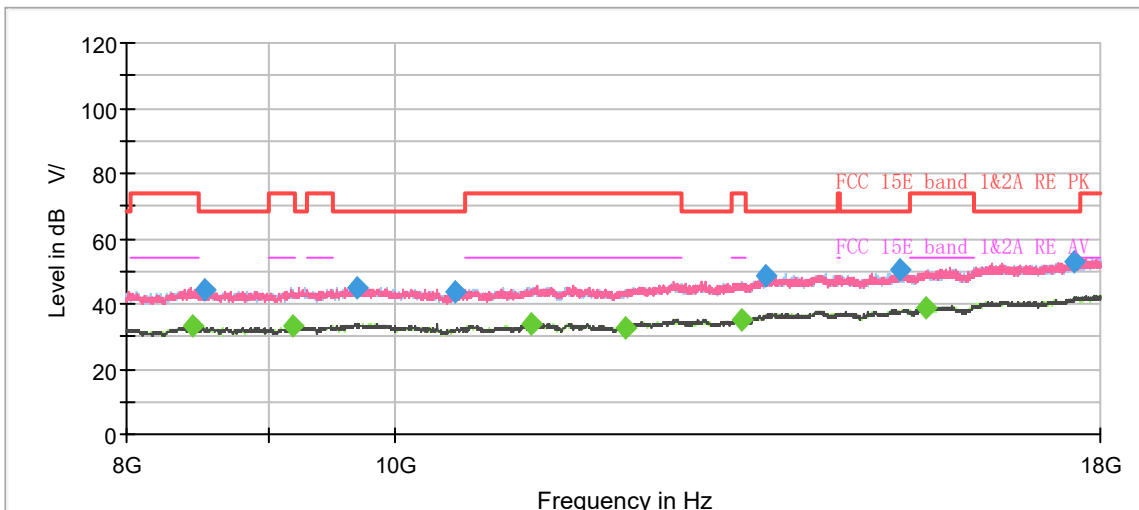

Radiates Emission from 8GHz to 18GHz

Frequency (MHz)	MaxPeak (dB μ V/m)	Average (dB μ V/m)	Limit (dB μ V/m)	Margin (dB)	Meas. Time (ms)	Height (cm)	Pol	Azimuth (deg)	Corr. (dB/m)
1124.250000	---	51.03	54.00	2.97	500.0	200.0	H	82.0	-8.2
1272.125000	42.92	---	68.20	25.28	500.0	200.0	V	88.0	-7.3
1503.125000	---	32.05	54.00	21.95	500.0	200.0	V	43.0	-5.9
1962.500000	45.20	---	68.20	23.00	500.0	100.0	H	51.0	-3.6
2499.750000	---	42.41	54.00	11.59	500.0	200.0	V	230.0	-1.2
2629.250000	47.97	---	68.20	20.23	500.0	200.0	H	194.0	-0.5
2875.125000	---	43.60	54.00	10.40	500.0	200.0	V	167.0	0.2
3527.875000	50.00	---	68.20	18.20	500.0	100.0	V	285.0	2.6
4940.125000	---	40.08	54.00	13.92	500.0	100.0	H	42.0	6.2
5631.375000	53.14	---	68.20	15.06	500.0	200.0	H	270.0	8.0
6907.125000	53.64	---	68.20	14.56	500.0	200.0	V	29.0	8.8
7307.000000	---	42.10	54.00	11.90	500.0	200.0	V	25.0	9.3

Remark: 1. Correction Factor = Antenna factor + Insertion loss (cable loss + amplifier gain)

2. Margin = Limit –MAX Peak/ Average

802.11a CH40

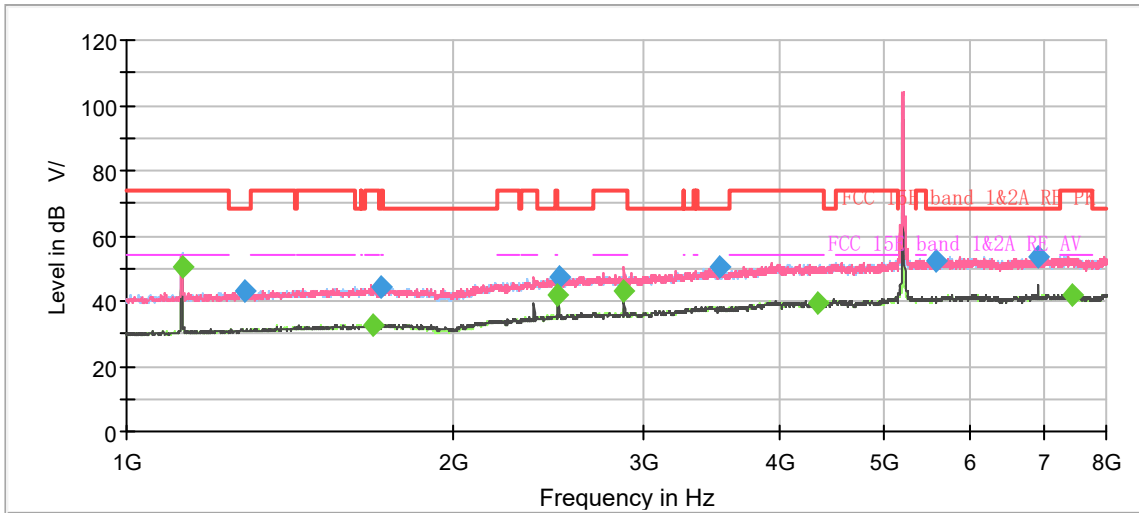

Note: The signal beyond the limit is carrier.
Radiates Emission from 1GHz to 8GHz

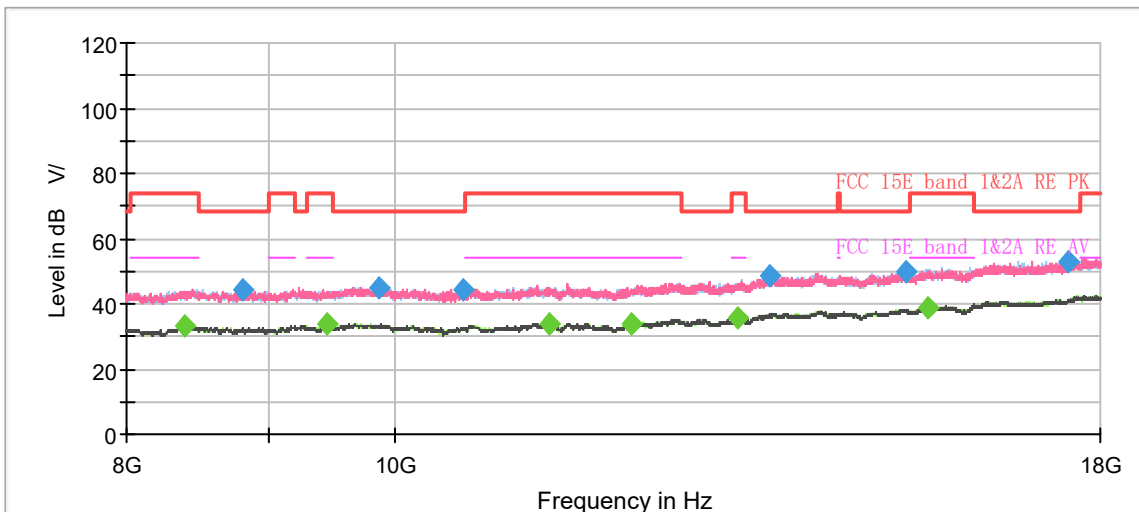

Radiates Emission from 8GHz to 18GHz

Frequency (MHz)	MaxPeak (dB μ V/m)	Average (dB μ V/m)	Limit (dB μ V/m)	Margin (dB)	Meas. Time (ms)	Height (cm)	Pol	Azimuth (deg)	Corr. (dB/m)
1124.250000	---	50.65	54.00	3.35	500.0	200.0	H	84.0	-8.2
1286.125000	43.04	---	68.20	25.16	500.0	100.0	V	349.0	-7.2
1688.625000	---	32.87	54.00	21.13	500.0	100.0	V	23.0	-5.0
1717.500000	44.03	---	68.20	24.17	500.0	200.0	H	358.0	-4.9
2499.750000	---	42.04	54.00	11.96	500.0	200.0	V	195.0	-1.2
2500.625000	47.29	---	68.20	20.91	500.0	200.0	V	278.0	-1.2
2875.125000	---	43.35	54.00	10.65	500.0	200.0	V	161.0	0.2
3516.500000	50.31	---	68.20	17.89	500.0	100.0	V	219.0	2.6
4339.875000	---	39.31	54.00	14.69	500.0	200.0	V	200.0	4.8
5571.000000	52.50	---	68.20	15.70	500.0	100.0	H	88.0	7.9
6933.375000	53.69	---	68.20	14.51	500.0	200.0	V	26.0	8.8
7428.625000	---	42.15	54.00	11.85	500.0	200.0	H	201.0	9.2

Remark: 1. Correction Factor = Antenna factor + Insertion loss (cable loss + amplifier gain)

2. Margin = Limit –MAX Peak/ Average

802.11a CH48

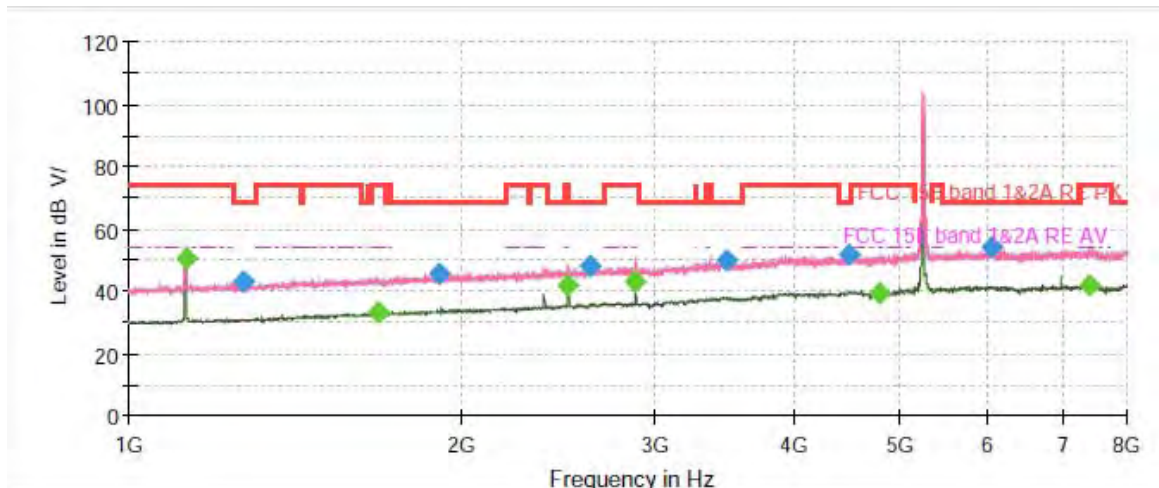

Note: The signal beyond the limit is carrier.
Radiates Emission from 1GHz to 8GHz

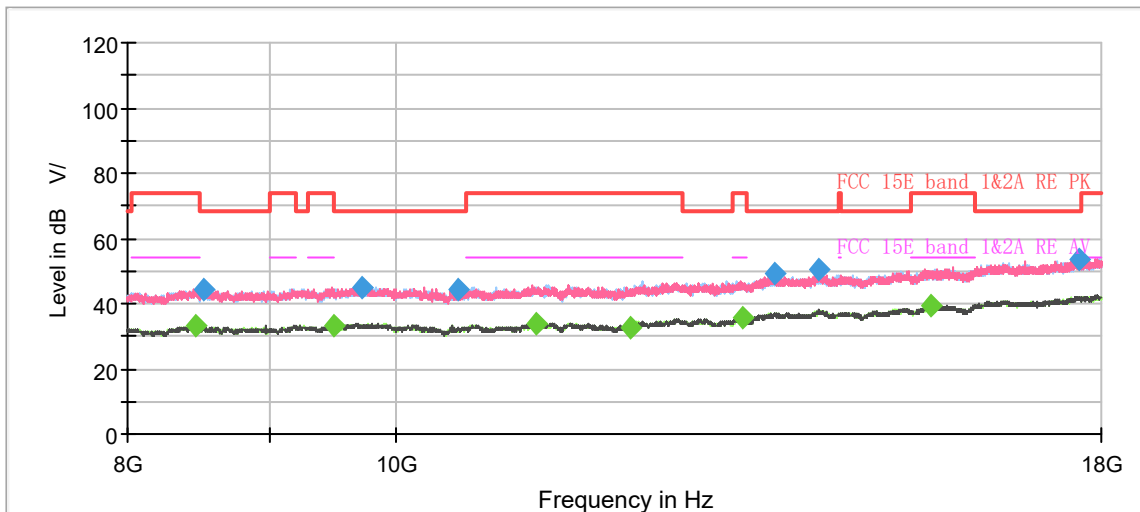

Radiates Emission from 8GHz to 18GHz

Frequency (MHz)	MaxPeak (dB μ V/m)	Average (dB μ V/m)	Limit (dB μ V/m)	Margin (dB)	Meas. Time (ms)	Height (cm)	Pol	Azimuth (deg)	Corr. (dB/m)
1124.250000	---	50.38	54.00	3.62	500.0	200.0	H	87.0	-8.2
1266.875000	43.00	---	68.20	25.20	500.0	200.0	H	239.0	-7.4
1679.875000	---	33.23	54.00	20.77	500.0	100.0	H	128.0	-5.0
1909.125000	45.65	---	68.20	22.55	500.0	100.0	V	97.0	-3.9
2499.750000	---	42.10	54.00	11.90	500.0	200.0	V	232.0	-1.2
2613.500000	47.74	---	68.20	20.46	500.0	200.0	H	103.0	-0.6
2875.125000	---	43.07	54.00	10.93	500.0	200.0	V	160.0	0.2
3472.750000	50.08	---	68.20	18.12	500.0	100.0	H	0.0	2.5
4477.250000	51.53	---	68.20	16.67	500.0	100.0	V	144.0	5.4
4788.750000	---	39.37	54.00	14.63	500.0	100.0	H	6.0	5.7
6037.375000	54.37	---	68.20	13.83	500.0	200.0	H	314.0	8.1
7398.875000	---	42.06	54.00	11.94	500.0	200.0	H	235.0	9.3

Remark: 1. Correction Factor = Antenna factor + Insertion loss (cable loss + amplifier gain)

2. Margin = Limit –MAX Peak/ Average

802.11a CH52

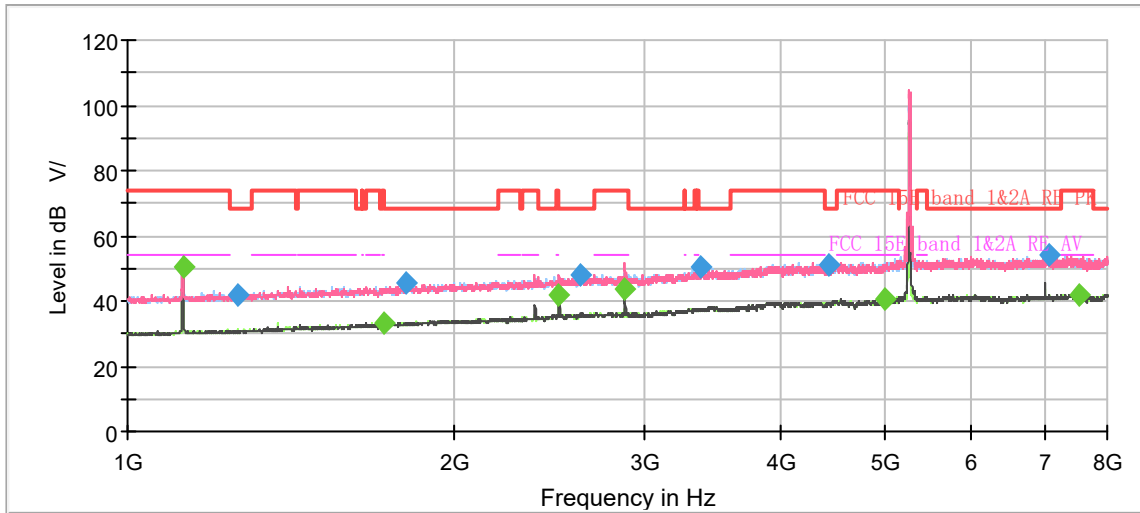

Note: The signal beyond the limit is carrier.
Radiates Emission from 1GHz to 8GHz

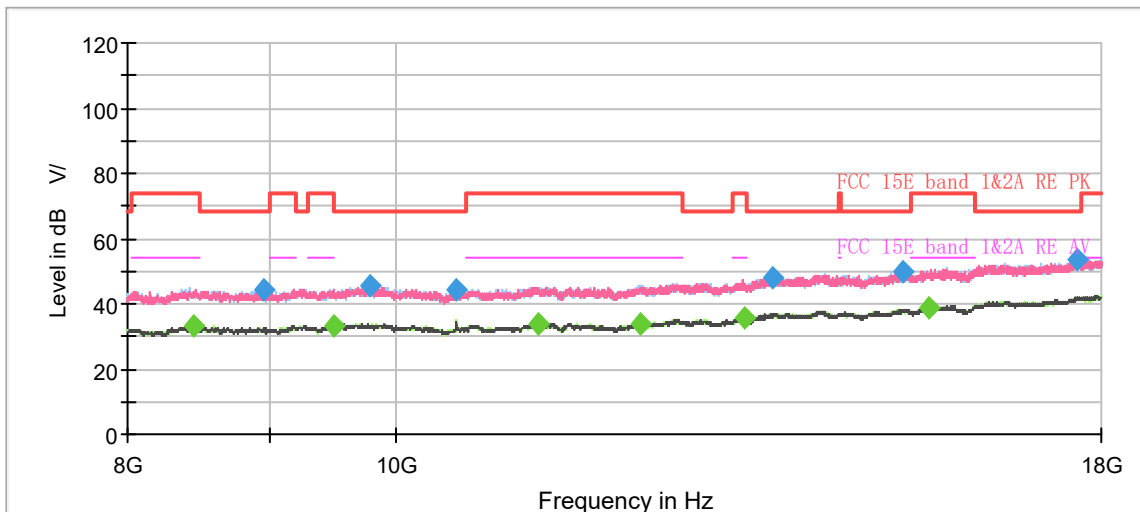

Radiates Emission from 8GHz to 18GHz

Frequency (MHz)	MaxPeak (dB μ V/m)	Average (dB μ V/m)	Limit (dB μ V/m)	Margin (dB)	Meas. Time (ms)	Height (cm)	Pol	Azimuth (deg)	Corr. (dB/m)
1124.250000	---	50.27	54.00	3.73	500.0	200.0	H	83.0	-8.2
1264.250000	41.87	---	68.20	26.33	500.0	100.0	H	110.0	-7.4
1721.000000	---	33.02	54.00	20.98	500.0	200.0	H	309.0	-4.8
1808.500000	45.34	---	68.20	22.86	500.0	200.0	V	343.0	-4.4
2499.750000	---	41.94	54.00	12.06	500.0	200.0	V	199.0	-1.2
2613.500000	47.95	---	68.20	20.25	500.0	100.0	V	272.0	-0.6
2875.125000	---	43.61	54.00	10.39	500.0	200.0	V	165.0	0.2
3371.250000	50.37	---	68.20	17.83	500.0	100.0	V	272.0	2.2
4428.250000	51.38	---	68.20	16.82	500.0	200.0	V	43.0	5.2
5000.500000	---	40.44	54.00	13.56	500.0	200.0	V	86.0	6.5
7065.500000	54.22	---	68.20	13.98	500.0	200.0	H	269.0	8.9
7531.875000	---	42.00	54.00	12.00	500.0	100.0	H	212.0	8.8

Remark: 1. Correction Factor = Antenna factor + Insertion loss (cable loss + amplifier gain)

2. Margin = Limit - MAX Peak/ Average

802.11a CH60

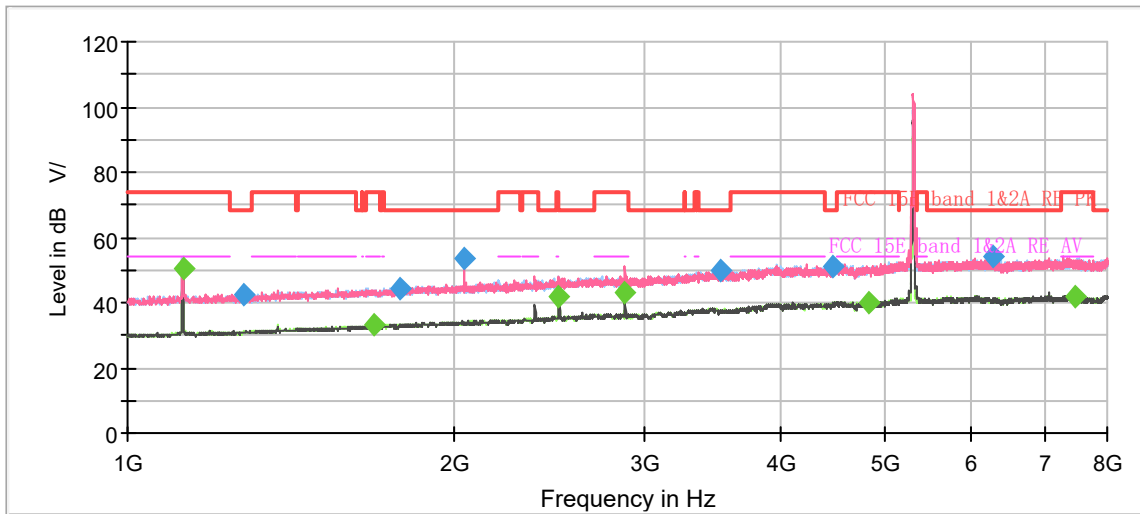

Radiates Emission from 1GHz to 8GHz
 Note: The signal beyond the limit is carrier.

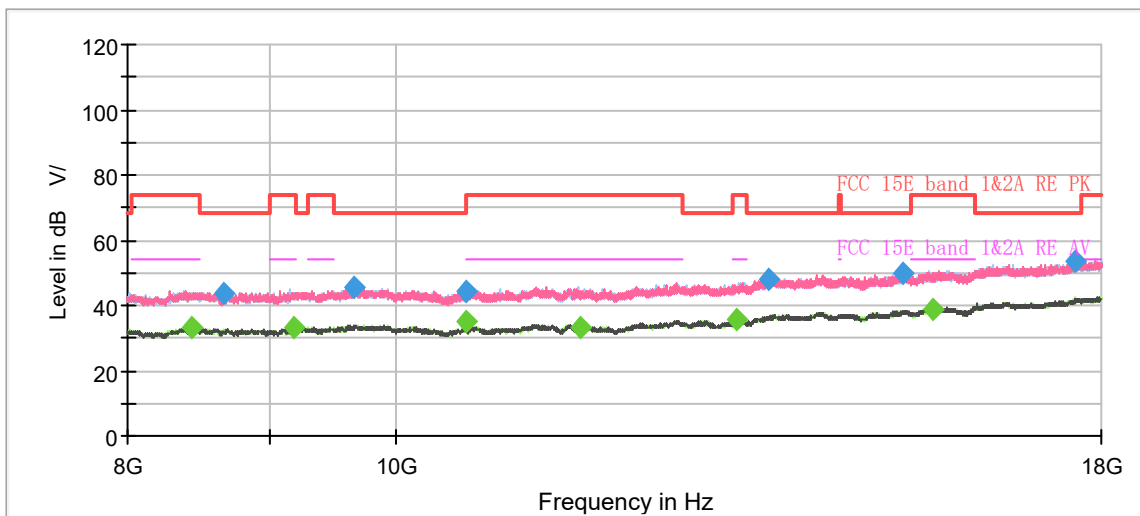

Radiates Emission from 8GHz to 18GHz

Frequency (MHz)	MaxPeak (dB μ V/m)	Average (dB μ V/m)	Limit (dB μ V/m)	Margin (dB)	Meas. Time (ms)	Height (cm)	Pol	Azimuth (deg)	Corr. (dB/m)
1124.250000	---	50.32	54.00	3.68	500.0	200.0	H	87.0	-8.2
1277.375000	42.30	---	68.20	25.90	500.0	200.0	V	126.0	-7.3
1684.250000	---	32.94	54.00	21.06	500.0	200.0	H	93.0	-5.0
1780.500000	44.26	---	68.20	23.94	500.0	100.0	V	251.0	-4.5
2044.750000	53.63	---	68.20	14.57	500.0	200.0	V	334.0	-3.2
2499.750000	---	41.85	54.00	12.15	500.0	200.0	V	231.0	-1.2
2875.125000	---	43.37	54.00	10.63	500.0	200.0	V	162.0	0.2
3517.375000	49.68	---	68.20	18.52	500.0	100.0	V	256.0	2.6
4458.875000	50.94	---	68.20	17.26	500.0	200.0	V	96.0	5.4
4817.625000	---	39.70	54.00	14.30	500.0	100.0	H	346.0	5.8
6284.125000	54.04	---	68.20	14.16	500.0	100.0	H	107.0	8.0
7476.750000	---	41.87	54.00	12.13	500.0	200.0	V	62.0	9.0

Remark: 1. Correction Factor = Antenna factor + Insertion loss (cable loss + amplifier gain)

2. Margin = Limit –MAX Peak/ Average

802.11a CH64

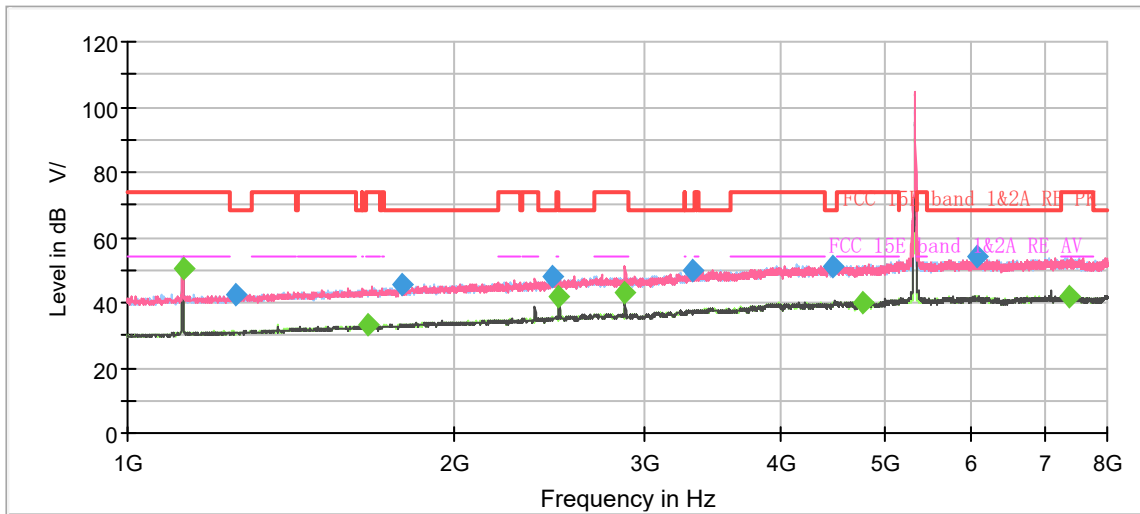

Note: The signal beyond the limit is carrier.
Radiates Emission from 1GHz to 8GHz

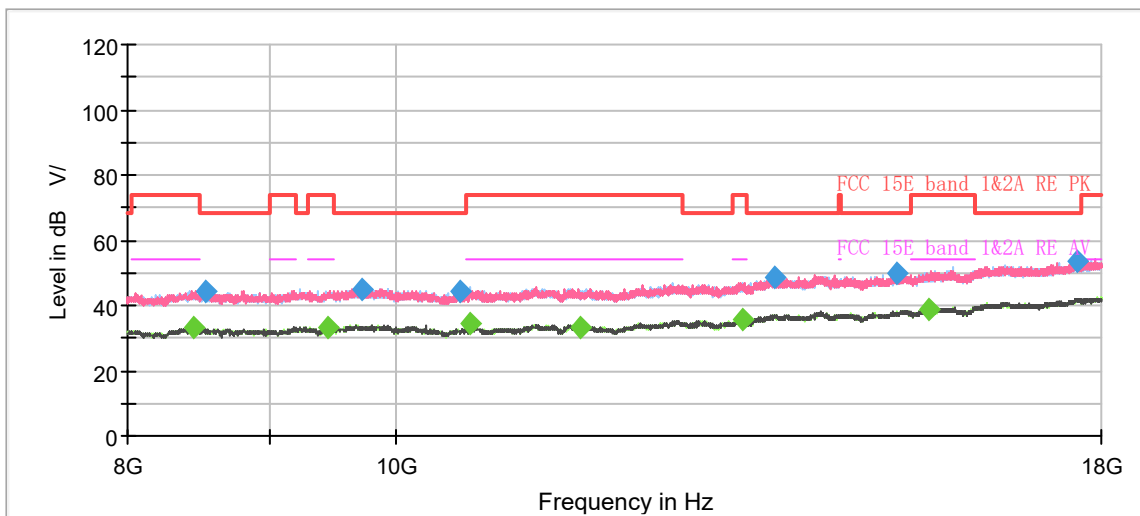

Radiates Emission from 8GHz to 18GHz

Frequency (MHz)	MaxPeak (dB μ V/m)	Average (dB μ V/m)	Limit (dB μ V/m)	Margin (dB)	Meas. Time (ms)	Height (cm)	Pol	Azimuth (deg)	Corr. (dB/m)
1124.250000	---	50.65	54.00	3.35	500.0	200.0	H	88.0	-8.2
1256.375000	42.27	---	68.20	25.93	500.0	100.0	V	245.0	-7.4
1664.125000	---	32.93	54.00	21.07	500.0	200.0	H	291.0	-5.1
1791.000000	45.63	---	68.20	22.57	500.0	200.0	V	79.0	-4.5
2464.750000	47.80	---	68.20	20.40	500.0	200.0	V	338.0	-1.3
2499.750000	---	42.09	54.00	11.91	500.0	200.0	V	256.0	-1.2
2875.125000	---	43.33	54.00	10.67	500.0	200.0	V	168.0	0.2
3317.000000	49.91	---	68.20	18.29	500.0	200.0	V	41.0	1.9
4469.375000	51.01	---	68.20	17.19	500.0	200.0	V	99.0	5.4
4756.375000	---	39.74	54.00	14.26	500.0	200.0	H	349.0	5.7
6066.250000	53.88	---	68.20	14.32	500.0	200.0	H	113.0	8.1
7391.875000	---	42.03	54.00	11.97	500.0	200.0	H	201.0	9.3

Remark: 1. Correction Factor = Antenna factor + Insertion loss (cable loss + amplifier gain)

2. Margin = Limit –MAX Peak/ Average

802.11a CH100

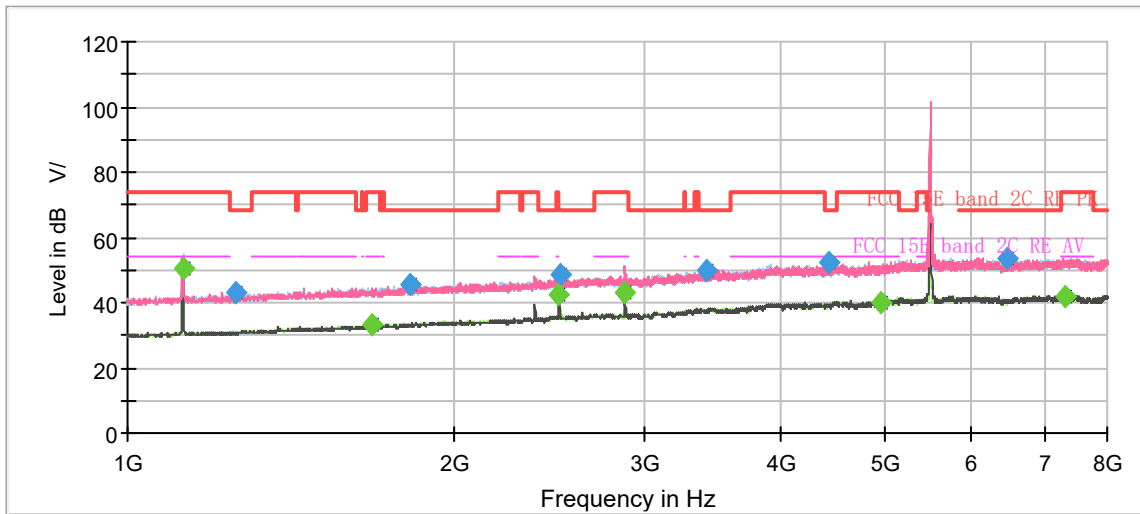

Note: The signal beyond the limit is carrier.
Radiates Emission from 1GHz to 8GHz

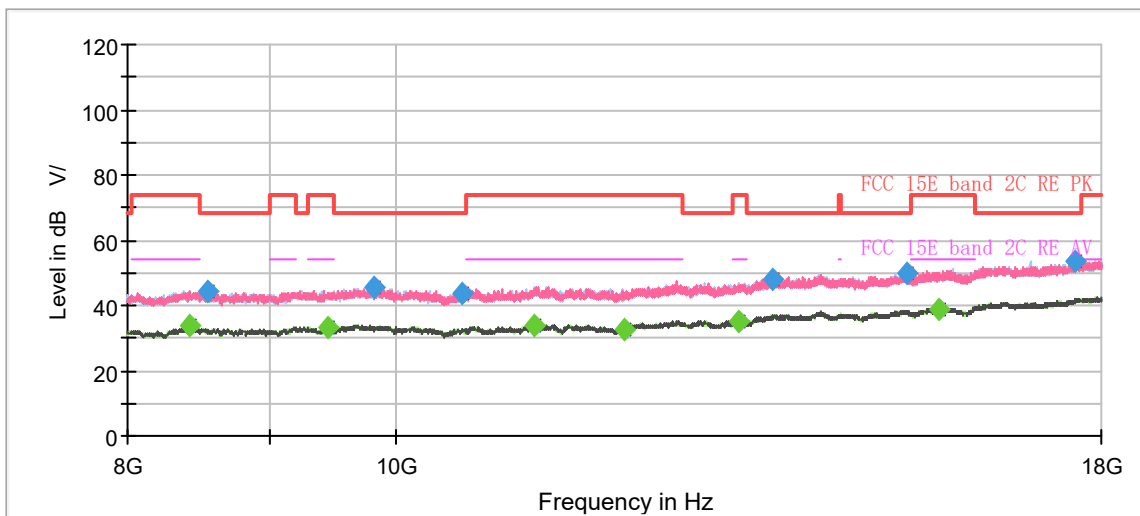

Radiates Emission from 8GHz to 18GHz

Frequency (MHz)	MaxPeak (dB μ V/m)	Average (dB μ V/m)	Limit (dB μ V/m)	Margin (dB)	Meas. Time (ms)	Height (cm)	Pol	Azimuth (deg)	Corr. (dB/m)
1124.250000	---	50.16	54.00	3.84	500.0	200.0	H	85.0	-8.2
1259.875000	43.17	---	68.20	25.03	500.0	200.0	V	0.0	-7.4
1681.625000	---	33.10	54.00	20.90	500.0	100.0	H	226.0	-5.0
1819.000000	45.78	---	68.20	22.42	500.0	200.0	H	183.0	-4.3
2499.750000	---	42.43	54.00	11.57	500.0	200.0	V	226.0	-1.2
2500.625000	48.54	---	68.20	19.66	500.0	200.0	V	236.0	-1.2
2875.125000	---	43.21	54.00	10.79	500.0	200.0	V	161.0	0.2
3416.750000	50.10	---	68.20	18.10	500.0	100.0	V	178.0	2.2
4437.875000	52.09	---	68.20	16.11	500.0	100.0	H	0.0	5.3
4947.125000	---	40.24	54.00	13.76	500.0	200.0	V	245.0	6.3
6480.125000	53.66	---	68.20	14.54	500.0	100.0	H	13.0	8.1
7307.875000	---	42.08	54.00	11.92	500.0	200.0	H	350.0	9.3

Remark: 1. Correction Factor = Antenna factor + Insertion loss (cable loss + amplifier gain)

2. Margin = Limit - MAX Peak/ Average

802.11a CH104

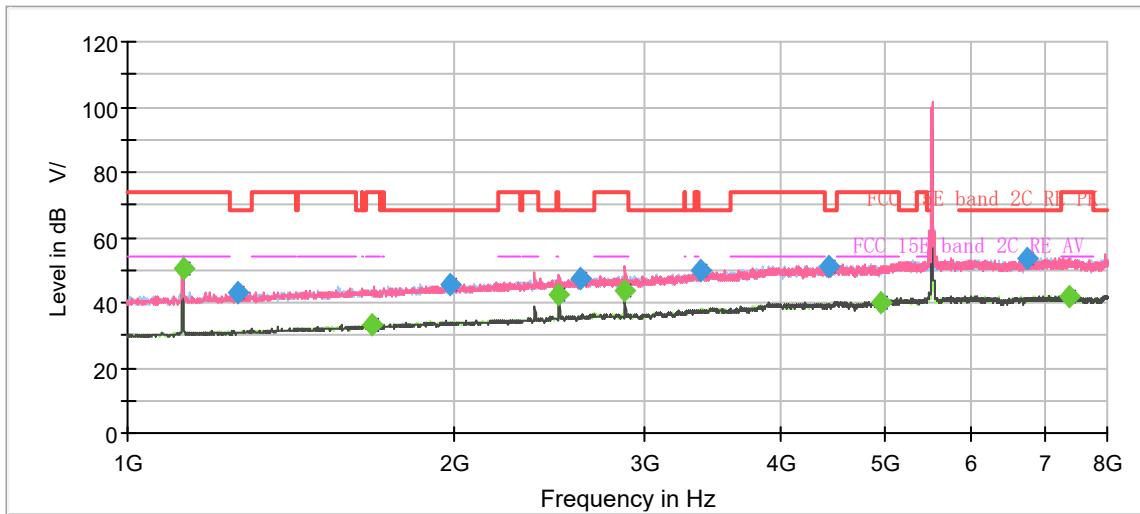

Note: The signal beyond the limit is carrier.
Radiates Emission from 1GHz to 8GHz

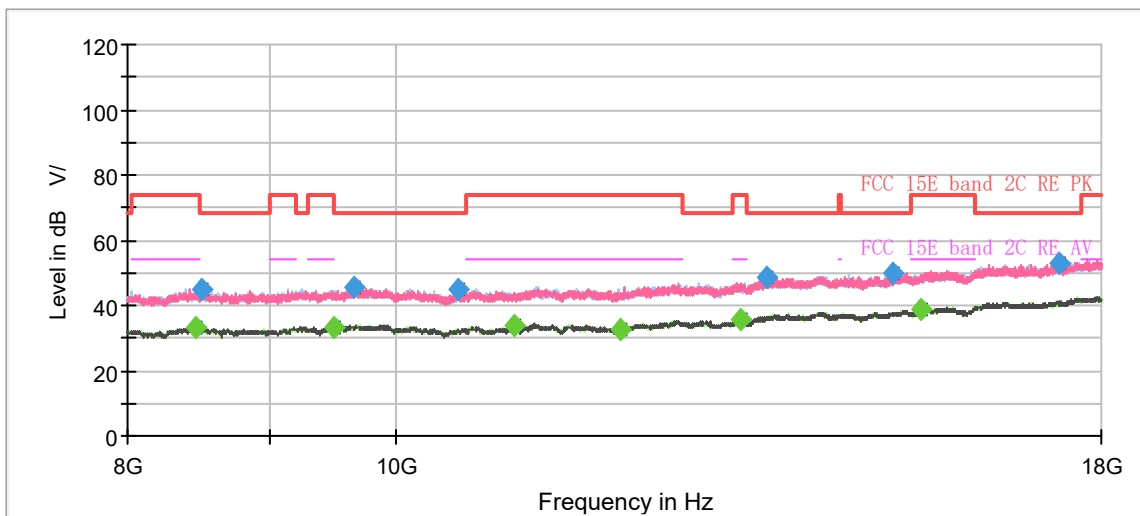

Radiates Emission from 8GHz to 18GHz

Frequency (MHz)	MaxPeak (dB μ V/m)	Average (dB μ V/m)	Limit (dB μ V/m)	Margin (dB)	Meas. Time (ms)	Height (cm)	Pol	Azimuth (deg)	Corr. (dB/m)
1124.250000	---	50.26	54.00	3.74	500.0	200.0	H	89.0	-8.2
1264.250000	42.91	---	68.20	25.29	500.0	100.0	H	171.0	-7.4
1680.750000	---	33.12	54.00	20.88	500.0	200.0	H	157.0	-5.0
1984.375000	45.84	---	68.20	22.36	500.0	200.0	H	331.0	-3.5
2499.750000	---	42.20	54.00	11.80	500.0	200.0	V	263.0	-1.2
2613.500000	47.64	---	68.20	20.56	500.0	200.0	H	340.0	-0.6
2875.125000	---	43.70	54.00	10.30	500.0	200.0	V	161.0	0.2
3377.375000	49.82	---	68.20	18.38	500.0	200.0	H	266.0	2.2
4430.000000	51.18	---	68.20	17.02	500.0	100.0	V	161.0	5.3
4948.000000	---	40.24	54.00	13.76	500.0	200.0	V	142.0	6.3
6746.125000	53.49	---	68.20	14.71	500.0	100.0	H	99.0	8.6
7377.875000	---	41.96	54.00	12.04	500.0	200.0	H	147.0	9.3

Remark: 1. Correction Factor = Antenna factor + Insertion loss (cable loss + amplifier gain)

2. Margin = Limit - MAX Peak/ Average

802.11a CH116

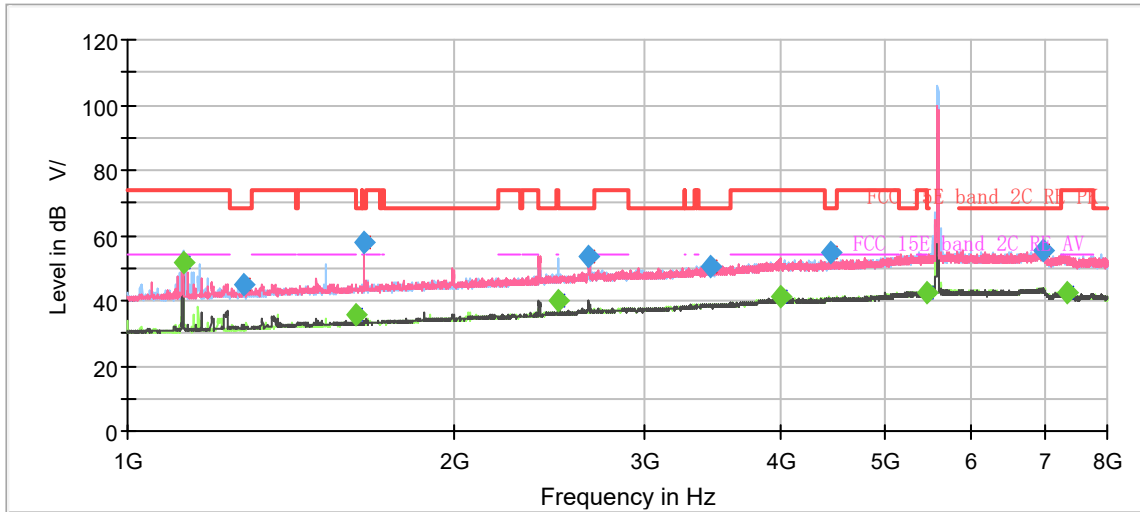

Note: The signal beyond the limit is carrier.
Radiates Emission from 1GHz to 8GHz

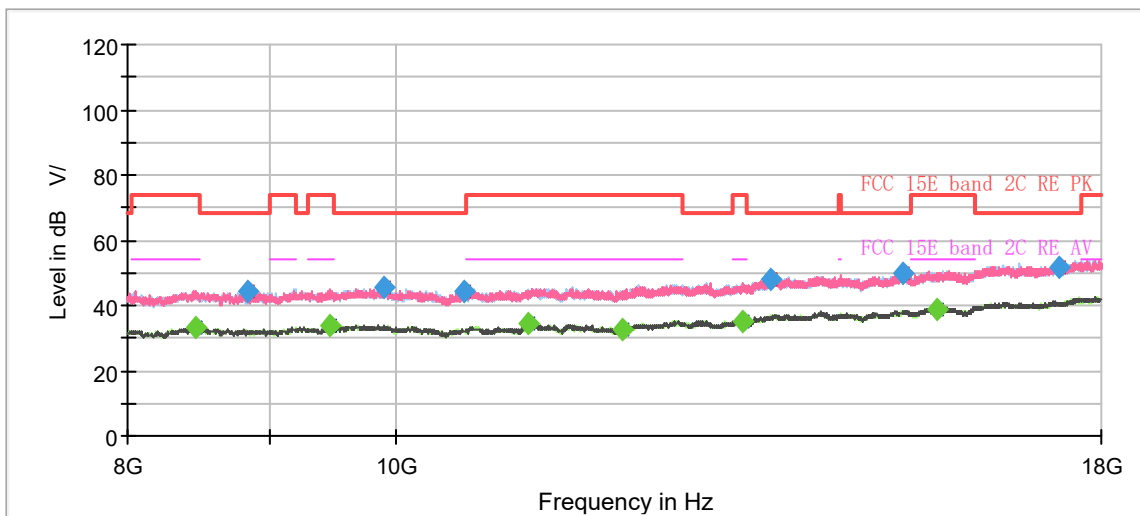

Radiates Emission from 8GHz to 18GHz

Frequency (MHz)	MaxPeak (dB μ V/m)	Average (dB μ V/m)	Limit (dB μ V/m)	Margin (dB)	Meas. Time (ms)	Height (cm)	Pol	Azimuth (deg)	Corr. (dB/m)
1124.250000	---	51.70	54.00	2.30	500.0	100.0	H	114.0	-8.2
1280.000000	44.95	---	68.20	23.25	500.0	100.0	V	295.0	-7.3
1624.750000	---	35.53	54.00	18.47	500.0	200.0	V	40.0	-5.4
1650.125000	57.68	---	68.20	10.52	500.0	200.0	V	327.0	-5.2
2499.750000	---	40.16	54.00	13.84	500.0	200.0	H	294.0	-1.2
2659.000000	53.77	---	68.20	14.43	500.0	100.0	V	285.0	-0.3
3444.750000	50.60	---	68.20	17.60	500.0	100.0	V	0.0	2.4
3999.500000	---	41.27	54.00	12.73	500.0	100.0	V	251.0	4.5
4451.875000	54.55	---	68.20	13.65	500.0	100.0	H	177.0	5.3
5459.000000	---	42.60	54.00	11.40	500.0	200.0	H	93.0	7.6
6991.125000	55.62	---	68.20	12.58	500.0	200.0	H	15.0	8.8
7341.125000	---	42.60	54.00	11.40	500.0	100.0	H	9.0	9.3

Remark: 1. Correction Factor = Antenna factor + Insertion loss (cable loss + amplifier gain)

2. Margin = Limit –MAX Peak/ Average

802.11a CH120

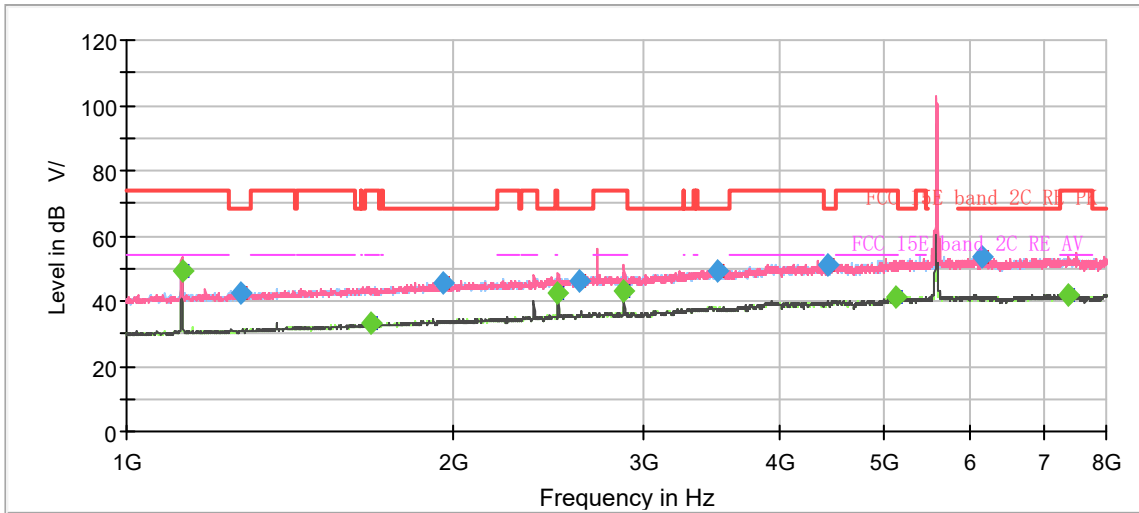

Note: The signal beyond the limit is carrier.
Radiates Emission from 1GHz to 8GHz

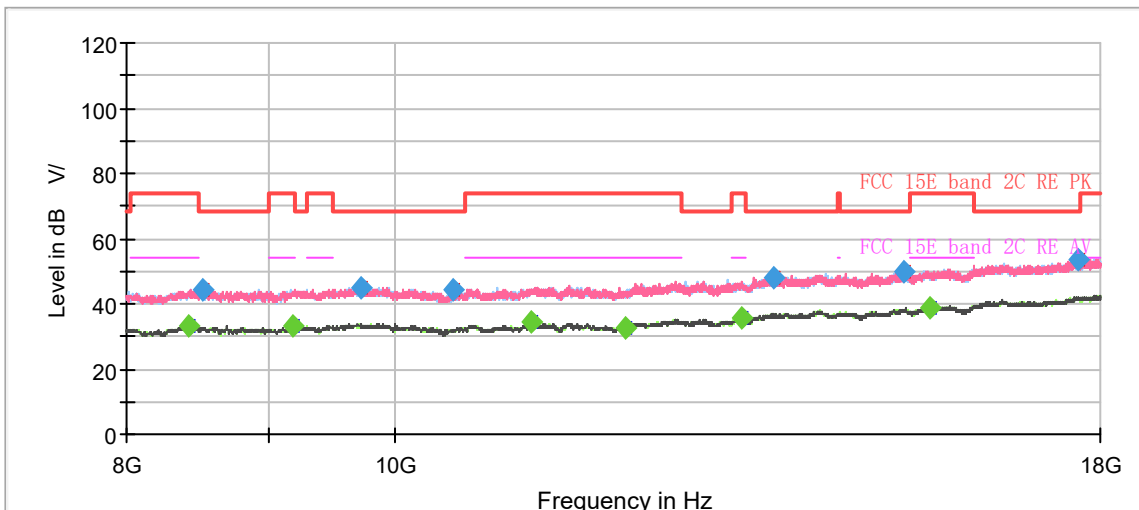

Radiates Emission from 8GHz to 18GHz

Frequency (MHz)	MaxPeak (dB μ V/m)	Average (dB μ V/m)	Limit (dB μ V/m)	Margin (dB)	Meas. Time (ms)	Height (cm)	Pol	Azimuth (deg)	Corr. (dB/m)
1124.250000	---	49.12	54.00	4.88	500.0	200.0	V	135.0	-8.2
1273.875000	42.49	---	68.20	25.71	500.0	200.0	H	187.0	-7.3
1679.875000	---	33.28	54.00	20.72	500.0	100.0	H	36.0	-5.0
1960.750000	45.72	---	68.20	22.48	500.0	200.0	V	171.0	-3.6
2499.750000	---	42.20	54.00	11.80	500.0	200.0	V	265.0	-1.2
2610.875000	46.45	---	68.20	21.75	500.0	100.0	V	39.0	-0.6
2874.250000	---	43.35	54.00	10.65	500.0	200.0	V	180.0	0.2
3511.250000	49.38	---	68.20	18.82	500.0	100.0	H	79.0	2.6
4426.500000	51.33	---	68.20	16.87	500.0	200.0	V	300.0	5.2
5117.750000	---	41.15	54.00	12.85	500.0	200.0	H	8.0	7.0
6153.750000	53.57	---	68.20	14.63	500.0	100.0	H	27.0	8.1
7376.125000	---	41.95	54.00	12.05	500.0	200.0	H	157.0	9.3

Remark: 1. Correction Factor = Antenna factor + Insertion loss (cable loss + amplifier gain)

2. Margin = Limit - MAX Peak/ Average

802.11a CH136

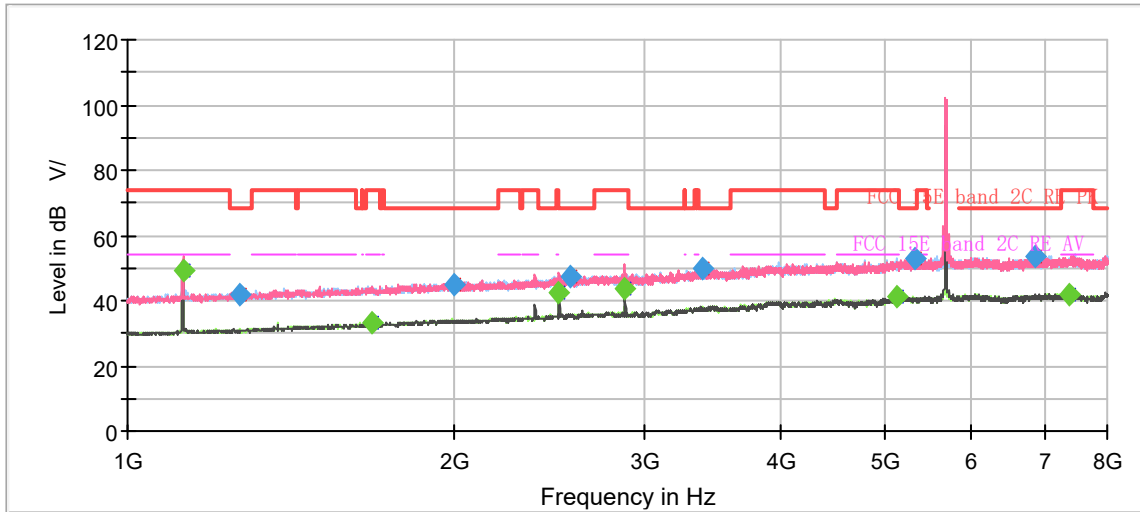

Note: The signal beyond the limit is carrier.
Radiates Emission from 1GHz to 8GHz

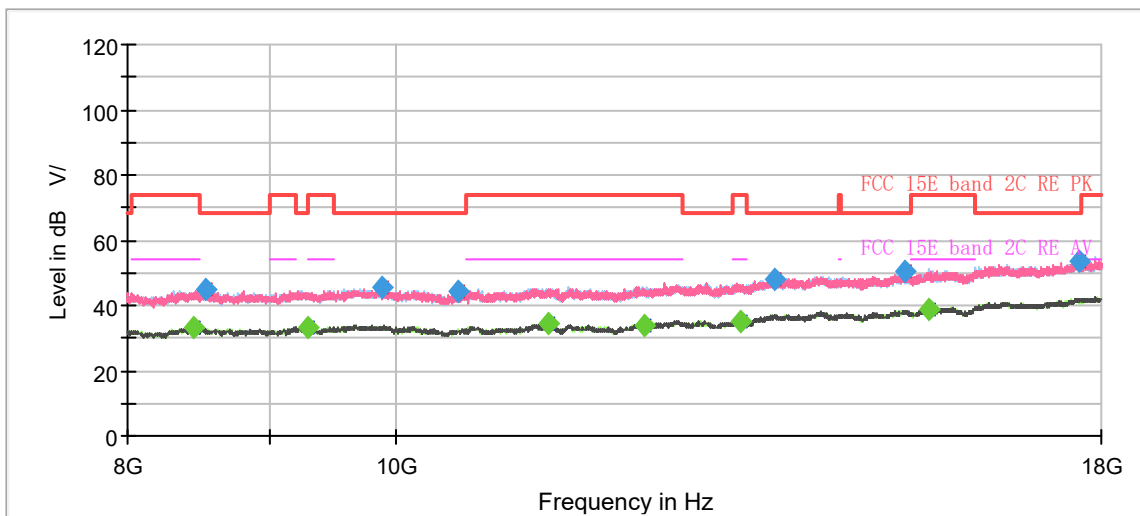

Radiates Emission from 8GHz to 18GHz

Frequency (MHz)	MaxPeak (dB μ V/m)	Average (dB μ V/m)	Limit (dB μ V/m)	Margin (dB)	Meas. Time (ms)	Height (cm)	Pol	Azimuth (deg)	Corr. (dB/m)
1124.250000	---	48.99	54.00	5.01	500.0	200.0	V	125.0	-8.2
1269.500000	41.84	---	68.20	26.36	500.0	200.0	H	153.0	-7.3
1683.375000	---	33.01	54.00	20.99	500.0	200.0	V	326.0	-5.0
1996.625000	45.23	---	68.20	22.97	500.0	100.0	H	0.0	-3.5
2499.750000	---	42.60	54.00	11.40	500.0	200.0	V	238.0	-1.2
2555.750000	47.53	---	68.20	20.67	500.0	100.0	V	177.0	-0.9
2874.250000	---	43.69	54.00	10.31	500.0	200.0	V	170.0	0.2
3388.750000	50.13	---	68.20	18.07	500.0	100.0	H	114.0	2.2
5123.000000	---	41.13	54.00	12.87	500.0	200.0	V	155.0	7.0
5319.875000	53.13	---	68.20	15.07	500.0	200.0	V	316.0	7.4
6878.250000	53.51	---	68.20	14.69	500.0	100.0	H	0.0	8.8
7387.500000	---	42.06	54.00	11.94	500.0	200.0	H	71.0	9.3

Remark: 1. Correction Factor = Antenna factor + Insertion loss (cable loss + amplifier gain)

2. Margin = Limit –MAX Peak/ Average

802.11a CH140

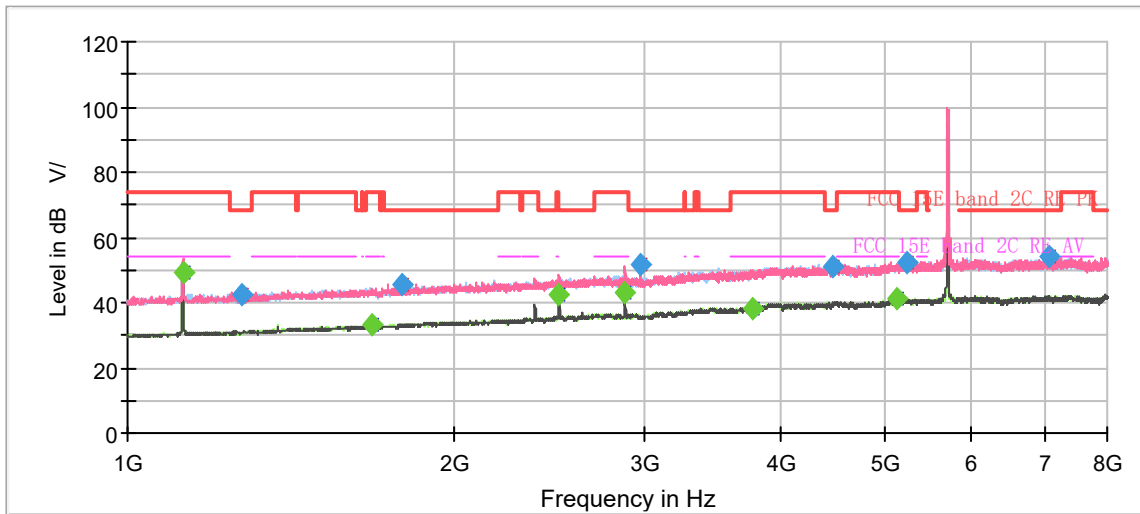

Note: The signal beyond the limit is carrier.
Radiates Emission from 1GHz to 8GHz

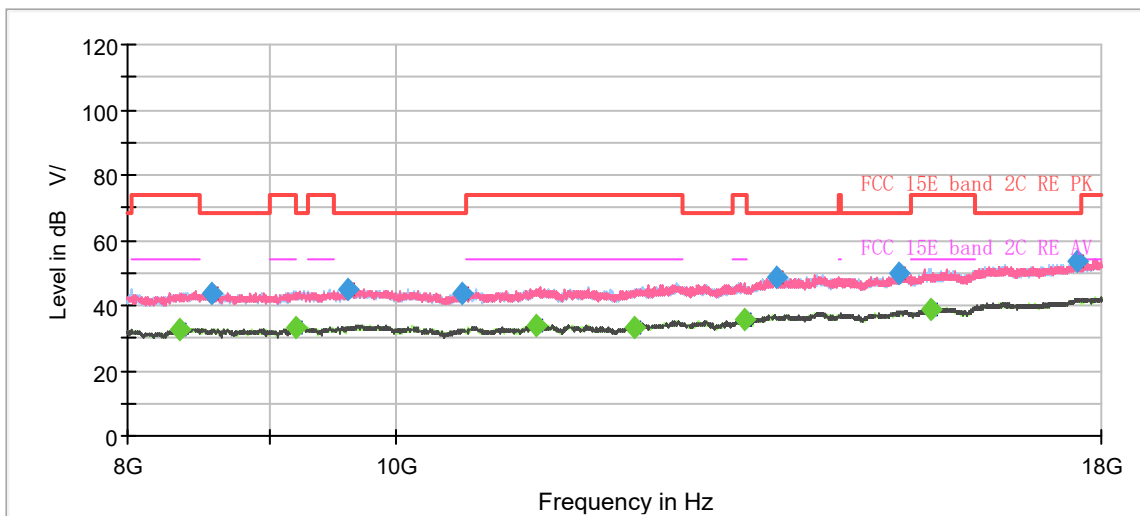

Radiates Emission from 8GHz to 18GHz

Frequency (MHz)	MaxPeak (dB μ V/m)	Average (dB μ V/m)	Limit (dB μ V/m)	Margin (dB)	Meas. Time (ms)	Height (cm)	Pol	Azimuth (deg)	Corr. (dB/m)
1124.250000	---	49.45	54.00	4.55	500.0	200.0	V	132.0	-8.2
1273.000000	42.49	---	68.20	25.71	500.0	100.0	V	31.0	-7.3
1683.375000	---	32.94	54.00	21.06	500.0	200.0	H	33.0	-5.0
1793.625000	45.41	---	68.20	22.79	500.0	200.0	V	98.0	-4.5
2499.750000	---	42.18	54.00	11.82	500.0	200.0	V	257.0	-1.2
2875.125000	---	43.22	54.00	10.78	500.0	200.0	V	171.0	0.2
2968.750000	51.47	---	68.20	16.73	500.0	200.0	V	267.0	0.4
3761.500000	---	38.29	54.00	15.71	500.0	200.0	H	87.0	3.5
4470.250000	50.86	---	68.20	17.34	500.0	200.0	V	340.0	5.4
5123.000000	---	41.10	54.00	12.90	500.0	200.0	H	53.0	7.0
5228.875000	52.41	---	68.20	15.79	500.0	200.0	H	319.0	7.3
7070.750000	53.92	---	68.20	14.28	500.0	100.0	V	159.0	8.9

Remark: 1. Correction Factor = Antenna factor + Insertion loss (cable loss + amplifier gain)

2. Margin = Limit –MAX Peak/ Average

802.11a CH144

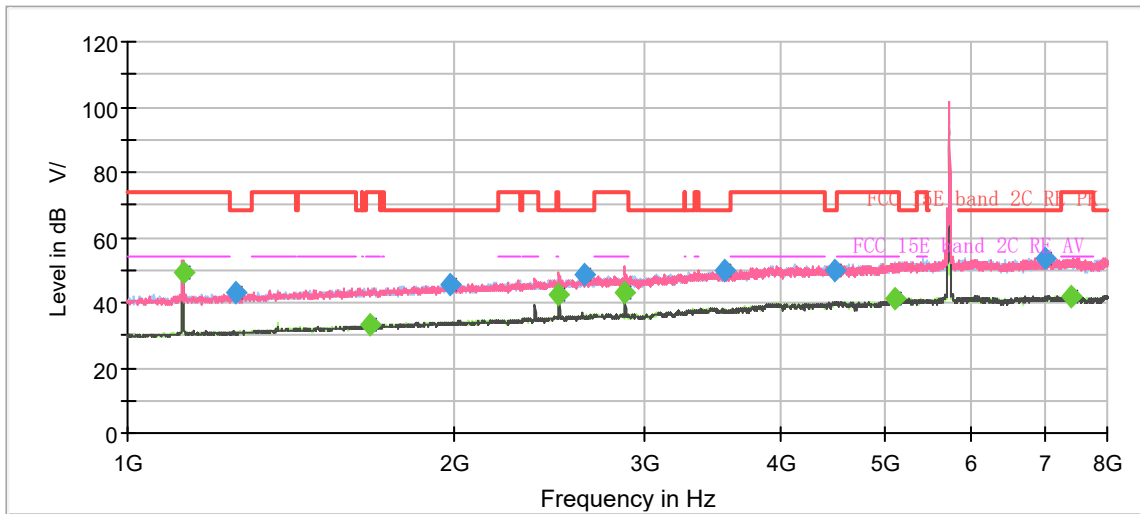

Note: The signal beyond the limit is carrier.
Radiates Emission from 1GHz to 8GHz

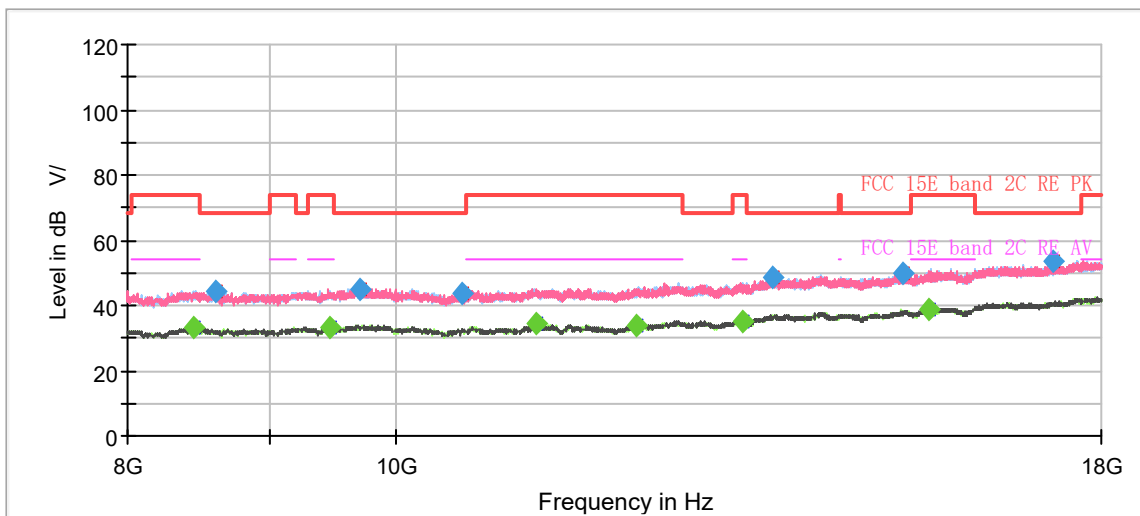

Radiates Emission from 8GHz to 18GHz

Frequency (MHz)	MaxPeak (dB μ V/m)	Average (dB μ V/m)	Limit (dB μ V/m)	Margin (dB)	Meas. Time (ms)	Height (cm)	Pol	Azimuth (deg)	Corr. (dB/m)
1124.250000	---	49.34	54.00	4.66	500.0	200.0	V	129.0	-8.2
1260.750000	42.89	---	68.20	25.31	500.0	100.0	V	47.0	-7.4
1676.375000	---	33.11	54.00	20.89	500.0	200.0	H	217.0	-5.0
1985.250000	45.48	---	68.20	22.72	500.0	200.0	V	57.0	-3.5
2499.750000	---	42.39	54.00	11.61	500.0	200.0	V	259.0	-1.2
2633.625000	48.39	---	68.20	19.81	500.0	100.0	V	88.0	-0.5
2875.125000	---	43.22	54.00	10.78	500.0	200.0	V	172.0	0.2
3552.375000	49.82	---	68.20	18.38	500.0	200.0	H	145.0	2.6
4478.125000	50.04	---	68.20	18.16	500.0	100.0	H	309.0	5.4
5092.375000	---	41.07	54.00	12.93	500.0	100.0	H	151.0	6.9
7000.750000	53.67	---	68.20	14.53	500.0	200.0	V	304.0	8.8
7410.250000	---	42.01	54.00	11.99	500.0	200.0	V	290.0	9.2

Remark: 1. Correction Factor = Antenna factor + Insertion loss (cable loss + amplifier gain)

2. Margin = Limit - MAX Peak/ Average

802.11a CH149

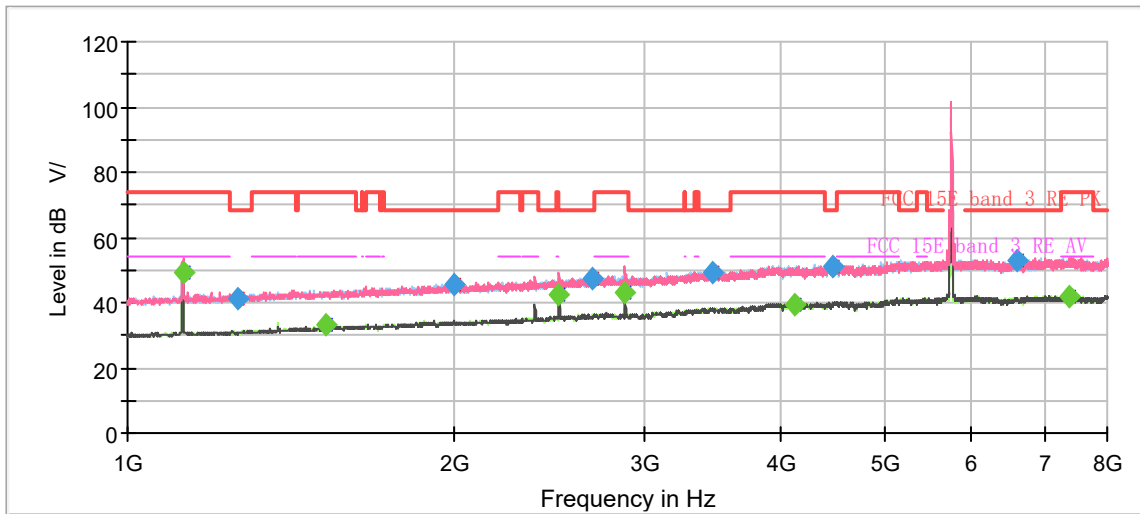

Note: The signal beyond the limit is carrier.
Radiates Emission from 1GHz to 8GHz

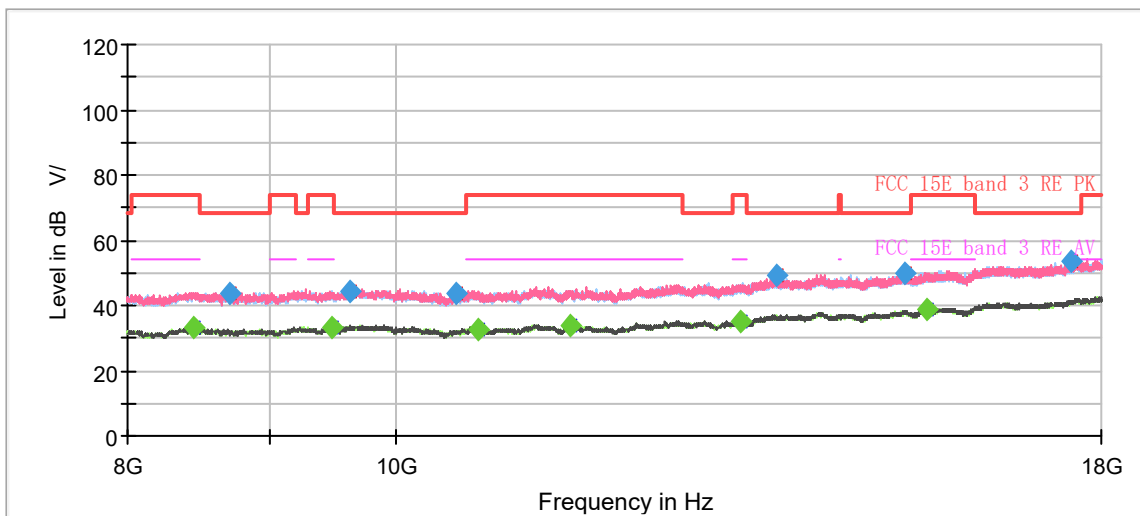

Radiates Emission from 8GHz to 18GHz

Frequency (MHz)	MaxPeak (dB μ V/m)	Average (dB μ V/m)	Limit (dB μ V/m)	Margin (dB)	Meas. Time (ms)	Height (cm)	Pol	Azimuth (deg)	Corr. (dB/m)
1124.250000	---	49.44	54.00	4.56	500.0	200.0	V	129.0	-8.2
1261.625000	41.15	---	68.20	27.05	500.0	200.0	H	45.0	-7.4
1522.375000	---	33.03	54.00	20.97	500.0	200.0	H	114.0	-5.8
1997.500000	45.45	---	68.20	22.75	500.0	100.0	H	278.0	-3.4
2499.750000	---	42.24	54.00	11.76	500.0	200.0	V	222.0	-1.2
2676.500000	47.69	---	68.20	20.51	500.0	200.0	H	193.0	-0.2
2875.125000	---	42.96	54.00	11.04	500.0	200.0	V	167.0	0.2
3464.875000	49.48	---	68.20	18.72	500.0	200.0	H	21.0	2.4
4119.375000	---	39.34	54.00	14.66	500.0	200.0	H	21.0	4.7
4466.750000	51.21	---	68.20	16.99	500.0	100.0	H	202.0	5.4
6600.000000	52.73	---	68.20	15.47	500.0	200.0	H	356.0	8.2
7385.750000	---	42.05	54.00	11.95	500.0	200.0	H	90.0	9.3

Remark: 1. Correction Factor = Antenna factor + Insertion loss (cable loss + amplifier gain)

2. Margin = Limit - MAX Peak/ Average

802.11a CH157

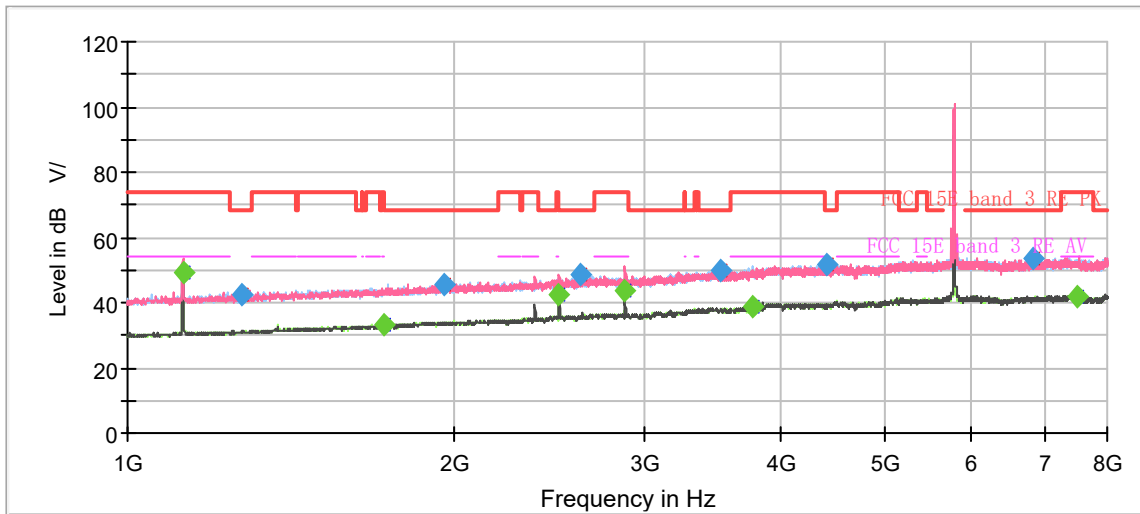

Note: The signal beyond the limit is carrier.
Radiates Emission from 1GHz to 8GHz

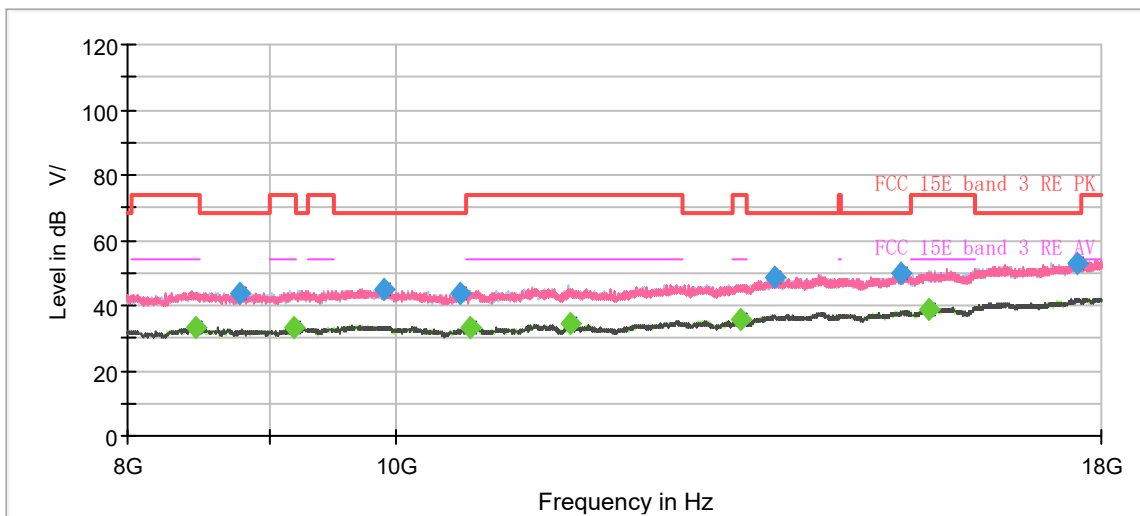

Radiates Emission from 8GHz to 18GHz

Frequency (MHz)	MaxPeak (dB μ V/m)	Average (dB μ V/m)	Limit (dB μ V/m)	Margin (dB)	Meas. Time (ms)	Height (cm)	Pol	Azimuth (deg)	Corr. (dB/m)
1124.250000	---	49.22	54.00	4.78	500.0	200.0	V	131.0	-8.2
1272.125000	42.58	---	68.20	25.62	500.0	200.0	V	170.0	-7.3
1720.125000	---	32.99	54.00	21.01	500.0	100.0	H	357.0	-4.9
1954.625000	45.56	---	68.20	22.64	500.0	100.0	V	241.0	-3.7
2499.750000	---	42.47	54.00	11.53	500.0	200.0	V	225.0	-1.2
2618.750000	48.37	---	68.20	19.83	500.0	200.0	V	289.0	-0.6
2875.125000	---	43.47	54.00	10.53	500.0	200.0	V	175.0	0.2
3523.500000	49.73	---	68.20	18.47	500.0	200.0	V	259.0	2.6
3772.875000	---	38.77	54.00	15.23	500.0	200.0	H	91.0	3.6
4420.375000	51.67	---	68.20	16.53	500.0	200.0	V	160.0	5.2
6829.250000	53.68	---	68.20	14.52	500.0	200.0	H	229.0	8.7
7505.625000	---	41.97	54.00	12.03	500.0	200.0	V	351.0	8.9

Remark: 1. Correction Factor = Antenna factor + Insertion loss (cable loss + amplifier gain)

2. Margin = Limit –MAX Peak/ Average

802.11a CH165

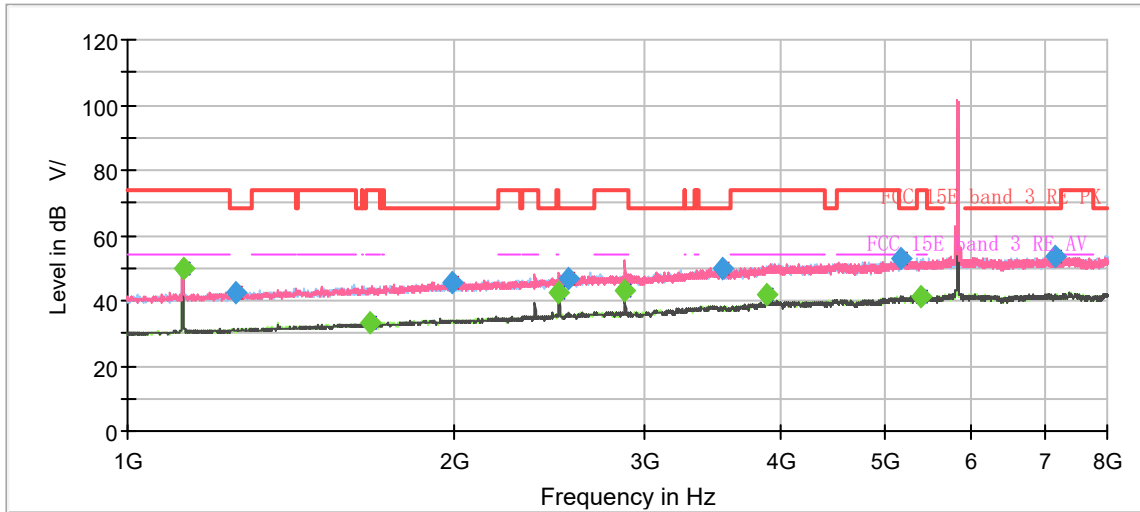

Note: The signal beyond the limit is carrier.
Radiates Emission from 1GHz to 8GHz

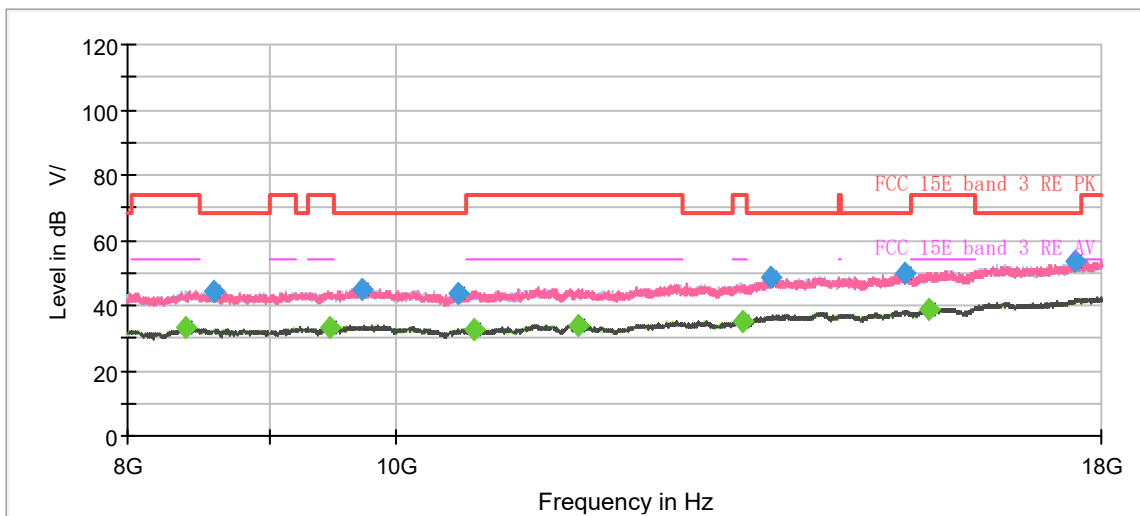

Radiates Emission from 8GHz to 18GHz

Frequency (MHz)	MaxPeak (dB μ V/m)	Average (dB μ V/m)	Limit (dB μ V/m)	Margin (dB)	Meas. Time (ms)	Height (cm)	Pol	Azimuth (deg)	Corr. (dB/m)
1124.250000	---	49.54	54.00	4.46	500.0	200.0	V	347.0	-8.2
1259.875000	42.46	---	68.20	25.74	500.0	100.0	V	275.0	-7.4
1670.250000	---	32.94	54.00	21.06	500.0	200.0	V	337.0	-5.1
1991.375000	45.61	---	68.20	22.59	500.0	200.0	V	347.0	-3.5
2499.750000	---	42.41	54.00	11.59	500.0	200.0	V	261.0	-1.2
2544.375000	46.65	---	68.20	21.55	500.0	100.0	H	313.0	-1.0
2874.250000	---	43.21	54.00	10.79	500.0	200.0	V	172.0	0.2
3534.875000	50.10	---	68.20	18.10	500.0	200.0	H	8.0	2.6
3883.125000	---	41.71	54.00	12.29	500.0	100.0	V	2.0	4.2
5165.875000	52.68	---	68.20	15.52	500.0	200.0	H	87.0	7.1
5390.750000	---	41.21	54.00	12.79	500.0	200.0	V	44.0	7.4
7171.375000	53.62	---	68.20	14.58	500.0	100.0	H	351.0	9.1

Remark: 1. Correction Factor = Antenna factor + Insertion loss (cable loss + amplifier gain)

2. Margin = Limit –MAX Peak/ Average

802.11n (HT20) CH36

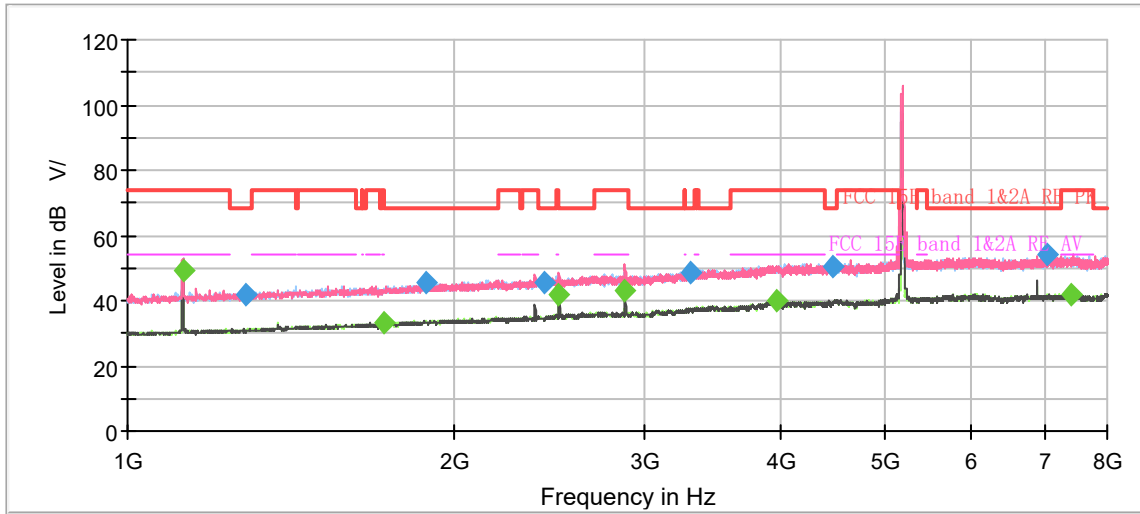

Note: The signal beyond the limit is carrier.
Radiates Emission from 1GHz to 8GHz

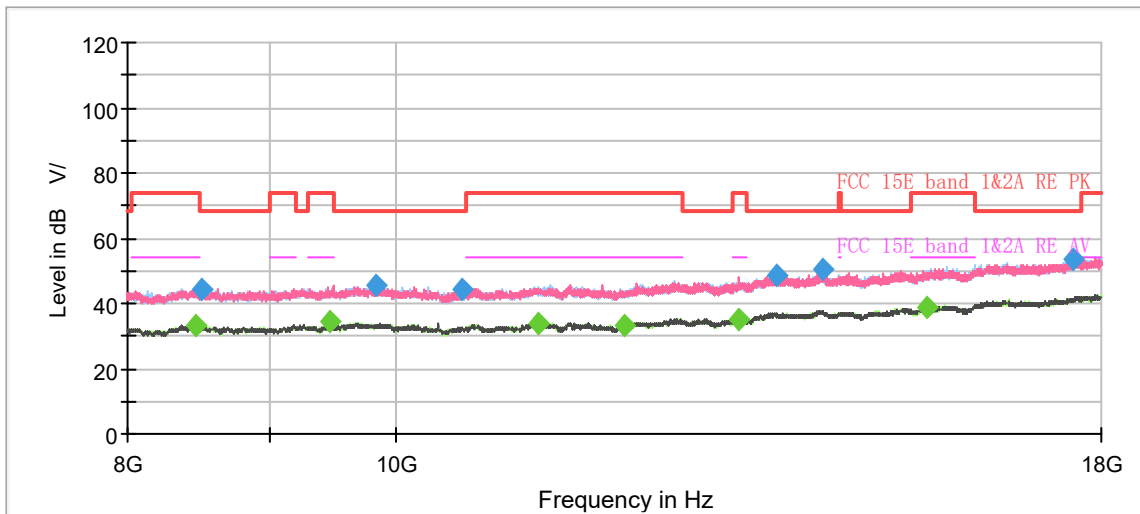

Radiates Emission from 8GHz to 18GHz

Frequency (MHz)	MaxPeak (dB μ V/m)	Average (dB μ V/m)	Limit (dB μ V/m)	Margin (dB)	Meas. Time (ms)	Height (cm)	Pol	Azimuth (deg)	Corr. (dB/m)
1124.250000	---	49.31	54.00	4.69	500.0	200.0	V	131.0	-8.2
1282.625000	41.99	---	68.20	26.21	500.0	100.0	H	337.0	-7.3
1721.000000	---	33.20	54.00	20.80	500.0	200.0	H	0.0	-4.8
1885.500000	45.42	---	68.20	22.78	500.0	100.0	V	41.0	-4.0
2424.500000	45.64	---	68.20	22.56	500.0	100.0	H	13.0	-1.5
2499.750000	---	41.96	54.00	12.04	500.0	200.0	V	269.0	-1.2
2875.125000	---	43.21	54.00	10.79	500.0	200.0	V	171.0	0.2
3309.125000	48.61	---	68.20	19.59	500.0	200.0	V	225.0	1.9
3965.375000	---	39.70	54.00	14.30	500.0	100.0	H	347.0	4.5
4469.375000	50.35	---	68.20	17.85	500.0	200.0	H	110.0	5.4
7045.375000	54.25	---	68.20	13.95	500.0	200.0	H	179.0	8.9
7398.875000	---	41.87	54.00	12.13	500.0	100.0	V	122.0	9.3

Remark: 1. Correction Factor = Antenna factor + Insertion loss (cable loss + amplifier gain)

2. Margin = Limit –MAX Peak/ Average

802.11n (HT20) CH40

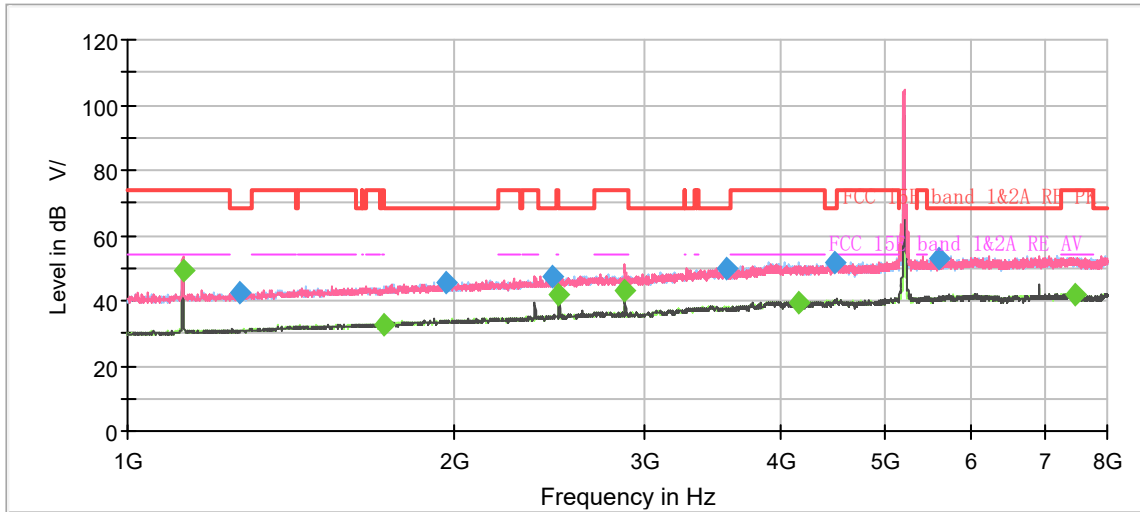

Note: The signal beyond the limit is carrier.
Radiates Emission from 1GHz to 8GHz

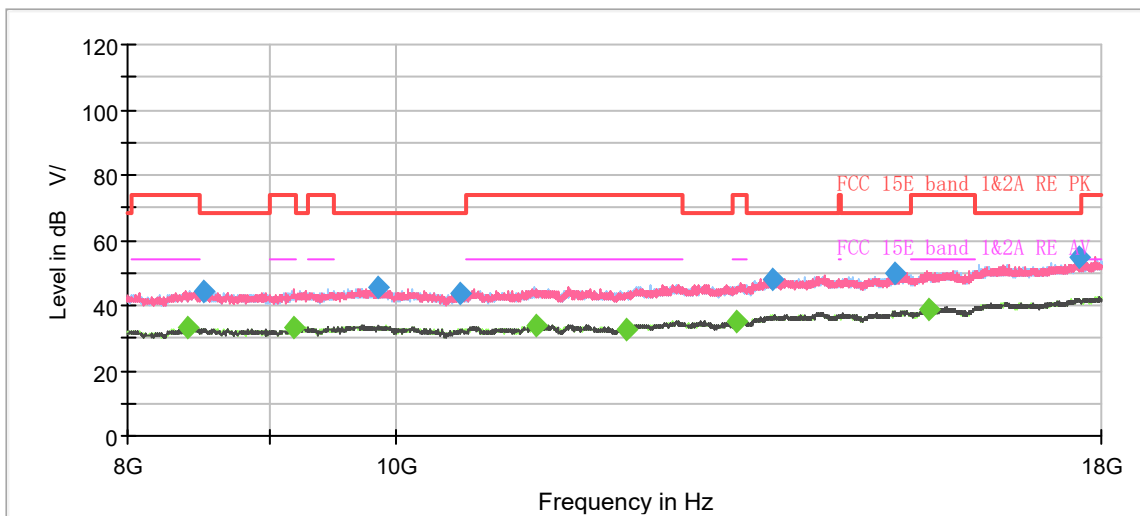

Radiates Emission from 8GHz to 18GHz

Frequency (MHz)	MaxPeak (dB μ V/m)	Average (dB μ V/m)	Limit (dB μ V/m)	Margin (dB)	Meas. Time (ms)	Height (cm)	Pol	Azimuth (deg)	Corr. (dB/m)
1124.250000	---	49.52	54.00	4.48	500.0	200.0	V	128.0	-8.2
1270.375000	42.57	---	68.20	25.63	500.0	200.0	V	270.0	-7.3
1720.125000	---	32.90	54.00	21.10	500.0	200.0	V	209.0	-4.9
1968.625000	45.60	---	68.20	22.60	500.0	100.0	H	264.0	-3.6
2460.375000	47.44	---	68.20	20.76	500.0	100.0	H	269.0	-1.3
2499.750000	---	41.99	54.00	12.01	500.0	200.0	V	232.0	-1.2
2875.125000	---	42.81	54.00	11.19	500.0	200.0	V	166.0	0.2
3562.000000	49.98	---	68.20	18.22	500.0	200.0	V	180.0	2.6
4152.625000	---	39.40	54.00	14.60	500.0	100.0	H	310.0	4.7
4480.750000	51.44	---	68.20	16.76	500.0	200.0	H	1.0	5.4
5608.625000	52.91	---	68.20	15.29	500.0	100.0	V	267.0	8.0
7482.000000	---	41.56	54.00	12.44	500.0	200.0	H	47.0	9.0

Remark: 1. Correction Factor = Antenna factor + Insertion loss (cable loss + amplifier gain)

2. Margin = Limit –MAX Peak/ Average

802.11n (HT20) CH48

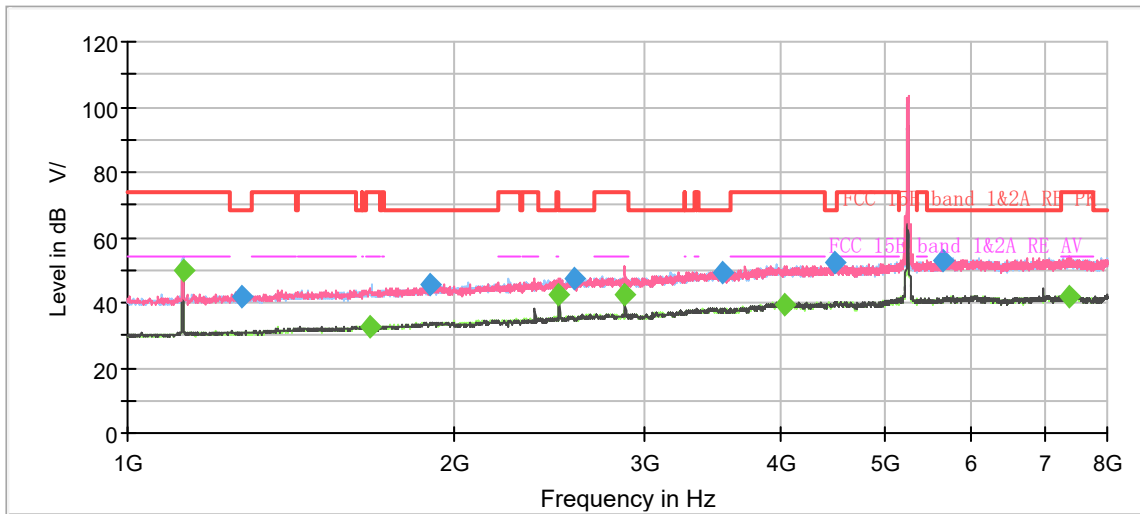

Note: The signal beyond the limit is carrier.
Radiates Emission from 1GHz to 8GHz

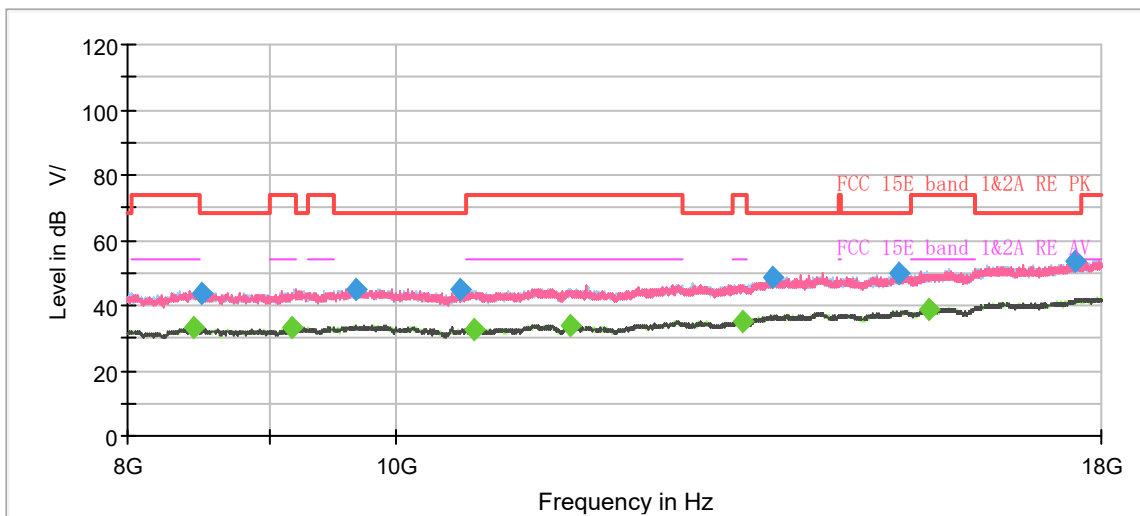

Radiates Emission from 8GHz to 18GHz

Frequency (MHz)	MaxPeak (dB μ V/m)	Average (dB μ V/m)	Limit (dB μ V/m)	Margin (dB)	Meas. Time (ms)	Height (cm)	Pol	Azimuth (deg)	Corr. (dB/m)
1124.250000	---	50.01	54.00	3.99	500.0	200.0	H	252.0	-8.2
1273.000000	41.94	---	68.20	26.26	500.0	200.0	V	110.0	-7.3
1673.750000	---	32.85	54.00	21.15	500.0	200.0	V	100.0	-5.0
1898.625000	45.46	---	68.20	22.74	500.0	100.0	V	198.0	-3.9
2499.750000	---	42.27	54.00	11.73	500.0	200.0	V	57.0	-1.2
2580.250000	47.64	---	68.20	20.56	500.0	200.0	H	285.0	-0.8
2875.125000	---	42.62	54.00	11.38	500.0	200.0	V	186.0	0.2
3533.125000	49.46	---	68.20	18.74	500.0	200.0	H	188.0	2.6
4034.500000	---	39.25	54.00	14.75	500.0	200.0	V	28.0	4.6
4485.125000	52.31	---	68.20	15.89	500.0	100.0	V	217.0	5.5
5649.750000	52.75	---	68.20	15.45	500.0	100.0	H	200.0	8.0
7391.875000	---	41.93	54.00	12.07	500.0	100.0	V	57.0	9.3

Remark: 1. Correction Factor = Antenna factor + Insertion loss (cable loss + amplifier gain)

2. Margin = Limit –MAX Peak/ Average

802.11n (HT20) CH52

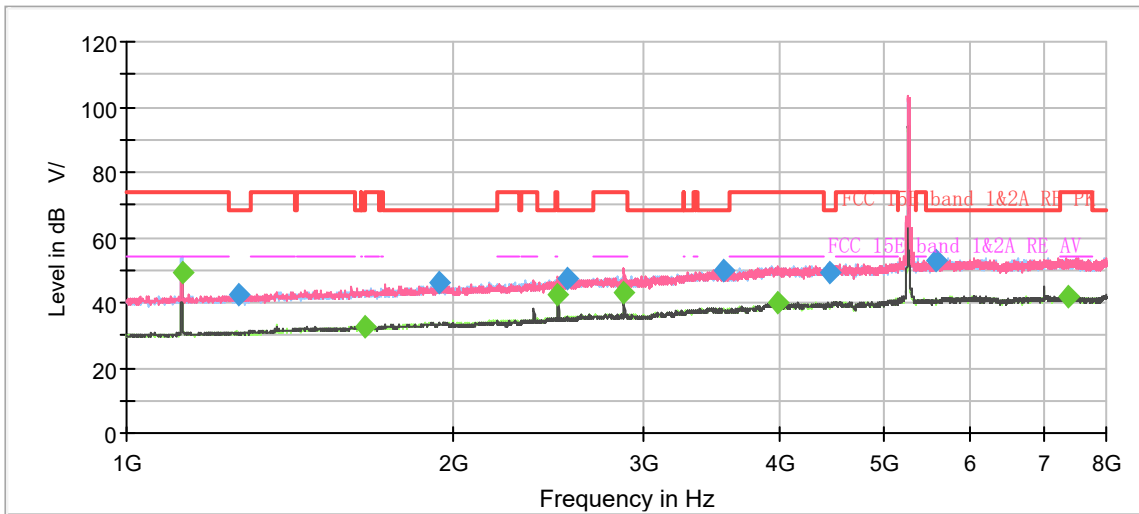

Note: The signal beyond the limit is carrier.
Radiates Emission from 1GHz to 8GHz

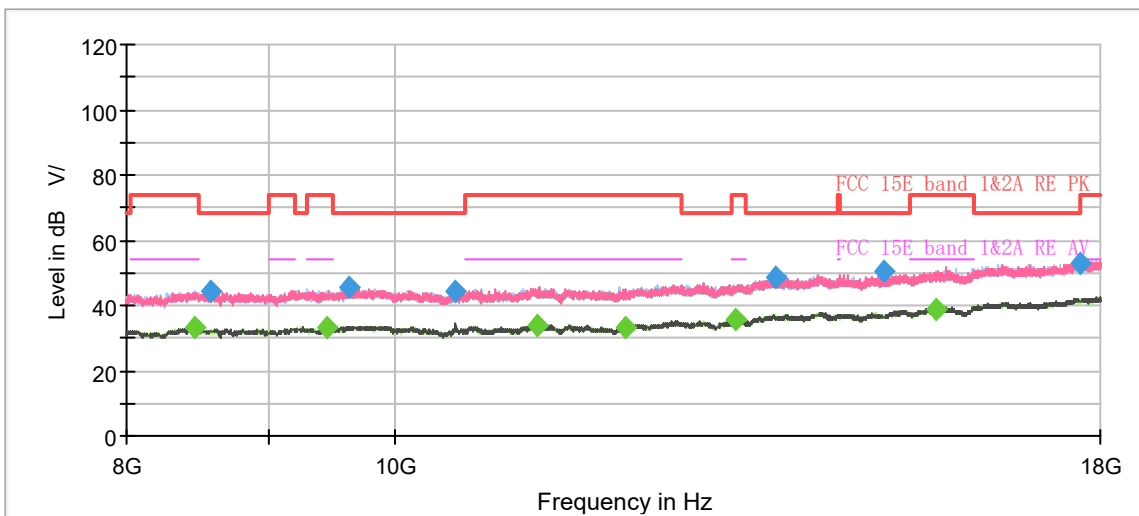

Radiates Emission from 8GHz to 18GHz

Frequency (MHz)	MaxPeak (dB μ V/m)	Average (dB μ V/m)	Limit (dB μ V/m)	Margin (dB)	Meas. Time (ms)	Height (cm)	Pol	Azimuth (deg)	Corr. (dB/m)
1124.250000	---	49.52	54.00	4.48	500.0	200.0	H	251.0	-8.2
1266.875000	42.20	---	68.20	26.00	500.0	200.0	V	51.0	-7.4
1661.500000	---	32.89	54.00	21.11	500.0	100.0	V	134.0	-5.1
1940.625000	45.85	---	68.20	22.35	500.0	100.0	H	49.0	-3.7
2499.750000	---	42.55	54.00	11.45	500.0	200.0	V	56.0	-1.2
2552.250000	47.20	---	68.20	21.00	500.0	200.0	H	256.0	-0.9
2875.125000	---	42.92	54.00	11.08	500.0	200.0	V	171.0	0.2
3550.625000	49.82	---	68.20	18.38	500.0	100.0	H	77.0	2.6
3987.250000	---	39.87	54.00	14.13	500.0	200.0	V	42.0	4.5
4439.625000	49.46	---	68.20	18.74	500.0	100.0	H	35.0	5.3
5583.250000	53.14	---	68.20	15.06	500.0	200.0	V	61.0	7.9
7376.125000	---	42.00	54.00	12.00	500.0	100.0	V	171.0	9.3

Remark: 1. Correction Factor = Antenna factor + Insertion loss (cable loss + amplifier gain)

2. Margin = Limit - MAX Peak/ Average

802.11n (HT20) CH60

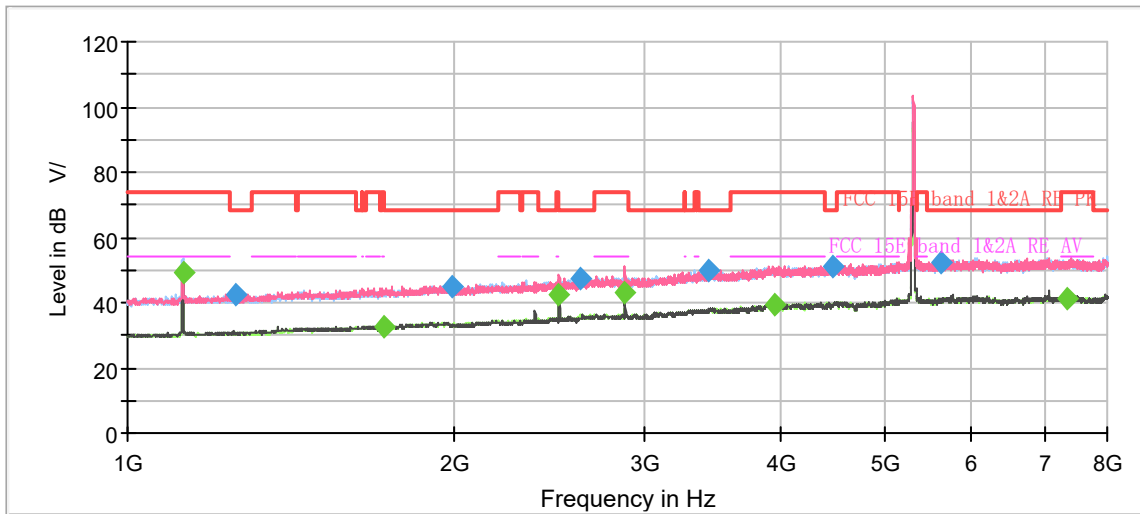

Note: The signal beyond the limit is carrier.
Radiates Emission from 1GHz to 8GHz

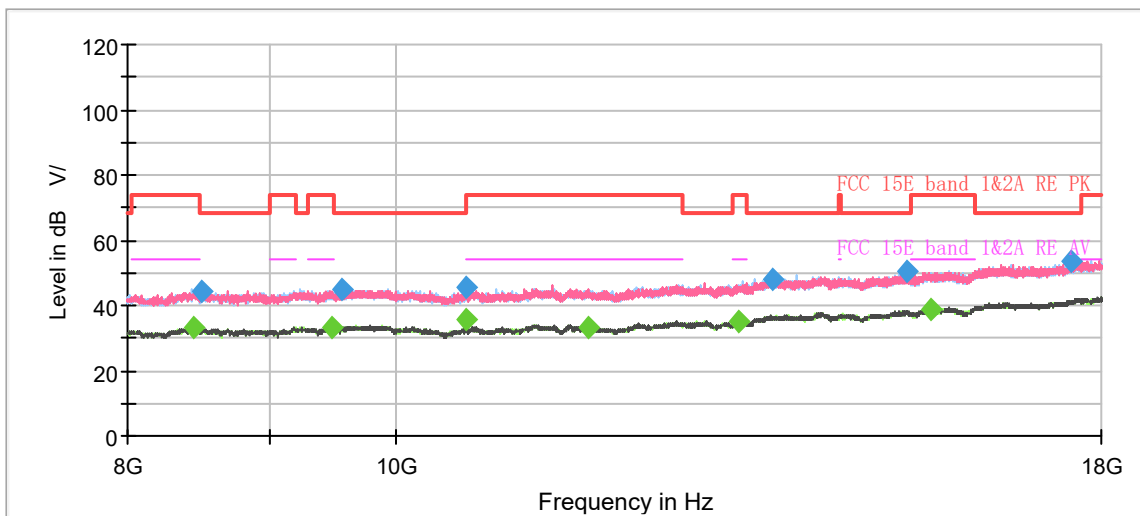

Radiates Emission from 8GHz to 18GHz