

SC206E Series

Hardware Design

Smart Module Series

Version: 1.0

Date: 2022-04-22

Status: Released



At Quectel, our aim is to provide timely and comprehensive services to our customers. If you require any assistance, please contact our headquarters:

Quectel Wireless Solutions Co., Ltd.

Building 5, Shanghai Business Park Phase III (Area B), No.1016 Tianlin Road, Minhang District, Shanghai 200233, China

Tel: +86 21 5108 6236

Email: info@quectel.com

Or our local offices. For more information, please visit:

<http://www.quectel.com/support/sales.htm>.

For technical support, or to report documentation errors, please visit:

<http://www.quectel.com/support/technical.htm>.

Or email us at: support@quectel.com.

Legal Notices

We offer information as a service to you. The provided information is based on your requirements and we make every effort to ensure its quality. You agree that you are responsible for using independent analysis and evaluation in designing intended products, and we provide reference designs for illustrative purposes only. Before using any hardware, software or service guided by this document, please read this notice carefully. Even though we employ commercially reasonable efforts to provide the best possible experience, you hereby acknowledge and agree that this document and related services hereunder are provided to you on an “as available” basis. We may revise or restate this document from time to time at our sole discretion without any prior notice to you.

Use and Disclosure Restrictions

License Agreements

Documents and information provided by us shall be kept confidential, unless specific permission is granted. They shall not be accessed or used for any purpose except as expressly provided herein.

Copyright

Our and third-party products hereunder may contain copyrighted material. Such copyrighted material shall not be copied, reproduced, distributed, merged, published, translated, or modified without prior written consent. We and the third party have exclusive rights over copyrighted material. No license shall be granted or conveyed under any patents, copyrights, trademarks, or service mark rights. To avoid ambiguities, purchasing in any form cannot be deemed as granting a license other than the normal non-exclusive, royalty-free license to use the material. We reserve the right to take legal action for noncompliance with abovementioned requirements, unauthorized use, or other illegal or malicious use of the material.

Trademarks

Except as otherwise set forth herein, nothing in this document shall be construed as conferring any rights to use any trademark, trade name or name, abbreviation, or counterfeit product thereof owned by Quectel or any third party in advertising, publicity, or other aspects.

Third-Party Rights

This document may refer to hardware, software and/or documentation owned by one or more third parties (“third-party materials”). Use of such third-party materials shall be governed by all restrictions and obligations applicable thereto.

We make no warranty or representation, either express or implied, regarding the third-party materials, including but not limited to any implied or statutory, warranties of merchantability or fitness for a particular purpose, quiet enjoyment, system integration, information accuracy, and non-infringement of any third-party intellectual property rights with regard to the licensed technology or use thereof. Nothing herein constitutes a representation or warranty by us to either develop, enhance, modify, distribute, market, sell, offer for sale, or otherwise maintain production of any our products or any other hardware, software, device, tool, information, or product. We moreover disclaim any and all warranties arising from the course of dealing or usage of trade.

Privacy Policy

To implement module functionality, certain device data are uploaded to Quectel’s or third-party’s servers, including carriers, chipset suppliers or customer-designated servers. Quectel, strictly abiding by the relevant laws and regulations, shall retain, use, disclose or otherwise process relevant data for the purpose of performing the service only or as permitted by applicable laws. Before data interaction with third parties, please be informed of their privacy and data security policy.

Disclaimer

- a) We acknowledge no liability for any injury or damage arising from the reliance upon the information.
- b) We shall bear no liability resulting from any inaccuracies or omissions, or from the use of the information contained herein.
- c) While we have made every effort to ensure that the functions and features under development are free from errors, it is possible that they could contain errors, inaccuracies, and omissions. Unless otherwise provided by valid agreement, we make no warranties of any kind, either implied or express, and exclude all liability for any loss or damage suffered in connection with the use of features and functions under development, to the maximum extent permitted by law, regardless of whether such loss or damage may have been foreseeable.
- d) We are not responsible for the accessibility, safety, accuracy, availability, legality, or completeness of information, advertising, commercial offers, products, services, and materials on third-party websites and third-party resources.

Copyright © Quectel Wireless Solutions Co., Ltd. 2022. All rights reserved.

Safety Information

The following safety precautions must be observed during all phases of operation, such as usage, service or repair of any cellular terminal or mobile incorporating the module. Manufacturers of the cellular terminal should send the following safety information to users and operating personnel and incorporate these guidelines into all manuals supplied with the product. If not so, Quectel assumes no liability for customers' failure to comply with these precautions.



Full attention must be paid to driving at all times in order to reduce the risk of an accident. Using a mobile while driving (even with a handsfree kit) causes distraction and can lead to an accident. Please comply with laws and regulations restricting the use of wireless devices while driving.



Switch off the cellular terminal or mobile before boarding an aircraft. The operation of wireless appliances in an aircraft is forbidden to prevent interference with communication systems. If there is an Airplane Mode, it should be enabled prior to boarding an aircraft. Please consult the airline staff for more restrictions on the use of wireless devices on an aircraft.



Wireless devices may cause interference on sensitive medical equipment, so please be aware of the restrictions on the use of wireless devices when in hospitals, clinics or other healthcare facilities.



Cellular terminals or mobiles operating over radio signal and cellular network cannot be guaranteed to connect in certain conditions, such as when the mobile bill is unpaid or the (U)SIM card is invalid. When emergent help is needed in such conditions, use emergency call if the device supports it. In order to make or receive a call, the cellular terminal or mobile must be switched on in a service area with adequate cellular signal strength. In an emergency, the device with emergency call function cannot be used as the only contact method considering network connection cannot be guaranteed under all circumstances.



The cellular terminal or mobile contains a transmitter and receiver. When it is ON, it receives and transmits radio frequency signals. RF interference can occur if it is used close to TV set, radio, computer or other electric equipment.



In locations with potentially explosive atmospheres, obey all posted signs to turn off wireless devices such as your phone or other cellular terminals. Areas with potentially explosive atmospheres include fuelling areas, below decks on boats, fuel or chemical transfer or storage facilities, areas where the air contains chemicals or particles such as grain, dust or metal powders, etc.

About the Document

Revision History

Version	Date	Author	Description
-	2021-11-25	Dorian MENG/ Waller GUO	Creation of the document
1.0	2022-04-22	Dorian MENG/ Waller GUO	First official release

Contents

Safety Information	3
About the Document	4
Contents	5
Table Index	8
Figure Index	10
1 Introduction	12
1.1. Special Mark.....	15
2 Product Overview	16
2.1. Frequency Bands and Functions.....	16
2.2. Key Features.....	18
2.3. Functional Diagram.....	22
2.4. EVB Kit.....	22
3 Application Interfaces	23
3.1. General Description.....	23
3.2. Pin Assignment.....	24
3.3. Pin Description.....	25
3.4. Power Supply.....	36
3.4.1. Power Supply Pins.....	36
3.4.2. Voltage Stability Requirements.....	36
3.4.3. Reference Design for Power Supply.....	37
3.5. Turn On/Off.....	38
3.5.1. Turn On with PWRKEY.....	38
3.5.2. Turn Off.....	40
3.6. VRTC.....	40
3.7. Power Output.....	41
3.8. Charging Interface.....	41
3.9. USB Interface (Type-C).....	43
3.10. UART Interfaces.....	45
3.11. (U)SIM Interfaces.....	47
3.12. SD Card Interface.....	49
3.13. GPIO Interfaces.....	51
3.14. I2C Interfaces.....	52
3.15. ADC Interface.....	53
3.16. Motor Drive Interface.....	53
3.17. LCM Interface.....	54
3.18. Flash Interface.....	56
3.19. Touch Panel Interface.....	57
3.20. Camera Interfaces.....	58
3.20.1. MIPI Design Considerations.....	61
3.21. Sensor Interface.....	62

3.22.	Audio Interfaces.....	63
3.22.1.	Reference Circuit Design for Microphone Interfaces.....	64
3.22.2.	Reference Circuit Design for Earpiece Interface	65
3.22.3.	Reference Circuit Design for Headset Interface	65
3.22.4.	Reference Circuit Design for Lineout Interface.....	66
3.22.5.	Audio Signal Design Considerations	66
3.23.	USB_BOOT	67
4	Wi-Fi/Bluetooth.....	68
4.1.	Wi-Fi.....	68
4.1.1.	Wi-Fi Performance	68
4.2.	Bluetooth.....	70
4.2.1.	Bluetooth Performance	71
5	GNSS	72
5.1.	GNSS Performance	72
5.2.	GNSS RF Design Guidelines	73
6	Antenna Interfaces.....	74
6.1.	Main Antenna and Rx-diversity Antenna Interfaces	74
6.1.1.	Operating Frequency	74
6.1.2.	Reference Design	77
6.2.	Wi-Fi/Bluetooth Antenna Interface.....	77
6.3.	GNSS Antenna Interface	78
6.3.1.	Reference Circuit Design for Passive GNSS Antenna	79
6.3.2.	Reference Circuit Design for Active GNSS Antenna	80
6.4.	RF Routing Guidelines	80
6.5.	Antenna Installation	82
6.5.1.	Antenna Requirements	82
6.5.2.	RF Connector Recommendation	83
7	Reliability, Radio and Electrical Characteristics	85
7.1.	Absolute Maximum Ratings.....	85
7.2.	Power Supply Ratings	85
7.3.	Digital I/O Characteristics.....	86
7.4.	Operating and Storage Temperatures	87
7.5.	Power Consumption	88
7.6.	Tx Power.....	94
7.7.	Rx Sensitivity	97
7.8.	ESD Protection	99
8	Mechanical Information.....	100
8.1.	Mechanical Dimensions.....	100
8.2.	Recommended Footprint.....	102
8.3.	Top and Bottom Views.....	103
9	Storage, Manufacturing & Packaging.....	104

9.1.	Storage Conditions	104
9.2.	Manufacturing and Soldering	105
9.3.	Packaging Specification	107
9.3.1.	Plastic Reel	107
9.3.2.	Packaging Process	108
10	Appendix References	109

Table Index

Table 1: Special Mark.....	15
Table 2: SC206E-CE Frequency Bands and GNSS Functions	16
Table 3: SC206E-EM Frequency Bands and GNSS Functions	17
Table 4: SC206E-NA Frequency Bands and GNSS Functions	17
Table 5: Key Features	18
Table 6: I/O Parameter Definition.....	25
Table 7: Pin Description	25
Table 8: Power Description	41
Table 9: Pin Definition of Charging Interface	42
Table 10: Pin Definition of USB Interface.....	43
Table 11: USB Trace Length Inside the Module.....	45
Table 12: Pin Definition of UART Interfaces.....	45
Table 13: Pin Definition of (U)SIM Interfaces.....	47
Table 14: Pin Definition of SD Card Interface	49
Table 15: SD Card Trace Length Inside the Module	50
Table 16: Pin Definition of GPIO Interfaces	51
Table 17: Pin Definition of I2C Interfaces.....	52
Table 18: Pin Definition of ADC Interface.....	53
Table 19: Pin Definition of Motor Drive Interface	53
Table 20: Pin Definition of LCM Interface	54
Table 21: Pin Definition of Flash Interface	56
Table 22: Pin Definition of Touch Panel Interface	57
Table 23: Pin Definition of Camera Interfaces	58
Table 24: MIPI Trace Length Inside the Module	61
Table 25: Pin Definition of Sensor Interface.....	62
Table 26: Pin Definition of Audio Interfaces	63
Table 27: Pin Definition of USB_BOOT Interface	67
Table 28: Wi-Fi Transmitting Performance.....	68
Table 29: Wi-Fi Receiving Performance.....	69
Table 30: Bluetooth Data Rate and Version.....	71
Table 31: Bluetooth Transmitting and Receiving Performance.....	71
Table 32: GNSS Performance.....	72
Table 33: Pin Definition of Main/Rx-diversity Antenna Interfaces	74
Table 34: SC206E-CE Operating Frequency	74
Table 35: SC206E-EM Operating Frequency	75
Table 36: SC206E-NA Operating Frequency	76
Table 37: Pin Definition of Wi-Fi/Bluetooth Antenna Interface	77
Table 38: Wi-Fi/Bluetooth Frequency	78
Table 39: Pin Definition of GNSS Antenna Interface	78
Table 40: GNSS Frequency	79
Table 41: Antenna Requirements.....	82

Table 42: Absolute Maximum Ratings.....	85
Table 43: Power Supply Ratings	85
Table 44: 1.8 V Digital I/O Requirements.....	86
Table 45: (U)SIM 1.8 V I/O Requirements	86
Table 46: (U)SIM 2.95 V I/O Requirements	86
Table 47: SD Card 1.8 V I/O Requirements.....	87
Table 48: SD Card 2.95 V I/O Requirements.....	87
Table 49: Operating and Storage Temperatures.....	87
Table 50: SC206E-CE Power Consumption	88
Table 51: SC206E-EM Power Consumption.....	90
Table 52: SC206E-NA Power Consumption	93
Table 53: SC206E-CE RF Tx Power	94
Table 54: SC206E-EM RF Tx Power	95
Table 55: SC206E-NA RF Tx Power	96
Table 56: SC206E-CE RF Rx Sensitivity	97
Table 57: SC206E-EM RF Rx Sensitivity.....	97
Table 58: SC206E-NA RF Rx Sensitivity.....	98
Table 59: Electrostatic Discharge Characteristics (Temperature: 25 °C, Humidity: 45 %)	99
Table 60: Recommended Thermal Profile Parameters.....	106
Table 61: Recommended Thermal Profile Parameters.....	107
Table 62: Plastic Reel Dimension Table (Unit: mm).....	108
Table 63: Related Documents.....	109
Table 64: Terms and Abbreviations	109

Figure Index

Figure 1: Functional Diagram..... 22

Figure 2: Pin Assignment (Top View) 24

Figure 3: Voltage Drop Sample 36

Figure 4: Reference Circuit for the Power Supply 37

Figure 5: Reference Circuit of Power Supply..... 37

Figure 6: Turn On the Module with Open Collector Driver..... 38

Figure 7: Turn On the Module Using Button 38

Figure 8: Turn-on Timing 39

Figure 9: Forced Turn-off Timing..... 40

Figure 10: RTC Powered by Coin Cell..... 40

Figure 11: Reference Design for Battery Charging Circuit 42

Figure 12: USB Interface Reference Design (OTG Supported) 44

Figure 13: Reference Circuit with Level Translator Chip for UART0 46

Figure 14: RS-232 Level Match Circuit for UART0..... 46

Figure 15: Reference Circuit for (U)SIM Interface with an 8-pin (U)SIM Card Connector 48

Figure 16: Reference Circuit for (U)SIM Interface with a 6-pin (U)SIM Card Connector 48

Figure 17: Reference Circuit for the SD Card Interface..... 50

Figure 18: Reference Circuit for Motor Connection 54

Figure 19: Reference Circuit Design for LCM Interface..... 55

Figure 20: Reference Design for LCM External Backlight Driving Circuit 56

Figure 21: Reference Circuit Design for the Touch Panel Interface 57

Figure 22: Reference Circuit Design for 3-Camera Applications..... 60

Figure 23: Reference Circuit Design for ECM Microphone Interface 64

Figure 24: Reference Circuit Design for MEMS Microphone Interface 64

Figure 25: Reference Circuit Design for Earpiece Interface..... 65

Figure 26: Reference Circuit Design for Headset Interface..... 65

Figure 27: Reference Circuit Design for Lineout Interface 66

Figure 28: Reference Circuit Design for Emergency Download Interface..... 67

Figure 29: Reference Circuit Design for Main and Rx-diversity Antenna Interfaces 77

Figure 30: Reference Circuit Design for Wi-Fi/Bluetooth Antenna 78

Figure 31: Reference Circuit Design for Passive GNSS Antenna 79

Figure 32: Reference Circuit Design for Active GNSS Antenna 80

Figure 33: Microstrip Design on a 2-layer PCB 81

Figure 34: Coplanar Waveguide Design on a 2-layer PCB 81

Figure 35: Coplanar Waveguide Design on a 4-layer PCB (Layer 3 as Reference Ground)..... 81

Figure 36: Coplanar Waveguide Design on a 4-layer PCB (Layer 4 as Reference Ground)..... 81

Figure 37: Dimensions of the U.FL-R-SMT Receptacle (Unit: mm) 83

Figure 38: Mechanicals of U.FL-LP Plugs 84

Figure 39: Space Factor of Mated Connectors (Unit: mm)..... 84

Figure 40: Module Top and Side Dimensions 100

Figure 41: Module Bottom Dimensions (Bottom View) 101

Figure 42: Recommended Footprint (Top View)	102
Figure 43: Top and Bottom Views of the Module	103
Figure 44: Recommended Reflow Soldering Thermal Profile	105
Figure 45: Carrier Tape Dimension Drawing.....	107
Figure 46: Plastic Reel Dimension Drawing	107
Figure 47: Packaging Process	108

1 Introduction

This document, describing SC206E series and its air and hardware interfaces connected to your applications, informs you of the interface specifications, electrical and mechanical details, as well as other related information of the module.

With the application notes and user guides provided separately, you can easily use the module to design and set up mobile applications.

Product Marketing Name: Quectel SC206E-NA

FCC Certification Requirements.

According to the definition of mobile and fixed device is described in Part 2.1091(b), this device is a mobile device.

And the following conditions must be met:

1. This Modular Approval is limited to OEM installation for mobile and fixed applications only. The antenna installation and operating configurations of this transmitter, including any applicable source-based timeaveraging duty factor, antenna gain and cable loss must satisfy MPE categorical Exclusion Requirements of 2.1091.
2. The EUT is a mobile device; maintain at least a 20 cm separation between the EUT and the user's body and must not transmit simultaneously with any other antenna or transmitter.
3. A label with the following statements must be attached to the host end product: This device contains FCC ID: XMR2022SC206ENA
4. To comply with FCC regulations limiting both maximum RF output power and human exposure to RF radiation, maximum antenna gain (including cable loss) must not exceed:

radiation, maximum antenna gain (including cable loss) must not exceed: Operating Band	FCC Max Antenna Gain (dBi)	IC Max Antenna Gain (dBi)
LTE BAND 2	8.00	8.00
LTE BAND 4	5.00	5.00
LTE BAND 5	9.41	6.12
LTE BAND 7	8.00	8.00
LTE BAND 12	7.62	5.64
LTE BAND 13	7.62	5.96
LTE BAND 14	7.62	6.00
LTE BAND 17	7.62	5.66
LTE BAND 25	8.00	8.00
LTE BAND 26(814-824)	9.35	NA
LTE BAND 26(824-849)	9.41	6.12

LTE BAND 41	8.00	8.00
LTE BAND 66	5.00	5.00
LTE BAND 71	7.62	5.49
BT	NA	NA
WIFI		

5. This module must not transmit simultaneously with any other antenna or transmitter

6. The host end product must include a user manual that clearly defines operating requirements and conditions that must be observed to ensure compliance with current FCC RF exposure guidelines.

For portable devices, in addition to the conditions 3 through 6 described above, a separate approval is required to satisfy the SAR requirements of FCC Part 2.1093

If the device is used for other equipment that separate approval is required for all other operating configurations, including portable configurations with respect to 2.1093 and different antenna configurations.

For this device, OEM integrators must be provided with labeling instructions of finished products.

Please refer to KDB784748 D01 v07, section 8. Page 6/7 last two paragraphs:

A certified modular has the option to use a permanently affixed label, or an electronic label. For a permanently affixed label, the module must be labeled with an FCC ID - Section 2.926 (see 2.2 Certification (labeling requirements) above). The OEM manual must provide clear instructions explaining to the OEM the labeling requirements, options and OEM user manual instructions that are required (see next paragraph).

For a host using a certified modular with a standard fixed label, if (1) the module's FCC ID is not visible when installed in the host, or (2) if the host is marketed so that end users do not have straightforward commonly used methods for access to remove the module so that the FCC ID of the module is visible; then an additional permanent label referring to the enclosed module: "Contains Transmitter Module FCC ID: XMR2022SC206ENA" or "Contains FCC ID: XMR2022SC206ENA" must be used. The host OEM user manual must also contain clear instructions on how end users can find and/or access the module and the FCC ID.

The final host / module combination may also need to be evaluated against the FCC Part 15B criteria for unintentional radiators in order to be properly authorized for operation as a Part 15 digital device.

The user's manual or instruction manual for an intentional or unintentional radiator shall caution the user that changes or modifications not expressly approved by the party responsible for compliance could void the user's authority to operate the equipment. In cases where the manual is provided only in a form other than paper, such as on a computer disk or over the Internet, the information required by this section may be included in the manual in that alternative form, provided the user can reasonably be expected to have the capability to access information in that form.

This device complies with part 15 of the FCC Rules. Operation is subject to the following two conditions:

(1) This device may not cause harmful interference, and (2) this device must accept any interference received, including interference that may cause undesired operation.

Changes or modifications not expressly approved by the manufacturer could void the user's authority to operate the equipment.

To ensure compliance with all non-transmitter functions the host manufacturer is responsible for ensuring compliance with the module(s) installed and fully operational. For example, if a host was previously authorized as an unintentional radiator under the Supplier's Declaration of Conformity procedure without a transmitter certified module and a module is added, the host manufacturer is responsible for ensuring

that the after the module is installed and operational the host continues to be compliant with the Part 15B unintentional radiator requirements.

Manual Information To the End User

The OEM integrator has to be aware not to provide information to the end user regarding how to install or remove this RF module in the user's manual of the end product which integrates this module. The end user manual shall include all required regulatory information/warning as show in this manual.

IC Statement

IRSS-GEN

"This device complies with Industry Canada's licence-exempt RSSs. Operation is subject to the following two conditions: (1) This device may not cause interference; and (2) This device must accept any interference, including interference that may cause undesired operation of the device." or "Le présent appareil est conforme aux CNR d'Industrie Canada applicables aux appareils radio exempts de licence. L'exploitation est autorisée aux deux conditions suivantes :

1) l'appareil ne doit pas produire de brouillage; 2) l'utilisateur de l'appareil doit accepter tout brouillage radioélectrique subi, même si le brouillage est susceptible d'en compromettre le fonctionnement."

Déclaration sur l'exposition aux rayonnements RF

L'autre utilisé pour l'émetteur doit être installé pour fournir une distance de séparation d'au moins 20 cm de toutes les personnes et ne doit pas être colocalisé ou fonctionner conjointement avec une autre antenne ou un autre émetteur.

The host product shall be properly labeled to identify the modules within the host product.

The Innovation, Science and Economic Development Canada certification label of a module shall be clearly visible at all times when installed in the host product; otherwise, the host product must be labeled to display the Innovation, Science and Economic Development Canada certification number for the module, preceded by the word "Contains" or similar wording expressing the same meaning, as follows: "Contains IC: 10224A- 22SC206ENA" or "where: 10224A- 22SC206ENA is the module's certification number".

Le produit hôte doit être correctement étiqueté pour identifier les modules dans le produit hôte.

L'étiquette de certification d'Innovation, Sciences et Développement économique Canada d'un module doit être clairement visible en tout temps lorsqu'il est installé dans le produit hôte; sinon, le produit hôte doit porter une étiquette indiquant le numéro de certification d'Innovation, Sciences et Développement économique Canada pour le module, précédé du mot «Contient» ou d'un libellé semblable exprimant la même signification, comme suit:

"Contient IC: 10224A- 22SC206ENA" ou "où: 10224A- 22SC206ENA est le numéro de certification du module".

i. the device for operation in the band 5150–5250 MHz is only for indoor use to reduce the potential for harmful interference to co-channel mobile satellite systems;

ii. for devices with detachable antenna(s), the maximum antenna gain permitted for devices in the bands 5250-5350 MHz and 5470-5725 MHz shall be such that the equipment still complies with the e.i.r.p. limit;

iii. for devices with detachable antenna(s), the maximum antenna gain permitted for devices in the band 5725-5850 MHz shall be such that the equipment still complies with the e.i.r.p. limits as appropriate;

iv. Omnidirectional antenna is recommended

1.1. Special Mark

Table 1: Special Mark

Mark	Definition
*	Unless otherwise specified, when an asterisk (*) is used after a function, feature, interface, pin name, AT command, or argument, it indicates that the function, feature, interface, pin, AT command, or argument is under development and currently not supported; and the asterisk (*) after a model indicates that the sample of the model is currently unavailable.

2 Product Overview

2.1. Frequency Bands and Functions

SC206E series is a series of Smart LTE modules based on Linux operating system, and provides industrial grade performance. Its general features are listed below:

- Supports worldwide LTE-FDD, LTE-TDD, DC-HSDPA, HSPA+, HSDPA, HSUPA, WCDMA, EV-DO/CDMA, EDGE and GPRS coverage.
- Supports short-range wireless communication via Wi-Fi 802.11a/b/g/n/ac and Bluetooth 5.0 ¹.
- Integrates GPS/GLONASS/BDS/Galileo/QZSS/SBAS/NavIC satellite positioning systems.
- Supports multiple audio and video codecs.
- Built-in high performance Adreno™ 702 graphics processing unit.
- Provides multiple audio and video input/output interfaces as well as abundant GPIO interfaces.

The module is available in four variants: SC206E-CE, SC206E-EM, SC206E-NA, SC206E-WF. The following tables show the supported frequency bands and network standards of the module.

Table 2: SC206E-CE Frequency Bands and GNSS Functions

Mode	Frequency Bands
LTE-FDD	B1/B3/B5/B8
LTE-TDD	B34/B38/B39/B40/B41
WCDMA	B1/B8
EV-DO/CDMA	BC0
GSM	EGSM900/DCS1800
Wi-Fi 802.11a/b/g/n/ac	2402–2482 MHz 5180–5825 MHz

¹ The module is compliant with all mandatory Bluetooth 5.0 features, but does not support Bluetooth 5.0 optional features like 2 Mbps BLE, Advanced Advertising Extension, etc.

Bluetooth 5.0	2402–2480 MHz
GNSS	GPS: 1575.42 ±1.023 MHz (L1) GLONASS: 1597.5–1605.8 MHz (L1) BDS: 1561.098 ±2 .046 MHz (B1I) Galileo: 1575.42 ±2.046 MHz (E1) QZSS: 1575.42 ±1.023 MHz (L1) SBAS: 1575.42 ±1.023 MHz (L1)

Table 3: SC206E-EM Frequency Bands and GNSS Functions

Mode	Frequency Bands
LTE-FDD	B1/B2/B3/B4/B5/B7/B8/B20/B28
LTE-TDD	B38/B40/B41
WCDMA	B1/B2/B4/B5/B8
GSM	GSM850/EGSM900/DCS1800/PCS1900
Wi-Fi 802.11a/b/g/n/ac	2402–2482 MHz 5180–5825 MHz
Bluetooth 5.0	2402–2480 MHz
GNSS	GPS: 1575.42 ±1.023 MHz (L1) GLONASS: 1597.5–1605.8 MHz (L1) BDS: 1561.098 ±2 .046 MHz (B1I) Galileo: 1575.42 ±2.046 MHz (E1) QZSS: 1575.42 ±1.023 MHz (L1) SBAS: 1575.42 ±1.023 MHz (L1)

Table 4: SC206E-NA Frequency Bands and GNSS Functions

Mode	Frequency Bands
LTE-FDD	B2/B4/B5/B7/B12/B13/B14/B17/B25/B26/B66/B71
LTE-TDD	B41
Wi-Fi 802.11a/b/g/n/ac	2402–2482 MHz 5180–5825 MHz
Bluetooth 5.0	2402–2480 MHz
GNSS	GPS:

- 1575.42 ±1.023 MHz (L1)
- 1176.45 ±10.23 MHz (L5)
- GLONASS: 1597.5–1605.8 MHz (L1)
- BDS: 1561.098 ±2 .046 MHz (B1I)
- Galileo:
 - 1575.42 ±2.046 MHz (E1)
 - 1176.45 ±10.23 MHz (E5a)
- QZSS:
 - 1575.42 ±1.023 MHz (L1)
 - 1176.45 ±10.23 MHz (L5)
- SBAS:
 - 1575.42 ±1.023 MHz (L1)
 - 1176.45 ±10.23 MHz (L5)
- NavIC: 1176.45 ±10.23 (L5)

Table 5: SC206E-WF Frequency Bands and GNSS Functions

Mode	Frequency Bands
Wi-Fi 802.11a/b/g/n/ac	2402–2482 MHz 5180–5825 MHz
Bluetooth 5.0	2402–2480 MHz

The module is a series of SMD type modules, which can be embedded into applications through its 274 pins, including 146 LCC pins and 128 LGA pins. With a compact profile of 40.5 mm × 40.5 mm × 2.85 mm, the module can meet most of the requirements for M2M applications such as edge device, edge computing, CPE, wireless POS, smart metering, router, data card, automotive, smart phone, digital signage, alarm panel, security and industry PDA, etc.

2.2. Key Features

The following table describes the detailed features of the module.

Table 5: Key Features

Feature	Details
Application Processor	<ul style="list-style-type: none"> ● 64-bit quad-core ARM Cortex-A53 microprocessor, up to 2.0 GHz ● 512 KB L2 cache
Modem DSP	<ul style="list-style-type: none"> ● Hexagon DSP v66k core

	<ul style="list-style-type: none"> ● 512 KB L2 cache
GPU	Adreno™ 702 GPU with 64-bit addressing, up to 845 MHz
Memory (Optional)	<ul style="list-style-type: none"> ● 32 GB eMMC + 2 GB LPDDR4X ● 32 GB eMMC + 3 GB LPDDR4X
Operating System	Linux*
Power Supply	<ul style="list-style-type: none"> ● Supply voltage: 3.5–4.4 V ● Typical supply voltage: 3.8 V
Transmitting Power	<ul style="list-style-type: none"> ● Class 4 (33 dBm ±2 dB) for GSM850 ● Class 4 (33 dBm ±2 dB) for EGSM900 ● Class 1 (30 dBm ±2 dB) for DCS1800 ● Class 1 (30 dBm ±2 dB) for PCS1900 ● Class E2 (27 dBm ±3 dB) for GSM850 8-PSK ● Class E2 (27 dBm ±3 dB) for EGSM900 8-PSK ● Class E2 (26 dBm ±3 dB) for DCS1800 8-PSK ● Class E2 (26 dBm ±3 dB) for PCS1900 8-PSK ● Class 3 (24 dBm +3/-1 dB) for EV-DO/CDMA BC0 ● Class 3 (24 dBm +1/-3 dB) for WCDMA bands ● Class 3 (23 dBm ±2 dB) for LTE-FDD bands ● Class 3 (23 dBm ±2 dB) for LTE-TDD bands
LTE Features	<p>SC206E-CE/EM/NA:</p> <ul style="list-style-type: none"> ● Supports 3GPP Rel-10 Cat 4 ● Supports 1.4/3/5/10/15/20 MHz RF bandwidth ● Supports Multiuser MIMO in DL direction ● Data rate (Max.): <ul style="list-style-type: none"> – Cat 4 FDD: 150 Mbps (DL)/ 50 Mbps (UL) – Cat 4 TDD: 130 Mbps (DL)/ 30 Mbps (UL)
UMTS Features	<p>SC206E-CE/EM:</p> <ul style="list-style-type: none"> ● Supports 3GPP Rel-9 DC-HSDPA, HSPA+, HSDPA, HSUPA and WCDMA ● Supports QPSK, 16QAM and 64QAM modulations ● Data rate (Max.): <ul style="list-style-type: none"> – DC-HSDPA: 42 Mbps (DL) – HSUPA: 5.76 Mbps (UL) – WCDMA: 384 kbps (DL)/ 384 kbps (UL)
CDMA2000 Features	<p>SC206E-CE:</p> <ul style="list-style-type: none"> ● Supports 3GPP2 CDMA2000 1X Advanced and 1xEV-DO Rev.A ● EV-DO: Max 3.1 Mbps (DL)/Max 1.8 Mbps (UL) ● 1X Advanced: Max 307.2 kbps (DL)/Max 307.2 kbps (UL)
GSM Features	<p>SC206E-CE/EM:</p> <p>R99</p> <ul style="list-style-type: none"> ● CSD: 9.6 kbps, 14.4 kbps <p>GPRS</p> <ul style="list-style-type: none"> ● Supports GPRS multi-slot class 33 (33 by default)

	<ul style="list-style-type: none"> ● Coding scheme: CS-1, CS-2, CS-3 and CS-4 ● Max. 107 kbps (DL), 85.6 kbps (UL) <p>EDGE</p> <ul style="list-style-type: none"> ● Supports EDGE multi-slot class 33 (33 by default) ● Supports GMSK and 8-PSK for different MCS (Modulation and Coding Scheme) ● Downlink coding schemes: MCS 1–9 ● Uplink coding schemes: MCS 1–9 ● Max. 296 kbps (DL), 236.8 kbps (UL)
WLAN Features	<ul style="list-style-type: none"> ● 2.4 GHz, 802.11b/g/n, up to 150 Mbps ● 5 GHz, 802.11a/n/ac, up to 433 Mbps ● Supports AP mode and STA mode
Bluetooth Feature ²	Bluetooth 5.0
GNSS Features ³	<p>SC206E-CE/EM:</p> <ul style="list-style-type: none"> ● GPS/GLONASS/BDS/Galileo/QZSS/SBAS, L1 <p>SC206E-NA:</p> <ul style="list-style-type: none"> ● GPS/GLONASS/BDS/Galileo/QZSS/SBAS/NavIC, L1 + L5
SMS	<ul style="list-style-type: none"> ● Text and PDU mode ● Point-to-point MO and MT ● SMS cell broadcast
LCM Interface	<ul style="list-style-type: none"> ● Supports one group of 4-lane MIPI DSI ● Supports up to HD+ (1680 × 720) @ 60 fps
Camera Interfaces	<ul style="list-style-type: none"> ● Supports two groups of 4-lane MIPI CSI, up to 2.5 Gbps/lane ● Supports two cameras (4-lane + 4-lane) or three cameras (4-lane + 2-lane + 1-lane) ● Supports up to 25 MP or 13 MP + 13 MP with dual ISP
Video Codec	<ul style="list-style-type: none"> ● Video encoding + decoding: 720P @ 30 fps + 1080P @ 30 fps ● Encoding: up to 1080P @ 30 fps; Decoding: up to 1080P @ 30 fps
Audio Interfaces	<p>Audio inputs:</p> <ul style="list-style-type: none"> ● Two differential microphone inputs ● One single-ended microphone input <p>Audio outputs:</p> <ul style="list-style-type: none"> ● Class AB stereo headphone output ● Class AB earpiece differential output ● Class AB line out differential output
Audio Codec	<ul style="list-style-type: none"> ● EVS, EVRC, EVRC-B, EVRC-WB ● G.711, G.729A, and G.729AB ● GSM-FR, GSM-EFR, GSM-HR ● AMR-NB, AMR-WB
USB Interface	<p>Type-C interface type:</p> <ul style="list-style-type: none"> ● Complies with both USB 3.1 or 2.0 specifications, with transmission rating

² The module is compliant with all mandatory Bluetooth 5.0 features, but does not support Bluetooth 5.0 optional features like 2 Mbps BLE, Advanced Advertising Extension, etc.

³ SC206E-WF does not support GNSS.

	<p>up to 5 Gbps on USB 3.1 and 480 Mbps on USB 2.0</p> <ul style="list-style-type: none"> ● Supports USB OTG ● Used for AT command communication, data transmission, software debugging, and firmware upgrade
UART Interfaces	<p>Three UART interfaces: UART0, UART1, and UART4 (debug UART)</p> <ul style="list-style-type: none"> ● UART0: four-wire UART interface supporting RTS and CTS hardware flow control ● UART1: two-wire UART interface ● UART4 (debug UART): two-wire UART interface used for debugging by default
SD Card Interface	<ul style="list-style-type: none"> ● Supports SD 3.0 ● Supports SD card hot-plug
(U)SIM Interfaces	<ul style="list-style-type: none"> ● Two (U)SIM interfaces ● Supports USIM/SIM cards: 1.8/2.95 V ● Supports Dual SIM Dual Standby (supported by default)
I2C Interfaces	<ul style="list-style-type: none"> ● Four I2C interfaces ● Used for peripherals such as camera, sensor, touch panel, etc.
ADC Interface	One generic ADC interface, up to 15-bit resolution
Real Time Clock	Supported
Antenna Interfaces	<p>SC206E-CE/EM/NA: Main antenna, Rx-diversity antenna, GNSS antenna and Wi-Fi/Bluetooth antenna interfaces</p> <p>SC206E-WF: Wi-Fi/Bluetooth antenna interface</p>
Physical Characteristics	<ul style="list-style-type: none"> ● Size: (40.5 ±0.15) mm × (40.5 ±0.15) mm × (2.85 ±0.2) mm ● Package: LCC + LGA ● Weight: Approx. 10.3 g
Temperature Range	<ul style="list-style-type: none"> ● Operating temperature range ⁴: -35 °C to +75 °C ● Storage temperature range: -40 °C to +90 °C
Firmware Upgrade	<ul style="list-style-type: none"> ● USB interface ● OTA
RoHS	All hardware components are fully compliant with EU RoHS directive.

⁴ Within operating temperature range, the module meets 3GPP specifications.

2.3. Functional Diagram

The following figure shows a block diagram of the module and illustrates the major functional parts.

- Power management
- Radio frequency
- Baseband
- LPDDR4X + eMMC flash
- Peripheral interfaces

Figure 1: Functional Diagram

2.4. EVB Kit

To help you develop applications with the module conveniently, Quectel supplies an evaluation board with accessories to control or to test the module. For details, see **document [1]**.

3 Application Interfaces

3.1. General Description

SC206E is a series of SMD type modules with 146 LCC pins and 128 LGA pins. The following interfaces and functions are described in detail in these subsequent chapters:

- Power supply
- VRTC
- Power output
- Charging interface
- USB interface
- UART interfaces
- (U)SIM interfaces
- SD card interface
- GPIO interfaces
- I2C interfaces
- ADC interface
- Motor drive interface
- LCM interface
- Flash interface
- Touch panel interface
- Camera interfaces
- Sensor interface
- Audio interfaces
- USB_BOOT Interface

3.2. Pin Assignment

The following figure shows the pin assignment of the module.

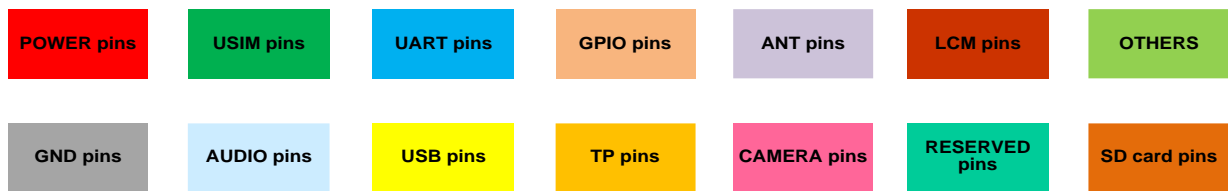
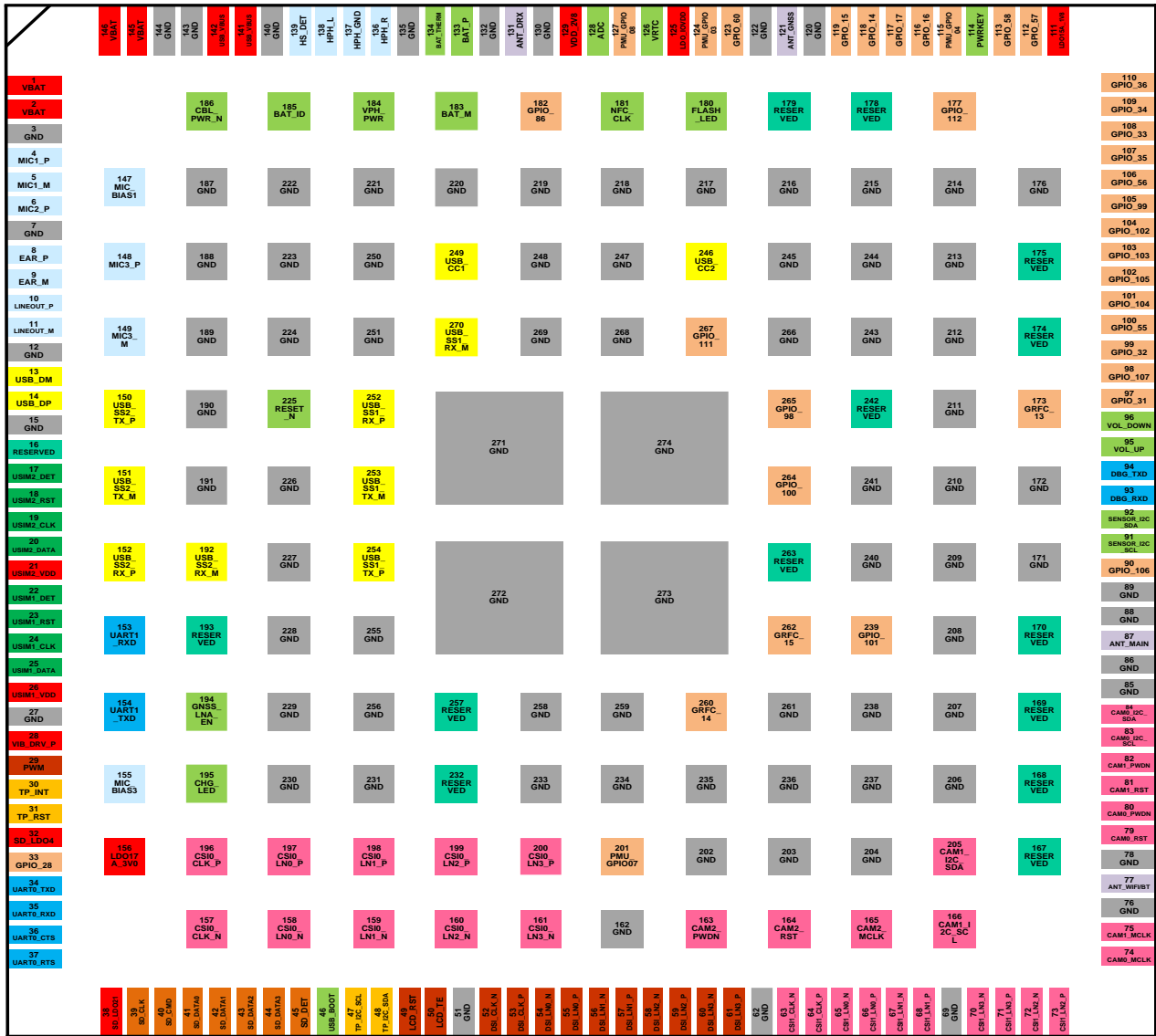

Figure 2: Pin Assignment (Top View)

3.3. Pin Description

Table 6: I/O Parameter Definition

Type	Description
AI	Analog Input
AO	Analog Output
AIO	Analog Input/Output
DI	Digital Input
DO	Digital Output
DIO	Digital Input/Output
OD	Open Drain
PI	Power Input
PO	Power Output
PIO	Power Input/Output

Table 7: Pin Description

Power Supply					
Pin Name	Pin No.	I/O	Description	DC Characteristics	Comment
VBAT	1, 2, 145, 146	PIO	Power supply for the module	Vmin = 3.5 V Vnom = 3.8 V Vmax = 4.4 V	Provide sufficient current up to 3 A. It is suggested to use a TVS for surge protection.
VPH_PWR	184	PO	Power supply for peripherals	Vmin = 3.5 V Vnom = 3.8 V Vmax = 4.4 V	This pin is used to power peripheral devices. Maximum output current is 1 A.
LDO15A_1V8	111	PO	1.8 V output	Vnom = 1.8 V Iomax = 200 mA	The power supply for LCM, sensor, cameras and I2C pull-up circuits.
LDO17A_3V0	156	PO	3.0 V output	Vnom = 3.0 V Iomax = 192 mA	The power supply for TP and sensor.

LDO_IOVDD	125	PO	1.8 V output	Vnom = 1.8 V Iomax = 300 mA	The power is reserved for LCM and camera's IOVDD. This voltage is not adjustable.
VRTC	126	PIO	Power supply for RTC	Vomax = 3.2 V Vimin = 2.5 V Vimax = 3.2 V	If unused, keep it open.
VDD_2V8	129	PO	2.8 V output	Vnom = 2.8 V Iomax = 500 mA	The power supply for camera's AVDD. This voltage is not adjustable.

Audio Interfaces

Pin Name	Pin No.	I/O	Description	DC Characteristics	Comment
MIC_BIAS1	147	PO	Bias voltage 1 output for microphone	Vomin = 1.6 V Vomax = 2.85 V	The rated output current is 3 mA.
MIC1_P	4	AI	Microphone input for channel 1 (+)		
MIC1_M	5	AI	Microphone input for channel 1 (-)		
MIC2_P	6	AI	Microphone input for headset (+)		
MIC3_P	148	AI	Microphone input for channel 3 (+)		
MIC3_M	149	AI	Microphone input for channel 3 (-)		
MIC_BIAS3	155	PO	Bias voltage 3 output for microphone	Vnom = 1.8 V	The rated output current is 3 mA. The output voltage is fixed at 1.8 V and cannot be adjusted.
EAR_P	8	AO	Earpiece output (+)		
EAR_M	9	AO	Earpiece output (-)		
LINEOUT_P	10	AO	Audio line differential output (+)		The typical output voltage is 2 Vrms.
LINEOUT_M	11	AO	Audio line differential output (-)		
HPH_R	136	AO	Headphone right channel output		
HPH_GND	137	AO	Headphone reference ground		
HPH_L	138	AO	Headphone left channel output		
HS_DET	139	AI	Headset hot-plug detect		High level by default.

USB Interface					
Pin Name	Pin No.	I/O	Description	DC Characteristics	Comment
USB_VBUS	141, 142	PIO	Charging power input.		The maximum output current is 500 mA.
			Power supply output for OTG device.	Vmax = 6.0 V	
			USB/adaptor insertion detection	Vmin = 4.0 V Vnom = 5.0 V	
USB_DM	13	AIO	USB differential data (-)		90 Ω differential impedance.
USB_DP	14	AIO	USB differential data (+)		USB 2.0 standard compliant.
USB_SS1_RX_P	252	AI	USB 3.1 channel 1 superspeed receive (+)		90 Ω differential impedance. USB 3.1 standard compliant.
USB_SS1_RX_M	270	AI	USB 3.1 channel 1 superspeed receive (-)		
USB_SS1_TX_P	254	AO	USB 3.1 channel 1 superspeed transmit (+)		
USB_SS1_TX_M	253	AO	USB 3.1 channel 1 superspeed transmit (-)		
USB_SS2_RX_P	152	AI	USB 3.1 channel 2 superspeed receive (+)		
USB_SS2_RX_M	192	AI	USB 3.1 channel 2 superspeed receive (-)		
USB_SS2_TX_P	150	AO	USB 3.1 channel 2 superspeed transmit (+)		
USB_SS2_TX_M	151	AO	USB 3.1 channel 2 superspeed transmit (-)		
USB_CC1	249	AI	USB Type-C detect 1		
USB_CC2	246	AI	USB Type-C detect 2		

(U)SIM Interfaces					
Pin Name	Pin No.	I/O	Description	DC Characteristics	Comment
USIM1_VDD	26	PO	(U)SIM1 card power supply	I _o max = 67 mA	Either 1.8 V or 2.95 V (U)SIM card is supported.
				1.8 V (U)SIM: Vmax = 1.85 V Vmin = 1.75 V	
				2.95 V (U)SIM: Vmax = 3.1 V Vmin = 2.8 V	

USIM1_DATA	25	DIO	(U)SIM1 card data	$V_{ILmax} = 0.2 \times USIM1_VDD$ $V_{IHmin} = 0.7 \times USIM1_VDD$ $V_{OLmax} = 0.4 V$ $V_{OHmin} = 0.8 \times USIM1_VDD$	Cannot be multiplexed into a generic GPIO.
USIM1_CLK	24	DO	(U)SIM1 card clock	$V_{OLmax} = 0.4 V$	
USIM1_RST	23	DO	(U)SIM1 card reset	$V_{OHmin} = 0.8 \times USIM1_VDD$	
USIM1_DET	22	DI	(U)SIM1 card hot-plug detect	$V_{ILmax} = 0.63 V$ $V_{IHmin} = 1.17 V$	Active low. Externally pull it up to 1.8 V. If unused, keep it open.
USIM2_VDD	21	PO	(U)SIM2 card power supply	$I_{omax} = 67 mA$ 1.8 V (U)SIM: $V_{max} = 1.85 V$ $V_{min} = 1.75 V$ 2.95 V (U)SIM: $V_{max} = 3.1 V$ $V_{min} = 2.8 V$	Either 1.8 V or 2.95 V (U)SIM card is supported.
USIM2_DATA	20	DIO	(U)SIM2 card data	$V_{ILmax} = 0.2 \times USIM2_VDD$ $V_{IHmin} = 0.7 \times USIM2_VDD$ $V_{OLmax} = 0.4 V$ $V_{OHmin} = 0.8 \times USIM2_VDD$	Cannot be multiplexed into a generic GPIO.
USIM2_CLK	19	DO	(U)SIM2 card clock	$V_{OLmax} = 0.4 V$	
USIM2_RST	18	DO	(U)SIM2 card reset	$V_{OHmin} = 0.8 \times USIM2_VDD$	
USIM2_DET	17	DI	(U)SIM2 card hot-plug detect	$V_{ILmax} = 0.63 V$ $V_{IHmin} = 1.17 V$	Active low. Externally pull it up to 1.8 V. If unused, keep it open.

SD Card Interface					
Pin Name	Pin No.	I/O	Description	DC Characteristics	Comment
SD_CLK	39	DO	SD card clock		
SD_CMD	40	DO	SD card command		
SD_DATA0	41	DIO	SDIO data bit 0		50 Ω characteristic impedance.
SD_DATA1	42	DIO	SDIO data bit 1		
SD_DATA2	43	DIO	SDIO data bit 2		
SD_DATA3	44	DIO	SDIO data bit 3		
SD_DET	45	DI	SD card hot-plug detect	$V_{ILmax} = 0.63 V$ $V_{IHmin} = 1.17 V$	Active low.
SD_LDO21	38	PO	SD card power supply	2.95 V/841 mA	

SD_LDO4	32	PO	1.8/2.95 V output power for SD card pull-up circuits	1.8/2.95 V 22 mA	
---------	----	----	--	---------------------	--

Touch Panel Interface

Pin Name	Pin No.	I/O	Description	DC Characteristics	Comment
TP_RST	31	DO	TP reset	$V_{OLmax} = 0.45\text{ V}$ $V_{OHmin} = 1.35\text{ V}$	1.8 V power domain. Active low.
TP_INT	30	DI	TP interrupt	$V_{ILmax} = 0.63\text{ V}$ $V_{IHmin} = 1.17\text{ V}$	1.8 V power domain.
TP_I2C_SCL	47	OD	TP I2C clock		Need to be pulled up to 1.8 V externally.
TP_I2C_SDA	48	OD	TP I2C data		Can be used for other I2C devices.

LCM Interface

Pin Name	Pin No.	I/O	Description	DC Characteristics	Comment
LCD_RST	49	DO	LCD reset	$V_{OLmax} = 0.45\text{ V}$ $V_{OHmin} = 1.35\text{ V}$	1.8 V power domain.
LCD_TE	50	DI	LCD tearing effect	$V_{ILmax} = 0.63\text{ V}$ $V_{IHmin} = 1.17\text{ V}$	
DSI_CLK_N	52	AO	LCD MIPI clock (-)		
DSI_CLK_P	53	AO	LCD MIPI clock (+)		
DSI_LN0_N	54	AO	LCD MIPI lane 0 data (-)		
DSI_LN0_P	55	AO	LCD MIPI lane 0 data (+)		
DSI_LN1_N	56	AO	LCD MIPI lane 1 data (-)		
DSI_LN1_P	57	AO	LCD MIPI lane 1 data (+)		
DSI_LN2_N	58	AO	LCD MIPI lane 2 data (-)		
DSI_LN2_P	59	AO	LCD MIPI lane 2 data (+)		
DSI_LN3_N	60	AO	LCD MIPI lane 3 data (-)		
DSI_LN3_P	61	AO	LCD MIPI lane 3 data (+)		
PWM	29	DO	PWM output		1.8 V power domain.

Camera Interfaces

Pin Name	Pin No.	I/O	Description	DC Characteristics	Comment
CSI1_CLK_N	63	AI	MIPI CSI1 clock (-)		
CSI1_CLK_P	64	AI	MIPI CSI1 clock (+)		

CSI1_LN0_N	65	AI	MIPI CSI1 lane 0 data (-)	
CSI1_LN0_P	66	AI	MIPI CSI1 lane 0 data (+)	
CSI1_LN1_N	67	AI	MIPI CSI1 lane 1 data (-)	
CSI1_LN1_P	68	AI	MIPI CSI1 lane 1 data (+)	
CSI1_LN2_N	72	AI	MIPI CSI1 lane 2 data (-)	
CSI1_LN2_P	73	AI	MIPI CSI1 lane 2 data (+)	
CSI1_LN3_N	70	AI	MIPI CSI1 lane 3 data (-)	
CSI1_LN3_P	71	AI	MIPI CSI1 lane 3 data (+)	
CSI0_CLK_N	157	AI	MIPI CSI0 clock (-)	
CSI0_CLK_P	196	AI	MIPI CSI0 clock (+)	
CSI0_LN0_N	158	AI	MIPI CSI0 lane 0 data (-)	
CSI0_LN0_P	197	AI	MIPI CSI0 lane 0 data (+)	
CSI0_LN1_N	159	AI	MIPI CSI0 lane 1 data (-)	
CSI0_LN1_P	198	AI	MIPI CSI0 lane 1 data (+)	
CSI0_LN2_N	160	AI	MIPI CSI0 lane 2 data (-)	
CSI0_LN2_P	199	AI	MIPI CSI0 lane 2 data (+)	
CSI0_LN3_N	161	AI	MIPI CSI0 lane 3 data (-)	
CSI0_LN3_P	200	AI	MIPI CSI0 lane 3 data (+)	
CAM0_I2C_SCL	83	OD	I2C clock of camera 0	Need to be pulled up to 1.8 V externally.
CAM0_I2C_SDA	84	OD	I2C data of camera 0	Can only be used for camera I2C devices.
CAM0_PWDN	80	DO	Power down of camera 0	
CAM1_PWDN	82	DO	Power down of camera 1	
CAM2_PWDN	163	DO	Power down of camera 2	$V_{OLmax} = 0.45\text{ V}$ $V_{OHmin} = 1.35\text{ V}$ 1.8 V power domain.
CAM0_MCLK	74	DO	Master clock of camera 0	
CAM1_MCLK	75	DO	Master clock of camera 1	

CAM2_MCLK	165	DO	Master clock of camera 2		
CAM0_RST	79	DO	Reset of camera 0		
CAM1_RST	81	DO	Reset of camera 1		
CAM2_RST	164	DO	Reset of camera 2		
CAM1_I2C_SCL	166	OD	I2C clock of camera 1		Need to be pulled up to 1.8 V externally.
CAM1_I2C_SDA	205	OD	I2C data of camera 1		Can only be used for camera I2C devices.

Flash & Torch Interface

Pin Name	Pin No.	I/O	Description	DC Characteristics	Comment
FLASH_LED	180	AO	Flash/torch driver output	I _o max = 1 A	Supports flash and torch modes.

Indication Interface

Pin Name	Pin No.	I/O	Description	DC Characteristics	Comment
CHG_LED	195	AI	Indicate the module's charging status	I _{max} = 5 mA	

Keypad Interfaces

Pin Name	Pin No.	I/O	Description	DC Characteristics	Comment
PWRKEY	114	DI	Turn on/off the module		Pulled up to 1.1 V internally. Active low.
VOL_UP	95	DI	Volume up	V _{IL} max = 0.63 V V _{IH} min = 1.17 V	If unused, keep it open. Cannot be externally pulled up.
VOL_DOWN	96	DI	Volume down	V _{IL} max = 0.63 V V _{IH} min = 1.17 V	1.8 V power domain.
RESET_N	225	DI	Reset the module		Disabled by default and it can be enabled via software configuration.

UART Interfaces

Pin Name	Pin No.	I/O	Description	DC Characteristics	Comment
DBG_TXD	94	DO	Debug UART transmit	V _{OL} max = 0.45 V V _{OH} min = 1.35 V	
DBG_RXD	93	DI	Debug UART receive	V _{IL} max = 0.63 V V _{IH} min = 1.17 V	1.8 V power domain.
UART0_TXD	34	DO	UART0 transmit	V _{OL} max = 0.45 V V _{OH} min = 1.35 V	If unused, keep it open.
UART0_RXD	35	DI	UART0 receive	V _{IL} max = 0.63 V V _{IH} min = 1.17 V	

UART0_RTS	37	DO	DCE request to send signal to DTE	$V_{OLmax} = 0.45\text{ V}$ $V_{OHmin} = 1.35\text{ V}$
UART0_CTS	36	DI	DCE clear to send signal from DTE	$V_{ILmax} = 0.63\text{ V}$ $V_{IHmin} = 1.17\text{ V}$
UART1_TXD	154	DO	UART1 transmit	$V_{OLmax} = 0.45\text{ V}$ $V_{OHmin} = 1.35\text{ V}$
UART1_RXD	153	DI	UART1 receive	$V_{ILmax} = 0.63\text{ V}$ $V_{IHmin} = 1.17\text{ V}$

Sensor I2C Interface

Pin Name	Pin No.	I/O	Description	DC Characteristics	Comment
SENSOR_I2C_SCL	91	OD	I2C clock for external sensor		Need to be pulled up to 1.8 V externally.
SENSOR_I2C_SDA	92	OD	I2C data for external sensor		Can only be used for sensors.

RF Antenna Interfaces

Pin Name	Pin No.	I/O	Description	DC Characteristics	Comment
ANT_MAIN	87	AIO	Main antenna interface		
ANT_GNSS	121	AI	GNSS antenna interface		
ANT_DRX	131	AI	Diversity antenna interface		50 Ω impedance.
ANT_WIFI/BT	77	AIO	Wi-Fi/Bluetooth antenna interface		

Antenna Tuner Control Interfaces

Pin Name	Pin No.	I/O	Description	DC Characteristics	Comment
GRFC_13	173	DIO	Generic RF controller		Cannot be multiplexed into a generic GPIO.
GRFC_14	260	DIO	Generic RF controller		Cannot be pulled up when the module is turning on.
GRFC_15	262	DIO	Generic RF controller		Cannot be multiplexed into a generic GPIO.

ADC Interface

Pin Name	Pin No.	I/O	Description	DC Characteristics	Comment
ADC	128	AI	General-purpose ADC interface		The maximum input voltage is 1.875 V.

Charging Interfaces

Pin Name	Pin No.	I/O	Description	DC Characteristics	Comment
BAT_P	133	AI	Battery voltage detect		Cannot be kept open.

(+)

BAT_M	183	AI	Battery voltage detect (-)		
BAT_ID	185	AI	Battery type detect	V _{imin} = 0 V V _{imax} = 1.875 V	Internally pulled down with a 100 kΩ resistor. If unused, keep it open.
BAT_THERM	134	AI	Battery temperature detect		Internally pull up by default. Supports 47 kΩ NTC thermistor by default. If unused, connect it to GND with a 47 kΩ resistor.

Vibration Motor Driver Interface

Pin Name	Pin No.	I/O	Description	DC Characteristics	Comment
VIB_DRV_P	28	PO	Vibration motor driver output control	V _{omin} = 1.5 V V _{omax} = 3.3 V I _{omax} = 100 mA	Connect it to the positive pole of the motor.

Other Interfaces

Pin Name	Pin No.	I/O	Description	DC Characteristics	Comment
USB_BOOT	46	DI	Force the module into emergency download mode		Force the module to enter emergency download mode by pulling this pin up to LDO15A_1V8 when the module is turning on.
GNSS_LNA_EN	194	DO	GNSS LNA enable control		
NFC_CLK	181	DO	NFC clock		The default output frequency is 38.4 MHz.
CBL_PWR_N	186	DI	Initiate power-on when grounded		The module cannot be turned off when this pin is pulled down. If unused, keep it open.

GPIO Interfaces

Pin Name	Pin No.	I/O	Description	DC Characteristics	Comment
GPIO_28	33	DIO	General-purpose input/output		
GPIO_31	97	DIO	General-purpose input/output		
GPIO_32	99	DIO	General-purpose		

			input/output	
GPIO_33	108	DIO	General-purpose input/output	
GPIO_34	109	DIO	General-purpose input/output	
GPIO_35	107	DIO	General-purpose input/output	
GPIO_36	110	DIO	General-purpose input/output	
GPIO_55	100	DIO	General-purpose input/output	
GPIO_56	106	DIO	General-purpose input/output	
GPIO_57	112	DIO	General-purpose input/output	Cannot be pulled up when the module is turning on.
GPIO_58	113	DIO	General-purpose input/output	
GPIO_60	123	DIO	General-purpose input/output	
GPIO_86	182	DIO	General-purpose input/output	
GPIO_112	177	DIO	General-purpose input/output	
GPIO_111	267	DIO	General-purpose input/output	
GPIO_98	265	DIO	General-purpose input/output	
GPIO_99	105	DIO	General-purpose input/output	
GPIO_100	264	DIO	General-purpose input/output	
GPIO_101	239	DIO	General-purpose input/output	
GPIO_102	104	DIO	General-purpose input/output	
GPIO_103	103	DIO	General-purpose input/output	
GPIO_104	101	DIO	General-purpose input/output	
GPIO_105	102	DIO	General-purpose input/output	
GPIO_106	90	DIO	General-purpose	

			input/output
GPIO_107	98	DIO	General-purpose input/output
GPIO_14	118	DIO	General-purpose input/output
GPIO_15	119	DIO	General-purpose input/output
GPIO_16	116	DIO	General-purpose input/output
GPIO_17	117	DIO	General-purpose input/output
PMU_GPIO03	124	DIO	General-purpose input/output
PMU_GPIO04	115	DIO	General-purpose input/output
PMU_GPIO08	127	DIO	General-purpose input/output
PMU_GPIO07	201	DIO	General-purpose input/output

GND	
Pin Name	Pin No.
GND	3, 7, 12, 15, 27, 51, 62, 69, 76, 78, 85, 86, 88, 89, 120, 122, 130, 132, 135, 140, 143, 144, 162, 171, 172, 176, 187–191, 202–204, 206–224, 226–231, 233–238, 240, 241, 243–245, 247, 248, 250, 251, 255, 256, 258, 259, 261, 266, 268, 269, 271–274

RESERVED	
Pin Name	Pin No.
RESERVED	16, 167, 168, 169, 170, 174, 175, 178, 179, 193, 232, 242, 257, 263

- NOTE**
1. Keep all RESERVED and unused pins unconnected.
 2. Connect all GND pins to ground.

3.4. Power Supply

3.4.1. Power Supply Pins

The module provides four VBAT pins for connection with external power supply.

3.4.2. Voltage Stability Requirements

The power supply range of the module is 3.5–4.4 V, and the recommended value is 3.8 V. The power supply performance, such as load capacity, voltage ripple, etc. will directly influences the module’s performance and stability. Under ultimate conditions, the transient peak current of the module may surge up to 3 A. If the power supply capacity is not sufficient, there will be the risk that the voltage drops below 3.4 V and as a result the module powers off automatically. Therefore, make sure the input voltage never drops below 3.4 V.

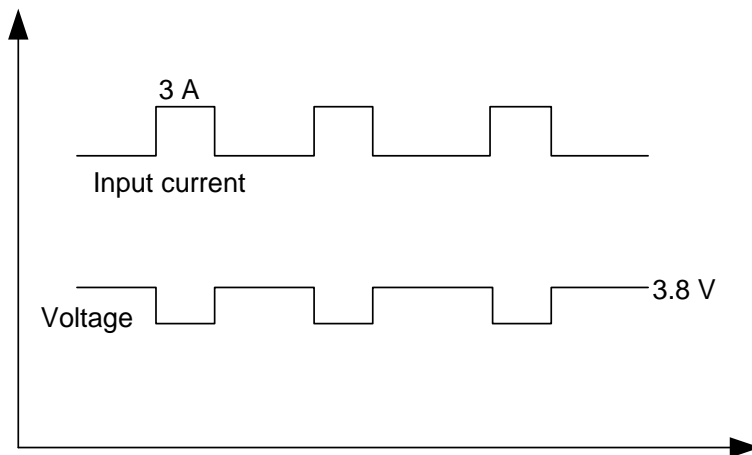

Figure 3: Voltage Drop Sample

To decrease voltage drop, use a bypass capacitor of about 100 μF with low ESR ($\text{ESR} \leq 0.7 \Omega$), and reserve a multi-layer ceramic chip capacitor (MLCC) array due to its ultra-low ESR. It is recommended to use three ceramic capacitors (100 nF, 33 pF, 10 pF) to compose the MLCC array and place these capacitors close to VBAT pins. Additionally, add a 4.7 μF capacitor in parallel. The main power supply from an external application has to be a single voltage source and can be expanded to two sub paths with star structure. The width of VBAT trace should be no less than 3 mm. In principle, the longer the VBAT trace is, the wider it should be.

In addition, to guarantee the stability of the power source, please use a TVS and place it as close to the VBAT pins as possible to enhance surge protection. The following figure shows the star configuration of the power supply.

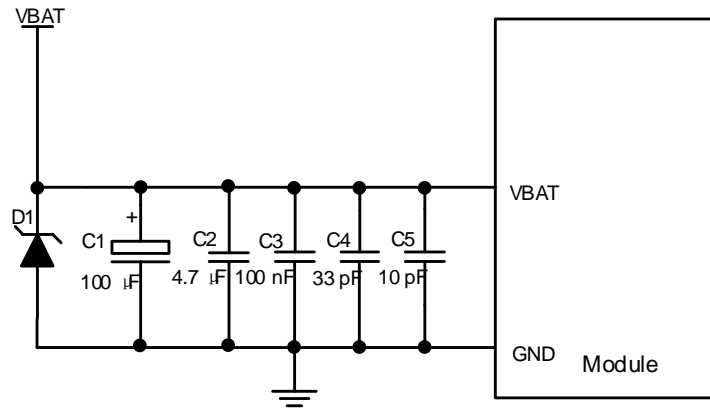

Figure 4: Reference Circuit for the Power Supply

3.4.3. Reference Design for Power Supply

The power design for the module is very important, as the performance of the module largely depends on the power source. The power supply of the module should be able to provide sufficient current of 3 A at least. If the voltage difference between the input and output is not too big, use an LDO when supplying power to the module. If there is a big voltage difference between the input source and the desired output (VBAT), a buck converter is recommended.

The following figure shows a reference design for +5 V input power source. The typical output voltage is 3.8 V and the maximum load current is 5.0 A.

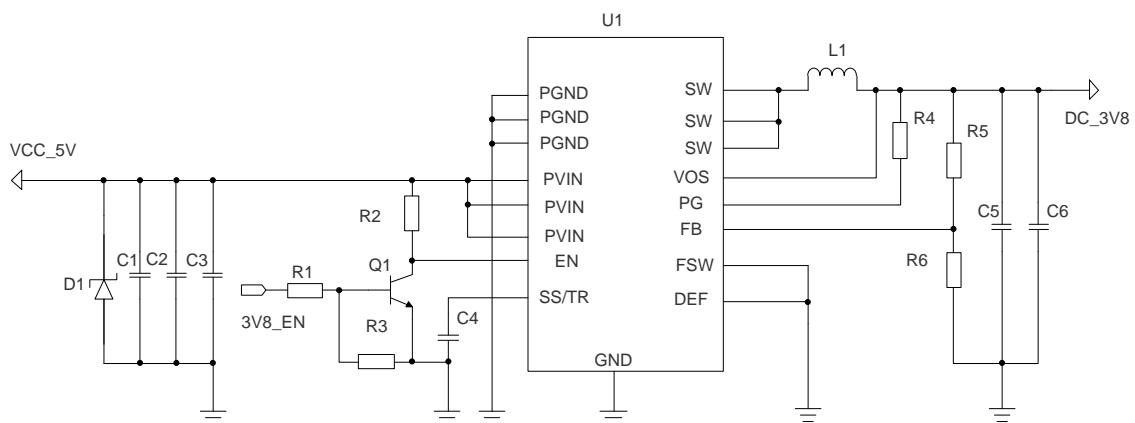

Figure 5: Reference Circuit of Power Supply

NOTE

1. In an abnormal state, it is recommended to restart the module by switching off and then switching back on the power supply.

- The module supports battery charging by default. If the above power supply design is adopted, disable the charging function by software, or connect VBAT to a Schottky diode in series to avoid the reverse current to the power supply IC.

3.5. Turn On/Off

3.5.1. Turn On with PWRKEY

The module can be turned on by driving the PWRKEY pin low for at least 1.6 s. The PWRKEY pin is pulled up to 1.1 V internally. It is recommended to use an open collector driver to control PWRKEY. A simple reference circuit is illustrated in the following figure.

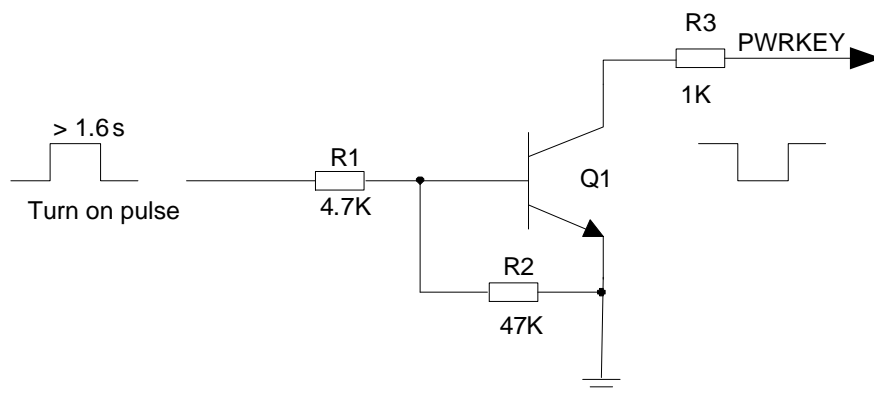

Figure 6: Turn On the Module with Open Collector Driver

Another way to control PWRKEY is by using a button directly. You must place a TVS component nearby the button for ESD protection. A reference circuit is shown by the following figure.

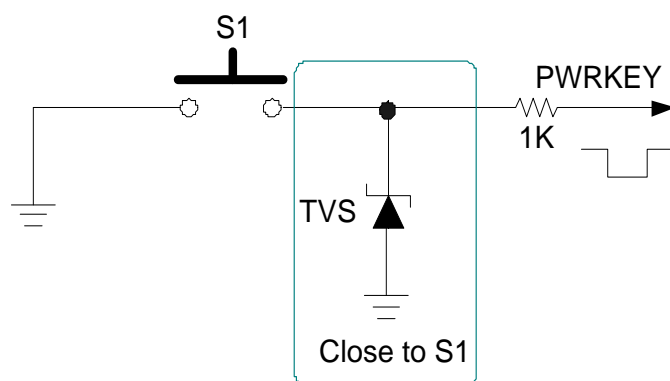

Figure 7: Turn On the Module Using Button

The turning-on scenario is illustrated in the following figure.

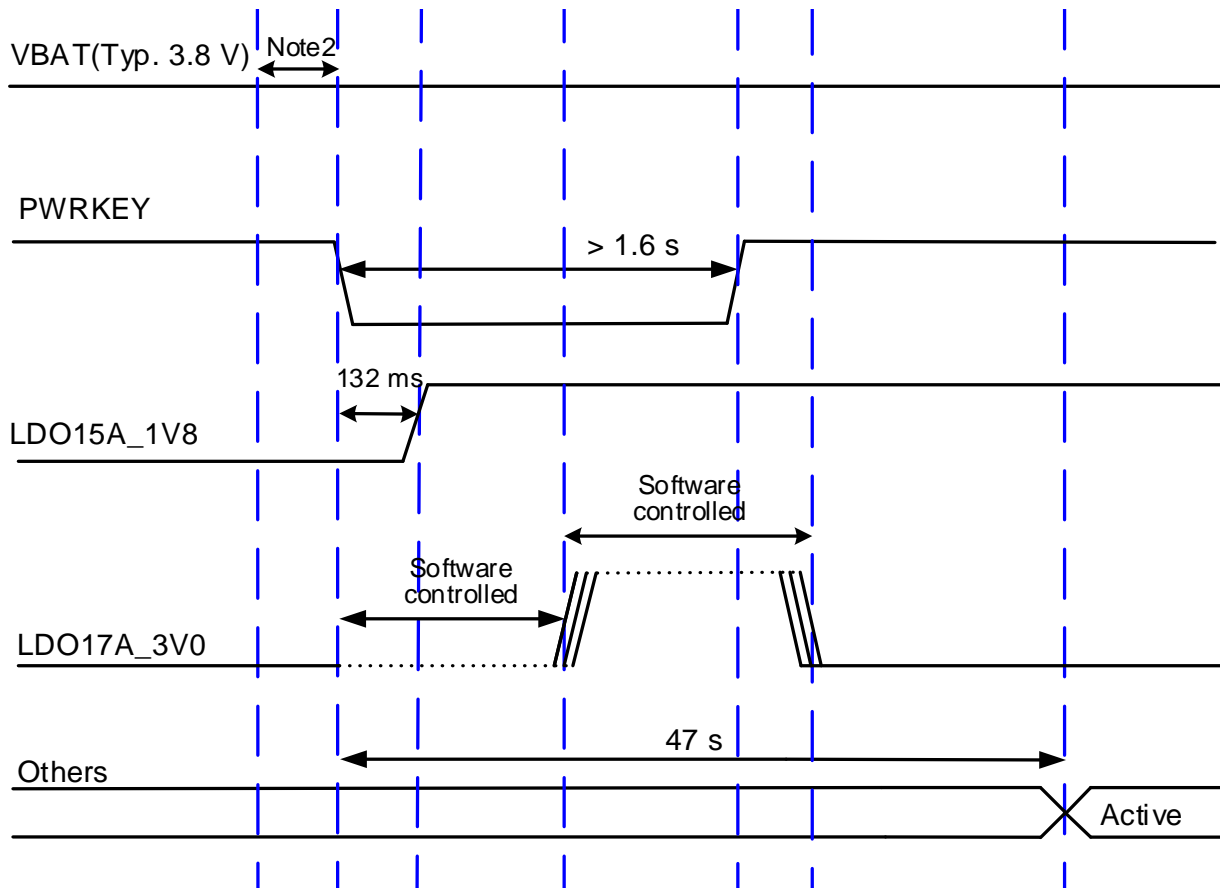

Figure 8: Turn-on Timing

NOTE

1. When the module is turned on for the first time, the turn-on timing may be different from that shown above.
2. Make sure that VBAT is stable before pulling down PWRKEY. It is recommended to wait until VBAT is stable at 3.8 V for at least 30 ms before pulling down PWRKEY. Additionally, do not keep pulling PWRKEY down all the time.

3.5.2. Turn Off

Drive the PWRKEY pin low for at least 1 s, and then choose to turn off the module when the prompt window comes up.

You can also force the module to turn off by driving PWRKEY low for at least 8 s. The force-turn-off timing is illustrated by the following figure.

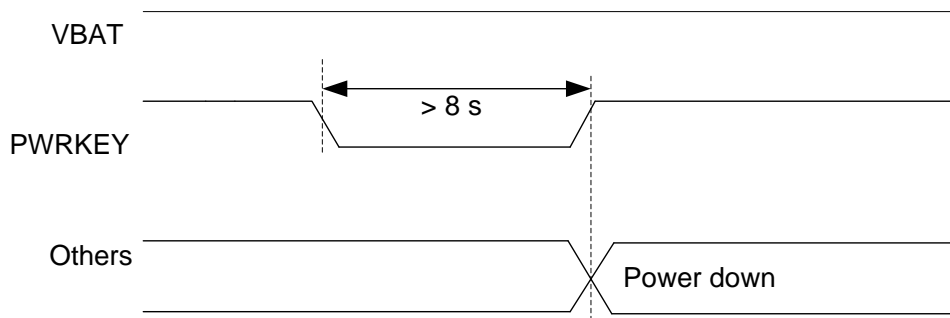

Figure 9: Forced Turn-off Timing

3.6. VRTC

The RTC (Real Time Clock) can be powered by an external power source through VRTC when the module is powered down and there is no power supplied to VBAT. The external power source can be a rechargeable battery (such as a coin cell) according to application demands. A reference circuit design is shown below.

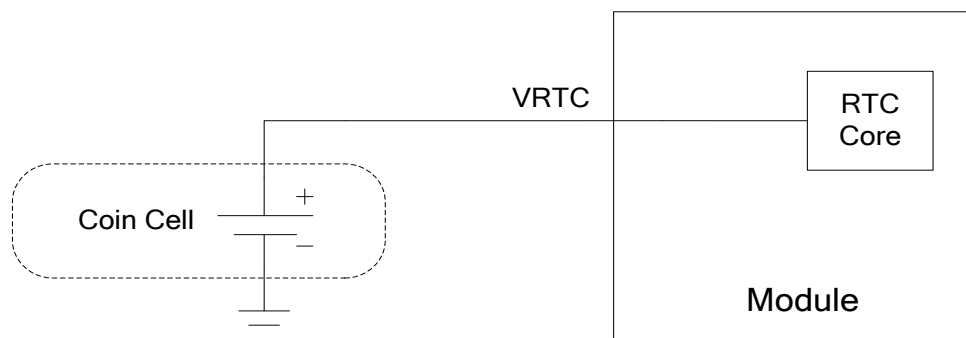

Figure 10: RTC Powered by Coin Cell

If RTC is ineffective, it can be synchronized through the network after the module is turned on. The recommended input voltage range for VRTC is 2.5–3.2 V and the recommended typical value is 3.0 V.

3.7. Power Output

The module supports output of regulated voltages for peripheral circuits. In applications, it is recommended to use a 33 pF and a 10 pF capacitor in parallel in the circuit to suppress high-frequency noise.

Table 8: Power Description

Pin Name	Pin No.	Default Voltage (V)	Driving Current (mA)	@ Idle State
LDO15A_1V8	111	1.8	200	Keeps ON
LDO_IOVDD	125	1.8	300	-
VDD_2V8	129	2.8	500	-
LDO17A_3V0	156	3.0	192	-
SD_LDO21	38	2.95	841	-
SD_LDO4	32	1.8/2.95	22	-
USIM1_VDD	26	1.8/2.95	67	-
USIM2_VDD	21	1.8/2.95	67	-

3.8. Charging Interface

The module supports battery charging. The battery charger IC in the module supports trickle charging, constant current charging and constant voltage charging modes, which optimize the charging procedure for Li-ion batteries.

- Trickle charging: There are two steps in this mode. When the battery voltage is below 2.1 V, a 90 mA trickle charging current is applied to the battery. When the battery voltage is charged up and is between 2.1 V and 3.4 V, the charging current can be set to 400 mA maximally.
- Constant current mode (CC mode): When the battery is increased to 3.4 to 4.2 V, the system will switch to CC mode. The maximum charging current is 1.85 A when an adapter is used for battery charging, and the maximum charging current is 450 mA for USB charging.
- Constant voltage mode (CV mode): When the battery voltage reaches the final value 4.35 V, the system will switch to CV mode and the charging current will decrease gradually. When the battery level reaches 100 %, charging is completed.

Table 9: Pin Definition of Charging Interface

Pin Name	Pin No.	I/O	Description	Comment
BAT_P	133	AI	Battery voltage detect (+)	Cannot be kept open.
BAT_M	183	AI	Battery voltage detect (-)	
BAT_THERM	134	AI	Battery temperature detect	Internal pull up by default. Supports 47 kΩ NTC thermistor by default. If unused, connect it to GND with a 47 kΩ resistor.
BAT_ID	185	AI	Battery type detect	Internally pulled down with a 100 kΩ resistor. If unused, keep it open.

The module supports battery temperature detection in the condition that the battery integrates a thermistor (47 kΩ 1 % NTC thermistor with a B-constant of 4050 K by default) and the thermistor is connected to BAT_THERM pin. If the BAT_THERM pin is not connected, there will be malfunctions such as battery charging failure, battery level display error, etc. The battery charge temperature range varies with different types of batteries.

A reference design for the battery charging circuit is shown below.

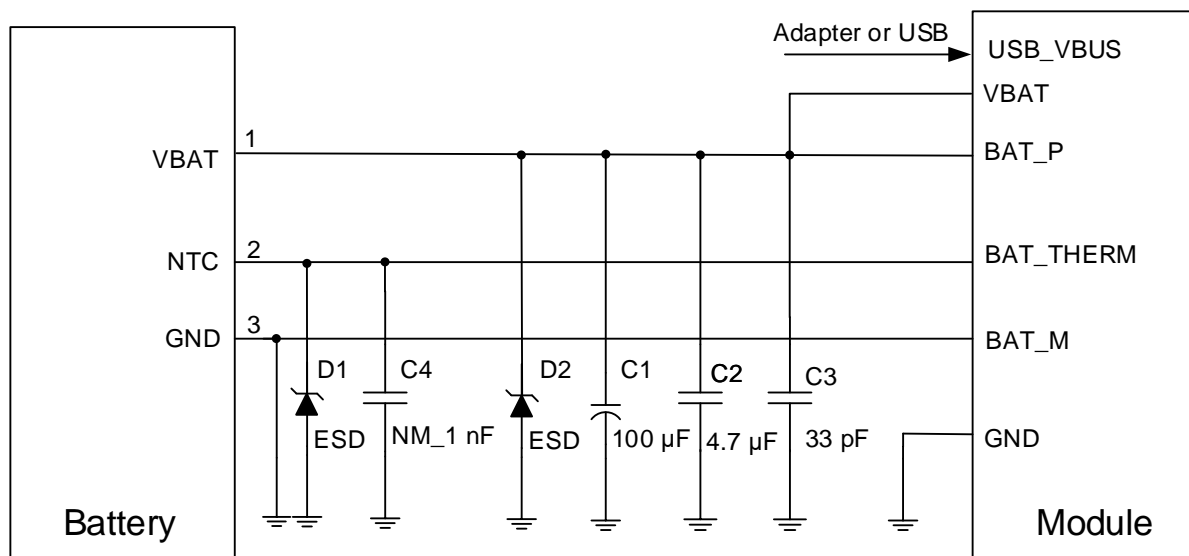

Figure 11: Reference Design for Battery Charging Circuit

Mobile devices such as mobile phones or handheld POS systems are powered by batteries. For different batteries, you should modify the charging and discharging curve correspondingly to achieve the best performance.

If the thermistor is not available in the battery, or an adapter is utilized to power the module, you must connect BAT_THERM to GND via a 47 kΩ resistor. Otherwise, the system may mistakenly judge that the battery temperature is abnormal, and therefore cause battery charging failure.

BAT_P and BAT_M must be connected. Otherwise, exceptions in voltage detection will be caused, with associated problems of turn-on/off and battery charging/discharging.

3.9. USB Interface (Type-C)

The module provides one USB interface which complies with both USB 3.1 and USB 2.0 specifications and supports superspeed (5 Gbps) and high-speed (480 Mbps), and full-speed (12 Mbps) modes. The USB interface supports USB OTG and is used for AT command transmission, data transmission, software debugging and firmware upgrade.

The module only supports USB Type-C. The USB interface has one USB 2.0 compliant high-speed differential channel (USB_DP, USB_DM) and one USB 3.1 compliant superspeed differential channel (USB_SS1_RX_P/M, USB_SS1_TX_P/M and USB_SS2_RX_P/M, USB_SS2_TX_P/M).

When Type-C is plugged in with one side up, the external device is detected by USB_CC1, and the data will be transmitted through USB_SS1; when it is plugged in with the other side up, the external device is detected by USB_CC2, and the data will be transmitted through USB_SS2. The following table shows the pin definition of USB interface.

Table 10: Pin Definition of USB Interface

Pin Name	Pin No.	I/O	Description	Comment
USB_VBUS	141, 142	PIO	Charging power input. Power supply output for OTG device. USB/adaptor insertion detection	Maximum output current is 500 mA.
USB_DM	13	AIO	USB differential data (-)	90 Ω differential impedance.
USB_DP	14	AIO	USB differential data (+)	USB 2.0 standard compliant.
USB_SS1_RX_P	252	AI	USB 3.1 channel 1 superspeed receive (+)	90 Ω differential impedance.
USB_SS1_RX_M	270	AI	USB 3.1 channel 1 superspeed receive (-)	
USB_SS1_TX_P	254	AO	USB 3.1 channel 1 superspeed transmit (+)	USB 3.1 standard compliant.
USB_SS1_TX_M	253	AO	USB 3.1 channel 1 superspeed transmit (-)	

USB_SS2_RX_P	152	AI	USB 3.1 channel 2 superspeed receive (+)	
USB_SS2_RX_M	192	AI	USB 3.1 channel 2 superspeed receive (-)	
USB_SS2_TX_P	150	AO	USB 3.1 channel 2 superspeed transmit (+)	
USB_SS2_TX_M	151	AO	USB 3.1 channel 2 superspeed transmit (-)	
USB_CC1	249	AI	USB Type-C detect 1	-
USB_CC2	246	AI	USB Type-C detect 2	-

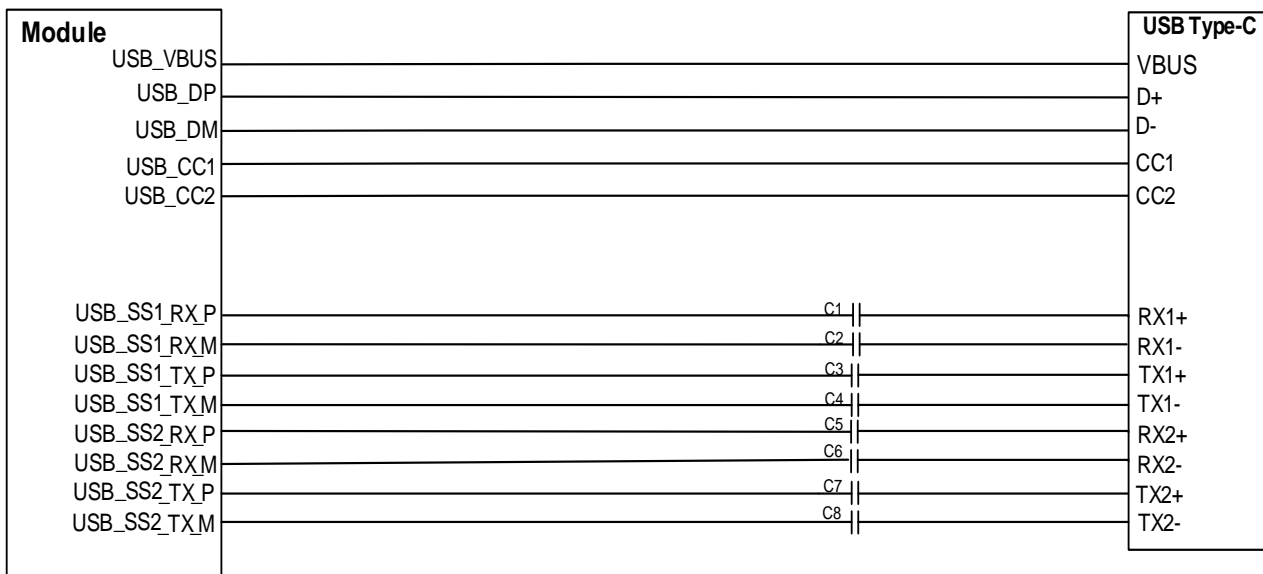

Figure 12: USB Interface Reference Design (OTG Supported)

In order to ensure USB performance, comply with the following principles when designing the USB interface.

- Route the USB signal traces as a differential pair with total grounding. The impedance of USB differential trace should be controlled to 90 Ω.
- Keep the ESD protection component as close as possible to the USB connector. Pay attention to the influence of junction capacitance of ESD protection component on USB data lines. Typically, the capacitance value should be less than 2 pF for USB 2.0 and less than 0.5 pF for USB 3.1.
- Do not route signal traces under crystals, oscillators, magnetic devices or RF signal traces. Route the USB differential traces in inner-layer with ground shielding on not only the upper and lower layers but also the right and left sides.
- Make sure the intra-pair length difference within USB 2.0 differential pair does not exceed 2 mm, and that within USB 3.1 Rx or Tx differential pair does not exceed 0.7 mm.
- The spacing between USB signals and all other signals should be at least 4 times the trace width while the signals between Rx and Tx should be at least 3 times the trace width.

- For USB 3.1, it is suggested to do simulation after the design is completed. If the cable is too long or there are too many vias, a redriver needs to be added to ensure the quality of signal transmission if necessary.

Table 11: USB Trace Length Inside the Module

Pin No.	Signal	Length (mm)	Length Difference (DP - DM)
13	USB_DM	24.13	0.24
14	USB_DP	24.37	
252	USB_SS1_RX_P	16.33	-0.17
270	USB_SS1_RX_M	16.50	
254	USB_SS1_TX_P	10.07	-0.07
253	USB_SS1_TX_M	10.14	
152	USB_SS2_RX_P	17.74	-0.28
192	USB_SS2_RX_M	18.02	
150	USB_SS2_TX_P	20.84	0.3
151	USB_SS2_TX_M	20.54	

3.10. UART Interfaces

The module provides three UART interfaces:

- UART0: four-wire UART interface, supports RTS and CTS hardware flow control
- UART4 (debug UART): two-wire UART interface, used for debugging by default
- UART1: two-wire UART interface

Table 12: Pin Definition of UART Interfaces

Pin Name	Pin No.	I/O	Description	Comment
UART0_TXD	34	DO	UART0 transmit	1.8 V power domain. If unused, keep it open.
UART0_RXD	35	DI	UART0 receive	

UART0_RTS	37	DO	DCE request to send signal to DTE
UART0_CTS	36	DI	DCE clear to send signal from DTE
DBG_TXD	94	DO	Debug UART transmit
DBG_RXD	93	DI	Debug UART receive
UART1_TXD	154	DO	UART1 transmit
UART1_RXD	153	DI	UART1 receive

UART0 is a four-wire UART interface with 1.8 V power domain. You should use a level translator if your application is equipped with a 3.3 V UART interface. The following figure shows a reference design.

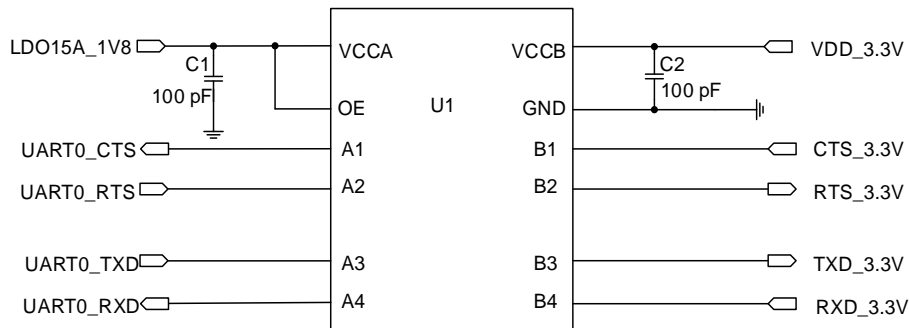

Figure 13: Reference Circuit with Level Translator Chip for UART0

The following figure presents an example of connection between the module and a PC. It is recommended to add a level translator and an RS-232 level translator chip between the module and the PC.

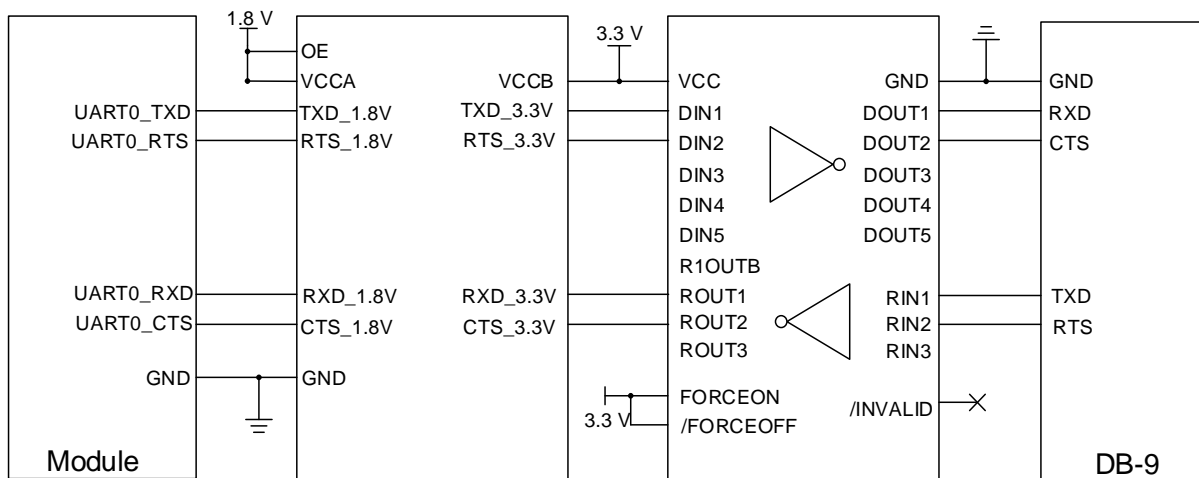

Figure 14: RS-232 Level Match Circuit for UART0

NOTE

UART4 (debug UART) and UART1 are similar to UART0. Please refer to the reference design of UART0 for the designs of the two UARTs.

3.11. (U)SIM Interfaces

The module provides two (U)SIM interfaces that meet ETSI and IMT-2000 requirements. Dual SIM Dual Standby is supported by default. Either 1.8 V or 2.95 V (U)SIM card is supported, and the (U)SIM card is powered by the internal power supply of the module.

Table 13: Pin Definition of (U)SIM Interfaces

Pin Name	Pin No.	I/O	Description	Comment
USIM1_VDD	26	PO	(U)SIM1 card power supply	Either 1.8 V or 2.95 V (U)SIM card is supported.
USIM1_DATA	25	DIO	(U)SIM1 card data	
USIM1_CLK	24	DO	(U)SIM1 card clock	Cannot be multiplexed into a generic GPIO.
USIM1_RST	23	DO	(U)SIM1 card reset	
USIM1_DET	22	DI	(U)SIM1 card hot-plug detect	Active low. Externally pull it up to 1.8 V. If unused, keep it open.
USIM2_VDD	21	PO	(U)SIM2 card power supply	Either 1.8 V or 2.95 V (U)SIM card is supported.
USIM2_DATA	20	DIO	(U)SIM2 card data	
USIM2_CLK	19	DO	(U)SIM2 card clock	Cannot be multiplexed into a generic GPIO.
USIM2_RST	18	DO	(U)SIM2 card reset	
USIM2_DET	17	DI	(U)SIM2 card hot-plug detect	Active low. Externally pull it up to 1.8 V. If unused, keep it open.

The module supports (U)SIM card hot-plug via the USIM_DET pins. This function is disabled by default via software. To enable it, contact Quectel Technical Support to change the software configuration. A reference circuit for (U)SIM interface with an 8-pin (U)SIM card connector is shown below.

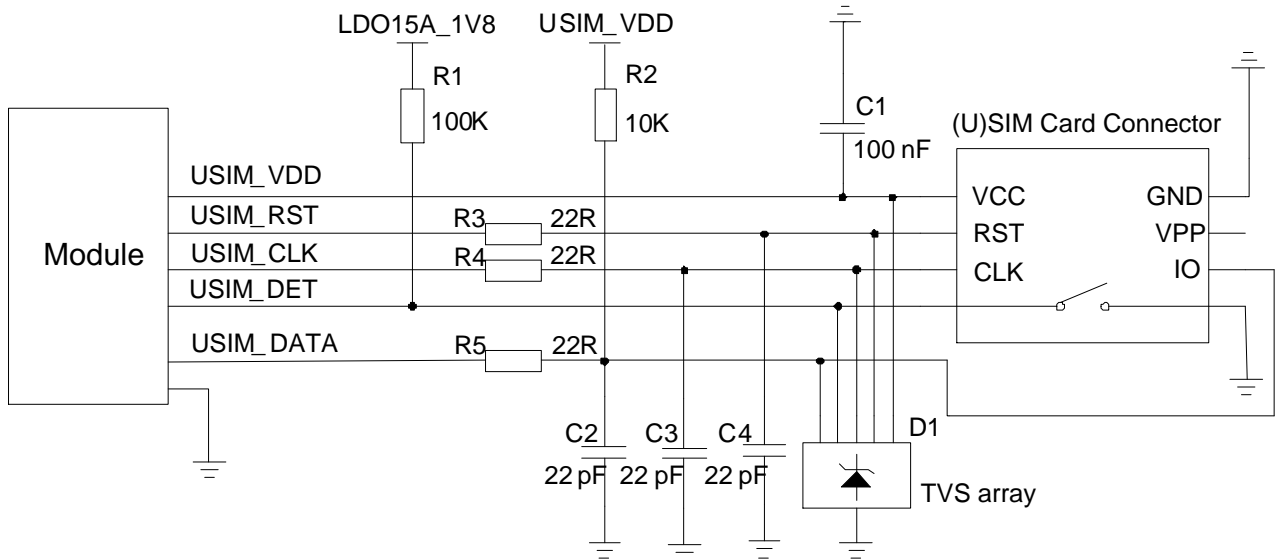

Figure 15: Reference Circuit for (U)SIM Interface with an 8-pin (U)SIM Card Connector

If you do not need hot-plug detection, keep USIM1_DET and USIM2_DET pins open. The following is a reference circuit for (U)SIM interface with a 6-pin (U)SIM card connector when hot-plug detection is not needed.

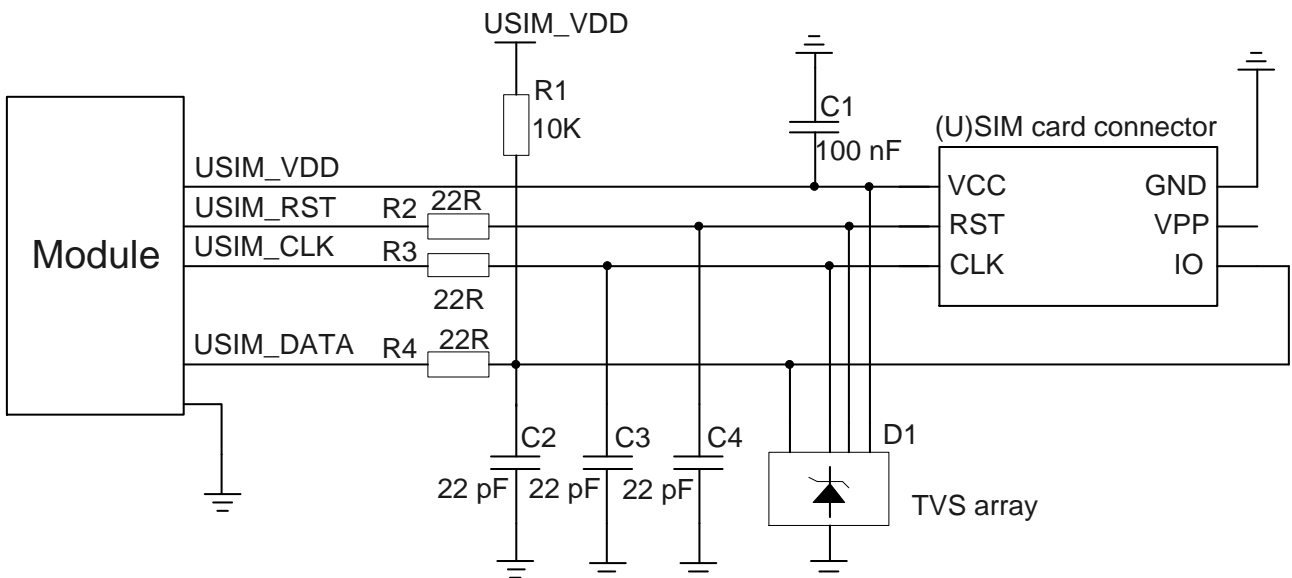

Figure 16: Reference Circuit for (U)SIM Interface with a 6-pin (U)SIM Card Connector

To enhance the reliability and availability of the (U)SIM card in applications, please follow the criteria below in (U)SIM circuit design:

- Place the (U)SIM card connector as close to the module as possible. Keep the trace length as short as possible, at most 200 mm.
- Keep (U)SIM card signals away from RF and VBAT traces.
- Reserve a filter capacitor for USIM_VDD, and its maximum capacitance should not exceed 1 μ F. Additionally, place the capacitor near the (U)SIM card connector.
- To avoid cross-talk between USIM_DATA and USIM_CLK, keep them away from each other and shield them with ground. USIM_RST also needs ground protection.
- To ensure better ESD protection, it is recommended to add a TVS array with a parasitic capacitance not exceeding 10 pF. Add 22 Ω resistors in series between the module and (U)SIM card to suppress EMI such as spurious transmission. Please note that the (U)SIM peripheral circuit should be close to the (U)SIM card connector.
- Add 22 pF capacitors in parallel on USIM_DATA, USIM_CLK and USIM_RST signal lines to filter RF interference, and place them as close to the (U)SIM card connector as possible.

3.12. SD Card Interface

SD Card interface of the module supports SD 3.0 protocol. The pin definition of SD card interface is shown below.

Table 14: Pin Definition of SD Card Interface

Pin Name	Pin No.	I/O	Description	Comment
SD_CLK	39	DO	SD card clock	
SD_CMD	40	DO	SD card command	
SD_DATA0	41	DIO	SDIO data bit 0	50 Ω characteristic impedance.
SD_DATA1	42	DIO	SDIO data bit 1	
SD_DATA2	43	DIO	SDIO data bit 2	
SD_DATA3	44	DIO	SDIO data bit 3	
SD_DET	45	DI	SD card hot-plug detect	Active low.
SD_LDO21	38	PO	SD card power supply	-
SD_LDO4	32	PO	1.8/2.95 V output power for SD card pull-up circuits	-

A reference circuit for the SD card interface is shown below.

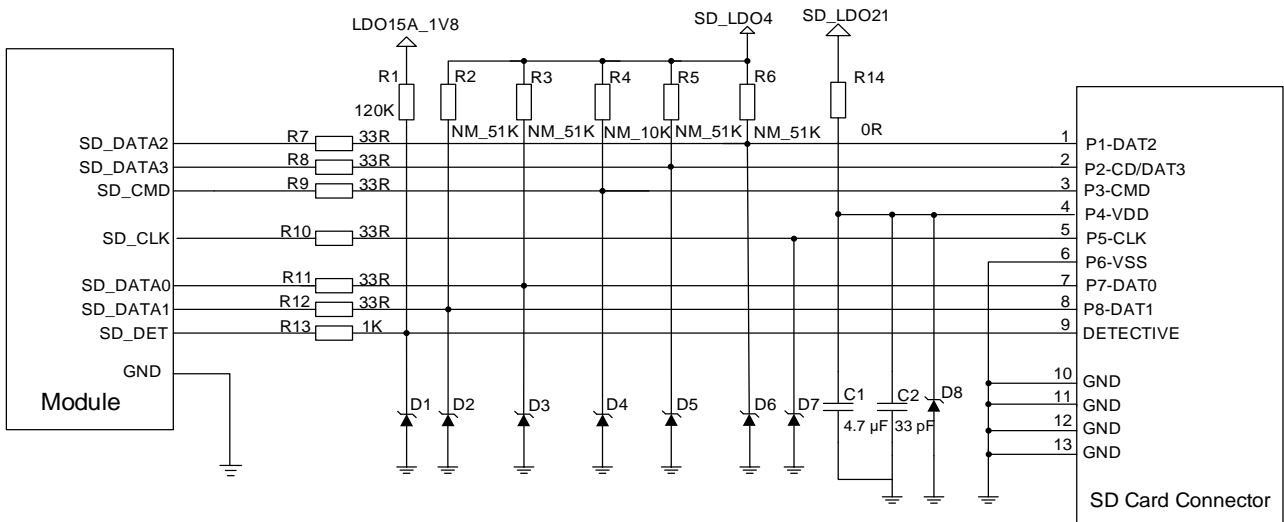

Figure 17: Reference Circuit for the SD Card Interface

SD_LDO21 is the power supply for the SD card and can provide up to 841 mA output current. Due to the high output current, it is recommended that the trace width should be at least 0.8 mm. To ensure output current stability, add a 4.7 μF and a 33 pF capacitor in parallel near the SD card connector.

SD_CMD, SD_CLK, SD_DATA0, SD_DATA1, SD_DATA2, and SD_DATA3 are all high-speed signal lines. In PCB design, control the characteristic impedance of them to 50 Ω, and do not cross them with other traces. It is recommended to route the traces on the inner layer of the PCB and keep them of the same length. Additionally, SD_CLK needs ground shielding separately.

Trace length requirements:

- Control the impedance to 50 Ω ±10 % and add ground shielding.
- Keep the trace length difference among SD_CLK, SD_CMD and SD_DATA less than 2 mm.

Table 15: SD Card Trace Length Inside the Module

Pin No.	Signal	Length (mm)
39	SD_CLK	35.01
40	SD_CMD	35.12
41	SD_DATA0	34.98
42	SD_DATA1	35.04
43	SD_DATA2	34.98

44 SD_DATA3 35.10

3.13. GPIO Interfaces

The module has abundant GPIO interfaces with a power domain of 1.8 V. The pin definition is listed below.

Table 16: Pin Definition of GPIO Interfaces

Pin Name	Pin No.	I/O	Description	Comment
GPIO_28	33	DIO	General-purpose input/output	
GPIO_31	97	DIO	General-purpose input/output	
GPIO_32	99	DIO	General-purpose input/output	
GPIO_33	108	DIO	General-purpose input/output	
GPIO_34	109	DIO	General-purpose input/output	
GPIO_35	107	DIO	General-purpose input/output	
GPIO_36	110	DIO	General-purpose input/output	
GPIO_55	100	DIO	General-purpose input/output	
GPIO_56	106	DIO	General-purpose input/output	
GPIO_57	112	DIO	General-purpose input/output	Cannot be pulled up when the module is turning on.
GPIO_58	113	DIO	General-purpose input/output	
GPIO_60	123	DIO	General-purpose input/output	
GPIO_86	182	DIO	General-purpose input/output	
GPIO_112	177	DIO	General-purpose input/output	
GPIO_111	267	DIO	General-purpose input/output	
GPIO_98	265	DIO	General-purpose input/output	
GPIO_99	105	DIO	General-purpose input/output	
GPIO_100	264	DIO	General-purpose input/output	
GPIO_101	239	DIO	General-purpose input/output	

GPIO_102	104	DIO	General-purpose input/output
GPIO_103	103	DIO	General-purpose input/output
GPIO_104	101	DIO	General-purpose input/output
GPIO_105	102	DIO	General-purpose input/output
GPIO_106	90	DIO	General-purpose input/output
GPIO_107	98	DIO	General-purpose input/output
GPIO_14	118	DIO	General-purpose input/output
GPIO_15	119	DIO	General-purpose input/output
GPIO_16	116	DIO	General-purpose input/output
GPIO_17	117	DIO	General-purpose input/output
PMU_GPIO03	124	DIO	General-purpose input/output
PMU_GPIO04	115	DIO	General-purpose input/output
PMU_GPIO08	127	DIO	General-purpose input/output
PMU_GPIO07	201	DIO	General-purpose input/output

NOTE

For more details about GPIO configuration, see *document [2]*.

3.14. I2C Interfaces

The module provides four I2C interfaces. All I2C interfaces are open drain signals and therefore you must pull them up externally. The reference power domain is 1.8 V. The sensor I2C interface only supports sensors of ADSP architecture. CAM0 I2C and CAM1 I2C signals are controlled by the Kernel code and support connection to radio-output-related devices.

Table 17: Pin Definition of I2C Interfaces

Pin Name	Pin No.	I/O	Description	Comment
TP_I2C_SCL	47	OD	TP I2C clock	Need to be pulled up to

TP_I2C_SDA	48	OD	TP I2C data	1.8 V externally. Can be used for other I2C devices.
CAM0_I2C_SCL	83	OD	I2C clock of camera 0	Can only be used for camera I2C devices.
CAM0_I2C_SDA	84	OD	I2C data of camera 0	
CAM1_I2C_SCL	166	OD	I2C clock of camera 1	
CAM1_I2C_SDA	205	OD	I2C data of camera 1	Can only be used to for sensors.
SENSOR_I2C_SCL	91	OD	I2C clock for external sensor	
SENSOR_I2C_SDA	92	OD	I2C data for external sensor	

3.15. ADC Interface

The module supports one Analog-to-Digital Converter (ADC) interface. The ADC interface supports resolution of up to 15 bits. The pin definition is shown below.

Table 18: Pin Definition of ADC Interface

Pin Name	Pin No.	I/O	Description	Comment
ADC	128	AI	General-purpose ADC interface	The maximum input voltage is 1.875 V.

3.16. Motor Drive Interface

The pin definition of the motor drive interface is listed below.

Table 19: Pin Definition of Motor Drive Interface

Pin Name	Pin No.	I/O	Description	Comment
VIB_DRV_P	28	PO	Vibration motor driver output control	Connect it to the positive pole of the motor.

The motor is driven by an exclusive circuit, and a reference circuit is shown below.

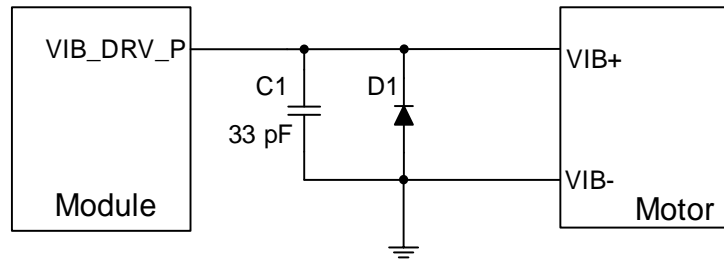

Figure 18: Reference Circuit for Motor Connection

When the motor stops working and the VIB_DRV_P is disconnected, the redundant electricity on the motor can be discharged from the circuit loop formed by diodes, thus avoiding damage to components.

3.17. LCM Interface

The module provides one LCM interface, which is MIPI DSI standard compliant. The interface supports high-speed differential data transmission and supports HD+ display (1680 x 720 @ 60 fps). The pin definition of the LCM interface is shown below.

Table 20: Pin Definition of LCM Interface

Pin Name	Pin No.	I/O	Description	Comment
LCD_RST	49	DO	LCD reset	1.8 V power domain.
LCD_TE	50	DI	LCD tearing effect	
DSI_CLK_N	52	AO	LCD MIPI clock (-)	-
DSI_CLK_P	53	AO	LCD MIPI clock (+)	-
DSI_LN0_N	54	AO	LCD MIPI lane 0 data (-)	-
DSI_LN0_P	55	AO	LCD MIPI lane 0 data (+)	-
DSI_LN1_N	56	AO	LCD MIPI lane 1 data (-)	-
DSI_LN1_P	57	AO	LCD MIPI lane 1 data (+)	-
DSI_LN2_N	58	AO	LCD MIPI lane 2 data (-)	-

DSI_LN2_P	59	AO	LCD MIPI lane 2 data (+)	-
DSI_LN3_N	60	AO	LCD MIPI lane 3 data (-)	-
DSI_LN3_P	61	AO	LCD MIPI lane 3 data (+)	-
PWM	29	DO	PWM output	1.8 V power domain.

A reference circuit for the LCM interface is shown below.

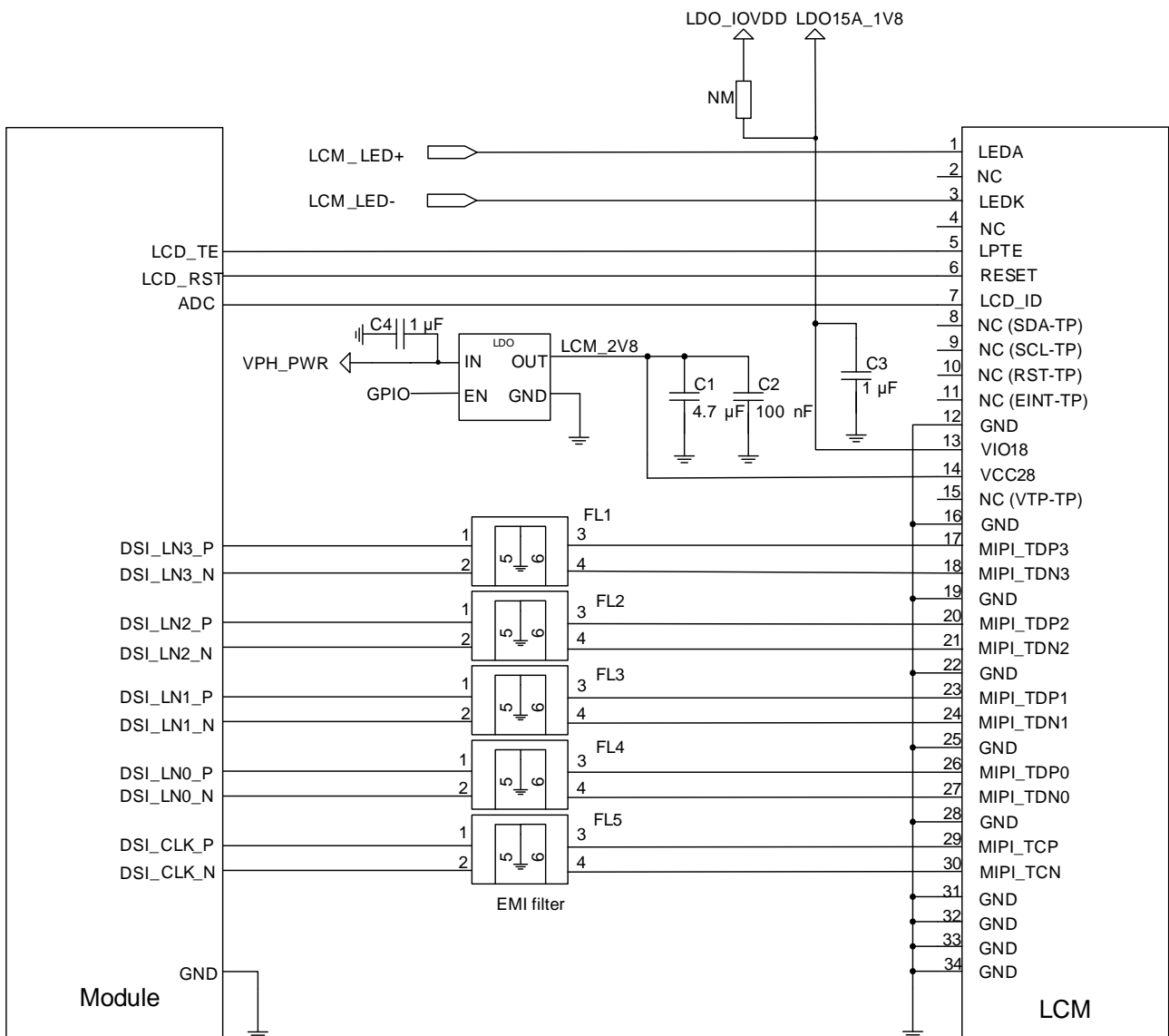

Figure 19: Reference Circuit Design for LCM Interface

MIPI are high-speed signal lines. It is recommended to add common-mode filters in series near the LCM connector, to improve protection against electromagnetic radiation interference.

It is recommended to read the LCM ID register through MIPI when compatible design with other displays is required. If several LCMs share the same IC, it is recommended that the LCM factory should burn an OTP register to distinguish different screens. You can also connect the LCD_ID pin of LCM to the ADC pin of the module, but you need to make sure that the output voltage of LCD_ID should not exceed the voltage range of the ADC pin.

You can design the external backlight driving circuit for LCM according to actual requirements. A reference circuit design is shown in the following figure, in which the PWM pin is used to adjust the backlight brightness.

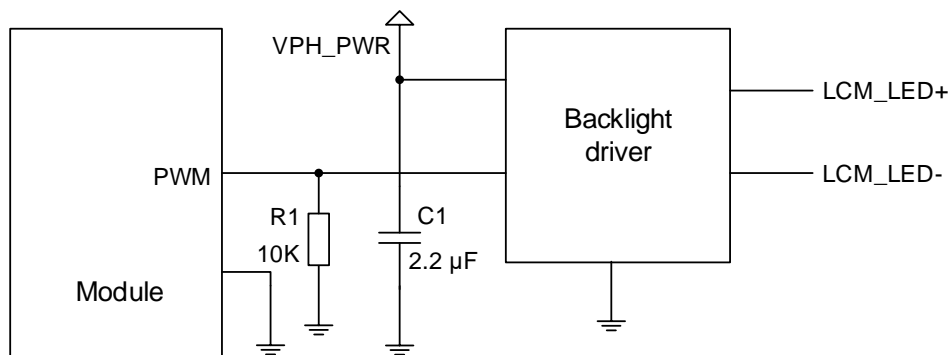

Figure 20: Reference Design for LCM External Backlight Driving Circuit

3.18. Flash Interface

The module supports one flash LED driver, with maximum output current up to 1 A.

Table 21: Pin Definition of Flash Interface

Pin Name	Pin No.	I/O	Description	Comment
FLASH_LED	180	AO	Flash/torch driver output	Supports flash and torch modes.

NOTE

Flash current is programmable in step 12.5 mA (max. 1 A) or 5 mA (max. 640 mA).

3.19. Touch Panel Interface

The module provides one I2C interface for the connection to a Touch Panel (TP), and also provides the corresponding power supply and interrupt pins. The definition of TP interface pin is illustrated below.

Table 22: Pin Definition of Touch Panel Interface

Pin Name	Pin No.	I/O	Description	Comment
TP_RST	31	DO	TP reset	1.8 V voltage domain. Active low.
TP_INT	30	DI	TP interrupt	1.8 V voltage domain.
TP_I2C_SCL	47	OD	TP I2C clock	Need to be pulled up to 1.8 V externally.
TP_I2C_SDA	48	OD	TP I2C data	Can be used for other I2C devices.

A reference circuit for the TP interface is shown below.

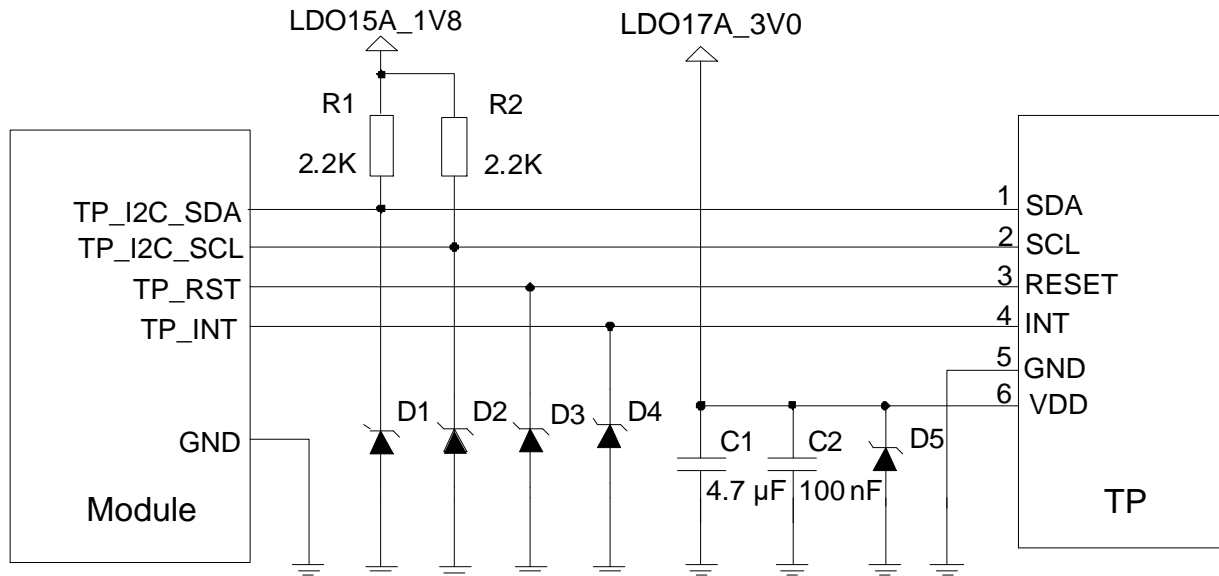

Figure 21: Reference Circuit Design for the Touch Panel Interface

3.20. Camera Interfaces

Based on MIPI CSI standard, the module supports two cameras (4-lane + 4-lane) or three cameras (4-lane + 2-lane + 1-lane), and the maximum pixel of the camera can be up to 25 MP. The video and photo quality are determined by various factors such as the camera sensor and camera lens specifications.

Table 23: Pin Definition of Camera Interfaces

Pin Name	Pin No.	I/O	Description	Comment
CSI1_CLK_N	63	AI	MIPI CSI1 clock (-)	-
CSI1_CLK_P	64	AI	MIPI CSI1 clock (+)	-
CSI1_LN0_N	65	AI	MIPI CSI1 lane 0 data (-)	-
CSI1_LN0_P	66	AI	MIPI CSI1 lane 0 data (+)	-
CSI1_LN1_N	67	AI	MIPI CSI1 lane 1 data (-)	-
CSI1_LN1_P	68	AI	MIPI CSI1 lane 1 data (+)	-
CSI1_LN2_N	72	AI	MIPI CSI1 lane 2 data (-)	-
CSI1_LN2_P	73	AI	MIPI CSI1 lane 2 data (+)	-
CSI1_LN3_N	70	AI	MIPI CSI1 lane 3 data (-)	-
CSI1_LN3_P	71	AI	MIPI CSI1 lane 3 data (+)	-
CSI0_CLK_N	157	AI	MIPI CSI0 clock (-)	-
CSI0_CLK_P	196	AI	MIPI CSI0 clock (+)	-
CSI0_LN0_N	158	AI	MIPI CSI0 lane 0 data (-)	-
CSI0_LN0_P	197	AI	MIPI CSI0 lane 0 data (+)	-
CSI0_LN1_N	159	AI	MIPI CSI0 lane 1 data (-)	-
CSI0_LN1_P	198	AI	MIPI CSI0 lane 1 data (+)	-
CSI0_LN2_N	160	AI	MIPI CSI0 lane 2 data (-)	-
CSI0_LN2_P	199	AI	MIPI CSI0 lane 2 data (+)	-
CSI0_LN3_N	161	AI	MIPI CSI0 lane 3 data (-)	-

CSI0_LN3_P	200	AI	MIPI CSI0 lane 3 data (+)	-
CAM0_I2C_SCL	83	OD	I2C clock of camera 0	Need to be pulled up to 1.8 V externally.
CAM0_I2C_SDA	84	OD	I2C data of camera 0	Can only be used for camera I2C devices.
CAM0_PWDN	80	DO	Power down of camera 0	
CAM1_PWDN	82	DO	Power down of camera 1	
CAM2_PWDN	163	DO	Power down of camera 2	
CAM0_MCLK	74	DO	Master clock of camera 0	
CAM1_MCLK	75	DO	Master clock of camera 1	1.8 V power domain.
CAM2_MCLK	165	DO	Master clock of camera 2	
CAM0_RST	79	DO	Reset of camera 0	
CAM1_RST	81	DO	Reset of camera 1	
CAM2_RST	164	DO	Reset of camera 2	
CAM1_I2C_SCL	166	OD	I2C clock of camera 1	Need to be pulled up to 1.8 V externally.
CAM1_I2C_SDA	205	OD	I2C data of camera 1	Can only be used for camera I2C devices.

The following is a reference circuit design for 3-camera applications.

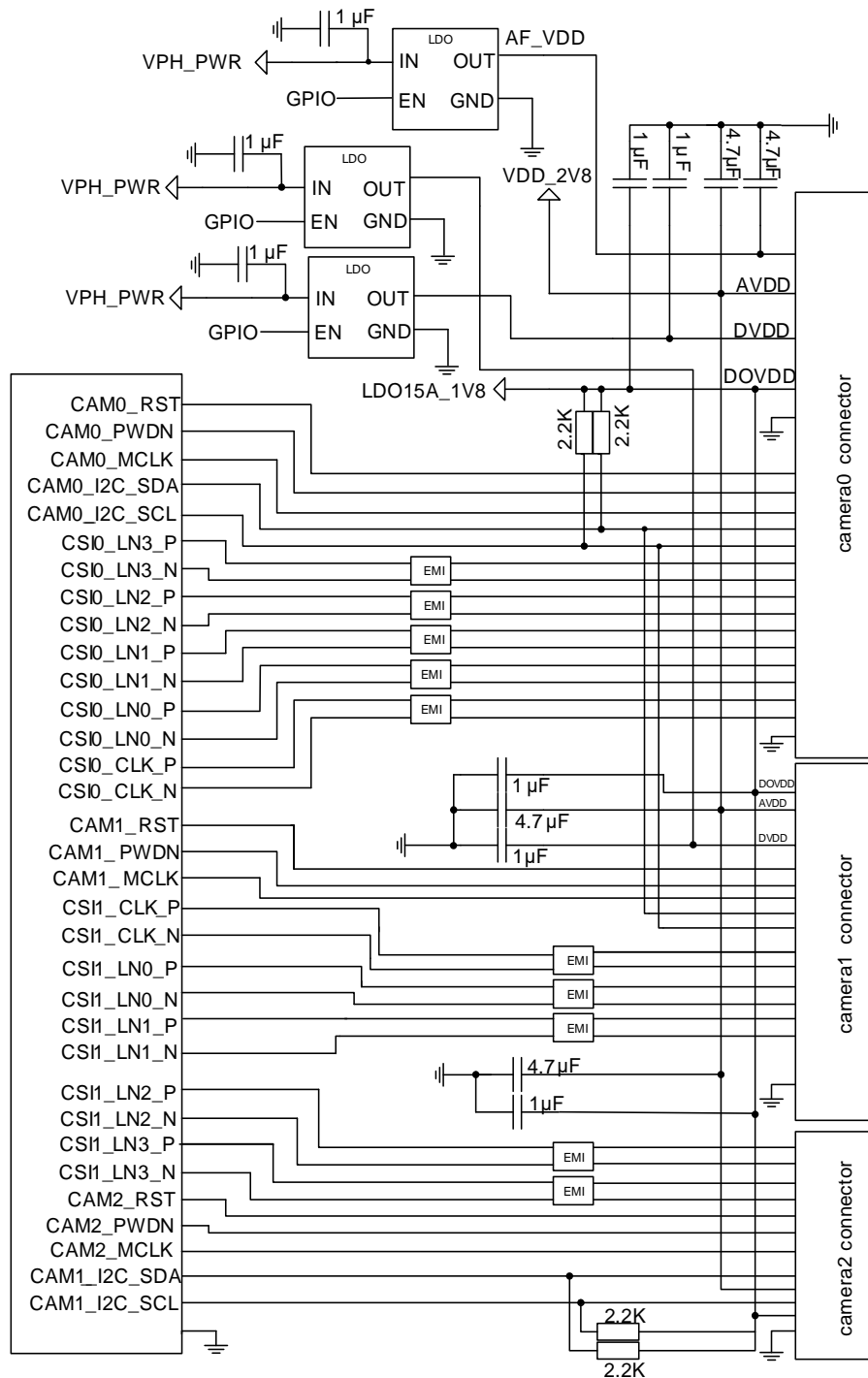

Figure 22: Reference Circuit Design for 3-Camera Applications

NOTE

In 3-camera applications, CSI1_LN3_P and CSI1_LN3_N are used as MIPI clock signals of camera 2. CSI1_LN2_P and CSI1_LN2_N are used as MIPI data signals of camera 2.

3.20.1. MIPI Design Considerations

- Special attention should be paid to the pin definition of LCM and camera connectors. Make sure the module and the connectors are correctly connected.
- MIPI lines are high-speed signal lines for DSI-supported maximum data rate of up to 1.5 Gbps and CSI-supported maximum data rate of up to 2.5 Gbps. The differential impedance should be controlled to 100 Ω. Additionally, it is recommended to route the trace on the inner layer of PCB, and do not cross it with other traces. For the same group of DSI or CSI signals, keep all the MIPI traces of the same length. In order to avoid crosstalk, keep a distance of 1.5 times the trace width among MIPI signal lines. During impedance matching, do not connect GND on different planes to ensure impedance consistency.
- It is recommended to select a low-capacitance TVS for ESD protection and the recommended parasitic capacitance should be below 1 pF.
- Route MIPI traces according to the following rules:
 - a) The total trace length should not exceed 240 mm;
 - b) Control the differential impedance to 100 Ω ± 10 %;
 - c) Control intra-lane length difference within 0.7 mm;
 - d) Control inter-lane length difference within 1.4 mm.

Table 24: MIPI Trace Length Inside the Module

Pin Name	Pin No.	Length (mm)	Length Difference (P - N)
DSI_CLK_N	52	38.53	0.23
DSI_CLK_P	53	38.30	
DSI_LN0_N	54	38.59	0.16
DSI_LN0_P	55	38.43	
DSI_LN1_N	56	38.22	-0.25
DSI_LN1_P	57	38.47	
DSI_LN2_N	58	38.84	0.28
DSI_LN2_P	59	38.56	
DSI_LN3_N	60	38.74	0.26
DSI_LN3_P	61	38.48	
CSI1_CLK_N	63	18.87	-0.03
CSI1_CLK_P	64	18.84	
CSI1_LN0_N	65	19.42	0.24

CSI1_LN0_P	66	19.18	
CSI1_LN1_N	67	19.02	-0.26
CSI1_LN1_P	68	19.28	
CSI1_LN2_N	72	19.53	0.3
CSI1_LN2_P	73	19.23	
CSI1_LN3_N	70	18.93	0.11
CSI1_LN3_P	71	18.82	
CSI0_CLK_N	157	20.94	0.21
CSI0_CLK_P	196	20.73	
CSI0_LN0_N	158	18.74	0.34
CSI0_LN0_P	197	18.40	
CSI0_LN1_N	159	17.18	-0.19
CSI0_LN1_P	198	17.37	
CSI0_LN2_N	160	8.28	0.13
CSI0_LN2_P	199	8.15	
CSI0_LN3_N	161	4.97	0.27
CSI0_LN3_P	200	4.70	

3.21. Sensor Interface

The module supports communication with sensors via I2C interfaces, and it supports ALS/PS, BDS, accelerometer, gyroscope, etc.

Table 25: Pin Definition of Sensor Interface

Pin Name	Pin No.	I/O	Description	Comment
SENSOR_I2C_SCL	91	OD	I2C clock for external sensor	Need to be pulled up to 1.8 V externally.
SENSOR_I2C_SDA	92	OD	I2C data for external sensor	Can only be used to connect sensor devices.

3.22. Audio Interfaces

The module provides three analog input channels and three analog output channels. The following table shows the pin definition.

Table 26: Pin Definition of Audio Interfaces

Pin Name	Pin No.	I/O	Description	Comment
MIC_BIAS1	147	PO	Bias voltage 1 output for microphone	The rated output current is 3 mA.
MIC1_P	4	AI	Microphone input for channel 1 (+)	-
MIC1_M	5	AI	Microphone input for channel 1 (-)	-
MIC2_P	6	AI	Microphone input for headset (+)	-
MIC3_P	148	AI	Microphone input for channel 3 (+)	-
MIC3_M	149	AI	Microphone input for channel 3 (-)	-
MIC_BIAS3	155	PO	Bias voltage 3 output for microphone	The rated output current is 3 mA. The output voltage is fixed to 1.8 V and cannot be adjusted.
EAR_P	8	AO	Earpiece output (+)	-
EAR_M	9	AO	Earpiece output (-)	-
LINEOUT_P	10	AO	Audio line differential output (+)	The typical output voltage is 2 Vrms.
LINEOUT_M	11	AO	Audio line differential output (-)	-
HPH_R	136	AO	Headphone right channel output	-
HPH_GND	137	AO	Headphone reference ground	-
HPH_L	138	AO	Headphone left channel output	-
HS_DET	139	AI	Headset hot-plug detect	High level by default.

- The module offers three audio input channels.
- The output voltage range of MIC_BIAS1 is programmable between 1.6 V and 2.85 V, and the maximum output current is 3 mA. MIC_BIAS3 supports 1.8 V pull-up output only and is not programmable.
- The earpiece interface uses differential output.

- The lineout interface uses differential output, lineout is used as audio PA input.
- The headphone interface features stereo left and right channel output, and supports headphone insertion detection.

3.22.1. Reference Circuit Design for Microphone Interfaces

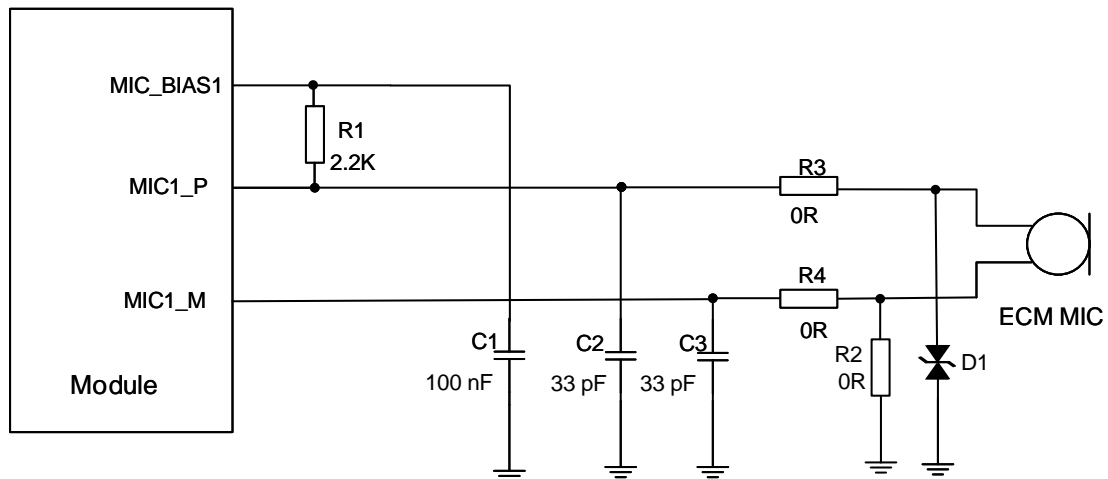

Figure 23: Reference Circuit Design for ECM Microphone Interface

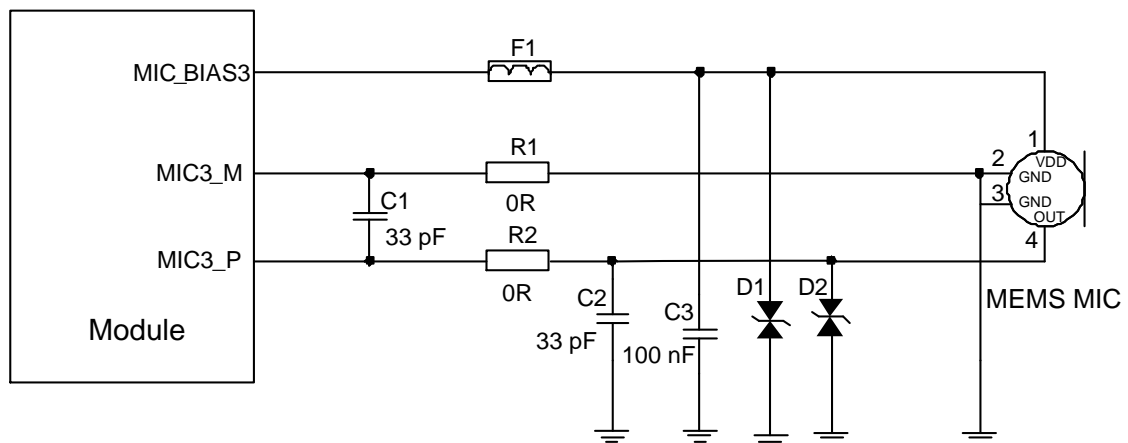

Figure 24: Reference Circuit Design for MEMS Microphone Interface

3.22.2. Reference Circuit Design for Earpiece Interface

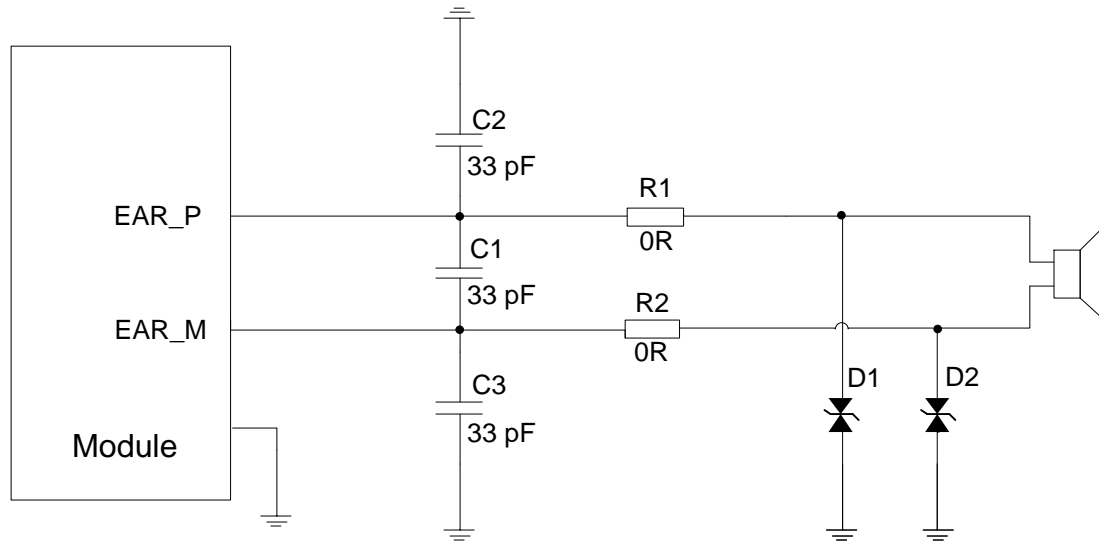

Figure 25: Reference Circuit Design for Earpiece Interface

3.22.3. Reference Circuit Design for Headset Interface

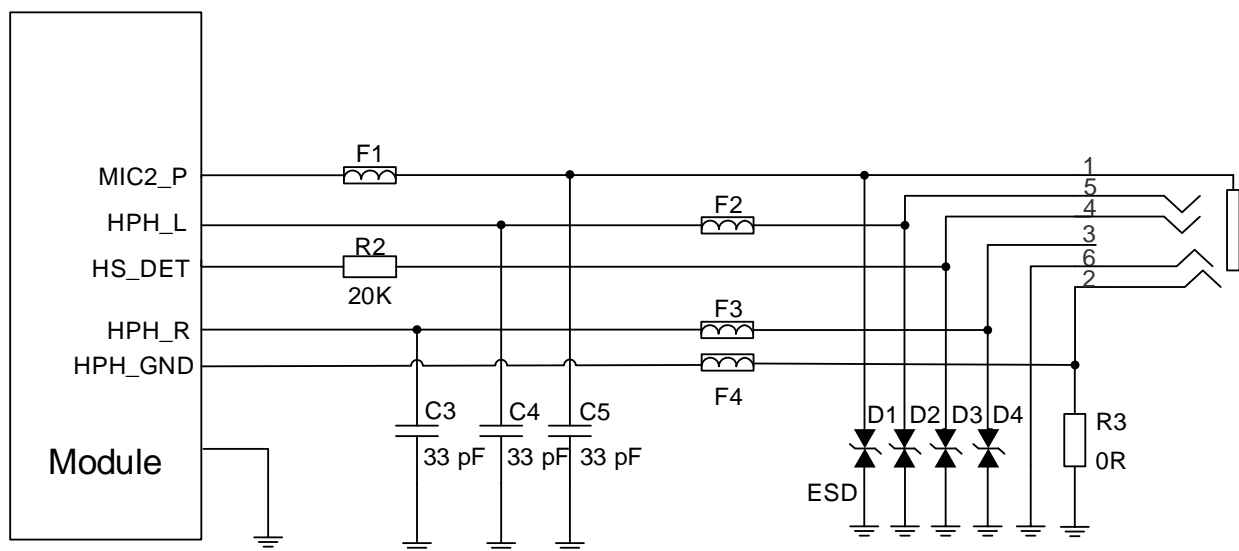

Figure 26: Reference Circuit Design for Headset Interface

3.22.4. Reference Circuit Design for Lineout Interface

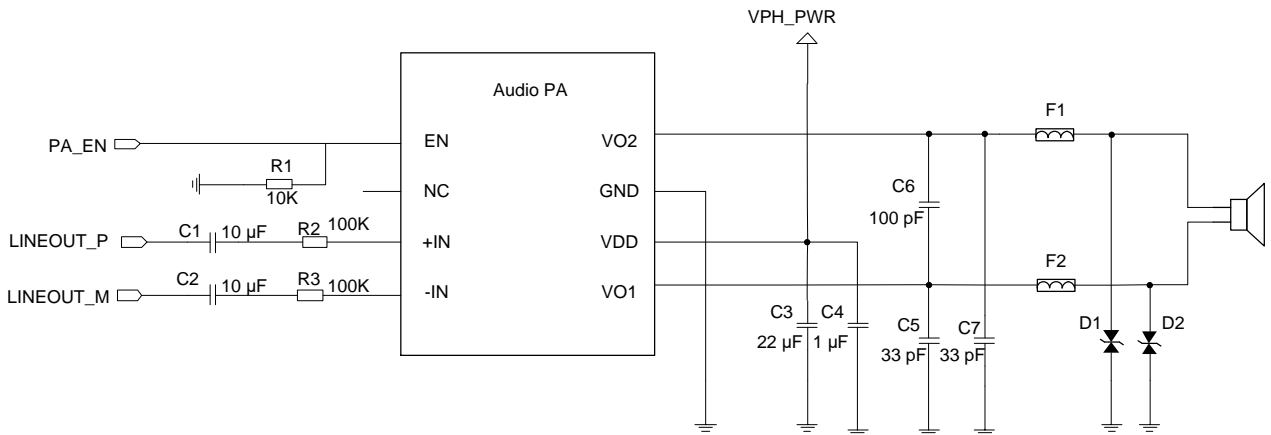

Figure 27: Reference Circuit Design for Lineout Interface

3.22.5. Audio Signal Design Considerations

It is recommended to use the ECM microphone with dual built-in capacitors (e.g., 10 pF and 33 pF) to filter out RF interference, thus reducing TDD noise. The 33 pF capacitor is applied to filter out RF interference when the module is transmitting at EGSM900. The 10 pF capacitor is used to filter out RF interference at DCS1800. Without this capacitor, TDD noise could be heard during voice calls. Please note that the resonant frequency point of a capacitor largely depends on its material and manufacturing technique. Therefore, you should consult the capacitor vendors to choose the most suitable capacitor to filter out the high-frequency noises.

The severity of RF interference in the voice channel during GSM transmitting largely depends on the application design. In some cases, EGSM900 TDD noise is more severe; while in other cases, DCS1800 TDD noise is more obvious. Therefore, you should select a suitable capacitor according to the test results. Sometimes, even no RF filtering capacitor is required.

In order to decrease radio or other signal interference, place RF antennas away from audio interfaces and audio traces. Additionally, keep power traces far away from the audio traces and do not route them in parallel.

Route the differential audio traces according to the differential signal layout rule.

3.23. USB_BOOT

USB_BOOT is an emergency download interface. You can force the module to enter emergency download mode by pulling it up to LDO15A_1V8 when the module is turning on. This is an emergency option when failures such as abnormal start-up or running occur. For firmware upgrade and debugging in the future, reserve the following reference design.

Table 27: Pin Definition of USB_BOOT Interface

Pin Name	Pin No.	I/O	Description	Comment
USB_BOOT	46	DI	Force the module into emergency download mode	Force the module to enter emergency download mode by pulling this pin up to LDO15A_1V8 when the module is turning on.

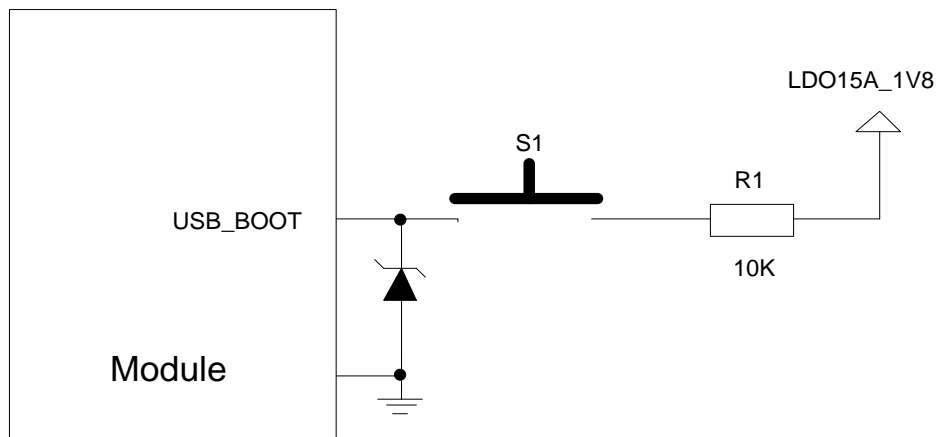

Figure 28: Reference Circuit Design for Emergency Download Interface

4 Wi-Fi/Bluetooth

The module provides a shared antenna interface ANT_WIFI/BT for Wi-Fi and Bluetooth functions. The interface impedance should be controlled to 50 Ω. You can connect external antennas such as PCB antenna, sucker antenna, and ceramic antenna to the module via the interface to achieve Wi-Fi and Bluetooth functions. Bluetooth and WLAN (both 5G and 2.4 G) are operating in TDD under coex mode.

4.1. Wi-Fi

The module supports 2.4 GHz and 5 GHz dual-band WLAN based on IEEE 802.11a/b/g/n/ac standard protocols. The maximum data rate is up to 150 Mbps in 2.4 GHz bands, and 433 Mbps in 5 GHz bands. The features are as below:

- Supports Wake-on-WLAN (WoWLAN)
- Supports ad hoc mode
- Supports WAPI SMS4 hardware encryption
- Supports AP and STA mode
- Supports Wi-Fi Direct
- Supports MCS 0–7 for HT20 and HT40
- Supports MCS 0–8 for VHT20
- Supports MCS 0–9 for VHT40 and VHT80

4.1.1. Wi-Fi Performance

The following table lists the Wi-Fi transmitting and receiving performance of the module.

Table 28: Wi-Fi Transmitting Performance

Frequency Bands	Standard	Rate	Output Power
2.4 GHz	802.11b	1 Mbps	16.5 dBm ±3 dB
	802.11b	11 Mbps	16.5 dBm ±3 dB
	802.11g	6 Mbps	16.5 dBm ±3 dB

	802.11g	54 Mbps	14.5 dBm ±3 dB
	802.11n HT20	MCS0	15 dBm ±3 dB
	802.11n HT20	MCS7	14.5 dBm ±3 dB
	802.11n HT40	MCS0	15 dBm ±3 dB
	802.11n HT40	MCS7	13.5 dBm ±3 dB
5 GHz	802.11a	6 Mbps	15.5 dBm ±3 dB
	802.11a	54 Mbps	13 dBm ±3 dB
	802.11n HT20	MCS0	15.5 dBm ±3 dB
	802.11n HT20	MCS7	13 dBm ±3 dB
	802.11n HT40	MCS0	15.5 dBm ±3 dB
	802.11n HT40	MCS7	13 dBm ±3 dB
	802.11ac VHT20	MCS0	15.5 dBm ±3 dB
	802.11ac VHT20	MCS8	12.5 dBm ±3 dB
	802.11ac VHT40	MCS0	15 dBm ±3 dB
	802.11ac VHT40	MCS9	12 dBm ±3 dB
	802.11ac VHT80	MCS0	14.5 dBm ±3 dB
	802.11ac VHT80	MCS9	11 dBm ±3 dB

Table 29: Wi-Fi Receiving Performance

Frequency Bands	Standard	Rate	Sensitivity
2.4 GHz	802.11b	1 Mbps	-96 dBm
	802.11b	11 Mbps	-87 dBm
	802.11g	6 Mbps	-90 dBm
	802.11g	54 Mbps	-74 dBm
	802.11n HT20	MCS0	-90 dBm

	802.11n HT20	MCS7	-71 dBm
	802.11n HT40	MCS0	-87 dBm
	802.11n HT40	MCS7	-70 dBm
5 GHz	802.11a	6 Mbps	-90 dBm
	802.11a	54 Mbps	-74 dBm
	802.11n HT20	MCS0	-90 dBm
	802.11n HT20	MCS7	-70 dBm
	802.11n HT40	MCS0	-87 dBm
	802.11n HT40	MCS7	-68 dBm
	802.11ac VHT20	MCS0	-90 dBm
	802.11ac VHT20	MCS8	-68 dBm
	802.11ac VHT40	MCS0	-87 dBm
	802.11ac VHT40	MCS9	-63 dBm
	802.11ac VHT80	MCS0	-83 dBm
	802.11ac VHT80	MCS9	-59 dBm

Reference specifications are listed below:

- *IEEE 802.11n WLAN MAC and PHY, October 2009 + IEEE 802.11-2007 WLAN MAC and PHY, June 2007*
- *IEEE Std 802.11a, IEEE Std 802.11b, IEEE Std 802.11g: IEEE 802.11-2007 WLAN MAC and PHY, June 2007*

4.2. Bluetooth

The module supports Bluetooth 5.0 (BR/EDR + BLE) specification, as well as GFSK, 8-DPSK, $\pi/4$ -DQPSK modulation modes.

- Maximally supports up to 7 wireless connections.
- Maximally supports up to 3.5 piconets at the same time.
- Support one SCO or eSCO connection.

The BR/EDR channel bandwidth is 1 MHz, and can accommodate 79 channels. The BLE channel bandwidth is 2 MHz, and can accommodate 40 channels.

Table 30: Bluetooth Data Rate and Version

Version	Data Rate	Maximum Application Throughput
1.2	1 Mbit/s	> 80 kbit/s
2.0 + EDR	3 Mbit/s	> 80 kbit/s
3.0 + HS	24 Mbit/s	Reference 3.0 + HS
4.0	24 Mbit/s	Reference 4.0 LE
5.0	24 Mbit/s	Reference 5.0 LE

Reference specifications are listed below:

- *Bluetooth Radio Frequency TSS and TP Specification 1.2/2.0/2.0 + EDR/2.1/2.1 + EDR/3.0/3.0 + HS, August 6, 2009*
- *Bluetooth Low Energy RF PHY Test Specification, RF-PHY.TS/4.0.0, December 15, 2009*

4.2.1. Bluetooth Performance

The following table lists the Bluetooth transmitting and receiving performance of the module.

Table 31: Bluetooth Transmitting and Receiving Performance

Transmitter Performance			
Packet Types	DH5	2-DH5	3-DH5
Transmitting Power	7 dBm ±3 dB	6.5 dBm ±3 dB	6.5 dBm ±3 dB
Receiver Performance			
Packet Types	DH5	2-DH5	3-DH5
Receiving Sensitivity	-93 dBm	-93 dBm	-86 dBm

5 GNSS

The module integrates a IZat™ GNSS engine (GEN 8C) which supports multiple positioning and navigation systems including GPS, GLONASS, Galileo, BDS, QZSS, SBAS and NavIC ⁵. With an embedded LNA, the positioning accuracy of the module has been significantly improved.

5.1. GNSS Performance

The following table lists the GNSS performance of the module in conduction mode.

Table 32: GNSS Performance

Parameter	Description	Typ.	Unit
Sensitivity	Acquisition	-147	dBm
	Reacquisition	-159	dBm
	Tracking	-159	dBm
TTFF	Cold start	31.2	s
	Warm start	24.7	s
	Hot start	1.32	s
Accuracy	CEP-50	1.95	m

NOTE

1. Tracking sensitivity: the minimum GNSS signal power at which the module can maintain lock (keep positioning for at least 3 minutes continuously).
2. Reacquisition sensitivity: the minimum GNSS signal power required for the module to maintain lock within 3 minutes after loss of lock.
3. Acquisition sensitivity: the minimum GNSS signal power at which the module can fix position successfully within 3 minutes after executing cold start command.

⁵ SC206E-WF does not support GNSS and NavIC is supported by SC206E-NA only.

5.2. GNSS RF Design Guidelines

Bad design of antenna and layout may cause reduced GNSS receiving sensitivity, longer GNSS positioning time, or reduced positioning accuracy. In order to avoid this, follow the reference design rules as below:

- Maximize the distance between the GNSS RF part and the GPRS RF part (including trace routing and antenna layout) to avoid mutual interference.
- In user systems, place GNSS RF signal lines and RF components far away from high-speed circuits, switch-mode power supplies, power inductors, the clock circuit of single-chip microcomputers, etc.
- For applications with harsh electromagnetic environment or high ESD-protection requirements, it is recommended to add ESD protective diodes for the antenna interface. The junction capacitance of the diodes should be less than 0.5 pF. Otherwise, it will influence the impedance characteristic of RF circuit loop, or cause attenuation of bypass RF signals.
- Control the impedance of feeder lines and PCB traces to 50 Ω , and keep the trace as short as possible.
- See **Chapter 6.3** for reference circuit designs of GNSS antenna.

6 Antenna Interfaces

SC206E-CE/EM/NA provides four antenna interfaces for the main, Rx-diversity, Wi-Fi/Bluetooth, and GNSS antennas respectively, while SC206E-WF provides one antenna interface for Wi-Fi/Bluetooth antenna only. The impedance of the antenna ports should be controlled to 50 Ω.

6.1. Main Antenna and Rx-diversity Antenna Interfaces

Table 33: Pin Definition of Main/Rx-diversity Antenna Interfaces

Pin Name	Pin No.	I/O	Description	Comment
ANT_MAIN	87	AIO	Main antenna interface	50 Ω impedance
ANT_DRX	131	AI	Diversity antenna interface	

6.1.1. Operating Frequency

The operating frequencies of the modules are listed in the following tables.

Table 34: SC206E-CE Operating Frequency

3GPP Bands	Receive	Transmit	Unit
EGSM900	925–960	880–915	MHz
DCS1800	1805–1880	1710–1785	MHz
WCDMA B1	2110–2170	1920–1980	MHz
WCDMA B8	925–960	880–915	MHz
EV-DO/CDMA BC0	869–894	824–849	MHz
LTE-FDD B1	2110–2170	1920–1980	MHz

LTE-FDD B3	1805–1880	1710–1785	MHz
LTE-FDD B5	869–894	824–849	MHz
LTE-FDD B8	925–960	880–915	MHz
LTE-TDD B34	2010–2025	2010–2025	MHz
LTE-TDD B38	2570–2620	2570–2620	MHz
LTE-TDD B39	1880–1920	1880–1920	MHz
LTE-TDD B40	2300–2400	2300–2400	MHz
LTE-TDD B41	2535–2675	2535–2675	MHz

Table 35: SC206E-EM Operating Frequency

3GPP Bands	Receive	Transmit	Unit
GSM850	869–894	824–849	MHz
EGSM900	925–960	880–915	MHz
DCS1800	1805–1880	1710–1785	MHz
PCS1900	1930–1990	1850–1910	MHz
WCDMA B1	2110–2170	1920–1980	MHz
WCDMA B2	1930–1990	1850–1910	MHz
WCDMA B4	2110–2155	1710–1755	MHz
WCDMA B5	869–894	824–849	MHz
WCDMA B8	925–960	880–915	MHz
LTE-FDD B1	2110–2170	1920–1980	MHz
LTE-FDD B2	1930–1990	1850–1910	MHz
LTE-FDD B3	1805–1880	1710–1785	MHz
LTE-FDD B4	2110–2155	1710–1755	MHz
LTE-FDD B5	869–894	824–849	MHz

LTE-FDD B7	2620–2690	2500–2570	MHz
LTE-FDD B8	925–960	880–915	MHz
LTE-FDD B20	791–821	832–862	MHz
LTE-FDD B28	758–803	703–748	MHz
LTE-TDD B38	2570–2620	2570–2620	MHz
LTE-TDD B40	2300–2400	2300–2400	MHz
LTE-TDD B41	2496–2690	2496–2690	MHz

Table 36: SC206E-NA Operating Frequency

3GPP Bands	Receive	Transmit	Unit
LTE-FDD B2	1930–1990	1850–1910	MHz
LTE-FDD B4	2110–2155	1710–1755	MHz
LTE-FDD B5	869–894	824–849	MHz
LTE-FDD B7	2620–2690	2500–2570	MHz
LTE-FDD B12	729–746	699–716	MHz
LTE-FDD B13	746–756	777–787	MHz
LTE-FDD B14	758–768	788–798	MHz
LTE-FDD B17	734–746	704–716	MHz
LTE-FDD B25	1930–1995	1850–1915	MHz
LTE-FDD B26	859–894	814–849	MHz
LTE-FDD B66	2110–2180	1710–1780	MHz
LTE-FDD B71	617–652	663–698	MHz
LTE-TDD B41	2496–2690	2496–2690	MHz

6.1.2. Reference Design

A reference circuit design for the main and Rx-diversity antenna interfaces is shown below. Reserve a π -type matching circuit for each antenna to achieve better RF performance, and place the π -type matching components (R1/C1/C2 and R2/C3/C4) as close to the antennas as possible. The capacitors are not mounted by default and the resistors are 0 Ω .

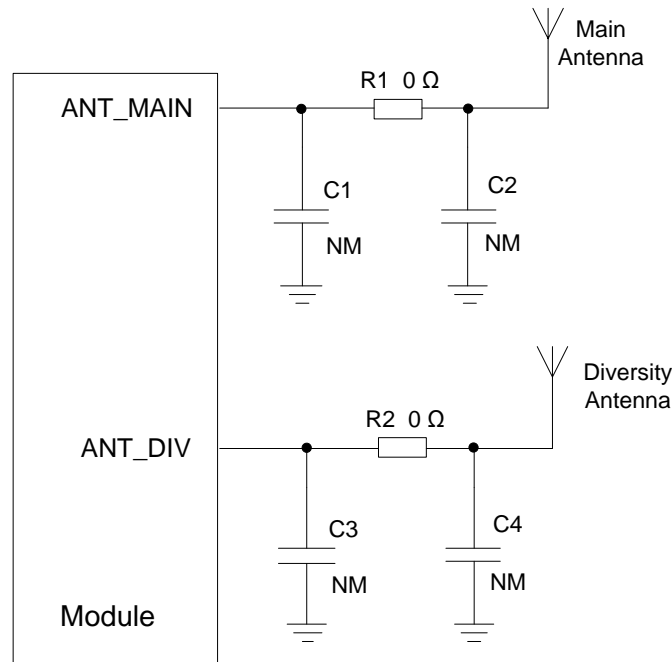

Figure 29: Reference Circuit Design for Main and Rx-diversity Antenna Interfaces

6.2. Wi-Fi/Bluetooth Antenna Interface

The following tables show the pin definition and frequency specification of the Wi-Fi/Bluetooth antenna interface.

Table 37: Pin Definition of Wi-Fi/Bluetooth Antenna Interface

Pin Name	Pin No.	I/O	Description	Comment
ANT_WIFI/BT	77	AIO	Wi-Fi/Bluetooth antenna interface	50 Ω impedance

Table 38: Wi-Fi/Bluetooth Frequency

Type	Frequency	Unit
Wi-Fi (2.4 GHz)	2402–2482	MHz
Wi-Fi (5 GHz)	5180–5825	MHz
Bluetooth 5.0	2402–2480	MHz

A reference circuit design for Wi-Fi/Bluetooth antenna interface is shown as below. C1 and C2 are not mounted by default and the resistor is 0 Ω.

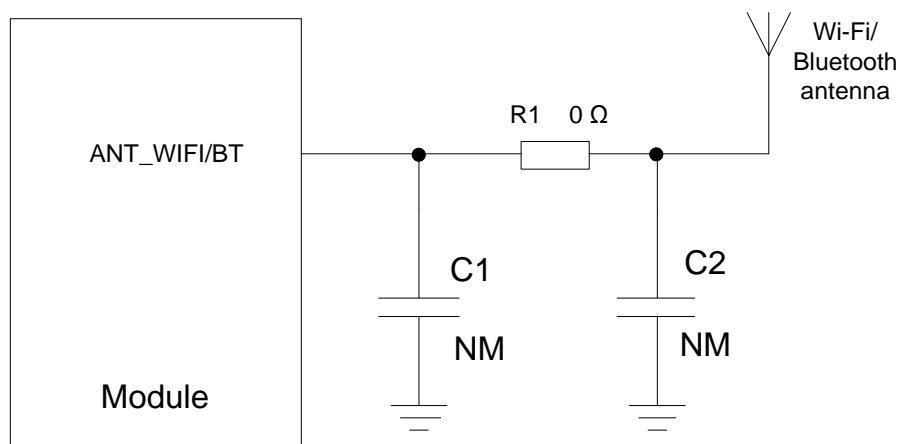

Figure 30: Reference Circuit Design for Wi-Fi/Bluetooth Antenna

6.3. GNSS Antenna Interface

The following tables show the pin definition and frequency specification of GNSS antenna interface.

Table 39: Pin Definition of GNSS Antenna Interface

Pin Name	Pin No.	I/O	Description	Comment
ANT_GNSS	121	AI	GNSS antenna interface	50 Ω impedance

Table 40: GNSS Frequency

Type	Frequency	Unit
GPS L1	1575.42 ±1.023	MHz
GPS L5	1176.45 ±10.23	MHz
GLONASS L1	1597.5–1605.8	MHz
BDS B1I	1561.098 ±2.046	MHz
Galileo E1	1575.42 ±2.046	MHz
Galileo E5a	1176.45 ±10.23	MHz
QZSS L1	1575.42 ±1.023	MHz
QZSS L5	1176.45 ±10.23	MHz
SBAS L1	1575.42 ±1.023	MHz
SBAS L5	1176.45 ±10.23	MHz
NavIC L5	1176.45 ±10.23	MHz

6.3.1. Reference Circuit Design for Passive GNSS Antenna

GNSS antenna interface supports passive ceramic antennas and other types of passive antennas. A reference circuit design is given below.

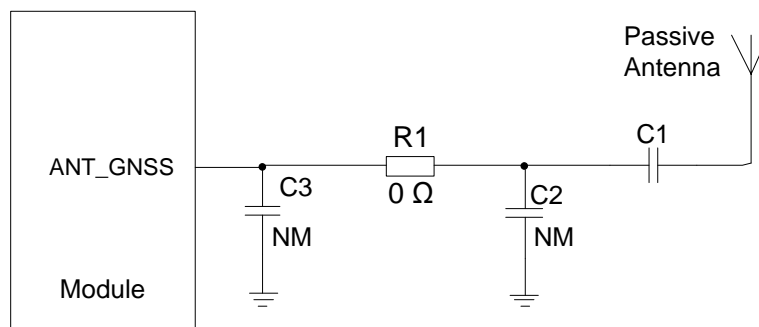

Figure 31: Reference Circuit Design for Passive GNSS Antenna

NOTE

It is not recommended to add an external LNA when using a passive GNSS antenna.

6.3.2. Reference Circuit Design for Active GNSS Antenna

The active antenna is powered by a 56 nH inductor through the antenna's signal path. The common power supply voltage ranges from 3.3 V to 5.0 V. Despite its low power consumption, the active antenna still requires stable and clean power supplies. Therefore, it is recommended to use high-performance LDO as the power supply. A reference design for active GNSS antenna is shown below.

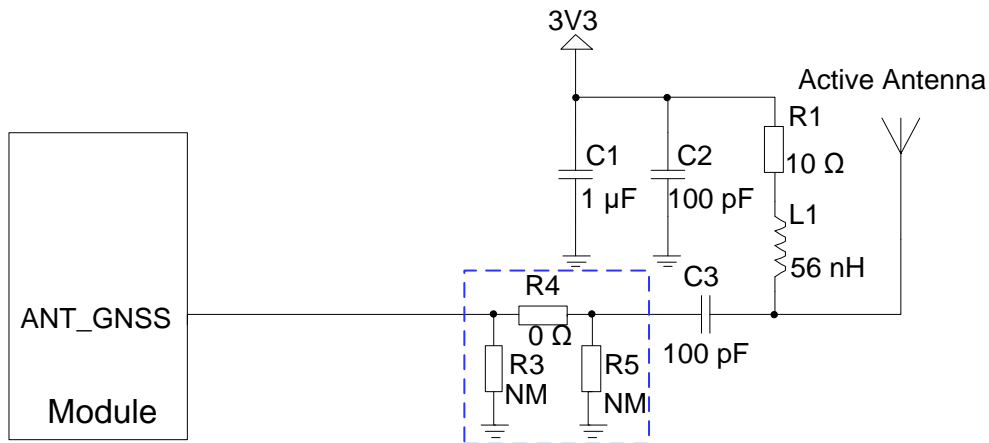

Figure 32: Reference Circuit Design for Active GNSS Antenna

NOTE

It is recommended to use a passive antenna. If active antennas are required, it is strongly recommended to reserve a π -type attenuation and ensure that the total gain of the external GNSS RF path of the module is not greater than 0 dB. At the same time, this may compromise the GNSS performance, depending on the performance of the active antenna.

6.4. RF Routing Guidelines

For user's PCB, the characteristic impedance of all RF traces should be controlled to 50 Ω . The impedance of the RF traces is usually determined by the trace width (W), the materials' dielectric constant, the height from the reference ground to the signal layer (H), and the spacing between RF traces and grounds (S). Microstrip or coplanar waveguide is typically used in RF layout to control characteristic impedance. The following are reference designs of microstrip or coplanar waveguide with different PCB structures.

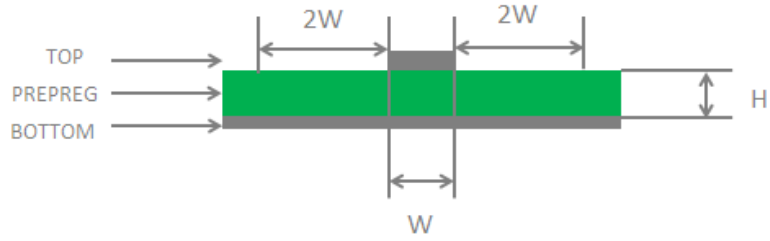

Figure 33: Microstrip Design on a 2-layer PCB

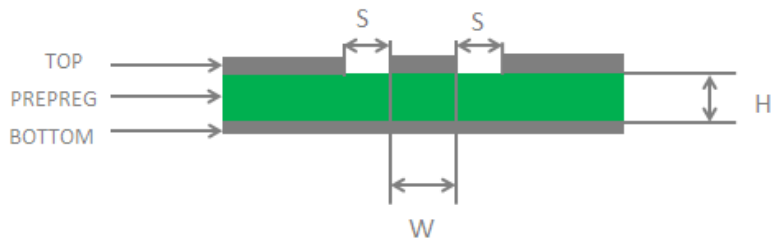

Figure 34: Coplanar Waveguide Design on a 2-layer PCB

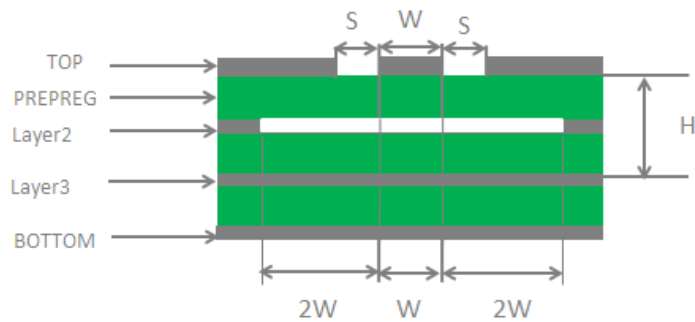

Figure 35: Coplanar Waveguide Design on a 4-layer PCB (Layer 3 as Reference Ground)

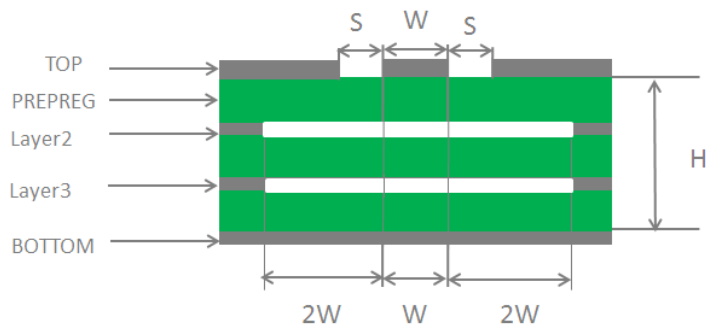

Figure 36: Coplanar Waveguide Design on a 4-layer PCB (Layer 4 as Reference Ground)

In order to ensure RF performance and reliability, follow the principles below in RF layout design:

- Use an impedance simulation tool to accurately control the characteristic impedance of RF traces to 50 Ω.
- The GND pins adjacent to RF pins should not be designed as thermal relief pads, and should be fully connected to ground.
- The distance between the RF pins and the RF connector should be as short as possible and all the right-angle traces should be changed to curved ones. The recommended trace angle is 135°.
- There should be clearance under the signal pin of the antenna connector or solder joint.
- The reference ground of RF traces should be complete. Meanwhile, adding some ground vias around RF traces and the reference ground could help to improve RF performance. The distance between the ground vias and RF traces should be no less than two times the width of RF signal traces (2 × W).
- Keep RF traces away from interference sources, and avoid intersection and paralleling between traces on adjacent layers.

For more details about RF layout, see **document [3]**.

6.5. Antenna Installation

6.5.1. Antenna Requirements

The following table shows the requirements for the main antenna, Rx-diversity antenna, Wi-Fi/Bluetooth antenna, and GNSS antenna.

Table 41: Antenna Requirements

Type	Requirements
GSM/WCDMA/LTE	VSWR: ≤ 2 Gain: 1 dBi Max Input Power: 50 W Input Impedance: 50 Ω Polarization Type: Vertical Cable insertion loss: <ul style="list-style-type: none"> ● < 1 dB: LB (< 1 GHz) ● < 1.5 dB: MB (1–2.3 GHz) ● < 2 dB: HB (> 2.3 GHz)
Wi-Fi/Bluetooth	VSWR: ≤ 2 Gain: 1 dBi Max Input Power: 50 W Input Impedance: 50 Ω

	Polarization Type: Vertical Cable Insertion Loss: < 1 dB
GNSS	Frequency range (L1): 1559–1609 MHz Frequency range (L5): 1166–1187 MHz (SC206E-NA only) Polarization: RHCP or linear VSWR: < 2 (Typ.) Passive antenna gain: > 0 dBi Active antenna noise figure: < 1.5 dB (Typ.) Active antenna gain: > -2 dBi Active antenna embedded LNA gain: < 17 dB (Typ.) Active antenna total gain: < 17 dBi (Typ.) Total gain of the GNSS RF trace outside the module: ≤ 0 dB (Typ.)

NOTE

It is recommended to use a passive GNSS antenna when LTE B13 or B14 is supported, as the use of active antenna may generate harmonics which will affect the GNSS performance.

6.5.2. RF Connector Recommendation

If you use an RF connector for antenna connection, it is recommended to use the U.FL-R-SMT receptacle provided by Hirose.

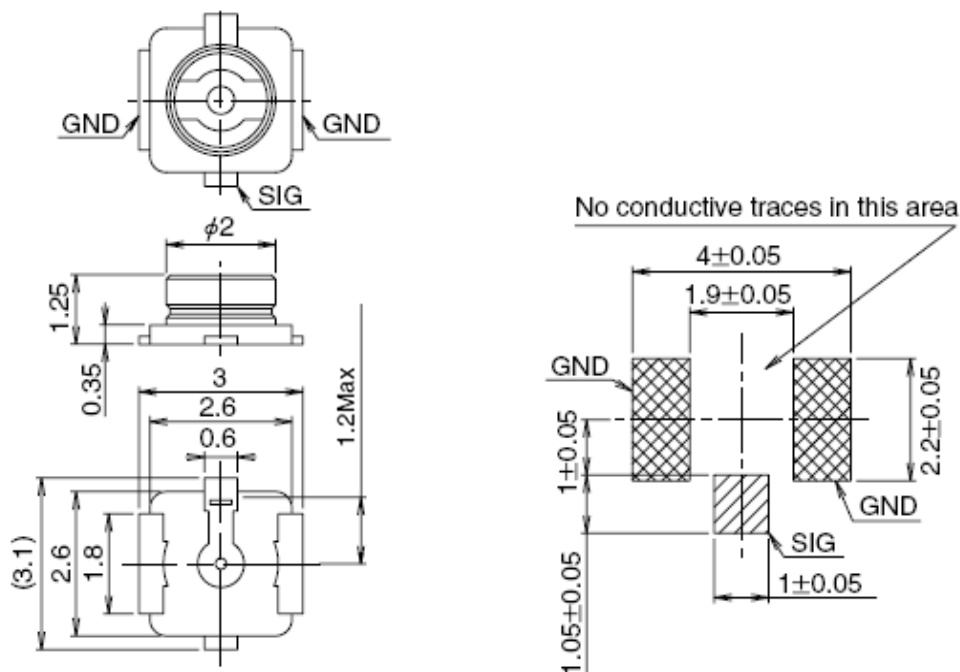

Figure 37: Dimensions of the U.FL-R-SMT Receptacle (Unit: mm)

U.FL-LP serial plugs listed in the following figure can be used to match U.FL-R-SMT.

Part No.	U.FL-LP-040	U.FL-LP-066	U.FL-LP(V)-040	U.FL-LP-062	U.FL-LP-088
Mated Height	2.5mm Max. (2.4mm Nom.)	2.5mm Max. (2.4mm Nom.)	2.0mm Max. (1.9mm Nom.)	2.4mm Max. (2.3mm Nom.)	2.4mm Max. (2.3mm Nom.)
Applicable cable	Dia. 0.81mm Coaxial cable	Dia. 1.13mm and Dia. 1.32mm Coaxial cable	Dia. 0.81mm Coaxial cable	Dia. 1mm Coaxial cable	Dia. 1.37mm Coaxial cable
Weight (mg)	53.7	59.1	34.8	45.5	71.7
RoHS	YES				

Figure 38: Mechanicals of U.FL-LP Plugs

The following figure describes the space factor of mated connectors.

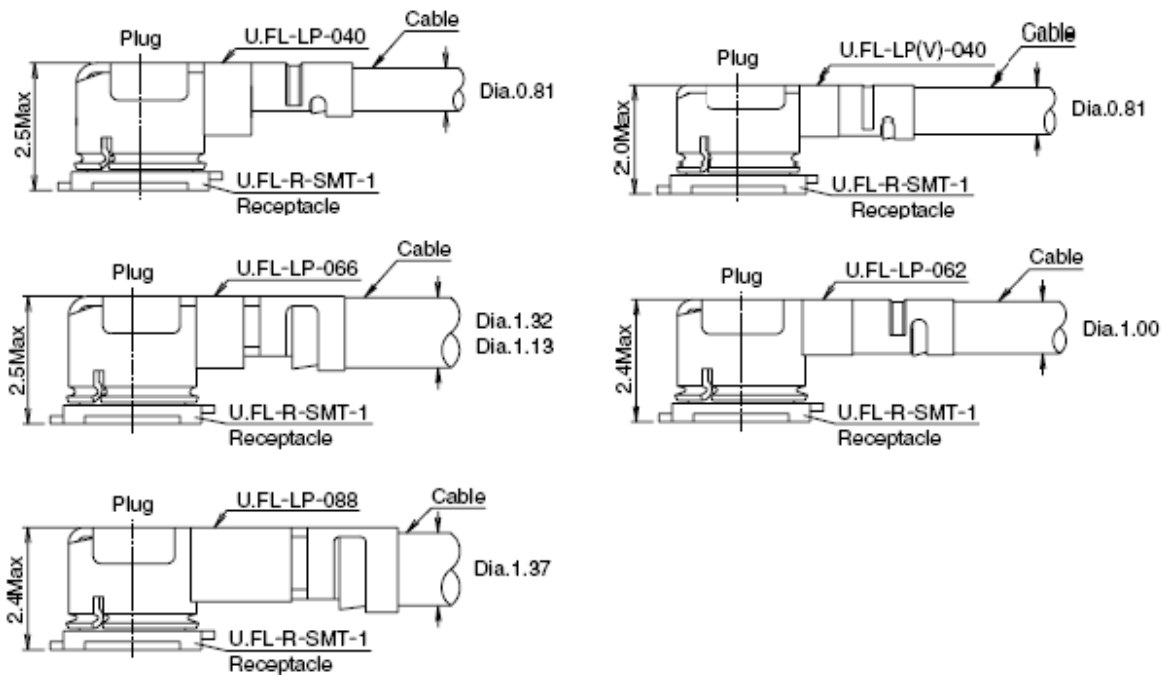

Figure 39: Space Factor of Mated Connectors (Unit: mm)

For more details, visit <http://www.hirose.com>.

7 Reliability, Radio and Electrical Characteristics

7.1. Absolute Maximum Ratings

Absolute maximum ratings for power supply and voltage on digital and analog pins of the module are listed in the following table.

Table 42: Absolute Maximum Ratings

Parameter	Min.	Max.	Unit
VBAT	-0.5	6	V
USB_VBUS	-0.5	16	V
Peak Current of VBAT	-	3	A
Voltage on Digital Pins	-0.3	2.16	V

7.2. Power Supply Ratings

Table 43: Power Supply Ratings

Parameter	Description	Conditions	Min.	Typ.	Max.	Unit
VBAT	VBAT	The actual input voltages must stay between the minimum and maximum values	3.5	3.8	4.4	V
	Voltage drop during transmitting burst	Maximum power control level at EGSM900	-	-	400	mV
IVBAT	Peak supply current (during transmission slot)	Maximum power control level at EGSM900	-	1.8	3.0	A

USB_VBUS	Charging power input	-	4.0	5.0	6.0	V
----------	----------------------	---	-----	-----	-----	---

7.3. Digital I/O Characteristics

Table 44: 1.8 V Digital I/O Requirements

Parameter	Description	Min.	Max.	Unit
V _{IH}	Input high voltage	1.17	2.1	V
V _{IL}	Input low voltage	-0.3	0.63	V
V _{OH}	Output high voltage	1.35	1.8	V
V _{OL}	Output low voltage	0	0.45	V

Table 45: (U)SIM 1.8 V I/O Requirements

Parameter	Description	Min.	Max.	Unit
USIM_VDD	Power supply	1.75	1.85	V
V _{IH}	Input high voltage	1.26	2.1	V
V _{IL}	Input low voltage	-0.3	0.36	V
V _{OH}	Output high voltage	1.44	1.8	V
V _{OL}	Output low voltage	0	0.4	V

Table 46: (U)SIM 2.95 V I/O Requirements

Parameter	Description	Min.	Max.	Unit
USIM_VDD	Power supply	2.8	3.1	V
V _{IH}	Input high voltage	2.065	3.25	V
V _{IL}	Input low voltage	-0.3	0.59	V

V_{OH}	Output high voltage	2.36	2.95	V
V_{OL}	Output low voltage	0	0.4	V

Table 47: SD Card 1.8 V I/O Requirements

Parameter	Description	Min.	Max.	Unit
V_{IH}	Input high voltage	1.27	2	V
V_{IL}	Input low voltage	-0.3	0.58	V
V_{OH}	Output high voltage	1.4	-	V
V_{OL}	Output low voltage	-	0.45	V

Table 48: SD Card 2.95 V I/O Requirements

Parameter	Description	Min.	Max.	Unit
V_{IH}	Input high voltage	1.84	3.25	V
V_{IL}	Input low voltage	-0.3	0.74	V
V_{OH}	Output high voltage	2.21	2.95	V
V_{OL}	Output low voltage	0	0.37	V

7.4. Operating and Storage Temperatures

The operating and storage temperatures are listed in the following table.

Table 49: Operating and Storage Temperatures

Parameter	Min.	Typ.	Max.	Unit
Operating temperature range ⁶	-35	+25	+75	°C
Storage Temperature Range	-40	-	+90	°C

⁶ Within operating temperature range, the module meets 3GPP specifications.

7.5. Power Consumption

The values of current consumption are shown below.

Table 50: SC206E-CE Power Consumption

Description	Conditions	Typ.	Unit
OFF state	Power off	42	μA
GSM/GPRS supply current	Sleep state (USB disconnected) @ DRX = 2	4.93	mA
	Sleep state (USB disconnected) @ DRX = 5	4.26	mA
	Sleep state (USB disconnected) @ DRX = 9	3.85	mA
WCDMA supply current	Sleep state (USB disconnected) @ DRX = 6	4.65	mA
	Sleep state (USB disconnected) @ DRX = 7	4.21	mA
	Sleep state (USB disconnected) @ DRX = 8	4.11	mA
	Sleep state (USB disconnected) @ DRX = 9	3.87	mA
CDMA supply current	BC0 CH283 @ Slot Cycle Index = 1	4.94	mA
	BC0 CH283 @ Slot Cycle Index = 7	3.71	mA
LTE-FDD supply current	Sleep state (USB disconnected) @ DRX = 5	6.27	mA
	Sleep state (USB disconnected) @ DRX = 6	5	mA
	Sleep state (USB disconnected) @ DRX = 7	4.28	mA
	Sleep state (USB disconnected) @ DRX = 8	4.17	mA
LTE-TDD supply current	Sleep state (USB disconnected) @ DRX = 5	6.3	mA
	Sleep state (USB disconnected) @ DRX = 6	5.1	mA
	Sleep state (USB disconnected) @ DRX = 7	4.43	mA
	Sleep state (USB disconnected) @ DRX = 8	3.99	mA
GSM voice call	EGSM900 @ PCL 5	287	mA
	EGSM900 @ PCL 12	143	mA

	EGSM900 @ PCL 19	87	mA
	DCS1800 @ PCL 0	190	mA
	DCS1800 @ PCL 7	137	mA
	DCS1800 @ PCL 15	85	mA
WCDMA voice call	B1 @ max. power	586	mA
	B8 @ max. power	640	mA
GPRS data transmission	EGSM900 (1UL/4DL) @ PCL 5	282	mA
	EGSM900 (2UL/3DL) @ PCL 5	451	mA
	EGSM900 (3UL/2DL) @ PCL 5	528	mA
	EGSM900 (4UL/1DL) @ PCL 5	613	mA
	DCS1800 (1UL/4DL) @ PCL 0	190	mA
	DCS1800 (2UL/3DL) @ PCL 0	297	mA
	DCS1800 (3UL/2DL) @ PCL 0	356	mA
	DCS1800 (4UL/1DL) @ PCL 0	439	mA
EDGE data transmission	EGSM900 (1UL/4DL) @ PCL 8	202	mA
	EGSM900 (2UL/3DL) @ PCL 8	326	mA
	EGSM900 (3UL/2DL) @ PCL 8	436	mA
	EGSM900 (4UL/1DL) @ PCL 8	556	mA
	DCS1800 (1UL/4DL) @ PCL 2	178	mA
	DCS1800 (2UL/3DL) @ PCL 2	278	mA
	DCS1800 (3UL/2DL) @ PCL 2	374	mA
	DCS1800 (4UL/1DL) @ PCL 2	476	mA
WCDMA data transmission	B1 (HSDPA) @ max power	552	mA
	B8 (HSDPA) @ max power	596	mA
	B1 (HSUPA) @ max power	573	mA

	B8 (HSUPA) @ max power	614	mA
EV-DO/CDMA data transmission	BC0 @ max power	614	mA
	LTE-FDD B1 @ max power	654	mA
	LTE-FDD B3 @ max power	653	mA
	LTE-FDD B5 @ max power	587	mA
	LTE-FDD B8 @ max power	638	mA
LTE data transmission	LTE-TDD B34 @ max power	307	mA
	LTE-TDD B38 @ max power	407	mA
	LTE-TDD B39 @ max power	325	mA
	LTE-TDD B40 @ max power	401	mA
	LTE-TDD B41 @ max power	433	mA

Table 51: SC206E-EM Power Consumption

Description	Conditions	Typ.	Unit
OFF state	Power off	39	μA
GSM/GPRS supply current	Sleep state (USB disconnected) @ DRX = 2	4.99	mA
	Sleep state (USB disconnected) @ DRX = 5	4.24	mA
	Sleep state (USB disconnected) @ DRX = 9	4.01	mA
WCDMA supply current	Sleep state (USB disconnected) @ DRX = 6	4.57	mA
	Sleep state (USB disconnected) @ DRX = 7	4.17	mA
	Sleep state (USB disconnected) @ DRX = 8	3.97	mA
	Sleep state (USB disconnected) @ DRX = 9	3.85	mA
LTE-FDD supply current	Sleep state (USB disconnected) @ DRX = 5	6.26	mA
	Sleep state (USB disconnected) @ DRX = 6	4.98	mA
	Sleep state (USB disconnected) @ DRX = 7	4.31	mA
	Sleep state (USB disconnected) @ DRX = 8	4.01	mA

LTE-TDD supply current	Sleep state (USB disconnected) @ DRX = 5	6.36	mA
	Sleep state (USB disconnected) @ DRX = 6	5.03	mA
	Sleep state (USB disconnected) @ DRX = 7	4.38	mA
	Sleep state (USB disconnected) @ DRX = 8	4.02	mA
GSM voice call	GSM850 @ PCL 5	274	mA
	GSM850 @ PCL 12	139	mA
	GSM850 @ PCL 19	83	mA
	EGSM900 @ PCL 5	291	mA
	EGSM900 @ PCL 12	138	mA
	EGSM900 @ PCL 19	83	mA
	DCS1800 @ PCL 0	181	mA
	DCS1800 @ PCL 7	133	mA
	DCS1800 @ PCL 15	81	mA
	PCS1900 @ PCL 0	190	mA
	PCS1900 @ PCL 7	135	mA
	PCS1900 @ PCL 15	81	mA
WCDMA voice call	B1 @ max power	590	mA
	B2 @ max power	590	mA
	B4 @ max power	630	mA
	B5 @ max power	550	mA
	B8 @ max power	630	mA
GPRS data transmission	GSM850 (1UL/4DL) @ PCL 5	267	mA
	GSM850 (2UL/3DL) @ PCL 5	417	mA
	GSM850 (3UL/2DL) @ PCL 5	490	mA
	GSM850 (4UL/1DL) @ PCL 5	579	mA
	EGSM900 (1UL/4DL) @ PCL 5	287	mA
	EGSM900 (2UL/3DL) @ PCL 5	451	mA

	EGSM900 (3UL/2DL) @ PCL 5	524	mA
	EGSM900 (4UL/1DL) @ PCL 5	617	mA
	DCS1800 (1UL/4DL) @ PCL 0	188	mA
	DCS1800 (2UL/3DL) @ PCL 0	277	mA
	DCS1800 (3UL/2DL) @ PCL 0	344	mA
	DCS1800 (4UL/1DL) @ PCL 0	426	mA
	PCS1900 (1UL/4DL) @ PCL 0	193	mA
	PCS1900 (2UL/3DL) @ PCL 0	291	mA
	PCS1900 (3UL/2DL) @ PCL 0	352	mA
	PCS1900 (4UL/1DL) @ PCL 0	435	mA
EDGE data transmission	GSM850 (1UL/4DL) @ PCL 8	194	mA
	GSM850 (2UL/3DL) @ PCL 8	318	mA
	GSM850 (3UL/2DL) @ PCL 8	430	mA
	GSM850 (4UL/1DL) @ PCL 8	550	mA
	EGSM900 (1UL/4DL) @ PCL 8	200	mA
	EGSM900 (2UL/3DL) @ PCL 8	325	mA
	EGSM900 (3UL/2DL) @ PCL 8	438	mA
	EGSM900 (4UL/1DL) @ PCL 8	554	mA
	DCS1800 (1UL/4DL) @ PCL 2	173	mA
	DCS1800 (2UL/3DL) @ PCL 2	275	mA
	DCS1800 (3UL/2DL) @ PCL 2	376	mA
	DCS1800 (4UL/1DL) @ PCL 2	491	mA
	PCS1900 (1UL/4DL) @ PCL 2	171	mA
	PCS1900 (2UL/3DL) @ PCL 2	274	mA
	PCS1900 (3UL/2DL) @ PCL 2	373	mA
	PCS1900 (4UL/1DL) @ PCL 2	480	mA
WCDMA data transmission	B1 (HSDPA) @ max power	560	mA

	B2 (HSDPA) @ max power	550	mA
	B4 (HSDPA) @ max power	590	mA
	B5 (HSDPA) @ max power	515	mA
	B8 (HSDPA) @ max power	610	mA
	B1 (HSUPA) @ max power	575	mA
	B2 (HSUPA) @ max power	565	mA
	B4 (HSUPA) @ max power	600	mA
	B5 (HSUPA) @ max power	530	mA
	B8 (HSUPA) @ max power	600	mA
LTE data transmission	LTE-FDD B1 @ max power	645	mA
	LTE-FDD B2 @ max power	600	mA
	LTE-FDD B3 @ max power	630	mA
	LTE-FDD B4 @ max power	670	mA
	LTE-FDD B5 @ max power	580	mA
	LTE-FDD B7 @ max power	650	mA
	LTE-FDD B8 @ max power	585	mA
	LTE-FDD B20 @ max power	605	mA
	LTE-FDD B28 @ max power	570	mA
	LTE-TDD B38 @ max power	370	mA
	LTE-TDD B40 @ max power	370	mA
	LTE-TDD B41 @ max power	400	mA

Table 52: SC206E-NA Power Consumption

Description	Conditions	Typ.	Unit
OFF state	Power off	36.0	μA
LTE-FDD supply current	Sleep state (USB disconnected) @ DRX = 5	6.25	mA

	Sleep state (USB disconnected) @ DRX = 6	4.85	mA
	Sleep state (USB disconnected) @ DRX = 7	4.19	mA
	Sleep state (USB disconnected) @ DRX = 8	3.96	mA
LTE-TDD supply current	Sleep state (USB disconnected) @ DRX = 5	6.34	mA
	Sleep state (USB disconnected) @ DRX = 6	5.07	mA
	Sleep state (USB disconnected) @ DRX = 7	4.33	mA
	Sleep state (USB disconnected) @ DRX = 8	4.04	mA
LTE data transmission	LTE-FDD B2 @ max power	671	mA
	LTE-FDD B4 @ max power	649	mA
	LTE-FDD B5 @ max power	670	mA
	LTE-FDD B7 @ max power	822	mA
	LTE-FDD B12 @ max power	722	mA
	LTE-FDD B13 @ max power	742	mA
	LTE-FDD B14 @ max power	639	mA
	LTE-FDD B17 @ max power	705	mA
	LTE-FDD B25 @ max power	707	mA
	LTE-FDD B26 @ max power	660	mA
	LTE-FDD B66 @ max power	673	mA
	LTE-FDD B71 @ max power	634	mA
	LTE-TDD B41 @ max power	423	mA

7.6. Tx Power

The following tables show the RF output power of the module.

Table 53: SC206E-CE RF Tx Power

Frequency Bands	Max. RF Output Power	Min. RF Output Power
-----------------	----------------------	----------------------

EGSM900	33 dBm \pm 2 dB	5 dBm \pm 5 dB
DCS1800	30 dBm \pm 2 dB	0 dBm \pm 5 dB
WCDMA B1	24 dBm +1/-3 dB	< -49 dBm
WCDMA B8	24 dBm +1/-3 dB	< -49 dBm
EV-DO/CDMA BC0	24 dBm +3/-1 dB	< -49 dBm
LTE-FDD B1	23 dBm \pm 2 dB	< -39 dBm
LTE-FDD B3	23 dBm \pm 2 dB	< -39 dBm
LTE-FDD B5	23 dBm \pm 2 dB	< -39 dBm
LTE-FDD B8	23 dBm \pm 2 dB	< -39 dBm
LTE-TDD B34	23 dBm \pm 2 dB	< -39 dBm
LTE-TDD B38	23 dBm \pm 2 dB	< -39 dBm
LTE-TDD B39	23 dBm \pm 2 dB	< -39 dBm
LTE-TDD B40	23 dBm \pm 2 dB	< -39 dBm
LTE-TDD B41	23 dBm \pm 2 dB	< -39 dBm

Table 54: SC206E-EM RF Tx Power

Frequency Bands	Max. RF Output Power	Min. RF Output Power
GSM850	33 dBm \pm 2 dB	5 dBm \pm 5 dB
EGSM900	33 dBm \pm 2 dB	5 dBm \pm 5 dB
DCS1800	30 dBm \pm 2 dB	0 dBm \pm 5 dB
PCS1900	30 dBm \pm 2 dB	0 dBm \pm 5 dB
WCDMA B1	24 dBm +1/-3 dB	< -49 dBm
WCDMA B2	24 dBm +1/-3 dB	< -49 dBm
WCDMA B4	24 dBm +1/-3 dB	< -49 dBm
WCDMA B5	24 dBm +1/-3 dB	< -49 dBm
WCDMA B8	24 dBm +1/-3 dB	< -49 dBm
LTE-FDD B1	23 dBm \pm 2 dB	< -39 dBm
LTE-FDD B2	23 dBm \pm 2 dB	< -39 dBm

LTE-FDD B3	23 dBm \pm 2 dB	< -39 dBm
LTE-FDD B4	23 dBm \pm 2 dB	< -39 dBm
LTE-FDD B5	23 dBm \pm 2 dB	< -39 dBm
LTE-FDD B7	23 dBm \pm 2 dB	< -39 dBm
LTE-FDD B8	23 dBm \pm 2 dB	< -39 dBm
LTE-FDD B20	23 dBm \pm 2 dB	< -39 dBm
LTE-FDD B28	23 dBm \pm 2 dB	< -39 dBm
LTE-TDD B38	23 dBm \pm 2 dB	< -39 dBm
LTE-TDD B40	23 dBm \pm 2 dB	< -39 dBm
LTE-TDD B41	23 dBm \pm 2 dB	< -39 dBm

Table 55: SC206E-NA RF Tx Power

Frequency Bands	Max. RF Output Power	Min. RF Output Power
LTE-FDD B2	23 dBm \pm 2 dB	< -39 dBm
LTE-FDD B4	23 dBm \pm 2 dB	< -39 dBm
LTE-FDD B5	23 dBm \pm 2 dB	< -39 dBm
LTE-FDD B7	23 dBm \pm 2 dB	< -39 dBm
LTE-FDD B12	23 dBm \pm 2 dB	< -39 dBm
LTE-FDD B13	23 dBm \pm 2 dB	< -39 dBm
LTE-FDD B14	23 dBm \pm 2 dB	< -39 dBm
LTE-FDD B17	23 dBm \pm 2 dB	< -39 dBm
LTE-FDD B25	23 dBm \pm 2 dB	< -39 dBm
LTE-FDD B26	23 dBm \pm 2 dB	< -39 dBm
LTE-FDD B66	23 dBm \pm 2 dB	< -39 dBm
LTE-FDD B71	23 dBm \pm 2 dB	< -39 dBm
LTE-TDD B41	23 dBm \pm 2 dB	< -39 dBm

NOTE

In GPRS and EDGE 4-slot Tx mode, the maximum output power is reduced by 3 dB. This design conforms to the GSM specification as described in *3GPP TS 51.010-1 subclause 13.16* and *subclause 13.17*.

7.7. Rx Sensitivity

The following table shows the RF receiving sensitivity of the module.

Table 56: SC206E-CE RF Rx Sensitivity

Frequency Bands	Receiving Sensitivity (dBm) (Typ.)			3GPP (SIMO)
	Primary	Diversity	SIMO	
EGSM900	-109.5	-	-	-102.4
DCS1800	-109	-	-	-102.4
WCDMA B1	-110.5	-112	TBD	-106.7
WCDMA B8	-111	-112	TBD	-103.7
EV-DO/CDMA BC0	-108.5	-	-	-104
LTE-FDD B1 (10 MHz)	-98	-100	-102	-96.3
LTE-FDD B3 (10 MHz)	-98.5	-98.5	-101.5	-93.3
LTE-FDD B5 (10 MHz)	-99.5	-99.5	-102.5	-94.3
LTE-FDD B8 (10 MHz)	-99	-100	-102.5	-93.3
LTE-TDD B34 (10 MHz)	-98	-99	-101.5	-96.3
LTE-TDD B38 (10 MHz)	-97	-98	-99.6	-96.3
LTE-TDD B39 (10 MHz)	-98	-99	-101.5	-96.3
LTE-TDD B40 (10 MHz)	-97.5	-98.5	-101	-96.3
LTE-TDD B41 (10 MHz)	-96	-98	-99.5	-94.3

Table 57: SC206E-EM RF Rx Sensitivity

Frequency Bands	Receiving Sensitivity (dBm) (Typ.)			3GPP (SIMO)
	Primary	Diversity	SIMO	

GSM850	-109.9			-102.4
EGSM900	-108.9			-102.4
DCS1800	-109.8			-102.4
PCS1900	-108.6			-102.4
WCDMA B1	-109.3	-111.2	TBD	-106.7
WCDMA B2	-109.2	-110.3	TBD	-104.7
WCDMA B4	-108.4	-111.2	TBD	-106.7
WCDMA B5	-111	-111	TBD	-104.7
WCDMA B8	-110.9	-112	TBD	-103.7
LTE-FDD B1 (10 MHz)	-97.5	-99	-101.5	-96.3
LTE-FDD B2 (10 MHz)	-97	-98	-100.5	-94.3
LTE-FDD B3 (10 MHz)	-98.5	-98	-101.5	-93.3
LTE-FDD B4 (10 MHz)	-97	-99	-101	-96.3
LTE-FDD B5 (10 MHz)	-99	-99.2	-102	-94.3
LTE-FDD B7 (10 MHz)	-97	-97.4	-100	-94.3
LTE-FDD B8 (10 MHz)	-99	-99.5	-102	-93.3
LTE-FDD B20 (10 MHz)	-99	-100	-102.5	-93.3
LTE-FDD B28 (10 MHz)	-99	-99.5	-102	-94.8
LTE-TDD B38 (10 MHz)	-97	-97	-100	-96.3
LTE-TDD B40 (10 MHz)	-97.5	-98.5	-100.5	-96.3
LTE-TDD B41 (10 MHz)	-96	-97	-99.5	-94.3

Table 58: SC206E-NA RF Rx Sensitivity

Frequency Bands	Receiving Sensitivity (dBm) (Typ.)			3GPP (SIMO)
	Primary	Diversity	SIMO	
LTE-FDD B2 (10 MHz)	TBD	TBD	TBD	-94.3
LTE-FDD B4 (10 MHz)	TBD	TBD	TBD	-96.3
LTE-FDD B5 (10 MHz)	TBD	TBD	TBD	-94.3

LTE-FDD B7 (10 MHz)	TBD	TBD	TBD	-94.3
LTE-FDD B12 (10 MHz)	TBD	TBD	TBD	-93.3
LTE-FDD B13 (10 MHz)	TBD	TBD	TBD	-93.3
LTE-FDD B14 (10 MHz)	TBD	TBD	TBD	-93.3
LTE-FDD B17 (10 MHz)	TBD	TBD	TBD	-93.3
LTE-FDD B25 (10 MHz)	TBD	TBD	TBD	-92.8
LTE-FDD B26 (10 MHz)	TBD	TBD	TBD	-93.8
LTE-FDD B66 (10 MHz)	TBD	TBD	TBD	-95.8
LTE-FDD B71 (10 MHz)	TBD	TBD	TBD	-93.5
LTE-TDD B41 (10 MHz)	TBD	TBD	TBD	-94.3

7.8. ESD Protection

Static electricity occurs naturally and it may damage the module. Therefore, applying proper ESD countermeasures and handling methods is imperative. For example, wear anti-static gloves during the development, production, assembly and testing of the module; add ESD protection components to the ESD sensitive interfaces and points in the product design.

The following table shows the electrostatic discharge characteristics of the module.

Table 59: Electrostatic Discharge Characteristics (Temperature: 25 °C, Humidity: 45 %)

Tested Interfaces	Contact Discharge	Air Discharge	Unit
VBAT, GND	±5	±10	kV
Antenna Interfaces	±5	±10	kV
Other Interfaces	±0.5	±1	kV

8 Mechanical Information

This chapter describes the mechanical dimensions of the module. All dimensions are measured in millimeter (mm), and the dimensional tolerances are ± 0.2 mm unless otherwise specified.

8.1. Mechanical Dimensions

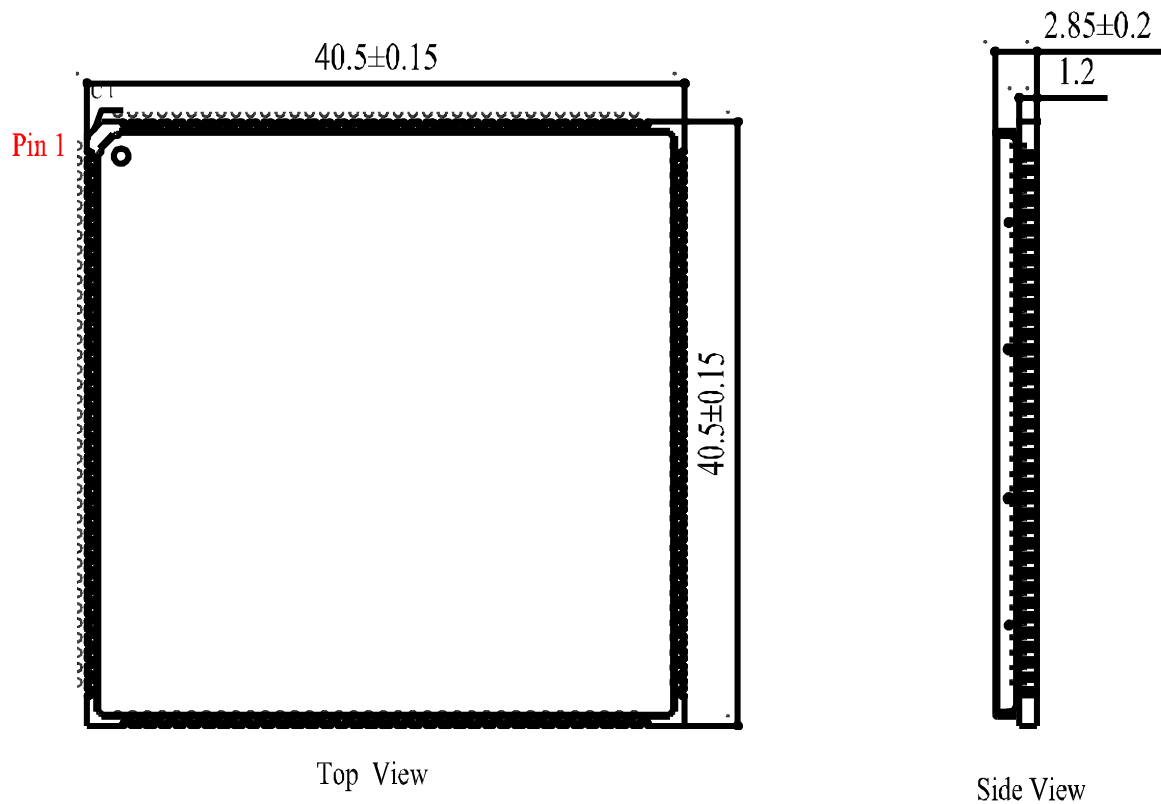

Figure 40: Module Top and Side Dimensions

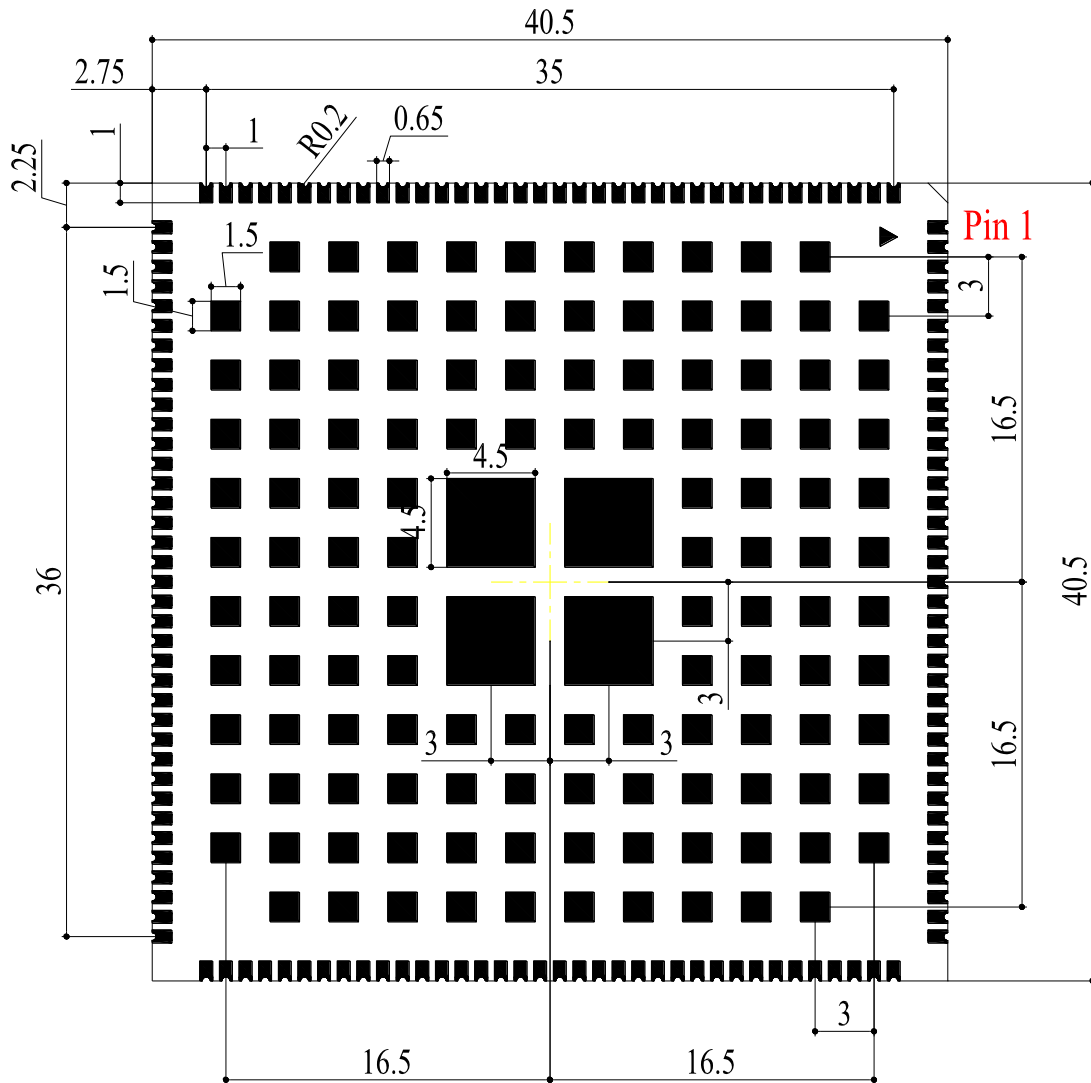

Figure 41: Module Bottom Dimensions (Bottom View)

NOTE

The package warpage level of the module conforms to JEITA ED-7306 standard.

8.2. Recommended Footprint

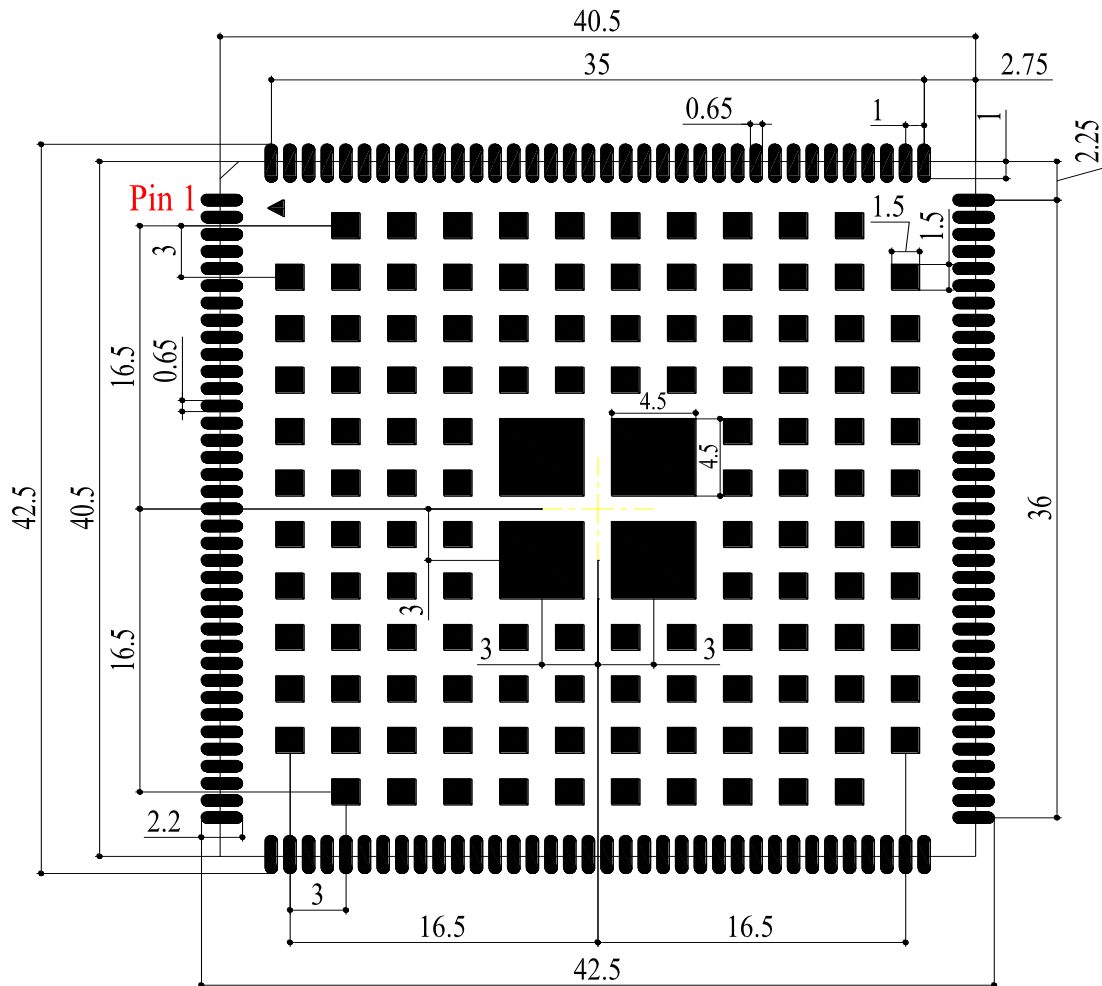

Figure 42: Recommended Footprint (Top View)

NOTE

Keep at least 3 mm between the module and other components on the motherboard to improve soldering quality and maintenance convenience.

8.3. Top and Bottom Views

Figure 43: Top and Bottom Views of the Module

NOTE

Images above are for illustration purpose only and may differ from the actual module. For authentic appearance and label, please refer to the module received from Quectel.

9 Storage, Manufacturing & Packaging

9.1. Storage Conditions

The module is provided with vacuum-sealed packaging. MSL of the module is rated as 3. The storage requirements are shown below.

1. Recommended Storage Condition: the temperature should be 23 ± 5 °C and the relative humidity should be 35–60 %.
2. Shelf life (in a vacuum-sealed packaging): 12 months in Recommended Storage Condition.
3. Floor life: 168 hours⁷ in a factory where the temperature is 23 ± 5 °C and relative humidity is below 60 %. After the vacuum-sealed packaging is removed, the module must be processed in reflow soldering or other high-temperature operations within 168 hours. Otherwise, the module should be stored in an environment where the relative humidity is less than 10 % (e.g., a dry cabinet).
4. The module should be pre-baked to avoid blistering, cracks and inner-layer separation in PCB under the following circumstances:
 - The module is not stored in Recommended Storage Condition;
 - Violation of the third requirement mentioned above;
 - Vacuum-sealed packaging is broken, or the packaging has been removed for over 24 hours;
 - Before module repairing.
5. If needed, the pre-baking should follow the requirements below:
 - The module should be baked for 8 hours at 120 ± 5 °C;
 - The module must be soldered to PCB within 24 hours after the baking, otherwise it should be put in a dry environment such as in a dry cabinet.

⁷ This floor life is only applicable when the environment conforms to *IPC/JEDEC J-STD-033*. It is recommended to start the solder reflow process within 24 hours after the package is removed if the temperature and moisture do not conform to, or are not sure to conform to *IPC/JEDEC J-STD-033*. And do not remove the packages of tremendous modules if they are not ready for soldering.

NOTE

1. To avoid blistering, layer separation and other soldering issues, extended exposure of the module to the air is forbidden.
2. Take out the module from the package and put it on high-temperature-resistant fixtures before baking. All modules must be soldered to PCB within 24 hours after the baking, otherwise put them in the drying oven. If shorter baking time is desired, see *IPC/JEDEC J-STD-033* for the baking procedure.
3. Pay attention to ESD protection, such as wearing anti-static gloves, when touching the modules.

9.2. Manufacturing and Soldering

Push the squeegee to apply the solder paste on the surface of stencil, thus making the paste fill the stencil openings and then penetrate to the PCB. Apply proper force on the squeegee to produce a clean stencil surface on a single pass. To guarantee module soldering quality, the thickness of stencil for the module is recommended to be 0.18–0.20 mm. For more details, see **document [4]**.

The peak reflow temperature should be 235–246 °C, with 246 °C as the absolute maximum reflow temperature. To avoid damage to the module caused by repeated heating, it is strongly recommended that the module should be mounted only after reflow soldering for the other side of PCB has been completed. The recommended reflow soldering thermal profile (lead-free reflow soldering) and related parameters are shown below.

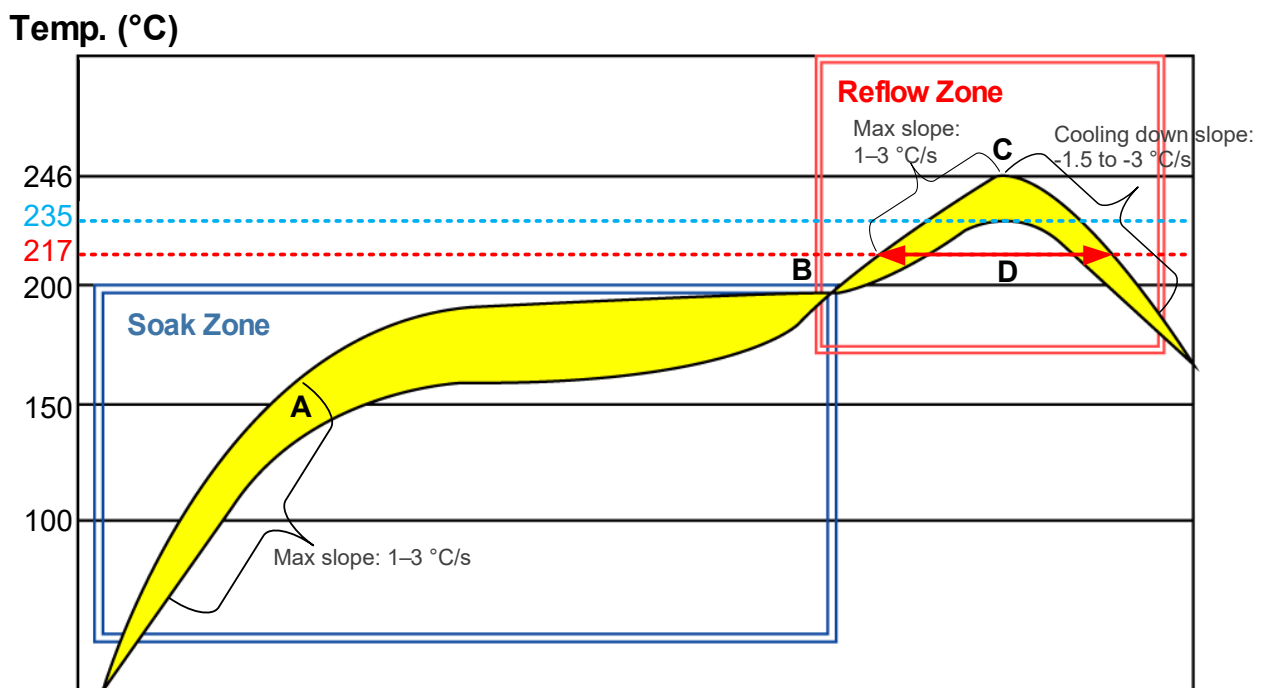

Figure 44: Recommended Reflow Soldering Thermal Profile

Table 60: Recommended Thermal Profile Parameters

Factor	Recommendation
Soak Zone	
Max slope	1–3 °C/s
Soak time (between A and B: 150 °C and 200 °C)	70–120 s
Reflow Zone	
Max slope	1–3 °C/s
Reflow time (D: over 217 °C)	40–70 s
Max temperature	235 °C to 246 °C
Cooling down slope	-1.5 to -3 °C/s
Reflow Cycle	
Max reflow cycle	1

NOTE

1. If a conformal coating is necessary for the module, do NOT use any coating material that may chemically react with the PCB or shielding cover, and prevent the coating material from flowing into the module.
2. Avoid using ultrasonic technology for module cleaning since it can damage crystals inside the module.
3. Due to the complexity of the SMT process, please contact Quectel Technical Supports in advance for any situation that you are not sure about, or any process (e.g., selective soldering, ultrasonic soldering) that is not mentioned in **document [4]**.

9.3. Packaging Specification

Dimension details are as follow:

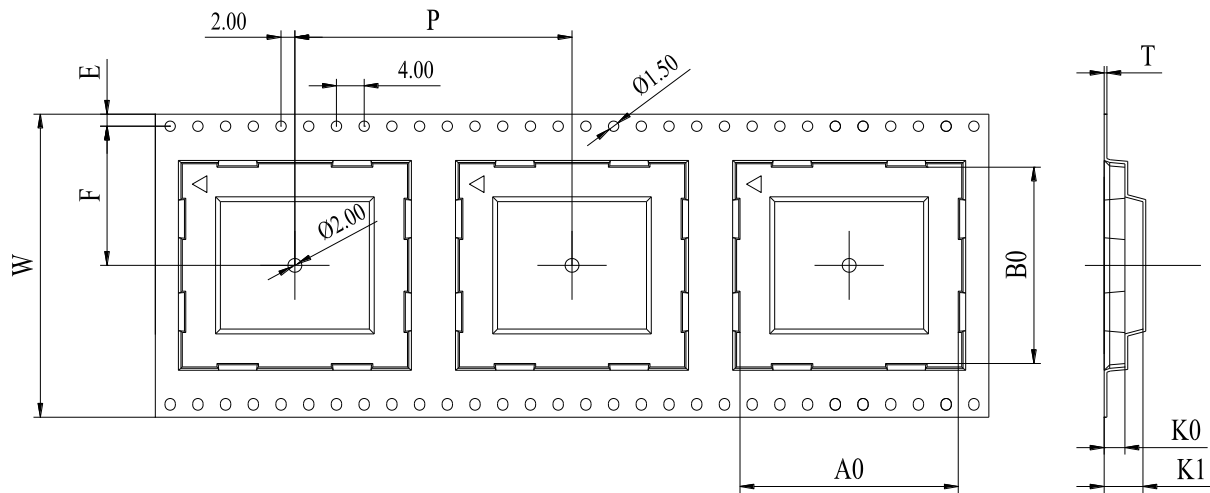

Figure 45: Carrier Tape Dimension Drawing

Table 61: Recommended Thermal Profile Parameters

W	P	T	A0	B0	K0	K1	F	E
72	56	0.4	41.2	41.2	4	4.6	34.2	1.75

9.3.1. Plastic Reel

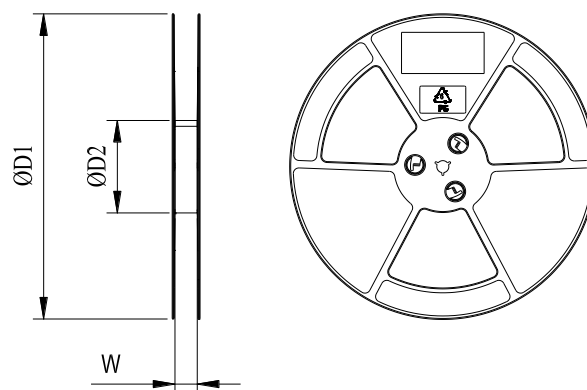
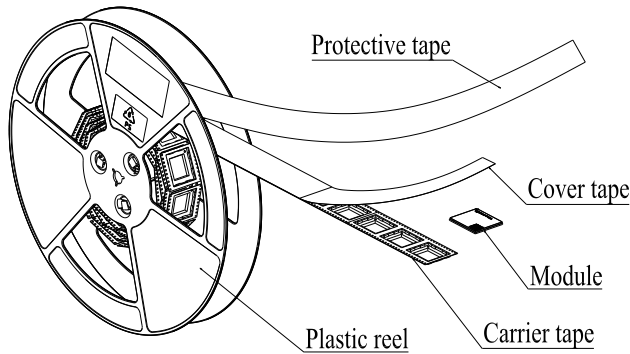

Figure 46: Plastic Reel Dimension Drawing

Table 62: Plastic Reel Dimension Table (Unit: mm)

$\phi D1$	$\phi D2$	W
380	180	72.5

9.3.2. Packaging Process



Place the module into the carrier tape and use the cover tape to cover them; then wind the heat-sealed carrier tape to the plastic reel and use the protective tape for protection. One plastic reel can load 200 modules.

Place the packaged plastic reel, humidity indicator card and desiccant bag into a vacuum bag, then vacuumize it.

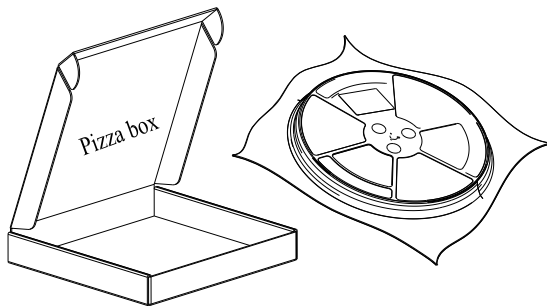
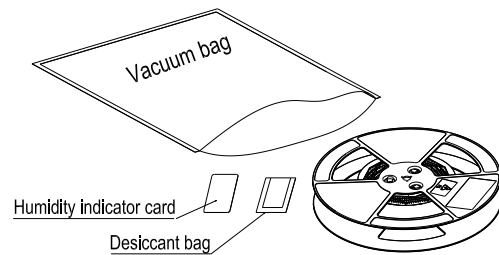

Place the vacuum-packed plastic reel into a pizza box.

Put 4 pizza boxes into 1 carton and seal it. One carton can load 800 modules.

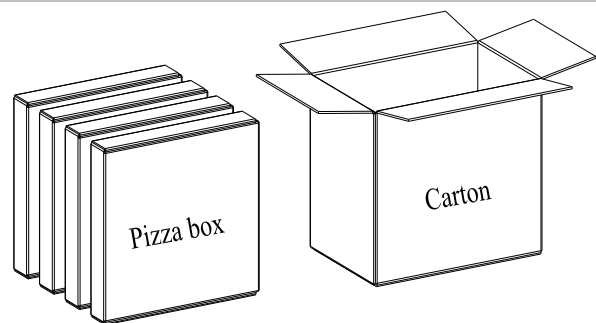

Figure 47: Packaging Process

10 Appendix References

Table 63: Related Documents

Document Name
[1] Quectel_Smart_EVB_G2_User_Guide
[2] Quectel_SC206E_Series_GPIO_Configuration
[3] Quectel_RF_Layout_Application_Note
[4] Quectel_Module_Secondary_SMT_Application_Note

Table 64: Terms and Abbreviations

Abbreviation	Description
3GPP	3rd Generation Partnership Project
ADC	Analog-to-Digital Converter
ADSP	Audio Digital Signal Processor
ALS	Ambient Light Sensor
AMR-NB	Adaptive Multi Rate-Narrow Band Speech Codec
AMR-WB	Adaptive Multi-Rate Wideband
AP	Access Point/Application Processor
ARM	Advanced RISC Machine
BDS	BeiDou Navigation Satellite System
BLE	Bluetooth Low Energy
bps	Bits per Second
BR	Basic Rate

CDMA	Code Division Multiple Access
CEP	Circular Error Probable
CPE	Customer-Premise Equipment
CS	Coding Scheme
CSD	Circuit Switched Data
CSI	Camera Serial Interface
CTS	Clear to Send
DC	Dual Carrier
DC-HSPA+	Dual Carrier High Speed Packet Access Plus
DCE	Data Communications Equipment/Data Circuit terminating Equipment
DCS	Digital Cellular System
DL	Downlink
DPSK	Differential Phase Shift Keying
DQPSK	Differential Quadrature Reference Phase Shift Keying
DRX	Discontinuous Reception
DSI	Display Serial Interface
DSP	Digital Signal Processor
DTE	Data Terminal Equipment
ECM	Electret Condenser Microphone
EDGE	Enhanced Data Rate for GSM Evolution
EDR	Enhanced Data Rate
EFR	Enhanced Full Rate
EGSM	Extended GSM
eMMC	Embedded Multimedia Card
eSCO	Extended Synchronous Connection Oriented

ESD	Electrostatic Discharge
ESR	Equivalent Series Resistance
ETSI	European Telecommunications Standards Institute
EVB	Evaluation Board
EV-DO	Evolution-Data Optimized
EVRC	Enhanced Variable Rate Codec
FDD	Frequency Division Duplex
fps	Frame per Second
FR	Full Rate
Galileo	Galileo Satellite Navigation System (EU)
GFSK	Gaussian Frequency Shift Keying
GLONASS	Global Navigation Satellite System (Russia)
GMSK	Gaussian Minimum Shift Keying
GND	Ground
GNSS	Global Navigation Satellite System
GPIO	General Purpose Input/Output
GPRS	General Packet Radio Service
GPS	Global Positioning System
GPU	Graphics Processing Unit
GRFC	Generic RF control
GSM	Global System for Mobile Communications
G.W.	Gross Weight
HR	Half Rate
HS	High Speed
HSDPA	High Speed Downlink Packet Access

HSPA+	High-Speed Packet Access+
HSUPA	High Speed Uplink Packet Access
HT	High Throughput
I2C	Inter-Integrated Circuit
IC	Integrated Circuit
IEEE	Institute of Electrical and Electronics Engineers
IMT-2000	International Mobile Telecommunications for the year 2000
I/O	Input/Output
$I_{I\max}$	Maximum Input Load Current
$I_{O\max}$	Maximum Output Load Current
ISP	Image Signal Processor/Internet Service Provider
LCC	Leadless Chip Carrier
LCD	Liquid Crystal Display
LCM	LCD Module
LDO	Low Dropout Regulator
LE	Low Energy
LED	Light Emitting Diode
LGA	Land Grid Array
LNA	Low Noise Amplifier
LPDDR	Low-Power Double Data Rate
LTE	Long-Term Evolution
M2M	Machine to Machine
MAC	Media Access Control
MCS	Modulation and Coding Scheme
MEMS	Micro-Electro-Mechanical System

MIC	Microphone
MIMO	Multi-Input Multi-Output / Multiple Input Multiple Output
MIPI	Mobile Industry Processor Interface
MP	Megapixel
MO	Mobile Originating/Originated
MOQ	Minimum Order Quantity
MSL	Moisture Sensitivity Levels
MT	Mobile Terminating/Terminated
NavIC	Indian Regional Navigation Satellite System
N.W.	Net Weight
NFC	Near Field Communication
NTC	Negative Temperature Coefficient
OTA	Over-the-Air Upgrade
OTG	On-The-Go
OTP	One Time Programable
PA	Power Amplifier
PC	Personal Computer
PCB	Printed Circuit Board
PCL	Power Control Level
PCS	Personal Communication Service
PDA	Personal Digital Assistant
PDU	Protocol Data Unit
PHY	Physical Layer
PMU	Power Management Unit
POS	Point of Sale

PWM	Pulse Width Modulation
PSK	Phase Shift Keying
QAM	Quadrature Amplitude Modulation
QPSK	Quadrature Phase Shift Keying
QZSS	Quasi-Zenith Satellite System
RF	Radio Frequency
RHCP	Right Hand Circular Polarization
RoHS	Restriction of Hazardous Substances
RTC	Real Time Clock
RTS	Request to Send
SBAS	Satellite-Based Augmentation System
SCO	Synchronous Connection Oriented
SD	Secure Digital
SIMO	Single Input Multiple Output
SMD	Surface Mounting Device
SMS	Short Message Service
SMT	Surface Mount Technology
STA	Station
TDD	Time-Division Duplex
TP	Touch Panel
TTF	Time to First Fix
TVS	Transient Voltage Suppressor
UART	Universal Asynchronous Receiver & Transmitter
UL	Uplink
UMTS	Universal Mobile Telecommunications System

USB	Universal Serial Bus
(U)SIM	(Universal) Subscriber Identity Module
VBAT	Voltage at Battery (Pin)
VHT	Very High Throughput
Vmax	Maximum Voltage
Vmin	Minimum Voltage
Vnom	Nominal Voltage
V _I max	Absolute Maximum Input Voltage
V _I min	Absolute Minimum Input Voltage
V _{IH} min	Minimum High-level Input Voltage
V _{IL} max	Maximum Low-level Input Voltage
V _O max	Maximum Output Voltage
V _{OH} min	Minimum High-level Output Voltage
V _{OL} max	Maximum Low-level Output Voltage
Vrms	Root Mean Square Voltage
VSWR	Voltage Standing Wave Ratio
WAPI	WLAN Authentication and Privacy Infrastructure
WCDMA	Wideband Code Division Multiple Access
Wi-Fi	Wireless Fidelity
WLAN	Wireless Local Area Network
