

EM060K Series&EM120K-GL

Hardware Design

LTE-A Module Series

Version: 0.1

Date: 2023-06-12

Status: Draft



At Quectel, our aim is to provide timely and comprehensive services to our customers. If you require any assistance, please contact our headquarters:

Quectel Wireless Solutions Co., Ltd.

Building 5, Shanghai Business Park Phase III (Area B), No.1016 Tianlin Road, Minhang District, Shanghai 200233, China

Tel: +86 21 5108 6236

Email: info@quectel.com

Or our local offices. For more information, please visit:

<http://www.quectel.com/support/sales.htm>.

For technical support, or to report documentation errors, please visit:

<http://www.quectel.com/support/technical.htm>.

Or email us at: support@quectel.com.

Legal Notices

We offer information as a service to you. The provided information is based on your requirements and we make every effort to ensure its quality. You agree that you are responsible for using independent analysis and evaluation in designing intended products, and we provide reference designs for illustrative purposes only. Before using any hardware, software or service guided by this document, please read this notice carefully. Even though we employ commercially reasonable efforts to provide the best possible experience, you hereby acknowledge and agree that this document and related services hereunder are provided to you on an “as available” basis. We may revise or restate this document from time to time at our sole discretion without any prior notice to you.

Use and Disclosure Restrictions

License Agreements

Documents and information provided by us shall be kept confidential, unless specific permission is granted. They shall not be accessed or used for any purpose except as expressly provided herein.

Copyright

Our and third-party products hereunder may contain copyrighted material. Such copyrighted material shall not be copied, reproduced, distributed, merged, published, translated, or modified without prior written consent. We and the third party have exclusive rights over copyrighted material. No license shall be granted or conveyed under any patents, copyrights, trademarks, or service mark rights. To avoid ambiguities, purchasing in any form cannot be deemed as granting a license other than the normal non-exclusive, royalty-free license to use the material. We reserve the right to take legal action for noncompliance with abovementioned requirements, unauthorized use, or other illegal or malicious use of the material.

Trademarks

Except as otherwise set forth herein, nothing in this document shall be construed as conferring any rights to use any trademark, trade name or name, abbreviation, or counterfeit product thereof owned by Quectel or any third party in advertising, publicity, or other aspects.

Third-Party Rights

This document may refer to hardware, software and/or documentation owned by one or more third parties (“third-party materials”). Use of such third-party materials shall be governed by all restrictions and obligations applicable thereto.

We make no warranty or representation, either express or implied, regarding the third-party materials, including but not limited to any implied or statutory, warranties of merchantability or fitness for a particular purpose, quiet enjoyment, system integration, information accuracy, and non-infringement of any third-party intellectual property rights with regard to the licensed technology or use thereof. Nothing herein constitutes a representation or warranty by us to either develop, enhance, modify, distribute, market, sell, offer for sale, or otherwise maintain production of any our products or any other hardware, software, device, tool, information, or product. We moreover disclaim any and all warranties arising from the course of dealing or usage of trade.

Privacy Policy

To implement module functionality, certain device data are uploaded to Quectel’s or third-party’s servers, including carriers, chipset suppliers or customer-designated servers. Quectel, strictly abiding by the relevant laws and regulations, shall retain, use, disclose or otherwise process relevant data for the purpose of performing the service only or as permitted by applicable laws. Before data interaction with third parties, please be informed of their privacy and data security policy.

Disclaimer

- a) We acknowledge no liability for any injury or damage arising from the reliance upon the information.
- b) We shall bear no liability resulting from any inaccuracies or omissions, or from the use of the information contained herein.
- c) While we have made every effort to ensure that the functions and features under development are free from errors, it is possible that they could contain errors, inaccuracies, and omissions. Unless otherwise provided by valid agreement, we make no warranties of any kind, either implied or express, and exclude all liability for any loss or damage suffered in connection with the use of features and functions under development, to the maximum extent permitted by law, regardless of whether such loss or damage may have been foreseeable.
- d) We are not responsible for the accessibility, safety, accuracy, availability, legality, or completeness of information, advertising, commercial offers, products, services, and materials on third-party websites and third-party resources.

Copyright © Quectel Wireless Solutions Co., Ltd. 2023. All rights reserved.

Safety Information

The following safety precautions must be observed during all phases of operation, such as usage, service or repair of any terminal or mobile incorporating the module. Manufacturers of the cellular terminal should notify users and operating personnel of the following safety information by incorporating these guidelines into all manuals of the product. Otherwise, Quectel assumes no liability for customers' failure to comply with these precautions.



Full attention must be paid to driving at all times in order to reduce the risk of an accident. Using a mobile while driving (even with a handsfree kit) causes distraction and can lead to an accident. Please comply with laws and regulations restricting the use of wireless devices while driving.



Switch off the cellular terminal or mobile before boarding an aircraft. The operation of wireless appliances in an aircraft is forbidden to prevent interference with communication systems. If there is an Airplane Mode, it should be enabled prior to boarding an aircraft. Please consult the airline staff for more restrictions on the use of wireless devices on an aircraft.



Wireless devices may cause interference on sensitive medical equipment, so please be aware of the restrictions on the use of wireless devices when in hospitals, clinics or other healthcare facilities.



Cellular terminals or mobiles operating over radio signal and cellular network cannot be guaranteed to connect in certain conditions, such as when the mobile bill is unpaid or the (U)SIM card is invalid. When emergency help is needed in such conditions, use emergency call if the device supports it. In order to make or receive a call, the cellular terminal or mobile must be switched on in a service area with adequate cellular signal strength. In an emergency, the device with emergency call function cannot be used as the only contact method considering network connection cannot be guaranteed under all circumstances.



The cellular terminal or mobile contains a transceiver. When it is ON, it receives and transmits radio frequency signals. RF interference can occur if it is used close to TV sets, radios, computers or other electric equipment.



In locations with explosive or potentially explosive atmospheres, obey all posted signs and turn off wireless devices such as mobile phone or other cellular terminals. Areas with explosive or potentially explosive atmospheres include fuelling areas, below decks on boats, fuel or chemical transfer or storage facilities, and areas where the air contains chemicals or particles such as grain, dust or metal powders.

About the Document

Revision History

Version	Date	Author	Description
-	2023-06-12	Frank GAO / Henry YANGf	Creation of the document
0.1	2023-06-12	Frank GAO / Henry YANG	Draft (Refer to Hardware Design V1.1.0)

Contents

Safety Information..... 3

About the Document..... 4

Contents..... 5

Table Index..... 8

Figure Index..... 10

1 Introduction 12

 1.1. Reference Standards 12

 1.2. Special Marks..... 13

2 Product Overview 14

 2.1. Frequency Bands and Functions 14

 2.2. Key Features..... 15

 2.3. Functional Diagram 18

 2.4. Pin Assignment 20

 2.5. Pin Description 21

 2.6. EVB Kit..... 25

3 Operating Characteristics 26

 3.1. Operating Modes..... 26

 3.2. Sleep Mode 27

 3.3. Airplane Mode 28

 3.4. Communication Interface with Host 28

 3.5. Power Supply 28

 3.5.1. Power Supply Pins 28

 3.5.2. Reference Design for Power Supply..... 28

 3.5.3. Voltage Stability Requirements..... 29

 3.5.4. Monitor the Power Supply 30

 3.6. Turn-on..... 30

 3.7. Turn-off..... 32

 3.8. Reset..... 33

4 Application Interfaces 35

 4.1. (U)SIM Interface..... 35

 4.1.1. Pin definition of (U)SIM 35

 4.1.2. (U)SIM Hot-swap..... 36

 4.1.3. Normally Closed (U)SIM Card Connector..... 37

 4.1.4. Normally Open (U)SIM Card Connector 38

 4.1.5. (U)SIM Card Connector Without Hot-swap..... 38

 4.1.6. (U)SIM2 Card Compatible Design 39

 4.1.7. (U)SIM Design Notices..... 40

4.2.	USB Interface.....	40
4.3.	PCM Interface*.....	42
4.4.	Control and Indication Interfaces.....	43
4.4.1.	W_DISABLE1#.....	44
4.4.2.	W_DISABLE2#.....	44
4.4.3.	WWAN_LED#.....	46
4.4.4.	WAKE_ON_WAN#.....	46
4.4.5.	DPR.....	47
4.4.6.	WLAN_PA_EN.....	48
4.5.	Cellular/WLAN COEX Interface*.....	48
4.6.	Configuration Pins.....	49
4.7.	PCIe Interface.....	50
4.7.1.	Root Complex Mode.....	51
5	Antenna Interfaces.....	53
5.1.	Cellular Network.....	53
5.1.1.	Antenna Interfaces & Frequency Bands.....	53
5.1.2.	Antenna Tuner Control Interface*.....	57
5.1.2.1.	Antenna Tuner Control Interface through GPIOs.....	57
5.1.2.2.	Antenna Tuner Control Interface through RFFE.....	58
5.1.3.	Tx Power.....	58
5.1.4.	Rx Sensitivity.....	59
5.2.	GNSS.....	64
5.2.1.	Antenna Interface & Frequency Bands.....	64
5.2.2.	GNSS Performance.....	64
5.3.	Antenna Design Requirements.....	65
5.4.	Antenna Connectors.....	67
5.4.1.	Antenna Connector Location.....	67
5.4.2.	Antenna Connector Specifications.....	68
5.4.3.	Antenna Connector Installation.....	69
6	Electrical Characteristics and Reliability.....	72
6.1.	Absolute Maximum Ratings.....	72
6.2.	Power Supply Ratings.....	72
6.3.	Power Consumption.....	73
6.4.	Digital I/O Characteristics.....	82
6.5.	ESD Protection.....	83
6.6.	Operating and Storage Temperatures.....	84
6.7.	Thermal Dissipation.....	85
6.8.	Notification.....	86
6.8.1.	Coating.....	87
6.8.2.	Cleaning.....	87
6.8.3.	Installing.....	87
7	Mechanical Information and Packaging.....	88
7.1.	Mechanical Dimensions.....	88

7.2.	Top and Bottom Views	89
7.3.	M.2 Connector.....	91
7.4.	Module Installation	91
7.5.	Packaging Specification.....	92
7.5.1.	Blister Tray	92
7.5.2.	Packaging Process	94
8	Appendix References	95

Table Index

Table 1: Special Marks.....	13
Table 2: Frequency Bands and GNSS Functions of EM060K Series and EM120K-GL	14
Table 3: Key Features.....	15
Table 4: Definition of I/O Parameters.....	21
Table 5: Pin Description	21
Table 6: Overview of Operating Modes	26
Table 7: Definition of VCC and GND Pins	28
Table 8: Pin Definition of FULL_CARD_POWER_OFF#.....	30
Table 9: Turn-on Timing of the Module.....	32
Table 10: Turn-off Timing of the Module.....	32
Table 11: Pin Definition of RESET#	33
Table 12: Reset Timing of the Module	34
Table 13: Pin Definition of (U)SIM Interfaces	35
Table 14: Pin Definition of USB Interface	40
Table 15: Pin Definition of PCM Interface.....	43
Table 16: Pin Definition of Control and Indication Interfaces.....	43
Table 17: RF Function Status	44
Table 18: GNSS Function Status.....	45
Table 19: Network Status Indications of WWAN_LED#	46
Table 20: State of the WAKE_ON_WAN#	46
Table 21: Pin definition of DPR.....	47
Table 22: Function of the DPR Signal.....	47
Table 23: Pin definition of WLAN_PA_EN	48
Table 24: Pin Definition of Cellular/WLAN COEX Interface.....	49
Table 25: List of Configuration Pins	49
Table 26: Pin Definition of Configuration Pins	49
Table 27: Pin Definition of the PCIe Interface.....	50
Table 28: PCIe Trace Length Inside the Module	52
Table 29: Antenna Connectors Definition for EM060K-GL & EM120K-GL	53
Table 30: Antenna Connectors Definition for EM060K-NA.....	53
Table 31: Antenna Connectors Definition for EM060K-EA.....	54
Table 32: Frequency Bands for EM060K-GL & EM120K-GL	54
Table 33: Frequency Bands for EM060K-NA	56
Table 34: Frequency Bands for EM060K-EA.....	57
Table 35: Pin Definition of Antenna Tuner Control Interface through GPIOs.....	57
Table 36: Pin Definition of Antenna Tuner Control Interface through RFFE	58
Table 37: EM060K-GL , EM120K-GL and EM060K-EA Tx Power.....	58
Table 38: EM060K-NA Tx Power	58
Table 39: EM060K-GL Rx Sensitivity.....	59
Table 40: EM120K-GL Rx Sensitivity.....	61
Table 41: EM060K-NA Rx Sensitivity	62

Table 42: EM060K-EA Rx Sensitivity.....	63
Table 43: GNSS Frequency	64
Table 44: GNSS Performance	64
Table 45: Antenna Requirements	65
Table 46: Major Specifications of the RF Connectors	69
Table 47: Absolute Maximum Ratings	72
Table 48: Power Supply Requirements	72
Table 49: EM060K-GL Power Consumption (3.7 V Power Supply)	73
Table 50: EM060K-NA Power Consumption (3.7 V Power Supply)	76
Table 51: EM120K-GL Power Consumption (3.7 V Power Supply)	77
Table 52: EM060K-EA Power Consumption (3.7 V Power Supply)	80
Table 53: (U)SIM 1.8 V I/O Requirements.....	82
Table 54: (U)SIM 3.0 V I/O Requirements	82
Table 55: 1.8 V Digital I/O Requirements	83
Table 56: 3.3 V Digital I/O Requirements	83
Table 57: Electrostatic Discharge Characteristics (Temperature: 25–30 °C, Humidity: 40 ±5 %)	83
Table 58: Operating and Storage Temperatures	84
Table 59: Maximum Operating Temperature for Main Chips (Unit: °C)	86
Table 60: Related Documents.....	95
Table 61: Terms and Abbreviations	95

Figure Index

Figure 1: Functional Diagram for EM060K-GL&EM120K-GL..... 18

Figure 2: Functional Diagram for EM060K-NA and EM060K-EA 19

Figure 3: Pin Assignment 20

Figure 4: DRX Run Time and Current Consumption in Sleep Mode..... 27

Figure 5: Sleep Mode Application with USB Remote Wakeup Function 27

Figure 6: Reference Circuit for Power Supply 29

Figure 7: Power Supply Limits During Burst Transmission 29

Figure 8: Reference Circuit for VCC Pins 30

Figure 9: Turn On the Module with a Host GPIO..... 31

Figure 10: Turn-on Timing..... 31

Figure 11: Turn-off Timing..... 32

Figure 12: Reference Circuit of RESET# with Open Collector Driving Circuit 33

Figure 13: Reset Timing..... 34

Figure 14: Reference Circuit for Normally Closed (U)SIM Card Connector 37

Figure 15: Reference Circuit for Normally Open (U)SIM Card Connector 38

Figure 16: Reference Circuit for 6-Pin (U)SIM Card Connector 39

Figure 17: Recommended Compatible Design for (U)SIM2 Interface..... 39

Figure 18: Reference Circuit for USB Interface 41

Figure 19: Primary Mode Timing..... 42

Figure 20: Auxiliary Mode Timing 43

Figure 21: Reference Circuit of W_DISABLE1# and W_DISABLE2# 45

Figure 22: WWAN_LED# Reference Circuit 46

Figure 23: Reference Circuit of WAKE_ON_WAN# 47

Figure 24: Reference Design of DPR 48

Figure 25: Recommended Circuit of Configuration Pins..... 50

Figure 26: Reference Circuit of PCIe Interface (RC Mode)..... 51

Figure 27: Antenna Connectors on EM060K-GL & EM120K-GL 67

Figure 28: Antenna Connectors on EM060K-NA 67

Figure 29: Antenna Connectors on EM060K-EA 68

Figure 30: Dimensions of the Receptacle (Unit: mm)..... 69

Figure 31: Dimensions of Mated Plugs (Ø0.81/Ø1.13 mm Coaxial Cables) (Unit: mm) 70

Figure 32: Space Factor of Mated Connectors (Ø0.81 mm Coaxial Cables) (Unit: mm)..... 70

Figure 33: Space Factor of Mated Connectors (Ø 1.13 mm Coaxial Cables) (Unit: mm) 71

Figure 34: Distribution of Heat Source Chips Inside the EM060K-GL&EM120K-GL..... 85

Figure 35: Distribution of Heat Source Chips Inside the EM060K-NA 85

Figure 36: Placement and Fixing of the Heatsink..... 86

Figure 37: EM060K-GL&EM120K-GL Mechanical Dimensions 88

Figure 38: EM060K-NA Mechanical Dimensions..... 89

Figure 39: EM060K-GL Top and Bottom Views..... 89

Figure 40: EM120K-GL Top and Bottom Views..... 90

Figure 41: EM060K-NA Top and Bottom Views 90

Figure 42: EM060K-EA Top and Bottom Views	91
Figure 43: Installation Schematic	92
Figure 44: Blister Tray Dimension Drawing	93
Figure 45: Packaging Process	94

1 Introduction

This document defines EM060K series and EM120K-GL module and defines their air interfaces and hardware interfaces which are connected with your application

With this document, you can quickly understand module interface specifications, electrical and mechanical details, as well as other related information of the module. The document, coupled with application notes and user guides, makes it easy to design and set up mobile applications with the module.

1.1. Reference Standards

The module complies with the following standards:

- *PCI Express M.2 Specification Revision 4.0, Version 1.1*
- *PCI Express Base Specification Revision 4.0*
- *Universal Serial Bus 3.1 Specification*
- *ISO/IEC 7816-3*
- *MIPI Alliance Specification for RF Front-End Control Interface Version 2.0*
- *3GPP TS 27.007 and 3GPP 27.005*
- *3GPP TS 34.121-1 and 3GPP TS 36.521-1*

Hereby, Quectel Wireless Solutions Co., Ltd. declares that the radio equipment type EM060K-EA, EM060K-GL, EM120K-GL are in compliance with Directive 2014/53/EU.

The full text of the EU declaration of conformity is available at the following internet address:
<http://www.quectel.com/support/technical.htm>

The device could be used with a separation distance of 20cm to the human body.

Disposal of old electrical appliances



The European directive 2012/19/EU on Waste Electrical and Electronic Equipment (WEEE), requires that old household electrical appliances must not be disposed of in the normal unsorted municipal waste stream. Old appliances must be collected separately in order to optimize the recovery and recycling of the materials they contain, and reduce the impact on human health and the environment.

The crossed out "wheeled bin" symbol on the product reminds you of your obligation, that when you dispose of the appliance, it must be separately collected.

Consumers should contact their local authority or retailer for information concerning the correct disposal of their old appliance.

1.2. Special Marks

Table 1: Special Marks

Mark	Definition
*	Unless otherwise specified, when an asterisk (*) is used after a function, feature, interface, pin name, AT command, or argument, it indicates that the function, feature, interface, pin, AT command, or argument is under development and currently not supported; and the asterisk (*) after a model indicates that the sample of the model is currently unavailable.
[...]	Brackets ([...]) used after a pin enclosing a range of numbers indicate all pins of the same type. For example, SDIO_DATA [0:3] refers to all four SDIO pins: SDIO_DATA0, SDIO_DATA1, SDIO_DATA2, and SDIO_DATA3.

2 Product Overview

2.1. Frequency Bands and Functions

EM060K series (include EM060K-GL, EM060K-NA and EM060K-EA) and EM120K-GL are LTE-A/UMTS/HSPA+ wireless communication modules with receiving diversity. They provide data connectivity on LTE-FDD, LTE-TDD, DC-HSDPA, HSPA+, HSDPA, HSUPA and WCDMA networks. They are standard M.2 Key-B WWAN modules. For more details, see *PCI Express M.2 Specification Revision 4.0, Version 1.1*.

They support embedded operating systems such as Windows, Linux and Android, and also provide GNSS and voice functionality ¹ to meet specific application demands.

The following table shows the frequency bands and GNSS functions of the module. For details about CA combinations, you can see **document [1]**.

Table 2: Frequency Bands and GNSS Functions of EM060K Series and EM120K-GL

Mode	EM060K-GL	EM060K-NA	EM060K-EA	EM120K-GL
LTE-FDD (with Rx-diversity)	B1/B2/B3/B4/B5/B7/B8 /B12/B13/B14/B17 ² /B18/B19/B20/B25/B26/B28/B29 ³ /B30/B32 ³ /B66/B71	B2/B4/B5/B7/B12/ B13/B14/B17 ² /B25/B26/B29 ³ /B30/B66/B71	B1/B3/B5/B7/B8/B20/B28/B32 ³	B1/B2/B3/B4/B5/B7/B8/B12/B13/B14/B17 ² /B18/B19/B20/B25/B26/B28/B29 ³ /B30/B32 ³ /B66/B71
LTE-TDD (with Rx-diversity)	B34/B38/B39/B40/B41 /B42/B43/B46 ³ (LAA)/B48(CBRS)	B41/B42/B43/B48	B38/B40/B41	B34/B38/B39/B40/B41/B42/B43/B46 ³ (LAA)/B48(CBRS)
WCDMA (with Rx-diversity)	B1/B2/B3/B4/B5/B6/B8 /B19		B1/B3/B5/B8	B1/B2/B3/B4/B5/B6/B8/B19

1 The module contains **Data + Voice*** and **Data-only** version. **Data + Voice*** version supports voice and data functions, while **Data-only** version only supports data function.

2 B17 is supported through MFBI + B12.

3 LTE-FDD B29/B32 and LTE-TDD B46 support Rx only and are only for secondary component carrier.

GNSS	GPS/GLONASS/BDS/ Galileo	GPS/GLONASS/ BDS/ Galileo	GPS/GLONAS S/BDS/ Galileo	GPS/GLONASS/BDS/Gali leo
------	-----------------------------	------------------------------	------------------------------	-----------------------------

The module can be applied to a wide range of applications such as industrial routers, home gateways, set-top boxes, industrial laptops, consumer laptops, industrial PDAs, rugged tablet PCs and digital signage, etc.

2.2. Key Features

Table 3: Key Features

Feature	Details
Function Interface	PCI Express M.2 Interface
Power Supply	<ul style="list-style-type: none"> ● Supply voltage: 3.135–4.4 V ● Typical supply voltage: 3.7 V
(U)SIM Interface	<ul style="list-style-type: none"> ● Compliant with <i>ISO/IEC 7816-3</i> and ETSI and IMT-2000 requirements ● Supports (U)SIM card: 1.8/3.0 V ● Supports Dual SIM Single Standby
eSIM (Optional)	Supports built-in eSIM function
USB Interface	<ul style="list-style-type: none"> ● Compliant with USB 3.0 and 2.0 specifications, with maximum transmission rates up to 5 Gbps on USB 3.0 and 480 Mbps on USB 2.0. ● Used for AT command communication, data transmission, firmware upgrade (USB 2.0 only), software debugging, GNSS NMEA sentence output, and voice* over USB. ● Supports USB serial drivers: <ul style="list-style-type: none"> -Windows 7/8/8.1/10/11 -Linux 2.6–5.18 -Android 4.x–13.x
PCM Interface*	<ul style="list-style-type: none"> ● Used for audio function through external codec ● Supports 16-bit linear data format ● Supports long and short frame synchronization ● Supports master and slave modes, but must be the master in long frame synchronization
PCIe Interface (Optional)	<ul style="list-style-type: none"> ● Compliant with <i>PCI Express Base Specification Revision 4.0</i> ● Supports one PCIe interface, up to 5 Gbps/lane ● Used for data transmission ● RC mode only
Rx-diversity	<ul style="list-style-type: none"> ● EM060K-GL, EM120K-GL and EM060K-EA: <ul style="list-style-type: none"> - LTE/WCDMA

	<ul style="list-style-type: none"> ● EM060K-NA: <ul style="list-style-type: none"> - LTE
Antenna Interfaces	<ul style="list-style-type: none"> ● EM060K-GL and EM120K-GL: <ul style="list-style-type: none"> - Main antenna connector and diversity/GNSS antenna connector - 50 Ω impedance ● EM060K-NA and EM060K-EA: <ul style="list-style-type: none"> - Main antenna connector, Diversity antenna connector, GNSS antenna connector - 50 Ω impedance
Transmitting Power	<ul style="list-style-type: none"> ● WCDMA: Class 3 (23 dBm ±2 dB) ● LTE-FDD/TDD: Class 3 (23 dBm ±2 dB)
LTE Features	<ul style="list-style-type: none"> ● Supports 3GPP Rel-12 LTE-FDD and LTE-TDD ● Supports CA categories: <ul style="list-style-type: none"> - EM060K-GL, EM060K-NA and EM060K-EA: <ul style="list-style-type: none"> Supports up to UL CA Cat 6 Supports up to DL CA Cat 6 - EM120K-GL: <ul style="list-style-type: none"> Supports up to UL CA Cat 13 Supports up to DL CA Cat 12 ● Supports modulations: <ul style="list-style-type: none"> Uplink: <ul style="list-style-type: none"> - EM060K-GL, EM060K-NA and EM060K-EA: QPSK and 16QAM - EM120K-GL: QPSK,16QAM and 64QAM Downlink: <ul style="list-style-type: none"> - EM060K-GL, EM060K-NA and EM060K-EA: QPSK,16QAM and 64QAM - EM120K-GL: QPSK, 16QAM,64QAM and 256QAM ● Supports 1.4/3/5/10/15/20 MHz RF bandwidths ● Max. transmission data rates ⁴: <ul style="list-style-type: none"> - EM060K-GL, EM060K-NA and EM060K-EA: <ul style="list-style-type: none"> LTE-FDD: 300 Mbps (DL)/50 Mbps (UL) LTE-TDD: 226 Mbps (DL)/28 Mbps (UL) - EM120K-GL: <ul style="list-style-type: none"> LTE-FDD: 600 Mbps (DL)/150 Mbps (UL) LTE-TDD: 430 Mbps (DL)/90 Mbps (UL)
UMTS Features ⁵	<ul style="list-style-type: none"> ● EM060K-GL, EM120K-GL and EM060K-EA: <ul style="list-style-type: none"> ● Supports 3GPP Rel-9 DC-HSDPA, HSPA+, HSDPA, HSUPA and WCDMA ● Supports modulations: <ul style="list-style-type: none"> - DL: BPSK, QPSK, 16QAM and 64QAM - UL: BPSK, QPSK

⁴ The maximum rates are theoretical and the actual values refer to the network configuration.

⁵ EM060K-NA does not support WCDMA.

	<ul style="list-style-type: none"> ● Max. transmission data rates: <ul style="list-style-type: none"> - DC-HSDPA: 42 Mbps (DL) - HSUPA: 5.76 Mbps (UL) - WCDMA: 384 kbps (DL)/384 kbps (UL)
GNSS Features	<ul style="list-style-type: none"> ● Supports GPS, GLONASS, BDS and Galileo ● Data update rate: 1 Hz by default
AT Commands	<ul style="list-style-type: none"> ● Compliant with 3GPP TS 27.007 and 3GPP TS 27.005 ● Quectel enhanced AT commands
Internet Protocol Features	QMI/MBIM/NITZ/HTTP/HTTPS/FTP/LwM2M/PING
Firmware Upgrade	Via USB 2.0 or DFOTA
SMS	<ul style="list-style-type: none"> ● Point-to-point MO and MT ● Text and PDU Modes ● SMS cell broadcast ● SMS storage: ME by default
Physical Characteristics	<ul style="list-style-type: none"> ● M.2 Key-B ● Size: 30.0 mm × 42.0 mm × 2.3 mm ● Weight: approx. 6.2 g
Temperature Range	<ul style="list-style-type: none"> ● Operating temperature range: -25 to +75 °C ⁶ ● Extended temperature range: -40 to +85 °C ⁷ ● Storage temperature range: -40 to +90 °C
RoHS	All hardware components are fully compliant with EU RoHS directive

6 To meet this operating temperature range, you need to ensure effective thermal dissipation, for example, by adding passive or active heatsinks, heat pipes, vapor chambers, etc. Within this range, the module can meet 3GPP specifications.

7 To meet this extended temperature range, you need to ensure effective thermal dissipation, for example, by adding passive or active heatsinks, heat pipes, vapor chambers, etc. Within this range, the module remains the ability to establish and maintain functions such as voice*, SMS, emergency call* etc., without any unrecoverable malfunction. Radio spectrum and radio network are not influenced, while one or more specifications, such as P_{out}, may undergo a reduction in value, exceeding the specified tolerances of 3GPP. When the temperature returns to the normal operating temperature level, the module will meet 3GPP specifications again.

2.3. Functional Diagram

The following figure shows a functional diagram of EM060K series and EM120K-GL.

- Power management
- Baseband
- LPDDR2 SDRAM+NAND flash
- Radio frequency
- M.2 Key-B interface

2.4. Pin Assignment

The following figure shows the pin assignment of the module.

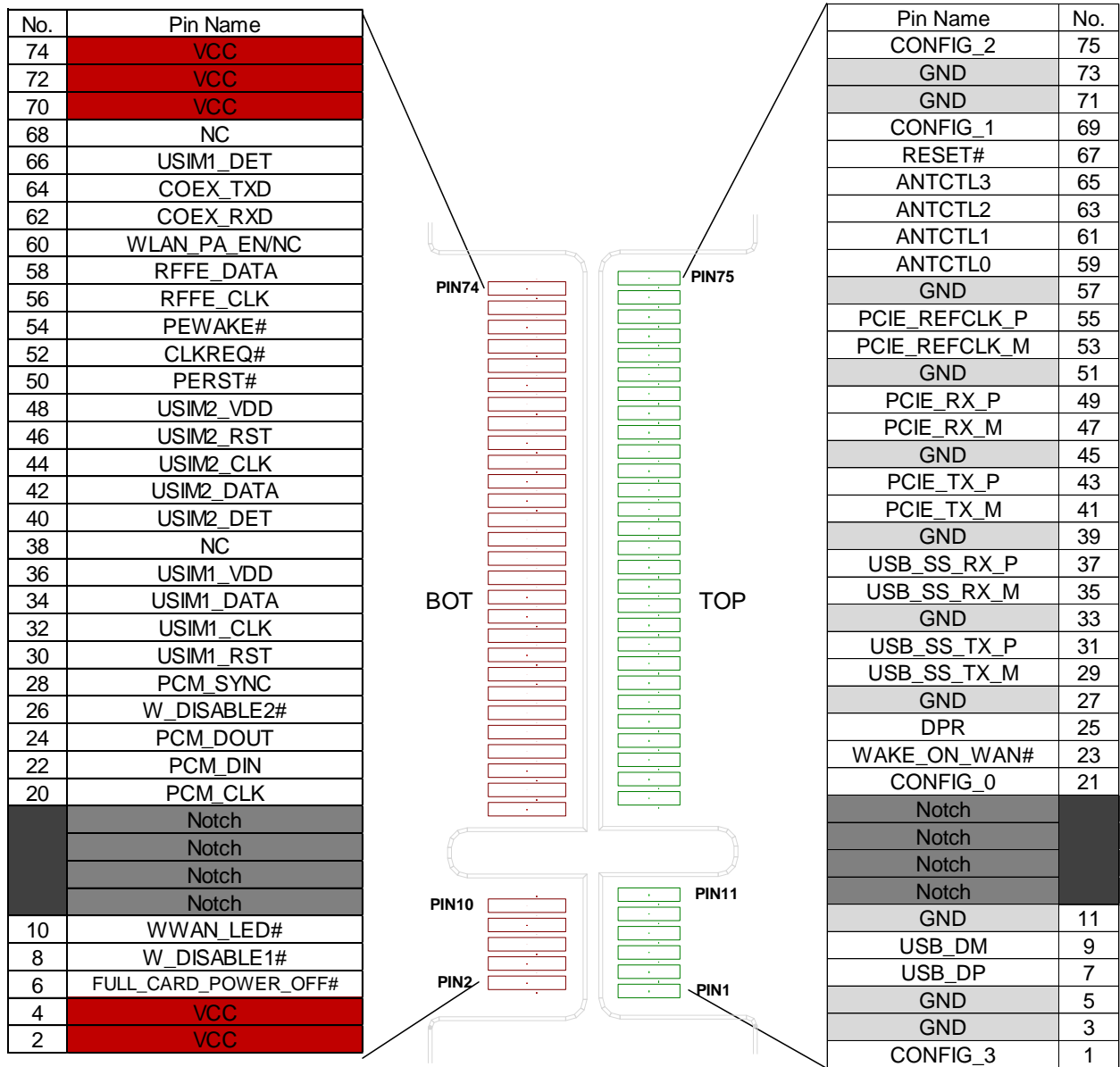

Figure 3: Pin Assignment

NOTE

EM060K-GL and EM120K-GL have conflicts between B46 and 5 GHz frequency bands of WLAN, so you need to set WLAN_PA_EN on pin 60, which mainly controls the coexistence of the two. However,

due to EM060K-NA and EM060K-EA does not support B46, it does not conflict with the 5 GHz frequency bands of WLAN, Pin 60 is not needed. So it is NC.

2.5. Pin Description

Table 4: Definition of I/O Parameters

Type	Description
AI	Analog Input
AO	Analog Output
AIO	Analog Input/Output
DI	Digital Input
DO	Digital Output
DIO	Digital Input/Output
OD	Open Drain
PI	Power Input
PO	Power Output
PU	Pull Up
PD	Pull Down

DC characteristics include power domain and rate current, etc.

Table 5: Pin Description

Pin No.	Pin Name	I/O	Description	DC Characteristic	Comment
1	CONFIG_3	DO	Not connected internally		
2	VCC	PI	Power supply for the module	Vmin = 3.135 V Vnom = 3.7 V Vmax = 4.4 V	

3	GND		Ground		
4	VCC	PI	Power supply for the module	V _{min} = 3.135 V V _{nom} = 3.7 V V _{max} = 4.4 V	
5	GND		Ground		
6	FULL_CARD_POWER_OFF#	DI, PD	Turn on/off the module	V _{IHmax} = 4.4 V V _{IHmin} = 1.19 V V _{ILmax} = 0.2 V	Internally pulled down with a 100 kΩ resistor. High level: turn on Low level: turn off.
7	USB_DP	AIO	USB differential data (+)		A test point must be reserved.
8	W_DISABLE1#	DI, PU	Airplane mode control	V _{IHmin} = 1.8 V V _{ILmax} = 0.4 V V _{ILmin} = -0.4 V	Active low.
9	USB_DM	AIO	USB differential data (-)		A test point must be reserved.
10	WWAN_LED#	OD	RF status LED indicator	VCC	Active low.
11	GND		Ground		
12	Notch		Notch		
13	Notch		Notch		
14	Notch		Notch		
15	Notch		Notch		
16	Notch		Notch		
17	Notch		Notch		
18	Notch		Notch		
19	Notch		Notch		
20	PCM_CLK*	DIO, PD	PCM clock	1.8 V	
21	CONFIG_0	DO	Connected to GND internally		
22	PCM_DIN*	DI, PD	PCM data input	1.8 V	
23	WAKE_ON_WAN#	OD	Wake up the host	1.8/3.3 V	Active low.

24	PCM_DOUT*	DO, PD	PCM data output	1.8 V	
25	DPR	DI, PU	Dynamic power reduction	1.8 V	High level by default. Active low.
26	W_DISABLE2#	DI, PU	GNSS control	$V_{IHmin} = 1.8\text{ V}$ $V_{ILmax} = 0.4\text{ V}$ $V_{ILmin} = -0.4\text{ V}$	Active low.
27	GND		Ground		
28	PCM_SYNC*	DIO, PD	PCM data frame sync	1.8 V	
29	USB_SS_TX_M	AO	USB 3.0 super-speed transmit (-)		
30	USIM1_RST	DO, PD	(U)SIM1 card reset	USIM1_VDD 1.8/3.0 V	
31	USB_SS_TX_P	AO	USB 3.0 super-speed transmit (+)		
32	USIM1_CLK	DO, PD	(U)SIM1 card clock	USIM1_VDD 1.8/3.0 V	
33	GND		Ground		
34	USIM1_DATA	DIO, PD	(U)SIM1 card data	USIM1_VDD 1.8/3.0 V	
35	USB_SS_RX_M	AI	USB 3.0 super-speed receive (-)		
36	USIM1_VDD	PO	(U)SIM1 card power supply	1.8/3.0 V	
37	USB_SS_RX_P	AI	USB 3.0 super-speed receive (+)		
38	NC		Not connected		
39	GND		Ground		
40	USIM2_DET ⁸	DI, PD	(U)SIM2 card hot-plug detect	1.8 V	Internally pulled up to 1.8 V.
41	PCIE_TX_M	AO	PCIe transmit (-)		
42	USIM2_DATA	DIO, PD	(U)SIM2 card data	USIM2_VDD 1.8/3.0 V	
43	PCIE_TX_P	AO	PCIe transmit (+)		

⁸ This pin is pulled low by default, and will be internally pulled up to 1.8 V by software configuration only when (U)SIM hot-swap is enabled by **AT+QSIMDET**. For more details, see **document [3]**.

44	USIM2_CLK	DO, PD	(U)SIM2 card clock	USIM2_VDD 1.8/3.0 V	
45	GND		Ground		
46	USIM2_RST	DO, PD	(U)SIM2 card reset	USIM2_VDD 1.8/3.0 V	
47	PCIE_RX_M	AI	PCIe receive (-)		
48	USIM2_VDD	PO	(U)SIM2 card power supply	1.8/3.0 V	
49	PCIE_RX_P	AI	PCIe receive (+)		
50	PERST#	DO	PCIe reset	1.8/3.3 V	RC mode only.
51	GND		Ground		
52	CLKREQ#	DI	PCIe clock request	1.8/3.3 V	
53	PCIE_REFCLK_M	AO	PCIe reference clock (-)		
54	PEWAKE#	DI	PCIe wake up	1.8/3.3 V	
55	PCIE_REFCLK_P	AO	PCIe reference clock (+)		
56	RFFE_CLK* ⁹	DO, PD	Used for external MIPI IC control	1.8 V	
57	GND		Ground		
58	RFFE_DATA* ⁹	DIO, PD	Used for external MIPI IC control	1.8 V	
59	ANTCTL0*	DO, PD	Antenna GPIO control	1.8 V	
60	WLAN_PA_EN	DI, PD	Self-protection of QLN control	1.8 V	It is not connected for EM060K-NA and EM060K-EA.
61	ANTCTL1*	DO, PD	Antenna GPIO control	1.8 V	
62	COEX_RXD*	DI, PD	LTE/WLAN coexistence receive	1.8 V	
63	ANTCTL2*	DO, PD	Antenna GPIO control	1.8 V	
64	COEX_TXD*	DO, PD	LTE/WLAN coexistence transmit	1.8 V	

⁹ If RFFE_CLK and RFFE_DATA are required, please contact Quectel for more details.

65	ANTCTL3*	DO, PD	Antenna GPIO control	1.8 V	
66	USIM1_DET ⁸	DI, PD	(U)SIM1 card hot-plug detect	1.8 V	Internally pulled up to 1.8 V.
67	RESET#	DI, PU	Reset the module	V _{IHmax} = 2.1 V V _{IHmin} = 1.3 V V _{ILmax} = 0.5 V	Internally pulled up to 1.8 V with a 10 kΩ resistor. Active low. A test point is recommended to be reserved if unused.
68	NC		Not connected		
69	CONFIG_1	DO	Connected to GND internally		
70	VCC	PI	Power supply for the module	V _{min} = 3.135 V V _{nom} = 3.7 V V _{max} = 4.4 V	
71	GND		Ground		
72	VCC	PI	Power supply for the module	V _{min} = 3.135 V V _{nom} = 3.7 V V _{max} = 4.4 V	
73	GND		Ground		
74	VCC	PI	Power supply for the module	V _{min} = 3.135 V V _{nom} = 3.7 V V _{max} = 4.4 V	
75	CONFIG_2	DO	Not connected internally		

NOTE

Keep all NC and unused pins unconnected.

2.6. EVB Kit

To help you develop applications conveniently with EM060K series and EM120K-GL, Quectel supplies an evaluation board (5G-M2 EVB). For more details, see **document [2]**.

3 Operating Characteristics

3.1. Operating Modes

The table below summarizes different operating modes of the modules.

Table 6: Overview of Operating Modes

Mode	Details
Full Functionality Mode	Idle Software is active. The module is registered on the network and is ready to send and receive data.
	Voice*/Data Network is connected. In this mode, the power consumption is determined by network setting and data transfer rate.
Minimum Functionality Mode	AT+CFUN=0 sets the module to a minimum functionality mode without removing the power supply. In this mode, both RF function and (U)SIM card are invalid.
Airplane Mode	AT+CFUN=4 or driving W_DISABLE1# pin low will set the module to airplane mode. In this mode, the RF function is invalid.
Sleep Mode	In this mode, current consumption of the module will be reduced to the minimal level. The module can still receive paging, SMS, voice* call and TCP/UDP data from network.
Power Down Mode	In this mode, the power management unit shuts down the power supply. Software is inactive, while all interfaces are inaccessible and the operating voltage (connected to VCC) remains applied.

For more details, see *document [3]*.

3.2. Sleep Mode

In sleep mode, DRX (Discontinuous Reception) of the module is able to reduce the current consumption to a minimum level, and DRX cycle index values are broadcasted by the wireless network. The figure below shows the relationship between the DRX run time and the current consumption in sleep mode. The longer the DRX cycle is, the lower the current consumption will be.

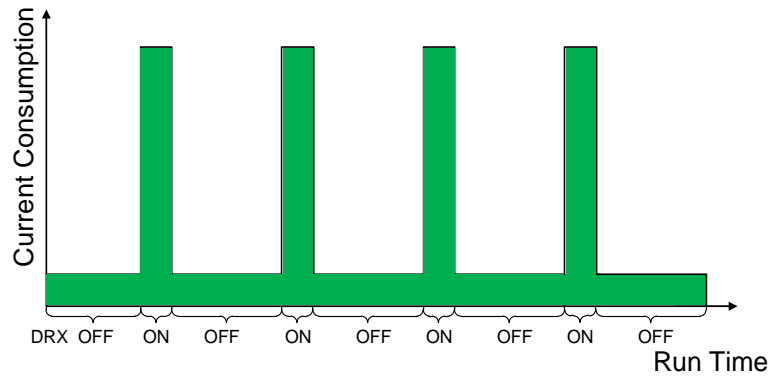

Figure 4: DRX Run Time and Current Consumption in Sleep Mode

The following part of this chapter describes the power saving procedure and sleep mode entrance of the module.

If the host supports USB suspend/resume and remote wakeup function, the following two conditions must be met simultaneously to bring the module into sleep mode.

- Execute **AT+QSCLK=1** to enable the sleep mode. For more details, see **document [3]**.
- Ensure the host’s USB bus, which is connected to the module’s USB interface, enters suspend state.

The following figure shows the connection between the module and the host.

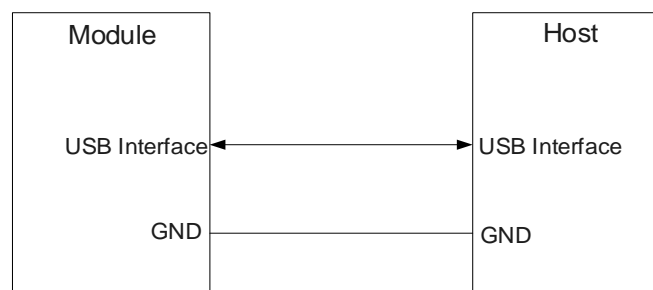

Figure 5: Sleep Mode Application with USB Remote Wakeup Function

The module will wake up when the host sends data to the module through USB interface.

3.3. Airplane Mode

Execution of **AT+CFUN=4** or driving W_DISABLE1# pin low will set the module to airplane mode. For more details, see **Chapter 4.4.1**.

3.4. Communication Interface with Host

The module supports communication with the host through USB interface. USB 2.0 should be reserved for firmware upgrade. See the USB mode features as below:

USB Mode:

- Supports all USB 2.0 and 3.0 features
- Supports MBIM/QMI/QRTR/AT

3.5. Power Supply

3.5.1. Power Supply Pins

Table 7: Definition of VCC and GND Pins

Pin No.	Pin Name	I/O	Description	Comment
2, 4, 70, 72, 74	VCC	PI	Power supply for the module	Vmin = 3.135 V Vnom = 3.7 V Vmax = 4.4 V
3, 5, 11, 27, 33, 39, 45, 51, 57, 71, 73	GND		Ground	

3.5.2. Reference Design for Power Supply

Power design is vital to the module, as the performance of the module largely depends on the power source. The power supply of the module should be able to provide a sufficient current of 2 A at least. In case of a slight difference between input and output voltages, use an LDO when supplying power to the module. In case of a large difference between input and desired output (typically 3.7 V) voltages, using a buck DC-DC converter is preferred.

The performance of the module largely depends on the power supply design. The continuous current of the power supply should be 3 A at least and the peak current should be 4 A at least.

The following figure shows a reference design for +5 V input power supply based on DC-DC converter. The typical output of the power supply is about 3.7 V.

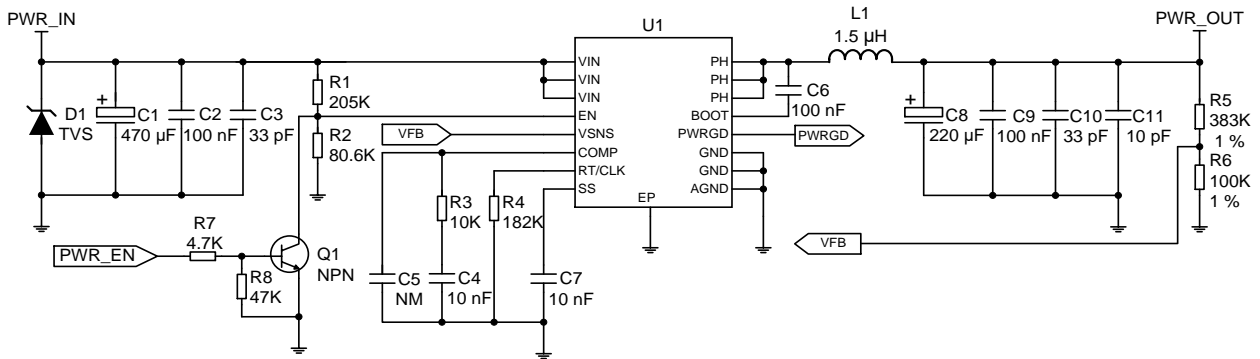

Figure 6: Reference Circuit for Power Supply

NOTE

To avoid corrupting the data in the internal flash, do not cut off the power supply before the module is completely turned off by pulling down FULL_CARD_POWER_OFF# pin for more than 6.6 s, and do not cut off power supply directly when the module is working.

3.5.3. Voltage Stability Requirements

The power supply of the module ranges from 3.135 V to 4.4 V. Please ensure that the input voltage never drops below 3.135 V, otherwise the module will be powered off automatically. The following figure shows the maximum voltage drop during burst transmission in 3G/4G networks.

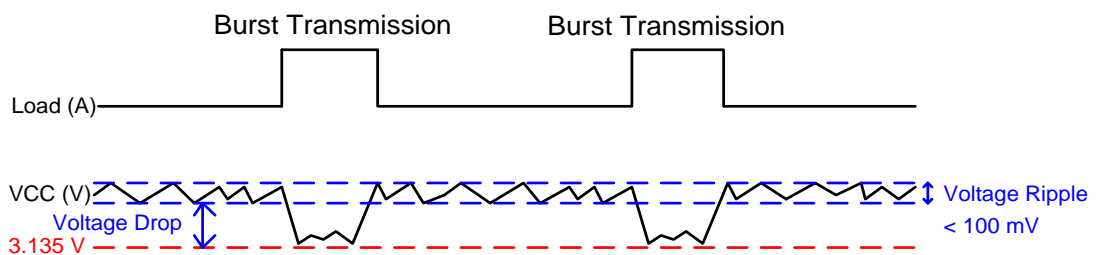

Figure 7: Power Supply Limits During Burst Transmission

To decrease the voltage drop, two bypass capacitors of about 220 μ F with low ESR (ESR = 0.7 Ω) should be used. To avoid disturbing the power supply, two multi-layer ceramic chip capacitor (MLCC) arrays also should be used due to their ultra-low ESR. It is recommended to use eight ceramic capacitors (1 μ F, 100 nF, 33 pF, 10 pF) to compose the MLCC arrays, and to place these capacitors close to VCC pins. The width of VCC trace should be no less than 2.5 mm. In principle, the longer the VCC trace is, the wider it

should be.

In addition, to guarantee the stability of the power supply, please use a TVS component with a reverse TVS voltage of 5.1 V and a dissipation power higher than 0.5 W. The following figure shows a reference circuit of the VCC.

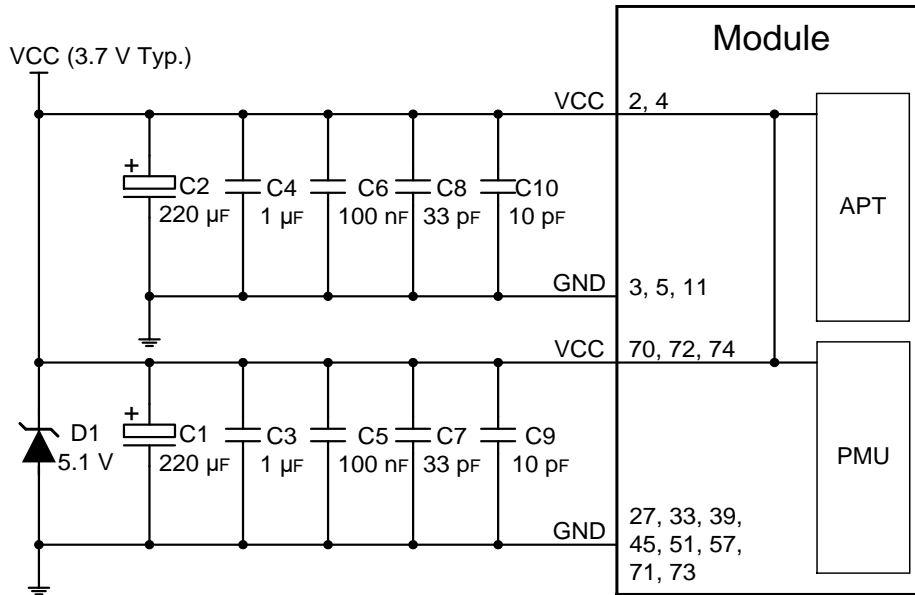

Figure 8: Reference Circuit for VCC Pins

3.5.4. Monitor the Power Supply

You can use **AT+CBC** to monitor the voltage value of VCC. For more details, see **document [3]**.

3.6. Turn-on

FULL_CARD_POWER_OFF# serves to turn on/off the module. This input signal is 3.3 V tolerant and can be driven by either 1.8 V or 3.3 V GPIO. Also, it has been internally pulled down with a 100 kΩ resistor.

When FULL_CARD_POWER_OFF# is de-asserted (driven high, ≥ 1.19 V), the module will be turned on.

Table 8: Pin Definition of FULL_CARD_POWER_OFF#

Pin No.	Pin Name	I/O	Description	Comment
6	FULL_CARD_POWER_OFF#	DI, PD	Turn on/off the module	Internally pulled down with a 100 kΩ resistor.

High level: turn on

Low level: turn off.

It is recommended to use a host GPIO to control FULL_CARD_POWER_OFF#. A simple reference circuit is illustrated in the following figure.

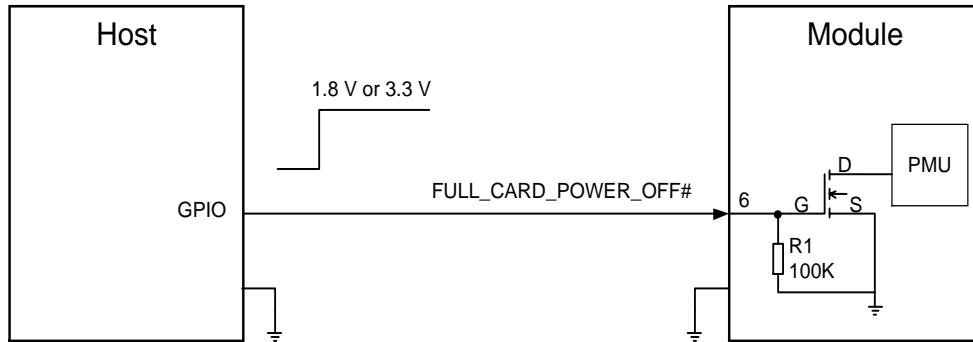

Figure 9: Turn On the Module with a Host GPIO

NOTE

The voltage of pin 6 of the module should be not less than 1.19 V when it is at high level.

The turn-on timing is illustrated in the following figure.

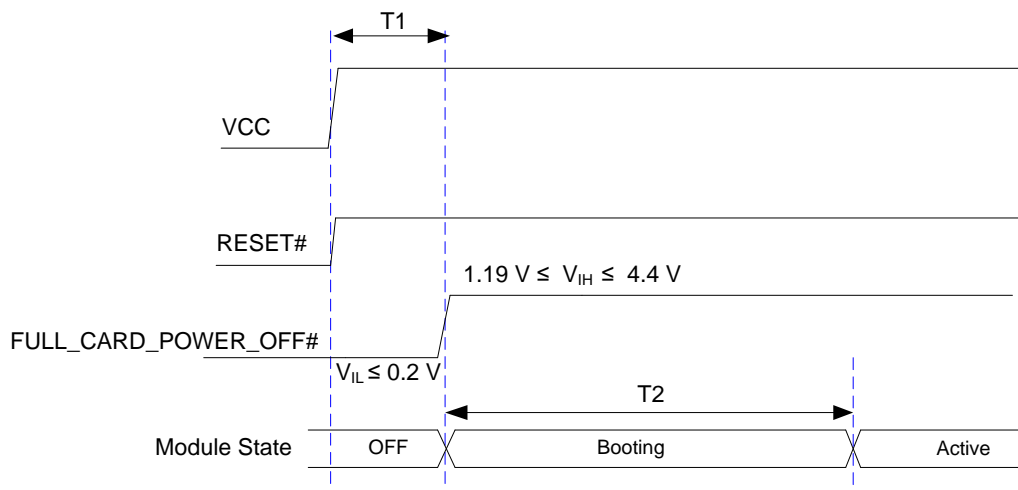

Figure 10: Turn-on Timing

Table 9: Turn-on Timing of the Module

Symbol	Min.	Typ.	Max.	Comment
T1	100 ms	-	-	The turn-on time of the module.
T2	-	13.7s	-	The system booting time of the module.

NOTE

RESET# is automatically pulled up as on as the module is powered on. RESET# is not allowed to be pulled down by host during powering up

3.7. Turn-off

If the module is turned off using a host GPIO, when VCC is supplied with power, pulling down FULL_CARD_POWER_OFF# pin (≤ 0.2 V) will turn off the module normally. The turn-off timing is illustrated in the following figure.

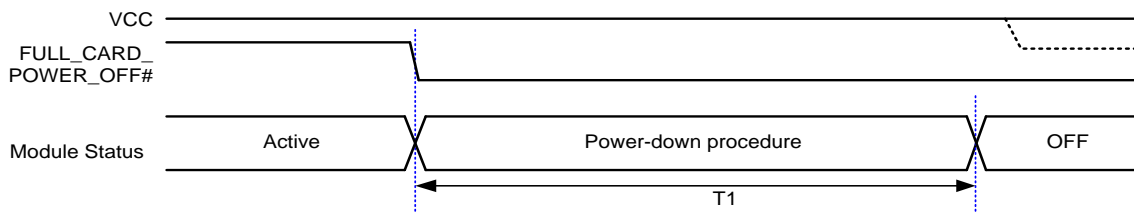

Figure 11: Turn-off Timing

NOTE

As shown by the dotted line, it is suggested to disconnect VCC and drive RESET# low after the module shuts down.

Table 10: Turn-off Timing of the Module

Symbol	Min.	Typ.	Max.	Comment
T1	-	1 s	-	The turn-off time of the module

3.8. Reset

The RESET# pin serves to reset the module. Triggering the RESET# signal will lead to loss of all data from the modem and removal of system drivers. It will also lead to disconnection of the modem from the network.

Table 11: Pin Definition of RESET#

Pin No.	Pin Name	I/O	Description	Comment
67	RESET#	DI, PU	Reset the module	Internally pulled up to 1.8 V with a 10 kΩ resistor. Active low. A test point is recommended to be reserved if unused.

The module can be reset by pulling down the RESET# pin for 200–600 ms. An open collector (OC)/drain driver or a button can be used to control the RESET# pin.

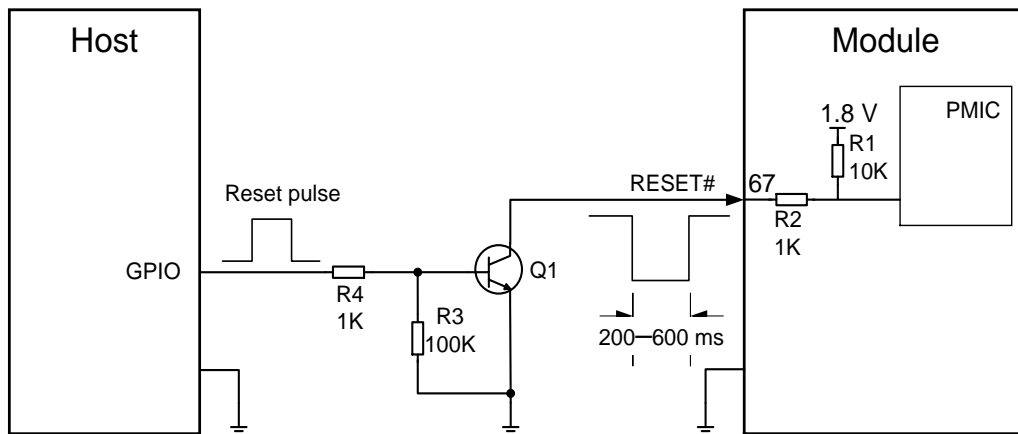

Figure 12: Reference Circuit of RESET# with Open Collector Driving Circuit

The reset timing is illustrated in the following figure.

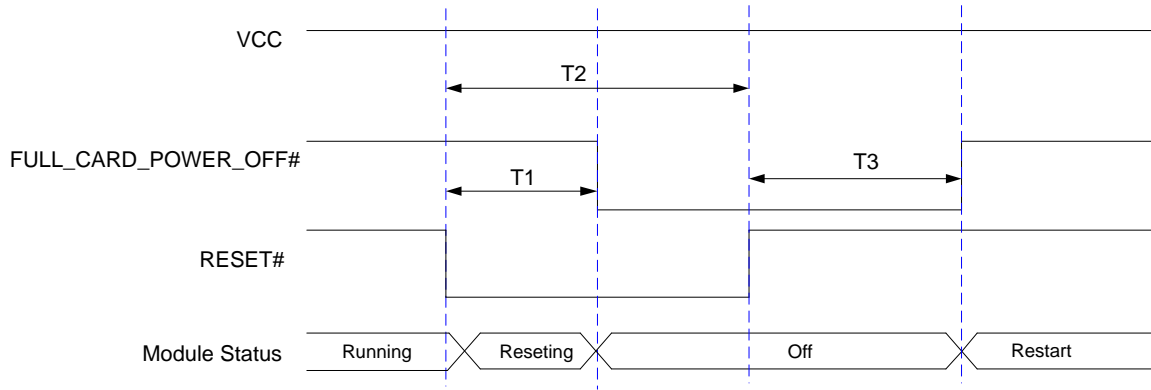

Figure 13: Reset Timing

Table 12: Reset Timing of the Module

Index	Min.	Typ.	Max.	Comment
T1	0 ms	100 ms	-	It is recommended to pull down RESET# for about 100 ms before driving FULL_CARD_POWER_OFF# low.
T2	200 ms	-	600 ms	Driving RESET# low for 200–600 ms can reset the module.
T3	-	50 ms	-	Set up by the host, 50 ms by default.

4 Application Interfaces

4.1. (U)SIM Interface

The (U)SIM interface circuitry meets ETSI and IMT-2000 requirements and *ISO/IEC 7816-3*. Both Class B (3.0 V) and Class C (1.8 V) (U)SIM cards are supported, and Dual SIM Single Standby function is supported.

4.1.1. Pin definition of (U)SIM

Table 13: Pin Definition of (U)SIM Interfaces

Pin No.	Pin Name	I/O	Description
36	USIM1_VDD	PO	(U)SIM1 card power supply
34	USIM1_DATA	DIO, PD	(U)SIM1 card data
32	USIM1_CLK	DO, PD	(U)SIM1 card clock
30	USIM1_RST	DO, PD	(U)SIM1 card reset
66	USIM1_DET	DI, PD	(U)SIM1 card hot-plug detect
40	USIM2_DET	DI, PD	(U)SIM2 card hot-plug detect
42	USIM2_DATA	DIO, PD	(U)SIM2 card data
44	USIM2_CLK	DO, PD	(U)SIM2 card clock
46	USIM2_RST	DO, PD	(U)SIM2 card reset
48	USIM2_VDD	PO	(U)SIM2 card power supply

4.1.2. (U)SIM Hot-swap

The module supports (U)SIM card hot-swap via (U)SIM card hot-swap detect pins USIM1_DET and USIM2_DET. (U)SIM card insertion can be detected by high/low level. (U)SIM card hot-swap function is disabled by default.

The following command configures (U)SIM card hot-swap detection.

AT+QSIMDET Configure (U)SIM Card Hot-Swap Detection	
Test Command AT+QSIMDET=?	Response +QSIMDET: (list of supported <enable>s),(list of supported <insert_level>s) OK
Read Command AT+QSIMDET?	Response +QSIMDET: <enable> , <insert_level> OK
Write Command AT+QSIMDET=<enable>,<insert_level>	Response OK If there is any error: ERROR
Maximum Response Time	300 ms
Characteristics	The command takes effect after the module is rebooted. The configuration will be saved automatically.

Parameter

<enable>	Integer type. Enable or disable (U)SIM card detection. <u>0</u> Disable 1 Enable
<insert_level>	Integer type. The level of (U)SIM detection pin when a (U)SIM card is inserted. <u>0</u> Low level 1 High level

NOTE

1. Hot-swap function is invalid if the configured value of `<insert_level>` is inconsistent with hardware design.
2. The underlined value represents the default configuration.
3. USIM1_DET and USIM2_DET are pulled low by default, and will be internally pulled up to 1.8 V by software configuration only when (U)SIM hot-swap is enabled by **AT+QSIMDET**. For more details, see *document [3]*.

4.1.3. Normally Closed (U)SIM Card Connector

With a normally closed (U)SIM card connector, USIM_DET pin is normally shorted to ground when there is no (U)SIM card inserted. (U)SIM card detection by high level is applicable to this type of connector. Once (U)SIM hot-swap is enabled by executing **AT+QSIMDET=1,1**, insertion of a (U)SIM card will drive USIM_DET from low to high level, and the removal of it will drive USIM_DET from high to low level.

- When the (U)SIM is absent, CD is shorted to ground and USIM_DET is at low level.
- When the (U)SIM is present, CD is open from ground and USIM_DET is at high level.

The following figure shows a reference design of (U)SIM interface with a normally closed (U)SIM card connector.

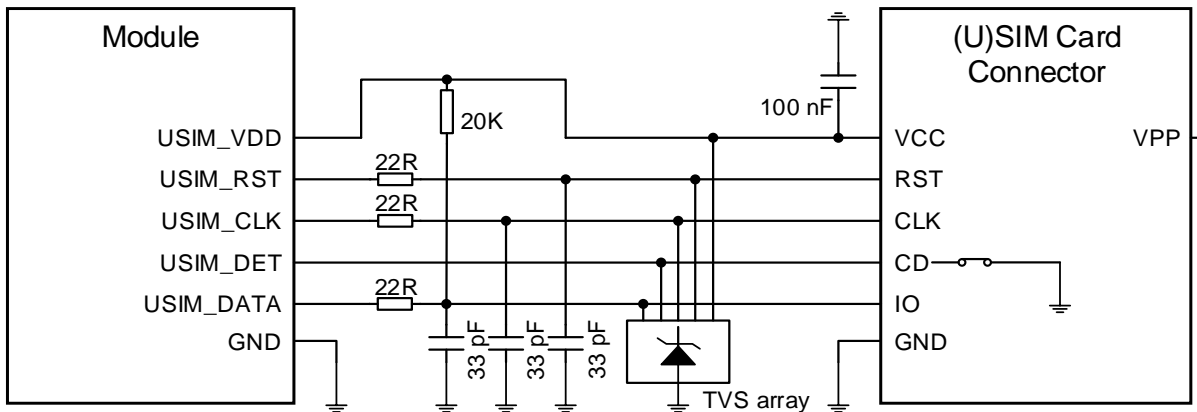

Figure 14: Reference Circuit for Normally Closed (U)SIM Card Connector

NOTE

All these resistors, capacitors and TVS array in the reference circuit should be close to (U)SIM card connector in PCB layout.

4.1.4. Normally Open (U)SIM Card Connector

With a normally open (U)SIM card connector, CD1 and CD2 of the connector are disconnected when there is no (U)SIM card inserted. (U)SIM card detection by low level is applicable to this type of connector. Once (U)SIM hot-swap is enabled by executing **AT+QSIMDET=1,0**, insertion of a (U)SIM card will drive USIM_DET from high to low level, and the removal of it will drive USIM_DET from low to high level.

- When the (U)SIM is absent, CD1 is open from CD2 and USIM_DET is at high level.
- When the (U)SIM is inserted, CD1 is shorted to ground and USIM_DET is at low level.

The following figure shows a reference design of (U)SIM interface with a normally open (U)SIM card connector.

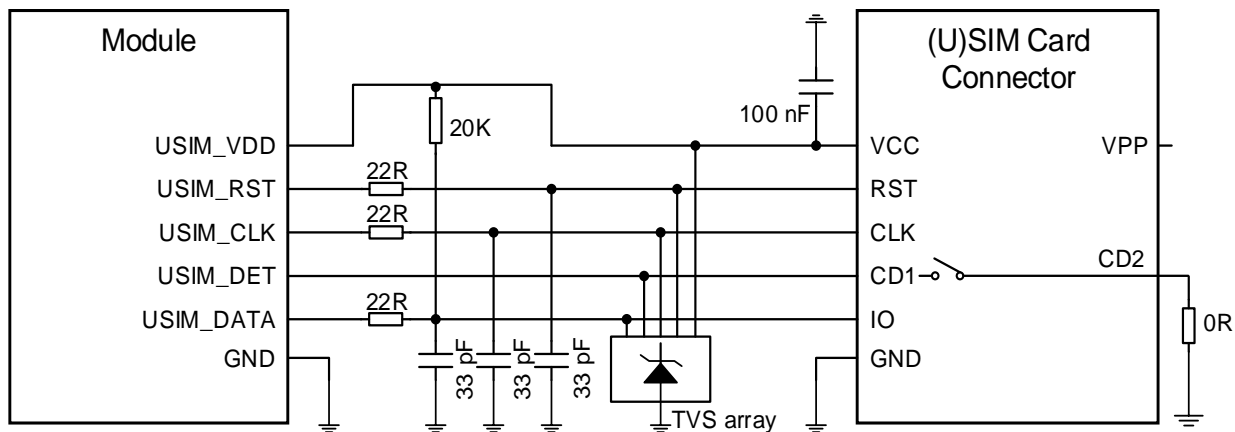

Figure 15: Reference Circuit for Normally Open (U)SIM Card Connector

NOTE

All these resistors, capacitors and TVS array in the reference circuit should be close to (U)SIM card connector in PCB layout.

4.1.5. (U)SIM Card Connector Without Hot-swap

If the (U)SIM card detection function is not needed, please keep USIM_DET unconnected. A reference circuit for the (U)SIM card interface with a 6-pin (U)SIM card connector is illustrated by the following figure.

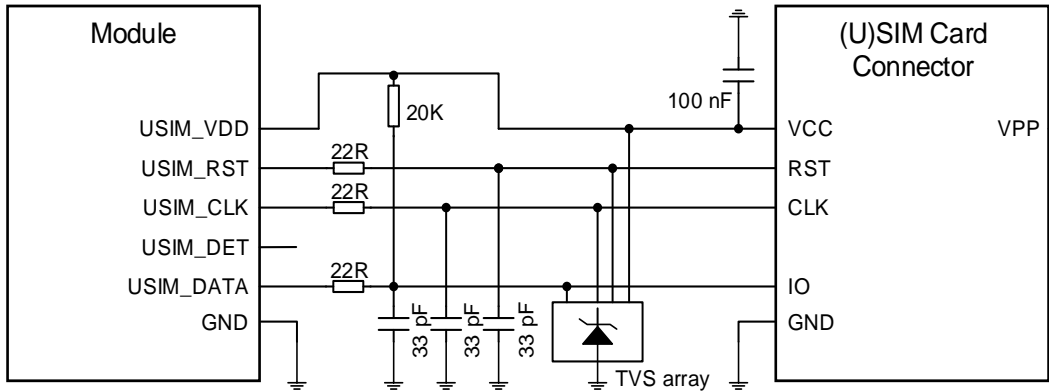

Figure 16: Reference Circuit for 6-Pin (U)SIM Card Connector

NOTE

All these resistors, capacitors and TVS array in the reference circuit should be close to (U)SIM card connector in PCB layout.

4.1.6. (U)SIM2 Card Compatible Design

It should be noted that if the (U)SIM2 interface is used for an external (U)SIM card, the circuits are the same as those of (U)SIM1 interface. if the (U)SIM2 interface is used for an internal eSIM card, pins 40, 42, 44, 46 and 48 of the module must be kept open.

A recommended compatible design for the (U)SIM2 interface is shown below.

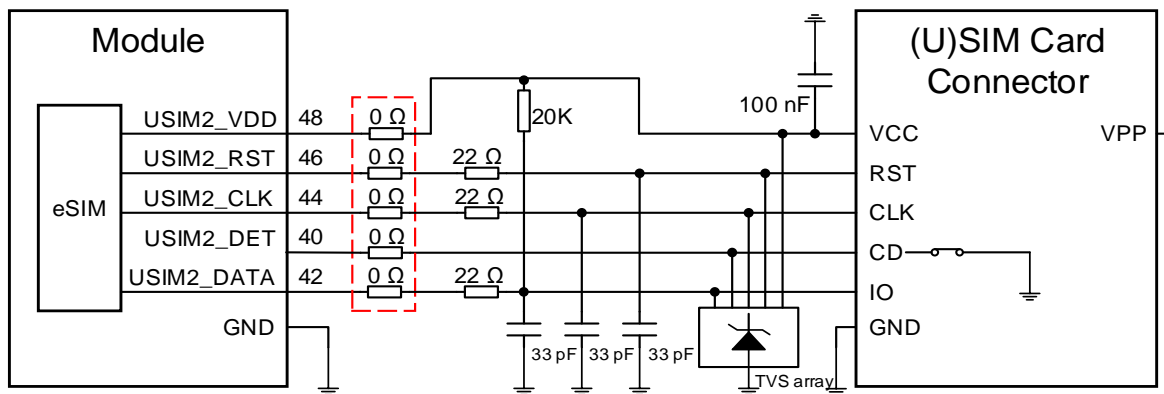

Figure 17: Recommended Compatible Design for (U)SIM2 Interface

NOTE

The five 0 Ω resistors must be close to the module, and all other components should be close to (U)SIM card connector in PCB layout.

4.1.7. (U)SIM Design Notices

To enhance the reliability and availability of the (U)SIM card in applications, please follow the criteria below in (U)SIM circuit design.

- Place the (U)SIM card connector as close to the module as possible. Keep the trace length less than 200 mm if possible.
- Keep (U)SIM card signals away from RF and VCC traces.
- Ensure the ground between the module and the (U)SIM card connector is short and wide. Keep the trace width of ground and USIM_VDD not less than 0.5 mm to maintain the same electric potential.
- To avoid cross-talk between USIM_DATA and USIM_CLK, keep them away from each other and shield them with surrounded ground.
- To offer better ESD protection, add a TVS array of which the parasitic capacitance should be less than 10 pF. Add 22 Ω resistors in series between the module and the (U)SIM card connector to facilitate debugging. The 33 pF capacitors are used to filter out RF interference. Additionally, keep the (U)SIM peripheral circuit close to the (U)SIM card connector.
- For USIM_DATA, it is recommended to add a 20 kΩ pull-up resistor near the (U)SIM card connector to improve the anti-jamming capability of the (U)SIM card.
- The (U)SIM card connector should be placed near the M.2 socket, because a long trace may lead to waveform distortion, which affects the signal quality.

4.2. USB Interface

The module provides one integrated Universal Serial Bus (USB) interface which complies with USB 3.0 and 2.0 specifications and supports SuperSpeed (5 Gbps) on USB 3.0 and high-speed (480 Mbps) and full-speed (12 Mbps) modes on USB 2.0. The USB interface is used for AT command communication, data transmission, firmware upgrade (USB 2.0 only), software debugging, GNSS NMEA sentence output, and voice* over USB.

Table 14: Pin Definition of USB Interface

Pin No.	Pin Name	I/O	Description	Comment
7	USB_DP	AIO	USB differential data (+)	Require differential impedance of 90 Ω;
9	USB_DM	AIO	USB differential data (-)	Test points must be reserved.

29	USB_SS_TX_M	AO	USB 3.0 super-speed transmit (-)	
31	USB_SS_TX_P	AO	USB 3.0 super-speed transmit (+)	Require differential impedance of 90 Ω.
35	USB_SS_RX_M	AI	USB 3.0 super-speed receive (-)	
37	USB_SS_RX_P	AI	USB 3.0 super-speed receive (+)	

For more details about the USB 3.0 and 2.0 specifications, please visit <http://www.usb.org/home>.

The following figure presents a reference circuit for the USB interface.

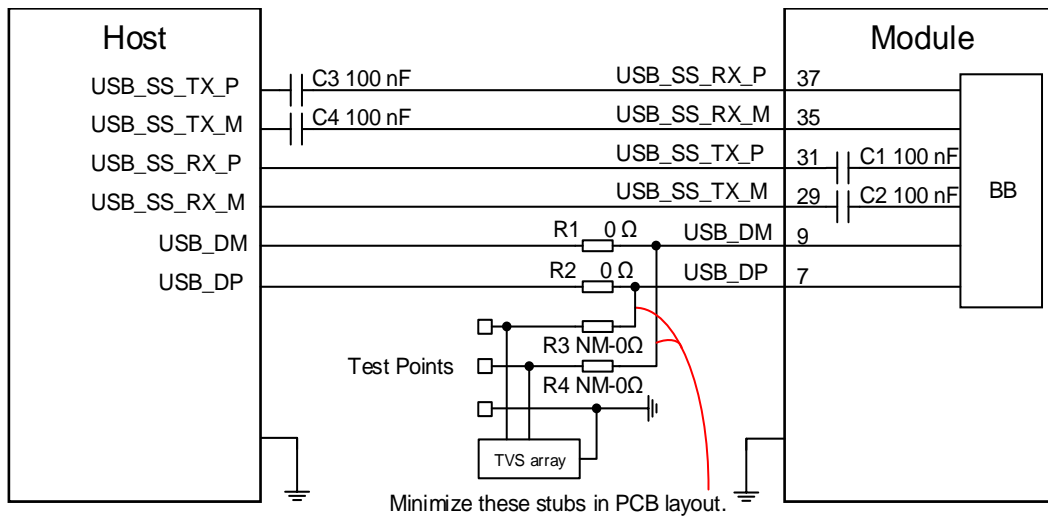

Figure 18: Reference Circuit for USB Interface

AC coupling capacitors C3 and C4 must be placed close to the host and close to each other. C1 and C2 have been integrated inside the module, so do not place these two capacitors on your schematic and PCB. To ensure the signal integrity of USB 2.0 data traces, R1, R2, R3 and R4 must be placed close to the module, and the stubs must be minimized in PCB layout.

Please follow the principles below when designing the USB interface to meet USB 3.0 and 2.0 specifications:

- Route USB signal traces as differential pairs with surrounded ground. The impedance of USB 2.0 and USB 3.0 differential trace is 90 Ω.
- For USB 2.0 signal traces, the trace length should be less than 120 mm, and the differential data pair matching should be less than 2 mm. For USB 3.0 signal traces, the intra-pair length matching (P/M) should be less than 0.7 mm, while the inter-pair length matching (Tx/Rx) should be less than 10 mm.
- Do not route signal traces under crystals, oscillators, magnetic devices, PCIe, other high-speed and RF signal traces. Route the USB differential traces in inner-layer of the PCB, and surround the traces with ground on that layer and with ground planes above and below.

- Junction capacitance of the ESD protection components might cause influences on USB data traces, so you should pay attention to the selection of the components. Typically, the stray capacitance should be less than 1.0 pF for USB 2.0, and less than 0.15 pF for USB 3.0.
- Keep the ESD protection components as close to the USB connector as possible.
- If possible, reserve 0 Ω resistor on USB_DP and USB_DM traces respectively.

4.3. PCM Interface*

The module supports audio communication through external codec via Pulse Code Modulation (PCM) digital interface. The PCM interface supports the following modes:

- Primary mode (short frame synchronization): the module works as both master and slave
- Auxiliary mode (long frame synchronization): the module works as master only

In primary mode, the data is sampled on the falling edge of the PCM_CLK and transmitted on the rising edge. The PCM_SYNC falling edge represents the MSB. In this mode, the PCM interface supports 256 kHz, 512 kHz, 1024 kHz or 2048 kHz PCM_CLK at 8 kHz PCM_SYNC, and also supports 4096 kHz PCM_CLK at 16 kHz PCM_SYNC.

In auxiliary mode, the data is sampled on the falling edge of the PCM_CLK and transmitted on the rising edge. The PCM_SYNC rising edge represents the MSB. In this mode, PCM interface operates only with a 256 kHz PCM_CLK and an 8 kHz, 50 % duty cycle PCM_SYNC.

The module supports 16-bit linear data format. The following figures show the primary mode’s timing relationship with 8 kHz PCM_SYNC and 2048 kHz PCM_CLK, as well as the auxiliary mode’s timing relationship with 8 kHz PCM_SYNC and 256 kHz PCM_CLK.

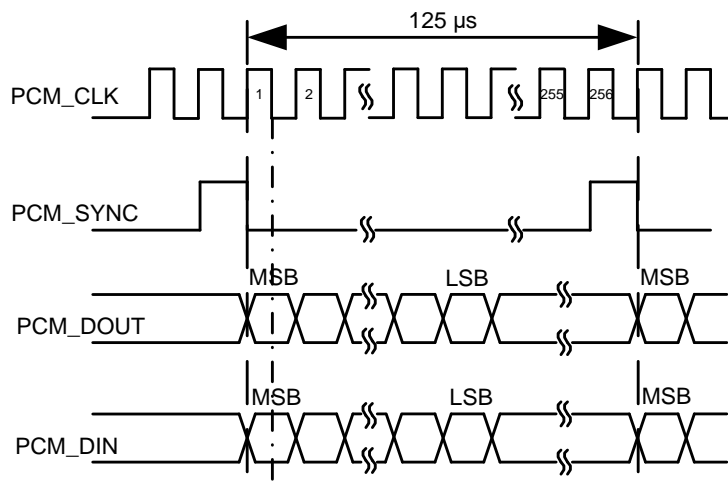

Figure 19: Primary Mode Timing

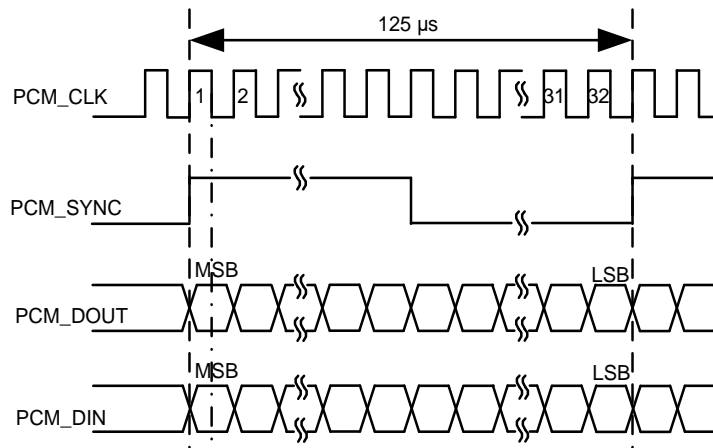

Figure 20: Auxiliary Mode Timing

The following table shows the pin definition of PCM interface which can be applied to audio codec design.

Table 15: Pin Definition of PCM Interface

Pin No.	Pin Name	I/O	Description	Comment
20	PCM_CLK	DIO, PD	PCM clock	
22	PCM_DIN	DI, PD	PCM data input	1.8 V
24	PCM_DOUT	DO, PD	PCM data output	
28	PCM_SYNC	DIO, PD	PCM data frame sync	

The clock and mode can be configured by AT command. The default configuration is master mode using short frame synchronization format with 2048 kHz PCM_CLK and 8 kHz PCM_SYNC. For more details, see **document [3]**.

4.4. Control and Indication Interfaces

Table 16: Pin Definition of Control and Indication Interfaces

Pin No.	Pin Name	I/O	Description	Comment
8	W_DISABLE1#	DI, PU	Airplane mode control	$V_{IHmin} = 1.8 V$ $V_{ILmax} = 0.4 V$ $V_{ILmin} = -0.4 V$

				Active low.
10	WWAN_LED#	OD	RF status indication LED	VCC. Active low.
23	WAKE_ON_WAN#	OD	Wake up the host	1.8/3.3 V. Active low.
25	DPR	DI, PU	Dynamic power reduction	1.8 V, high level by default. Active low.
26	W_DISABLE2#	DI, PU	GNSS control	V _{IHmin} = 1.8 V V _{ILmax} = 0.4 V V _{ILmin} = -0.4 V Active low.
60	WLAN_PA_EN	DI	Self-protection of QLN control	1.8 V

4.4.1. W_DISABLE1#

The module provides a W_DISABLE1# pin to disable or enable airplane mode through hardware operation. W_DISABLE1# is pulled up by default. Driving it low will configure the module into airplane mode. In airplane mode, the RF function will be disabled.

The RF function can also be enabled or disabled through software AT commands. The following table shows the RF function status of the module.

Table 17: RF Function Status

W_DISABLE1# Logic Level	AT Command	RF Function Status	Operating Mode
High Level	AT+CFUN=1	Enable	Full functionality mode
	AT+CFUN=0	Disable	Minimum functionality mode
	AT+CFUN=4	Disable	Airplane mode
Low Level	AT+CFUN=0	Disable	Airplane mode
	AT+CFUN=1		
	AT+CFUN=4		

4.4.2. W_DISABLE2#

The module provides a W_DISABLE2# pin to disable or enable the GNSS function. The W_DISABLE2# pin is pulled up by default. Driving it low will disable the GNSS function.

The GNSS function can also be controlled through software AT commands. The combination of W_DISABLE2# pin and AT commands controls the GNSS function.

Table 18: GNSS Function Status

W_DISABLE2# Logic Level	AT Commands	GNSS Function Status
High Level	AT+QGPS=1	Enable
	AT+QGSEND	
Low Level	AT+QGPS=1	Disable
	AT+QGSEND	

For details about AT commands mentioned above, see **document [4]**.

A simple level-shifting circuit based on diodes is used on W_DISABLE1# pin and W_DISABLE2# pin which are pulled up to a 1.8 V voltage in the module. The control signals (GPIO) of the host device could be at 1.8 V or 3.3 V voltage level. W_DISABLE1# and W_DISABLE2# are active low signals. A reference circuit of the two pins is shown below.

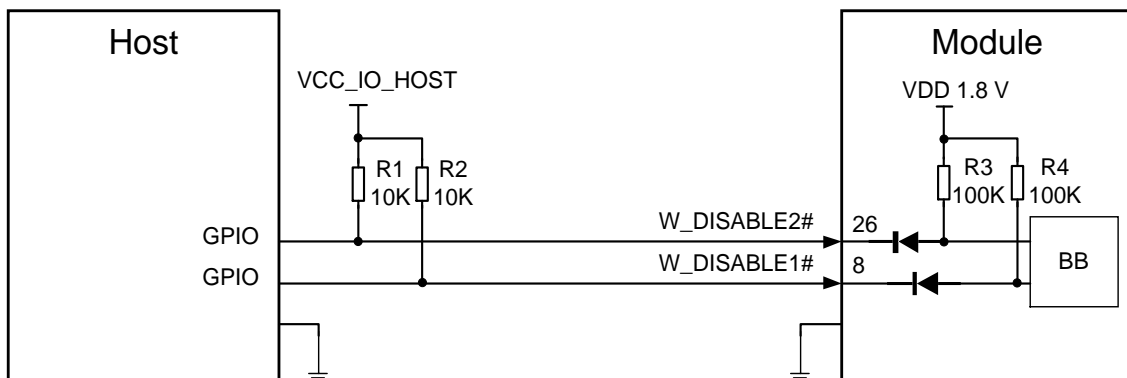

Figure 21: Reference Circuit of W_DISABLE1# and W_DISABLE2#

NOTE

The voltage level of VCC_IO_HOST could be 1.8 V or 3.3 V typically.

4.4.3. WWAN_LED#

The WWAN_LED# signal is used to indicate RF status of the module, and its sink current is up to 10 mA.

To reduce power consumption of the LED, a current-limited resistor must be placed in series with the LED, as illustrated in the figure below. The LED is ON when the WWAN_LED# signal is at low level.

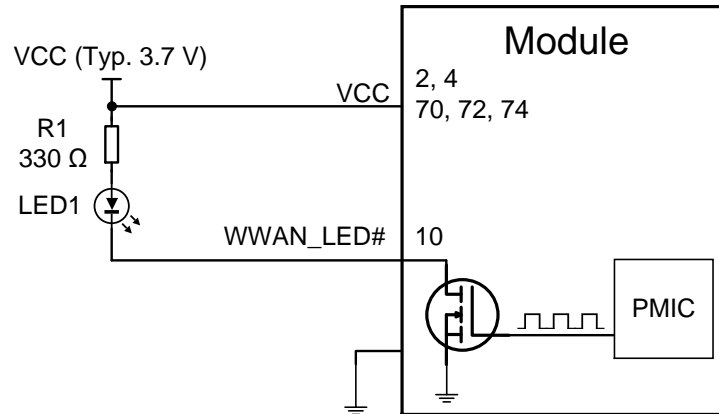

Figure 22: WWAN_LED# Reference Circuit

Table 19: Network Status Indications of WWAN_LED#

WWAN_LED# Logic Level	Description
Low Level (LED On)	RF function is enabled.
High Level (LED Off)	RF function is disabled if any of the following occurs: <ul style="list-style-type: none"> ● The (U)SIM card is not powered. ● W_DISABLE1# is at low level (airplane mode enabled). ● AT+CFUN=4 and AT+CFUN=0 (RF function disabled).

4.4.4. WAKE_ON_WAN#

The WAKE_ON_WAN# is an open drain pin, which requires a pull-up resistor on the host. When a URC returns, a 1 s low level pulse signal will be outputted to wake up the host.

Table 20: State of the WAKE_ON_WAN#

WAKE_ON_WAN# State	Module Operation Status
Output a 1 s low level pulse signal	Call/SMS/Data is incoming (to wake up the host)

Always at high level

Idle/Sleep

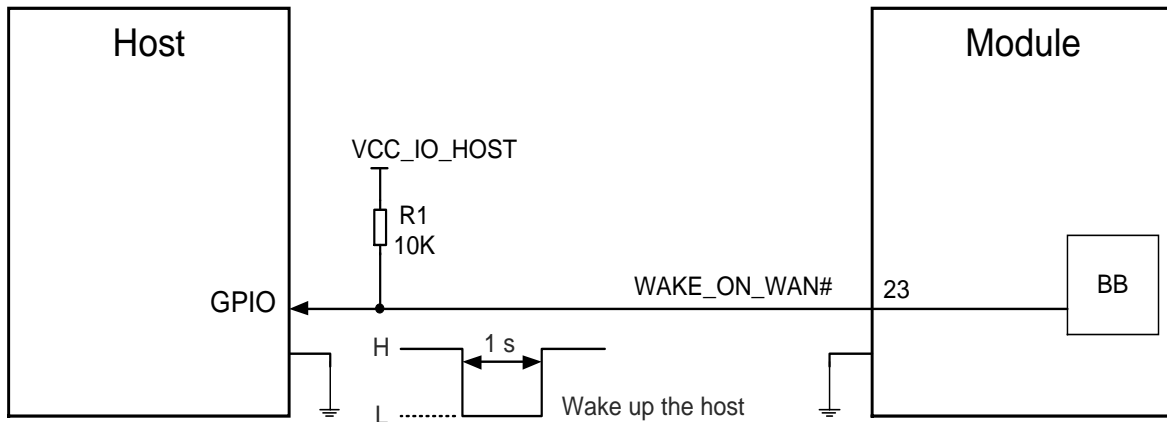

Figure 23: Reference Circuit of WAKE_ON_WAN#

NOTE

The voltage level on VCC_IO_HOST depends on the host side due to the open drain in pin 23 of the module.

4.4.5. DPR

The module provides a DPR (Dynamic Power Reduction) pin for body SAR (Specific Absorption Rate) detection. The signal is sent from a host system proximity sensor to the module to provide an input trigger, which will reduce the output power in burst transmission.

Table 21: Pin definition of DPR

Pin No.	Pin Name	I/O	Description	Comment
25	DPR	DI, PU	Dynamic power reduction	High level by default. Active low.

Table 22: Function of the DPR Signal

DPR Logic Level	Function
High/Floating	No backoff of max transmitting power occurred

Low	Backoff of max transmitting power occurred according to configuration in SAR_efs file
-----	---

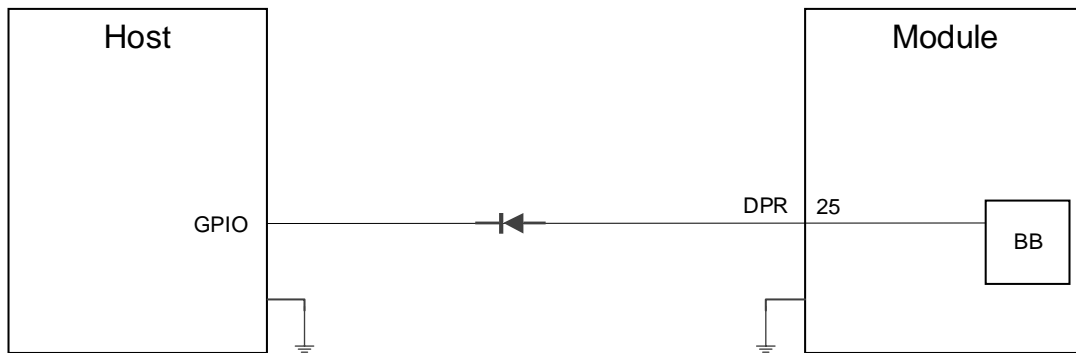

NOTE: DPR pin is 1.8 V power domain. Host's GPIO could be a 1.8 V or 3.3 V voltage level.

Figure 24: Reference Design of DPR

4.4.6. WLAN_PA_EN

QLN enables self-protection circuit (integrated inside QLN) when WLAN_PA_EN is at high level.

- In LTE mode, WLAN_PA_EN is set to 0 (low level) by default.
- When WLAN_PA_EN is set to 1 (high level), the LNA will be in self-protection mode.

Table 23: Pin definition of WLAN_PA_EN

Pin No.	Pin Name	I/O	Description	Comment
60	WLAN_PA_EN	DI, PD	Self-protection of QLN control	1.8 V power domain; It is not connected for EM060K-NA and EM060K-EA.

4.5. Cellular/WLAN COEX Interface*

The module provides a cellular/WLAN coexistence interface. The following table shows the pin definition of this interface.

Table 24: Pin Definition of Cellular/WLAN COEX Interface

Pin No.	Pin Name	I/O	Description	Comment
62	COEX_RXD	DI, PD	LTE/WLAN coexistence receive	1.8 V
64	COEX_TXD	DO, PD	LTE/WLAN coexistence transmit	1.8 V

4.6. Configuration Pins

Table 25: List of Configuration Pins

Config_0 (Pin 21)	Config_1 (Pin 69)	Config_2 (Pin 75)	Config_3 (Pin 1)	Module Type and Main Host Interface	Port Configuration
GND	GND	NC	NC	WWAN–USB3.0	2

Table 26: Pin Definition of Configuration Pins

Pin No.	Pin Name	I/O	Description
21	CONFIG_0	DO	Connected to GND internally
69	CONFIG_1	DO	Connected to GND internally
75	CONFIG_2	DO	Not connected internally
1	CONFIG_3	DO	Not connected internally

The following figure shows a reference circuit for these four pins.

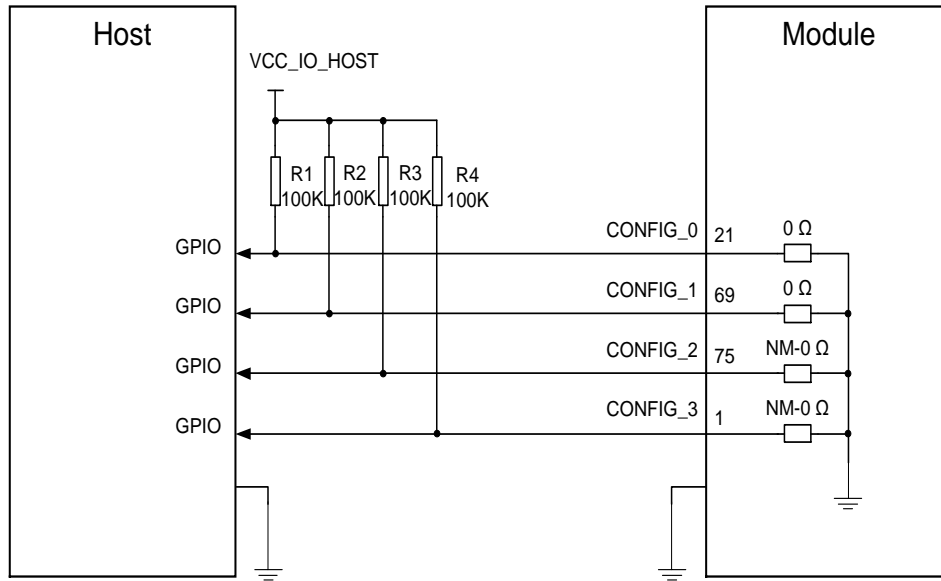

Figure 25: Recommended Circuit of Configuration Pins

NOTE

The voltage level VCC_IO_HOST depends on the host side, and could be a 1.8 V or 3.3 V voltage level.

4.7. PCIe Interface

The module provides one integrated PCIe (Peripheral Component Interconnect Express) interface which can transmit data. The module supports PCIe Root Complex (RC) mode only.

- Compliant with *PCI Express Base Specification Revision 2.0*
- Data rate up to 5 Gbps/lane
- Can be connected to external WLAN IC
- RC mode only

Table 27: Pin Definition of the PCIe Interface

Pin Name	Pin No.	I/O	Description	Comment
PCIE_REFCLK_M	53	AO	PCIe reference clock (-)	Require differential impedance of 95 Ω.
PCIE_REFCLK_P	55	AO	PCIe reference clock (+)	If unused, keep them

PCIE_TX_M	41	AO	PCIe transmit (-)	unconnected.
PCIE_TX_P	43	AO	PCIe transmit (+)	
PCIE_RX_M	47	AI	PCIe receive (-)	
PCIE_RX_P	49	AI	PCIe receive (+)	
CLKREQ	52	DI	PCIe clock request	If unused, keep it unconnected.
PERST#	50	DO	PCIe reset	If unused, keep it unconnected. RC mode only.
PEWAKE#	54	DI	PCIe wake up	If unused, keep it open.

4.7.1. Root Complex Mode

In this mode, the module works as a PCIe RC device. The following figure shows a reference circuit of PCIe RC mode.

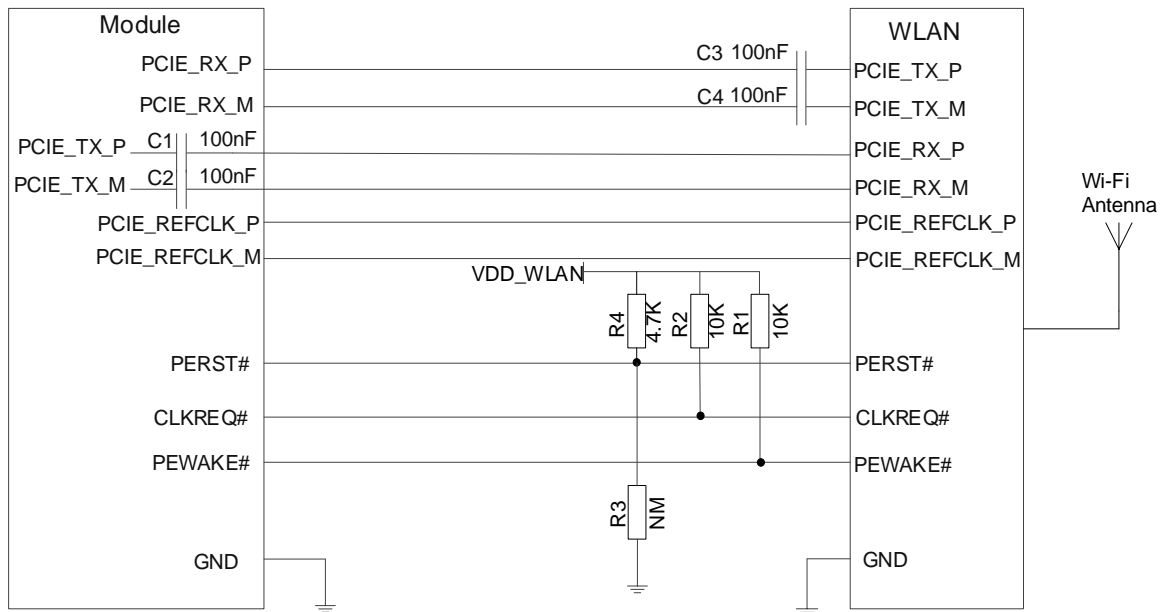

Figure 26: Reference Circuit of PCIe Interface (RC Mode)

To enhance the reliability and availability in applications, follow the criteria below in the PCIe interface circuit design:

- Keep the PCIe data and control signals away from sensitive circuits and signals, such as RF, USB, and clock signals.
- Add a capacitor in series on Rx traces to prevent any DC bias.

- Keep the maximum trace length less than 300 mm.
- Keep the length matching of each differential data pair (Tx/Rx/REFCLK) less than 0.7 mm for PCIe routing traces.
- Keep the differential impedance of PCIe data trace as $95 \Omega \pm 10 \%$.
- Do not route PCIe data traces under components or cross them with other traces.

Table 28: PCIe Trace Length Inside the Module

Pin No.	Pin Name	Length (mm)	Length Difference (mm)
53	PCIE_REFCLK_M	20.83	0.24
55	PCIE_REFCLK_P	20.59	
41	PCIE_TX_M	21.26	0.32
43	PCIE_TX_P	21.58	
47	PCIE_RX_M	20.16	0.31
49	PCIE_RX_P	19.85	

5 Antenna Interfaces

Appropriate antenna type and design should be used with matched antenna parameters according to specific application. It is required to perform a comprehensive functional test for the RF design before mass production of terminal products. The entire content of this chapter is provided for illustration only. Analysis, evaluation and determination are still necessary when designing target products.

5.1. Cellular Network

5.1.1. Antenna Interfaces & Frequency Bands

The module provides a main antenna connector and a diversity/GNSS antenna connector, which are used to resist the fall of signals caused by high-speed movement and multipath effect. The impedance of antenna ports is 50 Ω.

Table 29: Antenna Connectors Definition for EM060K-GL & EM120K-GL

Antenna Connector	I/O	Description	Comment
ANT_MAIN	AIO	Main antenna interface: <ul style="list-style-type: none"> ● LTE: TRx ● WCDMA: TRx 	
ANT_DRx/GNSS	AI	Diversity/GNSS antenna interface: <ul style="list-style-type: none"> ● LTE: DRx ● WCDMA: DRx ● GNSS: GPS/GLONASS/Galileo/BDS 	50 Ω impedance

Table 30: Antenna Connectors Definition for EM060K-NA

Antenna Connector	I/O	Description	Comment
ANT_MAIN	AIO	Main antenna interface: <ul style="list-style-type: none"> ● LTE: TRx 	50 Ω impedance
ANT_DRx	AI	Diversity antenna interface: <ul style="list-style-type: none"> ● LTE: DRx 	

ANT_GNSS	AI	GNSS antenna interface: ● GNSS: GPS/GLONASS/Galileo/BDS
----------	----	--

Table 31: Antenna Connectors Definition for EM060K-EA

Antenna Connector	I/O	Description	Comment
ANT_MAIN	AIO	Main antenna interface: ● LTE: TRx ● WCDMA: TRx	
ANT_DRx	AI	Diversity antenna interface: ● LTE: DRx ● WCDMA: DRx	50 Ω impedance
ANT_GNSS	AI	GNSS antenna interface: ● GNSS: GPS/GLONASS/Galileo/BDS	

Table 32: Frequency Bands for EM060K-GL & EM120K-GL

3GPP Band	Transmit	Receive	Unit
WCDMA B1	1920–1980	2110–2170	MHz
WCDMA B2	1850–1910	1930–1990	MHz
WCDMA B3	1710–1785	1805–1880	MHz
WCDMA B4	1710–1755	2110–2155	MHz
WCDMA B5	824–849	869–894	MHz
WCDMA B6	830–840	875–885	MHz
WCDMA B8	880–915	925–960	MHz
WCDMA B19	830–845	875–890	MHz
LTE-FDD B1	1920–1980	2110–2170	MHz
LTE-FDD B2	1850–1910	1930–1990	MHz
LTE-FDD B3	1710–1785	1805–1880	MHz
LTE-FDD B4	1710–1755	2110–2155	MHz
LTE-FDD B5	824–849	869–894	MHz

LTE-FDD B7	2500–2570	2620–2690	MHz
LTE-FDD B8	880–915	925–960	MHz
LTE-FDD B12	699–716	729–746	MHz
LTE-FDD B13	777–787	746–756	MHz
LTE-FDD B14	788–798	758–768	MHz
LTE-FDD B17	704–716	734–746	MHz
LTE-FDD B18	815–830	860–875	MHz
LTE-FDD B19	830–845	875–890	MHz
LTE-FDD B20	832–862	791–821	MHz
LTE-FDD B25	1850–1915	1930–1995	MHz
LTE-FDD B26	814–849	859–894	MHz
LTE-FDD B28	703–748	758–803	MHz
LTE-FDD B29 ³	-	717–728	MHz
LTE-FDD B30	2305–2315	2350–2360	MHz
LTE-FDD B32 ⁸	-	1452–1496	MHz
LTE-FDD B66	1710–1780	2110–2200	MHz
LTE-FDD B71	663-698	617-652	MHz
LTE-TDD B34	2010-2025	2010-2025	MHz
LTE-TDD B38	2570–2620	2570–2620	MHz
LTE-TDD B39	1880–1920	1880–1920	MHz
LTE-TDD B40	2300–2400	2300–2400	MHz
LTE-TDD B41	2496–2690	2496–2690	MHz
LTE-TDD B42	3400–3600	3400–3600	MHz
LTE-TDD B43	3600–3800	3600–3800	MHz
LTE-TDD B46 ⁸	-	5150–5925	MHz

LTE-TDD B48	3550–3700	3550–3700	MHz
-------------	-----------	-----------	-----

Table 33: Frequency Bands for EM060K-NA

3GPP Band	Transmit	Receive	Unit
LTE-FDD B2	1850–1910	1930–1990	MHz
LTE-FDD B4	1710–1755	2110–2155	MHz
LTE-FDD B5	824–849	869–894	MHz
LTE-FDD B7	2500–2570	2620–2690	MHz
LTE-FDD B12	699–716	729–746	MHz
LTE-FDD B13	777–787	746–756	MHz
LTE-FDD B14	788–798	758–768	MHz
LTE-FDD B17	704–716	734–746	MHz
LTE-FDD B25	1850–1915	1930–1995	MHz
LTE-FDD B26	814–849	859–894	MHz
LTE-FDD B29 ¹⁰	-	717–728	MHz
LTE-FDD B30	2305–2315	2350–2360	MHz
LTE-FDD B66	1710–1780	2110–2200	MHz
LTE-FDD B71	663-698	617-652	MHz
LTE-TDD B41	2496–2690	2496–2690	MHz
LTE-TDD B42	3400–3600	3400–3600	MHz
LTE-TDD B43	3600–3800	3600–3800	MHz
LTE-TDD B48	3550–3700	3550–3700	MHz

¹⁰ LTE-FDD B29/B32 and LTE-TDD B46 support Rx only and are only for secondary component carrier.

Table 34: Frequency Bands for EM060K-EA

3GPP Band	Transmit	Receive	Unit
WCDMA B1	1920–1980	2110–2170	MHz
WCDMA B3	1710–1785	1805–1880	MHz
WCDMA B5	824–849	869–894	MHz
WCDMA B8	880–915	925–960	MHz
LTE-FDD B1	1920–1980	2110–2170	MHz
LTE-FDD B3	1710–1785	1805–1880	MHz
LTE-FDD B5	824–849	869–894	MHz
LTE-FDD B7	2500–2570	2620–2690	MHz
LTE-FDD B8	880–915	925–960	MHz
LTE-FDD B20	832–862	791–821	MHz
LTE-FDD B28	703–748	758–803	MHz
LTE-FDD B32 ⁸	-	1452–1496	MHz
LTE-TDD B38	2570–2620	2570–2620	MHz
LTE-TDD B40	2300–2400	2300–2400	MHz
LTE-TDD B41	2496–2690	2496–2690	MHz

5.1.2. Antenna Tuner Control Interface*

ANTCTL[0:3] and RFFE interfaces are used for antenna tuner control and should be routed to an appropriate antenna control circuit.

5.1.2.1. Antenna Tuner Control Interface through GPIOs

Table 35: Pin Definition of Antenna Tuner Control Interface through GPIOs

Pin No.	Pin Name	I/O	Description	Comment
---------	----------	-----	-------------	---------

59	ANTCTL0	DO, PD		1.8 V
61	ANTCTL1	DO, PD	Antenna tuner GPIO control	1.8 V
63	ANTCTL2	DO, PD		1.8 V
65	ANTCTL3	DO, PD		1.8 V

5.1.2.2. Antenna Tuner Control Interface through RFFE

Table 36: Pin Definition of Antenna Tuner Control Interface through RFFE

Pin No.	Pin Name	I/O	Description	Comment
56	RFFE_CLK	DO, PD	Used for external MIPI IC control	1.8 V
58	RFFE_DATA	DIO, PD	Used for external MIPI IC control	1.8 V

NOTE

If RFFE_CLK and RFFE_DATA are required, please contact Quectel for more details.

5.1.3. Tx Power

Table 37: EM060K-GL , EM120K-GL and EM060K-EA Tx Power

Frequency Band	Modulation	Max.	Min.	Comment
WCDMA	BPSK	23 dBm ±2 dB	< -50 dBm	-
LTE-FDD	QPSK	23 dBm ±2 dB	< -40 dBm	10 MHz, 1RB
LTE-TDD	QPSK	23 dBm ±2 dB	< -40 dBm	10 MHz, 1RB

Table 38: EM060K-NA Tx Power

Frequency Band	Modulation	Max.	Min.	Comment
LTE-FDD	QPSK	23 dBm ±2 dB	< -40 dBm	10 MHz, 1RB

LTE-TDD	QPSK	23 dBm ±2 dB	< -40 dBm	10 MHz, 1RB
---------	------	--------------	-----------	-------------

5.1.4. Rx Sensitivity

Table 39: EM060K-GL Rx Sensitivity

Frequency Band	Primary	Diversity	SIMO ¹¹	3GPP (SIMO) (dBm)	Comment ¹²
WCDMA B1	-108.5	-109.5	-111.5	-106.7	
WCDMA B2	-108.5	-109.5	-111.5	-104.7	
WCDMA B3	-109	-109	-111.5	-103.7	
WCDMA B4	-108	-108.5	-111	-106.7	
WCDMA B5	-110.5	-111	-113	-104.7	
WCDMA B6	-110.5	-111	-113	-106.7	
WCDMA B8	-111	-111.5	-113.5	-103.7	
WCDMA B19	-110.5	-111	-113	-106.7	
LTE-FDD B1	-96.5	-98	-100	-96.3	10 MHz
LTE-FDD B2	-97	-97.5	-100	-94.3	10 MHz
LTE-FDD B3	-98	-97.5	-100.5	-93.3	10 MHz
LTE-FDD B4	-97	-97	-99.5	-96.3	10 MHz
LTE-FDD B5	-99	-99	-101.5	-94.3	10 MHz
LTE-FDD B7	-96.5	-97.5	-99.5	-94.3	10 MHz
LTE-FDD B8	-99	-99	-101.5	-93.3	10 MHz
LTE-FDD B12	-98.5	-99.5	-101.5	-93.3	10 MHz
LTE-FDD B13	-99	-99.5	-101.5	-93.3	10 MHz
LTE-FDD B14	-99	-99.5	-101.5	-93.3	10 MHz

¹¹ SIMO is a smart antenna technology that uses a single antenna at the transmitter side and multiple antennas at the receiver side, which can improve Rx performance.

¹² The RB configuration follows 3GPP specification.

LTE-FDD B17	-98.5	-99.5	-101.5	-93.3	10 MHz
LTE-FDD B18	-98.5	-99	-101.5	-96.3	10 MHz
LTE-FDD B19	-98.5	-99	-101.5	-96.3	10 MHz
LTE-FDD B20	-99	-98	-101	-93.3	10 MHz
LTE-FDD B25	-97	-97.5	-100	-92.8	10 MHz
LTE-FDD B26	-98.5	-99	-101.5	-93.8	10 MHz
LTE-FDD B28	-99.5	-99.5	-102	-94.8	10 MHz
LTE-FDD B29 ¹³	-98.5	-98.5	-101	-93.3	10 MHz
LTE-FDD B30	-95	-96.5	-98.5	-95.3	10 MHz
LTE-FDD B32 ¹³	-98	-96.5	-99.5	-96.3	10 MHz
LTE-FDD B66	-97	-97	-99.5	-95.8	10 MHz
LTE-FDD B71	-99	-98.5	-101.5	-94.3	10 MHz
LTE-TDD B34	-97.5	-98	-100	-96.3	10 MHz
LTE-TDD B38	-97.5	-97.5	-99.5	-96.3	10 MHz
LTE-TDD B39	-97.5	-97	-99.5	-96.3	10 MHz
LTE-TDD B40	-95.5	-95.5	-98.5	-96.3	10 MHz
LTE-TDD B41	-97	-97	-99.5	-94.3	10 MHz
LTE-TDD B42	-97.5	-98.5	-100.5	-95.0	10 MHz
LTE-TDD B43	-97.5	-98.5	-100.5	-95.0	10 MHz
LTE-TDD B46 ¹³	-93	-92	-95.5	-88.5	20 MHz
LTE-TDD B48	-97.5	-98	-100.5	-95.0	10 MHz

¹³ The test results are based on CA_2A-29A, CA_20A-32A and CA_46A-66A. LTE-FDD B29/B32 and LTE-TDD B46 support Rx only and are only for secondary component carrier.

Table 40: EM120K-GL Rx Sensitivity

Frequency Band	Primary	Diversity	SIMO ¹¹	3GPP (SIMO) (dBm)	Comment ¹²
WCDMA B1	-108.5	-109.5	-111.5	-106.7	
WCDMA B2	-108.5	-109.5	-111.5	-104.7	
WCDMA B3	-109	-109	-111.5	-103.7	
WCDMA B4	-108	-108.5	-111	-106.7	
WCDMA B5	-110.5	-111	-113	-104.7	
WCDMA B6	-110.5	-111	-113	-106.7	
WCDMA B8	-111	-111.5	-113.5	-103.7	
WCDMA B19	-110.5	-111	-113	-106.7	
LTE-FDD B1	-96.5	-98	-100	-96.3	10 MHz
LTE-FDD B2	-97	-97.5	-100	-94.3	10 MHz
LTE-FDD B3	-98	-97.5	-100.5	-93.3	10 MHz
LTE-FDD B4	-97	-97	-99.5	-96.3	10 MHz
LTE-FDD B5	-99	-99	-101.5	-94.3	10 MHz
LTE-FDD B7	-96.5	-97.5	-99.5	-94.3	10 MHz
LTE-FDD B8	-99	-99	-101.5	-93.3	10 MHz
LTE-FDD B12	-98.5	-99.5	-101.5	-93.3	10 MHz
LTE-FDD B13	-99	-99.5	-101.5	-93.3	10 MHz
LTE-FDD B14	-99	-99.5	-101.5	-93.3	10 MHz
LTE-FDD B17	-98.5	-99.5	-101.5	-93.3	10 MHz
LTE-FDD B18	-98.5	-99	-101.5	-96.3	10 MHz
LTE-FDD B19	-98.5	-99	-101.5	-96.3	10 MHz
LTE-FDD B20	-99	-98	-101	-93.3	10 MHz

LTE-FDD B25	-97	-97.5	-100	-92.8	10 MHz
LTE-FDD B26	-98.5	-99	-101.5	-93.8	10 MHz
LTE-FDD B28	-99.5	-99.5	-102	-94.8	10 MHz
LTE-FDD B29 ¹³	-98.5	-98.5	-101	-93.3	10 MHz
LTE-FDD B30	-95	-96.5	-98.5	-95.3	10 MHz
LTE-FDD B32 ¹³	-98	-96.5	-99.5	-96.3	10 MHz
LTE-FDD B66	-97	-97	-99.5	-95.8	10 MHz
LTE-FDD B71	-99	-98.5	-101.5	-94.3	10 MHz
LTE-TDD B34	-97.5	-98	-100	-96.3	10 MHz
LTE-TDD B38	-97.5	-97.5	-99.5	-96.3	10 MHz
LTE-TDD B39	-97.5	-97	-99.5	-96.3	10 MHz
LTE-TDD B40	-95.5	-95.5	-98.5	-96.3	10 MHz
LTE-TDD B41	-97	-97	-99.5	-94.3	10 MHz
LTE-TDD B42	-97.5	-98.5	-100.5	-95.0	10 MHz
LTE-TDD B43	-97.5	-98.5	-100.5	-95.0	10 MHz
LTE-TDD B46 ¹³	-93	-92	-95	-88.5	20 MHz
LTE-TDD B48	-97.5	-98	-100.5	-95.0	10 MHz

Table 41: EM060K-NA Rx Sensitivity

Frequency Bands	Primary	Diversity	SIMO ¹¹	3GPP (SIMO) (dBm)	Comment ¹²
LTE-FDD B2	-99.5	-99.4	-102	-94.3	10 MHz
LTE-FDD B4	-99	-98.3	-101.1	-96.3	10 MHz
LTE-FDD B5	-99.5	-99.4	-102	-94.3	10 MHz
LTE-FDD B7	-97	-97.2	-100	-94.3	10 MHz
LTE-FDD B12	-99.3	-100.3	-102.4	-93.3	10 MHz

LTE-FDD B13	-99.2	-100.5	-102.6	-93.3	10 MHz
LTE-FDD B14	-99	-100.3	-102.3	-93.3	10 MHz
LTE-FDD B17	-99.2	-100.3	-102.5	-93.3	10 MHz
LTE-FDD B25	-99.4	-99.2	-101.9	-92.8	10 MHz
LTE-FDD B26	-99.2	-99.4	-101.9	-93.8	10 MHz
LTE-FDD B29 ¹³	-98.5	-99	-102	-93.3	10 MHz
LTE-FDD B30	-96.8	-97.7	-99.4	-95.3	10MHz
LTE-FDD B66	-99	-97.8	-100.9	-95.8	10 MHz
LTE-FDD B71	-100	-100.3	-102.8	-94.3	10 MHz
LTE-TDD B41	-97	-98.2	-100.3	-94.3	10 MHz
LTE-TDD B42	-98.1	-99.9	-101.4	-95.0	10 MHz
LTE-TDD B43	-98.1	-100.1	-102	-95.0	10 MHz
LTE-TDD B48	-98.2	-100.2	-102.3	-95.0	10 MHz

Table 42: EM060K-EA Rx Sensitivity

Frequency Band	Primary	Diversity	SIMO ¹⁴	3GPP (SIMO) (dBm)	Comment ¹⁵
WCDMA B1	TBD	TBD	TBD	-106.7	
WCDMA B3	TBD	TBD	TBD	-103.7	
WCDMA B5	TBD	TBD	TBD	-104.7	
WCDMA B8	TBD	TBD	TBD	-103.7	
LTE-FDD B1	TBD	TBD	TBD	-96.3	10 MHz
LTE-FDD B3	TBD	TBD	TBD	-93.3	10 MHz
LTE-FDD B5	TBD	TBD	TBD	-94.3	10 MHz
LTE-FDD B7	TBD	TBD	TBD	-94.3	10 MHz

¹⁴ SIMO is a smart antenna technology that uses a single antenna at the transmitter side and multiple antennas at the receiver side, which can improve Rx performance.

¹⁵ The RB configuration follows 3GPP specification.

LTE-FDD B8	TBD	TBD	TBD	-93.3	10 MHz
LTE-FDD B20	TBD	TBD	TBD	-93.3	10 MHz
LTE-FDD B28	TBD	TBD	TBD	-94.8	10 MHz
LTE-FDD B32 ¹³	TBD	TBD	TBD	-96.3	10 MHz
LTE-TDD B38	TBD	TBD	TBD	-96.3	10 MHz
LTE-TDD B40	TBD	TBD	TBD	-96.3	10 MHz
LTE-TDD B41	TBD	TBD	TBD	-94.3	10 MHz

5.2. GNSS

5.2.1. Antenna Interface & Frequency Bands

The module includes a fully integrated global navigation satellite system solution.

The module supports standard NMEA 0183 protocol, and outputs NMEA sentences at 1 Hz data update rate via USB interface by default.

By default, the module GNSS engine is switched off. It has to be switched on via AT command. For more details, see **document [4]**.

Table 43: GNSS Frequency

Type	Frequency	Unit
GPS/Galileo	1575.42 ±1.023	MHz
GLONASS	1601.65 ±4.15	MHz
BDS	1561.098 ±2.046	MHz

5.2.2. GNSS Performance

Table 44: GNSS Performance

Parameter	Description	Condition	Typ.	Unit
-----------	-------------	-----------	------	------

Sensitivity	Acquisition	Autonomous	-146	dBm
	Reacquisition	Autonomous	-158	dBm
	Tracking	Autonomous	-158	dBm
TTFF	Cold start @ open sky	Autonomous	35	s
		XTRA enabled	13	s
	Warm start @ open sky	Autonomous	23	s
		XTRA enabled	3	s
	Hot start @ open sky	Autonomous	2	s
		XTRA enabled	2	s
Accuracy	CEP-50	Autonomous @ open sky	2	m

NOTE

1. Tracking sensitivity: the minimum GNSS signal power at which the module can maintain lock (keep positioning for at least 3 minutes continuously).
2. Reacquisition sensitivity: the minimum GNSS signal power required for the module to maintain lock within 3 minutes after loss of lock.
3. Acquisition sensitivity: the minimum GNSS signal power at which the module can fix position successfully within 3 minutes after executing cold start command.

5.3. Antenna Design Requirements

Table 45: Antenna Requirements

Type	Requirements
Main Antenna (Tx/Rx)	<ul style="list-style-type: none"> ● VSWR: ≤ 2 ● Efficiency: >30 %
Diversity Antenna (RX)	<ul style="list-style-type: none"> ● Max Input Power: 50 W ● Input Impedance: 50 Ω ● Cable Insertion Loss:
Diversity/GNSS Antenna	<ul style="list-style-type: none"> - < 1 dB: LB (<1 GHz) - < 1.5 dB: MB (1–2.3 GHz) - < 2 dB: LB (> 2.3 GHz)

NOTE

It is recommended to use a passive GNSS antenna when LTE B13 or B14 is supported, as the use of active antenna may generate harmonics which will affect the GNSS performance.

5.4. Antenna Connectors

5.4.1. Antenna Connector Location

The antenna connector locations are shown below.

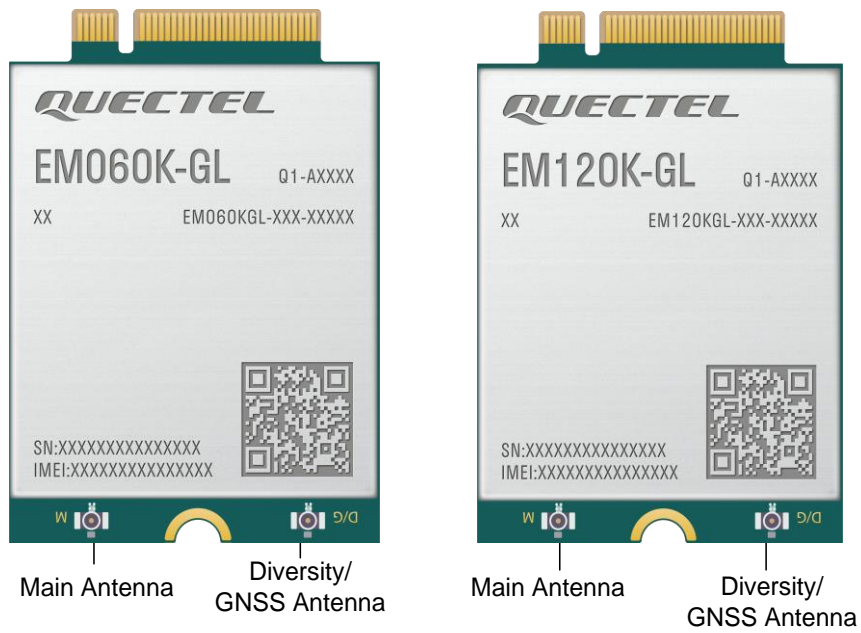

Figure 27: Antenna Connectors on EM060K-GL & EM120K-GL



Figure 28: Antenna Connectors on EM060K-NA



Figure 29: Antenna Connectors on EM060K-EA

NOTE

The antennas from left to right are respectively main antenna, diversity antenna and GNSS Antenna.

5.4.2. Antenna Connector Specifications

The modules are mounted with standard 2 mm × 2 mm receptacle antenna connectors for convenient antenna connection. The connector dimensions are illustrated as below:

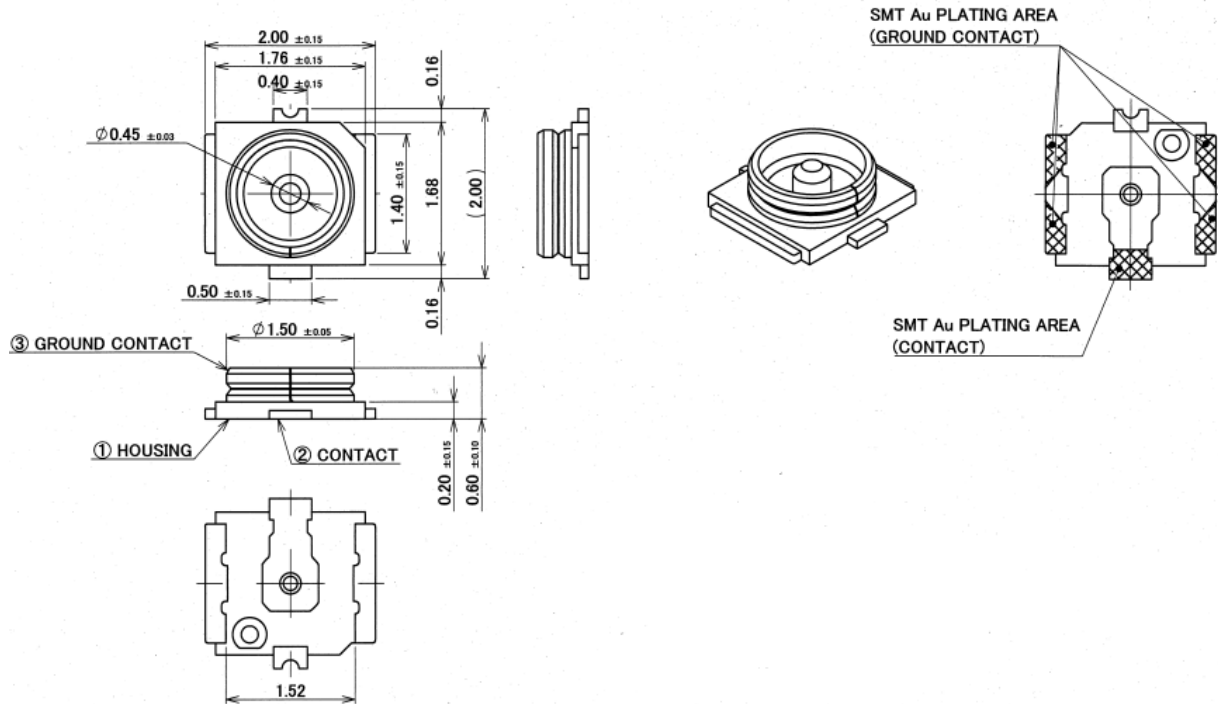

Figure 30: Dimensions of the Receptacle (Unit: mm)

Table 46: Major Specifications of the RF Connectors

Item	Specification
Nominal Frequency Range	DC to 6 GHz
Nominal Impedance	50 Ω
Temperature Rating	-40 to +85 °C
Voltage Standing Wave Ratio (VSWR)	Meet the requirements of: Max. 1.3 (DC–3 GHz) Max. 1.45 (3–6 GHz)

5.4.3. Antenna Connector Installation

The receptacle RF connector used in conjunction with the modules will accept two types of mated plugs that will meet a maximum height of 1.2 mm using a Ø 0.81 mm coaxial cable or a maximum height of 1.45 mm utilizing a Ø 1.13 mm coaxial cable.

The following figure shows the dimensions of mated plugs using Ø 0.81 mm coaxial cables:

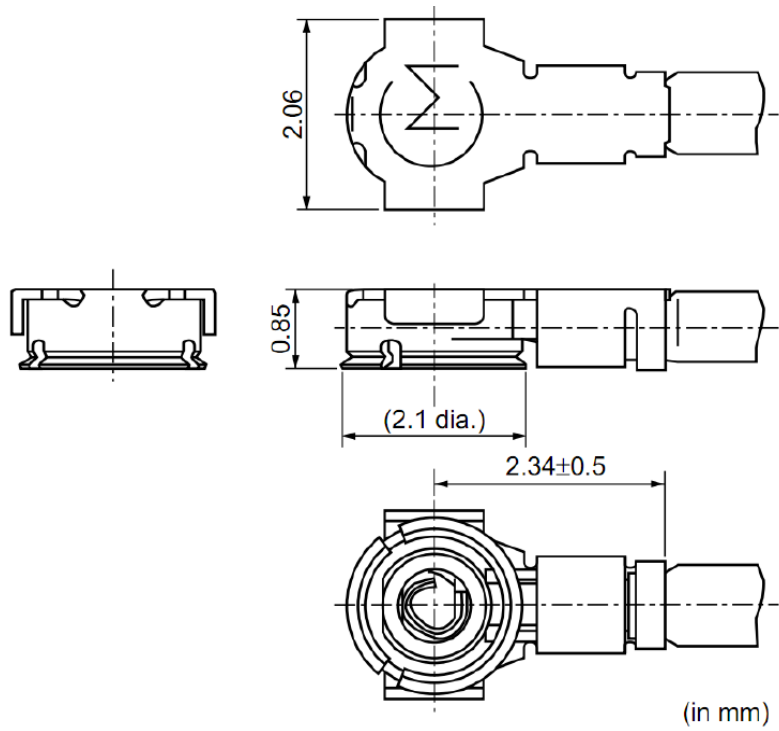

Figure 31: Dimensions of Mated Plugs (Ø0.81/Ø1.13 mm Coaxial Cables) (Unit: mm)

The following figure illustrates the connection between the receptacle RF connector on the modules and the mated plugs using a Ø 0.81 mm coaxial cable.

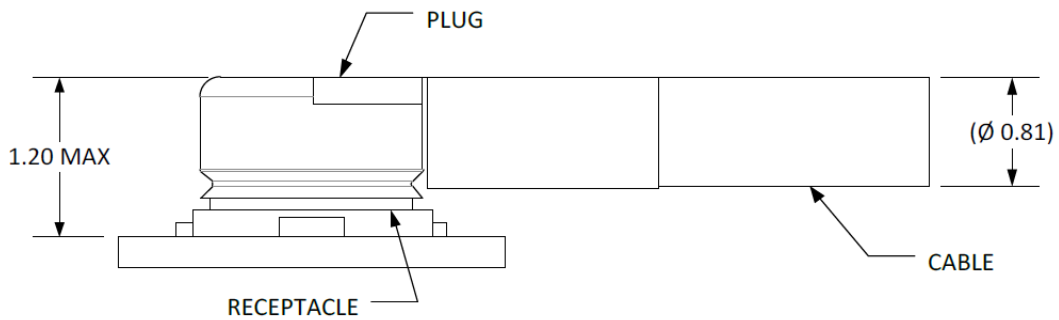

Figure 32: Space Factor of Mated Connectors (Ø0.81 mm Coaxial Cables) (Unit: mm)

The following figure illustrates the connection between the receptacle RF connector on EM060K-GL and EM120K-GL and the mated plugs using a Ø 1.13 mm coaxial cable.

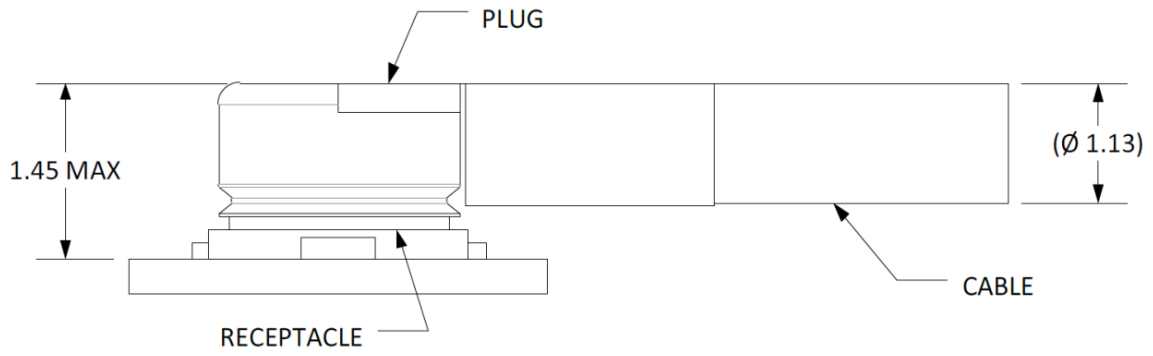

Figure 33: Space Factor of Mated Connectors (Ø 1.13 mm Coaxial Cables) (Unit: mm)

6 Electrical Characteristics and Reliability

6.1. Absolute Maximum Ratings

Absolute maximum ratings for power supply and voltage on digital and analog pins of the modules are listed in the following table.

Table 47: Absolute Maximum Ratings

Parameter	Min.	Typ.	Max.	Unit
VCC	-0.3	-	4.7	V

6.2. Power Supply Ratings

The typical input voltage of the module is 3.7 V.

Table 48: Power Supply Requirements

Parameter	Description	Condition	Min.	Typ.	Max.	Unit
VCC	Power supply for the module	The actual input voltages must be kept between the minimum and maximum values.	3.135	3.7	4.4	V
Voltage Ripple	-		-	30	100	mV

6.3. Power Consumption

Table 49: EM060K-GL Power Consumption (3.7 V Power Supply)

Description	Condition	Typ.	Unit
OFF state	Power down	70	μA
Sleep State	AT+CFUN=0 @ USB2.0 Suspend	1.65	mA
	AT+CFUN=0 @ USB3.0 Suspend	1.67	mA
	AT+CFUN=4 @ USB2.0 Suspend	1.66	mA
	AT+CFUN=4 @ USB3.0 Suspend	1.88	mA
	WCDMA PF = 64 @ USB2.0 Suspend	3.09	mA
	WCDMA PF = 64 @ USB3.0 Suspend	3.01	mA
	LTE-FDD PF = 64 @ USB2.0 Suspend	3.3	mA
	LTE-FDD PF = 64 @ USB3.0 Suspend	3.3	mA
	LTE-TDD PF = 64 @ USB2.0 Suspend	3.44	mA
	LTE-TDD PF = 64 @ USB3.0 Suspend	3.47	mA
	WCDMA PF = 64 (USB Disconnect)	19.18	mA
	WCDMA PF = 64 (USB2.0 Connect)	20.07	mA
	WCDMA PF = 64 (USB3.0 Connect)	38	mA
	LTE-FDD PF = 64 (USB Disconnect)	19.47	mA
Idle State	LTE-FDD PF = 64 (USB2.0 Connect)	21.22	mA
	LTE-FDD PF = 64 (USB3.0 Connect)	38	mA
	LTE-TDD PF = 64 (USB Disconnect)	19.5	mA
	LTE-TDD PF = 64 (USB2.0 Connect)	21.37	mA
	LTE-TDD PF = 64 (USB3.0 Connect)	38	mA
WCDMA Data	WCDMA B1 HSDPA CH10700 @ 22.2 dBm	620	mA

Transfer (GNSS Off)	WCDMA B1 HSUPA CH10700 @ 21 dBm	520	mA
	WCDMA B2 HSDPA CH9800 @ 22.1 dBm	550	mA
	WCDMA B2 HSUPA CH9800 @ 20.3 dBm	450	mA
	WCDMA B3 HSDPA CH1338 @ 22.2 dBm	590	mA
	WCDMA B3 HSUPA CH1338 @ 20 dBm	470	mA
	WCDMA B4 HSDPA CH1638 @ 22.1 dBm	560	mA
	WCDMA B4 HSUPA CH1638 @ 20.3 dBm	460	mA
	WCDMA B5 HSDPA CH4407 @ 22.2 dBm	590	mA
	WCDMA B5 HSUPA CH4407 @ 22.2 dBm	580	mA
	WCDMA B6 HSDPA CH4400 @ 22.2 dBm	570	mA
	WCDMA B6 HSUPA CH4400 @ 22.3 dBm	580	mA
	WCDMA B8 HSDPA CH3012 @ 22 dBm	550	mA
	WCDMA B8 HSUPA CH3012 @ 21.5 dBm	560	mA
	WCDMA B19 HSDPA CH738 @ 22 dBm	520	mA
	WCDMA B19 HSUPA CH738 @ 22.5 dBm	580	mA
LTE Data Transfer (GNSS Off)	LTE-FDD B1 CH300 @ 23.10 dBm	740	mA
	LTE-FDD B2 CH900 @ 23.16 dBm	690	mA
	LTE-FDD B3 CH1575 @ 23.13 dBm	700	mA
	LTE-FDD B4 CH2175 @ 23.05 dBm	682	mA
	LTE-FDD B5 CH2525 @ 23.13 dBm	690	mA
	LTE-FDD B7 CH3100 @ 23.22 dBm	900	mA
	LTE-FDD B8 CH3625 @ 23.12 dBm	660	mA
	LTE-FDD B12 CH5095 @ 23.07 dBm	650	mA
	LTE-FDD B13 CH5230 @ 23.11 dBm	585	mA
	LTE-FDD B14 CH5330 @ 23.12 dBm	540	mA

	LTE-FDD B17 CH5790 @ 23.05 dBm	565	mA
	LTE-FDD B18 CH5925 @ 23.14 dBm	590	mA
	LTE-FDD B19 CH6075 @ 23.18 dBm	610	mA
	LTE-FDD B20 CH6300 @ 23.17 dBm	575	mA
	LTE-FDD B25 CH8365 @ 23.21 dBm	700	mA
	LTE-FDD B26 CH8865 @ 23.14 dBm	710	mA
	LTE-FDD B28 CH9360 @ 22.95 dBm	615	mA
	LTE-FDD B30 CH9820 @ 23.03 dBm	1070	mA
	LTE-FDD B66 CH66886 @ 23.15 dBm	690	mA
	LTE-FDD B71 CH68786 @ 23.05 dBm	670	mA
	LTE-TDD B34 CH36275 @ 23.10 dBm	350	mA
	LTE-TDD B38 CH38000 @ 23.14 dBm	485	mA
	LTE-TDD B39 CH38450 @ 23.06 dBm	360	mA
	LTE-TDD B40 CH39150 @ 23.04 dBm	450	mA
	LTE-TDD B41 CH40740 @ 23.20 dBm	460	mA
	LTE-TDD B42 CH42590 @ 23.28 dBm	440	mA
	LTE-TDD B43 CH44590 @ 23.08 dBm	390	mA
	LTE-TDD B48 CH55990 @ 23.09 dBm	415	mA
	WCDMA B1 CH10700 @ 23.2 dBm	700	mA
	WCDMA B2 CH9800 @ 23.1 dBm	590	mA
	WCDMA B3 CH1338 @ 23.2 dBm	680	mA
WCDMA Voice* Call	WCDMA B4 CH1638 @ 23.1 dBm	630	mA
	WCDMA B5 CH4407 @ 23.2 dBm	660	mA
	WCDMA B6 CH4400 @ 23.2 dBm	660	mA
	WCDMA B8 CH3012 @ 23 dBm	610	mA

WCDMA B19 CH738 @ 23 dBm

620

mA

Table 50: EM060K-NA Power Consumption (3.7 V Power Supply)

Description	Condition	Typ.	Unit
OFF state	Power down	70	µA
Sleep State	AT+CFUN=0 @ USB2.0 Suspend	1.56	mA
	AT+CFUN=0 @ USB3.0 Suspend	1.58	mA
	AT+CFUN=4 @ USB2.0 Suspend	1.62	mA
	AT+CFUN=4 @ USB3.0 Suspend	1.63	mA
	LTE-FDD PF = 64 @ USB2.0 Suspend	3.06	mA
	LTE-FDD PF = 64 @ USB3.0 Suspend	3.11	mA
	LTE-TDD PF = 64 @ USB2.0 Suspend	3.2	mA
	LTE-TDD PF = 64 @ USB3.0 Suspend	3.31	mA
Idle State	LTE-FDD PF = 64 (USB Disconnect)	18.99	mA
	LTE-FDD PF = 64 (USB 2.0 Connect)	20.61	mA
	LTE-FDD PF = 64 (USB 3.0 Connect)	38	mA
	LTE-TDD PF = 64 (USB Disconnect)	18.85	mA
	LTE-TDD PF = 64 (USB 2.0 Connect)	20.87	mA
	LTE-TDD PF = 64 (USB 3.0 Connect)	38	mA
LTE Data Transfer (GNSS Off)	LTE-FDD B2 CH900 @ 23.25 dBm	591	mA
	LTE-FDD B4 CH2175 @ 22.99 dBm	562	mA
	LTE-FDD B5 CH2525 @ 23.33 dBm	584	mA
	LTE-FDD B7 CH3100 @ 23.3 dBm	800	mA
	LTE-FDD B12 CH5095 @ 23.29 dBm	623	mA
	LTE-FDD B13 CH5230 @ 23.22 dBm	611	mA

LTE-FDD B14 CH5330 @ 23.36 dBm	600	mA
LTE-FDD B17 CH5790 @ 23.16 dBm	600	mA
LTE-FDD B25 CH8365 @ 23.06 dBm	599	mA
LTE-FDD B26 CH8865 @ 23.35 dBm	659	mA
LTE-FDD B30 CH9820 @ 22.70 dBm	858	mA
LTE-FDD B66 CH66886 @ 23.12 dBm	610	mA
LTE-FDD B71 CH68786 @ 23.38 dBm	586	mA
LTE-TDD B41 CH40620 @ 23.6 dBm	407	mA
LTE-TDD B42 CH42590 @ 23.41 dBm	312	mA
LTE-TDD B43 CH44590 @ 23.27 dBm	365	mA
LTE-TDD B48 CH55990 @ 23.32 dBm	371	mA

Table 51: EM120K-GL Power Consumption (3.7 V Power Supply)

Description	Condition	Typ.	Unit
OFF state	Power down	70	μA
Sleep State	AT+CFUN=0 @ USB2.0 Suspend	1.71	mA
	AT+CFUN=0 @ USB3.0 Suspend	1.74	mA
	AT+CFUN=4 @ USB2.0 Suspend	1.78	mA
	AT+CFUN=4 @ USB3.0 Suspend	1.78	mA
	WCDMA PF = 64 @ USB2.0 Suspend	3.0	mA
	WCDMA PF = 64 @ USB3.0 Suspend	3.06	mA
	LTE-FDD PF = 64 @ USB2.0 Suspend	3.27	mA
	LTE-FDD PF = 64 @ USB3.0 Suspend	3.3	mA
	LTE-TDD PF = 64 @ USB2.0 Suspend	3.29	mA
	LTE-TDD PF = 64 @ USB3.0 Suspend	3.37	mA

Idle State	WCDMA PF = 64 (USB Disconnect)	18.72	mA
	WCDMA PF = 64 (USB2.0 Connect)	19.75	mA
	WCDMA PF = 64 (USB3.0 Connect)	38	mA
	LTE-FDD PF = 64 (USB Disconnect)	18.96	mA
	LTE-FDD PF = 64 (USB2.0 Connect)	20.85	mA
	LTE-FDD PF = 64 (USB3.0 Connect)	38	mA
	LTE-TDD PF = 64 (USB Disconnect)	19.11	mA
	LTE-TDD PF = 64 (USB2.0 Connect)	20.7	mA
	LTE-TDD PF = 64 (USB3.0 Connect)	38	mA
WCDMA Data Transfer (GNSS Off)	WCDMA B1 HSDPA CH10700 @ 22.2 dBm	620	mA
	WCDMA B1 HSUPA CH10700 @21 dBm	520	mA
	WCDMA B2 HSDPA CH9800 @ 22.1 dBm	550	mA
	WCDMA B2 HSUPA CH9800 @ 20.3 dBm	450	mA
	WCDMA B3 HSDPA CH1338 @ 22.2 dBm	590	mA
	WCDMA B3 HSUPA CH1338 @ 20 dBm	470	mA
	WCDMA B4 HSDPA CH1638 @ 22.1 dBm	560	mA
	WCDMA B4 HSUPA CH1638 @ 20.3 dBm	460	mA
	WCDMA B5 HSDPA CH4407 @ 22.2 dBm	590	mA
	WCDMA B5 HSUPA CH4407 @ 22.2 dBm	580	mA
	WCDMA B6 HSDPA CH4400 @ 22.2 dBm	570	mA
	WCDMA B6 HSUPA CH4400 @ 22.3 dBm	580	mA
	WCDMA B8 HSDPA CH3012 @ 22 dBm	550	mA
	WCDMA B8 HSUPA CH3012 @ 21.5 dBm	560	mA
	WCDMA B19 HSDPA CH738 @ 22 dBm	520	mA
WCDMA B19 HSUPA CH738 @ 22.5 dBm	580	mA	

LTE Data Transfer (GNSS Off)	LTE-FDD B1 CH300 @ 23.02 dBm	740	mA
	LTE-FDD B2 CH900 @ 23.1 dBm	690	mA
	LTE-FDD B3 CH1575 @ 23.13 dBm	700	mA
	LTE-FDD B4 CH2175 @ 23.06 dBm	682	mA
	LTE-FDD B5 CH2525 @ 23.13 dBm	690	mA
	LTE-FDD B7 CH3100 @ 23.03 dBm	900	mA
	LTE-FDD B8 CH3625 @ 23.15 dBm	660	mA
	LTE-FDD B12 CH5095 @ 23.03 dBm	650	mA
	LTE-FDD B13 CH5230 @ 23.10 dBm	585	mA
	LTE-FDD B14 CH5330 @ 22.95 dBm	540	mA
	LTE-FDD B17 CH5790 @ 23.05 dBm	565	mA
	LTE-FDD B18 CH5925 @ 23.16 dBm	600	mA
	LTE-FDD B19 CH6075 @ 23.17 dBm	620	mA
	LTE-FDD B20 CH6300 @ 23.17 dBm	581	mA
	LTE-FDD B25 CH8365 @ 23.35 dBm	700	mA
	LTE-FDD B26 CH8865 @ 23.15 dBm	710	mA
	LTE-FDD B28 CH9360 @ 23.05 dBm	615	mA
	LTE-FDD B30 CH9820 @ 23.24 dBm	1070	mA
	LTE-FDD B66 CH66886 @ 23.10 dBm	690	mA
	LTE-FDD B71 CH68786 @ 23.36 dBm	670	mA
LTE-TDD B34 CH36275 @ 23.11 dBm	350	mA	
LTE-TDD B38 CH38000 @ 23.13 dBm	485	mA	
LTE-TDD B39 CH38450 @ 23.05 dBm	360	mA	
LTE-TDD B40 CH39150 @ 23.21 dBm	460	mA	
LTE-TDD B41 CH40740 @ 23.09 dBm	460	mA	

	LTE-TDD B42 CH42590 @ 23.21 dBm	440	mA
	LTE-TDD B43 CH44590 @ 23.14 dBm	390	mA
	LTE-TDD B48 CH55990 @ 23.10 dBm	415	mA
WCDMA Voice* Call	WCDMA B1 CH10700 @23.2 dBm	700	mA
	WCDMA B2 CH9800 @ 23.1 dBm	590	mA
	WCDMA B3 CH1338 @ 23.2 dBm	680	mA
	WCDMA B4 CH1638 @ 23.1 dBm	630	mA
	WCDMA B5 CH4407 @ 23.2 dBm	660	mA
	WCDMA B6 CH4400 @ 23.2 dBm	660	mA
	WCDMA B8 CH3012 @ 23 dBm	610	mA
	WCDMA B19 CH738 @ 23 dBm	620	mA

Table 52: EM060K-EA Power Consumption (3.7 V Power Supply)

Description	Condition	Typ.	Unit
OFF state	Power down	TBD	μA
Sleep State	AT+CFUN=0 @ USB2.0 Suspend	TBD	mA
	AT+CFUN=0 @ USB3.0 Suspend	TBD	mA
	AT+CFUN=4 @ USB2.0 Suspend	TBD	mA
	AT+CFUN=4 @ USB3.0 Suspend	TBD	mA
	WCDMA PF = 64 @ USB2.0 Suspend	TBD	mA
	WCDMA PF = 64 @ USB3.0 Suspend	TBD	mA
	LTE-FDD PF = 64 @ USB2.0 Suspend	TBD	mA
	LTE-FDD PF = 64 @ USB3.0 Suspend	TBD	mA
	LTE-TDD PF = 64 @ USB2.0 Suspend	TBD	mA
	LTE-TDD PF = 64 @ USB3.0 Suspend	TBD	mA

Idle State	WCDMA PF = 64 (USB Disconnect)	TBD	mA
	WCDMA PF = 64 (USB2.0 Connect)	TBD	mA
	WCDMA PF = 64 (USB3.0 Connect)	TBD	mA
	LTE-FDD PF = 64 (USB Disconnect)	TBD	mA
	LTE-FDD PF = 64 (USB2.0 Connect)	TBD	mA
	LTE-FDD PF = 64 (USB3.0 Connect)	TBD	mA
	LTE-TDD PF = 64 (USB Disconnect)	TBD	mA
	LTE-TDD PF = 64 (USB2.0 Connect)	TBD	mA
	LTE-TDD PF = 64 (USB3.0 Connect)	TBD	mA
WCDMA Data Transfer (GNSS Off)	WCDMA B1 HSDPA CH10700 @ TBD dBm	TBD	mA
	WCDMA B1 HSUPA CH10700 @ TBD dBm	TBD	mA
	WCDMA B3 HSDPA CH1338 @ TBD dBm	TBD	mA
	WCDMA B3 HSUPA CH1338 @ TBD dBm	TBD	mA
	WCDMA B5 HSDPA CH4407 @ TBD dBm	TBD	mA
	WCDMA B5 HSUPA CH4407 @ TBD dBm	TBD	mA
	WCDMA B8 HSDPA CH3012 @ TBD dBm	TBD	mA
	WCDMA B8 HSUPA CH3012 @ TBD dBm	TBD	mA
LTE Data Transfer (GNSS Off)	LTE-FDD B1 CH300 @ TBD dBm	TBD	mA
	LTE-FDD B3 CH1575 @ TBD dBm	TBD	mA
	LTE-FDD B5 CH2525 @ TBD dBm	TBD	mA
	LTE-FDD B7 CH3100 @ TBD dBm	TBD	mA
	LTE-FDD B8 CH3625 @ TBD dBm	TBD	mA
	LTE-FDD B20 CH6300 @ TBD dBm	TBD	mA
	LTE-FDD B28 CH9360 @ TBD dBm	TBD	mA
LTE-TDD B38 CH38000 @ TBD dBm	TBD	mA	

	LTE-TDD B40 CH39150 @ TBD dBm	TBD	mA
	LTE-TDD B41 CH40620 @ TBD dBm	TBD	mA
	WCDMA B1 CH10700 @ TBD dBm	TBD	mA
WCDMA	WCDMA B3 CH1338 @ TBD dBm	TBD	mA
Voice* Call	WCDMA B5 CH4407 @ TBD dBm	TBD	mA
	WCDMA B8 CH3012 @ TBD dBm	TBD	mA

NOTE

1. Power consumption test is carried out under 3.7 V, 25 °C with 5G-M2 EVB, and with thermal dissipation measures.
2. For more details about current consumption, please contact Quectel Technical Support to obtain the power consumption test report of the modules.

6.4. Digital I/O Characteristics

Table 53: (U)SIM 1.8 V I/O Requirements

Parameter	Description	Min.	Max.	Unit
USIM_VDD	Power supply	1.65	1.95	V
V _{IH}	Input high voltage	0.7 × USIM_VDD	USIM_VDD + 0.3	V
V _{IL}	Input low voltage	-0.3	0.2 × USIM_VDD	V
V _{OH}	Output high voltage	0.8 × USIM_VDD	USIM_VDD	V
V _{OL}	Output low voltage	0	0.4	V

Table 54: (U)SIM 3.0 V I/O Requirements

Parameter	Description	Min.	Max.	Unit
USIM_VDD	Power supply	2.7	3.05	V

V _{IH}	High-level input voltage	0.7 × USIM_VDD	USIM_VDD + 0.3	V
V _{IL}	Low-level input voltage	-0.3	0.2 × USIM_VDD	V
V _{OH}	High-level output voltage	0.8 × USIM_VDD	USIM_VDD	V
V _{OL}	Low-level output voltage	0	0.4	V

Table 55: 1.8 V Digital I/O Requirements

Parameter	Description	Min.	Max.	Unit
V _{IH}	High-level input voltage	1.65	2.1	V
V _{IL}	Low-level input voltage	-0.3	0.54	V
V _{OH}	High-level output voltage	1.3	-	V
V _{OL}	Low-level output voltage	-	0.4	V

Table 56: 3.3 V Digital I/O Requirements

Parameter	Description	Min.	Max.	Unit
3.3 V	Power Domain	3.135	3.464	V
V _{IH}	Input high voltage	2.0	3.6	V
V _{IL}	Input low voltage	-0.5	0.8	V

6.5. ESD Protection

Static electricity occurs naturally and it may damage the module. Therefore, applying proper ESD countermeasures and handling methods is imperative. For example, wear anti-static gloves during the development, production, assembly and testing of the module; add ESD protection components to the ESD sensitive interfaces and points in the product design.

Table 57: Electrostatic Discharge Characteristics (Temperature: 25–30 °C, Humidity: 40 ±5 %)

Tested Interface	Contact Discharge	Air Discharge	Unit
------------------	-------------------	---------------	------

VCC, GND	±5	±10	kV
Antenna Interfaces	±4	±8	kV
Other Interfaces	±0.5	±1	kV

6.6. Operating and Storage Temperatures

Table 58: Operating and Storage Temperatures

Parameter	Min.	Typ.	Max.	Unit
Operating Temperature Range ¹⁶	-25	+25	+75	°C
Extended Temperature Range ¹⁷	-40	-	+85	°C
Storage temperature Range	-40	-	+90	°C

¹⁶ To meet this operating temperature range, you need to ensure effective thermal dissipation, for example, by adding passive or active heatsinks, heat pipes, vapor chambers, etc. Within this range, the module meets 3GPP specifications.

¹⁷ To meet this extended temperature range, you need to ensure effective thermal dissipation, for example, by adding passive or active heatsinks, heat pipes, vapor chambers, etc. Within this range, the module remains the ability to establish and maintain functions such as voice*, SMS, emergency call* etc., without any unrecoverable malfunction. Radio spectrum and radio network are not influenced, while one or more specifications, such as Pout, may undergo a reduction in value, exceeding the specified tolerances of 3GPP. When the temperature returns to the normal operating temperature level, the module will meet 3GPP specifications again.

6.7. Thermal Dissipation

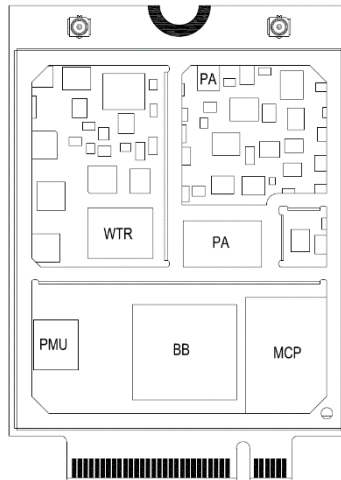

Figure 34: Distribution of Heat Source Chips Inside the EM060K-GL&EM120K-GL

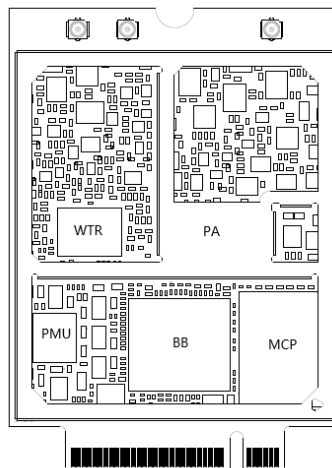

Figure 35: Distribution of Heat Source Chips Inside the EM060K-NA

The module offers the best performance when all internal IC chips are working within their operating temperatures. When the IC chip reaches or exceeds the maximum junction temperature, the module may still work but the performance and function (such as RF output power, data rate, etc.) will be affected to a certain extent. Therefore, the thermal design should be maximally optimized to ensure all internal IC chips always work within the recommended operating temperature range.

The following principles for thermal consideration are provided for reference:

- Keep the module away from heat sources on your PCB, especially high-power components such as processor, power amplifier, and power supply.

- Maintain the integrity of the PCB copper layer and drill as many thermal vias as possible.
- Expose the copper in the PCB area where module is mounted.
- Apply a soft thermal pad with appropriate thickness and high thermal conductivity between the module and the PCB to conduct heat.
- Follow the principles below when the heatsink is necessary:
 - Do not place large size components in the area where the module is mounted on your PCB to reserve enough place for heatsink installation.
 - Attach the heatsink to the shielding cover of the module; In general, the base plate area of the heatsink should be larger than the module area to cover the module completely;
 - Choose the heatsink with adequate fins to dissipate heat;
 - Choose a TIM (Thermal Interface Material) with high thermal conductivity, good softness and good wettability and place it between the heatsink and the module;
 - Fasten the heatsink with four screws to ensure that it is in close contact with the module to prevent the heatsink from falling off during the drop, vibration test, or transportation.

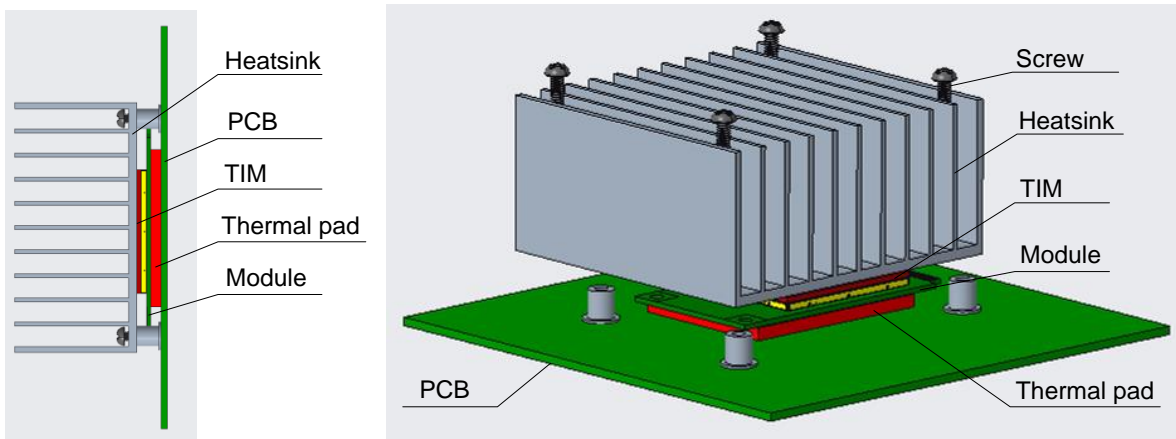

Figure 36: Placement and Fixing of the Heatsink

Table 59: Maximum Operating Temperature for Main Chips (Unit: °C)

BASEBAND	MCP	PMU	WTR	MMPA	PA	APT
85	85	85	85	100	85	85

6.8. Notification

Please follow the principles below in the module application.

6.8.1. Coating

If a conformal coating is necessary for the module, do NOT use any coating material that may chemically react with the PCB or shielding cover, and prevent the coating material from flowing into the module.

6.8.2. Cleaning

Avoid using ultrasonic technology for module cleaning since it can damage crystals inside the module.

6.8.3. Installing

It is recommended to fix the module firmly when the module is inserted into a socket.

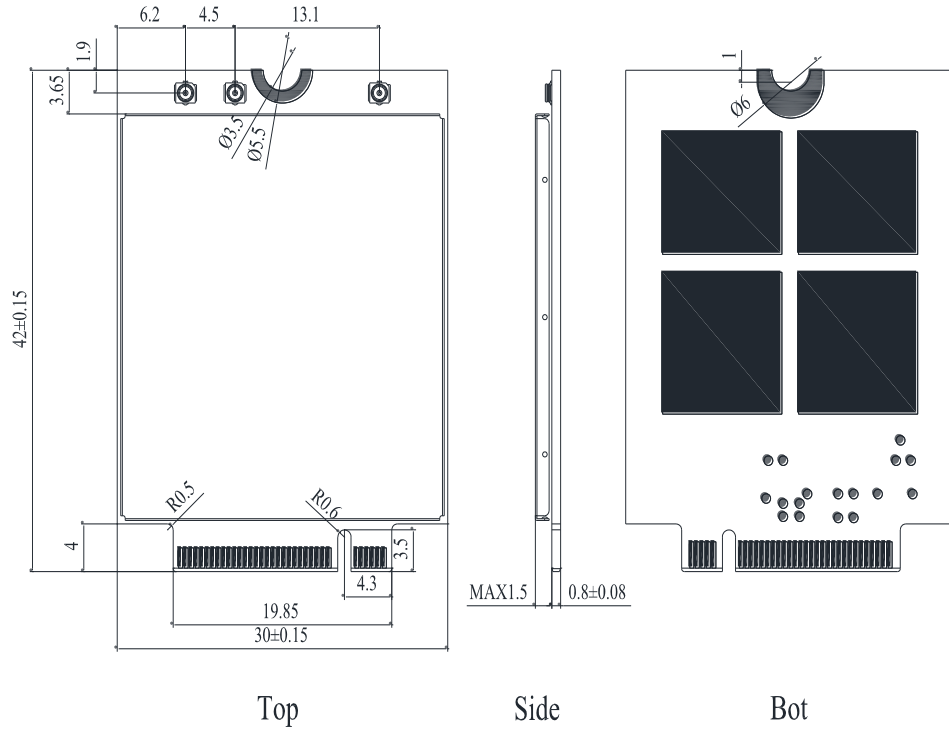

Figure 38: EM060K-NA Mechanical Dimensions

7.2. Top and Bottom Views



Figure 39: EM060K-GL Top and Bottom Views



Figure 40: EM120K-GL Top and Bottom Views



Figure 41: EM060K-NA Top and Bottom Views



Figure 42: EM060K-EA Top and Bottom Views

NOTE

Images above are for illustration purpose only and may differ from the actual modules. For authentic appearance and label, please refer to the module received from Quectel.

7.3. M.2 Connector

EM060K series and EM120K-GL adopt a standard PCI Express M.2 connector which complies with the directives and standards listed in PCI Express M.2 Specification.

7.4. Module Installation

The module needs to be fixed firmly to avoid poor contact caused by shaking. When installing the module, it is recommended to be mounted on the socket with a screw as shown below.

It is recommended to use a screw with a head diameter $\varnothing 5\text{--}\varnothing 5.5\text{ mm}$.

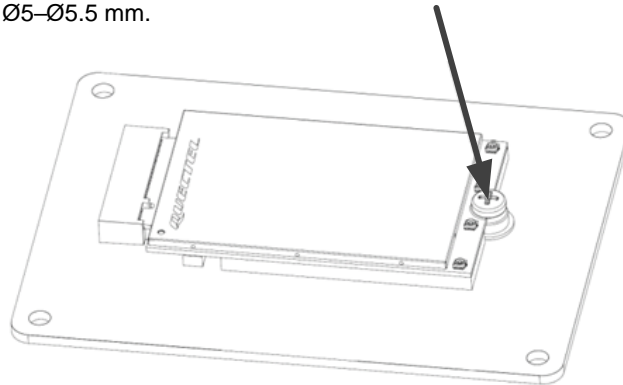

Figure 43: Installation Schematic

7.5. Packaging Specification

This chapter describes only the key parameters and process of packaging. All figures below are for reference only. The appearance and structure of the packaging materials are subject to the actual delivery.

The module adopts blister tray packaging and details are as follow:

7.5.1. Blister Tray

Dimension details are as follow:

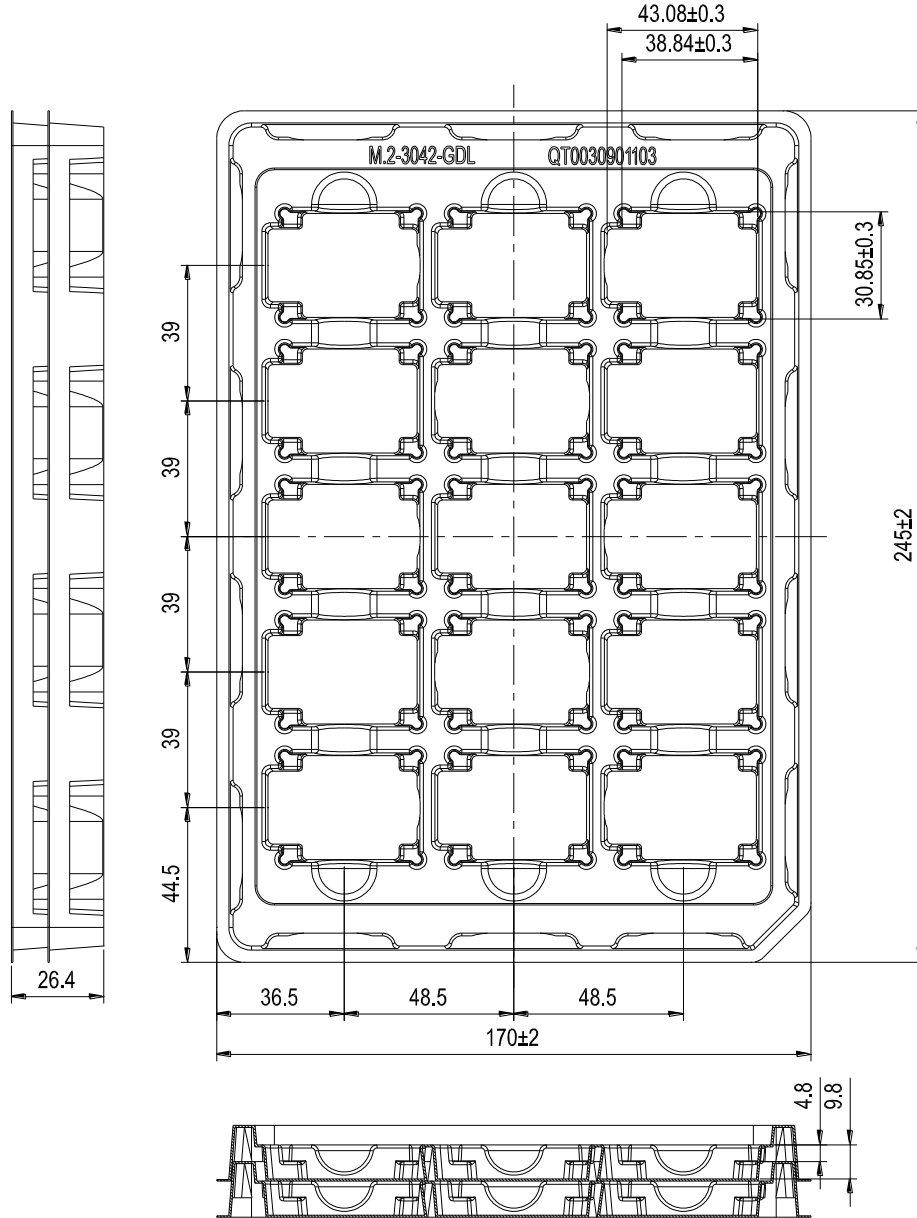
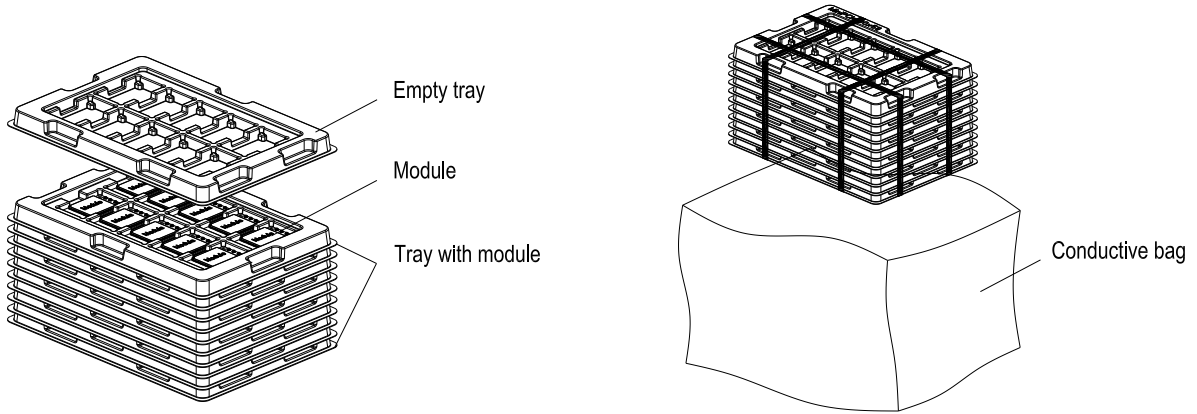

Figure 44: Blister Tray Dimension Drawing

7.5.2. Packaging Process



Each blister tray packs 15 modules. Stack 10 blister trays with modules together, and put 1 empty blister tray on the top.

Packing 11 blister trays together and then put blister trays into conductive bag, seal and pack the conductive bag.

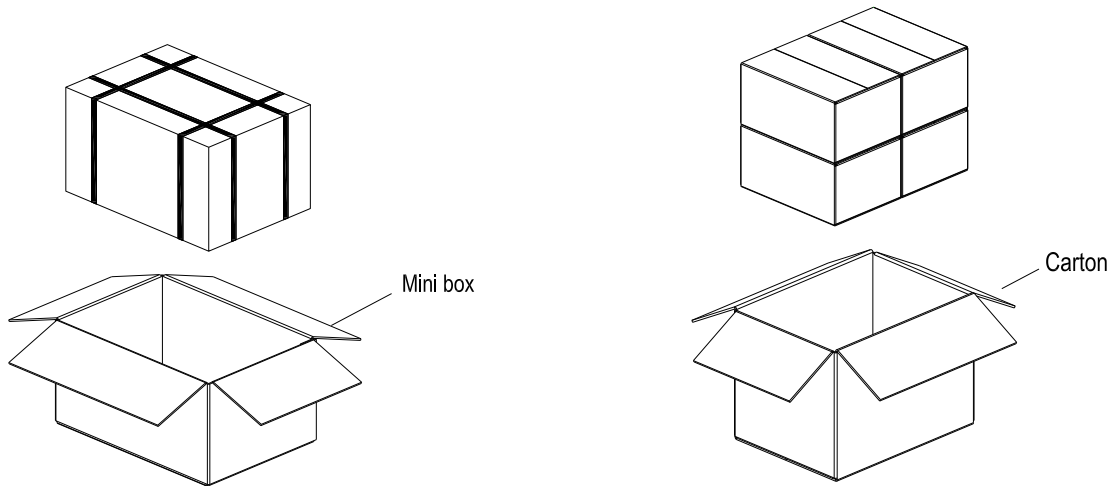

Put the seal-packed blister trays into the mini box. 1 mini box can pack 150 modules.

Put 4 packaged mini boxes into 1 carton box and then seal it. 1 carton box can pack 600 modules.

Figure 45: Packaging Process

8 Appendix References

Table 60: Related Documents

Document Name
[1] Quectel_EM060K_Series&EM120K-GL_CA_Feature
[2] Quectel_5G-M2_EVB_User_Guide
[3] Quectel_EG06xK&Ex120K&EM060K_Series_AT_Commands_Manual
[4] Quectel_LTE-A(Q)_Series_GNSS_Application_Note

Table 61: Terms and Abbreviations

Abbreviation	Description
APT	Average Power Tracking
AT	ATtention
BB	Baseband
BDS	BeiDou Navigation Satellite System
BIOS	Basic Input/Output System
bps	Bit(s) per second
BPSK	Binary Phase Shift Keying
CBRS	Citizen Broadband Radio Service
CPE	Customer-Premise Equipment
COEX	Coexistence
DC-HSDPA	Dual-carrier High Speed Downlink Package Access

DFOTA	Delta Firmware Upgrade Over-The-Air
DL	Downlink
DPR	Dynamic Power Reduction
DRX	Discontinuous Reception
DRx	Diversity Receive
EBI	External Bus Interface
EIRP	Equipment Isotropic Radiated Power
ESD	Electrostatic Discharge
ESR	Equivalent Series Resistance
FDD	Frequency Division Duplex
GLONASS	Global Navigation Satellite System (Russia)
GNSS	Global Navigation Satellite System
GPS	Global Positioning System
GSM	Global System for Mobile Communications
HSDPA	High Speed Downlink Packet Access
HSPA	High Speed Packet Access
HSUPA	High Speed Uplink Packet Access
IC	Integrated Circuit
kbps	Kilobits per second
LAA	License Assisted Access
LDO	Low-dropout Regulator
LED	Light Emitting Diode
LPDDR2	Low Power Double Data Rate 2
LSB	Least Significant Bit
LTE	Long Term Evolution

MBIM	Mobile Broadband Interface Model
Mbps	Megabits per second
MCP	Multiple Chip Package
ME	Mobile Equipment
MFBI	Multi-Frequency Band Indicator
MIPI	Mobile Industry Processor Interface
MIMO	Multiple-Input Multiple-Output
MLCC	Multi-layer Ceramic Capacitor
MMPA	Multimode Multiband Power Amplifier
MO	Mobile Originated
MSB	Most Significant Bit
MT	Mobile Terminated
NAND	NON-AND
NC	Not Connected
NPN	Negative-Positive-Negative
PA	Power Amplifier
PAP	Password Authentication Protocol
PC	Personal Computer
PCB	Printed Circuit Board
PCIe	Peripheral Component Interconnect Express
PCM	Pulse Code Modulation
PDU	Protocol Data Unit
PME	Power Management Event
PMIC	Power Management IC
PMU	Power Management Unit

POS	Point of Sale
PPP	Point-to-Point Protocol
PRx	Primary Receive
QLN	Qualcomm Low-noise Amplifier
QMI	Qualcomm MSM (Mobile Station Modems) Interface
QPSK	Quadrature Phase Shift Keying
RB	Resource Block
RF	Radio Frequency
RFFE	RF Front-End
RH	Relative Humidity
Rx	Receive
SAR	Specific Absorption Rate
SDRAM	Synchronous Dynamic Random-Access Memory
SMS	Short Message Service
SPMI	System Power Management Interface
TCP	Transmission Control Protocol
TDD	Time Division Duplex
TRx	Transmit & Receive
Tx	Transmit
UART	Universal Asynchronous Receiver/Transmitter
UDP	User Datagram Protocol
UL	Uplink
URC	Unsolicited Result Code
USB	Universal Serial Bus
(U)SIM	(Universal) Subscriber Identity Module

VFB	Voltage Feedback
V _{IH}	High-level Input Voltage
V _{IL}	Low-level Input Voltage
V _{OH}	High-level Output Voltage
V _{OL}	Low-level Output Voltage
WCDMA	Wideband Code Division Multiple Access
WTR	Wafer-scale RF transceiver
XO	Crystal Oscillator

Product Marketing Name: Quectel EM120K-GL

FCC Certification Requirements.

According to the definition of mobile and fixed device is described in Part 2.1091(b), this device is a mobile device. And the following conditions must be met:

- 1.This Modular Approval is limited to OEM installation for mobile and fixed applications only. The antenna installation and operating configurations of this transmitter, including any applicable source-based timeaveraging duty factor, antenna gain and cable loss must satisfy MPE categorical Exclusion Requirements of 2.1091.
- 2.The EUT is a mobile device; maintain at least a 20 cm separation between the EUT and the user's body and must not transmit simultaneously with any other antenna or transmitter.
- 3.A label with the following statements must be attached to the host end product: This device contains FCC ID: XMR2022EM120KGL
4. To comply with FCC regulations limiting both maximum RF output power and human exposure to RF radiation, maximum antenna gain (including cable loss) must not exceed:

radiation, maximum antenna gain (including cable loss) must not exceed: Operating Band	FCC Max Antenna Gain (dBi)
WCDMA B2	8.00
WCDMA B4	5.00
WCDMA B5	9.42
LTE B2	8.00
LTE B4	5.00
LTE B5	9.41
LTE B7	8.00
LTE B12	8.70
LTE B13	9.16
LTE B14	9.23
LTE B17	8.74
LTE B25	8.00
LTE B26(814~824)	9.36
LTE B26(824~849)	9.41
LTE B30	-1.02
LTE B38	8.00
LTE B41	8.00
LTE B42(3450~3550)	5.00
LTE B42(3550~3600)	-2.00
LTE B43(3600~3700)	-2.00
LTE B48	-2.00
LTE B66	5.00
LTE B71	8.48

5. This module must not transmit simultaneously with any other antenna or transmitter

6. The host end product must include a user manual that clearly defines operating requirements and conditions that must be observed to ensure compliance with current FCC RF exposure guidelines.

For portable devices, in addition to the conditions 3 through 6 described above, a separate approval is required to satisfy the SAR requirements of FCC Part 2.1093

If the device is used for other equipment that separate approval is required for all other operating configurations, including portable configurations with respect to 2.1093 and different antenna configurations.

For this device, OEM integrators must be provided with labeling instructions of finished products.

Please refer to KDB784748 D01 v07, section 8. Page 6/7 last two paragraphs:

A certified modular has the option to use a permanently affixed label, or an electronic label. For a permanently affixed label, the module must be labeled with an FCC ID - Section 2.926 (see 2.2 Certification (labeling requirements) above).

The OEM manual must provide clear instructions explaining to the OEM the labeling requirements, options and OEM user manual instructions that are required (see next paragraph).

For a host using a certified modular with a standard fixed label, if (1) the module's FCC ID is not visible when installed in the host, or (2) if the host is marketed so that end users do not have straightforward commonly used methods for access to remove the module so that the FCC ID of the module is visible; then an additional permanent label referring to the enclosed module: "Contains Transmitter Module FCC ID: XMR2022EM120KGL" or "Contains FCC ID: XMR2022EM120KGL" must be used. The host OEM user manual must also contain clear instructions on how end users can find and/or access the module and the FCC ID.

The final host / module combination may also need to be evaluated against the FCC Part 15B criteria for unintentional radiators in order to be properly authorized for operation as a Part 15 digital device.

The user's manual or instruction manual for an intentional or unintentional radiator shall caution the user that changes or modifications not expressly approved by the party responsible for compliance could void the user's authority to operate the equipment. In cases where the manual is provided only in a form other than paper, such as on a computer disk or over the Internet, the information required by this section may be included in the manual in that alternative form, provided the user can reasonably be expected to have the capability to access information in that form.

This device complies with part 15 of the FCC Rules. Operation is subject to the following two conditions:

(1) This device may not cause harmful interference, and (2) this device must accept any interference received, including interference that may cause undesired operation.

Changes or modifications not expressly approved by the manufacturer could void the user's authority to operate the equipment.

To ensure compliance with all non-transmitter functions the host manufacturer is responsible for ensuring compliance with the module(s) installed and fully operational. For example, if a host was previously authorized as an unintentional radiator under the Supplier's Declaration of Conformity procedure without a transmitter certified module and a module is added, the host manufacturer is responsible for ensuring that after the module is installed and operational the host continues to be compliant with the Part 15B unintentional radiator requirements.

This device complies with Part 22(H), Part 24(E), Part 27, Part 90 and Part 96 of the FCC Rules. The FCC ID for this device is XMR2022EM120KGL.

Antenna change notice

If you desire to increase antenna gain and either change antenna type or use same antenna type certified, a Class II permissive change application is required to be filed by us, or you (host manufacturer) can take responsibility through the change in FCC ID (new application) procedure followed by a Class II permissive change application

Information on test modes and additional testing requirements

The OEM integrator is responsible for ensuring that the end-user has no manual instruction to remove or install the module. The module is limited to installation in mobile applications, a separate approval is required for all other operating configurations, including portable configurations with respect to Part 2.1093 and different antenna configurations

Test software to access different test modes: p2radio

Testing item, frequencies, transmit power can be selected following the test script instructions

Manual Information To the End User

The OEM integrator has to be aware not to provide information to the end user regarding how to install or remove this RF module in the user's manual of the end product which integrates this module. The end user manual shall include all required regulatory information/warning as shown in this manual.

IC Statement

IRSS-GEN

"This device complies with Industry Canada's licence-exempt RSSs. Operation is subject to the following two conditions:

(1) This device may not cause interference; and (2) This device must accept any interference, including interference that may cause undesired operation of the device." or "Le présent appareil est conforme aux CNR d'Industrie Canada applicables aux appareils radio exempts de licence. L'exploitation est autorisée aux deux conditions suivantes :

1) l'appareil ne doit pas produire de brouillage; 2) l'utilisateur de l'appareil doit accepter tout brouillage radioélectrique subi, même si le brouillage est susceptible d'en compromettre le fonctionnement."

Déclaration sur l'exposition aux rayonnements RF

L'autre utilisé pour l'émetteur doit être installé pour fournir une distance de séparation d'au moins 20 cm de toutes les personnes et ne doit pas être colocalisé ou fonctionner conjointement avec une autre antenne ou un autre émetteur.

The host product shall be properly labeled to identify the modules within the host product.

The Innovation, Science and Economic Development Canada certification label of a module shall be clearly visible at all times when installed in the host product; otherwise, the host product must be labeled to display the Innovation, Science and Economic Development Canada certification number for the module, preceded by the word "Contains" or similar wording expressing the same meaning, as follows:

"Contains IC: 10224A-22EM120KGL" or "where: 10224A-22EM120KGL is the module's certification number".

Le produit hôte doit être correctement étiqueté pour identifier les modules dans le produit hôte.

L'étiquette de certification d'Innovation, Sciences et Développement économique Canada d'un module doit être clairement visible en tout temps lorsqu'il est installé dans le produit hôte; sinon, le produit hôte doit porter une étiquette indiquant le numéro de certification d'Innovation, Sciences et Développement économique Canada pour le module, précédé du mot «Contient» ou d'un libellé semblable exprimant la même signification, comme suit:

"Contient IC: 10224A-22EM120KGL" ou "où: 10224A-22EM120KGL est le numéro de certification du module".

This radio transmitter [10224A-22EM120KGL] has been approved by Innovation, Science and Economic Development Canada to operate with the antenna types listed below, with the maximum permissible gain indicated. Antenna types not included in this list that have a gain greater than the maximum gain indicated for any type listed are strictly prohibited for use with this device.