

EG25-GL

Hardware Design

LTE Standard Module Series

Version: 1.0.0

Date: 2022-09-09

Status: Preliminary



At Quectel, our aim is to provide timely and comprehensive services to our customers. If you require any assistance, please contact our headquarters:

Quectel Wireless Solutions Co., Ltd.

Building 5, Shanghai Business Park Phase III (Area B), No.1016 Tianlin Road, Minhang District, Shanghai 200233, China

Tel: +86 21 5108 6236

Email: info@quectel.com

Or our local offices. For more information, please visit:

<http://www.quectel.com/support/sales.htm>.

For technical support, or to report documentation errors, please visit:

<http://www.quectel.com/support/technical.htm>.

Or email us at: support@quectel.com.

Legal Notices

We offer information as a service to you. The provided information is based on your requirements and we make every effort to ensure its quality. You agree that you are responsible for using independent analysis and evaluation in designing intended products, and we provide reference designs for illustrative purposes only. Before using any hardware, software or service guided by this document, please read this notice carefully. Even though we employ commercially reasonable efforts to provide the best possible experience, you hereby acknowledge and agree that this document and related services hereunder are provided to you on an “as available” basis. We may revise or restate this document from time to time at our sole discretion without any prior notice to you.

Use and Disclosure Restrictions

License Agreements

Documents and information provided by us shall be kept confidential, unless specific permission is granted. They shall not be accessed or used for any purpose except as expressly provided herein.

Copyright

Our and third-party products hereunder may contain copyrighted material. Such copyrighted material shall not be copied, reproduced, distributed, merged, published, translated, or modified without prior written consent. We and the third party have exclusive rights over copyrighted material. No license shall be granted or conveyed under any patents, copyrights, trademarks, or service mark rights. To avoid ambiguities, purchasing in any form cannot be deemed as granting a license other than the normal non-exclusive, royalty-free license to use the material. We reserve the right to take legal action for noncompliance with abovementioned requirements, unauthorized use, or other illegal or malicious use of the material.

Trademarks

Except as otherwise set forth herein, nothing in this document shall be construed as conferring any rights to use any trademark, trade name or name, abbreviation, or counterfeit product thereof owned by Quectel or any third party in advertising, publicity, or other aspects.

Third-Party Rights

This document may refer to hardware, software and/or documentation owned by one or more third parties (“third-party materials”). Use of such third-party materials shall be governed by all restrictions and obligations applicable thereto.

We make no warranty or representation, either express or implied, regarding the third-party materials, including but not limited to any implied or statutory, warranties of merchantability or fitness for a particular purpose, quiet enjoyment, system integration, information accuracy, and non-infringement of any third-party intellectual property rights with regard to the licensed technology or use thereof. Nothing herein constitutes a representation or warranty by us to either develop, enhance, modify, distribute, market, sell, offer for sale, or otherwise maintain production of any our products or any other hardware, software, device, tool, information, or product. We moreover disclaim any and all warranties arising from the course of dealing or usage of trade.

Privacy Policy

To implement module functionality, certain device data are uploaded to Quectel’s or third-party’s servers, including carriers, chipset suppliers or customer-designated servers. Quectel, strictly abiding by the relevant laws and regulations, shall retain, use, disclose or otherwise process relevant data for the purpose of performing the service only or as permitted by applicable laws. Before data interaction with third parties, please be informed of their privacy and data security policy.

Disclaimer

- a) We acknowledge no liability for any injury or damage arising from the reliance upon the information.
- b) We shall bear no liability resulting from any inaccuracies or omissions, or from the use of the information contained herein.
- c) While we have made every effort to ensure that the functions and features under development are free from errors, it is possible that they could contain errors, inaccuracies, and omissions. Unless otherwise provided by valid agreement, we make no warranties of any kind, either implied or express, and exclude all liability for any loss or damage suffered in connection with the use of features and functions under development, to the maximum extent permitted by law, regardless of whether such loss or damage may have been foreseeable.
- d) We are not responsible for the accessibility, safety, accuracy, availability, legality, or completeness of information, advertising, commercial offers, products, services, and materials on third-party websites and third-party resources.

Copyright © Quectel Wireless Solutions Co., Ltd. 2022. All rights reserved.

Safety Information

The following safety precautions must be observed during all phases of operation, such as usage, service or repair of any cellular terminal or mobile incorporating the module. Manufacturers of the cellular terminal should notify users and operating personnel of the following safety information by incorporating these guidelines into all manuals of the product. Otherwise, Quectel assumes no liability for your failure to comply with these precautions.



Full attention must be paid to driving at all times in order to reduce the risk of an accident. Using a mobile while driving (even with a handsfree kit) causes distraction and can lead to an accident. Please comply with laws and regulations restricting the use of wireless devices while driving.



Switch off the cellular terminal or mobile before boarding an aircraft. The operation of wireless appliances in an aircraft is forbidden to prevent interference with communication systems. If there is an Airplane Mode, it should be enabled prior to boarding an aircraft. Please consult the airline staff for more restrictions on the use of wireless devices on an aircraft.



Wireless devices may cause interference on sensitive medical equipment, so please be aware of the restrictions on the use of wireless devices when in hospitals, clinics or other healthcare facilities.



Cellular terminals or mobiles operating over radio signal and cellular network cannot be guaranteed to connect in certain conditions, such as when the mobile bill is unpaid or the (U)SIM card is invalid. When emergency help is needed in such conditions, use emergency call if the device supports it. In order to make or receive a call, the cellular terminal or mobile must be switched on in a service area with adequate cellular signal strength. In an emergency, the device with emergency call function cannot be used as the only contact method considering network connection cannot be guaranteed under all circumstances.



The cellular terminal or mobile contains a transceiver. When it is ON, it receives and transmits radio frequency signals. RF interference can occur if it is used close to TV sets, radios, computers or other electric equipment.



In locations with explosive or potentially explosive atmospheres, obey all posted signs and turn off wireless devices such as mobile phone or other cellular terminals. Areas with explosive or potentially explosive atmospheres include fuelling areas, below decks on boats, fuel or chemical transfer or storage facilities, and areas where the air contains chemicals or particles such as grain, dust or metal powders.

About the Document

Revision History

Version	Date	Author	Description
-	2022-09-09	Ethan FANG/Joe MA	Creation of the document
1.0.0	2022-09-09	Ethan FANG/Joe MA	Preliminary

Contents

Safety Information	3
About the Document	4
Contents	5
Table Index	8
Figure Index	10
1 Introduction	12
1.1 Special Marks.....	12
2 Product Overview	13
2.1 Frequency Bands and Functions.....	13
2.2 Key Features.....	14
2.3 Functional Diagram.....	17
2.4 Pin Assignment.....	18
2.5 Pin Description.....	19
2.6 EVB Kit.....	27
3 Operating Characteristics	28
3.1 Operating Modes.....	28
3.2 Sleep Mode.....	29
3.2.1 UART Application Scenario.....	29
3.2.2 USB Application Scenario.....	29
3.2.2.1 USB Application with USB Remote Wakeup Function.....	29
3.2.2.2 USB Application with USB Suspend/Resume and MAIN_RI Function.....	30
3.2.2.3 USB Application without USB Suspend Function.....	31
3.2.3 Airplane Mode.....	31
3.3 Power Supply.....	32
3.3.1 Power Supply Pins.....	32
3.3.2 Voltage Stability Requirements.....	33
3.3.3 Reference Design for Power Supply.....	34
3.3.4 Power Supply Voltage Monitoring.....	35
3.4 Turn On.....	35
3.4.1 Turn On with PWRKEY.....	35
3.5 Turn Off.....	37
3.5.1 Turn Off with PWRKEY.....	37
3.5.2 Turn Off with AT Command.....	37
3.6 Reset.....	38
4 Application Interfaces	40
4.1 (U)SIM Interface.....	40
4.2 USB Interface.....	42
4.3 UART Interfaces.....	43
4.4 PCM and I2C Interfaces.....	46

4.5	SD Card Interface	48
4.6	WLAN and Bluetooth Application Interfaces	50
4.6.1	WLAN Application Interface	53
4.6.2	Bluetooth Application Interface*	53
4.7	ADC Interfaces	53
4.8	SGMII Interface.....	54
4.9	Indication Signals.....	56
4.9.1	Network Status Indication	56
4.9.2	STATUS.....	58
4.9.3	MAIN_RI.....	58
4.10	USB_BOOT	59
5	RF Specifications.....	61
5.1	Cellular Network	61
5.1.1	Antenna Interface & Frequency Bands.....	61
5.1.2	Tx Power	63
5.1.3	Rx Sensitivity.....	63
5.1.4	Reference Design	65
5.2	GNSS.....	66
5.2.1	Antenna Interface & Frequency Bands.....	66
5.2.2	GNSS Performance	67
5.2.3	Reference Design	68
5.3	RF Routing Guidelines	68
5.4	Antenna Design Requirements	70
5.5	RF Connector Recommendation.....	71
6	Electrical Characteristics and Reliability	73
6.1	Absolute Maximum Ratings.....	73
6.2	Power Supply Ratings	74
6.3	Power Consumption	74
6.4	ESD Protection	79
6.5	Operating and Storage Temperatures.....	80
7	Mechanical Information.....	81
7.1	Mechanical Dimensions.....	81
7.2	Recommended Footprint.....	83
7.3	Recommended Compatible Footprint.....	84
7.4	Top and Bottom Views.....	85
8	Storage, Manufacturing and Packaging	86
8.1	Storage Conditions	86
8.2	Manufacturing and Soldering	87
8.3	Packaging Specifications.....	88
8.3.1	Carrier Tape.....	89
8.3.2	Plastic Reel	89
8.3.3	Packaging Process	90

9. Appendix References 92

Table Index

Table 1: Special Marks	12
Table 2: Frequency Bands and Functions	13
Table 3: Key Features of EG25-GL Module	14
Table 4: I/O Parameters Definition	19
Table 5: Pin Description	20
Table 6: Overview of Operating Modes.....	28
Table 7: Pin Definition of VBAT and GND Pins.....	32
Table 8: Pin Definition of PWRKEY.....	35
Table 9: Pin Definition of RESET_N.....	38
Table 10: Pin Definition of (U)SIM Interface.....	40
Table 11: Pin Definition of USB Interface	42
Table 12: Pin Definition of Main UART Interface	44
Table 13: Pin Definition of Debug UART Interface.....	44
Table 14: Pin Definition of PCM and I2C Interfaces	47
Table 15: Pin Definition of SD Card Interface	48
Table 16: Pin Definition of WLAN & Bluetooth Application Interfaces	50
Table 17: Pin Definition of ADC Interfaces.....	53
Table 18: Characteristic of ADC	54
Table 19: Pin Definition of SGMII Interface.....	54
Table 20: Pin Definition of Network Connection Status/Activity Indication	57
Table 21: Working State of Network Connection Status/Activity Indication.....	57
Table 22: Pin Definition of STATUS.....	58
Table 23: Behaviors of MAIN_RI	59
Table 24: Pin Definition of USB_BOOT Interface	59
Table 25: Pin Definition of Antenna Antennas.....	61
Table 26: Frequency Bands	61
Table 27: Tx Power.....	63
Table 28: EG25-GL Conducted RF Receiving Sensitivity.....	63
Table 29: Pin Definition of GNSS Antenna Interface	66
Table 30: GNSS Frequency	66
Table 31: GNSS Performance.....	67
Table 32: Antenna Requirements.....	70
Table 33: Absolute Maximum Ratings.....	73
Table 34: Power Supply Ratings	74
Table 35: EG25-GL Current Consumption	74
Table 36: Electrostatic Discharge Characteristics (25 °C, 45 % Relative Humidity)	79
Table 37: Operating and Storage Temperatures.....	80
Table 38: Recommended Thermal Profile Parameters.....	88
Table 39: Carrier Tape Dimension Table (Unit: mm)	89
Table 40: Plastic Reel Dimension Table (Unit: mm).....	90
Table 41: Related Documents.....	92

Table 42: Terms and Abbreviations 92

Figure Index

Figure 1: Functional Diagram..... 17

Figure 2: Pin Assignment (Top View) 18

Figure 3: Sleep Mode Application via UART..... 29

Figure 4: Sleep Mode Application with USB Remote Wakeup 30

Figure 5: Sleep Mode Application with MAIN_RI..... 30

Figure 6: Sleep Mode Application without Suspend Function 31

Figure 7: Power Supply Limits during Burst Transmission 33

Figure 8: Star Structure of the Power Supply 34

Figure 9: Reference Circuit of Power Supply..... 34

Figure 10: Turn On the Module by Using Driving Circuit 35

Figure 11: Turn On the Module by Using a Button..... 36

Figure 12: Power-up Timing 36

Figure 13: Power-down Timing 37

Figure 14: Reference Circuit of RESET_N by Using Driving Circuit 38

Figure 15: Reference Circuit of RESET_N by Using a Button 39

Figure 16: Reset Timing 39

Figure 17: Reference Circuit of (U)SIM Interface with an 8-pin (U)SIM Card Connector 41

Figure 18: Reference Circuit of (U)SIM Interface with a 6-pin (U)SIM Card Connector 41

Figure 19: Reference Circuit of USB Interface 43

Figure 20: Reference Circuit with Translator Chip 45

Figure 21: Reference Circuit with Transistor Circuit 45

Figure 22: Primary Mode Timing 46

Figure 23: Auxiliary Mode Timing 47

Figure 24: Reference Circuit of PCM and I2C Application with Audio Codec 48

Figure 25: Reference Circuit of SD Card Interface 49

Figure 26: Reference Circuit of WLAN & Bluetooth Application Interfaces with FC20 Series/FC21 52

Figure 27: Simplified Block Diagram for Ethernet Application 55

Figure 28: Reference Circuit of SGMII Interface with PHY AR8033 Application 56

Figure 29: Reference Circuit of the Network Indication 57

Figure 30: Reference Circuits of STATUS 58

Figure 31: Reference Circuit of USB_BOOT Interface 60

Figure 32: Timing Sequence for Entering Emergency Download Mode..... 60

Figure 33: Reference Circuit of RF Antenna Interface..... 65

Figure 34: Reference Circuit of GNSS Antenna 67

Figure 35: Microstrip Design on a 2-layer PCB 69

Figure 36: Coplanar Waveguide Design on a 2-layer PCB 69

Figure 37: Coplanar Waveguide Design on a 4-layer PCB (Layer 3 as Reference Ground)..... 69

Figure 38: Coplanar Waveguide Design on a 4-layer PCB (Layer 4 as Reference Ground)..... 70

Figure 39: Dimensions of the Receptacle (Unit: mm)..... 71

Figure 40: Specifications of Mated Plugs 72

Figure 41: Space Factor of Mated Connectors (Unit: mm)..... 72

Figure 42: Module Top and Side Dimensions	81
Figure 43: Bottom Dimensions (Bottom View)	82
Figure 44: Recommended Footprint (Top View)	83
Figure 45: Recommended Compatible Footprint (Top View).....	84
Figure 46: Top and Bottom Views of the Module	85
Figure 47: Recommended Reflow Soldering Thermal Profile	87
Figure 48: Carrier Tape Dimension Drawing.....	89
Figure 49: Plastic Reel Dimension Drawing	89
Figure 50: Packaging Process	91

1 Introduction

This document defines EG25-GL module and describes its air interface and hardware interfaces which are connected with your applications.

With this document, you can quickly understand module interface specifications, electrical and mechanical details, as well as other related information of the module. The document, coupled with application notes and user guides, makes it easy to design and set up mobile applications with the module.

1.1 Special Marks

Table 1: Special Marks

Mark	Definition
*	Unless otherwise specified, when an asterisk (*) is used after a function, feature, interface, pin name, AT command, or argument, it indicates that the function, feature, interface, pin, AT command, or argument is under development and currently not supported; and the asterisk (*) after a model indicates that the sample of the model is currently unavailable.
[...]	Brackets ([...]) used after a pin enclosing a range of numbers indicate all pins of the same type. For example, SDIO_DATA[0:3] refers to all four SDIO pins: SDIO_DATA0, SDIO_DATA1, SDIO_DATA2, and SDIO_DATA3.

2 Product Overview

2.1 Frequency Bands and Functions

EG25-GL is an LTE/WCDMA/GSM wireless communication module with receive diversity. It provides data connectivity on LTE-FDD, LTE-TDD, DC-HSDPA, HSPA+, HSDPA, HSUPA, UMTS, EDGE and GPRS networks. It also provides GNSS and voice functionality for your specific applications. The following table shows the supported frequency bands, GNSS and digital audio functions of EG25-GL module.

Table 2: Frequency Bands and Functions

Mode	EG25-GL
GSM	GSM850/EGSM900/DCS1800/PCS1900
WCDMA (With receive diversity)	B1/B2/B4/B5/B6/B8/B19
LTE-FDD (With receive diversity)	B1/B2/B3/B4/B5/B7/B8/B12/B13/B18/B19/B20/B25/B26/B28/B66
LTE-TDD (With receive diversity)	B34/B38/B39/B40/B41
GNSS (Optional)	GPS, GLONASS, BDS, Galileo, QZSS
Digital Audio (PCM)	Supported
VoLTE (Voice over LTE)	Optional

With a compact profile of 29.0 mm × 32.0 mm × 2.4 mm, EG25-GL can meet most requirements for M2M applications such as automation, smart metering, tracking system, security, router, wireless POS, mobile computing device, PDA phone, tablet PC, etc.

EG25-GL is an SMD type module which can be embedded into applications through its 144 LGA ¹ pins.

¹ LGA form factor is used for EG25-GL module, while LCC is recommended only in the compatible design with EC25 series/EC21 series/EC20-CE/EG21-G/EG25-G/EC200A series modules.

2.2 Key Features

The following table describes the detailed features of EG25-GL module.

Table 3: Key Features of EG25-GL Module

Features	Description
Power Supply	<ul style="list-style-type: none"> ● Supply voltage: 3.3–4.3 V ● Typical supply voltage: 3.8 V
Transmitting Power	<ul style="list-style-type: none"> ● Class 4 (33 dBm \pm2 dB) for GSM850 ● Class 4 (33 dBm \pm2 dB) for EGSM900 ● Class 1 (30 dBm \pm2 dB) for DCS1800 ● Class 1 (30 dBm \pm2 dB) for PCS1900 ● Class E2 (27 dBm \pm3 dB) for GSM850 8-PSK ● Class E2 (27 dBm \pm3 dB) for EGSM900 8-PSK ● Class E2 (26 dBm \pm3 dB) for DCS1800 8-PSK ● Class E2 (26 dBm \pm3 dB) for PCS1900 8-PSK ● Class 3 (24 dBm +1/-3 dB) for WCDMA bands ● Class 3 (23 dBm \pm2 dB) for LTE-FDD bands ● Class 3 (23 dBm \pm2 dB) for LTE-TDD bands
LTE Features	<ul style="list-style-type: none"> ● Supports up to non-CA Cat 4 FDD and TDD ● Supports 1.4/3/5/10/15/20 MHz RF bandwidth ● Supports MIMO in DL direction ● LTE-FDD: Max. 150 Mbps (DL), Max. 50 Mbps (UL) ● LTE-TDD: Max. 130 Mbps (DL), Max. 30 Mbps (UL)
UMTS Features	<ul style="list-style-type: none"> ● Supports 3GPP Rel-8 DC-HSDPA, HSPA+, HSDPA, HSUPA and WCDMA ● Supports QPSK, 16QAM and 64QAM modulation ● DC-HSDPA: Max. 42 Mbps (DL) ● HSUPA: Max. 5.76 Mbps (UL) ● WCDMA: Max. 384 kbps (DL), Max. 384 kbps (UL)
GSM Features	<ul style="list-style-type: none"> ● GPRS: <ul style="list-style-type: none"> – Supports GPRS multi-slot class 33 (33 by default) – Coding scheme: CS 1–4 – Max. 107 kbps (DL), Max. 85.6 kbps (UL) ● EDGE: <ul style="list-style-type: none"> – Supports EDGE multi-slot class 33 (33 by default) – Supports GMSK and 8-PSK for different MCS (Modulation and Coding Scheme) – Downlink coding schemes: MCS 1–9 – Uplink coding schemes: MCS 1–9 – Max. 296 kbps (DL), Max. 236.8 kbps (UL)

Internet Protocol Features	<ul style="list-style-type: none"> ● Supports TCP/UDP/PPP/FTP/FTPS/HTTP/HTTPS/NTP/PING/QMI/NITZ/SMTP/SSL/MQTT/CMUX/SMTPS/FILE/MMS protocols ● Supports PAP and CHAP for PPP connections
SMS	<ul style="list-style-type: none"> ● Text and PDU modes ● Point-to-point MO and MT ● SMS cell broadcast ● SMS storage: ME by default
(U)SIM Interface	Supports USIM/SIM card: 1.8 V, 3.0 V
Audio Features	<ul style="list-style-type: none"> ● Supports one digital audio interface: PCM interface ● GSM: HR/FR/EFR/AMR/AMR-WB ● WCDMA: AMR/AMR-WB ● LTE: AMR/AMR-WB ● Supports echo cancellation and noise suppression
PCM Interface	<ul style="list-style-type: none"> ● Used for audio function with external codec ● Supports 16-bit linear data format ● Supports long frame synchronization and short frame synchronization ● Supports master and slave modes in short frame synchronization, and only supports master mode in long frame synchronization
USB Interface	<ul style="list-style-type: none"> ● Compliant with USB 2.0 specification (slave only); the data transfer rate can reach up to 480 Mbps ● Used for AT command communication, data transmission, GNSS NMEA sentence output, software debugging, firmware upgrade and voice over USB ● Supports USB serial drivers for: Windows 7/8/8.1/10/11, Linux 2.6–5.18, Android 4.x–12.x, etc.
UART Interfaces	<ul style="list-style-type: none"> ● Main UART: <ul style="list-style-type: none"> – Used for AT command communication and data transmission – Baud rates reach up to 921600 bps, 115200 bps by default – Support RTS and CTS hardware flow control ● Debug UART: <ul style="list-style-type: none"> – Used for Linux console and log output – 115200bps baud rate
SD Card Interface	Supports SD 3.0 protocol
SGMII Interface	<ul style="list-style-type: none"> ● Supports 10/100/1000 Mbps Ethernet work mode ● Supports maximum 150 Mbps (DL)/50 Mbps (UL) for 4G network
Rx-diversity	Supports LTE/WCDMA Rx-diversity
GNSS Features	<ul style="list-style-type: none"> ● Protocol: NMEA 0183 ● Data update rate: 1 Hz by default
AT Commands	<ul style="list-style-type: none"> ● Compliant with 3GPP TS 27.007, 3GPP TS 27.005 ● Compliant with Quectel enhanced AT commands
Network Indication	<ul style="list-style-type: none"> ● Two pins NET_MODE and NET_STATUS to indicate network connectivity status

Antenna Interfaces	<ul style="list-style-type: none">● Main antenna interface (ANT_MAIN)● Rx-diversity antenna interface (ANT_DIV)● GNSS antenna interface (ANT_GNSS)
Physical Characteristics	<ul style="list-style-type: none">● Size: (29.0 ±0.2) mm × (32.0 ±0.2) mm × (2.4 ±0.2) mm● Package: LGA● Weight: approx. 4.9 g
Temperature Range	<ul style="list-style-type: none">● Operating temperature range: -35 °C to +75 °C ²● Extended temperature range: -40 °C to +85 °C ³● Storage temperature range: -40 °C to +90 °C
Firmware Upgrade	USB interface or DFOTA
RoHS	All hardware components are fully compliant with EU RoHS directive.

² Within operating temperature range, the module is 3GPP compliant.

³ Within the extended temperature range, the module remains the ability to establish and maintain functions such as voice, SMS, data transmission, etc., without any unrecoverable malfunction. Radio spectrum and radio network are not influenced, while one or more specifications, such as P_{out} , may exceed the specified tolerances of 3GPP. When the temperature returns to the operating temperature range, the module meets 3GPP specifications again.

2.3 Functional Diagram

The following figure shows a block diagram of EG25-GL and illustrates the major functional parts.

- Power management
- Baseband
- DDR2+NAND flash
- Radio frequency
- Peripheral interfaces

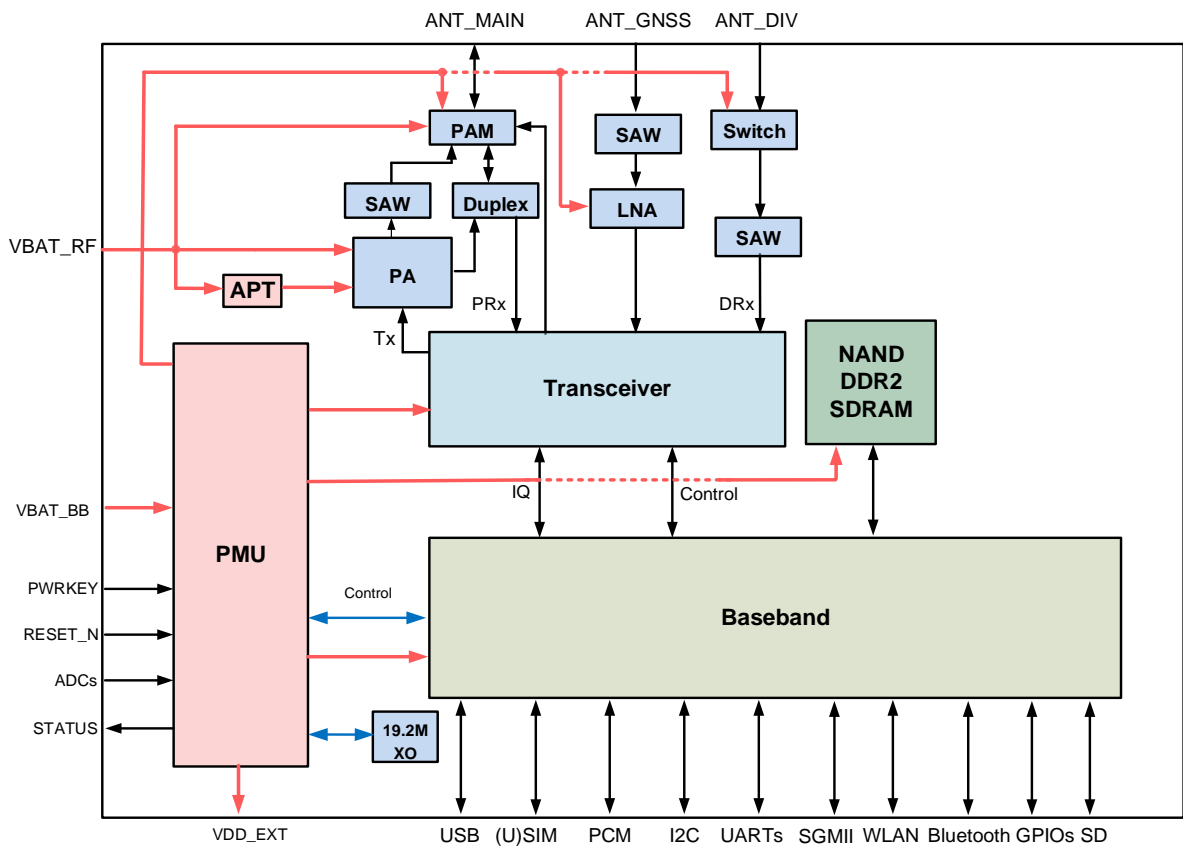

Figure 1: Functional Diagram

2.4 Pin Assignment

The following figure shows the pin assignment of EG25-GL module.

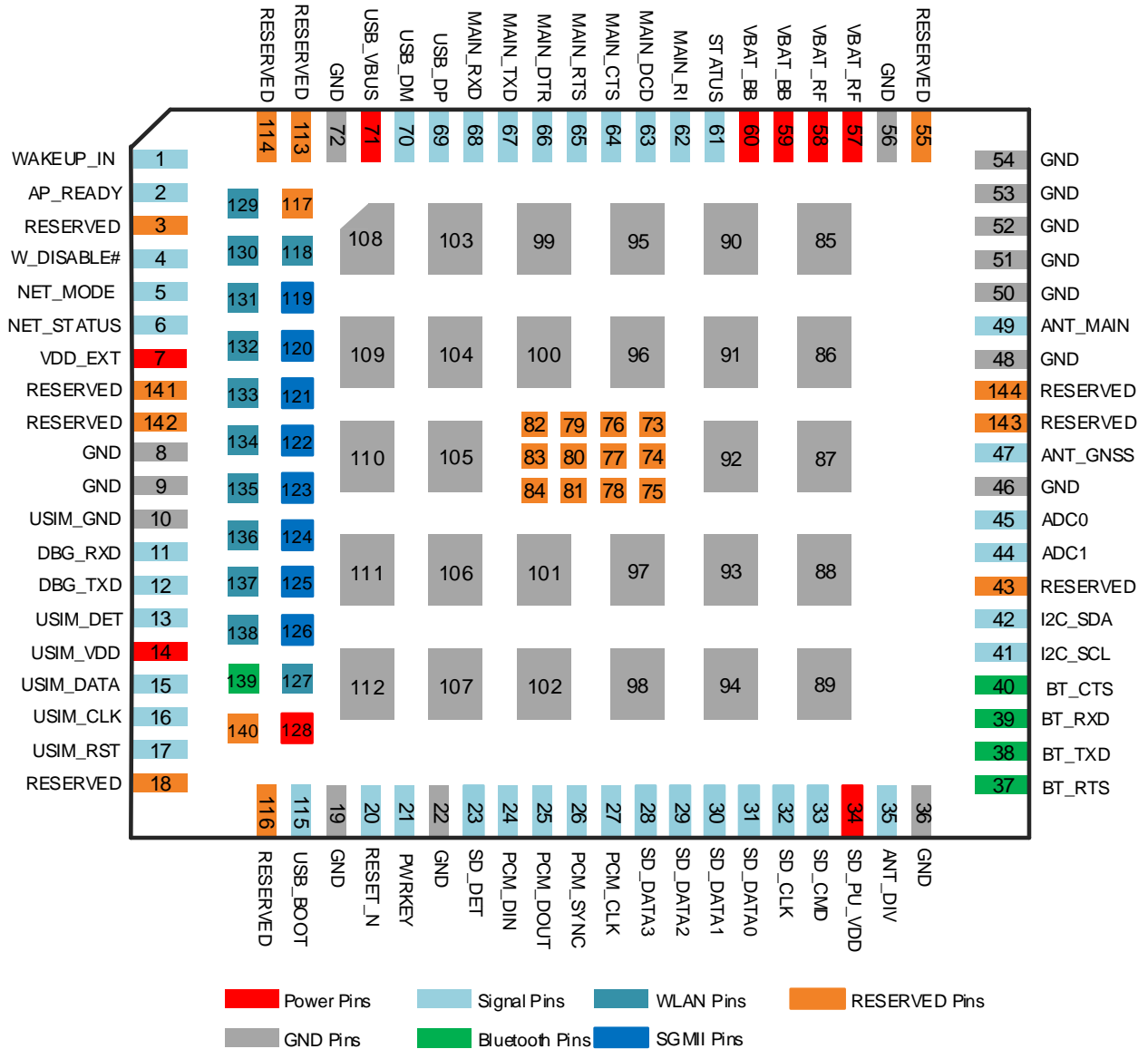

Figure 2: Pin Assignment (Top View)

NOTE

1. BOOT_CONFIG pins (WAKEUP_IN, NET_MODE, WLAN_EN, COEX_RXD, COEX_TXD, USB_BOOT and BT_CTS*) cannot be pulled up before startup.
2. PWRKEY output voltage is 0.8 V because of the diode drop in the baseband chipset.
3. USB_BOOT and COEX_RXD are connected inside the module and share the same network.

4. Pins 37–40, 118, 127 and 129–139 are used for WLAN & Bluetooth application interfaces, among which pins 118, 127 and 129–138 are WLAN function pins, and the rest are Bluetooth function* pins.
5. Pins 119–126 and 128 are used for SGMII interface.
6. Pins 24–27 of PCM interface can be used not only for audio function on EG25-GL module, but also for Bluetooth function* on FC20 series or FC21 module.
7. Keep all RESERVED pins and unused pins unconnected.
8. GND pin 85–112 should be connected to ground in the design. RESERVED pin 73–84 should not be designed in schematic and PCB decal, and these pins should be served as a keepout area.

2.5 Pin Description

The following tables show the pin definition of EG25-GL module. DC characteristics include power domain and rate current.

Table 4: I/O Parameters Definition

Type	Description
AI	Analog Input
AO	Analog Output
AIO	Analog Input/Output
DI	Digital Input
DO	Digital Output
DIO	Digital Input/Output
OD	Open Drain
PI	Power Input
PO	Power Output

Table 5: Pin Description

Power Supply					
Pin Name	Pin No.	I/O	Description	DC Characteristics	Comment
VBAT_BB	59, 60	PI	Power supply for the module's BB part	$V_{max} = 4.3\text{ V}$ $V_{min} = 3.3\text{ V}$ $V_{nom} = 3.8\text{ V}$	It must be provided with sufficient current up to 0.8 A.
VBAT_RF	57, 58	PI	Power supply for the module's RF part		It must be provided with sufficient current up to 1.8 A in a burst transmission.
VDD_EXT	7	PO	Provide 1.8 V for external circuit	$V_{nom} = 1.8\text{ V}$ $I_{o,max} = 50\text{ mA}$	Power supply for external GPIO's pull up circuits. If unused, keep it open.
GND	8, 9, 19, 22, 36, 46, 48, 50–54, 56, 72, 85–112				
Turn On/Off					
Pin Name	Pin No.	I/O	Description	DC Characteristics	Comment
PWRKEY	21	DI	Turn on/off the module		The output voltage is 0.8 V because of the diode drop in the chipset.
RESET_N	20	DI	Reset the module	$V_{IH,max} = 2.1\text{ V}$ $V_{IH,min} = 1.3\text{ V}$ $V_{IL,max} = 0.5\text{ V}$	1.8 V power domain. If unused, keep it open.
Indication Signals					
Pin Name	Pin No.	I/O	Description	DC Characteristics	Comment
STATUS	61	OD	Indicate the module's operation status	VDD_EXT	The drive current should be less than 0.9 mA. An external pull-up resistor is required. If unused, keep it open.
NET_MODE	5	DO	Indicate the module's network registration mode	VDD_EXT	1.8 V power domain. Cannot be pulled up before startup. If unused, keep it open.

NET_STATUS	6	DO	Indicate the module's network activity status	VDD_EXT	1.8 V power domain. If unused, keep it open.
------------	---	----	---	---------	---

USB Interface

Pin Name	Pin No.	I/O	Description	DC Characteristics	Comment
USB_VBUS	71	PI	USB connection detect	Vmax = 5.25 V Vmin = 3.0 V Vnom = 5.0 V	Typical: 5.0 V If unused, keep it open.
USB_DP	69	AIO	USB 2.0 differential data (+)		USB 2.0 compliant. Require differential impedance of 90 Ω.
USB_DM	70	AIO	USB 2.0 differential data (-)		If unused, keep it open.

(U)SIM Interface

Pin Name	Pin No.	I/O	Description	DC Characteristics	Comment
USIM_GND	10	-	Specified ground for (U)SIM		
				I _o max = 50 mA	
USIM_VDD	14	PO	(U)SIM card power supply	Low-voltage: Vmax = 1.9 V Vmin = 1.7 V High-voltage: Vmax = 3.05 V Vmin = 2.7 V	Either 1.8 V or 3.0 V is supported by the module automatically.
USIM_DATA	15	DIO	(U)SIM card data	USIM_VDD	
USIM_CLK	16	DO	(U)SIM card clock	USIM_VDD	
USIM_RST	17	DO	(U)SIM card reset	USIM_VDD	
USIM_DET	13	DI	(U)SIM card hot-plug detect	VDD_EXT	1.8 V power domain. If unused, keep it open.

Main UART Interface

Pin Name	Pin No.	I/O	Description	DC Characteristics	Comment
MAIN_RI	62	DO	Main UART ring indication	VDD_EXT	1.8 V power domain. If unused, keep it

MAIN_DCD	63	DO	Main UART data carrier detect	VDD_EXT	open.
MAIN_CTS	64	DO	DTE clear to send signal from DCE	VDD_EXT	Connect to DTE's CTS. 1.8 V power domain. If unused, keep it open.
MAIN_RTS	65	DI	DTE request to send signal to DCE	VDD_EXT	Connect to DTE's RTS. 1.8 V power domain. If unused, keep it open.
MAIN_DTR	66	DI	Main UART data terminal ready	VDD_EXT	1.8 V power domain. Pulled up by default. The pin can wake up the module in the low level. If unused, keep it open.
MAIN_TXD	67	DO	Main UART transmit	VDD_EXT	1.8 V power domain. If unused, keep it open.
MAIN_RXD	68	DI	Main UART receive	VDD_EXT	open.

Debug UART Interface

Pin Name	Pin No.	I/O	Description	DC Characteristics	Comment
DBG_TXD	12	DO	Debug UART transmit	VDD_EXT	1.8 V power domain. If unused, keep it open.
DBG_RXD	11	DI	Debug UART receive	VDD_EXT	open.

ADC Interfaces

Pin Name	Pin No.	I/O	Description	DC Characteristics	Comment
ADC0	45	AI	General-purpose analog to digital converter	Voltage range: 0.3 V to VBAT_BB	If unused, keep it open.
ADC1	44	AI	General-purpose analog to digital converter		

PCM Interface ⁴

Pin Name	Pin No.	I/O	Description	DC Characteristics	Comment
PCM_DIN	24	DI	PCM data input	VDD_EXT	1.8 V power domain. If unused, keep it open.
PCM_DOUT	25	DO	PCM data output	VDD_EXT	
PCM_SYNC	26	DIO	PCM data frame sync	VDD_EXT	1.8 V power domain. In master mode, it is an output signal. In slave mode, it is an input signal. If unused, keep it open.
PCM_CLK	27	DIO	PCM clock	VDD_EXT	

I2C Interface

Pin Name	Pin No.	I/O	Description	DC Characteristics	Comment
I2C_SCL	41	OD	I2C serial clock (for external codec)	VDD_EXT	An external pull-up to 1.8 V is required. If unused, keep it open.
I2C_SDA	42	OD	I2C serial data (for external codec)	VDD_EXT	

SD Card Interface

Pin Name	Pin No.	I/O	Description	DC Characteristics	Comment
SD_DATA0	31	DIO	SDIO data bit 0	SD_PU_VDD	SDIO signal level can be selected according to SD card supported level, see SD 3.0 protocol for more details. If unused, keep it open.
SD_DATA1	30	DIO	SDIO data bit 1	SD_PU_VDD	
SD_DATA2	29	DIO	SDIO data bit 2	SD_PU_VDD	
SD_DATA3	28	DIO	SDIO data bit 3	SD_PU_VDD	
SD_CLK	32	DO	SD card clock	SD_PU_VDD	SDIO signal level can be selected according to SD card supported level, see SD 3.0 protocol for more details. If unused, keep it open.

⁴ Pins (Pin 24–27) of PCM interface can be used not only for audio function on EG25-GL module, but also for Bluetooth function* on FC20 series or FC21 module.

SD_CMD	33	DIO	SD card command	SD_PU_VDD	SDIO signal level can be selected according to SD card supported level, see SD 3.0 protocol for more details. If unused, keep it open.
SD_DET	23	DI	SD card insertion detect	VDD_EXT	1.8 V power domain. If unused, keep it open.
SD_PU_VDD	34	PO	1.8/2.85 V output power for SD card pull-up circuits	I _o max = 50 mA	Cannot be used for SD card power. If unused, keep it open.

WLAN & Bluetooth Application Interfaces

Pin Name	Pin No.	I/O	Description	DC Characteristics	Comment
WLAN_SLP_CLK	118	DO	WLAN sleep clock		If unused, keep it open.
WLAN_PWR_EN	127	DO	WLAN power supply enable control	VDD_EXT	1.8 V power domain. Active high. If unused, keep it open.
SDC_DATA0	132	DIO	WLAN SDIO data bit 0	VDD_EXT	
SDC_DATA1	131	DIO	WLAN SDIO data bit 1	VDD_EXT	
SDC_DATA2	130	DIO	WLAN SDIO data bit 2	VDD_EXT	1.8 V power domain. If unused, keep it open.
SDC_DATA3	129	DIO	WLAN SDIO data bit 3	VDD_EXT	
SDC_CLK	133	DO	WLAN SDIO clock	VDD_EXT	
SDC_CMD	134	DO	WLAN SDIO command	VDD_EXT	
WAKE_ON_WIRELESS	135	DI	Wi-Fi/Bluetooth wakeup signal to the module	VDD_EXT	FC20 series or FC21 module wakes up the module. 1.8 V power domain. Active low. If unused, keep it open.

WLAN_EN	136	DO	WLAN function enable control	VDD_EXT	1.8 V power domain. Active high. Cannot be pulled up before startup. If unused, keep it open.
COEX_RXD	137	DI	LTE & WLAN/ Bluetooth coexistence receive	VDD_EXT	1.8 V power domain. Cannot be pulled up before startup. If unused, keep it open.
COEX_TXD	138	DO	LTE & WLAN/ Bluetooth coexistence transmit	VDD_EXT	1.8 V power domain. Cannot be pulled up before startup. If unused, keep it open.
BT_RTS*	37	DI	DTE request to send signal to DCE	VDD_EXT	Connect to DTE's RTS. 1.8 V power domain. If unused, keep it open.
BT_TXD*	38	DO	Bluetooth UART transmit	VDD_EXT	1.8 V power domain. If unused, keep it open.
BT_RXD*	39	DI	Bluetooth UART receive	VDD_EXT	1.8 V power domain. If unused, keep it open.
BT_CTS*	40	DO	DTE clear to send signal from DCE	VDD_EXT	Connect to DTE's CTS. 1.8 V power domain. Cannot be pulled up before startup. If unused, keep it open.
BT_EN*	139	DO	Bluetooth enable control	VDD_EXT	1.8 V power domain. If unused, keep it open.

SGMII Interface

Pin Name	Pin No.	I/O	Description	DC Characteristics	Comment
SGMII_RST_N	119	DO	Ethernet PHY reset	SGMII_MDIO_VDD	1.8/2.85 V power domain. If unused, keep it open.
SGMII_INT_N	120	DI	Ethernet PHY interrupt	VDD_EXT	1.8 V power domain. If unused, keep it open.
SGMII_MDIO	121	DIO	SGMII management data	SGMII_MDIO_VDD	1.8/2.85 V power domain.

					Require external pull-up to SGMII_MDIO_VDD, and the resistor should be 1.5 kΩ. If unused, keep it open.
SGMII_MDC	122	DO	SGMII management data clock	SGMII_MDIO_VDD	1.8/2.85 V power domain. If unused, keep it open.
SGMII_TX_M	123	AO	SGMII transmit (-)		Connect with a 0.1 μF capacitor, which is close to the two pins of the module. If unused, keep it open.
SGMII_TX_P	124	AO	SGMII transmit (+)		
SGMII_RX_P	125	AI	SGMII receive (+)		
SGMII_RX_M	126	AI	SGMII receive (-)		
SGMII_MDIO_VDD	128	PO	SGMII_MDIO pull up power supply	I _o max = 50 mA	Configurable power source. 1.8/2.85 V power domain. If unused, keep it open.

Antenna Interfaces

Pin Name	Pin No.	I/O	Description	DC Characteristics	Comment
ANT_DIV	35	AI	Diversity antenna interface		50 Ω impedance. If unused, keep it open.
ANT_MAIN	49	AIO	Main antenna interface		50 Ω impedance.
ANT_GNSS	47	AI	GNSS antenna interface		50 Ω impedance. If unused, keep it open.

Other Interface Pins

Pin Name	Pin No.	I/O	Description	DC Characteristics	Comment
WAKEUP_IN	1	DI	External wakeup signal to the module	VDD_EXT	1.8 V power domain. Cannot be pulled up before startup. The pin can wake up

					the module in the low level. If unused, keep it open.
W_DISABLE#	4	DI	Airplane mode control	VDD_EXT	1.8 V power domain. Pull-up by default. At low voltage level, module can enter into airplane mode. If unused, keep it open.
AP_READY	2	DI	Application processor ready	VDD_EXT	1.8 V power domain. If unused, keep it open.
USB_BOOT	115	DI	Force the module into emergency download mode	VDD_EXT	1.8 V power domain. Cannot be pulled up before startup. It is recommended to reserve test point.

RESERVED Pins

Pin Name	Pin No.	Comment
RESERVED	3, 18, 43, 55, 73–84, 113, 114, 116, 117, 140–144	Keep these pins unconnected.

2.6 EVB Kit

To help you develop applications with the module, Quectel supplies an evaluation board (UMTS<E EVB) with accessories to control or test the module. For more details, see **document [1]**.

3 Operating Characteristics

3.1 Operating Modes

The following table briefly outlines the operating modes to be mentioned in the following chapters.

Table 6: Overview of Operating Modes

Mode	Details	
Full Functionality Mode	Idle	Software is active. The module has registered on the network, and it is ready to send and receive data.
	Voice/Data	Network connection is ongoing. In this mode, the power consumption is decided by network setting and data transfer rate.
Minimum Functionality Mode	AT+CFUN=0 can set the module to a minimum functionality mode without removing the power supply. In this case, both RF function and (U)SIM card will be invalid.	
Airplane Mode	AT+CFUN=4 or W_DISABLE# pin can set the module to enter airplane mode. In this case, RF function will be invalid.	
Sleep Mode	The current consumption of the module will be reduced to the minimal level. During this mode, the module can still receive paging message, SMS, voice call and TCP/UDP data from the network normally.	
Power Down Mode	The power management unit shuts down the power supply. Software goes inactive. The serial interface is not accessible. Operating voltage (connected to VBAT_RF and VBAT_BB) remains applied.	

NOTE

See *document [2]* for details of **AT+CFUN**.

3.2 Sleep Mode

3.2.1 UART Application Scenario

If the host communicates with module via UART interfaces, the following preconditions can let the module enter sleep mode.

- Execute **AT+QSCLK=1** to enable sleep mode. For details of the command, see **document [2]**.
- Drive MAIN_DTR to high level.

The following figure shows the connection between the module and the host.

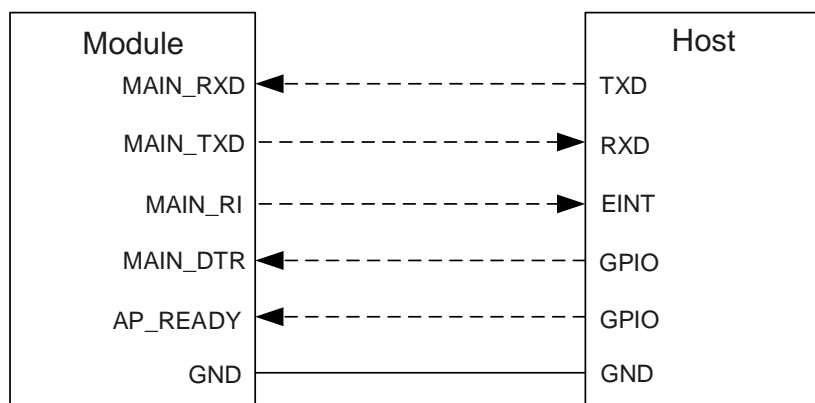

Figure 3: Sleep Mode Application via UART

- Driving the host MAIN_DTR to low level will wake up the module.
- When the module has a URC to report, MAIN_RI will wake up the host. See **Chapter 4.9.3** for details about MAIN_RI behaviors.
- AP_READY will detect the sleep state of the host (It can be configured to high level or low level detection). See **document [3]** for details about **AT+QCFG="apready"**.

3.2.2 USB Application Scenario

3.2.2.1 USB Application with USB Remote Wakeup Function

If the host supports USB suspend/resume and remote wakeup functions, the following three preconditions must be met to set the module to sleep mode.

- Execute **AT+QSCLK=1** to enable sleep mode.
- Ensure the MAIN_DTR is held at high level or keep it open.
- The host's USB bus, which is connected with the module's USB interface, enters suspend state.

The following figure shows the connection between the module and the host.

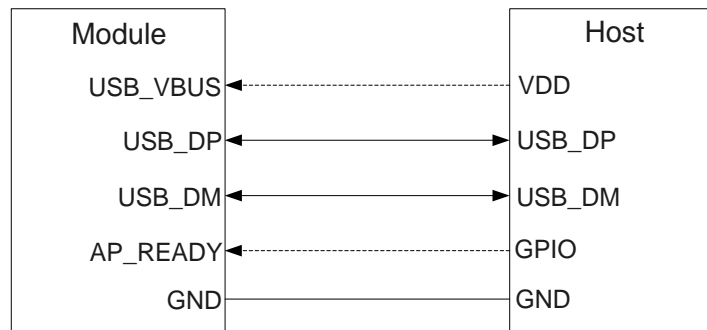

Figure 4: Sleep Mode Application with USB Remote Wakeup

- Sending data to the module through USB will wake up the module.
- When the module has a URC to report, it will send remote wake-up signals via USB bus to wake up the host.

3.2.2.2 USB Application with USB Suspend/Resume and MAIN_RI Function

If the host supports USB suspend and resume, but does not support remote wakeup function, MAIN_RI signal is needed to wake up the host.

There are three preconditions to set the module to sleep mode.

- Execute **AT+QSCCLK=1** to enable the sleep mode.
- Ensure the MAIN_DTR is held at high level or keep it open.
- The host’s USB bus, which is connected with the module’s USB interface, enters suspend state.

The following figure shows the connection between the module and the host.

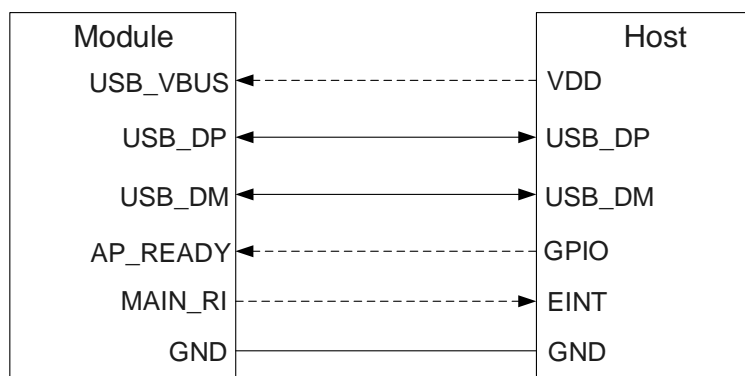

Figure 5: Sleep Mode Application with MAIN_RI

- Sending data to the module via USB will wake up the module.
- When the module has a URC to report, MAIN_RI signal will wake up the host.

3.2.2.3 USB Application without USB Suspend Function

If the host does not support USB suspend function, USB_VBUS should be disconnected with an external control circuit to set the module to sleep mode.

- Execute **AT+QSCCLK=1** to enable sleep mode.
- Ensure the MAIN_DTR is held at high level or keep it open.
- Disconnect USB_VBUS.

The following figure shows the connection between the module and the host.

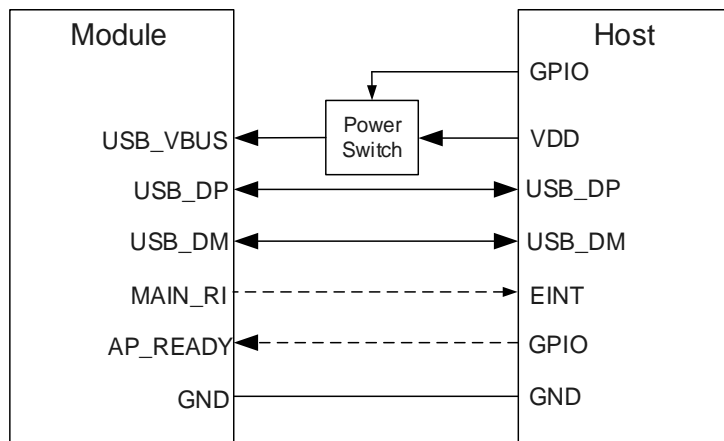

Figure 6: Sleep Mode Application without Suspend Function

Switching on the power switch to supply power to USB_VBUS will wake up the module.

NOTE

Pay attention to the level match shown in dotted line between the module and the host. For more details about the module power management application, see **document [4]**.

3.2.3 Airplane Mode

When the module enters airplane mode, the RF function will be disabled, and all AT commands related to it will be inaccessible. This mode can be set via the following ways.

Hardware:

The W_DISABLE# pin is pulled up by default. Driving it to low level will let the module enter airplane mode.

Software:

AT+CFUN provides the choice of the functionality level through setting **<fun>** into 0, 1 or 4.

- **AT+CFUN=0:** Minimum functionality mode. Both (U)SIM and RF functions are disabled.
- **AT+CFUN=1:** Full functionality mode (by default).
- **AT+CFUN=4:** Airplane mode. RF function is disabled.

NOTE

1. The W_DISABLE# control function is disabled in firmware by default. It can be enabled by **AT+QCFG="airplanecontrol"**.
2. The execution of **AT+CFUN** will not affect GNSS function.

3.3 Power Supply

3.3.1 Power Supply Pins

The module provides four VBAT pins for connection with the external power supply. There are two separate voltage domains for VBAT.

- Two VBAT_RF pins for module’s RF part
- Two VBAT_BB pins for module’s BB part

The following table shows the details of VBAT pins and ground pins.

Table 7: Pin Definition of VBAT and GND Pins

Pin Name	Pin No.	Description	Min.	Typ.	Max.	Unit
VBAT_BB	59, 60	Power supply for module’s BB part	3.3	3.8	4.3	V
VBAT_RF	57, 58	Power supply for module’s RF part	3.3	3.8	4.3	V
GND	8, 9, 19, 22, 36, 46, 48, 50–54, 56, 72, 85–112					

3.3.2 Voltage Stability Requirements

The power supply range of the module is from 3.3 V to 4.3 V. Please make sure that the input voltage will never drop below 3.3 V. The following figure shows the voltage drop during burst transmission in 2G network. The voltage drop will be less in 3G and 4G networks.

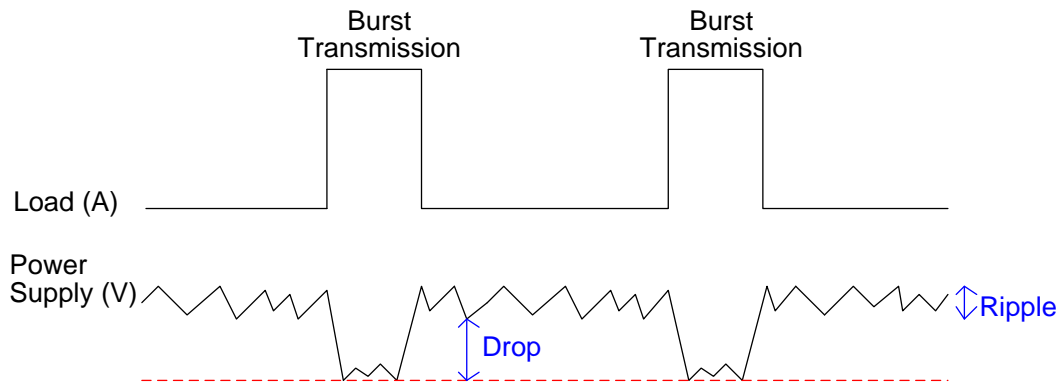

Figure 7: Power Supply Limits during Burst Transmission

To decrease voltage drop, a bypass capacitor of about 100 μF with low ESR ($\text{ESR} = 0.7 \Omega$) should be used for VBAT_BB and VBAT_RF respectively, and a multi-layer ceramic chip (MLCC) capacitor array should also be reserved due to its ultra-low ESR. It is recommended to use three ceramic capacitors (100 nF, 33 pF, 100 pF) for composing the MLCC array, and place these capacitors close to VBAT_BB and VBAT_RF. The main power supply from an external application has to be a single voltage source and can be expanded to two sub paths with star structure. The width of VBAT_BB trace should be not less than 1 mm; and the width of VBAT_RF trace should be not less than 2 mm. In principle, the longer the VBAT trace is, the wider it should be.

In addition, in order to avoid the damage caused by electric surge and electrostatics discharge (ESD), it is suggested that a TVS diode with suggested low reverse stand-off voltage $V_{\text{RWM}} 4.5 \text{ V}$, low clamping voltage V_{C} and high reverse peak pulse current I_{PP} should be used. The following figure shows the star structure of the power supply.

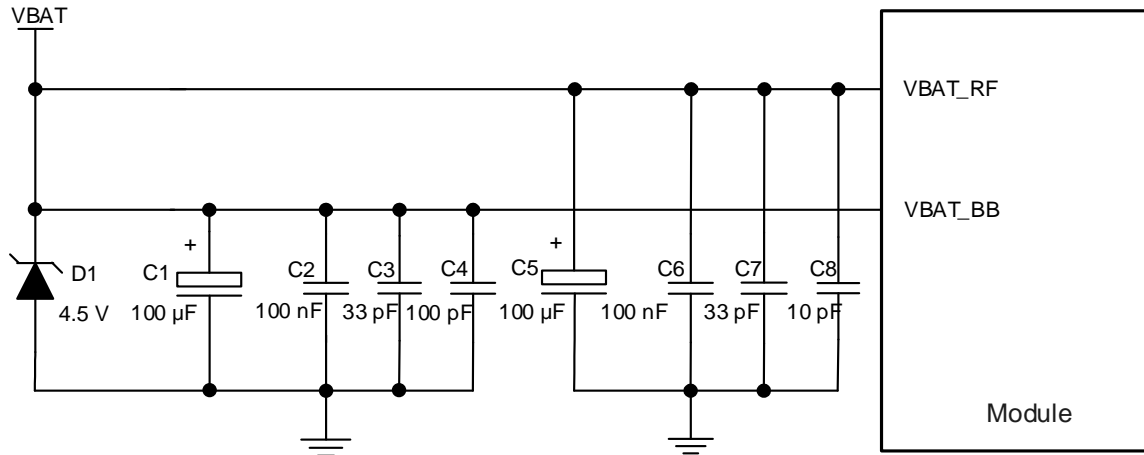

Figure 8: Star Structure of the Power Supply

3.3.3 Reference Design for Power Supply

Power design for the module is very important, as the performance of the module largely depends on the power source. The power supply should be able to provide sufficient current up to 2.0 A at least. If the voltage drop between the input and output is not too high, it is suggested that an LDO should be used to supply power for the module. If there is a big voltage difference between the input source and the desired output (VBAT), a buck converter is preferred to be used as the power supply.

The following figure shows a reference design for +5.0 V input power source. The typical output of the power supply is about 3.8 V and the maximum load current is 3.0 A.

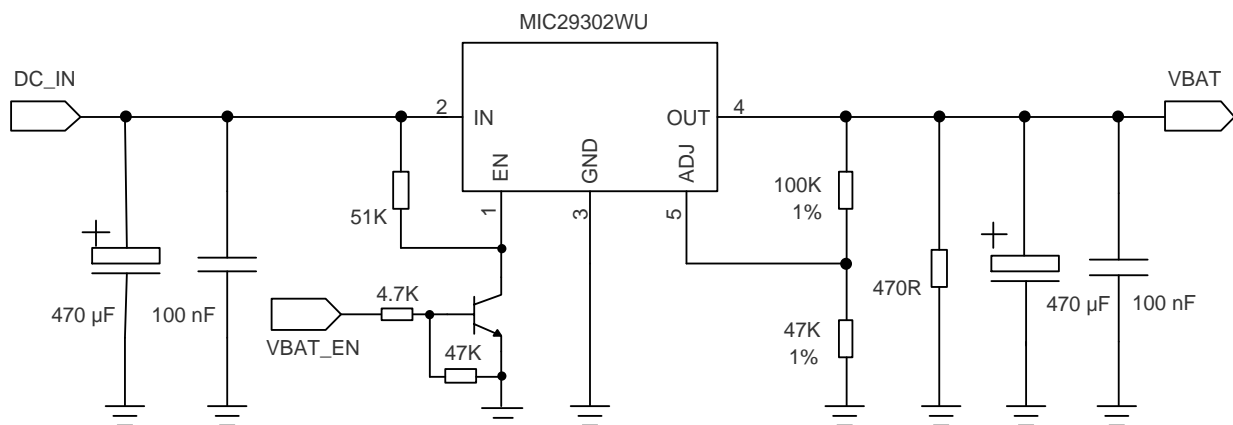

Figure 9: Reference Circuit of Power Supply

NOTE

To avoid corrupting the data in the internal flash, do not switch off the power supply when the module works normally. Only after shutting down the module with PWRKEY or AT command can you cut off the power supply.

3.3.4 Power Supply Voltage Monitoring

AT+CBC can be used to monitor the VBAT_BB voltage value. For more details, see *document [2]*.

3.4 Turn On

3.4.1 Turn On with PWRKEY

The following table shows the pin definition of PWRKEY.

Table 8: Pin Definition of PWRKEY

Pin Name	Pin No.	I/O	Description	Comment
PWRKEY	21	DI	Turn on/off the module	The output voltage is 0.8 V because of the diode drop in the chipset.

When the module is in power down mode, it can be turned on by driving PWRKEY low for at least 500 ms. It is recommended to use an open drain/collector driver to control the PWRKEY. After STATUS pin (requires external pull-up resistor) outputs a low level, PWRKEY pin can be released. A simple reference circuit is illustrated in the following figure.

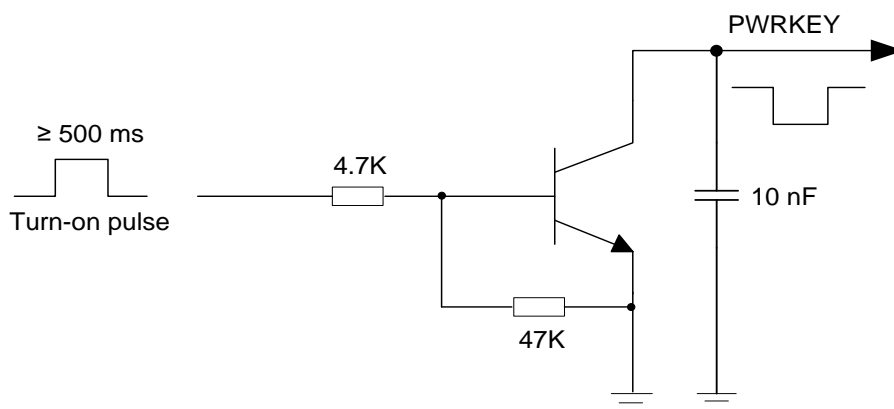

Figure 10: Turn On the Module by Using Driving Circuit

The other way to control the PWRKEY is using a button directly. When pressing the button, electrostatic strike may generate from finger. Therefore, a TVS component is indispensable to be placed nearby the button for ESD protection. A reference circuit is shown in the following figure.

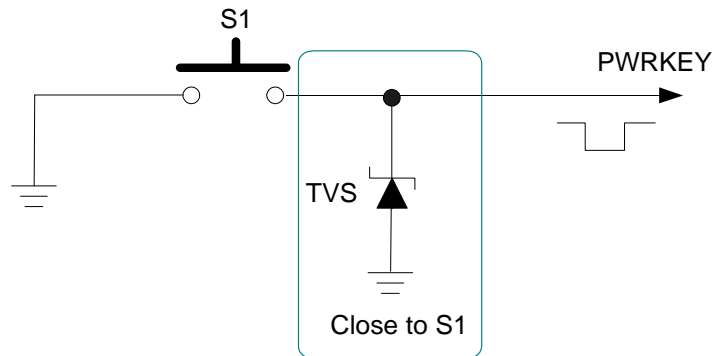

Figure 11: Turn On the Module by Using a Button

The power-up timing is illustrated in the following figure.

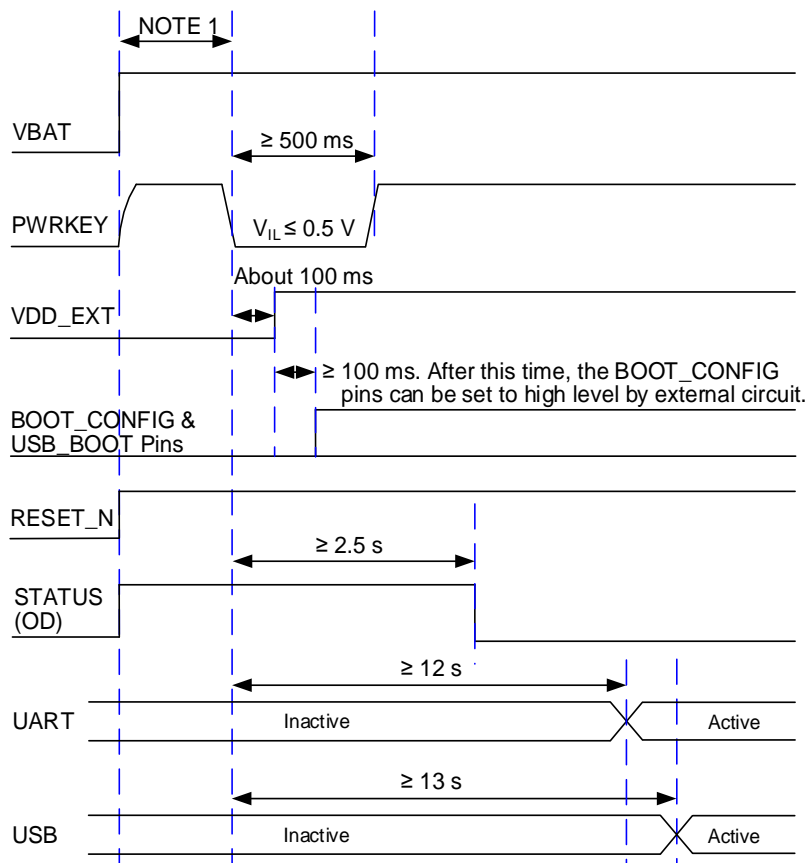

Figure 12: Power-up Timing

NOTE

1. Make sure that VBAT is stable before pulling down PWRKEY pin. It is recommended that the time between powering up VBAT and pulling down PWRKEY pin is not less than 30 ms.
2. PWRKEY can be pulled down directly to GND with a recommended 10 kΩ resistor if the module needs to be turned on automatically and shutdown is not needed.
3. BOOT_CONFIG pins (WAKEUP_IN, NET_MODE, WLAN_EN, COEX_RXD, COEX_TXD, USB_BOOT and BT_CTS*) cannot be pulled up before startup.
4. Ensure that there is no large capacitance on PWRKEY pin.

3.5 Turn Off

The following procedures can be used to turn off the module normally:

- Use the PWRKEY pin.
- Use **AT+QPOWD** command. For details of the command, see *document [2]*.

3.5.1 Turn Off with PWRKEY

Driving PWRKEY low for at least 650 ms, the module will execute power-off procedure after the PWRKEY is released. The power-down timing is illustrated in the following figure.

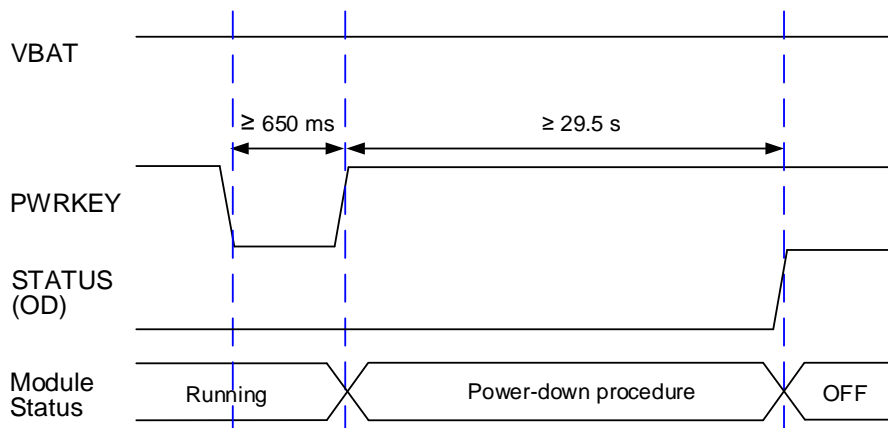

Figure 13: Power-down Timing

3.5.2 Turn Off with AT Command

It is also a safe way to use **AT+QPOWD** to turn off the module, which is similar to turning off the module via the PWRKEY pin.

NOTE

1. To avoid corrupting the data in the internal flash, do not switch off the power supply when the module works normally. Only after turning off the module with PWRKEY or AT command can you cut off the power supply.
2. When turning off module with the AT command, keep PWRKEY at high level after the execution of the command. Otherwise, the module will be turned on again after successfully turn-off.

3.6 Reset

The RESET_N pin can be used to reset the module. The module can be reset by driving RESET_N low for 150–460 ms.

Table 9: Pin Definition of RESET_N

Pin Name	Pin No.	I/O	Description	Comment
RESET_N	20	DI	Reset the module	1.8 V power domain. If unused, keep it open.

The recommended circuit is similar to the PWRKEY control circuit. An open drain/collector driver or button can be used to control the RESET_N.

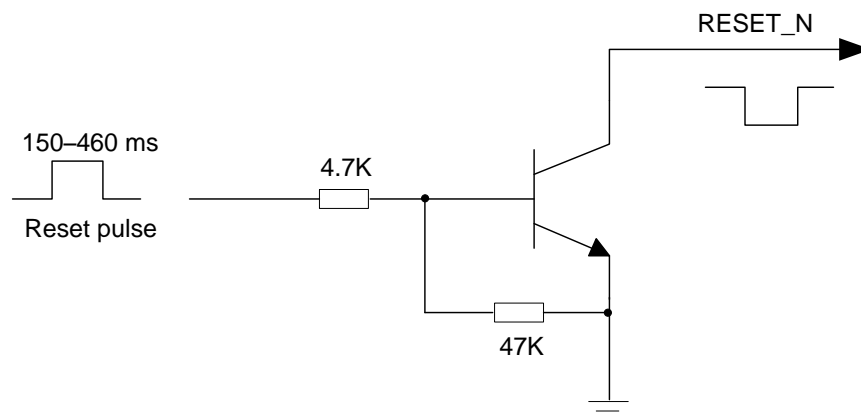

Figure 14: Reference Circuit of RESET_N by Using Driving Circuit

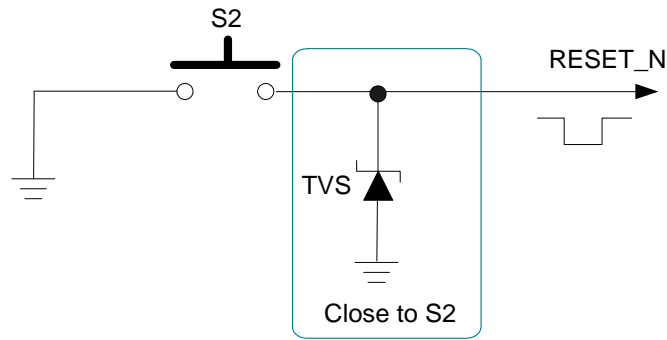

Figure 15: Reference Circuit of RESET_N by Using a Button

The reset scenario is illustrated in the following figure.

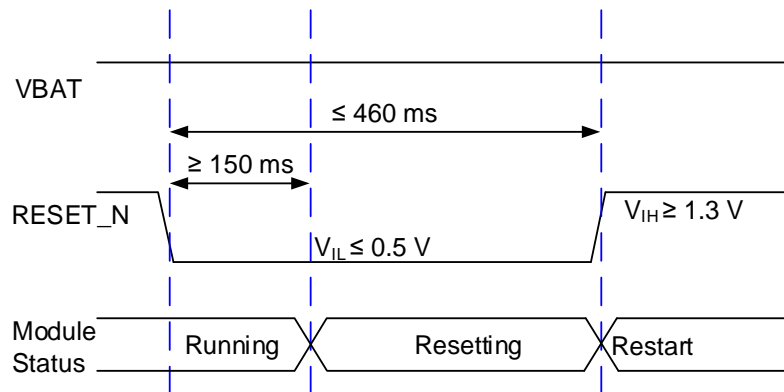

Figure 16: Reset Timing

NOTE

1. Use RESET_N only when failed to turn off the module by **AT+QPOWD** and PWRKEY pin.
2. Ensure that there is no large capacitance on RESET_N pin.

4 Application Interfaces

4.1 (U)SIM Interface

The (U)SIM interface circuitry meets ETSI and IMT-2000 requirements. Either 1.8 V or 3.0 V (U)SIM card is supported.

Table 10: Pin Definition of (U)SIM Interface

Pin Name	Pin No.	I/O	Description	Comment
USIM_VDD	14	PO	(U)SIM card power supply	Either 1.8 V or 3.0 V is supported by the module automatically.
USIM_DATA	15	DIO	(U)SIM card data	
USIM_CLK	16	DO	(U)SIM card clock	
USIM_RST	17	DO	(U)SIM card reset	
USIM_DET	13	DI	(U)SIM card hot-plug detect	1.8 V power domain. If unused, keep it open.
USIM_GND	10	-	Specified ground for (U)SIM	

The module supports (U)SIM card hot-plug via the USIM_DET pin, and both high and low level detection are supported. The function is disabled by default, and see **AT+QSIMDET** in **document [2]** for more details.

The following figure shows a reference design for (U)SIM interface with an 8-pin (U)SIM card connector.

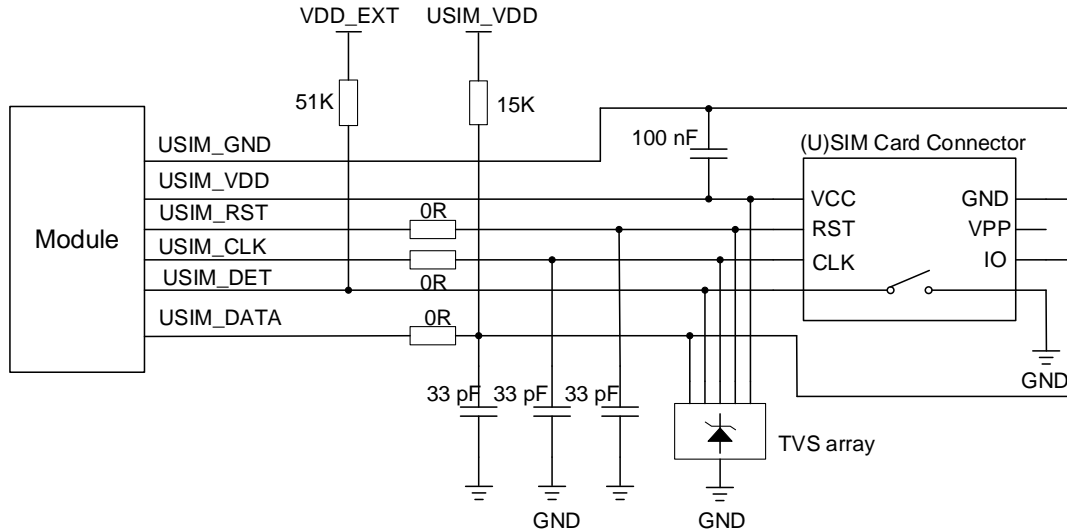

Figure 17: Reference Circuit of (U)SIM Interface with an 8-pin (U)SIM Card Connector

If (U)SIM card detection function is not needed, keep USIM_DET unconnected. A reference circuit of (U)SIM interface with a 6-pin (U)SIM card connector is illustrated in the following figure.

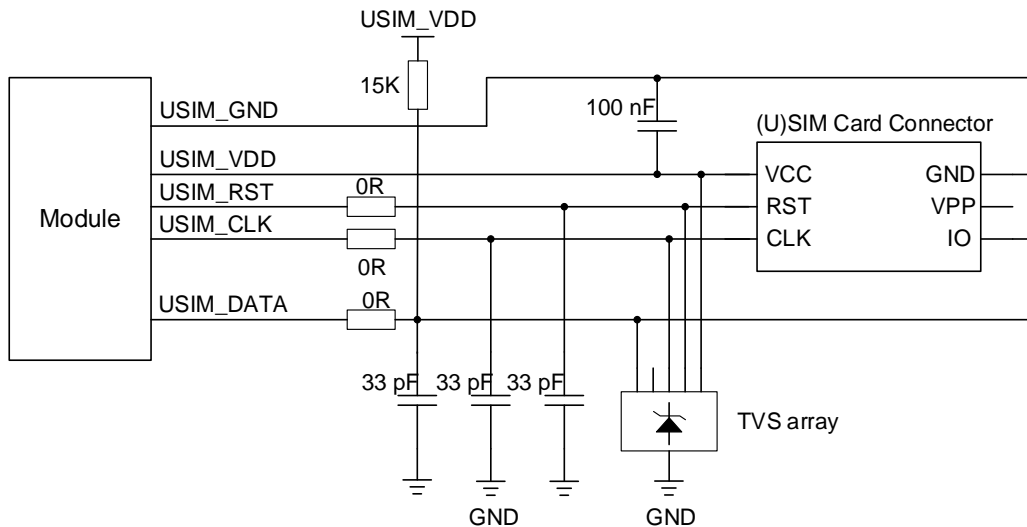

Figure 18: Reference Circuit of (U)SIM Interface with a 6-pin (U)SIM Card Connector

In order to enhance the reliability and availability of the (U)SIM card in your applications, please follow the criteria below in (U)SIM circuit design:

- Place the (U)SIM card connector as close to the module as possible. Keep the trace length as short as possible, at most 200 mm.
- Keep (U)SIM card signal traces away from RF and power supply traces.
- Make sure the bypass capacitor between USIM_VDD and USIM_GND less than 1 μ F, and place it as close to (U)SIM card connector as possible. If the ground is complete on your PCB, USIM_GND can

be connected to PCB ground directly.

- To avoid cross-talk between USIM_DATA and USIM_CLK, keep them away from each other and shield them with surrounded ground.
- In order to offer good ESD protection, it is recommended to add a TVS array whose parasitic capacitance should not be more than 15 pF. The 0 Ω resistors should be added in series between the module and the (U)SIM card to facilitate debugging. The 33 pF capacitors are used for filtering interference of EGSM900. Please note that the (U)SIM peripheral circuit should be close to the (U)SIM card connector.
- The pull-up resistor on USIM_DATA trace can improve anti-jamming capability when long layout trace and sensitive occasion are applied, and should be placed close to the (U)SIM card connector.

4.2 USB Interface

The module contains one integrated Universal Serial Bus (USB) interface which complies with the USB 2.0 specification and supports high-speed (480 Mbps) and full-speed (12 Mbps) modes. The USB interface can only serve as the slave device.

USB interface is used for AT command communication, data transmission, GNSS NMEA sentence output, software debugging, firmware upgrade and voice over USB.

The following table shows the pin definition of USB interface.

Table 11: Pin Definition of USB Interface

Pin Name	Pin No.	I/O	Description	Comment
USB_DP	69	AIO	USB 2.0 differential data (+)	USB 2.0 compliant. Require differential impedance of 90 Ω.
USB_DM	70	AIO	USB 2.0 differential data (-)	If unused, keep it open.
USB_VBUS	71	PI	USB connection	Typical 5.0 V
GND	72	-	Ground	

For more details about the USB 2.0 specifications, visit <http://www.usb.org/home>.

The USB interface is recommended to be reserved for firmware upgrade in your design. The following figure shows a reference circuit of USB interface.

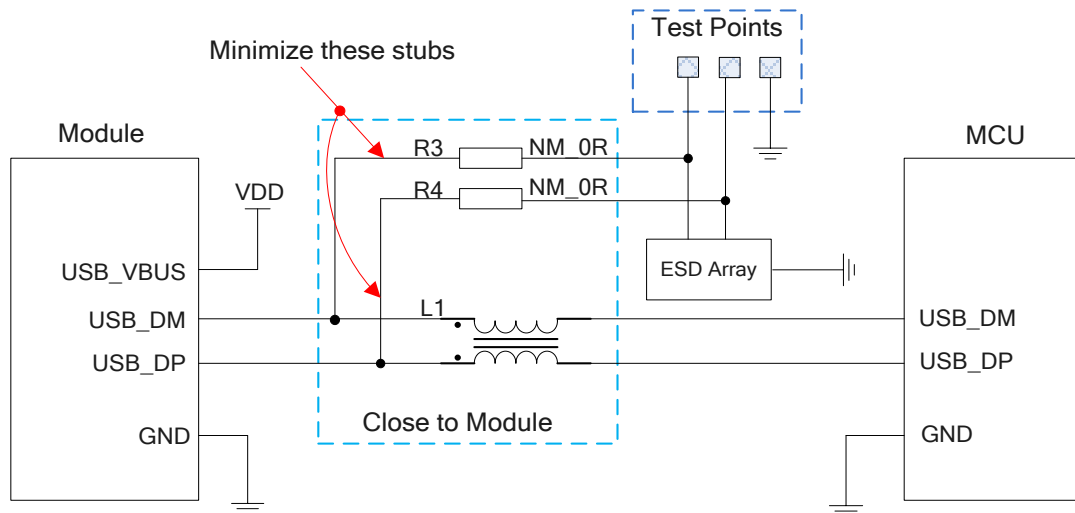

Figure 19: Reference Circuit of USB Interface

A common-mode choke L1 is recommended to be added in series between the module and your MCU to suppress EMI spurious transmission. Meanwhile, the 0 Ω resistors (R3 and R4) should be added in series between the module and the test points so as to facilitate debugging, and the resistors are not mounted by default. To ensure the integrity of USB data trace signal, L1/R3/R4 component must be placed close to the module, and also these resistors should be placed close to each other. The extra stubs of trace must be as short as possible.

The following principles should be complied with when design the USB interface, to meet USB 2.0 specification.

- It is important to route the USB signal traces as differential pairs with total grounding. The impedance of USB differential trace is 90 Ω.
- Do not route signal traces under crystals, oscillators, magnetic devices and RF signal traces. It is important to route the USB differential traces in inner-layer, and surround the traces with ground on that layer and with ground planes above and below.
- Junction capacitance of the ESD protection component might cause influences on USB data traces, so pay attention to the selection of the component. Typically, the stray capacitance should be less than 2 pF.
- Keep the ESD protection components to the USB connector as close as possible.

4.3 UART Interfaces

The module provides two UART interfaces: the main UART interface and the debug UART interface. The following shows their features.

- The main UART interface supports 4800, 9600, 19200, 38400, 57600, 115200, 230400, 460800 and

921600 bps baud rates, and the default is 115200 bps. It also supports RTS and CTS hardware flow control, and can be used for data transmission and AT command communication.

- The debug UART interface supports 115200 bps baud rate. It is used for Linux console and log output.

The following tables show the pin definition of the UART interfaces.

Table 12: Pin Definition of Main UART Interface

Pin Name	Pin No.	I/O	Description	Comment
MAIN_RI	62	DO	Main UART ring indication	1.8 V power domain.
MAIN_DCD	63	DO	Main UART data carrier detect	If unused, keep it open.
MAIN_CTS	64	DO	DTE clear to send signal from DCE	Connect to DTE's CTS. 1.8 V power domain. If unused, keep it open.
MAIN_RTS	65	DI	DTE request to send signal to DCE	Connect to DTE's RTS. 1.8 V power domain. If unused, keep it open.
MAIN_DTR	66	DI	Main UART data terminal ready	1.8 V power domain. Pulled up by default. The pin can wake up the module in the low level. If unused, keep it open.
MAIN_TXD	67	DO	Main UART transmit	1.8 V power domain.
MAIN_RXD	68	DI	Main UART receive	If unused, keep it open.

Table 13: Pin Definition of Debug UART Interface

Pin Name	Pin No.	I/O	Description	Comment
DBG_TXD	12	DO	Debug UART transmit	1.8 V power domain.
DBG_RXD	11	DI	Debug UART receive	If unused, keep it open.

The module provides 1.8 V UART interfaces. A level translator should be used if your application is equipped with a 3.3 V UART interface. A level translator TXS0108EPWR provided by Texas Instruments is recommended. The following figure shows a reference design.

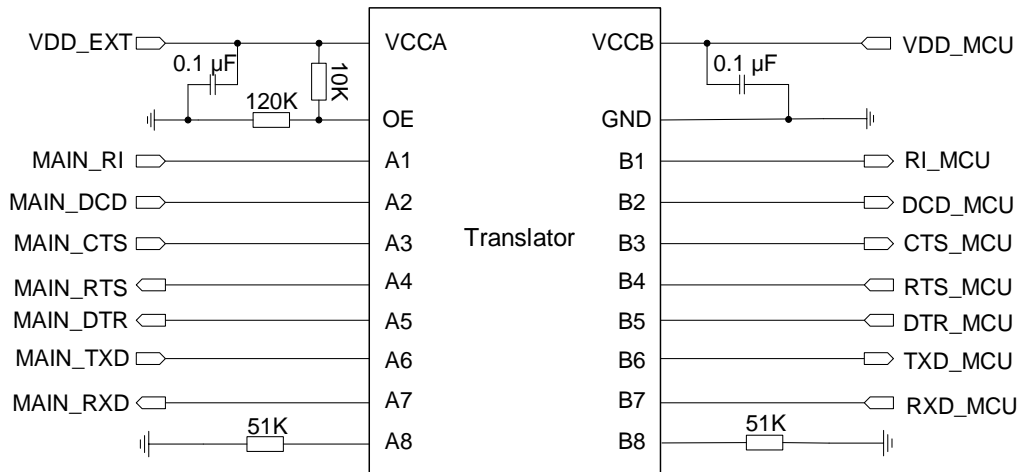

Figure 20: Reference Circuit with Translator Chip

Visit <http://www.ti.com> for more information.

Another example with transistor translation circuit is shown as below. For the design of circuits shown in dotted lines, see that shown in solid lines, but pay attention to the direction of connection.

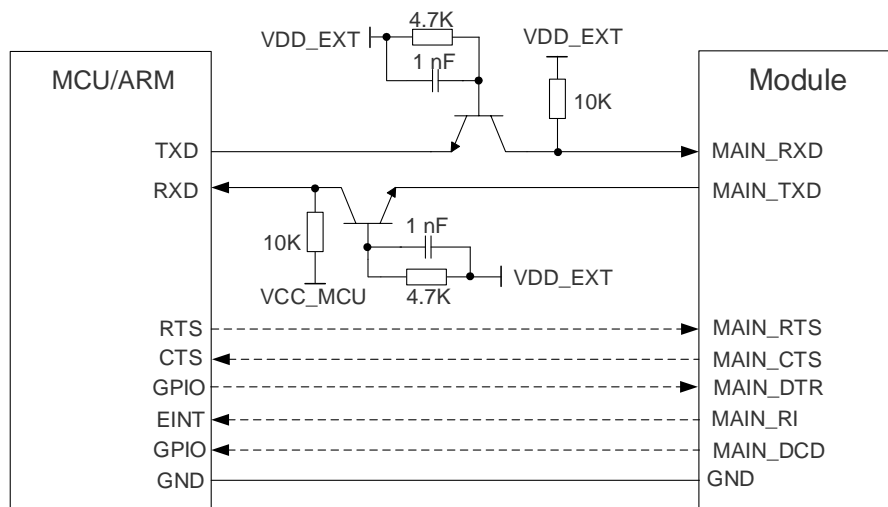

Figure 21: Reference Circuit with Transistor Circuit

NOTE

1. Transistor circuit solution is not suitable for applications with high baud rates exceeding 460 kbps.
2. Please note that the module's CTS is connected to the host's CTS, and the module's RTS is connected to the host's RTS.

4.4 PCM and I2C Interfaces

The module provides one Pulse Code Modulation (PCM) digital interface for audio design, which supports the following modes, and one I2C interface:

- Primary mode (short frame synchronization, works as both master and slave)
- Auxiliary mode (long frame synchronization, works as master only)

In primary mode, the data is sampled on the falling edge of the PCM_CLK and transmitted on the rising edge. The PCM_SYNC falling edge represents the MSB. In this mode, the PCM interface supports 256, 512, 1024 or 2048 kHz PCM_CLK at 8 kHz PCM_SYNC, and also supports 4096 kHz PCM_CLK at 16 kHz PCM_SYNC.

In auxiliary mode, the data is sampled on the falling edge of the PCM_CLK and transmitted on the rising edge. The PCM_SYNC rising edge represents the MSB. In this mode, the PCM interface operates with a 256, 512, 1024 or 2048 kHz PCM_CLK and an 8 kHz, 50% duty cycle PCM_SYNC.

The module supports 16-bit linear data format. The following figures show the primary mode's timing relationship with 8 kHz PCM_SYNC and 2048 kHz PCM_CLK, as well as the auxiliary mode's timing relationship with 8 kHz PCM_SYNC and 256 kHz PCM_CLK.

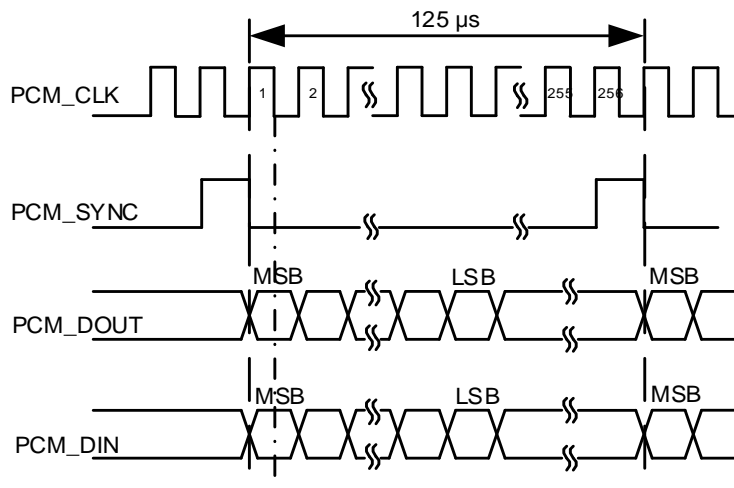

Figure 22: Primary Mode Timing

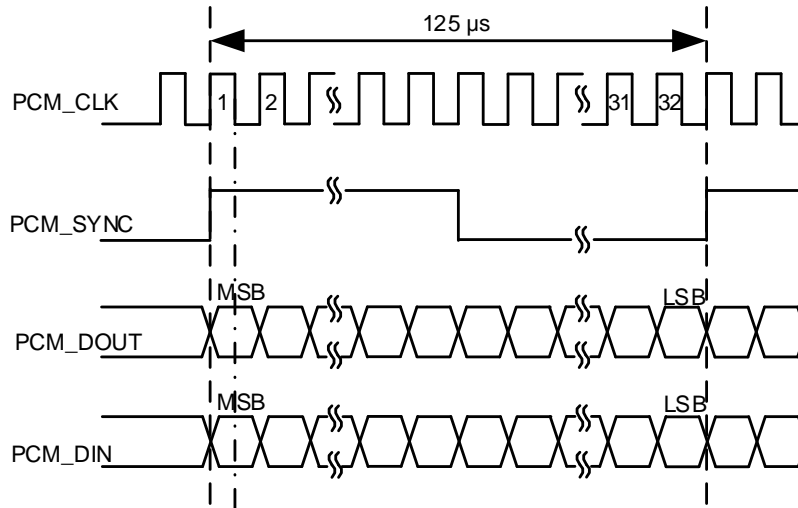

Figure 23: Auxiliary Mode Timing

The following table shows the pin definition of PCM and I2C interfaces which can be applied on audio codec design.

Table 14: Pin Definition of PCM and I2C Interfaces

Pin Name	Pin No.	I/O	Description	Comment
PCM_DIN	24	DI	PCM data input	1.8 V power domain.
PCM_DOUT	25	DO	PCM data output	If unused, keep it open.
PCM_SYNC	26	DIO	PCM data frame sync	1.8 V power domain. In master mode, it is an output signal.
PCM_CLK	27	DIO	PCM clock	In slave mode, it is an input signal. If unused, keep it open.
I2C_SCL	41	OD	I2C serial clock (for external codec)	An external pull-up to 1.8 V is required.
I2C_SDA	42	OD	I2C serial data (for external codec)	If unused, keep it open.

Clock and mode can be configured by AT command, and the default configuration is master mode using short frame synchronization format with 2048 kHz PCM_CLK and 8 kHz PCM_SYNC. See **document [2]** for more details about **AT+QDAI**.

The following figure shows a reference design of PCM and I2C interfaces with external codec IC.

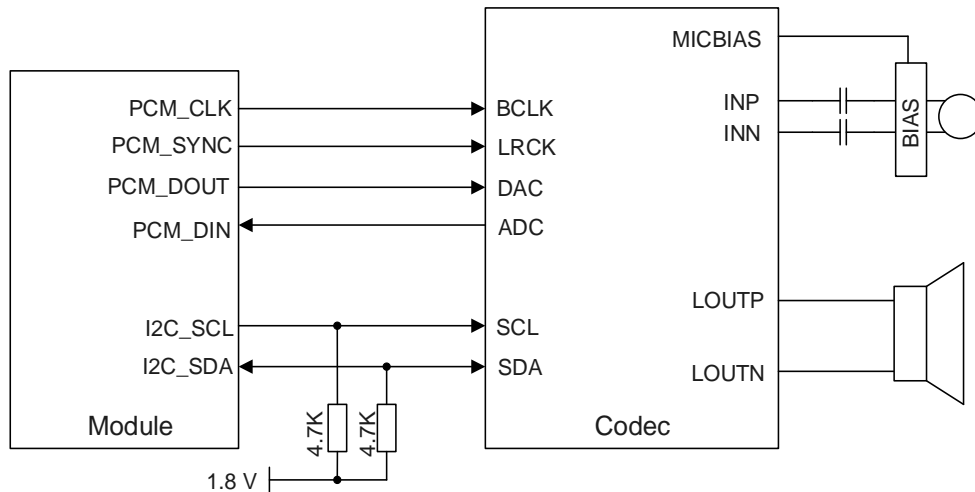

Figure 24: Reference Circuit of PCM and I2C Application with Audio Codec

NOTE

1. It is recommended to reserve an RC (R = 22 Ω, C = 22 pF) circuits on the PCM lines, especially for PCM_CLK.
2. The module works as a master device pertaining to I2C interface.

4.5 SD Card Interface

The module supports SDIO 3.0 interface for SD card. The following table shows the pin definition of SD card interface.

Table 15: Pin Definition of SD Card Interface

Pin Name	Pin No.	I/O	Description	Comment
SD_DATA0	31	DIO	SDIO data bit 0	SDIO signal level can be selected according to SD card supported level, see SD 3.0 protocol for more details. If unused, keep it open.
SD_DATA1	30	DIO	SDIO data bit 1	
SD_DATA2	29	DIO	SDIO data bit 2	
SD_DATA3	28	DIO	SDIO data bit 3	
SD_CLK	32	DO	SD card clock	SDIO signal level can be selected according to SD card supported level, see SD 3.0 protocol for more details. If unused, keep it open.

SD_CMD	33	DIO	SD card command	SDIO signal level can be selected according to SD card supported level, see SD 3.0 protocol for more details. If unused, keep it open.
SD_DET	23	DI	SD card insertion detect	1.8 V power domain. If unused, keep it open.
SD_PU_VDD	34	PO	1.8/2.85 V output power for SD card pull-up circuits	Cannot be used for SD card power. If unused, keep it open.

The following figure shows a reference design of SD card.

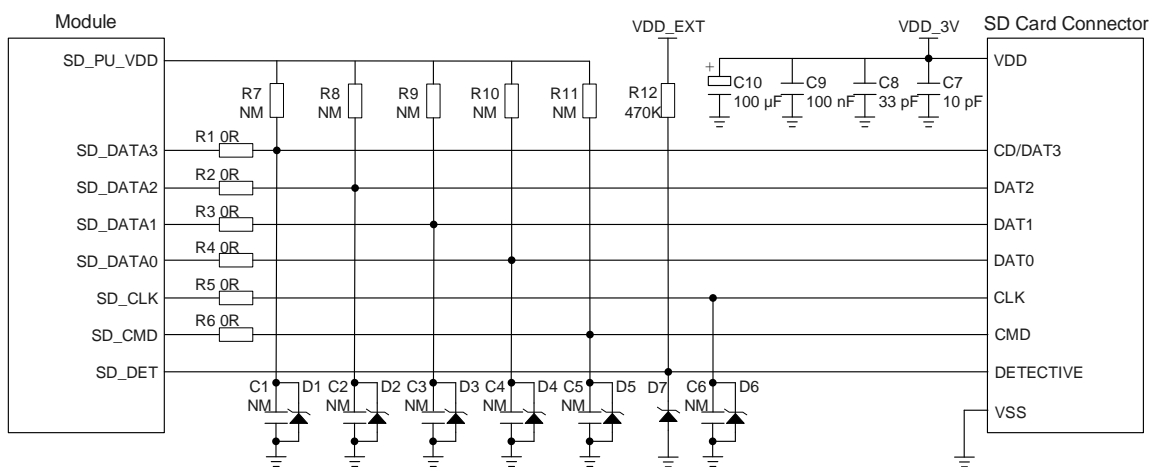

Figure 25: Reference Circuit of SD Card Interface

In SD card interface design, in order to ensure good communication performance with SD card, the following design principles should be complied with:

- SD_DET must be connected.
- The voltage range of SD card power supply VDD_3V is 2.7–3.6 V and a sufficient current up to 0.8 A should be provided. As the maximum output current of SD_PU_VDD is 50 mA which can only be used for SDIO pull-up resistors, an externally power supply is needed for SD card.
- To avoid jitter of bus, resistors R7–R11 are needed to pull up the SDIO to SD_PU_VDD. Value of these resistors is among 10–100 kΩ and the recommended value is 100 kΩ. SD_PU_VDD should be used as the pull-up power.
- In order to adjust signal quality, it is recommended to add 0 Ω resistors R1–R6 in series between the module and the SD card. The bypass capacitors C1–C6 are reserved and not mounted by default. All resistors and bypass capacitors should be placed close to the module.
- In order to offer good ESD protection, it is recommended to add a TVS diode on SD card pins near the SD card connector with junction capacitance less than 15 pF.
- Keep SDIO signals far away from other sensitive circuits/signals such as RF circuits, analog signals, etc., as well as noisy signals such as clock signals, DC-DC signals, etc.

- It is important to route the SDIO signal traces with total grounding. The impedance of SDIO data trace is 50 Ω (±10%).
- Make sure the adjacent trace spacing is twice of the trace width and the load capacitance of SDIO bus should be less than 15 pF.
- It is recommended to keep the trace length difference between SD_CLK and SD_DATA[0:3]/SD_CMD less than 1mm and the total routing length less than 50 mm. The total trace length inside the module is 27 mm, so the exterior total trace length should be less than 23 mm.

4.6 WLAN and Bluetooth Application Interfaces

The module supports a SDIO 3.0 interface for WLAN function, and UART and PCM interfaces for Bluetooth function*. The following table shows the pin definition of WLAN and Bluetooth application interfaces.

Table 16: Pin Definition of WLAN & Bluetooth Application Interfaces

Pin Name	Pin No.	I/O	Description	Comment
WLAN Application Interfaces				
SDC_DATA0	132	DIO	WLAN SDIO data bit 0	
SDC_DATA1	131	DIO	WLAN SDIO data bit 1	
SDC_DATA2	130	DIO	WLAN SDIO data bit 2	1.8 V power domain. If unused, keep it open.
SDC_DATA3	129	DIO	WLAN SDIO data bit 3	
SDC_CLK	133	DO	WLAN SDIO clock	
SDC_CMD	134	DO	WLAN SDIO command	
WLAN_EN	136	DO	WLAN function enable control	1.8 V power domain. Active high. Cannot be pulled up before startup. If unused, keep it open.
Coexistence and Control Interfaces				
WLAN_SLP_CLK	118	DO	WLAN sleep clock	If unused, keep it open.
WLAN_PWR_EN	127	DO	WLAN power supply enable control	1.8 V power domain. Active high. If unused, keep it open.
WAKE_ON_	135	DI	Wi-Fi/Bluetooth wakeup	FC20 series or FC21 module wakes

WIRELESS			signal to the module	up the module. 1.8 V power domain. Active low. If unused, keep it open.
COEX_RXD	137	DI	LTE & WLAN/ Bluetooth coexistence receive	1.8 V power domain.
COEX_TXD	138	DO	LTE & WLAN/ Bluetooth coexistence transmit	Cannot be pulled up before startup. If unused, keep it open.

Bluetooth Application Interfaces

BT_RTS*	37	DI	DTE request to send signal to DCE	Connect to DTE's RTS. 1.8 V power domain. If unused, keep it open.
BT_TXD*	38	DO	Bluetooth UART transmit	1.8 V power domain. If unused, keep it open.
BT_RXD*	39	DI	Bluetooth UART receive	1.8 V power domain. If unused, keep it open.
BT_CTS*	40	DO	DTE clear to send signal from DCE	Connect to DTE's CTS. 1.8 V power domain. Cannot be pulled up before startup. If unused, keep it open.
BT_EN*	139	DO	Bluetooth enable control	1.8 V power domain. If unused, keep it open.
PCM_DIN ⁵	24	DI	PCM data input	1.8 V power domain. If unused, keep it open.
PCM_DOUT ⁵	25	DO	PCM data output	1.8 V power domain. If unused, keep it open.
PCM_SYNC ⁵	26	DIO	PCM data frame sync	1.8 V power domain. In master mode, it is an output signal. In slave mode, it is an input signal. If unused, keep it open.
PCM_CLK ⁵	27	DIO	PCM clock	1.8 V power domain. In master mode, it is an output signal. In slave mode, it is an input signal. If unused, keep it open.

The following figure shows a reference design of WLAN and Bluetooth application interfaces with Quectel FC20 series or FC21 module.

⁵ Pins (Pin 24–27) of PCM interface can be used not only for audio function on EG25-GL module, but also for Bluetooth function* on FC20 series or FC21 module.

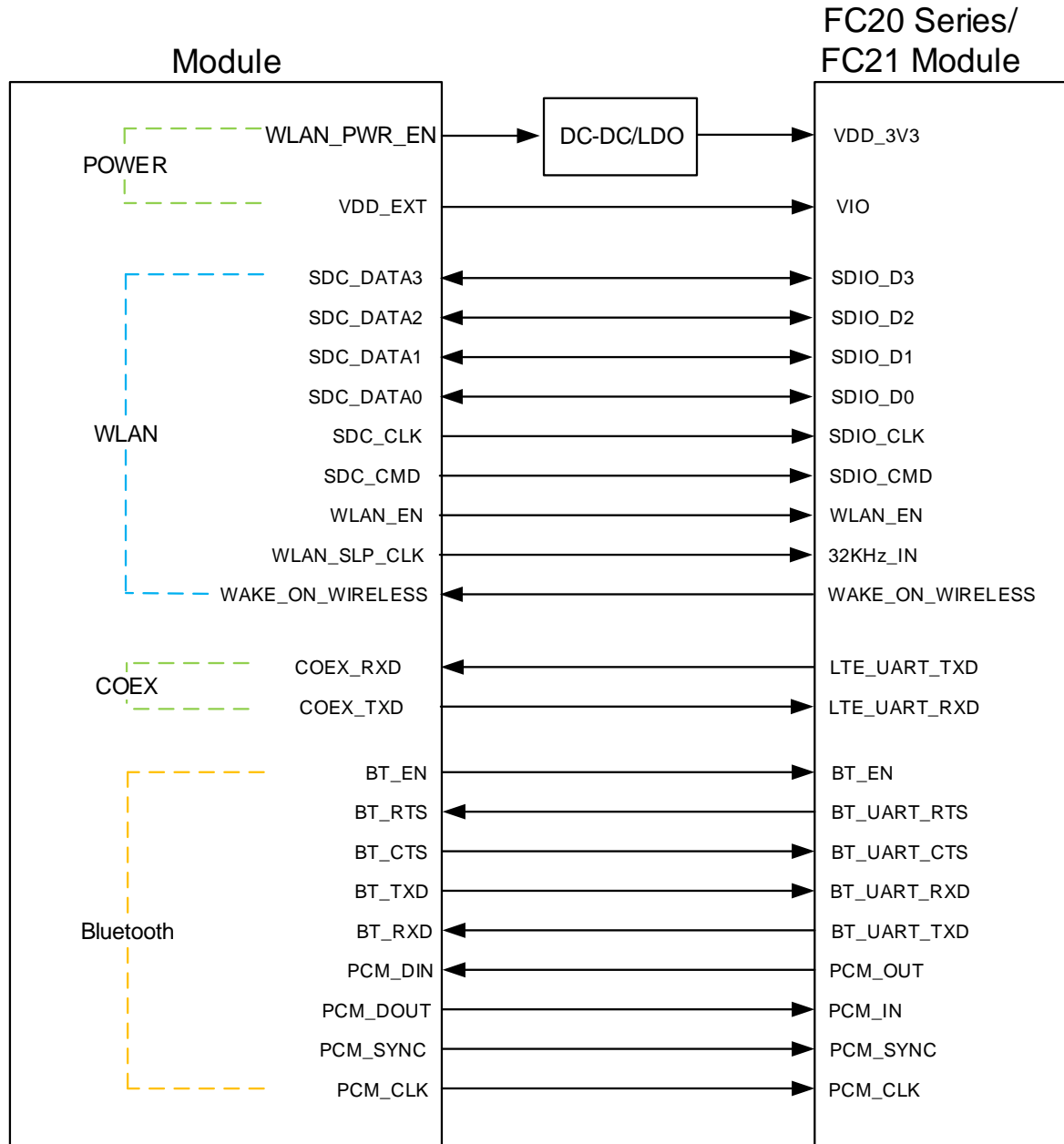

Figure 26: Reference Circuit of WLAN & Bluetooth Application Interfaces with FC20 Series/FC21

NOTE

1. FC20 series or FC21 module can only be used as a slave device.
2. When Bluetooth function* is enabled on the module, PCM_SYNC and PCM_CLK pins can only be used to output signals.
3. For more information about WLAN and Bluetooth application interfaces, see **document [5]**.

4.6.1 WLAN Application Interface

The module provides a SDIO 3.0 interface and control interface for WLAN design. SDIO interface supports SDR mode, and the maximum frequency is up to 50 MHz.

As SDIO signals are very high-speed, in order to ensure the SDIO interface design corresponds with the SDIO 3.0 specification, please comply with the following principles:

- It is important to route the SDIO signal traces with total grounding. The impedance of SDIO signal trace is $50\ \Omega \pm 10\%$.
- Keep SDIO signals far away from other sensitive circuits/signals such as RF circuits, analog signals, etc., as well as noisy signals such as clock signals, DC-DC signals, etc.
- It is recommended to keep matching length between SDC_CLK and SDC_DATA[0:3]/SDC_CMD less than 1 mm and total routing length less than 50 mm.
- Keep termination resistors within 15–24 Ω on clock traces near the module and keep the route distance from the module clock pins to termination resistors less than 5 mm.
- Make sure the adjacent trace spacing is 2 times of the trace width and bus capacitance is less than 15 pF.

4.6.2 Bluetooth Application Interface*

The module supports a dedicated UART interface and a PCM interface for Bluetooth application. Further information about Bluetooth interface will be added in the future version of this document.

4.7 ADC Interfaces

The module provides two Analog-to-Digital Converter (ADC) interfaces.

- **AT+QADC=0** can be used to read the voltage value on ADC0 pin.
- **AT+QADC=1** can be used to read the voltage value on ADC1 pin.

For more details about these AT commands, see **document [2]**. To improve the accuracy of ADC, the trace of ADC should be surrounded by ground.

Table 17: Pin Definition of ADC Interfaces

Pin Name	Pin No.	I/O	Description	Comment
ADC0	45	AI	General-purpose analog to digital converter	If unused, keep it open.
ADC1	44	AI	General-purpose analog to digital converter	

The following table describes the characteristic of ADC function.

Table 18: Characteristic of ADC

Parameter	Min.	Typ.	Max.	Unit
ADC0 Voltage Range	0.3	-	VBAT_BB	V
ADC1 Voltage Range	0.3	-	VBAT_BB	V
ADC Resolution	-	15	-	bits

NOTE

1. ADC input voltage must not exceed that of VBAT_BB.
2. It is prohibited to supply any voltage to ADC pins when VBAT power supply is removed.
3. It is recommended to use a resistor divider circuit for ADC application.

4.8 SGMII Interface

The module includes an integrated Ethernet MAC with four SGMII data signals, two management signals and two control signals. The key features of the SGMII interface are shown below:

- IEEE802.3 compliant
- Supports 10/100/1000 Mbps Ethernet work mode
- Supports maximum 150 Mbps (DL)/50 Mbps (UL) for 4G network
- Supports VLAN tagging
- Supports IEEE1588 and Precision Time Protocol (PTP)
- Can be used to connect to external Ethernet PHY like AR8033, or to an external switch
- Management interfaces support dual voltage 1.8/2.85 V

The following table shows the pin definition of SGMII interface.

Table 19: Pin Definition of SGMII Interface

Pin Name	Pin No.	I/O	Description	Comment
Control and Management Signals				
SGMII_RST_N	119	DO	Ethernet PHY reset	1.8/2.85 V power domain. If unused, keep it open.

SGMII_INT_N	120	DI	Ethernet PHY interrupt	1.8 V power domain. If unused, keep it open.
SGMII_MDIO	121	DIO	SGMII management data	1.8/2.85 V power domain. Require external pull-up to SGMII_MDIO_VDD, and the resistor should be 1.5 kΩ. If unused, keep it open.
SGMII_MDC	122	DO	SGMII management data clock	1.8/2.85 V power domain. If unused, keep it open.
SGMII_MDIO_VDD	128	PO	SGMII_MDIO pull up power supply	Configurable power source. 1.8/2.85 V power domain. If unused, keep it open.

SGMII Data Signals

SGMII_TX_M	123	AO	SGMII transmit (-)	
SGMII_TX_P	124	AO	SGMII transmit (+)	Connect with a 0.1 μF capacitor, which is close to the PHY side.
SGMII_RX_P	125	AI	SGMII receive (+)	If unused, keep it open.
SGMII_RX_M	126	AI	SGMII receive (-)	

The following figure shows the simplified block diagram for Ethernet application.

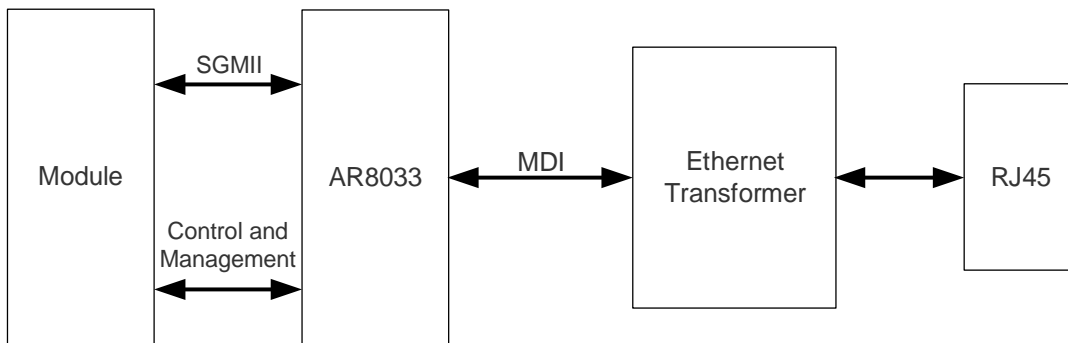

Figure 27: Simplified Block Diagram for Ethernet Application

The following figure shows a reference design of SGMII interface with PHY AR8033 application.

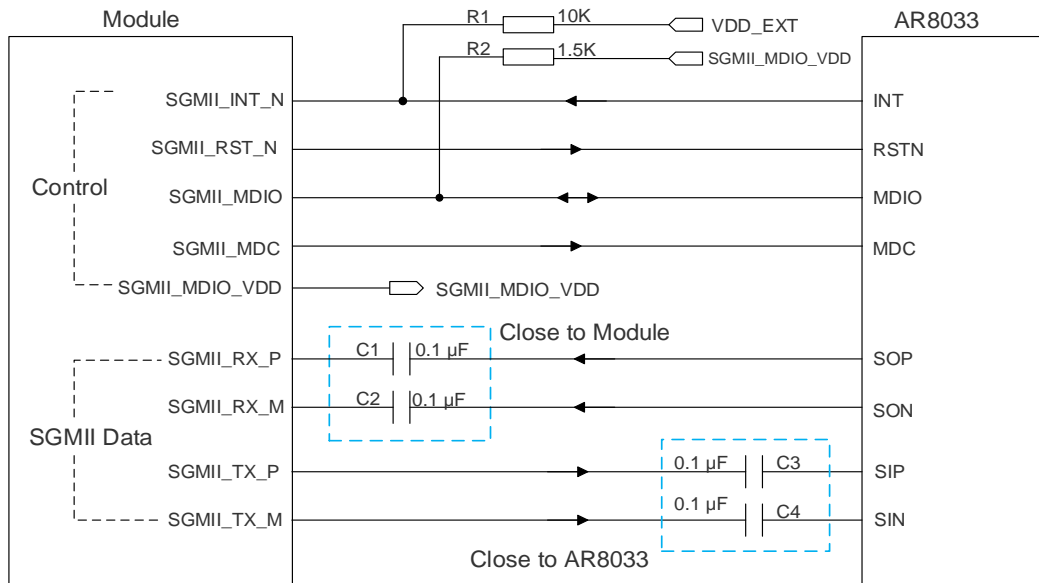

Figure 28: Reference Circuit of SGMII Interface with PHY AR8033 Application

In order to enhance the reliability and availability in your applications, please follow the criteria below in the Ethernet PHY circuit design:

- Keep SGMII data and control signals away from other sensitive circuits/signals such as RF circuits, analog signals, etc., as well as noisy signals such as clock signals, DC-DC signals, etc.
- Keep the maximum trace length less than 10 inches and keep skew on the differential pairs less than 20 mil.
- The differential impedance of SGMII data trace is $100 \Omega \pm 10\%$, and the reference ground of the area should be complete.
- Make sure the trace spacing between SGMII_TX_P/M and SGMII_RX_P/M is at least 3 times of the trace width, and the same to the adjacent signal traces.

4.9 Indication Signals

4.9.1 Network Status Indication

The network indication pins can be used to drive network status indication LEDs. The module provides two pins which are NET_MODE and NET_STATUS. The following tables describe the pin definition and logic level changes in different network status.

Table 20: Pin Definition of Network Connection Status/Activity Indication

Pin Name	Pin No.	I/O	Description	Comment
NET_MODE	5	DO	Indicate the module's network registration mode	1.8 V power domain. Cannot be pulled up before startup. If unused, keep it open.
NET_STATUS	6	DO	Indicate the module's network activity status	1.8 V power domain. If unused, keep it open.

Table 21: Working State of Network Connection Status/Activity Indication

Pin Name	Logic Level Changes	Network Status
NET_MODE	Always High	Registered on LTE network
	Always Low	Others
NET_STATUS	Flicker slowly (200 ms High/1800 ms Low)	Network searching
	Flicker slowly (1800 ms High/200 ms Low)	Idle
	Flicker quickly (125 ms High/125 ms Low)	Data transfer is ongoing
	Always High	Voice calling

A reference circuit is shown in the following figure.

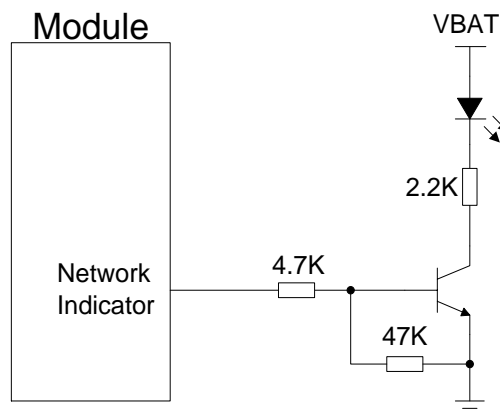

Figure 29: Reference Circuit of the Network Indication

4.9.2 STATUS

The STATUS pin is an open drain output for indicating the module’s operation status. It can be connected to a GPIO of DTE with a pull-up resistor, or as LED indication circuit as below. When the module is turned on normally, the STATUS will present the low state. Otherwise, the STATUS will present high-impedance state.

Table 22: Pin Definition of STATUS

Pin Name	Pin No.	I/O	Description	Comment
STATUS	61	OD	Indicate the module’s operation status	An external pull-up resistor is required. If unused, keep it open.

The following figure shows different circuit designs of STATUS, and you can choose either one according to your application demands.

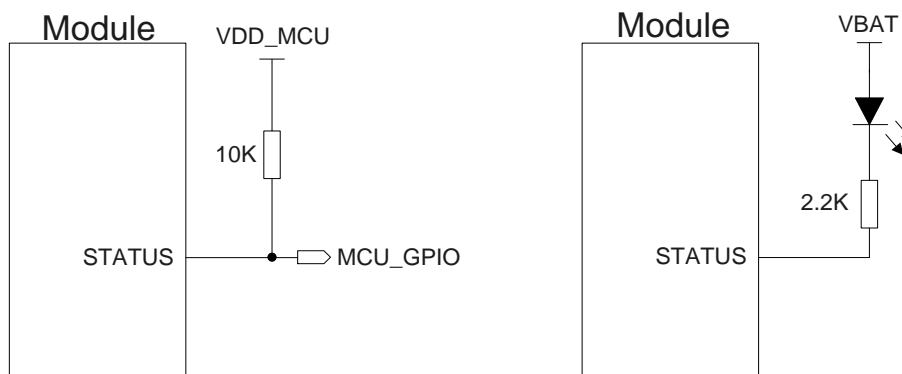

Figure 30: Reference Circuits of STATUS

NOTE

The status pin cannot be used as indication of module shutdown status when VBAT power supply is removed.

4.9.3 MAIN_RI

AT+QCFG="risignaltpe", "physical" can be used to configure MAIN_RI behaviors. No matter on which port a URC is presented, the URC will trigger the behaviors of MAIN_RI pin.

The default behaviors of the MAIN_RI are shown as below, and can be changed by **AT+QCFG="urc/ri/ring"**. See **document [3]** for details.

Table 23: Behaviors of MAIN_RI

State	Response
Idle	MAIN_RI keeps at high level
URC	MAIN_RI outputs 120 ms low pulse when a new URC returns

NOTE

A URC can be outputted from UART port, USB AT port and USB modem port through configuration via **AT+QURCCFG**. The default port is USB AT port. See **document [2]** for details.

4.10 USB_BOOT

The module provides a USB_BOOT pin. You can pull up USB_BOOT to 1.8 V before VDD_EXT is powered up, and the module will enter emergency download mode when it is powered on. In this mode, the module supports firmware upgrade over USB interface.

Table 24: Pin Definition of USB_BOOT Interface

Pin Name	Pin No.	I/O	Description	Comment
USB_BOOT	115	DI	Force the module into emergency download mode	1.8 V power domain. Cannot be pulled up before startup. It is recommended to reserve test point.

The following figures show the reference circuit of USB_BOOT interface and timing sequence of entering emergency download mode.

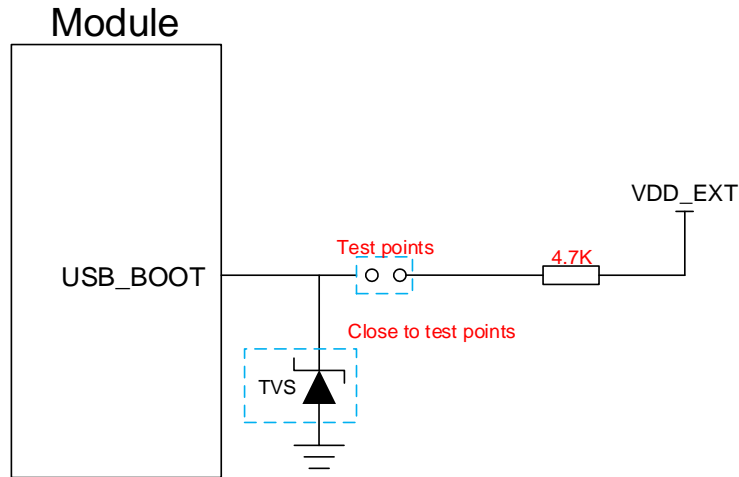

Figure 31: Reference Circuit of USB_BOOT Interface

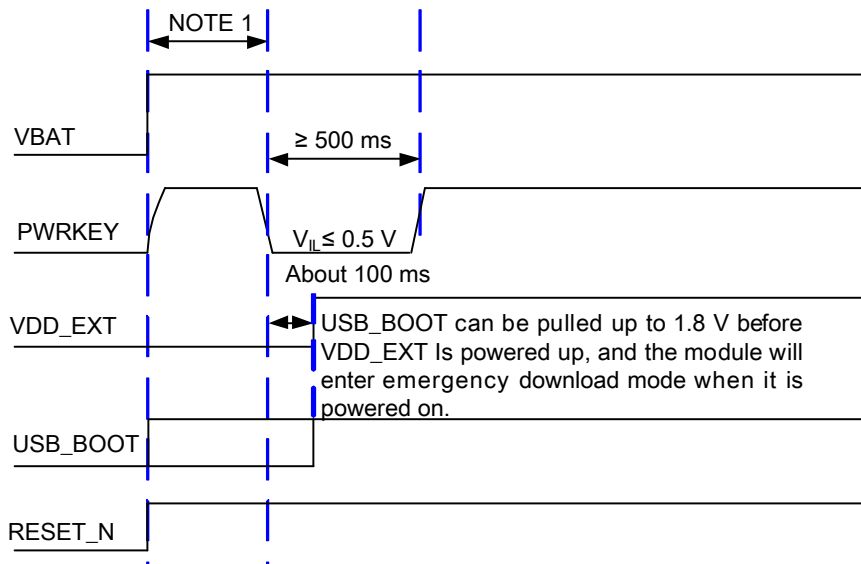

Figure 32: Timing Sequence for Entering Emergency Download Mode

NOTE

1. Make sure that VBAT is stable before pulling down PWRKEY pin. It is recommended that the time between powering up VBAT and pulling down PWRKEY pin is not less than 30 ms.
2. When using MCU to control module to enter the emergency download mode, please follow the above timing sequence. It is not recommended to pull up USB_BOOT to 1.8 V before powering up VBAT. Connect the test points as shown in **Figure 31** can manually force the module to enter download mode.

5 RF Specifications

5.1 Cellular Network

5.1.1 Antenna Interface & Frequency Bands

The pin definition of main antenna and Rx-diversity antenna interfaces is shown below.

Table 25: Pin Definition of Antenna Antennas

Pin Name	Pin No.	I/O	Description	Comment
ANT_MAIN	49	AIO	Main antenna interface	50 Ω impedance
ANT_DIV	35	AI	Diversity antenna interface	50 Ω impedance. If unused, keep it open.

Table 26: Frequency Bands

3GPP Bands	Transmit	Receive	Unit
GSM850	824–849	869–894	MHz
EGSM900	880–915	925–960	MHz
DCS1800	1710–1785	1805–1880	MHz
PCS1900	1850–1910	1930–1990	MHz
WCDMA B1	1920–1980	2110–2170	MHz
WCDMA B2	1850–1910	1930–1990	MHz
WCDMA B4	1710–1755	2110–2155	MHz
WCDMA B5	824–849	869–894	MHz
WCDMA B6	830–840	875–885	MHz

WCDMA B8	880–915	925–960	MHz
WCDMA B19	830–845	875–890	MHz
LTE-FDD B1	1920–1980	2110–2170	MHz
LTE-FDD B2	1850–1910	1930–1990	MHz
LTE-FDD B3	1710–1785	1805–1880	MHz
LTE-FDD B4	1710–1755	2110–2155	MHz
LTE-FDD B5	824–849	869–894	MHz
LTE-FDD B7	2500–2570	2620–2690	MHz
LTE-FDD B8	880–915	925–960	MHz
LTE-FDD B12	699–716	729–746	MHz
LTE-FDD B13	777–787	746–756	MHz
LTE-FDD B18	815–830	860–875	MHz
LTE-FDD B19	830–845	875–890	MHz
LTE-FDD B20	832–862	791–821	MHz
LTE-FDD B25	1850–1915	1930–1995	MHz
LTE-FDD B26	814–849	859–894	MHz
LTE-FDD B28	703–748	758–803	MHz
LTE-TDD B34	2010–2025	2010–2025	MHz
LTE-TDD B38	2570–2620	2570–2620	MHz
LTE-TDD B39	1880–1920	1880–1920	MHz
LTE-TDD B40	2300–2400	2300–2400	MHz
LTE-TDD B41	2496–2690	2496–2690	MHz
LTE-FDD B66	1710–1780	2110–2180	MHz

5.1.2 Tx Power

The following table shows the RF output power of the module.

Table 27: Tx Power

Frequency Bands	Max. RF Output Power	Min. RF Output Power
GSM850/EGSM900	33 dBm \pm 2 dB	5 dBm \pm 5 dB
DCS1800/PCS1900	30 dBm \pm 2 dB	0 dBm \pm 5 dB
GSM850/EGSM900 (8-PSK)	27 dBm \pm 3 dB	5 dBm \pm 5 dB
DCS1800/PCS1900 (8-PSK)	26 dBm \pm 3 dB	0 dBm \pm 5 dB
WCDMA bands	24 dBm +1/ -3 dB	< -49 dBm
LTE-FDD bands	23 dBm \pm 2 dB	< -39 dBm
LTE-TDD bands	23 dBm \pm 2 dB	< -39 dBm

NOTE

In GPRS 4 slots TX mode, the maximum output power is reduced by 3.0 dB. The design conforms to the GSM specification as described in **Chapter 13.16** of *3GPP TS 51.010-1*.

5.1.3 Rx Sensitivity

The following tables show the conducted RF receiving sensitivity of the module.

Table 28: EG25-GL Conducted RF Receiving Sensitivity

Frequency Bands	Receiving Sensitivity (Typ.)			3GPP (SIMO)
	Primary	Diversity	SIMO ⁶	
GSM850	-108 dBm	-	-	-102.4 dBm
EGSM900	-107 dBm	-	-	-102.4 dBm

⁶ SIMO is a smart antenna technology that uses a single antenna at the transmitter side and two antennas at the receiver side, which can improve Rx performance.

DCS1800	-107 dBm	-	-	-102.4 dBm
PCS1900	-107.5 dBm	-	-	-102.4 dBm
WCDMA B1	-108dBm	-109 dBm	-110 dBm	-106.7 dBm
WCDMA B2	-108 dBm	-108 dBm	-110 dBm	-104.7 dBm
WCDMA B4	-107 dBm	-109 dBm	-109 dBm	-106.7 dBm
WCDMA B5	-109.5 dBm	-109.5 dBm	-110.4 dBm	-104.7 dBm
WCDMA B6	-109 dBm	-110 dBm	-110.5 dBm	-106.7 dBm
WCDMA B8	-109.5 dBm	-110 dBm	-110 dBm	-103.7 dBm
WCDMA B19	-110 dBm	-109.5 dBm	-110.1 dBm	-106.7 dBm
LTE-FDD B1 (10 MHz)	-96.7 dBm	-96.3 dBm	-99.5 dBm	-96.3 dBm
LTE-FDD B2 (10 MHz)	-97.5 dBm	-97.5 dBm	-100 dBm	-94.3 dBm
LTE-FDD B3 (10 MHz)	-97 dBm	-97 dBm	-98 dBm	-93.3 dBm
LTE-FDD B4 (10 MHz)	-96.3 dBm	-96.3 dBm	-99.7 dBm	-96.3 dBm
LTE-FDD B5 (10 MHz)	-96.3 dBm	-96.4 dBm	-100 dBm	-94.3 dBm
LTE-FDD B7 (10 MHz)	-95.5 dBm	-94.8 dBm	-99.2 dBm	-94.3 dBm
LTE-FDD B8 (10 MHz)	-97 dBm	-97 dBm	-101 dBm	-93.3 dBm
LTE-FDD B12 (10 MHz)	-97.5 dBm	-98 dBm	-99.8 dBm	-93.3 dBm
LTE-FDD B13 (10 MHz)	-97.2 dBm	-97.3 dBm	-98 dBm	-93.3 dBm
LTE-FDD B18 (10 MHz)	-96.7 dBm	-96.4 dBm	-101 dBm	-96.3 dBm
LTE-FDD B19 (10 MHz)	-96.7 dBm	-96.5 dBm	-100.5 dBm	-96.3 dBm
LTE-FDD B20 (10 MHz)	-97.2 dBm	-97.4 dBm	--101 dBm	-93.3 dBm
LTE-FDD B25 (10 MHz)	-97.5 dBm	-97.4 dBm	-101 dBm	-92.8 dBm
LTE-FDD B26 (10 MHz)	-96.2 dBm	-97.3 dBm	-101 dBm	-93.8 dBm
LTE-FDD B28 (10 MHz)	-97 dBm	-98.0 dBm	-101 dBm	-94.8 dBm
LTE-TDD B34 (10 MHz)	-96.7 dBm	-96.8 dBm	-100.5 dBm	-96.3 dBm

LTE-TDD B38 (10 MHz)	-97 dBm	-97 dBm	-100 dBm	-96.3 dBm
LTE-TDD B39 (10 MHz)	-97.5 dBm	-97.5 dBm	-100 dBm	-96.3 dBm
LTE-TDD B40 (10 MHz)	-97.3 dBm	-97.5 dBm	-100.5dBm	-96.3 dBm
LTE-TDD B41 (10 MHz)	-96.3 dBm	-97 dBm	-99.5 dBm	-94.3 dBm
LTE-FDD B66 (10 MHz)	-96 dBm	-96 dBm	-99.5 dBm	-94.8 dBm

5.1.4 Reference Design

A reference design of ANT_MAIN and ANT_DIV antenna pads is shown as below. A π -type matching circuit should be reserved for better RF performance. The capacitors are not mounted by default.

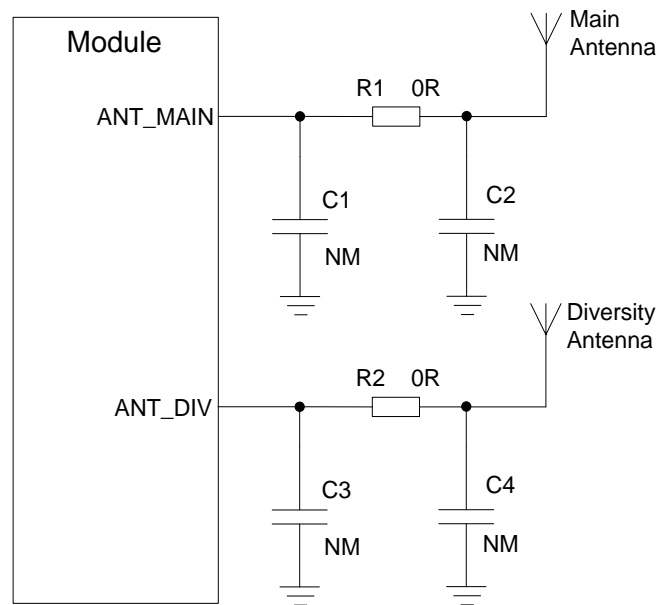

Figure 33: Reference Circuit of RF Antenna Interface

NOTE

1. Keep a proper distance between the main antenna and the Rx-diversity antenna to improve the receiving sensitivity.
2. For the operation of ANT_MAIN and ANT_DIV, see **AT+QCFG="divctl"** in **document [3]** for details.
3. Place the π -type matching components (R1, C1 and C2; R2, C3 and C4) as close to the antenna as possible.

5.2 GNSS

5.2.1 Antenna Interface & Frequency Bands

The module includes a fully integrated global navigation satellite system solution that supports GPS, GLONASS, BDS, Galileo and QZSS. The module supports standard NMEA 0183 protocol, and outputs NMEA sentences at 1 Hz data update rate via USB interface by default.

The GNSS engine of the module is switched off by default. It has to be switched on via AT command. For more details about GNSS engine technology and configurations, see **document [6]**.

Table 29: Pin Definition of GNSS Antenna Interface

Pin Name	Pin No.	I/O	Description	Comment
ANT_GNSS	47	AI	GNSS antenna interface	50 Ω impedance. If unused, keep it open.

Table 30: GNSS Frequency

Type	Frequency	Unit
GPS	1575.42 ±1.023 (L1)	MHz
GLONASS	1597.5–1605.8	MHz
Galileo	1575.42 ±2.046	MHz
BDS	1561.098 ±2.046	MHz
QZSS	1575.42	MHz

A reference design of GNSS antenna is shown as below.

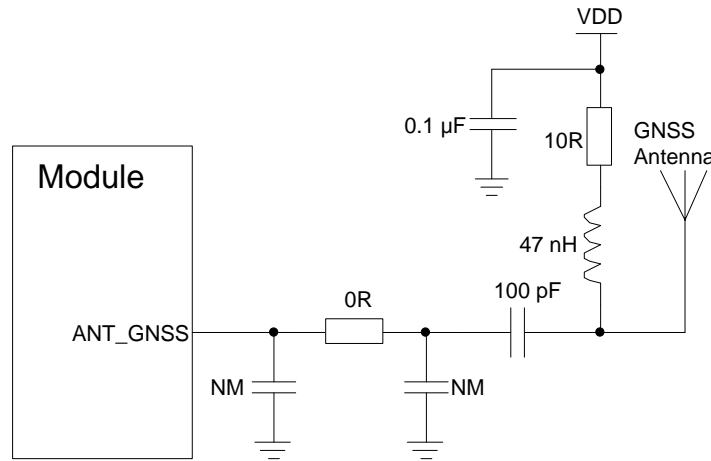

Figure 34: Reference Circuit of GNSS Antenna

NOTE

1. An external LDO can be selected to supply power according to the active antenna requirement.
2. If the module is designed with a passive antenna, then the VDD circuit is not needed.
3. It is recommended to use a passive GNSS antenna when LTE B13 is supported, as the use of active antenna may generate harmonics which will affect the GNSS performance.

5.2.2 GNSS Performance

The following table shows the GNSS performance of the module.

Table 31: GNSS Performance

Parameter	Description	Conditions	Typ.	Unit
Sensitivity	Acquisition	Autonomous	-146	dBm
	Reacquisition	Autonomous	-156	dBm
	Tracking	Autonomous	-157	dBm
TTFF	Cold start @ open sky	Autonomous	35	s
		XTRA enabled	15	s
	Warm start @ open sky	Autonomous	28	s
		XTRA enabled	3	s

	Hot start @ open sky	Autonomous	2	s
		XTRA enabled	1.6	s
Accuracy	CEP-50	Autonomous @ open sky	2.5	m

NOTE

1. Tracking sensitivity: the minimum GNSS signal power at which the module can maintain lock (keep positioning for at least 3 minutes continuously).
2. Reacquisition sensitivity: the minimum GNSS signal power required for the module to maintain lock within 3 minutes after loss of lock.
3. Acquisition sensitivity: the minimum GNSS signal power at which the module can fix position successfully within 3 minutes after executing cold start command.

5.2.3 Reference Design

The following layout guidelines should be taken into account in your design.

- Maximize the distance among GNSS antenna, main antenna and Rx-diversity antenna.
- Digital circuits such as (U)SIM card, USB interface, camera module and display connector should be kept away from the antennas.
- Use ground vias around the GNSS trace and sensitive analog signal traces to provide coplanar isolation and protection.
- Keep 50 Ω characteristic impedance for the ANT_GNSS trace.

5.3 RF Routing Guidelines

For user’s PCB, the characteristic impedance of all RF traces should be controlled to 50 Ω. The impedance of the RF traces is usually determined by the trace width (W), the materials’ dielectric constant, the height from the reference ground to the signal layer (H), and the spacing between RF traces and grounds (S). Microstrip or coplanar waveguide is typically used in RF layout to control characteristic impedance. The following are reference designs of microstrip or coplanar waveguide with different PCB structures.

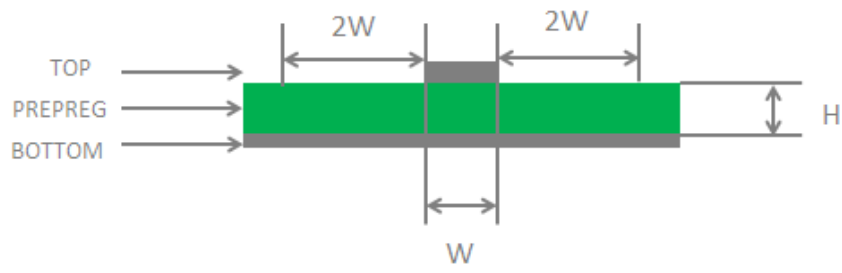

Figure 35: Microstrip Design on a 2-layer PCB

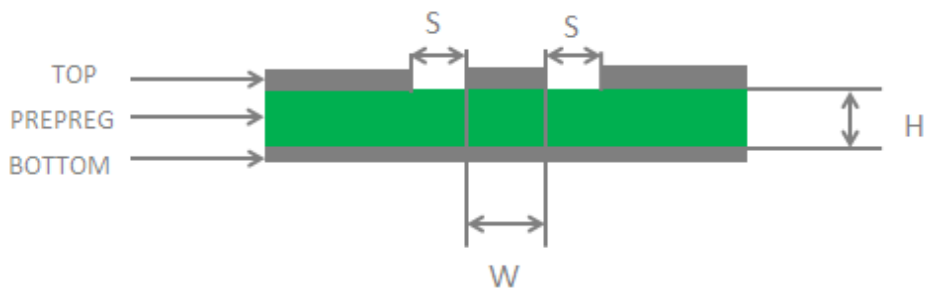

Figure 36: Coplanar Waveguide Design on a 2-layer PCB

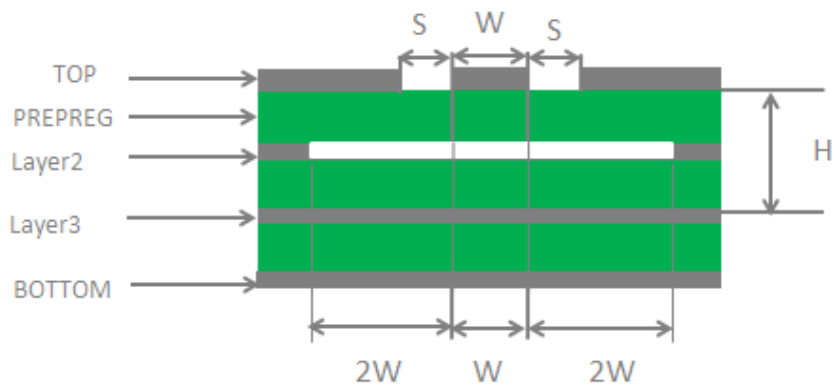

Figure 37: Coplanar Waveguide Design on a 4-layer PCB (Layer 3 as Reference Ground)

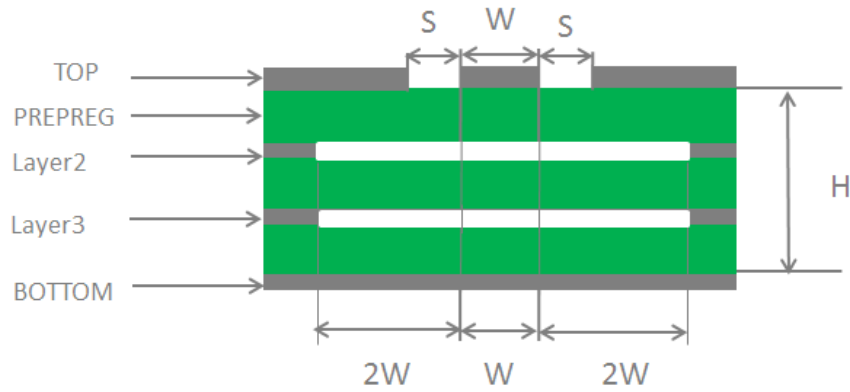

Figure 38: Coplanar Waveguide Design on a 4-layer PCB (Layer 4 as Reference Ground)

To ensure RF performance and reliability, follow the principles below in RF layout design:

- Use an impedance simulation tool to accurately control the characteristic impedance of RF traces to 50 Ω.
- The GND pins adjacent to RF pins should not be designed as thermal relief pads, and should be fully connected to ground.
- The distance between the RF pins and the RF connector should be as short as possible and all the right-angle traces should be changed to curved ones. The recommended trace angle is 135°.
- There should be clearance under the signal pin of the antenna connector or solder joint.
- The reference ground of RF traces should be complete. Meanwhile, adding some ground vias around RF traces and the reference ground could help to improve RF performance. The distance between the ground vias and RF traces should be not less than twice the width of RF signal traces (2 × W).
- Keep RF traces away from interference sources, and avoid intersection and paralleling between traces on adjacent layers.

For more details about RF layout, see **document [7]**.

5.4 Antenna Design Requirements

The following table shows the requirements on main antenna, Rx-diversity antenna and GNSS antenna.

Table 32: Antenna Requirements

Type	Requirements
GNSS	<ul style="list-style-type: none"> ● Frequency range: 1559–1609 MHz (L1) ● Polarization: RHCP or linear ● VSWR: ≤ 2 (Typ.)

GSM/WCDMA/LTE

- Passive antenna gain: > 0 dBi
 - Active antenna noise figure: < 1.5 dB
 - Active antenna gain: > 0 dBi
 - Active antenna embedded LNA gain: < 17 dB
-
- VSWR: ≤ 2
 - Efficiency: > 30%
 - Max. input power: 50 W
 - Input impedance: 50 Ω
 - Cable insertion loss:
 - < 1 dB: LB (<1 GHz)
 - < 1.5 dB: MB (1–2.3 GHz)
 - < 2 dB: HB (> 2.3 GHz)

NOTE

It is recommended to use a passive GNSS antenna when LTE B13 is supported, as the use of active antenna may generate harmonics which will affect the GNSS performance.

5.5 RF Connector Recommendation

If RF connector is used for antenna connection, it is recommended to use the U.FL-R-SMT connector provided by Hirose.

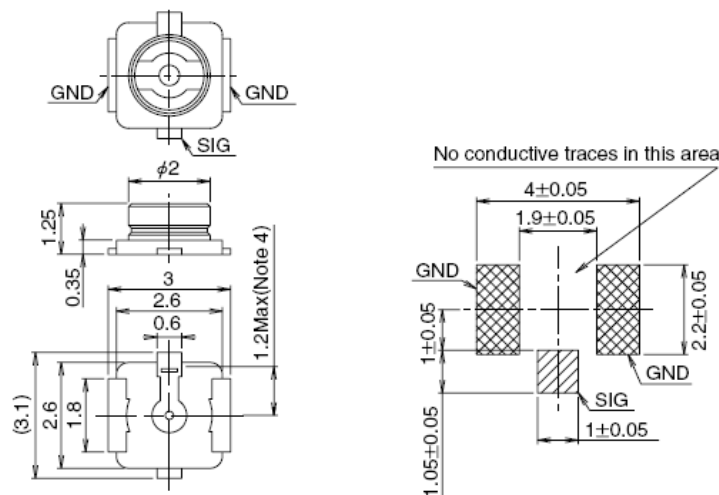

Figure 39: Dimensions of the Receptacle (Unit: mm)

U.FL-LP series mated plugs listed in the following figure can be used to match the U.FL-R-SMT connector.

Part No.	U.FL-LP-040	U.FL-LP-066	U.FL-LP(V)-040	U.FL-LP-062	U.FL-LP-088
Mated Height	2.5mm Max. (2.4mm Nom.)	2.5mm Max. (2.4mm Nom.)	2.0mm Max. (1.9mm Nom.)	2.4mm Max. (2.3mm Nom.)	2.4mm Max. (2.3mm Nom.)
Applicable cable	Dia. 0.81mm Coaxial cable	Dia. 1.13mm and Dia. 1.32mm Coaxial cable	Dia. 0.81mm Coaxial cable	Dia. 1mm Coaxial cable	Dia. 1.37mm Coaxial cable
Weight (mg)	53.7	59.1	34.8	45.5	71.7
RoHS	YES				

Figure 40: Specifications of Mated Plugs

The following figure describes the space factor of mated connectors.

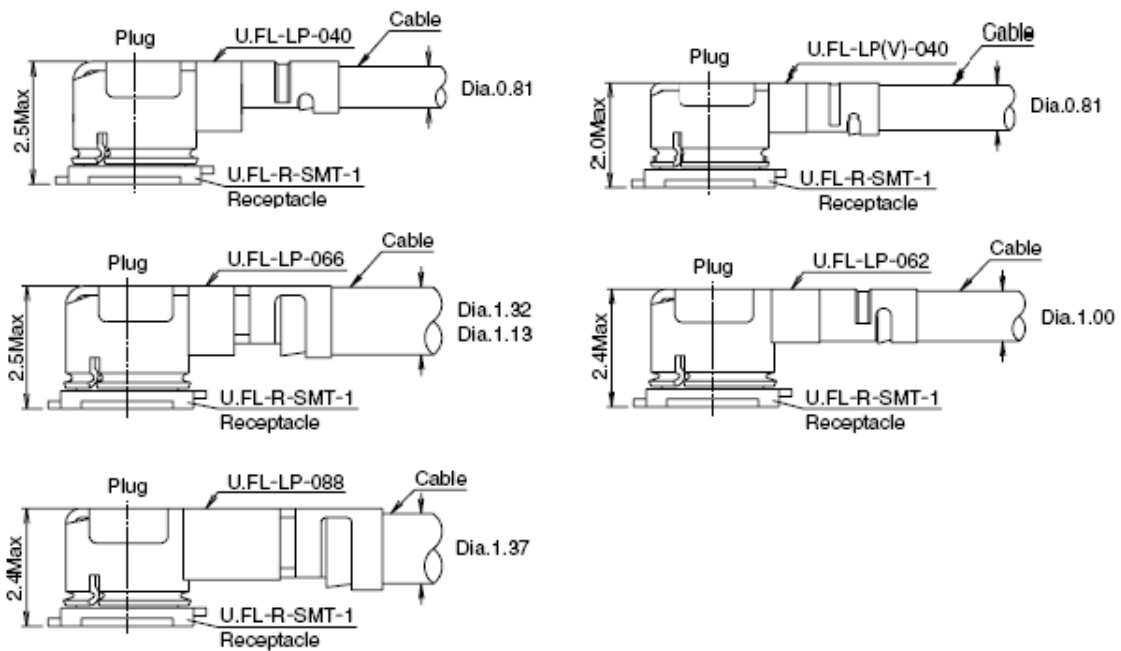

Figure 41: Space Factor of Mated Connectors (Unit: mm)

For more details, visit <http://www.hirose.com>

6 Electrical Characteristics and Reliability

6.1 Absolute Maximum Ratings

Absolute maximum ratings for power supply and voltage on digital and analog pins of the module are listed in the following table.

Table 33: Absolute Maximum Ratings

Parameter	Min.	Max.	Unit
VBAT_RF/VBAT_BB	-0.3	4.7	V
USB_VBUS	-0.3	5.5	V
Peak Current of VBAT_BB	-	0.8	A
Peak Current of VBAT_RF	-	1.8	A
Voltage at Digital Pins	-0.3	2.3	V
Voltage at ADC0	0	VBAT_BB	V
Voltage at ADC1	0	VBAT_BB	V

6.2 Power Supply Ratings

Table 34: Power Supply Ratings

Parameter	Description	Conditions	Min.	Typ.	Max.	Unit
VBAT	VBAT_BB and VBAT_RF	The actual input voltages must be kept between the minimum and maximum values.	3.3	3.8	4.3	V
	Voltage drop during burst transmission	Maximum power control level on EGSM900.	-	-	400	mV
I _{VBAT}	Peak supply current (during transmission slot)	Maximum power control level on EGSM900.	-	1.8	2.0	A
USB_VBUS	USB connection detection		3.0	5.0	5.25	V

6.3 Power Consumption

Table 35: EG25-GL Current Consumption

Description	Conditions	Typ.	Unit
Power-off	Power down	7	μA
Sleep State	AT+CFUN=0 (USB disconnected)	1.3	mA
	AT+CFUN=0 (USB suspended)	1.5	mA
	AT+CFUN=4 (USB disconnected)	1.3	mA
	AT+CFUN=4 (USB suspended)	1.5	mA
	GSM850 @ DRX = 2 (USB disconnected)	2.3	mA
	GSM850 @ DRX = 5 (USB disconnected)	1.8	mA
	GSM850 @ DRX = 5 (USB suspended)	2.0	mA
	GSM850 @ DRX = 9 (USB disconnected)	1.6	mA

	DCS1800 @ DRX = 2 (USB disconnected)	2.3	mA
	DCS1800 @ DRX = 5 (USB disconnected)	1.8	mA
	DCS1800 @ DRX = 5 (USB suspended)	2.0	mA
	DCS1800 @ DRX = 9 (USB disconnected)	1.6	mA
	WCDMA @ PF = 64 (USB disconnected)	2.2	mA
	WCDMA @ PF = 64 (USB suspended)	2.4	mA
	WCDMA @ PF = 128 (USB disconnected)	1.8	mA
	WCDMA @ PF = 256 (USB disconnected)	1.6	mA
	WCDMA @ PF = 512 (USB disconnected)	1.5	mA
	LTE-FDD @ PF = 32 (USB disconnected)	3.7	mA
	LTE-FDD @ PF = 64 (USB disconnected)	2.6	mA
	LTE-FDD @ PF = 64 (USB suspended)	2.8	mA
	LTE-FDD @ PF = 128 (USB disconnected)	2.0	mA
	LTE-FDD @ PF = 256 (USB disconnected)	1.7	mA
	LTE-TDD @ PF = 32 (USB disconnected)	4.0	mA
	LTE-TDD @ PF = 64 (USB disconnected)	2.6	mA
	LTE-TDD @ PF = 64 (USB suspended)	2.9	mA
	LTE-TDD @ PF = 128 (USB disconnected)	2.0	mA
	LTE-TDD @ PF = 256 (USB disconnected)	1.6	mA
Idle State	EGSM900 @ DRX = 5 (USB disconnected)	15.7	mA
	EGSM900 @ DRX = 5 (USB connected)	25.3	mA
	WCDMA @ PF = 64 (USB disconnected)	15.9	mA
	WCDMA @ PF = 64 (USB connected)	25.5	mA
	LTE-FDD @ PF = 64 (USB disconnected)	16.4	mA
	LTE-FDD @ PF = 64 (USB connected)	26.0	mA

	LTE-TDD @ PF = 64 (USB disconnected)	16.4	mA	
	LTE-TDD @ PF = 64 (USB connected)	26.2	mA	
	EGSM900 4DL/1UL @ 32 dBm	260	mA	
	EGSM900 3DL/2UL @ 31.09dBm	400	mA	
	EGSM900 2DL/3UL @ 29.2 dBm	490	mA	
	EGSM900 1DL/4UL @ 28.1 dBm	580	mA	
	GSM850 4DL/1UL @ 31.97 dBm	250	mA	
	GSM850 3DL/2UL @ 30.08 dBm	370	mA	
	GSM850 2DL/3UL @ 29.08 dBm	470	mA	
GPRS Data Transfer (GNSS OFF)	GSM850 1DL/4UL @ 27.93 dBm	580	mA	
	DCS1800 4DL/1UL @ 28.69 dBm	180	mA	
	DCS1800 3DL/2UL @ 28.25 dBm	280	mA	
	DCS1800 2DL/3UL @ 26.28 dBm	350	mA	
	DCS1800 1DL/4UL @ 25.51 dBm	460	mA	
	PCS1900 4DL/1UL @ 29.21 dBm	170	mA	
	PCS1900 3DL/2UL @ 28.30 dBm	270	mA	
	PCS1900 2DL/3UL @ 26.86 dBm	350	mA	
	PCS1900 1DL/4UL @ 25.57 dBm	440	mA	
		EGSM900 4DL/1UL @ 26.11 dBm	190	mA
		EGSM900 3DL/2UL @ 24.93 dBm	320	mA
		EGSM900 2DL/3UL @ 23.24 dBm	450	mA
EDGE Data Transfer (GNSS OFF)	EGSM900 1DL/4UL @ 22.07 dBm	560	mA	
	GSM850 4DL/1UL @ 25.92 dBm	190	mA	
	GSM850 3DL/2UL @ 24.79 dBm	320	mA	
	GSM850 2DL/3UL @ 22.89 dBm	450	mA	

	GSM850 1DL/4UL @ 21.71 dBm	560	mA
	DCS1800 4DL/1UL @ 25.19 dBm	160	mA
	DCS1800 3DL/2UL @ 24.61 dBm	270	mA
	DCS1800 2DL/3UL @ 23.48 dBm	380	mA
	DCS1800 1DL/4UL @ 22.25 dBm	480	mA
	PCS1900 4DL/1UL @ 25.24 dBm	160	mA
	PCS1900 3DL/2UL @ 24.76 dBm	270	mA
	PCS1900 2DL/3UL @ 23.6 dBm	380	mA
	PCS1900 1DL/4UL @ 22.27 dBm	480	mA
	WCDMA B1 HSDPA @ 22.6 dBm	600	mA
	WCDMA B1 HSUPA @ 22.4 dBm	580	mA
	WCDMA B2 HSDPA @ 22.73 dBm	700	mA
	WCDMA B2 HSUPA @ 22.89 dBm	690	mA
	WCDMA B4 HSDPA @ 22.72 dBm	630	mA
	WCDMA B4 HSUPA @ 22.24 dBm	610	mA
WCDMA Data Transfer (GNSS OFF)	WCDMA B5 HSDPA @ 22.48 dBm	750	mA
	WCDMA B5 HSUPA @ 22 dBm	740	mA
	WCDMA B6 HSDPA @ 22.38 dBm	760	mA
	WCDMA B6 HSUPA @ 21.95 dBm	720	mA
	WCDMA B8 HSDPA @ 22.45 dBm	745	mA
	WCDMA B8 HSUPA @ 22 dBm	730	mA
	WCDMA B19 HSDPA @ 22.4 dBm	740	mA
	WCDMA B19 HSUPA @ 21.93 dBm	710	mA
LTE Data Transfer (GNSS OFF)	LTE-FDD B1 @ 23.4 dBm	770	mA
	LTE-FDD B2 @ 23.57 dBm	850	mA

	LTE-FDD B3 @ 23.52 dBm	760	mA
	LTE-FDD B4 @ 23.42 dBm	785	mA
	LTE-FDD B5 @ 23.27 dBm	840	mA
	LTE-FDD B7 @ 23.3 dBm	1050	mA
	LTE-FDD B8 @ 23.14 dBm	950	mA
	LTE-FDD B12 @ 23.33 dBm	830	mA
	LTE-FDD B13 @ 23.2 dBm	760	mA
	LTE-FDD B18 @ 23.2 dBm	930	mA
	LTE-FDD B19 @ 23.02 dBm	910	mA
	LTE-FDD B20 @ 23.16 dBm	910	mA
	LTE-FDD B25 @ 23.26 dBm	820	mA
	LTE-FDD B26 @ 23.06 dBm	920	mA
	LTE-FDD B28 @ 23.55 dBm	860	mA
	LTE-TDD B34 @ 22.75 dBm	380	mA
	LTE-TDD B38 @ 22.86 dBm	450	mA
	LTE-TDD B39 @ 22.82 dBm	360	mA
	LTE-TDD B40 @ 22.94 dBm	400	mA
	LTE-TDD B41 @ 22.90 dBm	490	mA
	LTE-FDD B66 @ 23.40 dBm	780	mA
GSM Voice Call	EGSM900 PCL = 5 @ 32.22 dBm	270	mA
	EGSM900 PCL = 12 @ 19.71 dBm	140	mA
	EGSM900 PCL = 19 @ 3.09 dBm	90	mA
	GSM850 PCL = 5 @ 32.05 dBm	250	mA
	GSM850 PCL = 12 @ 19.33 dBm	150	mA
	GSM850 PCL = 19 @ 2.92 dBm	90	mA

	DCS1800 PCL = 0 @ 28.91 dBm	180	mA
	DCS1800 PCL = 7 @ 15.83 dBm	140	mA
	DCS1800 PCL = 15 @ -2.91 dBm	80	mA
	PCS1900 PCL = 0 @ 29.31 dBm	170-	mA
	PCS1900 PCL = 7 @ 15.81 dBm	140	mA
	PCS1900 PCL = 15 @ -2.75 dBm	78	mA
WCDMA Voice Call	WCDMA B1 @ 23.65 dBm	670	mA
	WCDMA B2 @ 23.96 dBm	750	mA
	WCDMA B4 @ 23.77 dBm	700	mA
	WCDMA B5 @ 23.51 dBm	830	mA
	WCDMA B6 @ 23.5 dBm	800	mA
	WCDMA B8 @ 23.6 dBm	690	mA
	WCDMA B19 @ 23.39 dBm	770	mA

6.4 ESD Protection

Static electricity occurs naturally and it may damage the module. Therefore, applying proper ESD countermeasures and handling methods is imperative. For example, wear anti-static gloves during the development, production, assembly and testing of the module; add ESD protection components to the ESD sensitive interfaces and points in the product design.

Table 36: Electrostatic Discharge Characteristics (25 °C, 45 % Relative Humidity)

Tested Interfaces	Contact Discharge	Air Discharge	Unit
VBAT, GND	±10	±16	kV
All Antenna Interfaces	±10	±16	kV
Other Interfaces	±0.5	±1	kV

6.5 Operating and Storage Temperatures

The operating and storage temperatures are listed in the following table.

Table 37: Operating and Storage Temperatures

Parameter	Min.	Typ.	Max.	Unit
Operating Temperature Range ⁷	-35	+25	+75	°C
Extended Temperature Range ⁸	-40	-	+85	°C
Storage Temperature Range	-40	-	+90	°C

⁷ Within operation temperature range, the module is 3GPP compliant.

⁸ Within the extended temperature range, the module remains the ability to establish and maintain functions such as voice, SMS, data transmission, etc., without any unrecoverable malfunction. Radio spectrum and radio network are not influenced, while one or more specifications, such as P_{out} , may exceed the specified tolerances of 3GPP. When the temperature returns to the operating temperature range, the module meets 3GPP specifications again.

7 Mechanical Information

This chapter describes the mechanical dimensions of the module. All dimensions are measured in mm, and the dimensional tolerances are ± 0.2 mm unless otherwise specified.

7.1 Mechanical Dimensions

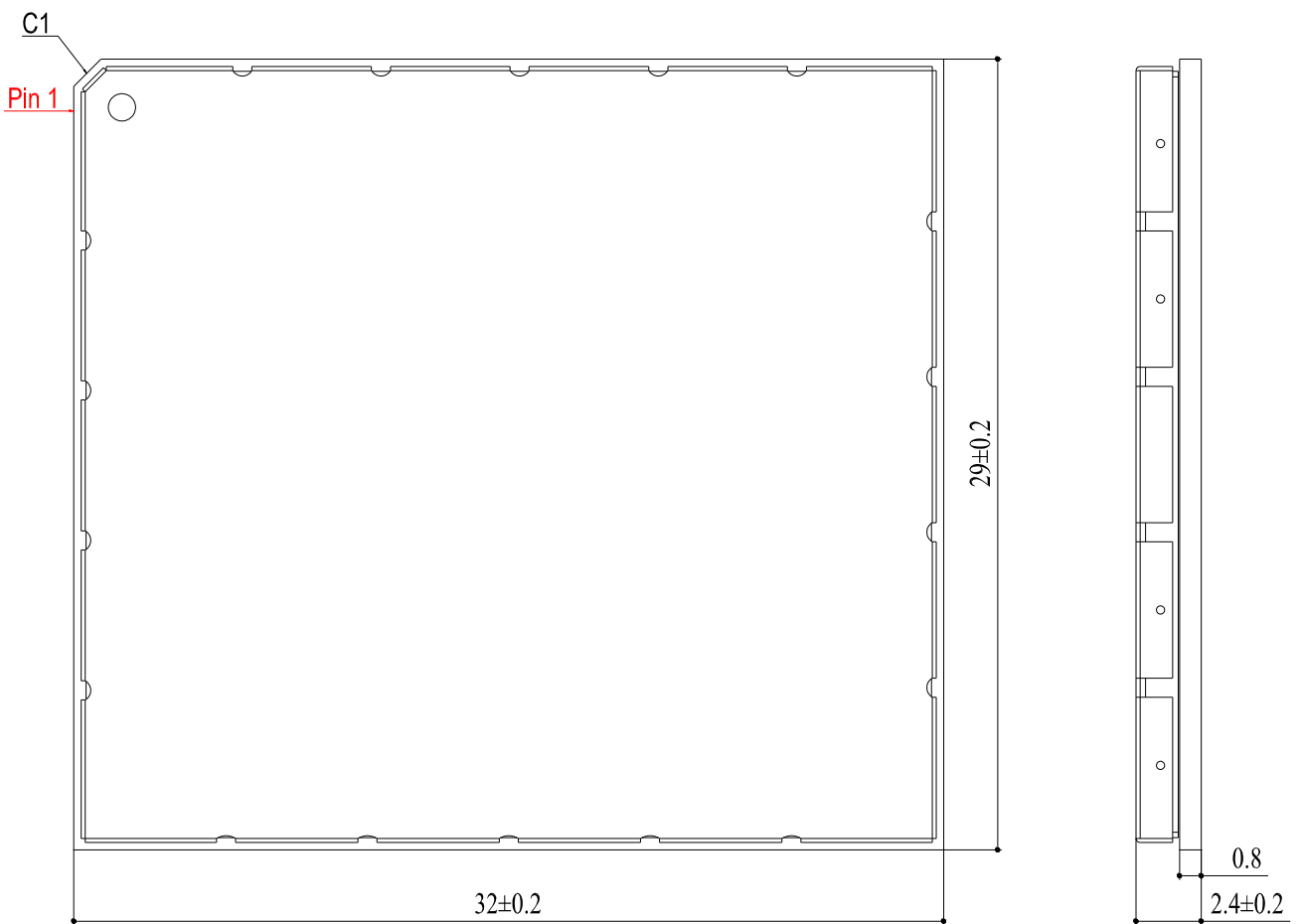

Figure 42: Module Top and Side Dimensions

7.4 Top and Bottom Views

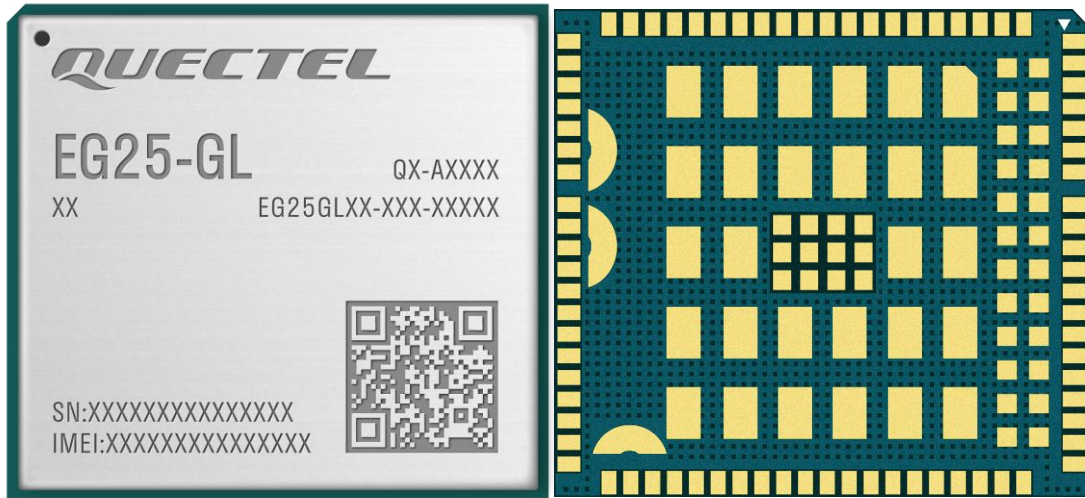

Figure 46: Top and Bottom Views of the Module

NOTE

Images above are for illustration purpose only and may differ from the actual module. For authentic appearance and label, please refer to the module received from Quectel.

8 Storage, Manufacturing and Packaging

8.1 Storage Conditions

The module is provided with vacuum-sealed packaging. MSL of the module is rated as 3. The storage requirements are shown below.

1. Recommended Storage Condition: the temperature should be 23 ± 5 °C and the relative humidity should be 35–60 %.
2. Shelf life (in a vacuum-sealed packaging): 12 months in Recommended Storage Condition.
3. Floor life: 168 hours ⁹ in a factory where the temperature is 23 ± 5 °C and relative humidity is below 60 %. After the vacuum-sealed packaging is removed, the module must be processed in reflow soldering or other high-temperature operations within 168 hours. Otherwise, the module should be stored in an environment where the relative humidity is less than 10 % (e.g., a dry cabinet).
4. The module should be pre-baked to avoid blistering, cracks and inner-layer separation in PCB under the following circumstances:
 - The module is not stored in Recommended Storage Condition;
 - Violation of the third requirement mentioned above;
 - Vacuum-sealed packaging is broken, or the packaging has been removed for over 24 hours;
 - Before module repairing.
5. If needed, the pre-baking should follow the requirements below:
 - The module should be baked for 8 hours at 120 ± 5 °C;
 - The module must be soldered to PCB within 24 hours after the baking, otherwise it should be put in a dry environment such as in a dry cabinet.

⁹ This floor life is only applicable when the environment conforms to *IPC/JEDEC J-STD-033*. It is recommended to start the solder reflow process within 24 hours after the package is removed if the temperature and moisture do not conform to, or are not sure to conform to *IPC/JEDEC J-STD-033*. And do not remove the packages of tremendous modules if they are not ready for soldering.

NOTE

1. To avoid blistering, layer separation and other soldering issues, extended exposure of the module to the air is forbidden.
2. Take out the module from the package and put it on high-temperature-resistant fixtures before baking. If shorter baking time is desired, see *IPC/JEDEC J-STD-033* for the baking procedure.
3. Pay attention to ESD protection, such as wearing anti-static gloves, when touching the modules.

8.2 Manufacturing and Soldering

Push the squeegee to apply the solder paste on the surface of stencil, thus making the paste fill the stencil openings and then penetrate to the PCB. Apply proper force on the squeegee to produce a clean stencil surface on a single pass. To guarantee module soldering quality, the thickness of stencil for the module is recommended to be 0.13–0.15 mm. For more details, see **document [8]**.

The peak reflow temperature should be 235–246 °C, with 246 °C as the absolute maximum reflow temperature. To avoid damage to the module caused by repeated heating, it is strongly recommended that the module should be mounted only after reflow soldering for the other side of PCB has been completed. The recommended reflow soldering thermal profile (lead-free reflow soldering) and related parameters are shown below.

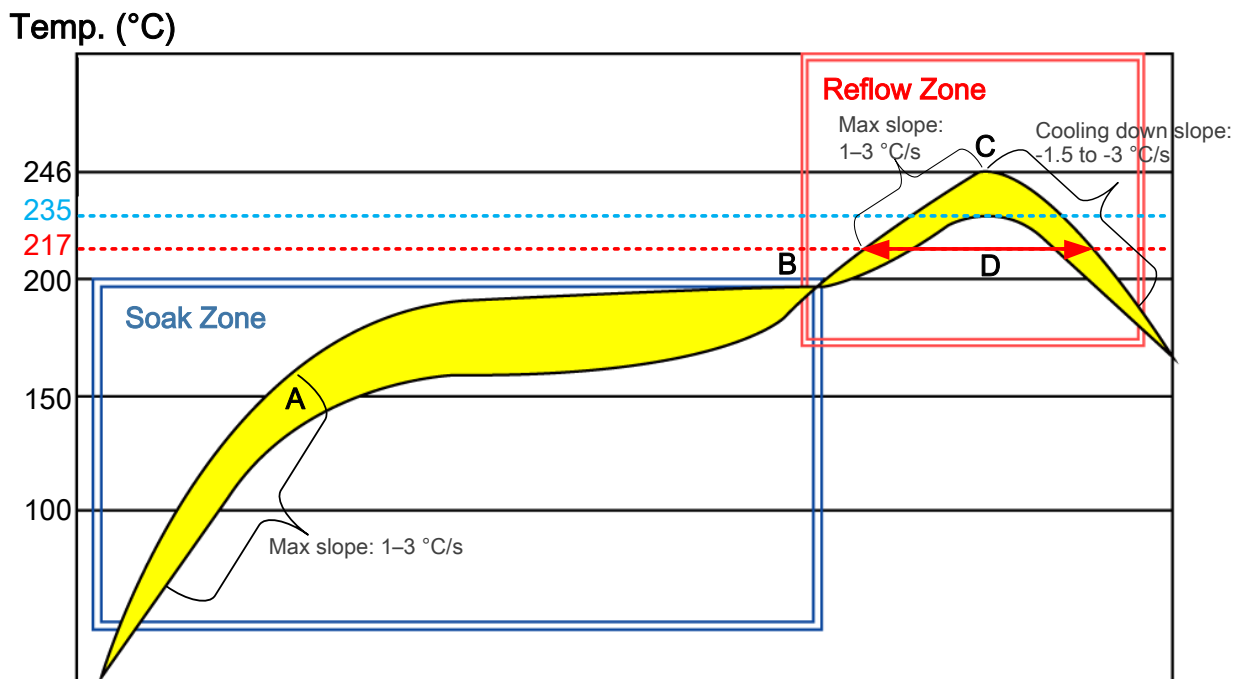

Figure 47: Recommended Reflow Soldering Thermal Profile

Table 38: Recommended Thermal Profile Parameters

Factor	Recommendation
Soak Zone	
Max slope	1–3 °C/s
Soak time (between A and B: 150 °C and 200 °C)	70–120 s
Reflow Zone	
Max slope	1–3 °C/s
Reflow time (D: over 217 °C)	40–70 s
Max temperature	235 °C to 246 °C
Cooling down slope	-1.5 to -3 °C/s
Reflow Cycle	
Max reflow cycle	1

NOTE

1. If a conformal coating is necessary for the module, do NOT use any coating material that may chemically react with the PCB or shielding cover, and prevent the coating material from flowing into the module.
2. Avoid using ultrasonic technology for module cleaning since it can damage crystals inside the module.
3. Due to the complexity of the SMT process, please contact Quectel Technical Support in advance for any situation that you are not sure about, or any process (e.g. selective soldering, ultrasonic soldering) that is not mentioned in **document [8]**.

8.3 Packaging Specifications

This chapter describes only the key parameters and process of packaging. All figures below are for reference only. The appearance and structure of the packaging materials are subject to the actual delivery.

The module adopts carrier tape packaging and details are as follow:

8.3.1 Carrier Tape

Dimension details are as follow:

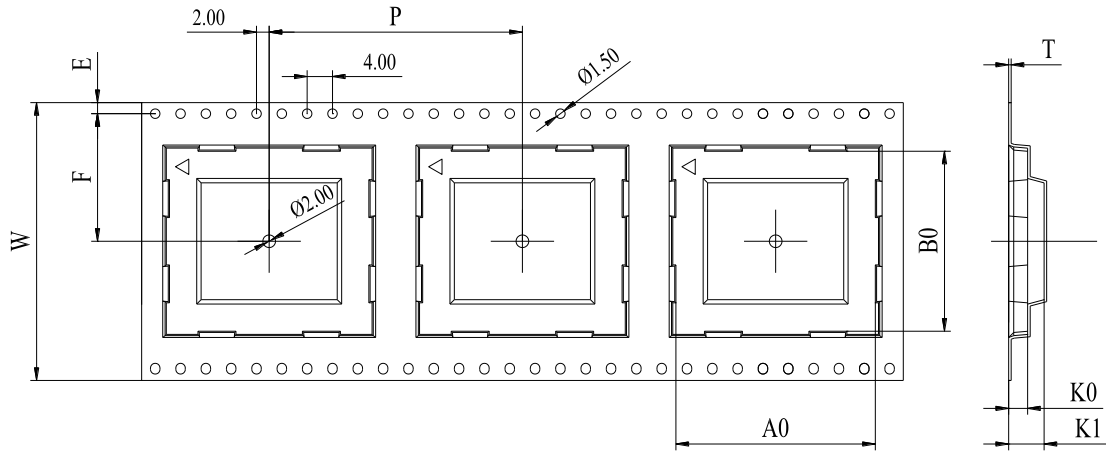

Figure 48: Carrier Tape Dimension Drawing

Table 39: Carrier Tape Dimension Table (Unit: mm)

W	P	T	A0	B0	K0	K1	F	E
44	44	0.35	32.5	29.5	3.0	3.8	20.2	1.75

8.3.2 Plastic Reel

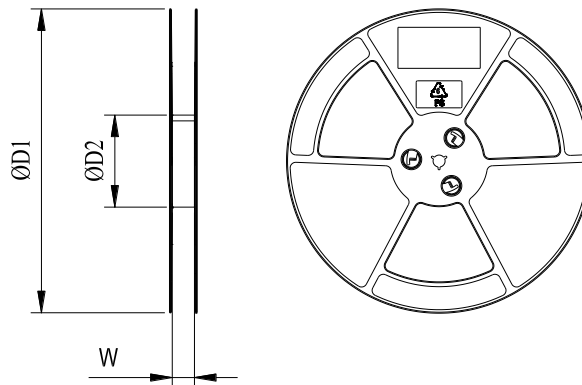
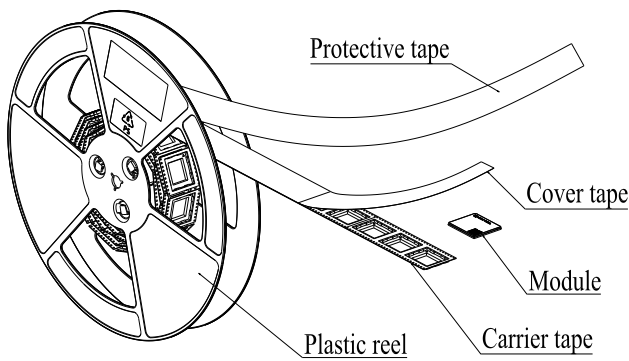

Figure 49: Plastic Reel Dimension Drawing

Table 40: Plastic Reel Dimension Table (Unit: mm)

$\phi D1$	$\phi D2$	W
330	100	44.5

8.3.3 Packaging Process



Place the module into the carrier tape and use the cover tape to cover it; then wind the heat-sealed carrier tape to the plastic reel and use the protective tape for protection. 1 plastic reel can load 250 modules.

Place the packaged plastic reel, 1 humidity indicator card and 1 desiccant bag into a vacuum bag, vacuumize it.

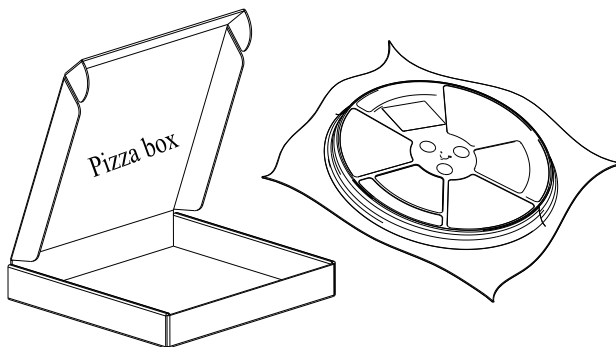
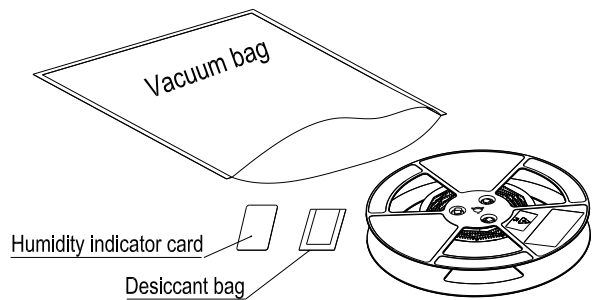

Place the vacuum-packed plastic reel into the pizza box.

Put 4 packaged pizza boxes into 1 carton box and seal it. 1 carton box can pack 1000 modules.

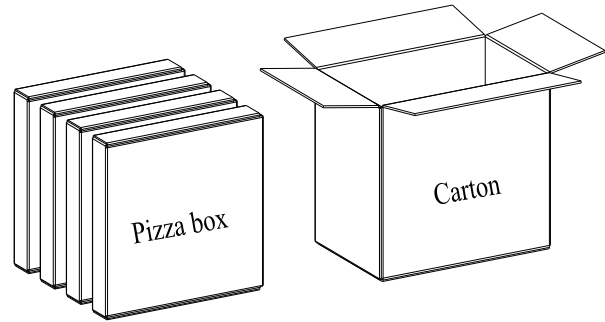

Figure 50: Packaging Process

9. Appendix References

Table 41: Related Documents

Document Name
[1] Quectel_UMTS<E_EVB_User_Guide
[2] Quectel_EC2x&EG2x-G(L)&EG9x&EM05_Series_AT_Commands_Manual
[3] Quectel_EC2x&EG2x-G(L)&EG9x&EM05_Series_QCFG_AT_Commands_Manual
[4] Quectel_EC2x&EG9x&EG2x-G(L)_Series_Power_Management_Application_Note
[5] Quectel_EG25-GL_Reference_Design
[6] Quectel_EC2x&EG2x-G(L)&EG9x&EM05_Series_GNSS_Application_Note
[7] Quectel_RF_Layout_Application_Note
[8] Quectel_Module_Secondary_SMT_Application_Note

Table 42: Terms and Abbreviations

Abbreviation	Description
AMR	Adaptive Multi-rate
AMR-WB	Adaptive Multi-Rate Wideband
bps	Bits Per Second
CHAP	Challenge Handshake Authentication Protocol
CS	Coding Scheme
CTS	Clear To Send
DC-HSPA+	Dual-carrier High Speed Packet Access
DCS	Digital Cellular System

DDR	Double Data Rate
DFOTA	Delta Firmware Upgrade Over The Air
DL	Downlink
DTR	Data Terminal Ready
DTX	Discontinuous Transmission
EDGE	Enhanced Data Rates for GSM Evolution
EFR	Enhanced Full Rate
EGSM	Enhanced GSM
ESD	Electrostatic Discharge
EVB	Evaluation Board
FDD	Frequency Division Duplex
FR	Full Rate
FTP	File Transfer Protocol
FTPS	FTP over SSL
GLONASS	Global Navigation Satellite System (Russia)
GMSK	Gaussian Minimum Shift Keying
GNSS	Global Navigation Satellite System
GPS	Global Positioning System
GSM	Global System for Mobile Communications
HR	Half Rate
HSPA	High Speed Packet Access
HSDPA	High Speed Downlink Packet Access
HSUPA	High Speed Uplink Packet Access
HTTP	Hypertext Transfer Protocol
HTTPS	Hypertext Transfer Protocol Secure

I/O	Input/Output
LED	Light Emitting Diode
LGA	Land Grid Array
LNA	Low Noise Amplifier
LTE	Long Term Evolution
M2M	Machine to Machine
MCS	Modulation and Coding Scheme
ME	Mobile Equipment
MIMO	Multiple Input Multiple Output
MMS	Multimedia Messaging Service
MO	Mobile Originated
MQTT	Message Queuing Telemetry Transport
MS	Mobile Station (GSM engine)
MSL	Moisture Sensitivity Level
MT	Mobile Terminated
NITZ	Network Identity and Time Zone
NMEA	NMEA (National Marine Electronics Association) 0183 Interface Standard
NTP	Network Time Protocol
PAP	Password Authentication Protocol
PCB	Printed Circuit Board
PCM	Pulse Code Modulation
PDA	Personal Digital Assistant
PDU	Protocol Data Unit
PING	Packet Internet Groper
POS	Point of Sale

PPP	Point-to-Point Protocol
QAM	Quadrature Amplitude Modulation
QPSK	Quadrature Phase Shift Keying
QZSS	Quasi-Zenith Satellite System
RF	Radio Frequency
RHCP	Right Hand Circularly Polarized
RTS	Ready To Send
Rx	Receive
SDR	Software-Defined Radio
SGMII	Serial Gigabit Media Independent Interface
SIMO	Single Input Multiple Output
SMD	Surface Mount Device
SMS	Short Message Service
SMTP	Simple Mail Transfer Protocol
SMTPS	Simple Mail Transfer Protocol Secure
SSL	Secure Sockets Layer
TCP	Transmission Control Protocol
TDD	Time Division Duplexing
TVS	Transient Voltage Suppressor
TX	Transmitting Direction
UDP	User Datagram Protocol
UL	Uplink
UMTS	Universal Mobile Telecommunications System
URC	Unsolicited Result Code
(U)SIM	(Universal) Subscriber Identity Module

VLAN	Virtual Local Area Network
Vmax	Maximum Voltage
Vnom	Normal Voltage
Vmin	Minimum Voltage
V _{IHmax}	Maximum High-level Input Voltage
V _{IHmin}	Minimum High-level Input Voltage
V _{ILmax}	Maximum Low-level Input Voltage
V _{ILmin}	Minimum Low-level Input Voltage
V _{OHmax}	Maximum High-level Output Voltage
V _{OHmin}	Minimum High-level Output Voltage
V _{OLmax}	Maximum Low-level Output Voltage
V _{OLmin}	Minimum Low-level Output Voltage
VSWR	Voltage Standing Wave Ratio
WCDMA	Wideband Code Division Multiple Access
WLAN	Wireless Local Area Network

OEM/Integrators Installation Manual

Important Notice to OEM integrators 1. This module is limited to OEM installation ONLY. 2. This module is limited to installation in mobile or fixed applications, according to Part 2.1091(b). 3. The separate approval is required for all other operating configurations, including portable configurations with respect to Part 2.1093 and different antenna configurations 4. For FCC Part 15.31 (h) and (k): The host manufacturer is responsible for additional testing to verify compliance as a composite system. When testing the host device for compliance with Part 15 Subpart B, the host manufacturer is required to show compliance with Part 15 Subpart B while the transmitter module(s) are installed and operating. The modules should be transmitting and the evaluation should confirm that the module's intentional emissions are compliant (i.e. fundamental and out of band emissions). The host manufacturer must verify that there are no additional unintentional emissions other than what is permitted in Part 15 Subpart B or emissions are complaint with the transmitter(s) rule(s). The Grantee will provide guidance to the host manufacturer for Part 15 B requirements if needed.

Important Note

notice that any deviation(s) from the defined parameters of the antenna trace, as described by the instructions, require that the host product manufacturer must notify to Quectel that they wish to change the antenna trace design. In this case, a Class II permissive change application is required to be filed by the USI, or the host manufacturer can take responsibility through the change in FCC ID (new application) procedure followed by a Class II permissive change application

End Product Labeling

When the module is installed in the host device, the FCC/IC ID label must be visible through a window on the final device or it must be visible when an access panel, door or cover is easily re-moved. If not, a second label must be placed on the outside of the final device that contains the following text: "Contains FCC ID: XMR202212EG25GL" "Contains IC: 10224A-2022EG25GL". The FCC ID/IC ID can be used only when all FCC/IC compliance requirements are met.

Antenna

- (1) The antenna must be installed such that 20 cm is maintained between the antenna and users,
- (2) The transmitter module may not be co-located with any other transmitter or antenna.

In the event that these conditions cannot be met (for example certain laptop configurations or co-location with another transmitter), then the FCC/IC authorization is no longer considered valid and the FCC ID/IC ID cannot be used on the final product. In these circumstances, the OEM integrator will be responsible for re-evaluating the end product (including the transmitter) and obtaining a separate FCC/IC authorization.

To comply with FCC regulations limiting both maximum RF output power and human exposure to RF radiation, maximum antenna gain (including cable loss) must not exceed

Technology	Frequency Range (MHz)	Antenna Type	Max Peak Gain (dBi)
GSM 850	824 ~ 849	Dipole	6.3
PCS 1900	1850 ~ 1910		11.9
WCDMA Band II	1850 ~ 1910		9.9
WCDMA Band IV	1710 ~ 1755		9.9
WCDMA Band V	824 ~ 849		7.3
LTE Band 2	1850 ~ 1910		9.9
LTE Band 4	1710 ~ 1755		9.9
LTE Band 5	824 ~ 849		7.3
LTE Band 7	2500 ~ 2570		9.9
LTE Band 12	699 ~ 716		6.5
LTE Band 13	777 ~ 787		7.0
LTE Band 25	1850 ~ 1915		9.9
LTE Band 26	814 ~ 849		7.2
LTE Band 38	2570 ~ 2620		9.9
LTE Band 41	2496 ~ 2690		9.9
LTE Band 66	1710 ~ 1780		9.9

Manual Information to the End User

The OEM integrator has to be aware not to provide information to the end user regarding how to install or remove this RF module in the user's manual of the end product which integrates this module. The end user manual shall include all required regulatory information/warning as show in this manual

Federal Communication Commission Interference Statement

This device complies with Part 15 of the FCC Rules. Operation is subject to the following two conditions:

(1) This device may not cause harmful interference, and (2) this device must accept any interference received, including interference that may cause undesired operation.

This equipment has been tested and found to comply with the limits for a Class B digital device, pursuant to Part 15 of the FCC Rules. These limits are designed to provide reasonable protection against harmful interference in a residential installation. This equipment generates, uses and can radiate radio frequency energy and, if not installed and used in accordance with the instructions, may cause harmful interference to radio communications. However, there is no guarantee that interference will not occur in a particular installation. If this equipment does cause harmful interference to radio or television reception, which can be determined by turning the equipment off and on, the user is encouraged to try to correct the interference by one of the following measures:

- Reorient or relocate the receiving antenna.
- Increase the separation between the equipment and receiver
- Connect the equipment into an outlet on a circuit different from that to which the receiver is connected.
- Consult the dealer or an experienced radio/TV technician for help.

Any changes or modifications not expressly approved by the party responsible for compliance could void the user's authority to operate this equipment. This transmitter must not be co-located or operating in conjunction with any other antenna or transmitter.

List of applicable FCC rules

This module has been tested and found to comply with part 22, part 24, part 27, part 90 requirements for Modular Approval.

The modular transmitter is only FCC authorized for the specific rule parts (i.e., FCC transmitter rules) listed on the grant, and that the host product manufacturer is responsible for compliance to any other FCC rules that apply to the host not covered by the modular transmitter grant of certification. If the grantee markets their product as being Part 15 Subpart B compliant (when it also contains unintentional-radiator digital circuitry), then the grantee shall provide a notice stating that the final host product still requires Part 15 Subpart B compliance testing with the modular transmitter installed.

This device is intended only for OEM integrators under the following conditions: (For module device use)

- 1) The antenna must be installed such that 20 cm is maintained between the antenna and users, and
- 2) The transmitter module may not be co-located with any other transmitter or antenna.

As long as 2 conditions above are met, further transmitter test will not be required. However, the OEM integrator is still responsible for testing their end-product for any additional compliance requirements required with this module installed.

Radiation Exposure Statement

This equipment complies with FCC radiation exposure limits set forth for an uncontrolled environment. This equipment should be installed and operated with minimum distance 20 cm between the radiator & your body.

Industry Canada Statement

This device complies with Industry Canada's licence-exempt RSSs. Operation is subject to the following two conditions:

- (1) This device may not cause interference; and
- (2) This device must accept any interference, including interference that may cause undesired operation of the device.

Le présent appareil est conforme aux CNR d'Industrie Canada applicables aux appareils radio exempts de licence. L'exploitation est autorisée aux deux conditions suivantes:

- (1) l'appareil ne doit pas produire de brouillage, et
- (2) l'utilisateur de l'appareil doit accepter tout brouillage radioélectrique subi, même si le brouillage est susceptible d'en compromettre le fonctionnement."

Radiation Exposure Statement

This equipment complies with IC radiation exposure limits set forth for an uncontrolled environment. This equipment should be installed and operated with minimum distance 20 cm between the radiator & your body

Déclaration d'exposition aux radiations:

Cet équipement est conforme aux limites d'exposition aux rayonnements ISED établies pour un environnement non contrôlé. Cet équipement doit être installé et utilisé avec un minimum de 20 cm de distance entre la source de rayonnement et votre corps.

This device is intended only for OEM integrators under the following conditions: (For module device use)

- 1) The antenna must be installed such that 20 cm is maintained between the antenna and users, and
- 2) The transmitter module may not be co-located with any other transmitter or antenna. As long as 2 conditions above are met, further transmitter test will not be required. However, the OEM integrator is still responsible for testing their end-product for any additional compliance requirements required with this module installed.

Cet appareil est conçu uniquement pour les intégrateurs OEM dans les conditions suivantes: (Pour utilisation de dispositif module)

- 1) L'antenne doit être installée de telle sorte qu'une distance de 20 cm est respectée entre l'antenne et les utilisateurs, et
- 2) Le module émetteur peut ne pas être coïmplanté avec un autre émetteur ou antenne.

Tant que les 2 conditions ci-dessus sont remplies, des essais supplémentaires sur l'émetteur ne seront pas nécessaires. Toutefois, l'intégrateur OEM est toujours responsable des essais sur son produit final pour toutes exigences de conformité supplémentaires requis pour ce module installé.

IMPORTANT NOTE:

In the event that these conditions cannot be met (for example certain laptop configurations or colocation with another transmitter), then the Canada authorization is no longer considered valid and the IC ID cannot be used on the final product. In these circumstances, the OEM integrator will be responsible for re-evaluating the end product (including the transmitter) and obtaining a separate Canada authorization.

NOTE IMPORTANTE:

Dans le cas où ces conditions ne peuvent être satisfaites (par exemple pour certaines configurations d'ordinateur portable ou de certaines co-localisation avec un autre émetteur), l'autorisation du Canada n'est plus considéré comme valide et l'ID IC ne peut pas être utilisé sur le produit final. Dans ces circonstances, l'intégrateur OEM sera chargé de réévaluer le produit final (y compris l'émetteur) et l'obtention d'une autorisation distincte au Canada.

End Product Labeling

This transmitter module is authorized only for use in device where the antenna may be installed such that 20 cm may be maintained between the antenna and users. The final end product must be labeled in a visible area with the following: "Contains IC: 10224A-2022EG25GL".

Plaque signalétique du produit final

Ce module émetteur est autorisé uniquement pour une utilisation dans un dispositif où l'antenne peut être installée de telle sorte qu'une distance de 20cm peut être maintenue entre l'antenne et les utilisateurs. Le produit final doit être étiqueté dans un endroit visible avec l'inscription suivante: "Contient des IC: 10224A-2022EG25GL".

Manual Information to the End User

The OEM integrator has to be aware not to provide information to the end user regarding how to install or remove this RF module in the user's manual of the end product which integrates this module.

The end user manual shall include all required regulatory information/warning as show in this manual.

Manuel d'information à l'utilisateur final

L'intégrateur OEM doit être conscient de ne pas fournir des informations à l'utilisateur final quant à la façon d'installer ou de supprimer ce module RF dans le manuel de l'utilisateur du produit final qui intègre ce module.

Le manuel de l'utilisateur final doit inclure toutes les informations réglementaires requises et avertissements comme indiqué dans ce manuel.