

RF MEASUREMENT REPORT

FCC ID: XMR202212EG25GL
Application: Quectel Wireless Solutions Co., Ltd.
Product: LTE CAT4 Module
Model No.: EG25-GL, EG25-GL MINIPCIE
Brand Name: QUECTEL
FCC Rule Part(s): Part 2, 22 (H), 24 (E), 27
Test Procedure(s): ANSI C63.26: 2015
Result: Complies
Received Date: 2022-11-23
Test Date: 2022-11-24 ~ 2023-02-09

Reviewed By:

Sunny Sun

Approved By:

Robin Wu



The test results relate only to the samples tested.

This equipment has been shown to be capable of compliance with the applicable technical standards as indicated in the measurement report and was tested in accordance with the measurement procedures specified in ANSI C63.26-2015. Test results reported herein relate only to the item(s) tested.

The test report shall not be reproduced except in full without the written approval of MRT Technology (Suzhou) Co., Ltd.

Revision History

Report No.	Version	Description	Issue Date	Note
2211RSU065-U1	Rev. 01	Initial Report	2023-02-26	Valid

CONTENTS

Description	Page
1. General Information.....	5
1.1. Applicant	5
1.2. Manufacturer	5
1.3. Testing Facility	5
1.4. Product Information.....	6
1.5. Radio Specification under Testing.....	6
1.6. Description of Available Antennas.....	7
1.7. Test Methodology	7
2. Test Configuration	8
2.1. Test System Connection Diagram	8
2.2. Test Environment Condition	8
3. Measuring Instrument	9
4. Decision Rules and Measurement Uncertainty.....	11
4.1. Decision Rules	11
4.2. Measurement Uncertainty.....	11
5. Test Result.....	12
5.1. Summary.....	12
5.2. Occupied Bandwidth Measurement.....	13
5.2.1. Test Limit.....	13
5.2.2. Test Procedure.....	13
5.2.3. Test Setting	13
5.2.4. Test Setup	13
5.2.5. Test Result	13
5.3. Frequency Stability Measurement	14
5.3.1. Test Limit.....	14
5.3.2. Test Procedure.....	14
5.3.3. Test Setting	14
5.3.4. Test Setup	15
5.3.5. Test Result	15
5.4. Equivalent Isotropically Radiated Power Measurement	16
5.4.1. Test Limit.....	16
5.4.2. Test Procedure.....	16
5.4.3. Test Setting	16
5.4.4. Test Setup	17

5.4.5.	Test Result	17
5.5.	Band Edge Measurement	18
5.5.1.	Test Limit	18
5.5.2.	Test Procedure	18
5.5.3.	Test Setting	18
5.5.4.	Test Setup	19
5.5.5.	Test Result	19
5.6.	Peak to Average Ratio Measurement	20
5.6.1.	Test Limit	20
5.6.2.	Test Procedure	20
5.6.3.	Test Setting	20
5.6.4.	Test Setup	20
5.6.5.	Test Result	20
5.7.	Conducted Spurious Emissions Measurement.....	21
5.7.1.	Test Limit	21
5.7.2.	Test Procedure	21
5.7.3.	Test Setting	21
5.7.4.	Test Setup	22
5.7.5.	Test Result	22
5.8.	Radiated Spurious Emissions Measurement.....	23
5.8.1.	Test Limit	23
5.8.2.	Test Procedure	23
5.8.3.	Test Setting	23
5.8.4.	Test Setup	24
5.8.5.	Test Result	25
Appendix A - Test Result		26
A.1	Occupied Bandwidth Test Result	26
A.2	Frequency Stability Test Result.....	33
A.3	Equivalent Isotropically Radiated Power Test Result.....	38
A.4	Band Edge Test Result	43
A.5	Peak to Average Ratio Test Result	46
A.6	Conducted Spurious Emissions Test Result	54
A.7	Radiated Spurious Emissions Test Result	59
Appendix B - Test Setup Photograph		64
Appendix C - EUT Photograph		65

1.4. Product Information

Product Name	LTE CAT4 Module
Model No.	EG25-GL, EG25-GL MINIPCIE
Brand Name	QUECTEL
IMEI	865061060011919
GNSS Specification	GPS, GLONASS, Galileo, Bei Dou
GSM Band	GSM 850, PCS1900
UMTS Band	Band 2, 4, 5
E-UTRA Band	Band 2, 4, 5, 7, 12, 13, 25, 26, 38, 41, 66
Operating Temperature	-35 ~ 75 °C
Supply Voltage	3.3 ~ 4.3Vdc, typical 3.8Vdc
Remark: 1. The information of EUT was provided by the manufacturer, and the accuracy of the information shall be the responsibility of the manufacturer. 2. The model difference is the different encapsulation, all the other circuits are the same. This report assessed the EG25-GL model.	

1.5. Radio Specification under Testing

GSM Specification	
TX Frequency Range	GSM/GPRS/EDGE: 850: 824 ~ 849MHz 1900: 1850 ~ 1910MHz
RX Frequency Range	GSM/GPRS/EDGE: 850: 869 ~ 894MHz 1900: 1930 ~ 1990MHz
Modulation	GMSK, 8-PSK
Power Class	GSM850: 4, DCS1900: 1
Category	Multi-slot class 33
UMTS Specification	
TX Frequency Range:	WCDMA Band II: 1850 ~ 1910MHz, WCDMA Band IV: 1710 ~ 1755MHz WCDMA Band V: 824 ~ 849MHz
RX Frequency Range:	WCDMA Band II: 1930 ~ 1990MHz, WCDMA Band IV: 2110 ~ 2155MHz WCDMA Band V: 869 ~ 894MHz
Modulation	QPSK, 16QAM, 64QAM
Power Class	3
Category	HSDPA: 24; HSUPA: 6

1.6. Description of Available Antennas

Technology	Frequency Range (MHz)	Antenna Type	MaxPeak Gain (dBi)
GSM 850	824 ~ 849	Dipole	2.13
PCS 1900	1850 ~ 1910		1.38
WCDMA Band II	1850 ~ 1910		1.38
WCDMA Band IV	1710 ~ 1755		2.00
WCDMA Band V	824 ~ 849		2.13

Note: All antenna information (Antenna type and Peak Gain) is provided by the manufacturer.

1.7. Test Methodology

According to the specifications of the manufacturer, the EUT must comply with the requirements of the following standards:

- ANSI C63.26:2015
- FCC CFR 47 Part 2, 22, 24, 27
- FCC KDB 971168 D01 v03r01: Power Meas License Digital Systems
- FCC KDB 971168 D02 v02r01: Misc Rev Approv License Devices
- FCC KDB 412172 D01 v01r01: Determining ERP and EIRP

2. Test Configuration

2.1. Test System Connection Diagram

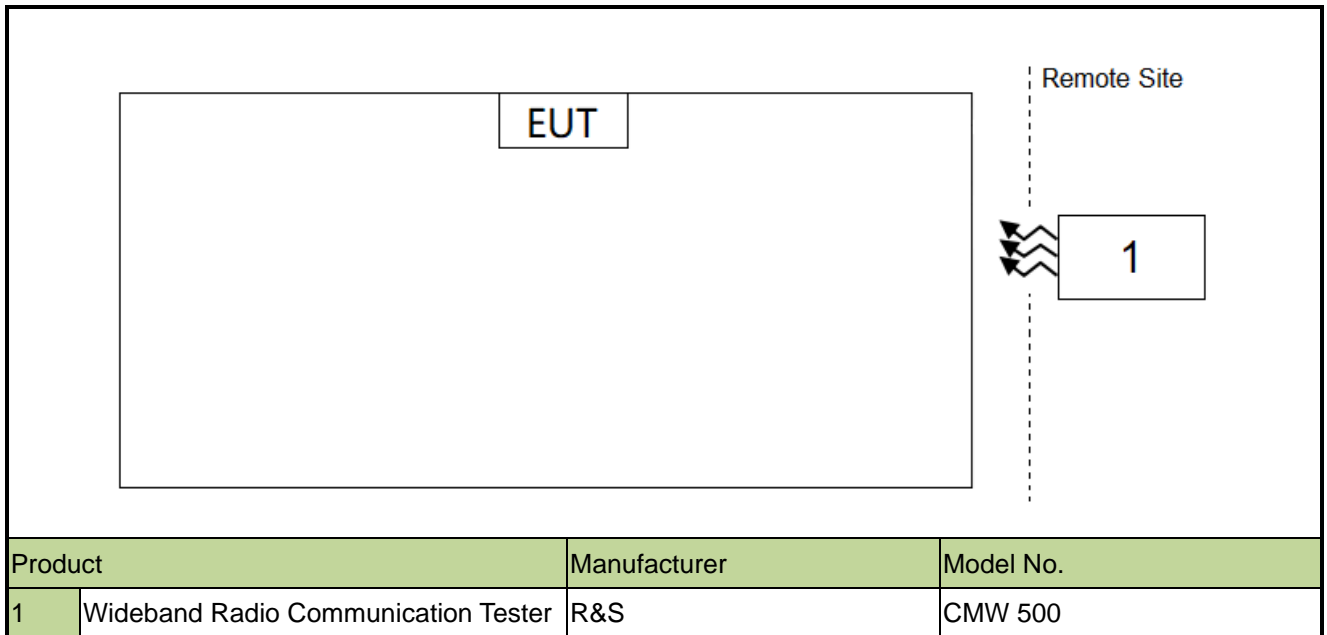

2.2. Test Environment Condition

Ambient Temperature	15 ~ 35°C
Relative Humidity	20% ~ 75%RH

3. Measuring Instrument

Instrument	Manufacturer	Model No.	Asset No.	Cali. Interval	Cali. Due Date	Test Site
Communication Tester	R&S	CMU 200	MRTSUE06009	1 year	2023-08-23	SIP-SR1
Communication Tester	R&S	CMW500	MRTSUE06243	1 year	2023-10-08	SIP-SR1 SIP-AC1
Signal Generator	Keysight	E8257D	MRTSUE06453	1 year	2023-06-01	SIP-SR1
Thermohygrometer	testo	622	MRTSUE06629	1 year	2023-01-06	SIP-SR1
Thermohygrometer	testo	622	MRTSUE06629	1 year	2024-01-03	SIP-SR1
5G Wireless Test Platform	Keysight	E7515B	MRTSUE06903	1 year	2023-10-25	SIP-SR1
Signal Generator	Keysight	E8257D	MRTSUE06904	1 year	2023-10-25	SIP-SR1
DC POWER MODULE	Keysight	N6743B	MRTSUE06905	N/A	N/A	SIP-SR1
DC POWER MODULE	Keysight	N6743B	MRTSUE06906	N/A	N/A	SIP-SR1
Low-Profile Modular Power System Mainframe	Keysight	N6700C	MRTSUE06907	N/A	N/A	SIP-SR1
FR1 Switching Unit	Keysight	C8880A	MRTSUE06908	N/A	N/A	SIP-SR1
Signal Analyzer	Keysight	N9021B	MRTSUE06915	1 year	2022-12-29	SIP-SR1
Signal Analyzer	Keysight	N9021B	MRTSUE06915	1 year	2023-12-28	SIP-SR1
Temperature Chamber	BAOYT	BYG-80CL	MRTSUE06932	1 year	2023-02-27	SIP-SR1
Shielding Room	MIX-BEP	SIP-SR1	MRTSUE06948	N/A	N/A	SIP-SR1
Directional Coupler	PULSAR	CS10-23-436/20	MRTSUE06846	1 year	2023-06-02	SIP-SR1
Directional Coupler	PULSAR	CS10-23-436/20	MRTSUE06848	1 year	2023-06-02	SIP-SR1
Attenuator	MVE	MVE2213	MRTSUE11055	1 year	2023-06-09	SIP-SR1
Attenuator	MVE	MVE2213	MRTSUE11056	1 year	2023-06-09	SIP-SR1
Attenuator	MVE	MVE2213	MRTSUE11057	1 year	2023-06-09	SIP-SR1
Attenuator	MVE	MVE2213	MRTSUE11058	1 year	2023-06-09	SIP-SR1
Attenuator	MVE	MVE2213	MRTSUE11059	1 year	2023-06-09	SIP-SR1
Attenuator	MVE	MVE2213	MRTSUE11060	1 year	2023-06-09	SIP-SR1
Anechoic Chamber	RIKEN	SIP-AC1	MRTSUE06554	1 year	2022-12-23	SIP-AC1
Anechoic Chamber	RIKEN	SIP-AC1	MRTSUE06554	1 year	2023-12-22	SIP-AC1
Preamplifier	EMCI	EMC051845SE	MRTSUE06600	1 year	2023-11-07	SIP-AC1
Horn Antenna	R&S	HF907	MRTSUE06610	1 year	2023-07-13	SIP-AC1
Thermohygrometer	testo	608-H1	MRTSUE06616	1 year	2023-11-01	SIP-AC1
Thermohygrometer	testo	608-H1	MRTSUE06620	1 year	2022-11-28	SIP-AC1
Thermohygrometer	testo	608-H1	MRTSUE06620	1 year	2023-11-27	SIP-AC1
TRILOG Antenna	Schwarzbeck	VULB 9168	MRTSUE06645	1 year	2023-07-30	SIP-AC1
Thermohygrometer	testo	608-H1	MRTSUE06362	1 year	2023-02-15	WZ-SR6
Shielding Room	HUAMING	WZ-SR6	MRTSUE06443	N/A	N/A	WZ-SR6

Signal Analyzer	Keysight	N9020B	MRTSUE06583	1 year	2023-10-08	WZ-SR6
Signal Generator	Keysight	N5173B	MRTSUE06606	1 year	2022-11-26	WZ-SR6
Signal Generator	Keysight	N5173B	MRTSUE06606	1 year	2023-11-25	WZ-SR6
5G Wireless Test Platform	Keysight	E7515B	MRTSUE06942	1 year	2023-03-03	WZ-SR6
Thermohygrometer	testo	608-H1	MRTSUE06362	1 year	2023-02-15	WZ-SR6
Temperature Chamber	BAOYT	BYH-150CL	MRTSUE06051	1 year	2023-10-08	WZ-TR3
Vibration Test System	DongLing	ES-1-150	MRTSUE06206	1 year	2023-07-07	WZ-TR3
Thermohygrometer	testo	608-H1	MRTSUE06401	1 year	2023-06-06	WZ-TR3
Radio Communication Analyzer	Anritsu	MT8821C	MRTSUE06960	1 year	2023-07-08	WZ-SR6/WZ-TR3
Communication Tester	R&S	CMW500	MRTSUE06108	1 year	2022-11-26	WZ-SR6/WZ-TR3
Communication Tester	R&S	CMW500	MRTSUE06108	1 year	2023-11-25	WZ-SR6/WZ-TR3
Attenuator	MVE	MVE2213	MRTSUE11094	1 year	2023-06-09	WZ
Attenuator	MVE	MVE2213	MRTSUE11095	1 year	2023-06-09	WZ
Attenuator	MVE	MVE2213	MRTSUE11096	1 year	2023-06-09	WZ

Software	Version	Function
EMI V3	V 3.0.0	EMI Test Software
Controller_MF 7802BS	1.02	RE Antenna & Turntable

4. Decision Rules and Measurement Uncertainty

4.1. Decision Rules

The Decision Rule is based on Simple Acceptance in accordance with ISO Guide 98-4: 2012 Clause 8.2. (Measurement uncertainty is not taken into account when stating conformity with a specified requirement.)

4.2. Measurement Uncertainty

Where relevant, the following test uncertainty levels have been estimated for tests performed on the EUT as specified in CISPR 16-4-2. This uncertainty represents an expanded uncertainty expressed at approximately the 95% confidence level using a coverage factor of $k = 2$.

Radiated Spurious Emissions
Measurement Uncertainty for a Level of Confidence of 95% ($U=2Uc(y)$): Horizontal: 9kHz ~ 300MHz: 5.04dB 300MHz ~ 1GHz: 4.95dB 1GHz ~ 40GHz: 6.40dB Vertical: 9kHz ~ 300MHz: 5.24dB 300MHz ~ 1GHz: 6.03dB 1GHz ~ 40GHz: 6.40dB
Conducted Spurious Emissions
Measuring Uncertainty for a Level of Confidence of 95% ($U=2Uc(y)$): 0.78dB
Output Power
Measuring Uncertainty for a Level of Confidence of 95% ($U=2Uc(y)$): 1.13dB
Occupied Bandwidth
Measuring Uncertainty for a Level of Confidence of 95% ($U=2Uc(y)$): 0.28%
Frequency Stability
Measuring Uncertainty for a Level of Confidence of 95% ($U=2Uc(y)$): 76.2Hz

5. Test Result

5.1. Summary

FCC Part Section(s)	Test Description	Test Condition	Verdict
2.1049	Occupied Bandwidth	Conducted	Pass
2.1055, 22.355 24.235, 27.54	Frequency Stability		Pass
22.913(a)(5), 27.50(d)(4) 24.232(c)	Equivalent (Isotropic) Radiated Power		Pass
2.1051, 22.917(a) 24.238(a), 27.53(h)	Band Edge		Pass
2.1051, 22.917(a) 24.238(a), 27.53(h)	Spurious Emission		
22.913(d), 24.232(d) 27.50(d)(5)	Peak to Average Ratio		Pass
2.1053, 22.917(a) 24.238(a), 27.53(h)	Spurious Emissions	Radiated	Pass

Notes:

- 1) The analyzer plots shown in this section were all taken with a correction table loaded into the analyzer. The correction table was used to account for the losses of the cables and attenuators used as part of the system to connect the EUT to the analyzer at all frequencies of interest.
- 2) All supported modulation types were evaluated. The worst-case emission of modulation was selected. The power of EGPRS/HSDPA/HSUPA is lower than that of GPRS 1Tx Slot/WCDMA. Therefore, the Frequency Stability, Channel Band Edge, Radiated & Conducted Spurious Emission were presented worst-case in the test report.
- 3) For radiated emission tests, every axis (X, Y, Z) was also verified. The test results shown in the following sections represent the worst-case emissions.

5.2. Occupied Bandwidth Measurement

5.2.1. Test Limit

The occupied bandwidth, that is the frequency bandwidth such that, below its lower and above its upper frequency limits, the mean powers radiated are each equal to 0.5 percent of the total mean power radiated by a given emission shall be measured.

5.2.2. Test Procedure

ANSI C63.26-2015 - Section 5.4

5.2.3. Test Setting

1. Set center frequency to the nominal EUT channel center frequency
2. RBW = The nominal RBW shall be in the range of 1% to 5% of the anticipated OBW
3. VBW $\geq 3 \times$ RBW
4. Detector = Peak
5. Trace mode = max hold
6. Sweep = auto couple
7. Allow the trace to stabilize
8. Use the 99% power bandwidth function of the instrument and report the measured bandwidth.

5.2.4. Test Setup

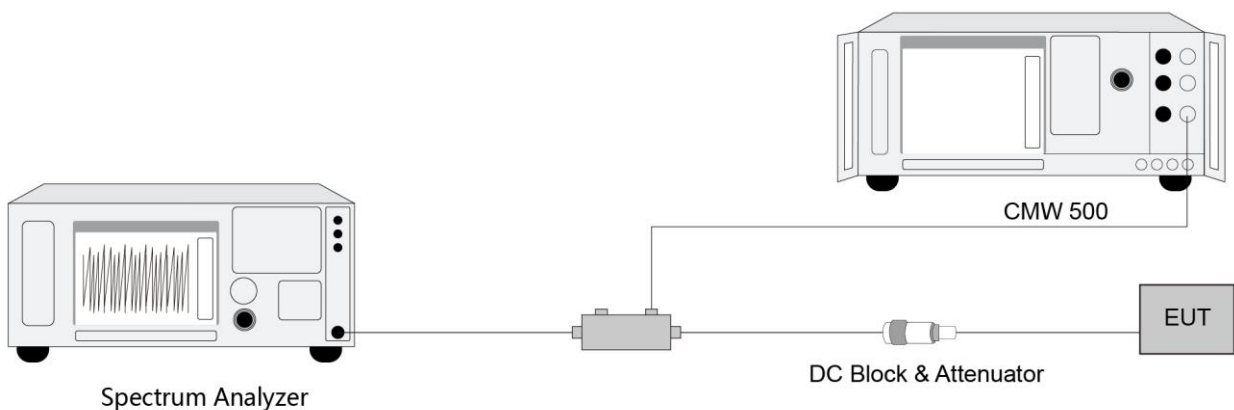

5.2.5. Test Result

Refer to Appendix A.1.

5.3. Frequency Stability Measurement

5.3.1. Test Limit

The frequency stability shall be measured by variation of ambient temperature and variation of primary supply voltage to ensure that the fundamental emission stays within the authorized frequency block. The frequency stability of the transmitter shall be maintained within $\pm 0.00025\%$ ($\pm 2.5\text{ppm}$) of the center frequency.

5.3.2. Test Procedure

ANSI C63.26-2015 - Section 5.6

5.3.3. Test Setting

Frequency Stability Under Temperature Variations:

The equipment under test was connected to an external AC or DC power supply and input rated voltage. RF output was connected to a frequency counter or spectrum analyzer via feed through attenuators. The EUT was placed inside the temperature chamber. Set the spectrum analyzer RBW low enough to obtain the desired frequency resolution and measure EUT 20°C operating frequency as reference frequency. Turn EUT off and set the chamber temperature to High. After the temperature stabilized for approximately 30 minutes recorded the frequency. Repeat step measure with 10°C decreased per stage until the Low temperature reached.

Frequency Stability Under Voltage Variations:

Set chamber temperature to 20°C. Use a variable AC power supply / DC power source to power the EUT and set the voltage to rated voltage. Set the spectrum analyzer RBW low enough to obtain the desired frequency resolution and recorded the frequency.

Reduce the input voltage to specify extreme voltage variation ($\pm 15\%$) and endpoint, record the maximum frequency change.

5.3.4. Test Setup

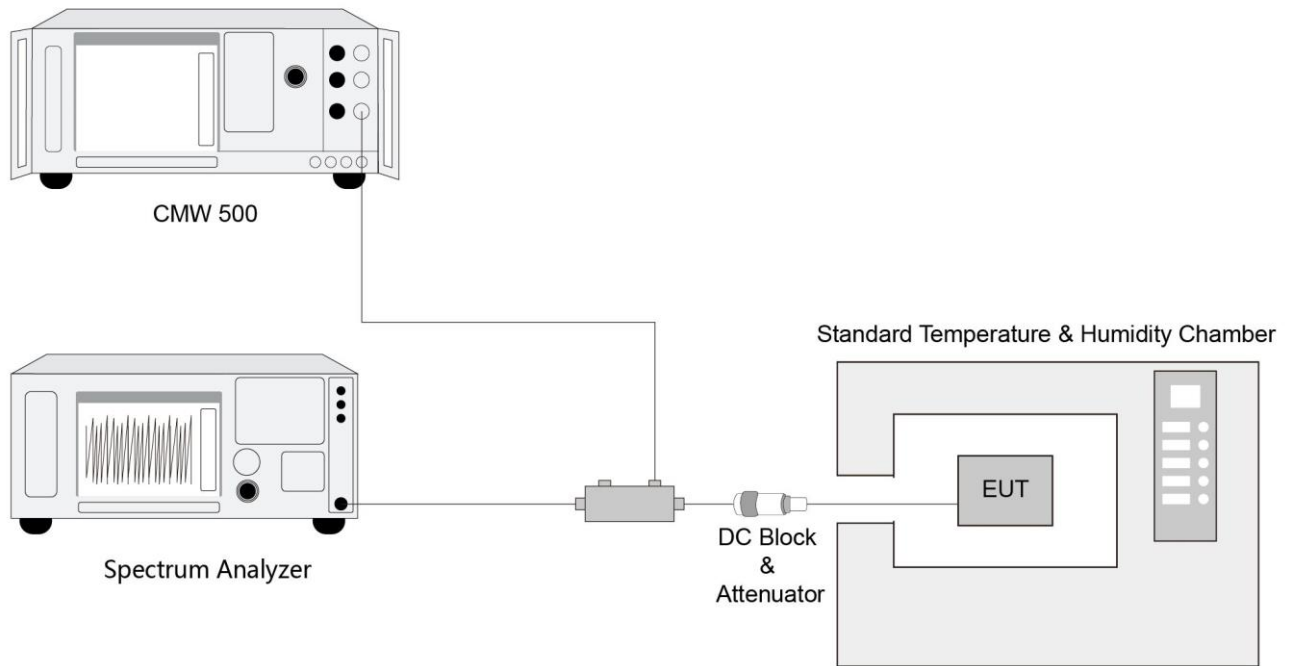

5.3.5. Test Result

Refer to Appendix A.2.

5.4. Equivalent Isotropically Radiated Power Measurement

5.4.1. Test Limit

WCDMA Band II, PCS1900:

Mobile and portable stations are limited to 2 watts EIRP and the equipment must employ a means for limiting power to the minimum necessary for successful communications.

WCDMA Band IV:

Fixed, mobile, and portable (hand-held) stations operating in the 1710-1755 MHz band and mobile and portable stations operating in the 1695-1710 MHz and 1755-1780 MHz bands are limited to 1 watt EIRP.

WCDMA Band V, GSM850:

The ERP of mobile transmitters and auxiliary test transmitters must not exceed 7 watts.

5.4.2. Test Procedure

ANSI C63.26-2015 - Section 5.2

5.4.3. Test Setting

Average power measurements were performed only when the EUT was transmitting at its maximum power control level using a broadband power meter with a pulse sensor. The power meter implemented triggering and gating capabilities which were set up such that power measurements were recorded only during the ON time of the transmitter.

The relevant equation for determining the maximum ERP or EIRP from the measured RF output power is given in Equation (1) as follows:

$$\text{ERP or EIRP} = P_{\text{Meas}} + G_{\text{T}}$$

where

ERP or EIRP effective radiated power or equivalent isotropically radiated power, respectively (expressed in the same units as P_{Meas} , e.g., dBm or dBW)

P_{Meas} measured transmitter output power or PSD, in dBm or dBW

G_{T} gain of the transmitting antenna, in dBd (ERP) or dBi (EIRP)

$$\text{ERP} = \text{EIRP} - 2.15$$

5.4.4. Test Setup



5.4.5. Test Result

Refer to Appendix A.3.

5.5. Band Edge Measurement

5.5.1. Test Limit

For operations in the 824 ~ 849 MHz, 1850 ~ 1910 MHz and 1710 ~ 1755 MHz, the FCC limit is $43 + 10\log_{10}(P_{\text{Watts}})$ dB below the transmitter power P(Watts) in a 1 MHz bandwidth. However, in the 1MHz bands immediately outside and adjacent to the licensee's frequency block, a resolution bandwidth of at least one percent of the emission bandwidth of the fundamental emission of the transmitter may be employed.

5.5.2. Test Procedure

ANSI C63.26-2015 - Section 5.7

5.5.3. Test Setting

1. Set the analyzer frequency to low or high channel
2. $RBW \geq$ The nominal RBW shall be in the range of 1% of the anticipated OBW (in the 1MHz band immediately outside and adjacent to the band edge). For improvement of the accuracy in the measurement of the average power of a noise-like emission, a RBW narrower than the specified reference bandwidth can be used (generally limited to no less than 1% of the OBW), provided that a subsequent integration is performed over the full required measurement bandwidth. This integration should be performed using the spectrum analyzer's band power functions.
3. $VBW \geq 3*RBW$
4. Sweep time = auto
5. Detector = power averaging (rms)
6. Set sweep trigger to "free run."
7. User gate triggered such that the analyzer only sweeps when the device is transmitting at full power
8. Trace average at least 100 traces in power averaging (rms) mode if sweep is set to auto-couple. To accurately determine the average power over the on and off time of the transmitter, it can be necessary to increase the number of traces to be averaged above 100, or if using a manually configured sweep time, increase the sweep time.

5.5.4. Test Setup

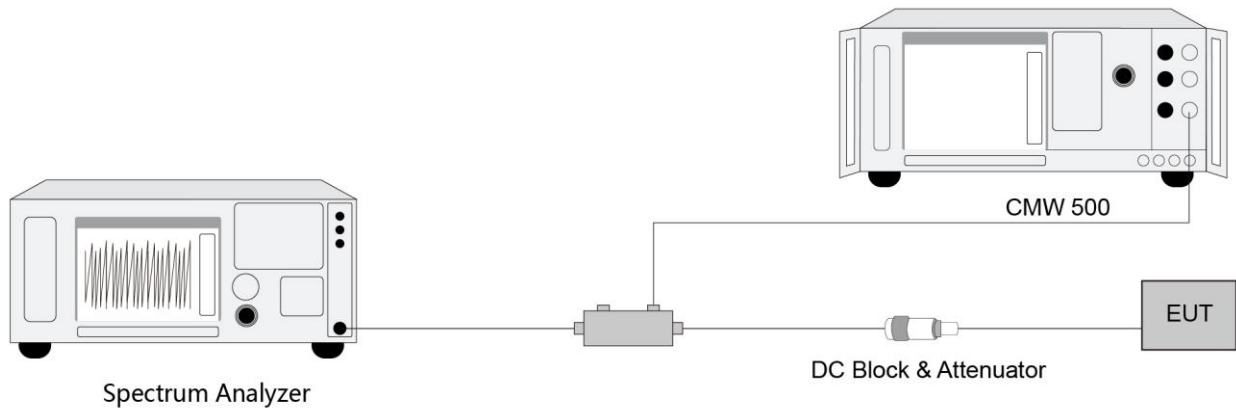

5.5.5. Test Result

Refer to Appendix A.4.

5.6. Peak to Average Ratio Measurement

5.6.1. Test Limit

A peak to average ratio measurement is performed at the conducted port of the EUT. The spectrum analyzers Complementary Cumulative Distribution Function (CCDF) measurement profile is used to determine the largest deviation between the average and the peak power of the EUT in a given bandwidth. The CCDF curve shows how much time the peak waveform spends at or above a given average power level. The percent of time the signal spends at or above the level defines the probability for that particular power level.

5.6.2. Test Procedure

ANSI C63.26-2015 - Section 5.2.3.4 (CCDF).

5.6.3. Test Setting

1. Set the resolution / measurement bandwidth \geq signal's occupied bandwidth
2. Set the number of counts to a value that stabilizes the measured CCDF curve
3. Record the maximum PARR level associated with a probability of 0.1%

5.6.4. Test Setup

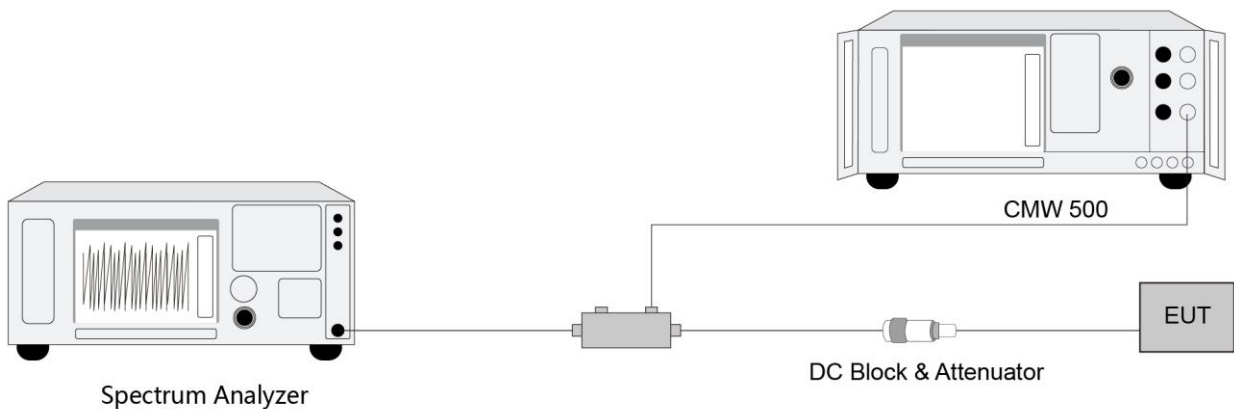

5.6.5. Test Result

Refer to Appendix A.5.

5.7. Conducted Spurious Emissions Measurement

5.7.1. Test Limit

The level of the carrier and the various conducted spurious and harmonic frequencies is measured by means of a calibrated spectrum analyzer. The spectrum is scanned from the Low frequency generated in the equipment up to a frequency including its 10th harmonic. All out of band emissions are measured with a spectrum analyzer connected to the antenna terminal of the EUT while the EUT is operating at its maximum duty cycle, at maximum power, and at the appropriate frequencies. All data rates were investigated to determine the worst-case configuration. All modes of operation were investigated and the worst-case configuration results are reported in this section.

The power of any emission outside of the authorized operating frequency ranges must be attenuated below the transmitting power (P) by a factor of at least $43 + 10 \log(P)$ dB.

5.7.2. Test Procedure

ANSI C63.26-2015 - Section 5.7

5.7.3. Test Setting

1. Set the analyzer frequency to low, mid, high channel.
2. RBW = 1MHz
3. VBW $\geq 3 \cdot$ RBW
4. Sweep time = auto
5. Detector = power averaging (rms)
6. Set sweep trigger to "free run."
7. User gate triggered such that the analyzer only sweeps when the device is transmitting at full power.
8. Trace average at least 100 traces in power averaging (rms) mode if sweep is set to auto-couple. To accurately determine the average power over the on and off time of the transmitter, it can be necessary to increase the number of traces to be averaged above 100, or if using a manually configured sweep time, increase the sweep time.

5.7.4. Test Setup

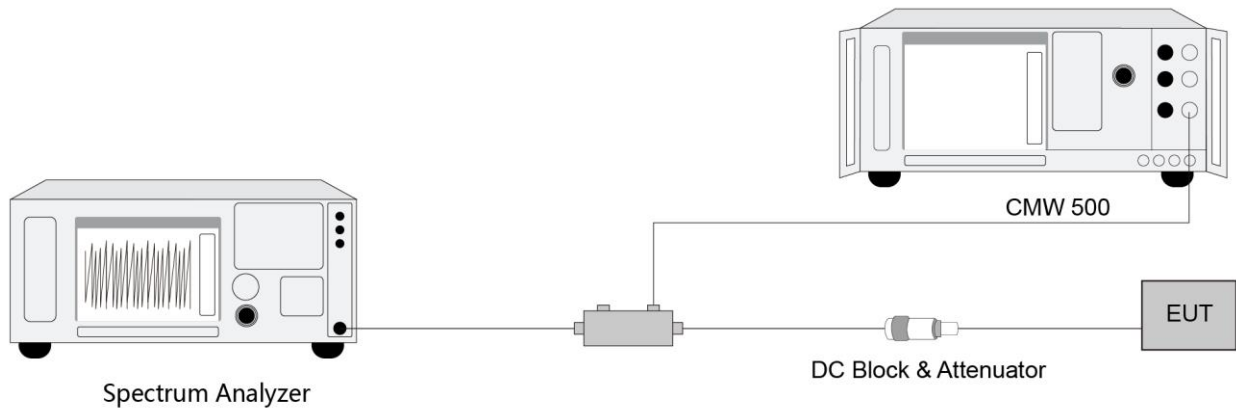

5.7.5. Test Result

Refer to Appendix A.6.

5.8. Radiated Spurious Emissions Measurement

5.8.1. Test Limit

Out of band emissions: The power of any emission outside of the authorized operating frequency ranges must be attenuated below the transmitting power (P) by a factor of at least $43 + 10 \log(P)$ dB. The emission limit equal to -13dBm.

E (dB μ V/m) = EIRP (dBm) - 20 log D + 104.8; where D is the measurement distance in meters. The emission limit equal to 82.3dB μ V/m.

5.8.2. Test Procedure

ANSI C63.26-2015 - Section 5.2.7 & 5.5

5.8.3. Test Setting

1. RBW = 1MHz
2. VBW \geq 3*RBW
3. Sweep time \geq 10 \times (number of points in sweep) \times (transmission symbol period)
4. Detector = Peak
5. Trace mode = max hold
6. The trace was allowed to stabilize

5.8.4. Test Setup

Below 1GHz Test Setup:

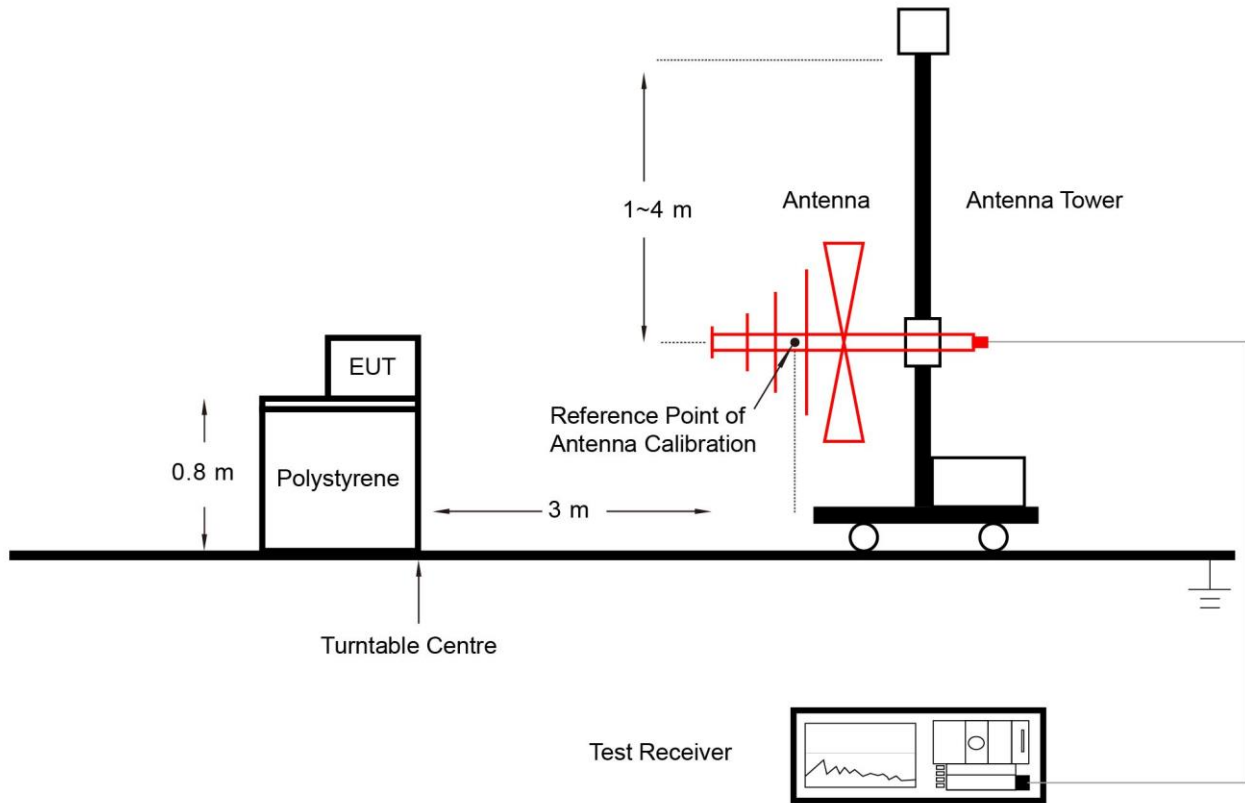

Above 1GHz Test Setup:

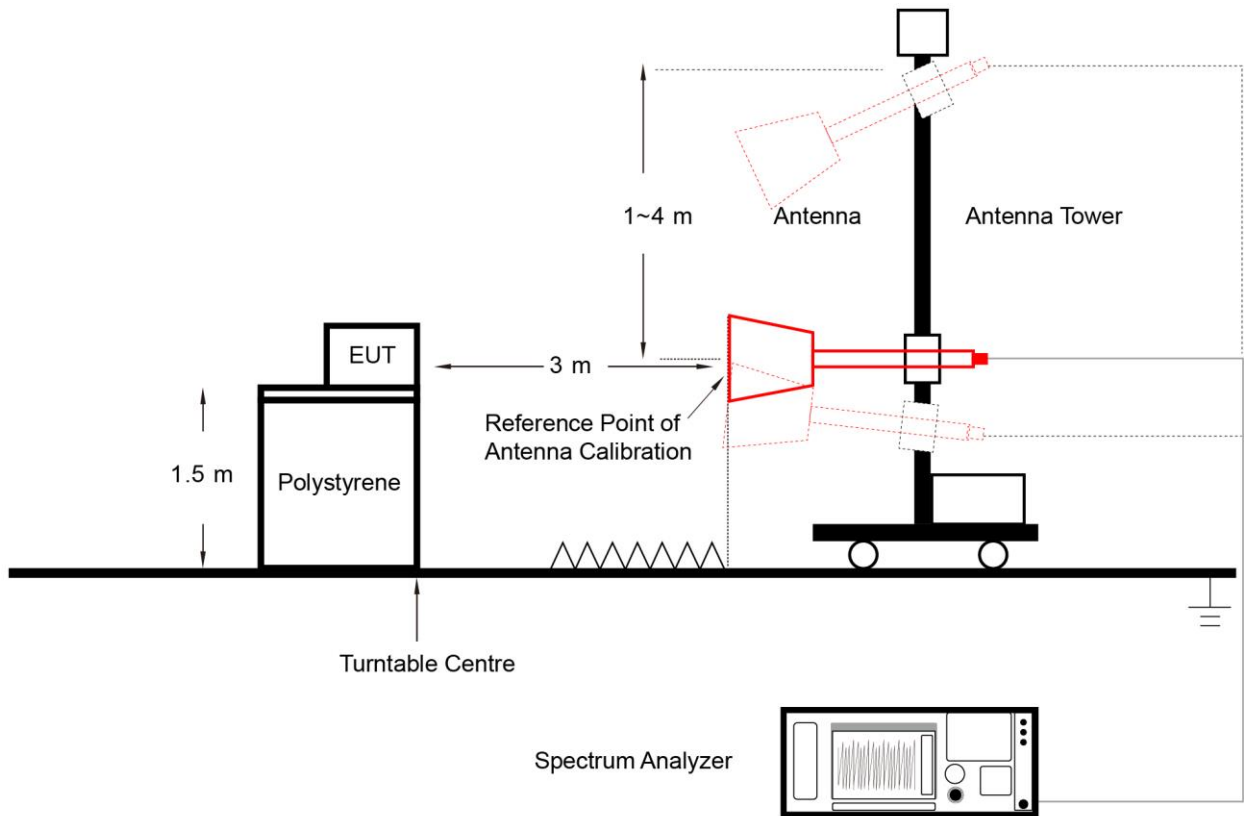

5.8.5. Test Result

Refer to Appendix A.7.

Appendix A - Test Result

A.1 Occupied Bandwidth Test Result

Test Site	SIP-SR1	Test Engineer	Allen Zou
Test Date	2022/12/08	Test Band	GSM 850_GPRS

Channel	Frequency (MHz)	99% Bandwidth (MHz)
Low	824.2	0.243
Middle	836.4	0.244
High	848.8	0.244

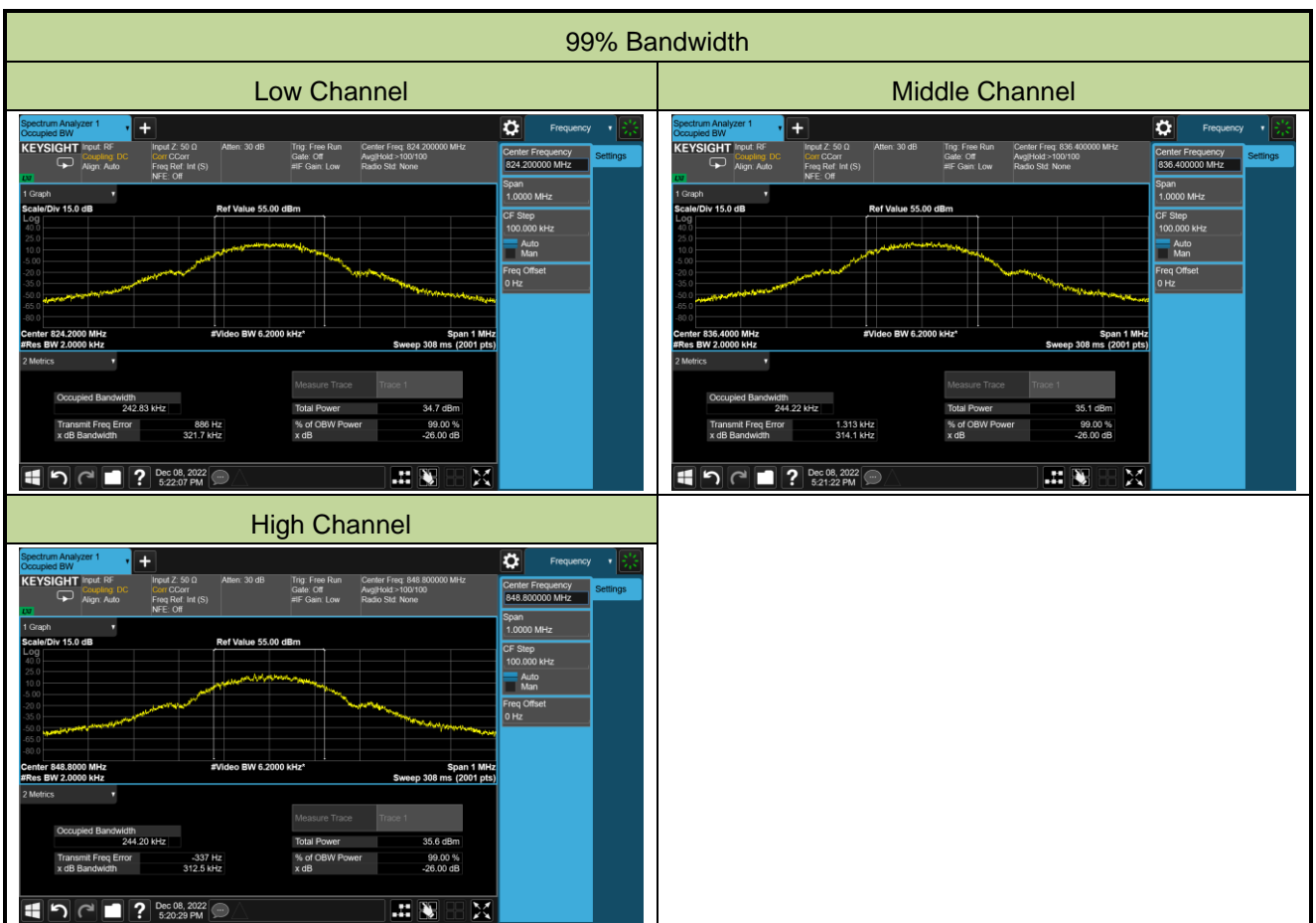

Test Site	SIP-SR1	Test Engineer	Allen Zou
Test Date	2022/12/08	Test Band	GSM 850_EGPRS

Channel	Frequency (MHz)	99% Bandwidth (MHz)
Low	824.2	0.244
Middle	836.4	0.244
High	848.4	0.247

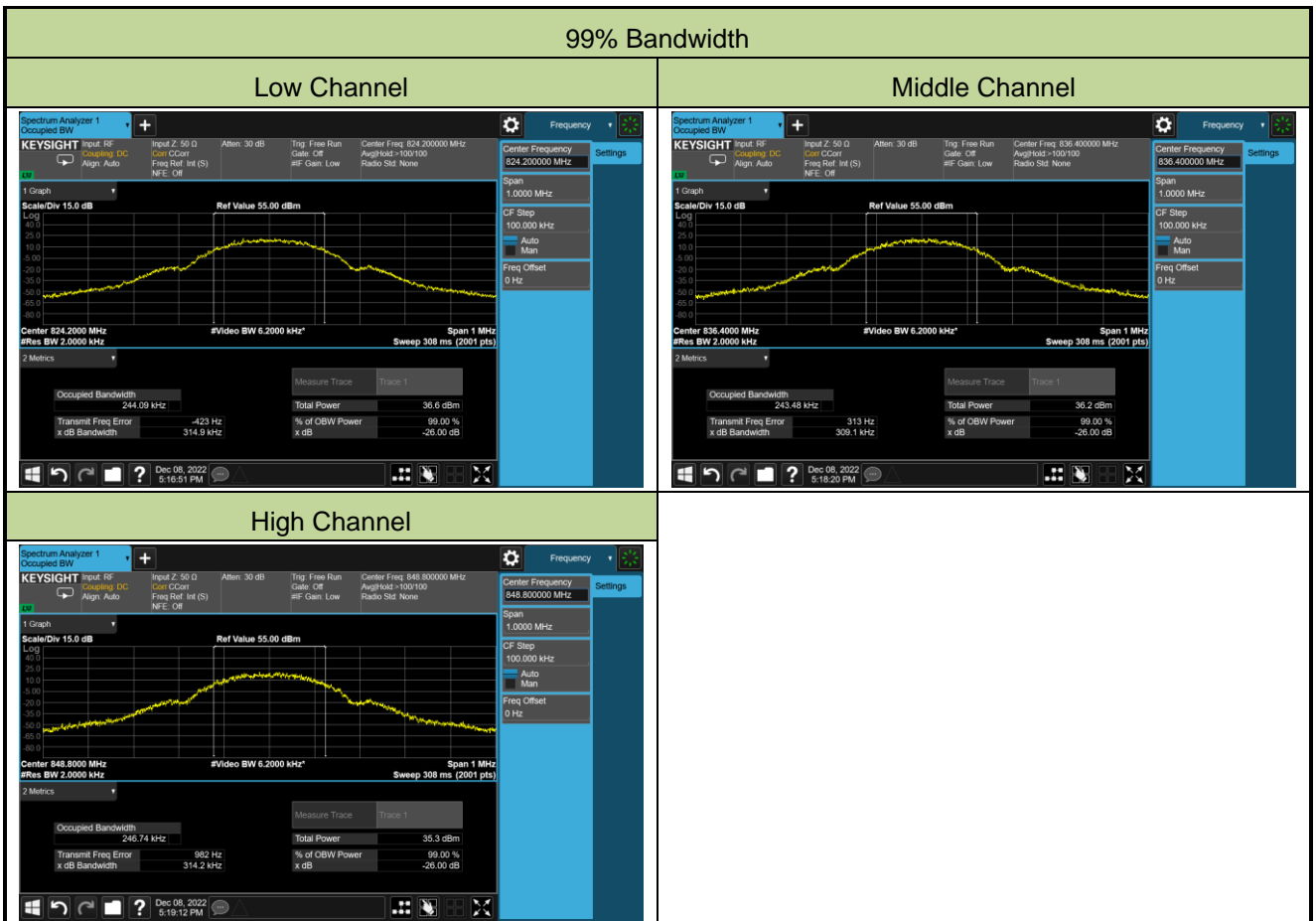

Test Site	SIP-SR1	Test Engineer	Allen Zou
Test Date	2022/12/08	Test Band	PCS 1900_GPRS

Channel	Frequency (MHz)	99% Bandwidth (MHz)
Low	1850.2	0.244
Middle	1880.0	0.244
High	1909.8	0.245

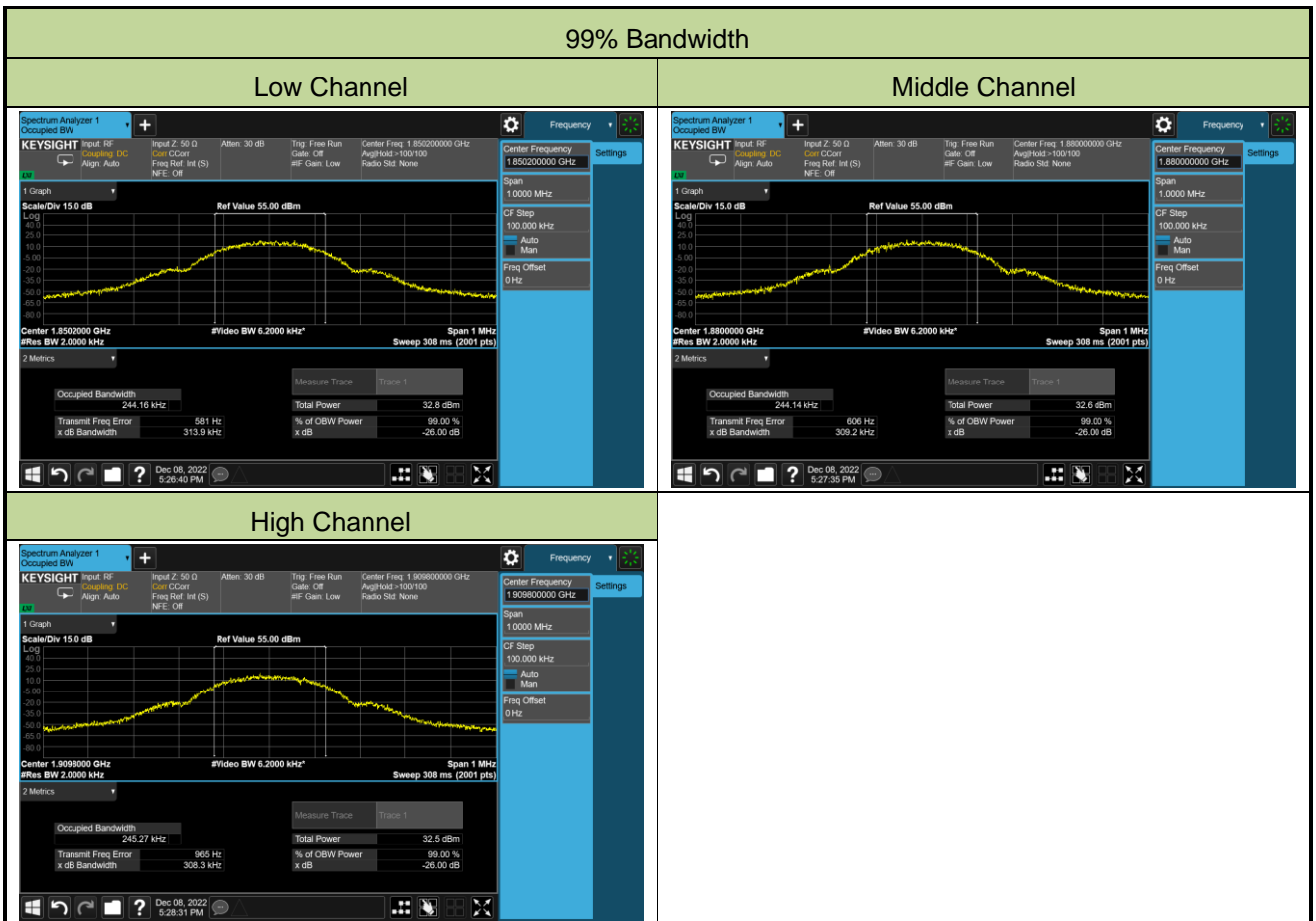

Test Site	SIP-SR1	Test Engineer	Allen Zou
Test Date	2022/12/08	Test Band	PCS 1900_EGPRS

Channel	Frequency (MHz)	99% Bandwidth (MHz)
Low	1850.2	0.245
Middle	1880.0	0.245
High	1909.8	0.246

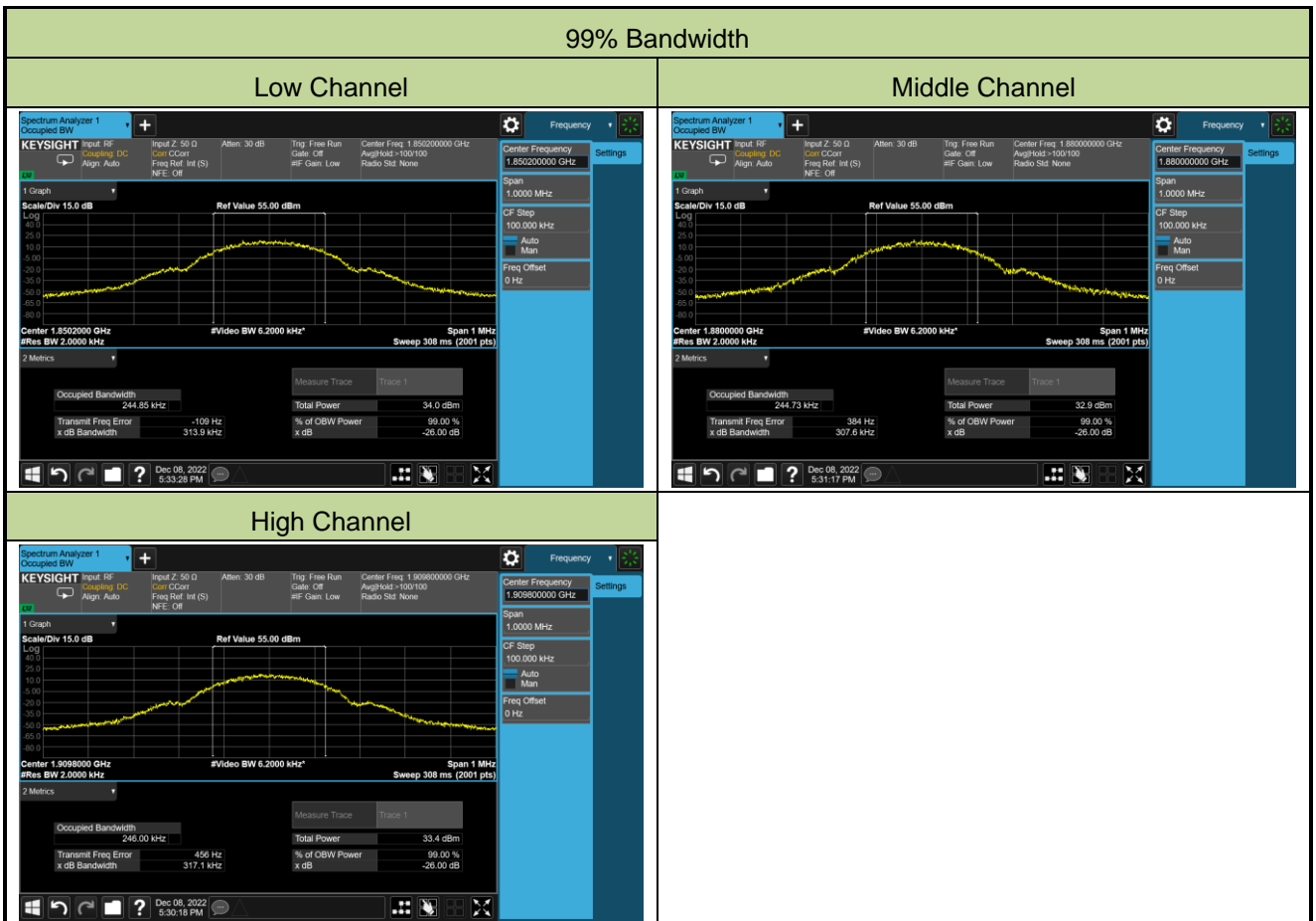

Test Site	WZ-SR6	Test Engineer	Cloud Guo
Test Date	2022/12/09	Test Band	WCDMA Band II

Channel	Frequency (MHz)	99% Bandwidth (MHz)
Low	1852.4	4.12
Middle	1880.0	4.12
High	1907.6	4.12



Test Site	WZ-SR6	Test Engineer	Cloud Guo
Test Date	2022/12/09	Test Band	WCDMA Band IV

Channel	Frequency (MHz)	99% Bandwidth (MHz)
Low	1712.4	4.12
Middle	1732.4	4.13
High	1752.6	4.12

99% Bandwidth

Low Channel	Middle Channel
<p>Low Channel</p> <p>Center Frequency: 1.712400000 GHz</p> <p>Occupied BW: 4.1174 MHz</p> <p>Total Power: 32.1 dBm</p>	<p>Middle Channel</p> <p>Center Frequency: 1.740000000 GHz</p> <p>Occupied BW: 4.1251 MHz</p> <p>Total Power: 32.1 dBm</p>
<p>High Channel</p> <p>Center Frequency: 1.752600000 GHz</p> <p>Occupied BW: 4.1212 MHz</p> <p>Total Power: 32.1 dBm</p>	Empty space for the fourth quadrant

Test Site	WZ-SR6	Test Engineer	Cloud Guo
Test Date	2022/12/09	Test Band	WCDMA Band V

Channel	Frequency (MHz)	99% Bandwidth (MHz)
Low	826.4	4.13
Middle	836.4	4.12
High	846.6	4.12



A.2 Frequency Stability Test Result

Test Site	SIP-SR1	Test Engineer	Allen Zou
Test Date	2022/12/08	Test Band	GSM 850_GPRS

Power (Vdc)	Temp. (°C)	Frequency Tolerance (ppm)
3.80	- 30	0.0007
	- 20	0.0078
	- 10	0.0022
	0	0.0080
	+ 10	0.0055
	+ 20 (Ref)	0.0000
	+ 30	0.0088
	+ 40	0.0121
	+ 50	0.0098
4.30	+ 20	0.0040
3.30	+ 20	0.0088

Test Site	SIP-SR1	Test Engineer	Allen Zou
Test Date	2022/12/08	Test Band	PCS 1900_GPRS

Power (Vdc)	Temp. (°C)	Frequency Tolerance (ppm)
3.80	- 30	0.0107
	- 20	0.0010
	- 10	0.0021
	0	0.0034
	+ 10	0.0013
	+ 20 (Ref)	0.0000
	+ 30	0.0057
	+ 40	0.0043
	+ 50	0.0048
4.30	+ 20	0.0015
3.30	+ 20	0.0019

Test Site	WZ-TR3	Test Engineer	Cloud Guo
Test Date	2022/11/29	Test Band	WCDMA Band II

Power (Vdc)	Temp. (°C)	Frequency Tolerance (ppm)
3.80	- 30	0.0064
	- 20	-0.0008
	- 10	0.0028
	0	0.0004
	+ 10	-0.0007
	+ 20 (Ref)	0.0000
	+ 30	-0.0019
	+ 40	-0.0009
	+ 50	-0.0002
4.30	+ 20	-0.0018
3.30	+ 20	-0.0012

Test Site	WZ-TR3	Test Engineer	Cloud Guo
Test Date	2022/11/29	Test Band	WCDMA Band IV

Power (Vdc)	Temp. (°C)	Frequency Tolerance (ppm)
3.80	- 30	0.0106
	- 20	0.0102
	- 10	0.0111
	0	0.0102
	+ 10	0.0078
	+ 20 (Ref)	0.0000
	+ 30	0.0002
	+ 40	-0.0010
	+ 50	-0.0021
4.30	+ 20	-0.0005
3.30	+ 20	0.0012

Test Site	WZ-TR3	Test Engineer	Cloud Guo
Test Date	2022/11/29	Test Band	WCDMA Band V

Power (Vdc)	Temp. (°C)	Frequency Tolerance (ppm)
3.80	- 30	0.0113
	- 20	0.0049
	- 10	0.0043
	0	-0.0001
	+ 10	-0.0012
	+ 20 (Ref)	0.0000
	+ 30	-0.0022
	+ 40	-0.0019
	+ 50	-0.0018
4.30	+ 20	-0.0020
3.30	+ 20	-0.0012

A.3 Equivalent Isotropically Radiated Power Test Result

Test Site	WZ-SR6	Test Engineer	Cloud Guo
Test Date	2022/12/15	Test Band	GSM 850

Mode	Slot	Conducted Power (dBm)			Antenna Gain (dBi)	ERP (dBm)		
		GSM 850 Channel				GSM 850 Channel		
		128	189	251	128	189	251	
GSM	/	32.21	32.65	32.89	2.13	32.19	32.63	32.87
GPRS	1	32.26	32.62	32.93	2.13	32.24	32.60	32.91
	2	30.61	31.05	31.42	2.13	30.59	31.03	31.40
	3	29.08	29.55	30.01	2.13	29.06	29.53	29.99
	4	27.95	28.51	28.93	2.13	27.93	28.49	28.91
EGPRS (GMSK)	1	32.20	32.61	32.89	2.13	32.18	32.59	32.87
	2	30.57	31.07	31.48	2.13	30.55	31.05	31.46
	3	29.38	29.92	30.32	2.13	29.36	29.90	30.30
	4	28.24	28.47	28.94	2.13	28.22	28.45	28.92
EGPRS (8PSK)	1	26.05	26.50	26.91	2.13	26.03	26.48	26.89
	2	24.97	25.41	25.79	2.13	24.95	25.39	25.77
	3	23.38	23.91	24.26	2.13	23.36	23.89	24.24
	4	22.26	22.67	23.01	2.13	22.24	22.65	22.99
Limit	38.45dBm							

Note: The ERP (dBm) = Output Power (dBm) + Antenna Gain (dBi) - 2.15

Test Site	WZ-SR6	Test Engineer	Cloud Guo
Test Date	2022/12/15	Test Band	PCS 1900

Mode	Slot	Conducted Power (dBm)			Antenna Gain (dBi)	EIRP (dBm)		
		PCS 1900 Channel				PCS 1900 Channel		
		512	661	810	512	661	810	
GSM	/	29.49	30.04	29.88	1.38	30.87	31.42	31.26
GPRS	1	29.50	30.06	29.89	1.38	30.88	31.44	31.27
	2	28.66	29.16	29.13	1.38	30.04	30.54	30.51
	3	27.04	27.10	27.90	1.38	28.42	28.48	29.28
	4	26.53	26.57	26.72	1.38	27.91	27.95	28.10
EGPRS (GMSK)	1	29.54	30.08	29.87	1.38	30.92	31.46	31.25
	2	29.05	29.15	29.13	1.38	30.43	30.53	30.51
	3	27.06	27.09	27.90	1.38	28.44	28.47	29.28
	4	26.53	26.57	26.67	1.38	27.91	27.95	28.05
EGPRS (8PSK)	1	26.23	26.25	26.31	1.38	27.61	27.63	27.69
	2	25.65	25.63	25.71	1.38	27.03	27.01	27.09
	3	24.34	24.38	24.52	1.38	25.72	25.76	25.90
	4	23.18	23.09	23.18	1.38	24.56	24.47	24.56
Limit	33.01dBm							

Note: The EIRP (dBm) = Output Power (dBm) + Antenna Gain (dBi)

Test Site	WZ-SR6	Test Engineer	Cloud Guo
Test Date	2022/12/08	Test Band	WCDMA Band II

Mode	3GPP Subtest	Conducted Power (dBm)			Antenna Gain (dBi)	EIRP (dBm)		
		Band II Channel				Band II Channel		
		9262	9400	9538		9262	9400	9538
WCDMA R99	1	24.26	24.36	24.46	1.38	25.64	25.74	25.84
HSDPA	1	23.35	23.37	23.49	1.38	24.73	24.75	24.87
	2	23.37	23.50	23.50	1.38	24.75	24.88	24.88
	3	22.87	23.00	23.01	1.38	24.25	24.38	24.39
	4	22.87	23.00	23.01	1.38	24.25	24.38	24.39
HSUPA	1	23.04	23.11	23.13	1.38	24.42	24.49	24.51
	2	22.39	22.43	22.43	1.38	23.77	23.81	23.81
	3	22.04	22.02	22.04	1.38	23.42	23.40	23.42
	4	22.58	22.62	22.63	1.38	23.96	24.00	24.01
	5	23.37	23.41	23.47	1.38	24.75	24.79	24.85
Limit	33.01dBm							

Note: The EIRP (dBm) = Output Power (dBm) + Antenna Gain (dBi)

Test Site	WZ-SR6	Test Engineer	Cloud Guo
Test Date	2022/12/08	Test Band	WCDMA Band IV

Mode	3GPP Subtest	Conducted Power (dBm)			Antenna Gain (dBi)	EIRP (dBm)		
		Band IV Channel				Band IV Channel		
		1312	1412	1513		1312	1412	1513
WCDMA R99	1	23.93	23.97	23.96	2.00	25.93	25.97	25.96
HSDPA	1	23.08	23.04	23.07	2.00	25.08	25.04	25.07
	2	23.08	23.04	23.02	2.00	25.08	25.04	25.02
	3	22.60	22.55	22.54	2.00	24.60	24.55	24.54
	4	22.59	22.55	22.54	2.00	24.59	24.55	24.54
HSUPA	1	22.68	22.49	22.51	2.00	24.68	24.49	24.51
	2	21.95	22.01	21.95	2.00	23.95	24.01	23.95
	3	21.60	21.61	21.58	2.00	23.60	23.61	23.58
	4	22.20	22.20	22.17	2.00	24.20	24.20	24.17
	5	23.03	23.03	23.03	2.00	25.03	25.03	25.03
Limit	30.00dBm							

Note: The EIRP (dBm) = Output Power (dBm) + Antenna Gain (dBi)

Test Site	WZ-SR6	Test Engineer	Cloud Guo
Test Date	2022/12/08	Test Band	WCDMA Band V

Mode	3GPP Subtest	Conducted Power (dBm)			Antenna Gain (dBi)	ERP (dBm)		
		Band V Channel				Band V Channel		
		4132	4182	4233		4132	4182	4233
WCDMA R99	1	23.73	23.79	23.55	2.13	23.71	23.77	23.53
HSDPA	1	22.65	22.73	22.52	2.13	22.63	22.71	22.50
	2	22.68	22.75	22.52	2.13	22.66	22.73	22.50
	3	22.21	22.28	22.05	2.13	22.19	22.26	22.03
	4	22.21	22.29	22.05	2.13	22.19	22.27	22.03
HSUPA	1	22.35	22.46	22.23	2.13	22.33	22.44	22.21
	2	21.13	21.30	20.98	2.13	21.11	21.28	20.96
	3	20.72	20.83	20.60	2.13	20.70	20.81	20.58
	4	22.10	22.26	22.03	2.13	22.08	22.24	22.01
	5	22.64	22.70	22.47	2.13	22.62	22.68	22.45
Limit	38.45dBm							

Note: The ERP (dBm) = Output Power (dBm) + Antenna Gain (dBi) – 2.15

A.4 Band Edge Test Result

Test Site	WZ-SR6	Test Engineer	Cloud Guo
Test Date	2023/02/09	Test Band	GSM 850

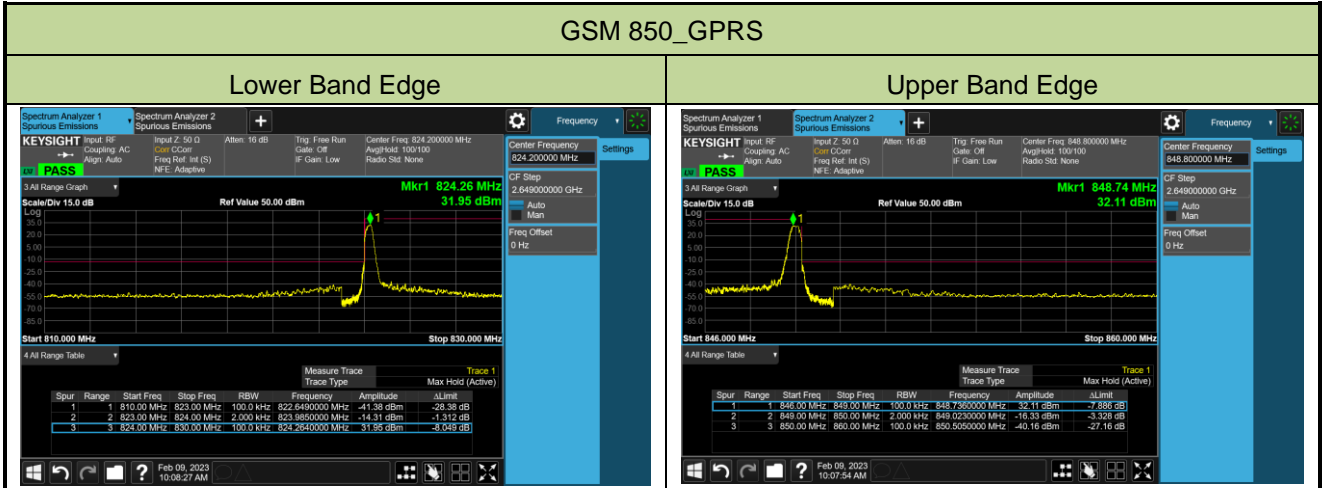

Test Site	SIP-SR1	Test Engineer	Allen Zou
Test Date	2022/12/08	Test Band	PCS 1900

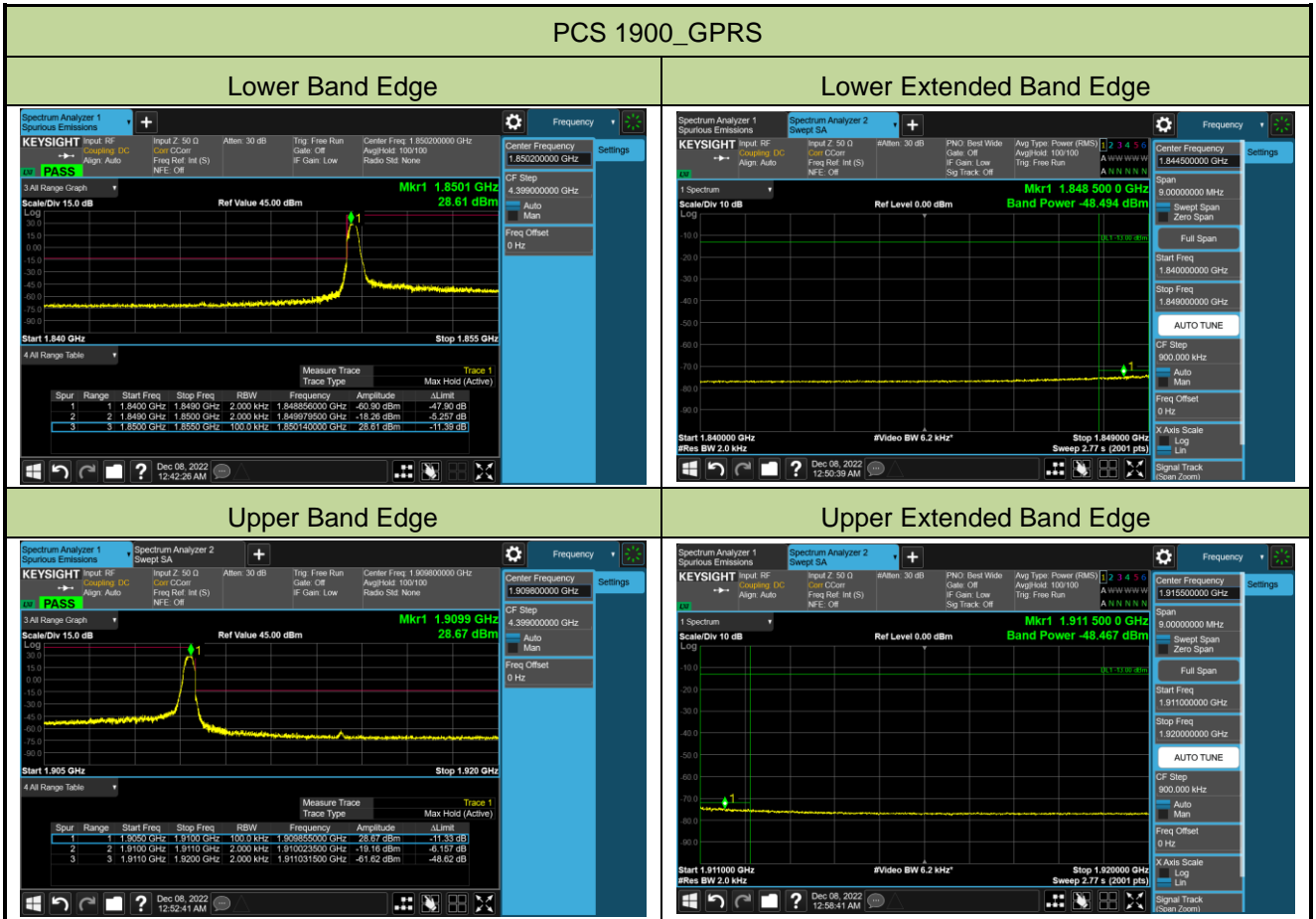

Test Site	WZ-SR6	Test Engineer	Cloud Guo
Test Date	2022/11/28	Test Band	WCDMA Band II, IV, V

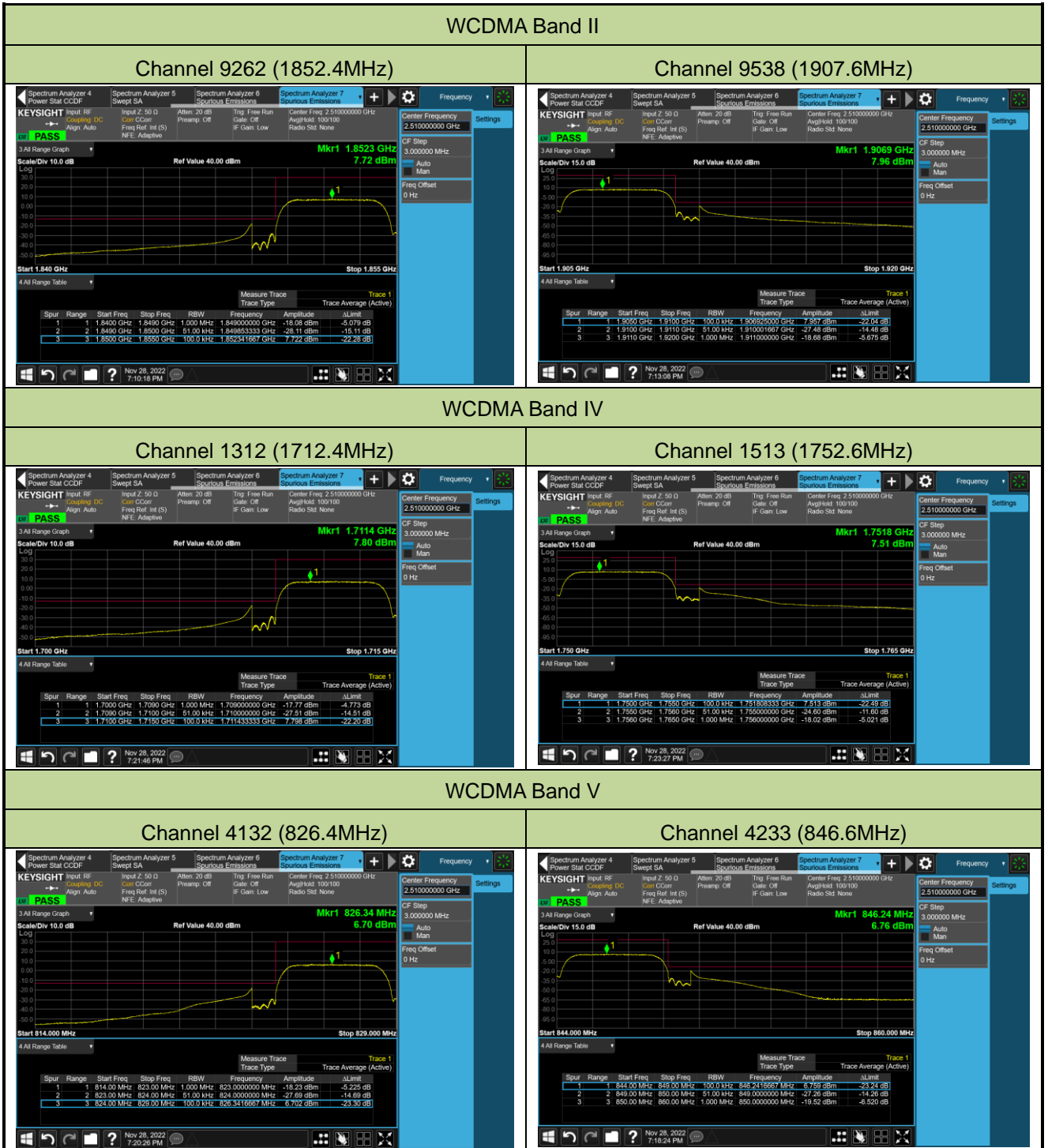

A.5 Peak to Average Ratio Test Result

Test Site	SIP-SR1	Test Engineer	Allen Zou
Test Date	2022/12/08	Test Band	GSM 850, PCS 1900

Channel No.	Frequency (MHz)	Channel Bandwidth (kHz)	Peak to Average Ratio (dB)	Limit (dB)	Result
GSM 850_GPRS					
128	824.2	200	2.73	≤ 13.00	Pass
189	836.4	200	2.75	≤ 13.00	Pass
251	848.8	200	2.77	≤ 13.00	Pass
GSM 850_EGPRS					
128	824.2	200	2.73	≤ 13.00	Pass
189	836.4	200	2.75	≤ 13.00	Pass
251	848.8	200	2.77	≤ 13.00	Pass
PCS 1900_GPRS					
512	1850.2	200	2.73	≤ 13.00	Pass
661	1880.0	200	2.76	≤ 13.00	Pass
810	1909.8	200	2.77	≤ 13.00	Pass
PCS 1900_EGPRS					
512	1850.2	200	2.72	≤ 13.00	Pass
661	1880.0	200	2.76	≤ 13.00	Pass
810	1909.8	200	2.77	≤ 13.00	Pass

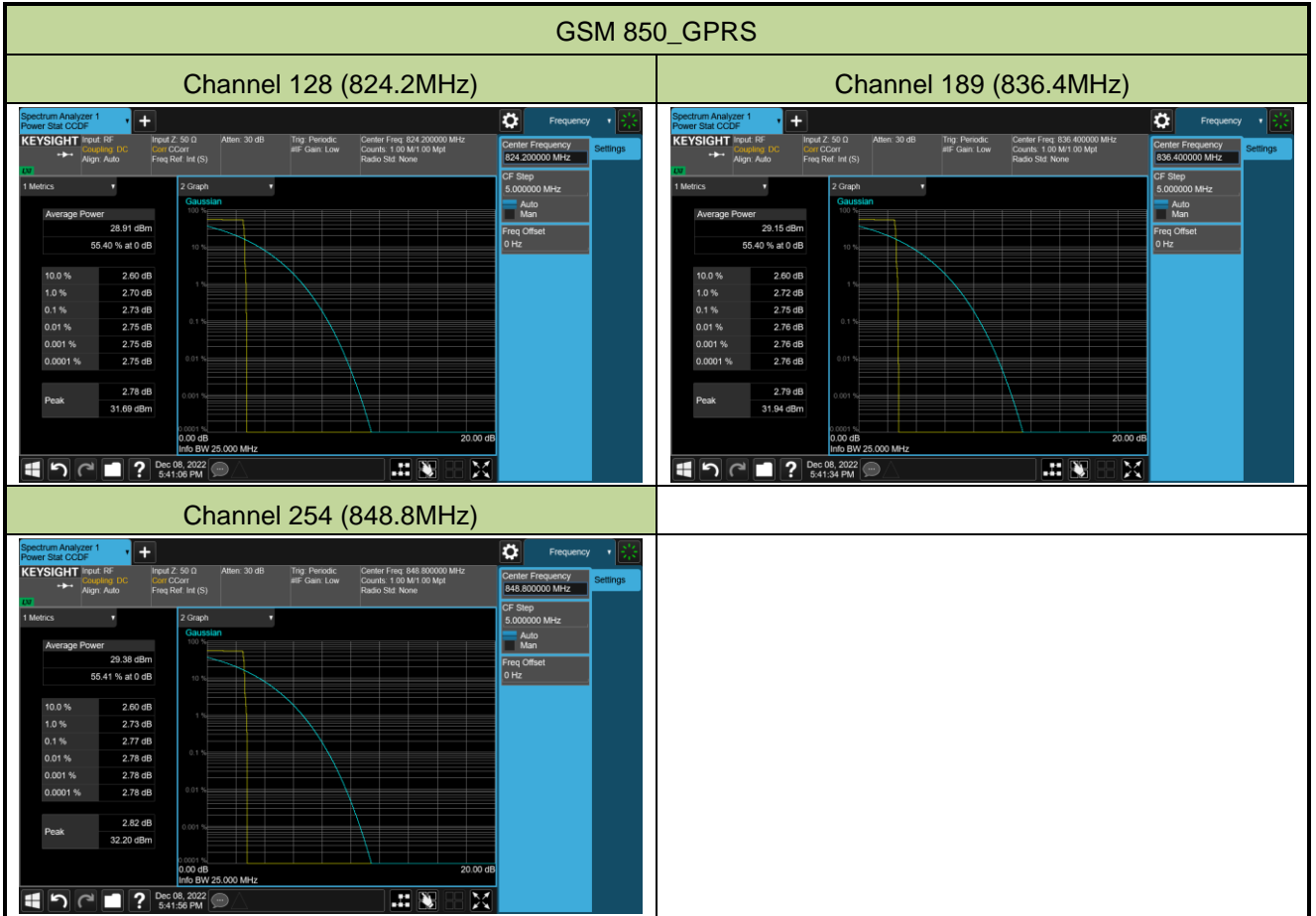

GSM 850_EGPRS

Channel 128 (824.2MHz)

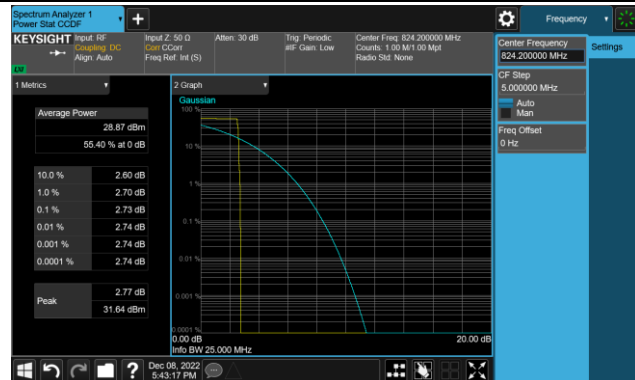

Channel 189 (836.4MHz)



Channel 254 (848.8MHz)

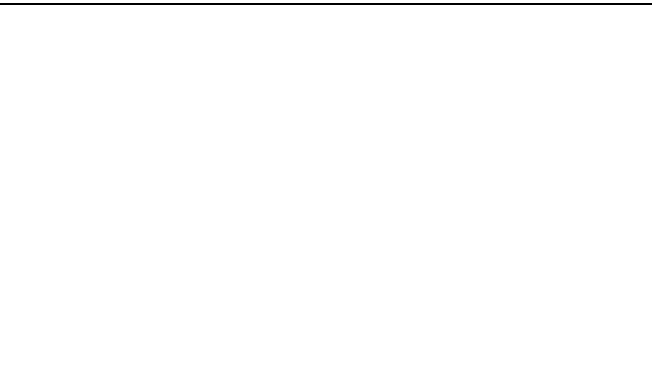
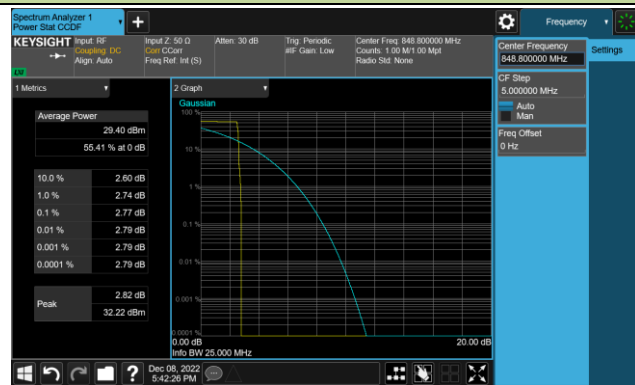

PCS 1900_GPRS

Channel 512 (1850.2MHz)

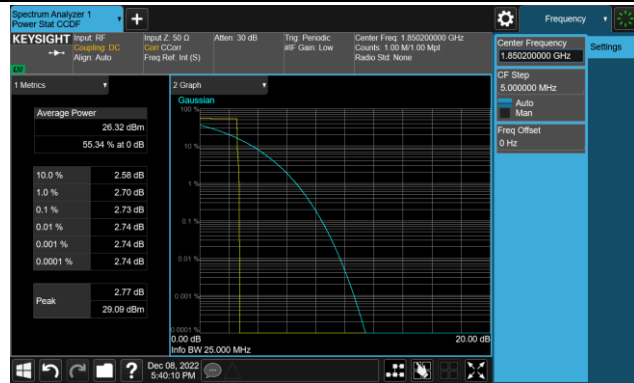

Channel 661 (1880.0MHz)

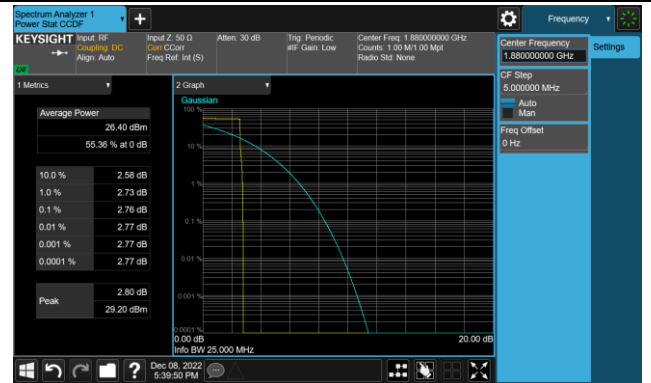

Channel 810 (1909.8MHz)

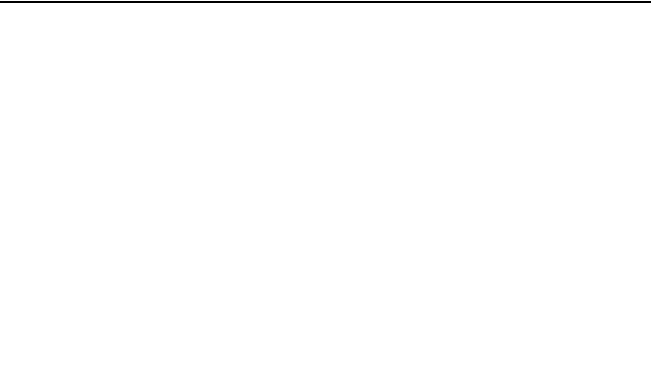
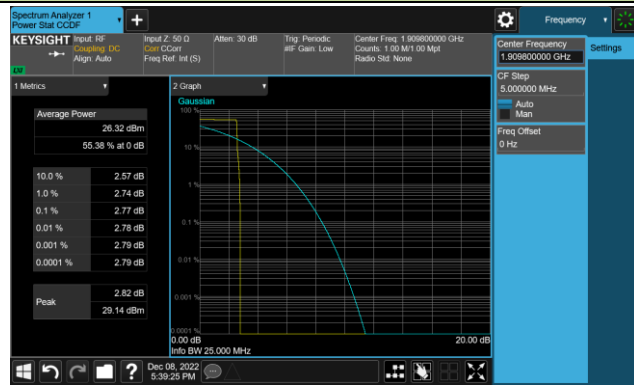

PCS 1900_EGPRS

Channel 512 (1850.2MHz)

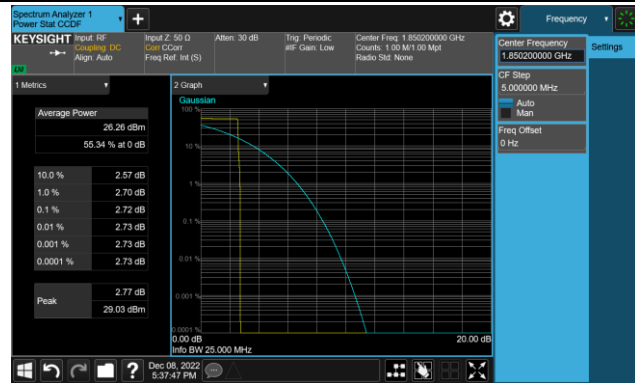

Channel 661 (1880.0MHz)

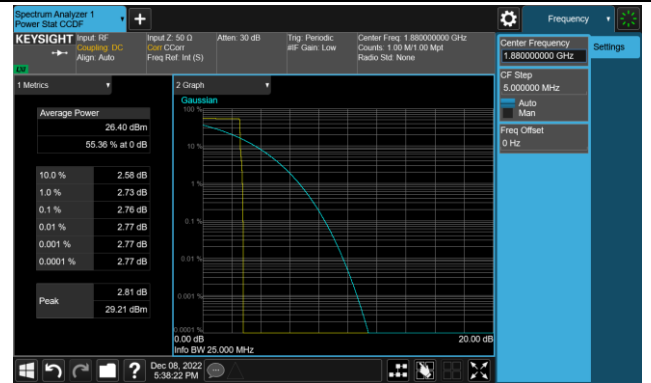

Channel 810 (1909.8MHz)

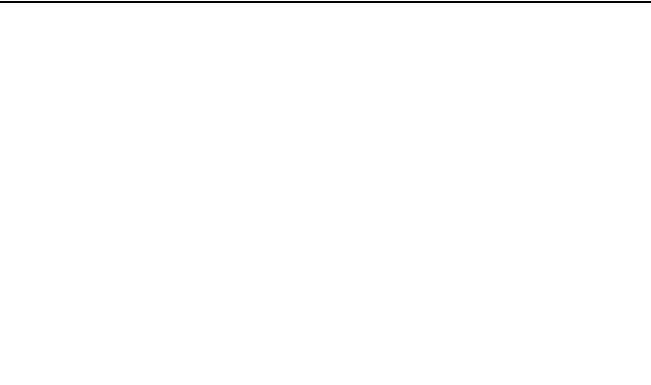
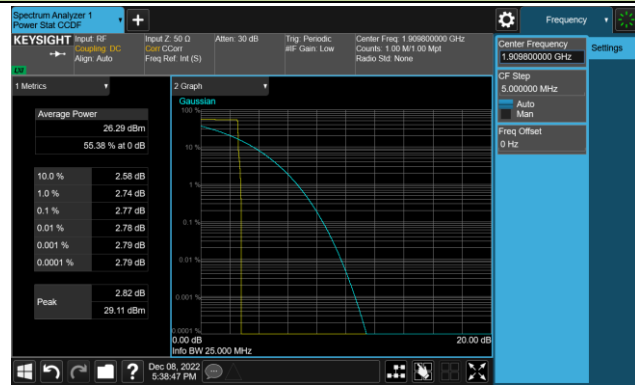

Test Site	WZ-SR6	Test Engineer	Cloud Guo
Test Date	2022/12/09	Test Band	WCDMA Band II, IV, V

Frequency (MHz)	Channel Bandwidth (MHz)	Peak to Average Ratio (dB)	Limit (dB)	Result
1852.5	5	3.49	≤ 13.00	Pass
1880.0	5	3.49	≤ 13.00	Pass
1907.6	5	3.46	≤ 13.00	Pass
1712.4	5	3.29	≤ 13.00	Pass
1732.4	5	3.29	≤ 13.00	Pass
1752.6	5	3.18	≤ 13.00	Pass
826.4	5	3.25	≤ 13.00	Pass
836.4	5	3.36	≤ 13.00	Pass
846.6	5	3.17	≤ 13.00	Pass

WCDMA Band II

Channel 9262 (1852.4MHz)

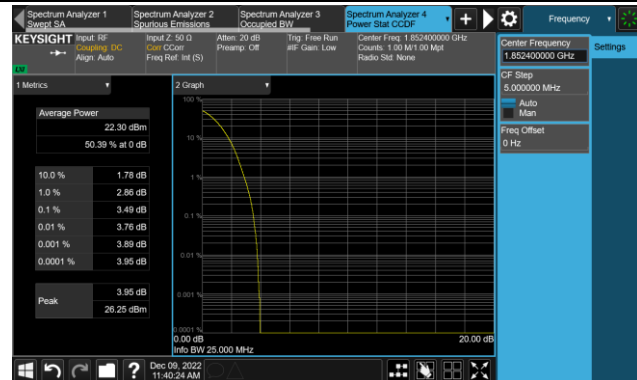

Channel 9400 (1880.0MHz)

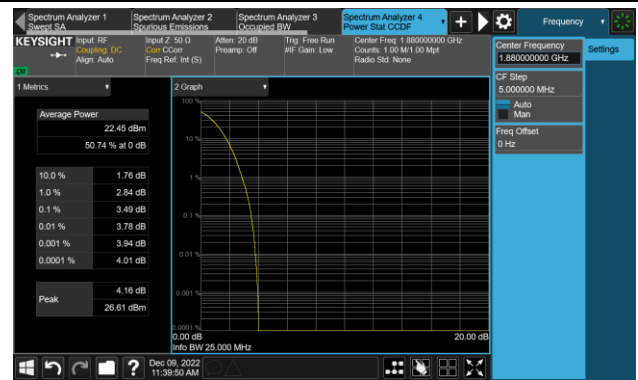

Channel 9538 (1907.6MHz)

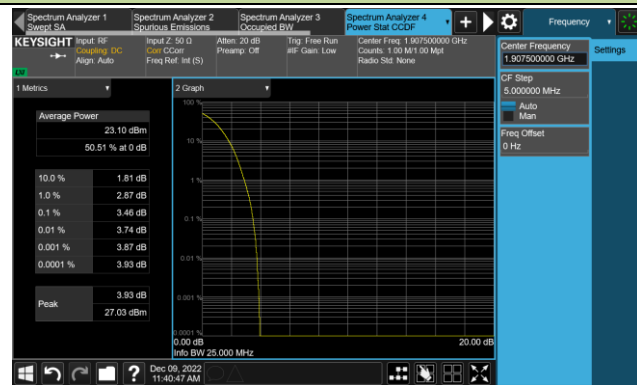

WCDMA Band IV

Channel 1312 (1712.4MHz)

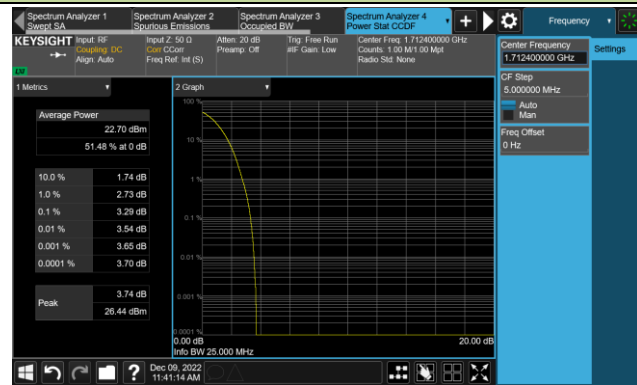

Channel 1412 (1732.4MHz)

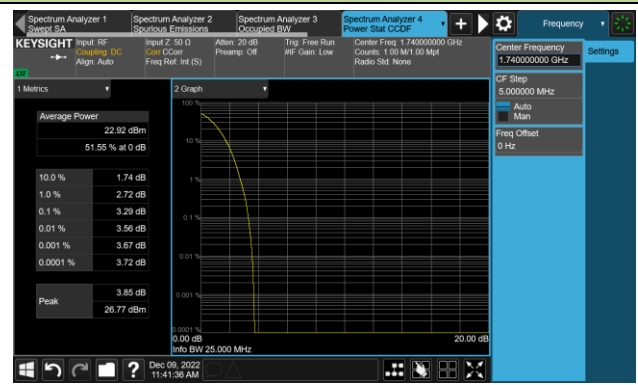

Channel 1513 (1752.6MHz)

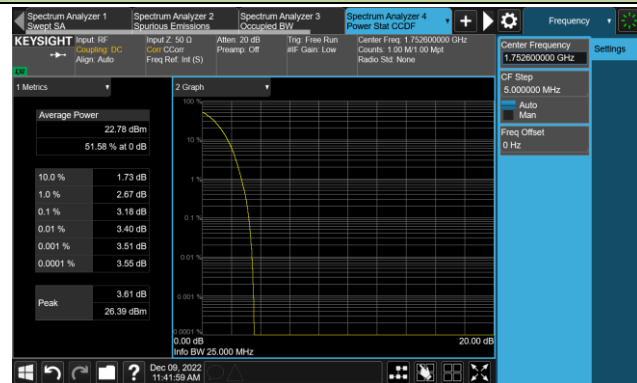

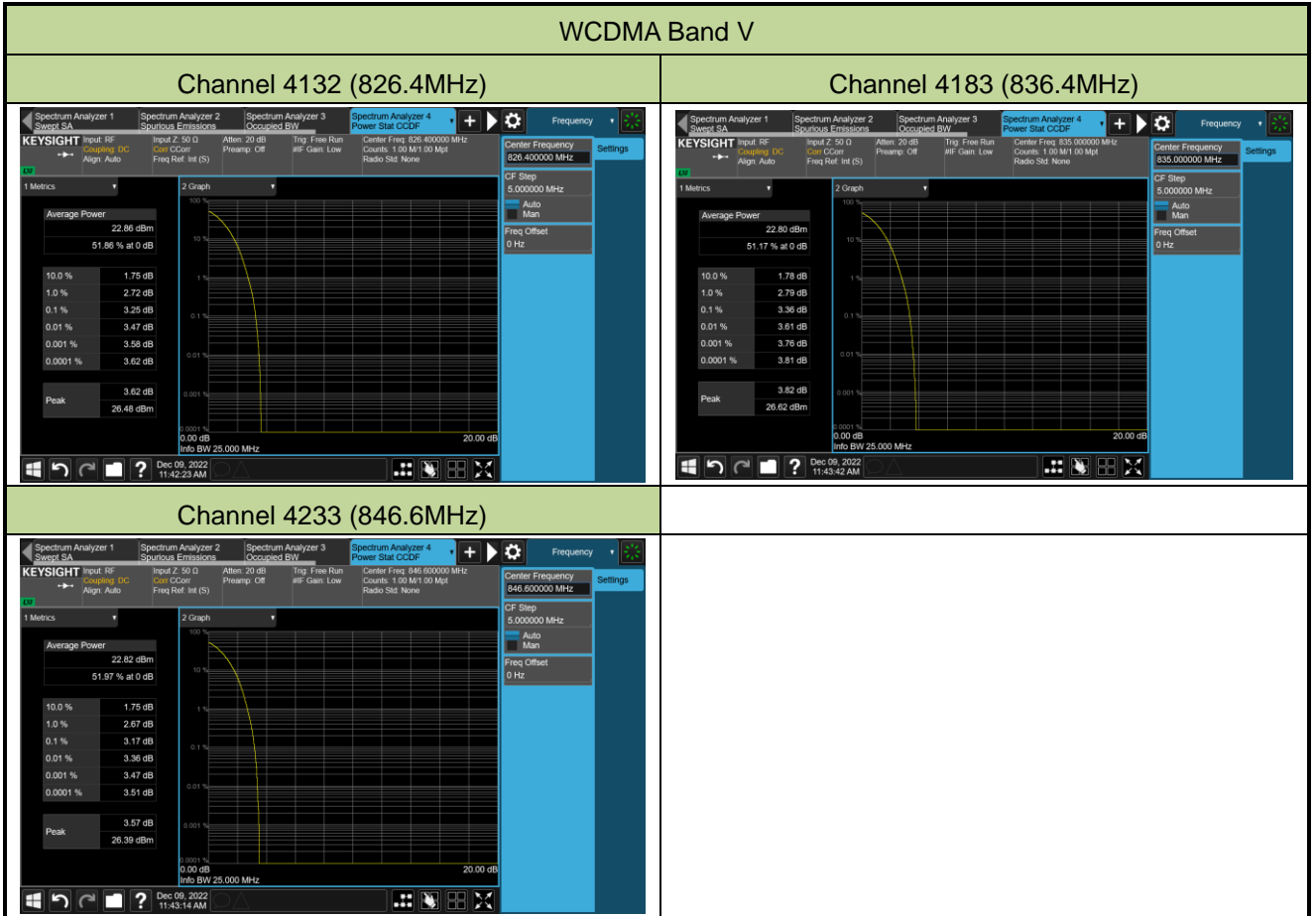

A.6 Conducted Spurious Emissions Test Result

Test Site	SIP-SR1	Test Engineer	Candy Luo
Test Date	2022/12/07	Test Band	GSM 850, PCS 1900

Mode	Frequency (MHz)	Frequency Range (MHz)	Max Spurious Emissions (dBm)	Limit (dBm)	Result
GSM 850 GPRS	824.2	30 ~ 10000	-42.37	≤ -13.00	Pass
	836.4	30 ~ 10000	-42.03	≤ -13.00	Pass
	848.8	30 ~ 10000	-41.99	≤ -13.00	Pass
PCS 1900 GPRS	1850.2	30 ~ 20000	-36.80	≤ -13.00	Pass
	1880.0	30 ~ 20000	-36.74	≤ -13.00	Pass
	1909.8	30 ~ 20000	-36.78	≤ -13.00	Pass

GSM 850_GPRS

Low Channel

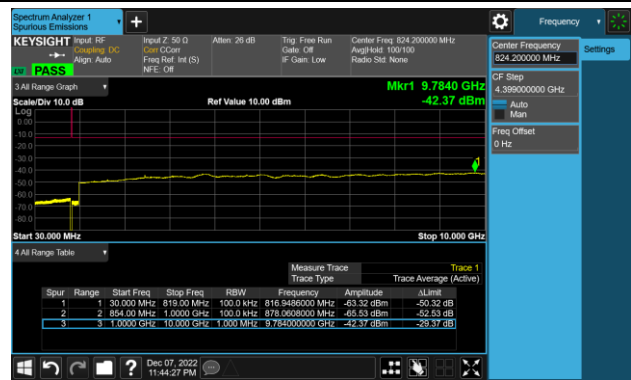

Middle Channel

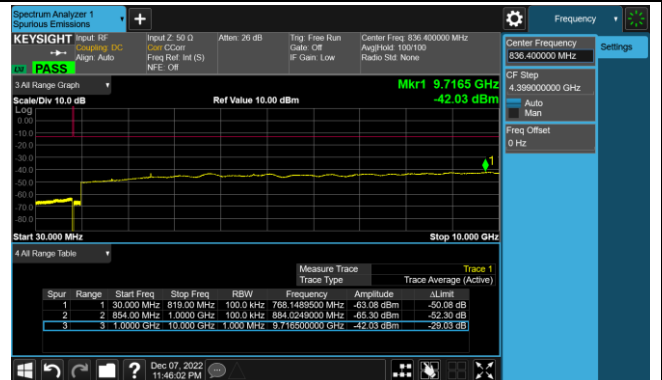

High Channel

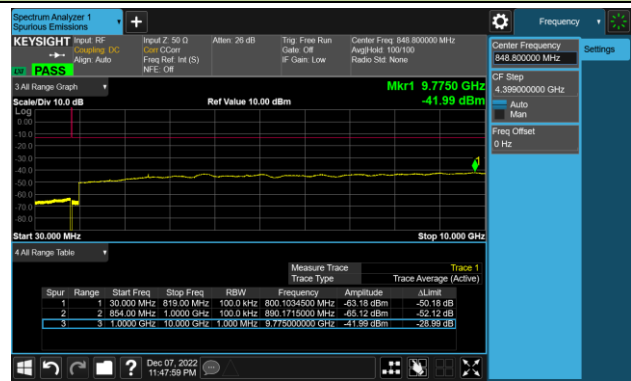

PCS 1900_GPRS

Low Channel

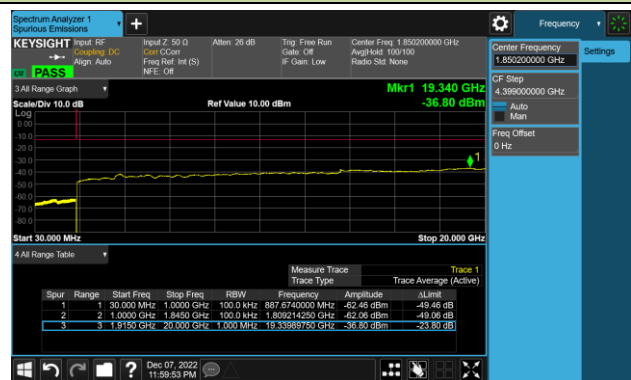

Middle Channel

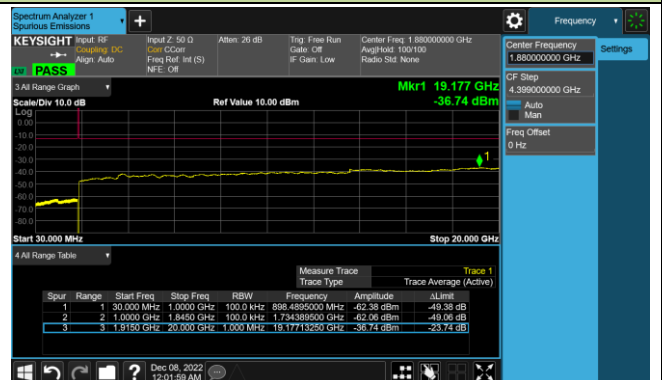

High Channel

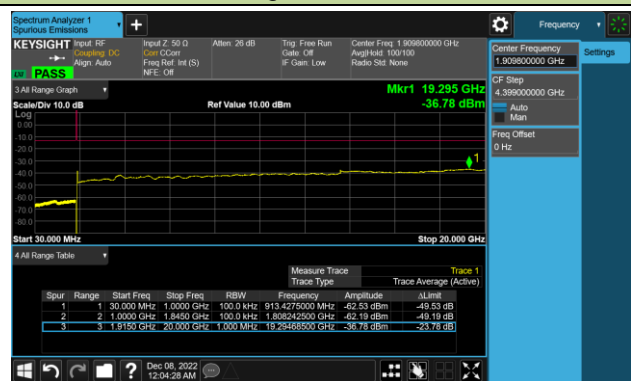

Test Site	WZ-SR6	Test Engineer	Cloud Guo
Test Date	2022/12/09	Test Band	WCDMA Band II, IV, V

Mode	Frequency (MHz)	Frequency Range (MHz)	Max Spurious Emissions (dBm)	Limit (dBm)	Result
WCDMA Band II	1852.4	30 ~ 20000	-40.88	≤ -13.00	Pass
	1880.0	30 ~ 20000	-41.49	≤ -13.00	Pass
	1907.6	30 ~ 20000	-40.98	≤ -13.00	Pass
WCDMA Band IV	1712.4	30 ~ 20000	-40.92	≤ -13.00	Pass
	1732.4	30 ~ 20000	-40.18	≤ -13.00	Pass
	1752.6	30 ~ 20000	-41.92	≤ -13.00	Pass
WCDMA Band V	826.4	30 ~ 10000	-41.87	≤ -13.00	Pass
	836.4	30 ~ 10000	-42.02	≤ -13.00	Pass
	846.6	30 ~ 10000	-42.43	≤ -13.00	Pass

WCDMA Band II

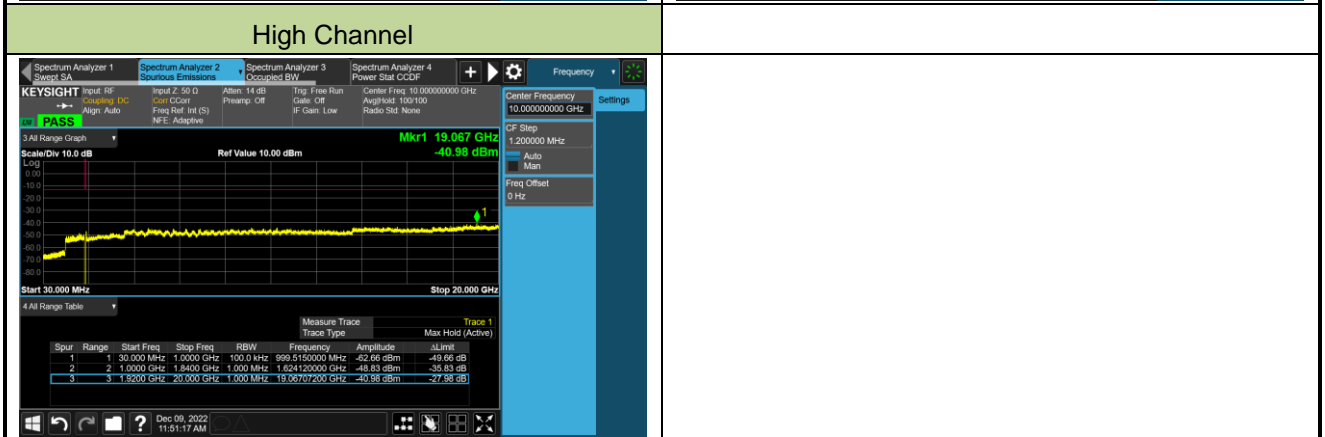
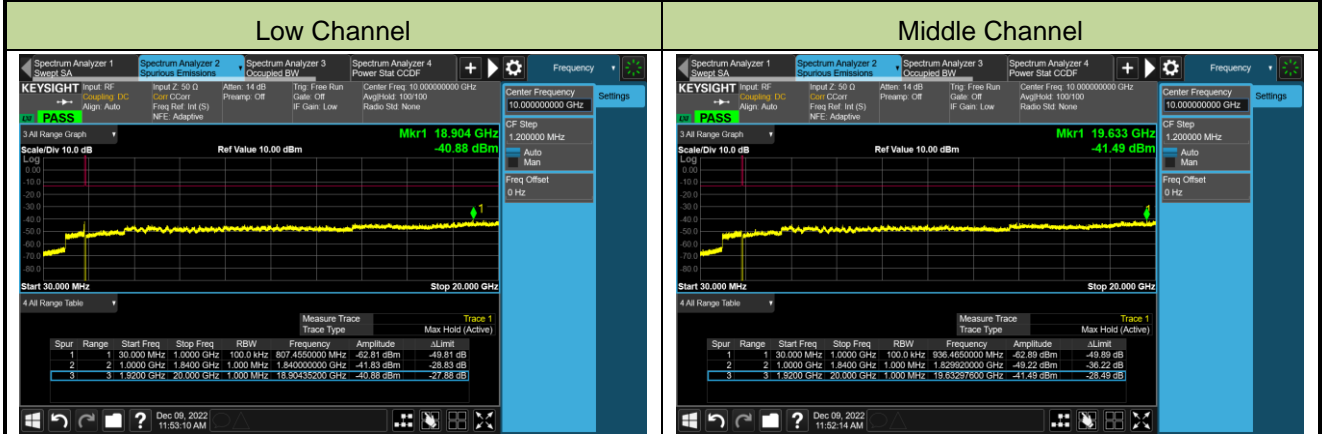

WCDMA Band IV

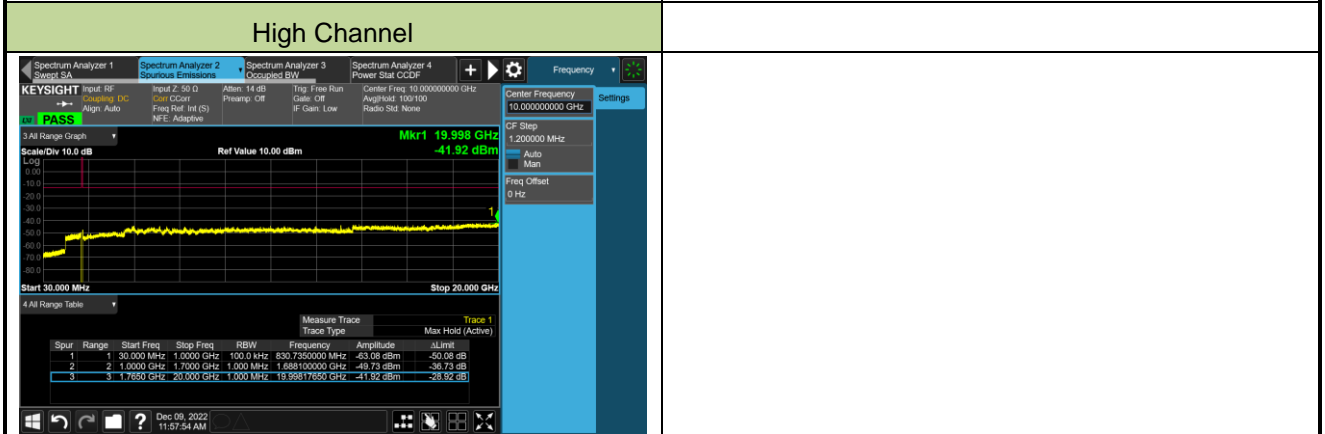
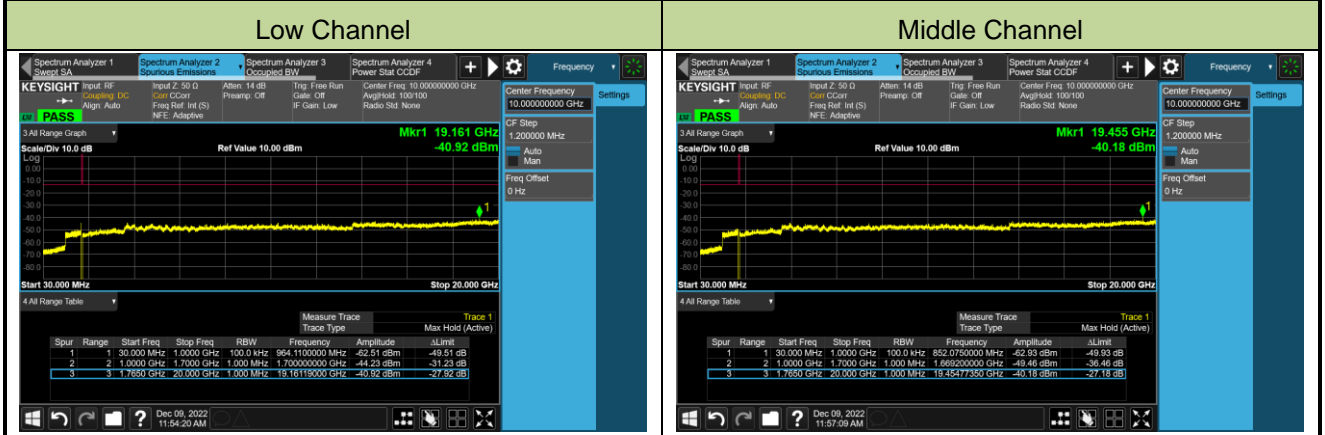

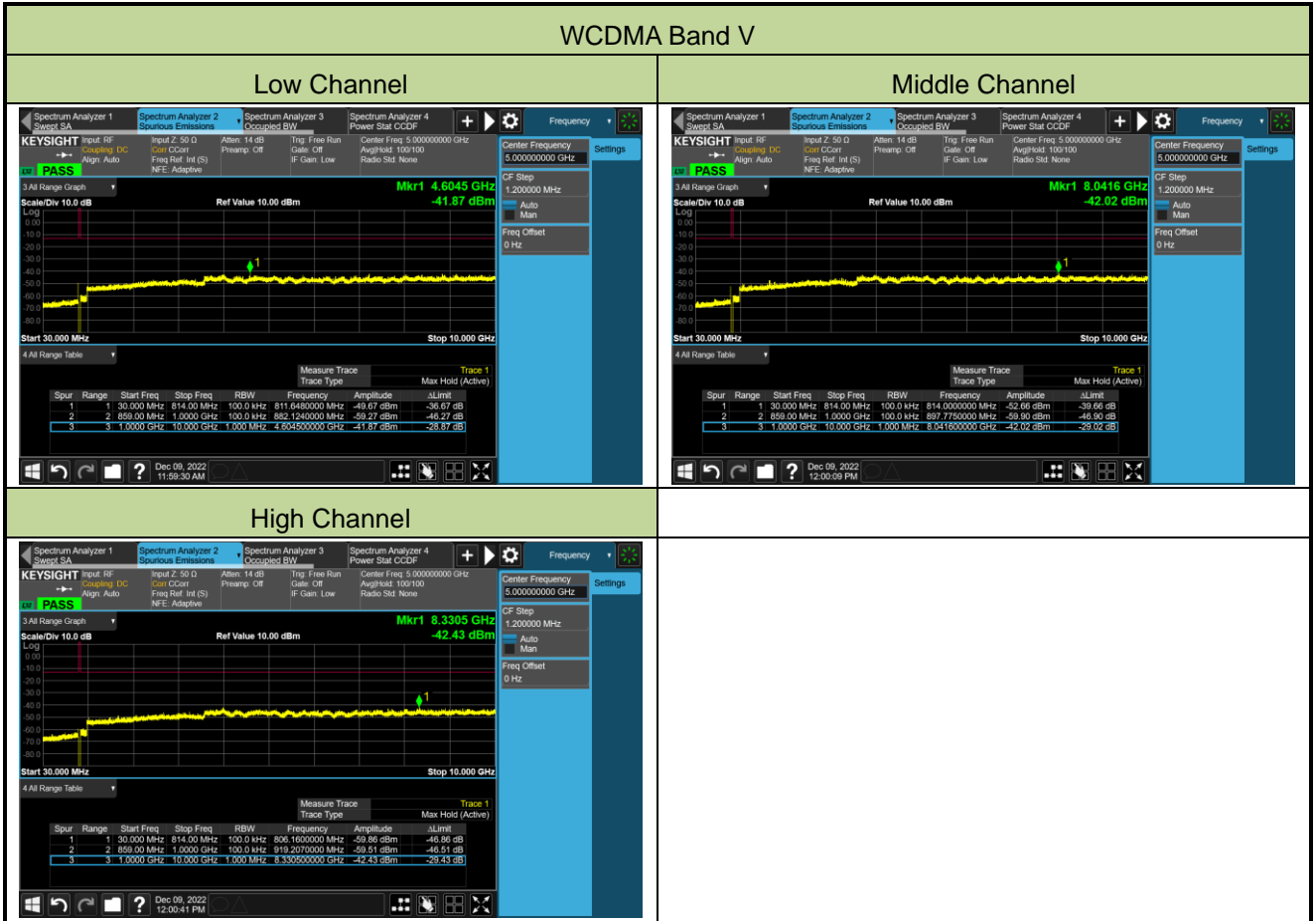

A.7 Radiated Spurious Emissions Test Result

Test Site	SIP-AC1	Test Engineer	Wayne Wang
Test Date	2022/12/03 ~ 2022/12/05	Test Band	GSM 850_GPRS

Frequency (MHz)	Reading Level (dBμV)	Factor (dB/m)	Measure Level (dBμV/m)	Limit (dBμV/m)	Margin (dB)	Detector	Polarization
Low Channel							
153.2	19.5	18.3	37.8	82.3	-44.5	Peak	Horizontal
649.8	21.0	26.4	47.4	82.3	-34.9	Peak	Horizontal
152.2	19.0	18.3	37.3	82.3	-45.0	Peak	Vertical
666.8	20.6	26.6	47.2	82.3	-35.1	Peak	Vertical
3686.0	50.9	-11.8	39.1	82.3	-43.2	Peak	Horizontal
16130.0	42.9	3.8	46.7	82.3	-35.6	Peak	Horizontal
3295.0	53.3	-13.4	39.9	82.3	-42.4	Peak	Vertical
7723.5	48.1	-6.4	41.7	82.3	-40.6	Peak	Vertical
Middle Channel							
150.3	21.7	18.2	39.9	82.3	-42.4	Peak	Horizontal
659.5	21.7	26.6	48.3	82.3	-34.0	Peak	Horizontal
152.2	20.5	18.3	38.8	82.3	-43.5	Peak	Vertical
645.5	20.8	26.3	47.1	82.3	-35.2	Peak	Vertical
7128.5	47.8	-6.9	40.9	82.3	-41.4	Peak	Horizontal
14608.5	45.3	0.4	45.7	82.3	-36.6	Peak	Horizontal
7689.5	47.9	-6.3	41.6	82.3	-40.7	Peak	Vertical
14821.0	44.3	1.1	45.4	82.3	-36.9	Peak	Vertical
High Channel							
157.6	19.9	18.1	38.0	82.3	-44.3	Peak	Horizontal
435.9	20.8	22.1	42.9	82.3	-39.4	Peak	Horizontal
149.3	20.3	18.2	38.5	82.3	-43.8	Peak	Vertical
573.7	20.5	24.5	45.0	82.3	-37.3	Peak	Horizontal
4425.5	50.0	-10.4	39.6	82.3	-42.7	Peak	Horizontal
9959.0	46.7	-4.7	42.0	82.3	-40.3	Peak	Vertical
3397.0	52.9	-12.9	40.0	82.3	-42.3	Peak	Vertical
7698.0	47.5	-6.3	41.2	82.3	-41.1	Peak	Horizontal

Note: Measure Level (dBμV/m) = Reading Level (dBμV) + Factor (dB/m).

Test Site	SIP-AC3	Test Engineer	Wayne Wang
Test Date	2022/12/03 ~ 2022/12/05	Test Band	PCS 1900_GPRS

Frequency (MHz)	Reading Level (dBμV)	Factor (dB/m)	Measure Level (dBμV/m)	Limit (dBμV/m)	Margin (dB)	Detector	Polarization
Low Channel							
152.7	13.4	18.3	31.7	82.3	-50.6	Peak	Horizontal
614.4	2.6	25.7	28.3	82.3	-54.0	Peak	Horizontal
147.9	11.1	18.2	29.3	82.3	-53.0	Peak	Vertical
614.4	6.2	25.7	31.9	82.3	-50.4	Peak	Vertical
3703.0	56.1	-12.4	43.7	82.3	-38.6	Peak	Horizontal
17277.5	43.6	5.2	48.8	82.3	-33.5	Peak	Horizontal
3703.0	61.9	-12.4	49.5	82.3	-32.8	Peak	Vertical
11098.0	57.4	-4.4	53.0	82.3	-29.3	Peak	Vertical
Middle Channel							
152.7	12.1	18.3	30.4	82.3	-51.9	Peak	Horizontal
691.1	3.8	26.6	30.4	82.3	-51.9	Peak	Horizontal
150.8	13.3	18.3	31.6	82.3	-50.7	Peak	Vertical
614.4	11.0	25.7	36.7	82.3	-45.6	Peak	Vertical
5802.5	50.7	-9.4	41.3	82.3	-41.0	Peak	Horizontal
17549.5	44.3	5.8	50.1	82.3	-32.2	Peak	Horizontal
3762.5	55.9	-11.7	44.2	82.3	-38.1	Peak	Vertical
5641.0	52.4	-9.5	42.9	82.3	-39.4	Peak	Vertical
High Channel							
151.7	12.6	18.3	30.9	82.3	-51.4	Peak	Horizontal
614.4	9.1	25.7	34.8	82.3	-47.5	Peak	Horizontal
68.3	16.5	16.1	32.6	82.3	-49.7	Peak	Vertical
150.8	12.3	18.3	30.6	82.3	-51.7	Peak	Vertical
7808.5	48.6	-6.5	42.1	82.3	-40.2	Peak	Horizontal
18000.0	42.0	7.2	49.2	82.3	-33.1	Peak	Horizontal
3822.0	53.7	-11.5	42.2	82.3	-40.1	Peak	Vertical
5726.0	54.6	-9.7	44.9	82.3	-37.4	Peak	Vertical

Note: Measure Level (dBμV/m) = Reading Level (dBμV) + Factor (dB/m).

Test Site	SIP-AC3	Test Engineer	Wayne Wang
Test Date	2022/12/03 ~ 2022/12/05	Test Band	WCDMA Band II

Frequency (MHz)	Reading Level (dBμV)	Factor (dB/m)	Measure Level (dBμV/m)	Limit (dBμV/m)	Margin (dB)	Detector	Polarization
Low Channel							
153.7	14.2	18.2	32.4	82.3	-49.9	Peak	Horizontal
474.3	4.9	22.5	27.4	82.3	-54.9	Peak	Horizontal
63.5	14.1	17.0	31.1	82.3	-51.2	Peak	Vertical
153.2	11.6	18.3	29.9	82.3	-52.4	Peak	Vertical
3703.0	54.5	-12.4	42.1	82.3	-40.2	Peak	Horizontal
8106.0	48.2	-6.0	42.2	82.3	-40.1	Peak	Horizontal
3703.0	55.0	-12.4	42.6	82.3	-39.7	Peak	Vertical
5556.0	55.1	-9.3	45.8	82.3	-36.5	Peak	Vertical
Middle Channel							
151.3	14.4	18.3	32.7	82.3	-49.6	Peak	Horizontal
228.9	11.9	15.1	27.0	82.3	-55.3	Peak	Horizontal
150.3	10.9	18.2	29.1	82.3	-53.2	Peak	Vertical
487.8	13.1	22.9	36.0	82.3	-46.3	Peak	Vertical
3762.5	54.0	-11.7	42.3	82.3	-40.0	Peak	Horizontal
8386.5	48.7	-5.8	42.9	82.3	-39.4	Peak	Horizontal
3762.5	55.7	-11.7	44.0	82.3	-38.3	Peak	Vertical
5641.0	56.1	-9.5	46.6	82.3	-35.7	Peak	Vertical
High Channel							
150.3	14.8	18.2	33.0	82.3	-49.3	Peak	Horizontal
469.4	6.0	22.4	28.4	82.3	-53.9	Peak	Horizontal
63.5	14.9	17.0	31.9	82.3	-50.4	Peak	Vertical
150.3	11.7	18.2	29.9	82.3	-52.4	Peak	Vertical
3813.5	54.7	-11.5	43.2	82.3	-39.1	Peak	Horizontal
8233.5	48.9	-5.7	43.2	82.3	-39.1	Peak	Horizontal
3813.5	57.8	-11.5	46.3	82.3	-36.0	Peak	Vertical
5726.0	56.7	-9.7	47.0	82.3	-35.3	Peak	Vertical

Note: Measure Level (dBμV/m) = Reading Level (dBμV) + Factor (dB/m).

Test Site	SIP-AC3	Test Engineer	Wayne Wang
Test Date	2022/12/03 ~ 2022/12/05	Test Band	WCDMA Band IV

Frequency (MHz)	Reading Level (dBμV)	Factor (dB/m)	Measure Level (dBμV/m)	Limit (dBμV/m)	Margin (dB)	Detector	Polarization
Low Channel							
152.2	15.2	18.3	33.5	82.3	-48.8	Peak	Horizontal
525.2	5.2	23.6	28.8	82.3	-53.5	Peak	Horizontal
58.1	13.9	17.5	31.4	82.3	-50.9	Peak	Vertical
150.3	10.7	18.2	28.9	82.3	-53.4	Peak	Vertical
4332.0	51.6	-10.2	41.4	82.3	-40.9	Peak	Horizontal
7970.0	48.6	-5.9	42.7	82.3	-39.6	Peak	Horizontal
5139.5	54.9	-10.1	44.8	82.3	-37.5	Peak	Vertical
6848.0	52.2	-7.4	44.8	82.3	-37.5	Peak	Vertical
Middle Channel							
152.2	14.9	18.3	33.2	82.3	-49.1	Peak	Horizontal
468.4	5.0	22.5	27.5	82.3	-54.8	Peak	Horizontal
57.6	13.7	17.6	31.3	82.3	-51.0	Peak	Vertical
152.2	10.9	18.3	29.2	82.3	-53.1	Peak	Vertical
5641.0	49.9	-9.5	40.4	82.3	-41.9	Peak	Horizontal
9593.5	48.0	-5.1	42.9	82.3	-39.4	Peak	Horizontal
3482.0	55.4	-12.4	43.0	82.3	-39.3	Peak	Vertical
6967.0	51.3	-7.1	44.2	82.3	-38.1	Peak	Vertical
High Channel							
289.5	7.8	18.2	26.0	82.3	-56.3	Peak	Horizontal
512.1	5.4	23.3	28.7	82.3	-53.6	Peak	Horizontal
57.6	13.4	17.6	31.0	82.3	-51.3	Peak	Vertical
298.7	16.7	18.4	35.1	82.3	-47.2	Peak	Vertical
5258.5	51.2	-9.7	41.5	82.3	-40.8	Peak	Horizontal
9177.0	47.8	-5.4	42.4	82.3	-39.9	Peak	Horizontal
3507.5	56.1	-12.6	43.5	82.3	-38.8	Peak	Vertical
5258.5	54.6	-9.7	44.9	82.3	-37.4	Peak	Vertical

Note: Measure Level (dBμV/m) = Reading Level (dBμV) + Factor (dB/m).

Test Site	SIP-AC3	Test Engineer	Wayne Wang
Test Date	2022/12/03 ~ 2022/12/05	Test Band	WCDMA Band V

Frequency (MHz)	Reading Level (dBμV)	Factor (dB/m)	Measure Level (dBμV/m)	Limit (dBμV/m)	Margin (dB)	Detector	Polarization
Low Channel							
263.3	28.3	16.9	45.2	82.3	-37.1	Peak	Horizontal
872.9	21.0	28.5	49.5	82.3	-32.8	Peak	Horizontal
151.7	14.6	18.3	32.9	82.3	-49.4	Peak	Vertical
873.4	20.5	28.5	49.0	82.3	-33.3	Peak	Vertical
2480.0	58.9	-16.3	42.6	82.3	-39.7	Peak	Horizontal
4432.0	51.1	-10.3	40.8	82.3	-41.5	Peak	Horizontal
1652.0	56.9	-19.7	37.2	82.3	-45.1	Peak	Vertical
2484.0	63.1	-16.4	46.7	82.3	-35.6	Peak	Vertical
Middle Channel							
149.3	16.7	18.2	34.9	82.3	-47.4	Peak	Horizontal
878.8	20.6	28.6	49.2	82.3	-33.1	Peak	Horizontal
233.2	21.1	15.5	36.6	82.3	-45.7	Peak	Vertical
878.8	20.7	28.6	49.3	82.3	-33.0	Peak	Vertical
2504.0	56.8	-16.3	40.5	82.3	-41.8	Peak	Horizontal
3032.0	57.4	-14.2	43.2	82.3	-39.1	Peak	Horizontal
2500.0	62.2	-16.4	45.8	82.3	-36.5	Peak	Vertical
4932.0	50.3	-9.7	40.6	82.3	-41.7	Peak	Vertical
High Channel							
149.3	17.0	18.2	35.2	82.3	-47.1	Peak	Horizontal
307.9	23.9	18.7	42.6	82.3	-39.7	Peak	Horizontal
144.5	14.7	18.0	32.7	82.3	-49.6	Peak	Vertical
890.4	21.2	28.8	50.0	82.3	-32.3	Peak	Vertical
1696.0	59.8	-20.0	39.8	82.3	-42.5	Peak	Horizontal
2432.0	60.9	-16.6	44.3	82.3	-38.0	Peak	Horizontal
1696.0	59.9	-20.0	39.9	82.3	-42.4	Peak	Vertical
2544.0	75.3	-15.8	59.5	82.3	-22.8	Peak	Vertical

Note: Measure Level (dBμV/m) = Reading Level (dBμV) + Factor (dB/m).

Appendix B - Test Setup Photograph

Refer to "2211RSU065-UT" file.

Appendix C - EUT Photograph

Refer to "2211RSU065-UE" file.