

MEASUREMENT REPORT

FCC PART 2 & 22 & 24 & 27 & 90

FCC ID: XMR2021SC20AD

Application: Quectel Wireless Solutions Co., Ltd

Application Type: Certification

Product: LTE Module

Model No.: SC20-AD

Brand Name: Quectel

FCC Rule Part(s): Part 2, Part 22 (H), 24 (E), 27, 90

Test Procedure(s): ANSI C63.26: 2015

Test Date: December 14 ~ 23, 2021

Reviewed By:

Sunny Sun

Approved By:

Robin Wu



The test results relate only to the samples tested.

This equipment has been shown to be capable of compliance with the applicable technical standards as indicated in the measurement report and was tested in accordance with the measurement procedures specified in ANSI C63.26-2015. Test results reported herein relate only to the item(s) tested.

The test report shall not be reproduced except in full without the written approval of MRT Technology (Suzhou) Co., Ltd.

Revision History

Report No.	Version	Description	Issue Date	Note
2112RSU024-U5	Rev. 01	Initial Report	01-13-2022	Valid

Note: For the difference between FCC IDs “XMR2021SC20AD” and “XMR201706SC20A”, “XMR2021SC20AD” disabled WCDMA, GSM and voice part via software and removed some small RF components which are used in WCDMA and GSM. This report is based on “XMR201706SC20A” original report to supplement the spot check related test items with worst mode.

CONTENTS

Description	Page
1. GENERAL INFORMATION	4
1.1. Applicant	4
1.2. Manufacturer	4
1.3. Testing Facility	4
1.4. Product Information	5
1.5. Radio Specification	5
1.6. Description of Available Antennas	6
1.7. Applied Standard	6
1.8. Device Capabilities	6
2. TEST CONFIGURATION	7
2.1. Configuration of Tested System	7
2.2. Test Environment Condition	7
3. TEST EQUIPMENT CALIBRATION DATE	8
4. MEASUREMENT UNCERTAINTY	9
5. TEST RESULT	10
5.1. Summary	10
5.2. Equivalent Isotropically Radiated Power Measurement	11
5.2.1. Test Limit	11
5.2.2. Test Procedure	11
5.2.3. Test Setting	11
5.2.4. Test Setup	12
5.2.5. Test Result	13
5.3. Radiated Spurious Emission Measurement	29
5.3.1. Test Limit	29
5.3.2. Test Procedure	29
5.3.3. Test Setting	29
5.3.4. Test Setup	30
5.3.5. Test Result	31
Appendix A - Test Setup Photograph	38
Appendix B - EUT Photograph	39

1.4. Product Information

Product Name	LTE Module
Model No.	SC20-AD
Serial No.	D1Y21L22E000063
Brand Name	Quectel
Operating Temperature	-35 ~ 75°C
Wi-Fi Specification	802.11a/b/g/n
Bluetooth Specification	V4.1 dual mode
E-UTRA Band	Band 2, 4, 5, 7, 12, 13, 25, 26
Note: The information of EUT was provided by the manufacturer, and the accuracy of the information shall be the responsibility of the manufacturer.	

1.5. Radio Specification

T _x Frequency Range	Band 2: 1850 ~ 1910 MHz; Band 4: 1710 ~ 1755 MHz Band 5: 824 ~ 849 MHz; Band 7: 2500 ~ 2570 MHz Band 12: 699 ~ 716 MHz; Band 13: 777 ~ 787 MHz Band 25: 1850 ~ 1915 MHz; Band 26: 814 ~ 849 MHz
R _x Frequency Range	Band 2: 1930 ~ 1990 MHz; Band 4: 2110 ~ 2155 MHz Band 5: 869 ~ 894 MHz; Band 7: 2620 ~ 2690 MHz Band 12: 729 ~ 746 MHz; Band 13: 746 ~ 756 MHz Band 25: 1930 ~ 1995 MHz; Band 26: 859 ~ 894 MHz
Modulation	QPSK, 16QAM

Note: For other features of this EUT, test report will be issued separately.

1.6. Description of Available Antennas

Technology	Frequency Range (MHz)	Antenna Type	Max Peak Gain (dBi)
LTE Band 2	1850 ~ 1910	PIFA	2.00
LTE Band 4	1710 ~ 1755		2.00
LTE Band 5	824 ~ 849		2.00
LTE Band 7	2500 ~ 2570		3.00
LTE Band 12	699 ~ 716		3.00
LTE Band 13	777 ~ 787		4.00
LTE Band 25	1850 ~ 1915		2.00
LTE Band 26	814 ~ 849		2.00
Remark: 1. All antenna information (Antenna type and Peak Gain) is provided by the manufacturer. 2. This typical antenna is only used to calculate the ERP or EIRP.			

1.7. Applied Standard

According to the specifications of the manufacturer, the EUT must comply with the requirements of the following standards:

- ANSI C63.26:2015
- FCC CFR 47 Part 2, Part 22, Part 24, Part 27, Part 90
- FCC KDB 971168 D01 v03r01: Power Meas License Digital Systems
- FCC KDB 971168 D02 v02r01: Misc Rev Approv License Devices
- FCC KDB 412172 D01 v01r01: Determining ERP and EIRP

1.8. Device Capabilities

This device contains the following capabilities:

Working on LTE Band 2, 4, 5, 7, 12, 13, 25, 26

LTE Band 25 (1850 ~ 1915 MHz) overlaps the entire frequency range of LTE Band 2 (1850 ~ 1910 MHz). Therefore, test data provided in this report covers Band 2 as well as Band 25.

LTE Band 26 (814 ~ 849 MHz) overlaps the entire frequency range of LTE Band 5 (824 ~ 849 MHz). Therefore, test data provided in this report covers Band 5 as well as Band 26.

2. TEST CONFIGURATION

2.1. Configuration of Tested System

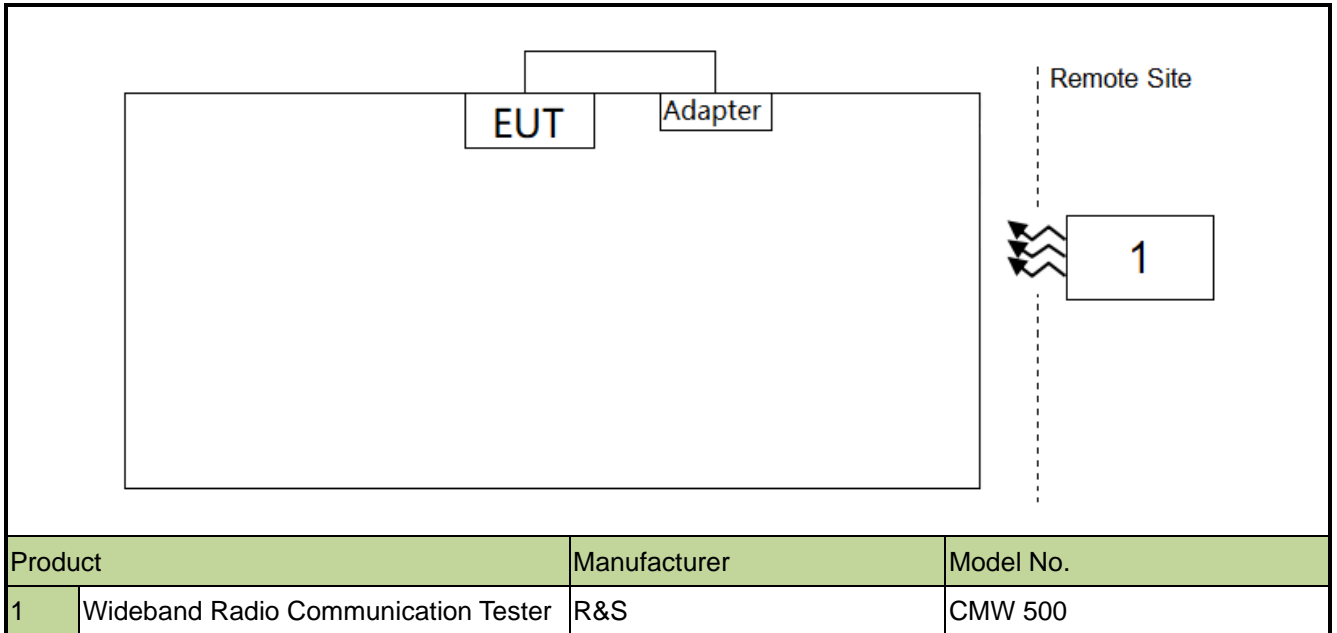

2.2. Test Environment Condition

Ambient Temperature	15 ~ 35°C
Relative Humidity	20% ~ 75%RH

3. TEST EQUIPMENT CALIBRATION DATE

Instrument Name	Manufacturer	Model No.	Asset No.	Cali. Interval	Cal. Due Date	Test Site
EMI Test Receiver	R&S	ESR7	MRTSUE06001	1 year	2022/1/4	WZ-AC1
Horn Antenna	Schwarzbeck	BBHA 9120D	MRTSUE06023	1 year	2022/9/16	WZ-AC1
Radio Communication Analyzer	Anritsu	MT8821C	MRTSUE06960	1 year	2022/7/1	WZ-SR6
Radio Communication Test Station	Anritsu	MT8000A	MRTSUE06961	1 year	2022/7/1	WZ-SR6
5G Wireless Test Platform	Keysight	E7515B	MRTSUE06942	1 year	2022/3/29	WZ-SR6
Preamplifier	Agilent	83017A	MRTSUE06076	1 year	2022/11/12	WZ-AC1
TRILOG Antenna	Schwarzbeck	VULB 9168	MRTSUE06172	1 year	2022/8/5	WZ-AC1
Thermohygrometer	Yuhuaze	HTC-2	MRTSUE06184	1 year	2022/8/10	WZ-AC1
Anechoic Chamber	TDK	WZ-AC1	MRTSUE06212	1 year	2022/4/29	WZ-AC1
Thermohygrometer	testo	608-H1	MRTSUE06403	1 year	2022/6/28	WZ-AC1
Signal Analyzer	Keysight	N9010B	MRTSUE06607	1 year	2022/1/6	WZ-AC1

Software	Version	Function
EMI Software	V3	EMI Test Software

4. MEASUREMENT UNCERTAINTY

Where relevant, the following test uncertainty levels have been estimated for tests performed on the EUT as specified in CISPR 16-4-2. This uncertainty represents an expanded uncertainty expressed at approximately the 95% confidence level using a coverage factor of $k = 2$.

Radiated Spurious Emissions
Measurement Uncertainty for a Level of Confidence of 95% ($U=2Uc(y)$): Horizontal: 9kHz ~ 300MHz: 5.04dB 300MHz ~ 1GHz: 4.95dB 1GHz ~ 40GHz: 6.40dB Vertical: 9kHz ~ 300MHz: 5.24dB 300MHz ~ 1GHz: 6.03dB 1GHz ~ 40GHz: 6.40dB
Output Power
Measuring Uncertainty for a Level of Confidence of 95% ($U=2Uc(y)$): 1.13dB

5. TEST RESULT

5.1. Summary

FCC Part Section(s)	Test Description	Test Condition	Test Result	Reference
22.913(a)(5), 27.50(b)(9) 27.50(c)(9), 24.232(c) 27.50(h)(2), 27.50(d)(4) 90.635	Equivalent Radiated Power	Conducted	Pass	Section 5.2
2.1053, 22.917(a) 24.238(a), 27.53(c), (g), (h), (m), 90.691(a)	Spurious Emission	Radiated	Pass	Section 5.3

Notes:

- 1) The analyzer plots shown in this section were all taken with a correction table loaded into the analyzer. The correction table was used to account for the losses of the cables and attenuators used as part of the system to connect the EUT to the analyzer at all frequencies of interest.
- 2) All supported modulation types were evaluated. The worst-case emission of modulation was selected. Therefore, Radiated Spurious Emission were presented the worst-case in the test report.

5.2. Equivalent Isotropically Radiated Power Measurement

5.2.1. Test Limit

Band 5/26 (824 ~ 849) :

The ERP of mobile transmitters and auxiliary test transmitters must not exceed 7 watts.

Band 12, 13

Control stations and mobile stations transmitting in the 746-757 MHz, 776-788 MHz, and 805-806 MHz bands are limited to 30 watts ERP.

Control and mobile stations in the 698-746 MHz band are limited to 30 watts ERP.

Band 2/25,7:

Mobile and portable stations are limited to 2 watts EIRP and the equipment must employ a means for limiting power to the minimum necessary for successful communications.

Band 4:

Fixed, mobile stations operating in the 1710-1755 MHz band and mobile in the 1695-1710 MHz and 1755-1780 MHz bands are limited to 1 watt EIRP.

Band 5/26 (824 ~ 849) :

The maximum output power of the transmitter for mobile stations is 100 watts (20dBw).

5.2.2. Test Procedure

ANSI C63.26-2015 - Section 5.2

5.2.3. Test Setting

Average power measurements were performed only when the EUT was transmitting at its maximum power control level using a broadband power meter with a pulse sensor. The power meter implemented triggering and gating capabilities which were set up such that power measurements were recorded only during the ON time of the transmitter.

The relevant equation for determining the maximum ERP or EIRP from the measured RF output power is given in Equation (1) as follows:

$$\text{ERP or EIRP} = P_{\text{Meas}} + G_T$$

where

ERP or EIRP effective radiated power or equivalent isotropically radiated power, respectively (expressed in the same units as P_{Meas} , e.g., dBm or dBW)

P_{Meas} measured transmitter output power or PSD, in dBm or dBW

G_T gain of the transmitting antenna, in dBd (ERP) or dBi (EIRP)

$$\text{ERP} = \text{EIRP} - 2.15$$

5.2.4. Test Setup

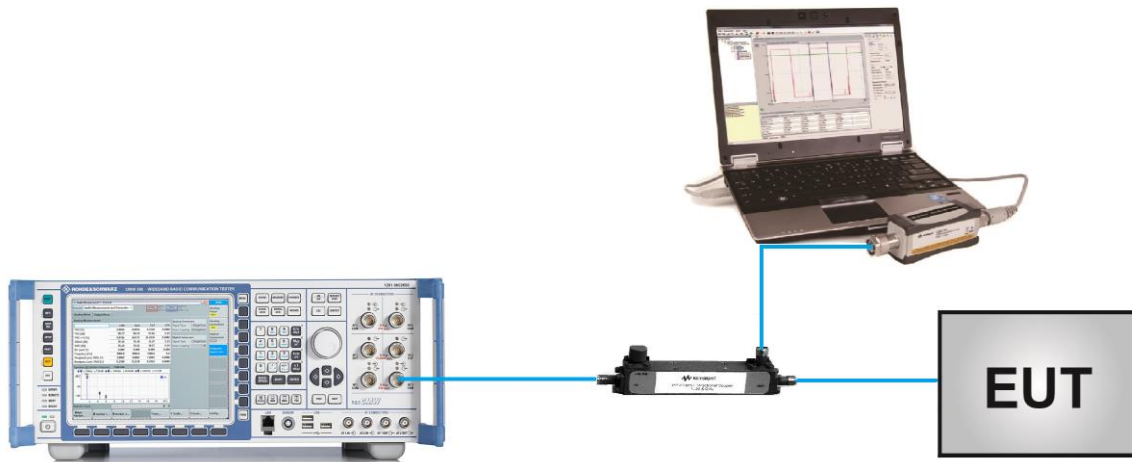

5.2.5. Test Result

Product	LTE Module	Test Site	WZ-SR6
Test Engineer	Eric Xu	Test Date	2021/12/14 ~ 2021/12/23
Test Band	LTE Band 2/25		

Channel No.	Frequency (MHz)	Channel Bandwidth (MHz)	RB Size	RB Offset	Output Power (dBm)	EIRP (dBm)	Limit (dBm)
QPSK							
26047	1850.70	1.4	1	0	22.38	24.38	< 33.01
26365	1882.50				22.49	24.49	< 33.01
26683	1914.30				22.37	24.37	< 33.01
26047	1850.70	1.4	1	2	22.47	24.47	< 33.01
26365	1882.50				22.51	24.51	< 33.01
26683	1914.30				22.45	24.45	< 33.01
26047	1850.70	1.4	1	6	22.15	24.15	< 33.01
26365	1882.50				22.61	24.61	< 33.01
26683	1914.30				22.42	24.42	< 33.01
26047	1850.70	1.4	6	0	21.46	23.46	< 33.01
26365	1882.50				21.52	23.52	< 33.01
26683	1914.30				21.46	23.46	< 33.01
26055	1851.50	3	1	0	22.64	24.64	< 33.01
26365	1882.50				22.36	24.36	< 33.01
26675	1913.50				22.49	24.49	< 33.01
26055	1851.50	3	1	7	22.50	24.50	< 33.01
26365	1882.50				22.64	24.64	< 33.01
26675	1913.50				22.25	24.25	< 33.01
26055	1851.50	3	1	14	22.57	24.57	< 33.01
26365	1882.50				22.82	24.82	< 33.01
26675	1913.50				22.36	24.36	< 33.01
26055	1851.50	3	15	0	21.55	23.55	< 33.01
26365	1882.50				21.63	23.63	< 33.01
26675	1913.50				21.52	23.52	< 33.01

Note: The EIRP (dBm) = Output Power (dBm) + Antenna Gain (dBi)

Channel No.	Frequency (MHz)	Channel Bandwidth (MHz)	RB Size	RB Offset	Output Power (dBm)	EIRP (dBm)	Limit (dBm)
QPSK							
26065	1852.50	5	1	0	22.33	24.33	< 33.01
26365	1882.50				22.50	24.50	< 33.01
26665	1912.50				22.41	24.41	< 33.01
26065	1852.50	5	1	12	22.33	24.33	< 33.01
26365	1882.50				22.40	24.40	< 33.01
26665	1912.50				22.22	24.22	< 33.01
26065	1852.50	5	1	24	22.49	24.49	< 33.01
26365	1882.50				22.21	24.21	< 33.01
26665	1912.50				22.37	24.37	< 33.01
26065	1852.50	5	25	0	21.53	23.53	< 33.01
26365	1882.50				21.58	23.58	< 33.01
26665	1912.50				21.58	23.58	< 33.01
26090	1855.00	10	1	0	22.51	24.51	< 33.01
26365	1882.50				22.59	24.59	< 33.01
26640	1910.00				22.47	24.47	< 33.01
26090	1855.00	10	1	24	22.79	24.79	< 33.01
26365	1882.50				22.50	24.50	< 33.01
26640	1910.00				22.62	24.62	< 33.01
26090	1855.00	10	1	49	22.80	24.80	< 33.01
26365	1882.50				22.56	24.56	< 33.01
26640	1910.00				22.44	24.44	< 33.01
26090	1855.00	10	50	0	21.59	23.59	< 33.01
26365	1882.50				21.70	23.70	< 33.01
26640	1910.00				21.52	23.52	< 33.01
Note: The EIRP (dBm) = Output Power (dBm) + Antenna Gain (dBi)							

Channel No.	Frequency (MHz)	Channel Bandwidth (MHz)	RB Size	RB Offset	Output Power (dBm)	EIRP (dBm)	Limit (dBm)
QPSK							
26115	1857.50	15	1	0	22.55	24.55	< 33.01
26365	1882.50				22.47	24.47	< 33.01
26615	1907.50				22.70	24.70	< 33.01
26115	1857.50	15	1	37	22.43	24.43	< 33.01
26365	1882.50				22.55	24.55	< 33.01
26615	1907.50				22.31	24.31	< 33.01
26115	1857.50	15	1	74	22.42	24.42	< 33.01
26365	1882.50				22.55	24.55	< 33.01
26615	1907.50				22.00	24.00	< 33.01
26115	1857.50	15	75	0	21.55	23.55	< 33.01
26365	1882.50				21.63	23.63	< 33.01
26615	1907.50				21.54	23.54	< 33.01
26140	1860.00	20	1	0	22.61	24.61	< 33.01
26365	1882.50				22.82	24.82	< 33.01
26590	1905.00				22.42	24.42	< 33.01
26140	1860.00	20	1	49	22.62	24.62	< 33.01
26365	1882.50				22.81	24.81	< 33.01
26590	1905.00				22.79	24.79	< 33.01
26140	1860.00	20	1	99	22.52	24.52	< 33.01
26365	1882.50				22.46	24.46	< 33.01
26590	1905.00				22.45	24.45	< 33.01
26140	1860.00	20	100	0	21.64	23.64	< 33.01
26365	1882.50				21.60	23.60	< 33.01
26590	1905.00				21.49	23.49	< 33.01

Note: The EIRP (dBm) = Output Power (dBm) + Antenna Gain (dBi)

Product	LTE Module	Test Site	WZ-SR6
Test Engineer	Eric Xu	Test Date	2021/12/14 ~ 2021/12/23
Test Band	LTE Band 4		

Channel No.	Frequency (MHz)	Channel Bandwidth (MHz)	RB Size	RB Offset	Output Power (dBm)	EIRP (dBm)	Limit (dBm)
QPSK							
19957	1710.70	1.4	1	0	22.77	24.77	< 30.00
20175	1732.50				22.65	24.65	< 30.00
20393	1754.30				22.61	24.61	< 30.00
19957	1710.70	1.4	1	2	22.67	24.67	< 30.00
20175	1732.50				22.57	24.57	< 30.00
20393	1754.30				22.62	24.62	< 30.00
19957	1710.70	1.4	1	6	22.75	24.75	< 30.00
20175	1732.50				22.49	24.49	< 30.00
20393	1754.30				22.45	24.45	< 30.00
19957	1710.70	1.4	6	0	21.78	23.78	< 30.00
20175	1732.50				21.74	23.74	< 30.00
20393	1754.30				21.68	23.68	< 30.00
19965	1711.50	3	1	0	22.52	24.52	< 30.00
20175	1732.50				22.74	24.74	< 30.00
20385	1753.50				22.60	24.60	< 30.00
19965	1711.50	3	1	7	22.65	24.65	< 30.00
20175	1732.50				22.35	24.35	< 30.00
20385	1753.50				22.48	24.48	< 30.00
19965	1711.50	3	1	14	22.57	24.57	< 30.00
20175	1732.50				22.65	24.65	< 30.00
20385	1753.50				22.52	24.52	< 30.00
19965	1711.50	3	15	0	21.81	23.81	< 30.00
20175	1732.50				21.73	23.73	< 30.00
20385	1753.50				21.60	23.60	< 30.00

Note: The EIRP (dBm) = Output Power (dBm) + Antenna Gain (dBi)

Channel No.	Frequency (MHz)	Channel Bandwidth (MHz)	RB Size	RB Offset	Output Power (dBm)	EIRP (dBm)	Limit (dBm)
QPSK							
19975	1712.50	5	1	0	22.42	24.42	< 30.00
20175	1732.50				22.70	24.70	< 30.00
20375	1752.50				22.46	24.46	< 30.00
19975	1712.50	5	1	12	22.34	24.34	< 30.00
20175	1732.50				22.55	24.55	< 30.00
20375	1752.50				22.55	24.55	< 30.00
19975	1712.50	5	1	24	22.48	24.48	< 30.00
20175	1732.50				22.52	24.52	< 30.00
20375	1752.50				22.30	24.30	< 30.00
19975	1712.50	5	25	0	21.70	23.70	< 30.00
20175	1732.50				21.75	23.75	< 30.00
20375	1752.50				21.69	23.69	< 30.00
20000	1715.00	10	1	0	22.92	24.92	< 30.00
20175	1732.50				22.78	24.78	< 30.00
20350	1750.00				22.74	24.74	< 30.00
20000	1715.00	10	1	24	22.85	24.85	< 30.00
20175	1732.50				22.62	24.62	< 30.00
20350	1750.00				22.69	24.69	< 30.00
20000	1715.00	10	1	49	22.60	24.60	< 30.00
20175	1732.50				22.61	24.61	< 30.00
20350	1750.00				22.64	24.64	< 30.00
20000	1715.00	10	50	0	21.59	23.59	< 30.00
20175	1732.50				21.62	23.62	< 30.00
20350	1750.00				21.61	23.61	< 30.00

Note: The EIRP (dBm) = Output Power (dBm) + Antenna Gain (dBi)

Channel No.	Frequency (MHz)	Channel Bandwidth (MHz)	RB Size	RB Offset	Output Power (dBm)	EIRP (dBm)	Limit (dBm)
QPSK							
20025	1717.50	15	1	0	22.70	24.70	< 30.00
20175	1732.50				22.70	24.70	< 30.00
20325	1747.50				22.67	24.67	< 30.00
20025	1717.50	15	1	37	22.41	24.41	< 30.00
20175	1732.50				22.17	24.17	< 30.00
20325	1747.50				22.56	24.56	< 30.00
20025	1717.50	15	1	74	22.70	24.70	< 30.00
20175	1732.50				22.58	24.58	< 30.00
20325	1747.50				22.52	24.52	< 30.00
20025	1717.50	15	75	0	21.64	23.64	< 30.00
20175	1732.50				21.65	23.65	< 30.00
20325	1747.50				21.55	23.55	< 30.00
20050	1720.00	20	1	0	22.99	24.99	< 30.00
20175	1732.50				22.67	24.67	< 30.00
20300	1745.00				23.03	25.03	< 30.00
20050	1720.00	20	1	49	22.66	24.66	< 30.00
20175	1732.50				22.68	24.68	< 30.00
20300	1745.00				22.54	24.54	< 30.00
20050	1720.00	20	1	99	22.76	24.76	< 30.00
20175	1732.50				22.75	24.75	< 30.00
20300	1745.00				22.75	24.75	< 30.00
20050	1720.00	20	100	0	21.53	23.53	< 30.00
20175	1732.50				21.77	23.77	< 30.00
20300	1745.00				21.60	23.60	< 30.00

Note: The EIRP (dBm) = Output Power (dBm) + Antenna Gain (dBi)

Product	LTE Module	Test Site	WZ-SR6
Test Engineer	Eric Xu	Test Date	2021/12/14 ~ 2021/12/23
Test Band	LTE Band 5/26		

Channel No.	Frequency (MHz)	Channel Bandwidth (MHz)	RB Size	RB Offset	Output Power (dBm)	ERP (dBm)	Limit (dBm)
QPSK							
26797	824.70	1.4	1	0	22.99	22.84	< 38.45
26915	836.50				22.74	22.59	< 38.45
27033	848.30				22.84	22.69	< 38.45
26797	824.70	1.4	1	2	23.06	22.91	< 38.45
26915	836.50				22.86	22.71	< 38.45
27033	848.30				22.84	22.69	< 38.45
26797	824.70	1.4	1	6	22.81	22.66	< 38.45
26915	836.50				22.71	22.56	< 38.45
27033	848.30				22.63	22.48	< 38.45
26797	824.70	1.4	6	0	21.93	21.78	< 38.45
26915	836.50				21.99	21.84	< 38.45
27033	848.30				21.88	21.73	< 38.45
26805	825.50	3	1	0	23.25	23.10	< 38.45
26915	836.50				23.10	22.95	< 38.45
27015	846.50				22.93	22.78	< 38.45
26805	825.50	3	1	7	23.11	22.96	< 38.45
26915	836.50				22.86	22.71	< 38.45
27015	846.50				22.68	22.53	< 38.45
26805	825.50	3	1	14	23.16	23.01	< 38.45
26915	836.50				23.08	22.93	< 38.45
27015	846.50				22.78	22.63	< 38.45
26805	825.50	3	15	0	22.11	21.96	< 38.45
26915	836.50				22.02	21.87	< 38.45
27015	846.50				21.84	21.69	< 38.45

Note: The ERP (dBm) = Output Power (dBm) + Antenna Gain (dBi) - 2.15

Channel No.	Frequency (MHz)	Channel Bandwidth (MHz)	RB Size	RB Offset	Output Power (dBm)	ERP (dBm)	Limit (dBm)
QPSK							
26815	826.50	5	1	0	22.67	22.52	< 38.45
26915	836.50				22.94	22.79	< 38.45
27015	846.50				22.97	22.82	< 38.45
26815	826.50	5	1	12	22.71	22.56	< 38.45
26915	836.50				22.48	22.33	< 38.45
27015	846.50				22.50	22.35	< 38.45
26815	826.50	5	1	24	22.93	22.78	< 38.45
26915	836.50				22.75	22.60	< 38.45
27015	846.50				22.83	22.68	< 38.45
26815	826.50	5	25	0	21.97	21.82	< 38.45
26915	836.50				21.79	21.64	< 38.45
27015	846.50				21.82	21.67	< 38.45
26840	829.00	10	1	0	22.84	22.69	< 38.45
26915	836.50				23.07	22.92	< 38.45
26990	844.00				23.08	22.93	< 38.45
26840	829.00	10	1	24	22.94	22.79	< 38.45
26915	836.50				22.62	22.47	< 38.45
26990	844.00				22.94	22.79	< 38.45
26840	829.00	10	1	49	22.90	22.75	< 38.45
26915	836.50				22.67	22.52	< 38.45
26990	844.00				22.79	22.64	< 38.45
26840	829.00	10	50	0	21.79	21.64	< 38.45
26915	836.50				21.81	21.66	< 38.45
26990	844.00				21.82	21.67	< 38.45

Note: The ERP (dBm) = Output Power (dBm) + Antenna Gain (dBi) - 2.15

Channel No.	Frequency (MHz)	Channel Bandwidth (MHz)	RB Size	RB Offset	Output Power (dBm)	ERP (dBm)	Limit (dBm)
QPSK							
26765	821.50	15	1	0	23.01	22.86	< 38.45
26915	836.50				22.87	22.72	< 38.45
26965	841.50				23.02	22.87	< 38.45
26765	821.50	15	1	37	22.73	22.58	< 38.45
26915	836.50				22.65	22.50	< 38.45
26965	841.50				22.63	22.48	< 38.45
26765	821.50	15	1	74	23.03	22.88	< 38.45
26915	836.50				22.75	22.60	< 38.45
26965	841.50				22.82	22.67	< 38.45
26765	821.50	15	75	0	21.98	21.83	< 38.45
26915	836.50				21.90	21.75	< 38.45
26965	841.50				21.80	21.65	< 38.45
Note: The ERP (dBm) = Output Power (dBm) + Antenna Gain (dBi) - 2.15							

Product	LTE Module	Test Site	WZ-SR6
Test Engineer	Eric Xu	Test Date	2021/12/14 ~ 2021/12/23
Test Band	LTE Band 7		

Channel No.	Frequency (MHz)	Channel Bandwidth (MHz)	RB Size	RB Offset	Output Power (dBm)	EIRP (dBm)	Limit (dBm)
QPSK							
20775	2502.50	5	1	0	22.23	25.23	< 33.01
21100	2535.00				22.25	25.25	< 33.01
21425	2567.50				22.15	25.15	< 33.01
20775	2502.50	5	1	12	22.03	25.03	< 33.01
21100	2535.00				22.26	25.26	< 33.01
21425	2567.50				22.14	25.14	< 33.01
20775	2502.50	5	1	24	22.09	25.09	< 33.01
21100	2535.00				22.54	25.54	< 33.01
21425	2567.50				22.09	25.09	< 33.01
20775	2502.50	5	25	0	21.28	24.28	< 33.01
21100	2535.00				21.26	24.26	< 33.01
21425	2567.50				21.20	24.20	< 33.01
20800	2505.00	10	1	0	22.21	25.21	< 33.01
21100	2535.00				22.27	25.27	< 33.01
21400	2565.00				22.17	25.17	< 33.01
20800	2505.00	10	1	24	22.13	25.13	< 33.01
21100	2535.00				22.27	25.27	< 33.01
21400	2565.00				22.48	25.48	< 33.01
20800	2505.00	10	1	49	22.30	25.30	< 33.01
21100	2535.00				22.34	25.34	< 33.01
21400	2565.00				22.05	25.05	< 33.01
20800	2505.00	10	50	0	21.33	24.33	< 33.01
21100	2535.00				21.42	24.42	< 33.01
21400	2565.00				21.15	24.15	< 33.01

Note: The EIRP (dBm) = Output Power (dBm) + Antenna Gain (dBi)

Channel No.	Frequency (MHz)	Channel Bandwidth (MHz)	RB Size	RB Offset	Output Power (dBm)	EIRP (dBm)	Limit (dBm)
QPSK							
20825	2507.50	15	1	0	22.44	25.44	< 33.01
21100	2535.00				22.22	25.22	< 33.01
21375	2562.50				22.24	25.24	< 33.01
20825	2507.50	15	1	37	22.25	25.25	< 33.01
21100	2535.00				22.02	25.02	< 33.01
21375	2562.50				22.00	25.00	< 33.01
20825	2507.50	15	1	74	22.32	25.32	< 33.01
21100	2535.00				22.22	25.22	< 33.01
21375	2562.50				22.19	25.19	< 33.01
20825	2507.50	15	75	0	21.22	24.22	< 33.01
21100	2535.00				21.35	24.35	< 33.01
21375	2562.50				21.17	24.17	< 33.01
20850	2510.00	20	1	0	22.50	25.50	< 33.01
21100	2535.00				22.52	25.52	< 33.01
21350	2560.00				22.39	25.39	< 33.01
20850	2510.00	20	1	49	22.86	25.86	< 33.01
21100	2535.00				22.55	25.55	< 33.01
21350	2560.00				22.17	25.17	< 33.01
20850	2510.00	20	1	99	22.55	25.55	< 33.01
21100	2535.00				22.50	25.50	< 33.01
21350	2560.00				22.17	25.17	< 33.01
20850	2510.00	20	100	0	21.36	24.36	< 33.01
21100	2535.00				21.26	24.26	< 33.01
21350	2560.00				21.31	24.31	< 33.01

Note: The EIRP (dBm) = Output Power (dBm) + Antenna Gain (dBi)

Product	LTE Module	Test Site	WZ-SR6
Test Engineer	Eric Xu	Test Date	2021/12/14 ~ 2021/12/23
Test Band	LTE Band 12		

Channel No.	Frequency (MHz)	Channel Bandwidth (MHz)	RB Size	RB Offset	Output Power (dBm)	ERP (dBm)	Limit (dBm)
QPSK							
23017	699.7	1.4	1	0	22.80	23.65	< 33.01
23095	707.5				22.94	23.79	< 33.01
23173	715.3				22.71	23.56	< 33.01
23017	699.7	1.4	1	2	22.84	23.69	< 33.01
23095	707.5				22.92	23.77	< 33.01
23173	715.3				22.93	23.78	< 33.01
23017	699.7	1.4	1	6	22.74	23.59	< 33.01
23095	707.5				22.84	23.69	< 33.01
23173	715.3				22.85	23.70	< 33.01
23017	699.7	1.4	6	0	21.90	22.75	< 33.01
23095	707.5				21.89	22.74	< 33.01
23173	715.3				21.84	22.69	< 33.01
23025	700.5	3	1	0	22.76	23.61	< 33.01
23095	707.5				22.82	23.67	< 33.01
23165	714.5				22.79	23.64	< 33.01
23025	700.5	3	1	7	22.62	23.47	< 33.01
23095	707.5				22.72	23.57	< 33.01
23165	714.5				22.56	23.41	< 33.01
23025	700.5	3	1	14	22.76	23.61	< 33.01
23095	707.5				22.63	23.48	< 33.01
23165	714.5				22.64	23.49	< 33.01
23025	700.5	3	15	0	21.83	22.68	< 33.01
23095	707.5				21.89	22.74	< 33.01
23165	714.5				21.75	22.60	< 33.01

Note: The ERP (dBm) = Output Power (dBm) + Antenna Gain (dBi) - 2.15

Channel No.	Frequency (MHz)	Channel Bandwidth (MHz)	RB Size	RB Offset	Output Power (dBm)	ERP (dBm)	Limit (dBm)
QPSK							
23035	701.5	5	1	0	22.48	23.33	< 33.01
23095	707.5				22.74	23.59	< 33.01
23155	713.5				22.70	23.55	< 33.01
23035	701.5	5	1	12	22.46	23.31	< 33.01
23095	707.5				22.73	23.58	< 33.01
23155	713.5				22.58	23.43	< 33.01
23035	701.5	5	1	24	22.55	23.40	< 33.01
23095	707.5				22.72	23.57	< 33.01
23155	713.5				22.72	23.57	< 33.01
23035	701.5	5	25	0	21.86	22.71	< 33.01
23095	707.5				21.91	22.76	< 33.01
23155	713.5				21.88	22.73	< 33.01
23060	704.0	10	1	0	22.74	23.59	< 33.01
23095	707.5				22.63	23.48	< 33.01
23130	711.0				23.15	24.00	< 33.01
23060	704.0	10	1	24	22.70	23.55	< 33.01
23095	707.5				23.02	23.87	< 33.01
23130	711.0				22.87	23.72	< 33.01
23060	704.0	10	1	49	22.45	23.30	< 33.01
23095	707.5				22.77	23.62	< 33.01
23130	711.0				22.83	23.68	< 33.01
23060	704.0	10	50	0	21.87	22.72	< 33.01
23095	707.5				21.95	22.80	< 33.01
23130	711.0				21.86	22.71	< 33.01

Note: The ERP (dBm) = Output Power (dBm) + Antenna Gain (dBi) - 2.15

Product	LTE Module	Test Site	WZ-SR6
Test Engineer	Eric Xu	Test Date	2021/12/14 ~ 2021/12/23
Test Band	LTE Band 13		

Channel No.	Frequency (MHz)	Channel Bandwidth (MHz)	RB Size	RB Offset	Output Power (dBm)	ERP (dBm)	Limit (dBm)
QPSK							
23205	779.5	5	1	0	22.86	24.71	< 33.01
23230	782.0				22.62	24.47	< 33.01
23255	784.5				22.89	24.74	< 33.01
23205	779.5	5	1	12	22.75	24.60	< 33.01
23230	782.0				22.47	24.32	< 33.01
23255	784.5				22.91	24.76	< 33.01
23205	779.5	5	1	24	22.88	24.73	< 33.01
23230	782.0				22.72	24.57	< 33.01
23255	784.5				22.87	24.72	< 33.01
23205	779.5	5	25	0	21.88	23.73	< 33.01
23230	782.0				21.83	23.68	< 33.01
23255	784.5				21.85	23.70	< 33.01
23230	782.0	10	1	0	22.75	24.60	< 33.01
23230	782.0		1	24	22.80	24.65	< 33.01
23230	782.0		1	49	22.83	24.68	< 33.01
23230	782.0		50	0	21.95	23.80	< 33.01

Note: The ERP (dBm) = Output Power (dBm) + Antenna Gain (dBi) - 2.15

Product	LTE Module	Test Site	WZ-SR6
Test Engineer	Eric Xu	Test Date	2021/12/14 ~ 2021/12/23
Test Band	LTE Band 26		

Channel No.	Frequency (MHz)	Channel Bandwidth (MHz)	RB Size	RB Offset	Output Power (dBm)	Output Power (W)	Limit (W)
QPSK							
26697	814.7	1.4	1	0	22.98	0.1986	< 100
26740	819.0				22.75	0.1884	< 100
26783	823.3				22.93	0.1963	< 100
26697	814.7	1.4	1	2	22.92	0.1959	< 100
26740	819.0				22.84	0.1923	< 100
26783	823.3				22.97	0.1982	< 100
26697	814.7	1.4	1	6	22.83	0.1919	< 100
26740	819.0				22.73	0.1875	< 100
26783	823.3				22.84	0.1923	< 100
26697	814.7	1.4	6	0	21.93	0.1560	< 100
26740	819.0				21.83	0.1524	< 100
26783	823.3				21.91	0.1552	< 100
26705	815.5	3	1	0	22.79	0.1901	< 100
26740	819.0				22.90	0.1950	< 100
26775	822.5				22.92	0.1959	< 100
26705	815.5	3	1	7	22.87	0.1936	< 100
26740	819.0				22.59	0.1816	< 100
26775	822.5				22.72	0.1871	< 100
26705	815.5	3	1	14	22.82	0.1914	< 100
26740	819.0				22.54	0.1795	< 100
26775	822.5				22.91	0.1954	< 100
26705	815.5	3	15	0	21.58	0.1439	< 100
26740	819.0				21.74	0.1493	< 100
26775	822.5				21.89	0.1545	< 100

Channel No.	Frequency (MHz)	Channel Bandwidth (MHz)	RB Size	RB Offset	Output Power (dBm)	Output Power (W)	Limit (W)
QPSK							
26715	816.5	5	1	0	22.70	0.1862	< 100
26740	819.0				22.82	0.1914	< 100
26765	821.5				22.88	0.1941	< 100
26715	816.5	5	1	12	22.63	0.1832	< 100
26740	819.0				22.85	0.1928	< 100
26765	821.5				22.78	0.1897	< 100
26715	816.5	5	1	24	22.68	0.1854	< 100
26740	819.0				22.92	0.1959	< 100
26765	821.5				22.66	0.1845	< 100
26715	816.5	5	25	0	21.82	0.1521	< 100
26740	819.0				21.89	0.1545	< 100
26765	821.5				21.89	0.1545	< 100
26740	819.0	10	1	0	22.64	0.1837	< 100
			1	24	22.62	0.1828	< 100
			1	49	22.75	0.1884	< 100
			50	0	21.80	0.1514	< 100

5.3. Radiated Spurious Emission Measurement

5.3.1. Test Limit

The power of any emission outside of the authorized operating frequency ranges must be attenuated below the transmitting power (P) by a factor of at least $43 + 10 \log(P)$ dB. The emission limit equal to -13dBm.

For Band 7, the power of any emission outside of the authorized operating frequency ranges must be attenuated below the transmitting power (P) by a factor of at least $55 + 10 \log(P)$ dB. The emission limit equal to -25dBm.

For LTE Band 13, For operations in the 746-758 MHz, 775-788 MHz, and 805-806 MHz bands, emissions in the band 1559-1610 MHz shall be limited to -70 dBW/MHz (-40dBm/MHz) equivalent isotropically radiated power (EIRP) for wideband signals, and -80 dBW (-50dBm) EIRP for discrete emissions of less than 700 Hz bandwidth.

E (dB μ V/m) = EIRP (dBm) - 20 log D + 104.8; where D is the measurement distance in meters. The emission limit equal to 82.3dB μ V/m or 70.3dB μ V/m.

5.3.2. Test Procedure

ANSI C63.26-2015 - Section 5.2.7 & 5.5

5.3.3. Test Setting

1. RBW = 1MHz
2. VBW \geq 3*RBW
3. Sweep time \geq 10 \times (number of points in sweep) \times (transmission symbol period)
4. Detector = Peak
5. Trace mode = max hold
6. The trace was allowed to stabilize

5.3.4. Test Setup

Below 1GHz Test Setup:

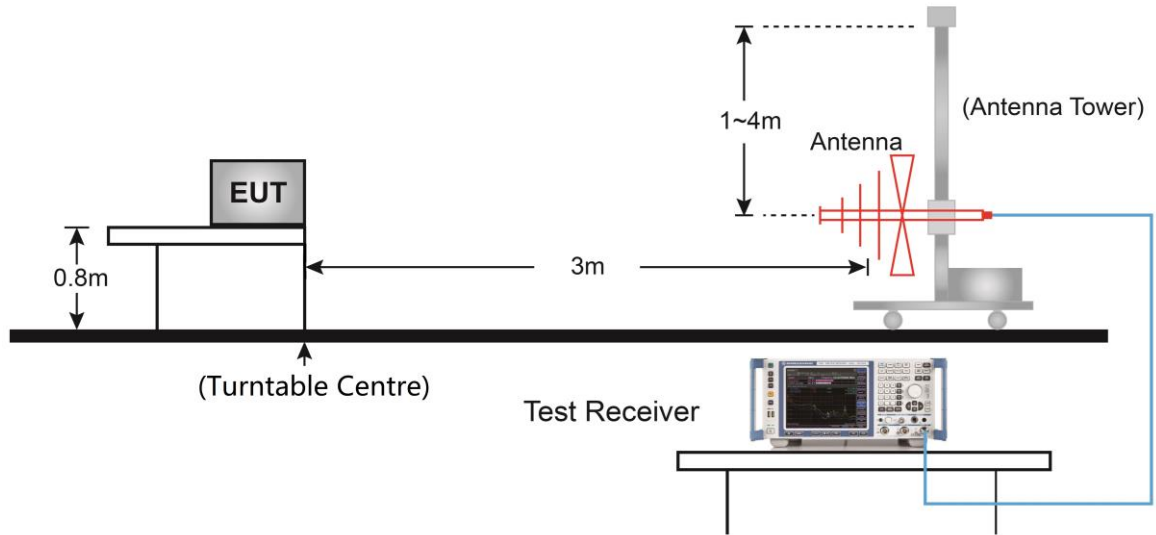

Above 1GHz Test Setup:

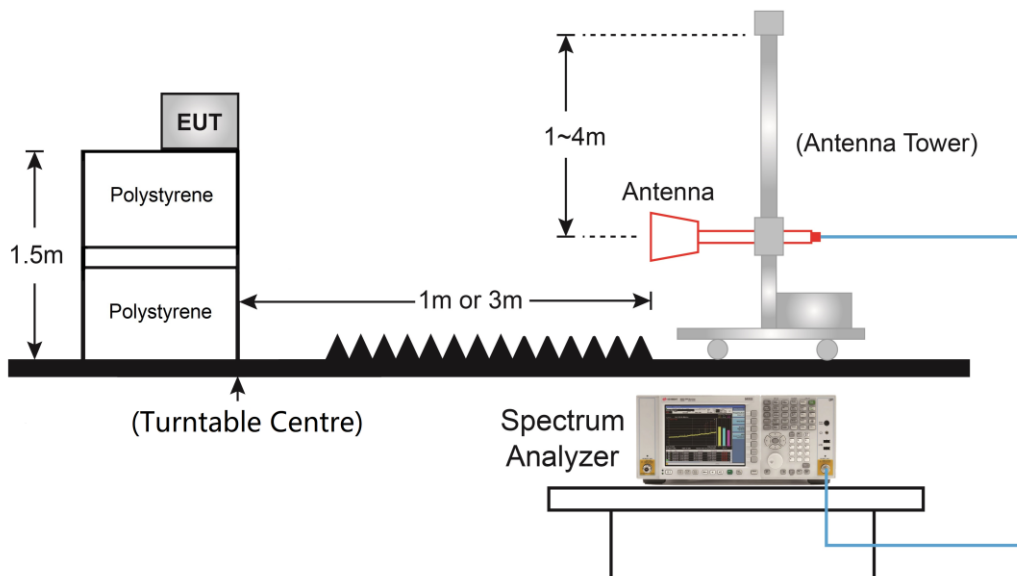

5.3.5. Test Result

Product	LTE Module	Test Site	WZ-AC1
Test Engineer	Bob Zhang	Test Date	2021/12/14 ~ 2021/12/23
Test Band	LTE Band 2/25_1RB_QPSK		

Frequency (MHz)	Reading Level (dBμV)	Factor (dB)	Measure Level (dBμV/m)	Limit (dBμV/m)	Margin (dB)	Detector	Polarization
Low Channel							
411.695	19.1	20.9	40.0	82.3	-42.3	PK	Horizontal
490.265	15.8	22.8	38.6	82.3	-43.7	PK	Horizontal
185.200	9.6	15.6	25.2	82.3	-57.1	PK	Vertical
489.295	10.0	22.8	32.8	82.3	-49.5	PK	Vertical
4281.000	39.2	2.4	41.6	82.3	-40.7	PK	Horizontal
5547.500	40.1	4.7	44.8	82.3	-37.5	PK	Horizontal
5547.500	47.1	4.7	51.8	82.3	-30.5	PK	Vertical
7400.500	43.1	9.1	52.2	82.3	-30.1	PK	Vertical
Middle Channel							
417.030	18.2	21.1	39.3	82.3	-43.0	PK	Horizontal
488.325	16.2	22.8	39.0	82.3	-43.3	PK	Horizontal
404.905	10.8	20.8	31.6	82.3	-50.7	PK	Vertical
490.750	10.0	22.8	32.8	82.3	-49.5	PK	Vertical
5649.500	39.3	4.9	44.2	82.3	-38.1	PK	Horizontal
8820.000	35.8	11.2	47.0	82.3	-35.3	PK	Horizontal
5649.500	50.5	4.9	55.4	82.3	-26.9	PK	Vertical
7528.000	41.0	8.7	49.7	82.3	-32.6	PK	Vertical
High Channel							
413.150	18.6	21.0	39.6	82.3	-42.7	PK	Horizontal
489.295	16.4	22.8	39.2	82.3	-43.1	PK	Horizontal
413.635	10.8	21.0	31.8	82.3	-50.5	PK	Vertical
486.385	9.7	22.8	32.5	82.3	-49.8	PK	Vertical
5743.000	39.2	5.3	44.5	82.3	-37.8	PK	Horizontal
9109.000	36.9	11.7	48.6	82.3	-33.7	PK	Horizontal
5743.000	48.6	5.3	53.9	82.3	-28.4	PK	Vertical
7655.500	43.3	8.7	52.0	82.3	-30.3	PK	Vertical

Note: Measure Level (dBμV/m) = Reading Level (dBμV) + Factor (dB).

Factor (dB/m) = Cable Loss (dB) + Antenna Factor (dB/m)

Product	LTE Module	Test Site	WZ-AC1
Test Engineer	Bob Zhang	Test Date	2021/12/14 ~ 2021/12/23
Test Band	LTE Band 4_1RB_QPSK		

Frequency (MHz)	Reading Level (dBμV)	Factor (dB)	Measure Level (dBμV/m)	Limit (dBμV/m)	Margin (dB)	Detector	Polarization
Low Channel							
403.935	18.1	20.7	38.8	82.3	-43.5	PK	Horizontal
489.780	16.4	22.8	39.2	82.3	-43.1	PK	Horizontal
183.260	8.2	15.8	24.0	82.3	-58.3	PK	Vertical
492.205	9.5	22.8	32.3	82.3	-50.0	PK	Vertical
3422.500	46.1	-0.2	45.9	82.3	-36.4	PK	Horizontal
7239.000	39.1	9.3	48.4	82.3	-33.9	PK	Horizontal
5131.000	51.7	4.8	56.5	82.3	-25.8	PK	Vertical
6839.500	42.6	8.0	50.6	82.3	-31.7	PK	Vertical
Middle Channel							
412.665	18.8	21.0	39.8	82.3	-42.5	PK	Horizontal
489.780	16.5	22.8	39.3	82.3	-43.0	PK	Horizontal
46.975	9.7	18.8	28.5	82.3	-53.8	PK	Vertical
486.385	9.4	22.8	32.2	82.3	-50.1	PK	Vertical
7128.500	38.8	8.8	47.6	82.3	-34.7	PK	Horizontal
10163.000	37.9	13.4	51.3	82.3	-31.0	PK	Horizontal
5199.000	47.3	4.9	52.2	82.3	-30.1	PK	Vertical
6924.500	44.2	8.1	52.3	82.3	-30.0	PK	Vertical
High Channel							
415.090	18.4	21.0	39.4	82.3	-42.9	PK	Horizontal
490.750	16.6	22.8	39.4	82.3	-42.9	PK	Horizontal
64.920	5.8	16.9	22.7	82.3	-59.6	PK	Vertical
489.295	9.3	22.8	32.1	82.3	-50.2	PK	Vertical
3507.500	44.3	0.1	44.4	82.3	-37.9	PK	Horizontal
6499.500	39.3	7.2	46.5	82.3	-35.8	PK	Horizontal
5267.000	47.6	4.9	52.5	82.3	-29.8	PK	Vertical
7018.000	44.8	8.3	53.1	82.3	-29.2	PK	Vertical

Note: Measure Level (dBμV/m) = Reading Level (dBμV) + Factor (dB).

Factor (dB/m) = Cable Loss (dB) + Antenna Factor (dB/m)

Product	LTE Module	Test Site	WZ-AC1
Test Engineer	Bob Zhang	Test Date	2021/12/14 ~ 2021/12/23
Test Band	LTE Band 5/26 (824 ~ 849) _1RB_QPSK		

Frequency (MHz)	Reading Level (dBμV)	Factor (dB)	Measure Level (dBμV/m)	Limit (dBμV/m)	Margin (dB)	Detector	Polarization
Low Channel							
165.315	3.6	17.9	21.5	82.3	-60.8	PK	Horizontal
911.730	4.4	29.8	34.2	82.3	-48.1	PK	Horizontal
172.590	3.5	17.3	20.8	82.3	-61.5	PK	Vertical
943.255	4.7	30.0	34.7	82.3	-47.6	PK	Vertical
1646.000	45.6	-6.3	39.3	82.3	-43.0	PK	Horizontal
3601.000	42.1	0.3	42.4	82.3	-39.9	PK	Horizontal
1646.000	48.1	-6.3	41.8	82.3	-40.5	PK	Vertical
3609.500	41.3	0.3	41.6	82.3	-40.7	PK	Vertical
Middle Channel							
172.590	3.9	17.3	21.2	82.3	-61.1	PK	Horizontal
973.325	4.9	30.4	35.3	82.3	-47.0	PK	Horizontal
167.740	4.5	17.7	22.2	82.3	-60.1	PK	Vertical
655.650	3.0	26.4	29.4	82.3	-52.9	PK	Vertical
1671.500	45.0	-6.2	38.8	82.3	-43.5	PK	Horizontal
3754.000	40.8	0.9	41.7	82.3	-40.6	PK	Horizontal
1671.500	48.6	-6.2	42.4	82.3	-39.9	PK	Vertical
2504.500	44.9	-2.6	42.3	82.3	-40.0	PK	Vertical
High Channel							
172.590	3.1	17.3	20.4	82.3	-61.9	PK	Horizontal
951.015	4.2	30.1	34.3	82.3	-48.0	PK	Horizontal
162.890	3.0	18.0	21.0	82.3	-61.3	PK	Vertical
418.970	4.3	21.2	25.5	82.3	-56.8	PK	Vertical
1697.000	46.5	-6.2	40.3	82.3	-42.0	PK	Horizontal
3694.500	40.9	0.7	41.6	82.3	-40.7	PK	Horizontal
1697.000	50.4	-6.2	44.2	82.3	-38.1	PK	Vertical
2547.000	43.2	-2.4	40.8	82.3	-41.5	PK	Vertical

Note: Measure Level (dBμV/m) = Reading Level (dBμV) + Factor (dB).

Factor (dB/m) = Cable Loss (dB) + Antenna Factor (dB/m)

Product	LTE Module	Test Site	WZ-AC1
Test Engineer	Bob Zhang	Test Date	2021/12/14 ~ 2021/12/23
Test Band	LTE Band 7_1RB_QPSK		

Frequency (MHz)	Reading Level (dBμV)	Factor (dB)	Measure Level (dBμV/m)	Limit (dBμV/m)	Margin (dB)	Detector	Polarization
Low Channel							
413.635	18.5	21.0	39.5	70.3	-30.8	Peak	Horizontal
488.810	17.0	22.8	39.8	70.3	-30.5	Peak	Horizontal
488.810	9.3	22.8	32.1	70.3	-38.2	Peak	Vertical
844.800	4.6	29.1	33.7	70.3	-36.6	Peak	Vertical
7502.500	45.4	8.9	54.3	70.3	-16.0	Peak	Horizontal
10834.500	37.3	13.9	51.2	70.3	-19.1	Peak	Horizontal
5003.500	44.1	4.5	48.6	70.3	-21.7	Peak	Vertical
7502.500	52.6	8.9	61.5	70.3	-8.8	Peak	Vertical
Middle Channel							
411.210	18.3	20.9	39.2	70.3	-31.1	Peak	Horizontal
487.840	16.2	22.8	39.0	70.3	-31.3	Peak	Horizontal
404.905	10.5	20.8	31.3	70.3	-39.0	Peak	Vertical
484.930	9.6	22.8	32.4	70.3	-37.9	Peak	Vertical
7596.000	47.4	8.6	56.0	70.3	-14.3	Peak	Horizontal
9015.500	39.6	11.5	51.1	70.3	-19.2	Peak	Horizontal
5063.000	44.2	4.7	48.9	70.3	-21.4	Peak	Vertical
7596.000	49.1	8.6	57.7	70.3	-12.6	Average	Vertical
High Channel							
411.695	18.5	20.9	39.4	70.3	-30.9	Peak	Horizontal
488.810	16.1	22.8	38.9	70.3	-31.4	Peak	Horizontal
413.150	10.7	21.0	31.7	70.3	-38.6	Peak	Vertical
488.325	9.9	22.8	32.7	70.3	-37.6	Peak	Vertical
7706.500	44.0	8.7	52.7	70.3	-17.6	Peak	Horizontal
14617.000	35.7	15.0	50.7	70.3	-19.6	Peak	Horizontal
5139.500	43.2	4.8	48.0	70.3	-22.3	Peak	Vertical
7706.500	54.5	8.7	63.2	70.3	-7.1	Peak	Vertical

Note: Measure Level (dBμV/m) = Reading Level (dBμV) + Factor (dB).

Factor (dB/m) = Cable Loss (dB) + Antenna Factor (dB/m)

Product	LTE Module	Test Site	WZ-AC1
Test Engineer	Bob Zhang	Test Date	2021/12/14 ~ 2021/12/23
Test Band	LTE Band 12, 1RB, QPSK		

Frequency (MHz)	Reading Level (dBμV)	Factor (dB)	Measure Level (dBμV/m)	Limit (dBμV/m)	Margin (dB)	Detector	Polarization
Low Channel							
409.755	17.9	20.9	38.8	82.3	-43.5	PK	Horizontal
492.205	16.5	22.8	39.3	82.3	-43.0	PK	Horizontal
406.845	17.8	20.8	38.6	82.3	-43.7	PK	Vertical
491.235	16.8	22.8	39.6	82.3	-42.7	PK	Vertical
1399.500	51.2	-5.9	45.3	82.3	-37.0	PK	Horizontal
3499.000	45.4	0.1	45.5	82.3	-36.8	PK	Horizontal
3499.000	50.2	0.1	50.3	82.3	-32.0	PK	Vertical
4196.000	51.5	2.1	53.6	82.3	-28.7	PK	Vertical
Middle Channel							
408.785	18.0	20.9	38.9	82.3	-43.4	PK	Horizontal
491.235	15.6	22.8	38.4	82.3	-43.9	PK	Horizontal
415.090	15.2	21.0	36.2	82.3	-46.1	PK	Vertical
489.295	9.6	22.8	32.4	82.3	-49.9	PK	Vertical
1416.500	56.4	-5.9	50.5	82.3	-31.8	PK	Horizontal
4247.000	44.3	2.2	46.5	82.3	-35.8	PK	Horizontal
1416.500	57.8	-5.9	51.9	82.3	-30.4	PK	Vertical
4238.500	57.7	2.1	59.8	82.3	-22.5	PK	Vertical
High Channel							
411.695	18.6	20.9	39.5	82.3	-42.8	PK	Horizontal
490.265	15.5	22.8	38.3	82.3	-44.0	PK	Horizontal
409.755	12.4	20.9	33.3	82.3	-49.0	PK	Vertical
492.205	8.4	22.8	31.2	82.3	-51.1	PK	Vertical
1433.500	60.2	-5.9	54.3	82.3	-28.0	PK	Horizontal
4298.000	43.7	2.5	46.2	82.3	-36.1	PK	Horizontal
1433.500	59.8	-5.9	53.9	82.3	-28.4	PK	Vertical
4298.000	55.9	2.5	58.4	82.3	-23.9	PK	Vertical

Note: Measure Level (dBμV/m) = Reading Level (dBμV) + Factor (dB).

Factor (dB/m) = Cable Loss (dB) + Antenna Factor (dB/m)

Product	LTE Module	Test Site	WZ-AC1
Test Engineer	Bob Zhang	Test Date	2021/12/14 ~ 2021/12/23
Test Band	LTE Band 13, 1RB, QPSK		

Frequency (MHz)	Reading Level (dBμV)	Factor (dB)	Measure Level (dBμV/m)	Limit (dBμV/m)	Margin (dB)	Detector	Polarization
Low Channel							
185.200	12.5	15.6	28.1	82.3	-54.2	PK	Horizontal
388.415	22.2	20.5	42.7	82.3	-39.6	PK	Horizontal
388.900	14.2	20.5	34.7	82.3	-47.6	PK	Vertical
905.910	4.5	29.7	34.2	82.3	-48.1	PK	Vertical
1578.000	41.2	-6.1	35.1	55.3	-20.2	PK	Horizontal
2334.500	41.8	-2.9	38.9	82.3	-43.4	PK	Horizontal
1595.000	40.6	-6.2	34.4	55.3	-20.9	PK	Vertical
2334.500	44.9	-2.9	42.0	82.3	-40.3	PK	Vertical
Middle Channel							
408.785	18.9	20.9	39.8	82.3	-42.5	PK	Horizontal
491.235	17.0	22.8	39.8	82.3	-42.5	PK	Horizontal
404.905	11.1	20.8	31.9	82.3	-50.4	PK	Vertical
973.810	4.6	30.4	35.0	82.3	-47.3	PK	Vertical
1561.000	43.1	-6.1	37.0	55.3	-18.3	PK	Horizontal
2343.000	41.9	-2.9	39.0	82.3	-43.3	PK	Horizontal
1561.000	47.3	-6.1	41.2	55.3	-14.1	PK	Vertical
2343.000	45.7	-2.9	42.8	82.3	-39.5	PK	Vertical
High Channel							
404.905	18.3	20.8	39.1	82.3	-43.2	PK	Horizontal
488.325	15.5	22.8	38.3	82.3	-44.0	PK	Horizontal
407.815	9.5	20.8	30.3	82.3	-52.0	PK	Vertical
486.870	7.9	22.8	30.7	82.3	-51.6	PK	Vertical
1569.500	42.5	-6.1	36.4	55.3	-18.9	PK	Horizontal
4825.000	38.1	3.8	41.9	82.3	-40.4	PK	Horizontal
1569.500	46.9	-6.1	40.8	55.3	-14.5	PK	Vertical
2360.000	44.9	-3.0	41.9	82.3	-40.4	PK	Vertical

Note: Measure Level (dBμV/m) = Reading Level (dBμV) + Factor (dB).

Factor (dB/m) = Cable Loss (dB) + Antenna Factor (dB/m)

Product	LTE Module	Test Site	WZ-AC1
Test Engineer	Bob Zhang	Test Date	2021/12/14 ~ 2021/12/23
Test Band	LTE Band 26 (814 ~ 824), 1RB, QPSK		

Frequency (MHz)	Reading Level (dBμV)	Factor (dB)	Measure Level (dBμV/m)	Limit (dBμV/m)	Margin (dB)	Detector	Polarization
Low Channel							
494.145	4.3	22.9	27.2	82.3	-55.1	PK	Horizontal
940.830	4.4	30.0	34.4	82.3	-47.9	PK	Horizontal
451.950	3.9	22.3	26.2	82.3	-56.1	PK	Vertical
941.315	4.1	30.0	34.1	82.3	-48.2	PK	Vertical
1629.000	49.6	-6.3	43.3	82.3	-39.0	PK	Horizontal
3873.000	39.7	1.3	41.0	82.3	-41.3	PK	Horizontal
1629.000	50.1	-6.3	43.8	82.3	-38.5	PK	Vertical
3261.000	40.4	-0.3	40.1	82.3	-42.2	PK	Vertical
Middle Channel							
516.940	4.7	23.5	28.2	82.3	-54.1	PK	Horizontal
942.285	5.3	30.0	35.3	82.3	-47.0	PK	Horizontal
167.740	3.6	17.7	21.3	82.3	-61.0	PK	Vertical
719.185	4.6	27.2	31.8	82.3	-50.5	PK	Vertical
1637.500	48.0	-6.3	41.7	82.3	-40.6	PK	Horizontal
2411.000	42.9	-2.9	40.0	82.3	-42.3	PK	Horizontal
1637.500	50.7	-6.3	44.4	82.3	-37.9	PK	Vertical
3788.000	40.1	1.0	41.1	82.3	-41.2	PK	Vertical
High Channel							
693.965	5.2	26.8	32.0	82.3	-50.3	PK	Horizontal
993.695	3.6	30.5	34.1	82.3	-48.2	PK	Horizontal
693.965	5.2	26.8	32.0	82.3	-50.3	PK	Vertical
993.695	3.6	30.5	34.1	82.3	-48.2	PK	Vertical
1646.000	44.8	-6.3	38.5	82.3	-43.8	PK	Horizontal
3201.500	39.8	-0.2	39.6	82.3	-42.7	PK	Horizontal
1646.000	49.0	-6.3	42.7	82.3	-39.6	PK	Vertical
4833.500	38.6	3.8	42.4	82.3	-39.9	PK	Vertical

Note: Measure Level (dBμV/m) = Reading Level (dBμV) + Factor (dB).

Factor (dB/m) = Cable Loss (dB) + Antenna Factor (dB/m)

Appendix A - Test Setup Photograph

Refer to "2112RSU024-UT" file.

Appendix B - EUT Photograph

Refer to "2112RSU024-UE" file.

The End