

EC25 Series

Hardware Design

LTE Standard Module Series

Version: 2.4.2

Date: 2021-04-08

Status: Preliminary

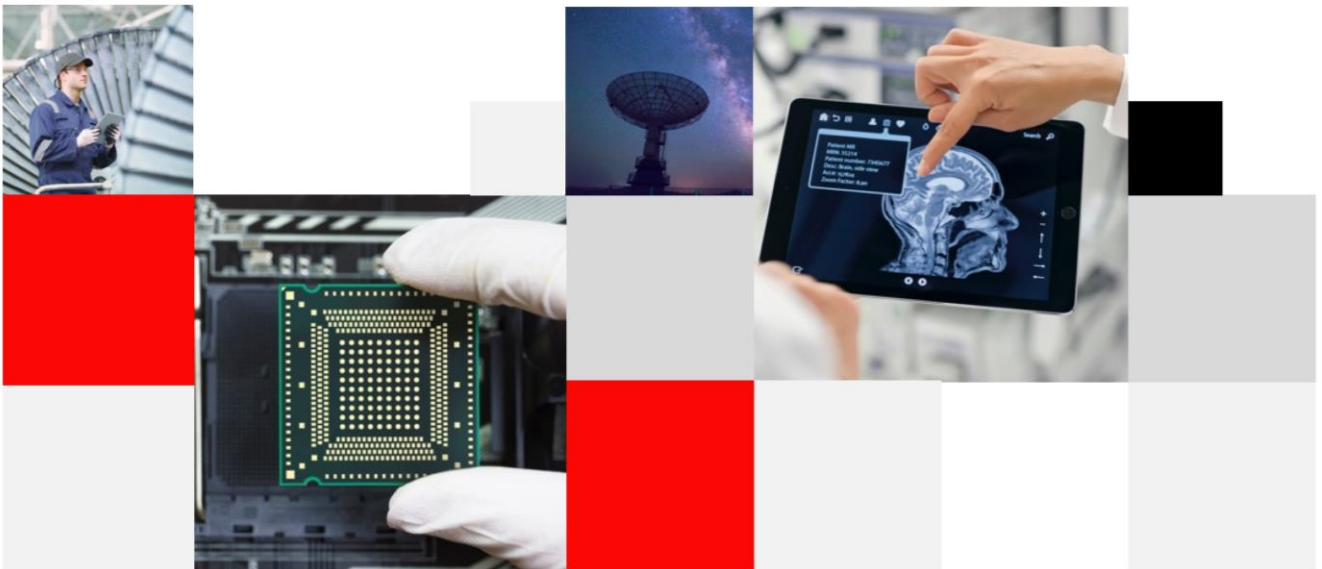

Build a Smarter World

Our aim is to provide customers with timely and comprehensive service. For any assistance, please contact our company headquarters:

Quectel Wireless Solutions Co., Ltd.

Building 5, Shanghai Business Park Phase III (Area B), No.1016 Tianlin Road, Minhang District, Shanghai 200233, China

Tel: +86 21 5108 6236

Email: info@quectel.com

Or our local office. For more information, please visit:

<http://www.quectel.com/support/sales.htm>.

For technical support, or to report documentation errors, please visit:

<http://www.quectel.com/support/technical.htm>

Or email to support@quectel.com.

General Notes

Quectel offers the information as a service to its customers. The information provided is based upon customers' requirements. Quectel makes every effort to ensure the quality of the information it makes available. Quectel does not make any warranty as to the information contained herein, and does not accept any liability for any injury, loss or damage of any kind incurred by use of or reliance upon the information. All information supplied herein is subject to change without prior notice.

Disclaimer

While Quectel has made efforts to ensure that the functions and features under development are free from errors, it is possible that these functions and features could contain errors, inaccuracies and omissions. Unless otherwise provided by valid agreement, Quectel makes no warranties of any kind, implied or express, with respect to the use of features and functions under development. To the maximum extent permitted by law, Quectel excludes all liability for any loss or damage suffered in connection with the use of the functions and features under development, regardless of whether such loss or damage may have been foreseeable.

Duty of Confidentiality

The Receiving Party shall keep confidential all documentation and information provided by Quectel, except when the specific permission has been granted by Quectel. The Receiving Party shall not access or use Quectel's documentation and information for any purpose except as expressly provided herein. Furthermore, the Receiving Party shall not disclose any of the Quectel's documentation and information to any third party without the prior written consent by Quectel. For any noncompliance to the above requirements, unauthorized use, or other illegal or malicious use of the documentation and information, Quectel will reserve the right to take legal action.

Copyright

The information contained here is proprietary technical information of Quectel. Transmitting, reproducing, disseminating and editing this document as well as using the content without permission are forbidden. Offenders will be held liable for payment of damages. All rights are reserved in the event of a patent grant or registration of a utility model or design.

Copyright © Quectel Wireless Solutions Co., Ltd. 2021. All rights reserved.

About the Document

Revision History

Version	Date	Author	Description
1.0	2016-04-01	Woody WU	Initial
1.1	2016-09-22	Lyndon LIU/ Frank WANG	<ol style="list-style-type: none"> 1. Updated EC25 series frequency bands in Table 1. 2. Updated transmitting power, supported maximum baud rate of main UART/internal protocols/USB drivers of USB interface, firmware upgrade and temperature range in Table 2. 3. Updated timing of turning on module in Figure 12. 4. Updated timing of turning off module in Figure 13. 5. Updated timing of resetting module in Figure 16. 6. Updated supported baud rates of main UART in Chapter 3.11. 7. Added notes for ADC interface in Chapter 3.13. 8. Updated GNSS performance in Table 21. 9. Updated operating frequencies of module in Table 23. 10. Added current consumption in Chapter 6.4. 11. Updated RF output power in Chapter 6.5. 12. Added RF receiving sensitivity in Chapter 6.6.
1.2	2016-11-04	Lyndon LIU/ Michael ZHANG	<ol style="list-style-type: none"> 1. Added SGMII and WLAN interfaces in Table 2. 2. Updated function diagram in Figure 1. 3. Updated pin assignment (Top View) in Figure 2. 4. Added description of SGMII and WLAN interfaces in Table 4. 5. Added SGMII interface in Chapter 3.17. 6. Added WLAN interface in Chapter 3.18. 7. Added USB_BOOT interface in Chapter 3.19. 8. Added reference design of RF layout in Chapter 5.1.4. 9. Added note about SIMO in Chapter 6.6.

1.3	2017-01-24	Lyndon LIU/ Frank WANG	<ol style="list-style-type: none"> 1. Updated function diagram in Figure 1. 2. Updated pin assignment (top view) in Figure 2. 3. Added BT interface in Chapter 3.18.2. 4. Updated GNSS performance in Table 24. 5. Updated reference circuit of wireless connectivity interfaces with FC20 module in Figure 29. 6. Updated current consumption of EC25-E module in Table 33. 7. Updated EC25-A conducted RF receiving sensitivity in Table 38. 8. Added EC25-J conducted RF receiving sensitivity in Table 40.
1.4	2018-03-05	AnniceZHANG/ Lyndon LIU/ Frank WANG	<ol style="list-style-type: none"> 1. Updated functional diagram in Figure 1. 2. Updated LTE, UMTS and GSM features in Table 2. 3. Updated description of pin 40/136/137/138. 4. Updated PWRKEY pulled down time to 500 ms in Chapter 3.7.1 and reference circuit in Figure 10. 5. Updated reference circuit of (U)SIM interface in Figure 17 & 18. 6. Updated reference circuit of USB interface in Figure 19. 7. Updated PCM mode in Chapter 3.12. 8. Added SD card interface in Chapter 3.13. 9. Updated USB_BOOT reference circuit in Chapter 3.20. 10. Updated module operating frequencies in Table 26. 11. Updated antenna requirements in Table 30. 12. Updated EC25 series module current consumption in Chapter 6.4. 13. Updated EC25 series module conducted RF receiving sensitivity in Chapter 6.6. 14. Added thermal consideration description in Chapter 6.8. 15. Added dimension tolerance information in Chapter 7. 16. Added storage temperature range in Table 2 and Chapter 6.3. 17. Updated RF output power in Table 41. 18. Updated GPRS multi-slot classes in Table 53. 19. Updated storage information in Chapter 8.1.
1.5	2018-04-20	Kinsey ZHANG	<ol style="list-style-type: none"> 1. Added information of EC25-AF in Table 1. 2. Updated module operating frequencies in Table 27. 3. Added current consumption of EC25-AF module in Table 40. 4. Changed GNSS current consumption of EC25 series

			module into Table 41.
			5. Added EC25-AF conducted RF receiving sensitivity in Table 50.
			1. Added new variants EC25-EU/-EC/-EUX/-MX and related information.
			2. Updated functional diagram in Figure 1.
			3. Updated star structure of the power supply in Figure 8.
			4. Updated power-on scenario of module in Figure 12.
			5. Updated reference circuit with translator chip in Figure 20.
			6. Added timing sequence for entering into emergency download mode of USB_BOOT interface in Figure 32.
			7. Updated general description in Table 1.
			8. Updated module operating frequencies in Table 27.
			9. Updated GNSS frequency in Table 29.
			10. Updated antenna requirements in Table 30.
			11. Updated EC25-V current consumption in Table 36.
			12. Added EC25-EU current consumption in Table 41
			13. Added EC25 EC current consumption in Table 42.
			14. Added EC25-EUX current consumption in Table 43.
			15. Added EC25-MX current consumption in Table 44.
2.0	2019-04-30	Nathan LIU/ Frank WANG/ Ward WANG/ Ethan SHAN	16. Updated EC25-E conducted RF receiving sensitivity in Table 47.
			17. Updated EC25-A conducted RF receiving sensitivity in Table 48.
			18. Updated EC25-V conducted RF receiving sensitivity in Table 49.
			19. Updated EC25-AUT conducted RF receiving sensitivity in Table 52.
			20. Updated EC25-AUTL conducted RF receiving sensitivity in Table 53.
			21. Added EC25-EU conducted RF receiving sensitivity in Table 55.
			22. Added EC25 EC conducted RF receiving sensitivity in Table 56.
			23. Added EC25-EUX conducted RF receiving sensitivity in Table 57.
			24. Added EC25-MX conducted RF receiving sensitivity in Table 58.
			25. Updated recommended stencil thickness as 0.18–0.20 mm and reflow soldering thermal profile in Chapter 8.2.

2.1	2019-07-05	Fanny CHEN/ Ethan SHAN	<ol style="list-style-type: none"> 1. Added new variants EC25-AFX/-AUX and related information. 2. Added notes for interfaces not supported by ThreadX modules. 3. Updated supported protocols and USB serial drivers in Table 2. 4. Updated reference circuit of wireless connectivity interfaces with FC20 module in Figure 26. 5. Added EC25-AFX current consumption in Table 41. 6. Added EC25-AFX conducted RF receiving sensitivity in Table 56. 7. Updated mechanical dimensions of the module in Figure 45. 8. Added tape and reel directions in Figure 51.
2.2	2019-08-19	Ward WANG/ Owen WEI/ Frank WANG	<ol style="list-style-type: none"> 1. Updated EC25-J current consumption in Table 37. 2. Deleted the LTE-TDD bands information of EC25-AUT current consumption in Table 39. 3. Updated EC25-EC current consumption in Table 43. 4. Updated EC25-EUX current consumption in Table 44. 5. Added EC25-AUX current consumption in Table 46. 6. Updated EC25-AU conducted RF receiving sensitivity in Table 53. 7. Updated EC25-EU conducted RF receiving sensitivity in Table 58. 8. Added EC25-AUX conducted RF receiving sensitivity in Table 62.
2.3	2019-11-26	Fanny CHEN	<ol style="list-style-type: none"> 1. Removed related information of ThreadX OS because the baseline has been updated. 2. Updated the supported protocols and USB serial drivers in Table 2. 3. AT command AT+QCFG="airplanecontrol" has been fully developed in Chapter 3.5. 4. Updated the notes for GNSS performance in Chapter 4.2. 5. Updated the AT command be used to disable the receive diversity in Chapter 5.1.3. 6. Updated EC25-J current consumption in Table 37.
2.4.0	2020-05-24	Owen WEI	<ol style="list-style-type: none"> 1. Updated EC25-EUX conducted RF receiving sensitivity in Table 58. 2. Updated the storage and manufacturing information in Chapter 8. 3. Deleted related information of EC25-EC.
2.4.1	2020-12-23	Barret XIONG/ Cody ZHOU	<ol style="list-style-type: none"> 1. Added related information of EC25-T. 2. Added related information of EC25-EX.

2.4.2	2021-04-08	Barret XIONG/ Ailsa WANG	Added related information of EC25-JL. Added related information of EC25-AFDL.
-------	------------	-----------------------------	--

Contents

About the Document	3
Contents	8
Table Index	11
Figure Index	13
1 Introduction	15
1.1. Safety Information	1746
2 Product Concept	1917
2.1. General Description	1917
2.2. Key Features	2119
2.3. Functional Diagram	2324
2.4. Evaluation Board	2422
3 Application Interfaces	2523
3.1. General Description	2523
3.2. Pin Assignment	2523
3.3. Pin Description	2725
3.4. Operating Modes	3937
3.5. Power Saving	3937
3.5.1. Sleep Mode	3937
3.5.1.1. UART Application	3937
3.5.1.2. USB Application with USB Remote Wakeup Function	4038
3.5.1.3. USB Application with USB Suspend/Resume and RI Function	4139
3.5.1.4. USB Application without USB Suspend Function	4139
3.5.2. Airplane Mode	4240
3.6. Power Supply	4341
3.6.1. Power Supply Pins	4341
3.6.2. Decrease Voltage Drop	4341
3.6.3. Reference Design for Power Supply	4442
3.6.4. Monitor the Power Supply	4543
3.7. Power-on/off Scenarios	4543
3.7.1. Turn on Module Using the PWRKEY	4543
3.7.2. Turn off Module	4745
3.7.2.1. Turn off Module Using the PWRKEY Pin	4846
3.7.2.2. Turn off Module Using AT Command	4846
3.8. Reset Module	4846
3.9. (U)SIM Interface	5048
3.10. USB Interface	5250
3.11. UART Interfaces	5351
3.12. PCM and I2C Interfaces	5654

3.13.	SD Card Interface	5856
3.14.	Wireless Connectivity Interfaces	6058
3.14.1.	WLAN Interface	6260
3.14.2.	BT Interface	6364
3.15.	ADC Interfaces	6364
3.16.	SGMII Interface	6462
3.17.	Network Status Indication	6664
3.18.	STATUS	6866
3.19.	Behaviors of RI	6866
3.20.	USB_BOOT Interface	6967
4	GNSS Receiver	7169
4.1.	General Description	7169
4.2.	GNSS Performance	7169
4.3.	Layout Guidelines	7270
5	Antenna Interfaces	7374
5.1.	Main/Rx-diversity Antenna Interfaces	7374
5.1.1.	Pin Definition	7374
5.1.2.	Operating Frequency	7374
5.1.3.	Reference Design of RF Antenna Interface	7573
5.1.4.	Reference Design of RF Layout	7573
5.2.	GNSS Antenna Interface	7775
5.3.	Antenna Installation	7977
5.3.1.	Antenna Requirement	7977
5.3.2.	Recommended RF Connector for Antenna Installation	7977
6	Electrical, Reliability and Radio Characteristics	8280
6.1.	Absolute Maximum Ratings	8280
6.2.	Power Supply Ratings	8384
6.3.	Operating and Storage Temperatures	8384
6.4.	Current Consumption	8482
6.5.	RF Output Power	109407
6.6.	RF Receiving Sensitivity	110408
6.7.	Electrostatic Discharge	119416
6.8.	Thermal Consideration	119417
7	Mechanical Dimensions	122419
7.1.	Mechanical Dimensions of the Module	122419
7.2.	Recommended Footprint	123420
7.3.	Design Effect Drawings of the Module	125422
8	Storage, Manufacturing and Packaging	126423
8.1.	Storage	126423
8.2.	Manufacturing and Soldering	127424
8.3.	Packaging	128425

9	Appendix A References.....	130127
10	Appendix B GPRS Coding Schemes	134131
11	Appendix C GPRS Multi-slot Classes.....	135132
12	Appendix D EDGE Modulation and Coding Schemes	137134

Table Index

Table 1: Supported Frequency Bands and GNSS Function of EC25 Series Module	1947
Table 2: Key Features of EC25 Series Module	2149
Table 3: I/O Parameters Definition	2725
Table 4: Pin Description	2725
Table 5: Overview of Operating Modes	3937
Table 6: VBAT and GND Pins	4344
Table 7: Pin Definition of PWRKEY	4543
Table 8: Pin Definition of RESET_N	4947
Table 9: Pin Definition of (U)SIM Interface	5048
Table 10: Pin Description of USB Interface	5250
Table 11: Pin Definition of Main UART Interface	5452
Table 12: Pin Definition of Debug UART Interface	5452
Table 13: Logic Levels of Digital I/O	5452
Table 14: Pin Definition of PCM and I2C Interfaces	5755
Table 15: Pin Definition of SD Card Interface	5856
Table 16: Pin Definition of Wireless Connectivity Interfaces	6058
Table 17: Pin Definition of ADC Interfaces	6364
Table 18: Characteristic of ADC	6462
Table 19: Pin Definition of SGMII Interface	6462
Table 20: Pin Definition of Network Connection Status/Activity Indicator	6765
Table 21: Working State of Network Connection Status/Activity Indicator	6765
Table 22: Pin Definition of STATUS	6866
Table 23: Behaviors of RI	6967
Table 24: Pin Definition of USB_BOOT Interface	6967
Table 25: GNSS Performance	7169
Table 26: Pin Definition of RF Antennas	7374
Table 27: Module Operating Frequencies	7374
Table 28: Pin Definition of GNSS Antenna Interface	7775
Table 29: GNSS Frequency	7876
Table 30: Antenna Requirements	7977
Table 31: Absolute Maximum Ratings	8280
Table 32: Power Supply Ratings	8384
Table 33: Operating and Storage Temperatures	8384
Table 34: EC25-E Current Consumption	8482
Table 35: EC25-EX Current Consumption	8684
Table 36: EC25-A Current Consumption	8886
Table 37: EC25-V Current Consumption	8987
Table 38: EC25-J Current Consumption	9088
Table 39: EC25-JL Current Consumption	9189
Table 40: EC25-AU Current Consumption	9290
Table 41: EC25-AUT Current Consumption	9593

Table 42: EC25-AF Current Consumption.....	9694
Table 43: EC25-AFX Current Consumption	9795
Table 44: EC25-EU Current Consumption	9997
Table 45: EC25-EUX Current Consumption.....	10199
Table 46: EC25-MX Current Consumption.....	103404
Table 47: EC25-AUX Current Consumption.....	104402
Table 48: EC25-T Current Consumption	107405
Table 42: EC25-AFDL Current Consumption.....	108406
Table 49: GNSS Current Consumption of EC25 Series Module.....	109407
Table 50: RF Output Power.....	109407
Table 51: EC25-E Conducted RF Receiving Sensitivity.....	110408
Table 52: EC25-A Conducted RF Receiving Sensitivity.....	111409
Table 53: EC25-V Conducted RF Receiving Sensitivity.....	111409
Table 54: EC25-J Conducted RF Receiving Sensitivity	111409
Table 55: EC25-JL Conducted RF Receiving Sensitivity	112410
Table 56: EC25-AU Conducted RF Receiving Sensitivity	112410
Table 57: EC25-AUT Conducted RF Receiving Sensitivity.....	113411
Table 58: EC25-AUTL Conducted RF Receiving Sensitivity.....	113411
Table 59: EC25-AF Conducted RF Receiving Sensitivity	114412
Table 60: EC25-AFX Conducted RF Receiving Sensitivity	114412
Table 61: EC25-EU Conducted RF Receiving Sensitivity	115413
Table 62: EC25-EUX Conducted RF Receiving Sensitivity	115413
Table 63: EC25-MX Conducted RF Receiving Sensitivity.....	116414
Table 64: EC25-AUX Conducted RF Receiving Sensitivity	116414
Table 65: EC25-EX Conducted RF Receiving Sensitivity	117415
Table 66: EC25-T Conducted RF Receiving Sensitivity.....	118416
Table 67: Electrostatics Discharge Characteristics (25 °C, 45% Relative Humidity).....	119417
Table 68: Recommended Thermal Profile Parameters	128425
Table 69: Related Documents	130427
Table 70: Terms and Abbreviations.....	130427
Table 71: Description of Different Coding Schemes	134434
Table 72: GPRS Multi-slot Classes	135432
Table 73: EDGE Modulation and Coding Schemes	137434

Figure Index

Figure 1: Functional Diagram	2422
Figure 2: Pin Assignment (Top View)	2624
Figure 3: Sleep Mode Application via UART	4038
Figure 4: Sleep Mode Application with USB Remote Wakeup	4038
Figure 5: Sleep Mode Application with RI	4139
Figure 6: Sleep Mode Application without Suspend Function	4240
Figure 7: Power Supply Limits during Burst Transmission	4341
Figure 8: Star Structure of the Power Supply	4442
Figure 9: Reference Circuit of Power Supply	4543
Figure 10: Turn on the Module by Using Driving Circuit	4644
Figure 11: Turn on the Module by Using Keystroke	4644
Figure 12: Timing of Turning on Module	4745
Figure 13: Timing of Turning off Module	4846
Figure 14: Reference Circuit of RESET_N by Using Driving Circuit	4947
Figure 15: Reference Circuit of RESET_N by Using Button	4947
Figure 16: Timing of Resetting Module	5048
Figure 17: Reference Circuit of (U)SIM Interface with an 8-pin (U)SIM Card Connector	5149
Figure 18: Reference Circuit of (U)SIM Interface with a 6-pin (U)SIM Card Connector	5149
Figure 19: Reference Circuit of USB Application	5351
Figure 20: Reference Circuit with Translator Chip	5553
Figure 21: Reference Circuit with Transistor Circuit	5553
Figure 22: Primary Mode Timing	5654
Figure 23: Auxiliary Mode Timing	5755
Figure 24: Reference Circuit of PCM and I2C Application with Audio Codec	5856
Figure 25: Reference Circuit of SD Card Interface	5957
Figure 26: Reference Circuit of Wireless Connectivity Interfaces with FC20 Module	6260
Figure 27: Simplified Block Diagram for Ethernet Application	6563
Figure 28: Reference Circuit of SGMII Interface with PHY AR8033 Application	6664
Figure 29: Reference Circuit of the Network Indicator	6765
Figure 30: Reference Circuits of STATUS	6866
Figure 31: Reference Circuit of USB_BOOT Interface	7068
Figure 32: Timing Sequence for Entering Emergency Download Mode	7068
Figure 33: Reference Circuit of RF Antenna Interface	7573
Figure 34: Microstrip Design on a 2-layer PCB	7674
Figure 35: Coplanar Waveguide Design on a 2-layer PCB	7674
Figure 36: Coplanar Waveguide Design on a 4-layer PCB (Layer 3 as Reference Ground)	7674
Figure 37: Coplanar Waveguide Design on a 4-layer PCB (Layer 4 as Reference Ground)	7775
Figure 38: Reference Circuit of GNSS Antenna	7876
Figure 39: Dimensions of the U.FL-R-SMT Connector (Unit: mm)	8078
Figure 40: Mechanicals of U.FL-LP Connectors	8078
Figure 41: Space Factor of Mated Connector (Unit: mm)	8179

Figure 42: Referenced Heatsink Design (Heatsink at the Top of the Module)	120418
Figure 43: Referenced Heatsink Design (Heatsink at the Backside of Customers' PCB)	120418
Figure 44: Module Top and Side Dimensions	122419
Figure 45: Module Bottom Dimensions (Bottom View).....	123420
Figure 46: Recommended Footprint (Top View)	124421
Figure 47: Top View of the Module.....	125422
Figure 48: Bottom View of the Module	125422
Figure 49: Reflow Soldering Thermal Profile.....	127424
Figure 50: Tape Specifications	128425
Figure 51: Reel Specifications.....	129426
Figure 52: Tape and Reel Directions	129426

1 Introduction

This document defines EC25 series module and describes its air interface and hardware interfaces which are connected with customers' applications.

This document can help customers quickly understand module interface specifications, electrical and mechanical details, as well as other related information of EC25 series module. To facilitate its application in different fields, relevant reference design is also provided for customers' reference. Associated with application note and user guide, customers can use EC25 series module to design and set up mobile applications easily.

FCC Certification Requirements.

According to the definition of mobile and fixed device is described in Part 2.1091(b), this device is a mobile device.

And the following conditions must be met:

1. This Modular Approval is limited to OEM installation for mobile and fixed applications only. The antenna installation and operating configurations of this transmitter, including any applicable source-based timeaveraging duty factor, antenna gain and cable loss must satisfy MPE categorical Exclusion Requirements of 2.1091.

2. The EUT is a mobile device; maintain at least a 20 cm separation between the EUT and the user's body and must not transmit simultaneously with any other antenna or transmitter.

3. A label with the following statements must be attached to the host end product: This device contains

FCC ID: XMR2021EC25AFDL

4. To comply with FCC regulations limiting both maximum RF output power and human exposure to RF radiation, maximum antenna gain (including cable loss) must not exceed:

- LTE Band 2 : $\leq 8.000\text{dBi}$
- LTE Band 4: $\leq 8.000\text{dBi}$
- LTE Band 5 : $\leq 6.00\text{dBi}$
- LTE Band 12 : $\leq 5.004\text{dBi}$
- LTE Band 13: $\leq 5.00\text{dBi}$
- LTE Band 14: $\leq 5.00\text{dBi}$
- LTE Band 26: $\leq 8.00\text{dBi}$
- LTE Band 71: $\leq 5.00\text{dBi}$

5. This module must not transmit simultaneously with any other antenna or transmitter

6. The host end product must include a user manual that clearly defines operating requirements and conditions that must be observed to ensure compliance with current FCC RF exposure guidelines.

For portable devices, in addition to the conditions 3 through 6 described above, a separate approval is required to satisfy the SAR requirements of FCC Part 2.1093

If the device is used for other equipment that separate approval is required for all other operating

configurations, including portable configurations with respect to 2.1093 and different antenna configurations.

For this device, OEM integrators must be provided with labeling instructions of finished products. Please refer to KDB784748 D01 v07, section 8. Page 6/7 last two paragraphs:

A certified modular has the option to use a permanently affixed label, or an electronic label. For a permanently affixed label, the module must be labeled with an FCC ID - Section 2.926 (see 2.2 Certification (labeling requirements) above). The OEM manual must provide clear instructions explaining to the OEM the labeling requirements, options and OEM user manual instructions that are required (see next paragraph).

For a host using a certified modular with a standard fixed label, if (1) the module's FCC ID is not visible when installed in the host, or (2) if the host is marketed so that end users do not have straightforward commonly used methods for access to remove the module so that the FCC ID of the module is visible; then an additional permanent label referring to the enclosed module: **"Contains Transmitter Module FCC ID: XMR2021EC25AFDL"** or **"Contains FCC ID: XMR2021EC25AFDL"** must be used. The host OEM user manual must also contain clear instructions on how end users can find and/or access the module and the FCC ID.

The final host / module combination may also need to be evaluated against the FCC Part 15B criteria for unintentional radiators in order to be properly authorized for operation as a Part 15 digital device.

The user's manual or instruction manual for an intentional or unintentional radiator shall caution the user that changes or modifications not expressly approved by the party responsible for compliance could void the user's authority to operate the equipment. In cases where the manual is provided only in a form other than paper, such as on a computer disk or over the Internet, the information required by this section may be included in the manual in that alternative form, provided the user can reasonably be expected to have the capability to access information in that form.

This device complies with part 15 of the FCC Rules. Operation is subject to the following two conditions: (1) This device may not cause harmful interference, and (2) this device must accept any interference received, including interference that may cause undesired operation.

Changes or modifications not expressly approved by the manufacturer could void the user's authority to operate the equipment.

To ensure compliance with all non-transmitter functions the host manufacturer is responsible for ensuring compliance with the module(s) installed and fully operational. For example, if a host was previously authorized as an unintentional radiator under the Supplier's Declaration of Conformity procedure without a transmitter certified module and a module is added, the host manufacturer is responsible for ensuring that after the module is installed and operational the host continues to be compliant with the Part 15B unintentional radiator requirements.

Manual Information To the End User

The OEM integrator has to be aware not to provide information to the end user regarding how to install or remove this RF module in the user's manual of the end product which integrates this module. The end user manual shall include all required regulatory information/warning as show in this manual.

IC Statement

IRSS-GEN

"This device complies with Industry Canada's licence-exempt RSSs. Operation is subject to the following two conditions: (1) This device may not cause interference; and (2) This device must accept any interference, including interference that may cause undesired operation of the device." or "Le présent

appareil est conforme aux CNR d'Industrie Canada applicables aux appareils radio exempts de licence. L'exploitation est autorisée aux deux conditions suivantes :

1) l'appareil ne doit pas produire de brouillage; 2) l'utilisateur de l'appareil doit accepter tout brouillage radioélectrique subi, même si le brouillage est susceptible d'en compromettre le fonctionnement."

Déclaration sur l'exposition aux rayonnements RF

L'autre utilisé pour l'émetteur doit être installé pour fournir une distance de séparation d'au moins 20 cm de toutes les personnes et ne doit pas être colocalisé ou fonctionner conjointement avec une autre antenne ou un autre émetteur.

The host product shall be properly labeled to identify the modules within the host product.

The Innovation, Science and Economic Development Canada certification label of a module shall be clearly visible at all times when installed in the host product; otherwise, the host product must be labeled to display the Innovation, Science and Economic Development Canada certification number for the module, preceded by the word "Contains" or similar wording expressing the same meaning, as follows:

"Contains IC: 10224A- 21EC25AFDL" or "where: 10224A- 21EC25AFDL is the module's certification number".

Le produit hôte doit être correctement étiqueté pour identifier les modules dans le produit hôte.

L'étiquette de certification d'Innovation, Sciences et Développement économique Canada d'un module doit être clairement visible en tout temps lorsqu'il est installé dans le produit hôte; sinon, le produit hôte doit porter une étiquette indiquant le numéro de certification d'Innovation, Sciences et Développement économique Canada pour le module, précédé du mot «Contient» ou d'un libellé semblable exprimant la même signification, comme suit:

"Contient IC: 10224A- 21EC25AFDL" ou "où: 10224A- 21EC25AFDL est le numéro de certification du module".

- LTE Band 2 : $\leq 8.500\text{dBi}$
- LTE Band 4: $\leq 5.500\text{dBi}$
- LTE Band 5 : $\leq 6.64\text{dBi}$
- LTE Band 12 : $\leq 6.15\text{dBi}$
- LTE Band 13: $\leq 6.44\text{ dBi}$
- LTE Band 25: $\leq 8.000\text{dBi}$
- LTE Band 26: $\leq 6.06\text{dBi}$

1.1. Safety Information

The following safety precautions must be observed during all phases of operation, such as usage, service or repair of any cellular terminal or mobile incorporating EC25 series module. Manufacturers of the cellular terminal should send the following safety information to users and operating personnel, and incorporate these guidelines into all manuals supplied with the product. If not so, Quectel assumes no liability for customers' failure to comply with these precautions.



Full attention must be given to driving at all times in order to reduce the risk of an accident. Using a mobile while driving (even with a handsfree kit) causes distraction and can lead to an accident. Please comply with laws and regulations restricting the use of wireless devices while driving.



Switch off the cellular terminal or mobile before boarding an aircraft. The operation of wireless appliances in an aircraft is forbidden to prevent interference with communication systems. If the device offers an Airplane Mode, then it should be enabled prior to boarding an aircraft. Please consult the airline staff for more restrictions on the use of wireless devices on boarding the aircraft.



Wireless devices may cause interference on sensitive medical equipment, so please be aware of the restrictions on the use of wireless devices when in hospitals, clinics or other healthcare facilities.



Cellular terminals or mobiles operating over radio signals and cellular network cannot be guaranteed to connect in all possible conditions (for example, with unpaid bills or with an invalid (U)SIM card). When emergent help is needed in such conditions, please remember using emergency call. In order to make or receive a call, the cellular terminal or mobile must be switched on in a service area with adequate cellular signal strength.



The cellular terminal or mobile contains a transmitter and receiver. When it is ON, it receives and transmits radio frequency signals. RF interference can occur if it is used close to TV set, radio, computer or other electric equipment.



In locations with potentially explosive atmospheres, obey all posted signs to turn off wireless devices such as your phone or other cellular terminals. Areas with potentially explosive atmospheres include fuelling areas, below decks on boats, fuel or chemical transfer or storage facilities, areas where the air contains chemicals or particles such as grain, dust or metal powders, etc.

2 Product Concept

2.1. General Description

EC25 module is a series of LTE-FDD/LTE-TDD/WCDMA/GSM wireless communication module with receive diversity. It provides data connectivity on LTE-FDD, LTE-TDD, DC-HSDPA, HSPA+, HSDPA, HSUPA, WCDMA, EDGE and GPRS networks. It also provides GNSS¹⁾ and voice functionality²⁾ for customers' specific applications. EC25 series contain 14 variants: EC25-E, EC25-A, EC25-V, EC25-J, EC25-JL, EC25-AU, EC25-AUX, EC25-AUT, EC25-AF, EC25-AFX, EC25-EU, EC25-EUX, EC25-AUTL and EC25-MX. Customers can choose a dedicated type based on the region or operator. The following table shows the frequency bands of EC25 series module.

Table 1: Supported Frequency Bands and GNSS Function of EC25 Series Module

Modules ²⁾	LTE Bands	WCDMA Bands	GSM Bands	Rx-diversity	GNSS ¹⁾
EC25-E	FDD: B1/B3/B5/B7/B8/B20 TDD: B38/B40/B41	B1/B5/B8	900/1800 MHz	Y	
EC25-A	FDD: B2/B4/B12	B2/B4/B5	N	Y	
EC25-V	FDD: B4/B13	N	N	Y	
EC25-J	FDD: B1/B3/B8/B18/B19/ B26 TDD: B41	B1/B6/B8/ B19	N	Y	GPS, GLONASS, BeiDou/ Compass, Galileo, QZSS
EC25-JL	FDD: B1/B3/B8/B18/B19/ B26 TDD: B41	N	N	Y	
EC25-AU³⁾	FDD: B1/B2/B3/B4/B5/B7/ B8/B28 TDD: B40	B1/B2/B5/B8	850/900/ 1800/1900 MHz	Y	
EC25-AUX	FDD: B1/B2 ³⁾ /B3/B4/B5/ B7/B8/B28 TDD: B40	B1/B2/B4/B5/ B8	850/900/ 1800/1900 MHz	Y	
EC25-AUT	FDD: B1/B3/B5/B7/B28	B1/B5	N	Y	

EC25-AF	FDD: B2/B4/B5/B12/B13/ B14/B66/B71	B2/B4/B5	N	Y	
EC25-AFX	FDD: B2/B4/B5/B12/B13/ B14/B66/B71	B2/B4/B5	N	Y	
EC25-EU	FDD: B1/B3/B7/B8/B20/ B28A TDD: B38/B40/B41	B1/B8	900/1800 MHz	Y	
EC25-EUX	FDD: B1/B3/B7/B8/B20/ B28A TDD: B38/B40/B41	B1/B8	900/1800 MHz	Y	
EC25-T	FDD: B2/B4/B5/B12/B66/B71	N	N	Y	
EC25-AUTL	FDD: B3/B7/B28	N	N	Y	N
EC25-MX	FDD: B2/B4//B5/B7/B28/ B66	B2/B4/B5	N	Y	N
EC25-EX	FDD: B1/B3/B5/B7/B8/B20 TDD: B38/B40/B41	B1/B5/B8	900/1800 MHz	N	N
EC25-AFDL	FDD: B2/B4/B5/B12/B13/ B14/B66/B71		N	Y	GPS, GLONASS, BeiDou/ Compass, Galileo, QZSS

NOTES

1. ¹⁾ GNSS function is optional.
2. ²⁾ EC25 series module contains **Telematics** version and **Data-only** version. **Telematics** version supports voice and data functions, while **Data-only** version only supports data function.
3. ³⁾ B2 band on EC25-AU and EC25-AUX modules do not support Rx-diversity.
4. Y = Supported. N = Not supported.

With a compact profile of 29.0 mm × 32.0 mm × 2.4 mm, EC25 series can meet almost all requirements for M2M applications such as automotive, metering, tracking system, security, router, wireless POS, mobile computing device, PDA phone, tablet PC, etc.

EC25 series are an SMD type module which can be embedded into applications through its 144-pin pads, including 80 LCC signal pads and 64 LGA pads.

2.2. Key Features

The following table describes the detailed features of EC25 series module.

Table 2: Key Features of EC25 Series Module

Features	Description
Power Supply	Supply voltage: 3.3–4.3 V Typical supply voltage: 3.8 V
Transmitting Power	Class 4 (33 dBm \pm 2 dB) for GSM850 Class 4 (33 dBm \pm 2 dB) for EGSM900 Class 1 (30 dBm \pm 2 dB) for DCS1800 Class 1 (30 dBm \pm 2 dB) for PCS1900 Class E2 (27 dBm \pm 3 dB) for GSM850 8-PSK Class E2 (27 dBm \pm 3 dB) for EGSM900 8-PSK Class E2 (26 dBm \pm 3 dB) for DCS1800 8-PSK Class E2 (26 dBm \pm 3 dB) for PCS1900 8-PSK Class 3 (24 dBm + 1/-3 dB) for WCDMA bands Class 3 (23 dBm \pm 2 dB) for LTE-FDD bands Class 3 (23 dBm \pm 2 dB) for LTE-TDD bands
LTE Features	Support up to non-CA Cat 4 FDD and TDD Support 1.4/3/5/10/15/20 MHz RF bandwidth Support MIMO in DL direction LTE-FDD: Max 150 Mbps (DL)/Max 50 Mbps (UL) LTE-TDD: Max 130 Mbps (DL)/Max 30 Mbps (UL)
UMTS Features	Support 3GPP R8 DC-HSDPA, HSPA+, HSDPA, HSUPA and WCDMA Support QPSK, 16-QAM and 64-QAM modulation DC-HSDPA: Max 42 Mbps (DL) HSUPA: Max 5.76 Mbps (UL) WCDMA: Max 384 kbps (DL)/Max 384 kbps (UL)
GSM Features	GPRS: Support GPRS multi-slot class 33 (33 by default) Coding scheme: CS-1, CS-2, CS-3 and CS-4 Max 107 kbps (DL)/Max 85.6 kbps (UL) EDGE: Support EDGE multi-slot class 33 (33 by default) Support GMSK and 8-PSK for different MCS (Modulation and Coding)

	<p>Scheme)</p> <p>Downlink coding schemes: MCS 1-9</p> <p>Uplink coding schemes: MCS 1-9</p> <p>Max 296 kbps (DL)/Max 236.8 kbps (UL)</p>
Internet Protocol Features	<p>Support TCP/UDP/PPP/FTP/FTPS/HTTP/HTTPS/NTP/PING/QMI/NITZ/SMTP/SSL/MQTT/FILE/CMUX/SMTSPS/MMS/FILE protocols</p> <p>Support PAP (Password Authentication Protocol) and CHAP (Challenge Handshake Authentication Protocol) protocols which are usually used for PPP connections</p>
SMS	<p>Text and PDU mode</p> <p>Point-to-point MO and MT</p> <p>SMS cell broadcast</p> <p>SMS storage: ME by default</p>
(U)SIM Interface	Support USIM/SIM card: 1.8 V, 3.0 V
Audio Features	<p>Support one digital audio interface: PCM interface</p> <p>GSM: HR/FR/EFR/AMR/AMR-WB</p> <p>WCDMA: AMR/AMR-WB</p> <p>LTE: AMR/AMR-WB</p> <p>Support echo cancellation and noise suppression</p>
PCM Interface	<p>Used for audio function with external codec</p> <p>Support 16-bit linear data format</p> <p>Support long frame synchronization and short frame synchronization</p> <p>Support master and slave modes, but must be the master in long frame synchronization</p>
USB Interface	<p>Compliant with USB 2.0 specification (slave only); the data transfer rate can reach up to 480 Mbps</p> <p>Used for AT command communication, data transmission, GNSS NMEA output, software debugging, firmware upgrade and voice over USB</p> <p>Support USB serial drivers for: Windows 7/8/8.1/10, Linux 2.6–5.4, Android 4.x–9.x, etc.</p>
UART Interfaces	<p>Main UART:</p> <p>Used for AT command communication and data transmission</p> <p>Baud rates reach up to 921600 bps, 115200 bps by default</p> <p>Support RTS and CTS hardware flow control</p> <p>Debug UART:</p> <p>Used for Linux console and log output</p> <p>115200 bps baud rate</p>
SD Card Interface	Support SD 3.0 protocol
SGMII Interface	<p>Support 10 Mbps/100 Mbps/1000 Mbps Ethernet work mode</p> <p>Support maximum 150 Mbps (DL)/50 Mbps (UL) for 4G network</p>
Wireless Connectivity Interfaces	Support a low-power SDIO 3.0 interface for WLAN and UART/PCM interfaces for Bluetooth

Rx-diversity	Support LTE/WCDMA Rx-diversity
GNSS Features	Gen8C Lite of Qualcomm Protocol: NMEA 0183 Data update rate: 1 Hz by default
AT Commands	Compliant with 3GPP TS 27.007, 27.005 and Quectel enhanced AT commands
Network Indication	Two pins including NET_MODE and NET_STATUS to indicate network connectivity status
Antenna Interfaces	Including main antenna interface (ANT_MAIN), Rx-diversity antenna interface (ANT_DIV) and GNSS antenna interface (ANT_GNSS)
Physical Characteristics	Size: (29.0 ±0.15) mm × (32.0 ±0.15) mm × (2.4 ±0.2) mm Weight: approx. 4.9 g
Temperature Range	Operating temperature range: -35 to +75 °C ¹⁾ Extended temperature range: -40 to +85 °C ²⁾ Storage temperature range: -40 to +90 °C
Firmware Upgrade	USB interface or DFOTA
RoHS	All hardware components are fully compliant with EU RoHS directive

NOTES

- ¹⁾ Within operating temperature range, the module is 3GPP compliant.
- ²⁾ Within extended temperature range, the module remains the ability to establish and maintain a voice, SMS, data transmission, etc. There is no unrecoverable malfunction. There are also no effects on radio spectrum and no harm to radio network. Only one or more parameters like P_{out} might reduce in their value and exceed the specified tolerances. When the temperature returns to normal operating temperature levels, the module will meet 3GPP specifications again.
- “*” means under development.

2.3. Functional Diagram

The following figure shows a block diagram of EC25 and illustrates the major functional parts.

- Power management
- Baseband
- DDR + NAND flash
- Radio frequency
- Peripheral interfaces

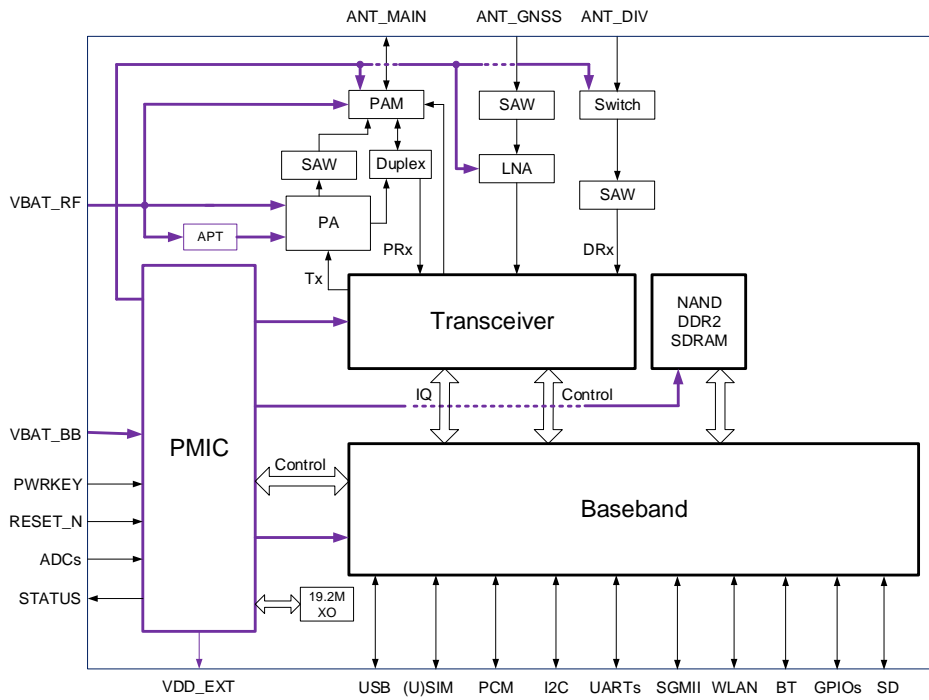

Figure 1: Functional Diagram

2.4. Evaluation Board

In order to help customers develop applications with EC25 series, Quectel supplies an evaluation board (UMTS & LTE EVB), USB to RS-232 converter cable, earphone, antenna and other peripherals to control or test the module. For more details, please refer to **document [8]**.

3 Application Interfaces

3.1. General Description

EC25 series are equipped with 80 LCC pads and 64 LGA pads that can be connected to cellular application platform. The subsequent chapters will provide detailed descriptions of the following interfaces/functions.

- Power supply
- (U)SIM interface
- USB interface
- UART interfaces
- PCM and I2C interfaces
- SD card interface
- ADC interfaces
- Status indication
- SGMII interface
- Wireless connectivity interfaces
- USB_BOOT interface

3.2. Pin Assignment

The following figure shows the pin assignment of EC25 series module.

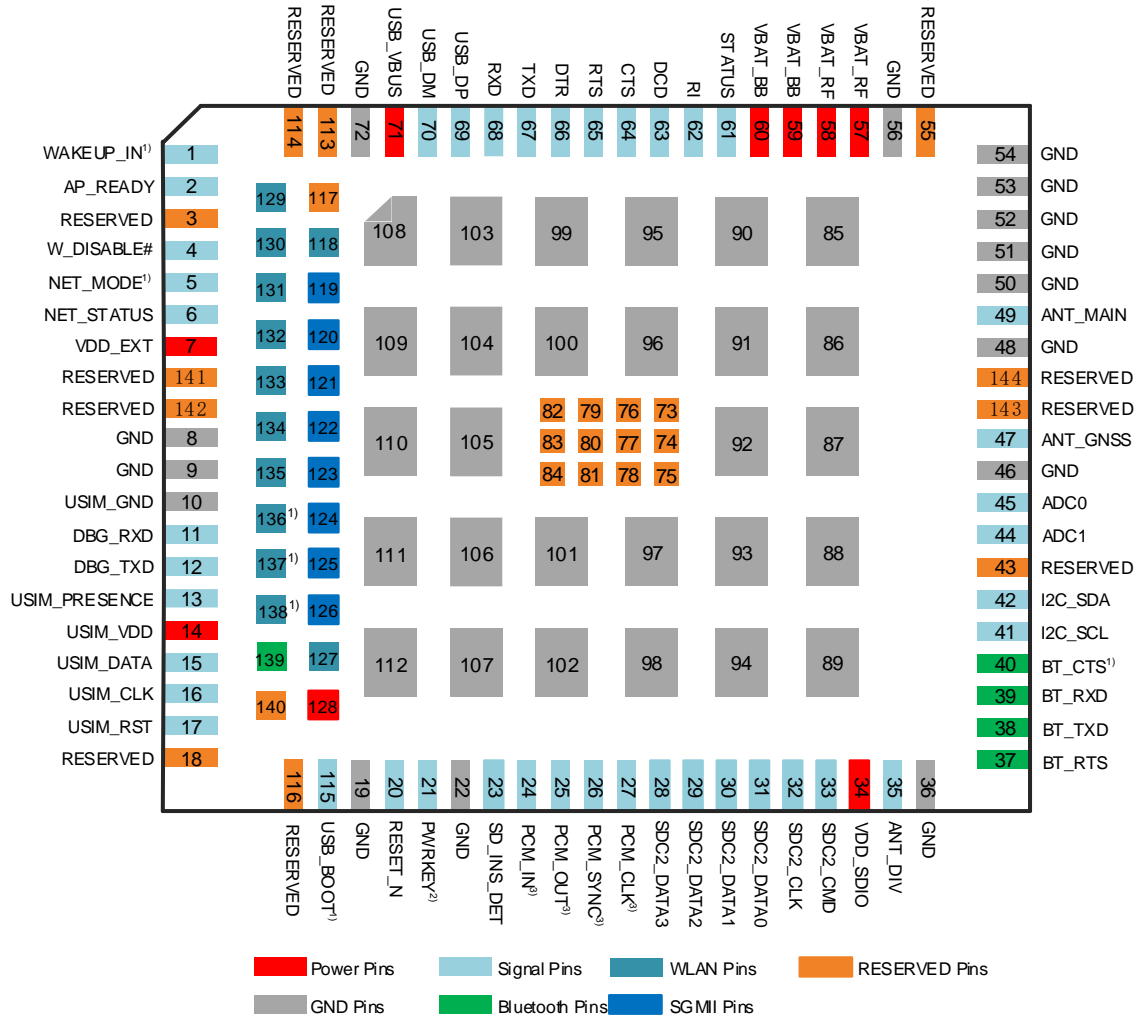

Figure 2: Pin Assignment (Top View)

NOTES

- ¹⁾ means pins WAKEUP_IN, NET_MODE, WLAN_EN, COEX_UART_RX, COEX_UART_TX, USB_BOOT and BT_CTS cannot be pulled up before startup.
- ²⁾ PWRKEY output voltage is 0.8 V because of the diode drop in the Qualcomm chipset.
- ³⁾ means digital audio (PCM) is only supported on **Telematics** version.
- Pins 37–40, 118, 127 and 129–139 are used for wireless connectivity interfaces, among which pins 118, 127 and 129–138 are WLAN function pins, and the rest are Bluetooth (BT) function pins. BT function is under development.
- Pins 119–126 and 128 are used for SGMII interface.
- Pins 24–27 for PCM function are used for audio design on EC25 series module and BT function on FC20 module.
- Keep all RESERVED pins and unused pins unconnected.
- GND pins 85–112 should be connected to ground in the design. RESERVED pins 73–84 should not

be designed in schematic and PCB decal, and these pins should be served as a keepout area.

3.3. Pin Description

The following tables show the pin definition of EC25 series module.

Table 3: I/O Parameters Definition

Type	Description
AI	Analog Input
AO	Analog Output
DI	Digital Input
DO	Digital Output
IO	Bidirectional
OD	Open Drain
PI	Power Input
PO	Power Output

Table 4: Pin Description

Power Supply					
Pin Name	Pin No.	I/O	Description	DC Characteristics	Comment
VBAT_BB	59, 60	PI	Power supply for module's baseband part	Vmax = 4.3 V Vmin = 3.3 V Vnorm = 3.8 V	It must be provided with sufficient current up to 0.8 A.
VBAT_RF	57, 58	PI	Power supply for module's RF part	Vmax = 4.3 V Vmin = 3.3 V Vnorm = 3.8 V	It must be provided with sufficient current up to 1.8 A in a burst transmission.
VDD_EXT	7	PO	Provide 1.8 V for external circuit	Vnorm = 1.8 V Iomax = 50 mA	Power supply for external GPIO's pull-up

circuits.
If unused, keep it open.

GND	8, 9, 19, 22, 36, 46, 48, 50–54, 56, 72, 85–112	Ground
-----	---	--------

Power-on/off

Pin Name	Pin No.	I/O	Description	DC Characteristics	Comment
PWRKEY	21	DI	Turn on/off the module	$V_H = 0.8\text{ V}$	The output voltage is 0.8 V because of the diode drop in the Qualcomm chipset.
RESET_N	20	DI	Reset signal of the module	$V_{IHmax} = 2.1\text{ V}$ $V_{IHmin} = 1.3\text{ V}$ $V_{ILmax} = 0.5\text{ V}$	If unused, keep it open.

Status Indication

Pin Name	Pin No.	I/O	Description	DC Characteristics	Comment
STATUS	61	OD	Indicate the module operating status	The drive current should be less than 0.9 mA.	An external pull-up resistor is required. If unused, keep it open.
NET_MODE	5	DO	Indicate the module's network registration mode	$V_{OHmin} = 1.35\text{ V}$ $V_{OLmax} = 0.45\text{ V}$	1.8 V power domain. It cannot be pulled up before startup. If unused, keep it open.
NET_STATUS	6	DO	Indicate the module's network activity status	$V_{OHmin} = 1.35\text{ V}$ $V_{OLmax} = 0.45\text{ V}$	1.8 V power domain. If unused, keep it open.

USB Interface

Pin Name	Pin No.	I/O	Description	DC Characteristics	Comment
USB_VBUS	71	PI	USB connection detection	$V_{max} = 5.25\text{ V}$ $V_{min} = 3.0\text{ V}$ $V_{norm} = 5.0\text{ V}$	Typical: 5.0 V. If unused, keep it open.
USB_DP	69	IO	USB differential data bus (+)		USB 2.0 Compliant. Require differential impedance of 90 Ω. If unused, keep it

					open.
USB_DM	70	IO	USB differential data bus (-)		USB 2.0 Compliant. Require differential impedance of 90 Ω. If unused, keep it open.

(U)SIM Interface

Pin Name	Pin No.	I/O	Description	DC Characteristics	Comment
USIM_GND	10		Specified ground for (U)SIM card		
USIM_PRESENCE	13	DI	(U)SIM card insertion detection	$V_{ILmin} = -0.3\text{ V}$ $V_{ILmax} = 0.6\text{ V}$ $V_{IHmin} = 1.2\text{ V}$ $V_{IHmax} = 2.0\text{ V}$ $I_{Omax} = 50\text{ mA}$	1.8 V power domain. If unused, keep it open.
USIM_VDD	14	PO	Power supply for (U)SIM card	For 1.8 V(U)SIM: $V_{max} = 1.9\text{ V}$ $V_{min} = 1.7\text{ V}$ For 3.0 V(U)SIM: $V_{max} = 3.05\text{ V}$ $V_{min} = 2.7\text{ V}$	Either 1.8 V or 3.0 V is supported by the module automatically.
USIM_DATA	15	IO	Data signal of (U)SIM card	For 1.8 V (U)SIM: $V_{ILmax} = 0.6\text{ V}$ $V_{IHmin} = 1.2\text{ V}$ $V_{OLmax} = 0.45\text{ V}$ $V_{OHmin} = 1.35\text{ V}$ For 3.0 V (U)SIM: $V_{ILmax} = 1.0\text{ V}$ $V_{IHmin} = 1.95\text{ V}$ $V_{OLmax} = 0.45\text{ V}$ $V_{OHmin} = 2.55\text{ V}$	
USIM_CLK	16	DO	Clock signal of (U)SIM card	For 1.8 V (U)SIM: $V_{OLmax} = 0.45\text{ V}$ $V_{OHmin} = 1.35\text{ V}$ For 3.0 V (U)SIM: $V_{OLmax} = 0.45\text{ V}$ $V_{OHmin} = 2.55\text{ V}$	

USIM_RST	17	DO	Reset signal of (U)SIM card	<p>For 1.8 V (U)SIM: $V_{OLmax} = 0.45\text{ V}$ $V_{OHmin} = 1.35\text{ V}$</p> <p>For 3.0 V (U)SIM: $V_{OLmax} = 0.45\text{ V}$ $V_{OHmin} = 2.55\text{ V}$</p>
----------	----	----	-----------------------------	---

Main UART Interface

Pin Name	Pin No.	I/O	Description	DC Characteristics	Comment
RI	62	DO	Ring indicator	$V_{OLmax} = 0.45\text{ V}$ $V_{OHmin} = 1.35\text{ V}$	1.8 V power domain. If unused, keep it open.
DCD	63	DO	Data carrier detection	$V_{OLmax} = 0.45\text{ V}$ $V_{OHmin} = 1.35\text{ V}$	1.8 V power domain. If unused, keep it open.
CTS	64	DO	Clear to send	$V_{OLmax} = 0.45\text{ V}$ $V_{OHmin} = 1.35\text{ V}$	1.8 V power domain. If unused, keep it open.
RTS	65	DI	Request to send	$V_{ILmin} = -0.3\text{ V}$ $V_{ILmax} = 0.6\text{ V}$ $V_{IHmin} = 1.2\text{ V}$ $V_{IHmax} = 2.0\text{ V}$	1.8 V power domain. If unused, keep it open.
DTR	66	DI	Data terminal ready, sleep mode control	$V_{ILmin} = -0.3\text{ V}$ $V_{ILmax} = 0.6\text{ V}$ $V_{IHmin} = 1.2\text{ V}$ $V_{IHmax} = 2.0\text{ V}$	1.8 V power domain. Pulled up by default. Low level wakes up the module. If unused, keep it open.
TXD	67	DO	Transmit data	$V_{OLmax} = 0.45\text{ V}$ $V_{OHmin} = 1.35\text{ V}$	1.8 V power domain. If unused, keep it open.
RXD	68	DI	Receive data	$V_{ILmin} = -0.3\text{ V}$ $V_{ILmax} = 0.6\text{ V}$ $V_{IHmin} = 1.2\text{ V}$ $V_{IHmax} = 2.0\text{ V}$	1.8 V power domain. If unused, keep it open.

Debug UART Interface

Pin Name	Pin No.	I/O	Description	DC Characteristics	Comment
DBG_TXD	12	DO	Transmit data	$V_{OLmax} = 0.45\text{ V}$ $V_{OHmin} = 1.35\text{ V}$	1.8 V power domain. If unused, keep it open.

DBG_RXD	11	DI	Receive data	$V_{ILmin} = -0.3\text{ V}$ $V_{ILmax} = 0.6\text{ V}$ $V_{IHmin} = 1.2\text{ V}$ $V_{IHmax} = 2.0\text{ V}$	1.8 V power domain. If unused, keep it open.
---------	----	----	--------------	---	---

ADC Interfaces

Pin Name	Pin No.	I/O	Description	DC Characteristics	Comment
ADC0	45	AI	General-purpose analog to digital converter	Voltage range: 0.3 V to VBAT_BB	If unused, keep it open.
ADC1	44	AI	General-purpose analog to digital converter	Voltage range: 0.3 V to VBAT_BB	If unused, keep it open.

PCM Interface¹⁾

Pin Name	Pin No.	I/O	Description	DC Characteristics	Comment
PCM_IN	24	DI	PCM data input	$V_{ILmin} = -0.3\text{ V}$ $V_{ILmax} = 0.6\text{ V}$ $V_{IHmin} = 1.2\text{ V}$ $V_{IHmax} = 2.0\text{ V}$	1.8 V power domain. If unused, keep it open.
PCM_OUT	25	DO	PCM data output	$V_{OLmax} = 0.45\text{ V}$ $V_{OHmin} = 1.35\text{ V}$	1.8 V power domain. If unused, keep it open.
PCM_SYNC	26	IO	PCM data frame synchronization signal	$V_{OLmax} = 0.45\text{ V}$ $V_{OHmin} = 1.35\text{ V}$ $V_{ILmin} = -0.3\text{ V}$ $V_{ILmax} = 0.6\text{ V}$ $V_{IHmin} = 1.2\text{ V}$ $V_{IHmax} = 2.0\text{ V}$	1.8 V power domain. In master mode, it is an output signal. In slave mode, it is an input signal. If unused, keep it open.
PCM_CLK	27	IO	PCM clock	$V_{OLmax} = 0.45\text{ V}$ $V_{OHmin} = 1.35\text{ V}$ $V_{ILmin} = -0.3\text{ V}$ $V_{ILmax} = 0.6\text{ V}$ $V_{IHmin} = 1.2\text{ V}$ $V_{IHmax} = 2.0\text{ V}$	1.8 V power domain. In master mode, it is an output signal. In slave mode, it is an input signal. If unused, keep it open.

I2C Interface

Pin Name	Pin No.	I/O	Description	DC Characteristics	Comment
I2C_SCL	41	OD	I2C serial clock. Used for external		An external 1.8 V pull-up resistor is

			codec.		required. If unused, keep it open.
I2C_SDA	42	OD	I2C serial data. Used for external codec.		An external 1.8 V pull-up resistor is required. If unused, keep it open.

SD Card Interface

Pin Name	Pin No.	I/O	Description	DC Characteristics	Comment
SDC2_DATA3	28	IO	SD card SDIO bus DATA3	1.8 V signaling: $V_{OLmax} = 0.45\text{ V}$ $V_{OHmin} = 1.4\text{ V}$ $V_{ILmin} = -0.3\text{ V}$ $V_{ILmax} = 0.58\text{ V}$ $V_{IHmin} = 1.27\text{ V}$ $V_{IHmax} = 2.0\text{ V}$ 3.0 V signaling: $V_{OLmax} = 0.38\text{ V}$ $V_{OHmin} = 2.01\text{ V}$ $V_{ILmin} = -0.3\text{ V}$ $V_{ILmax} = 0.76\text{ V}$ $V_{IHmin} = 1.72\text{ V}$ $V_{IHmax} = 3.34\text{ V}$	SDIO signal level can be selected according to SD card supported level, please refer to SD 3.0 protocol for more details. If unused, keep it open.
SDC2_DATA2	29	IO	SD card SDIO bus DATA2	1.8 V signaling: $V_{OLmax} = 0.45\text{ V}$ $V_{OHmin} = 1.4\text{ V}$ $V_{ILmin} = -0.3\text{ V}$ $V_{ILmax} = 0.58\text{ V}$ $V_{IHmin} = 1.27\text{ V}$ $V_{IHmax} = 2.0\text{ V}$ 3.0 V signaling: $V_{OLmax} = 0.38\text{ V}$ $V_{OHmin} = 2.01\text{ V}$ $V_{ILmin} = -0.3\text{ V}$ $V_{ILmax} = 0.76\text{ V}$ $V_{IHmin} = 1.72\text{ V}$ $V_{IHmax} = 3.34\text{ V}$	SDIO signal level can be selected according to SD card supported level, please refer to SD 3.0 protocol for more details. If unused, keep it open.
SDC2_DATA1	30	IO	SD card SDIO bus DATA1	1.8 V signaling: $V_{OLmax} = 0.45\text{ V}$	SDIO signal level can

				$V_{OHmin} = 1.4\text{ V}$ $V_{ILmin} = -0.3\text{ V}$ $V_{ILmax} = 0.58\text{ V}$ $V_{IHmin} = 1.27\text{ V}$ $V_{IHmax} = 2.0\text{ V}$ 3.0 V signaling: $V_{OLmax} = 0.38\text{ V}$ $V_{OHmin} = 2.01\text{ V}$ $V_{ILmin} = -0.3\text{ V}$ $V_{ILmax} = 0.76\text{ V}$ $V_{IHmin} = 1.72\text{ V}$ $V_{IHmax} = 3.34\text{ V}$	<p>be selected according to SD card supported level, please refer to SD 3.0 protocol for more details.</p> <p>If unused, keep it open.</p>
SDC2_DATA0	31	IO	SD card SDIO bus DATA0	1.8 V signaling: $V_{OLmax} = 0.45\text{ V}$ $V_{OHmin} = 1.4\text{ V}$ $V_{ILmin} = -0.3\text{ V}$ $V_{ILmax} = 0.58\text{ V}$ $V_{IHmin} = 1.27\text{ V}$ $V_{IHmax} = 2.0\text{ V}$ 3.0 V signaling: $V_{OLmax} = 0.38\text{ V}$ $V_{OHmin} = 2.01\text{ V}$ $V_{ILmin} = -0.3\text{ V}$ $V_{ILmax} = 0.76\text{ V}$ $V_{IHmin} = 1.72\text{ V}$ $V_{IHmax} = 3.34\text{ V}$	<p>SDIO signal level can be selected according to SD card supported level, please refer to SD 3.0 protocol for more details.</p> <p>If unused, keep it open.</p>
SDC2_CLK	32	DO	SD card SDIO bus clock	1.8 V signaling: $V_{OLmax} = 0.45\text{ V}$ $V_{OHmin} = 1.4\text{ V}$ 3.0 V signaling: $V_{OLmax} = 0.38\text{ V}$ $V_{OHmin} = 2.01\text{ V}$	<p>SDIO signal level can be selected according to SD card supported level, please refer to SD 3.0 protocol for more details.</p> <p>If unused, keep it open.</p>
SDC2_CMD	33	IO	SD card SDIO bus command	1.8V signaling: $V_{OLmax} = 0.45\text{ V}$ $V_{OHmin} = 1.4\text{ V}$ $V_{ILmin} = -0.3\text{ V}$ $V_{ILmax} = 0.58\text{ V}$ $V_{IHmin} = 1.27\text{ V}$ $V_{IHmax} = 2.0\text{ V}$	<p>SDIO signal level can be selected according to SD card supported level, please refer to SD 3.0 protocol for more details.</p> <p>If unused, keep it open.</p>

				3.0 V signaling: $V_{OLmax} = 0.38\text{ V}$ $V_{OHmin} = 2.01\text{ V}$ $V_{ILmin} = -0.3\text{ V}$ $V_{ILmax} = 0.76\text{ V}$ $V_{IHmin} = 1.72\text{ V}$ $V_{IHmax} = 3.34\text{ V}$	
SD_INS_DET	23	DI	SD card insertion detect	$V_{ILmin} = -0.3\text{ V}$ $V_{ILmax} = 0.6\text{ V}$ $V_{IHmin} = 1.2\text{ V}$ $V_{IHmax} = 2.0\text{ V}$	1.8 V power domain. If unused, keep it open.
VDD_SDIO	34	PO	SD card SDIO bus pull-up power	$I_{Omax} = 50\text{ mA}$	1.8/2.85 V configurable. Cannot be used for SD card power. If unused, keep it open.
SGMII Interface					
Pin Name	Pin No.	I/O	Description	DC Characteristics	Comment
EPHY_RST_N	119	DO	Ethernet PHY reset	For 1.8 V: $V_{OLmax} = 0.45\text{ V}$ $V_{OHmin} = 1.4\text{ V}$ For 2.85 V: $V_{OLmax} = 0.35\text{ V}$ $V_{OHmin} = 2.14\text{ V}$	1.8/2.85 V power domain. If unused, keep it open.
EPHY_INT_N	120	DI	Ethernet PHY interrupt	$V_{ILmin} = -0.3\text{ V}$ $V_{ILmax} = 0.6\text{ V}$ $V_{IHmin} = 1.2\text{ V}$ $V_{IHmax} = 2.0\text{ V}$	1.8 V power domain. If unused, keep it open.
SGMII_MDATA	121	IO	SGMII MDIO (Management Data Input/Output) data	For 1.8 V: $V_{OLmax} = 0.45\text{ V}$ $V_{OHmin} = 1.4\text{ V}$ $V_{ILmax} = 0.58\text{ V}$ $V_{IHmin} = 1.27\text{ V}$ For 2.85 V: $V_{OLmax} = 0.35\text{ V}$ $V_{OHmin} = 2.14\text{ V}$ $V_{ILmax} = 0.71\text{ V}$ $V_{IHmin} = 1.78\text{ V}$	1.8/2.85 V power domain. If unused, keep it open.

SGMII_MCLK	122	DO	SGMII MDIO (Management Data Input/Output) clock	<p>For 1.8 V: V_{OLmax} = 0.45 V V_{OHmin} = 1.4 V</p> <p>For 2.85 V: V_{OLmax} = 0.35 V V_{OHmin} = 2.14 V</p>	1.8/2.85 V power domain. If unused, keep it open.
SGMII_TX_M	123	AO	SGMII transmission - minus		Connect with a 0.1 μF capacitor, and is close to the PHY side. If unused, keep it open.
SGMII_TX_P	124	AO	SGMII transmission - plus		Connect with a 0.1 μF capacitor, and is close to the PHY side. If unused, keep it open.
SGMII_RX_P	125	AI	SGMII receiving - plus		Connect with a 0.1 μF capacitor, and is close to EC25 series module. If unused, keep it open.
SGMII_RX_M	126	AI	SGMII receiving - minus		Connect with a 0.1 μF capacitor, and is close to EC25 series module. If unused, keep it open.
USIM2_VDD	128	PO	SGMII MDIO pull-up power source		Configurable power source. 1.8/2.85 V power domain. If unused, keep it open.

Wireless Connectivity Interfaces

Pin Name	Pin No.	I/O	Description	DC Characteristics	Comment
SDC1_DATA3	129	IO	WLAN SDIO data bus D3	<p>V_{OLmax} = 0.45 V V_{OHmin} = 1.35 V V_{ILmin} = -0.3 V V_{ILmax} = 0.6 V V_{IHmin} = 1.2 V</p>	1.8 V power domain. If unused, keep it open.

				$V_{IHmax} = 2.0\text{ V}$	
SDC1_DATA2	130	IO	WLAN SDIO data bus D2	$V_{OLmax} = 0.45\text{ V}$ $V_{OHmin} = 1.35\text{ V}$ $V_{ILmin} = -0.3\text{ V}$ $V_{ILmax} = 0.6\text{ V}$ $V_{IHmin} = 1.2\text{ V}$ $V_{IHmax} = 2.0\text{ V}$	1.8 V power domain. If unused, keep it open.
SDC1_DATA1	131	IO	WLAN SDIO data bus D1	$V_{OLmax} = 0.45\text{ V}$ $V_{OHmin} = 1.35\text{ V}$ $V_{ILmin} = -0.3\text{ V}$ $V_{ILmax} = 0.6\text{ V}$ $V_{IHmin} = 1.2\text{ V}$ $V_{IHmax} = 2.0\text{ V}$	1.8 V power domain. If unused, keep it open.
SDC1_DATA0	132	IO	WLAN SDIO data bus D0	$V_{OLmax} = 0.45\text{ V}$ $V_{OHmin} = 1.35\text{ V}$ $V_{ILmin} = -0.3\text{ V}$ $V_{ILmax} = 0.6\text{ V}$ $V_{IHmin} = 1.2\text{ V}$ $V_{IHmax} = 2.0\text{ V}$	1.8 V power domain. If unused, keep it open.
SDC1_CLK	133	DO	WLAN SDIO bus clock	$V_{OLmax} = 0.45\text{ V}$ $V_{OHmin} = 1.35\text{ V}$	1.8 V power domain. If unused, keep it open.
SDC1_CMD	134	DO	WLAN SDIO bus command	$V_{OLmax} = 0.45\text{ V}$ $V_{OHmin} = 1.35\text{ V}$	1.8 V power domain. If unused, keep it open.
PM_ENABLE	127	DO	WLAN power control	$V_{OLmax} = 0.45\text{ V}$ $V_{OHmin} = 1.35\text{ V}$	1.8 V power domain. If unused, keep it open.
WAKE_ON_WIRELESS	135	DI	Wake up the host (EC25 series module) by FC20 module	$V_{ILmin} = -0.3\text{ V}$ $V_{ILmax} = 0.6\text{ V}$ $V_{IHmin} = 1.2\text{ V}$ $V_{IHmax} = 2.0\text{ V}$	1.8 V power domain. Active low. If unused, keep it open.
WLAN_EN	136	DO	WLAN function control via FC20 module	$V_{OLmax} = 0.45\text{ V}$ $V_{OHmin} = 1.35\text{ V}$	1.8 V power domain. Active high. Cannot be pulled up before startup. If unused, keep it open.
COEX_UART_RX	137	DI	LTE/WLAN & BT coexistence signal	$V_{ILmin} = -0.3\text{ V}$ $V_{ILmax} = 0.6\text{ V}$ $V_{IHmin} = 1.2\text{ V}$ $V_{IHmax} = 2.0\text{ V}$	1.8 V power domain. Cannot be pulled up before startup. If unused, keep it open.

COEX_UART_TX	138	DO	LTE/WLAN & BT coexistence signal	$V_{OLmax} = 0.45\text{ V}$ $V_{OHmin} = 1.35\text{ V}$	1.8 V power domain. Cannot be pulled up before startup. If unused, keep it open.
WLAN_SLP_CLK	118	DO	WLAN sleep clock		If unused, keep it open.
BT_RTS	37	DI	BT UART request to send	$V_{ILmin} = -0.3\text{ V}$ $V_{ILmax} = 0.6\text{ V}$ $V_{IHmin} = 1.2\text{ V}$ $V_{IHmax} = 2.0\text{ V}$	1.8 V power domain. If unused, keep it open.
BT_TXD	38	DO	BT UART transmit data	$V_{OLmax} = 0.45\text{ V}$ $V_{OHmin} = 1.35\text{ V}$	1.8 V power domain. If unused, keep it open.
BT_RXD	39	DI	BT UART receive data	$V_{ILmin} = -0.3\text{ V}$ $V_{ILmax} = 0.6\text{ V}$ $V_{IHmin} = 1.2\text{ V}$ $V_{IHmax} = 2.0\text{ V}$	1.8 V power domain. If unused, keep it open.
BT_CTS	40	DO	BT UART clear to send	$V_{OLmax} = 0.45\text{ V}$ $V_{OHmin} = 1.35\text{ V}$	1.8 V power domain. Cannot be pulled up before startup. If unused, keep it open.
BT_EN	139	DO	BT function control via FC20 module	$V_{OLmax} = 0.45\text{ V}$ $V_{OHmin} = 1.35\text{ V}$	1.8 V power domain. If unused, keep it open.

RF Interfaces

Pin Name	Pin No.	I/O	Description	DC Characteristics	Comment
ANT_DIV	35	AI	Diversity antenna		50 Ω impedance. If unused, keep it open.
ANT_MAIN	49	IO	Main antenna		50 Ω impedance.
ANT_GNSS	47	AI	GNSS antenna		50 Ω impedance. If unused, keep it open.

Other Interface Pins

Pin Name	Pin No.	I/O	Description	DC Characteristics	Comment
WAKEUP_IN	1	DI	Sleep mode control	$V_{ILmin} = -0.3\text{ V}$ $V_{ILmax} = 0.6\text{ V}$	1.8 V power domain. Cannot be pulled up

				$V_{IHmin} = 1.2\text{ V}$ $V_{IHmax} = 2.0\text{ V}$	before startup. Low level wakes up the module. If unused, keep it open.
W_DISABLE#	4	DI	Airplane mode control	$V_{ILmin} = -0.3\text{ V}$ $V_{ILmax} = 0.6\text{ V}$ $V_{IHmin} = 1.2\text{ V}$ $V_{IHmax} = 2.0\text{ V}$	1.8 V power domain. Pull-up by default. At low voltage level, module can enter airplane mode. If unused, keep it open.
AP_READY	2	DI	Application processor sleep state detection	$V_{ILmin} = -0.3\text{ V}$ $V_{ILmax} = 0.6\text{ V}$ $V_{IHmin} = 1.2\text{ V}$ $V_{IHmax} = 2.0\text{ V}$	1.8 V power domain. If unused, keep it open.

USB_BOOT Interface

Pin Name	Pin No.	I/O	Description	DC Characteristics	Comment
USB_BOOT	115	DI	Force the module to enter emergency download mode	$V_{ILmin} = -0.3\text{ V}$ $V_{ILmax} = 0.6\text{ V}$ $V_{IHmin} = 1.2\text{ V}$ $V_{IHmax} = 2.0\text{ V}$	1.8 V power domain. Cannot be pulled up before startup. It is recommended to reserve test point.

RESERVED Pins

Pin Name	Pin No.	I/O	Description	DC Characteristics	Comment
RESERVED	3, 18, 43, 55, 73–84, 113, 114, 116, 117, 140-144.		Reserved		Keep these pins unconnected.

NOTES

1. ¹⁾ PCM interface pins are used for audio design on EC25 series module and BT function on FC20 module.
2. BT function is under development.

3.4. Operating Modes

The following table briefly outlines the operating modes to be mentioned in the following chapters.

Table 5: Overview of Operating Modes

Mode	Details	
Normal Operation	Idle	Software is active. The module has registered on the network, and it is ready to send and receive data.
	Talk/Data	Network connection is ongoing. In this mode, the power consumption is decided by network setting and data transfer rate.
Minimum Functionality Mode	AT+CFUN=0 command can set the module to a minimum functionality mode without removing the power supply. In this case, both RF function and (U)SIM card will be invalid.	
Airplane Mode	AT+CFUN=4 command or W_DISABLE# pin can set the module to airplane mode. In this case, RF function will be invalid.	
Sleep Mode	In this mode, the current consumption of the module will be reduced to the minimal level. During this mode, the module can still receive paging message, SMS, voice call and TCP/UDP data from the network normally.	
Power Down Mode	In this mode, the power management unit shuts down the power supply. Software goes inactive. The serial interface is not accessible. Operating voltage (connected to VBAT_RF and VBAT_BB) remains applied.	

3.5. Power Saving

3.5.1. Sleep Mode

EC25 series are able to reduce its current consumption to a minimum value during the sleep mode. The following section describes power saving procedures of EC25 module.

3.5.1.1. UART Application

If the host communicates with module via UART interface, the following preconditions can let the module enter sleep mode.

- Execute **AT+QSCLK=1** command to enable sleep mode.
- Drive DTR to high level.

The following figure shows the connection between the module and the host.

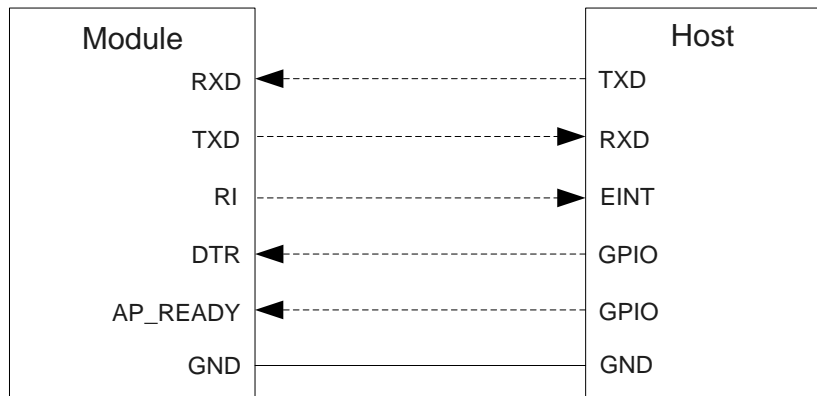

Figure 3: Sleep Mode Application via UART

- Driving the host DTR to low level will wake up the module.
- When EC25 has a URC to report, RI signal will wake up the host. Please refer to **Chapter 3.19** for details about RI behaviors.
- AP_READY will detect the sleep state of the host (can be configured to high level or low level detection). Please refer to **AT+QCFG="apready"** command for details.

3.5.1.2. USB Application with USB Remote Wakeup Function

If the host supports USB suspend/resume and remote wakeup functions, the following three preconditions must be met to let the module enter sleep mode.

- Execute **AT+QSCLK=1** command to enable sleep mode.
- Ensure the DTR is held at high level or keep it open.
- The host’s USB bus, which is connected with the module’s USB interface, enters suspend state.

The following figure shows the connection between the module and the host.

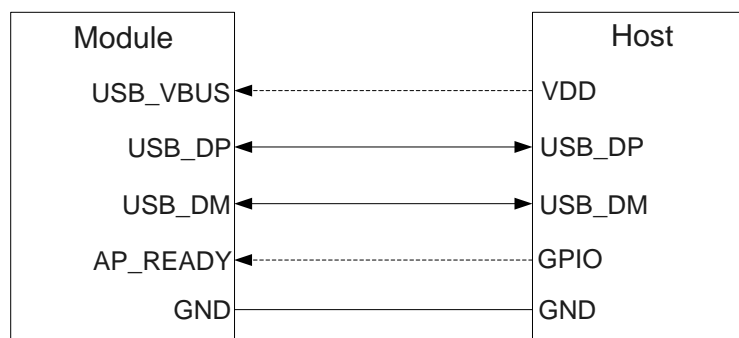

Figure 4: Sleep Mode Application with USB Remote Wakeup

- Sending data to EC25 via USB will wake up the module.
- When EC25 has a URC to report, the module will send remote wake-up signals via USB bus so as to wake up the host.

3.5.1.3. USB Application with USB Suspend/Resume and RI Function

If the host supports USB suspend and resume, but does not support remote wake-up function, the RI signal is needed to wake up the host.

There are three preconditions to let the module enter sleep mode.

- Execute **AT+QSCLK=1** command to enable sleep mode.
- Ensure the DTR is held at high level or keep it open.
- The host's USB bus, which is connected with the module's USB interface, enters suspend state.

The following figure shows the connection between the module and the host.

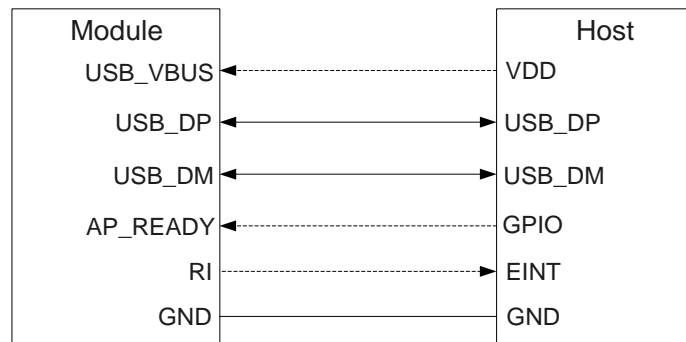

Figure 5: Sleep Mode Application with RI

- Sending data to EC25 via USB will wake up the module.
- When EC25 has a URC to report, RI signal will wake up the host.

3.5.1.4. USB Application without USB Suspend Function

If the host does not support USB suspend function, USB_VBUS should be disconnected via an additional control circuit to let the module enter sleep mode.

- Execute **AT+QSCLK=1** command to enable sleep mode.
- Ensure the DTR is held at high level or keep it open.
- Disconnect USB_VBUS.

The following figure shows the connection between the module and the host.

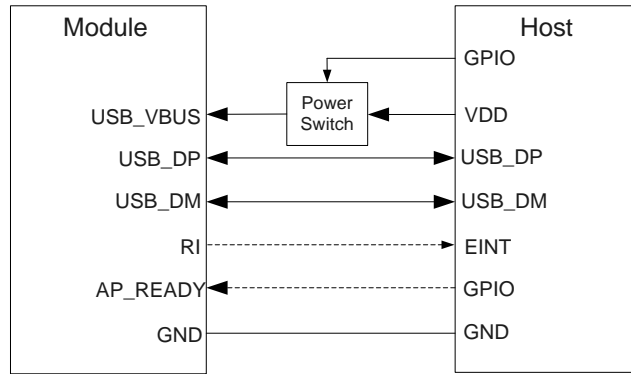

Figure 6: Sleep Mode Application without Suspend Function

Switching on the power switch to supply power to USB_VBUS will wake up the module.

NOTE

Please pay attention to the level match shown in dotted line between the module and the host. For more details about EC25 power management application, please refer to **document [1]**.

3.5.2. Airplane Mode

When the module enters airplane mode, the RF function will be disabled, and all AT commands related to it will be inaccessible. This mode can be set via the following ways.

Hardware:

The W_DISABLE# pin is pulled up by default. Driving it to low level will let the module enter airplane mode.

Software:

AT+CFUN command provides the choice of the functionality level through setting **<fun>** into 0, 1 or 4.

- **AT+CFUN=0:** Minimum functionality mode. Both (U)SIM and RF functions are disabled.
- **AT+CFUN=1:** Full functionality mode (by default).
- **AT+CFUN=4:** Airplane mode. RF function is disabled.

NOTES

1. The W_DISABLE# control function is disabled in firmware by default. It can be enabled by **AT+QCFG="airplanecontrol"** command.
2. The execution of **AT+CFUN** command will not affect GNSS function.

3.6. Power Supply

3.6.1. Power Supply Pins

EC25 provides four VBAT pins for connection with the external power supply. There are two separate voltage domains for VBAT.

- Two VBAT_RF pins for module's RF part
- Two VBAT_BB pins for module's baseband part

The following table shows the details of VBAT pins and ground pins.

Table 6: VBAT and GND Pins

Pin Name	Pin No.	Description	Min.	Typ.	Max.	Unit
VBAT_RF	57, 58	Power supply for module's RF part	3.3	3.8	4.3	V
VBAT_BB	59, 60	Power supply for module's baseband part	3.3	3.8	4.3	V
GND	8, 9, 19, 22, 36, 46, 48, 50–54, 56, 72, 85–112	Ground	-	0	-	V

3.6.2. Decrease Voltage Drop

The power supply range of EC25 is from 3.3 V to 4.3 V. Please make sure that the input voltage will never drop below 3.3 V. The following figure shows the voltage drop during burst transmission in 2G network. The voltage drop will be less in 3G and 4G networks.

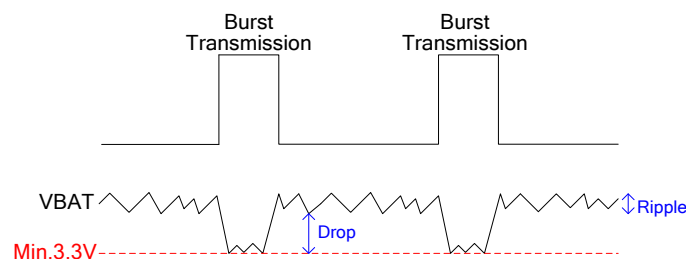

Figure 7: Power Supply Limits during Burst Transmission

To decrease voltage drop, a bypass capacitor of about 100 μF with low ESR (ESR = 0.7 Ω) should be used, and a multi-layer ceramic chip (MLCC) capacitor array should also be reserved due to its ultra-low ESR. It is recommended to use three ceramic capacitors (100 nF, 33 pF, 10 pF) for composing the MLCC

array, and place these capacitors close to VBAT_BB/VBAT_RF pins. The main power supply from an external application has to be a single voltage source and can be expanded to two sub paths with star structure. The width of VBAT_BB trace should be no less than 1 mm; and the width of VBAT_RF trace should be no less than 2 mm. In principle, the longer the VBAT trace is, the wider it will be.

In addition, in order to avoid the damage caused by electric surge and ESD, it is suggested that a TVS diode with suggested low reverse stand-off voltage V_{RWM} 4.5 V, low clamping voltage V_C and high reverse peak pulse current I_{PP} should be used. The following figure shows the star structure of the power supply.

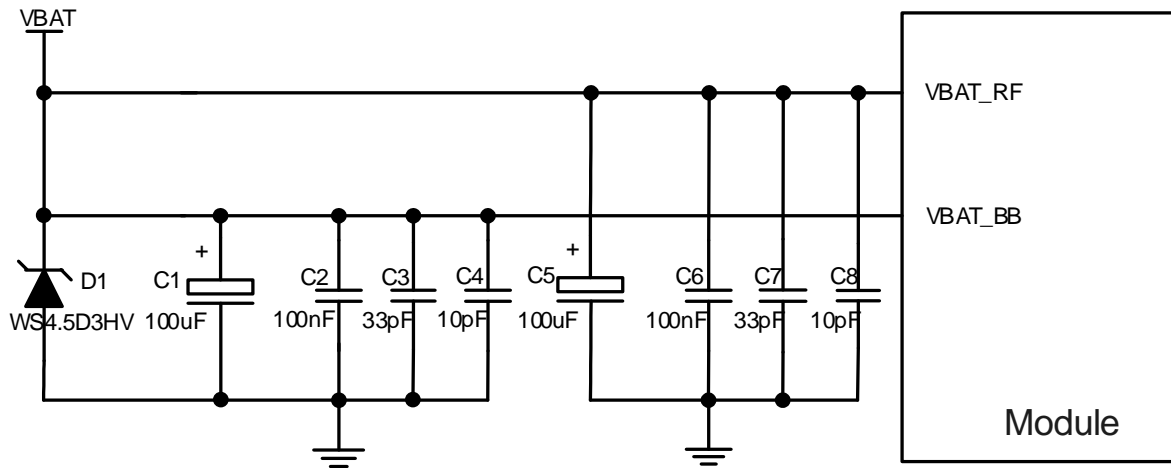

Figure 8: Star Structure of the Power Supply

3.6.3. Reference Design for Power Supply

Power design for the module is very important, as the performance of the module largely depends on the power source. The power supply should be able to provide sufficient current up to 2.0 A at least. If the voltage drop between the input and output is not too high, it is suggested that an LDO should be used to supply power for the module. If there is a big voltage difference between the input source and the desired output (VBAT), a buck converter is preferred to be used as the power supply.

The following figure shows a reference design for +5.0 V input power source. The typical output of the power supply is about 3.8 V and the maximum load current is 3.0 A.

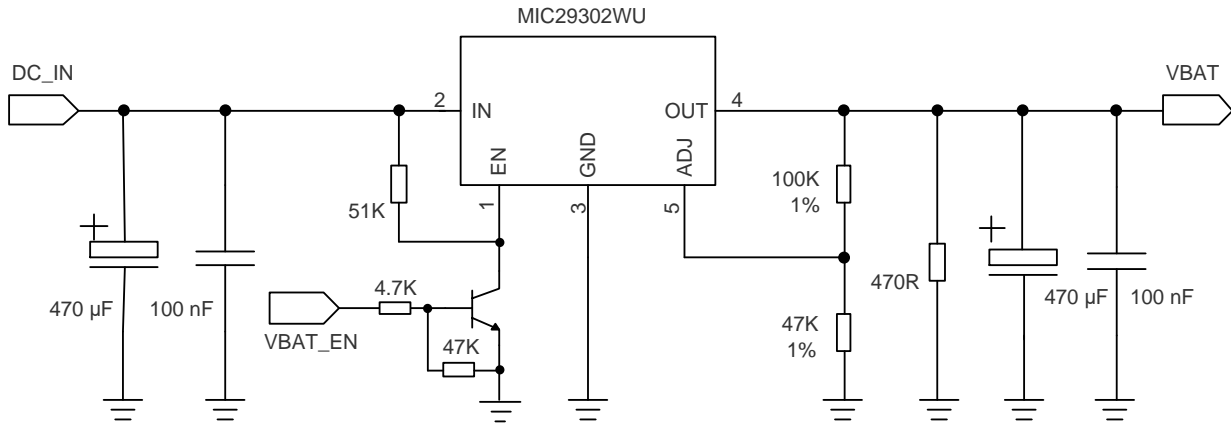

Figure 9: Reference Circuit of Power Supply

NOTE

In order to avoid damaging internal flash, please do not switch off the power supply when the module works normally. Only after the module is shut down by PWRKEY or AT command, then the power supply can be cut off.

3.6.4. Monitor the Power Supply

AT+CBC command can be used to monitor the VBAT_BB voltage value. For more details, please refer to *document [2]*.

3.7. Power-on/off Scenarios

3.7.1. Turn on Module Using the PWRKEY

The following table shows the pin definition of PWRKEY.

Table 7: Pin Definition of PWRKEY

Pin Name	Pin No.	I/O	Description	Comment
PWRKEY	21	DI	Turn on/off the module	The output voltage is 0.8 V because of the diode drop in the Qualcomm chipset.

When EC25 is in power down mode, it can be turned on to normal mode by driving the PWRKEY pin to a low level for at least 500 ms. It is recommended to use an open drain/collector driver to control the PWRKEY. After STATUS pin (require external pull-up resistor) outputs a low level, PWRKEY pin can be

released. A simple reference circuit is illustrated in the following figure.

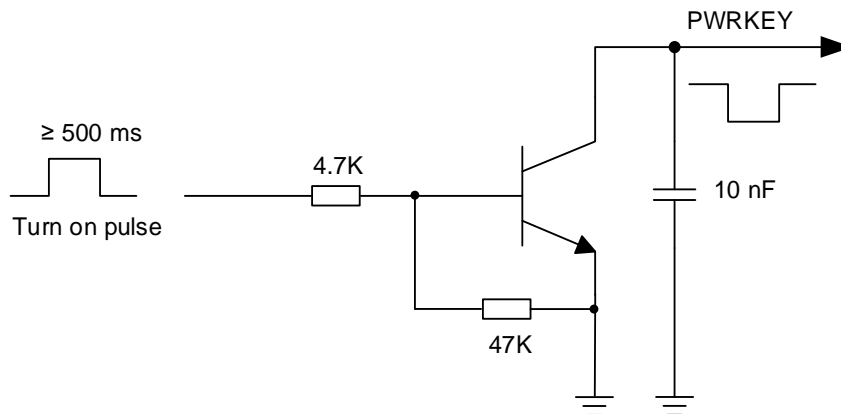

Figure 10: Turn on the Module by Using Driving Circuit

The other way to control the PWRKEY is using a button directly. When pressing the key, electrostatic strike may generate from finger. Therefore, a TVS component is indispensable to be placed nearby the button for ESD protection. A reference circuit is shown in the following figure.

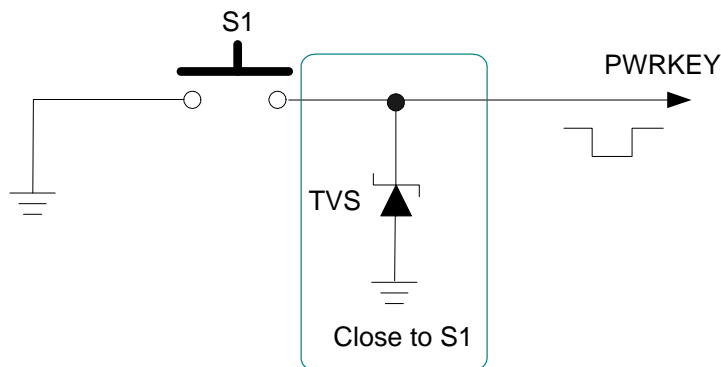

Figure 11: Turn on the Module by Using Keystroke

The power-on scenario is illustrated in the following figure.

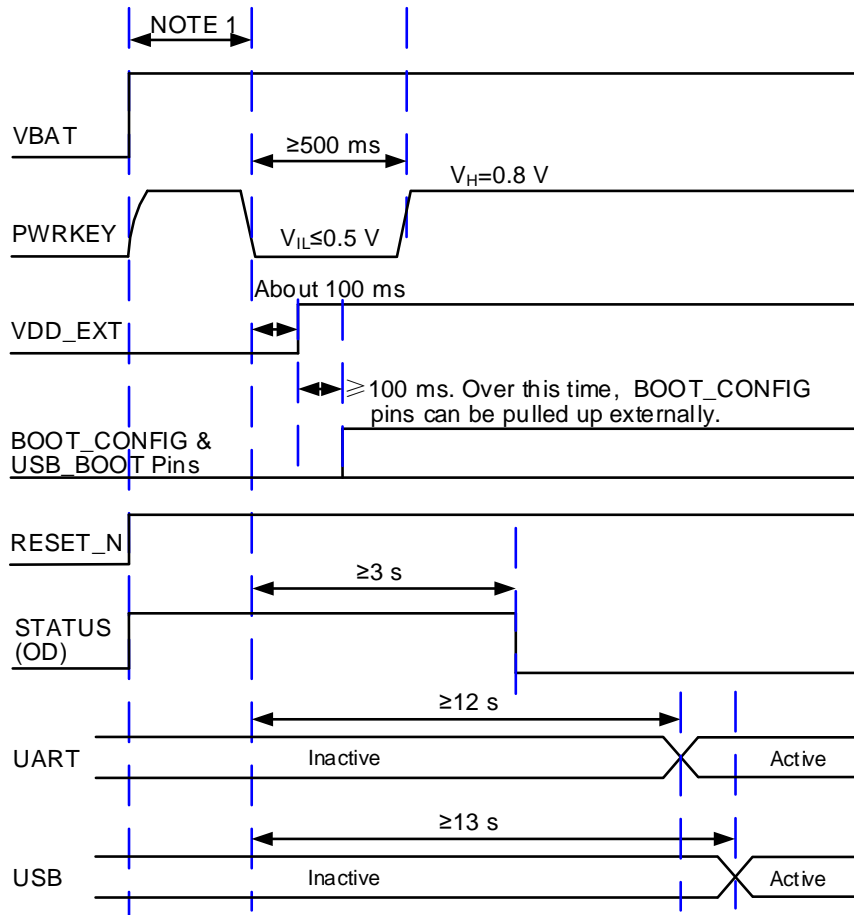

Figure 12: Timing of Turning on Module

NOTES

1. Please make sure that VBAT is stable before pulling down PWRKEY pin. It is recommended that the time between powering up VBAT and pulling down PWRKEY pin is no less than 30 ms.
2. PWRKEY can be pulled down directly to GND with a recommended 10 kΩ resistor if module needs to be powered on automatically and shutdown is not needed.

3.7.2. Turn off Module

The following procedures can be used to turn off the module normally:

- Use the PWRKEY pin.
- Use **AT+QPOWD** command.

3.7.2.1. Turn off Module Using the PWRKEY Pin

Driving the PWRKEY pin to a low level voltage for at least 650 ms, the module will execute power-off procedure after the PWRKEY is released. The power-off scenario is illustrated in the following figure.

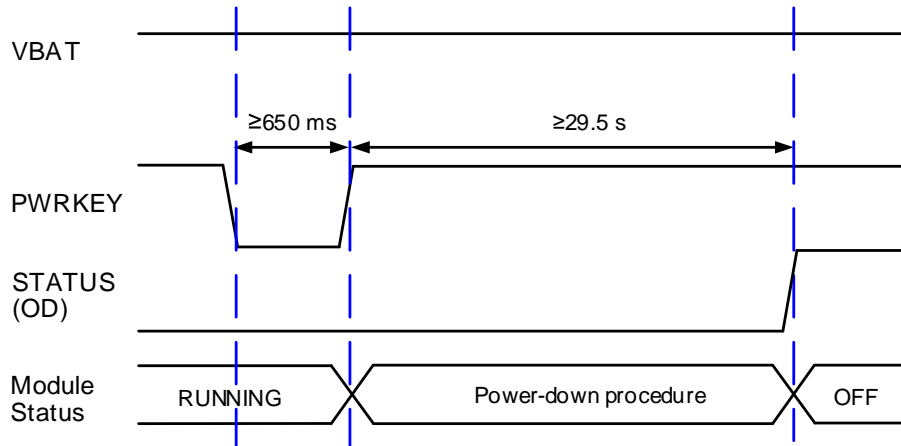

Figure 13: Timing of Turning off Module

3.7.2.2. Turn off Module Using AT Command

It is also a safe way to use **AT+QPOWD** command to turn off the module, which is similar to turning off the module via PWRKEY pin.

Please refer to **document [2]** for details about **AT+QPOWD** command.

NOTES

1. In order to avoid damaging internal flash, please do not switch off the power supply when the module works normally. Only after the module is shut down by PWRKEY or AT command, then the power supply can be cut off.
2. When turning off module with the AT command, please keep PWRKEY at high level after the execution of the command. Otherwise, the module will be turned on again after successfully turn-off.

3.8. Reset Module

The RESET_N pin can be used to reset the module. And module can be reset by driving RESET_N low for 150–460 ms.

Table 8: Pin Definition of RESET_N

Pin Name	Pin No.	I/O	Description	Comment
RESET_N	20	DI	Reset the module	1.8 V power domain

The recommended circuit is similar to the PWRKEY control circuit. An open drain/collector driver or button can be used to control the RESET_N.

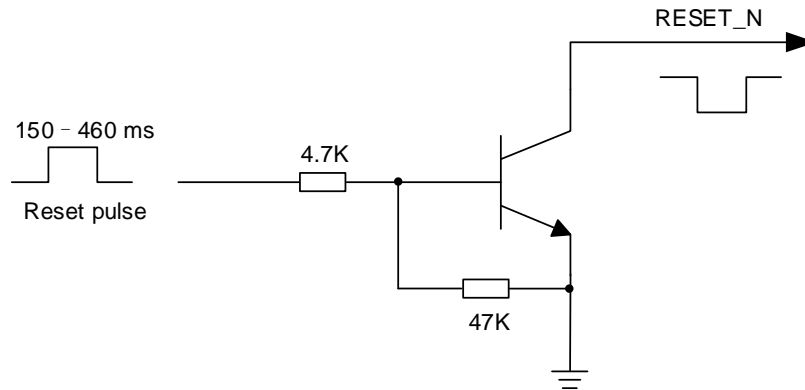

Figure 14: Reference Circuit of RESET_N by Using Driving Circuit

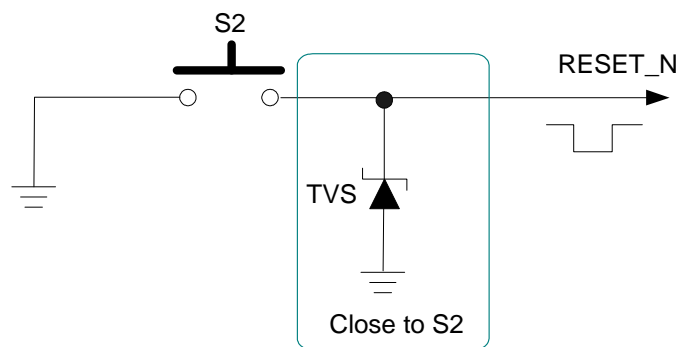

Figure 15: Reference Circuit of RESET_N by Using Button

The reset scenario is illustrated in the following figure.

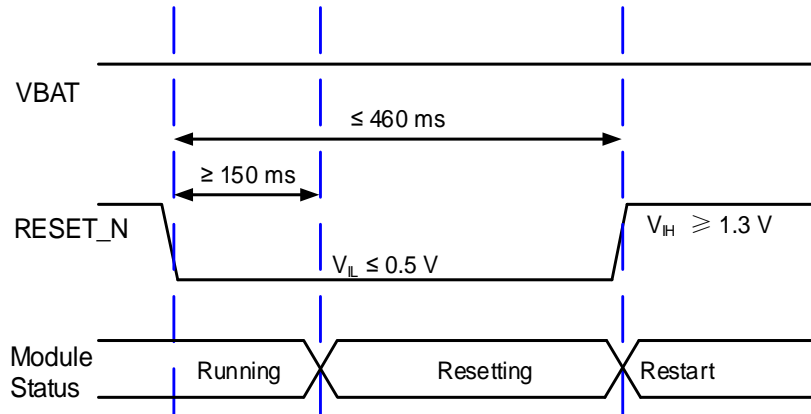

Figure 16: Timing of Resetting Module

NOTES

1. Use RESET_N only when failed to turn off the module by **AT+QPOWD** command and PWRKEY pin.
2. Ensure that there is no large capacitance on PWRKEY and RESET_N pins.

3.9. (U)SIM Interface

The (U)SIM interface circuitry meets ETSI and IMT-2000 requirements. Both 1.8 V and 3.0 V (U)SIM cards are supported.

Table 9: Pin Definition of (U)SIM Interface

Pin Name	Pin No.	I/O	Description	Comment
USIM_VDD	14	PO	Power supply for (U)SIM card	Either 1.8 V or 3.0 V is supported by the module automatically.
USIM_DATA	15	IO	Data signal of (U)SIM card	
USIM_CLK	16	DO	Clock signal of (U)SIM card	
USIM_RST	17	DO	Reset signal of (U)SIM card	
USIM_PRESENCE	13	DI	(U)SIM card insertion detection	1.8 V power domain. If unused, keep it open.
USIM_GND	10		Specified ground for (U)SIM card	

EC25 supports (U)SIM card hot-plug via the USIM_PRESENCE pin. The function supports low level and high level detections. By default, it is disabled, and can be configured via **AT+QSIMDET** command. Please refer to **document [2]** for more details about the command

The following figure shows a reference design for (U)SIM interface with an 8-pin (U)SIM card connector.

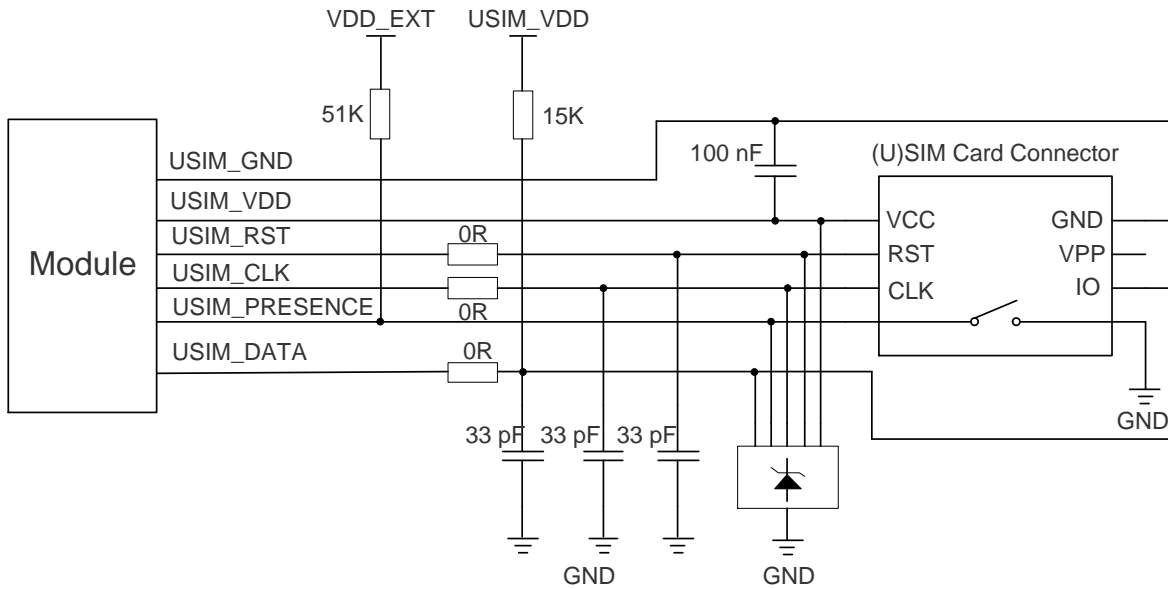

Figure 17: Reference Circuit of (U)SIM Interface with an 8-pin (U)SIM Card Connector

If (U)SIM card detection function is not needed, please keep USIM_PRESENCE unconnected. A reference circuit for (U)SIM interface with a 6-pin (U)SIM card connector is illustrated in the following figure.

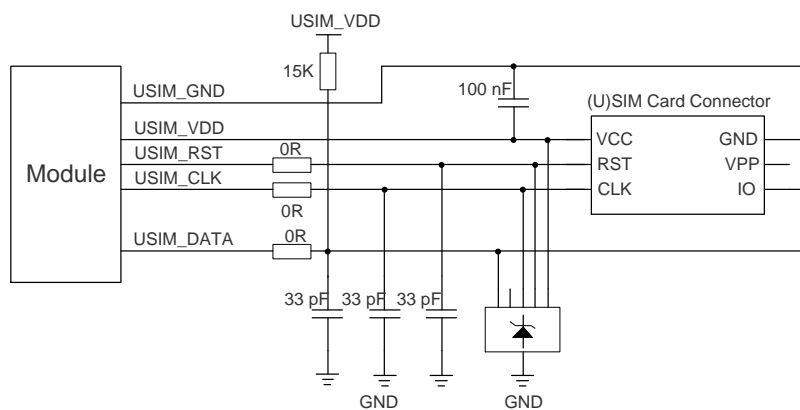

Figure 18: Reference Circuit of (U)SIM Interface with a 6-pin (U)SIM Card Connector

In order to enhance the reliability and availability of the (U)SIM card in customers' applications, please follow the criteria below in (U)SIM circuit design:

- Keep placement of (U)SIM card connector to the module as close as possible. Keep the trace length as less than 200 mm as possible.
- Keep (U)SIM card signals away from RF and VBAT traces.
- Make sure the bypass capacitor between USIM_VDD and USIM_GND less than 1 μ F, and place it as close to (U)SIM card connector as possible. If the ground is complete on customers' PCB, USIM_GND can be connected to PCB ground directly.
- To avoid cross-talk between USIM_DATA and USIM_CLK, keep them away from each other and shield them with surrounded ground.
- In order to offer good ESD protection, it is recommended to add a TVS diode array whose parasitic capacitance should not be more than 15 pF. The 0 Ω resistors should be added in series between the module and the (U)SIM card to facilitate debugging. The 33 pF capacitors are used for filtering interference of EGSM900. Please note that the (U)SIM peripheral circuit should be close to the (U)SIM card connector.
- The pull-up resistor on USIM_DATA line can improve anti-jamming capability when long layout trace and sensitive occasion are applied, and should be placed close to the (U)SIM card connector.

3.10. USB Interface

EC25 contains one integrated Universal Serial Bus (USB) interface which complies with the USB 2.0 specification and supports high-speed (480 Mbps) and full-speed (12 Mbps) modes. The USB interface can only serve as a slave device and is used for AT command communication, data transmission, GNSS NMEA sentences output, software debugging, firmware upgrade and voice over USB. The following table shows the pin definition of USB interface.

Table 10: Pin Description of USB Interface

Pin Name	Pin No.	I/O	Description	Comment
USB_DP	69	IO	USB differential data bus (+)	Require differential impedance of 90 Ω
USB_DM	70	IO	USB differential data bus (-)	Require differential impedance of 90 Ω
USB_VBUS	71	PI	USB connection detection USB detection	Typical 5.0 V
GND	72		Ground	

For more details about the USB 2.0 specifications, please visit <http://www.usb.org/home>.

The USB interface is recommended to be reserved for firmware upgrade in customers' designs. The following figure shows a reference circuit of USB interface.

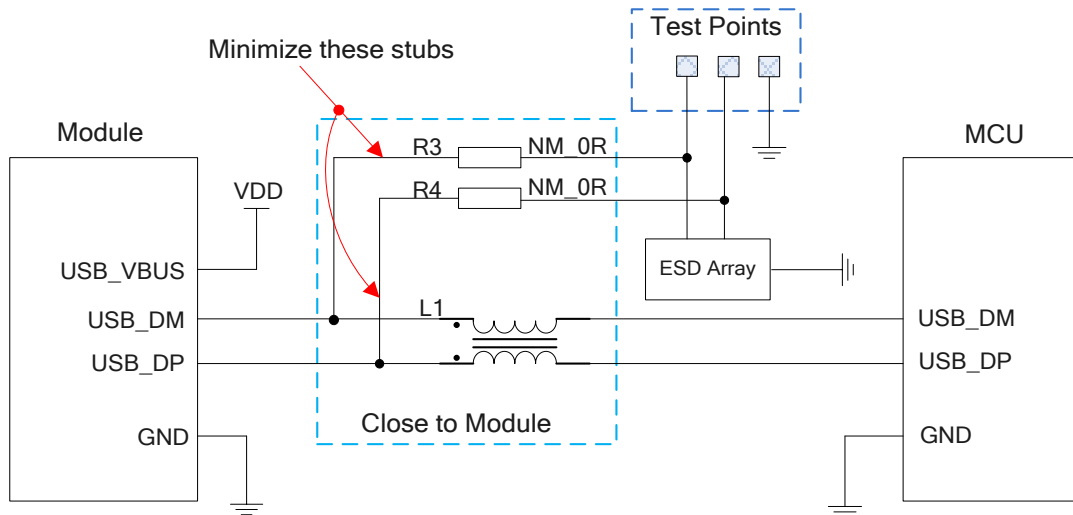

Figure 19: Reference Circuit of USB Application

A common mode choke L1 is recommended to be added in series between the module and customer’s MCU in order to suppress EMI spurious transmission. Meanwhile, the 0 Ω resistors (R3 and R4) should be added in series between the module and the test points so as to facilitate debugging, and the resistors are not mounted by default. In order to ensure the integrity of USB data line signal, L1/R3/R4 components must be placed close to the module, and also these resistors should be placed close to each other. The extra stubs of trace must be as short as possible.

The following principles should be complied with when design the USB interface, so as to meet USB 2.0 specification.

- It is important to route the USB signal traces as differential pairs with ground surrounded. The impedance of USB differential trace is 90 Ω.
- Do not route signal traces under crystals, oscillators, magnetic devices and RF signal traces. It is important to route the USB differential traces in inner-layer of the PCB, and surround the traces with ground on that layer and with ground planes above and below.
- Junction capacitance of the ESD protection device might cause influences on USB data lines, so please pay attention to the selection of the device. Typically, the stray capacitance should be less than 2 pF.
- Keep the ESD protection devices to the USB connector as close as possible.

3.11. UART Interfaces

The module provides two UART interfaces: the main UART interface and the debug UART interface. The following shows their features.

- The main UART interface supports 4800 bps, 9600 bps, 19200 bps, 38400 bps, 57600 bps, 115200

bps, 230400 bps, 460800 bps and 921600 bps baud rates, and the default is 115200 bps. It also supports RTS and CTS hardware flow control, and can be used for data transmission and AT command communication.

- The debug UART interface supports 115200 bps baud rate. It is used for Linux console and log output.

The following tables show the pin definition of the UART interfaces.

Table 11: Pin Definition of Main UART Interface

Pin Name	Pin No.	I/O	Description	Comment
RI	62	DO	Ring indicator	
DCD	63	DO	Data carrier detection	
CTS	64	DO	Clear to send	
RTS	65	DI	Request to send	1.8 V power domain
DTR	66	DI	Data terminal ready, sleep mode control	
TXD	67	DO	Transmit data	
RXD	68	DI	Receive data	

Table 12: Pin Definition of Debug UART Interface

Pin Name	Pin No.	I/O	Description	Comment
DBG_TXD	12	DO	Transmit data	1.8 V power domain
DBG_RXD	11	DI	Receive data	

The logic levels are described in the following table.

Table 13: Logic Levels of Digital I/O

Parameter	Min.	Max.	Unit
V _{IL}	-0.3	0.6	V
V _{IH}	1.2	2.0	V

V _{OL}	0	0.45	V
V _{OH}	1.35	1.8	V

The module provides 1.8 V UART interface. A level translator should be used if customers' application is equipped with a 3.3 V UART interface. A level translator TXS0108EPWR provided by *Texas Instruments* is recommended. The following figure shows a reference design.

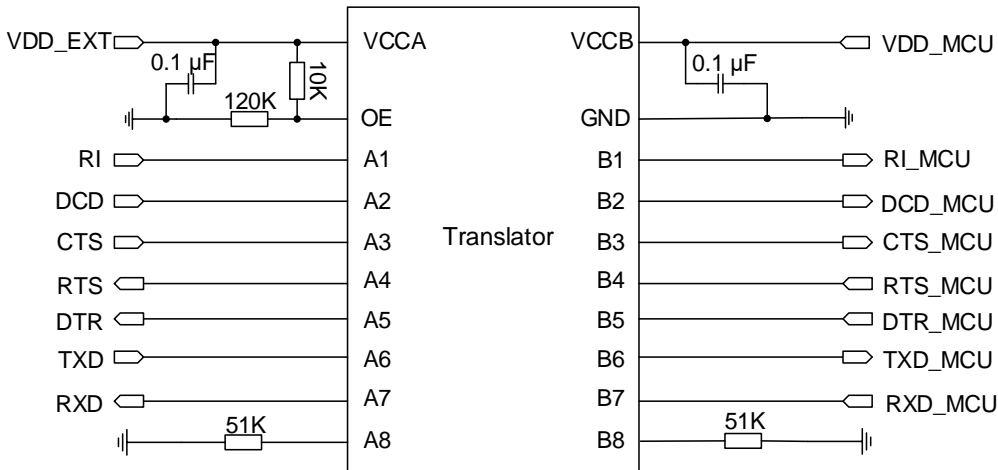

Figure 20: Reference Circuit with Translator Chip

Please visit <http://www.ti.com> for more information.

Another example with transistor translation circuit is shown as below. For the design of circuits shown in dotted lines, please refer to that shown in solid lines, but please pay attention to the direction of connection.

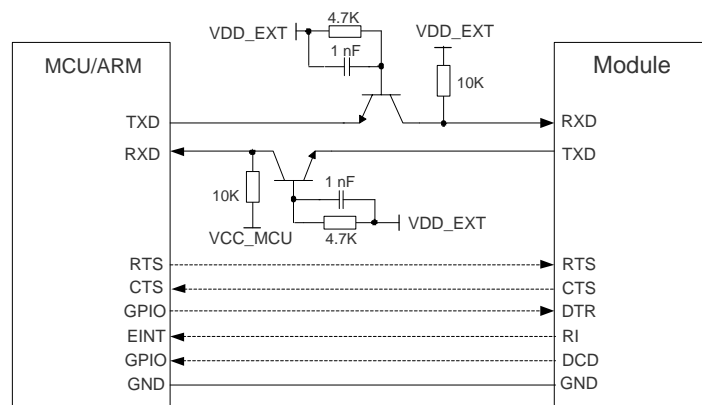

Figure 21: Reference Circuit with Transistor Circuit

NOTE

Transistor circuit solution is not suitable for applications with high baud rates exceeding 460 kbps.

3.12. PCM and I2C Interfaces

EC25 provides one Pulse Code Modulation (PCM) digital interface for audio design, which supports the following modes and one I2C interface:

- Primary mode (short frame synchronization, works as both master and slave)
- Auxiliary mode (long frame synchronization, works as master only)

In primary mode, the data is sampled on the falling edge of the PCM_CLK and transmitted on the rising edge. The PCM_SYNC falling edge represents the MSB. In this mode, the PCM interface supports 256 kHz, 512 kHz, 1024 kHz or 2048 kHz PCM_CLK at 8 kHz PCM_SYNC, and also supports 4096 kHz PCM_CLK at 16 kHz PCM_SYNC.

In auxiliary mode, the data is sampled on the falling edge of the PCM_CLK and transmitted on the rising edge. The PCM_SYNC rising edge represents the MSB. In this mode, the PCM interface operates with a 256 kHz, 512 kHz, 1024 kHz or 2048 kHz PCM_CLK and an 8 kHz, 50% duty cycle PCM_SYNC.

EC25 supports 16-bit linear data format. The following figures show the primary mode's timing relationship with 8 kHz PCM_SYNC and 2048 kHz PCM_CLK, as well as the auxiliary mode's timing relationship with 8 kHz PCM_SYNC and 256 kHz PCM_CLK.

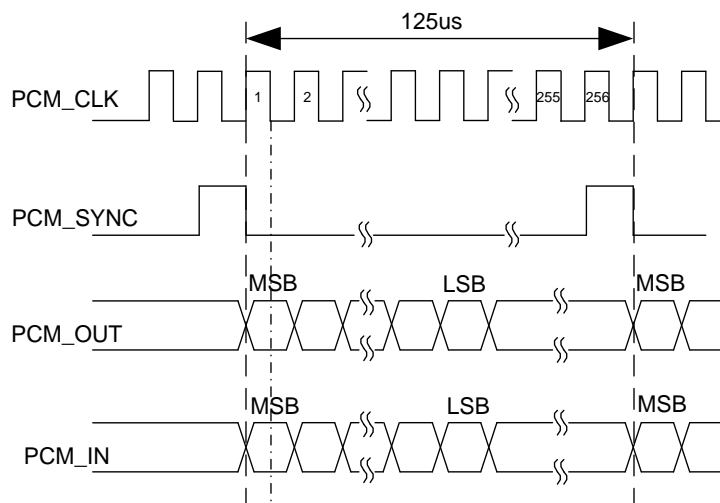

Figure 22: Primary Mode Timing

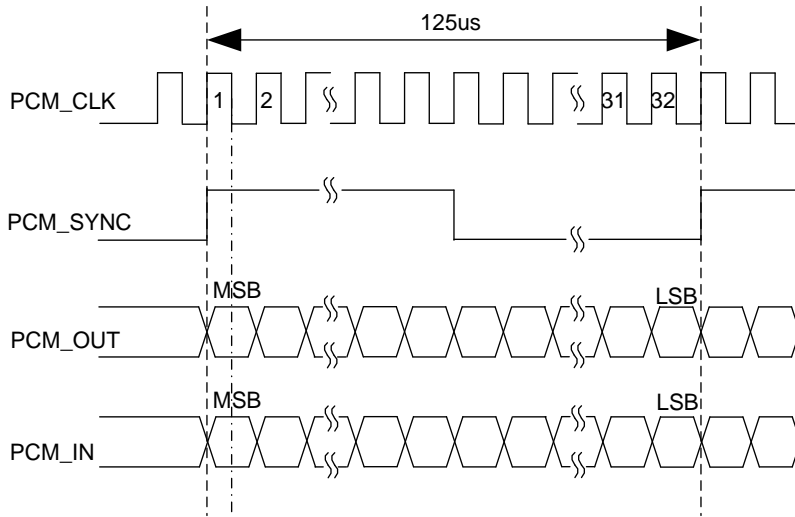

Figure 23: Auxiliary Mode Timing

The following table shows the pin definition of PCM and I2C interfaces which can be applied on audio codec design.

Table 14: Pin Definition of PCM and I2C Interfaces

Pin Name	Pin No.	I/O	Description	Comment
PCM_IN	24	DI	PCM data input	1.8 V power domain
PCM_OUT	25	DO	PCM data output	1.8 V power domain
PCM_SYNC	26	IO	PCM data frame synchronization signal	1.8 V power domain
PCM_CLK	27	IO	PCM data bit clock	1.8 V power domain
I2C_SCL	41	OD	I2C serial clock	Require external pull-up to 1.8 V
I2C_SDA	42	OD	I2C serial data	Require external pull-up to 1.8 V

Clock and mode can be configured by AT command, and the default configuration is master mode using short frame synchronization format with 2048 kHz PCM_CLK and 8 kHz PCM_SYNC. Please refer to **document [2]** for more details about **AT+QDAI** command.

The following figure shows a reference design of PCM and I2C interfaces with external codec IC.

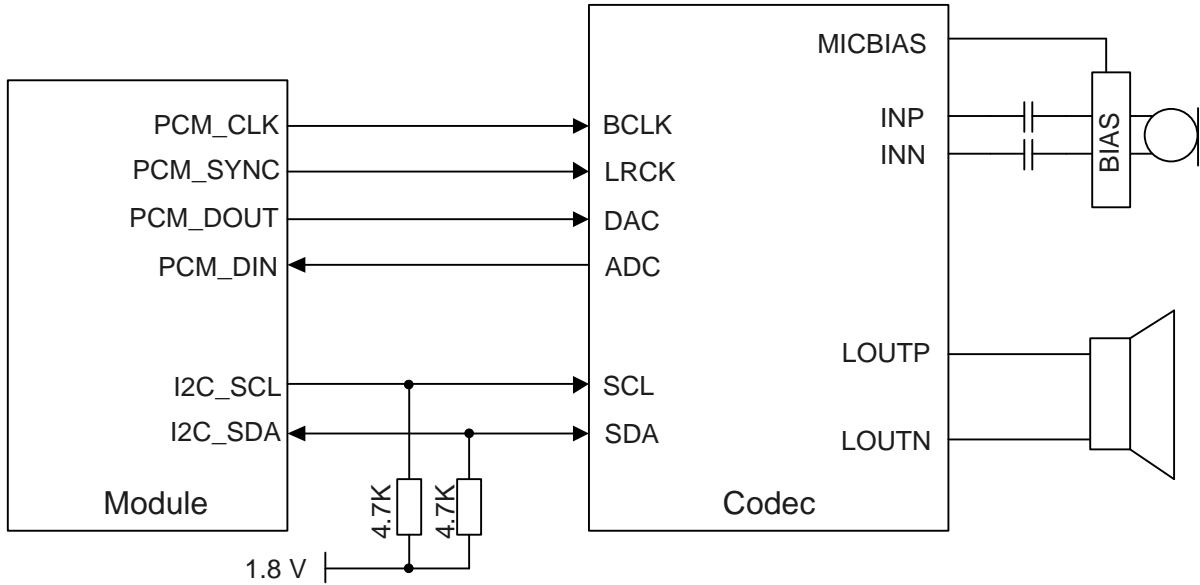

Figure 24: Reference Circuit of PCM and I2C Application with Audio Codec

NOTES

1. It is recommended to reserve an RC (R = 22 Ω, C = 22 pF) circuits on the PCM lines, especially for PCM_CLK.
2. EC25 works as a master device pertaining to I2C interface.

3.13. SD Card Interface

EC25 supports SDIO 3.0 interface for SD card.

The following table shows the pin definition of SD card interface.

Table 15: Pin Definition of SD Card Interface

Pin Name	Pin No.	I/O	Description	Comment
SDC2_DATA3	28	IO	SD card SDIO bus DATA3	SDIO signal level can be selected according to SD card supported level, please refer to SD 3.0 protocol for more details. If unused, keep it open.
SDC2_DATA2	29	IO	SD card SDIO bus DATA2	
SDC2_DATA1	30	IO	SD card SDIO bus DATA1	
SDC2_DATA0	31	IO	SD card SDIO bus DATA0	

SDC2_CLK	32	DO	SD card SDIO bus clock	
SDC2_CMD	33	IO	SD card SDIO bus command	
VDD_SDIO	34	PO	SD card SDIO bus pull up power	1.8/2.85 V configurable. Cannot be used for SD card power. If unused, keep it open.
SD_INS_DET	23	DI	SD card insertion detection	1.8 V power domain. If unused, keep it open.

The following figure shows a reference design of SD card.

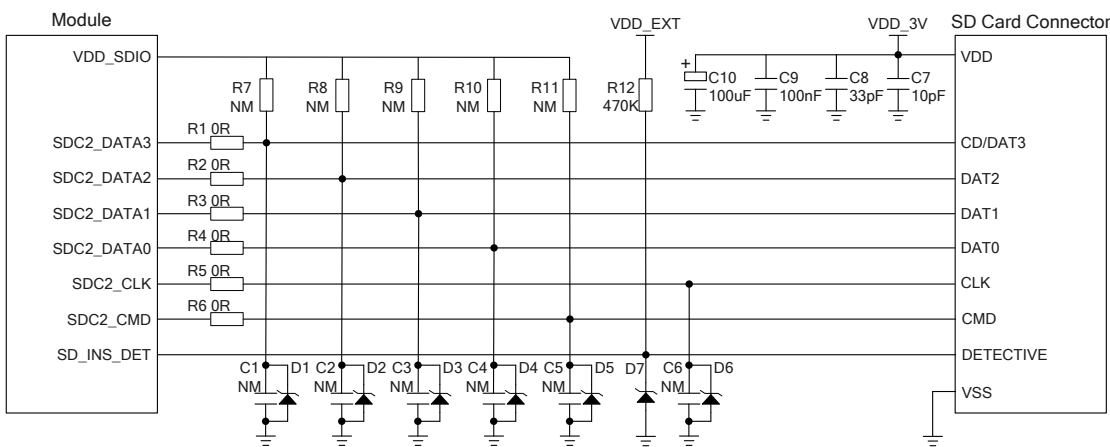

Figure 25: Reference Circuit of SD Card Interface

In SD card interface design, in order to ensure good communication performance with SD card, the following design principles should be complied with:

- SD_INS_DET must be connected.
- The voltage range of SD card power supply VDD_3 V is 2.7–3.6 V and a sufficient current up to 0.8 A should be provided. As the maximum output current of VDD_SDIO is 50 mA which can only be used for SDIO pull-up resistors, an externally power supply is needed for SD card.
- To avoid jitter of bus, resistors R7–R11 are needed to pull up the SDIO to VDD_SDIO. Value of these resistors is among 10–100 kΩ and the recommended value is 100 kΩ. VDD_SDIO should be used as the pull-up power.
- In order to adjust signal quality, it is recommended to add 0 Ω resistors R1–R6 in series between the module and the SD card. The bypass capacitors C1–C6 are reserved and not mounted by default. All resistors and bypass capacitors should be placed close to the module.
- In order to offer good ESD protection, it is recommended to add a TVS diode on SD card pins near the SD card connector with junction capacitance less than 15 pF.
- Keep SDIO signals far away from other sensitive circuits/signals such as RF circuits, analog signals, etc., as well as noisy signals such as clock signals, DC-DC signals, etc.

- It is important to route the SDIO signal traces with total grounding. The impedance of SDIO data trace is 50 Ω (±10%).
- Make sure the adjacent trace spacing is two times of the trace width and the load capacitance of SDIO bus should be less than 15 pF.
- It is recommended to keep the trace length difference between CLK and DATA/CMD less than 1 mm and the total routing length less than 50 mm. The total trace length inside the module is 27 mm, so the exterior total trace length should be less than 23 mm.

3.14. Wireless Connectivity Interfaces

EC25 supports a low-power SDIO 3.0 interface for WLAN and UART/PCM interfaces for BT function.

The following table shows the pin definition of wireless connectivity interfaces.

Table 16: Pin Definition of Wireless Connectivity Interfaces

Pin Name	Pin No.	I/O	Description	Comment
WLAN Part				
SDC1_DATA3	129	IO	WLAN SDIO data bus D3	1.8 V power domain
SDC1_DATA2	130	IO	WLAN SDIO data bus D2	1.8 V power domain
SDC1_DATA1	131	IO	WLAN SDIO data bus D1	1.8 V power domain
SDC1_DATA0	132	IO	WLAN SDIO data bus D0	1.8 V power domain
SDC1_CLK	133	DO	WLAN SDIO bus clock	1.8 V power domain
SDC1_CMD	134	IO	WLAN SDIO bus command	1.8 V power domain
WLAN_EN	136	DO	WLAN function control via FC20 module.	1.8 V power domain. Active high. Cannot be pulled up before startup. If unused, keep it open.
Coexistence and Control Part				
PM_ENABLE	127	DO	WLAN power control	1.8 V power domain Active high.
WAKE_ON_WIRELESS	135	DI	Wake up the host (EC25 module) by FC20 module	1.8 V power domain

COEX_UART_RX	137	DI	LTE/WLAN & BT coexistence signal	1.8 V power domain. Cannot be pulled up before startup. If unused, keep it open.
COEX_UART_TX	138	DO	LTE/WLAN & BT coexistence signal	1.8 V power domain. Cannot be pulled up before startup. If unused, keep it open.
WLAN_SLP_CLK	118	DO	WLAN sleep clock	
BT Part				
BT_RTS	37	DI	BT UART request to send	1.8 V power domain
BT_TXD	38	DO	BT UART transmit data	1.8 V power domain
BT_RXD	39	DI	BT UART receive data	1.8 V power domain
BT_CTS	40	DO	BT UART clear to send	1.8 V power domain. Cannot be pulled up before startup. If unused, keep it open.
PCM_IN ¹⁾	24	DI	PCM data input	1.8 V power domain
PCM_OUT ¹⁾	25	DO	PCM data output	1.8 V power domain
PCM_SYNC ¹⁾	26	IO	PCM data frame synchronization signal	1.8 V power domain
PCM_CLK ¹⁾	27	IO	PCM data bit clock	1.8 V power domain
BT_EN	139	DO	BT function control via FC20 module.	1.8 V power domain Active high.

The following figure shows a reference design of wireless connectivity interfaces with Quectel FC20 module.

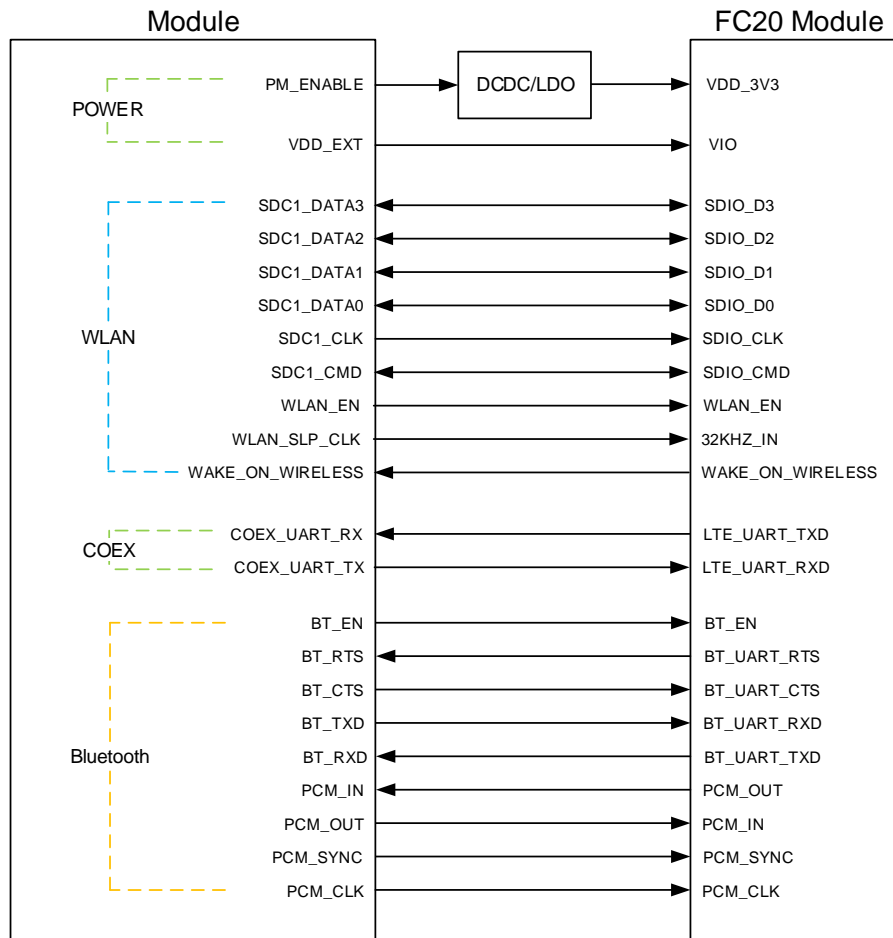

Figure 26: Reference Circuit of Wireless Connectivity Interfaces with FC20 Module

NOTES

1. FC20 module can only be used as a slave device.
2. When BT function is enabled on EC25 module, PCM_SYNC and PCM_CLK pins are only used to output signals. BT function is under development.
3. ¹⁾ Pins 24–27 for PCM function are used for audio design on EC25 module and BT function on FC20 module.
4. For more information about wireless connectivity interfaces, please refer to **document [5]**.

3.14.1. WLAN Interface

EC25 provides a low-power SDIO 3.0 interface and control interface for WLAN design.

SDIO interface supports SDR mode, and the maximum frequency is up to 50 MHz.

As SDIO signals are very high-speed, in order to ensure the SDIO interface design corresponds with the SDIO 3.0 specification, please comply with the following principles:

- It is important to route the SDIO signal traces with total grounding. The impedance of SDIO signal trace is $50 \Omega \pm 10\%$.
- Keep SDIO signals far away from other sensitive circuits/signals such as RF circuits, analog signals, etc., as well as noisy signals such as clock signals, DC-DC signals, etc.
- It is recommended to keep matching length between CLK and DATA/CMD less than 1 mm and total routing length less than 50 mm.
- Keep termination resistors within 15–24 Ω on clock lines near the module and keep the route distance from the module clock pins to termination resistors less than 5 mm.
- Make sure the adjacent trace spacing is 2 times of the trace width and bus capacitance is less than 15 pF.

3.14.2. BT Interface

EC25 supports a dedicated UART interface and a PCM interface for BT application.

BT UART interface supports high-speed UART operation up to 3 Mbps. It also supports RTS and CTS hardware flow control.

As UART signals are very high-speed, in order to ensure the BT UART interface works normal, please comply with the following principles:

- The module provides 1.8 V BT UART interface. A level translator should be used if customers' application is equipped with a 3.3 V UART interface. Make sure the level translator support high rate data transmission.
- Make sure the communication cable support high rate data transmission.

3.15. ADC Interfaces

The module provides two analog-to-digital converter (ADC) interfaces. **AT+QADC=0** command can be used to read the voltage value on ADC0 pin. **AT+QADC=1** command can be used to read the voltage value on ADC1 pin. For more details about these AT commands, please refer to **document [2]**.

In order to improve the accuracy of ADC, the trace of ADC should be surrounded by ground.

Table 17: Pin Definition of ADC Interfaces

Pin Name	Pin No.	Description
ADC0	45	General-purpose analog to digital converter

ADC1 44 General-purpose analog to digital converter

The following table describes the characteristic of ADC function.

Table 18: Characteristic of ADC

Parameter	Min.	Typ.	Max.	Unit
ADC0 Voltage Range	0.3		VBAT_BB	V
ADC1 Voltage Range	0.3		VBAT_BB	V
ADC Resolution		15		bits

NOTES

1. ADC input voltage must not exceed that of VBAT_BB.
2. It is prohibited to supply any voltage to ADC pins when VBAT power supply is removed.
3. It is recommended to use a resistor divider circuit for ADC application.

3.16. SGMII Interface

EC25 includes an integrated Ethernet MAC with an SGMII interface and two management interfaces. The key features of the SGMII interface are shown below:

- IEEE802.3 compliant
- Support 10 Mbps/100 Mbps/1000 Mbps Ethernet work mode
- Support maximum 150 Mbps (DL)/50 Mbps (UL) for 4G network
- Support VLAN tagging
- Support IEEE1588 and Precision Time Protocol (PTP)
- Can be used to connect to external Ethernet PHY like AR8033, or to an external switch
- Management interfaces support dual voltage 1.8/2.85 V

The following table shows the pin definition of SGMII interface.

Table 19: Pin Definition of SGMII Interface

Pin Name	Pin No.	I/O	Description	Comment
Control Signal Part				

EPHY_RST_N	119	DO	Ethernet PHY reset	1.8/2.85 V power domain
EPHY_INT_N	120	DI	Ethernet PHY interrupt	1.8 V power domain
SGMII_MDATA	121	IO	SGMII MDIO (Management Data Input/Output) data	1.8/2.85 V power domain
SGMII_MCLK	122	DO	SGMII MDIO (Management Data Input/Output) clock	1.8/2.85 V power domain
USIM2_VDD	128	PO	SGMII MDIO pull-up power source	Configurable power source. 1.8/2.85 V power domain.

SGMII Signal Part

SGMII_TX_M	123	AO	SGMII transmission - minus	Connect with a 0.1 μ F capacitor, and is close to the PHY side.
SGMII_TX_P	124	AO	SGMII transmission - plus	
SGMII_RX_P	125	AI	SGMII receiving - plus	Connect with a 0.1 μ F capacitor, and is close to EC25 module.
SGMII_RX_M	126	AI	SGMII receiving - minus	

The following figure shows the simplified block diagram for Ethernet application.

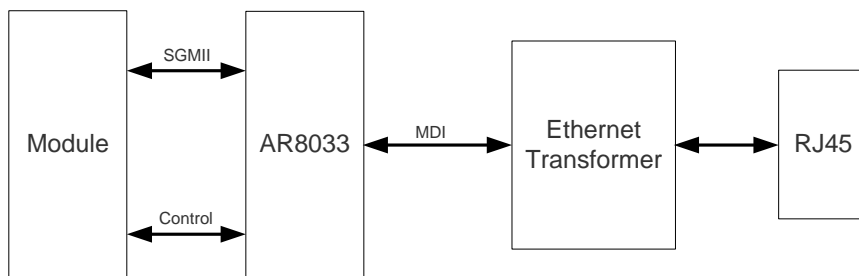

Figure 27: Simplified Block Diagram for Ethernet Application

The following figure shows a reference design of SGMII interface with PHY AR8033 application.

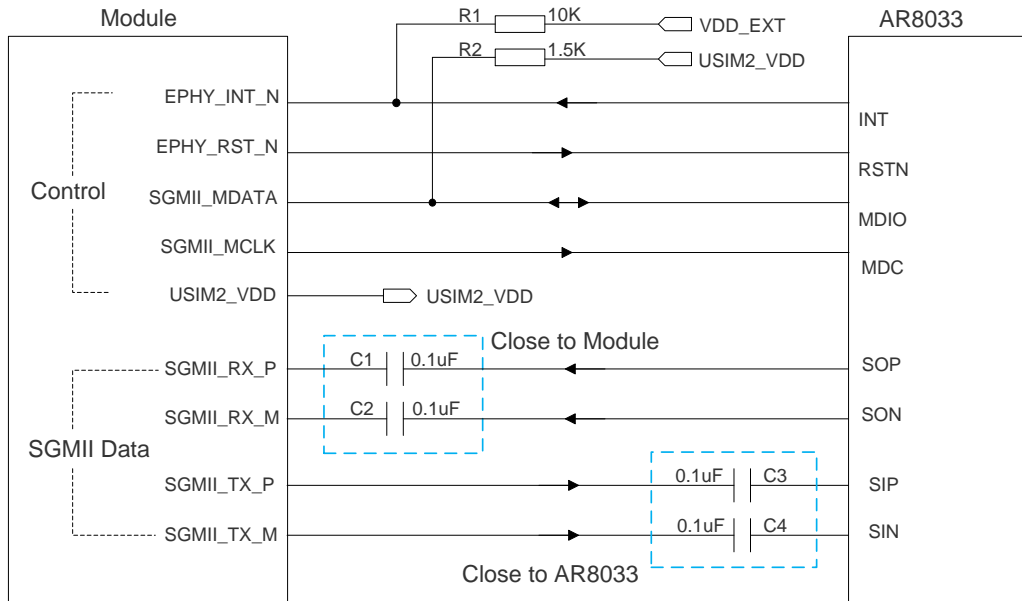

Figure 28: Reference Circuit of SGMII Interface with PHY AR8033 Application

In order to enhance the reliability and availability in customers' applications, please follow the criteria below in the Ethernet PHY circuit design:

- Keep SGMII data and control signals away from other sensitive circuits/signals such as RF circuits, analog signals, etc., as well as noisy signals such as clock signals, DC-DC signals, etc.
- Keep the maximum trace length less than 10-inch and keep skew on the differential pairs less than 20 mil.
- The differential impedance of SGMII data trace is $100\ \Omega \pm 10\%$, and the reference ground of the area should be complete.
- Make sure the trace spacing between SGMII RX and TX is at least 3 times of the trace width, and the same to the adjacent signal traces.

3.17. Network Status Indication

The network indication pins can be used to drive network status indication LEDs. The module provides two pins which are NET_MODE and NET_STATUS. The following tables describe the pin definition and logic level changes in different network status.

Table 20: Pin Definition of Network Connection Status/Activity Indicator

Pin Name	Pin No.	I/O	Description	Comment
NET_MODE	5	DO	Indicate the module's network registration mode	1.8 V power domain Cannot be pulled up before startup
NET_STATUS	6	DO	Indicate the module's network activity status	1.8 V power domain

Table 21: Working State of Network Connection Status/Activity Indicator

Pin Name	Logic Level Changes	Network Status
NET_MODE	Always High	Registered on LTE network
	Always Low	Others
NET_STATUS	Flicker slowly (200 ms High/1800 ms Low)	Network searching
	Flicker slowly (1800 ms High/200 ms Low)	Idle
	Flicker quickly (125 ms High/125 ms Low)	Data transfer is ongoing
	Always High	Voice calling

A reference circuit is shown in the following figure.

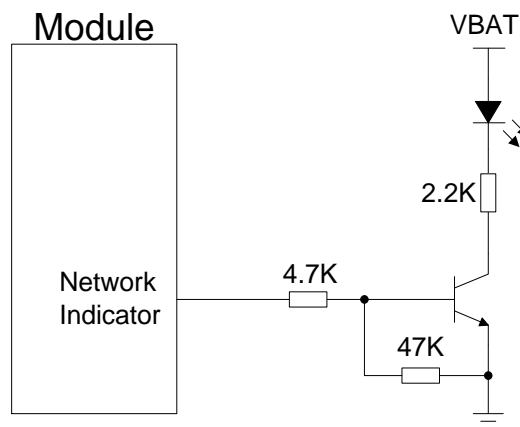

Figure 29: Reference Circuit of the Network Indicator

3.18. STATUS

The STATUS pin is an open drain output for indicating the module’s operation status. It can be connected to a GPIO of DTE with a pull-up resistor, or as LED indication circuit as below. When the module is turned on normally, the STATUS will present the low state. Otherwise, the STATUS will present high-impedance state.

Table 22: Pin Definition of STATUS

Pin Name	Pin No.	I/O	Description	Comment
STATUS	61	OD	Indicate the module’s operation status	An external pull-up resistor is required. If unused, keep it open.

The following figure shows different circuit designs of STATUS, and customers can choose either one according to customers’ application demands.

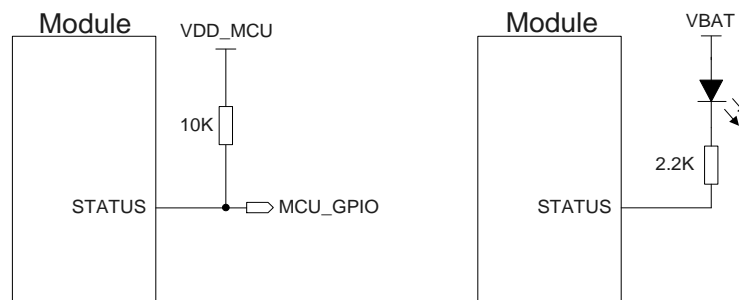

Figure 30: Reference Circuits of STATUS

NOTE

The status pin cannot be used as indication of module shutdown status when VBAT power supply is removed.

3.19. Behaviors of RI

AT+QCFG="risignaltpe","physical" command can be used to configure RI behavior.

No matter on which port a URC is presented, the URC will trigger the behaviors of RI pin.

NOTE

URC can be outputted from UART port, USB AT port and USB modem port through configuration via **AT+QURCCFG** command. The default port is USB AT port.

In addition, RI behavior can be configured flexibly. The default behaviors of the RI is shown as below.

Table 23: Behaviors of RI

State	Response
Idle	RI keeps at high level
URC	RI outputs 120 ms low pulse when a new URC returns

The RI behavior can be changed by **AT+QCFG="urc/ri/ring"** command. Please refer to *document [2]* for details.

3.20. USB_BOOT Interface

EC25 provides a USB_BOOT pin. Customers can pull up USB_BOOT to 1.8 V before VDD_EXT is powered up, and the module will enter emergency download mode when it is powered on. In this mode, the module supports firmware upgrade over USB interface.

Table 24: Pin Definition of USB_BOOT Interface

Pin Name	Pin No.	I/O	Description	Comment
USB_BOOT	115	DI	Force the module to enter emergency download mode	1.8 V power domain. Active high. It is recommended to reserve test points.

The following figure shows a reference circuit of USB_BOOT interface.

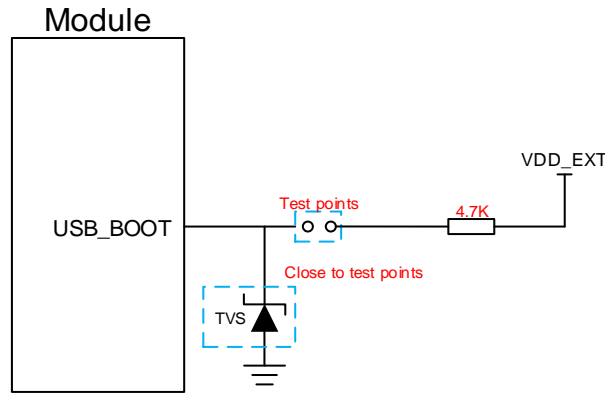

Figure 31: Reference Circuit of USB_BOOT Interface

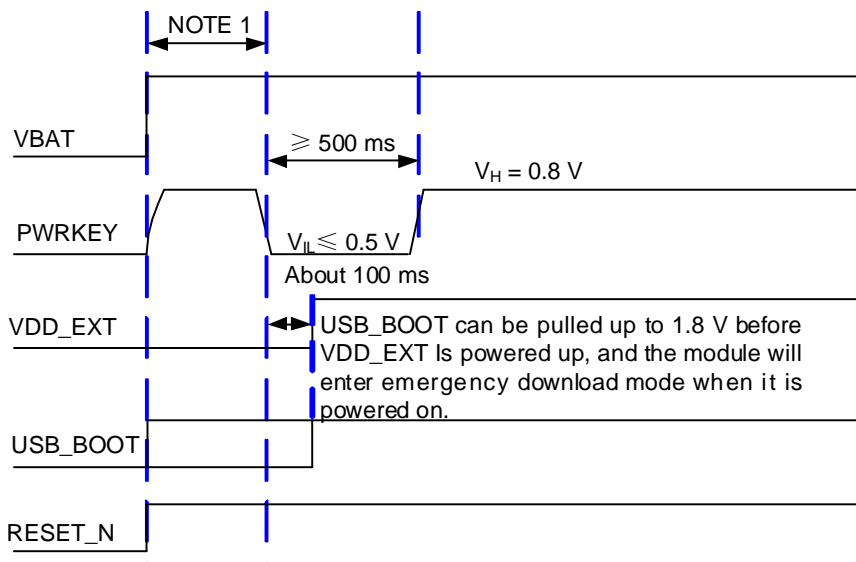

Figure 32: Timing Sequence for Entering Emergency Download Mode

NOTES

1. Please make sure that VBAT is stable before pulling down PWRKEY pin. It is recommended that the time between powering up VBAT and pulling down PWRKEY pin is no less than 30 ms.
2. When using MCU to control module to enter the emergency download mode, please follow the above timing sequence. It is not recommended to pull up USB_BOOT to 1.8 V before powering up VBAT. Connect the test points as shown in **Figure 31** can manually force the module to enter download mode.

4 GNSS Receiver

4.1. General Description

EC25 includes a fully integrated global navigation satellite system solution that supports Gen8C-Lite of Qualcomm (GPS, GLONASS, BeiDou, Galileo and QZSS).

EC25 supports standard NMEA-0183 protocol, and outputs NMEA sentences at 1 Hz data update rate via USB interface by default.

By default, EC25 GNSS engine is switched off. It has to be switched on via AT command. For more details about GNSS engine technology and configurations, please refer to **document [3]**.

4.2. GNSS Performance

The following table shows the GNSS performance of the module.

Table 25: GNSS Performance

Parameter	Description	Conditions	Typ.	Unit
Sensitivity (GNSS)	Cold start	Autonomous	-146	dBm
	Reacquisition	Autonomous	-157	dBm
	Tracking	Autonomous	-157	dBm
TTFF (GNSS)	Cold start @ open sky	Autonomous	35	s
		XTRA enabled	18	s
	Warm start @ open sky	Autonomous	26	s
		XTRA enabled	2.2	s

	Hot start @ open sky	Autonomous	2.5	s
		XTRA enabled	1.8	s
Accuracy (GNSS)	CEP-50	Autonomous @ open sky	<2.5	m

NOTES

1. Tracking sensitivity: the minimum GNSS signal power at which the module can maintain lock (keep positioning for at least 3 minutes continuously).
2. Reacquisition sensitivity: the minimum GNSS signal power required for the module to maintain lock within 3 minutes after loss of lock.
3. Cold start sensitivity: the minimum GNSS signal power at which the module can fix position successfully within 3 minutes after executing cold start command.

4.3. Layout Guidelines

The following layout guidelines should be taken into account in customers' designs.

- Maximize the distance among GNSS antenna, main antenna and Rx-diversity antenna.
- Digital circuits such as (U)SIM card, USB interface, camera module and display connector should be kept away from the antennas.
- Use ground vias around the GNSS trace and sensitive analog signal traces to provide coplanar isolation and protection.
- Keep 50 Ω characteristic impedance for the ANT_GNSS trace.

Please refer to **Chapter 5** for GNSS antenna reference design and antenna installation information.

5 Antenna Interfaces

EC25 antenna interfaces include a main antenna interface, an Rx-diversity antenna interface which is used to resist the fall of signals caused by high speed movement and multipath effect, and a GNSS antenna interface. The antenna ports have an impedance of 50 Ω.

5.1. Main/Rx-diversity Antenna Interfaces

5.1.1. Pin Definition

The pin definition of main antenna and Rx-diversity antenna interfaces is shown below.

Table 26: Pin Definition of RF Antennas

Pin Name	Pin No.	I/O	Description	Comment
ANT_MAIN	49	IO	Main antenna	50 Ω impedance
ANT_DIV	35	AI	Receive diversity antenna	50 Ω impedance. If unused, keep it open.

5.1.2. Operating Frequency

Table 27: Module Operating Frequencies

3GPP Band	Transmit	Receive	Unit
GSM850	824–849	869–894	MHz
EGSM900	880–915	925–960	MHz
DCS1800	1710–1785	1805–1880	MHz
PCS1900	1850–1910	1930–1990	MHz
WCDMA B1	1920–1980	2110–2170	MHz

WCDMA B2	1850–1910	1930–1990	MHz
WCDMA B4	1710–1755	2110–2155	MHz
WCDMA B5	824–849	869–894	MHz
WCDMA B6	830–840	875–885	MHz
WCDMA B8	880–915	925–960	MHz
WCDMA B19	830–845	875–890	MHz
LTE-FDD B1	1920–1980	2110–2170	MHz
LTE-FDD B2	1850–1910	1930–1990	MHz
LTE-FDD B3	1710–1785	1805–1880	MHz
LTE-FDD B4	1710–1755	2110–2155	MHz
LTE-FDD B5	824–849	869–894	MHz
LTE-FDD B7	2500–2570	2620–2690	MHz
LTE-FDD B8	880–915	925–960	MHz
LTE-FDD B12	699–716	729–746	MHz
LTE-FDD B13	777–787	746–756	MHz
LTE-FDD B14	788–798	758–768	MHz
LTE-FDD B18	815–830	860–875	MHz
LTE-FDD B19	830–845	875–890	MHz
LTE-FDD B20	832–862	791–821	MHz
LTE-FDD B26	814–849	859–894	MHz
LTE-FDD B28	703–748	758–803	MHz
LTE-TDD B38	2570–2620	2570–2620	MHz
LTE-TDD B40	2300–2400	2300–2400	MHz
LTE-TDD B41	2555–2655	2555–2655	MHz
LTE-FDD B66	1710–1780	2100–2200	MHz

5.1.3. Reference Design of RF Antenna Interface

A reference design of ANT_MAIN and ANT_DIV antenna pads is shown as below. A π -type matching circuit should be reserved for better RF performance. The capacitors are not mounted by default.

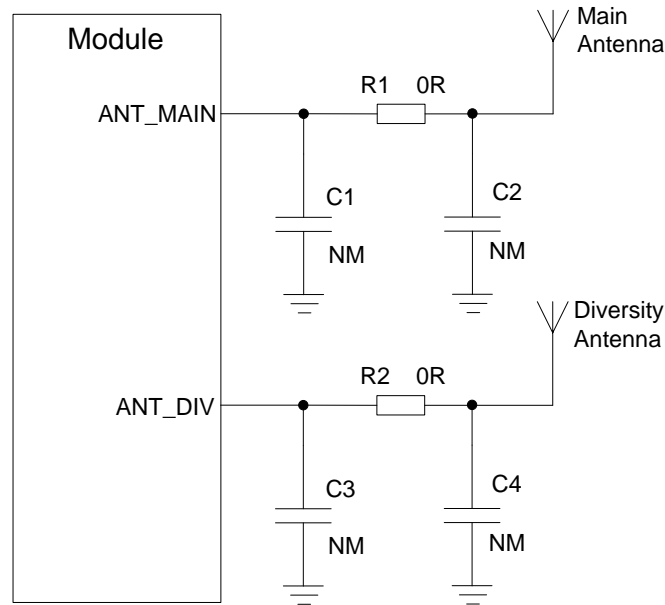

Figure 33: Reference Circuit of RF Antenna Interface

NOTES

1. Keep a proper distance between the main antenna and the Rx-diversity antenna to improve the receiving sensitivity.
2. ANT_DIV function is enabled by default. `AT+QCFG="divctl",0` command can be used to disable receive diversity. Please refer to **document [2]** for details.
3. Place the π -type matching components (R1 & C1 & C2, R2 & C3 & C4) as close to the antenna as possible.

5.1.4. Reference Design of RF Layout

For user's PCB, the characteristic impedance of all RF traces should be controlled as 50 Ω . The impedance of the RF traces is usually determined by the trace width (W), the materials' dielectric constant, height from the reference ground to the signal layer (H), and the space between the RF trace and the ground (S). Microstrip and coplanar waveguide are typically used in RF layout to control characteristic impedance. The following figures are reference designs of microstrip or coplanar waveguide with different PCB structures.

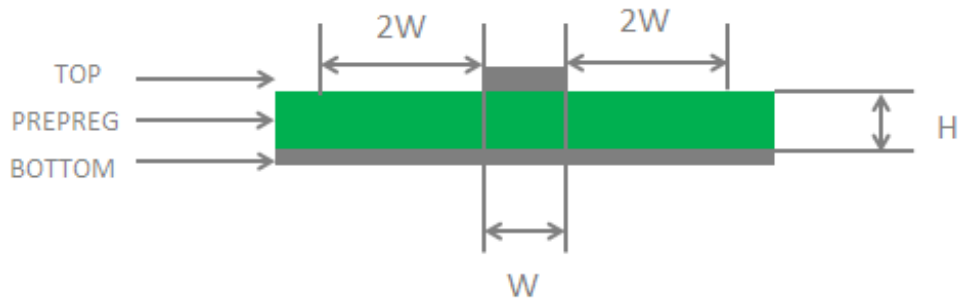

Figure 34: Microstrip Design on a 2-layer PCB

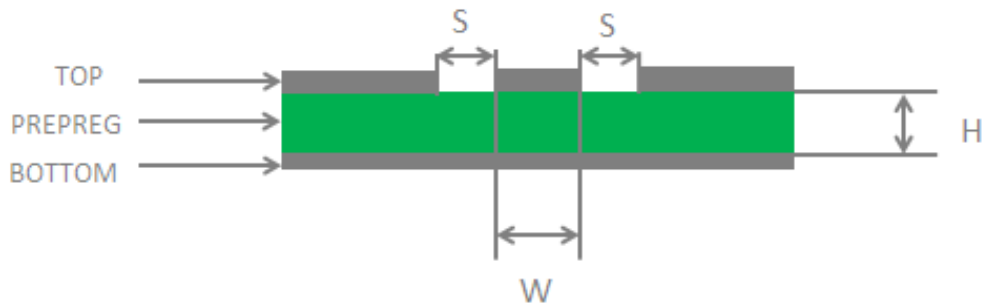

Figure 35: Coplanar Waveguide Design on a 2-layer PCB

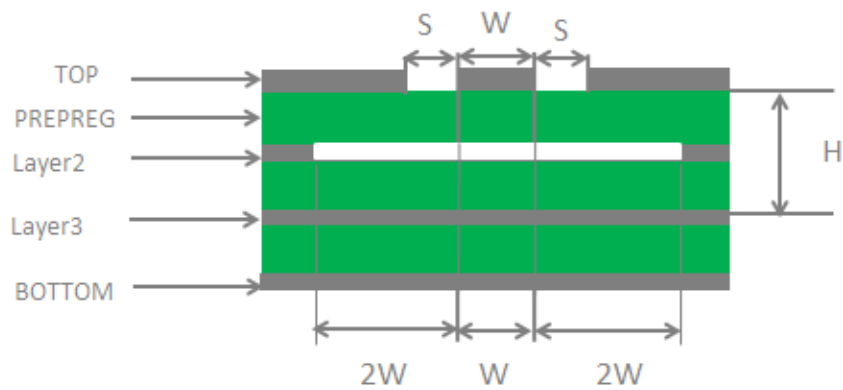

Figure 36: Coplanar Waveguide Design on a 4-layer PCB (Layer 3 as Reference Ground)

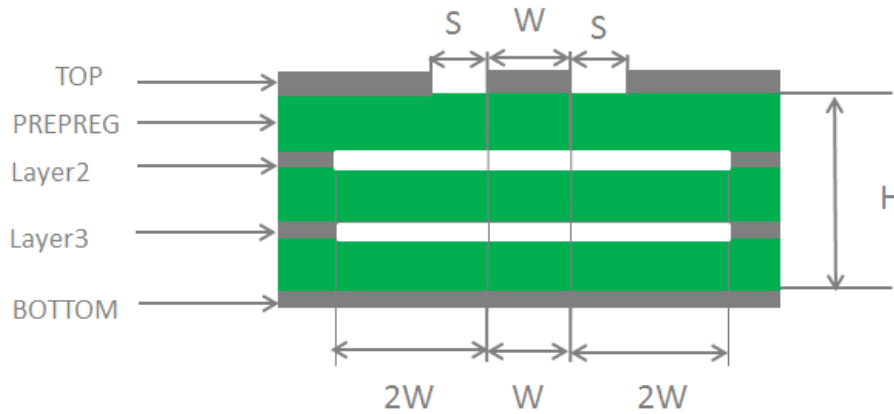

Figure 37: Coplanar Waveguide Design on a 4-layer PCB (Layer 4 as Reference Ground)

In order to ensure RF performance and reliability, the following principles should be complied with in RF layout design:

- Please use an impedance simulation tool to control the characteristic impedance of RF traces as 50 Ω.
- The GND pins adjacent to RF pins should not be designed as thermal relief pads, and should be fully connected to ground.
- The distance between the RF pins and the RF connector should be as short as possible, and all the right angle traces should be changed to curved ones.
- There should be clearance area under the signal pin of the antenna connector or solder joint.
- The reference ground of RF traces should be complete. Meanwhile, adding some ground vias around RF traces and the reference ground could help to improve RF performance. The distance between the ground vias and RF traces should be no less than two times the width of RF signal traces (2 × W).

For more details about RF layout, please refer to **document [6]**.

5.2. GNSS Antenna Interface

The following tables show the pin definition and frequency specification of GNSS antenna interface.

Table 28: Pin Definition of GNSS Antenna Interface

Pin Name	Pin No.	I/O	Description	Comment
ANT_GNSS	47	AI	GNSS antenna	50 Ω impedance. If unused, keep it open.

Table 29: GNSS Frequency

Type	Frequency	Unit
GPS	1575.42 ±1.023	MHz
GLONASS	1597.5–1605.8	MHz
Galileo	1575.42 ±2.046	MHz
BeiDou (Compass)	1561.098 ±2.046	MHz
QZSS	1575.42	MHz

A reference design of GNSS antenna is shown as below.

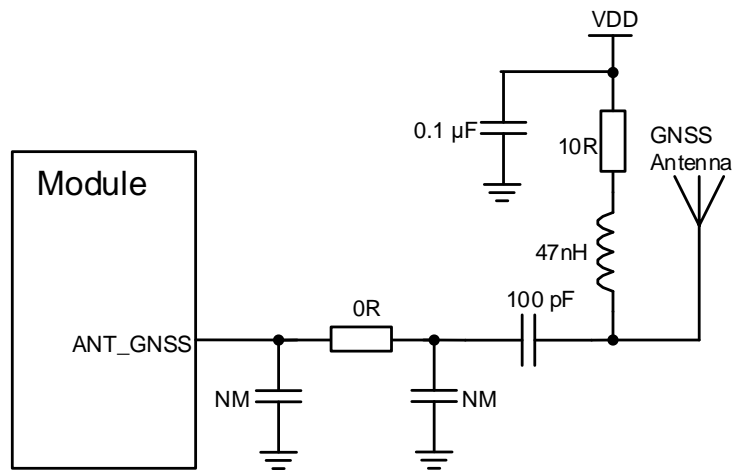

Figure 38: Reference Circuit of GNSS Antenna

NOTES

1. An external LDO can be selected to supply power according to the active antenna requirement.
2. If the module is designed with a passive antenna, then the VDD circuit is not needed.

5.3. Antenna Installation

5.3.1. Antenna Requirement

The following table shows the requirements on main antenna, Rx-diversity antenna and GNSS antenna.

Table 30: Antenna Requirements

Type	Requirements
GNSS ¹⁾	Frequency range: 1559–1609 MHz Polarization: RHCP or linear VSWR: < 2 (Typ.) Passive antenna gain: > 0 dBi Active antenna noise figure: < 1.5 dB Active antenna gain: > 0 dBi Active antenna embedded LNA gain: < 17 dB
GSM/WCDMA/LTE	VSWR: ≤ 2 Efficiency: > 30% Max input power: 50 W Input impedance: 50 Ω Cable insertion loss: < 1 dB (GSM850, EGSM900, WCDMA B5/B6/B8/B19, LTE-FDD B5/B8/B12/B13/B14/B18/B19/B20/B26/B28/B71) Cable insertion loss: < 1.5 dB (DCS1800, PCS1900, WCDMA B1/B2/B4, LTE-FDD B1/B2/B3/B4/B66) Cable insertion loss: < 2 dB (LTE-FDD B7, LTE-TDD B38/B40/B41)

NOTE

¹⁾ It is recommended to use a passive GNSS antenna when LTE B13 or B14 is supported, as the use of active antenna may generate harmonics which will affect the GNSS performance.

5.3.2. Recommended RF Connector for Antenna Installation

If RF connector is used for antenna connection, it is recommended to use U.FL-R-SMT connector provided by Hirose.

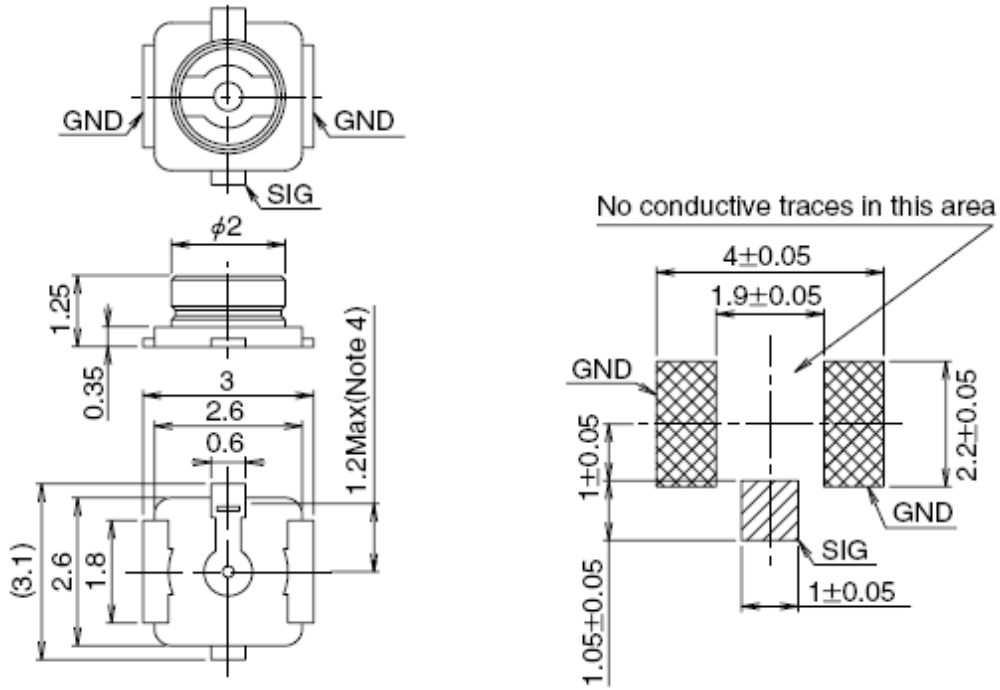

Figure 39: Dimensions of the U.FL-R-SMT Connector (Unit: mm)

U.FL-LP serial connectors listed in the following figure can be used to match the U.FL-R-SMT.

	U.FL-LP-040	U.FL-LP-066	U.FL-LP(V)-040	U.FL-LP-062	U.FL-LP-088
Part No.					
Mated Height	2.5mm Max. (2.4mm Nom.)	2.5mm Max. (2.4mm Nom.)	2.0mm Max. (1.9mm Nom.)	2.4mm Max. (2.3mm Nom.)	2.4mm Max. (2.3mm Nom.)
Applicable cable	Dia. 0.81mm Coaxial cable	Dia. 1.13mm and Dia. 1.32mm Coaxial cable	Dia. 0.81mm Coaxial cable	Dia. 1mm Coaxial cable	Dia. 1.37mm Coaxial cable
Weight (mg)	53.7	59.1	34.8	45.5	71.7
RoHS	YES				

Figure 40: Mechanicals of U.FL-LP Connectors

The following figure describes the space factor of mated connector.

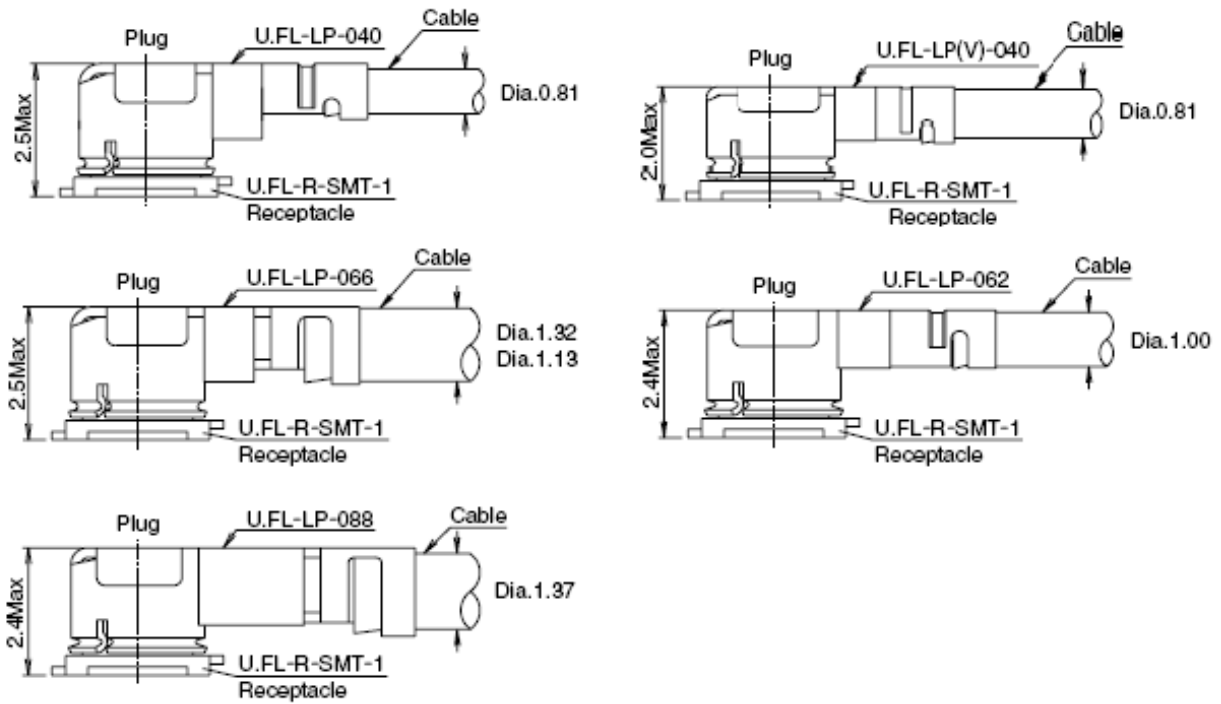

Figure 41: Space Factor of Mated Connector (Unit: mm)

For more details, please visit <http://www.hirose.com>.

6 Electrical, Reliability and Radio Characteristics

6.1. Absolute Maximum Ratings

Absolute maximum ratings for power supply and voltage on digital and analog pins of the module are listed in the following table.

Table 31: Absolute Maximum Ratings

Parameter	Min.	Max.	Unit
VBAT_RF/VBAT_BB	-0.3	4.7	V
USB_VBUS	-0.3	5.5	V
Peak Current of VBAT_BB	0	0.8	A
Peak Current of VBAT_RF	0	1.8	A
Voltage at Digital Pins	-0.3	2.3	V
Voltage at ADC0	0	VBAT_BB	V
Voltage at ADC1	0	VBAT_BB	V

6.2. Power Supply Ratings

Table 32: Power Supply Ratings

Parameter	Description	Conditions	Min.	Typ.	Max.	Unit
VBAT	VBAT_BB and VBAT_RF	The actual input voltages must be kept between the minimum and maximum values.	3.3	3.8	4.3	V
	Voltage drop during burst transmission	Maximum power control level on EGSM900.			400	mV
I _{VBAT}	Peak supply current (during transmission slot)	Maximum power control level on EGSM900.		1.8	2.0	A
USB_VBUS	USB connection detection		3.0	5.0	5.25	V

6.3. Operating and Storage Temperatures

The operating and storage temperatures are listed in the following table.

Table 33: Operating and Storage Temperatures

Parameter	Min.	Typ.	Max.	Unit
Operating Temperature Range ¹⁾	-35	+25	+75	°C
Extended Temperature Range ²⁾	-40		+85	°C
Storage Temperature Range	-40		+90	°C

NOTES

- ¹⁾ Within operating temperature range, the module is 3GPP compliant.
- ²⁾ Within extended temperature range, the module remains the ability to establish and maintain a voice, SMS, data transmission, etc. There is no unrecoverable malfunction. There are also no effects on radio spectrum and no harm to radio network. Only one or more parameters like P_{out} might reduce in their value and exceed the specified tolerances. When the temperature returns to the normal

operating temperature levels, the module will meet 3GPP specifications again.

3. “*” means under development.

6.4. Current Consumption

The values of current consumption are shown below.

Table 34: EC25-E Current Consumption

Parameter	Description	Conditions	Typ.	Unit
I _{VBAT}	OFF state	Power down	11	μA
		AT+CFUN=0 (USB disconnected)	1.16	mA
	Sleep state	GSM DRX = 2 (USB disconnected)	2.74	mA
		GSM DRX = 9 (USB disconnected)	2.00	mA
		WCDMA PF = 64 (USB disconnected)	2.15	mA
		WCDMA PF = 128 (USB disconnected)	1.67	mA
		LTE-FDD PF = 64 (USB disconnected)	2.60	mA
		LTE-FDD PF = 128 (USB disconnected)	1.90	mA
		LTE-TDD PF = 64 (USB disconnected)	2.79	mA
		LTE-TDD PF = 128 (USB disconnected)	2.00	mA
		GSM DRX = 5 (USB disconnected)	19.5	mA
		GSM DRX = 5 (USB connected)	29.5	mA
	Idle state	WCDMA PF = 64 (USB disconnected)	21.0	mA
		WCDMA PF = 64 (USB connected)	31.0	mA
		LTE-FDD PF = 64 (USB disconnected)	20.7	mA
		LTE-FDD PF = 64 (USB connected)	30.8	mA
		LTE-TDD PF = 64 (USB disconnected)	20.8	mA

	LTE-TDD PF = 64 (USB connected)	32.0	mA
GPRS data transfer (GNSS OFF)	EGSM900 4DL/1UL @ 33.22 dBm	271.0	mA
	EGSM900 3DL/2UL @ 33.0 dBm	464.0	mA
	EGSM900 2DL/3UL @ 30.86 dBm	524.0	mA
	EGSM900 1DL/4UL @ 29.58 dBm	600.0	mA
	DCS1800 4DL/1UL @ 29.92 dBm	192.0	mA
	DCS1800 3DL/2UL @ 29.84 dBm	311.0	mA
	DCS1800 2DL/3UL @ 29.67 dBm	424.0	mA
EDGE data transfer (GNSS OFF)	DCS1800 1DL/4UL @ 29.48 dBm	539.0	mA
	EGSM900 4DL/1UL PCL = 8 @ 27.40 dBm	174.0	mA
	EGSM900 3DL/2UL PCL = 8 @ 27.24 dBm	281.0	mA
	EGSM900 2DL/3UL PCL = 8 @ 27.11 dBm	379.0	mA
	EGSM900 1DL/4UL PCL = 8 @ 26.99 dBm	480.0	mA
WCDMA data transfer (GNSS OFF)	DCS1800 4DL/1UL PCL = 2 @ 25.82 dBm	159.0	mA
	DCS1800 3DL/2UL PCL = 2 @ 25.85 dBm	251.0	mA
	DCS1800 2DL/3UL PCL = 2 @ 25.68 dBm	340.0	mA
	DCS1800 1DL/4UL PCL = 2 @ 25.57 dBm	433.0	mA
	WCDMA B1 HSDPA @ 22.47 dBm	613.0	mA
WCDMA data transfer (GNSS OFF)	WCDMA B1 HSUPA @ 22.44 dBm	609.0	mA
	WCDMA B5 HSDPA @ 23.07 dBm	671.0	mA
	WCDMA B5 HSUPA @ 23.07 dBm	669.0	mA
	WCDMA B8 HSDPA @ 22.67 dBm	561.0	mA
	WCDMA B8 HSUPA @ 22.39 dBm	557.0	mA
LTE data transfer (GNSS OFF)	LTE-FDD B1 @ 23.27 dBm	754.0	mA
	LTE-FDD B3 @ 23.54 dBm	774.0	mA

	LTE-FDD B5 @ 22.83 dBm	762.0	mA
	LTE-FDD B7 @ 23.37 dBm	842.0	mA
	LTE-FDD B8 @ 23.48 dBm	720.0	mA
	LTE-FDD B20 @ 22.75 dBm	714.0	mA
	LTE-TDD B38 @ 23.05 dBm	481.0	mA
	LTE-TDD B40 @ 23.17 dBm	431.8	mA
	LTE-TDD B41 @ 23.02 dBm	480.0	mA
GSM voice call	EGSM900 PCL = 5 @ 33.08 dBm	264.0	mA
	DCS1800 PCL = 0 @ 29.75 dBm	190.0	mA
WCDMA voice call	WCDMA B1 @ 23.22 dBm	680.0	mA
	WCDMA B5 @ 23.18 dBm	677.0	mA
	WCDMA B8 @ 23.54 dBm	618.0	mA

Table 35: EC25-EX Current Consumption

Parameter	Description	Conditions	Typ.	Unit	
I _{BAT}	OFF state	Power down	7	μA	
	Sleep state	AT+CFUN=0 (USB disconnected)		0.71	mA
		GSM DRX = 2 (USB disconnected)		1.51	mA
		GSM DRX = 9 (USB disconnected)		0.94	mA
		DCS 698 DRX = 2 (USB disconnected)		1.58	mA
		DCS 698 DRX = 9 (USB disconnected)		1.01	mA
		WCDMA PF = 64 (USB disconnected)		1.41	mA
		WCDMA PF = 128 (USB disconnected)		1.11	mA
		LTE-FDD PF = 64 (USB disconnected)		1.82	mA
		LTE-FDD PF = 128 (USB disconnected)		1.32	mA

Idle state	LTE-TDD PF = 64 (USB disconnected)	1.95	mA	
	LTE-TDD PF = 128 (USB disconnected)	1.39	mA	
	GSM DRX = 5 (USB disconnected)	15.37	mA	
	GSM DRX = 5 (USB connected)	24.83	mA	
	WCDMA PF = 64 (USB disconnected)	15.68	mA	
	WCDMA PF = 64 (USB connected)	25.02	mA	
	LTE-FDD PF = 64 (USB disconnected)	14.71	mA	
	LTE-FDD PF = 64 (USB connected)	23.87	mA	
	LTE-TDD PF = 64 (USB disconnected)	14.66	mA	
	LTE-TDD PF = 64 (USB connected)	23.97	mA	
	GPRS data transfer (GNSS OFF)	EGSM900 4DL/1UL @ 32.15 dBm	216.8	mA
		EGSM900 3DL/2UL @ 30.88 dBm	359.1	mA
EGSM900 2DL/3UL @ 29.15 dBm		451.7	mA	
EGSM900 1DL/4UL @ 28.7 dBm		570.3	mA	
DCS1800 4DL/1UL @ 28.90 dBm		152.0	mA	
DCS1800 3DL/2UL @ 28.28 dBm		262.5	mA	
DCS1800 2DL/3UL @ 26.85 dBm		357.6	mA	
DCS1800 1DL/4UL @ 25.74 dBm		454.1	mA	
EDGE data transfer (GNSS OFF)	EGSM900 4DL/1UL PCL = 8 @ 25.86 dBm	159.5	mA	
	EGSM900 3DL/2UL PCL = 8 @ 24.69 dBm	270.5	mA	
	EGSM900 2DL/3UL PCL = 8 @ 22.96 dBm	386.6	mA	
	EGSM900 1DL/4UL PCL = 8 @ 22.26 dBm	500.1	mA	
	DCS1800 4DL/1UL PCL = 2 @ 25.23 dBm	138.6	mA	
	DCS1800 3DL/2UL PCL = 2 @ 24.69 dBm	245.6	mA	
	DCS1800 2DL/3UL PCL = 2 @ 22.01 dBm	345.8	mA	

		DCS1800 1DL/4UL PCL = 2 @ 21.32 dBm	444.3	mA
WCDMA data transfer (GNSS OFF)		WCDMA B1 HSDPA @ 22.08 dBm	504.0	mA
		WCDMA B1 HSUPA @ 21.46 dBm	498.4	mA
		WCDMA B5 HSDPA @ 22.65 dBm	531.9	mA
		WCDMA B5 HSUPA @ 22.36 dBm	500.4	mA
		WCDMA B8 HSDPA @ 22.13 dBm	544.5	mA
		WCDMA B8 HSUPA @ 21.12 dBm	504.1	mA
	LTE data transfer (GNSS OFF)		LTE-FDD B1 @ 22.38 dBm	622.8
		LTE-FDD B3 @ 22.31 dBm	666.0	mA
		LTE-FDD B5 @ 22.77 dBm	549.9	mA
		LTE-FDD B7 @ 22.31 dBm	740.8	mA
		LTE-FDD B8 @ 22.69 dBm	631.5	mA
		LTE-FDD B20 @ 22.84dBm	741.5	mA
		LTE-TDD B38 @ 22.11 dBm	334.1	mA
		LTE-TDD B40 @ 22.33 dBm	390.2	mA
GSM voice call		EGSM900 PCL = 5 @ 31.79 dBm	228.1	mA
		DCS1800 PCL = 0 @ 28.96 dBm	166.7	mA
WCDMA voice call		WCDMA B1 @ 22.23 dBm	512.3	mA
		WCDMA B5 @ 22.88 dBm	546.3	mA
		WCDMA B8 @ 22.32 dBm	567.1	mA

Table 36: EC25-A Current Consumption

Parameter	Description	Conditions	Typ.	Unit
I _{BAT}	OFF state	Power down	10	μA

	AT+CFUN=0 (USB disconnected)	1.1	mA
	WCDMA PF = 64 (USB disconnected)	1.8	mA
Sleep state	WCDMA PF = 128 (USB disconnected)	1.5	mA
	LTE-FDD PF = 64 (USB disconnected)	2.2	mA
	LTE-FDD PF = 128 (USB disconnected)	1.6	mA
	WCDMA PF = 64 (USB disconnected)	21.0	mA
	WCDMA PF = 64 (USB connected)	31.0	mA
Idle state	LTE-FDD PF = 64 (USB disconnected)	21.0	mA
	LTE-FDD PF = 64 (USB connected)	31.0	mA
	WCDMA B2 HSDPA @ 21.9 dBm	591.0	mA
WCDMA data transfer (GNSS OFF)	WCDMA B2 HSUPA @ 21.62 dBm	606.0	mA
	WCDMA B4 HSDPA @ 22.02 dBm	524.0	mA
	WCDMA B4 HSUPA @ 21.67 dBm	540.0	mA
	WCDMA B5 HSDPA @ 22.71 dBm	490.0	mA
	WCDMA B5 HSUPA @ 22.58 dBm	520.0	mA
	LTE-FDD B2 @ 22.93 dBm	715.0	mA
LTE data transfer (GNSS OFF)	LTE-FDD B4 @ 22.96 dBm	738.0	mA
	LTE-FDD B12 @ 23.35 dBm	663.0	mA
	WCDMA B2 @ 22.93 dBm	646.0	mA
WCDMA voice call	WCDMA B4 @ 23 dBm	572.0	mA
	WCDMA B5 @ 23.78 dBm	549.0	mA

Table 37: EC25-V Current Consumption

Parameter	Description	Conditions	Typ.	Unit
I _{BAT}	OFF state	Power down	10	μA

Sleep state	AT+CFUN=0 (USB disconnected)	0.85	mA
	LTE-FDD PF = 64 (USB disconnected)	2.0	mA
	LTE-FDD PF = 128 (USB disconnected)	1.5	mA
Idle state	LTE-FDD PF = 64 (USB disconnected)	20.0	mA
	LTE-FDD PF = 64 (USB connected)	31.0	mA
LTE data transfer (GNSS OFF)	LTE-FDD B4 @ 23.14 dBm	770.0	mA
	LTE-FDD B13 @ 23.48 dBm	531.0	mA

Table 38: EC25-J Current Consumption

Parameter	Description	Conditions	Typ.	Unit
I _{VBAT}	OFF state	Power down	10	μA
	Sleep state	AT+CFUN=0 (USB disconnected)	1.1	mA
		WCDMA PF = 64 (USB disconnected)	1.9	mA
		WCDMA PF = 128 (USB disconnected)	1.5	mA
		LTE-FDD PF = 64 (USB disconnected)	2.5	mA
		LTE-FDD PF = 128 (USB disconnected)	1.8	mA
		LTE-TDD PF = 64 (USB disconnected)	2.6	mA
	Idle state	LTE-TDD PF = 128 (USB disconnected)	1.9	mA
		WCDMA PF = 64 (USB disconnected)	21.0	mA
		WCDMA PF = 64 (USB connected)	31.0	mA
		LTE-FDD PF = 64 (USB disconnected)	21.0	mA
		LTE-FDD PF = 64 (USB connected)	32.0	mA
		LTE-TDD PF = 64 (USB disconnected)	21.0	mA
	WCDMA data	LTE-TDD PF = 64 (USB connected)	32.0	mA
		WCDMA B1 HSDPA @ 22.32 dBm	549.0	mA

transfer (GNSS OFF)	WCDMA B1 HSUPA @ 21.79 dBm	533.0	mA
	WCDMA B6 HSDPA @ 22.64 dBm	515.0	mA
	WCDMA B6 HSUPA @ 22.33 dBm	520.0	mA
	WCDMA B19 HSDPA @ 22.67 dBm	516.0	mA
	WCDMA B19 HSUPA @ 22.33 dBm	521.0	mA
LTE data transfer (GNSS OFF)	LTE-FDD B1 @ 23.16 dBm	685.0	mA
	LTE-FDD B3 @ 23.22 dBm	765.0	mA
	LTE-FDD B8 @ 23.22 dBm	640.0	mA
	LTE-FDD B18 @ 23.35 dBm	660.0	mA
	LTE-FDD B19 @ 23.16 dBm	676.0	mA
	LTE-FDD B26 @ 22.87 dBm	689.0	mA
	LTE-TDD B41 @ 22.52 dBm	438.0	mA
WCDMA voice call	WCDMA B1 @ 23.33 dBm	604.0	mA
	WCDMA B6 @ 23.28 dBm	548.0	mA
	WCDMA B19 @ 23.28 dBm	548.0	mA

Table 39: EC25-JL Current Consumption

Parameter	Description	Conditions	Typ.	Unit
I _{VBAT}	OFF state	Power down	10	μA
		AT+CFUN=0 (USB disconnected)	1.1	mA
		LTE-FDD PF = 64 (USB disconnected)	2.5	mA
	Sleep state	LTE-FDD PF = 128 (USB disconnected)	1.8	mA
		LTE-TDD PF = 64 (USB disconnected)	2.6	mA
		LTE-TDD PF = 128 (USB disconnected)	1.9	mA
	Idle state	LTE-FDD PF = 64 (USB disconnected)	21.0	mA

	LTE-FDD PF = 64 (USB connected)	32.0	mA
	LTE-TDD PF = 64 (USB disconnected)	21.0	mA
	LTE-TDD PF = 64 (USB connected)	32.0	mA
LTE data transfer (GNSS OFF)	LTE-FDD B1 @ 23.16 dBm	685.0	mA
	LTE-FDD B3 @ 23.22 dBm	765.0	mA
	LTE-FDD B8 @ 23.22 dBm	640.0	mA
	LTE-FDD B18 @ 23.35 dBm	660.0	mA
	LTE-FDD B19 @ 23.16 dBm	676.0	mA
	LTE-FDD B26 @ 22.87 dBm	689.0	mA
	LTE-TDD B41 @ 22.52 dBm	438.0	mA

Table 40: EC25-AU Current Consumption

Parameter	Description	Conditions	Typ.	Unit
I _{V_{BAT}}	OFF state	Power down	11	μA
		AT+CFUN=0	1.3	mA
		AT+CFUN=0 (USB disconnected)	1.46	mA
		GSM850 DRX = 5 (USB disconnected)	1.8	mA
		EGSM900 DRX = 5 (USB disconnected)	2.0	mA
		DCS1800 DRX = 5 (USB disconnected)	1.9	mA
	Sleep state	PCS1900 DRX = 5 (USB disconnected)	1.9	mA
		WCDMA PF = 64 (USB disconnected)	2.0	mA
		WCDMA PF = 128 (USB disconnected)	1.6	mA
		LTE-FDD PF = 64 (USB disconnected)	2.2	mA
		LTE-FDD PF = 128 (USB disconnected)	1.6	mA
		LTE-TDD PF = 64 (USB disconnected)	2.3	mA

	LTE-TDD PF = 128 (USB disconnected)	1.6	mA
	EGSM900 DRX = 5 (USB disconnected)	22.0	mA
	EGSM900 DRX = 5 (USB connected)	34.0	mA
Idle state	WCDMA PF = 64 (USB disconnected)	22.0	mA
	WCDMA PF = 64 (USB connected)	33.0	mA
	LTE-FDD PF = 64 (USB disconnected)	24.0	mA
	LTE-FDD PF = 64 (USB connected)	35.0	mA
	GSM850 1UL/4DL @ 32.53 dBm	232.0	mA
	GSM850 2UL/3DL @ 32.34 dBm	384.0	mA
	GSM850 3UL/2DL @ 30.28 dBm	441.0	mA
	GSM850 4UL/1DL @ 29.09 dBm	511.0	mA
	EGSM900 1UL/4DL @ 32.34 dBm	241.0	mA
	EGSM900 2UL/3DL @ 32.19 dBm	397.0	mA
	EGSM900 3UL/2DL @ 30.17 dBm	459.0	mA
GPRS data transfer (GNSS OFF)	EGSM900 4UL/1DL @ 28.96 dBm	533.0	mA
	DCS1800 1UL/4DL @ 29.71 dBm	183.0	mA
	DCS1800 2UL/3DL @ 29.62 dBm	289.0	mA
	DCS1800 3UL/2DL @ 29.49 dBm	392.0	mA
	DCS1800 4UL/1DL @ 29.32 dBm	495.0	mA
	PCS1900 1UL/4DL @ 29.61 dBm	174.0	mA
	PCS1900 2UL/3DL @ 29.48 dBm	273.0	mA
	PCS1900 3UL/2DL @ 29.32 dBm	367.0	mA
	PCS1900 4UL/1DL @ 29.19 dBm	465.0	mA
	EDGE data transfer (GNSS OFF)	GSM850 1UL/4DL @ 27.09 dBm	154.0
GSM850 2UL/3DL @ 26.94 dBm		245.0	mA

	GSM850 3UL/2DL @ 26.64 dBm	328.0	mA
	GSM850 4UL/1DL @ 26.53 dBm	416.0	mA
	EGSM900 1UL/4DL @ 26.64 dBm	157.0	mA
	EGSM900 2UL/3DL @ 26.95 dBm	251.0	mA
	EGSM900 3UL/2DL @ 26.57 dBm	340.0	mA
	EGSM900 4UL/1DL @ 26.39 dBm	431.0	mA
	DCS1800 1UL/4DL @ 26.03 dBm	152.0	mA
	DCS1800 2UL/3DL @ 25.62 dBm	240.0	mA
	DCS1800 3UL/2DL @ 25.42 dBm	325.0	mA
	DCS1800 4UL/1DL @ 25.21 dBm	415.0	mA
	PCS1900 1UL/4DL @ 25.65 dBm	148.0	mA
	PCS1900 2UL/3DL @ 25.63 dBm	232.0	mA
	PCS1900 3UL/2DL @ 25.54 dBm	313.0	mA
	PCS1900 4UL/1DL @ 25.26 dBm	401.0	mA
	WCDMA B1 HSDPA @ 22.34 dBm	625.0	mA
	WCDMA B1 HSUPA @ 21.75 dBm	617.0	mA
	WCDMA B2 HSDPA @ 22.51 dBm	610.0	mA
WCDMA data transfer (GNSS OFF)	WCDMA B2 HSUPA @ 22. 14 dBm	594.0	mA
	WCDMA B5 HSDPA @ 22.98 dBm	576.0	mA
	WCDMA B5 HSUPA @ 22.89 dBm	589.0	mA
	WCDMA B8 HSDPA @ 22.31 dBm	556.0	mA
	WCDMA B8 HSUPA @ 22.11 dBm	572.0	mA
LTE data transfer (GNSS OFF)	LTE-FDD B1 @ 23.28 dBm	817.0	mA
	LTE-FDD B2 @ 23.34 dBm	803.0	mA
	LTE-FDD B3 @ 23.2 dBm	785.0	mA

	LTE-FDD B4 @ 22.9 dBm	774.0	mA
	LTE-FDD B5 @ 23.45 dBm	687.0	mA
	LTE-FDD B7 @ 22.84 dBm	843.0	mA
	LTE-FDD B8 @ 22.92 dBm	689.0	mA
	LTE-FDD B28 @ 23.23 dBm	804.0	mA
	LTE-TDD B40 @ 23.3 dBm	429.0	mA
GSM voice call	GSM850 PCL5 @ 32.66 dBm	228.0	mA
	EGSM900 PCL5 @ 32.59 dBm	235.0	mA
	DCS1800 PCL0 @ 29.72 dBm	178.0	mA
	PCS1900 PCL0 @ 29.82 dBm	170.0	mA
WCDMA voice call	WCDMA B1 @ 23.27 dBm	687.0	mA
	WCDMA B2 @ 23.38 dBm	668.0	mA
	WCDMA B5 @ 23.38 dBm	592.0	mA
	WCDMA B8 @ 23.32 dBm	595.0	mA

Table 41: EC25-AUT Current Consumption

Parameter	Description	Conditions	Typ.	Unit	
I _V BAT	OFF state	Power down	10	μA	
	Sleep state		AT+CFUN=0 (USB disconnected)	1.0	mA
			WCDMA PF = 64 (USB disconnected)	1.9	mA
			WCDMA PF = 128 (USB disconnected)	1.5	mA
			LTE-FDD PF = 64 (USB disconnected)	2.3	mA
	Idle state		LTE-FDD PF = 128 (USB disconnected)	1.9	mA
			WCDMA PF = 64 (USB disconnected)	23.0	mA
			WCDMA PF = 64 (USB connected)	33.0	mA
			LTE-FDD PF = 64 (USB disconnected)	17.0	mA

	LTE-FDD PF = 64 (USB connected)	29.0	mA
WCDMA data transfer (GNSS OFF)	WCDMA B1 HSDPA @ 22.24 dBm	500.0	mA
	WCDMA B1 HSUPA @ 22.05 dBm	499.0	mA
	WCDMA B5 HSDPA @ 22.39 dBm	418.0	mA
	WCDMA B5 HSUPA @ 22 dBm	486.0	mA
LTE data transfer (GNSS OFF)	LTE-FDD B1 @ 23.28 dBm	707.0	mA
	LTE-FDD B3 @ 23.36 dBm	782.0	mA
	LTE-FDD B5 @ 23.32 dBm	588.0	mA
	LTE-FDD B7 @ 23.08 dBm	692.0	mA
	LTE-FDD B28A @ 23.37 dBm	752.0	mA
	LTE-FDD B28B @ 23.48 dBm	770.0	mA
WCDMA voice call	WCDMA B1 @ 23.22 dBm	546.0	mA
	WCDMA B5 @ 23.01 dBm	511.0	mA

Table 42: EC25-AF Current Consumption

Parameter	Description	Conditions	Typ.	Unit
I _{VBAT}	OFF state	Power down	10	μA
		AT+CFUN=0 (USB disconnected)	1.0	mA
	Sleep state	WCDMA PF = 64 (USB disconnected)	1.8	mA
		WCDMA PF = 128 (USB disconnected)	1.4	mA
		LTE-FDD PF = 64 (USB disconnected)	2.2	mA
		LTE-FDD PF = 128 (USB disconnected)	1.8	mA
	Idle state	WCDMA PF = 64 (USB disconnected)	23.3	mA
		WCDMA PF = 64 (USB connected)	33.4	mA
		LTE-FDD PF = 64 (USB disconnected)	17.6	mA

	LTE-FDD PF = 64 (USB connected)	29.4	mA
WCDMA data transfer (GNSS OFF)	WCDMA B2 HSDPA @ 22.63 dBm	560.0	mA
	WCDMA B2 HSUPA @ 22.49 dBm	564.0	mA
	WCDMA B4 HSDPA @ 22.45 dBm	601.0	mA
	WCDMA B4 HSUPA @ 22.57 dBm	610.0	mA
	WCDMA B5 HSDPA @ 22.49 dBm	603.0	mA
	WCDMA B5 HSUPA @ 22.43 dBm	617.0	mA
	LTE data transfer (GNSS OFF)	LTE-FDD B2 @ 22.92 dBm	698.0
LTE-FDD B4 @ 23.12 dBm		710.0	mA
LTE-FDD B5 @ 22.98 dBm		650.0	mA
LTE-FDD B12 @ 23.42 dBm		648.0	mA
LTE-FDD B13 @ 22.92 dBm		690.0	mA
LTE-FDD B14 @ 23.42 dBm		685.0	mA
LTE-FDD B66 @ 23.35 dBm		715.0	mA
WCDMA voice call	LTE-FDD B71 @ 23.39 dBm	689.0	mA
	WCDMA B2 @ 23.59 dBm	585.0	mA
	WCDMA B4 @ 23.47 dBm	610.0	mA
	WCDMA B5 @ 23.46 dBm	605.0	mA

Table 43: EC25-AFX Current Consumption

Parameter	Description	Conditions	Typ.	Unit
I _{BAT}	OFF state	Power down	8	μA
		AT+CFUN=0 (USB disconnected)	0.83	mA
	Sleep state	WCDMA PF = 64 (USB disconnected)	1.55	mA
		WCDMA PF = 128 (USB disconnected)	1.24	mA

	WCDMA PF = 256 (USB disconnected)	1.07	mA
	WCDMA PF = 512 (USB disconnected)	1.00	mA
	LTE-FDD PF = 32 (USB disconnected)	2.97	mA
	LTE-FDD PF = 64 (USB disconnected)	1.93	mA
	LTE-FDD PF = 128 (USB disconnected)	1.43	mA
	LTE-FDD PF = 256 (USB disconnected)	1.17	mA
Idle state	WCDMA PF = 64 (USB disconnected)	14.9	mA
	WCDMA PF = 64 (USB connected)	34.2	mA
	LTE-FDD PF = 64 (USB disconnected)	15.2	mA
	LTE-FDD PF = 64 (USB connected)	34.8	mA
WCDMA data transfer (GNSS OFF)	WCDMA B2 HSDPA @ 22.1 dBm	548.0	mA
	WCDMA B2 HSUPA @ 22.28 dBm	545.0	mA
	WCDMA B4 HSDPA @ 22.2 dBm	580.0	mA
	WCDMA B4 HSUPA @ 22.2 dBm	596.0	mA
	WCDMA B5 HSDPA @ 22.1 dBm	498.0	mA
	WCDMA B5 HSUPA @ 22.0 dBm	500.0	mA
LTE data transfer (GNSS OFF)	LTE-FDD B2 @ 23.36 dBm	621.0	mA
	LTE-FDD B4 @ 22.7 dBm	702.0	mA
	LTE-FDD B5 @ 22.7 dBm	564.0	mA
	LTE-FDD B12 @ 22.66 dBm	648.0	mA
	LTE-FDD B13 @ 22.79 dBm	617.0	mA
	LTE-FDD B14 @ 22.72 dBm	622.0	mA
	LTE-FDD B66 @ 22.86 dBm	698.0	mA
	LTE-FDD B71 @ 22.73 dBm	628.0	mA
WCDMA voice	WCDMA B2 @ 22.63 dBm	578.0	mA

call	WCDMA B4 @ 22.74 dBm	581.0	mA
	WCDMA B5 @ 22.6 dBm	561.0	mA

Table 44: EC25-EU Current Consumption

Parameter	Description	Conditions	Typ.	Unit	
I_{VBAT}	OFF state	Power down	11	μ A	
		AT+CFUN=0 (USB disconnected)	1.82	mA	
		GSM DRX = 2 (USB disconnected)	2.74	mA	
		GSM DRX = 9 (USB disconnected)	2.0	mA	
		WCDMA PF = 64 (USB disconnected)	2.15	mA	
	Sleep state	WCDMA PF = 128 (USB disconnected)	1.67	mA	
		LTE-FDD PF = 64 (USB disconnected)	2.60	mA	
		LTE-FDD PF = 128 (USB disconnected)	1.90	mA	
		LTE-TDD PF = 64 (USB disconnected)	2.79	mA	
		LTE-TDD PF = 128 (USB disconnected)	2.00	mA	
		GSM DRX = 5 (USB disconnected)	19.5	mA	
		GSM DRX = 5 (USB connected)	29.5	mA	
		WCDMA PF = 64 (USB disconnected)	21.0	mA	
		WCDMA PF = 64 (USB connected)	31.0	mA	
	Idle state	LTE-FDD PF = 64 (USB disconnected)	20.7	mA	
		LTE-FDD PF = 64 (USB connected)	30.8	mA	
		LTE-TDD PF = 64 (USB disconnected)	20.8	mA	
		LTE-TDD PF = 64 (USB connected)	32.0	mA	
		GPRS data transfer (GNSS OFF)	EGSM900 4DL/1UL @ 33.23 dBm	243.0	mA
			EGSM900 3DL/2UL @ 31.96 dBm	388.0	mA

	EGSM900 2DL/3UL @ 29.73 dBm	453.0	mA
	EGSM900 1DL/4UL @ 28.5 dBm	522	mA
	DCS1800 4DL/1UL @ 30.49 dBm	172.0	mA
	DCS1800 3DL/2UL @ 29.24 dBm	274.0	mA
	DCS1800 2DL/3UL @ 27.15 dBm	337.0	mA
	DCS1800 1DL/4UL @ 25.88 dBm	406.0	mA
	EGSM900 4DL/1UL PCL = 8 @ 26.60 dBm	142.0	mA
	EGSM900 3DL/2UL PCL = 8 @ 25.43 dBm	229.0	mA
	EGSM900 2DL/3UL PCL = 8 @ 23.4 dBm	286.0	mA
EDGE data transfer (GNSS OFF)	EGSM900 1DL/4UL PCL = 8 @ 22.36 dBm	348.0	mA
	DCS1800 4DL/1UL PCL = 2 @ 25.59 dBm	136.0	mA
	DCS1800 3DL/2UL PCL = 2 @ 24.54 dBm	225.0	mA
	DCS1800 2DL/3UL PCL = 2 @ 22.38 dBm	300.0	mA
	DCS1800 1DL/4UL PCL = 2 @ 21.24 dBm	379.0	mA
WCDMA data transfer (GNSS OFF)	WCDMA B1 HSDPA @ 22.93 dBm	504.0	mA
	WCDMA B1 HSUPA @ 22.62 dBm	512.0	mA
	WCDMA B8 HSDPA @ 22.88 dBm	562.0	mA
	WCDMA B8 HSUPA @ 22.14 dBm	535.0	mA
LTE data transfer (GNSS OFF)	LTE-FDD B1 @ 23.6 dBm	664.0	mA
	LTE-FDD B3 @ 23.67 dBm	728.0	mA
	LTE-FDD B7 @ 23.83 dBm	821.0	mA
	LTE-FDD B8 @ 23.82 dBm	695.0	mA
	LTE-FDD B20 @ 23.88 dBm	649.0	mA
	LTE-FDD B28A @ 23.43 dBm	689.0	mA
	LTE-TDD B38 @ 22.82 dBm	438.0	mA

	LTE-TDD B40 @ 23.43 dBm	355.0	mA
	LTE-TDD B41 @ 23.46 dBm	451.0	mA
GSM voice call	EGSM900 PCL = 5 @ 33.25 dBm	258.0	mA
	DCS1800 PCL = 0 @ 30.23 dBm	178.0	mA
WCDMA voice call	WCDMA B1 @ 23.88 dBm	548.0	mA
	WCDMA B8 @ 23.8 dBm	615.0	mA

Table 45: EC25-EUX Current Consumption

Parameter	Description	Conditions	Typ.	Unit	
I _{VBAT}	OFF state	Power down	9	μA	
		AT+CFUN=0 (USB disconnected)	0.9	mA	
	Sleep state	GSM DRX = 2 (USB disconnected)	1.8	mA	
		GSM DRX = 9 (USB disconnected)	1.3	mA	
		WCDMA PF = 64 (USB disconnected)	1.6	mA	
		WCDMA PF = 128 (USB disconnected)	1.3	mA	
		LTE-FDD PF = 64 (USB disconnected)	2.2	mA	
		LTE-FDD PF = 128 (USB disconnected)	1.6	mA	
		LTE-TDD PF = 64 (USB disconnected)	2.2	mA	
		LTE-TDD PF = 128 (USB disconnected)	1.6	mA	
		Idle state	GSM DRX = 5 (USB disconnected)	14.5	mA
			GSM DRX = 5 (USB connected)	34.3	mA
	WCDMA PF = 64 (USB disconnected)		14.7	mA	
	WCDMA PF = 64 (USB connected)		35.3	mA	
	LTE-FDD PF = 64 (USB disconnected)		15.0	mA	
	LTE-FDD PF = 64 (USB connected)		36.5	mA	

	LTE-TDD PF = 64 (USB disconnected)	15.0	mA
	LTE-TDD PF = 64 (USB connected)	36.5	mA
	EGSM900 4DL/1UL @ 33.02 dBm	270.7	mA
	EGSM900 3DL/2UL @ 32.24 dBm	444.3	mA
	EGSM900 2DL/3UL @ 30.08 dBm	509.8	mA
GPRS data transfer (GNSS OFF)	EGSM900 1DL/4UL @ 29.50 dBm	629.3	mA
	DCS1800 4DL/1UL @ 29.63 dBm	157.4	mA
	DCS1800 3DL/2UL @ 28.96 dBm	246.3	mA
	DCS1800 2DL/3UL @ 27.49 dBm	310.6	mA
	DCS1800 1DL/4UL @ 26.44 dBm	377.7	mA
	EGSM900 4DL/1UL PCL = 8 @ 27.27 dBm	175.4	mA
	EGSM900 3DL/2UL PCL = 8 @ 26.13 dBm	292.1	mA
	EGSM900 2DL/3UL PCL = 8 @ 24.03 dBm	386.8	mA
EDGE data transfer (GNSS OFF)	EGSM900 1DL/4UL PCL = 8 @ 23.35 dBm	494.7	mA
	DCS1800 4DL/1UL PCL = 2 @ 25.92 dBm	134.5	mA
	DCS1800 3DL/2UL PCL = 2 @ 25.63 dBm	222.9	mA
	DCS1800 2DL/3UL PCL = 2 @ 23.14 dBm	301.2	mA
	DCS1800 1DL/4UL PCL = 2 @ 22.60 dBm	391.8	mA
WCDMA data transfer (GNSS OFF)	WCDMA B1 HSDPA @ 22.01 dBm	534.8	mA
	WCDMA B1 HSUPA @ 21.38 dBm	526.7	mA
	WCDMA B8 HSDPA @ 22.21 dBm	459.8	mA
	WCDMA B8 HSUPA @ 21.85 dBm	471.6	mA
LTE data transfer (GNSS OFF)	LTE-FDD B1 @ 23.38 dBm	743.4	mA
	LTE-FDD B3 @ 22.87 dBm	674.6	mA
	LTE-FDD B7 @ 22.08 dBm	658.8	mA

	LTE-FDD B8 @ 23.49 dBm	607.3	mA
	LTE-FDD B20 @ 23.01 dBm	711.0	mA
	LTE-FDD B28A @ 23.18 dBm	788.2	mA
	LTE-TDD B38 @ 23.38 dBm	446.6	mA
	LTE-TDD B40 @ 23.56 dBm	344.4	mA
	LTE-TDD B41 @ 23.17 dBm	483.2	mA
GSM voice call	EGSM900 PCL = 5 @ 32.81 dBm	262.2	mA
	DCS1800 PCL = 0 @ 29.62 dBm	151.2	mA
WCDMA voice call	WCDMA B1 @ 23.09 dBm	594.2	mA
	WCDMA B8 @ 23.18 dBm	504.3	mA

Table 46: EC25-MX Current Consumption

Parameter	Description	Conditions	Typ.	Unit
	OFF state	Power down	19	µA
		AT+CFUN=0 (USB disconnected)	1.0	mA
		WCDMA PF = 64 (USB disconnected)	2.3	mA
	Sleep state	WCDMA PF = 128 (USB disconnected)	1.7	mA
		LTE-FDD PF = 64 (USB disconnected)	2.5	mA
		LTE-FDD PF = 128 (USB disconnected)	2.2	mA
		WCDMA PF = 64 (USB disconnected)	12.9	mA
	Idle state	WCDMA PF = 64 (USB connected)	32.0	mA
		LTE-FDD PF = 64 (USB disconnected)	13.7	mA
		LTE-FDD PF = 64 (USB connected)	32.6	mA
	WCDMA data transfer (GNSS OFF)	WCDMA B2 HSDPA @ 22.27 dBm	581.9	mA
		WCDMA B2 HSUPA @ 22.15 dBm	603.0	mA

I _{BAT}		WCDMA B4 HSDPA @ 22.5 dBm	578.0	mA
		WCDMA B4 HSUPA @ 22.5 dBm	571.0	mA
		WCDMA B5 HSDPA @ 22.4 dBm	499.0	mA
		WCDMA B5 HSUPA @ 22.17 dBm	515.0	mA
LTE data transfer (GNSS OFF)		LTE-FDD B2 @ 23.2 dBm	685.0	mA
		LTE-FDD B4 @ 23.4 dBm	744.0	mA
		LTE-FDD B5 @ 23.2 dBm	578.0	mA
		LTE-FDD B7 @ 24.3 dBm	868.0	mA
		LTE-FDD B28 @ 23.45 dBm	631.0	mA
		LTE-FDD B66 @ 22.68 dBm	781.0	mA
	WCDMA voice call		WCDMA B2 @ 23.47 dBm	643.0
		WCDMA B4 @ 23.5 dBm	633.0	mA
		WCDMA B5 @ 23.5 dBm	551.0	mA

Table 47: EC25-AUX Current Consumption

Parameter	Description	Conditions	Typ.	Unit
I _{BAT}	OFF state	Power down	9	μA
	Sleep state		AT+CFUN=0 (USB disconnected)	0.9
		GSM DRX = 2 (USB disconnected)	2.4	mA
		LTE-FDD PF = 128 (USB disconnected)	2.5	mA
		LTE-TDD PF = 64 (USB disconnected)	3.4	mA
I _{BAT}	Idle state	GSM DRX = 5 (USB disconnected)	16.9	mA
		GSM DRX = 5 (USB connected)	34.5	mA
		WCDMA PF = 64 (USB disconnected)	17.9	mA
		WCDMA PF = 64 (USB connected)	35.2	mA

	LTE-FDD PF = 64 (USB disconnected)	18.3	mA
	LTE-FDD PF = 64 (USB connected)	35.1	mA
	LTE-TDD PF = 64 (USB disconnected)	18.4	mA
	LTE-TDD PF = 64 (USB connected)	35.1	mA
	GSM850 4DL/1UL @ 32.48 dBm	240.1	mA
	GSM850 3DL/2UL @ 31.59 dBm	384.8	mA
	GSM850 2DL/3UL @ 29.51 dBm	452.1	mA
	GSM850 1DL/4UL @ 28.41 dBm	542.1	mA
	EGSM900 4DL/1UL @ 33.27 dBm	272.7	mA
	EGSM900 3DL/2UL @ 31.99 dBm	406.9	mA
	EGSM900 2DL/3UL @ 29.67 dBm	470.2	mA
GPRS data transfer (GNSS OFF)	EGSM900 1DL/4UL @ 28.44 dBm	547.1	mA
	DCS1800 4DL/1UL @ 29.44 dBm	164.5	mA
	DCS1800 3DL/2UL @ 28.47 dBm	235.7	mA
	DCS1800 2DL/3UL @ 26.29 dBm	292.2	mA
	DCS1800 1DL/4UL @ 25.26 dBm	363.8	mA
	PCS1900 4DL/1UL @ 29.44 dBm	162.9	mA
	PCS1900 3DL/2UL @ 28.59 dBm	246.8	mA
	PCS1900 2DL/3UL @ 26.51 dBm	300.6	mA
	PCS1900 1DL/4UL @ 25.34 dBm	370.5	mA
EDGE data transfer (GNSS OFF)	GSM850 4DL/1UL @ 26.94 dBm	177.5	mA
	GSM850 3DL/2UL @ 25.90 dBm	290.8	mA
	GSM850 2DL/3UL @ 23.70 dBm	394.0	mA
	GSM850 1DL/4UL @ 22.47 dBm	504.5	mA
	EGSM900 4DL/1UL @ 27.18 dBm	176.6	mA

	EGSM900 3DL/2UL @ 26.03 dBm	289.6	mA
	EGSM900 2DL/3UL @ 23.97 dBm	390.7	mA
	EGSM900 1DL/4UL @ 22.68 dBm	502.1	mA
	DCS1800 4DL/1UL @ 26.01 dBm	141.0	mA
	DCS1800 3DL/2UL @ 25.02 dBm	227.5	mA
	DCS1800 2DL/3UL @ 23.04 dBm	316.3	mA
	DCS1800 1DL/4UL @ 22.11 dBm	411.0	mA
	PCS1900 4DL/1UL @ 26.24 dBm	143.3	mA
	PCS1900 3DL/2UL @ 25.46 dBm	231.4	mA
	PCS1900 2DL/3UL @ 23.45 dBm	316.1	mA
	PCS1900 1DL/4UL @ 22.38 dBm	411.0	mA
	WCDMA B1 HSDPA @ 22.60 dBm	534.6	mA
	WCDMA B1 HSUPA @ 22.48 dBm	541.3	mA
	WCDMA B2 HSDPA @ 21.60 dBm	572.9	mA
	WCDMA B2 HSUPA @ 22.06 dBm	560.0	mA
WCDMA data transfer (GNSS OFF)	WCDMA B4 HSDPA @ 22.97 dBm	495.8	mA
	WCDMA B4 HSUPA @ 23.20 dBm	512.4	mA
	WCDMA B5 HSDPA @ 22.63 dBm	493.1	mA
	WCDMA B5 HSUPA @ 22.98 dBm	504.7	mA
	WCDMA B8 HSDPA @ 22.46 dBm	545.5	mA
	WCDMA B8 HSUPA @ 21.89 dBm	541.1	mA
	LTE-FDD B1 @ 22.91 dBm	713.5	mA
LTE data transfer (GNSS OFF)	LTE-FDD B2 @ 22.85 dBm	713.4	mA
	LTE-FDD B3 @ 23.12 dBm	675.7	mA
	LTE-FDD B4 @ 22.52 dBm	607.8	mA

	LTE-FDD B5 @ 23.12 dBm	563.1	mA
	LTE-FDD B7 @ 22.95 dBm	702.9	mA
	LTE-FDD B8 @ 23.55 dBm	728.8	mA
	LTE-FDD B28 @ 23.23 dBm	769.3	mA
	LTE-TDD B40 @ 23.54 dBm	335.5	mA
GSM voice call	GSM850 PCL5 @ 32.36 dBm	240.3	mA
	EGSM900 PCL5 @ 33.15 dBm	260.9	mA
	DCS1800 PCL0 @ 29.38 dBm	153.0	mA
	PCS1900 PCL0 @ 29.47 dBm	160.3	mA
WCDMA voice call	WCDMA B1 @ 23.13 dBm	568.9	mA
	WCDMA B2 @ 22.99 dBm	628.4	mA
	WCDMA B4 @ 22.90 dBm	506.3	mA
	WCDMA B5 @ 23.10 dBm	507.5	mA
	WCDMA B8 @ 22.90 dBm	581.5	mA

Table 48: EC25-T Current Consumption

Parameter	Description	Conditions	Typ.	Unit
I _{BAT}	OFF state	Power down	7	µA
	Sleep state	AT+CFUN=0 (USB disconnected)	0.79	mA
		AT+CFUN=0 (USB Suspend)	1.01	mA
		AT+CFUN=4 (USB disconnected)	0.88	mA
		AT+CFUN=4 (USB Suspend)	1.09	mA
		LTE-FDD PF = 32 (USB disconnected)	3.05	mA
		LTE-FDD PF = 64 (USB disconnected)	2.11	mA
		LTE-FDD PF = 64 (USB Suspend)	2.17	mA

	LTE-FDD PF = 128 (USB disconnected)	1.68	mA
	LTE-FDD PF = 256 (USB disconnected)	1.13	mA
Idle state	LTE-FDD PF = 64 (USB disconnected)	18.71	mA
	LTE-FDD PF = 64 (USB active)	27.74	mA
LTE data transfer (GNSS OFF)	LTE-FDD B2 @ 23.23 dBm	683.1	mA
	LTE-FDD B4 @ 23.67 dBm	725.0	mA
	LTE-FDD B5 @ 23.39 dBm	582.8	mA
	LTE-FDD B12 @ 23.55 dBm	667.2	mA
	LTE-FDD B66 @ 22.94 dBm	729.6	mA
	LTE-FDD B71 @ 23.03 dBm	712.2	mA

Table 49: EC25-AFDL Current Consumption

Parameter	Description	Conditions	Typ.	Unit
I _{BAT}	OFF state	Power down	10	μA
		AT+CFUN=0 (USB disconnected)	1.0	mA
		LTE-FDD PF = 64 (USB disconnected)	2.2	mA
	Sleep state	LTE-FDD PF = 128 (USB disconnected)	1.8	mA
		LTE-FDD PF = 64 (USB disconnected)	17.6	mA
		LTE-FDD PF = 64 (USB connected)	29.4	mA
	Idle state	LTE-FDD PF = 64 (USB disconnected)	17.6	mA
		LTE-FDD PF = 64 (USB connected)	29.4	mA
	LTE data transfer (GNSS OFF)	LTE-FDD B2 @ 22.92 dBm	698.0	mA
		LTE-FDD B4 @ 23.12 dBm	710.0	mA
		LTE-FDD B5 @ 22.98 dBm	650.0	mA
		LTE-FDD B12 @ 23.42 dBm	648.0	mA

LTE-FDD B13 @ 22.92 dBm	690.0	mA
LTE-FDD B14 @ 23.42 dBm	685.0	mA
LTE-FDD B66 @ 23.35 dBm	715.0	mA
LTE-FDD B71 @ 23.39 dBm	689.0	mA

Table 50: GNSS Current Consumption of EC25 Series Module

Parameter	Description	Conditions	Typ.	Unit
I _{BAT} (GNSS)	Searching (AT+CFUN=0)	Cold start @ Passive Antenna	54.0	mA
		Lost state @ Passive Antenna	53.9	mA
	Tracking (AT+CFUN=0)	Instrument Environment	30.5	mA
		Open Sky @ Passive Antenna	33.2	mA
		Open Sky @ Active Antenna	40.8	mA

6.5. RF Output Power

The following table shows the RF output power of EC25 series module.

Table 51: RF Output Power

Frequency	Max. Output Power	Min. Output Power
GSM850/EGSM900	33 dBm ±2 dB	5 dBm ±5 dB
DCS1800/PCS1900	30 dBm ±2 dB	0 dBm ±5 dB
GSM850/EGSM900 (8-PSK)	27 dBm ±3 dB	5 dBm ±5 dB
DCS1800/PCS1900 (8-PSK)	26 dBm ±3 dB	0 dBm ±5 dB
WCDMA bands	24 dBm + 1/-3 dB	< -49 dBm
LTE-FDD bands	23 dBm ±2 dB	< -39 dBm

LTE-TDD bands

23 dBm ±2 dB

< -39 dBm

NOTE

In GPRS 4 slots TX mode, the maximum output power is reduced by 3.0 dB. The design conforms to the GSM specification as described in **Chapter 13.16** of *3GPP TS 51.010-1*.

6.6. RF Receiving Sensitivity

The following tables show the conducted RF receiving sensitivity of EC25 series module.

Table 52: EC25-E Conducted RF Receiving Sensitivity

Frequency Bands	Primary	Diversity	SIMO ¹⁾	3GPP (SIMO)
EGSM900	-109.0 dBm	/	/	-102.0 dBm
DCS1800	-109.0 dBm	/	/	-102.0dbm
WCDMA B1	-110.5 dBm	/	/	-106.7 dBm
WCDMA B5	-110.5 dBm	/	/	-104.7 dBm
WCDMA B8	-110.5 dBm	/	/	-103.7 dBm
LTE-FDD B1 (10 MHz)	-98.0 dBm	-98.0 dBm	-101.5 dBm	-96.3 dBm
LTE-FDD B3 (10 MHz)	-96.5 dBm	-98.5 dBm	-101.5 dBm	-93.3 dBm
LTE-FDD B5 (10 MHz)	-98.0 dBm	-98.5 dBm	-101.0 dBm	-94.3 dBm
LTE-FDD B7 (10 MHz)	-97.0 dBm	-97.0 dBm	-99.5 dBm	-94.3 dBm
LTE-FDD B8 (10 MHz)	-97.0 dBm	-97.0 dBm	-101.0 dBm	-93.3 dBm
LTE-FDD B20 (10 MHz)	-97.5 dBm	-99.0 dBm	-102.5 dBm	-93.3 dBm
LTE-TDD B38 (10 MHz)	-95 dBm	-97.0 dBm	-98.9 dBm	-96.3 dBm
LTE-TDD B40 (10 MHz)	-96.3 dBm	-98.0 dBm	-101.0 dBm	-96.3 dBm
LTE-TDD B41 (10 MHz)	-94.5 dBm	-97.0 dBm	-98.5 dBm	-94.3 dBm

Table 53: EC25-A Conducted RF Receiving Sensitivity

Frequency Bands	Primary	Diversity	SIMO ¹⁾	3GPP (SIMO)
WCDMA B2	-110.0 dBm	/	/	-104.7 dBm
WCDMA B4	-110.0 dBm	/	/	-106.7 dBm
WCDMA B5	-110.5 dBm	/	/	-104.7 dBm
LTE-FDD B2 (10 MHz)	-98.0 dBm	-98.0 dBm	-101.0 dBm	-94.3 dBm
LTE-FDD B4 (10 MHz)	-97.5 dBm	-99.0 dBm	-101.0 dBm	-96.3 dBm
LTE-FDD B12 (10 MHz)	-97.2 dBm	-98.0 dBm	-101.0 dBm	-93.3 dBm

Table 54: EC25-V Conducted RF Receiving Sensitivity

Frequency Bands	Primary	Diversity	SIMO ¹⁾	3GPP (SIMO)
LTE-FDD B4 (10 MHz)	-97.5 dBm	-99.0 dBm	-101.0 dBm	-96.3 dBm
LTE-FDD B13 (10 MHz)	-97.7 dBm	-97.0 dBm	-100.0 dBm	-93.3 dBm

Table 55: EC25-J Conducted RF Receiving Sensitivity

Frequency Bands	Primary	Diversity	SIMO ¹⁾	3GPP (SIMO)
WCDMA B1	-110.0 dBm	-110.5 dBm	-111.0 dBm	-106.7 dBm
WCDMA B6	-110.5 dBm	-110.5 dBm	-111.0 dBm	-106.7 dBm
WCDMA B8	-110.5 dBm	-111.0 dBm	-111.0 dBm	-103.7 dBm
WCDMA B19	-110.5 dBm	-110.5 dBm	-111.0 dBm	-106.7 dBm
LTE-FDD B1 (10 MHz)	-97.5 dBm	-98.7 dBm	-100.2 dBm	-96.3 dBm
LTE-FDD B3 (10 MHz)	-96.5 dBm	-97.1 dBm	-100.5 dBm	-93.3 dBm
LTE-FDD B8 (10 MHz)	-98.4 dBm	-99.0 dBm	-101.2 dBm	-93.3 dBm
LTE-FDD B18 (10 MHz)	-99.5 dBm	-99.0 dBm	-101.7 dBm	-96.3 dBm
LTE-FDD B19 (10 MHz)	-99.2 dBm	-99.0 dBm	-101.4 dBm	-96.3 dBm

LTE-FDD B26 (10 MHz)	-99.5 dBm	-99.0 dBm	-101.5 dBm	-93.8 dBm
LTE-TDD B41 (10 MHz)	-95.0 dBm	-95.7 dBm	-99.0 dBm	-94.3 dBm

Table 56: EC25-JL Conducted RF Receiving Sensitivity

Frequency Bands	Primary	Diversity	SIMO ¹⁾	3GPP (SIMO)
LTE-FDD B1 (10 MHz)	-97.5 dBm	-98.7 dBm	-100.2 dBm	-96.3 dBm
LTE-FDD B3 (10 MHz)	-96.5 dBm	-97.1 dBm	-100.5 dBm	-93.3 dBm
LTE-FDD B8 (10 MHz)	-98.4 dBm	-99.0 dBm	-101.2 dBm	-93.3 dBm
LTE-FDD B18 (10 MHz)	-99.5 dBm	-99.0 dBm	-101.7 dBm	-96.3 dBm
LTE-FDD B19 (10 MHz)	-99.2 dBm	-99.0 dBm	-101.4 dBm	-96.3 dBm
LTE-FDD B26 (10 MHz)	-99.5 dBm	-99.0 dBm	-101.5 dBm	-93.8 dBm
LTE-TDD B41 (10 MHz)	-95.0 dBm	-95.7 dBm	-99.0 dBm	-94.3 dBm

Table 57: EC25-AU Conducted RF Receiving Sensitivity

Frequency Bands	Primary	Diversity	SIMO ¹⁾	3GPP (SIMO)
GSM850	-109.0 dBm	/	/	-102.0 dBm
EGSM900	-109.0 dBm	/	/	-102.0 dBm
DCS1800	-109.0 dBm	/	/	-102.0 dBm
PCS1900	-109.0 dBm	/	/	-102.0 dBm
WCDMA B1	-110.0 dBm	-109 dBm	-112 dBm	-106.7 dBm
WCDMA B2	-110.0 dBm	/	/	-104.7 dBm
WCDMA B5	-111.0 dBm	-112 dBm	-113 dBm	-104.7 dBm
WCDMA B8	-111.0 dBm	-111 dBm	-113 dBm	-103.7 dBm
LTE-FDD B1 (10 MHz)	-97.2 dBm	-97.5 dBm	-100.2 dBm	-96.3 dBm
LTE-FDD B2 (10 MHz)	-98.2 dBm	/	/	-94.3 dBm

LTE-FDD B3 (10 MHz)	-98.7 dBm	-98.6 dBm	-102.2 dBm	-93.3 dBm
LTE-FDD B4 (10 MHz)	-97.7 dBm	-97.4 dBm	-100.2 dBm	-96.3 dBm
LTE-FDD B5 (10 MHz)	-98.0 dBm	-98.2 dBm	-101.0 dBm	-94.3 dBm
LTE-FDD B7 (10 MHz)	-97.7 dBm	-97.7 dBm	-101.2 dBm	-94.3 dBm
LTE-FDD B8 (10 MHz)	-99.2 dBm	-98.2 dBm	-102.2 dBm	-93.3 dBm
LTE-FDD B28 (10 MHz)	-98.6 dBm	-98.7 dBm	-102.0 dBm	-94.8 dBm
LTE-TDD B40 (10 MHz)	-97.2 dBm	-98.4 dBm	-101.2 dBm	-96.3 dBm

Table 58: EC25-AUT Conducted RF Receiving Sensitivity

Frequency Bands	Primary	Diversity	SIMO ⁽¹⁾	3GPP (SIMO)
WCDMA B1	-110.0 dBm	/	/	-106.7 dBm
WCDMA B5	-110.5 dBm	/	/	-104.7 dBm
LTE-FDD B1 (10 MHz)	-98.5 dBm	-98.0 dBm	-101.0 dBm	-96.3 dBm
LTE-FDD B3 (10 MHz)	-98.0 dBm	-97.0 dBm	-100.0 dBm	-93.3 dBm
LTE-FDD B5 (10 MHz)	-98.0 dBm	-99.0 dBm	-102.5 dBm	-94.3 dBm
LTE-FDD B7 (10 MHz)	-97.0 dBm	-97.0 dBm	-98.5 dBm	-94.3 dBm
LTE-FDD B28 (10 MHz)	-97.0 dBm	-99.0 dBm	-102.0 dBm	-94.8 dBm

Table 59: EC25-AUTL Conducted RF Receiving Sensitivity

Frequency Bands	Primary	Diversity	SIMO ⁽¹⁾	3GPP (SIMO)
LTE-FDD B3 (10 MHz)	-98.0 dBm	-97.0 dBm	-100.0 dBm	-93.3 dBm
LTE-FDD B7 (10 MHz)	-97.0 dBm	-97.0 dBm	-98.5 dBm	-94.3 dBm
LTE-FDD B28 (10 MHz)	-97.0 dBm	-99.0 dBm	-102.0 dBm	-94.8 dBm

Table 60: EC25-AF Conducted RF Receiving Sensitivity

Frequency Bands	Primary	Diversity	SIMO ¹⁾	3GPP (SIMO)
WCDMA B2	-109.5 dBm	-110 dBm	-110.4 dBm	-104.7 dBm
WCDMA B4	-109.6 dBm	-110 dBm	-110.6 dBm	-106.7 dBm
WCDMA B5	-110 dBm	-110 dBm	-110.7 dBm	-104.7 dBm
LTE-FDD B2 (10 MHz)	-98.0 dBm	-98.5 dBm	-100.5 dBm	-94.3 dBm
LTE-FDD B4 (10 MHz)	-97.5 dBm	-98.2 dBm	-99.5 dBm	-96.3 dBm
LTE-FDD B5 (10 MHz)	-98.0 dBm	-98.5 dBm	-100.5 dBm	-94.3 dBm
LTE-FDD B12 (10 MHz)	-99.0 dBm	-99.5 dBm	-100.5 dBm	-93.3 dBm
LTE-FDD B13 (10 MHz)	-98.5 dBm	-99.5 dBm	-100.7 dBm	-93.3 dBm
LTE-FDD B14 (10 MHz)	-99.4 dBm	-99.5 dBm	-100.9 dBm	-93.3 dBm
LTE-FDD B66 (10 MHz)	-97.5 dBm	-98.5 dBm	-99.6 dBm	-95.8 dBm
LTE-FDD B71 (10 MHz)	-98.6 dBm	-99.5 dBm	-100 dBm	-93.5 dBm

Table 61: EC25-AFX Conducted RF Receiving Sensitivity

Frequency Bands	Primary	Diversity	SIMO ¹⁾	3GPP (SIMO)
WCDMA B2	-109.5 dBm	-110 dBm	-110.4 dBm	-104.7 dBm
WCDMA B4	-109.6 dBm	-110 dBm	-110.6 dBm	-106.7 dBm
WCDMA B5	-110 dBm	-110 dBm	-110.7 dBm	-104.7 dBm
LTE-FDD B2 (10 MHz)	-98.0 dBm	-98.5 dBm	-100.5 dBm	-94.3 dBm
LTE-FDD B4 (10 MHz)	-97.5 dBm	-98.2 dBm	-99.5 dBm	-96.3 dBm
LTE-FDD B5 (10 MHz)	-98.0 dBm	-98.5 dBm	-100.5 dBm	-94.3 dBm
LTE-FDD B12 (10 MHz)	-99.0 dBm	-99.5 dBm	-100.5 dBm	-93.3 dBm
LTE-FDD B13 (10 MHz)	-98.5 dBm	-99.5 dBm	-100.7 dBm	-93.3 dBm
LTE-FDD B14 (10 MHz)	-99.4 dBm	-99.5 dBm	-100.9 dBm	-93.3 dBm

LTE-FDD B66 (10 MHz)	-97.5 dBm	-98.5 dBm	-99.6 dBm	-95.8 dBm
LTE-FDD B71 (10 MHz)	-98.6 dBm	-99.5 dBm	-100 dBm	-93.5 dBm

Table 62: EC25-EU Conducted RF Receiving Sensitivity

Frequency Bands	Primary	Diversity	SIMO ¹⁾	3GPP (SIMO)
EGSM900	-108.5 dBm	/	/	-102.0 dBm
DCS1800	-108.5 dBm	/	/	-102.0dbm
WCDMA B1	-109.5 dBm	-109.5 dBm	/	-106.7 dBm
WCDMA B8	-110.0 dBm	-111.5 dBm	/	-103.7 dBm
LTE-FDD B1 (10 MHz)	-98.5 dBm	-99.0 dBm	-101.7 dBm	-96.3 dBm
LTE-FDD B3 (10 MHz)	-98.2 dBm	-99.8 dBm	-102 dBm	-93.3 dBm
LTE-FDD B7 (10 MHz)	-96.7 dBm	-98.5 dBm	-100.7 dBm	-94.3 dBm
LTE-FDD B8 (10 MHz)	-98.5 dBm	-100.4 dBm	-102.4 dBm	-93.3 dBm
LTE-FDD B20 (10 MHz)	-98.7 dBm	-100.2 dBm	-102.7 dBm	-93.3 dBm
LTE-FDD B28 (10 MHz)	-98.7 dBm	-100.5 dBm	-102.5 dBm	-94.8 dBm
LTE-TDD B38 (10 MHz)	-95.2 dBm	-97.0 dBm	-100.2 dBm	-96.3 dBm
LTE-TDD B40 (10 MHz)	-95.7 dBm	-98.2 dBm	-101.2 dBm	-96.3 dBm
LTE-TDD B41 (10 MHz)	-95.0 dBm	-97.1 dBm	-100.2 dBm	-94.3 dBm

Table 63: EC25-EUX Conducted RF Receiving Sensitivity

Frequency Bands	Primary	Diversity	SIMO ¹⁾	3GPP (SIMO)
EGSM900	-109.0 dBm	/	/	-102.0 dBm
DCS1800	-109.0 dBm	/	/	-102.0 dbm
WCDMA B1	-110.5 dBm	-110.5 m	-111.0 dBm	-106.7 dBm
WCDMA B8	-110.5 dBm	-110.5 dBm	-111.0 dBm	-103.7 dBm
LTE-FDD B1 (10 MHz)	-98.0 dBm	-98.0 dBm	-101 dBm	-96.3 dBm

LTE-FDD B3 (10 MHz)	-96.5 dBm	-98.5 dBm	-99.5 dBm	-93.3 dBm
LTE-FDD B7 (10 MHz)	-97.0 dBm	-94.5 dBm	-99.5 dBm	-94.3 dBm
LTE-FDD B8 (10 MHz)	-97.0 dBm	-97.0 dBm	-100.0 dBm	-93.3 dBm
LTE-FDD B20 (10 MHz)	-97.5 dBm	-99.0 dBm	-101.5 dBm	-93.3 dBm
LTE-FDD B28 (10 MHz)	-98.6 dBm	-98.7 dBm	-101.0 dBm	-94.8 dBm
LTE-TDD B38 (10 MHz)	-96.3 dBm	-97 dBm	-98.5 dBm	-96.3 dBm
LTE-TDD B40 (10 MHz)	-96.9 dBm	-98.0 dBm	-99.1 dBm	-96.3 dBm
LTE-TDD B41 (10 MHz)	-95.3 dBm	-97.5 dBm	-98.0 dBm	-94.3 dBm

Table 64: EC25-MX Conducted RF Receiving Sensitivity

Frequency Bands	Primary	Diversity	SIMO ⁽¹⁾	3GPP (SIMO)
WCDMA B2	-109 dBm	-110.5 dBm	/	-104.7 dBm
WCDMA B4	-109.5 dBm	-110 dBm	/	-106.7 dBm
WCDMA B5	-110 dBm	-111 dBm	/	-104.7 dBm
LTE-FDD B2 (10 MHz)	-98 dBm	-99.1 dBm	-101.5 dBm	-94.3 dBm
LTE-FDD B4 (10 MHz)	-98.5 dBm	-98.2 dBm	-101.5 dBm	-96.3 dBm
LTE-FDD B5 (10 MHz)	-99 dBm	-99.2 dBm	-102.5 dBm	-94.3 dBm
LTE-FDD B7 (10 MHz)	-97 dBm	-98.5 dBm	-101.5 dBm	-94.3 dBm
LTE-FDD B28 (10 MHz)	-98 dBm	-99.3 dBm	-102 dBm	-94.8 dBm
LTE-FDD B66 (10 MHz)	-98 dBm	-98.4 dBm	-101.5 dBm	-95.8 dBm

Table 65: EC25-AUX Conducted RF Receiving Sensitivity

Frequency Bands	Primary	Diversity	SIMO ⁽¹⁾	3GPP (SIMO)
GSM850	-109.0 dBm	/	/	-102.0 dBm
EGSM900	-109.0 dBm	/	/	-102.0 dBm

DCS1800	-109.0 dBm	/	/	-102.0 dBm
PCS1900	-109.0 dBm	/	/	-102.0 dBm
WCDMA B1	-110.0 dBm	-109.5 dBm	-112 dBm	-106.7 dBm
WCDMA B2	-110.5 dBm	/	/	-104.7 dBm
WCDMA B4	-110.0 dBm	-110 dBm	-112 dBm	-104.7 dBm
WCDMA B5	-111.0 dBm	-112 dBm	-113 dBm	-104.7 dBm
WCDMA B8	-111.0 dBm	-112 dBm	-113 dBm	-103.7 dBm
LTE-FDD B1 (10 MHz)	-98.0 dBm	-97.7 dBm	-101.2 dBm	-96.3 dBm
LTE-FDD B2 (10 MHz)	-98.5 dBm	/	/	-94.3 dBm
LTE-FDD B3 (10 MHz)	-99.0 dBm	-98.8 dBm	-102.2 dBm	-93.3 dBm
LTE-FDD B4 (10 MHz)	-97.7 dBm	-97.6 dBm	-100.2 dBm	-96.3 dBm
LTE-FDD B5 (10 MHz)	-98.5 dBm	-98.2 dBm	-101.0 dBm	-94.3 dBm
LTE-FDD B7 (10 MHz)	-97.7 dBm	-97.7 dBm	-101.2 dBm	-94.3 dBm
LTE-FDD B8 (10 MHz)	-99.0 dBm	-98.5 dBm	-102.2 dBm	-93.3 dBm
LTE-FDD B28 (10 MHz)	-98.0 dBm	-98.7 dBm	-101.5 dBm	-94.8 dBm
LTE-TDD B40 (10 MHz)	-97.5 dBm	-98.2 dBm	-101.2 dBm	-96.3 dBm

Table 66: EC25-EX Conducted RF Receiving Sensitivity

Frequency Bands	Primary	Diversity	SIMO ¹⁾	3GPP (SIMO)
EGSM900	-108.8 dBm	/	/	-102.0 dBm
DCS1800	-108.8 dBm	/	/	-102.0dbm
WCDMA B1	-110.0 dBm	/	/	-106.7 dBm
WCDMA B5	-110.0 dBm	/	/	-104.7 dBm
WCDMA B8	-110.0 dBm	/	/	-103.7 dBm
LTE-FDD B1 (10 MHz)	-98.0 dBm	/	/	-96.3 dBm

LTE-FDD B3 (10 MHz)	-98.4 dBm	/	/	-93.3 dBm
LTE-FDD B5 (10 MHz)	-99.0dBm	/	/	-94.3 dBm
LTE-FDD B7 (10 MHz)	-96.5 dBm	/	/	-94.3 dBm
LTE-FDD B8 (10 MHz)	-98.8 dBm	/	/	-93.3 dBm
LTE-FDD B20 (10 MHz)	-98.0 dBm	/	/	-93.3 dBm
LTE-TDD B38 (10 MHz)	-97.3 dBm	/	/	-96.3 dBm
LTE-TDD B40 (10 MHz)	-97.3 dBm	/	/	-96.3 dBm
LTE-TDD B41 (10 MHz)	-97.3 dBm	/	/	-94.3 dBm

Table 67: EC25-T Conducted RF Receiving Sensitivity

Frequency Bands	Primary	Diversity	SIMO ⁽¹⁾	3GPP (SIMO)
LTE-FDD B2 (10 MHz)	-98.0 dBm	-98.5 dBm	-99.5 dBm	-94.3 dBm
LTE-FDD B4 (10 MHz)	-97.5 dBm	-98.2 dBm	-99.3 dBm	-96.3 dBm
LTE-FDD B5 (10 MHz)	-98.0 dBm	-98.5 dBm	-99.8 dBm	-94.3 dBm
LTE-FDD B12 (10 MHz)	-98.6 dBm	-98.5 dBm	-99.6 dBm	-93.3 dBm
LTE-FDD B66 (10 MHz)	-97.5 dBm	-98.2 dBm	-99.3 dBm	-95.8 dBm
LTE-FDD B71 (10 MHz)	-98.6 dBm	-99.5 dBm	-99.9 dBm	-93.5 dBm

Table 68: EC25-AFDL Conducted RF Receiving Sensitivity

Frequency Bands	Primary	Diversity	SIMO ⁽¹⁾	3GPP (SIMO)
LTE-FDD B2 (10 MHz)	-98.0 dBm	-98.5 dBm	-100.5 dBm	-94.3 dBm
LTE-FDD B4 (10 MHz)	-97.5 dBm	-98.2 dBm	-99.5 dBm	-96.3 dBm
LTE-FDD B5 (10 MHz)	-98.0 dBm	-98.5 dBm	-100.5 dBm	-94.3 dBm
LTE-FDD B12 (10 MHz)	-99.0 dBm	-99.5 dBm	-100.5 dBm	-93.3 dBm
LTE-FDD B13 (10 MHz)	-98.5 dBm	-99.5 dBm	-100.7 dBm	-93.3 dBm
LTE-FDD B14 (10 MHz)	-99.4 dBm	-99.5 dBm	-100.9 dBm	-93.3 dBm

LTE-FDD B66 (10 MHz)	-97.5 dBm	-98.5 dBm	-99.6 dBm	-95.8 dBm
LTE-FDD B71 (10 MHz)	-98.6 dBm	-99.5 dBm	-100 dBm	-93.5 dBm

NOTE

¹⁾ SIMO is a smart antenna technology that uses a single antenna at the transmitter side and two antennas at the receiver side, which can improve RX performance.

6.7. Electrostatic Discharge

The module is not protected against electrostatics discharge (ESD) in general. Consequently, it is subject to ESD handling precautions that typically apply to ESD sensitive components. Proper ESD handling and packaging procedures must be applied throughout the processing, handling and operation of any application that incorporates the module.

The following table shows the module’s electrostatics discharge characteristics.

Table 68: Electrostatics Discharge Characteristics (25 °C, 45% Relative Humidity)

Tested Interfaces	Contact Discharge	Air Discharge	Unit
VBAT, GND	±5	±10	kV
All Antenna Interfaces	±4	±8	kV
Other Interfaces	±0.5	±1	kV

6.8. Thermal Consideration

In order to achieve better performance of the module, it is recommended to comply with the following principles for thermal consideration:

- On customers’ PCB design, please keep placement of the module away from heating sources, especially high power components such as ARM processor, audio power amplifier, power supply, etc.
- Do not place components on the opposite side of the PCB area where the module is mounted, in

order to facilitate adding of heatsink when necessary.

- Do not apply solder mask on the opposite side of the PCB area where the module is mounted, so as to ensure better heat dissipation performance.
- The reference ground of the area where the module is mounted should be complete, and add ground vias as many as possible for better heat dissipation.
- Make sure the ground pads of the module and PCB are fully connected.
- According to customers' application demands, the heatsink can be mounted on the top of the module, or the opposite side of the PCB area where the module is mounted, or both of them.
- The heatsink should be designed with as many fins as possible to increase heat dissipation area. Meanwhile, a thermal pad with high thermal conductivity should be used between the heatsink and module/PCB.

The following shows two kinds of heatsink designs for reference and customers can choose one or both of them according to their application structure.

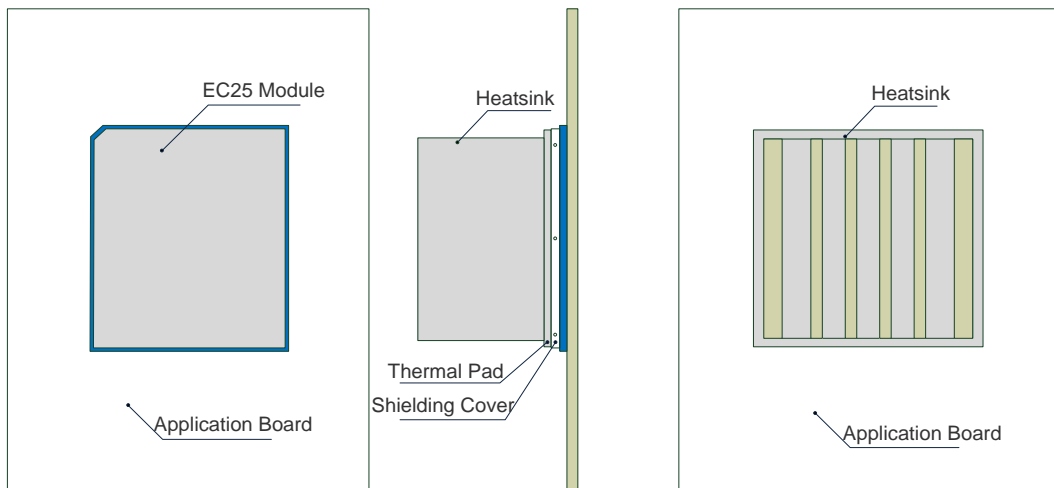

Figure 42: Referenced Heatsink Design (Heatsink at the Top of the Module)

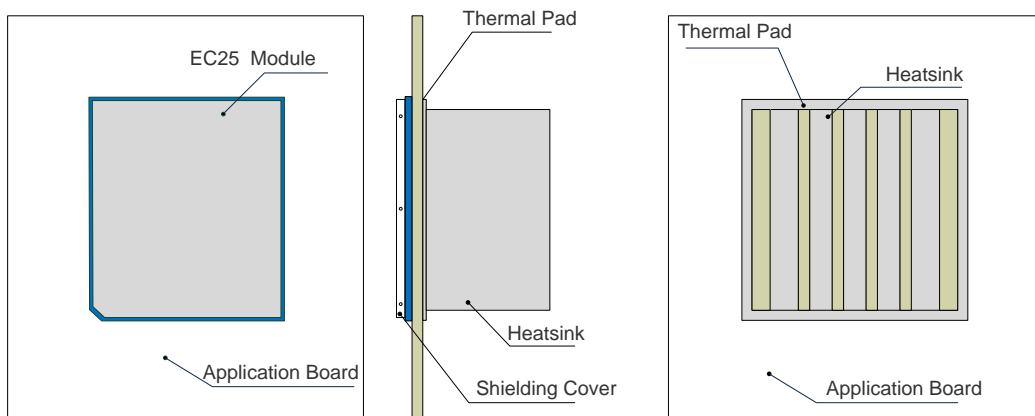

Figure 43: Referenced Heatsink Design (Heatsink at the Backside of Customers' PCB)

NOTES

1. The module offers the best performance when the internal BB chip stays below 105 °C. When the maximum temperature of the BB chip reaches or exceeds 105 °C, the module works normal but provides reduced performance (such as RF output power, data rate, etc.). When the maximum BB chip temperature reaches or exceeds 115 °C, the module will disconnect from the network, and it will recover to network connected state after the maximum temperature falls below 115 °C. Therefore, the thermal design should be maximally optimized to make sure the maximum BB chip temperature always maintains below 105 °C. Customers can execute **AT+QTEMP** command and get the maximum BB chip temperature from the first returned value.
 2. For more detailed guidelines on thermal design, please refer to **document [7]**.
-

7 Mechanical Dimensions

This chapter describes the mechanical dimensions of the module. All dimensions are measured in millimeter (mm), and the dimensional tolerances are ± 0.05 mm unless otherwise specified.

7.1. Mechanical Dimensions of the Module

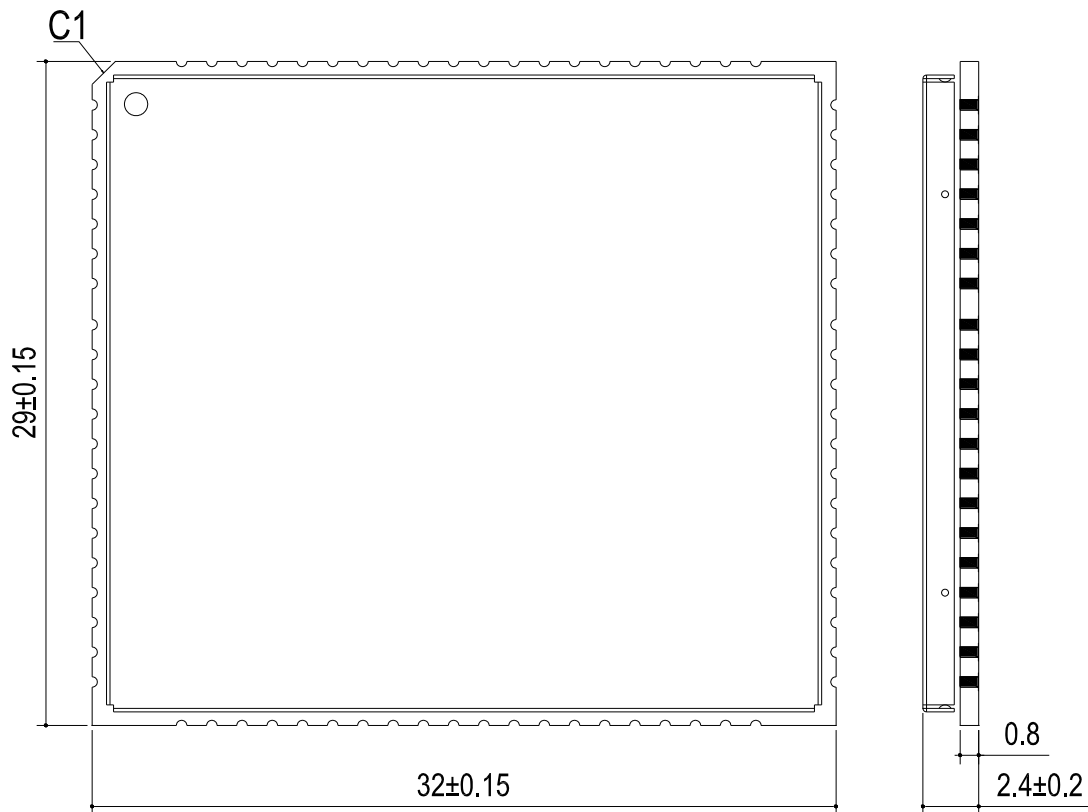

Figure 44: Module Top and Side Dimensions

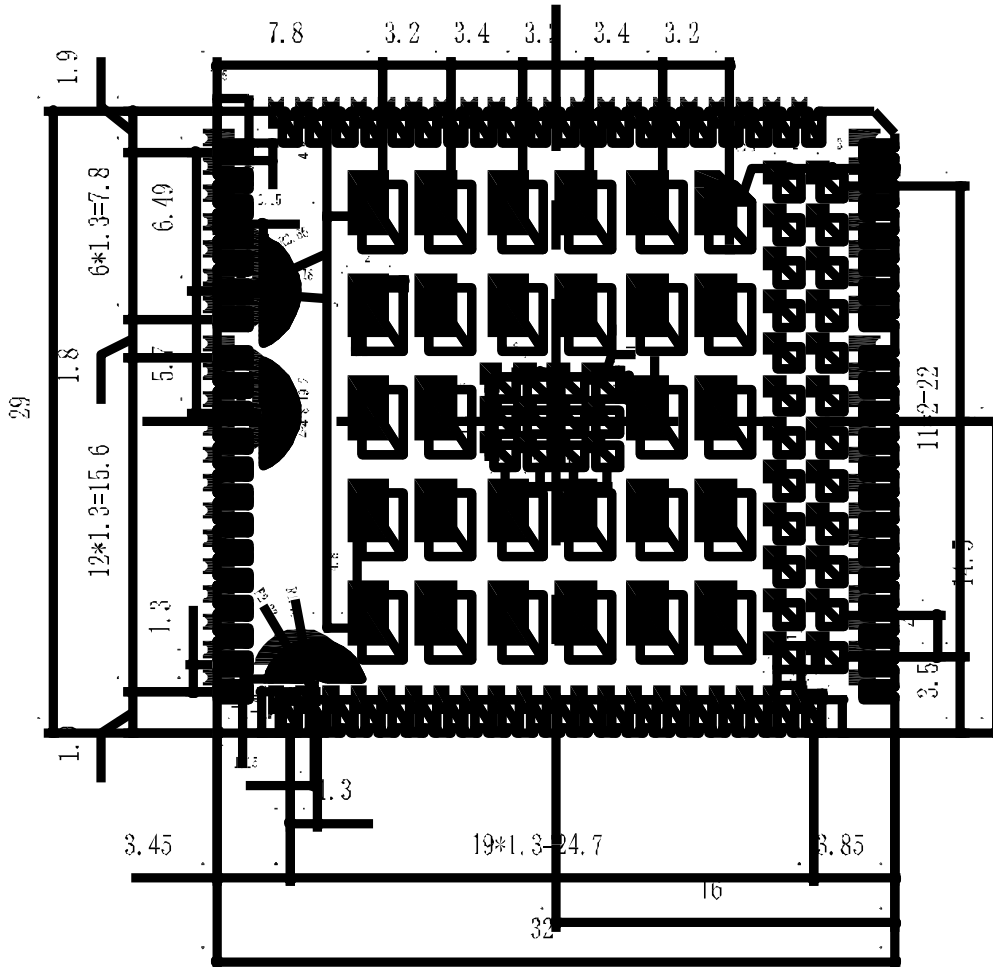

Figure 45: Module Bottom Dimensions (Bottom View)

NOTE

The package warpage level of the module conforms to JEITA ED-7306 standard.

7.2. Recommended Footprint

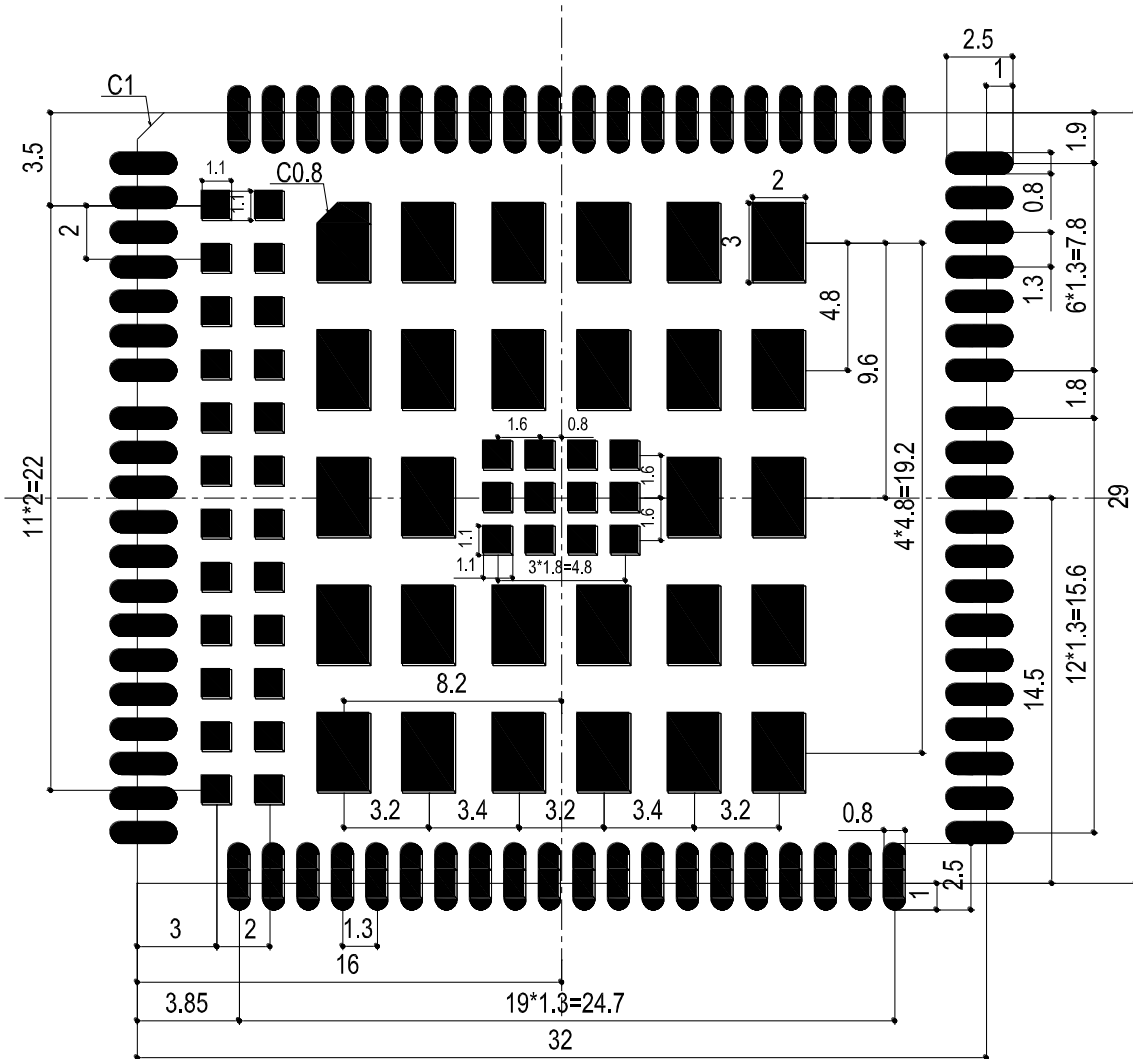

Figure 46: Recommended Footprint (Top View)

NOTES

1. The keepout area should not be designed.
2. For easy maintenance of this module, please keep about 3 mm between the module and other components on the motherboard.

7.3. Design Effect Drawings of the Module



Figure 47: Top View of the Module

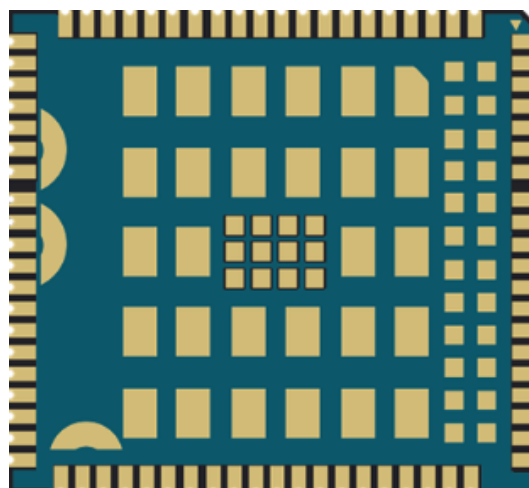

Figure 48: Bottom View of the Module

NOTE

These are renderings of EC25 series module. For authentic appearance, please refer to the module received from Quectel.

8 Storage, Manufacturing and Packaging

8.1. Storage

EC25 is provided with vacuum-sealed packaging. MSL of the module is rated as 3. The storage requirements are shown below.

1. Recommended Storage Condition: The temperature should be 23 ± 5 °C and the relative humidity should be 35–60 %.
2. The storage life (in vacuum-sealed packaging) is 12 months in Recommended Storage Condition.
3. The floor life of the module is 24 hours in a plant where the temperature is 23 ± 5 °C and relative humidity is below 60 %. After the vacuum-sealed packaging is removed, the module must be processed in reflow soldering or other high-temperature operations within 24 hours. Otherwise, the module should be stored in an environment where the relative humidity is less than 10 % (e.g. a drying cabinet).
4. The module should be pre-baked to avoid blistering, cracks and inner-layer separation in PCB under the following circumstances:
 - The module is not stored in Recommended Storage Condition;
 - Violation of the third requirement above occurs;
 - Vacuum-sealed packaging is broken, or the packaging has been removed for over 24 hours;
 - Before module repairing.
5. If needed, the pre-baking should follow the requirements below:
 - The module should be baked for 8 hours at 120 ± 5 °C;

All modules must be soldered to PCB within 24 hours after the baking, otherwise they should be put in a dry environment such as in a drying oven.

NOTE

As the plastic package cannot be subjected to high temperature, it should be removed from devices before high temperature (120 °C) baking. If shorter baking time is desired, please refer to *IPC/JEDECJ-STD-033* for baking procedure.

8.2. Manufacturing and Soldering

Push the squeegee to apply the solder paste on the surface of stencil, thus making the paste fill the stencil openings and then penetrate to the PCB. The force on the squeegee should be adjusted properly so as to produce a clean stencil surface on a single pass. To ensure the module soldering quality, the thickness of stencil for the module is recommended to be 0.18–0.20 mm. For more details, please refer to *document [4]*.

It is suggested that the peak reflow temperature is 238–245 °C, and the absolute maximum reflow temperature is 245 °C. To avoid damage to the module caused by repeated heating, it is strongly recommended that the module should be mounted after reflow soldering for the other side of PCB has been completed. The recommended reflow soldering thermal profile (lead-free reflow soldering) and related parameters are shown below.

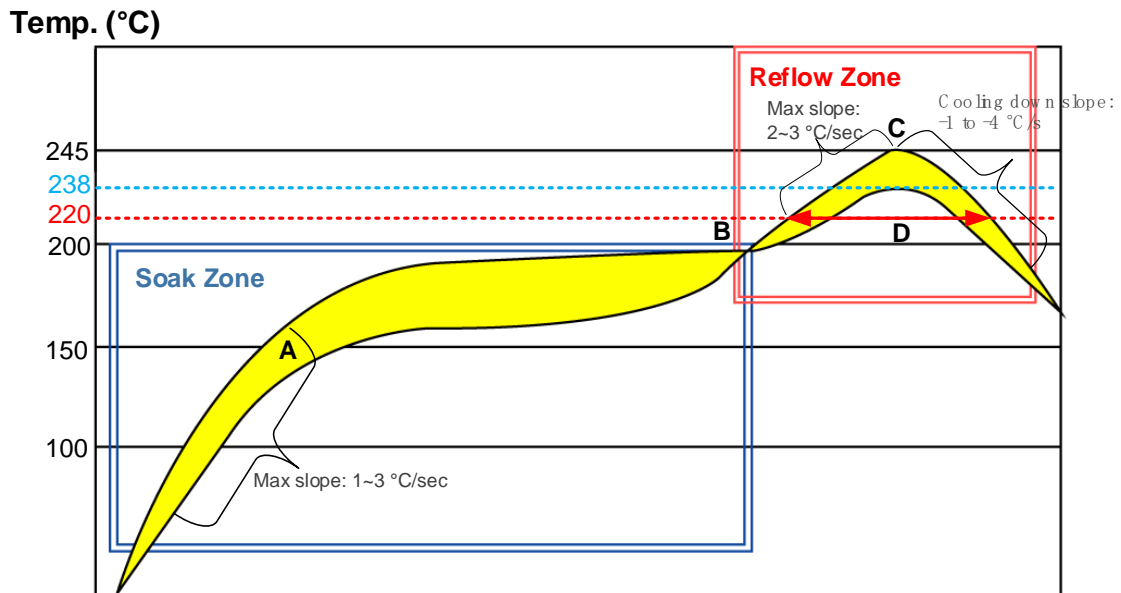

Figure 49: Reflow Soldering Thermal Profile

Table 69: Recommended Thermal Profile Parameters

Factor	Recommendation
Soak Zone	
Max slope	1–3 °C/s
Soak time (between A and B: 150 °C and 200 °C)	70–120 s
Reflow Zone	
Max slope	2–3 °C/s
Reflow time (D: over 220 °C)	45–70 s
Max temperature	238–246 °C
Cooling down slope	-1 to -4 °C/s
Reflow Cycle	
Max reflow cycle	1

8.3. Packaging

EC25 is packaged in tap and reel carriers. Each reel is 11.88 m long and contains 250 modules. The figure below shows the package details, measured in mm.

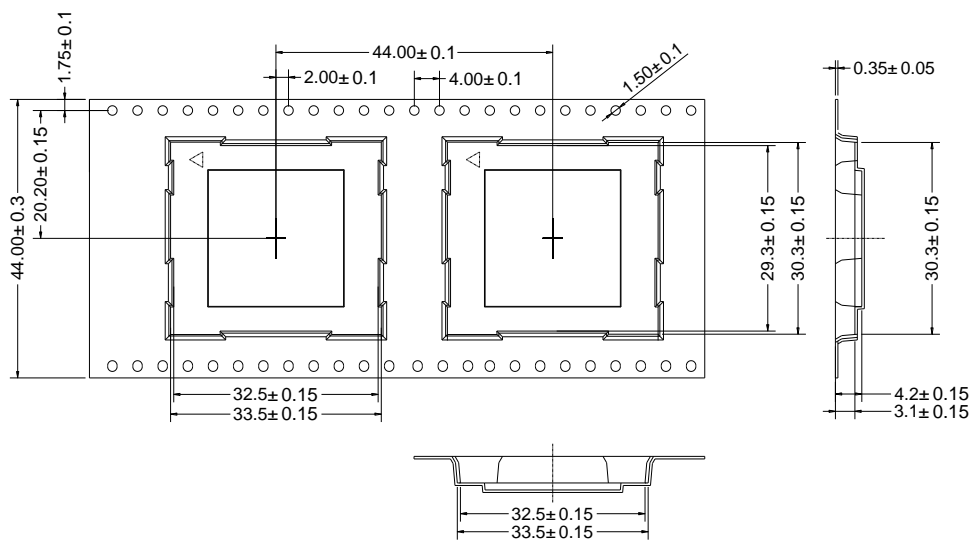

Figure 50: Tape Specifications

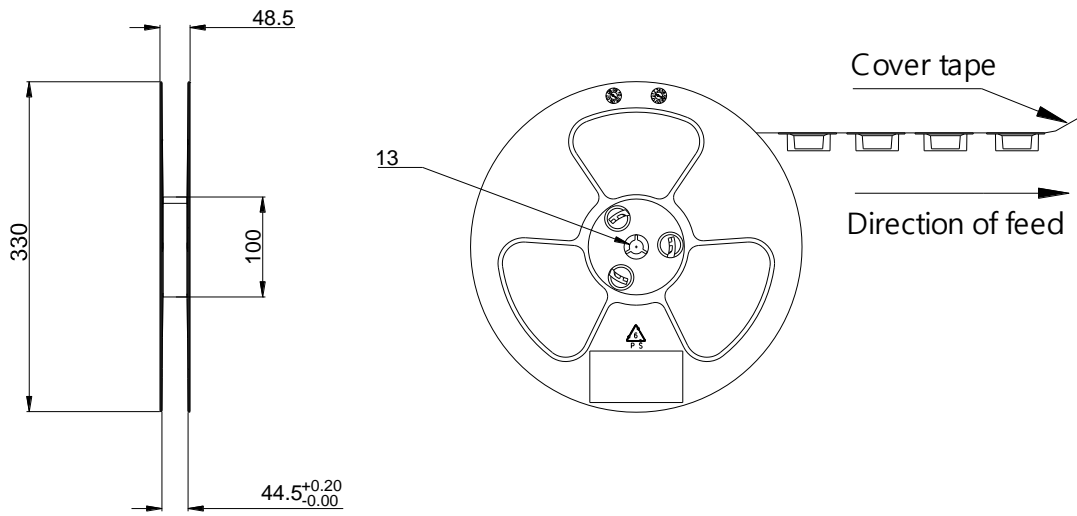

Figure 51: Reel Specifications

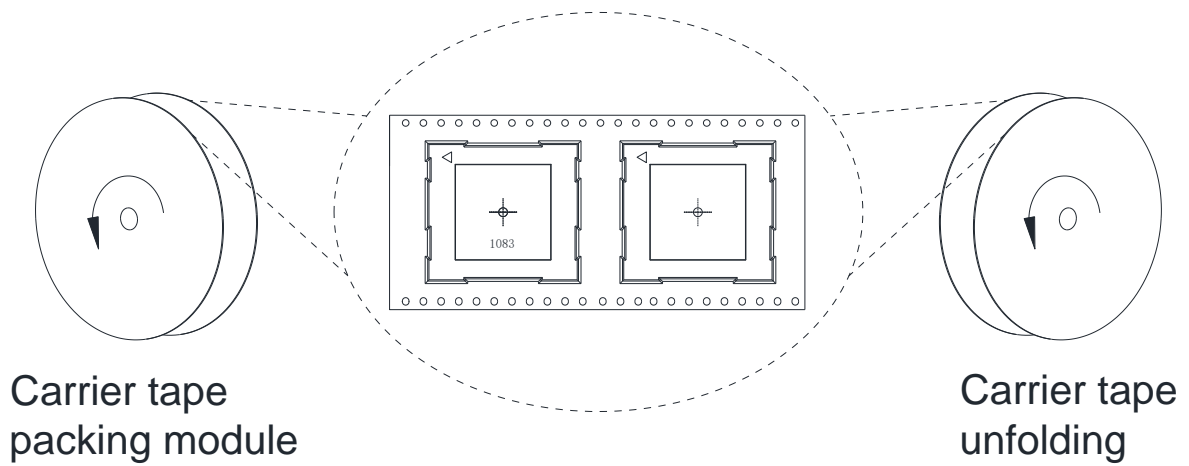

Figure 52: Tape and Reel Directions

9 Appendix A References

Table 70: Related Documents

SN	Document Name	Remark
[1]	Quectel_EC2x&EGxx_Power_Management_Application_Note	Power management application note for EC25, EC21, EC20 R2.0, EC20 R2.1, EG95, EG91 and EG25-G modules
[2]	Quectel_LTE_Standard_AT_Commands_Manual	AT commands manual for LTE Standard modules
[3]	Quectel_LTE_Standard_GNSS_AT_Commands_Manual	GNSS AT Commands Manual for LTE Standard modules
[4]	Quectel_Module_Secondary_SMT_User_Guide	Module secondary SMT user guide
[5]	Quectel_EC25_Reference_Design	EC25 reference design
[6]	Quectel_RF_Layout_Application_Note	RF layout application note
[7]	Quectel_LTE_Module_Thermal_Design_Guide	Thermal design guide for LTE standard, LTE-A and Automotive modules
[8]	Quectel_UMTS<E_EVB_User_Guide	UMTS & LTE EVB user guide for UMTS & LTE modules

Table 71: Terms and Abbreviations

Abbreviation	Description
AMR	Adaptive Multi-rate
bps	Bits Per Second
CHAP	Challenge Handshake Authentication Protocol
CS	Coding Scheme
CSD	Circuit Switched Data

CTS	Clear to Send
DC-HSPA+	Dual-carrier High Speed Packet Access
DFOTA	Delta Firmware Upgrade Over-The-Air
DL	Downlink
DTR	Data Terminal Ready
DTX	Discontinuous Transmission
EFR	Enhanced Full Rate
ESD	Electrostatic Discharge
FDD	Frequency Division Duplex
FR	Full Rate
GLONASS	GLObalnaya NAVigatsionnaya Sputnikovaya Sistema, the Russian Global Navigation Satellite System
GMSK	Gaussian Minimum Shift Keying
GNSS	Global Navigation Satellite System
GPS	Global Positioning System
GSM	Global System for Mobile Communications
HR	Half Rate
HSPA	High Speed Packet Access
HSDPA	High Speed Downlink Packet Access
HSUPA	High Speed Uplink Packet Access
I/O	Input/Output
Inorm	Normal Current
LED	Light Emitting Diode
LNA	Low Noise Amplifier
LTE	Long Term Evolution
MIMO	Multiple Input Multiple Output

MO	Mobile Originated
MS	Mobile Station (GSM engine)
MT	Mobile Terminated
PAP	Password Authentication Protocol
PCB	Printed Circuit Board
PDU	Protocol Data Unit
PPP	Point-to-Point Protocol
QAM	Quadrature Amplitude Modulation
QPSK	Quadrature Phase Shift Keying
RF	Radio Frequency
RHCP	Right Hand Circularly Polarized
Rx	Receive
SGMII	Serial Gigabit Media Independent Interface
SIM	Subscriber Identification Module
SIMO	Single Input Multiple Output
SMS	Short Message Service
TDD	Time Division Duplexing
TDMA	Time Division Multiple Access
TD-SCDMA	Time Division-Synchronous Code Division Multiple Access
TX	Transmitting Direction
UL	Uplink
UMTS	Universal Mobile Telecommunications System
URC	Unsolicited Result Code
(U)SIM	(Universal) Subscriber Identity Module
Vmax	Maximum Voltage Value

Vnorm	Normal Voltage Value
Vmin	Minimum Voltage Value
V _{IHmax}	Maximum Input High Level Voltage Value
V _{IHmin}	Minimum Input High Level Voltage Value
V _{ILmax}	Maximum Input Low Level Voltage Value
V _{ILmin}	Minimum Input Low Level Voltage Value
V _{Imax}	Absolute Maximum Input Voltage Value
V _{Imin}	Absolute Minimum Input Voltage Value
V _{OHmax}	Maximum Output High Level Voltage Value
V _{OHmin}	Minimum Output High Level Voltage Value
V _{OLmax}	Maximum Output Low Level Voltage Value
V _{OLmin}	Minimum Output Low Level Voltage Value
VSWR	Voltage Standing Wave Ratio
WCDMA	Wideband Code Division Multiple Access
WLAN	Wireless Local Area Network

10 Appendix B GPRS Coding Schemes

Table 72: Description of Different Coding Schemes

Scheme	CS-1	CS-2	CS-3	CS-4
Code Rate	1/2	2/3	3/4	1
USF	3	3	3	3
Pre-coded USF	3	6	6	12
Radio Block excl.USF and BCS	181	268	312	428
BCS	40	16	16	16
Tail	4	4	4	-
Coded Bits	456	588	676	456
Punctured Bits	0	132	220	-
Data Rate Kb/s	9.05	13.4	15.6	21.4

11 Appendix C GPRS Multi-slot Classes

Thirty-three classes of GPRS multi-slot modes are defined for MS in GPRS specification. Multi-slot classes are product dependent, and determine the maximum achievable data rates in both the uplink and downlink directions. Written as 3 + 1 or 2 + 2, the first number indicates the amount of downlink timeslots, while the second number indicates the amount of uplink timeslots. The active slots determine the total number of slots the GPRS device can use simultaneously for both uplink and downlink communications.

The description of different multi-slot classes is shown in the following table.

Table 73: GPRS Multi-slot Classes

Multislot Class	Downlink Slots	Uplink Slots	Active Slots
1	1	1	2
2	2	1	3
3	2	2	3
4	3	1	4
5	2	2	4
6	3	2	4
7	3	3	4
8	4	1	5
9	3	2	5
10	4	2	5
11	4	3	5
12	4	4	5
13	3	3	NA
14	4	4	NA

15	5	5	NA
16	6	6	NA
17	7	7	NA
18	8	8	NA
19	6	2	NA
20	6	3	NA
21	6	4	NA
22	6	4	NA
23	6	6	NA
24	8	2	NA
25	8	3	NA
26	8	4	NA
27	8	4	NA
28	8	6	NA
29	8	8	NA
30	5	1	6
31	5	2	6
32	5	3	6
33	5	4	6

12 Appendix D EDGE Modulation and Coding Schemes

Table 74: EDGE Modulation and Coding Schemes

Coding Scheme	Modulation	Coding Family	1 Timeslot	2 Timeslot	4 Timeslot
MCS-1	GMSK	C	8.80 kbps	17.60 kbps	35.20 kbps
MCS-2	GMSK	B	11.2 kbps	22.4 kbps	44.8 kbps
MCS-3	GMSK	A	14.8 kbps	29.6 kbps	59.2 kbps
MCS-4	GMSK	C	17.6 kbps	35.2 kbps	70.4 kbps
MCS-5	8-PSK	B	22.4 kbps	44.8 kbps	89.6 kbps
MCS-6	8-PSK	A	29.6 kbps	59.2 kbps	118.4 kbps
MCS-7	8-PSK	B	44.8 kbps	89.6 kbps	179.2 kbps
MCS-8	8-PSK	A	54.4 kbps	108.8 kbps	217.6 kbps
MCS-9	8-PSK	A	59.2 kbps	118.4 kbps	236.8 kbps