

BC660K-GL

Hardware Design

NB-IoT Module Series

Version: 1.0.0

Date: 2020-11-20

Status: Preliminary



Our aim is to provide customers with timely and comprehensive service. For any assistance, please contact our company headquarters:

Quectel Wireless Solutions Co., Ltd.

Building 5, Shanghai Business Park Phase III (Area B), No.1016 Tianlin Road, Minhang District, Shanghai 200233, China

Tel: +86 21 5108 6236

Email: info@quectel.com

Or our local office. For more information, please visit:

<http://www.quectel.com/support/sales.htm>.

For technical support, or to report documentation errors, please visit:

<http://www.quectel.com/support/technical.htm>

Or email to support@quectel.com.

General Notes

Quectel offers the information as a service to its customers. The information provided is based upon customers' requirements. Quectel makes every effort to ensure the quality of the information it makes available. Quectel does not make any warranty as to the information contained herein, and does not accept any liability for any injury, loss or damage of any kind incurred by use of or reliance upon the information. All information supplied herein is subject to change without prior notice.

Disclaimer

While Quectel has made efforts to ensure that the functions and features under development are free from errors, it is possible that these functions and features could contain errors, inaccuracies and omissions. Unless otherwise provided by valid agreement, Quectel makes no warranties of any kind, implied or express, with respect to the use of features and functions under development. To the maximum extent permitted by law, Quectel excludes all liability for any loss or damage suffered in connection with the use of the functions and features under development, regardless of whether such loss or damage may have been foreseeable.

Duty of Confidentiality

The Receiving Party shall keep confidential all documentation and information provided by Quectel, except when the specific permission has been granted by Quectel. The Receiving Party shall not access or use Quectel's documentation and information for any purpose except as expressly provided herein. Furthermore, the Receiving Party shall not disclose any of the Quectel's documentation and information to any third party without the prior written consent by Quectel. For any noncompliance to the above requirements, unauthorized use, or other illegal or malicious use of the documentation and information, Quectel will reserve the right to take legal action.

Copyright

The information contained here is proprietary technical information of Quectel wireless solutions co., ltd. Transmitting, reproducing, disseminating and editing this document as well as using the content without permission are forbidden. Offenders will be held liable for payment of damages. All rights are reserved in the event of a patent grant or registration of a utility model or design.

Copyright © Quectel Wireless Solutions Co., Ltd. 2020. All rights reserved.

About the Document

Revision History

Version	Date	Author	Description
-	2020-09-30	Clifton HE/ Ellison WANG/ Randy LI	Creation of the document
1.0.0	2020-11-20	Clifton HE/ Ellison WANG/ Randy LI	Preliminary

Contents

About the Document	3
Contents	4
Table Index	6
Figure Index	7
1 Introduction	8
1.1. Safety Information.....	9
2 Product Concept	10
2.1. General Description.....	10
2.2. Key Features.....	11
2.3. Functional Diagram.....	12
2.4. Evaluation Board.....	13
3 Application Interfaces	14
3.1. Pin Assignment.....	15
3.2. Pin Description.....	16
3.3. Operating Modes.....	20
3.4. Power Saving.....	21
3.4.1. Light Sleep.....	21
3.4.2. Deep Sleep.....	21
3.5. Power Supply.....	22
3.5.1. Power Supply Pins.....	22
3.5.2. Reference Design for Power Supply.....	23
3.5.3. Power Supply Voltage Detection*.....	23
3.6. Power-up/Power-down Scenarios.....	24
3.6.1. Power-up.....	24
3.6.2. Power-down.....	25
3.6.3. Reset.....	25
3.6.4. Download.....	26
3.7. UART Interfaces.....	27
3.7.1. Main UART Port.....	28
3.7.2. Debug UART Port.....	28
3.7.3. UART Application.....	29
3.8. (U)SIM Interface.....	31
3.9. ADC Interface*.....	33
3.10. RI Interface*.....	33
3.11. NETLIGHT Interface*.....	34
4 Antenna Interface	36
4.1. Pin Definition.....	36
4.2. Operating Frequencies.....	36
4.3. RF Antenna Reference Design.....	37

4.4.	Reference Design of RF Layout.....	38
4.5.	Antenna Requirements.....	40
4.6.	RF Output Power.....	41
4.7.	RF Receiving Sensitivity.....	42
4.8.	Recommended RF Connector for Antenna Installation.....	43
5	Reliability and Electrical Characteristics.....	45
5.1.	Operating and Storage Temperatures.....	45
5.2.	Current Consumption.....	46
5.3.	Electrostatic Discharge.....	48
6	Mechanical Features.....	49
6.1.	Mechanical Dimensions.....	49
6.2.	Recommended Footprint.....	51
6.3.	Top and Bottom Views.....	52
7	Storage, Manufacturing and Packaging.....	53
7.1.	Storage.....	53
7.2.	Manufacturing and Soldering.....	54
7.3.	Tape and Reel Packaging.....	55
8	Appendix A References.....	57

Table Index

Table 1: Frequency Bands of BC660K-GL.....	10
Table 2: BC660K-GL Key Features.....	11
Table 3: I/O Parameters Definition.....	16
Table 4: Pin Description.....	16
Table 5: AP Operating Modes.....	20
Table 6: Modem Operating Modes.....	20
Table 7: Module Operating Modes.....	20
Table 8: Power Supply Pins.....	23
Table 9: Reset Pin Definition.....	25
Table 10: Pin Definition of UART Interfaces.....	27
Table 11: Pin Definition of (U)SIM Interface.....	31
Table 12: Pin Definition of ADC Interface.....	33
Table 13: RI Signal Status.....	33
Table 14: Pin Definition of NB-IoT Antenna Interface.....	36
Table 15: Module Operating Frequencies.....	36
Table 16: Antenna Cable Insertion Loss Requirements.....	40
Table 17: Required Antenna Parameters.....	40
Table 18: RF Conducted Output Power.....	41
Table 19: Receiving Sensitivity (with RF Retransmissions).....	42
Table 20: Operation and Storage Temperatures.....	45
Table 21: Module Current Consumption (3.3 V VBAT Power Supply).....	46
Table 22: Electrostatic Discharge Characteristics (25 °C, 45 % Relative Humidity).....	48
Table 23: Recommended Thermal Profile Parameters.....	55
Table 24: Related Documents.....	57
Table 25: Terms and Abbreviations.....	57

Figure Index

Figure 1: Functional Diagram.....	13
Figure 2: Pin Assignment.....	15
Figure 3: Module Power Consumption in Different Modes (Modem).....	21
Figure 4: Timing of Waking up Module from PSM.....	22
Figure 5: Reference Circuit for Power Supply.....	23
Figure 6: Power-up Timing.....	24
Figure 7: Power-down Timing.....	25
Figure 8: Reference Circuit of RESET_N by Using Driving Circuit.....	25
Figure 9: Reference Circuit of RESET_N by Using Button.....	26
Figure 10: Reference Circuit of BOOT by Using Button.....	27
Figure 11: Reference Design for Main UART Port.....	28
Figure 12: Reference Design of Debug UART Port.....	28
Figure 13: Reference Circuit Design of UART.....	29
Figure 14: Sketch Map for RS-232 Interface Match.....	30
Figure 15: Reference Circuit with Transistor Circuit.....	31
Figure 16: Reference Circuit for (U)SIM Interface with a 6-pin (U)SIM Card Connector.....	32
Figure 17: RI Behaviour When a URC is Received.....	34
Figure 18: Reference Design of NETLIGHT.....	35
Figure 19: Reference Design of NB-IoT Antenna Interface.....	38
Figure 20: Microstrip Design on a 2-layer PCB.....	38
Figure 21: Coplanar Waveguide Design on a 2-layer PCB.....	39
Figure 22: Coplanar Waveguide Design on a 4-layer PCB (Layer 3 as Reference Ground).....	39
Figure 23: Coplanar Waveguide Design on a 4-layer PCB (Layer 4 as Reference Ground).....	39
Figure 24: Dimensions of the U.FL-R-SMT Connector (Unit: mm).....	43
Figure 25: Mechanicals of U.FL-LP Connectors.....	43
Figure 26: Space Factor of Mated Connector (Unit: mm).....	44
Figure 27: BC660K-GL Top and Side Dimensions (Unit: mm).....	49
Figure 28: Module Bottom Dimension (Bottom View).....	50
Figure 29: Recommended Footprint (Unit: mm).....	51
Figure 30: Top View of the Module.....	52
Figure 31: Bottom View of the Module.....	52
Figure 32: Recommended Reflow Soldering Thermal Profile.....	54
Figure 33: Tape Dimensions (Unit: mm).....	56
Figure 34: Reel Dimensions (Unit: mm).....	56

1 Introduction

This document defines the BC660K-GL module and describes its air interfaces and hardware interface which are connected with the customers' applications.

This document helps customers quickly understand the interface specifications, electrical and mechanical details, as well as other related information of the module. To facilitate application designs, it also includes some reference designs for customers' reference. The document, coupled with application notes and user guides, makes it easy to design and set up mobile applications with BC660K-GL.

1.1. Safety Information

The following safety precautions must be observed during all phases of operation, such as usage, service or repair of any cellular terminal or mobile incorporating the module. Manufacturers of the cellular terminal should notify users and operating personnel of the following safety information by incorporating these guidelines into all manuals of the product. Otherwise, Quectel assumes no liability for customers' failure to comply with these precautions.



Full attention must be paid to driving at all times in order to reduce the risk of an accident. Using a mobile while driving (even with a handsfree kit) causes distraction and can lead to an accident. Please comply with laws and regulations restricting the use of wireless devices while driving.



Switch off the cellular terminal or mobile before boarding an aircraft. The operation of wireless appliances in an aircraft is forbidden to prevent interference with communication systems. If there is an Airplane Mode, it should be enabled prior to boarding an aircraft. Please consult the airline staff for more restrictions on the use of wireless devices on an aircraft.



Wireless devices may cause interference on sensitive medical equipment, so please be aware of the restrictions on the use of wireless devices when in hospitals, clinics or other healthcare facilities.



Cellular terminals or mobiles operating over radio signals and cellular network cannot be guaranteed to connect in all possible conditions (for example, with unpaid bills or with an invalid (U)SIM card). When emergency help is needed in such conditions, please remember using emergency call. In order to make or receive a call, the cellular terminal or mobile must be switched on in a service area with adequate cellular signal strength.



The cellular terminal or mobile contains a transmitter and receiver. When it is ON, it receives and transmits radio frequency signals. RF interference can occur if it is used close to TV set, radio, computer or other electric equipment.



In locations with potentially explosive atmospheres, obey all posted signs to turn off wireless devices such as mobile phone or other cellular terminals. Areas with potentially explosive atmospheres include fuelling areas, below decks on boats, fuel or chemical transfer or storage facilities, areas where the air contains chemicals or particles such as grain, dust or metal powders, etc.

2 Product Concept

2.1. General Description

BC660K-GL is a high-performance NB-IoT module with extremely low power consumption. It is designed to communicate with infrastructures of mobile network operators through NB-IoT radio protocols (3GPP Rel-13 and 3GPP Rel-14). BC660K-GL supports a broad range of frequency bands as listed below.

Table 1: Frequency Bands of BC660K-GL

Mode	BC660K-GL
H-FDD	B1/B2/B3/B4/B5/B8/B12/B13/ B17/B18/B19/B20/B25/B28/B66/B70/B85

BC660K-GL is an SMD type module with LCC and LGA package, and has an ultra-compact profile of 17.7 mm × 15.8 mm × 2.0 mm, which makes it easily embedded into size-constrained applications and provide reliable connectivity with the applications.

BC660K-GL provides abundant external interfaces (UART, ADC, (U)SIM, etc) and protocol stacks (UDP/TCP/LwM2M*/MQTT*, etc.), which provide great convenience for customers' applications.

Due to compact form factor, ultra-low power consumption and extended temperature range, BC660K-GL is a best choice for a wide range of IoT applications, such as smart metering, bike sharing, smart wearables, smart parking, smart city, home appliances, security and asset tracking, agricultural and environmental monitoring, etc. It is able to provide a complete range of SMS* and data transmission services to meet customers' demands.

The module fully complies with the RoHS directive of the European Union.

NOTE

“*” means under development.

2.2. Key Features

The following table describes the detailed features of BC660K-GL module.

Table 2: BC660K-GL Key Features

Feature	Details
Power Supply	<ul style="list-style-type: none"> ● Supply voltage: 2.2–4.3 V ● Typical supply voltage: 3.3 V
Power Saving	<ul style="list-style-type: none"> ● Typical power consumption: 800 nA
Frequency Bands	<p>LTE Cat NB2:</p> <ul style="list-style-type: none"> ● B1/B2/B3/B4/B5/B8/B12/B13/B17/B18/B19/B20/B25/B28/B66/B70/B85
Transmitting Power	<ul style="list-style-type: none"> ● 23 dBm ±2 dB
(U)SIM Interface	<ul style="list-style-type: none"> ● Support 1.8/3.0 V (U)SIM card
UART Interfaces	<p>Main UART Port:</p> <ul style="list-style-type: none"> ● Used for AT command communication and data transmission, the baud rate is 115200 bps by default. For more details, see Chapter 3.7.1. ● Used for firmware upgrade, and in such case, the baud rate is 921600 bps by default. <p>Debug UART Port:</p> <ul style="list-style-type: none"> ● Used for firmware debugging ● Default baud rate: 6 Mbps
Network Protocols	<ul style="list-style-type: none"> ● UDP/TCP/SNTP/LwM2M*/MQTT*/TLS*/DTLS*
SMS*	<ul style="list-style-type: none"> ● Text/PDU Mode
Data Transmission Features	<ul style="list-style-type: none"> ● Single-tone (max): 25.5 kbps (DL)/16.7 kbps (UL) ● Multi-tone (max): 127 kbps (DL)/158.5 kbps (UL)
AT Commands	<ul style="list-style-type: none"> ● 3GPP TS 27.005/3GPP TS 27.007 AT commands (3GPP Rel-13 and 3GPP Rel-14) and Quectel enhanced AT commands
Firmware Update	<ul style="list-style-type: none"> ● Upgrade firmware via main UART port ● Upgrade firmware via DFOTA
Real Time Clock	<ul style="list-style-type: none"> ● Supported
Physical Characteristics	<ul style="list-style-type: none"> ● Size: (17.7 ±0.15) mm × (15.8 ±0.15) mm × (2.0 ±0.2) mm ● Weight: 1.0 ±0.2 g
Temperature Range	<ul style="list-style-type: none"> ● Operating temperature range: -35 to +75 °C ¹⁾ ● Extended temperature range: -40 to +85 °C ²⁾ ● Storage temperature range: -40 to +90 °C

Antenna Interface	● 50 Ω impedance control
RoHS	● All hardware components are fully compliant with EU RoHS directive

NOTES

- 1) Within operating temperature range, the module is 3GPP compliant.
- 2) Within extended temperature range, the module remains the ability to establish and maintain functions such as SMS* and data transmission, without any unrecoverable malfunction. Radio spectrum and radio network will not be influenced, while one or more specifications, such as P_{out} , may exceed the specified tolerances of 3GPP. When the temperature returns to the normal operation temperature levels, the module will meet 3GPP specifications again.
3. "*" means under development.

2.3. Functional Diagram

The following figure shows a block diagram of BC660K-GL and illustrates the major functional parts.

- Radio frequency
- Baseband
- Power management
- Peripheral interfaces

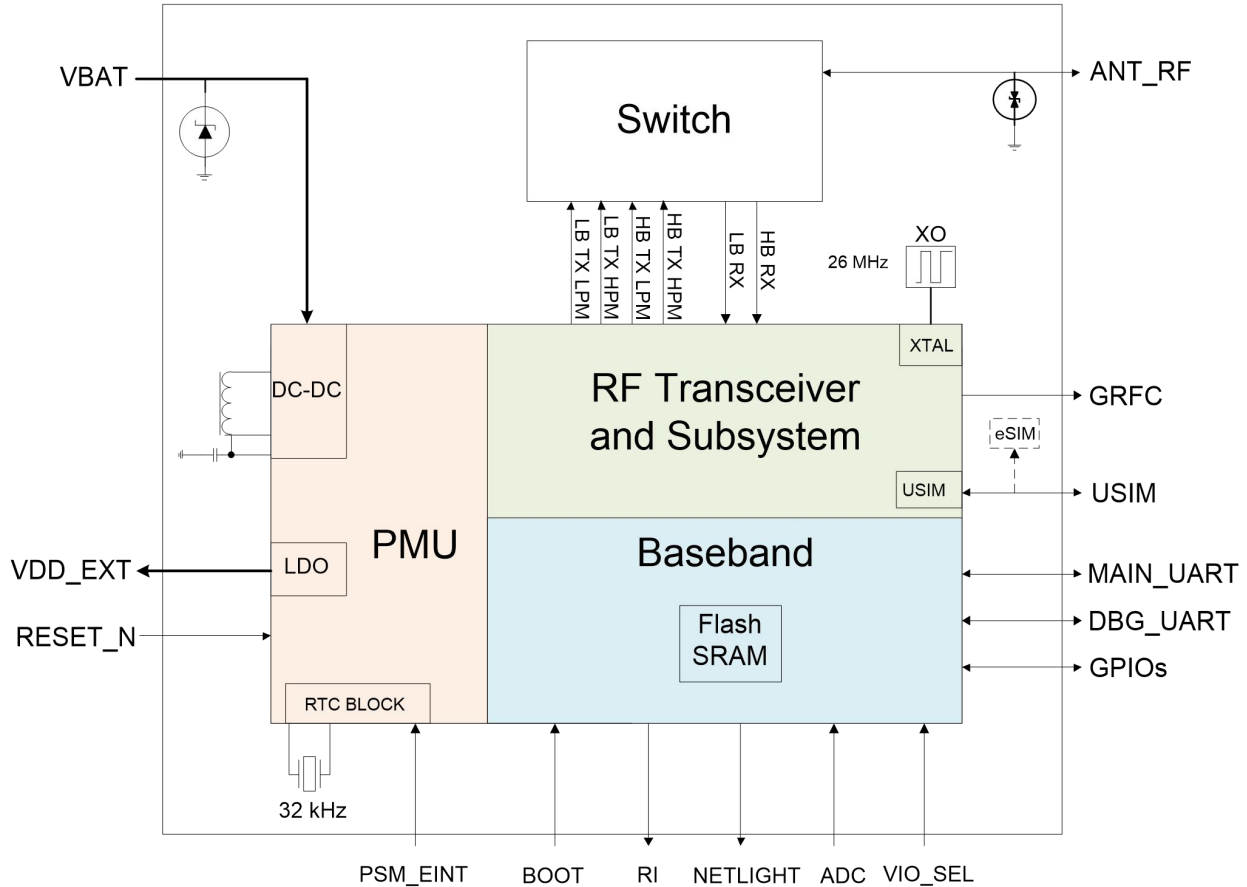

Figure 1: Functional Diagram

2.4. Evaluation Board

Quectel provides a complete set of development tools to facilitate the use and testing of BC660K-GL module. The development tool kit includes the TE-B board, a USB cable, an antenna and other peripherals. For more details, see *document [1]*.

3 Application Interfaces

BC660K-GL is equipped with a total of 58 pins, including 44 LCC pins and 14 LGA pins. The subsequent chapters will provide detailed descriptions of the following functions/pins/interfaces:

- Power Supply
- PSM_EINT
- RESET_N
- BOOT
- UART Interfaces
- (U)SIM Interface
- ADC Interface*
- RI Interface*
- NETLIGHT Interface*

NOTE

"*" means under development.

3.1. Pin Assignment

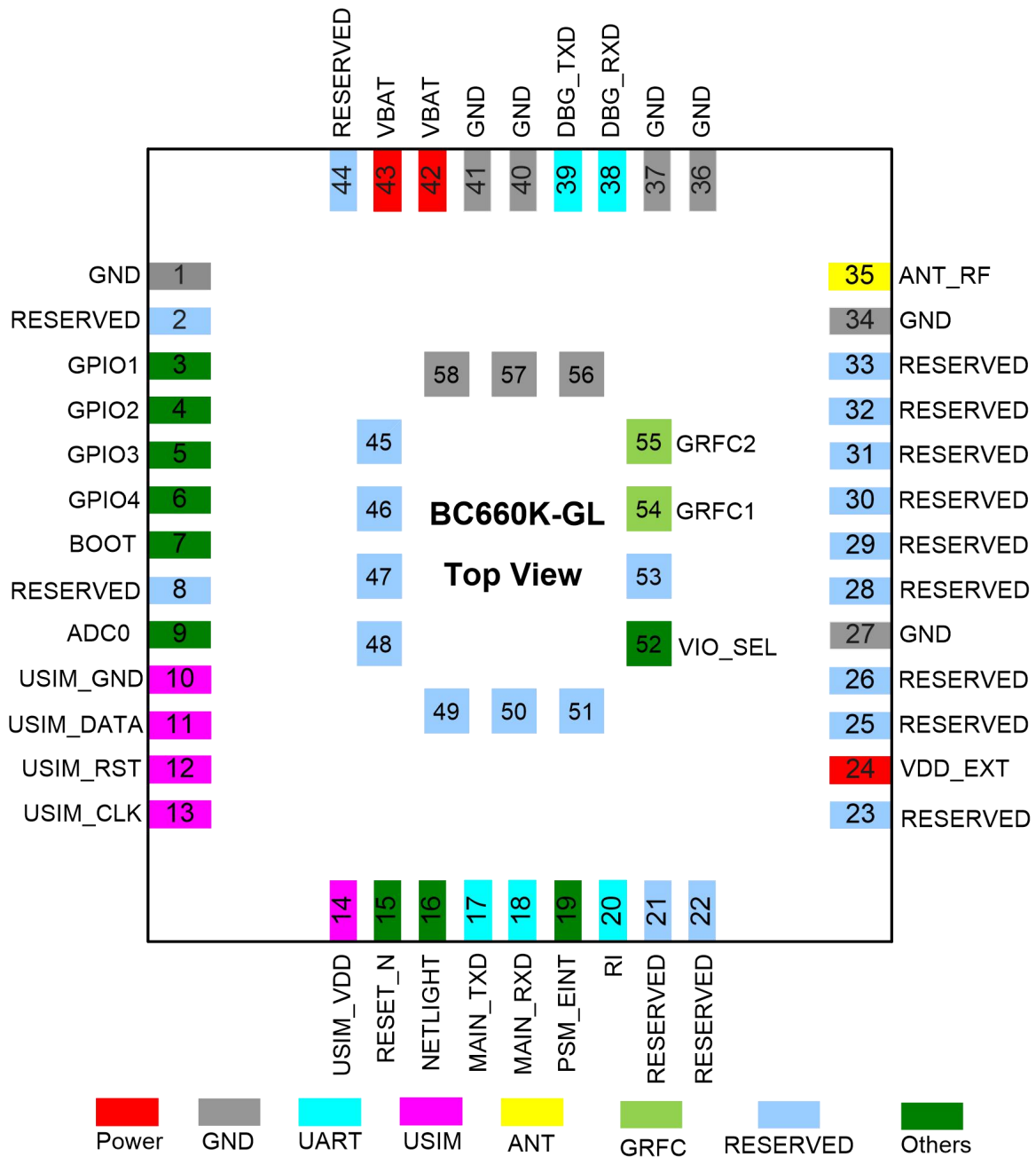

Figure 2: Pin Assignment

NOTE

Keep all reserved and unused pins unconnected.

3.2. Pin Description

Table 3: I/O Parameters Definition

Type	Description
AI	Analog input
AO	Analog output
DI	Digital input
DO	Digital output
IO	Bidirectional
PI	Power input
PO	Power output

Table 4: Pin Description

Power Supply						
Pin Name	Pin No.	I/O	Description	DC Characteristics	Comment	
VBAT	42, 43	PI	Power supply for the module	Vmax = 4.3 V Vmin = 2.2 V Vnorm = 3.3 V		
VDD_EXT	24	PO	1.8/3.3 V output for external circuit	Vnorm = 1.8/3.3 V	No voltage output in Deep Sleep/Light Sleep mode. It is intended to supply power for the module's pull-up circuits, and is not recommended to be used as the power supply for external circuits.	
GND	1, 27, 34, 36, 37, 40, 41, 56, 57, 58					
Power Key Interface						
Pin Name	Pin No.	I/O	Description	DC Characteristics	Comment	

BOOT	7	DI	Control module enter download mode	$V_{ILmax} = 0.2 \times VDD_EXT$ $V_{IHmin} = 0.7 \times VDD_EXT$	Active low.
Reset Interface					
Pin Name	Pin No.	I/O	Description	DC Characteristics	Comment
RESET_N	15	DI	Reset the module	$V_{ILmax} = 0.38\text{ V}$ $V_{IHmin} = 1.33\text{ V}$ $V_{IHmax} = 3.6\text{ V}$	Active low.
PSM_EINT Interface					
Pin Name	Pin No.	I/O	Description	DC Characteristics	Comment
PSM_EINT	19	DI	Dedicated external interrupt pin used to wake up the module from Deep Sleep/Light Sleep mode..	$V_{ILmax} = 0.38\text{ V}$ $V_{IHmin} = 1.33\text{ V}$ $V_{IHmax} = 3.6\text{ V}$	Active on falling edge.
Network Status Indication*					
Pin Name	Pin No.	I/O	Description	DC Characteristics	Comment
NETLIGHT	16	DO	Indicate the module's network activity status	$V_{OLmax} = 0.15 \times VDD_EXT$ $V_{OHmin} = 0.8 \times VDD_EXT$	
ADC Interface*					
Pin Name	Pin No.	I/O	Description	DC Characteristics	Comment
ADC0	9	AI	General-purpose analog to digital converter interface	Voltage range: 0–1.2 V	
Main UART Port					
Pin Name	Pin No.	I/O	Description	DC Characteristics	Comment
MAIN_RXD	18	DI	Main UART receive	$V_{ILmax} = 0.2 \times VDD_EXT$ $V_{IHmin} = 0.7 \times VDD_EXT$	
MAIN_TXD	17	DO	Main UART transmit	$V_{OLmax} = 0.15 \times VDD_EXT$ $V_{OHmin} = 0.8 \times VDD_EXT$	VDD_EXT power domain.

Debug UART Port					
Pin Name	Pin No.	I/O	Description	DC Characteristics	Comment
DBG_RXD	38	DI	Debug UART receive	$V_{ILmax} = 0.2 \times VDD_EXT$ $V_{IHmin} = 0.7 \times VDD_EXT$	VDD_EXT power domain.
DBG_TXD	39	DO	Debug UART transmit	$V_{OLmax} = 0.15 \times VDD_EXT$ $V_{OHmin} = 0.8 \times VDD_EXT$	
Ringing Signal*					
Pin Name	Pin No.	I/O	Description	DC Characteristics	Comment
RI	20	DO	Ring indication	$V_{OLmax} = 0.15 \times VDD_EXT$ $V_{OHmin} = 0.8 \times VDD_EXT$	VDD_EXT power domain.
(U)SIM Interface					
Pin Name	Pin No.	I/O	Description	DC Characteristics	Comment
(U)SIM_VDD	14	DO	(U)SIM card power supply	$V_{norm} = 1.8/3.0\text{ V}$	
(U)SIM_RST	12	DO	(U)SIM card reset	$V_{OLmax} = 0.15 \times (U)SIM_VDD$ $V_{OHmin} = 0.8 \times (U)SIM_VDD$	
(U)SIM_DAT A	11	IO	(U)SIM card data	$V_{ILmax} = 0.2 \times (U)SIM_VDD$ $V_{IHmin} = 0.7 \times (U)SIM_VDD$ $V_{OLmax} = 0.15 \times (U)SIM_VDD$ $V_{OHmin} = 0.8 \times (U)SIM_VDD$	
(U)SIM_CLK	13	DO	(U)SIM card clock	$V_{OLmax} = 0.15 \times (U)SIM_VDD$ $V_{OHmin} = 0.8 \times (U)SIM_VDD$	
(U)SIM_GND	10		Specified ground for (U)SIM card		
Antenna Interface					
Pin Name	Pin No.	I/O	Description	DC Characteristics	Comment
ANT_RF	35	IO	RF antenna interface		50 Ω characteristic impedance
GPIO Interfaces					
Pin Name	Pin No.	I/O	Description	DC Characteristics	Comment
GPIO1	3	IO	General-purpose input/output	$V_{ILmax} = 0.2 \times VDD_EXT$ $V_{IHmin} = 0.7 \times VDD_EXT$	VDD_EXT power domain.
GPIO2	4	IO	General-purpose input/output	$V_{OLmax} = 0.15 \times VDD_EXT$ $V_{OHmin} = 0.8 \times VDD_EXT$	

GPIO3	5	IO	General-purpose input/output		If unused, keep these pins open.
GPIO4	6	IO	General-purpose input/output		

GRFC Interfaces

Pin Name	Pin No.	I/O	Description	DC Characteristics	Comment
GRFC1	54	DO	Generic RF controller		1.8 V power domain.
GRFC2	55	DO	Generic RF controller		If unused, keep these pins open.

Other Interface Pin

Pin Name	Pin No.	I/O	Description	DC Characteristics	Comment
VIO_SEL	52	DI	IO Voltage selection Floating: 1.8 V 0: 3.3 V		Control VDD_EXT voltage select 1.8 V or 3.3 V

Reserved Pins

Pin Name	Pin No.	I/O	Description	DC Characteristics	Comment
RESERVED	2, 8, 21–23, 25, 26, 28–33, 44–51, 53				Keep these pins open.

NOTES

1. Keep all reserved and unused pins unconnected.
2. When VIO_SEL is grounded and VBAT < 3.3 V, VDD_EXT = VBAT;
When VIO_SEL is grounded and VBAT ≥ 3.3 V, VDD_EXT = 3.3 V;
When VIO_SEL is floating, VDD_EXT = 1.8 V.
3. “*” means under development.

3.3. Operating Modes

The following table describes the three working modes of the module briefly.

Table 5: AP Operating Modes

Mode	Description
Normal	In normal mode, the AP handles tasks, such as AT command communication.
Idle	When all tasks are suspended, the AP will enter idle mode.

Table 6: Modem Operating Modes

Mode	Description
Connected	The network is connected and the module supports data transmission. In such a case, the modem can switch to DRX/eDRX mode.
DRX/eDRX	The modem is in idle mode, and downlink data can be received during PTW only. In such a case, the modem can switch to PSM or connected mode.
PSM	In power saving mode, the modem is disconnected from the network and cannot receive any downlink data. In such a case, the modem can switch to eDRX/DRX.

Table 7: Module Operating Modes

Mode	Description
Active	When the AP is in normal mode or the modem is in connected mode, the module will be active and supports all services and functions. The current consumption in active mode is higher than that in sleep modes.
Light Sleep	Generally, when the AP is in idle mode and the modem is in DRX/eDRX mode, the module will enter Light Sleep mode. In such a case, the AP tasks will be suspended and the modem will be able to receive downlink data during PTW only. In Light Sleep mode, the current consumption of the module is reduced greatly.
Deep Sleep	When the AP is in idle mode and the modem is idle or inactive, the module will enter deep sleep mode in which the CPU is powered off and only the 32 kHz RTC clock is working. In deep sleep mode, the current consumption will be reduced to the minimum (typical value: 800 nA).

3.4. Power Saving

Upon system requirement, there are several ways to drive the module to enter low current consumption status.

3.4.1. Light Sleep

In Light Sleep mode, the serial port does not work, and the module can be woken up through the falling edge of PSM_EINT.

In this mode, the UART port is inactive and the module can be awakened through the main UART port.

3.4.2. Deep Sleep

The module consumes extremely low current in Deep Sleep mode (typical value: 800 nA). The main purpose of Deep Sleep is to reduce the power consumption of the module and prolong the power supply time of the battery.

In Deep Sleep mode, the serial port does not work. The following figure shows the power consumption diagram of the module in different modes.

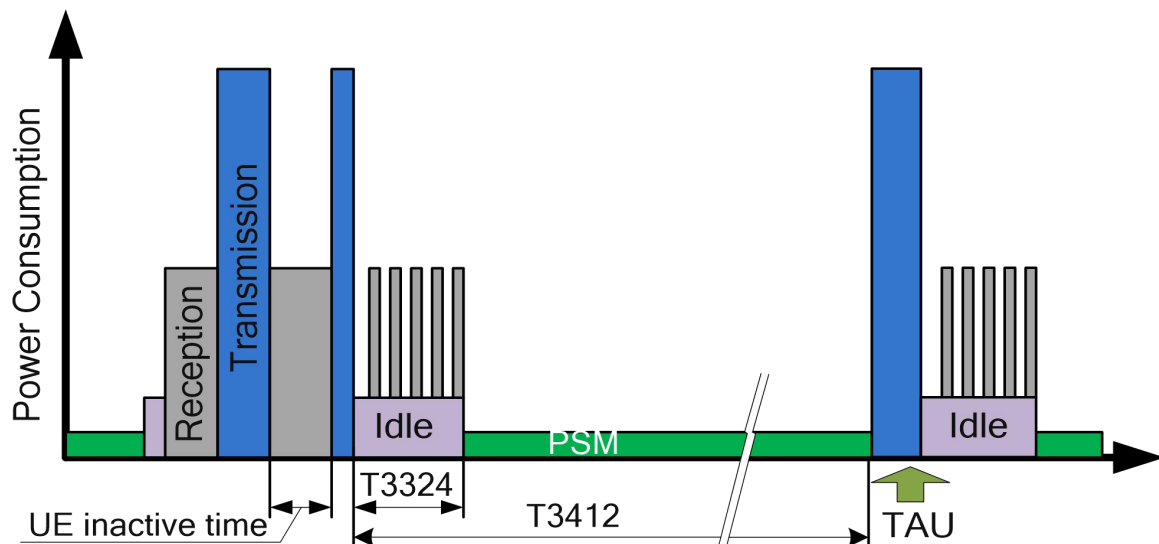

Figure 3: Module Power Consumption in Different Modes (Modem)

When the modem remains in PSM and the AP is in idle mode, the module will enter deep sleep mode. The procedure of the modem entering PSM is as follows:

The modem requests to enable PSM in **ATTACH REQUEST** or **TAU REQUEST** message during ATTACH/TAU (Tracking Area Update) procedure. Then the network accepts the request and provides an active time value (T3324) to the modem and the mobile reachable timer starts. When the T3324 timer expires, the modem enters PSM for the duration of T3412 (periodic TAU timer). Please note that the module cannot request entering PSM when it is establishing an emergency attachment or initializing the PDN (Public Data Network) connection

When the module is in deep sleep mode, it will be woken up in the following cases:

- After the T3412 timer expires, the module will exit deep sleep automatically.
- Send an AT command to the module (this AT command will be lost), pull down the MAIN_RXD, and in falling edge, the module will be woken up from deep sleep.
- Pulling down PSM_EINT (falling edge) will wake up the module from deep sleep.

The timing of waking up the module from PSM is illustrated below.

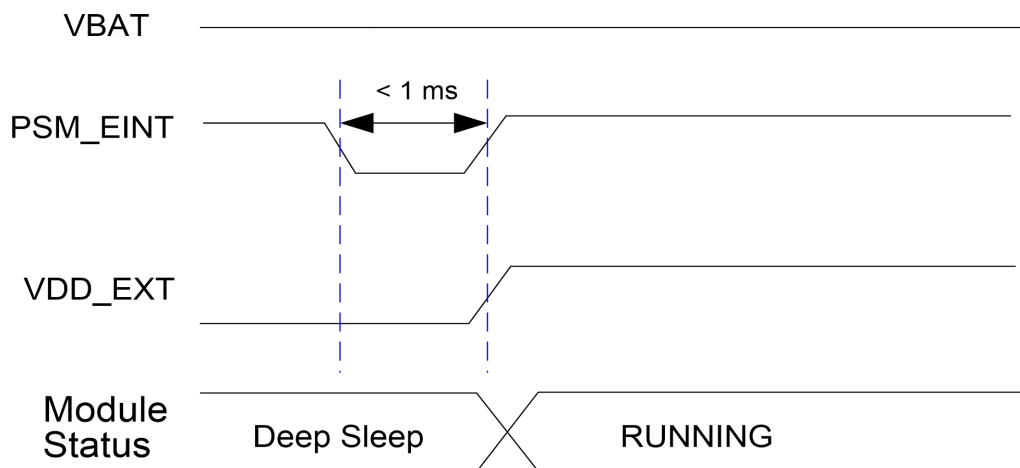

Figure 4: Timing of Waking up Module from PSM

3.5. Power Supply

3.5.1. Power Supply Pins

The module provides two VBAT pins for connection with an external power supply. The table below describes the module's VBAT and ground pins.

Table 8: Power Supply Pins

Pin Name	Pin No.	Description	Min.	Typ.	Max.	Unit
VBAT	42, 43	Power supply for the module	2.2	3.3	4.3	V
GND	1, 27, 34, 36, 37, 40, 41, 56, 57, 58	GND				

3.5.2. Reference Design for Power Supply

Power design for a module is critical to its performance. It is recommended to use a low quiescent current LDO with output current capacity of 0.5 A as the power supply for BC660K-GL. Lithium-thionyl chloride (Li-SOCl₂) batteries and Lithium manganese oxide (LiMn₂O₄) batteries can also be used as the power supply. The supply voltage of the module ranges from 2.2 V to 4.3 V. When the module is working, ensure its input voltage will never drop below 2.2 V; otherwise the module will be abnormal.

For better power performance, it is recommended to place a 100 μ F tantalum capacitor with low ESR (ESR = 0.7 Ω) and three ceramic capacitors (100 nF, 100 pF and 22 pF) near the VBAT pins. Also, it is recommended to add a TVS diode on the VBAT trace (near VBAT pins) to improve surge voltage withstand capability. In principle, the longer the VBAT trace is, the wider it should be. A reference circuit for power supply is illustrated in the following figure.

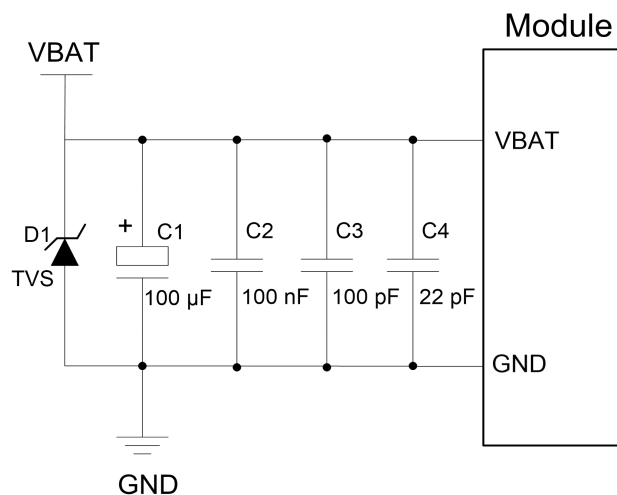

Figure 5: Reference Circuit for Power Supply

3.5.3. Power Supply Voltage Detection*

You can use **AT+CBC** to monitor and query the current VBAT voltage. The unit of the voltage value is millivolt. For detailed information about the command, see **document [2]**.

NOTE

“*” means under development.

3.6. Power-up/Power-down Scenarios

3.6.1. Power-up

After the module VBAT is powered on, keep the RESET_N and BOOT inputs not being pulled down, and the module can turn on automatically. The power-up timing is illustrated in the following figure.

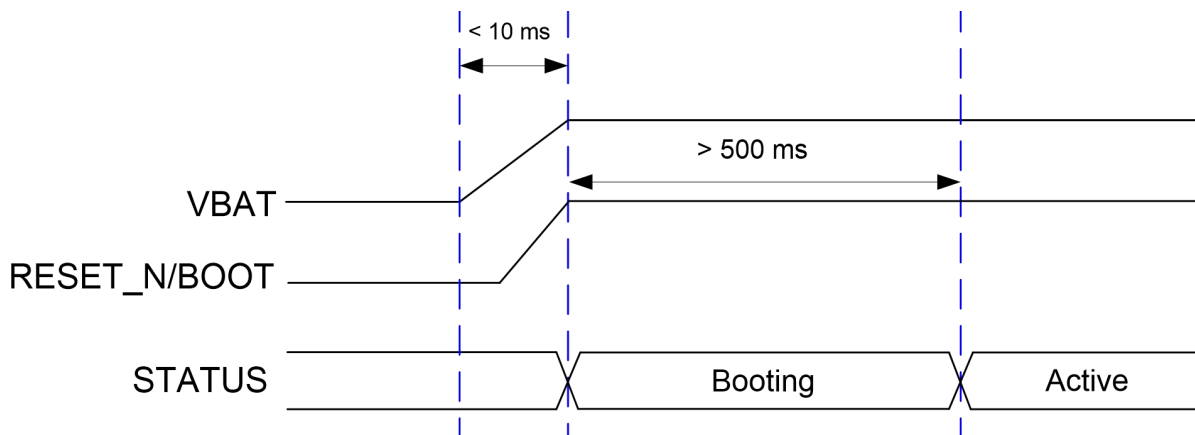

Figure 6: Power-up Timing

NOTES

1. After the VBAT is powered down, its voltage must be lower than 0.7 V. The specific discharge time needs to be evaluated based on the actual circuit test, and enough margin is left to avoid abnormal startup when the it is powered on again.
2. The power-up time of VBAT must be within 10 ms.
3. It is recommended that the MCU retain the RESET_N control pin. When the abnormal power-on sequence causes the module to start abnormally, the RESET_N control pin can control the module to reset to exit the abnormal state.
4. After VBAT is powered on, RESET_N and BOOT automatically rise to high level due to internal pull-ups.

3.6.2. Power-down

The module can be shut down through disconnecting VBAT power supply.

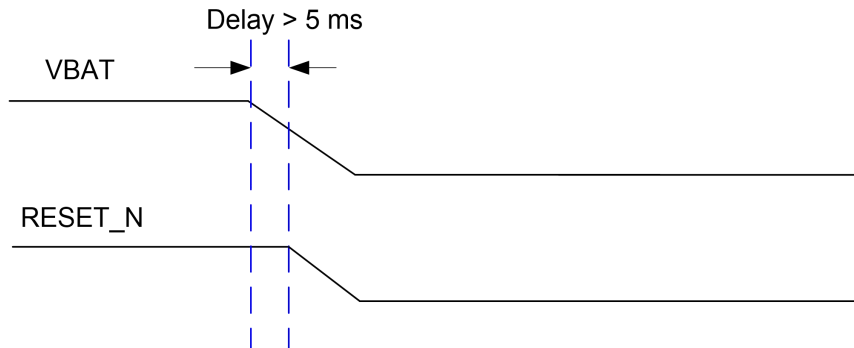

Figure 7: Power-down Timing

3.6.3. Reset

Driving RESET_N low for at least 50 ms will reset the module.

Table 9: Reset Pin Definition

Pin Name	Pin No.	Description	Reset Pull-down Time
RESET_N	15	Reset the module. Active low.	≥50 ms

The recommended circuits of resetting the module are shown below. An open drain/collector driver or button can be used to control the RESET_N pin.

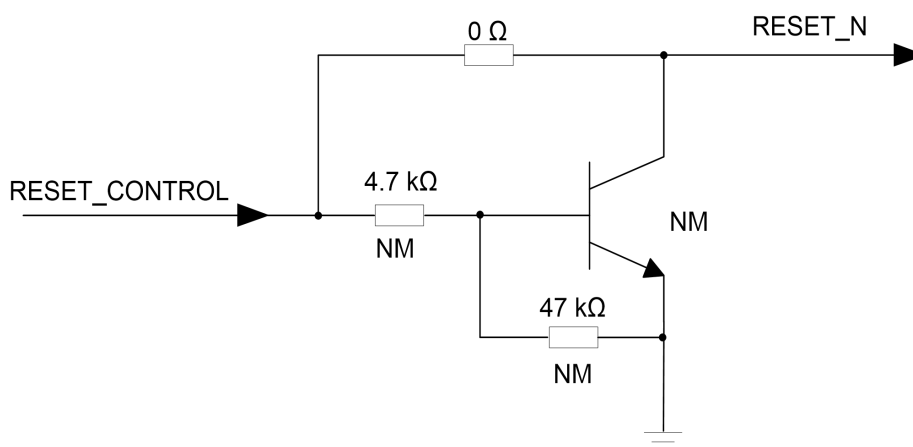

Figure 8: Reference Circuit of RESET_N by Using Driving Circuit

NOTES

1. When the high level output of RESET_CONTROL is more than 1.7 V and less than 3.6 V, and the low level output is less than 0.35 V, it is recommended to use the direct connection method to control the RESET_N pin of the module. In other cases, it must be controlled by an open collector drive circuit.
2. It is recommended to reserve a 100 nF capacitor position, which is not mounted by default.

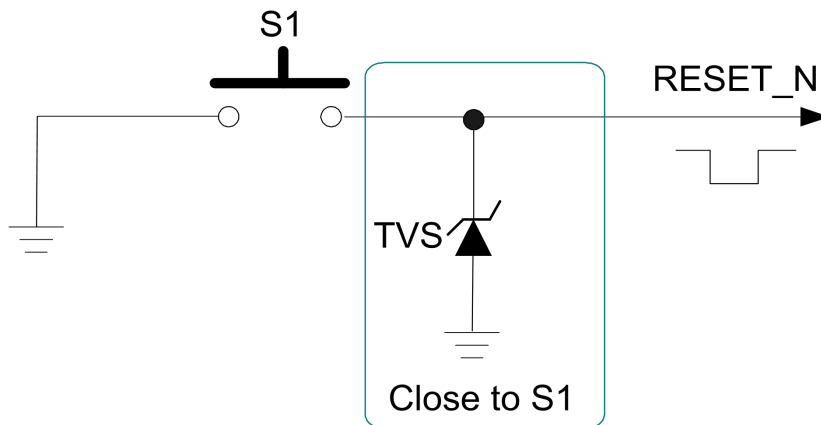

Figure 9: Reference Circuit of RESET_N by Using Button

3.6.4. Download

In the process of system reset or power-on, keep the BOOT pin input low and the module will enter the download mode.

In download mode, the firmware can be downloaded through the main serial port. After the download is complete, the module needs to be reset to exit the download mode.

An open drain/collector driver or button can be used to control the BOOT pin.

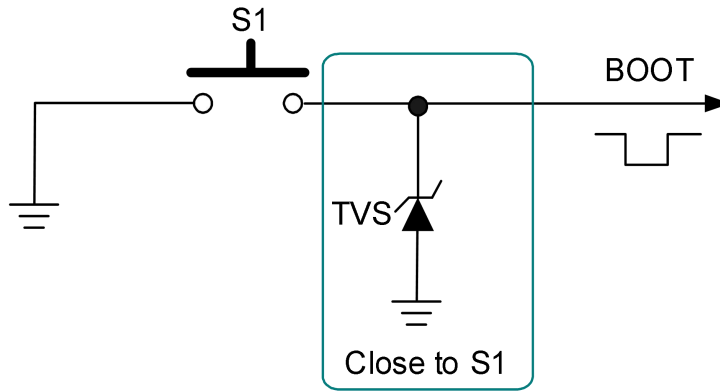

Figure 10: Reference Circuit of BOOT by Using Button

NOTE

If the BOOT pin is connected to a filter capacitor in parallel, the capacitance of the capacitor cannot be higher than 33 pF.

3.7. UART Interfaces

The module provides two UART ports: main UART port and debug UART port. The module is designed as DCE (Data Communication Equipment), following the traditional DCE-DTE (Data Terminal Equipment) connection.

Table 10: Pin Definition of UART Interfaces

Interface	Pin Name	Pin No.	Description
Main UART Port	MAIN_TXD	17	Main UART transmit
	MAIN_RXD	18	Main UART receive
Debug UART Port	DBG_RXD	38	Debug UART receive
	DBG_TXD	39	Debug UART transmit
Ring Indication	RI*	20	Ring indication (when there is a SMS or a URC output, the module will inform DTE with the RI pin)

3.7.1. Main UART Port

The main UART port supports AT command communication, data transmission and firmware upgrade.

- Default baud rate: 115200 bps
- Fixed baud rates: 2400 bps, 4800 bps, 9600 bps, 19200 bps, 38400 bps, 57600 bps, 115200 bps, 230400 bps, 460800 bps

When the port is used for firmware upgrade, the baud rate is 921600 bps by default.

When the module enters Deep Sleep/Light Sleep mode, it can wake up the module by sending AT commands through the main serial port. It is generally recommended to send the command **AT** continuously until **OK** is returned before sending AT commands to other services.

The figure below shows the connection between DCE and DTE.

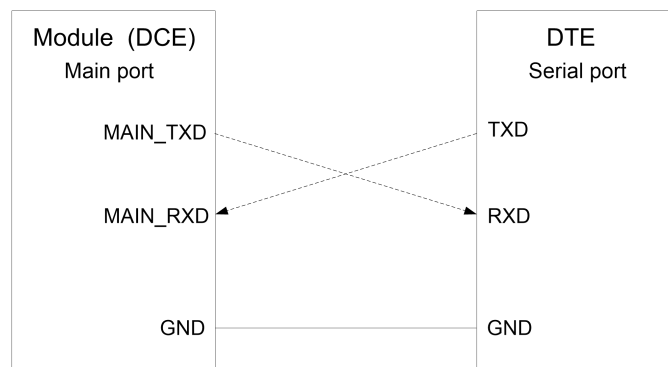

Figure 11: Reference Design for Main UART Port

3.7.2. Debug UART Port

Through debug tools, the debug UART port can be used to output logs for firmware debugging. Its baud rate is 6 Mbps by default. The following is a reference design of debug UART port.

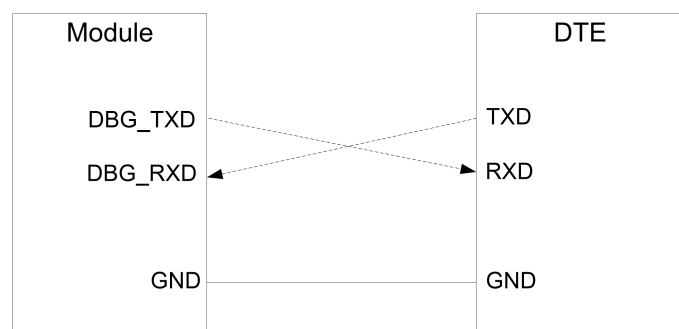

Figure 12: Reference Design of Debug UART Port

3.7.3. UART Application

The serial port voltage domain of this module is optional. Customers can select the appropriate voltage domain through VIO_SEL according to the actual situation. When VIO_SEL is floating, the VDD_EXT voltage domain is 1.8 V; when VIO_SEL is grounded, the VDD_EXT voltage domain is 3.3 V.

If the voltage domain of the customer application system is 1.8 V, VIO_SEL can be floating; If the voltage domain of the customer application system is 3.3 V, VIO_SEL can be grounded.

The following figure shows the reference circuit design:

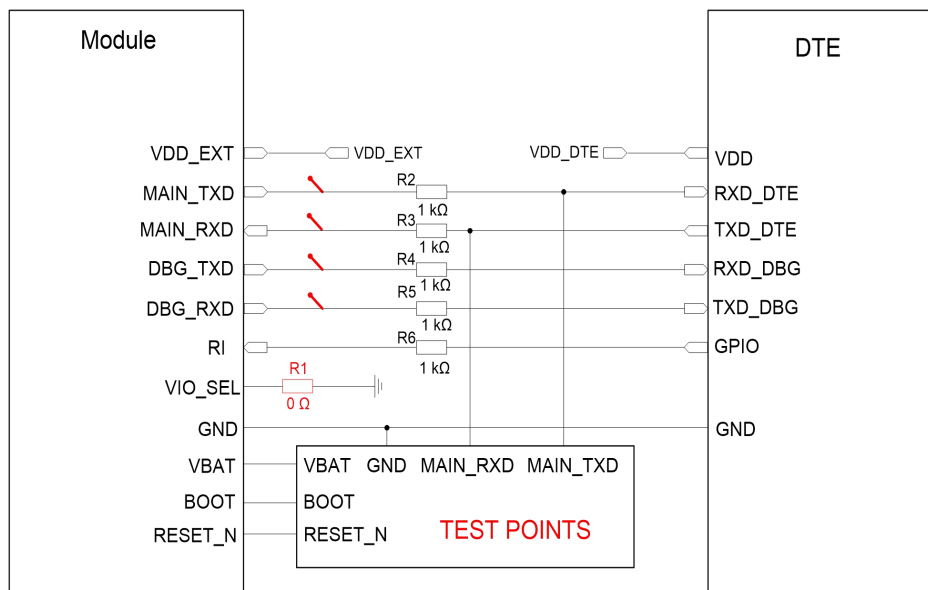

Figure 13: Reference Circuit Design of UART

The following circuit shows a reference design for the communication between the module and a PC with standard RS-232 interface. Make sure to select appropriate voltage domain through VIO_SEL according to the actual situation.

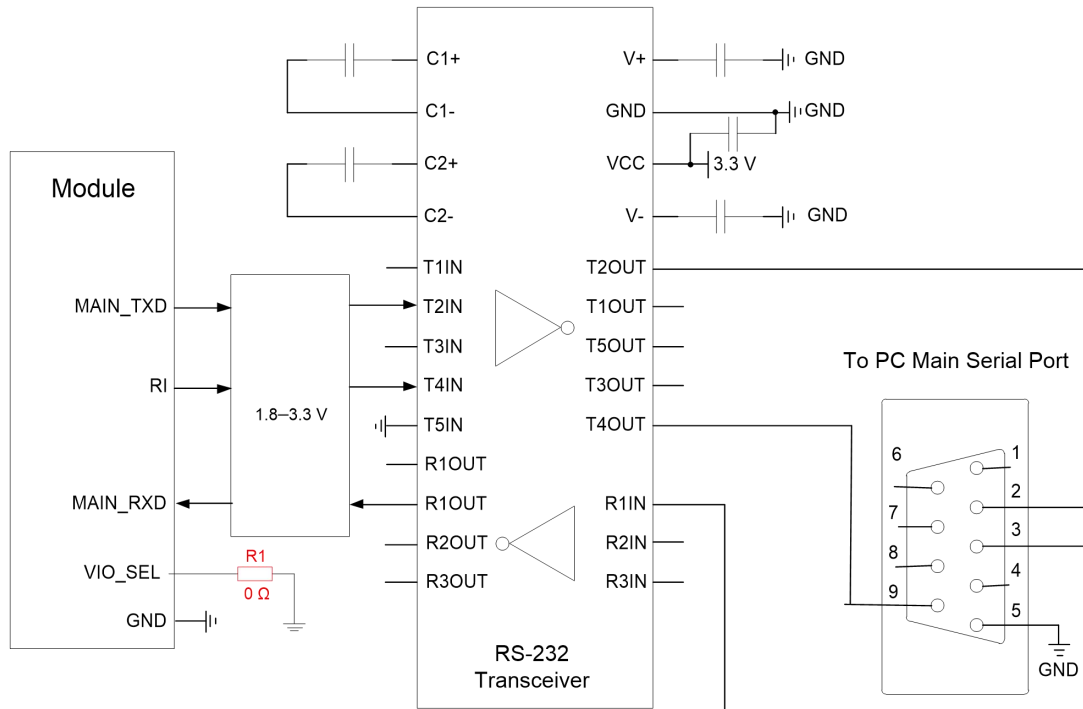



Figure 14: Sketch Map for RS-232 Interface Match

Please visit vendors' websites to select a suitable RS-232 transceiver, such as: <http://www.exar.com> and <http://www.maximintegrated.com>.

NOTES

1. If the voltage domain of your application system is 1.8 V, keep the R1 marked in red not mounted; If the voltage domain of your application system is 3.3 V, keep the R1 marked in red mounted.
2. “” represents the test points of UART interfaces. It is also recommended to reserve the test points of VBAT, BOOT and RESET_N, for convenient firmware upgrade and debugging when necessary.
3. VDD_EXT cannot pull up the module MAIN_RXD directly. If VDD_EXT need pull up the module MAIN_RXD, you need to connect a Schottky diode in series first, and then pull up the module MAIN_RXD through a 4.7-20 kΩ resistor. For more details, see **document [3]**.
4. When VIO_SEL is grounded and VBAT < 3.3 V, VDD_EXT = VBAT;
When VIO_SEL is grounded and VBAT ≥ 3.3 V, VDD_EXT = 3.3 V;
When VIO_SEL is floating, VDD_EXT = 1.8 V.

When the serial port voltage is neither 1.8 V nor 3.3 V, it is recommended to use a transistor level conversion circuit. The circuit design of dotted line section can refer to the design of solid line section, in terms of both module input and output circuit designs, but please pay attention to the direction of connection.

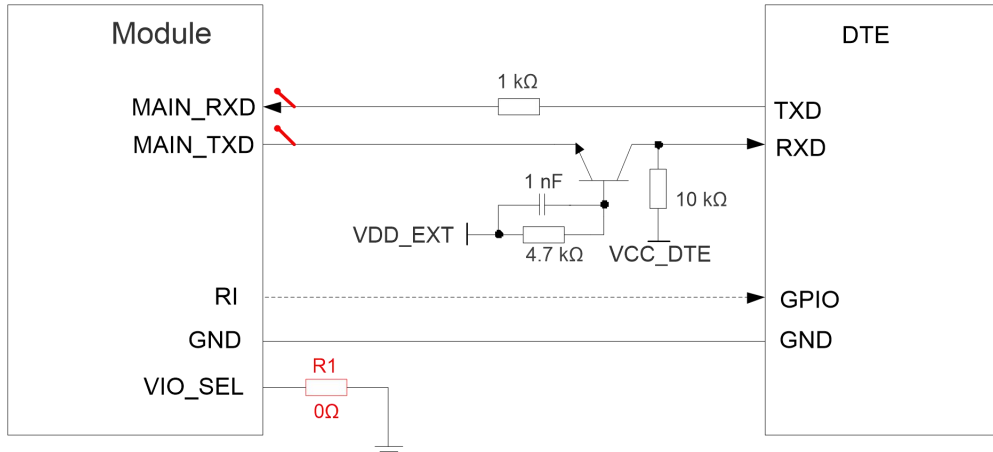

Figure 15: Reference Circuit with Transistor Circuit

NOTES

1. VDD_EXT cannot pull up MAIN_RXD directly. Due to the anti-backflow design of the MAIN_RXD pin, MAIN_RXD pin can be directly connected to the TXD of DTE in the 1.8–3.3 V voltage domain. If the Deep Sleep/Light Sleep mode wake-up function of the MAIN_RXD is enabled, it is recommended that MAIN_RXD does not use a level conversion circuit to avoid abnormal wake-up.
2. If you choose the transistor conversion circuit, don't mount the R1 marked in red.
3. If VDD_EXT need pull up the module MAIN_RXD, you need to connect a Schottky diode in series first, and then pull up the module MAIN_RXD through a 4.7-20 kΩ resistor. For more details, see **document [3]**.
4. Transistor circuit solution is not suitable for applications with high baud rates exceeding 460 kbps.

3.8. (U)SIM Interface

The (U)SIM card is powered by an internal regulator in the module. Both 1.8 V and 3.0 V (U)SIM cards are supported.

Table 11: Pin Definition of (U)SIM Interface

Pin Name	Pin No.	Description	Comment
(U)SIM_VDD	14	(U)SIM card power supply	When $3.0\text{ V} \leq V_{BAT} \leq 4.3\text{ V}$, support 1.8/3.0 V (U)SIM card; When $2.2\text{ V} \leq V_{BAT} < 3\text{ V}$, only support 1.8 V (U)SIM card; Maximum supply current: about 80 mA.

(U)SIM_CLK	13	(U)SIM card clock
(U)SIM_DATA	11	(U)SIM card data
(U)SIM_RST	12	(U)SIM card reset
(U)SIM_GND	10	Specified ground for (U)SIM card

A reference circuit design for (U)SIM interface with a 6-pin (U)SIM card connector is illustrated below.

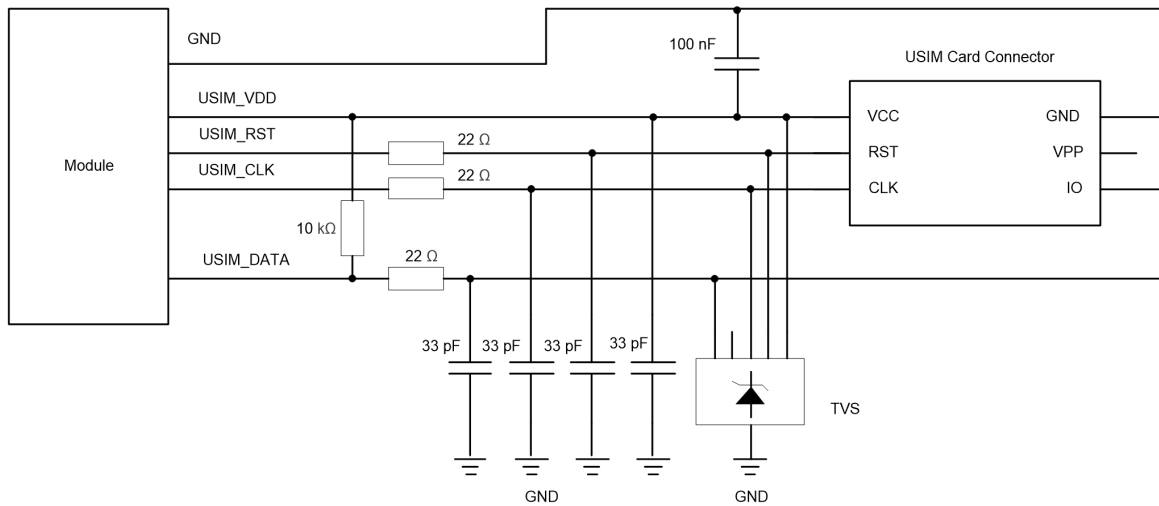

Figure 16: Reference Circuit for (U)SIM Interface with a 6-pin (U)SIM Card Connector

To enhance the reliability and availability of the (U)SIM card in applications, follow the criteria below in (U)SIM circuit design:

- Keep the placement of (U)SIM card connector as close to the module as possible. Keep the trace length as less than 200 mm as possible.
- Keep (U)SIM card signals away from RF and VBAT traces.
- Assure the trace between the ground of the module and that of (U)SIM card connector is short and wide. Keep the trace width of the ground no less than 0.5 mm to maintain the same electric potential. The decoupling capacitor between (U)SIM_VDD and GND should be not more than 1 μF and be placed close to the (U)SIM card connector.
- To avoid cross-talk between (U)SIM_DATA and (U)SIM_CLK, keep them away from each other and shield them separately with the surrounded ground.
- In order to offer good ESD protection, it is recommended to add a TVS diode array whose parasitic capacitance should be not more than 50 pF. The ESD protection device should be placed as close to (U)SIM card connector as possible, and ensure the (U)SIM card signal lines go through the ESD protection device first from (U)SIM card connector and then to the module. The 22 Ω resistors should be connected in series between the module and the (U)SIM card connector to suppress EMI spurious transmission and enhance ESD protection. Please note that the (U)SIM peripheral circuit should be

close to the (U)SIM card connector.

- The pull-up resistor on the SIM_DATA line can improve anti-jamming capability and should be placed close to the (U)SIM card connector.

NOTE

It is necessary (U)SIM_DATA must add a 10 kΩ pull-up resistor to (U)SIM_VDD to improve anti-interference ability.

3.9. ADC Interface*

The module provides a 12-bit ADC input channel to read the voltage value.

Table 12: Pin Definition of ADC Interface

Pin Name	Pin No.	Description	Sample Range
ADC0	9	Analog to digital converter interface	0–1.2 V

NOTES

1. 320 kΩ pull-down resistor is integrated inside the ADC pin. This resistor needs to be considered when calculating the resistor divider relationship.
2. “*” means under development.

3.10. RI Interface*

When there is a message received or a URC output, the module will notify DTE through the RI interface.

Table 13: RI Signal Status

Module Status	RI Signal Level
Standby	High pulse
URC	When a URC is received, RI outputs 120 ms low pulse and starts data output.

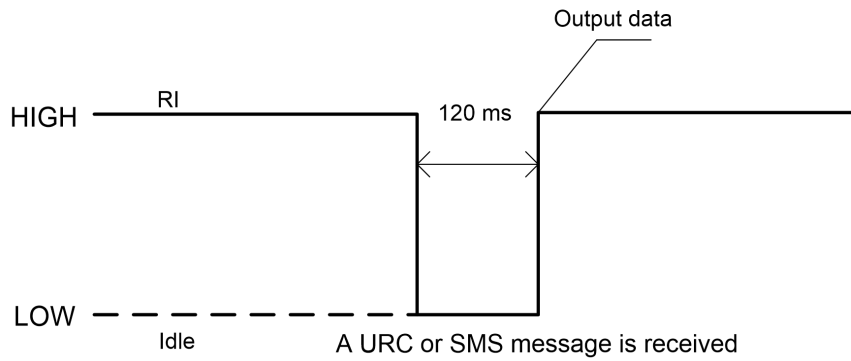

Figure 17: RI Behaviour When a URC is Received

NOTE

“*” means under development.

3.11. NETLIGHT Interface*

NETLIGHT can be used to indicate the network status of the module. The following table illustrates the module status indicated by NETLIGHT.

A reference circuit is shown as below.

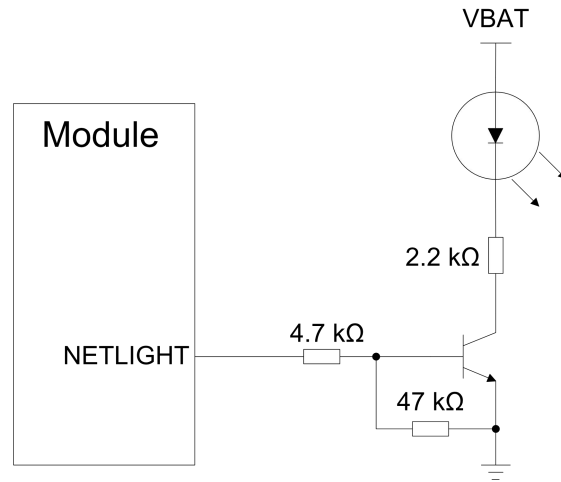

Figure 18: Reference Design of NETLIGHT

NOTE

“*” means under development.

4 Antenna Interface

The pin 35 is the RF antenna pad. The antenna port has an impedance of 50 Ω .

4.1. Pin Definition

Table 14: Pin Definition of NB-IoT Antenna Interface

Pin Name	Pin No.	Description
ANT_RF	35	RF antenna interface
GND	34, 36, 37	Ground

4.2. Operating Frequencies

Table 15: Module Operating Frequencies

Frequency Band	Receiving Frequency	Transmitting Frequency
B1	2110–2170 MHz	1920–1980 MHz
B2	1930–1990 MHz	1850–1910 MHz
B3	1805–1880 MHz	1710–1785 MHz
B4	2110–2155 MHz	1710–1755 MHz
B5	869–894 MHz	824–849 MHz
B8	925–960 MHz	880–915 MHz
B12	729–746 MHz	699–716 MHz
B13	746–756 MHz	777–787 MHz

B17	734–746 MHz	704–716 MHz
B18	860–875 MHz	815–830 MHz
B19	875–890 MHz	830–845 MHz
B20	791–821 MHz	832–862 MHz
B25	1930–1995 MHz	1850–1915 MHz
B28	758–803 MHz	703–748 MHz
B66	2110–2180 MHz	1710–1780 MHz
B70	1995–2020 MHz	1695–1710 MHz
B85	728–746 MHz	698–716 MHz

4.3. RF Antenna Reference Design

BC660K-GL provides an RF antenna pin for external NB-IoT antenna connection.

- The RF trace on host PCB connected to the module's RF antenna pad should be coplanar waveguide or microstrip, whose characteristic impedance should be close to 50 Ω .
- The module comes with ground pads which are next to the antenna pad to give a better grounding.
- In order to achieve better RF performance, it is recommended to reserve a π type matching circuit and place the π -type matching components (R1/C1/C2) as close to the antenna as possible. By default, the capacitors (C1/C2) are not mounted and a 0 Ω resistor is mounted on R1.

A reference design of the RF interface is shown as below.

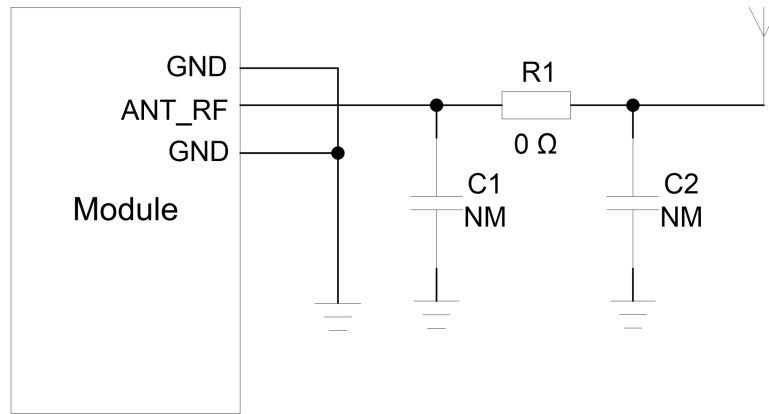

Figure 19: Reference Design of NB-IoT Antenna Interface

4.4. Reference Design of RF Layout

For users' PCB, the characteristic impedance of all RF traces should be controlled to 50 Ω. The impedance of the RF traces is usually determined by the trace width (W), the materials' dielectric constant, height from the reference ground to the signal layer (H), and the clearance between RF traces and grounds (S). Microstrip or coplanar waveguide is typically used in RF layout to control characteristic impedance. The following are reference designs of microstrip or coplanar waveguide with different PCB structures.

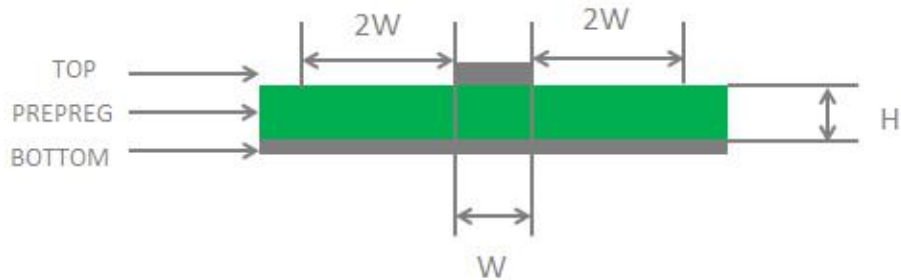

Figure 20: Microstrip Design on a 2-layer PCB

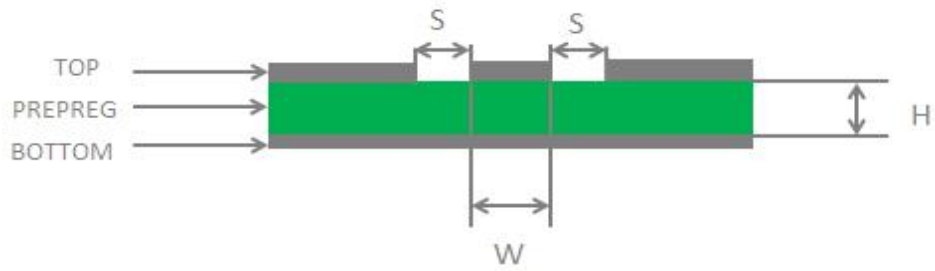

Figure 21: Coplanar Waveguide Design on a 2-layer PCB

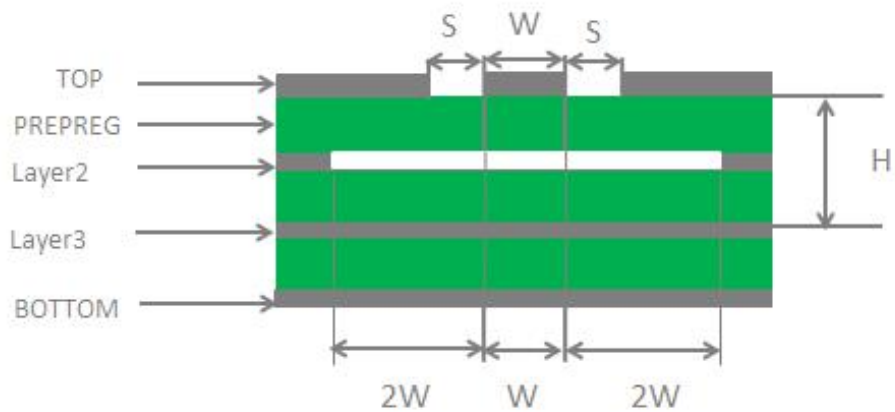

Figure 22: Coplanar Waveguide Design on a 4-layer PCB (Layer 3 as Reference Ground)

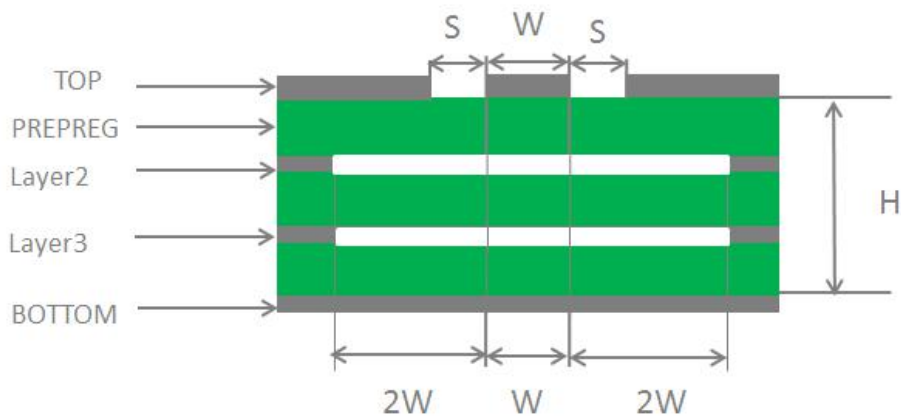

Figure 23: Coplanar Waveguide Design on a 4-layer PCB (Layer 4 as Reference Ground)

To ensure RF performance and reliability, the following principles should be complied with in RF layout design:

- Use an impedance simulation tool to accurately control the characteristic impedance of RF traces to 50 Ω .
- The GND pins adjacent to RF pins should not be designed as thermal relief pads, and should be fully connected to ground.
- The distance between the RF pins and the RF connector should be as short as possible, and all the right-angle traces should be changed to curved ones.
- There should be clearance under the signal pin of the antenna connector or solder joint.
- The reference ground of RF traces should be complete. Meanwhile, adding some ground vias around RF traces and the reference ground could help to improve RF performance. The distance between the ground vias and RF traces should be no less than two times as wide as RF signal traces ($2 \times W$).

For more details, see **document [4]**.

4.5. Antenna Requirements

To minimize the loss on RF trace and RF cable, pay attention to the antenna design. The following tables show the requirements on NB-IoT antenna.

Table 16: Antenna Cable Insertion Loss Requirements

Band	Requirements
LTE B5/B8/B12/B13/B17/B18/B19/B20/B28/B85	Cable insertion loss: < 1 dB
LTE B1/B2/B3/B4/B25/B66/B70	Cable insertion loss: < 1.5 dB

Table 17: Required Antenna Parameters

Parameters	Requirements
Frequency Range	698–2200 MHz
VSWR	≤ 2
Efficiency	> 30 %
Max Input Power (W)	50
Input Impedance (Ω)	50

4.6. RF Output Power

Table 18: RF Conducted Output Power

Frequency Band	Max.	Min.
B1	23 dBm \pm 2 dB	< -39 dBm
B2	23 dBm \pm 2 dB	< -39 dBm
B3	23 dBm \pm 2 dB	< -39 dBm
B4	23 dBm \pm 2 dB	< -39 dBm
B5	23 dBm \pm 2 dB	< -39 dBm
B8	23 dBm \pm 2 dB	< -39 dBm
B12	23 dBm \pm 2 dB	< -39 dBm
B13	23 dBm \pm 2 dB	< -39 dBm
B17	23 dBm \pm 2 dB	< -39 dBm
B18	23 dBm \pm 2 dB	< -39 dBm
B19	23 dBm \pm 2 dB	< -39 dBm
B20	23 dBm \pm 2 dB	< -39 dBm
B25	23 dBm \pm 2 dB	< -39 dBm
B28	23 dBm \pm 2 dB	< -39 dBm
B66	23 dBm \pm 2 dB	< -39 dBm
B70	23 dBm \pm 2 dB	< -39 dBm
B85	23 dBm \pm 2 dB	< -39 dBm

NOTE

The design conforms to the NB-IoT radio protocols in *3GPP Rel.13*.

4.7. RF Receiving Sensitivity

Table 19: Receiving Sensitivity (with RF Retransmissions)

Frequency Band	Receiving Sensitivity
B1	≤ -129 dBm
B2	≤ -129 dBm
B3	≤ -129 dBm
B4	≤ -129 dBm
B5	≤ -129 dBm
B8	≤ -129 dBm
B12	≤ -129 dBm
B13	≤ -129 dBm
B17	≤ -129 dBm
B18	≤ -129 dBm
B19	≤ -129 dBm
B20	≤ -129 dBm
B25	≤ -129 dBm
B28	≤ -129 dBm
B66	≤ -129 dBm
B70	≤ -129 dBm
B85	≤ -129 dBm

4.8. Recommended RF Connector for Antenna Installation

If RF connector is used for antenna connection, it is recommended to use the U.FL-R-SMT connector provided by *HIROSE*.

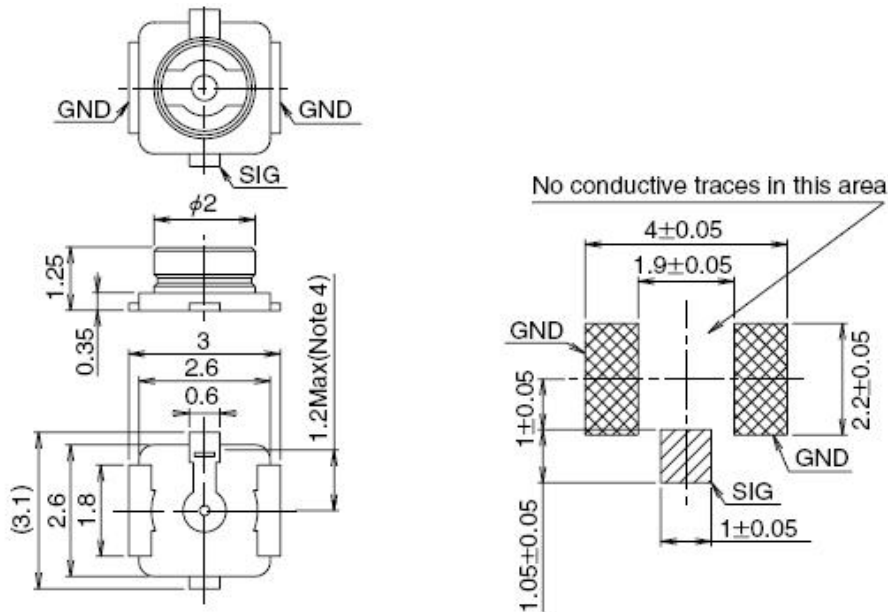

Figure 24: Dimensions of the U.FL-R-SMT Connector (Unit: mm)

U.FL-LP serial connectors listed in the following figure can be used to match the U.FL-R-SMT.

	U.FL-LP-040	U.FL-LP-066	U.FL-LP(V)-040	U.FL-LP-062	U.FL-LP-088
Part No.					
Mated Height	2.5mm Max. (2.4mm Nom.)	2.5mm Max. (2.4mm Nom.)	2.0mm Max. (1.9mm Nom.)	2.4mm Max. (2.3mm Nom.)	2.4mm Max. (2.3mm Nom.)
Applicable cable	Dia. 0.81mm Coaxial cable	Dia. 1.13mm and Dia. 1.32mm Coaxial cable	Dia. 0.81mm Coaxial cable	Dia. 1mm Coaxial cable	Dia. 1.37mm Coaxial cable
Weight (mg)	53.7	59.1	34.8	45.5	71.7
RoHS	YES				

Figure 25: Mechanicals of U.FL-LP Connectors

The following figure describes the space factor of mated connector.

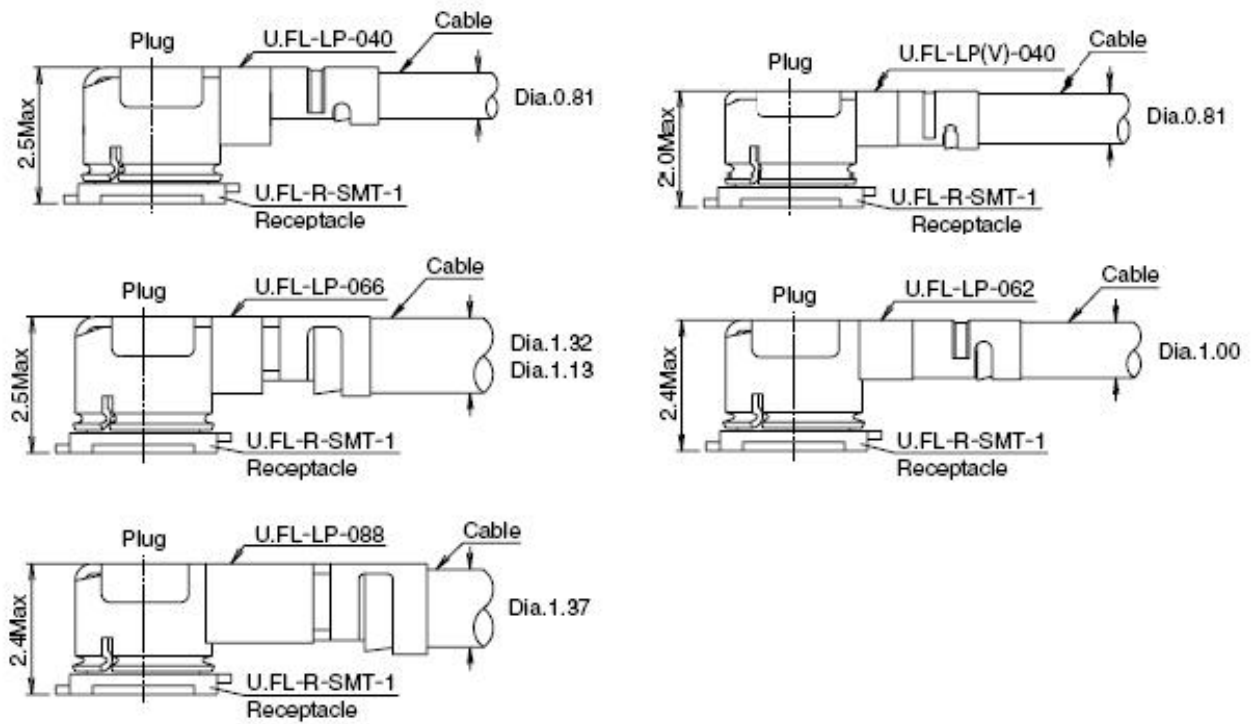

Figure 26: Space Factor of Mated Connector (Unit: mm)

For more details, please visit <http://www.hirose.com>.

5 Reliability and Electrical Characteristics

5.1. Operating and Storage Temperatures

The following table lists the operating and storage temperatures of the module.

Table 20: Operation and Storage Temperatures

Parameter	Min.	Typ.	Max.	Unit
Operating Temperature Range ¹⁾	-35	+25	+75	°C
Extended Temperature Range ²⁾	-40		+85	°C
Storage Temperature Range	-40		+90	°C

NOTES

- ¹⁾ Within operating temperature range, the module is 3GPP compliant.
- ²⁾ Within extended temperature range, the module remains the ability to establish and maintain functions such as SMS* and data transmission, without any unrecoverable malfunction. Radio spectrum and radio network will not be influenced, while one or more specifications, such as P_{out}, may exceed the specified tolerances of 3GPP. When the temperature returns to the normal operation temperature levels, the module will meet 3GPP specifications again.
- “*” means under development.

5.2. Current Consumption

The table below lists the current consumption of BC660K-GL under different states.

Table 21: Module Current Consumption (3.3 V VBAT Power Supply)

Deep Sleep									
AP Mode	Modem Mode	Min.	Typ.	Max.	Unit				
Idle	PSM	/	0.8	/	μA				
Light Sleep									
AP Mode	Modem Mode	Min.	Typ.	Max.	Unit				
	eDRX = 40.96 s, PTW = 10.24 s, ECL = 0	/	38	/	μA				
Idle	@ DRX = 1.28 s	/	220	/	μA				
	@ DRX = 2.56 s	/	110	/	μA				
Active ¹⁾									
AP Mode	Modem Mode	Min.	Typ.	Max. ²⁾	Unit				
					B1 @ 23dBm	/	111	300	mA
					B2 @ 23 dBm	/	108	305	mA
					B3 @ 23 dBm	/	100	280	mA
					B4 @ 23 dBm	/	100	277	mA
					B5 @ 23 dBm	/	98	270	mA
Normal	Single-tone (15 kHz subcarrier spacing)				B8 @ 23 dBm	/	105	299	mA
					B12 @ 23 dBm	/	120	332	mA
					B13 @ 23 dBm	/	100	283	mA
					B17 @ 23 dBm	/	115	325	mA
					B18 @ 23 dBm	/	94	265	mA

	B19 @ 23 dBm	/	95	270	mA
	B20 @ 23 dBm	/	98	272	mA
	B25 @ 23 dBm	/	108	301	mA
	B28 @ 23 dBm	/	109	310	mA
	B66 @ 23 dBm	/	101	280	mA
	B70 @ 23 dBm	/	104	276	mA
	B85 @ 23 dBm	/	115	329	mA
	B1 @ 23 dBm	/	240	311	mA
	B2 @ 23 dBm	/	230	296	mA
	B3 @ 23 dBm	/	213	274	mA
	B4 @ 23 dBm	/	212	273	mA
	B5 @ 23 dBm	/	202	263	mA
	B8 @ 23 dBm	/	221	298	mA
	B12 @ 23 dBm	/	259	328	mA
	B13 @ 23 dBm	/	218	279	mA
Single-tone (3.75 kHz subcarrier spacing)	B17 @ 23 dBm	/	252	325	mA
	B18 @ 23 dBm	/	199	258	mA
	B19 @ 23 dBm	/	201	260	mA
	B20 @ 23 dBm	/	207	267	mA
	B25 @ 23 dBm	/	232	297	mA
	B28 @ 23 dBm	/	240	306	mA
	B66 @ 23 dBm	/	213	274	mA
	B70 @ 23 dBm	/	216	273	mA
	B85 @ 23 dBm	/	252	323	mA

NOTES

1. ¹⁾Power consumption under instrument test condition.
2. ²⁾The “maximum value” in “Active” mode refers to the maximum pulse current during RF emission.

5.3. Electrostatic Discharge

The module is not protected against electrostatics discharge (ESD) in general. Consequently, it is subject to ESD handling precautions that typically apply to ESD sensitive components. Proper ESD handling and packaging procedures must be applied throughout the processing, handling and operation of any application that incorporates the module.

The following table shows the module’s electrostatic discharge characteristics.

Table 22: Electrostatic Discharge Characteristics (25 °C, 45 % Relative Humidity)

Tested Interfaces	Contact Discharge	Air Discharge	Unit
VBAT, GND	±5	±10	kV
Antenna interface	±5	±10	kV
Other interfaces	±0.5	±1	kV

6 Mechanical Features

This chapter describes the mechanical dimensions of the module. All dimensions are measured in millimeter (mm), and the dimensional tolerances are ± 0.05 mm unless otherwise specified.

6.1. Mechanical Dimensions

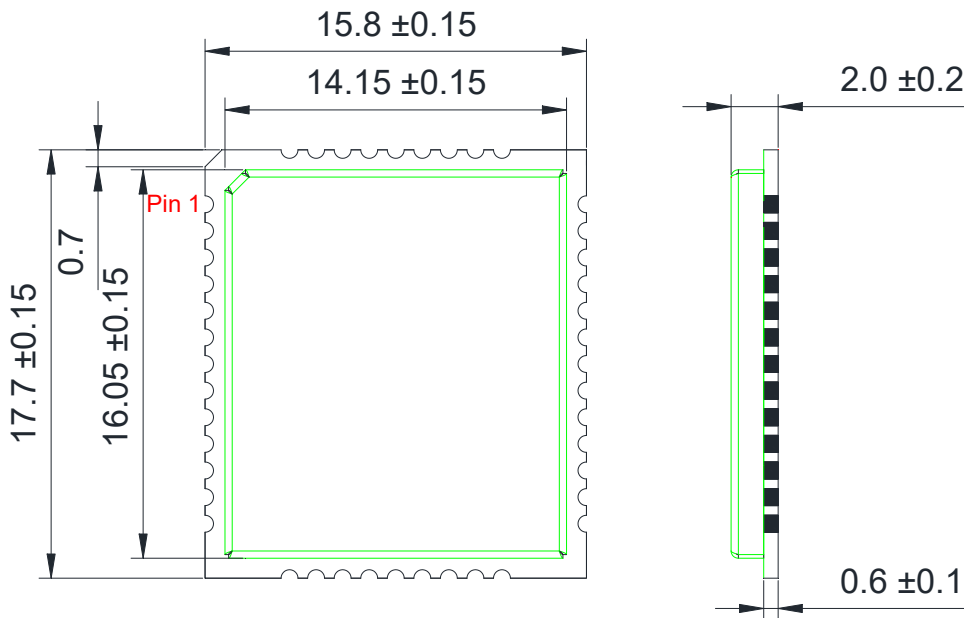

Figure 27: BC660K-GL Top and Side Dimensions (Unit: mm)

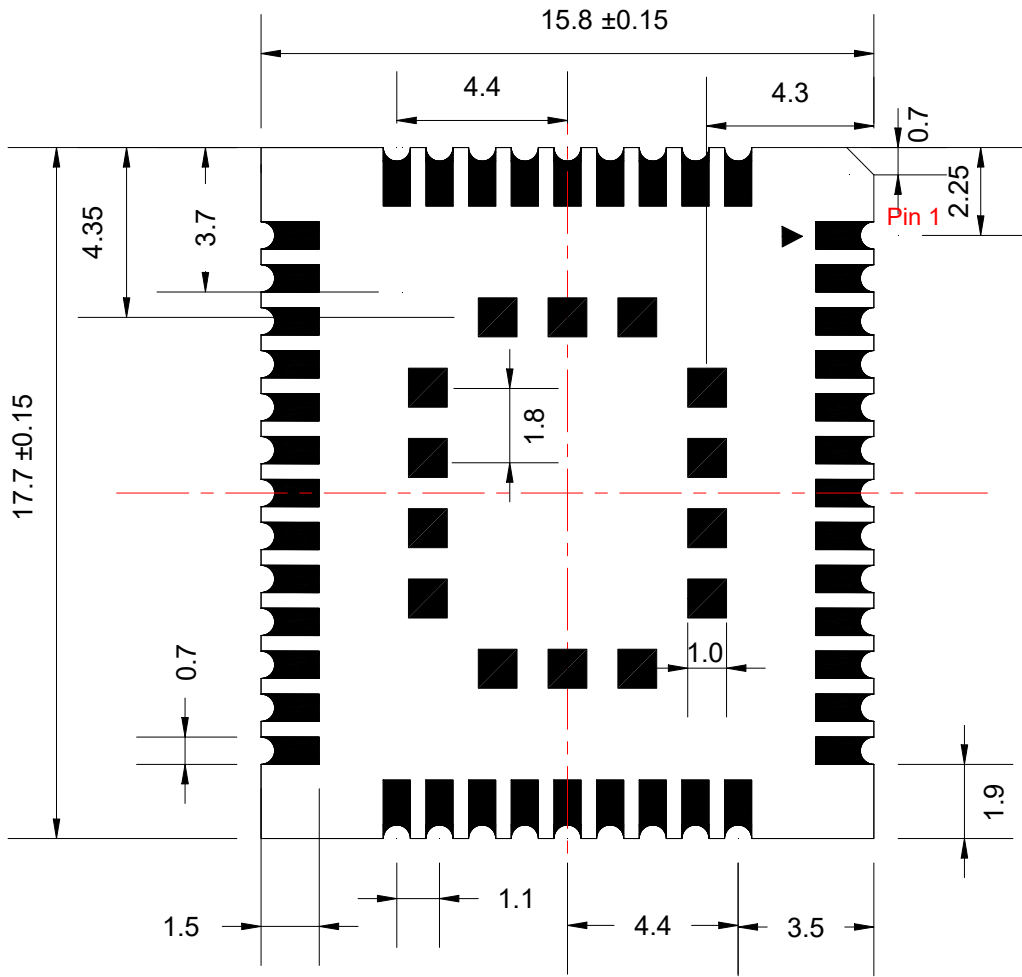

Figure 28: Module Bottom Dimension (Bottom View)

NOTE

The package warpage level of the module conforms to JEITA ED-7306 standard.

6.2. Recommended Footprint

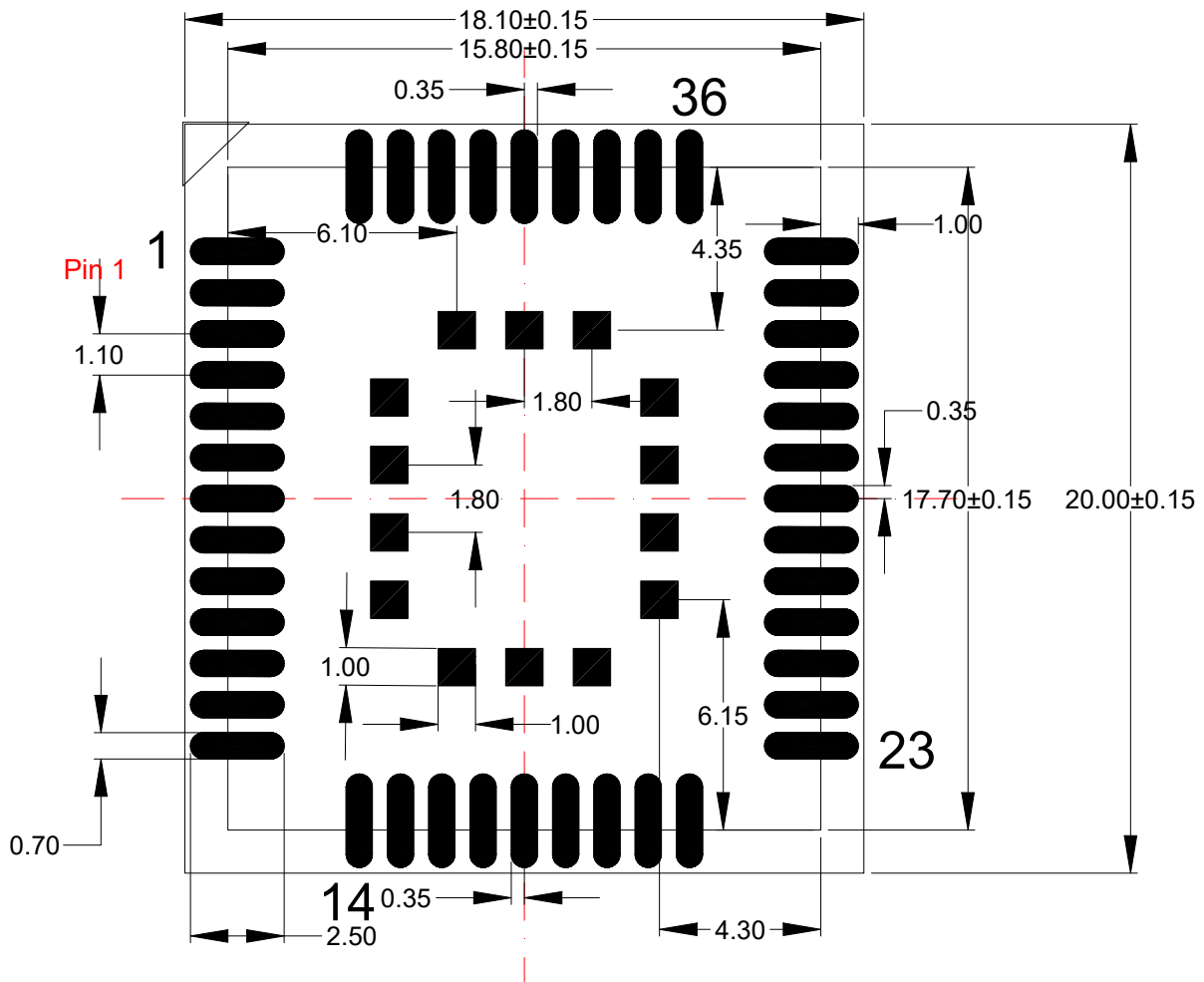

Figure 29: Recommended Footprint (Unit: mm)

NOTE

For easy maintenance of the module, it is recommended to keep about 3 mm between the module and other components on the motherboard.

6.3. Top and Bottom Views



Figure 30: Top View of the Module

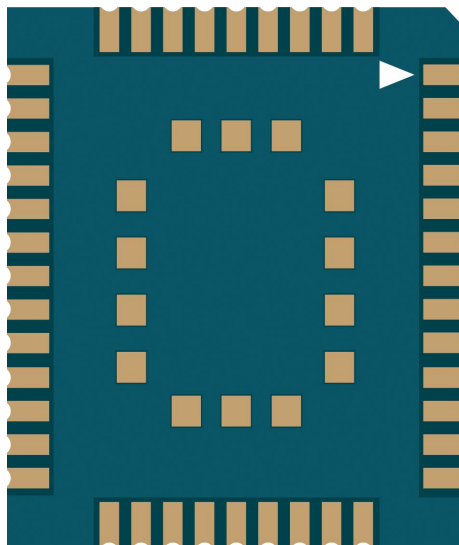

Figure 31: Bottom View of the Module

NOTE

Images above are for illustration purpose only and may differ from the actual module. For authentic appearance and label, please refer to the module received from Quectel.

7 Storage, Manufacturing and Packaging

7.1. Storage

The module is provided with vacuum-sealed packaging. MSL of the module is rated as 3. The storage requirements are shown below.

1. Recommended Storage Condition: The temperature should be 23 ± 5 °C and the relative humidity should be 35–60 %.
2. The storage life (in vacuum-sealed packaging) is 12 months in Recommended Storage Condition.
3. The floor life of the module is 168 hours ¹⁾ in a plant where the temperature is 23 ± 5 °C and relative humidity is below 60 %. After the vacuum-sealed packaging is removed, the module must be processed in reflow soldering or other high-temperature operations within 168 hours. Otherwise, the module should be stored in an environment where the relative humidity is less than 10 % (e.g. a drying cabinet).
4. The module should be pre-baked to avoid blistering, cracks and inner-layer separation in PCB under the following circumstances:
 - The module is not stored in Recommended Storage Condition;
 - Violation of the third requirement above occurs;
 - Vacuum-sealed packaging is broken, or the packaging has been removed for over 24 hours;
 - Before module repairing.
5. If needed, the pre-baking should follow the requirements below:
 - The module should be baked for 8 hours at 120 ± 5 °C;
 - All modules must be soldered to PCB within 24 hours after the baking, otherwise they should be put in a dry environment such as in a drying oven.

NOTES

1. ¹⁾ This floor life is only applicable when the environment conforms to *IPC/JEDEC J-STD-033*.
2. To avoid blistering, layer separation and other soldering issues, it is forbidden to expose the modules to the air for a long time. If the temperature and moisture do not conform to *IPC/JEDEC J-STD-033* or the relative moisture is over 60%, It is recommended to start the solder reflow process within 24 hours after the package is removed. And do not remove the packages of tremendous modules if they are not ready for soldering.
3. Please take the module out of the packaging and put it on high-temperature resistant fixtures before the baking. If shorter baking time is desired, please refer to *IPC/JEDEC J-STD-033* for baking procedure.

7.2. Manufacturing and Soldering

Push the squeegee to apply the solder paste on the surface of stencil, thus making the paste fill the stencil openings and then penetrate to the PCB. The force on the squeegee should be adjusted properly so as to produce a clean stencil surface on a single pass. To ensure the module soldering quality, the thickness of stencil for the module is recommended to be 0.15–0.18 mm. For more details, see **document [5]**.

It is suggested that the peak reflow temperature is 238–245 °C, and the absolute maximum reflow temperature is 245 °C. To avoid damage to the module caused by repeated heating, it is strongly recommended that the module should be mounted after reflow soldering for the other side of PCB has been completed. The recommended reflow soldering thermal profile (lead-free reflow soldering) and related parameters are shown below.

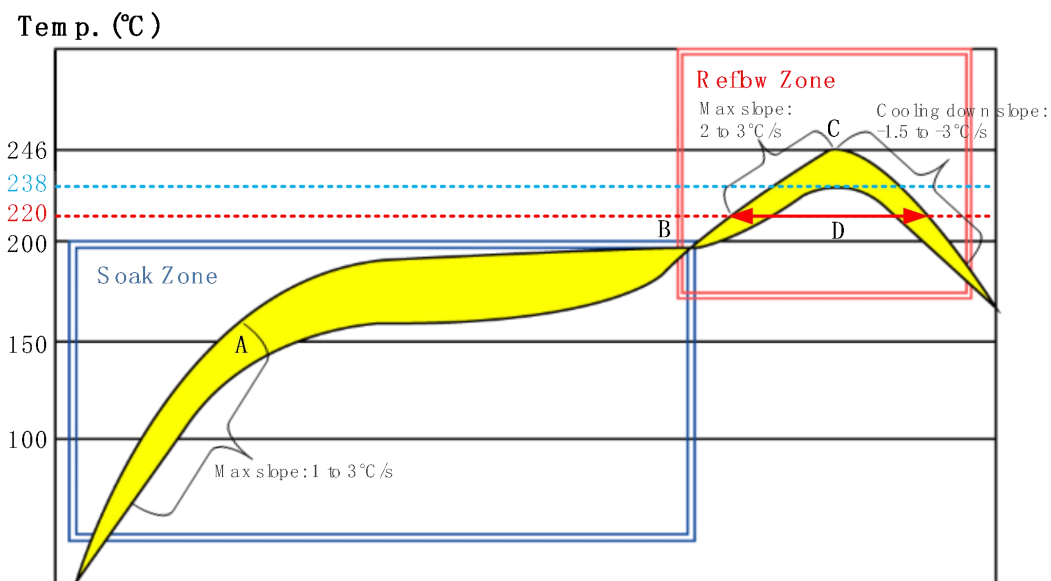

Figure 32: Recommended Reflow Soldering Thermal Profile

Table 23: Recommended Thermal Profile Parameters

Factor	Recommendation
Soak Zone	
Max slope	1–3 °C/s
Soak time (between A and B: 150°C and 200°C)	70–120 s
Reflow Zone	
Max slope	2–3 °C/s
Reflow time (D: over 220°C)	45–70 s
Max temperature	238 to 246 °C
Cooling down slope	-1.5 to -3 °C/s
Reflow Cycle	
Max reflow cycle	1

NOTES

1. During manufacturing and soldering, or any other processes that may contact the module directly, NEVER wipe the module's shielding can with organic solvents, such as acetone, ethyl alcohol, isopropyl alcohol, trichloroethylene, etc. Otherwise, the shielding can may become rusted.
2. The shielding can for the module is made of Cupro-Nickel base material. It is tested that after 12 hours' Neutral Salt Spray test, the laser engraved label information on the shielding can is still clearly identifiable and the QR code is still readable, although white rust may be found.
3. If a conformal coating is necessary for the module, do NOT use any coating material that may chemically react with the PCB or shielding cover, and prevent the coating material from flowing into the module.

7.3. Tape and Reel Packaging

The modules are stored in a vacuum-sealed bag which is ESD-proof. The bag should not be opened until the devices are ready to be soldered onto the application.

The reel is 330 mm in diameter and each reel contains 250 modules.

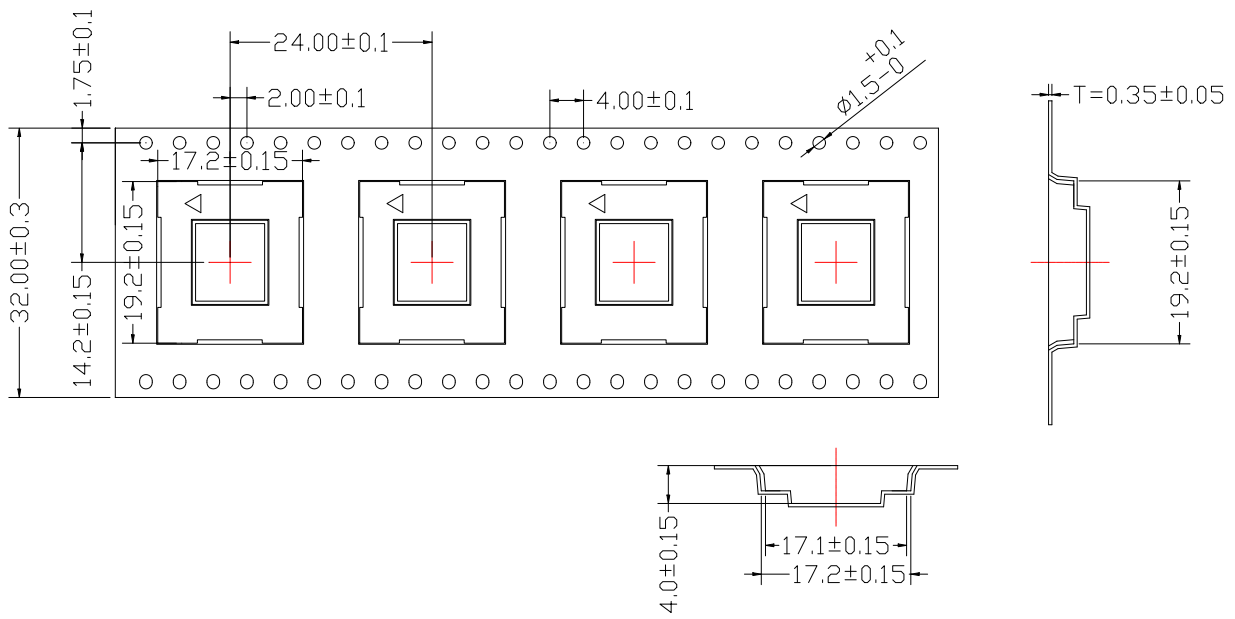

Figure 33: Tape Dimensions (Unit: mm)

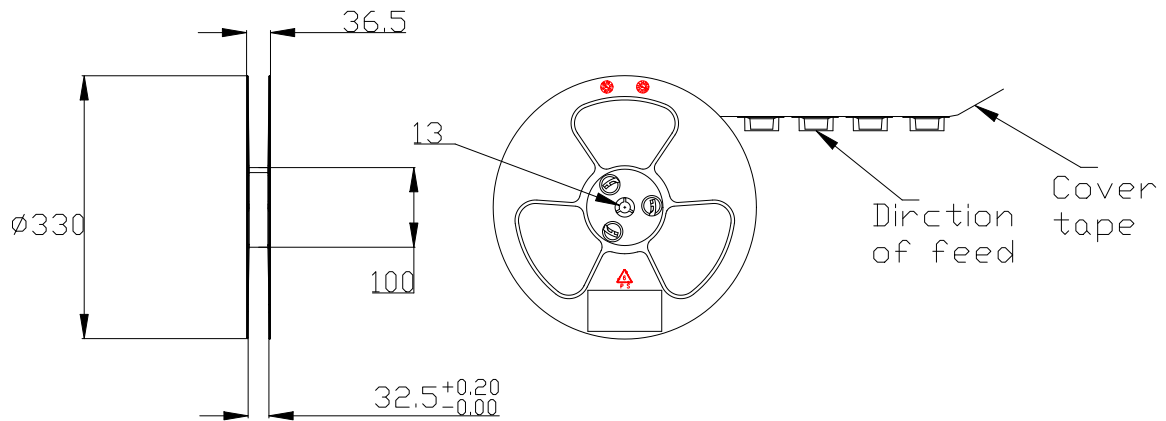

Figure 34: Reel Dimensions (Unit: mm)

8 Appendix A References

Table 24: Related Documents

SN	Document Name	Description
[1]	Quectel_BC660K-GL-TE-B_User_Guide	BC660K-GL-TE-B User Guide
[2]	Quectel_BC660K-GL_AT_Commands_Manual	BC660K-GL AT Commands Manual
[3]	Quectel_BC660K-GL_Reference_Design	BC660K-GL Reference Design
[4]	Quectel_RF_Layout_Application_Note	RF Layout Application Note
[5]	Quectel_Module_Secondary_SMT_User_Guide	Module Secondary SMT User Guide

Table 25: Terms and Abbreviations

Abbreviation	Description
ADC	Analog-to-Digital Converter
DCE	Data Communications Equipment (typically module)
DRX	Discontinuous Reception
DTE	Data Terminal Equipment (typically computer, external controller)
DTLS	Datagram Transport Layer Security
eDRX	extended Discontinuous Reception
EMI	Electromagnetic Interference
ESD	Electrostatic Discharge
H-FDD	Half Frequency Division Duplexing
HTTP	Hyper Text Transfer Protocol
HTTPS	Hyper Text Transfer Protocol over Secure Socket Layer

I/O	Input/Output
kbps	Kilo Bits Per Second
LED	Light Emitting Diode
LTE	Long Term Evolution
LwM2M	Lightweight M2M
MQTT	Message Queuing Telemetry Transport
NB-IoT	Narrow Band- Internet of Things
PCB	Printed Circuit Board
PDU	Protocol Data Unit
PSM	Power Save Mode
PTW	Paging Time Window
RF	Radio Frequency
RTC	Real Time Clock
RXD	Receive Data
SMS	Short Message Service
TCP	Transmission Control Protocol
TE	Terminal Equipment
TLS	Transport Layer Security
TXD	Transmitting Data
UART	Universal Asynchronous Receiver & Transmitter
UDP	User Datagram Protocol
URC	Unsolicited Result Code
(U)SIM	Universal Subscriber Identification Module
VSWR	Voltage Standing Wave Ratio
Vmax	Maximum Voltage Value

V _{norm}	Normal Voltage Value
V _{min}	Minimum Voltage Value
V _{IHmax}	Maximum Input High Level Voltage Value
V _{IHmin}	Minimum Input High Level Voltage Value
V _{ILmax}	Maximum Input Low Level Voltage Value
V _{ILmin}	Minimum Input Low Level Voltage Value
V _{Imax}	Absolute Maximum Input Voltage Value
V _{Inorm}	Absolute Normal Input Voltage Value
V _{Imin}	Absolute Minimum Input Voltage Value
V _{OHmax}	Maximum Output High Level Voltage Value
V _{OHmin}	Minimum Output High Level Voltage Value
V _{OLmax}	Maximum Output Low Level Voltage Value
V _{OLmin}	Minimum Output Low Level Voltage Value

Installation engineers need to be aware of the potential risk of the thermal effects of radio frequency energy and how to stay protected against undue risk.

The EUT is a mobile device; maintain at least a 20 cm separation between the EUT and the user's body and must not transmit simultaneously with any other antenna or transmitter.

OEM/Integrators Installation Manual

Important Notice to OEM integrators 1. This module is limited to OEM installation ONLY. 2. This module is limited to installation in mobile or fixed applications, according to Part 2.1091(b). 3. The separate approval is required for all other operating configurations, including portable configurations with respect to Part 2.1093 and different antenna configurations 4. For FCC Part 15.31 (h) and (k): The host manufacturer is responsible for additional testing to verify compliance as a composite system. When testing the host device for compliance with Part 15 Subpart B, the host manufacturer is required to show compliance with Part 15 Subpart B while the transmitter module(s) are installed and operating. The modules should be transmitting and the evaluation should confirm that the module's intentional emissions are compliant (i.e. fundamental and out of band emissions). The host manufacturer must verify that there are no additional unintentional emissions other than what is permitted in Part 15 Subpart B or emissions are complaint with the transmitter(s) rule(s). The Grantee will provide guidance to the host manufacturer for Part 15 B requirements if needed.

Important Note

notice that any deviation(s) from the defined parameters of the antenna trace, as described by the instructions, require that the host product manufacturer must notify to Quectel that they wish to change the antenna trace design. In this case, a Class II permissive change application is required to be filed by the USI, or the host manufacturer can take responsibility through the change in FCC ID (new application) procedure followed by a Class II permissive change application

End Product Labeling

When the module is installed in the host device, the FCC/IC ID label must be visible through a window on the final device or it must be visible when an access panel, door or cover is easily re-moved. If not, a second label must be placed on the outside of the final device that contains the following text: "Contains FCC ID: XMR2021BC660KGL" "Contains IC: 10224A-2021BC660GL". The FCC ID/IC ID can be used only when all FCC/IC compliance requirements are met.

Antenna

- (1) The antenna must be installed such that 20 cm is maintained between the antenna and users,
- (2) The transmitter module may not be co-located with any other transmitter or antenna.

In the event that these conditions cannot be met (for example certain laptop configurations or co-location with another transmitter), then the FCC/IC authorization is no longer considered valid and the FCC ID/IC ID cannot be used on the final product. In these circumstances, the OEM integrator will be responsible for re-evaluating the end product (including the transmitter) and obtaining a separate FCC/IC authorization.

To comply with FCC regulations limiting both maximum RF output power and human exposure to RF radiation, maximum antenna gain (including cable loss) must not exceed

Test Mode	Antenna Gain (dBi)	Test Mode	Antenna Gain (dBi)
NB-IoT Band 2	8.00	NB-IoT Band 17	5.00
NB-IoT Band 4*	8.00	NB-IoT Band 25	8.00
NB-IoT Band 5	5.00	NB-IoT Band 66*	8.00
NB-IoT Band 12	5.00	NB-IoT Band 85	5.00
NB-IoT Band 13	5.00		

Note: "*" means when using these max gain antenna, the host manufacturer should reduce the conducted power to meet the FCC maximum RF output power limit.

Manual Information to the End User

The OEM integrator has to be aware not to provide information to the end user regarding how to install or remove this RF module in the user's manual of the end product which integrates this module. The end user manual shall include all required regulatory information/warning as show in this manual

Federal Communication Commission Interference Statement

This device complies with Part 15 of the FCC Rules. Operation is subject to the following two conditions:

(1) This device may not cause harmful interference, and (2) this device must accept any interference received, including interference that may cause undesired operation.

This equipment has been tested and found to comply with the limits for a Class B digital device, pursuant to Part 15 of the FCC Rules. These limits are designed to provide reasonable protection against harmful interference in a residential installation. This equipment generates, uses and can radiate radio frequency energy and, if not installed and used in accordance with the instructions, may cause harmful interference to radio communications. However, there is no guarantee that interference will not occur in a particular installation. If this equipment does cause harmful interference to radio or television reception, which can be determined by turning the equipment off and on, the user is encouraged to try to correct the interference by one of the following measures:

- Reorient or relocate the receiving antenna.
- Increase the separation between the equipment and receiver
- Connect the equipment into an outlet on a circuit different from that to which the receiver is connected.
- Consult the dealer or an experienced radio/TV technician for help.

Any changes or modifications not expressly approved by the party responsible for compliance could void the user's authority to operate this equipment. This transmitter must not be co-located or operating in conjunction with any other antenna or transmitter.

List of applicable FCC rules

This module has been tested and found to comply with part 22, part 24, part 27, part 90 requirements for Modular Approval.

The modular transmitter is only FCC authorized for the specific rule parts (i.e., FCC transmitter rules) listed on the grant, and that the host product manufacturer is responsible for compliance to any other FCC rules that apply to the host not covered by the modular transmitter grant of certification. If the grantee markets their product as being Part 15 Subpart B compliant (when it also contains unintentional-radiator digital circuitry), then the grantee shall provide a notice stating that the final host product still requires Part 15 Subpart B compliance testing with the modular transmitter installed.

This device is intended only for OEM integrators under the following

conditions: (For module device use)

- 1) The antenna must be installed such that 20 cm is maintained between the antenna and users, and
- 2) The transmitter module may not be co-located with any other transmitter or antenna.

As long as 2 conditions above are met, further transmitter test will not be required. However, the OEM integrator is still responsible for testing their end-product for any additional compliance requirements required with this module installed.

Radiation Exposure Statement

This equipment complies with FCC radiation exposure limits set forth for an uncontrolled environment.

This equipment should be installed and operated with minimum distance 20 cm between the radiator & your body.

Industry Canada Statement

This device complies with Industry Canada's licence-exempt RSSs. Operation is subject to the following two conditions:

- (1) This device may not cause interference; and
- (2) This device must accept any interference, including interference that may cause undesired operation of the device.

Le présent appareil est conforme aux CNR d'Industrie Canada applicables aux appareils radio exempts de licence. L'exploitation est autorisée aux deux conditions suivantes:

- (1) l'appareil ne doit pas produire de brouillage, et
- (2) l'utilisateur de l'appareil doit accepter tout brouillage radioélectrique subi, même si le brouillage est susceptible d'en compromettre le fonctionnement."

Radiation Exposure Statement

This equipment complies with IC radiation exposure limits set forth for an uncontrolled environment. This equipment should be installed and operated with minimum distance 20 cm between the radiator & your body

Déclaration d'exposition aux radiations:

Cet équipement est conforme aux limites d'exposition aux rayonnements ISED établies pour un environnement non contrôlé. Cet équipement doit être installé et utilisé avec un minimum de 20 cm de distance entre la source de rayonnement et votre corps.

This device is intended only for OEM integrators under the following conditions: (For module device use)

- 1) The antenna must be installed such that 20 cm is maintained between the antenna and users, and
- 2) The transmitter module may not be co-located with any other transmitter or antenna. As long as 2 conditions above are met, further transmitter test will not be required. However, the OEM integrator is still responsible for testing their end-product for any additional compliance requirements required with this module installed.

Cet appareil est conçu uniquement pour les intégrateurs OEM dans les conditions suivantes: (Pour utilisation de dispositif module)

- 1) L'antenne doit être installée de telle sorte qu'une distance de 20 cm est respectée entre l'antenne et les utilisateurs, et
- 2) Le module émetteur peut ne pas être coïmplanté avec un autre émetteur ou antenne.

Tant que les 2 conditions ci-dessus sont remplies, des essais supplémentaires sur l'émetteur ne seront pas nécessaires. Toutefois, l'intégrateur OEM est toujours responsable des essais sur son produit final pour toutes exigences de conformité supplémentaires requis pour ce module installé.

IMPORTANT NOTE:

In the event that these conditions cannot be met (for example certain laptop configurations or colocation with another transmitter), then the Canada authorization is no longer considered valid and the IC ID cannot be used on the final product. In these circumstances, the OEM integrator will be responsible for re-evaluating the end product (including the transmitter) and obtaining a separate Canada authorization.

NOTE IMPORTANTE:

Dans le cas où ces conditions ne peuvent être satisfaites (par exemple pour certaines configurations d'ordinateur portable ou de certaines co-localisation avec un autre émetteur), l'autorisation du Canada n'est plus considéré comme valide et l'ID IC ne peut pas être utilisé sur le produit final. Dans ces circonstances, l'intégrateur OEM sera chargé de réévaluer le produit final (y compris l'émetteur) et l'obtention d'une autorisation distincte au Canada.

End Product Labeling

This transmitter module is authorized only for use in device where the antenna may be installed such that 20 cm may be maintained between the antenna and users. The final end product must be labeled in a visible area with the following: "Contains IC: 10224A-2021BC660GL".

Plaque signalétique du produit final

Ce module émetteur est autorisé uniquement pour une utilisation dans un dispositif où l'antenne peut être installée de telle sorte qu'une distance de 20cm peut être maintenue entre l'antenne et les utilisateurs. Le produit final doit être étiqueté dans un endroit visible avec l'inscription suivante: "Contient des IC: 10224A-2021BC660GL".

Manual Information to the End User

The OEM integrator has to be aware not to provide information to the end user regarding how to install or remove this RF module in the user's manual of the end product which integrates this module.

The end user manual shall include all required regulatory information/warning as show in this manual.

Manuel d'information à l'utilisateur final

L'intégrateur OEM doit être conscient de ne pas fournir des informations à l'utilisateur final quant à la façon d'installer ou de supprimer ce module RF dans le manuel de l'utilisateur du produit final qui intègre ce module.

Le manuel de l'utilisateur final doit inclure toutes les informations réglementaires requises et avertissements comme indiqué dans ce manuel.