

BG95-M1

Hardware

Design

LPWA Module Series

Rev. BG95_Hardware_Design_V1.0

Date: 2019-05-15

Status: Preliminary

Our aim is to provide customers with timely and comprehensive service. For any assistance, please contact our company headquarters:

Quectel Wireless Solutions Co., Ltd.

7th Floor, Hongye Building, No.1801 Hongmei Road, Xuhui District, Shanghai 200233, China

Tel: +86 21 5108 6236

Email: info@quectel.com

Or our local office. For more information, please visit:

<http://www.quectel.com/support/sales.htm>

For technical support, or to report documentation errors, please visit:

<http://www.quectel.com/support/technical.htm>

Or email to: support@quectel.com

GENERAL NOTES

QUECTEL OFFERS THE INFORMATION AS A SERVICE TO ITS CUSTOMERS. THE INFORMATION PROVIDED IS BASED UPON CUSTOMERS' REQUIREMENTS. QUECTEL MAKES EVERY EFFORT TO ENSURE THE QUALITY OF THE INFORMATION IT MAKES AVAILABLE. QUECTEL DOES NOT MAKE ANY WARRANTY AS TO THE INFORMATION CONTAINED HEREIN, AND DOES NOT ACCEPT ANY LIABILITY FOR ANY INJURY, LOSS OR DAMAGE OF ANY KIND INCURRED BY USE OF OR RELIANCE UPON THE INFORMATION. ALL INFORMATION SUPPLIED HEREIN IS SUBJECT TO CHANGE WITHOUT PRIOR NOTICE.

COPYRIGHT

THE INFORMATION CONTAINED HERE IS PROPRIETARY TECHNICAL INFORMATION OF QUECTEL WIRELESS SOLUTIONS CO., LTD. TRANSMITTING, REPRODUCTION, DISSEMINATION AND EDITING OF THIS DOCUMENT AS WELL AS UTILIZATION OF THE CONTENT ARE FORBIDDEN WITHOUT PERMISSION. OFFENDERS WILL BE HELD LIABLE FOR PAYMENT OF DAMAGES. ALL RIGHTS ARE RESERVED IN THE EVENT OF A PATENT GRANT OR REGISTRATION OF A UTILITY MODEL OR DESIGN.

Copyright © Quectel Wireless Solutions Co., Ltd. 2019. All rights reserved.

About the Document

History

Revision	Date	Author	Description
1.0	2019-05-15	Lim PENG/ Garey XIE	Initial

Contents

About the Document	3
Contents	4
Table Index	6
Figure Index	8
1 Introduction	9
1.1. Safety Information	10
2 Product Concept	14
2.1. General Description	14
2.2. Key Features	16
2.3. Functional Diagram	19
2.4. Evaluation Board	20
3 Application Interfaces	22
3.1. Pin Assignment	23
3.2. Pin Description	24
3.3. Operating Modes	31
3.4. Power Saving	32
3.4.1. Airplane Mode	32
3.4.2. Power Saving Mode (PSM)	33
3.4.3. Extended Idle Mode DRX (e-I-DRX)	34
3.4.4. Sleep Mode*	34
3.4.4.1. UART Application	34
3.5. Power Supply	35
3.5.1. Power Supply Pins	35
3.5.2. Decrease Voltage Drop	36
3.5.3. Monitor the Power Supply	37
3.6. Turn on and off Scenarios	37
3.6.1. Turn on Module Using the PWRKEY Pin	37
3.6.2. Turn off Module	39
3.6.2.1. Turn off Module Using the PWRKEY Pin	39
3.6.2.2. Turn off Module Using AT Command	40
3.7. Reset the Module	40
3.8. (U)SIM Interface	42
3.9. USB Interface	44
3.10. UART Interfaces	46
3.11. PCM* and I2C* Interfaces	49
3.12. Network Status Indication	50
3.13. STATUS	51
3.14. Behaviors of RI*	51
3.15. USB_BOOT Interface	52
3.16. ADC Interfaces	53

3.17.	GPIO Interfaces.....	54
4	GNSS Receiver	56
4.1.	General Description.....	56
4.2.	GNSS Performance.....	56
4.3.	Layout Guidelines.....	57
5	Antenna Interfaces.....	58
5.1.	Main Antenna Interface	58
5.1.1.	Pin Definition.....	58
5.1.2.	Operating Frequency	58
5.1.3.	Reference Design of RF Antenna Interface	59
5.1.4.	Reference Design of RF Layout.....	60
5.2.	GNSS Antenna Interface	62
5.3.	Antenna Installation	63
5.3.1.	Antenna Requirements	63
5.3.2.	Recommended RF Connector for Antenna Installation.....	64
6	Electrical, Reliability and Radio Characteristics	66
6.1.	Absolute Maximum Ratings.....	66
6.2.	Power Supply Ratings	66
6.3.	Operation and Storage Temperatures	67
6.4.	RF Output Power.....	67
6.5.	RF Receiving Sensitivity.....	68
6.6.	Electrostatic Discharge.....	69
7	Mechanical Dimensions.....	71
7.1.	Mechanical Dimensions of the Module	71
7.2.	Recommended Footprint.....	73
7.3.	Design Effect Drawings of the Module.....	74
8	Storage, Manufacturing and Packaging	75
8.1.	Storage.....	75
8.2.	Manufacturing and Soldering.....	76
8.3.	Packaging.....	77
9	Appendix A References	79
10	Appendix B GPRS Coding Schemes	82
11	Appendix C GPRS Multi-slot Classes.....	83
12	Appendix D EDGE Modulation and Coding Schemes.....	85

Table Index

TABLE 1: VERSION SELECTION FOR BG95 SERIES MODULE	14
TABLE 2: FREQUENCY BANDS AND GNSS TYPES OF BG95 SERIES MODULE	14
TABLE 3: KEY FEATURES OF BG95 SERIES MODULES	17
TABLE 4: DEFINITION OF I/O PARAMETERS	24
TABLE 5: PIN DESCRIPTION.....	25
TABLE 6: OVERVIEW OF OPERATING MODES	32
TABLE 7: VBAT AND GND PINS	36
TABLE 8: PIN DEFINITION OF PWRKEY	38
TABLE 9: PIN DEFINITION OF RESET_N	40
TABLE 10: PIN DEFINITION OF (U)SIM INTERFACE.....	42
TABLE 11: PIN DEFINITION OF USB INTERFACE.....	44
TABLE 12: PIN DEFINITION OF MAIN UART INTERFACE	46
TABLE 13: PIN DEFINITION OF DEBUG UART INTERFACE.....	47
TABLE 14: PIN DEFINITION OF GNSS UART INTERFACE	47
TABLE 15: LOGIC LEVELS OF DIGITAL I/O	47
TABLE 16: PIN DEFINITION OF PCM AND I2C INTERFACES	49
TABLE 17: PIN DEFINITION OF NETLIGHT	50
TABLE 18: WORKING STATE OF NETLIGHT	50
TABLE 19: PIN DEFINITION OF STATUS	51
TABLE 20: DEFAULT BEHAVIORS OF RI	52
TABLE 21: PIN DEFINITION OF USB_BOOT INTERFACE.....	52
TABLE 22: PIN DEFINITION OF ADC INTERFACE.....	53
TABLE 23: CHARACTERISTICS OF ADC INTERFACES.....	54
TABLE 24: PIN DEFINITION OF GPIO INTERFACES.....	54
TABLE 25: LOGIC LEVELS OF GPIO INTERFACES	55
TABLE 26: GNSS PERFORMANCE	56
TABLE 27: PIN DEFINITION OF MAIN ANTENNA INTERFACE.....	58
TABLE 28: BG95 OPERATING FREQUENCY	58
TABLE 29: PIN DEFINITION OF GNSS ANTENNA INTERFACE.....	62
TABLE 30: GNSS FREQUENCY	62
TABLE 31: ANTENNA REQUIREMENTS	63
TABLE 32: ABSOLUTE MAXIMUM RATINGS	66
TABLE 33: POWER SUPPLY RATINGS	66
TABLE 34: OPERATION AND STORAGE TEMPERATURES.....	67
TABLE 35: BG95 RF OUTPUT POWER.....	68
TABLE 36: BG95 CONDUCTED RF RECEIVING SENSITIVITY	68
TABLE 37: ELECTROSTATIC DISCHARGE CHARACTERISTICS (25°C, 45% RELATIVE HUMIDITY)	70
TABLE 38: RECOMMENDED THERMAL PROFILE PARAMETERS	76
TABLE 39: REEL PACKAGING	78
TABLE 40: RELATED DOCUMENTS	79
TABLE 41: TERMS AND ABBREVIATIONS.....	79

TABLE 42: DESCRIPTION OF DIFFERENT CODING SCHEMES..... 82
TABLE 43: GPRS MULTI-SLOT CLASSES 83
TABLE 44: EDGE MODULATION AND CODING SCHEMES 85

Figure Index

FIGURE 1: FUNCTIONAL DIAGRAM	20
FIGURE 2: PIN ASSIGNMENT (TOP VIEW)	23
FIGURE 3: SLEEP MODE APPLICATION VIA UART	35
FIGURE 4: POWER SUPPLY LIMITS DURING BURST TRANSMISSION	36
FIGURE 5: STAR STRUCTURE OF THE POWER SUPPLY	37
FIGURE 6: TURN ON THE MODULE USING DRIVING CIRCUIT	38
FIGURE 7: TURN ON THE MODULE USING KEYSTROKE	38
FIGURE 8: TIMING OF TURNING ON MODULE	39
FIGURE 9: TIMING OF TURNING OFF MODULE	40
FIGURE 10: TIMING OF RESET MODULE	41
FIGURE 11: REFERENCE CIRCUIT OF RESET_N BY USING DRIVING CIRCUIT	41
FIGURE 12: REFERENCE CIRCUIT OF RESET_N BY USING BUTTON	41
FIGURE 13: REFERENCE CIRCUIT OF (U)SIM INTERFACE WITH AN 8-PIN (U)SIM CARD CONNECTOR	43
FIGURE 14: REFERENCE CIRCUIT OF (U)SIM INTERFACE WITH A 6-PIN (U)SIM CARD CONNECTOR	43
FIGURE 15: REFERENCE CIRCUIT OF USB INTERFACE	45
FIGURE 16: REFERENCE CIRCUIT WITH TRANSLATOR CHIP	48
FIGURE 17: REFERENCE CIRCUIT WITH TRANSISTOR CIRCUIT	48
FIGURE 18: REFERENCE CIRCUIT OF PCM APPLICATION WITH AUDIO CODEC	49
FIGURE 19: REFERENCE CIRCUIT OF THE NETWORK STATUS INDICATOR	50
FIGURE 20: REFERENCE CIRCUIT OF STATUS	51
FIGURE 21: REFERENCE CIRCUIT OF USB_BOOT INTERFACE	53
FIGURE 22: REFERENCE CIRCUIT OF RF ANTENNA INTERFACE	60
FIGURE 23: MICROSTRIP LINE DESIGN ON A 2-LAYER PCB	60
FIGURE 24: COPLANAR WAVEGUIDE LINE DESIGN ON A 2-LAYER PCB	61
FIGURE 25: COPLANAR WAVEGUIDE LINE DESIGN ON A 4-LAYER PCB (LAYER 3 AS REFERENCE GROUND)	61
FIGURE 26: COPLANAR WAVEGUIDE LINE DESIGN ON A 4-LAYER PCB (LAYER 4 AS REFERENCE GROUND)	61
FIGURE 27: REFERENCE CIRCUIT OF GNSS ANTENNA INTERFACE	63
FIGURE 28: DIMENSIONS OF THE U.FL-R-SMT CONNECTOR (UNIT: MM)	64
FIGURE 29: MECHANICALS OF U.FL-LP CONNECTORS	65
FIGURE 30: SPACE FACTOR OF MATED CONNECTOR (UNIT: MM)	65
FIGURE 31: MODULE TOP AND SIDE DIMENSIONS	71
FIGURE 32: MODULE BOTTOM DIMENSIONS (BOTTOM VIEW)	72
FIGURE 33: RECOMMENDED FOOTPRINT (TOP VIEW)	73
FIGURE 34: TOP VIEW OF THE MODULE	74
FIGURE 35: BOTTOM VIEW OF THE MODULE	74
FIGURE 36: RECOMMENDED REFLOW SOLDERING THERMAL PROFILE	76
FIGURE 37: TAPE DIMENSIONS	77
FIGURE 38: REEL DIMENSIONS	78

1 Introduction

This document defines BG95 module and describes its air interface and hardware interfaces which are connected with customers' applications.

This document can help customers quickly understand the interface specifications, electrical and mechanical details, as well as other related information of BG95. To facilitate its application in different fields, reference design is also provided for customers' reference. Associated with application notes and user guides, customers can use the module to design and set up mobile applications easily.

1.1. Safety Information

The following safety precautions must be observed during all phases of the operation, such as usage, service or repair of any cellular terminal or mobile incorporating BG95. Manufacturers of the cellular terminal should send the following safety information to users and operating personnel, and incorporate these guidelines into all manuals supplied with the product. If not so, Quectel assumes no liability for customers' failure to comply with these precautions.



Full attention must be given to driving at all times in order to reduce the risk of an accident. Using a mobile while driving (even with a handsfree kit) causes distraction and can lead to an accident. Please comply with laws and regulations restricting the use of wireless devices while driving.



Switch off the cellular terminal or mobile before boarding an aircraft. The operation of wireless appliances in an aircraft is forbidden to prevent interference with communication systems. If the device offers an Airplane Mode, then it should be enabled prior to boarding an aircraft. Please consult the airline staff for more restrictions on the use of wireless devices on boarding the aircraft.



Wireless devices may cause interference on sensitive medical equipment, so please be aware of the restrictions on the use of wireless devices when in hospitals, clinics or other healthcare facilities.



Cellular terminals or mobiles operating over radio signals and cellular network cannot be guaranteed to connect in all possible conditions (for example, with unpaid bills or with an invalid (U)SIM card). When emergent help is needed in such conditions, please remember using emergency call. In order to make or receive a call, the cellular terminal or mobile must be switched on in a service area with adequate cellular signal strength.



The cellular terminal or mobile contains a transmitter and receiver. When it is ON, it receives and transmits radio frequency signals. RF interference can occur if it is used close to TV set, radio, computer or other electric equipment.



In locations with potentially explosive atmospheres, obey all posted signs to turn off wireless devices such as your phone or other cellular terminals. Areas with potentially explosive atmospheres include fueling areas, below decks on boats, fuel or chemical transfer or storage facilities, areas where the air contains chemicals or particles such as grain, dust or metal powders, etc.

1.2. FCC Certification Requirements.

According to the definition of mobile and fixed device is described in Part 2.1091(b), this device is a mobile device.

And the following conditions must be met:

1. This Modular Approval is limited to OEM installation for mobile and fixed applications only. The antenna installation and operating configurations of this transmitter, including any applicable source-based time-averaging duty factor, antenna gain and cable loss must satisfy MPE categorical Exclusion Requirements of 2.1091.

2. The EUT is a mobile device; maintain at least a 20 cm separation between the EUT and the user's body and must not transmit simultaneously with any other antenna or transmitter.

3. A label with the following statements must be attached to the host end product: This device contains FCC ID: XMR2020BG95M1.

4. To comply with FCC regulations limiting both maximum RF output power and human exposure to RF radiation, maximum antenna gain (including cable loss) must not exceed:

- Catm LTE Band2/25: ≤ 11.000 dBi
- Catm LTE Band4/66: ≤ 8.000 dBi
- Catm LTE Band5/26: ≤ 12.541 dBi
- Catm LTE Band12/85: ≤ 11.798 dBi
- Catm LTE Band13: ≤ 12.214 dBi
- Catm LTE Band14: ≤ 12.272 dBi

5. This module must not transmit simultaneously with any other antenna or transmitter

6. The host end product must include a user manual that clearly defines operating requirements and conditions that must be observed to ensure compliance with current FCC RF exposure guidelines.

For portable devices, in addition to the conditions 3 through 6 described above, a separate approval is required to satisfy the SAR requirements of FCC Part 2.1093

If the device is used for other equipment that separate approval is required for all other operating configurations, including portable configurations with respect to 2.1093 and different antenna configurations.

For this device, OEM integrators must be provided with labeling instructions of finished products.

Please refer to KDB784748 D01 v07, section 8. Page 6/7 last two paragraphs:

A certified modular has the option to use a permanently affixed label, or an electronic label. For a permanently affixed label, the module must be labeled with an FCC ID - Section 2.926 (see 2.2 Certification (labeling requirements) above). The OEM manual must provide clear instructions explaining to the OEM the labeling requirements, options and OEM user manual instructions that are required (see next paragraph).

For a host using a certified modular with a standard fixed label, if (1) the module's FCC ID is not visible when installed in the host, or (2) if the host is marketed so that end users do not have straightforward commonly used methods for access to remove the module so that the FCC ID of the module is visible; then an additional permanent label referring to the enclosed module: "Contains Transmitter Module FCC ID: XMR2020BG95M1" or "Contains FCC ID: XMR2020BG95M1" must be used. The host OEM user manual must also contain clear instructions on how end users can find and/or access the module and the FCC ID.

The final host / module combination may also need to be evaluated against the FCC Part 15B criteria for unintentional radiators in order to be properly authorized for operation as a Part 15 digital device.

The user's manual or instruction manual for an intentional or unintentional radiator shall caution the user that changes or modifications not expressly approved by the party responsible for compliance could void the user's authority to operate the equipment. In cases where the manual is provided only in a form other than paper, such as on a computer disk or over the Internet, the information required by this section may be included in the manual in that alternative form, provided the user can reasonably be expected to have the capability to access information in that form.

This device complies with part 15 of the FCC Rules. Operation is subject to the following two conditions:

(1) This device may not cause harmful interference, and (2) this device must accept any interference received, including interference that may cause undesired operation.

Changes or modifications not expressly approved by the manufacturer could void the user's authority to operate the equipment.

2 Product Concept

2.1. General Description

BG95 is a series of embedded IoT (LTE Cat M1, LTE Cat NB2 and EGPRS) wireless communication module. It provides data connectivity on LTE-FDD/GPRS/EGPRS networks, and supports half-duplex operation in LTE networks. It also provides GNSS ¹⁾ and voice ²⁾ functionality to meet customers' specific application demands.

Table 1: Version Selection for BG95 Series Module

Version	Cat M1	VoLTE	Cat NB2 ^{3)/} NB1	GSM	Wi-Fi Positioning	GNSS (Optional)
BG95-M1	Y	Y	N	N	N	Y
BG95-M2*	Y	Y	Y	N	N	Y
BG95-M3*	Y	Y	Y	Y	N	Y
BG95-N1*	N	N	Y	N	N	Y
BG95-M4 ⁴⁾	Y	Y	Y	N	N	Y
BG95-M5 ⁴⁾	Y	Y	Y	N	N	Y
BG95-MF ⁴⁾	Y	Y	Y	N	Y	Y

Table 2: Frequency Bands and GNSS Types of BG95 Series Module

Module	Supported Bands	LTE Bands Power Class	GNSS (Optional)
BG95-M1	Cat M1 Only: LTE-FDD: B1/B2/B3/B4/B5/B8/B12/B13/ B14/B18/B19/B20/B25/B26*/B27/ B28/B66/B85	Power Class 5 (20dBm)	GPS, GLONASS, BeiDou, Galileo

BG95-M2*	<p>Cat M1: LTE-FDD: B1/B2/B3/B4/B5/B8/B12/B13/ B14/B18/B19/B20/B25/B26*/ B27/B28/B66/B85</p> <p>Cat NB2: LTE-FDD: B1/B2/B3/B4/B5/B8/B12/B13/ B18/B19/B20/B25/B26*/B28/B66/ B71/B85</p>	Power Class 5 (20dBm)	GPS, GLONASS, BeiDou, Galileo
BG95-M3*	<p>Cat M1: LTE-FDD: B1/B2/B3/B4/B5/B8/B12/B13/ B14/B18/B19/B20/B25/B26*/B27/ B28/B66/B85</p> <p>Cat NB2: LTE-FDD: B1/B2/B3/B4/B5/B8/B12/B13/ B18/B19/B20/B25/B26*/ B28/B66/B71/B85</p> <p>EGPRS: 850/900/1800/1900MHz</p>	Power Class 5 (20dBm)	GPS, GLONASS, BeiDou, Galileo
BG95-N1*	<p>Cat NB2 Only: LTE FDD: B1/B2/B3/B4/B5/B8/B12/B13/ B18/B19/B20/B25/B26*/ B28/B66/B71/B85</p>	Power Class 5 (20dBm)	GPS, GLONASS, BeiDou, Galileo
BG95-M4 ⁴⁾	<p>Cat M1: LTE-FDD: B1/B2/B3/B4/B5/B8/B12/B13/ B14/B18/B19/B20/B25/B26/B27/ B28/B31/B66/B72/B73/B85</p> <p>Cat NB2: LTE-FDD: B1/B2/B3/B4/B5/B8/B12/B13/ B18/B19/B20/B25/B26/B28/B31/ B66/B72/B73/B85</p>	Power Class 5 (20dBm)	GPS, GLONASS, BeiDou, Galileo
BG95-M5 ⁴⁾	<p>Cat M1: LTE-FDD: B1/B2/B3/B4/B5/B8/B12/B13/ B14/B18/B19/B20/B25/B26/B27/ B28/B66/B85</p> <p>Cat NB2: LTE-FDD:</p>	Power Class 3 (23dBm)	GPS, GLONASS, BeiDou, Galileo

	B1/B2/B3/B4/B5/B8/B12/B13/ B18/B19/B20/B25/B26/B28/B66/ B71/B85		
BG95-MF ⁴⁾	<p>Cat M1: LTE-FDD: B1/B2/B3/B4/B5/B8/B12/B13/ B14/B18/B19/B20/B25/B26/B27/ B28/B66/B85</p> <p>Cat NB2: LTE-FDD: B1/B2/B3/B4/B5/B8/B12/B13/ B18/B19/B20/B25/B26/ B28/B66/B71/B85</p> <p>Wi-Fi (For Positioning Only): 2.4GHz/5GHz</p>	Power Class 5 (20dBm)	GPS, GLONASS, BeiDou, Galileo

NOTES

- ¹⁾ GNSS function is optional.
- ²⁾ BG95 series module supports VoLTE (Voice over LTE) under LTE Cat M1 and CS voice under GSM.
- ³⁾ LTE Cat NB2 is backward compatible with LTE Cat NB1.
- ⁴⁾ BG95-M4/-M5/-MF are still under planning. Therefore, details of them are currently not included and will be added in a future release of this document.
- "*" means under development.

With a compact profile of 23.6mm × 19.9mm × 2.2mm, BG95 can meet almost all requirements for M2M applications such as smart metering, tracking system, security, wireless POS, etc.

BG95 is an SMD type module which can be embedded into applications through its 102 LGA pads. It supports internet service protocols like TCP, UDP and PPP. Extended AT commands have been developed for customers to use these internet service protocols easily.

2.2. Key Features

The following table describes the detailed features of BG95 series modules.

Table 3: Key Features of BG95 Series Modules

Features	Details
Power Supply	<p>BG95-M1/-M2/-N1:</p> <ul style="list-style-type: none"> ● Supply voltage: 2.4V~4.8V ● Typical supply voltage: 3.3V <p>BG95-M3:</p> <ul style="list-style-type: none"> ● Supply voltage: 3.3V~4.3V ● Typical supply voltage: 3.8V
Transmitting Power	<p>Class 5 (20dBm±2dB) for LTE-FDD bands Class 4 (33dBm±2dB) for GSM850 Class 4 (33dBm±2dB) for EGSM900 Class 1 (30dBm±2dB) for DCS1800 Class 1 (30dBm±2dB) for PCS1900 Class E2 (27dBm±3dB) for GSM850 8-PSK Class E2 (27dBm±3dB) for EGSM900 8-PSK Class E2 (26dBm±3dB) for DCS1800 8-PSK Class E2 (26dBm±3dB) for PCS1900 8-PSK</p>
LTE Features	<p>Support LTE Cat M1 and LTE Cat NB2 Support 1.4MHz RF bandwidth for LTE Cat M1 Support 200KHz RF bandwidth for LTE Cat NB2 Support SISO in DL direction Cat M1: Max. 589Kbps (DL)/1.12Mbps (UL) Cat NB2: Max. 136Kbps (DL)/150Kbps (UL)</p>
GSM Features	<p>GPRS:</p> <ul style="list-style-type: none"> ● Support GPRS multi-slot class 33 (33 by default) ● Coding scheme: CS-1, CS-2, CS-3 and CS-4 ● Max. 107Kbps (DL), Max. 85.6Kbps (UL) <p>EDGE:</p> <ul style="list-style-type: none"> ● Support EDGE multi-slot class 33 (33 by default) ● Support GMSK and 8-PSK for different MCS (Modulation and Coding Scheme) ● Downlink coding schemes: CS 1-4 and MCS 1-9 ● Uplink coding schemes: CS 1-4 and MCS 1-9 ● Max. 296Kbps (DL), Max. 236.8Kbps (UL)
Internet Protocol Features*	<p>Support PPP/TCP/UDP/SSL/TLS/FTP(S)/HTTP(S)/NITZ/PING/MQTT/CoAP protocols Support PAP (Password Authentication Protocol) and CHAP (Challenge Handshake Authentication Protocol) protocols which are usually used for PPP connections</p>
SMS	<p>Text and PDU mode Point to point MO and MT SMS cell broadcast</p>

	SMS storage: ME by default
(U)SIM Interface	Support 1.8V USIM/SIM card
Audio Feature*	Support one digital audio interface: PCM interface
USB Interface	Compliant with USB 2.0 specification (slave only) Support operations at low-speed and full-speed Used for AT command communication, data transmission, GNSS NMEA output, software debugging and firmware upgrade Support USB serial drivers for Windows 7/8/8.1/10, Linux 2.6/3.x (3.4 or later)/4.1~4.15, Android 4.x/5.x/6.x/7.x/8.x/9.x
UART Interfaces	<p>Main UART:</p> <ul style="list-style-type: none"> ● Used for data transmission and AT command communication ● 115200bps baud rate by default ● The default frame format is 8N1 (8 data bits, no parity, 1 stop bit) ● Support RTS and CTS hardware flow control <p>Debug UART:</p> <ul style="list-style-type: none"> ● Used for software debugging and log output ● Support 115200bps baud rate <p>GNSS UART:</p> <ul style="list-style-type: none"> ● Used for GNSS data and NMEA sentences output ● 115200bps baud rate by default
AT Commands	3GPP TS 27.007 and 3GPP TS 27.005 AT commands, as well as Quectel enhanced AT commands
Network Indication	One NETLIGHT pin for network connectivity status indication
Antenna Interfaces	Including main antenna (ANT_MAIN) and GNSS antenna (ANT_GNSS) interfaces
Physical Characteristics	Size: (23.6±0.15)mm × (19.9±0.15)mm × (2.2±0.2)mm Weight: approx. 2.15g
Temperature Range	Operation temperature range: -35°C ~ +75°C ¹⁾ Extended temperature range: -40°C ~ +85°C ²⁾ Storage temperature range: -40°C ~ +90°C
Firmware Upgrade	USB interface, DFOTA*
RoHS	All hardware components are fully compliant with EU RoHS directive

NOTES

1. “*” means under development.
2. ¹⁾ Within operation temperature range, the module is 3GPP compliant.
3. ²⁾ Within extended temperature range, the module remains the ability to establish and maintain a voice, SMS, data transmission, emergency call, etc. There is no unrecoverable malfunction. There are also no effects on radio spectrum and no harm to radio network. Only one or more parameters like P_{out} might reduce in their value and exceed the specified tolerances. When the temperature returns to the normal operating temperature levels, the module will meet 3GPP specifications again.

2.3. Functional Diagram

The following figure shows a block diagram of BG95 and illustrates the major functional parts.

- Power management
- Baseband
- Radio frequency
- Peripheral interfaces

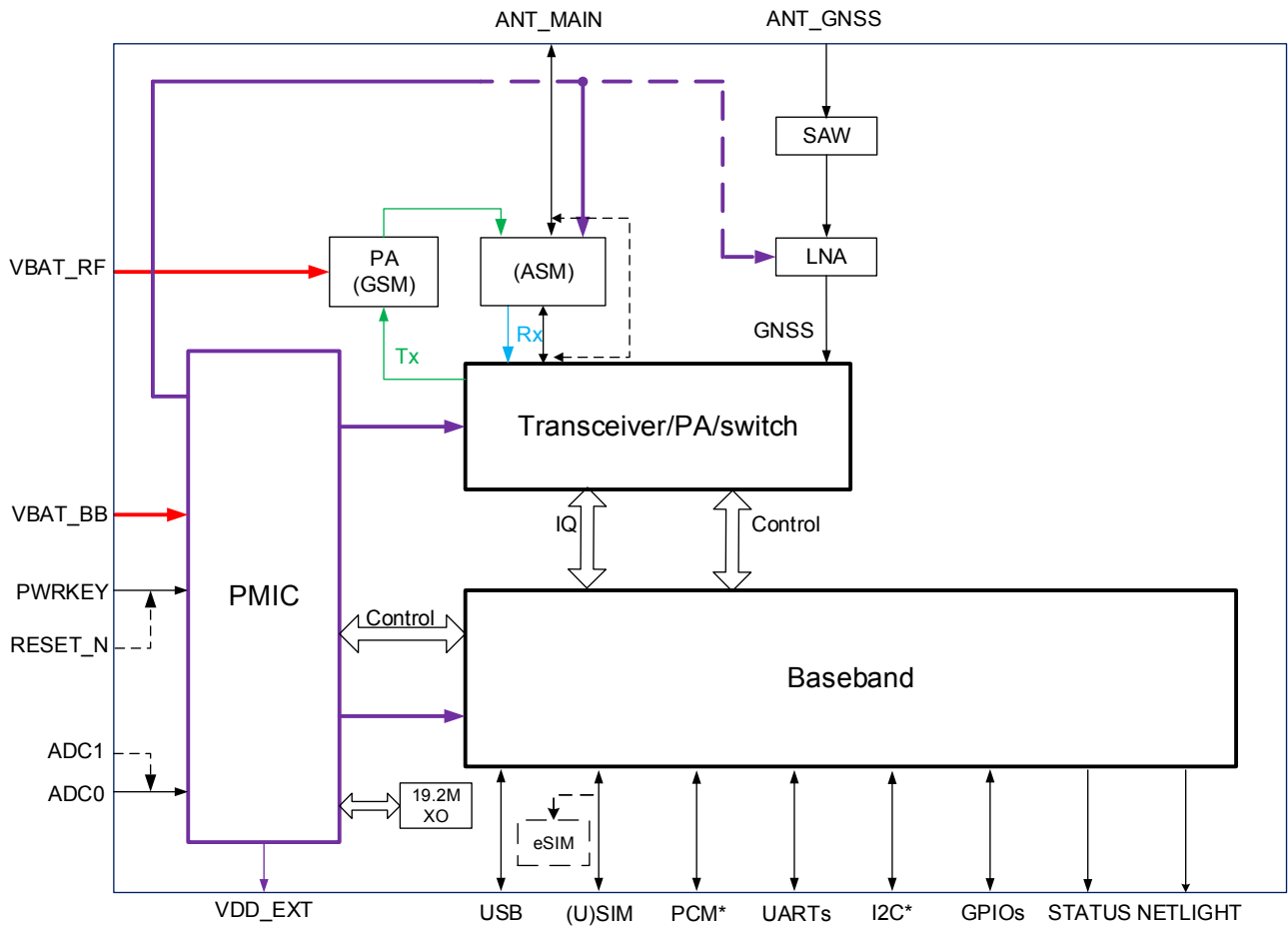

Figure 1: Functional Diagram

NOTES

1. eSIM function is optional. If eSIM is selected, then the external (U)SIM cannot be used simultaneously.
2. RESET_N will be supported in the next hardware design version.
3. ADC0 and ADC1 cannot be used simultaneously. BG95 supports using of only one ADC interface at a time: either ADC0 or ADC1. Currently only ADC0 is enabled, and ADC1 will be enabled in the next hardware design version.
4. "*" means under development.

2.4. Evaluation Board

In order to help customers to develop applications conveniently with BG95, Quectel supplies the evaluation board (EVB), USB to RS-232 converter cable, USB data cable, earphone, antenna and other

peripherals to control or test the module. For more details, please refer to **document [1]**.

3 Application Interfaces

BG95 is equipped with 102 LGA pads that can be connected to customers' cellular application platforms. The following sub-chapters will provide detailed description of interfaces listed below:

- Power supply
- (U)SIM interface
- USB interface
- UART interfaces
- PCM* and I2C* interfaces
- Status indication
- USB_BOOT interface
- ADC interfaces
- GPIO interfaces

NOTE

“*” means under development.

3.1. Pin Assignment

The following figure shows the pin assignment of BG95.

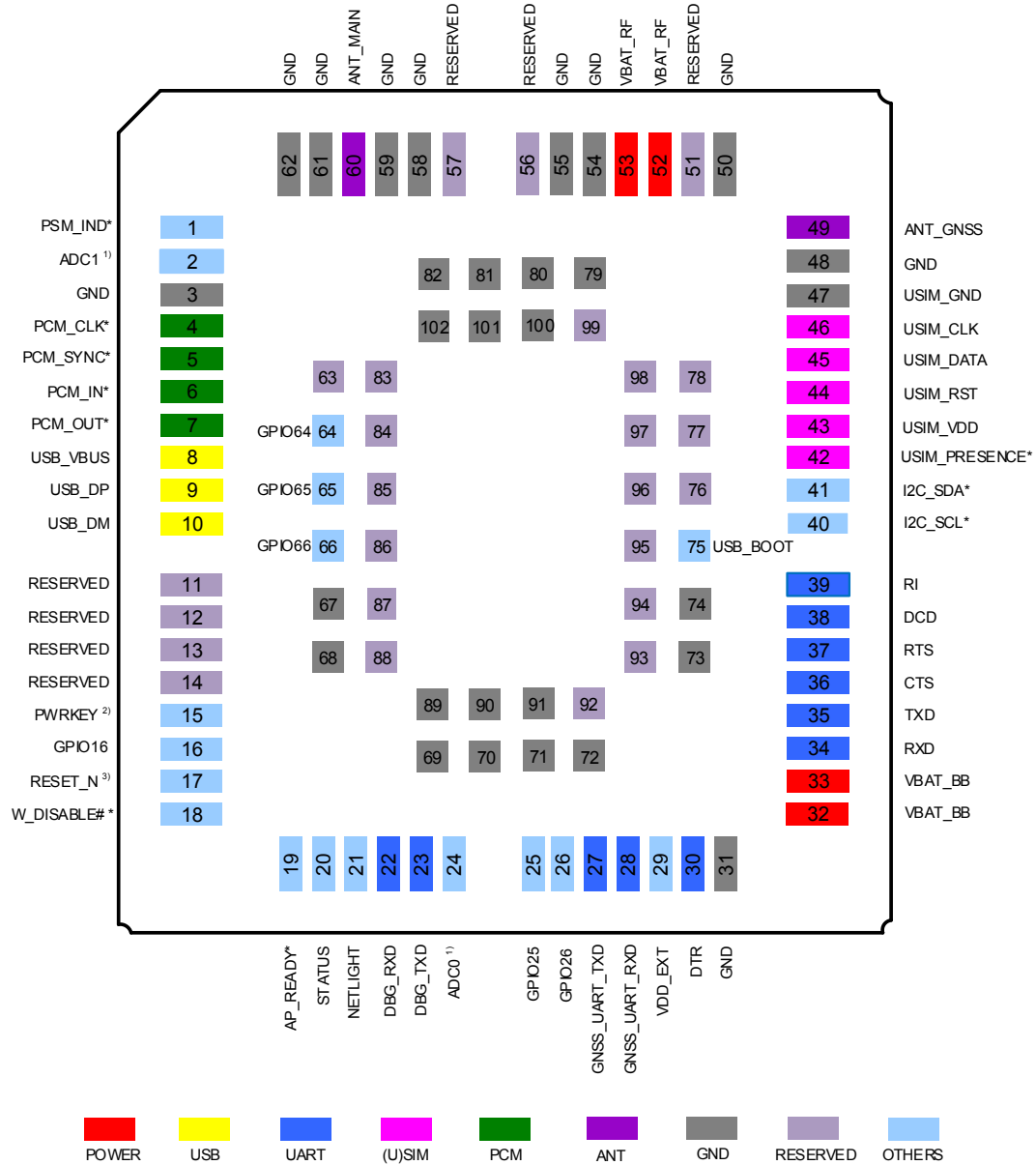

Figure 2: Pin Assignment (Top View)

NOTES

1. ¹⁾ ADC0 and ADC1 cannot be used simultaneously. BG95 supports using of only one ADC interface at a time: either ADC0 or ADC1. Currently only ADC0 is enabled, and ADC1 will be enabled in the next hardware design version.
2. ²⁾ PWRKEY output voltage is 1.5V because of the diode drop in the Qualcomm chipset. PWRKEY should never be pulled down to GND permanently.
3. ³⁾ RESET_N will be supported in the next hardware design version.
4. Keep all RESERVED pins and unused pins unconnected.
5. GND pins should be connected to ground in the design.
6. "*" means under development.

3.2. Pin Description

The following tables show the pin definition and description of BG95.

Table 4: Definition of I/O Parameters

Type	Description
AI	Analog Input
AO	Analog Output
DI	Digital Input
DO	Digital Output
IO	Bidirectional
OD	Open Drain
PI	Power Input
PO	Power Output

Table 5: Pin Description

Power Supply					
Pin Name	Pin No.	I/O	Description	DC Characteristics	Comment
VBAT_BB	32, 33	PI	Power supply for the module's baseband part	BG95-M1/-M2/-N1: Vmax=4.8V Vmin=2.4V Vnorm=3.3V	
				BG95-M3: Vmax=4.3V Vmin=3.3V Vnorm=3.8V	
VBAT_RF	52, 53	PI	Power supply for the module's RF part	BG95-M1/-M2/-N1: Vmax=4.8V Vmin=2.4V Vnorm=3.3V	
				BG95-M3: Vmax=4.3V Vmin=3.3V Vnorm=3.8V	
VDD_EXT	29	PO	1.8V output power supply for external circuit	Vnorm=1.8V I _o max=50mA	Power supply for external GPIO's pull-up circuits. If unused, keep this pin open.
GND	3, 31, 48, 50, 54, 55, 58, 59, 61, 62, 67~74, 79~82, 89~91, 100~102		Ground		
Turn on/off					
Pin Name	Pin No.	I/O	Description	DC Characteristics	Comment
PWRKEY ¹⁾	15	DI	Turn on/off the module	Vnorm=1.5V V _{IL} max=0.45V	The output voltage is 1.5V because of the diode drop in the Qualcomm chipset. PWRKEY should

never be pulled down to GND permanently.

Reset

Pin Name	Pin No.	I/O	Description	DC Characteristics	Comment
RESET_N ²⁾	17	DI	Reset the module	V _{IL} max=0.45V	RESET_N will be supported in the next hardware design version.

Status Indication

Pin Name	Pin No.	I/O	Description	DC Characteristics	Comment
STATUS	20	DO	Indicate the module's operation status	V _{OH} min=1.35V V _{OL} max=0.45V	1.8V power domain. If unused, keep this pin open.
NETLIGHT	21	DO	Indicate the module's network activity status	V _{OH} min=1.35V V _{OL} max=0.45V	1.8V power domain. If unused, keep this pin open.

USB Interface

Pin Name	Pin No.	I/O	Description	DC Characteristics	Comment
USB_VBUS	8	PI	USB detection	V _{max} =5.25V V _{min} =3.0V V _{norm} =5.0V	
USB_DP	9	IO	USB differential data bus (+)		Compliant with USB 2.0 standard specification. Require differential impedance of 90Ω.
USB_DM	10	IO	USB differential data bus (-)		

(U)SIM Interface

Pin Name	Pin No.	I/O	Description	DC Characteristics	Comment
USIM_PRESENCE*	42	DI	(U)SIM card insertion detection	V _{IL} min=-0.3V V _{IL} max=0.6V V _{IH} min=1.2V V _{IH} max=2.0V	1.8V power domain. If unused, keep this pin open.
USIM_VDD	43	PO	Power supply for (U)SIM card	V _{max} =1.9V V _{min} =1.7V	Only 1.8V (U)SIM card is supported.
USIM_RST	44	DO	Reset signal of	V _{OL} max=0.45V	

			(U)SIM card	$V_{OHmin}=1.35V$
USIM_DATA	45	IO	Data signal of (U)SIM card	$V_{ILmin}=-0.3V$ $V_{ILmax}=0.6V$ $V_{IHmin}=1.2V$ $V_{IHmax}=2.0V$ $V_{OLmax}=0.45V$ $V_{OHmin}=1.35V$
USIM_CLK	46	DO	Clock signal of (U)SIM card	$V_{OLmax}=0.45V$ $V_{OHmin}=1.35V$
USIM_GND	47		Specified ground for (U)SIM card	

Main UART Interface

Pin Name	Pin No.	I/O	Description	DC Characteristics	Comment
DTR	30	DI	Data terminal ready (sleep mode control)	$V_{ILmin}=-0.3V$ $V_{ILmax}=0.6V$ $V_{IHmin}=1.2V$ $V_{IHmax}=2.0V$	1.8V power domain. If unused, keep this pin open.
RXD	34	DI	Receive data	$V_{ILmin}=-0.3V$ $V_{ILmax}=0.6V$ $V_{IHmin}=1.2V$ $V_{IHmax}=2.0V$	1.8V power domain. If unused, keep this pin open.
TXD	35	DO	Transmit data	$V_{OLmax}=0.45V$ $V_{OHmin}=1.35V$	1.8V power domain. If unused, keep this pin open.
CTS	36	DO	Clear to send	$V_{OLmax}=0.45V$ $V_{OHmin}=1.35V$	1.8V power domain. If unused, keep this pin open.
RTS	37	DI	Request to send	$V_{ILmin}=-0.3V$ $V_{ILmax}=0.6V$ $V_{IHmin}=1.2V$ $V_{IHmax}=2.0V$	1.8V power domain. If unused, keep this pin open.
DCD	38	DO	Data carrier detection	$V_{OLmax}=0.45V$ $V_{OHmin}=1.35V$	1.8V power domain. If unused, keep this pin open.
RI	39	DO	Ring indication signal	$V_{OLmax}=0.45V$ $V_{OHmin}=1.35V$	1.8V power domain. If unused, keep this pin open.

Debug UART Interface

Pin Name	Pin No.	I/O	Description	DC Characteristics	Comment
DBG_RXD	22	DI	Receive data	V _{IL} min=-0.3V V _{IL} max=0.6V V _{IH} min=1.2V V _{IH} max=2.0V	1.8V power domain. If unused, keep this pin open.
DBG_TXD	23	DO	Transmit data	V _{OL} max=0.45V V _{OH} min=1.35V	1.8V power domain. If unused, keep this pin open.
GNSS UART Interface					
Pin Name	Pin No.	I/O	Description	DC Characteristics	Comment
GNSS_UART_TXD	27	DO	Transmit data	V _{OL} max=0.45V V _{OH} min=1.35V	1.8V power domain. If unused, keep this pin open.
GNSS_UART_RXD	28	DI	Receive data	V _{IL} min=-0.3V V _{IL} max=0.6V V _{IH} min=1.2V V _{IH} max=2.0V	1.8V power domain. If unused, keep this pin open.
PCM Interface*					
Pin Name	Pin No.	I/O	Description	DC Characteristics	Comment
PCM_CLK*	4	DO	PCM clock output	V _{OL} max=0.45V V _{OH} min=1.35V	1.8V power domain. If unused, keep this pin open.
PCM_SYNC*	5	DO	PCM frame synchronization output	V _{OL} max=0.45V V _{OH} min=1.35V	1.8V power domain. If unused, keep this pin open.
PCM_IN*	6	DI	PCM data input	V _{IL} min=-0.3V V _{IL} max=0.6V V _{IH} min=1.2V V _{IH} max=2.0V	1.8V power domain. If unused, keep this pin open.
PCM_OUT*	7	DO	PCM data output	V _{OL} max=0.45V V _{OH} min=1.35V	1.8V power domain. If unused, keep this pin open.
I2C Interface*					
Pin Name	Pin No.	I/O	Description	DC Characteristics	Comment
I2C_SCL*	40	OD	I2C serial clock. Used for external codec.		External pull-up resistor is required. 1.8V only. If unused, keep this

					pin open.
I2C_SDA*	41	OD	I2C serial data. Used for external codec.		External pull-up resistor is required. 1.8V only. If unused, keep this pin open.

Antenna Interfaces

Pin Name	Pin No.	I/O	Description	DC Characteristics	Comment
ANT_MAIN	60	IO	Main antenna interface		50Ω impedance
ANT_GNSS	49	AI	GNSS antenna interface		50Ω impedance. If unused, keep this pin open.

GPIO Interfaces

Pin Name	Pin No.	I/O	Description	DC Characteristics	Comment
GPIO16	16	IO	General-purpose input/output interface	V _{OL} max=0.45V V _{OH} min=1.35V V _{IL} min=-0.3V V _{IL} max=0.6V V _{IH} min=1.2V V _{IH} max=2.0V	1.8V power domain. If unused, keep this pin open.
GPIO25	25	IO	General-purpose input/output interface	V _{OL} max=0.45V V _{OH} min=1.35V V _{IL} min=-0.3V V _{IL} max=0.6V V _{IH} min=1.2V V _{IH} max=2.0V	1.8V power domain. If unused, keep this pin open.
GPIO26	26	IO	General-purpose input/output interface	V _{OL} max=0.45V V _{OH} min=1.35V V _{IL} min=-0.3V V _{IL} max=0.6V V _{IH} min=1.2V V _{IH} max=2.0V	1.8V power domain. If unused, keep this pin open.
GPIO64	64	IO	General-purpose input/output interface	V _{OL} max=0.45V V _{OH} min=1.35V V _{IL} min=-0.3V V _{IL} max=0.6V V _{IH} min=1.2V V _{IH} max=2.0V	1.8V power domain. If unused, keep this pin open.

GPIO65	65	DO	General-purpose input/output interface	$V_{OLmax}=0.45V$ $V_{OHmin}=1.35V$ $V_{ILmin}=-0.3V$ $V_{ILmax}=0.6V$ $V_{IHmin}=1.2V$ $V_{IHmax}=2.0V$	1.8V power domain. If unused, keep this pin open.
GPIO66	66	DO	General-purpose input/output interface	$V_{OLmax}=0.45V$ $V_{OHmin}=1.35V$ $V_{ILmin}=-0.3V$ $V_{ILmax}=0.6V$ $V_{IHmin}=1.2V$ $V_{IHmax}=2.0V$	1.8V power domain. If unused, keep this pin open.

ADC Interfaces

Pin Name	Pin No.	I/O	Description	DC Characteristics	Comment
ADC0 ³⁾	24	AI	General purpose analog to digital converter interface	Voltage range: 0.3V to 1.8V	ADC0 and ADC1 cannot be used simultaneously. BG95 supports using of only one ADC interface at a time: either ADC0 or ADC1. Currently only ADC0 is enabled, and ADC1 will be enabled in the next hardware design version
ADC1 ³⁾	2	AI	General purpose analog to digital converter interface	Voltage range: 0.3V to 1.8V	

Other Interface Pins

Pin Name	Pin No.	I/O	Description	DC Characteristics	Comment
PSM_IND* ⁴⁾	1	DO	Power saving mode indicator	$V_{OLmax}=0.45V$ $V_{OHmin}=1.35V$	1.8V power domain. If unused, keep this pin open.
W_DISABLE#*	18	DI	Airplane mode control	$V_{ILmin}=-0.3V$ $V_{ILmax}=0.6V$ $V_{IHmin}=1.2V$ $V_{IHmax}=2.0V$	1.8V power domain. Pulled up by default. When it is in low voltage level, the module can enter into airplane mode. If unused, keep this pin open.

AP_READY*	19	DI	Application processor sleep state detection	V _{IL} min=-0.3V V _{IL} max=0.6V V _{IH} min=1.2V V _{IH} max=2.0V	1.8V power domain. If unused, keep this pin open.
USB_BOOT	75	DI	Force the module to enter into emergency download mode	V _{IL} min=-0.3V V _{IL} max=0.6V V _{IH} min=1.2V V _{IH} max=2.0V	1.8V power domain. If unused, keep this pin open.

RESERVED Pins

Pin Name	Pin No.	I/O	Description	DC Characteristics	Comment
RESERVED	11~14, 51, 56, 57, 63, 76~78, 83~88, 92~99		Reserved		Keep these pins open.

NOTES

- ¹⁾ The output voltage of PWRKEY is 1.5V because of the diode drop in the Qualcomm chipset, and PWRKEY should never be pulled down to GND permanently.
- ²⁾ RESET_N will be supported in the next hardware design version.
- ³⁾ ADC0 and ADC1 cannot be used simultaneously. BG95 supports using of only one ADC interface at a time: either ADC0 or ADC1. Currently only ADC0 is enabled, and ADC1 will be enabled in the next hardware design version.
- ⁴⁾ When PSM is enabled, the function of PSM_IND* pin will be activated after the module is rebooted. When PSM_IND* is in high voltage level, the module is in normal operation state, when it is in low voltage level, the module is in PSM.
- Keep all RESERVED pins and unused pins unconnected.
- "*" means under development.

3.3. Operating Modes

The table below briefly summarizes the various operating modes of BG95.

Table 6: Overview of Operating Modes

Mode	Details
Normal Operation	Connected Network has been connected. In this mode, the power consumption may vary with the network setting and data transfer rate.
	Idle Software is active. The module remains registered on network, and it is ready to send and receive data.
Extended Idle Mode DRX (e-I-DRX)	BG95 module and the network may negotiate over non-access stratum signaling the use of e-I-DRX for reducing power consumption, while being available for mobile terminating data and/or network originated procedures within a certain delay dependent on the DRX cycle value.
Airplane Mode	AT+CFUN=4 or W_DISABLE#* pin can set the module into airplane mode. In this case, RF function will be invalid.
Minimum Functionality Mode	AT+CFUN=0 can set the module into a minimum functionality mode without removing the power supply. In this case, both RF function and (U)SIM card will be invalid.
Sleep Mode*	In this mode, the current consumption of the module will be reduced to a lower level. During this mode, the module can still receive paging message, SMS and TCP/UDP data from the network normally.
Power Saving Mode (PSM)	BG95 module may enter into Power Saving Mode to further reduce its power consumption. PSM is similar to power-off, but the module remains registered on the network and there is no need to re-attach or re-establish PDN connections.
Power OFF Mode	In this mode, the power management unit shuts down the power supply. Software is not active. The serial interfaces are not accessible. But the operating voltage (connected to VBAT_RF and VBAT_BB) remains applied.

NOTES

1. During e-I-DRX, it is recommended to use UART interface for data communication, as the use of USB interface will increase power consumption.
2. "*" means under development.

3.4. Power Saving

3.4.1. Airplane Mode

When the module enters into airplane mode, the RF function does not work, and all AT commands correlative with RF function will be inaccessible. This mode can be set via the following ways.

Hardware:

W_DISABLE#* is pulled up by default. Driving it to low level will let the module enter into airplane mode.

Software:

AT+CFUN=<fun> provides choice of the functionality level, through setting <fun> into 0, 1 or 4.

- **AT+CFUN=0**: Minimum functionality mode. Both (U)SIM and RF functions are disabled.
- **AT+CFUN=1**: Full functionality mode (by default).
- **AT+CFUN=4**: Airplane mode. RF function is disabled.

NOTES

1. Airplane mode control via W_DISABLE#* is disabled in firmware by default. It can be enabled by **AT+QCFG="airplanecontrol"** command which is still under development. Details about the command will be provided in *document [2]*.
2. The execution of **AT+CFUN** command will not affect GNSS function.
3. "*" means under development.

3.4.2. Power Saving Mode (PSM)

BG95 module can enter into PSM for reducing its power consumption. The mode is similar to power-off, but the module remains registered on the network and there is no need to re-attach or re-establish PDN connections. So BG95 in PSM cannot immediately respond users' requests.

When the module wants to use the PSM it shall request an Active Time value during every Attach and TAU procedures. If the network supports PSM and accepts that the module uses PSM, the network confirms usage of PSM by allocating an Active Time value to the module. If the module wants to change the Active Time value, e.g. when the conditions are changed in the module, the module consequently requests the value it wants in the TAU procedure.

If PSM is supported by the network, then it can be enabled via **AT+CPSMS** command.

Either of the following methods will wake up the module from PSM:

- Drive PWRKEY pin to low level will wake up the module.
- When the T3412_Ext timer expires, the module will be woken up automatically.
- The Main UART data will wake up the module and the function is under development.

NOTE

Please refer to *document [2]* for details about **AT+CPSMS** command.

3.4.3. Extended Idle Mode DRX (e-I-DRX)

The module (UE) and the network may negotiate over non-access stratum signalling the use of e-I-DRX for reducing its power consumption, while being available for mobile terminating data and/or network originated procedures within a certain delay dependent on the DRX cycle value.

Applications that want to use e-I-DRX need to consider specific handling of mobile terminating services or data transfers, and in particular they need to consider the delay tolerance of mobile terminated data.

In order to negotiate the use of e-I-DRX, the UE requests e-I-DRX parameters during attach procedure and RAU/TAU procedure. The EPC may reject or accept the UE request for enabling e-I-DRX. In case the EPC accepts e-I-DRX, the EPC based on operator policies and, if available, the e-I-DRX cycle length value in the subscription data from the HSS, may also provide different values of the e-I-DRX parameters than what was requested by the UE. If the EPC accepts the use of e-I-DRX, the UE applies e-I-DRX based on the received e-I-DRX parameters. If the UE does not receive e-I-DRX parameters in the relevant accept message because the EPC rejected its request or because the request was received by EPC not supporting e-I-DRX, the UE shall apply its regular discontinuous reception.

If e-I-DRX is supported by the network, then it can be enabled by **AT+CEDRXS=1** command.

NOTE

Please refer to **document [2]** for details about **AT+CEDRXS** command.

3.4.4. Sleep Mode*

BG95 is able to reduce its current consumption to a lower value during the sleep mode. The following sub-chapters describe the power saving procedure of BG95 module.

3.4.4.1. UART Application

If the host communicates with module via UART interface, the following preconditions can let the module enter into sleep mode.

- Execute **AT+QSCLK=1** command to enable sleep mode.
- Drive DTR to high level.

The following figure shows the connection between the module and the host.

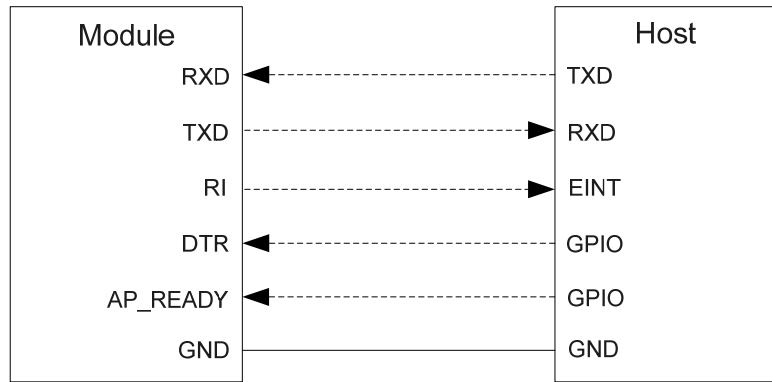

Figure 3: Sleep Mode Application via UART

- When BG95 has URC to report, RI signal will wake up the host. Please refer to **Chapter 3.14** for details about RI behavior.
- Driving the host DTR to low level will wake up the module.
- AP_READY* will detect the sleep state of the host (can be configured to high level or low level detection). Please refer to **AT+QCFG="apready"** command in **document [2]** for details.

NOTE

“*” means under development.

3.5. Power Supply

3.5.1. Power Supply Pins

BG95 provides the following four VBAT pins for connection with an external power supply. There are two separate voltage domains for VBAT.

- Two VBAT_RF pins for module’s RF part.
- Two VBAT_BB pins for module’s baseband part.

The following table shows the details of VBAT pins and ground pins.

Table 7: VBAT and GND Pins

Pin Name	Pin No.	Description	Module	Min.	Typ.	Max.	Unit
VBAT_RF	52, 53	Power supply for the module's RF part	BG95-M1/-M2/-N1	2.4	3.3	4.8	V
			BG95-M3	3.3	3.8	4.3	V
VBAT_BB	32, 33	Power supply for the module's baseband part	BG95-M1/-M2/-N1	2.4	3.3	4.8	V
			BG95-M3	3.3	3.8	4.3	V
GND	3, 31, 48, 50, 54, 55, 58, 59, 61, 62, 67~74, 79~82, 89~91, 100~102	Ground		-	-	-	-

3.5.2. Decrease Voltage Drop

- **BG95-M1/-M2/-N1:** The power supply range of BG95-M1/-M2/-N1 is from 2.4V to 4.8V. Please make sure that the input voltage will never drop below 2.4V.
- **BG95-M3:** The power supply range of the BG95-M3 is from 3.3V to 4.3V. Please make sure that the input voltage will never drop below 3.3V.

The following figure shows the voltage drop during burst transmission in 2G network of BG95-M3 module. The voltage drop will be less in LTE Cat M1 and/or LTE Cat NB2 networks.

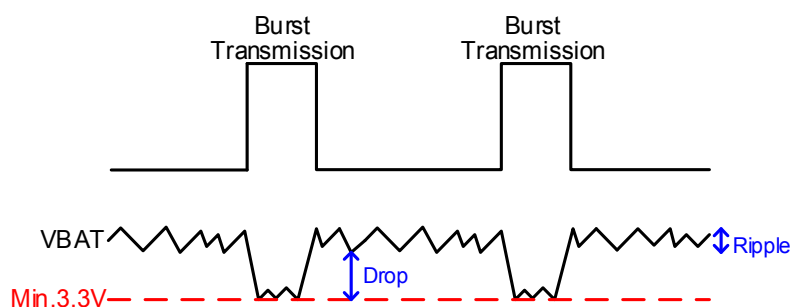

Figure 4: Power Supply Limits during Burst Transmission

To decrease voltage drop, a bypass capacitor of about 100μF with low ESR should be used, and a multi-layer ceramic chip capacitor (MLCC) array should also be reserved due to its low ESR. It is recommended to use three ceramic capacitors (100nF, 33pF, 10pF) for composing the MLCC array, and place these capacitors close to VBAT pins. The main power supply from an external application has to be

a single voltage source and can be expanded to two sub paths with star structure. The width of VBAT_BB trace should be no less than 0.5mm, and the width of VBAT_RF trace should be no less than 2mm. In principle, the longer the VBAT trace is, the wider it will be.

In addition, in order to get a stable power source, it is suggested to use a TVS with low leakage current and suitable reverse stand-off voltage, and also it is recommended to place it as close to the VBAT pins as possible. The following figure shows the star structure of the power supply.

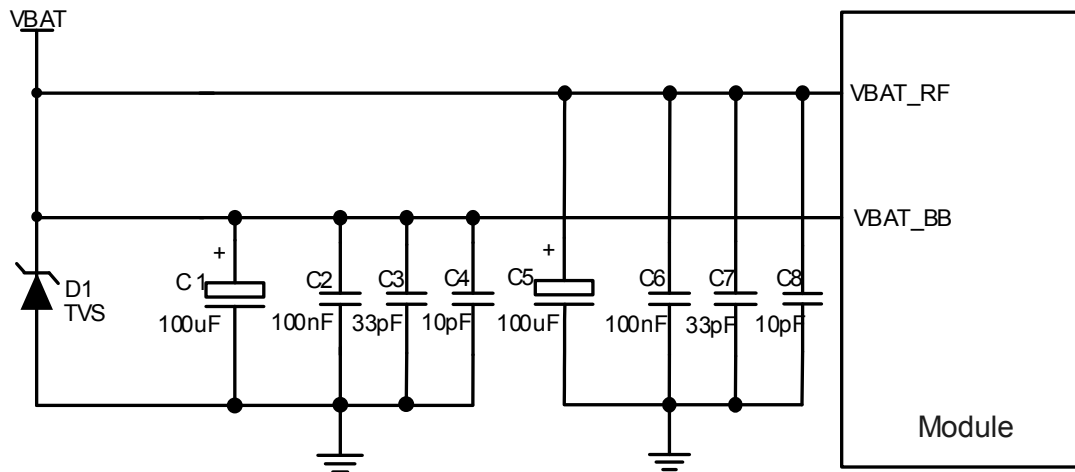

Figure 5: Star Structure of the Power Supply

3.5.3. Monitor the Power Supply

AT+CBC* command can be used to monitor the VBAT_BB voltage value. For more details, please refer to **document [2]**.

NOTE

“*” means under development.

3.6. Turn on and off Scenarios

3.6.1. Turn on Module Using the PWRKEY Pin

The following table shows the pin definition of PWRKEY.

Table 8: Pin Definition of PWRKEY

Pin Name	Pin No.	Description	DC Characteristics	Comment
PWRKEY	15	Turn on/off the module	V _{norm} =1.5V V _{ILmax} =0.45V	The output voltage is 1.5V because of the diode drop in the Qualcomm chipset.

When BG95 is in power off mode, it can be turned on to normal mode by driving the PWRKEY pin to a low level for a duration between 500ms and 1000ms. It is recommended to use an open drain/collector driver to control the PWRKEY. A simple reference circuit is illustrated in the following figure.

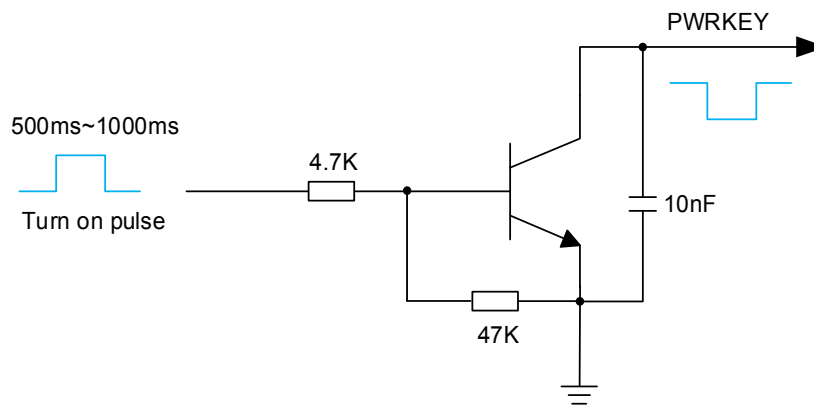

Figure 6: Turn on the Module Using Driving Circuit

Another way to control the PWRKEY is using a button directly. When pressing the key, electrostatic strike may generate from the finger. Therefore, a TVS component is indispensable to be placed nearby the button for ESD protection. A reference circuit is shown in the following figure.

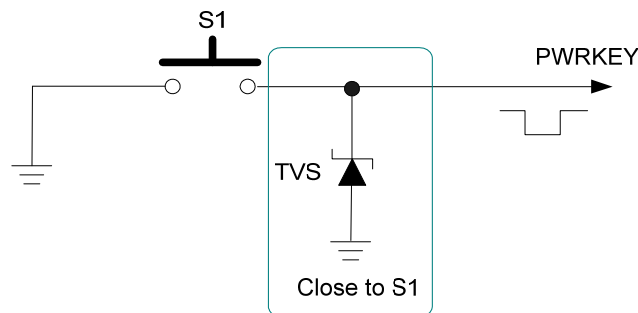

Figure 7: Turn on the Module Using Keystroke

The turn on scenario is illustrated in the following figure.

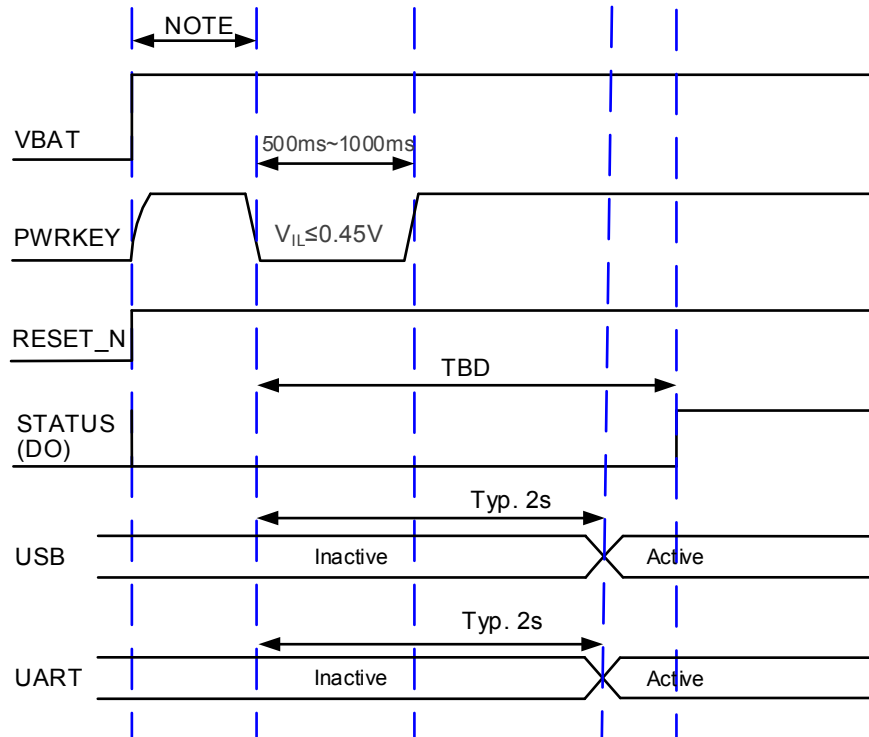

Figure 8: Timing of Turning on Module

NOTES

1. Make sure that VBAT is stable before pulling down PWRKEY pin. The time between them is no less than 30ms.
2. PWRKEY is internally pulled up to an internal voltage in the Qualcomm chipset, and its output voltage is the internal voltage minus a diode drop in the chipset. Therefore, the expected output voltage of PWRKEY is 1.5V.
3. PWRKEY should never be pulled down to GND permanently.

3.6.2. Turn off Module

Either of the following methods can be used to turn off the module:

- Normal power down procedure: Turn off the module using the PWRKEY pin.
- Normal power down procedure: Turn off the module using **AT+QPOWD** command.

3.6.2.1. Turn off Module Using the PWRKEY Pin

Driving the PWRKEY pin to a low level voltage for a duration between 650ms and 1500ms, the module will execute power-down procedure after the PWRKEY is released.

The power-down scenario is illustrated in the following figure.

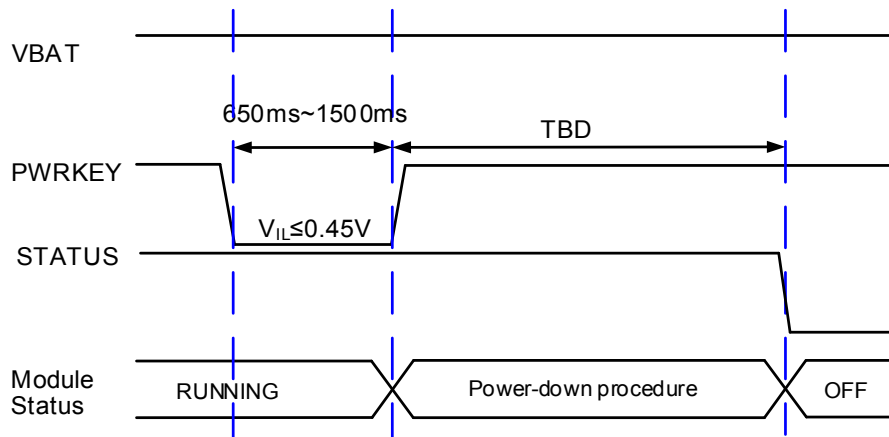

Figure 9: Timing of Turning off Module

3.6.2.2. Turn off Module Using AT Command

It is also a safe way to use **AT+QPOWD** command to turn off the module, which is similar to turning off the module via PWRKEY pin.

Please refer to **document [2]** for details about **AT+QPOWD** command.

3.7. Reset the Module

RESET_N is used to reset the module and will be supported in the next hardware design version. The module can be reset by driving RESET_N to a low level voltage for a duration between 2s and 3.8s.

Table 9: Pin Definition of RESET_N

Pin Name	Pin No.	Description	DC Characteristics	Comment
RESET_N	17	Reset the module	$V_{ILmax}=0.45V$	RESET_N will be supported in the next hardware design version.

The reset scenario is illustrated in the following figure.

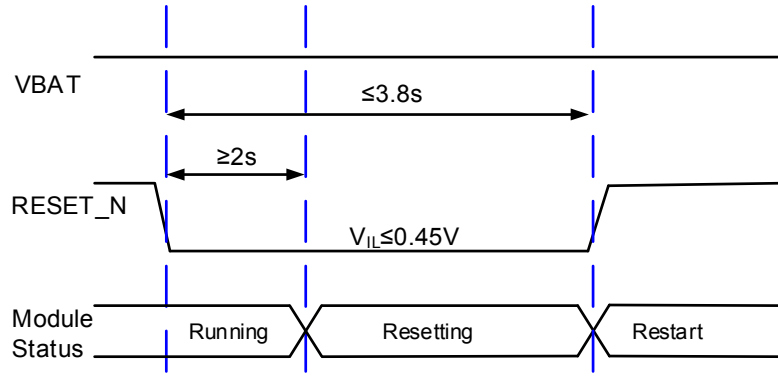

Figure 10: Timing of Reset Module

The recommended circuit is similar to the PWRKEY control circuit. An open drain/collector driver or button can be used to control the RESET_N pin.

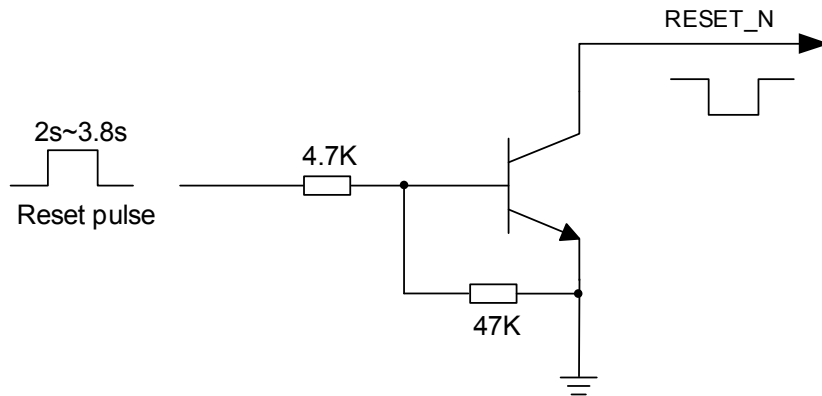

Figure 11: Reference Circuit of RESET_N by Using Driving Circuit

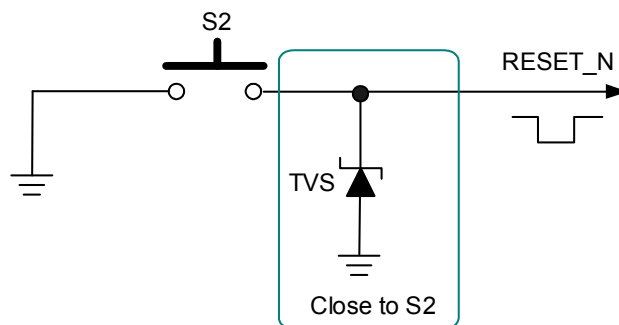

Figure 12: Reference Circuit of RESET_N by Using Button

NOTE

Please assure that there is no large capacitance on RESET_N pin.

3.8. (U)SIM Interface

The (U)SIM interface circuitry meets ETSI and IMT-2000 requirements. BG95 supports 1.8V (U)SIM card only.

Table 10: Pin Definition of (U)SIM Interface

Pin Name	Pin No.	I/O	Description	Comment
USIM_PRESENCE*	42	DI	(U)SIM card insertion detection	
USIM_VDD	43	PO	Power supply for (U)SIM card	Only 1.8V (U)SIM card is supported.
USIM_RST	44	DO	Reset signal of (U)SIM card	
USIM_DATA	45	IO	Data signal of (U)SIM card	
USIM_CLK	46	DO	Clock signal of (U)SIM card	
USIM_GND	47		Specified ground for (U)SIM card	

BG95 supports (U)SIM card hot-plug via the USIM_PRESENCE* pin. The function supports low level and high level detections, and is disabled by default. Please refer to **document [2]** about **AT+QSIMDET*** command for details.

The following figure shows a reference design of (U)SIM interface with an 8-pin (U)SIM card connector.

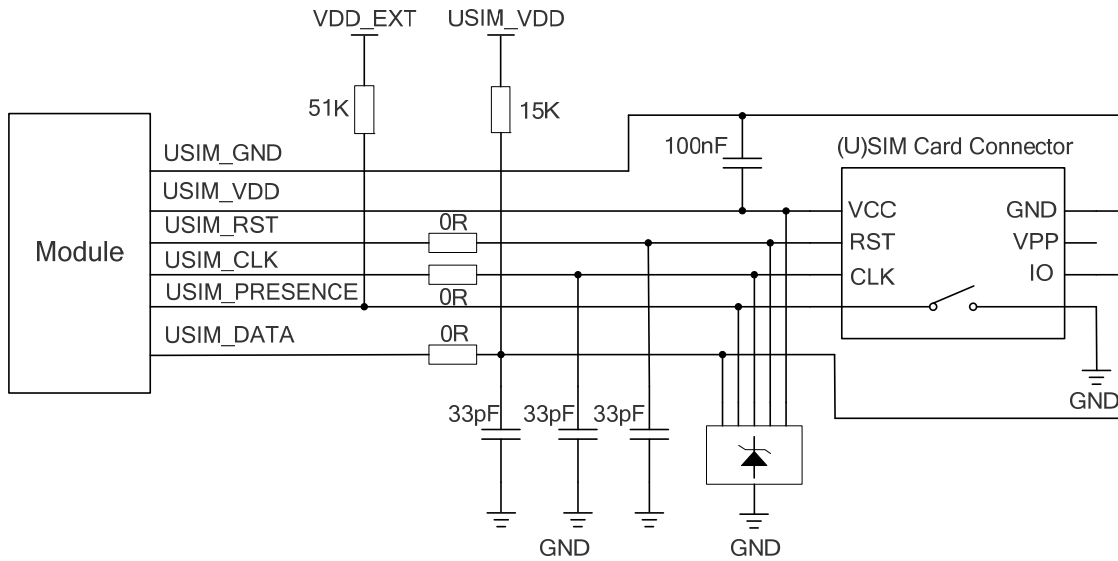

Figure 13: Reference Circuit of (U)SIM Interface with an 8-Pin (U)SIM Card Connector

If (U)SIM card detection function is not needed, please keep USIM_PRESENCE* unconnected. A reference circuit for (U)SIM interface with a 6-pin (U)SIM card connector is illustrated in the following figure.

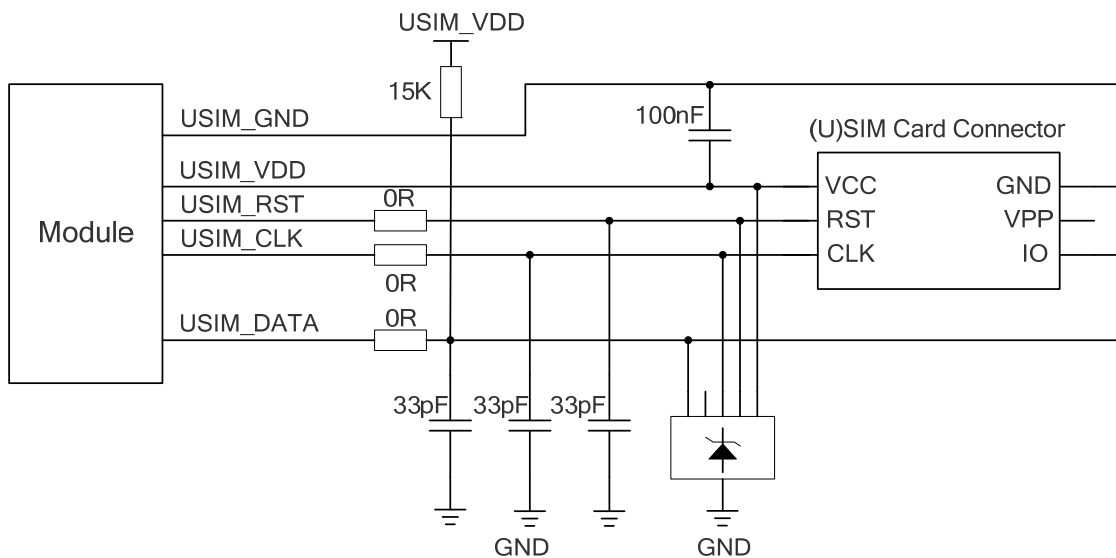

Figure 14: Reference Circuit of (U)SIM Interface with a 6-Pin (U)SIM Card Connector

In order to enhance the reliability and availability of the (U)SIM card in applications, please follow the criteria below in (U)SIM circuit design:

- Keep the placement of (U)SIM card connector as close to the module as possible. Keep the trace length as less than 200mm as possible.
- Keep (U)SIM card signals away from RF and VBAT traces.

- Assure the ground between the module and the (U)SIM card connector short and wide. Keep the trace width of ground and USIM_VDD no less than 0.5mm to maintain the same electric potential. Make sure the bypass capacitor between USIM_VDD and USIM_GND less than 1uF, and place it as close to (U)SIM card connector as possible. If the system ground plane is complete, USIM_GND can be connected to the system ground directly.
- To avoid cross-talk between USIM_DATA and USIM_CLK, keep them away from each other and shield them with surrounded ground. USIM_RST should also be ground shielded.
- In order to offer good ESD protection, it is recommended to add a TVS diode array with parasitic capacitance not exceeding 15pF. In order to facilitate debugging, it is recommended to reserve series resistors for the (U)SIM signals of the module. The 33pF capacitors are used for filtering interference of GSM 900MHz. Please note that the (U)SIM peripheral circuit should be close to the (U)SIM card connector.
- The pull-up resistor on USIM_DATA line can improve anti-jamming capability when long layout trace and sensitive occasion are applied, and should be placed close to the (U)SIM card connector.

NOTE

“*” means under development.

3.9. USB Interface

BG95 contains one integrated Universal Serial Bus (USB) interface which complies with the USB 2.0 specification and supports low-speed (1.5Mbps) and full-speed (12Mbps) modes. The USB interface is used for AT command communication, data transmission, software debugging and firmware upgrade. The following table shows the pin definition of USB interface.

Table 11: Pin Definition of USB Interface

Pin Name	Pin No.	I/O	Description	Comment
USB_VBUS	8	PI	USB connection detection	Typically 5.0V
USB_DP	9	IO	USB differential data bus (+)	Require differential impedance of 90Ω
USB_DM	10	IO	USB differential data bus (-)	
GND	3		Ground	

For more details about USB 2.0 specification, please visit <http://www.usb.org/home>.

The USB interface is recommended to be reserved for firmware upgrade in customers' designs. The following figure shows a reference circuit of USB interface.

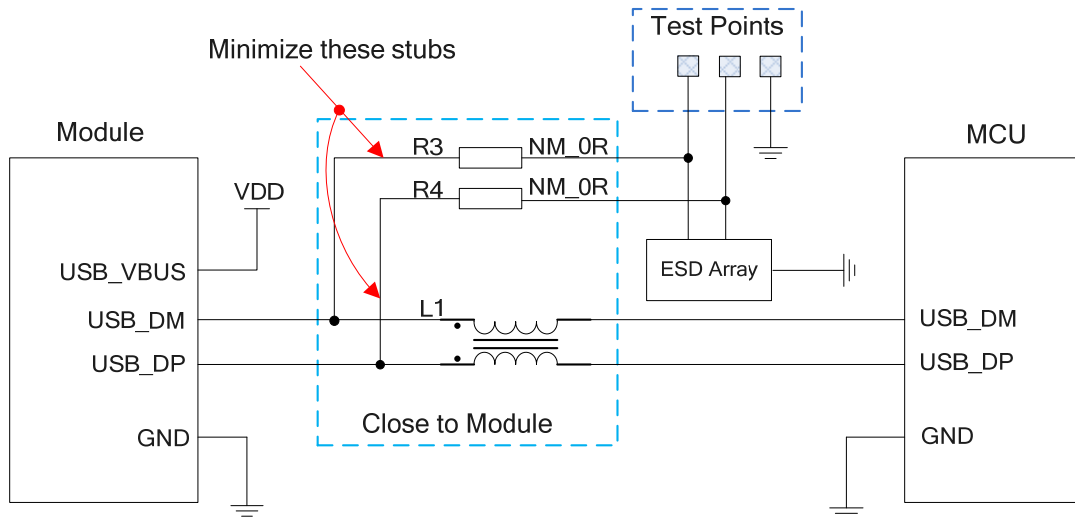

Figure 15: Reference Circuit of USB Interface

A common mode choke L1 is recommended to be added in series between the module and customer's MCU in order to suppress EMI spurious transmission. Meanwhile, the 0Ω resistors (R3 and R4) should be added in series between the module and the test points so as to facilitate debugging, and the resistors are not mounted by default. In order to ensure the integrity of USB data line signal, L1/R3/R4 components must be placed close to the module, and also these resistors should be placed close to each other. The extra stubs of trace must be as short as possible.

The following principles should be complied with when design the USB interface, so as to meet USB 2.0 specification.

- It is important to route the USB signal traces as differential pairs with total grounding. The impedance of USB differential trace is 90Ω.
- Do not route signal traces under crystals, oscillators, magnetic devices and RF signal traces. It is important to route the USB differential traces in inner-layer with ground shielding on not only upper and lower layers but also right and left sides.
- Pay attention to the influence of junction capacitance of ESD protection components on USB data lines. Typically, the capacitance value should be less than 2pF.
- Keep the ESD protection components as close to the USB connector as possible.

NOTE

BG95 module can only be used as a slave device.

3.10. UART Interfaces

The module provides three UART interfaces: Main UART, Debug UART and GNSS UART interfaces. Features of them are illustrated below:

- The Main UART interface supports 9600bps, 19200bps, 38400bps, 57600bps, 115200bps, 230400bps, 460800bps and 921600bps baud rates, and the default is 115200bps. It is used for data transmission and AT command communication, and supports RTS and CTS hardware flow control. The default frame format is 8N1 (8 data bits, no parity, 1 stop bit).
- The Debug UART interface supports a fixed baud rate of 115200bps, and is used for software debugging and log output.
- The GNSS UART interface supports 115200bps baud rate by default, and is used for GNSS data and NMEA sentences output.

The following tables show the pin definition of the three UART interfaces.

Table 12: Pin Definition of Main UART Interface

Pin Name	Pin No.	I/O	Description	Comment
DTR	30	DI	Data terminal ready. Sleep mode control	1.8V power domain
RXD	34	DI	Receive data	1.8V power domain
TXD	35	DO	Transmit data	1.8V power domain
CTS	36	DO	Clear to send	1.8V power domain
RTS	37	DI	Request to send	1.8V power domain
DCD	38	DO	Data carrier detection	1.8V power domain
RI	39	DO	Ring indication signal	1.8V power domain

NOTE

AT+IPR command can be used to set the baud rate of the Main UART interface, and **AT+IFC** command can be used to set the hardware flow control (hardware flow control is disabled by default). Please refer to **document [2]** for more details about these AT commands.

Table 13: Pin Definition of Debug UART Interface

Pin Name	Pin No.	I/O	Description	Comment
DBG_RXD	22	DI	Receive data	1.8V power domain
DBG_TXD	23	DO	Transmit data	1.8V power domain

Table 14: Pin Definition of GNSS UART Interface

Pin Name	Pin No.	I/O	Description	Comment
GNSS_UART_TXD	27	DO	Transmit data	1.8V power domain
GNSS_UART_RXD	28	DI	Receive data	1.8V power domain

The logic levels of UART interfaces are described in the following table.

Table 15: Logic Levels of Digital I/O

Parameter	Min.	Max.	Unit
V_{IL}	-0.3	0.6	V
V_{IH}	1.2	2.0	V
V_{OL}	0	0.45	V
V_{OH}	1.35	1.8	V

The module provides 1.8V UART interface. A level translator should be used if customers' application is equipped with a 3.3V UART interface. A level translator TXS0108EPWR provided by *Texas Instruments* is recommended. The following figure shows a reference design of the Main UART interface:

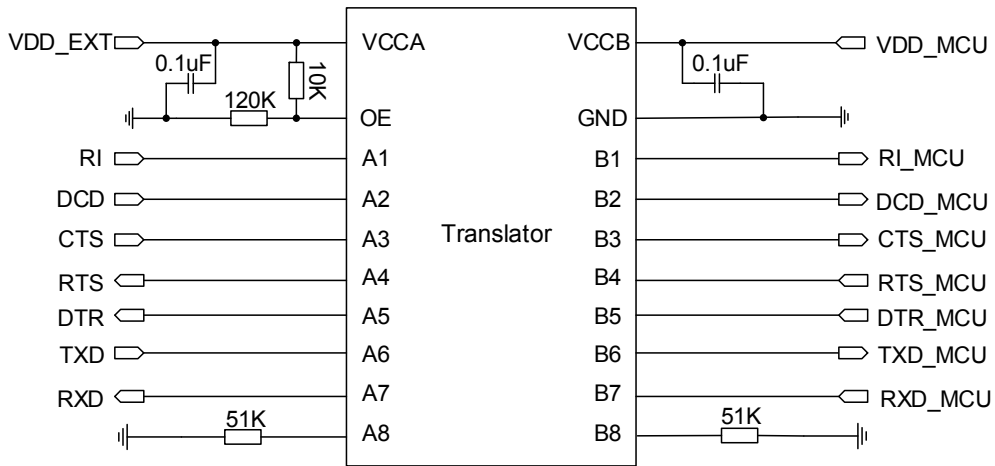

Figure 16: Reference Circuit with Translator Chip

Please visit <http://www.ti.com> for more information.

Another example with transistor translation circuit is shown as below. The circuit design of dotted line section can refer to that of solid line section, in terms of both module input and output circuit designs, but please pay attention to the direction of connection.

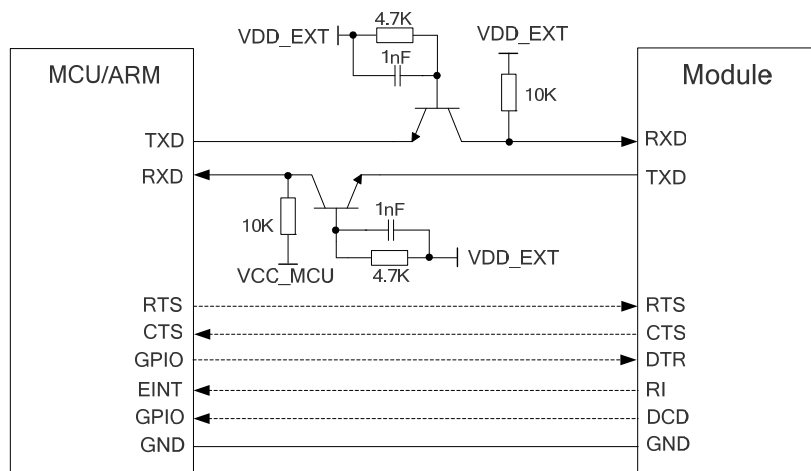

Figure 17: Reference Circuit with Transistor Circuit

NOTE

Transistor circuit solution is not suitable for applications with high baud rates exceeding 460Kbps.

3.11. PCM* and I2C* Interfaces

BG95 provides one Pulse Code Modulation (PCM) digital interface and one I2C interface. The following table shows the pin definition of the two interfaces which can be applied on audio codec design.

Table 16: Pin Definition of PCM and I2C Interfaces

Pin Name	Pin No.	I/O	Description	Comment
PCM_CLK*	4	DO	PCM clock output	1.8V power domain
PCM_SYNC*	5	DO	PCM frame synchronization output	1.8V power domain
PCM_IN*	6	DI	PCM data input	1.8V power domain
PCM_OUT*	7	DO	PCM data output	1.8V power domain
I2C_SCL*	40	OD	I2C serial clock	Require external pull-up to 1.8V
I2C_SDA*	41	OD	I2C serial data	Require external pull-up to 1.8V

The following figure shows a reference design of PCM and I2C interfaces with an external codec IC.

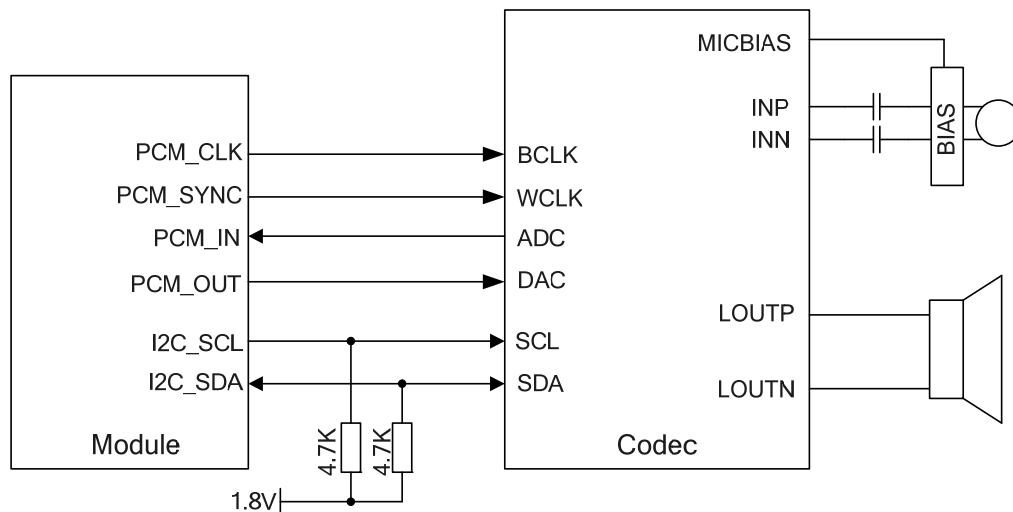

Figure 18: Reference Circuit of PCM Application with Audio Codec

NOTE

“*” means under development.

3.12. Network Status Indication

BG95 provides one network status indication pin: NETLIGHT. The pin is used to drive a network status indication LED. The following tables describe the pin definition and logic level changes of NETLIGHT in different network activity status.

Table 17: Pin Definition of NETLIGHT

Pin Name	Pin No.	I/O	Description	Comment
NETLIGHT	21	DO	Indicate the module's network activity status	1.8V power domain

Table 18: Working State of NETLIGHT

Pin Name	Logic Level Changes	Network Status
NETLIGHT	Flicker slowly (200ms High/1800ms Low)	Network searching
	Flicker slowly (1800ms High/200ms Low)	Idle
	Flicker quickly (125ms High/125ms Low)	Data transfer is ongoing
	Always high	Voice calling

A reference circuit is shown in the following figure.

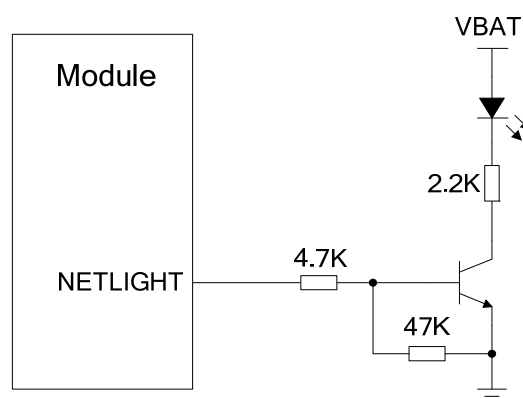

Figure 19: Reference Circuit of the Network Status Indicator

3.13. STATUS

The STATUS pin is used to indicate the operation status of BG95 module. It will output high level when the module is powered on.

The following table describes the pin definition of STATUS.

Table 19: Pin Definition of STATUS

Pin Name	Pin No.	I/O	Description	Comment
STATUS	20	DO	Indicate the module's operation status	1.8V power domain

The following figure shows a reference circuit of STATUS.

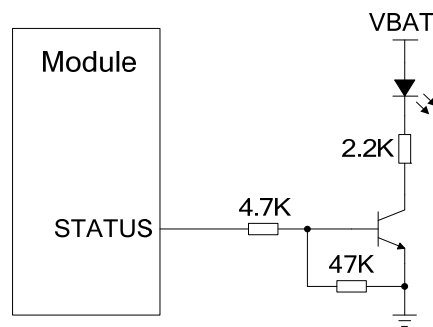

Figure 20: Reference Circuit of STATUS

3.14. Behaviors of RI*

`AT+QCFG="risignalttype","physical"` command can be used to configure RI behavior.

No matter on which port URC is presented, URC will trigger the behavior of RI pin.

The default behaviors of RI are shown as below.

Table 20: Default Behaviors of RI

State	Response
Idle	RI keeps in high level.
URC	RI outputs 120ms low pulse when new URC returns.

The default RI behaviors can be configured flexibly by **AT+QCFG="urc/ri/ring"** command. For more details about **AT+QCFG***, please refer to *document [2]*.

NOTES

1. URC can be outputted from UART port, USB AT port and USB modem port, through configuration via **AT+QURCCFG** command. The default port is USB AT port.
2. "*" means under development.

3.15. USB_BOOT Interface

BG95 provides a USB_BOOT pin. During development or factory production, USB_BOOT can force the module to boot from USB port for firmware upgrade.

Table 21: Pin Definition of USB_BOOT Interface

Pin Name	Pin No.	I/O	Description	Comment
USB_BOOT	75	DI	Force the module to enter into emergency download mode	1.8V power domain. Active high. If unused, keep it open.

The following figure shows a reference circuit of USB_BOOT interface.

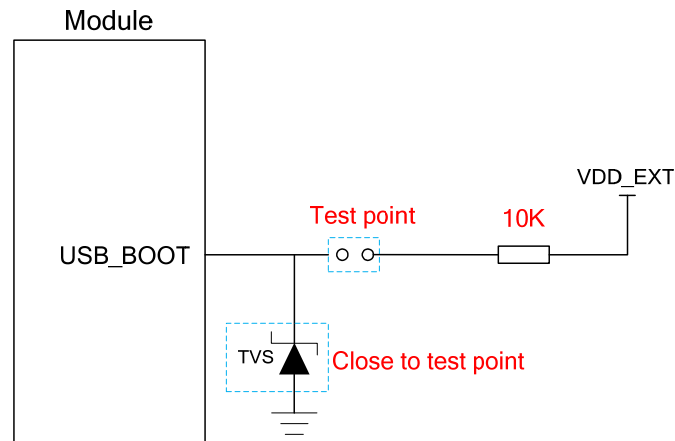

Figure 21: Reference Circuit of USB_BOOT Interface

NOTE

It is recommended to reserve the above circuit design during application design.

3.16. ADC Interfaces

The module provides two analog-to-digital converter (ADC) interfaces but only one ADC interface can be used for each time. **AT+QADC=0** command can be used to read the voltage value on the ADC being used. For more details about the AT command, please refer to **document [2]**.

In order to improve the accuracy of ADC voltage values, the trace of ADC should be surrounded by ground.

Table 22: Pin Definition of ADC Interface

Pin Name	Pin No.	Description
ADC0	24	ADC0 and ADC1 cannot be used simultaneously. Currently only ADC0 is enabled, and ADC1 will be enabled in the next hardware design version.
ADC1	2	

The following table describes the characteristics of ADC interfaces.

Table 23: Characteristics of ADC Interfaces

Parameter	Min.	Typ.	Max.	Unit
ADC0/ADC1 Voltage Range	0.3		1.8	V
ADC0/ADC1 Resolution		64.979		uV
ADC0/ADC1 Sampling Rate		4.8		MHz

NOTES

1. ADC0 and ADC1 cannot be used simultaneously. BG95 supports using of only one ADC interface at a time: either ADC0 or ADC1. Currently only ADC0 is enabled, and ADC1 will be enabled in the next hardware design version.
2. ADC input voltage must not exceed 1.8V.
3. It is prohibited to supply any voltage to ADC pin when VBAT is removed.
4. It is recommended to use resistor divider circuit for ADC application, and the divider resistor accuracy should be no less than 1%.

3.17. GPIO Interfaces

The module provides six general-purpose input and output (GPIO) interfaces. **AT+QCFG="gpio"** command can be used to configure corresponding GPIO pin's status. For more details about the AT command, please refer to **document [2]**.

Table 24: Pin Definition of GPIO Interfaces

Pin Name	Pin No.	Description
GPIO16	16	General-purpose input and output interface
GPIO25	25	General-purpose input and output interface
GPIO26	26	General purpose input and output interface
GPIO64	64	General purpose input and output interface
GPIO65	65	General purpose input and output interface
GPIO66	66	General purpose input and output interface

The following table describes the characteristics of GPIO interfaces.

Table 25: Logic Levels of GPIO Interfaces

Parameter	Min.	Max.	Unit
V_{IL}	-0.3	0.6	V
V_{IH}	1.2	2.0	V
V_{OL}	0	0.45	V
V_{OH}	1.35	1.8	V

NOTE

“*” means under development.

4 GNSS Receiver

4.1. General Description

BG95 includes a fully integrated global navigation satellite system solution that supports Gen9 VT of Qualcomm (GPS, GLONASS, BeiDou and Galileo).

BG95 supports standard NMEA-0183 protocol, and outputs NMEA sentences at 1Hz data update rate via USB interface by default.

By default, BG95 GNSS engine is switched off. It has to be switched on via AT command. For more details about GNSS engine technology and configurations, please refer to **document [3]**.

4.2. GNSS Performance

The following table shows the GNSS performance of BG95.

Table 26: GNSS Performance

Parameter	Description	Conditions	Typ.	Unit
Sensitivity (GNSS)	Cold start	Autonomous	TBD	dBm
	Reacquisition	Autonomous	TBD	dBm
	Tracking	Autonomous	TBD	dBm
TTFF (GNSS)	Cold start	Autonomous	TBD	s
	@open sky	XTRA enabled	TBD	s
	Warm start	Autonomous	TBD	s
	@open sky	XTRA enabled	TBD	s

	Hot start @open sky	Autonomous	TBD	s
		XTRA enabled	TBD	s
Accuracy (GNSS)	CEP-50	Autonomous @open sky	TBD	m

NOTES

1. Tracking sensitivity: the lowest GNSS signal value at the antenna port on which the module can keep on positioning for 3 minutes.
2. Reacquisition sensitivity: the lowest GNSS signal value at the antenna port on which the module can fix position again within 3 minutes after loss of lock.
3. Cold start sensitivity: the lowest GNSS signal value at the antenna port on which the module fixes position within 3 minutes after executing cold start command.

4.3. Layout Guidelines

The following layout guidelines should be taken into account in customers designs.

- Maximize the distance between GNSS antenna and main antenna.
- Digital circuits such as (U)SIM card, USB interface, camera module, display connector and SD card should be kept away from the antennas.
- Use ground vias around the GNSS trace and sensitive analog signal traces to provide coplanar isolation and protection.
- Keep 50Ω characteristic impedance for the ANT_GNSS trace.

Please refer to **Chapter 5** for GNSS antenna reference design and antenna installation information.

5 Antenna Interfaces

BG95 includes a main antenna interface and a GNSS antenna interface. The antenna ports have an impedance of 50Ω.

5.1. Main Antenna Interface

5.1.1. Pin Definition

The pin definition of main antenna interface is shown below.

Table 27: Pin Definition of Main Antenna Interface

Pin Name	Pin No.	I/O	Description	Comment
ANT_MAIN	60	IO	Main antenna interface	50Ω characteristic impedance

5.1.2. Operating Frequency

Table 28: BG95 Operating Frequency

3GPP Band	Transmit	Receive	Unit
LTE-FDD B1	1920~1980	2110~2170	MHz
LTE-FDD B2, PCS1900	1850~1910	1930~1990	MHz
LTE-FDD B3, DCS1800	1710~1785	1805~1880	MHz
LTE-FDD B4	1710~1755	2110~2155	MHz
LTE-FDD B5, GSM850	824~849	869~894	MHz
LTE-FDD B8, EGSM900	880~915	925~960	MHz
LTE-FDD B12	699~716	729~746	MHz

LTE-FDD B13	777~787	746~756	MHz
LTE-FDD B14 ¹⁾	788~798	758~768	MHz
LTE-FDD B18	815~830	860~875	MHz
LTE-FDD B19	830~845	875~890	MHz
LTE-FDD B20	832~862	791~821	MHz
LTE-FDD B25	1850~1915	1930~1995	MHz
LTE-FDD B26*	814~849	859~894	MHz
LTE-FDD B27 ¹⁾	807~824	852~869	MHz
LTE-FDD B28	703~748	758~803	MHz
LTE-TDD B66	1710~1780	2110~2200	MHz
LTE-TDD B71 ²⁾	663~698	617~652	MHz
LTE-TDD B85	698~716	728~746	MHz

NOTES

- ¹⁾ LTE-FDD B14 and B27 are supported by Cat M1 only.
- ²⁾ LTE-FDD B71 is supported by Cat NB2 only.
- “*” means under development.

5.1.3. Reference Design of RF Antenna Interface

A reference design of main antenna pad is shown as below. A π -type matching circuit should be reserved for better RF performance, and the π -type matching components (R1/C1/C2) should be placed as close to the antenna as possible. The capacitors are not mounted by default.

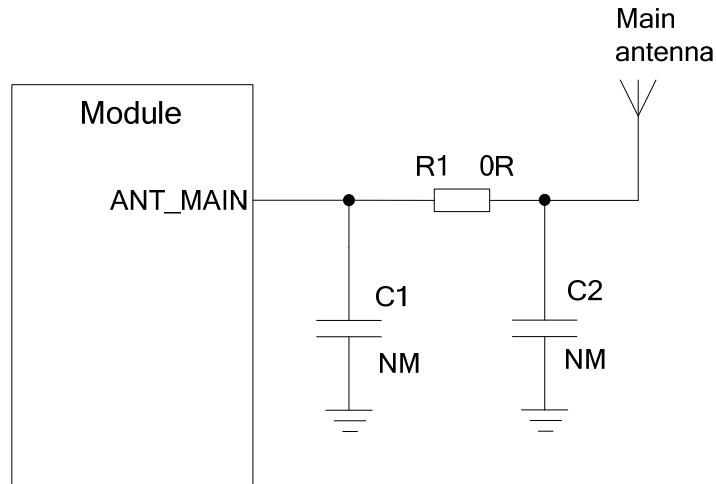

Figure 22: Reference Circuit of RF Antenna Interface

5.1.4. Reference Design of RF Layout

For user's PCB, the characteristic impedance of all RF traces should be controlled as 50Ω. The impedance of the RF traces is usually determined by the trace width (W), the materials' dielectric constant, the distance between signal layer and reference ground (H), and the clearance between RF trace and ground (S). Microstrip line or coplanar waveguide line is typically used in RF layout for characteristic impedance control. The following are reference designs of microstrip line or coplanar waveguide line with different PCB structures.

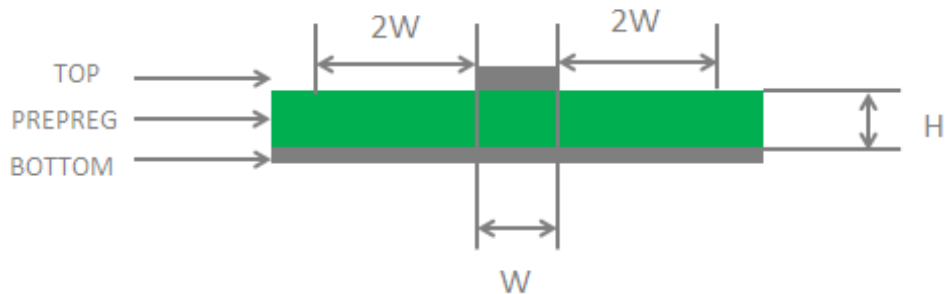

Figure 23: Microstrip Line Design on a 2-layer PCB

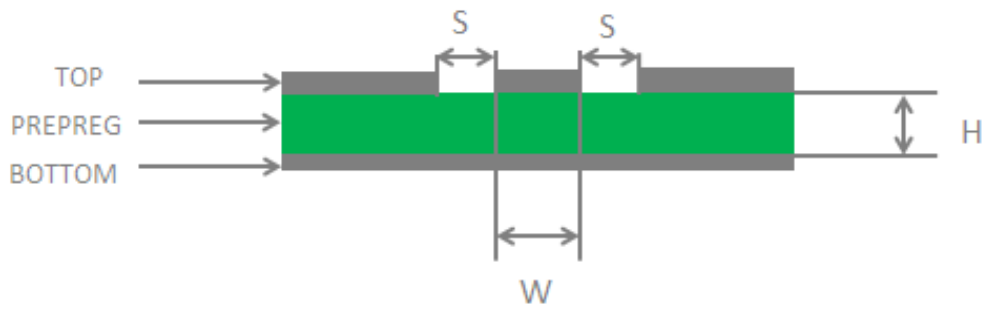

Figure 24: Coplanar Waveguide Line Design on a 2-layer PCB

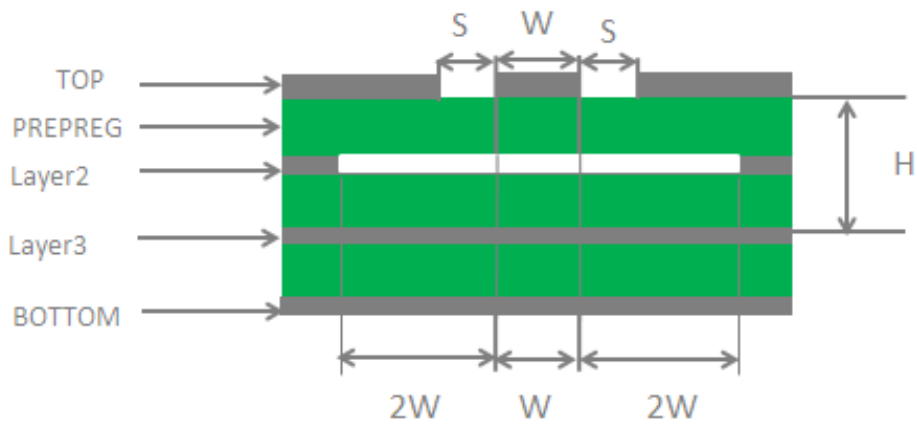

Figure 25: Coplanar Waveguide Line Design on a 4-layer PCB (Layer 3 as Reference Ground)

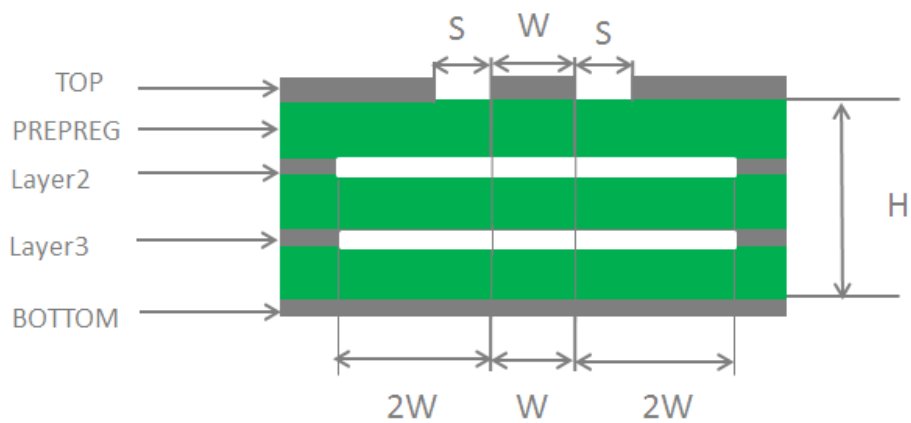

Figure 26: Coplanar Waveguide Line Design on a 4-layer PCB (Layer 4 as Reference Ground)

In order to ensure RF performance and reliability, the following principles should be complied with in RF layout design:

- Use impedance simulation tool to control the characteristic impedance of RF traces as 50Ω.
- The GND pins adjacent to RF pins should not be designed as thermal relief pads, and should be fully connected to ground.
- The distance between the RF pins and the RF connector should be as short as possible, and all the right angle traces should be changed to curved ones.
- There should be clearance area under the signal pin of the antenna connector or solder joint.
- The reference ground of RF traces should be complete. Meanwhile, adding some ground vias around RF traces and the reference ground could help to improve RF performance. The distance between the ground vias and RF traces should be no less than two times the width of RF signal traces (2*W).

For more details about RF layout, please refer to **document [4]**.

5.2. GNSS Antenna Interface

The following tables show the pin definition and frequency specification of GNSS antenna interface.

Table 29: Pin Definition of GNSS Antenna Interface

Pin Name	Pin No.	I/O	Description	Comment
ANT_GNSS	49	AI	GNSS antenna interface	50Ω impedance

Table 30: GNSS Frequency

Type	Frequency	Unit
GPS	1575.42±1.023	MHz
GLONASS	1597.5~1605.8	MHz
Galileo	1575.42±2.046	MHz
BeiDou	1561.098±2.046	MHz

A reference design of GNSS antenna interface is shown as below.

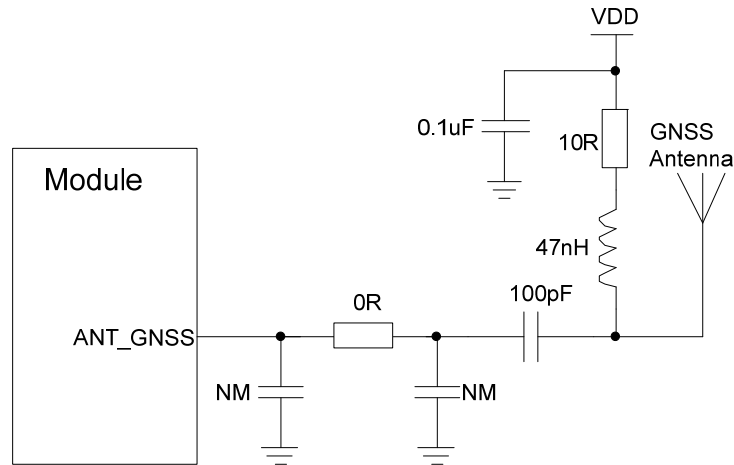

Figure 27: Reference Circuit of GNSS Antenna Interface

NOTES

1. An external LDO can be selected to supply power according to the active antenna requirement.
2. If the module is designed with a passive antenna, then the VDD circuit is not needed.

5.3. Antenna Installation

5.3.1. Antenna Requirements

The following table shows the requirements on main antenna and GNSS antenna.

Table 31: Antenna Requirements

Antenna Type	Requirements
GNSS ¹⁾	Frequency range: 1559MHz ~1609MHz Polarization: RHCP or linear VSWR: < 2 (Typ.) Passive antenna gain: > 0dBi Active antenna noise figure: < 1.5dB Active antenna gain: > 0dBi Active antenna embedded LNA gain: < 17dB
LTE/GSM	VSWR: ≤ 2 Efficiency: > 30% Max Input Power (W): 50 Input Impedance (Ω): 50

Cable Insertion Loss: < 1dB
(LTE B5/B8/B12/B13/B14²⁾/B18/B19/B20/B26*/B27²⁾/B28/B71³⁾/ B85,
GSM850/EGSM900)

Cable Insertion Loss: < 1.5dB
(LTE B1/B2/B3/B4/B25/B66, DCS1800/PCS1900)

NOTES

1. ¹⁾ It is recommended to use a passive GNSS antenna when LTE B13 or B14 is supported, as the use of active antenna may generate harmonics which will affect the GNSS performance.
2. ²⁾ LTE-FDD B14 and B27 are supported by Cat M1 only.
3. ³⁾ LTE-FDD B71 is supported by Cat NB2 only.
4. "*" means under development.

5.3.2. Recommended RF Connector for Antenna Installation

If RF connector is used for antenna connection, it is recommended to use the U.FL-R-SMT connector provided by *HIROSE*.

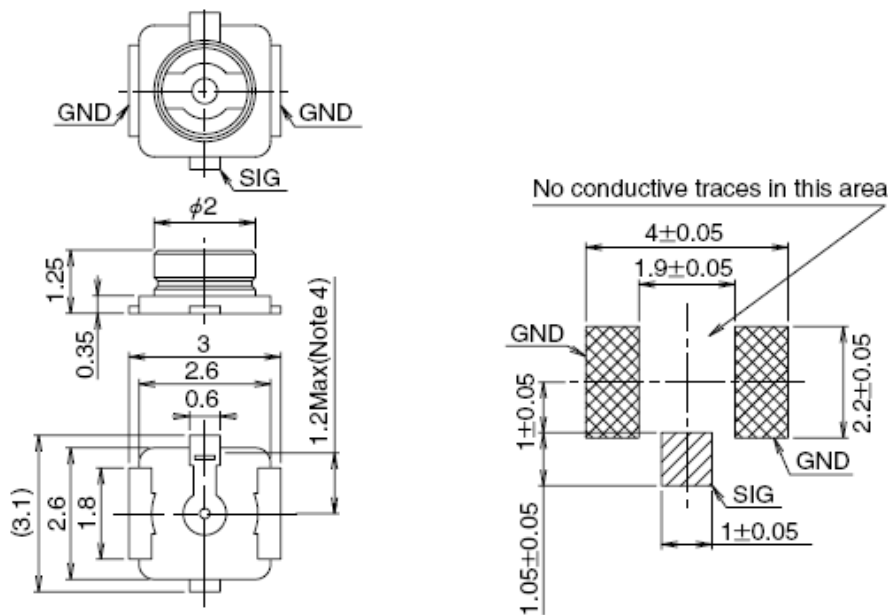

Figure 28: Dimensions of the U.FL-R-SMT Connector (Unit: mm)

U.FL-LP serial connectors listed in the following figure can be used to match the U.FL-R-SMT.

Part No.	U.FL-LP-040	U.FL-LP-066	U.FL-LP(V)-040	U.FL-LP-062	U.FL-LP-088
Mated Height	2.5mm Max. (2.4mm Nom.)	2.5mm Max. (2.4mm Nom.)	2.0mm Max. (1.9mm Nom.)	2.4mm Max. (2.3mm Nom.)	2.4mm Max. (2.3mm Nom.)
Applicable cable	Dia. 0.81mm Coaxial cable	Dia. 1.13mm and Dia. 1.32mm Coaxial cable	Dia. 0.81mm Coaxial cable	Dia. 1mm Coaxial cable	Dia. 1.37mm Coaxial cable
Weight (mg)	53.7	59.1	34.8	45.5	71.7
RoHS	YES				

Figure 29: Mechanicals of U.FL-LP Connectors

The following figure describes the space factor of mated connector.

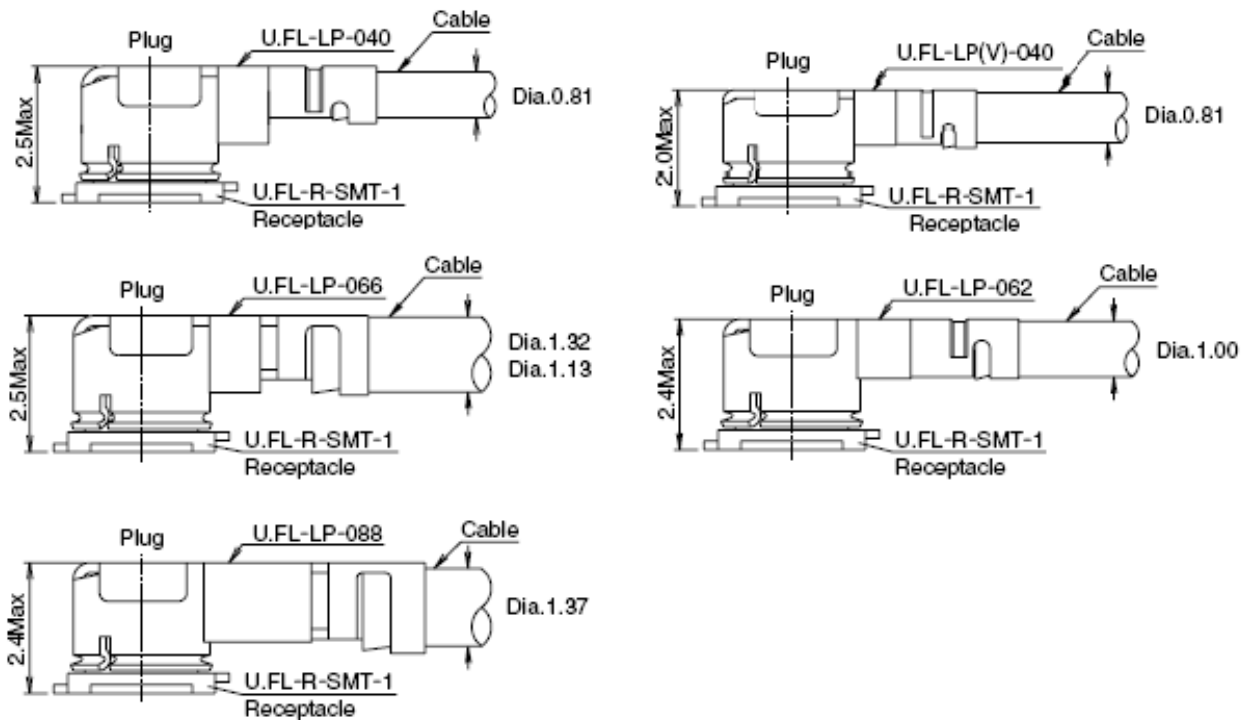

Figure 30: Space Factor of Mated Connector (Unit: mm)

For more details, please visit <http://www.hirose.com>.

6 Electrical, Reliability and Radio Characteristics

6.1. Absolute Maximum Ratings

Absolute maximum ratings for power supply and voltage on digital and analog pins of the module are listed in the following table.

Table 32: Absolute Maximum Ratings

Parameter	Min.	Max.	Unit
VBAT_BB	-0.5	6.0	V
VBAT_RF	-0.3	6.0	V
USB_VBUS	-0.3	5.5	V
Voltage at Digital Pins	-0.3	2.3	V

6.2. Power Supply Ratings

Table 33: Power Supply Ratings

Parameter	Description	Conditions	Module	Min.	Typ.	Max.	Unit
VBAT	VBAT_BB/ VBAT_RF	The actual input voltages must stay between the minimum and maximum values.	BG95-M1/ BG95-M2/ BG95-N1	2.4	3.3	4.8	V
			BG95-M3	3.3	3.8	4.3	V
I _{VBAT}	Peak supply	Maximum power	BG95-M3		1.8	2.0	A

	current (during transmission slot)	control level on EGSM900				
USB_VBUS	USB detection		BG95-M1/ BG95-M2/ BG95-N1/ BG95-M3	3.0	5.0	5.25 V

6.3. Operation and Storage Temperatures

The operation and storage temperatures of the module are listed in the following table.

Table 34: Operation and Storage Temperatures

Parameter	Min.	Typ.	Max.	Unit
Operation Temperature Range ¹⁾	-35	+25	+75	°C
Extended Temperature Range ²⁾	-40		+85	°C
Storage Temperature Range	-40		+90	°C

NOTES

- ¹⁾ Within operation temperature range, the module is 3GPP compliant.
- ²⁾ Within extended temperature range, the module remains the ability to establish and maintain a voice, SMS, data transmission, emergency call, etc. There is no unrecoverable malfunction. There are also no effects on radio spectrum and no harm to radio network. Only one or more parameters like Pout might reduce in their value and exceed the specified tolerances. When the temperature returns to the normal operating temperature levels, the module will meet 3GPP specifications again.

6.4. RF Output Power

The following table shows the RF output power of BG95.

Table 35: BG95 RF Output Power

Frequency	Max.	Min.
LTE-FDD B1/B2/B3/B4/B5/B8/B12/B13/B14 ¹⁾ /B18/B19/B20/B25/ B26*/B27 ¹⁾ /B28/B66/B71 ²⁾ /B85	20dBm±2dB	<-39dBm
GSM850/EGSM900	33dBm±2dB	5dBm±5dB
DCS1800/PCS1900	30dBm±2dB	0dBm±5dB
GSM850/EGSM900 (8-PSK)	27dBm±3dB	5dBm±5dB
DCS1800/PCS1900 (8-PSK)	26dBm±3dB	0dBm±5dB

NOTES

- ¹⁾ LTE-FDD B14 and B27 are supported by Cat M1 only.
- ²⁾ LTE-FDD B71 is supported by Cat NB2 only.
- “*” means under development.

6.5. RF Receiving Sensitivity

The following table shows the conducted RF receiving sensitivity of BG95.

Table 36: BG95 Conducted RF Receiving Sensitivity

Network	Band	Primary	Diversity	Sensitivity (dBm)	
				Cat M1/3GPP	Cat NB2 ¹⁾ /3GPP
LTE	LTE-FDD B1	Supported	Not Supported	TBD/-102.7	TBD/-107.5
	LTE-FDD B2			TBD /-100.3	TBD/-107.5
	LTE-FDD B3			TBD /-99.3	TBD/-107.5
	LTE-FDD B4			TBD /-102.3	TBD/-107.5
	LTE-FDD B5			TBD /-100.8	TBD/-107.5
	LTE-FDD B8			TBD /-99.8	TBD/-107.5
	LTE-FDD B12			TBD /-99.3	TBD/-107.5

LTE-FDD B13	TBD /-99.3	TBD/-107.5
LTE-FDD B14	TBD /-99.3	/
LTE-FDD B18	TBD /-102.3	TBD/-107.5
LTE-FDD B19	TBD /-102.3	TBD/-107.5
LTE-FDD B20	TBD /-99.8	TBD/-107.5
LTE-FDD B25	TBD /-100.3	TBD/-107.5
LTE-FDD B26*	TBD /-100.3	TBD/-107.5
LTE-FDD B27	TBD /-100.8	/
LTE-FDD B28	TBD /-100.8	TBD/-107.5
LTE-FDD B66	TBD	TBD/-107.5
LTE-FDD B71	/	TBD/-107.5
LTE-FDD B85	TBD	TBD/-107.5

Network	Band	Primary	Diversity	Sensitivity (dBm)
				GSM/3GPP
GSM	GSM850/EGSM900	Supported	Not Supported	TBD/-102
	DCS1800/PCS1900			TBD/-102

NOTES

- ¹⁾ LTE Cat NB2 receiving sensitivity without repetitions.
- “*” means under development.

6.6. Electrostatic Discharge

The module is not protected against electrostatics discharge (ESD) in general. Consequently, it is subject to ESD handling precautions that typically apply to ESD sensitive components. Proper ESD handling and packaging procedures must be applied throughout the processing, handling and operation of any application that incorporates the module.

The following table shows the electrostatic discharge characteristics of BG95 module.

Table 37: Electrostatic Discharge Characteristics (25°C, 45% Relative Humidity)

Tested Points	Contact Discharge	Air Discharge	Unit
VBAT, GND	TBD	TBD	kV
Main/GNSS Antenna Interfaces	TBD	TBD	kV

7 Mechanical Dimensions

This chapter describes the mechanical dimensions of the module. All dimensions are measured in mm, and the tolerances for dimensions without tolerance values are $\pm 0.05\text{mm}$.

7.1. Mechanical Dimensions of the Module

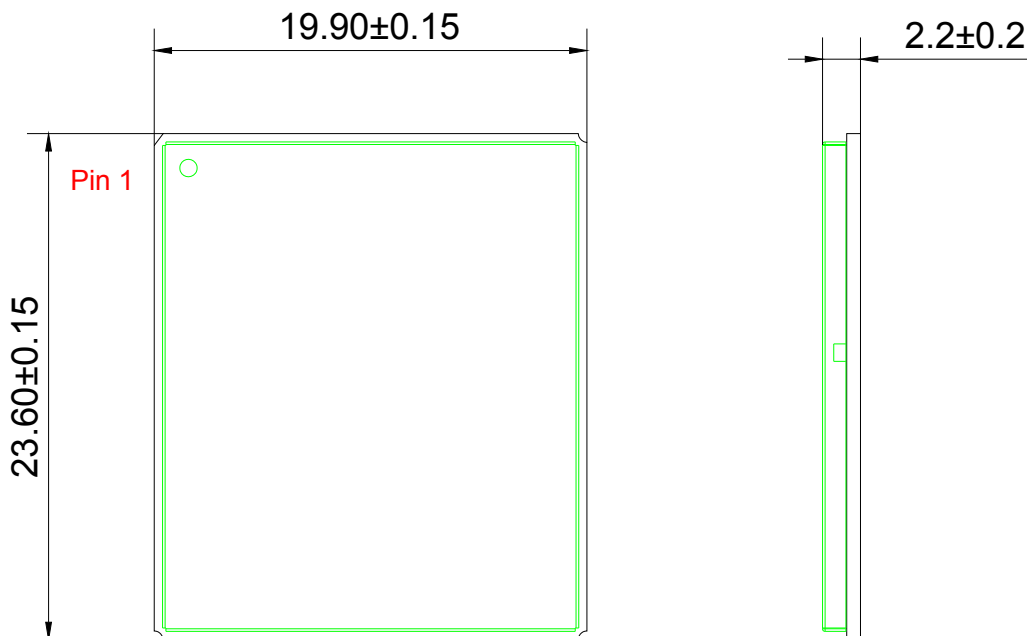

Figure 31: Module Top and Side Dimensions

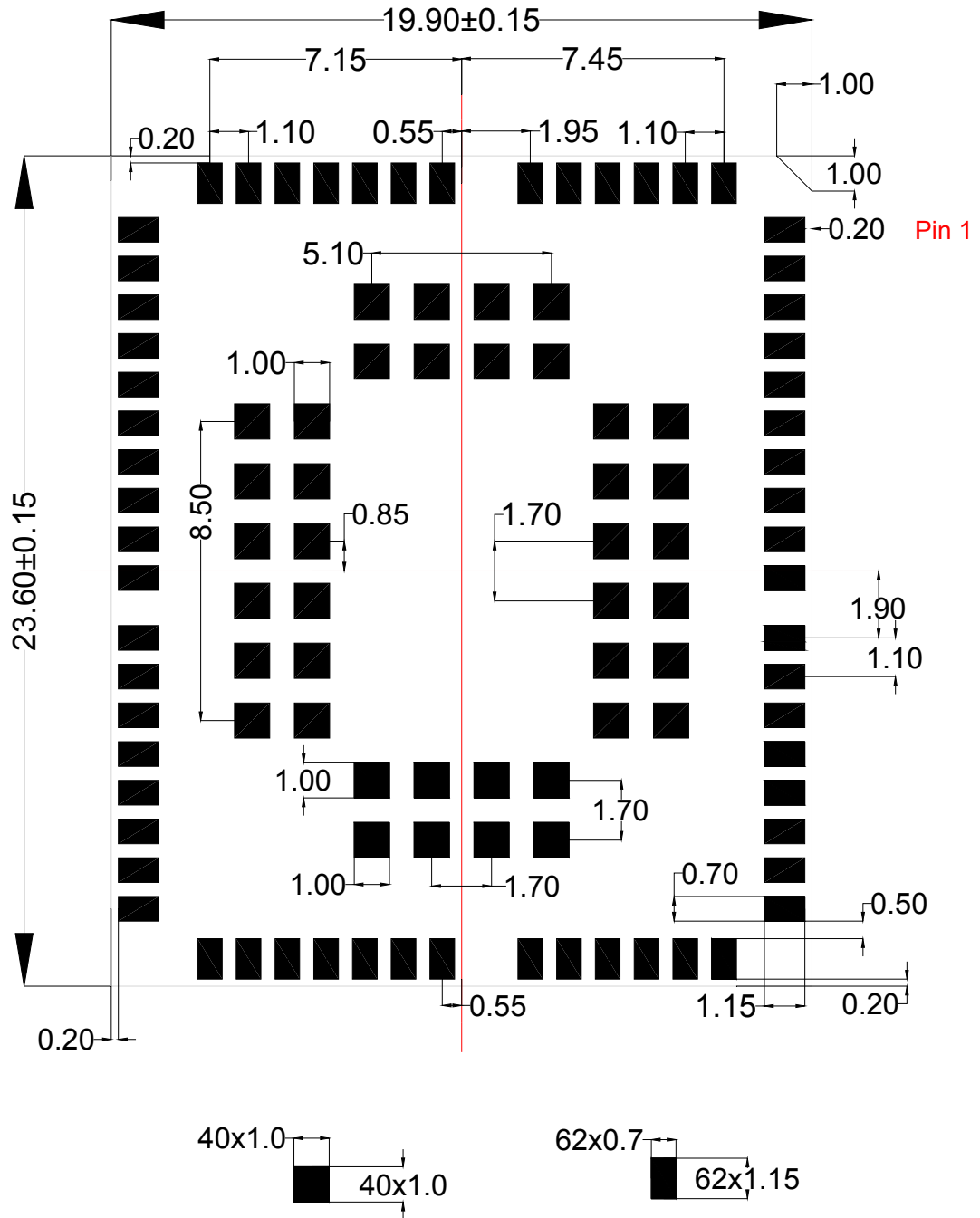

Figure 32: Module Bottom Dimensions (Bottom View)

7.2. Recommended Footprint

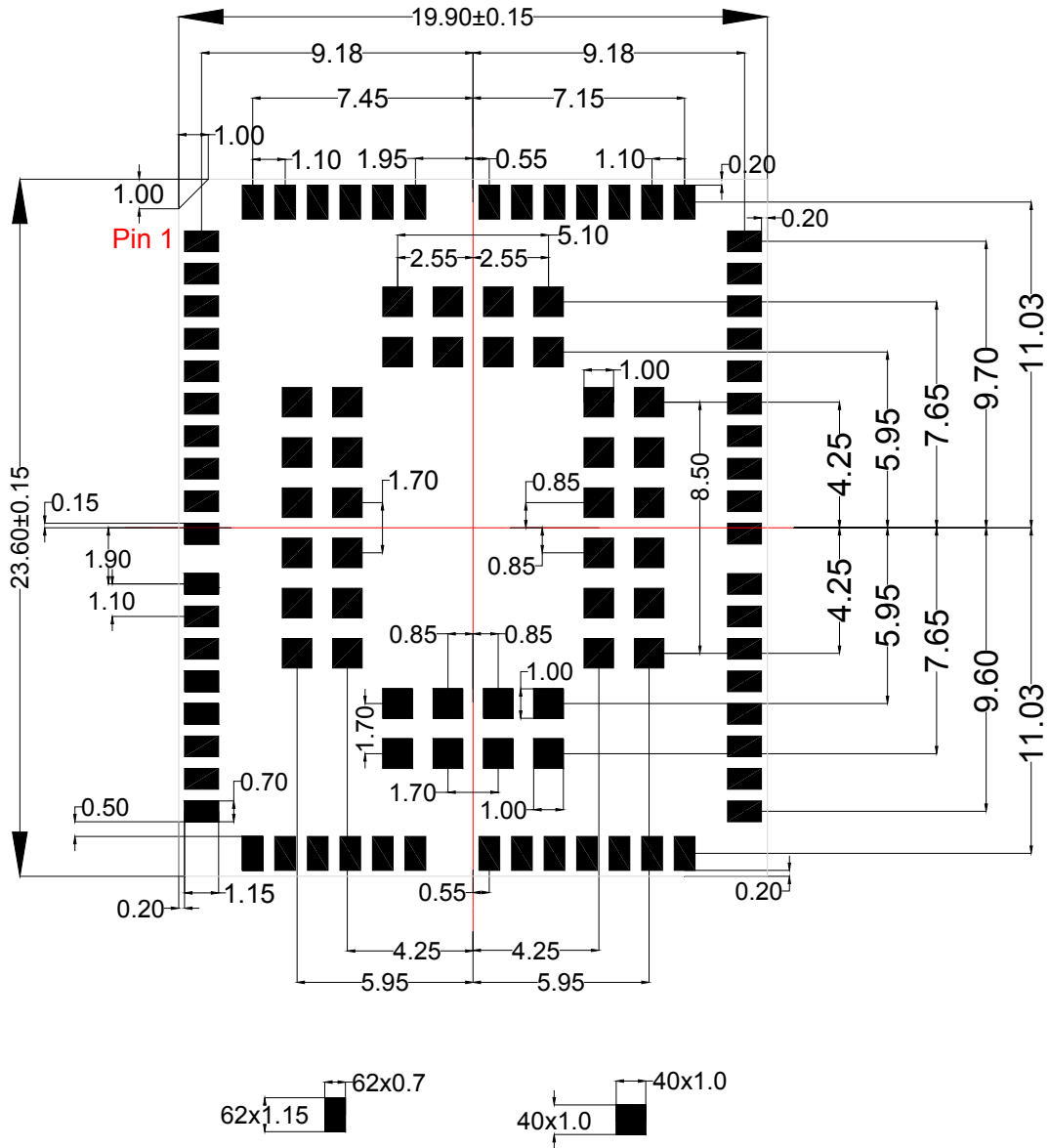

Figure 33: Recommended Footprint (Top View)

NOTES

1. For easy maintenance of the module, please keep about 3mm between the module and other components on the host PCB.
2. All reserved pins must be kept open.
3. For stencil design requirements of the module, please refer to **document [5]**.

7.3. Design Effect Drawings of the Module



Figure 34: Top View of the Module

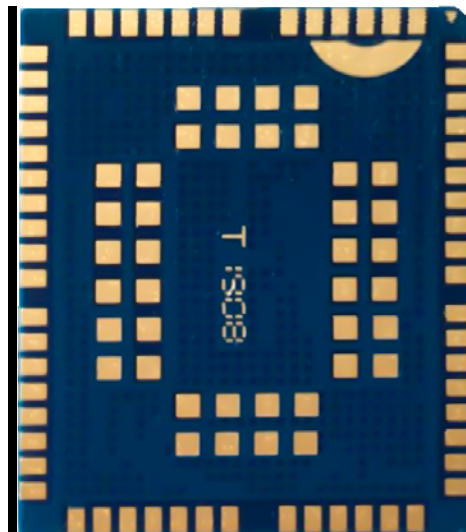

Figure 35: Bottom View of the Module

NOTE

These are renderings of BG95 module. For authentic appearance, please refer to the module that you receive from Quectel.

8 Storage, Manufacturing and Packaging

8.1. Storage

BG95 is stored in a vacuum-sealed bag. It is rated at MSL 3, and its storage restrictions are listed below.

1. Shelf life in the vacuum-sealed bag: 12 months at <math><40^{\circ}\text{C}/90\%\text{RH}</math>.
2. After the vacuum-sealed bag is opened, devices that will be subjected to reflow soldering or other high temperature processes must be:
 - Mounted within 168 hours at the factory environment of $\leq 30^{\circ}\text{C}/60\%\text{RH}$.
 - Stored at <math><10\%\text{RH}</math>.
3. Devices require baking before mounting, if any circumstance below occurs.
 - When the ambient temperature is $23^{\circ}\text{C}\pm 5^{\circ}\text{C}$ and the humidity indication card shows the humidity is >10% before opening the vacuum-sealed bag.
 - Device mounting cannot be finished within 168 hours at factory conditions of $\leq 30^{\circ}\text{C}/60\%\text{RH}$.
4. If baking is required, devices may be baked for 8 hours at $120^{\circ}\text{C}\pm 5^{\circ}\text{C}$.

NOTE

As the plastic package cannot be subjected to high temperature, it should be removed from devices before high temperature (120°C) baking. If shorter baking time is desired, please refer to *IPC/JEDECJ-STD-033* for baking procedure.

8.2. Manufacturing and Soldering

Push the squeegee to apply the solder paste on the surface of stencil, thus making the paste fill the stencil openings and then penetrate to the PCB. The force on the squeegee should be adjusted properly so as to produce a clean stencil surface on a single pass. To ensure the module soldering quality, the thickness of stencil for the module is recommended to be 0.13mm~0.15mm. For more details, please refer to **document [5]**.

It is suggested that the peak reflow temperature is 238~245°C, and the absolute maximum reflow temperature is 245°C. To avoid damage to the module caused by repeated heating, it is strongly recommended that the module should be mounted after reflow soldering for the other side of PCB has been completed. The recommended reflow soldering thermal profile (lead-free reflow soldering) and related parameters are shown below.

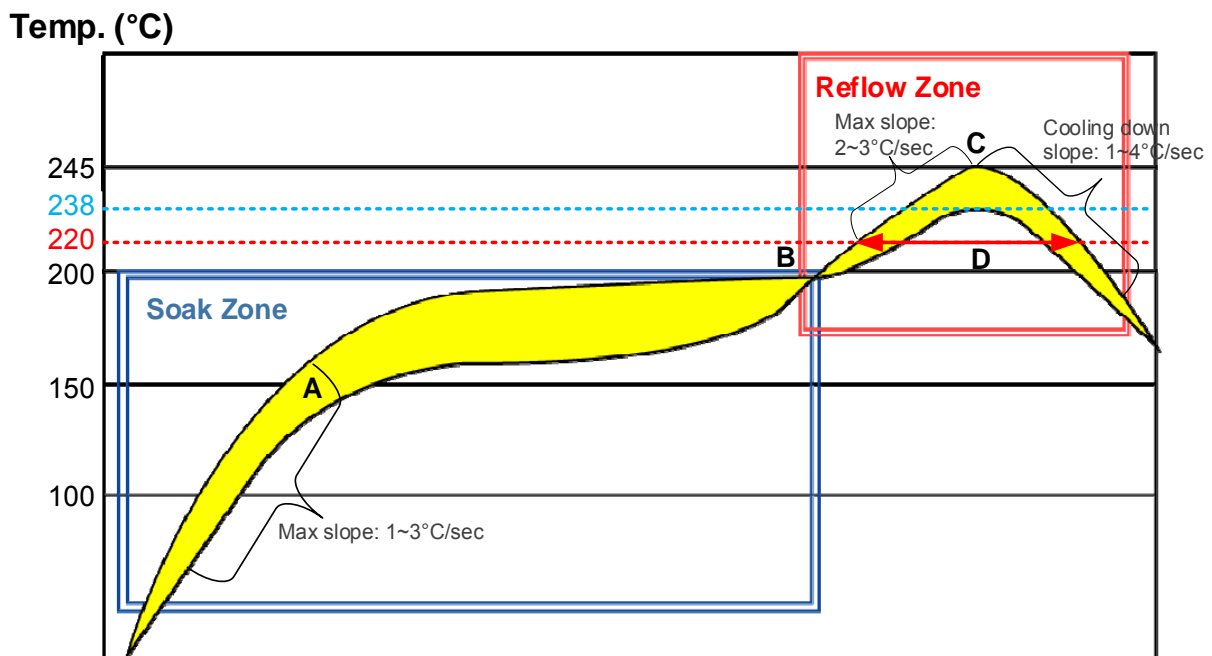

Figure 36: Recommended Reflow Soldering Thermal Profile

Table 38: Recommended Thermal Profile Parameters

Factor	Recommendation
Soak Zone	
Max slope	1 to 3°C/sec
Soak time (between A and B: 150°C and 200°C)	60 to 120 sec

Reflow Zone	
Max slope	2 to 3°C/sec
Reflow time (D: over 220°C)	40 to 60 sec
Max temperature	238°C ~ 245°C
Cooling down slope	1 to 4°C/sec
Reflow Cycle	
Max reflow cycle	1

8.3. Packaging

BG95 is packaged in a vacuum-sealed bag which is ESD protected. The bag should not be opened until the devices are ready to be soldered onto the application.

The reel is 330mm in diameter and each reel contains 250 modules. The following figures show the packaging details, measured in mm.

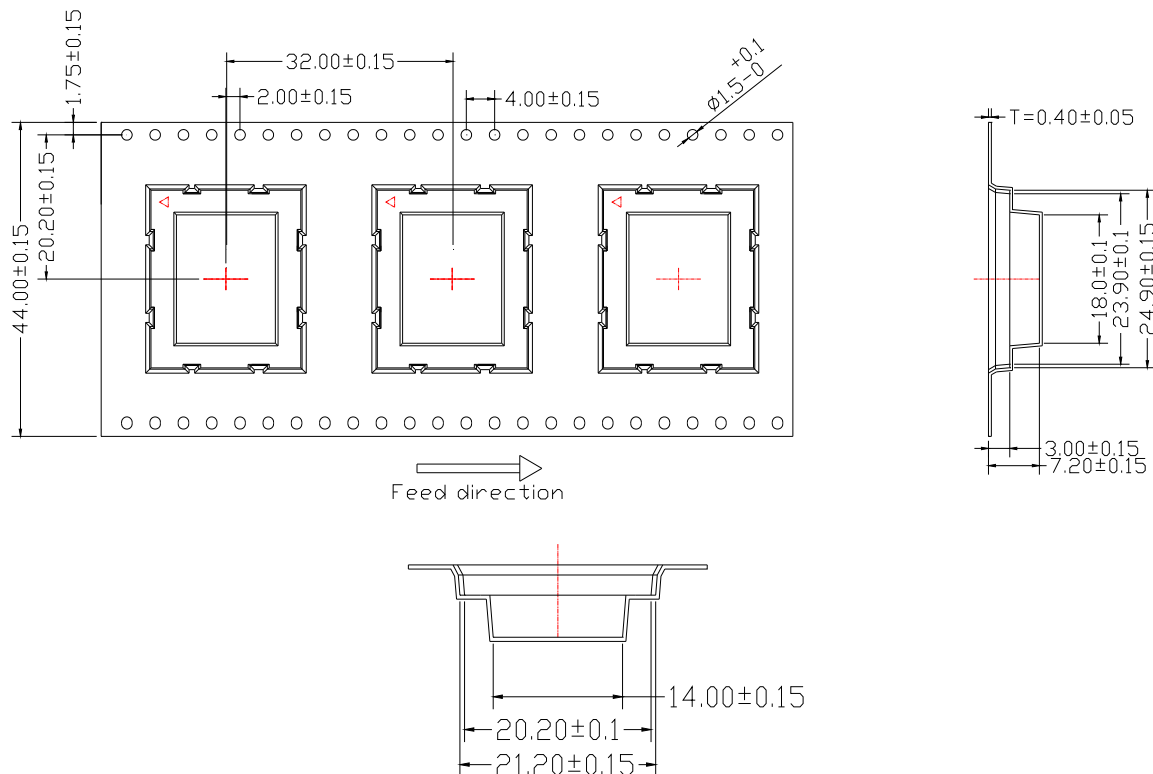

Figure 37: Tape Dimensions

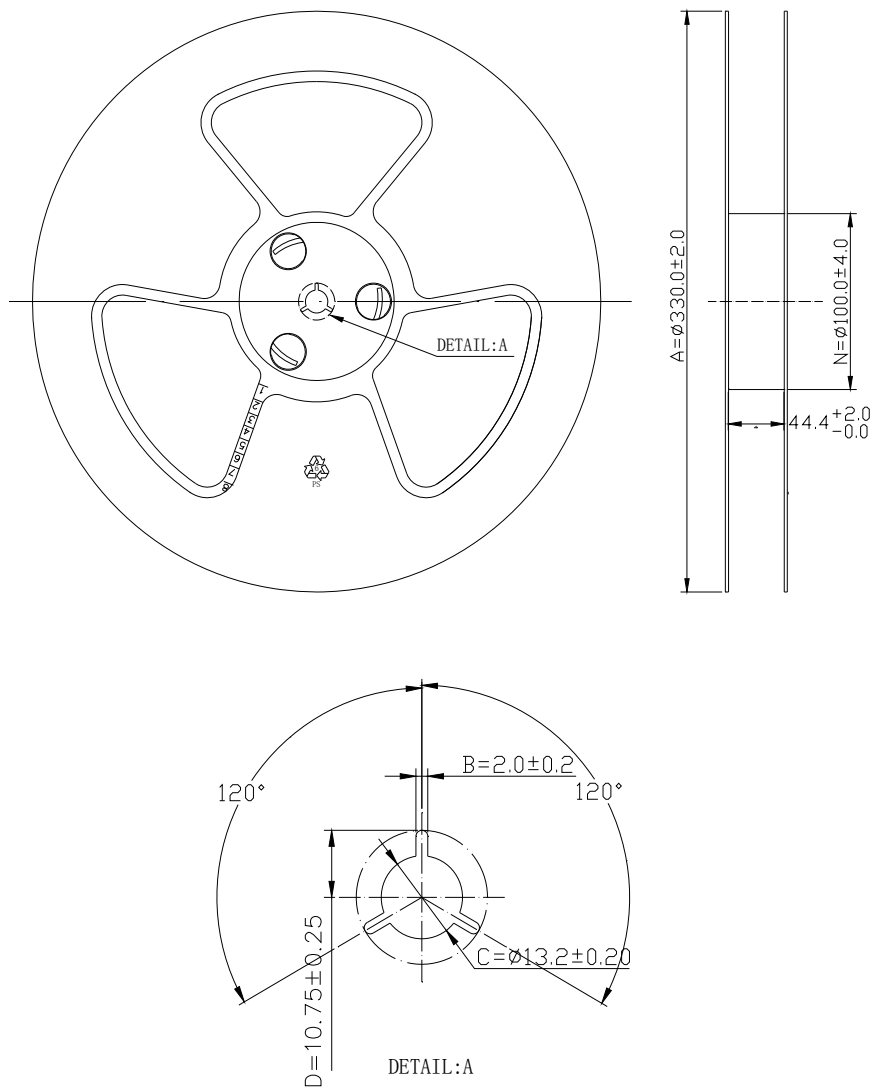

Figure 38: Reel Dimensions

Table 39: Reel Packaging

Model Name	MOQ for MP	Minimum Package: 250pcs	Minimum Package x 4=1000pcs
BG95	250pcs	Size: 370mm × 350mm × 56mm N.W: 0.61kg G.W: 1.35kg	Size: 380mm × 250mm × 365mm N.W: 2.45kg G.W: 6.28kg

9 Appendix A References

Table 40: Related Documents

SN	Document Name	Remark
[1]	Quectel_UMTS<E_EVB_User_Guide	UMTS<E EVB User Guide
[2]	Quectel_BG95_AT_Commands_Manual	BG95 AT Commands Manual
[3]	Quectel_BG95_GNSS_AT_Commands_Manual	BG95 GNSS AT Commands Manual
[4]	Quectel_RF_Layout_Application_Note	RF Layout Application Note
[5]	Quectel_Module_Secondary_SMT_User_Guide	Module Secondary SMT User Guide

Table 41: Terms and Abbreviations

Abbreviation	Description
AMR	Adaptive Multi-rate
bps	Bits Per Second
CHAP	Challenge Handshake Authentication Protocol
CS	Coding Scheme
CTS	Clear To Send
DFOTA	Delta Firmware Upgrade Over The Air
DL	Downlink
DTR	Data Terminal Ready
DTX	Discontinuous Transmission
e-I-DRX	Extended Idle Mode Discontinuous Reception
EPC	Evolved Packet Core

ESD	Electrostatic Discharge
FDD	Frequency Division Duplex
FR	Full Rate
GMSK	Gaussian Minimum Shift Keying
GSM	Global System for Mobile Communications
HSS	Home Subscriber Server
I/O	Input/Output
Inorm	Normal Current
LED	Light Emitting Diode
LNA	Low Noise Amplifier
LTE	Long Term Evolution
MO	Mobile Originated
MS	Mobile Station (GSM engine)
MT	Mobile Terminated
PAP	Password Authentication Protocol
PCB	Printed Circuit Board
PDU	Protocol Data Unit
PPP	Point-to-Point Protocol
PSM	Power Saving Mode
RF	Radio Frequency
RHCP	Right Hand Circularly Polarized
Rx	Receive
SISO	Single Input Single Output
SMS	Short Message Service
TDD	Time Division Duplexing

TX	Transmitting Direction
UL	Uplink
UE	User Equipment
URC	Unsolicited Result Code
(U)SIM	(Universal) Subscriber Identity Module
V _{max}	Maximum Voltage Value
V _{norm}	Normal Voltage Value
V _{min}	Minimum Voltage Value
V _{IHmax}	Maximum Input High Level Voltage Value
V _{IHmin}	Minimum Input High Level Voltage Value
V _{ILmax}	Maximum Input Low Level Voltage Value
V _{ILmin}	Minimum Input Low Level Voltage Value
V _{Imax}	Absolute Maximum Input Voltage Value
V _{Imin}	Absolute Minimum Input Voltage Value
V _{OHmax}	Maximum Output High Level Voltage Value
V _{OHmin}	Minimum Output High Level Voltage Value
V _{OLmax}	Maximum Output Low Level Voltage Value
V _{OLmin}	Minimum Output Low Level Voltage Value
VSWR	Voltage Standing Wave Ratio

10 Appendix B GPRS Coding Schemes

Table 42: Description of Different Coding Schemes

Scheme	CS-1	CS-2	CS-3	CS-4
Code Rate	1/2	2/3	3/4	1
USF	3	3	3	3
Pre-coded USF	3	6	6	12
Radio Block excl.USF and BCS	181	268	312	428
BCS	40	16	16	16
Tail	4	4	4	-
Coded Bits	456	588	676	456
Punctured Bits	0	132	220	-
Data Rate Kb/s	9.05	13.4	15.6	21.4

11 Appendix C GPRS Multi-slot Classes

Twenty-nine classes of GPRS multi-slot modes are defined for MS in GPRS specification. Multi-slot classes are product dependent, and determine the maximum achievable data rates in both the uplink and downlink directions. Written as 3+1 or 2+2, the first number indicates the amount of downlink timeslots, while the second number indicates the amount of uplink timeslots. The active slots determine the total number of slots the GPRS device can use simultaneously for both uplink and downlink communications.

The description of different multi-slot classes is shown in the following table.

Table 43: GPRS Multi-slot Classes

Multislot Class	Downlink Slots	Uplink Slots	Active Slots
1	1	1	2
2	2	1	3
3	2	2	3
4	3	1	4
5	2	2	4
6	3	2	4
7	3	3	4
8	4	1	5
9	3	2	5
10	4	2	5
11	4	3	5
12	4	4	5
13	3	3	NA
14	4	4	NA

15	5	5	NA
16	6	6	NA
17	7	7	NA
18	8	8	NA
19	6	2	NA
20	6	3	NA
21	6	4	NA
22	6	4	NA
23	6	6	NA
24	8	2	NA
25	8	3	NA
26	8	4	NA
27	8	4	NA
28	8	6	NA
29	8	8	NA
30	5	1	6
31	5	2	6
32	5	3	6
33	5	4	6

12 Appendix D EDGE Modulation and Coding Schemes

Table 44: EDGE Modulation and Coding Schemes

Coding Schemes	Modulation	Coding Family	1 Timeslot	2 Timeslot	4 Timeslot
CS-1	GMSK	/	9.05kbps	18.1kbps	36.2kbps
CS-2	GMSK	/	13.4kbps	26.8kbps	53.6kbps
CS-3	GMSK	/	15.6kbps	31.2kbps	62.4kbps
CS-4	GMSK	/	21.4kbps	42.8kbps	85.6kbps
MCS-1	GMSK	C	8.80kbps	17.60kbps	35.20kbps
MCS-2	GMSK	B	11.2kbps	22.4kbps	44.8kbps
MCS-3	GMSK	A	14.8kbps	29.6kbps	59.2kbps
MCS-4	GMSK	C	17.6kbps	35.2kbps	70.4kbps
MCS-5	8-PSK	B	22.4kbps	44.8kbps	89.6kbps
MCS-6	8-PSK	A	29.6kbps	59.2kbps	118.4kbps
MCS-7	8-PSK	B	44.8kbps	89.6kbps	179.2kbps
MCS-8	8-PSK	A	54.4kbps	108.8kbps	217.6kbps
MCS-9	8-PSK	A	59.2kbps	118.4kbps	236.8kbps