

EC25 MINIPCIE

Hardware Design

LTE Standard Module Series

Rev. EC25_Mini_PClE_Hardware_Design_V2.4

Date: 2019-12-18

Status: Released



Our aim is to provide customers with timely and comprehensive service. For any assistance, please contact our company headquarters:

Quectel Wireless Solutions Co., Ltd.

Building 5, Shanghai Business Park Phase III (Area B), No.1016 Tianlin Road, Minhang District, Shanghai, China 200233

Tel: +86 21 5108 6236

Email: info@quectel.com

Or our local office. For more information, please visit:

<http://www.quectel.com/support/sales.htm>

For technical support, or to report documentation errors, please visit:

<http://www.quectel.com/support/technical.htm>

Or email to: support@quectel.com

GENERAL NOTES

QUECTEL OFFERS THE INFORMATION AS A SERVICE TO ITS CUSTOMERS. THE INFORMATION PROVIDED IS BASED UPON CUSTOMERS' REQUIREMENTS. QUECTEL MAKES EVERY EFFORT TO ENSURE THE QUALITY OF THE INFORMATION IT MAKES AVAILABLE. QUECTEL DOES NOT MAKE ANY WARRANTY AS TO THE INFORMATION CONTAINED HEREIN, AND DOES NOT ACCEPT ANY LIABILITY FOR ANY INJURY, LOSS OR DAMAGE OF ANY KIND INCURRED BY USE OF OR RELIANCE UPON THE INFORMATION. ALL INFORMATION SUPPLIED HEREIN IS SUBJECT TO CHANGE WITHOUT PRIOR NOTICE.

COPYRIGHT

THE INFORMATION CONTAINED HERE IS PROPRIETARY TECHNICAL INFORMATION OF QUECTEL WIRELESS SOLUTIONS CO., LTD. TRANSMITTING, REPRODUCTION, DISSEMINATION AND EDITING OF THIS DOCUMENT AS WELL AS UTILIZATION OF THE CONTENT ARE FORBIDDEN WITHOUT PERMISSION. OFFENDERS WILL BE HELD LIABLE FOR PAYMENT OF DAMAGES. ALL RIGHTS ARE RESERVED IN THE EVENT OF A PATENT GRANT OR REGISTRATION OF A UTILITY MODEL OR DESIGN.

Copyright © Quectel Wireless Solutions Co., Ltd. 2019. All rights reserved.

About the Document

Revision History

Revision	Date	Author	Description
1.0	2016-06-07	Mountain ZHOU/ Frank WANG	Initial
1.1	2017-01-24	Lyndon LIU/ Frank WANG	<ol style="list-style-type: none"> Deleted description of EC25-AUT Mini PCIe in Table 1. Added description of EC25-AU and EC25-J Mini PCIe in Table 1. Updated key features of EC25 Mini PCIe in Table 2. Added current consumption in Chapter 4.7. Updated conducted RF receiving sensitivity of EC25-A Mini PCIe in Table 17. Added conducted RF receiving sensitivity of EC25-J Mini PCIe in Table 18.
2.0	2019-04-30	Nathan LIU/ Frank WANG/ Ward WANG/ Ethan SHAN	<ol style="list-style-type: none"> Added new variants EC25-AF Mini PCIe, EC25-EU Mini PCIe, EC25-EC Mini PCIe, EC25-EUX Mini PCIe, EC25-MX Mini PCIe and their related information. Updated LTE, UMTS and GSM features, and added storage temperature range in Table 2. Added pin definition and description of pin 3, 5, 44 in Figure 2 and Table 4. Modified the reference circuit of USB interface in Figure 6. Updated the mechanical dimension of EC25 Mini PCIe in Figure 18. Added USIM_PRESENCE in (U)SIM interface and updated the reference circuit in Chapter 3.4. Added COEX UART interface (under

			development) as UART interface in Chapter 3.6.
			8. Modified description of W_DISABLE# signal in Chapter 3.8.3.
			9. Modified description of LED_WWAN# signal in Chapter 3.8.5.
			10. Updated description of antenna connection in Chapter 5.
			11. Added thermal consideration in Chapter 6.7.
			12. Added operating frequencies in Table 16.
			13. Added GNSS frequency in Table 17.
			14. Updated antenna requirements in Table 18.
			15. Updated EC25 Mini PCIe conducted RF output power in Table 21.
			16. Updated conducted RF receiving sensitivity of EC25-A Mini PCIe in Table 22.
			17. Added conducted RF receiving sensitivity of EC25-AU Mini PCIe in Table 23.
			18. Updated conducted RF receiving sensitivity of EC25-J Mini PCIe in Table 24.
			19. Updated conducted RF receiving sensitivity of EC25-E Mini PCIe in Table 25.
			20. Updated conducted RF receiving sensitivity of EC25-V Mini PCIe in Table 26.
			21. Added conducted RF receiving sensitivity of EC25-AF Mini PCIe in Table 27.
			22. Added conducted RF receiving sensitivity of EC25-EU Mini PCIe in Table 28.
			23. Added conducted RF receiving sensitivity of EC25-EC Mini PCIe in Table 29.
			24. Added conducted RF receiving sensitivity of EC25-EUX Mini PCIe in Table 30.
			25. Added current consumption of EC25-AU Mini PCIe in Table 33.
			26. Added current consumption of EC25-J Mini PCIe in Table 34.
			27. Added current consumption of EC25-AF Mini PCIe in Table 37.
			28. Added current consumption of EC25-EC Mini PCIe in Table 38.
			29. Added current consumption of EC25-EUX Mini PCIe in Table 39.
2.1	2019-07-05	Fanny CHEN/ Ethan SHAN	1. Added EC25-AFX/-AUX Mini PCIe and related information.

			<ol style="list-style-type: none"> 2. Updated supported protocols and USB serial drivers in Table 2. 3. Added EC25-AFX Mini PCIe conducted RF receiving sensitivity in Table 28. 4. Updated conducted RF receiving sensitivity of EC25-EU Mini PCIe in Table 29. 5. Updated EC25-AF Mini PCIe current consumption in Table 39. 6. Added EC25-AFX Mini PCIe current consumption in Table 42. 7. Added EC25-MX Mini PCIe conducted RF receiving sensitivity in Table 32. 8. Added EC25-MX Mini PCIe current consumption in Table 43.
2.2	2019-08-19	Ward WANG/ Owen WEI	<ol style="list-style-type: none"> 1. Deleted the information of GNSS supported on EC25-EC Mini PCIe in Table 1. 2. Updated conducted RF receiving sensitivity of EC25-AU Mini PCIe in Table 24. 3. Updated conducted RF receiving sensitivity of EC25-EU Mini PCIe in Table 30. 4. Added conducted RF receiving sensitivity of EC25-AUX Mini PCIe in Table 34. 5. Updated current consumption of EC25-J Mini PCIe in Table 38. 6. Added current consumption of EC25-AUX Mini PCIe in Table 45. 7. Added current consumption of EC25-EU Mini PCIe in Table 46. 8. Deleted current consumption of EC21-EC Mini PCIe, and the data will be updated in the future version.
2.3	2019-11-26	Fanny CHEN	<ol style="list-style-type: none"> 1. Removed the related information of ThreadX OS because the baseline has been updated. 2. Updated the supported protocols and USB serial drivers in Table 2. 3. Added operating modes of module in Chapter 3.3. 4. Updated description of W_DISABLE# in Chapter 3.10.3. 5. Updated the notes for GNSS performance in Chapter 4.2. 6. Updated the Mini PCI Express connector type in Figure 21.

2.4	2019-12-18	Ward WANG Barret Xiong Cody Zhou	<ol style="list-style-type: none">1. Modified the I/O parameters definition of the I2C interface as OD in Table 4 and 11.2. Modified the current consumption of EC25-EUX Mini PCIe in Table 43.3. Deleted related information of EC25-EC Mini PCIe4. Added related information of EC25-T Mini PCIe5. Added related information of EC25-EX Mini PCIe
-----	------------	--	---

Contents

About the Document	2
Contents	6
Table Index	8
Figure Index	9
1 Introduction	10
1.1. FCC Certification Requirements.....	10
1.2. Safety Information.....	13
2 Product Concept	14
2.1. General Description	14
2.2. Description of Module Series	15
2.3. Key Features	17
3 Application Interfaces	20
3.1. Pin Assignment	20
3.2. Pin Description.....	21
3.3. Operating Modes	24
3.4. Power Saving.....	24
3.4.1. Sleep Mode	24
3.4.2. Airplane Mode	25
3.5. Power Supply.....	25
3.6. (U)SIM Interface	26
3.7. USB Interface	28
3.8. UART Interfaces	29
3.8.1. Main UART Interface.....	29
3.8.2. COEX UART Interface*	30
3.9. PCM and I2C Interfaces	31
3.10. Control and Indication Signals.....	34
3.10.1. RI Signal.....	34
3.10.2. DTR Signal	35
3.10.3. W_DISABLE# Signal.....	35
3.10.4. PERST# Signal	35
3.10.5. LED_WWAN# Signal	36
3.10.6. WAKE# Signal.....	37
4 GNSS Receiver	38
4.1. General Description	38
4.2. GNSS Performance	38
4.3. GNSS Frequency.....	39
5 Antenna Connection	40

5.1.	Antenna Connectors	40
5.1.1.	Operating Frequency	40
5.2.	Antenna Requirements	42
5.3.	Recommended Mating Plugs for Antenna Connection	43
6	Electrical, Reliability and Radio Characteristics	45
6.1.	General Description	45
6.2.	Power Supply Requirements	45
6.3.	I/O Requirements	46
6.4.	RF Characteristics	46
6.5.	ESD Characteristics	54
6.6.	Current Consumption	55
6.7.	Thermal Consideration	75
7	Dimensions and Packaging	77
7.1.	General Description	77
7.2.	Mechanical Dimensions of EC25 Mini PCIe	77
7.3.	Standard Dimensions of Mini PCI Express	78
7.4.	Packaging Specifications	79
8	Appendix A References	80

Table Index

TABLE 1: DESCRIPTION OF EC25 MINI PCIE	15
TABLE 2: KEY FEATURES OF EC25 MINI PCIE	17
TABLE 3: I/O PARAMETERS DEFINITION	21
TABLE 4: PIN DESCRIPTION	21
TABLE 5: OVERVIEW OF OPERATING MODES	24
TABLE 6: DEFINITION OF VCC_3V3 AND GND PINS	25
TABLE 7: PIN DEFINITION OF (U)SIM INTERFACE	26
TABLE 8: PIN DEFINITION OF USB INTERFACE	28
TABLE 9: PIN DEFINITION OF MAIN UART INTERFACE	30
TABLE 10: PIN DEFINITION OF COEX UART INTERFACE	30
TABLE 11: PIN DEFINITION OF PCM AND I2C INTERFACES	31
TABLE 12: PIN DEFINITION OF CONTROL AND INDICATION SIGNALS	34
TABLE 13: AIRPLANE MODE CONTROLLED BY HARDWARE METHOD	35
TABLE 14: AIRPLANE MODE CONTROLLED BY SOFTWARE METHOD	35
TABLE 15: INDICATIONS OF NETWORK STATUS (AT+QCFG="LEDMODE",0, DEFAULT SETTING).....	37
TABLE 16: INDICATIONS OF NETWORK STATUS (AT+QCFG="LEDMODE",2)	37
TABLE 17: GNSS PERFORMANCE	38
TABLE 18: GNSS FREQUENCY	39
TABLE 19: OPERATING FREQUENCIES	40
TABLE 20: ANTENNA REQUIREMENTS.....	42
TABLE 21: POWER SUPPLY REQUIREMENTS.....	45
TABLE 22: I/O REQUIREMENTS.....	46
TABLE 23: CONDUCTED RF OUTPUT POWER OF EC25 MINI PCIE	46
TABLE 24: CONDUCTED RF RECEIVING SENSITIVITY OF EC25-A MINI PCIE	47
TABLE 25: CONDUCTED RF RECEIVING SENSITIVITY OF EC25-AU MINI PCIE	47
TABLE 26: CONDUCTED RF RECEIVING SENSITIVITY OF EC25-J MINI PCIE	48
TABLE 27: CONDUCTED RF RECEIVING SENSITIVITY OF EC25-E MINI PCIE	48
TABLE 28: CONDUCTED RF RECEIVING SENSITIVITY OF EC25-V MINI PCIE	49
TABLE 29: CONDUCTED RF RECEIVING SENSITIVITY OF EC25-AF MINI PCIE.....	49
TABLE 30: CONDUCTED RF RECEIVING SENSITIVITY OF EC25-AFX MINI PCIE	50
TABLE 31: CONDUCTED RF RECEIVING SENSITIVITY OF EC25-EU MINI PCIE	50
TABLE 33: CONDUCTED RF RECEIVING SENSITIVITY OF EC25-EUX MINI PCIE.....	51
TABLE 34: CONDUCTED RF RECEIVING SENSITIVITY OF EC25-MX MINI PCIE.....	52
TABLE 35: CONDUCTED RF RECEIVING SENSITIVITY OF EC25-AUX MINI PCIE.....	52
TABLE 36: CONDUCTED RF RECEIVING SENSITIVITY OF EC25-EX MINI PCIE	53

Figure Index

FIGURE 2: PIN ASSIGNMENT	20
FIGURE 3: REFERENCE CIRCUIT OF POWER SUPPLY	26
FIGURE 4: REFERENCE CIRCUIT OF (U)SIM INTERFACE WITH AN 8-PIN (U)SIM CARD CONNECTOR	27
FIGURE 5: REFERENCE CIRCUIT OF (U)SIM INTERFACE WITH A 6-PIN (U)SIM CARD CONNECTOR...	27
FIGURE 6: REFERENCE CIRCUIT OF USB INTERFACE	29
FIGURE 7: REFERENCE CIRCUIT OF POWER SUPPLY	30
FIGURE 8: TIMING IN PRIMARY MODE	32
FIGURE 9: TIMING IN AUXILIARY MODE.....	33
FIGURE 10: REFERENCE CIRCUIT OF PCM APPLICATION WITH AUDIO CODEC	33
FIGURE 11: RI BEHAVIORS	34
FIGURE 12: TIMING OF RESETTING MODULE	36
FIGURE 13: LED_WWAN# SIGNAL REFERENCE CIRCUIT DIAGRAM	36
FIGURE 14: WAKE# BEHAVIOR	37
FIGURE 15: DIMENSIONS OF THE RECEPTACLE RF CONNECTORS (UNIT: MM)	43
FIGURE 16: MECHANICALS OF U.FL-LP MATING PLUGS	43
FIGURE 17: SPACE FACTOR OF MATING PLUGS (UNIT: MM)	44
FIGURE 18: REFERENCED HEATSINK DESIGN	76
FIGURE 19: MECHANICAL DIMENSIONS OF EC25 MINI PCIE	77
FIGURE 20: STANDARD DIMENSIONS OF MINI PCI EXPRESS.....	78
FIGURE 21: DIMENSIONS OF THE MINI PCI EXPRESS CONNECTOR (MOLEX 679105700).....	79

1 Introduction

This document defines EC25 Mini PCIe module, and describes its air interfaces and hardware interfaces which are connected with customers' applications.

This document helps customers quickly understand module interface specifications, electrical characteristics, mechanical specifications and other related information of the module. To facilitate application designs, it also includes some reference designs for customers' reference. The document, coupled with application notes and user guides, makes it easy to design and set up wireless applications with EC25 Mini PCIe.

1.1. FCC Certification Requirements.

According to the definition of mobile and fixed device is described in Part 2.1091(b), this device is a mobile device.

And the following conditions must be met:

1. This Modular Approval is limited to OEM installation for mobile and fixed applications only. The antenna installation and operating configurations of this transmitter, including any applicable source-based time-averaging duty factor, antenna gain and cable loss must satisfy MPE categorical Exclusion Requirements of 2.1091.
2. The EUT is a mobile device; maintain at least a 20 cm separation between the EUT and the user's body and must not transmit simultaneously with any other antenna or transmitter.
3. A label with the following statements must be attached to the host end product: This device contains
FCC ID: XMR202012EC25T
4. To comply with FCC regulations limiting both maximum RF output power and human exposure to RF radiation, maximum antenna gain (including cable loss) must not exceed:

- LTE Band2: ≤ 11.000 dB*i*
- LTE Band 4 / LTE Band 66: ≤ 5.000 dB*i*
- LTE Band 5: ≤ 9.541 dB*i*
- LTE Band 12: ≤ 8.734 dB*i*
- LTE Band 71: ≤ 8.545 dB*i*

5. This module must not transmit simultaneously with any other antenna or transmitter
6. The host end product must include a user manual that clearly defines operating requirements and conditions that must be observed to ensure compliance with current FCC RF exposure guidelines.

For portable devices, in addition to the conditions 3 through 6 described above, a separate approval is required to satisfy the SAR requirements of FCC Part 2.1093

If the device is used for other equipment that separate approval is required for all other operating configurations, including portable configurations with respect to 2.1093 and different antenna configurations.

For this device, OEM integrators must be provided with labeling instructions of finished products. Please refer to KDB784748 D01 v07, section 8. Page 6/7 last two paragraphs:

A certified modular has the option to use a permanently affixed label, or an electronic label. For a permanently affixed label, the module must be labeled with an FCC ID - Section 2.926 (see 2.2 Certification (labeling requirements) above). The OEM manual must provide clear instructions explaining to the OEM the labeling requirements, options and OEM user manual instructions that are required (see next paragraph).

For a host using a certified modular with a standard fixed label, if (1) the module's FCC ID is not visible when installed in the host, or (2) if the host is marketed so that end users do not have straightforward commonly used methods for access to remove the module so that the FCC ID of the module is visible; then an additional permanent label referring to the enclosed module: "Contains Transmitter Module FCC ID: XMR202012EC25T " or "Contains FCC ID: XMR202012EC25T " must be used. The host OEM user

manual must also contain clear instructions on how end users can find and/or access the module and the FCC ID.

The final host / module combination may also need to be evaluated against the FCC Part 15B criteria for unintentional radiators in order to be properly authorized for operation as a Part 15 digital device.

The user's manual or instruction manual for an intentional or unintentional radiator shall caution the user that changes or modifications not expressly approved by the party responsible for compliance could void the user's authority to operate the equipment. In cases where the manual is provided only in a form other than paper, such as on a computer disk or over the Internet, the information required by this section may be included in the manual in that alternative form, provided the user can reasonably be expected to have the capability to access information in that form.

This device complies with part 15 of the FCC Rules. Operation is subject to the following two conditions:

(1) This device may not cause harmful interference, and (2) this device must accept any interference received, including interference that may cause undesired operation.

Changes or modifications not expressly approved by the manufacturer could void the user's authority to operate the equipment.

1.2. Safety Information

The following safety precautions must be observed during all phases of operation, such as usage, service or repair of any cellular terminal or mobile incorporating EC25 Mini PCIe module. Manufacturers of the cellular terminal should send the following safety information to users and operating personnel, and incorporate these guidelines into all manuals supplied with the product. If not so, Quectel assumes no liability for customers' failure to comply with these precautions.



Full attention must be given to driving at all times in order to reduce the risk of an accident. Using a mobile while driving (even with a handsfree kit) causes distraction and can lead to an accident. Please comply with laws and regulations restricting the use of wireless devices while driving.



Switch off the cellular terminal or mobile before boarding an aircraft. The operation of wireless appliances in an aircraft is forbidden to prevent interference with communication systems. If the device offers an Airplane Mode, then it should be enabled prior to boarding an aircraft. Please consult the airline staff for more restrictions on the use of wireless devices on boarding the aircraft.



Wireless devices may cause interference on sensitive medical equipment, so please be aware of the restrictions on the use of wireless devices when in hospitals, clinics or other healthcare facilities.



Cellular terminals or mobiles operating over radio signals and cellular network cannot be guaranteed to connect in all possible conditions (for example, with unpaid bills or with an invalid (U)SIM card). When emergent help is needed in such conditions, please remember using emergency call. In order to make or receive a call, the cellular terminal or mobile must be switched on in a service area with adequate cellular signal strength.



The cellular terminal or mobile contains a transmitter and receiver. When it is ON, it receives and transmits radio frequency signals. RF interference can occur if it is used close to TV set, radio, computer or other electric equipment.



In locations with potentially explosive atmospheres, obey all posted signs to turn off wireless devices such as your phone or other cellular terminals. Areas with potentially explosive atmospheres include fuelling areas, below decks on boats, fuel or chemical transfer or storage facilities, areas where the air contains chemicals or particles such as grain, dust or metal powders, etc.

2 Product Concept

2.1. General Description

EC25 Mini PCIe module provides data connectivity on LTE-FDD, LTE-TDD, DC-HSDPA, HSPA+, HSDPA, HSUPA, WCDMA, EDGE and GPRS networks with PCI Express Mini Card 1.2 standard interface. It supports embedded operating systems such as Linux, Android, etc., and also provides audio, high-speed data transmission and GNSS functionalities for customers' applications.

EC25 Mini PCIe module can be applied in the following fields:

- PDA and Laptop Computer
- Remote Monitor System
- Vehicle System
- Wireless POS System
- Intelligent Meter Reading System
- Wireless Router and Switch
- Other Wireless Terminal Devices

This chapter generally introduces the following aspects of EC25 Mini PCIe module:

- Product Series
- Key Features
- Functional Diagram

NOTE

EC25 Mini PCIe contains **Telematics** version and **Data-only** version. **Telematics** version supports voice and data functions, while **Data-only** version only supports data function.

2.2. Description of Module Series

EC25 Mini PCIe series contains 12 variants, and are listed in the following table.

Table 1: Description of EC25 Mini PCIe

Module Series	Description
EC25-A Mini PCIe	Support LTE-FDD: B2/B4/B12 Support WCDMA: B2/B4/B5 Support LTE/WCDMA receive diversity Support GNSS ¹⁾ Support digital audio ²⁾
EC25-AU Mini PCIe ³⁾	Support LTE-FDD: B1/B2/B3/B4/B5/B7/B8/B28 Support LTE-TDD: B40 Support WCDMA: B1/B2/B5/B8 Support GSM: 850/900/1800/1900MHz Support LTE/WCDMA receive diversity ³⁾ Support GNSS ¹⁾ Support digital audio ²⁾
EC25-J Mini PCIe	Support LTE-FDD: B1/B3/B8/B18/B19/B26 Support LTE-TDD: B41 Support WCDMA: B1/B6/B8/B19 Support LTE/WCDMA receive diversity Support GNSS ¹⁾ Support digital audio ²⁾
EC25-E Mini PCIe	Support LTE-FDD: B1/B3/B5/B7/B8/B20 Support LTE-TDD: B38/B40/B41 Support WCDMA: B1/B5/B8 Support GSM: 900/1800MHz Support LTE/WCDMA receive diversity Support GNSS ¹⁾ Support digital audio ²⁾
EC25-V Mini PCIe	Support LTE-FDD: B4/B13 Support LTE receive diversity Support GNSS ¹⁾ Support digital audio ²⁾
EC25-AF Mini PCIe	Support LTE-FDD: B2/B4/B5/B12/B13/B14/B66/B71 Support WCDMA: B2/B4/B5 Support LTE/WCDMA receive diversity Support GNSS ¹⁾ Support digital audio ²⁾

EC25-EU Mini PCIe	<p>Support LTE-FDD: B1/B3/B7/B8/B20/B28A Support LTE-TDD: B38/B40/B41 Support WCDMA: B1/B8 Support GSM: 900/1800MHz Support LTE/WCDMA receive diversity Support GNSS¹⁾ Support digital audio²⁾</p>
EC25-EUX Mini PCIe	<p>Support LTE-FDD: B1/B3/B7/B8/B20/B28A Support LTE-TDD: B38/B40/B41 Support WCDMA: B1/B8 Support GSM: 900/1800MHz Support LTE/WCDMA receive diversity Support GNSS¹⁾ Support digital audio²⁾</p>
EC25-MX Mini PCIe	<p>Support LTE-FDD: B2/B4/B5/B7/B28/B66 Support WCDMA: B2/B4/B5 Support LTE/WCDMA receive diversity Support digital audio²⁾</p>
EC25-AFX Mini PCIe	<p>Support LTE-FDD: B2/B4/B5/B12/B13/B14/B66/B71 Support WCDMA: B2/B4/B5 Support LTE/WCDMA receive diversity Support GNSS¹⁾ Support digital audio²⁾</p>
EC25-AUX Mini PCIe ³⁾	<p>Support LTE-FDD: B1/B2/B3/B4/B5/B7/B8/B28³⁾ Support LTE-TDD: B40 Support WCDMA: B1/B2/B4/B5/B8 Support GSM: 850/900/1800/1900MHz Support LTE/WCDMA receive diversity³⁾ Support GNSS¹⁾ Support digital audio²⁾</p>
EC25-EX Mini PCIe	<p>Support LTE-FDD: B1/B3/B5/B7/B8/B20 Support LTE-TDD: B38/B40/B41 Support WCDMA: B1/B5/B8 Support GSM: 900/1800MHz Support digital audio²⁾</p>
EC25-T Mini PCIe	<p>Support LTE-FDD: B2/B4/B5/B12/ B66/B71 Support LTE receive diversity Support GNSS¹⁾ Support digital audio²⁾</p>

NOTES

1. ¹⁾ GNSS function is optional.
2. ²⁾ Digital audio (PCM) function is only supported on **Telematics** version.
3. ³⁾ B2 on EC25-AU and EC25-AUX Mini PCIe does not support Rx-diversity.

2.3. Key Features

The following table describes the detailed features of EC25 Mini PCIe module.

Table 2: Key Features of EC25 Mini PCIe

Features	Description
Function Interface	PCI Express Mini Card 1.2 Standard Interface
Power Supply	Supply voltage: 3.0V~3.6V Typical supply voltage: 3.3V
Transmitting Power	Class 4 (33dBm±2dB) for GSM850 Class 4 (33dBm±2dB) for EGSM900 Class 1 (30dBm±2dB) for DCS1800 Class 1 (30dBm±2dB) for PCS1900 Class E2 (27dBm±3dB) for GSM850 8-PSK Class E2 (27dBm±3dB) for EGSM900 8-PSK Class E2 (26dBm±3dB) for DCS1800 8-PSK Class E2 (26dBm±3dB) for PCS1900 8-PSK Class 3 (24dBm+1/-3dB) for WCDMA bands Class 3 (23dBm±2dB) for LTE-FDD bands Class 3 (23dBm±2dB) for LTE-TDD bands
LTE Features	Support up to 3GPP R8 non-CA Cat 4 FDD and TDD Support 1.4/3/5/10/15/20MHz RF bandwidth Support MIMO in DL direction LTE-FDD: Max 150Mbps (DL)/Max 50Mbps (UL) LTE-TDD: Max 130Mbps (DL)/Max 30Mbps (UL)
UMTS Features	Support 3GPP R8 DC-HSDPA, HSPA+, HSDPA, HSUPA and WCDMA Support QPSK, 16-QAM and 64-QAM modulation DC-HSDPA: Max 42Mbps (DL) HSUPA: Max 5.76Mbps (UL) WCDMA: Max 384Kbps (DL)/Max 384Kbps (UL)
GSM Features	GPRS: Support GPRS multi-slot class 33 (33 by default)

	<p>Coding scheme: CS-1, CS-2, CS-3 and CS-4 Max 107Kbps (DL)/Max 85.6Kbps (UL)</p> <p>EDGE: Support EDGE multi-slot class 33 (33 by default) Support GMSK and 8-PSK for different MCS (Modulation and Coding Scheme) Downlink coding schemes: CS 1-4 and MCS 1-9 Uplink coding schemes: CS 1-4 and MCS 1-9 Max 296Kbps (DL)/Max 236.8Kbps (UL)</p>
Internet Protocol Features	<p>Support TCP/UDP/PPP/FTP/FTPS/HTTP/HTTPS/NTP/PING/QMI/NITZ/SMTP/SSL/MQTT/CMUX/SMTPS/MMS*/FILE* protocols Support protocols PAP (Password Authentication Protocol) and CHAP (Challenge Handshake Authentication Protocol) which are usually used for PPP connection</p>
SMS	<p>Text and PDU modes Point-to-point MO and MT SMS cell broadcast SMS storage: ME by default</p>
(U)SIM Interface	Support USIM/SIM card: 1.8V, 3.0V
UART Interfaces	<p>Main UART: Support RTS and CTS hardware flow control Baud rate can reach up to 230400bps, 115200bps by default Used for AT command communication and data transmission</p> <p>COEX UART*: LTE/WLAN&BT coexistence UART</p>
Audio Features	<p>Support one digital audio interface: PCM interface GSM: HR/FR/EFR/AMR/AMR-WB WCDMA: AMR/AMR-WB LTE: AMR/AMR-WB Support echo cancellation and noise suppression</p>
PCM Interface	<p>Support 16-bit linear data format Support long frame synchronization and short frame synchronization Support master and slave modes, but must be the master in long frame synchronization</p>
USB Interface	<p>Compliant with USB 2.0 specification (slave only); the data transfer rate can reach up to 480Mbps Used for AT command communication, data transmission, firmware upgrade, software debugging, GNSS NMEA output and voice over USB. Support USB serial drivers for: Windows 7/8/8.1/10, Linux 2.6~5.4, Android 4.x/5.x/6.x/7.x/8.x/9.x, etc.</p>
Antenna Connectors	Include main antenna, diversity antenna and GNSS antenna receptacle connectors

Rx-diversity (Optional)	Support LTE/WCDMA Rx-diversity
GNSS Features	Gen8C Lite of Qualcomm Protocol: NMEA 0183 Data update rate: 1Hz by default
AT Commands	Compliant with 3GPP TS 27.007, 27.005 and Quectel enhanced AT commands
Physical Characteristics	Size: (51.0±0.15)mm × (30.0±0.15)mm × (4.9±0.2)mm Weight: approx. 9.8g
Temperature Range	Operation temperature range: -35°C to +75°C ¹⁾ Extended temperature range: -40°C to +80°C ²⁾ Storage temperature range: -40°C to +90°C
Firmware Upgrade	Upgrade via USB interface or DFOTA
RoHS	All hardware components are fully compliant with EU RoHS directive

NOTES

- ¹⁾ Within operation temperature range, the module is 3GPP compliant.
- ²⁾ Within extended temperature range, the module remains the ability to establish and maintain a voice, SMS, data transmission, emergency call*, etc. There is no unrecoverable malfunction. There are also no effects on radio spectrum and no harm to radio network. Only one or more parameters like P_{out} might reduce in their value and exceed the specified tolerances. When the temperature returns to normal operation temperature levels, the module will meet 3GPP specifications again.
- “*” means under development.

3 Application Interfaces

The physical connections and signal levels of EC25 Mini PCIe comply with PCI Express Mini Card Electromechanical Specification. This chapter mainly describes the definition and application of the following interfaces/pins of EC25 Mini PCIe.

- Power supply
- (U)SIM interface
- USB interface
- UART interfaces
- PCM and I2C interfaces
- Control and indication pins

3.1. Pin Assignment

The following figure shows the pin assignment of EC25 Mini PCIe module. The top side contains EC25 module and antenna connectors.

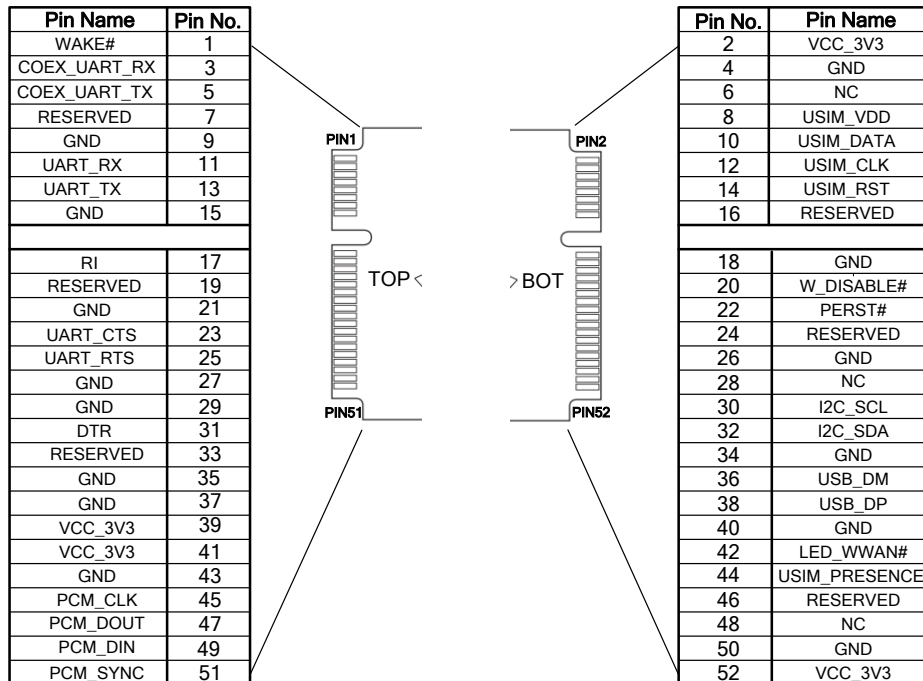

Figure 1: Pin Assignment

3.2. Pin Description

The following tables show the pin definition and description of the 52 pins on EC25 Mini PCIe.

Table 3: I/O Parameters Definition

Type	Description
DI	Digital Input
DO	Digital Output
IO	Bidirectional
OC	Open Collector
PI	Power Input
PO	Power Output
OD	Open drain

Table 4: Pin Description

Pin No.	Mini PCI Express Standard Name	EC25 Mini PCIe Pin Name	I/O	Description	Comment
1	WAKE#	WAKE#	OC	Output signal used to wake up the host.	
2	3.3Vaux	VCC_3V3	PI	3.0V~3.6V, typically 3.3V DC supply	
3	COEX1	COEX_UART_RX	DI	LTE/WLAN&BT coexistence receive signal	It is prohibited to be pulled up high before startup.
4	GND	GND		Mini card ground	
5	COEX2	COEX_UART_TX	DO	LTE/WLAN&BT coexistence transmitting signal	It is prohibited to be pulled up high before startup.
6	1.5V	NC		Not connected	
7	CLKREQ#	RESERVED		Reserved	

8	UIM_PWR	USIM_VDD	PO	Power supply for the (U)SIM card	
9	GND	GND		Mini card ground	
10	UIM_DATA	USIM_DATA	IO	Data signal of (U)SIM card	
11	REFCLK-	UART_RX	DI	UART receive data	Connect to DTE's TX.
12	UIM_CLK	USIM_CLK	DO	Clock signal of (U)SIM card	
13	REFCLK+	UART_TX	DO	UART transmit data	Connect to DTE's RX.
14	UIM_RESET	USIM_RST	DO	Reset signal of (U)SIM card	
15	GND	GND		Mini card ground	
16	UIM_VPP	RESERVED		Reserved	
17	RESERVED	RI	DO	Ring indication	
18	GND	GND		Mini card ground	
19	RESERVED	RESERVED		Reserved	
20	W_DISABLE#	W_DISABLE#	DI	Airplane mode control	Pulled up by default. Active low.
21	GND	GND		Mini card ground	
22	PERST#	PERST#	DI	Fundamental reset signal	Pulled up by default. Active low.
23	PERn0	UART_CTS	DI	UART clear to send	Connect to DTE's RTS.
24	3.3Vaux	RESERVED		Reserved	
25	PERp0	UART_RTS	DO	UART request to send	Connect to DTE's CTS.
26	GND	GND		Mini card ground	
27	GND	GND		Mini card ground	
28	1.5V	NC		Not connected	
29	GND	GND		Mini card ground	

30	SMB_CLK	I2C_SCL	OD	I2C serial clock	Require external pull-up to 1.8V.
31	PETn0	DTR	DI	Sleep mode control	
32	SMB_DATA	I2C_SDA	OD	I2C serial data	Require external pull-up to 1.8V.
33	PETp0	RESERVED		Reserved	
34	GND	GND		Mini card ground	
35	GND	GND		Mini card ground	
36	USB_D-	USB_DM	IO	USB differential data (-)	Require differential impedance of 90Ω.
37	GND	GND		Mini card ground	
38	USB_D+	USB_DP	IO	USB differential data (+)	Require differential impedance of 90Ω.
39	3.3Vaux	VCC_3V3	PI	3.0V~3.6V, typically 3.3V DC supply	
40	GND	GND		Mini card ground	
41	3.3Vaux	VCC_3V3	PI	3.0V~3.6V, typically 3.3V DC supply	
42	LED_WWAN#	LED_WWAN#	OC	LED signal for indicating the network status of the module	Active low
43	GND	GND		Mini card ground	
44	LED_WLAN#	USIM_PRESENCE	DI	(U)SIM card insertion detection	
45	RESERVED	PCM_CLK ¹⁾	IO	PCM clock signal	
46	LED_WPAN#	RESERVED		Reserved	
47	RESERVED	PCM_DOUT ¹⁾	DO	PCM data output	
48	1.5V	NC		Not connected	
49	RESERVED	PCM_DIN ¹⁾	DI	PCM data input	

50	GND	GND		Mini card ground
51	RESERVED	PCM_SYNC ¹⁾	IO	PCM frame synchronization
52	3.3Vaux	VCC_3V3	PI	3.0V~3.6V, typically 3.3V DC supply

NOTES

- ¹⁾ The digital audio (PCM) function is only supported on **Telematics** version.
- Keep all NC, reserved and unused pins unconnected.

3.3. Operating Modes

The following table briefly outlines the operating modes to be mentioned in the following chapters.

Table 5: Overview of Operating Modes

Mode	Details	
Normal Operation	Idle	Software is active. The module has registered on the network, and it is ready to send and receive data.
	Talk/Data	Network connection is ongoing. In this mode, the power consumption is decided by network setting and data transfer rate.
Minimum Functionality Mode	AT+CFUN command can set the module to a minimum functionality mode without removing the power supply. In this case, both RF function and (U)SIM card will be invalid.	
Airplane Mode	AT+CFUN command or W_DISABLE# pin can set the module to airplane mode. In this case, RF function will be invalid.	
Sleep Mode	In this mode, the current consumption of the module will be reduced to the minimal level. In this mode, the module can still receive paging message, SMS, voice call and TCP/UDP data from the network normally.	

3.4. Power Saving

3.4.1. Sleep Mode

EC25 Mini PCIe is able to reduce its current consumption to a minimum value in sleep mode. There are three preconditions must be met to make the module enter sleep mode.

- Execute **AT+QSCLK=1** to enable sleep mode.
- Ensure the DTR is kept at high level or be kept open.
- The host's USB bus, which is connected with the module's USB interface, enters suspend state.

3.4.2. Airplane Mode

When the module enters airplane mode, the RF function will be disabled, and all AT commands related to it will be inaccessible. For more details, please refer to **Chapter 3.10.3**.

3.5. Power Supply

The following table shows pin definition of VCC_3V3 pins and ground pins.

Table 6: Definition of VCC_3V3 and GND Pins

Pin Name	Pin No.	I/O	Power Domain	Description
VCC_3V3	2, 39, 41, 52	PI	3.0V~3.6V	Typically 3.3V DC supply
GND	4, 9, 15, 18, 21, 26, 27, 29, 34, 35, 37, 40, 43, 50			Mini card ground

The typical supply voltage of EC25 Mini PCIe is 3.3V. In the 2G network, the input peak current may reach 2.7A during the transmitting time. Therefore, the power supply must be able to provide a rated output current of 2.7A at least, and a bypass capacitor of no less than 470μF with low ESR should be used to prevent the voltage from dropping. If the switching power supply is used to supply power to the module, the power device and power supply routing traces of the switching power supply should avoid the antennas as much as possible to prevent EMI interference.

The following figure shows a reference design of power supply where R2 and R3 are 1% tolerance resistors and C3 is a low-ESR capacitor.

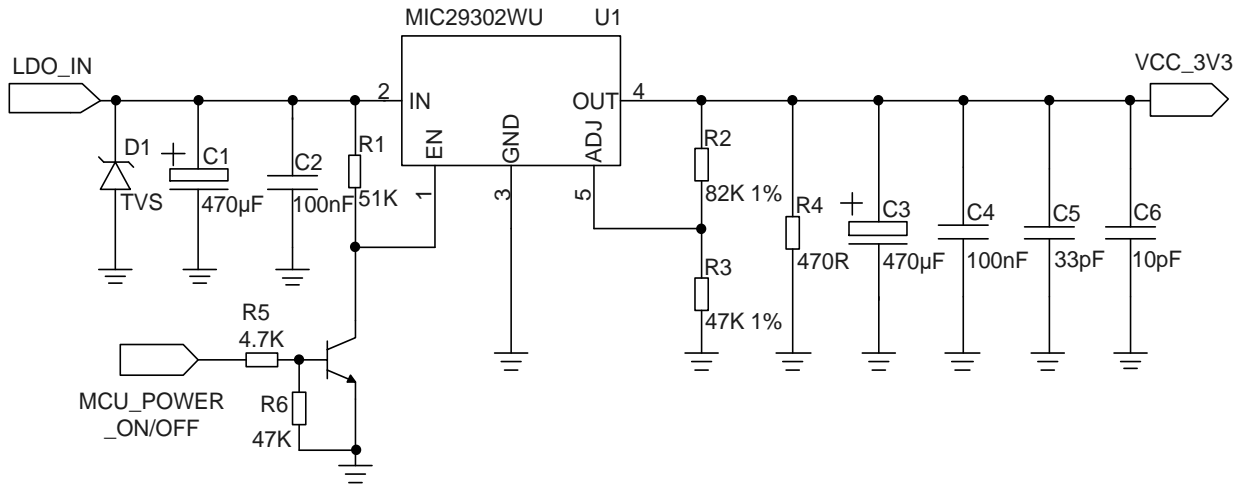

Figure 2: Reference Circuit of Power Supply

3.6. (U)SIM Interface

EC25 Mini PCIe's (U)SIM interface circuitry meets ETSI and IMT-2000 requirements. Both 1.8V and 3.0V (U)SIM cards are supported. The following table shows the pin definition of (U)SIM interface.

Table 7: Pin Definition of (U)SIM Interface

Pin Name	Pin No.	I/O	Power Domain	Description
USIM_VDD	8	PO	1.8V/3.0V	Power supply for (U)SIM card
USIM_DATA	10	IO	1.8V/3.0V	Data signal of (U)SIM card
USIM_CLK	12	DO	1.8V/3.0V	Clock signal of (U)SIM card
USIM_RST	14	DO	1.8V/3.0V	Reset signal of (U)SIM card
USIM_PRESENCE	44	DI	1.8V	(U)SIM card insertion detection

EC25 Mini PCIe supports (U)SIM card hot-plug via the USIM_PRESENCE pin. The function supports low level and high level detections. By default, It is disabled, and can be configured via **AT+QSIMDET** command. Please refer to **document [2]** for details about the command.

The following figure shows a reference design for (U)SIM interface with an 8-pin (U)SIM card connector.

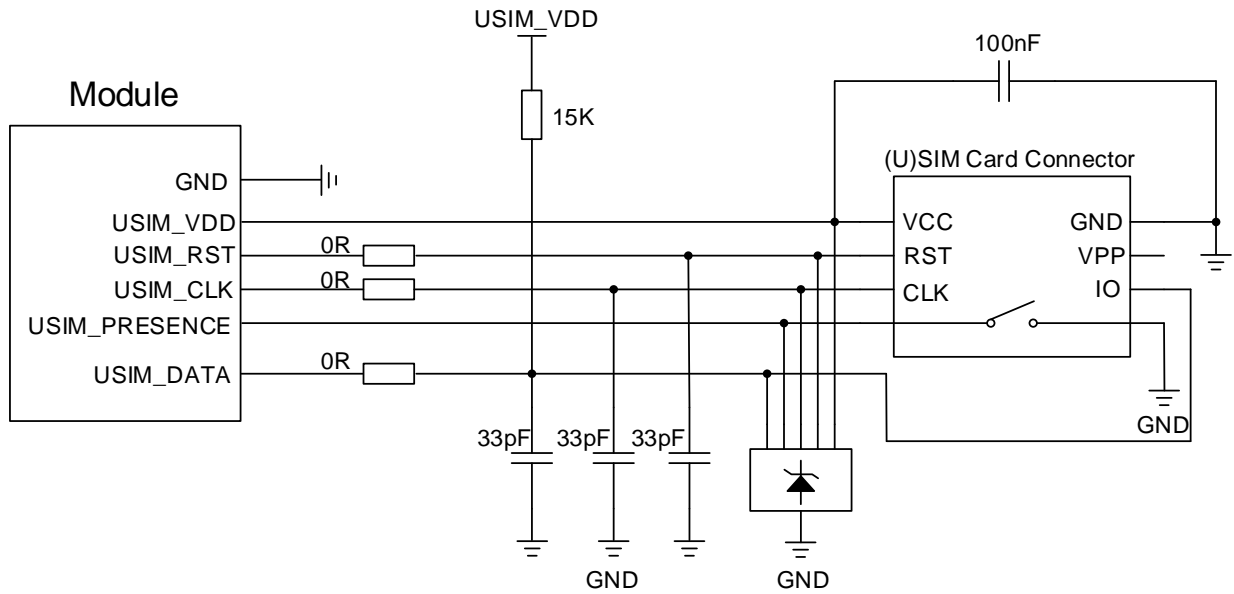

Figure 3: Reference Circuit of (U)SIM Interface with an 8-pin (U)SIM Card Connector

If (U)SIM card detection function is not needed, please keep USIM_PRESENCE unconnected. A reference circuit for (U)SIM interface with a 6-pin (U)SIM card connector is illustrated in the following figure.

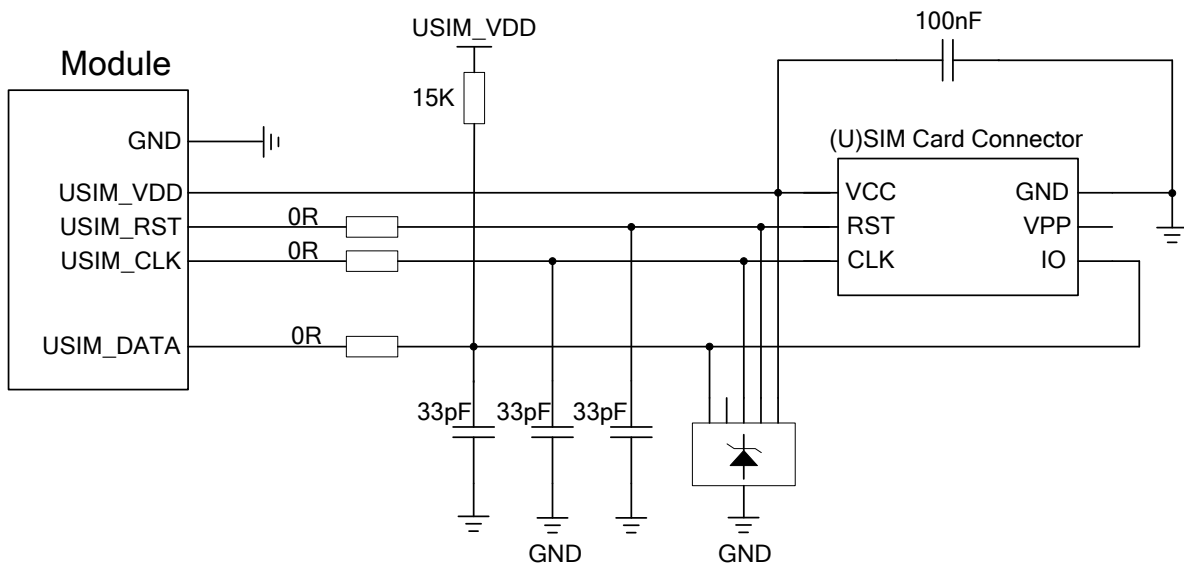

Figure 4: Reference Circuit of (U)SIM Interface with a 6-pin (U)SIM Card Connector

In order to enhance the reliability and availability of the (U)SIM card in customers' applications, please follow the criteria below in (U)SIM circuit design:

- Keep placement of (U)SIM card connector to the module as close as possible. Keep the trace length as less than 200mm as possible.
- Keep (U)SIM card signals away from RF and power supply traces.
- To avoid cross-talk between USIM_DATA and USIM_CLK, keep them away from each other and shield them with surrounded ground.
- In order to offer good ESD protection, it is recommended to add a TVS diode with parasitic capacitance not exceeding 15pF.
- The 0Ω resistors should be added in series between the module and the (U)SIM card connector so as to facilitate debugging. The 33pF capacitors are used for filtering interference of EGSM900. Please note that the (U)SIM peripheral circuit should be close to the (U)SIM card connector.
- The pull-up resistor on USIM_DATA line can improve anti-jamming capability when long layout trace and sensitive occasion are applied, and should be placed close to the (U)SIM card connector.

3.7. USB Interface

EC25 Mini PCIe provides one integrated Universal Serial Bus (USB) interface which complies with USB 2.0 specification. It can only be used as a slave device. Meanwhile, it supports high speed (480Mbps) mode and full speed (12Mbps) mode. The USB interface is used for AT command communication, data transmission, GNSS NMEA output, software debugging, firmware upgrade and voice over USB.

The following table shows the pin definition of USB interface.

Table 8: Pin Definition of USB Interface

Pin Name	Pin No.	I/O	Description	Comment
USB_DM	36	IO	USB differential data (-)	Require differential impedance of 90Ω
USB_DP	38	IO	USB differential data (+)	Require differential impedance of 90Ω

The following figure shows a reference circuit of USB interface.

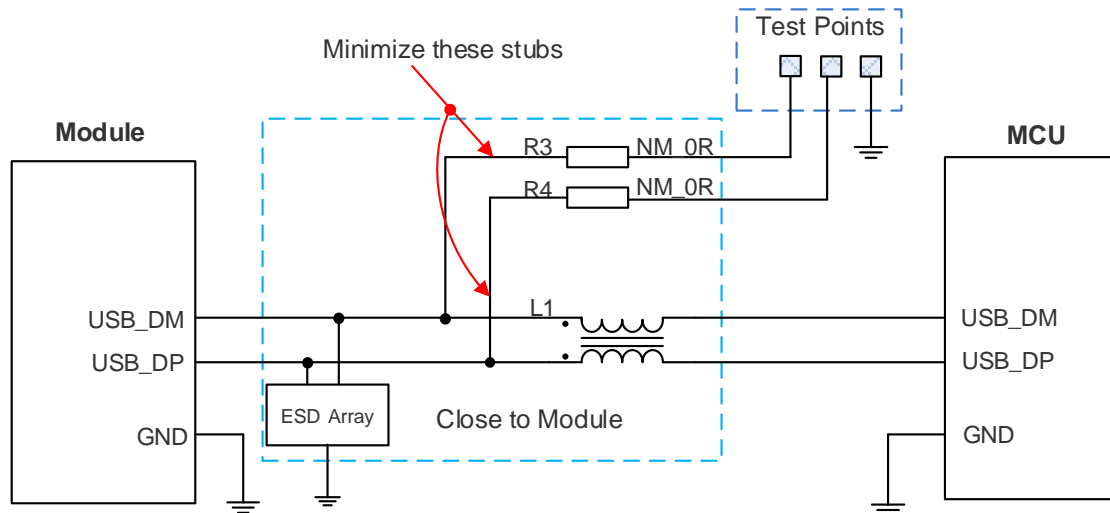

Figure 5: Reference Circuit of USB Interface

A common mode choke L1 is recommended to be added in series between the module and customer's MCU in order to suppress EMI spurious transmission. Meanwhile, the 0Ω resistors (R3 and R4) should be added in series between the module and the test points so as to facilitate debugging, and the resistors are not mounted by default. In order to ensure the integrity of USB data line signal, L1/R3/R4 components must be placed close to the module, and also these resistors should be placed close to each other. The extra stubs of trace must be as short as possible.

The following principles should be complied with when design the USB interface, so as to meet USB 2.0 specification.

- It is important to route the USB signal traces as differential pairs with total grounding. The impedance of USB differential trace is 90Ω.
- Do not route signal traces under crystals, oscillators, magnetic devices and RF signal traces. It is important to route the USB differential traces in inner layer with ground shielding on not only upper and lower layers but also right and left sides.
- Keep the ESD protection components to the USB connector as close as possible.

3.8. UART Interfaces

The following table shows the pin definition of the main UART and COEX UART* interfaces.

3.8.1. Main UART Interface

The main UART interface supports 9600bps, 19200bps, 38400bps, 57600bps, 115200bps and 230400bps baud rates, and the default is 115200bps. This interface supports RTS and CTS hardware flow control, and be used for AT command communication and data transmission.

The following table shows the pin definition of the main UART interface.

Table 9: Pin Definition of Main UART Interface

Pin Name	Pin No.	I/O	Power Domain	Description
UART_RX	11	DI	3.3V	UART receive data
UART_TX	13	DO	3.3V	UART transmit data
UART_CTS	23	DI	3.3V	UART clear to send
UART_RTS	25	DO	3.3V	UART request to send

The signal level of main UART interface is 3.3V. When connecting to the peripheral MCU/RAM, customers need to pay attention to the signal direction. The reference circuit is as follows:

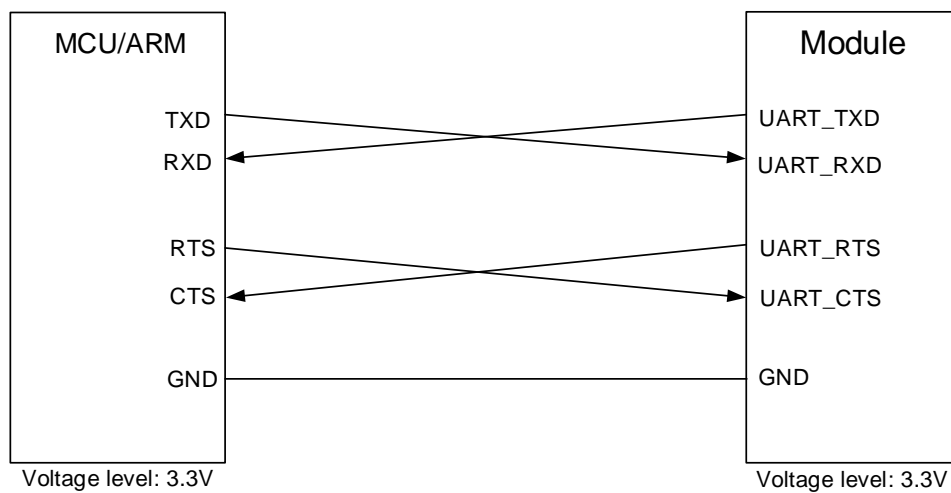

Figure 6: Reference Circuit of Power Supply

3.8.2. COEX UART Interface*

The following table shows the pin definition of the COEX UART interface.

Table 10: Pin Definition of COEX UART Interface

Pin No.	Pin Name	I/O	Power Domain	Description
3	COEX_UART_RX	DI	1.8V	LTE/WLAN&BT coexistence receive signal.

				It is prohibited to be pulled up high before startup.
5	COEX_UART_TX	DO	1.8V	LTE/WLAN&BT coexistence transmitting signal. It is prohibited to be pulled up high before startup.

NOTES

1. **AT+IPR** command can be used to set the baud rate of the main UART, and **AT+IFC** command can be used to set the hardware flow control (hardware flow control is disabled by default). Please refer to **document [2]** for details.
2. “*” means under development.

3.9. PCM and I2C Interfaces

EC25 Mini PCIe provides one Pulse Code Modulation (PCM) digital interface and one I2C interface.

The following table shows the pin definition of PCM and I2C interfaces that can be applied in audio codec design.

Table 11: Pin Definition of PCM and I2C Interfaces

Pin Name	Pin No.	I/O	Power Domain	Description
PCM_CLK	45	IO	1.8V	PCM clock signal
PCM_DOUT	47	DO	1.8V	PCM data output
PCM_DIN	49	DI	1.8V	PCM data input
PCM_SYNC	51	IO	1.8V	PCM frame synchronization
I2C_SCL	30	OD	1.8V	I2C serial clock. Require external pull-up to 1.8V.
I2C_SDA	32	OD	1.8V	I2C serial data. Require external pull-up to 1.8V.

EC25 Mini PCIe provides one PCM digital interface, which supports 16-bit linear data format and the following modes:

- Primary mode (short frame synchronization, works as either master or slave)
- Auxiliary mode (long frame synchronization, works as master only)

NOTE

The digital audio (PCM) function is only supported on **Telematics** version.

In primary mode, the data is sampled on the falling edge of the PCM_CLK and transmitted on the rising edge. The PCM_SYNC falling edge represents the MSB. In this mode, the PCM interface supports 256kHz, 512kHz, 1024kHz or 2048kHz PCM_CLK at 8kHz PCM_SYNC, and also supports 4096kHz PCM_CLK at 16kHz PCM_SYNC. The following figure shows the timing relationship in primary mode with 8kHz PCM_SYNC and 2048kHz PCM_CLK.

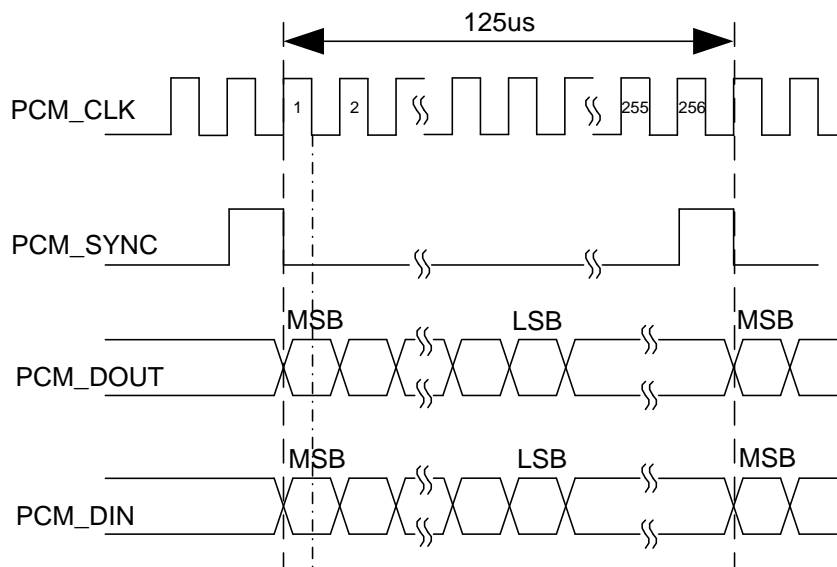

Figure 7: Timing in Primary Mode

In auxiliary mode, the data is sampled on the falling edge of the PCM_CLK and transmitted on the rising edge. The PCM_SYNC rising edge represents the MSB. In this mode, the PCM interface operates with a 256kHz, 512kHz, 1024kHz or 2048kHz PCM_CLK and an 8kHz, 50% duty cycle PCM_SYNC. The following figure shows the timing relationship in auxiliary mode with 8kHz PCM_SYNC and 256kHz PCM_CLK.

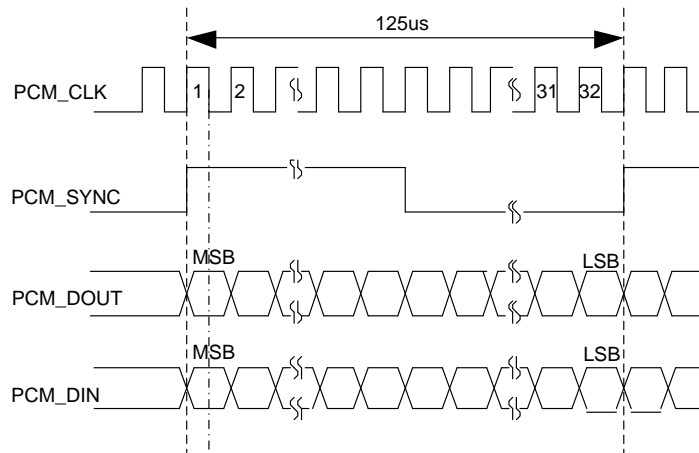

Figure 8: Timing in Auxiliary Mode

Clock and mode can be configured by AT command, and the default configuration is master mode using short frame synchronization format with 2048kHz PCM_CLK and 8kHz PCM_SYNC. In addition, EC25 Mini PCIe's firmware has integrated the configuration on some PCM codec's application with I2C interface. Please refer to **document [2]** for details about **AT+QDAI** command.

The following figure shows a reference design of PCM interface with an external codec IC.

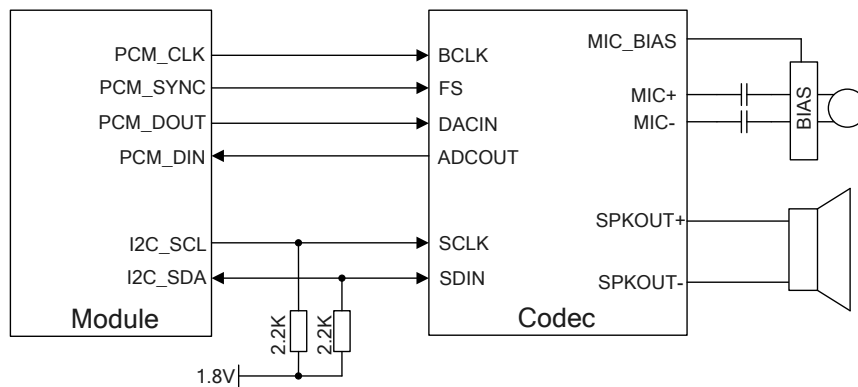

Figure 9: Reference Circuit of PCM Application with Audio Codec

NOTE

Digital audio (PCM) function is only supported on **Telematics** version.

3.10. Control and Indication Signals

The following table shows the pin definition of control and indication signals.

Table 12: Pin Definition of Control and Indication Signals

Pin Name	Pin No.	I/O	Power Domain	Description
RI	17	DO	3.3V	Output signal used to wake up the host
DTR	31	DI	3.3V	Sleep mode control
W_DISABLE#	20	DI	3.3V	Airplane mode control; Pulled up by default; Active low.
PERST#	22	DI	3.3V	Fundamental reset signal; Active low.
LED_WWAN#	42	OC		LED signal for indicating the network status of the module; Active low.
WAKE#	1	OC		Output signal to wake up the host.

3.10.1. RI Signal

The RI signal can be used to wake up the host. When a URC returns, there will be the following behaviors on the RI pin after executing `AT+QCFG="risignaltype","physical"`.

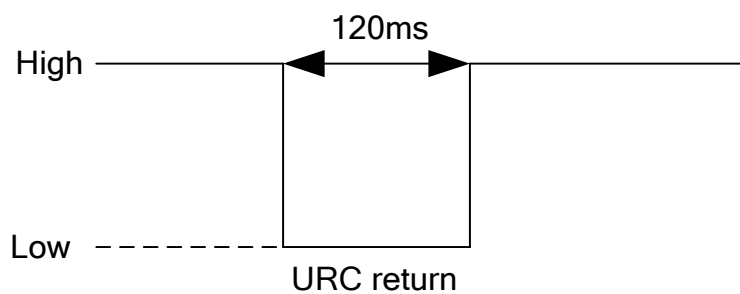

Figure 10: RI Behaviors

3.10.2. DTR Signal

The DTR signal is used for sleep mode control. It is pulled up by default. When module is in sleep mode, driving it to low level can wake up the module. For more details about the preconditions for module to enter sleep mode, please refer to **Chapter 3.4.1**.

3.10.3. W_DISABLE# Signal

EC25 Mini PCIe provides a W_DISABLE# signal to disable or enable the RF function (excluding GNSS). The W_DISABLE# pin is pulled up by default. Its control function for airplane mode is disabled by default, and **AT+QCFG="airplanecontrol",1** can be used to enable the function. Driving it to low level can make the module enter airplane mode.

The RF function can also be enabled or disabled through AT commands **AT+CFUN**, and the details are as follows.

Table 13: Airplane Mode Controlled by Hardware Method

W_DISABLE#	RF Function Status	Module Operation Mode
High level	RF enabled	Normal mode
Low level	RF disabled	Airplane mode

Software method can be controlled by **AT+CFUN**, and the details are as follows.

Table 14: Airplane Mode Controlled by Software Method

AT+CFUN=?	RF Function Status	Module Operation Mode
0	RF and (U)SIM disabled	Minimum functionality mode
1	RF enabled	Normal mode
4	RF disabled	Airplane mode

3.10.4. PERST# Signal

The PERST# signal can be used to force a hardware reset on the card. The module can be reset by driving the PERST# signal low for 150ms~460ms and then releasing it. The PERST# signal is sensitive to interference. The traces should be as short as possible and be surrounded with ground. The reset scenario is illustrated in the following figure.

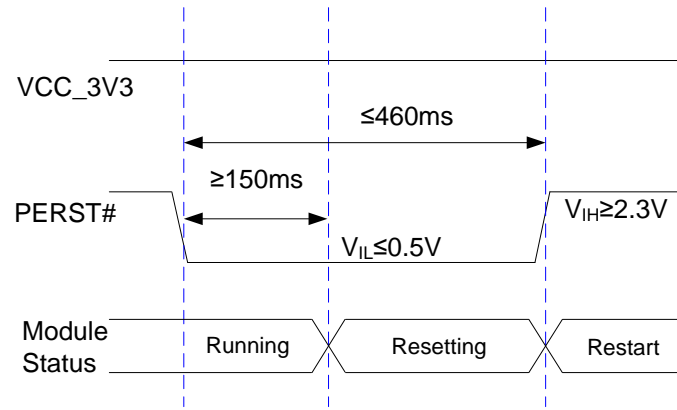

Figure 11: Timing of Resetting Module

3.10.5. LED_WWAN# Signal

The LED_WWAN# signal of EC25 Mini PCIe is used to indicate the network status of the module, and can absorb a current up to 40mA. According to the following circuit, in order to reduce the current of the LED, a resistor must be placed in series with the LED.

The LED is emitting light when the LED_WWAN# output signal is low.

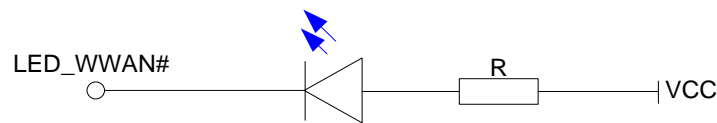

Figure 12: LED_WWAN# Signal Reference Circuit Diagram

There are two indication modes for LED_WWAN# signal to indicate network status, which can be switched through following AT commands:

- **AT+QCFG="ledmode",0 (Default setting)**
- **AT+QCFG="ledmode",2**

The following tables show the detailed network status indications of the LED_WWAN# signal.

Table 15: Indications of Network Status (AT+QCFG="ledmode",0, Default Setting)

Pin Status	Description
Flicker slowly (200ms Low/1800ms High)	Network searching
Flicker slowly (1800ms Low/200ms High)	Idle
Flicker quickly (125ms Low/125ms High)	Data transfer is ongoing
Always Low	Voice calling

Table 16: Indications of Network Status (AT+QCFG="ledmode",2)

Pin Status	Description
Low Level (Light ON)	Registered on network successfully
High Impedance (Light OFF)	<ul style="list-style-type: none"> ● No network coverage or not registered ● W_DISABLE# signal is at low level. (Disable RF) ● AT+CFUN=0, AT+CFUN=4

3.10.6. WAKE# Signal

The WAKE# signal is an open collector signal which is similar to RI signal, but a host pull-up resistor and **AT+QCFG="risignaltype", "physical"** command are required. When a URC returns, a 120ms low level pulse will be outputted. The state of WAKE# signal is shown as below.

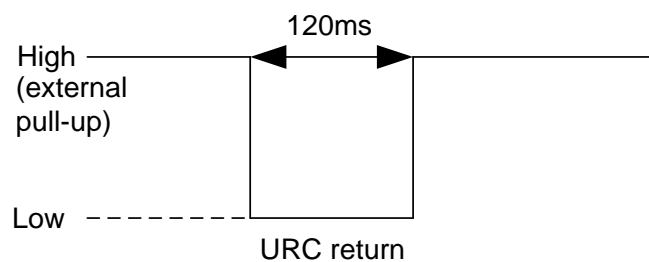

Figure 13: WAKE# Behavior

4 GNSS Receiver

4.1. General Description

EC25 Mini PCIe includes a fully integrated global navigation satellite system solution that supports Qualcomm Gen8C Lite (GPS, GLONASS, BeiDou/Compass, Galileo and QZSS). Additionally, it supports standard NMEA-0183 protocol, and outputs NMEA sentences at 1Hz data update rate via USB interface by default.

By default, EC25 Mini PCIe GNSS engine is switched off. It has to be switched on via AT command. For more details about GNSS engine technology and configurations, please refer to **document [3]**.

4.2. GNSS Performance

The following table shows the GNSS performance of EC25 Mini PCIe.

Table 17: GNSS Performance

Parameter	Description	Conditions	Typ.	Unit
Sensitivity (GNSS)	Cold start	Autonomous	-146	dBm
	Reacquisition	Autonomous	-157	dBm
	Tracking	Autonomous	-157	dBm
TTFF (GNSS)	Cold start @open sky	Autonomous	35	s
		XTRA enabled	18	s
	Warm start @open sky	Autonomous	26	s
		XTRA enabled	2.2	s
	Hot start @open sky	Autonomous	2.5	s
		XTRA enabled	1.8	s

Accuracy (GNSS)	CEP-50	Autonomous @open sky	<2.5	m
-----------------	--------	----------------------	------	---

NOTES

1. Tracking sensitivity: the minimum GNSS signal power at which the module can maintain lock (keep positioning for at least 3 minutes continuously).
2. Reacquisition sensitivity: the minimum GNSS signal power required for the module to maintain lock within 3 minutes after loss of lock.
3. Cold start sensitivity: the minimum GNSS signal power at which the module can fix position successfully within 3 minutes after executing cold start command.

4.3. GNSS Frequency

The following table shows the GNSS frequency of EC25 Mini PCIe.

Table 18: GNSS Frequency

Type	Frequency	Unit
GPS	1575.42±1.023	MHz
GLONASS	1597.5~1605.8	MHz
Galileo	1575.42±2.046	MHz
BeiDou (Compass)	1561.098±2.046	MHz
QZSS	1575.42	MHz

5 Antenna Connection

5.1. Antenna Connectors

EC25 Mini PCIe is mounted with three antenna connectors for external antenna connection: a main antenna connector, an Rx-diversity antenna connector, and a GNSS antenna connector. And Rx-diversity function is enabled by default. The impedance of the antenna connectors is 50Ω.

5.1.1. Operating Frequency

Table 19: Operating Frequencies

3GPP Band	Transmit	Receive	Unit
GSM850	824~849	869~894	MHz
EGSM900	880~915	925~960	MHz
DCS1800	1710~1785	1805~1880	MHz
PCS1900	1850~1910	1930~1990	MHz
WCDMA B1	1920~1980	2110~2170	MHz
WCDMA B2	1850~1910	1930~1990	MHz
WCDMA B4	1710~1755	2110~2155	MHz
WCDMA B5	824~849	869~894	MHz
WCDMA B6	830~840	875~885	MHz
WCDMA B8	880~915	925~960	MHz
WCDMA B19	830~845	875~890	MHz
LTE-FDD B1	1920~1980	2110~2170	MHz
LTE-FDD B2	1850~1910	1930~1990	MHz

LTE-FDD B3	1710~1785	1805~1880	MHz
LTE-FDD B4	1710~1755	2110~2155	MHz
LTE-FDD B5	824~849	869~894	MHz
LTE-FDD B7	2500~2570	2620~2690	MHz
LTE-FDD B8	880~915	925~960	MHz
LTE-FDD B12	699~716	729~746	MHz
LTE-FDD B13	777~787	746~756	MHz
LTE-FDD B14	788~798	758~768	MHz
LTE-FDD B18	815~830	860~875	MHz
LTE-FDD B19	830~845	875~890	MHz
LTE-FDD B20	832~862	791~821	MHz
LTE-FDD B26	814~849	859~894	MHz
LTE-FDD B28	703~748	758~803	MHz
LTE-TDD B38	2570~2620	2570~2620	MHz
LTE-TDD B40	2300~2400	2300~2400	MHz
LTE-TDD B41	2555~2655	2555~2655	MHz
LTE-FDD B66	1710~1780	2100~2200	MHz
LTE-FDD B71	663~698	617~652	MHz

5.2. Antenna Requirements

The following table shows the requirements on main antenna, Rx-diversity antenna and GNSS antenna.

Table 20: Antenna Requirements

Type	Requirements
GNSS ¹⁾	Frequency range: 1559MHz~1609MHz Polarization: RHCP or linear VSWR: < 2 (Typ.) Passive antenna gain: > 0dBi Active antenna noise figure: < 1.5dB Active antenna gain: > 0dBi Active antenna embedded LNA gain: < 17dB
GSM/UMTS/LTE	VSWR: ≤ 2 Efficiency: > 30% Max input power: 50W Input impedance: 50Ω Cable insertion loss: < 1dB (GSM850, EGSM900, WCDMA B5/B6/B8/B19, LTE-FDD B5/B8/B12/B13/B14/B18/B19/B20/B26/B28/B71) Cable insertion loss: < 1.5dB (DCS1800, PCS1900, WCDMA B1/B2/B4, LTE-FDD B1/B2/B3/B4/B66) Cable insertion loss: < 2dB (LTE-FDD B7, LTE-TDD B38/B40/B41)

NOTES

1. It is recommended to use a passive GNSS antenna when LTE B13 or B14 is supported, as the use of active antenna may generate harmonics which will affect the GNSS performance.
2. Since the GNSS port has a 2.85V voltage output, a passive antenna that causes shorting to GND, such as PIFA antenna is not recommended.

5.3. Recommended Mating Plugs for Antenna Connection

EC25 Mini PCIe is mounted with RF connectors (receptacles) for convenient antenna connection. The dimensions of the antenna connectors are shown as below.

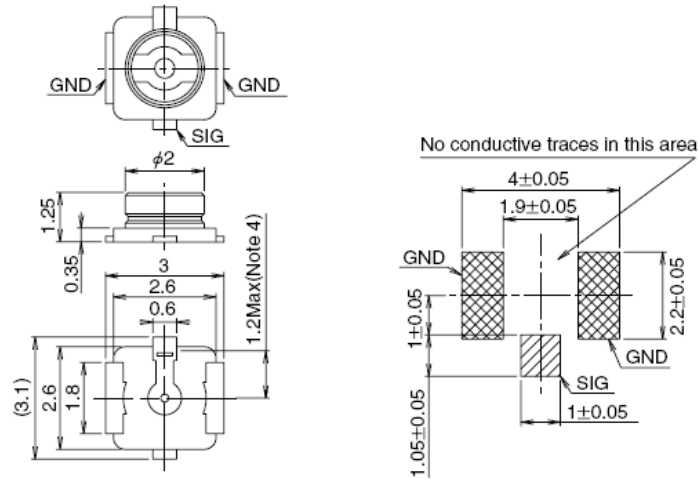

Figure 14: Dimensions of the Receptacle RF Connectors (Unit: mm)

U.FL-LP mating plugs listed in the following figure can be used to match the receptacles.

	U.FL-LP-040	U.FL-LP-066	U.FL-LP(V)-040	U.FL-LP-062	U.FL-LP-088
Part No.					
Mated Height	2.5mm Max. (2.4mm Nom.)	2.5mm Max. (2.4mm Nom.)	2.0mm Max. (1.9mm Nom.)	2.4mm Max. (2.3mm Nom.)	2.4mm Max. (2.3mm Nom.)
Applicable cable	Dia. 0.81mm Coaxial cable	Dia. 1.13mm and Dia. 1.32mm Coaxial cable	Dia. 0.81mm Coaxial cable	Dia. 1mm Coaxial cable	Dia. 1.37mm Coaxial cable
Weight (mg)	53.7	59.1	34.8	45.5	71.7
RoHS	YES				

Figure 15: Mechanicals of U.FL-LP Mating Plugs

The following figure describes the space factor of mating plugs.

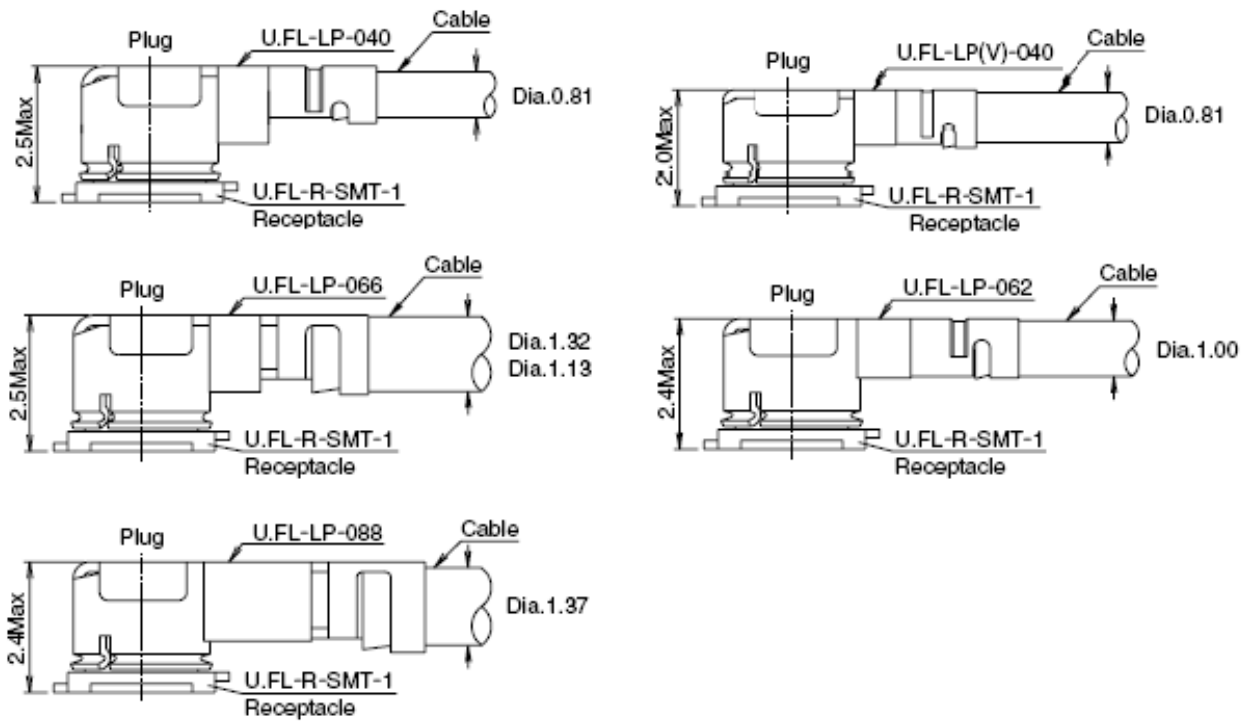

Figure 16: Space Factor of Mating Plugs (Unit: mm)

For more details of the recommended mating plugs, please visit <http://www.hirose.com>.

6 Electrical, Reliability and Radio Characteristics

6.1. General Description

This chapter mainly describes the following electrical and radio characteristics of EC25 Mini PCIe:

- Power supply requirements
- I/O requirements
- RF characteristics
- ESD characteristics
- Current consumption
- Thermal consideration

6.2. Power Supply Requirements

The input voltage of EC25 Mini PCIe is 3.0V~3.6V, as specified by *PCI Express Mini CEM Specifications 1.2*. The following table shows the power supply requirements of EC25 Mini PCIe.

Table 21: Power Supply Requirements

Parameter	Description	Min.	Typ.	Max.	Unit
VCC_3V3	Power Supply	3.0	3.3	3.6	V

6.3. I/O Requirements

The following table shows the I/O requirements of EC25 Mini PCIe.

Table 22: I/O Requirements

Parameter	Description	Min.	Max.	Unit
V _{IH}	Input High Voltage	0.7 × VCC_3V3	VCC_3V3 + 0.3	V
V _{IL}	Input Low Voltage	-0.3	0.3 × VCC_3V3	V
V _{OH}	Output High Voltage	VCC_3V3 - 0.5	VCC_3V3	V
V _{OL}	Output Low Voltage	0	0.4	V

NOTES

1. The PCM and I2C interfaces belong to 1.8V power domain and other I/O interfaces belong to VCC_3V3 power domain.
2. The maximum voltage value of V_{IL} for PERST# signal and W_DISABLE# signal is 0.5V.

6.4. RF Characteristics

The following tables show the conducted RF output power and receiving sensitivity of EC25 Mini PCIe module.

Table 23: Conducted RF Output Power of EC25 Mini PCIe

Frequency Bands	Max.	Min.
GSM850/EGSM900	33dBm±2dB	5dBm±5dB
DCS1800/PCS1900	30dBm±2dB	0dBm±5dB
GSM850/EGSM900 (8-PSK)	27dBm±3dB	5dBm±5dB
DCS1800/PCS1900 (8-PSK)	26dBm±3dB	0dBm±5dB
WCDMA bands	24dBm+1/-3dB	< -49dBm

LTE-FDD bands	23dBm±2dB	< -39dBm
LTE-TDD bands	23dBm±2dB	< -39dBm

Table 24: Conducted RF Receiving Sensitivity of EC25-A Mini PCIe

Frequency Bands	Primary	Diversity	SIMO ¹⁾	3GPP (SIMO)
WCDMA B2	-110.0dBm	/	/	-104.7dBm
WCDMA B4	-110.0dBm	/	/	-106.7dBm
WCDMA B5	-110.5dBm	/	/	-104.7dBm
LTE-FDD B2 (10MHz)	-98.0dBm	-98.0dBm	-101.0dBm	-94.3dBm
LTE-FDD B4 (10MHz)	-97.5dBm	-99.0dBm	-101.0dBm	-96.3dBm
LTE-FDD B12 (10MHz)	-97.2dBm	-98.0dBm	-101.0dBm	-93.3dBm

Table 25: Conducted RF Receiving Sensitivity of EC25-AU Mini PCIe

Frequency Bands	Primary	Diversity	SIMO ¹⁾	3GPP (SIMO)
GSM850	-109.0dBm	/	/	-102.0dBm
EGSM900	-109.0dBm	/	/	-102.0dBm
DCS1800	-109.0dBm	/	/	-102.0dBm
PCS1900	-109.0dBm	/	/	-102.0dBm
WCDMA B1	-110.0dBm	-109dBm	-112dBm	-106.7dBm
WCDMA B2	-110.0dBm	/	/	-104.7dBm
WCDMA B5	-111.0dBm	-112dBm	-113dBm	-104.7dBm
WCDMA B8	-111.0dBm	-111dBm	-113dBm	-103.7dBm
LTE-FDD B1 (10MHz)	-97.2dBm	-97.5dBm	-100.2dBm	-96.3dBm
LTE-FDD B2 (10MHz)	-98.2dBm	/	/	-94.3dBm
LTE-FDD B3 (10MHz)	-98.7dBm	-98.6dBm	-102.2dBm	-93.3dBm

LTE-FDD B4 (10MHz)	-97.7dBm	-97.4dBm	-100.2dBm	-96.3dBm
LTE-FDD B5 (10MHz)	-98.0dBm	-98.2dBm	-101.0dBm	-94.3dBm
LTE-FDD B7 (10MHz)	-97.7dBm	-97.7dBm	-101.2dBm	-94.3dBm
LTE-FDD B8 (10MHz)	-99.2dBm	-98.2dBm	-102.2dBm	-93.3dBm
LTE-FDD B28 (10MHz)	-98.6dBm	-98.7dBm	-102.0dBm	-94.8dBm
LTE-TDD B40 (10MHz)	-97.2dBm	-98.4dBm	-101.2dBm	-96.3dBm

Table 26: Conducted RF Receiving Sensitivity of EC25-J Mini PCIe

Frequency Bands	Primary	Diversity	SIMO ¹⁾	3GPP (SIMO)
WCDMA B1	-110.0dBm	/	/	-106.7dBm
WCDMA B6	-110.5dBm	/	/	-106.7dBm
WCDMA B8	-110.5dBm	/	/	-103.7dBm
WCDMA B19	-110.5dBm	/	/	-106.7dBm
LTE-FDD B1 (10MHz)	-97.5dBm	-98.7dBm	-100.2dBm	-96.3dBm
LTE-FDD B3 (10MHz)	-96.5dBm	-97.1dBm	-100.5dBm	-93.3dBm
LTE-FDD B8 (10MHz)	-98.4dBm	-99.0dBm	-101.2dBm	-93.3dBm
LTE-FDD B18 (10MHz)	-99.5dBm	-99.0dBm	-101.7dBm	-96.3dBm
LTE-FDD B19 (10MHz)	-99.2dBm	-99.0dBm	-101.4dBm	-96.3dBm
LTE-FDD B26 (10MHz)	-99.5dBm	-99.0dBm	-101.5dBm	-93.8dBm
LTE-TDD B41 (10MHz)	-95.0dBm	-95.7dBm	-99.0dBm	-94.3dBm

Table 27: Conducted RF Receiving Sensitivity of EC25-E Mini PCIe

Frequency Bands	Primary	Diversity	SIMO ¹⁾	3GPP (SIMO)
EGSM900	-109.0dBm	/	/	-102.0dBm
DCS1800	-109.0dBm	/	/	-102.0dbm

WCDMA B1	-110.5dBm	/	/	-106.7dBm
WCDMA B5	-110.5dBm	/	/	-104.7dBm
WCDMA B8	-110.5dBm	/	/	-103.7dBm
LTE-FDD B1 (10MHz)	-98.0dBm	-98.0dBm	-101.5dBm	-96.3dBm
LTE-FDD B3 (10MHz)	-96.5dBm	-98.5dBm	-101.5dBm	-93.3dBm
LTE-FDD B5 (10MHz)	-98.0dBm	-98.5dBm	-101.0dBm	-94.3dBm
LTE-FDD B7 (10MHz)	-97.0dBm	-97.0dBm	-99.5dBm	-94.3dBm
LTE-FDD B8 (10MHz)	-97.0dBm	-97.0dBm	-101.0dBm	-93.3dBm
LTE-FDD B20 (10MHz)	-97.5dBm	-99.0dBm	-102.5dBm	-93.3dBm
LTE-TDD B38 (10MHz)	-95.0dBm	-97.0dBm	-98.9dBm	-96.3dBm
LTE-TDD B40 (10MHz)	-96.3dBm	-98.0dBm	-101.0dBm	-96.3dBm
LTE-TDD B41 (10MHz)	-94.5dBm	-97.0dBm	-98.5dBm	-94.3dBm

Table 28: Conducted RF Receiving Sensitivity of EC25-V Mini PCIe

Frequency Bands	Primary	Diversity	SIMO ¹⁾	3GPP (SIMO)
LTE-FDD B4 (10MHz)	-97.5dBm	-99.0dBm	-101.0dBm	-96.3dBm
LTE-FDD B13 (10MHz)	-97.7dBm	-97.0dBm	-100.0dBm	-93.3dBm

Table 29: Conducted RF Receiving Sensitivity of EC25-AF Mini PCIe

Frequency Bands	Primary	Diversity	SIMO ¹⁾	3GPP (SIMO)
WCDMA B2	-109.5dBm	-110dBm	-110.4dBm	-104.7dBm
WCDMA B4	-109.6dBm	-110dBm	-110.6dBm	-106.7dBm
WCDMA B5	-110.5dBm	-110dBm	-110.7dBm	-104.7dBm
LTE-FDD B2 (10MHz)	-98.0dBm	-98.5dBm	-100.5dBm	-94.3dBm
LTE-FDD B4 (10MHz)	-97.5dBm	-98.2dBm	-99.5dBm	-93.3dBm

LTE-FDD B5 (10MHz)	-98.0dBm	-98.5dBm	-100.5dBm	-94.3dBm
LTE-FDD B12 (10MHz)	-99.0dBm	-99.5dBm	-100.5dBm	-93.3dBm
LTE-FDD B13 (10MHz)	-98.5dBm	-99.5dBm	-100.7dBm	-93.3dBm
LTE-FDD B14 (10MHz)	-99.4dBm	-99.5dBm	-100.9dBm	-93.3dBm
LTE-FDD B66 (10MHz)	-97.5dBm	-98.5dBm	-99.6dBm	-95.8dBm
LTE-FDD B71 (10MHz)	-98.6dBm	-99.5dBm	-100dBm	-93.5dBm

Table 30: Conducted RF Receiving Sensitivity of EC25-AFX Mini PCIe

Frequency Bands	Primary	Diversity	SIMO ¹⁾	3GPP (SIMO)
WCDMA B2	-109.6dBm	-110dBm	-110.4dBm	-104.7dBm
WCDMA B4	-109.6dBm	-110dBm	-110.6dBm	-106.7dBm
WCDMA B5	-110.5dBm	-110dBm	-110.7dBm	-104.7dBm
LTE-FDD B2 (10MHz)	-98.0dBm	-98.5dBm	-100.5dBm	-94.3dBm
LTE-FDD B4 (10MHz)	-97.6dBm	-98.2dBm	-99.5dBm	-93.3dBm
LTE-FDD B5 (10MHz)	-98.0dBm	-98.5dBm	-100.5dBm	-94.3dBm
LTE-FDD B12 (10MHz)	-99.0dBm	-99.5dBm	-100.5dBm	-93.3dBm
LTE-FDD B13 (10MHz)	-98.5dBm	-99.7dBm	-100.8dBm	-93.3dBm
LTE-FDD B14 (10MHz)	-99.4dBm	-99.5dBm	-100.9dBm	-93.3dBm
LTE-FDD B66 (10MHz)	-97.5dBm	-98.5dBm	-99.6dBm	-95.8dBm
LTE-FDD B71 (10MHz)	-98.8dBm	-99.7dBm	-100.5dBm	-93.5dBm

Table 31: Conducted RF Receiving Sensitivity of EC25-EU Mini PCIe

Frequency Bands	Primary	Diversity	SIMO ¹⁾	3GPP (SIMO)
EGSM900	-108dBm	/	/	-102.0dBm
DCS1800	-108.6dBm	/	/	-102.0dbm

WCDMA B1	-110dBm	-109dBm	/	-106.7dBm
WCDMA B8	-110dBm	-111dBm	/	-103.7dBm
LTE-FDD B1 (10MHz)	-98.2dBm	-99.0dBm	-101.2dBm	-96.3dBm
LTE-FDD B3 (10MHz)	-97.7dBm	-99.8dBm	-101.0dBm	-93.3dBm
LTE-FDD B7 (10MHz)	-96.7dBm	-98.5dBm	-100.2dBm	-94.3dBm
LTE-FDD B8 (10MHz)	-98.2dBm	-100.4dBm	-101.7 dBm	-93.3dBm
LTE-FDD B20 (10MHz)	-98.2dBm	-100.8dBm	-101.7dBm	-93.3dBm
LTE-FDD B28 (10MHz)	-98.2dBm	-100.5dBm	-101.7dBm	-94.8dBm
LTE-TDD B38 (10MHz)	-95dBm	-97.0dBm	-99.7dBm	-96.3dBm
LTE-TDD B40 (10MHz)	-95.9dBm	-98.0dBm	-100.2dBm	-96.3dBm
LTE-TDD B41 (10MHz)	-94.8dBm	-97.0dBm	-99.7dBm	-94.3dBm

Table 32: Conducted RF Receiving Sensitivity of EC25-EUX Mini PCIe

Frequency Bands	Primary	Diversity	SIMO ¹⁾	3GPP (SIMO)
EGSM900	-109.0dBm	/	/	-102.0dBm
DCS1800	-109.0dBm	/	/	-102.0dbm
WCDMA B1	-110.5dBm	/	/	-106.7dBm
WCDMA B8	-110.5dBm	/	/	-103.7dBm
LTE-FDD B1 (10MHz)	-98.0dBm	-98.0dBm	-101dBm	-96.3dBm
LTE-FDD B3 (10MHz)	-96.5dBm	-98.5dBm	-99.5dBm	-93.3dBm
LTE-FDD B7 (10MHz)	-97.0dBm	-94.5dBm	-99.5dBm	-94.3dBm
LTE-FDD B8 (10MHz)	-97.0dBm	-97.0dBm	-100.0dBm	-93.3dBm
LTE-FDD B20 (10MHz)	-97.5dBm	-99.0dBm	-101.5dBm	-93.3dBm
LTE-FDD B28 (10MHz)	-98.6dBm	-98.7dBm	-101.0dBm	-94.8dBm
LTE-TDD B38 (10MHz)	-96.3dBm	-97dBm	-98.5dBm	-96.3dBm

LTE-TDD B40 (10MHz)	-96.9dBm	-98.0dBm	-99.1dBm	-96.3dBm
LTE-TDD B41 (10MHz)	-95.3dBm	-97.5dBm	-98.0dBm	-94.3dBm

Table 33: Conducted RF Receiving Sensitivity of EC25-MX Mini PCIe

Frequency Bands	Primary	Diversity	SIMO ¹⁾	3GPP (SIMO)
WCDMA B2	-110dBm	-110dBm	/	-104.7dBm
WCDMA B4	-109.5dBm	-110dBm	/	-106.7dBm
WCDMA B5	-110dBm	-110dBm	/	-104.7dBm
LTE-FDD B2 (10MHz)	-98.2dBm	-99.1dBm	-101.5dBm	-94.3dBm
LTE-FDD B4 (10MHz)	-97.2dBm	-98.2dBm	-101.2dBm	-96.3dBm
LTE-FDD B5 (10MHz)	-98.2dBm	-99.2dBm	-102.2dBm	-94.3dBm
LTE-FDD B7 (10MHz)	-95.7dBm	-98.5dBm	-100.2dBm	-94.3dBm
LTE-FDD B28 (10MHz)	-97.2dBm	-99.3dBm	-101.7dBm	-94.8dBm
LTE-FDD B66 (10MHz)	-97.2dBm	-98.4dBm	-101.2dBm	-95.8dBm

Table 34: Conducted RF Receiving Sensitivity of EC25-AUX Mini PCIe

Frequency Bands	Primary	Diversity	SIMO ¹⁾	3GPP (SIMO)
GSM850	-109.0dBm	/	/	-102.0dBm
EGSM900	-109.0dBm	/	/	-102.0dBm
DCS1800	-109.0dBm	/	/	-102.0dBm
PCS1900	-109.0dBm	/	/	-102.0dBm
WCDMA B1	-110.0dBm	-109.5dBm	-112dBm	-106.7dBm
WCDMA B2	-110.5dBm	/	/	-104.7dBm
WCDMA B4	-110.0dBm	-110dBm	-112dBm	-104.7dBm
WCDMA B5	-111.0dBm	-112dBm	-113dBm	-104.7dBm

WCDMA B8	-111.0dBm	-112dBm	-113dBm	-103.7dBm
LTE-FDD B1 (10MHz)	-98.0dBm	-97.7dBm	-101.2dBm	-96.3dBm
LTE-FDD B2 (10MHz)	-98.5dBm	/	/	-94.3dBm
LTE-FDD B3 (10MHz)	-99.0dBm	-98.8dBm	-102.2dBm	-93.3dBm
LTE-FDD B4 (10MHz)	-97.7dBm	-97.6dBm	-100.2dBm	-96.3dBm
LTE-FDD B5 (10MHz)	-98.5dBm	-98.2dBm	-101.0dBm	-94.3dBm
LTE-FDD B7 (10MHz)	-97.7dBm	-97.7dBm	-101.2dBm	-94.3dBm
LTE-FDD B8 (10MHz)	-99.0dBm	-98.5dBm	-102.2dBm	-93.3dBm
LTE-FDD B28 (10MHz)	-98.0dBm	-98.7dBm	-101.5dBm	-94.8dBm
LTE-TDD B40 (10MHz)	-97.5dBm	-98.2dBm	-101.2dBm	-96.3dBm

Table 35: Conducted RF Receiving Sensitivity of EC25-EX Mini PCIe

Frequency Bands	Primary	Diversity	SIMO ¹⁾	3GPP (SIMO)
EGSM900	-109.0dBm	/	/	-102.0dBm
DCS1800	-109.0dBm	/	/	-102.0dbm
WCDMA B1	-110.0dBm	/	/	-106.7dBm
WCDMA B5	-110.0dBm	/	/	-104.7dBm
WCDMA B8	-110.0dBm	/	/	-103.7dBm
LTE-FDD B1 (10MHz)	-98.0dBm	/	/	-96.3dBm
LTE-FDD B3 (10MHz)	-98.2dBm	/	/	-93.3dBm
LTE-FDD B5 (10MHz)	-98.5dBm	/	/	-94.3dBm
LTE-FDD B7 (10MHz)	-95.8dBm	/	/	-94.3dBm
LTE-FDD B8 (10MHz)	-98.5dBm	/	/	-93.3dBm
LTE-FDD B20 (10MHz)	-98.0dBm	/	/	-93.3dBm
LTE-TDD B38 (10MHz)	-97.0dBm	/	/	-96.3dBm

LTE-TDD B40 (10MHz)	-96.9dBm	/	/	-96.3dBm
LTE-TDD B41 (10MHz)	-97.0dBm	/	/	-94.3dBm

Table 37: Conducted RF Receiving Sensitivity of EC25-T Mini PCIe

Frequency Bands	Primary	Diversity	SIMO ¹⁾	3GPP (SIMO)
LTE-FDD B2 (10MHz)	-98.0dBm	-98.5dBm	-99.5dBm	-94.3dBm
LTE-FDD B4 (10MHz)	-97.5dBm	-98.2dBm	-99.5dBm	-93.3dBm
LTE-FDD B5 (10MHz)	-98.0dBm	-98.5dBm	-99.5dBm	-94.3dBm
LTE-FDD B12 (10MHz)	-98.5.0dBm	-98.5dBm	-99.5dBm	-93.3dBm
LTE-FDD B66 (10MHz)	-97.5dBm	-98.5dBm	-99.6dBm	-95.8dBm
LTE-FDD B71 (10MHz)	-98.6dBm	-98.5dBm	-99.5dBm	-93.5dBm

NOTE

¹⁾ SIMO is a smart antenna technology that uses a single antenna at the transmitter side and two antennas at the receiver side, which can improve RX performance.

6.5. ESD Characteristics

The following table shows the ESD characteristics of EC25 Mini PCIe.

Table 38: ESD Characteristics of EC25 Mini PCIe

Tested Interfaces	Contact Discharge	Air Discharge	Unit
Power Supply and GND	+/-5	+/-10	kV
Antenna Interfaces	+/-4	+/-8	kV
USB Interface	+/-4	+/-8	kV
(U)SIM Interface	+/-4	+/-8	kV

Others	+/-0.5	+/-1	kV
--------	--------	------	----

6.6. Current Consumption

The following tables describe the current consumption of EC25 Mini PCIe series module.

Table 39: Current Consumption of EC25-A Mini PCIe

Parameter	Description	Conditions	Typ.	Unit
I _{VBAT}	Sleep state	AT+CFUN=0 (USB disconnected)	3.6	mA
		WCDMA PF=64 (USB disconnected)	4.4	mA
		WCDMA PF=128 (USB disconnected)	3.8	mA
		LTE-FDD PF=64 (USB disconnected)	5.9	mA
		LTE-FDD PF=128 (USB disconnected)	4.8	mA
	Idle state	WCDMA PF=64 (USB disconnected)	27.0	mA
		WCDMA PF=64 (USB connected)	40.0	mA
		LTE-FDD PF=64 (USB disconnected)	43.0	mA
		LTE-FDD PF=64 (USB connected)	59.0	mA
	WCDMA data transfer (GNSS OFF)	WCDMA B2 HSDPA @22.63dBm	764.0	mA
		WCDMA B2 HSUPA @23.19dBm	741.0	mA
		WCDMA B4 HSDPA @22.45dBm	745.0	mA
		WCDMA B4 HSUPA @22.57dBm	752.0	mA
		WCDMA B5 HSDPA @22.49dBm	616.0	mA
		WCDMA B5 HSUPA @22.43dBm	637.0	mA
LTE data transfer (GNSS OFF)	LTE-FDD B2 @22.92dBm	977.0	mA	
	LTE-FDD B4 @23.42dBm	1094.0	mA	
	LTE-FDD B12 @23.39dBm	847.0	mA	

WCDMA voice call	WCDMA B2 @23.59dBm	861.0	mA
	WCDMA B4 @23.47dBm	812.0	mA
	WCDMA B5 @23.46dBm	683.0	mA

Table 40: Current Consumption of EC25-AU Mini PCIe

Parameter	Description	Conditions	Typ.	Unit		
I _{VBAT}	Sleep state	AT+CFUN=0 (USB disconnected)	2.6	mA		
		GSM DRX=2 (USB disconnected)	4.3	mA		
		GSM DRX=9 (USB disconnected)	3.1	mA		
		WCDMA PF=64 (USB disconnected)	3.8	mA		
		WCDMA PF=128 (USB disconnected)	3.3	mA		
		LTE-FDD PF=64 (USB disconnected)	4.2	mA		
		LTE-FDD PF=128 (USB disconnected)	3.5	mA		
		LTE-TDD PF=64 (USB disconnected)	4.5	mA		
		LTE-TDD PF=128 (USB disconnected)	3.7	mA		
		Idle state	Idle state	GSM DRX=5 (USB disconnected)	22.0	mA
GSM DRX=5 (USB connected)	34.0			mA		
WCDMA PF=64 (USB disconnected)	22.0			mA		
WCDMA PF=64 (USB connected)	33.0			mA		
LTE-FDD PF=64 (USB disconnected)	29.0			mA		
LTE-FDD PF=64 (USB connected)	42.0			mA		
LTE-TDD PF=64 (USB disconnected)	30.0			mA		
LTE-TDD PF=64 (USB connected)	42.0			mA		
GPRS data transfer (GNSS OFF)	GPRS data transfer (GNSS OFF)			EGSM900 4DL/1UL @33.10dBm	385.0	mA
				EGSM900 3DL/2UL @32.93dBm	631.0	mA

	EGSM900 2DL/3UL @31.15dBm	730.0	mA
	EGSM900 1DL/4UL @29.94dBm	830.0	mA
	DCS1800 4DL/1UL @30.35dBm	255.0	mA
	DCS1800 3DL/2UL @30.25dBm	392.0	mA
	DCS1800 2DL/3UL @30.18dBm	527.0	mA
	DCS1800 1DL/4UL @29.93dBm	667.0	mA
	GSM850 1UL/4DL @32.53dBm	232.0	mA
	GSM850 2UL/3DL @32.34dBm	384.0	mA
	GSM850 3UL/2DL @30.28dBm	441.0	mA
	GSM850 4UL/1DL @29.09dBm	511.0	mA
	PCS1900 1UL/4DL @29.61dBm	174.0	mA
	PCS1900 2UL/3DL @29.48dBm	273.0	mA
	PCS1900 3UL/2DL @29.32dBm	367.0	mA
	PCS1900 4UL/1DL @29.19dBm	465.0	mA
	EGSM900 4DL/1UL @27.54dBm	264.0	mA
	EGSM900 3DL/2UL @27.38dBm	368.0	mA
	EGSM900 2DL/3UL @27.27dBm	498.0	mA
	EGSM900 1DL/4UL @27.17dBm	634.0	mA
	DCS1800 4DL/1UL @27.64dBm	223.0	mA
	DCS1800 3DL/2UL @27.45dBm	333.0	mA
	DCS1800 2DL/3UL @27.34dBm	449.0	mA
	DCS1800 1DL/4UL @27.29dBm	573.0	mA
	GSM850 1UL/4DL @27.09dBm	154.0	mA
	GSM850 2UL/3DL @26.94dBm	245.0	mA
	GSM850 3UL/2DL @26.64dBm	328.0	mA
EDGE data transfer (GNSS OFF)			

	GSM850 4UL/1DL @26.53dBm	416.0	mA
	PCS1900 1UL/4DL @25.65dBm	148.0	mA
	PCS1900 2UL/3DL @25.63dBm	232.0	mA
	PCS1900 3UL/2DL @25.54dBm	313.0	mA
	PCS1900 4UL/1DL @25.26dBm	401.0	mA
	WCDMA B1 HSDPA @22.45dBm	815.0	mA
	WCDMA B1 HSUPA @21.75dBm	804.0	mA
	WCDMA B2 HSDPA @22.51dBm	610.0	mA
WCDMA data transfer (GNSS OFF)	WCDMA B2 HSUPA @22.14dBm	594.0	mA
	WCDMA B5 HSDPA @22.41dBm	755.0	mA
	WCDMA B5 HSUPA @22.13dBm	775.0	mA
	WCDMA B8 HSDPA @21.34dBm	619.0	mA
	WCDMA B8 HSUPA @21.07dBm	634.0	mA
	LTE-FDD B1 @23.28dBm	817.0	mA
	LTE-FDD B2 @23.34dBm	803.0	mA
	LTE-FDD B3 @23.2dBm	785.0	mA
LTE data transfer (GNSS OFF)	LTE-FDD B4 @22.9dBm	774.0	mA
	LTE-FDD B5 @23.45dBm	687.0	mA
	LTE-FDD B7 @22.84dBm	843.0	mA
	LTE-FDD B8 @22.92dBm	689.0	mA
	LTE-FDD B28 @23.23dBm	804.0	mA
	LTE-TDD B40 @23.3dBm	429.0	mA
GSM voice call	GSM850 PCL5 @32.66dBm	228.0	mA
	EGSM900 PCL5 @32.59dBm	235.0	mA
	DCS1800 PCL0 @29.72dBm	178.0	mA

	PCS1900 PCL0 @29.82dBm	170.0	mA
	WCDMA B1 @23.27dBm	687.0	mA
WCDMA voice call	WCDMA B2 @23.38dBm	668.0	mA
	WCDMA B5 @23.38dBm	592.0	mA
	WCDMA B8 @23.32dBm	595.0	mA

Table 41: Current Consumption of EC25-J Mini PCIe

Parameter	Description	Conditions	Typ.	Unit
I _{BAT}	Sleep state	AT+CFUN=0 (USB disconnected)	3.2	mA
		WCDMA PF=64 (USB disconnected)	4.3	mA
		WCDMA PF=128 (USB disconnected)	3.8	mA
		LTE-FDD PF=64 (USB disconnected)	5.0	mA
		LTE-FDD PF=128 (USB disconnected)	4.4	mA
		LTE-TDD PF=64 (USB disconnected)	5.1	mA
		LTE-TDD PF=128 (USB disconnected)	4.4	mA
		Idle state	WCDMA PF=64 (USB disconnected)	31.5
	WCDMA PF=64 (USB connected)		43.5	mA
	LTE-FDD PF=64 (USB disconnected)		32.3	mA
	LTE-FDD PF=64 (USB connected)		45.4	mA
	LTE-TDD PF=64 (USB disconnected)		32.3	mA
	LTE-TDD PF=64 (USB connected)		43.3	mA
	WCDMA data transfer (GNSS OFF)	WCDMA B1 HSDPA @22.55dBm	829.0	mA
WCDMA B1 HSUPA @22.25dBm		848.2	mA	
WCDMA B6 HSDPA @22.79dBm		649.2	mA	
WCDMA B6 HSUPA @22.59dBm		661.4	mA	

	WCDMA B8 HSDPA @22.71dBm	691.0	mA
	WCDMA B8 HSUPA @22.63dBm	700.0	mA
	WCDMA B19 HSDPA @22.77dBm	644.2	mA
	WCDMA B19 HSUPA @22.53dBm	657.6	mA
LTE data transfer (GNSS OFF)	LTE-FDD B1 @23.15dBm	1045.0	mA
	LTE-FDD B3 @23.29dBm	1070.0	mA
	LTE-FDD B8 @23.29dBm	867.3	mA
	LTE-FDD B18 @23.82dBm	947.7	mA
	LTE-FDD B19 @23.78dBm	955.1	mA
	LTE-FDD B26 @23.22dBm	924.9	mA
	LTE-TDD B41 @22.95dBm	609.6	mA
WCDMA voice call	WCDMA B1 @23.39dBm	969.6	mA
	WCDMA B6 @23.36dBm	692.3	mA
	WCDMA B8 @23.54dBm	763.9	mA
	WCDMA B19 @23.29dBm	682.1	mA

Table 42: Current Consumption of EC25-E Mini PCIe

Parameter	Description	Conditions	Typ.	Unit
I _{VBAT}	Sleep state	AT+CFUN=0 (USB disconnected)	3.9	mA
		GSM DRX=2 (USB disconnected)	5.1	mA
		GSM DRX=9 (USB disconnected)	4.3	mA
		WCDMA PF=64 (USB disconnected)	5.5	mA
		WCDMA PF=128 (USB disconnected)	4.8	mA
		LTE-FDD PF=64 (USB disconnected)	5.8	mA
		LTE-FDD PF=128 (USB disconnected)	5.0	mA

	LTE-TDD PF=64 (USB disconnected)	5.8	mA	
	LTE-TDD PF=128 (USB disconnected)	4.9	mA	
Idle state	GSM DRX=5 (USB disconnected)	30.0	mA	
	GSM DRX=5 (USB connected)	43.0	mA	
	WCDMA PF=64 (USB disconnected)	31.0	mA	
	WCDMA PF=64 (USB connected)	45.0	mA	
	LTE-FDD PF=64 (USB disconnected)	31.0	mA	
	LTE-FDD PF=64 (USB connected)	44.0	mA	
	LTE-TDD PF=64 (USB disconnected)	32.0	mA	
	LTE-TDD PF=64 (USB connected)	44.0	mA	
	GPRS data transfer (GNSS OFF)	EGSM900 4DL/1UL @33.08dBm	372.0	mA
		EGSM900 3DL/2UL @31.03dBm	626.0	mA
EGSM900 2DL/3UL @29.86dBm		706.0	mA	
EGSM900 1DL/4UL @29.44dBm		767.0	mA	
DCS1800 4DL/1UL @30.39dBm		262.0	mA	
DCS1800 3DL/2UL @30.19dBm		417.0	mA	
DCS1800 2DL/3UL @30.02dBm		564.0	mA	
DCS1800 1DL/4UL @29.86dBm		709.0	mA	
EDGE data transfer (GNSS OFF)	EGSM900 4DL/1UL @27.59dBm	233.0	mA	
	EGSM900 3DL/2UL @27.45dBm	370.0	mA	
	EGSM900 2DL/3UL @27.31dBm	500.0	mA	
	EGSM900 1DL/4UL @27.14dBm	623.0	mA	
	DCS1800 4DL/1UL @26.24dBm	224.0	mA	
	DCS1800 3DL/2UL @26.13dBm	334.0	mA	
	DCS1800 2DL/3UL @25.97dBm	440.0	mA	

	DCS1800 1DL/4UL @25.82dBm	553.0	mA
	WCDMA B1 HSDPA @22.49dBm	798.0	mA
	WCDMA B1 HSUPA @21.87dBm	788.0	mA
WCDMA data transfer (GNSS OFF)	WCDMA B5 HSDPA @22.66dBm	781.0	mA
	WCDMA B5 HSUPA @21.99dBm	770.0	mA
	WCDMA B8 HSDPA @22.23dBm	655.0	mA
	WCDMA B8 HSUPA @21.68dBm	659.0	mA
LTE data transfer (GNSS OFF)	LTE-FDD B1 @23.12dBm	940.0	mA
	LTE-FDD B3 @22.75dBm	989.0	mA
	LTE-FDD B5 @22.92dBm	962.0	mA
	LTE-FDD B7 @23.42dBm	1188.0	mA
	LTE-FDD B8 @22.97dBm	911.0	mA
	LTE-FDD B20 @22.51dBm	946.0	mA
	LTE-TDD B38 @22.58dBm	686.0	mA
	LTE-TDD B40 @22.31dBm	576.0	mA
	LTE-TDD B41 @22.03dBm	611.0	mA
GSM voice call	EGSM900 PCL=5 @33.31dBm	367.0	mA
	DCS1800 PCL=0 @29.48dBm	248.0	mA
WCDMA voice call	WCDMA B1 @23.18dBm	868.0	mA
	WCDMA B5 @22.62dBm	808.0	mA
	WCDMA B8 @23.02dBm	728.0	mA

Table 43: Current Consumption of EC25-T Mini PCIe

Parameter	Description	Conditions	Typ.	Unit
I _{BAT}	Sleep state	AT+CFUN=0 (USB disconnected)	1.7	mA

	AT+CFUN=0 (USB suspend)	1.9	mA
	AT+CFUN=4 (USB disconnected)	1.8	mA
	AT+CFUN=4 (USB suspend)	2.0	mA
	LTE-FDD PF=32 (USB disconnected)	5.0	mA
	LTE-FDD PF=64 (USB disconnected)	3.4	mA
	LTE-FDD PF=64 (USB suspend)	3.7	mA
	LTE-FDD PF=128 (USB disconnected)	2.8	mA
	LTE-FDD PF=256 (USB disconnected)	2.4	mA
Idle state	LTE-FDD PF=64 (USB disconnected)	25.9	mA
	LTE-FDD PF=64 (USB active)	37.7	mA
LTE data transfer (GNSS OFF)	LTE-FDD B2 @23.82dBm	839.6	mA
	LTE-FDD B4 @23.28dBm	883.0	mA
	LTE-FDD B5 @23.82dBm	742.2	mA
	LTE-FDD B12 @23.69dBm	814.3	mA
	LTE-FDD B66 @23.57dBm	956.5	mA
	LTE-FDD B71 @22.95dBm	788.3	mA

Table 44: Current Consumption of EC25-V Mini PCIe

Parameter	Description	Conditions	Typ.	Unit
I _{BAT}	Sleep state	AT+CFUN=0 (USB disconnected)	3.4	mA
		LTE-FDD PF=64 (USB disconnected)	4.8	mA
		LTE-FDD PF=128 (USB disconnected)	4.3	mA
	Idle state	LTE-FDD PF=64 (USB disconnected)	30.0	mA
		LTE-FDD PF=64 (USB connected)	42.0	mA
	LTE data	LTE-FDD B4 @23.3dBm	873.0	mA

transfer (GNSS OFF)	LTE-FDD B13 @22.13dBm	638.0	mA
------------------------	-----------------------	-------	----

Table 45: Current Consumption of EC25-AF Mini PCIe

Parameter	Description	Conditions	Typ.	Unit
	Sleep state	AT+CFUN=0 (USB disconnected)	2.2	mA
		WCDMA PF=64 (USB disconnected)	3.1	mA
		WCDMA PF=128 (USB disconnected)	2.8	mA
		LTE-FDD PF=64 (USB disconnected)	3.7	mA
		LTE-FDD PF=128 (USB disconnected)	3.1	mA
	Idle state	WCDMA PF=64 (USB disconnected)	21.7	mA
		WCDMA PF=64 (USB connected)	32.5	mA
		LTE-FDD PF=64 (USB disconnected)	25.0	mA
		LTE-FDD PF=64 (USB connected)	38.0	mA
	I _{BAT}	WCDMA data transfer (GNSS OFF)	WCDMA B2 HSDPA @22.63dBm	560.0
WCDMA B2 HSUPA @22.49dBm			564.0	mA
WCDMA B4 HSDPA @22.45dBm			601.0	mA
WCDMA B4 HSUPA @22.57dBm			610.0	mA
WCDMA B5 HSDPA @22.49dBm			603.0	mA
WCDMA B5 HSUPA @22.43dBm			617.0	mA
LTE data transfer (GNSS OFF)		LTE-FDD B2 @22.92dBm	758.0	mA
		LTE-FDD B4 @23.12dBm	770.0	mA
		LTE-FDD B5 @22.98dBm	700.0	mA
		LTE-FDD B12 @23.42dBm	808.0	mA
		LTE-FDD B13 @22.92dBm	790.0	mA
		LTE-FDD B14 @23.42dBm	795.0	mA

	LTE-FDD B66 @23.35dBm	816.0	mA
	LTE-FDD B71 @23.39dBm	801.0	mA
WCDMA voice call	WCDMA B2 @23.59dBm	585.0	mA
	WCDMA B4 @23.47dBm	610.0	mA
	WCDMA B5 @23.46dBm	605.0	mA

Table 46: Current Consumption of EC25-EUX Mini PCIe

Parameter	Description	Conditions	Typ.	Unit
I _{VBAT}	Sleep state	AT+CFUN=0 (USB disconnected)	1.69	mA
		GSM DRX=2 (USB disconnected)	2.59	mA
		GSM DRX=9 (USB disconnected)	1.97	mA
		WCDMA PF=64 (USB disconnected)	2.52	mA
		WCDMA PF=128 (USB disconnected)	2.25	mA
		LTE-FDD PF=64 (USB disconnected)	3.01	mA
		LTE-FDD PF=128 (USB disconnected)	2.4	mA
		LTE-TDD PF=64 (USB disconnected)	3.08	mA
	LTE-TDD PF=128 (USB disconnected)	2.46	mA	
	Idle state	GSM DRX=5 (USB disconnected)	18.51	mA
		GSM DRX=5 (USB connected)	37.56	mA
		WCDMA PF=64 (USB disconnected)	20.5	mA
		WCDMA PF=64 (USB connected)	38.42	mA
		LTE-FDD PF=64 (USB disconnected)	19.29	mA
LTE-FDD PF=64 (USB connected)		38.46	mA	

	LTE-TDD PF=64 (USB disconnected)	19.41	mA
	LTE-TDD PF=64 (USB connected)	37.21	mA
	EGSM900 4DL/1UL @32.5dBm	293.0	mA
	EGSM900 3DL/2UL @31.56dBm	464.0	mA
	EGSM900 2DL/3UL @29.63dBm	534.5	mA
GPRS data transfer (GNSS OFF)	EGSM900 1DL/4UL @28.76dBm	644.6	mA
	DCS1800 4DL/1UL @29.06dBm	182.5	mA
	DCS1800 3DL/2UL @28.33dBm	283.4	mA
	DCS1800 2DL/3UL @26.88dBm	368.3	mA
	DCS1800 1DL/4UL @25.74dBm	455.8	mA
	EGSM900 4DL/1UL @25.54dBm	200.1	mA
	EGSM900 3DL/2UL @25.41dBm	343.4	mA
	EGSM900 2DL/3UL @23.51dBm	471.5	mA
EDGE data transfer (GNSS OFF)	EGSM900 1DL/4UL @22.94dBm	607.8	mA
	DCS1800 4DL/1UL @25.05dBm	183.1	mA
	DCS1800 3DL/2UL @25.07dBm	291.0	mA
	DCS1800 2DL/3UL @22.54dBm	392.0	mA
	DCS1800 1DL/4UL @21.92dBm	502.2	mA
WCDMA data transfer (GNSS OFF)	WCDMA B1 HSDPA @21.72dBm	681.1	mA
	WCDMA B1 HSUPA @21.52dBm	728.0	mA
	WCDMA B8 HSDPA @21.87dBm	638.0	mA
	WCDMA B8 HSUPA @20.79dBm	636.0	mA
LTE data transfer (GNSS OFF)	LTE-FDD B1 @20.81dBm	879.0	mA
	LTE-FDD B3 @20.73dBm	955.4	mA
	LTE-FDD B7 @20.04dBm	970.8	mA

	LTE-FDD B8 @21.05dBm	815.3	mA
	LTE-FDD B20 @21.01dBm	952.1	mA
	LTE-FDD B28A @20.92dBm	1007.0	mA
	LTE-TDD B38 @20.65dBm	458.3	mA
	LTE-TDD B40 @20.52dBm	409.0	mA
	LTE-TDD B41 @20.64dBm	451.4	mA
GSM voice call	EGSM900 PCL=5 @32.17dBm	276.9	mA
	DCS1800 PCL=0 @29.09dBm	174.3	mA
WCDMA voice call	WCDMA B1 @22.64dBm	762.1	mA
	WCDMA B8 @22.17dBm	689.3	mA

Table 47: Current Consumption of EC25-AFX Mini PCIe

Parameter	Description	Conditions	Typ.	Unit
I _V BAT	Sleep state	AT+CFUN=0 (USB disconnected)	1.67	mA
		WCDMA PF=64 (USB disconnected)	2.51	mA
		WCDMA PF=64 (USB connected)	2.93	mA
		WCDMA PF=128 (USB disconnected)	2.16	mA
		WCDMA PF=256 (USB disconnected)	2.07	mA
		WCDMA PF=512 (USB disconnected)	1.88	mA
		LTE-FDD PF=32 (USB disconnected)	4.29	mA
		LTE-FDD PF=64 (USB disconnected)	3.04	mA
		LTE-FDD PF=64 (USB connected)	3.23	mA
		LTE-FDD PF=128 (USB disconnected)	2.39	mA
		LTE-FDD PF=256 (USB disconnected)	2.06	mA
Idle state	WCDMA PF=64 (USB disconnected)	22.0	mA	

		WCDMA PF=64 (USB connected)	43.0	mA
		LTE-FDD PF=64 (USB disconnected)	22.0	mA
		LTE-FDD PF=64 (USB connected)	42.8	mA
		WCDMA B2 HSDPA @22.45dBm	691.0	mA
		WCDMA B2 HSUPA @22.23dBm	605.0	mA
WCDMA data transfer (GNSS OFF)		WCDMA B4 HSDPA @22.42dBm	628.0	mA
		WCDMA B4 HSUPA @22.11dBm	630.0	mA
		WCDMA B5 HSDPA @22.02dBm	618.0	mA
		WCDMA B5 HSUPA @22.10dBm	634.0	mA
		LTE-FDD B2 @23.01dBm	743.0	mA
		LTE-FDD B4 @22.58dBm	816.0	mA
		LTE-FDD B5 @23.2dBm	751.0	mA
LTE data transfer (GNSS OFF)		LTE-FDD B12 @22.94dBm	825.0	mA
		LTE-FDD B13 @23.18dBm	815.0	mA
		LTE-FDD B14 @23.44dBm	849.0	mA
		LTE-FDD B66 @23.2dBm	850.0	mA
		LTE-FDD B71 @22.82dBm	788.0	mA
WCDMA voice call		WCDMA B2 @23.27dBm	672.0	mA
		WCDMA B4 @23.22dBm	663.0	mA
		WCDMA B5 @23.02dBm	680.0	mA

Table 48: Current Consumption of EC25-MX Mini PCIe

Parameter	Description	Conditions	Typ.	Unit
I _{BAT}	Sleep state	AT+CFUN=0 (USB disconnected)	1.55	mA
		WCDMA PF=64 (USB disconnected)	2.82	mA

	WCDMA PF=64 (USB connected)	2.98	mA
	WCDMA PF=128 (USB disconnected)	2.33	mA
	WCDMA PF=256 (USB disconnected)	2.13	mA
	WCDMA PF=512 (USB disconnected)	1.97	mA
	LTE-FDD PF=32 (USB disconnected)	4.36	mA
	LTE-FDD PF=64 (USB disconnected)	3.14	mA
	LTE-FDD PF=64 (USB connected)	3.33	mA
	LTE-FDD PF=128 (USB disconnected)	2.55	mA
	LTE-FDD PF=256 (USB disconnected)	2.38	mA
Idle state	WCDMA PF=64 (USB disconnected)	20.0	mA
	WCDMA PF=64 (USB connected)	41.1	mA
	LTE-FDD PF=64 (USB disconnected)	20.5	mA
	LTE-FDD PF=64 (USB connected)	40.7	mA
WCDMA data transfer (GNSS OFF)	WCDMA B2 HSDPA @22.75dBm	848.0	mA
	WCDMA B2 HSUPA @22.3dBm	818.0	mA
	WCDMA B4 HSDPA @23.34dBm	813.0	mA
	WCDMA B4 HSUPA @23.11dBm	774.0	mA
	WCDMA B5 HSDPA @22.53dBm	759.0	mA
	WCDMA B5 HSUPA @22.58dBm	717.0	mA
LTE data transfer (GNSS OFF)	LTE-FDD B2 @23.09dBm	918.0	mA
	LTE-FDD B4 @23.12dBm	933.0	mA
	LTE-FDD B5 @22.28dBm	706.0	mA
	LTE-FDD B7 @22.56dBm	1011.0	mA
	LTE-FDD B28 @22.41dBm	793.0	mA
	LTE-FDD B66 @23.94dBm	937.0	mA

WCDMA voice call	WCDMA B2 @23.97dBm	967.0	mA
	WCDMA B4 @23.92dBm	825.0	mA
	WCDMA B5 @23.00dBm	844.0	mA

Table 49: Current Consumption of EC25-AUX Mini PCIe

Parameter	Description	Conditions	Typ.	Unit
I _{VBAT}	Sleep state	AT+CFUN=0 (USB disconnected)	1.9	mA
		GSM DRX=2 (USB disconnected)	2.9	mA
		GSM DRX=9 (USB disconnected)	2.4	mA
		WCDMA PF=64 (USB disconnected)	3.8	mA
		WCDMA PF=128 (USB disconnected)	3.4	mA
		LTE-FDD PF=64 (USB disconnected)	4.5	mA
		LTE-FDD PF=128 (USB disconnected)	3.9	mA
		LTE-TDD PF=64 (USB disconnected)	4.5	mA
		LTE-TDD PF=128 (USB disconnected)	3.7	mA
		Idle state		GSM DRX=5 (USB disconnected)
GSM DRX=5 (USB connected)	43.4			mA
WCDMA PF=64 (USB disconnected)	24.2			mA
WCDMA PF=64 (USB connected)	45.6			mA
LTE-FDD PF=64 (USB disconnected)	28.7			mA
LTE-FDD PF=64 (USB connected)	43.7			mA
LTE-TDD PF=64 (USB disconnected)	30.4			mA
LTE-TDD PF=64 (USB connected)	43.9			mA
GPRS data transfer (GNSS OFF)		GSM850 4DL/1UL @32.88dBm	368.0	mA
		GSM850 3DL/2UL @31.99dBm	565.5	mA

	GSM850 2DL/3UL @29.94dBm	636.7	mA
	GSM850 1DL/4UL @28.73dBm	733.7	mA
	EGSM900 4DL/1UL @33.75dBm	419.3	mA
	EGSM900 3DL/2UL @32.18dBm	591.5	mA
	EGSM900 2DL/3UL @29.90dBm	631.4	mA
	EGSM900 1DL/4UL @28.70dBm	725.3	mA
	DCS1800 4DL/1UL @30.02dBm	221.8	mA
	DCS1800 3DL/2UL @29.12dBm	319.6	mA
	DCS1800 2DL/3UL @26.98dBm	384.8	mA
	DCS1800 1DL/4UL @25.80dBm	468.3	mA
	PCS1900 4DL/1UL @30.22dBm	243.2	mA
	PCS1900 3DL/2UL @28.93dBm	336.9	mA
	PCS1900 2DL/3UL @27.00dBm	398.3	mA
	PCS1900 1DL/4UL @25.86dBm	478.0	mA
	GSM850 4DL/1UL @27.45dBm	253.6	mA
	GSM850 3DL/2UL @26.29dBm	389.8	mA
	GSM850 2DL/3UL @23.96dBm	515.4	mA
	GSM850 1DL/4UL @22.72dBm	647.6	mA
EDGE data transfer (GNSS OFF)	EGSM900 4DL/1UL @27.63dBm	257.2	mA
	EGSM900 3DL/2UL @26.45dBm	399.1	mA
	EGSM900 2DL/3UL @24.27dBm	515.3	mA
	EGSM900 1DL/4UL @22.99dBm	642.0	mA
	DCS1800 4DL/1UL @26.55dBm	196.7	mA
	DCS1800 3DL/2UL @25.90dBm	304.4	mA
	DCS1800 2DL/3UL @23.91dBm	408.8	mA

	DCS1800 1DL/4UL @22.61dBm	524.3	mA
	PCS1900 4DL/1UL @26.67dBm	194.7	mA
	PCS1900 3DL/2UL @25.88dBm	299.1	mA
	PCS1900 2DL/3UL @23.85dBm	399.7	mA
	PCS1900 1DL/4UL @22.73dBm	510.1	mA
	WCDMA B1 HSDPA @21.54dBm	679.4	mA
	WCDMA B1 HSUPA @21.82dBm	721.1	mA
	WCDMA B2 HSDPA @22.10dBm	723.0	mA
WCDMA data transfer (GNSS OFF)	WCDMA B2 HSUPA @21.84dBm	708.6	mA
	WCDMA B5 HSDPA @23.27dBm	672.6	mA
	WCDMA B5 HSUPA @22.93dBm	672.0	mA
	WCDMA B8 HSDPA @21.70dBm	667.9	mA
	WCDMA B8 HSUPA @21.12dBm	674.5	mA
	LTE-FDD B1 @23.50dBm	963.9	mA
	LTE-FDD B2 @22.95dBm	941.7	mA
	LTE-FDD B3 @23.27dBm	856.4	mA
LTE data transfer (GNSS OFF)	LTE-FDD B4 @23.28dBm	817.1	mA
	LTE-FDD B5 @23.09dBm	724.5	mA
	LTE-FDD B7 @23.09dBm	945.2	mA
	LTE-FDD B8 @23.64dBm	888.3	mA
	LTE-FDD B28 @22.79dBm	964.5	mA
	LTE-TDD B40 @23.70dBm	428.9	mA
GSM voice call	GSM850 PCL5 @32.75dBm	346.9	mA
	EGSM900 PCL5 @33.53dBm	385.3	mA
	DCS1800 PCL0 @30.03dBm	210.2	mA

	PCS1900 PCL0 @29.94dBm	219.6	mA
	WCDMA B1 @23.75dBm	785.1	mA
WCDMA voice call	WCDMA B2 @23.07dBm	804.5	mA
	WCDMA B5 @23.31dBm	701.8	mA
	WCDMA B8 @22.65dBm	739.7	mA

Table 50: Current Consumption of EC25-EU Mini PCIe

Parameter	Description	Conditions	Typ.	Unit
I _{BAT}	Sleep state	AT+CFUN=0 (USB disconnected)	3.4	mA
		GSM DRX=2 (USB disconnected)	5.2	mA
		GSM DRX=9 (USB disconnected)	4.1	mA
		WCDMA PF=64 (USB disconnected)	4.9	mA
		WCDMA PF=128 (USB disconnected)	4.4	mA
		LTE-FDD PF=64 (USB disconnected)	5.3	mA
		LTE-FDD PF=128 (USB disconnected)	4.6	mA
		LTE-TDD PF=64 (USB disconnected)	5.3	mA
	LTE-TDD PF=128 (USB disconnected)	4.5	mA	
	Idle state	GSM DRX=5 (USB disconnected)	23.3	mA
		GSM DRX=5 (USB connected)	35.4	mA
		WCDMA PF=64 (USB disconnected)	23.9	mA
		WCDMA PF=64 (USB connected)	36.3	mA
		LTE-FDD PF=64 (USB disconnected)	24.1	mA
		LTE-FDD PF=64 (USB connected)	36.4	mA
		LTE-TDD PF=64 (USB disconnected)	24.1	mA

	LTE-TDD PF=64 (USB connected)	36.3	mA
	EGSM900 4DL/1UL @32.54dBm	379.0	mA
	EGSM900 3DL/2UL @31.96dBm	610.0	mA
	EGSM900 2DL/3UL @29.59dBm	654.0	mA
GPRS data transfer (GNSS OFF)	EGSM900 1DL/4UL @28.34dBm	734.0	mA
	DCS1800 4DL/1UL @29.63dBm	236.0	mA
	DCS1800 3DL/2UL @28.59dBm	343.0	mA
	DCS1800 2DL/3UL @26.62dBm	413.0	mA
	DCS1800 1DL/4UL @25.29dBm	498.0	mA
	EGSM900 4DL/1UL @27.51dBm	234.0	mA
	EGSM900 3DL/2UL @27.23dBm	372.0	mA
	EGSM900 2DL/3UL @27.08dBm	501.0	mA
EDGE data transfer (GNSS OFF)	EGSM900 1DL/4UL @26.81dBm	628.0	mA
	DCS1800 4DL/1UL @26.29dBm	199.0	mA
	DCS1800 3DL/2UL @26.18dBm	309.0	mA
	DCS1800 2DL/3UL @26.05dBm	415.0	mA
	DCS1800 1DL/4UL @25.35dBm	503.0	mA
WCDMA data transfer (GNSS OFF)	WCDMA B1 HSDPA @22.01dBm	755.0	mA
	WCDMA B1 HSUPA @22.79dBm	776.0	mA
	WCDMA B8 HSDPA @22.21dBm	670.6	mA
	WCDMA B8 HSUPA @22.04dBm	692.6	mA
LTE data transfer (GNSS OFF)	LTE-FDD B1 @23.63dBm	918.7	mA
	LTE-FDD B3 @22.78dBm	914.0	mA
	LTE-FDD B7 @22.31dBm	985.2	mA
	LTE-FDD B8 @23.35dBm	886.5	mA

	LTE-FDD B20 @22.71dBm	909.1	mA
	LTE-FDD B28A @21.79dBm	898.1	mA
	LTE-TDD B38 @22.85dBm	587.8	mA
	LTE-TDD B40 @22.96dBm	460.6	mA
	LTE-TDD B41 @22.69dBm	571.2	mA
GSM voice call	EGSM900 PCL=5 @32.80dBm	370.0	mA
	DCS1800 PCL=0 @29.51dBm	221.0	mA
WCDMA voice call	WCDMA B1 @22.96dBm	829.5	mA
	WCDMA B8 @23.21dBm	752.9	mA

Table 51: GNSS Current Consumption of EC25 Mini PCIe Series Module

Parameter	Description	Conditions	Typ.	Unit
I _{BAT} (GNSS)	Searching (AT+CFUN=0)	Cold start @Passive Antenna	75.0	mA
		Lost state @Passive Antenna	74.0	mA
	Tracking (AT+CFUN=0)	Instrument environment	44.0	mA
		Open Sky @Passive Antenna	53.0	mA
		Open Sky @Active Antenna	58.0	mA

6.7. Thermal Consideration

In order to achieve better performance of the module, it is recommended to comply with the following principles for thermal consideration:

- On customers' PCB design, please keep placement of the PCI Express Mini Card away from heating sources.
- Do not place components on the PCB area where the module is mounted, in order to facilitate adding of heatsink.
- Do not apply solder mask on the PCB area where the module is mounted, so as to ensure better heat dissipation performance.
- The reference ground of the area where the module is mounted should be complete, and add ground

vias as many as possible for better heat dissipation.

- Add a heatsink on the top of the module and the heatsink should be designed with as many fins as possible to increase heat dissipation area. Meanwhile, a thermal pad with high thermal conductivity should be used between the heatsink and module.
- Add a thermal pad with appropriate thickness at the bottom of the module to conduct the heat to PCB.

The following figure shows the referenced heatsink design.

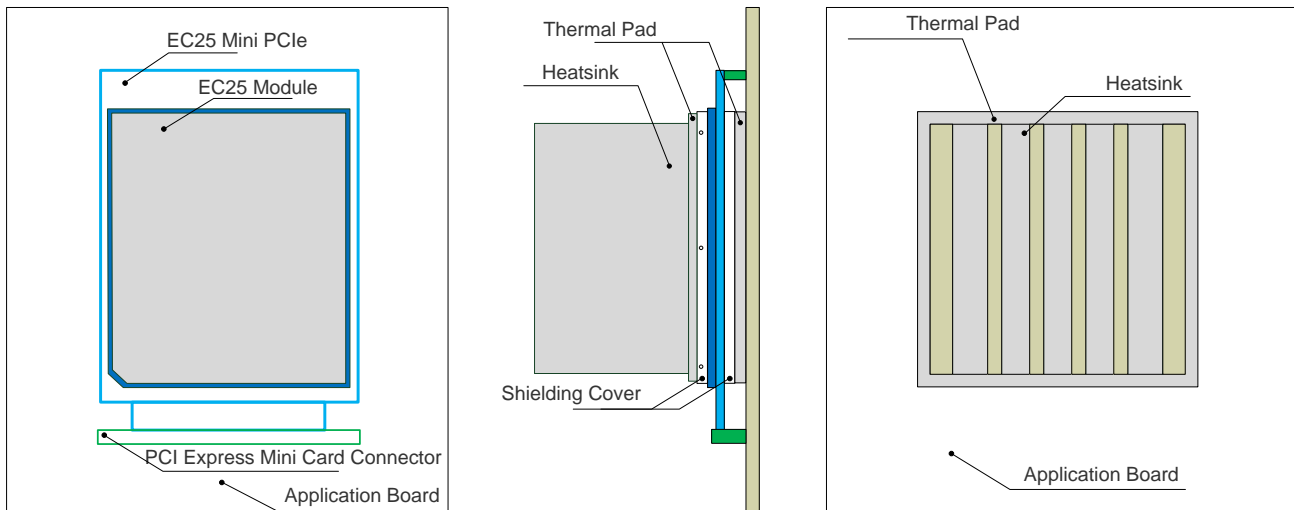

Figure 17: Referenced Heatsink Design

NOTES

1. The module offers the best performance when the internal BB chip stays below 105°C. When the maximum temperature of the BB chip reaches or exceeds 105°C, the module works normal but provides reduced performance (such as RF output power, data rate, etc.). When the maximum BB chip temperature reaches or exceeds 115°C, the module will disconnect from the network, and it will recover to network connected state after the maximum temperature falls below 115°C. Therefore, the thermal design should be maximally optimized to make sure the maximum BB chip temperature always maintains below 105°C. Customers can execute **AT+QTEMP** command and get the maximum BB chip temperature from the first returned value.
2. For more detailed guidelines on thermal design, please refer to **document [4]**.

7 Dimensions and Packaging

7.1. General Description

This chapter mainly describes mechanical dimensions as well as packaging specification of EC25 Mini PCIe module. All dimensions are measured in millimeter (mm), and the dimensional tolerances are $\pm 0.05\text{mm}$ unless otherwise specified.

7.2. Mechanical Dimensions of EC25 Mini PCIe

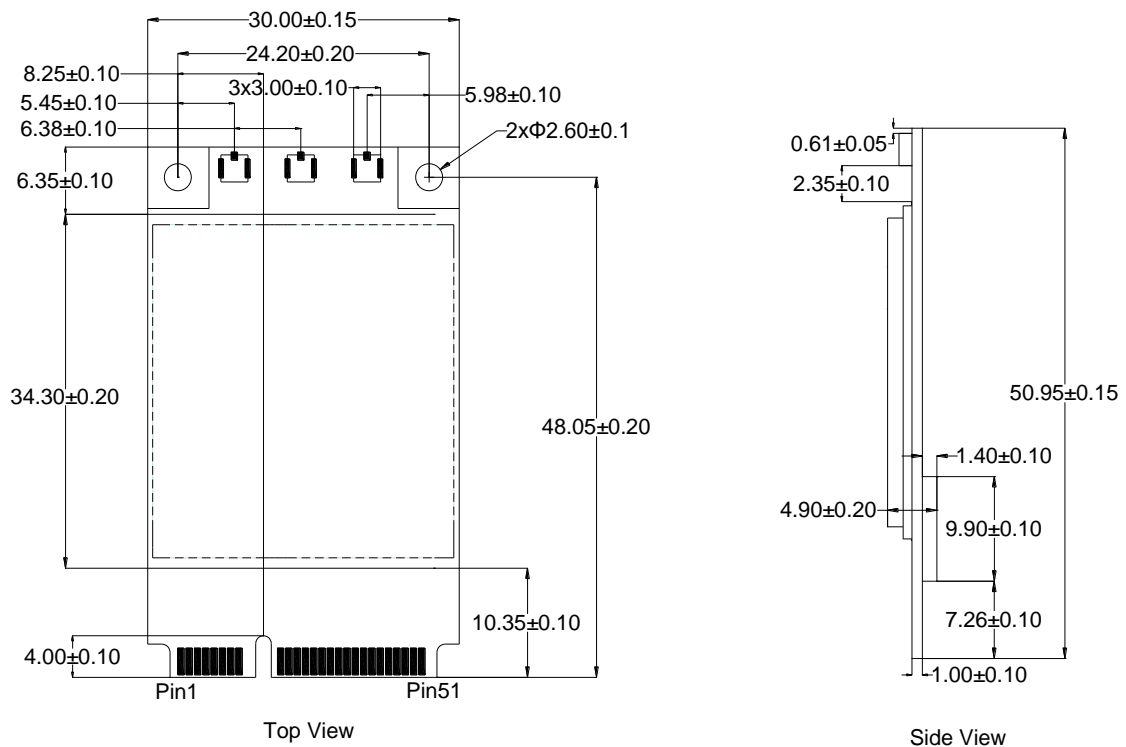

Figure 18: Mechanical Dimensions of EC25 Mini PCIe

7.3. Standard Dimensions of Mini PCI Express

The following figure shows the standard dimensions of Mini PCI Express. Please refer to **document [1]** for Detail A and Detail B.

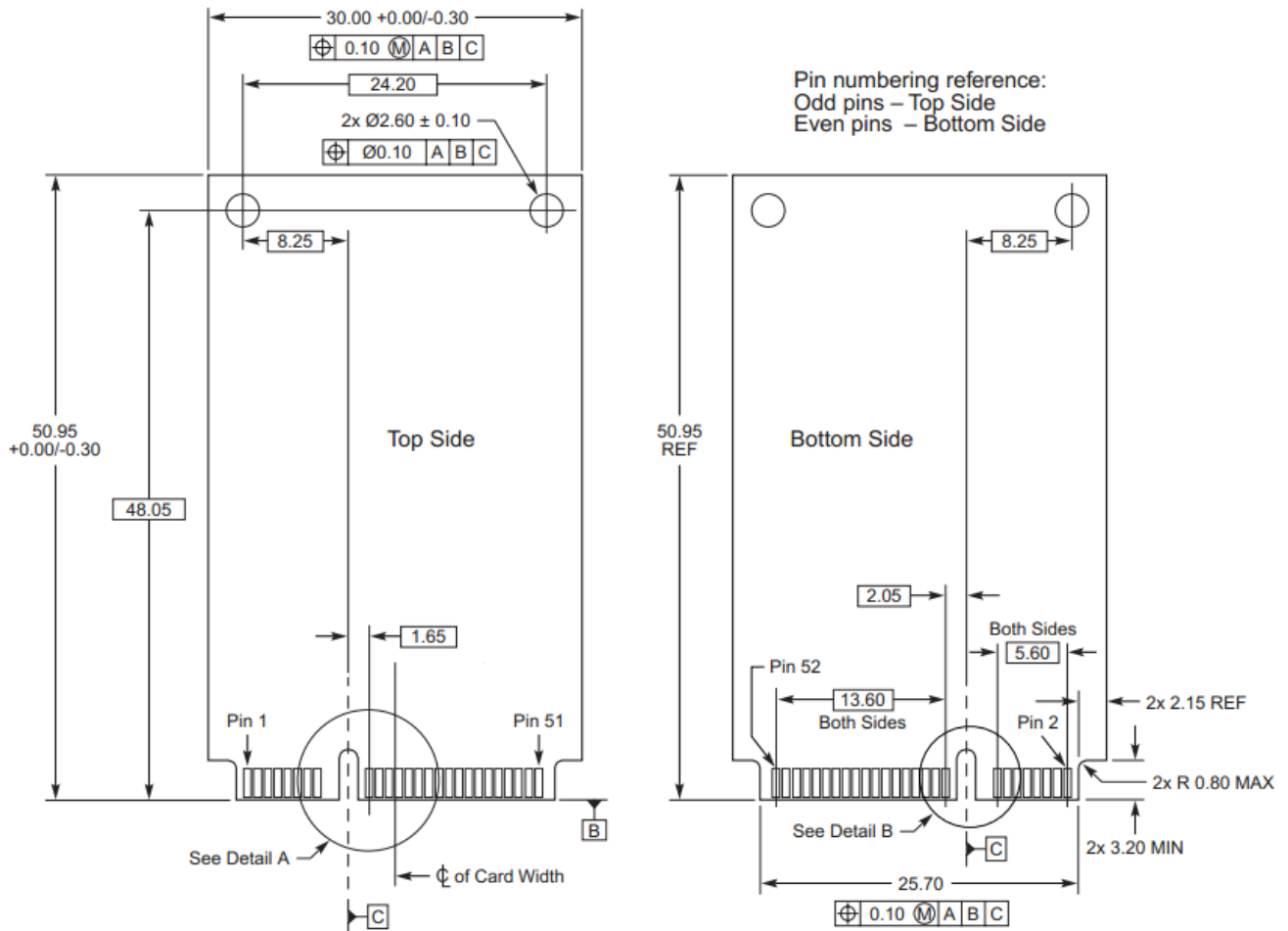

Figure 19: Standard Dimensions of Mini PCI Express

EC25 Mini PCIe adopts a standard Mini PCI Express connector which complies with the directives and standards listed in the **document [1]**. The following figure takes the Molex 679105700 as an example.

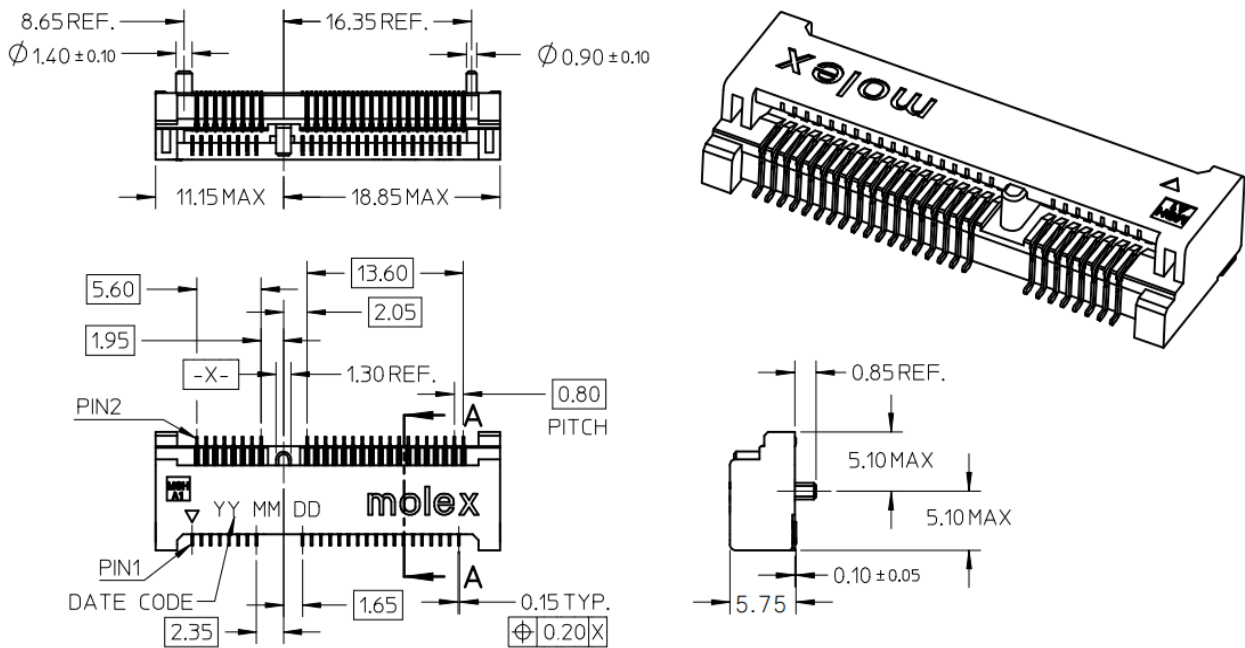

Figure 20: Dimensions of the Mini PCI Express Connector (Molex 679105700)

7.4. Packaging Specifications

EC25 Mini PCIe modules are packaged in a tray. Each tray contains 10 modules. The smallest package of EC25 Mini PCIe contains 100 modules.

8 Appendix A References

Table 52: Related Documents

SN	Document Name	Remark
[1]	PCI Express Mini Card Electromechanical Specification Revision 1.2	PCI Express Mini Card Electromechanical Specification
[2]	Quectel_LTE_Standard_AT_Commands_Manual	AT commands manual for LTE Standard modules
[3]	Quectel_LTE_Standard_GNSS_Application_Note	GNSS application note for LTE Standard modules
[4]	Quectel_LTE_Module_Thermal_Design_Guide	Thermal design guide for LTE standard, LTE-A and Automotive modules

Table 53: Terms and Abbreviations

Abbreviation	Description
AMR	Adaptive Multi-rate
bps	Bits Per Second
BT	Bluetooth
CS	Coding Scheme
CTS	Clear to Send
DC-HSPA+	Dual-carrier High Speed Packet Access
DFOTA	Delta Firmware Upgrade Over-The-Air
DL	Down Link
DTE	Data Terminal Equipment
DTR	Data Terminal Ready
EFR	Enhanced Full Rate

EMI	Electro Magnetic Interference
ESD	Electrostatic Discharge
ESR	Equivalent Series Resistance
FDD	Frequency Division Duplexing
FR	Full Rate
GLONASS	GLObalnaya Navigatsionnaya Sputnikovaya Sistema, the Russian Global Navigation Satellite System
GMSK	Gaussian Minimum Shift Keying
GNSS	Global Navigation Satellite System
GPS	Global Positioning System
GSM	Global System for Mobile Communications
HR	Half Rate
HSPA	High Speed Packet Access
HSUPA	High Speed Uplink Packet Access
kbps	Kilo Bits Per Second
LED	Light Emitting Diode
LTE	Long-Term Evolution
Mbps	Million Bits Per Second
MCU	Micro Control Unit
ME	Mobile Equipment
MIMO	Multiple-Input Multiple-Output
MMS	Multimedia Messaging Service
MO	Mobile Originated
MT	Mobile Terminated
NMEA	National Marine Electronics Association
PCM	Pulse Code Modulation

PDA	Personal Digital Assistant
PDU	Protocol Data Unit
POS	Point of Sale
PPP	Point-to-Point Protocol
RF	Radio Frequency
RTS	Ready To Send
Rx	Receive
SIMO	Single Input Multiple Output
SMS	Short Message Service
TX	Transmitting Direction
TVS	Transient Voltage Suppressor
UART	Universal Asynchronous Receiver & Transmitter
UL	Uplink
URC	Unsolicited Result Code
USB	Universal Serial Bus
(U)SIM	(Universal) Subscriber Identification Module
WCDMA	Wideband Code Division Multiple Access
WLAN	Wireless Local Area Networks
