

BG95 Series

Hardware Design

LPWA Module Series

Rev. BG95_Series_Hardware_Design_V1.2

Date: 2020-07-06

Status: Released



Our aim is to provide customers with timely and comprehensive service. For any assistance, please contact our company headquarters:

Quectel Wireless Solutions Co., Ltd.

Building 5, Shanghai Business Park Phase III (Area B), No.1016 Tianlin Road, Minhang District, Shanghai 200233, China

Tel: +86 21 5108 6236

Email: info@quectel.com

Or our local office. For more information, please visit:

<http://www.quectel.com/support/sales.htm>

For technical support, or to report documentation errors, please visit:

<http://www.quectel.com/support/technical.htm>

Or email to: support@quectel.com

GENERAL NOTES

QUECTEL OFFERS THE INFORMATION AS A SERVICE TO ITS CUSTOMERS. THE INFORMATION PROVIDED IS BASED UPON CUSTOMERS' REQUIREMENTS. QUECTEL MAKES EVERY EFFORT TO ENSURE THE QUALITY OF THE INFORMATION IT MAKES AVAILABLE. QUECTEL DOES NOT MAKE ANY WARRANTY AS TO THE INFORMATION CONTAINED HEREIN, AND DOES NOT ACCEPT ANY LIABILITY FOR ANY INJURY, LOSS OR DAMAGE OF ANY KIND INCURRED BY USE OF OR RELIANCE UPON THE INFORMATION. ALL INFORMATION SUPPLIED HEREIN IS SUBJECT TO CHANGE WITHOUT PRIOR NOTICE.

COPYRIGHT

THE INFORMATION CONTAINED HERE IS PROPRIETARY TECHNICAL INFORMATION OF QUECTEL WIRELESS SOLUTIONS CO., LTD. TRANSMITTING, REPRODUCTION, DISSEMINATION AND EDITING OF THIS DOCUMENT AS WELL AS UTILIZATION OF THE CONTENT WITHOUT PERMISSION ARE FORBIDDEN. OFFENDERS WILL BE HELD LIABLE FOR PAYMENT OF DAMAGES. ALL RIGHTS ARE RESERVED IN THE EVENT OF A PATENT GRANT OR REGISTRATION OF A UTILITY MODEL OR DESIGN.

Copyright © Quectel Wireless Solutions Co., Ltd. 2020. All rights reserved.

About the Document

Revision History

Version	Date	Author	Description
1.0	2019-09-30	Lyndon LIU/ Garey XIE	Initial
1.1	2020-02-28	Lyndon LIU/ Garey XIE	<ol style="list-style-type: none"> 1. Updated the GNSS function into an optional feature. 2. Updated the LTE Power Class 5 to 21 dBm. 3. Added the parameters (power supply, operating frequency, output power, etc.) of BG95-M4 and BG95-M5. 4. Updated the transmitting power parameters in Table 3 and Table 40. 5. Updated the pin name of pin 21 from NETLIGHT into NET_STATUS. 6. Updated the block diagram in Figure 1. 7. Updated the power-on timing in Figure 8. 8. Updated the reference design of USB interface in Figure 16. 9. Updated the name of UART interface pins. 10. Added a recommended GNSS UART reference design (Dual-Transistor Solution) in Figure 19. 11. Added the timing of turning on the module with USB_BOOT in Figure 24. 12. Added the truth table of GRFC interfaces in Table 29. 13. Updated the GNSS performance in Table 30. 14. Updated the current consumption parameters in Chapter 6.4. 15. Updated the RF receiving sensitivity in Chapter 6.6.
1.2	2020-07-06	Lyndon LIU/ Ellison WANG	<ol style="list-style-type: none"> 1. Added BG95-M6. 2. Removed B14 for LTE Cat M1 and B26 for LTE Cat NB2. 3. Updated GNSS function into a standard

configuration.

4. Added the power supply range of BG95-M4, and the typical power supply of BG95-MF.
 5. Added the function diagram of BG95-M4, BG95-M5, BG95-M6 and BG95-MF in Chapter 2.3.
 6. Enabled pin 56 (ANT_WIFI) for BG95-MF.
 7. Updated the GNSS performance in Table 30.
 8. Added the current consumption values of BG95-M1, BG95-M2, BG95-M5 and BG95-M6 in Chapter 6.4.
 9. Updated the GNSS current consumption values in Chapter 6.4.
 10. Added the RF output power values of BG95-M4, BG95-M5 and BG95-M6 in Chapter 6.5.
 11. Updated the RF receiving sensitivity of BG95-M3 and added that of BG95-M5 in Chapter 6.6
 12. Updated electrostatic discharge characteristics in Chapter 6.7.
 13. Updated the description of storage conditions in Chapter 8.1.
 14. Updated the recommended reflow soldering thermal profile parameters in Chapter 8.2.
-

Contents

About the Document	2
Contents.....	4
Table Index	7
Figure Index.....	9
1 Introduction	11
1.1. Safety Information	11
2 Product Concept	13
2.1. General Description.....	13
2.2. Key Features	16
2.3. Functional Diagram	18
2.4. Evaluation Board	22
3 Application Interfaces.....	23
3.1. Pin Assignment	23
3.2. Pin Description	25
3.3. Operating Modes.....	33
3.4. Power Saving	34
3.4.1. Airplane Mode.....	34
3.4.2. Power Saving Mode (PSM).....	35
3.4.3. Extended Idle Mode DRX (e-I-DRX).....	36
3.4.4. Sleep Mode.....	36
3.4.4.1. UART Application	36
3.5. Power Supply	37
3.5.1. Power Supply Pins.....	37
3.5.2. Decrease Voltage Drop	38
3.5.3. Monitor the Power Supply.....	40
3.6. Turn on and off Scenarios	40
3.6.1. Turn on Module Using the PWRKEY Pin.....	40
3.6.2. Turn off Module.....	42
3.6.2.1. Turn off Module through PWRKEY	42
3.6.2.2. Turn off Module through AT Command	42
3.7. Reset the Module	43
3.8. PON_TRIG Interface	44
3.9. (U)SIM Interface	45
3.10. USB Interface	47
3.11. UART Interfaces.....	49
3.12. PCM and I2C Interfaces*	52
3.13. Network Status Indication.....	53
3.14. STATUS	54

3.15.	Behaviors of MAIN_RI	55
3.16.	USB_BOOT Interface	56
3.17.	ADC Interfaces	57
3.18.	GPIO Interfaces.....	58
3.19.	GRFC Interfaces	60
4	GNSS Receiver	61
4.1.	General Description.....	61
4.2.	GNSS Performance.....	61
4.3.	Layout Guidelines.....	62
5	Antenna Interfaces.....	63
5.1.	Main Antenna Interface	63
5.1.1.	Pin Definition.....	63
5.1.2.	Operating Frequency	63
5.1.3.	Reference Design of Main Antenna Interface	64
5.1.4.	Reference Design of RF Layout.....	65
5.2.	GNSS Antenna Interface	67
5.3.	Wi-Fi Antenna Interface*	68
5.4.	Antenna Installation	69
5.4.1.	Antenna Requirements	69
5.4.2.	Recommended RF Connector for Antenna Installation.....	69
6	Electrical, Reliability and Radio Characteristics	72
6.1.	Absolute Maximum Ratings.....	72
6.2.	Power Supply Ratings	72
6.3.	Operating and Storage Temperatures	73
6.4.	Current Consumption	73
6.5.	RF Output Power.....	84
6.6.	RF Receiving Sensitivity.....	86
6.7.	Electrostatic Discharge.....	90
7	Mechanical Dimensions.....	91
7.1.	Top and Side Dimensions	91
7.2.	Recommended Footprint	93
7.3.	Top and Bottom Views	94
8	Storage, Manufacturing and Packaging.....	95
8.1.	Storage.....	95
8.2.	Manufacturing and Soldering.....	96
8.3.	Packaging.....	97
9	Appendix A References	100
10	Appendix B GPRS Coding Schemes	103
11	Appendix C GPRS Multi-slot Classes.....	104
12	Appendix D EDGE Modulation and Coding Schemes.....	106

13 Appendix E Compulsory Certifications.....	107
13.1. IC Statement	110

Table Index

Table 1: Version Selection for BG95 Series Modules.....	13
Table 2: Frequency Bands and GNSS Types of BG95 Series Modules.....	13
Table 3: Key Features of BG95 Series Modules	16
Table 4: Definition of I/O Parameters	25
Table 5: Pin Description	26
Table 6: Overview of BG95 Operating Modes	34
Table 7: VBAT and GND Pins	38
Table 8: Pin Definition of PWRKEY	40
Table 9: Pin Definition of RESET_N.....	43
Table 10: Pin Definition of PON_TRIG Interface	44
Table 11: Pin Definition of (U)SIM Interface	45
Table 12: Pin Definition of USB Interface	47
Table 13: Pin Definition of Main UART Interface.....	49
Table 14: Pin Definition of Debug UART Interface	50
Table 15: Pin Definition of GNSS UART Interface.....	50
Table 16: Logic Levels of Digital I/O.....	50
Table 17: Pin Definition of PCM and I2C Interfaces	53
Table 18: Pin Definition of NET_STATUS	54
Table 19: Working State of NET_STATUS.....	54
Table 20: Pin Definition of STATUS	55
Table 21: Default Behaviors of MAIN_RI Pin	55
Table 22: Pin Definition of USB_BOOT Interface.....	56
Table 23: Pin Definition of ADC Interface	58
Table 24: Characteristics of ADC Interfaces	58
Table 25: Pin Definition of GPIO Interfaces.....	59
Table 26: Logic Levels of GPIO Interfaces.....	59
Table 27: Pin Definition of GRFC Interfaces	60
Table 28: Logic Levels of GRFC Interfaces.....	60
Table 29: Truth Table of GRFC Interfaces	60
Table 30: GNSS Performance.....	61
Table 31: Pin Definition of Main Antenna Interface	63
Table 32: Operating Frequency of BG95 Series Module.....	63
Table 33: Pin Definition of GNSS Antenna Interface	67
Table 34: GNSS Frequency	67
Table 35: Pin Definition of Wi-Fi Antenna Interface.....	68
Table 36: Antenna Requirements.....	69
Table 37: Absolute Maximum Ratings.....	72
Table 38: Power Supply Ratings	72
Table 39: Operating and Storage Temperatures.....	73
Table 40: BG95-M1 Current Consumption (3.3 V Power Supply, Room Temperature)	74
Table 41: BG95-M2 Current Consumption (3.3 V Power Supply, Room Temperature)	75

Table 42: BG95-M3 Current Consumption (3.8 V Power Supply, Room Temperature)	77
Table 43: BG95-M5 Current Consumption (3.8 V Power Supply, Room Temperature)	79
Table 44: BG95-M6 Current Consumption (3.8 V Power Supply, Room Temperature)	81
Table 45: GNSS Current Consumption of BG95-M1/-M2 (3.3 V Power Supply, Room Temperature)	83
Table 46: GNSS Current Consumption of BG95-M3 (3.8 V Power Supply, Room Temperature)	84
Table 47: GNSS Current Consumption of BG95-M5/-M6 (3.8 V Power Supply, Room Temperature)	84
Table 48: Conducted RF Output Power of BG95-M1/-M2/-M3/-N1/-MF	85
Table 49: Conducted RF Output Power of BG95-M4	85
Table 50: Conducted RF Output Power of BG95-M5/-M6	85
Table 51: Conducted RF Receiving Sensitivity of BG95-M1	86
Table 52: Conducted RF Receiving Sensitivity of BG95-M2	87
Table 53: Conducted RF Receiving Sensitivity of BG95-M3	88
Table 54: Conducted RF Receiving Sensitivity of BG95-M5	89
Table 55: Electrostatic Discharge Characteristics (25 °C, 45 % Relative Humidity)	90
Table 56: Recommended Thermal Profile Parameters	97
Table 57: Packaging Specifications of BG95	99
Table 58: Related Documents	100
Table 59: Terms and Abbreviations	100
Table 60: Description of Different Coding Schemes	103
Table 61: GPRS Multi-slot Classes	104
Table 62: EDGE Modulation and Coding Schemes	106

Figure Index

Figure 1: Functional Diagram of BG95-M3	19
Figure 2: Pin Assignment (Top View)	24
Figure 3: Sleep Mode Application via UART	37
Figure 4: Power Supply Limits during Burst Transmission (BG95-M3/-M5)	39
Figure 5: Star Structure of the Power Supply	39
Figure 6: Turn on the Module Using Driving Circuit.....	40
Figure 7: Turn on the Module Using Keystroke	41
Figure 8: Power-on Timing	41
Figure 9: Power-off Timing	42
Figure 10: Reset Timing	43
Figure 11: Reference Circuit of RESET_N by Using Driving Circuit.....	43
Figure 12: Reference Circuit of RESET_N by Using Button.....	44
Figure 13: Reference Circuit of PON_TRIG	45
Figure 14: Reference Circuit of (U)SIM Interface with an 8-Pin (U)SIM Card Connector	46
Figure 15: Reference Circuit of (U)SIM Interface with a 6-Pin (U)SIM Card Connector	46
Figure 16: Reference Design of USB Interface	48
Figure 17: Main UART Reference Design (Translator Chip)	51
Figure 18: Main UART Reference Design (Transistor Circuit).....	51
Figure 19: Reference Circuit with Dual-Transistor Circuit (Recommended for GNSS UART).....	52
Figure 20: Reference Circuit of PCM Application with Audio Codec	53
Figure 21: Reference Circuit of the Network Status Indicator.....	54
Figure 22: Reference Design of STATUS	55
Figure 23: Reference Design of USB_BOOT Interface	56
Figure 24: Timing of Turning on Module with USB_BOOT	57
Figure 25: Reference Design of Main Antenna Interface.....	65
Figure 26: Microstrip Design on a 2-layer PCB	65
Figure 27: Coplanar Waveguide Design on a 2-layer PCB	66
Figure 28: Coplanar Waveguide Design on a 4-layer PCB (Layer 3 as Reference Ground).....	66
Figure 29: Coplanar Waveguide Design on a 4-layer PCB (Layer 4 as Reference Ground).....	66
Figure 30: Reference Circuit of GNSS Antenna Interface	68
Figure 31: Dimensions of the U.FL-R-SMT Connector (Unit: mm)	70
Figure 32: Mechanicals of U.FL-LP Connectors.....	70
Figure 33: Space Factor of Mated Connector (Unit: mm).....	71
Figure 34: Module Top and Side Dimensions	91
Figure 35: Module Bottom Dimensions (Bottom View).....	92
Figure 36: Recommended Footprint (Top View).....	93
Figure 37: Top View of the Module.....	94
Figure 38: Bottom View of the Module	94
Figure 39: Recommended Reflow Soldering Thermal Profile.....	96
Figure 40: Tape Dimensions	98
Figure 41: Reel Dimensions	98

Figure 42: JATE/TELEC Certification ID of BG95-M5 107

1 Introduction

This document defines BG95 series module and describes its air interface and hardware interfaces which are connected with your applications.

This document helps you quickly understand the interface specifications, electrical and mechanical details, as well as other related information of BG95 series module. To facilitate application designs, it also includes some reference designs for your reference. The document, coupled with application notes and user guides, makes it easy to design and set up mobile applications with BG95 series module.

This document defines the BG95-MF module and describes its air interface and hardware interface which are connected with the customers' applications.

The document helps customers quickly understand module interface specifications, electrical and mechanical details, as well as other related information of the module. Associated with relevant application notes and user guides, customers can use BG95-MF to design and set up mobile applications easily.

CE Statement

The minimum distance between the user and/or any bystander and the radiating structure of the transmitter is 20cm.

Hereby, We, Quectel Wireless Solutions Co., Ltd. declares that the radio equipment type BG95-MF is in compliance with the Directive 2014/53/EU.

The full text of the EU declaration of conformity is available at the following internet address:
Building 5, Shanghai Business Park Phase III (Area B), No.1016 Tianlin Road, Minhang District,
Shanghai
200233, China

<https://www.quectel.com/support/downloadb/TechnicalDocuments.htm>

The device operates with the following frequency bands and transmitting power:

1.1. Safety Information

The following safety precautions must be observed during all phases of operation, such as usage, service or repair of any cellular terminal or mobile incorporating BG95 series module. Manufacturers of the cellular terminal should notify users and operating personnel of the following safety information by incorporating these guidelines into all manuals supplied with the product. If not so, Quectel assumes no liability for any user's failure to observe these precautions.



Full attention must be paid to driving at all times in order to reduce the risk of an accident. Using a mobile while driving (even with a handsfree kit) causes distraction and can lead to an accident. Please comply with laws and regulations restricting the use of wireless devices while driving.



Switch off the cellular terminal or mobile before boarding an aircraft. The operation of wireless appliances in an aircraft is forbidden to prevent interference with communication systems. If there is an Airplane Mode, it should be enabled prior to boarding an aircraft. Please consult the airline staff for more restrictions on the use of wireless devices on an aircraft.



Wireless devices may cause interference on sensitive medical equipment, so please be aware of the restrictions on the use of wireless devices when in hospitals, clinics or other healthcare facilities.



Cellular terminals or mobiles operating over radio signals and cellular network cannot be guaranteed to connect in all possible conditions (for example, with unpaid bills or with an invalid (U)SIM card). When emergent help is needed in such conditions, use emergency call. In order to make or receive a call, the cellular terminal or mobile must be switched on in a service area with adequate cellular signal strength.



The cellular terminal or mobile contains a transmitter and receiver. When it is ON, it receives and transmits radio frequency signals. RF interference can occur if it is used close to TV set, radio, computer or other electric equipment.



In locations with potentially explosive atmospheres, obey all posted signs to turn off wireless devices such as mobile phone or other cellular terminals. Areas with potentially explosive atmospheres include fuelling areas, below decks on boats, fuel or chemical transfer or storage facilities, areas where the air contains chemicals or particles such as grain, dust or metal powders, etc.

2 Product Concept

2.1. General Description

BG95 is a series of embedded IoT (LTE Cat M1, LTE Cat NB2 and EGPRS) wireless communication modules. It provides data connectivity on LTE-FDD and GPRS/EGPRS networks, and supports half-duplex operation in LTE network. It also provides GNSS and voice* ¹⁾ functionality to meet your specific application demands.

Table 1: Version Selection for BG95 Series Modules

Model	Cat M1	Cat NB2 ²⁾	GSM	Wi-Fi Positioning	GNSS
BG95-M1	●	-	-	-	●
BG95-M2	●	●	-	-	●
BG95-M3	●	●	●	-	●
BG95-N1	-	●	-	-	●
BG95-M4	●	●	-	-	●
BG95-M5	●	●	●	-	●
BG95-M6	●	●	-	-	●
BG95-MF	●	●	-	●	●

Table 2: Frequency Bands and GNSS Types of BG95 Series Modules

Module	Supported Bands	LTE Bands Power Class	GNSS
BG95-M1	Cat M1 Only: LTE-FDD: B1/B2/B3/B4/B5/B8/B12/B13/ B18/B19/B20/B25/B26/B27/B28/	Power Class 5 (21 dBm)	GPS, GLONASS, BeiDou, Galileo, QZSS

	B66/B85		
BG95-M2	<p>Cat M1: LTE-FDD: B1/B2/B3/B4/B5/B8/B12/B13/ B18/B19/B20/B25/B26/B27/B28/ B66/B85</p> <p>Cat NB2: LTE-FDD: B1/B2/B3/B4/B5/B8/B12/B13/ B18/B19/B20/B25/B28/B66/B71/ B85</p>	Power Class 5 (21 dBm)	GPS, GLONASS, BeiDou, Galileo, QZSS
BG95-M3	<p>Cat M1: LTE-FDD: B1/B2/B3/B4/B5/B8/B12/B13/ B18/B19/B20/B25/B26/B27/ B28/B66/B85</p> <p>Cat NB2: LTE-FDD: B1/B2/B3/B4/B5/B8/B12/B13/ B18/B19/B20/B25/B28/B66/B71/ B85</p> <p>EGPRS: 850/900/1800/1900 MHz</p>	Power Class 5 (21 dBm)	GPS, GLONASS, BeiDou, Galileo, QZSS
BG95-N1	<p>Cat NB2 Only: LTE FDD: B1/B2/B3/B4/B5/B8/B12/B13/ B18/B19/B20/B25/B28/B66/B71/ B85</p>	Power Class 5 (21 dBm)	GPS, GLONASS, BeiDou, Galileo, QZSS
BG95-M4	<p>Cat M1: LTE-FDD: B1/B2/B3/B4/B5/B8/B12/B13/ B18/B19/B20/B25/B26/B27/B28/ B31/B66/B72/B73/B85</p> <p>Cat NB2: LTE-FDD: B1/B2/B3/B4/B5/B8/B12/B13/ B18/B19/B20/B25/B28/B31/B66/ B72/B73/B85</p>	<p>Power Class 2* (26 dBm) @ B31/B72/B73</p> <p>Power Class 3 (23 dBm) @ B31/B72/B73</p> <p>Power Class 5 (21 dBm) @ other LTE bands</p>	GPS, GLONASS, BeiDou, Galileo, QZSS
BG95-M5	<p>Cat M1: LTE-FDD: B1/B2/B3/B4/B5/B8/B12/B13/ B18/B19/B20/B25/B26/B27/B28/ B66/B85</p>	Power Class 3 (23 dBm)	GPS, GLONASS, BeiDou, Galileo, QZSS

	<p>Cat NB2: LTE-FDD: B1/B2/B3/B4/B5/B8/B12/B13/ B18/B19/B20/B25/B28/B66/B71/ B85</p> <p>EGPRS: 850/900/1800/1900 MHz</p>		
BG95-M6	<p>Cat M1: LTE-FDD: B1/B2/B3/B4/B5/B8/B12/B13/ B18/B19/B20/B25/B26/B27/B28/ B66/B85</p> <p>Cat NB2: LTE-FDD: B1/B2/B3/B4/B5/B8/B12/B13/ B18/B19/B20/B25/B28/B66/B71/ B85</p>	Power Class 3 (23 dBm)	GPS, GLONASS, BeiDou, Galileo, QZSS
BG95-MF	<p>Cat M1: LTE-FDD: B1/B2/B3/B4/B5/B8/B12/B13/ B18/B19/B20/B25/B26/B27/ B28/B66/B85</p> <p>Cat NB2: LTE-FDD: B1/B2/B3/B4/B5/B8/B12/B13/ B18/B19/B20/B25/B28/B66/B71/ B85</p> <p>Wi-Fi (For Positioning Only): 2.4 GHz</p>	Power Class 5 (21 dBm)	GPS, GLONASS, BeiDou, Galileo, QZSS

NOTES

- ¹⁾ BG95 series modules support VoLTE (Voice over LTE) under LTE Cat M1. Additionally, BG95-M3 and BG95-M5 support CS voice under GSM.
- ²⁾ LTE Cat NB2 is backward compatible with LTE Cat NB1.
- “●” means supported.
- “*” means under development.

With a compact profile of 23.6 mm × 19.9 mm × 2.2 mm, BG95 can meet almost all requirements for M2M applications such as smart metering, tracking system, security, wireless POS, etc.

BG95 is a series of SMD type modules that can be embedded into applications through the 102 LGA pins. It supports internet service protocols like TCP, UDP and PPP. Based on extended AT commands

developed by Quectel, you can use these internet service protocols easily.

2.2. Key Features

The following table describes the detailed features of BG95 series modules.

Table 3: Key Features of BG95 Series Modules

Features	Details
Power Supply	<p>BG95-M1/-M2/-N1:</p> <ul style="list-style-type: none"> ● Supply voltage ¹⁾: 2.6–4.8 V ● Typical supply voltage: 3.3 V <p>BG95-M3/-M5/-M6:</p> <ul style="list-style-type: none"> ● Supply voltage: 3.3–4.3 V ● Typical supply voltage: 3.8 V <p>BG95-M4:</p> <ul style="list-style-type: none"> ● Supply voltage: 3.2–4.2 V ● Typical supply voltage: 3.8 V <p>BG95-MF:</p> <ul style="list-style-type: none"> ● Typical supply voltage: 3.8 V
Transmitting Power	<p>LTE-FDD bands:</p> <ul style="list-style-type: none"> ● Class 5 (21 dBm +1.7/-3 dB) ● Class 3 (23 dBm ±2 dB) ● Class 2* (26 dBm ±2 dB) <p>GSM bands:</p> <ul style="list-style-type: none"> ● Class 4 (33 dBm ±2 dB) for GSM850 ● Class 4 (33 dBm ±2 dB) for EGSM900 ● Class 1 (30 dBm ±2 dB) for DCS1800 ● Class 1 (30 dBm ±2 dB) for PCS1900 ● Class E2 (27 dBm ±3 dB) for GSM850 8-PSK ● Class E2 (27 dBm ±3 dB) for EGSM900 8-PSK ● Class E2 (26 dBm ±3 dB) for DCS1800 8-PSK ● Class E2 (26 dBm ±3 dB) for PCS1900 8-PSK <p>See Table 2 for the LTE bands power class level of each specific model.</p>
LTE Features	<ul style="list-style-type: none"> ● Support 3GPP Rel. 14 ● Support LTE Cat M1 and LTE Cat NB2 ● Support 1.4 MHz RF bandwidth for LTE Cat M1 ● Support 200 KHz RF bandwidth for LTE Cat NB2 ● Cat M1: Max. 588 kbps (DL)/1119 kbps (UL) ● Cat NB2: Max. 127 kbps (DL)/158.5 kbps (UL)

GSM Features	<p>GPRS:</p> <ul style="list-style-type: none"> ● Support GPRS multi-slot class 33 (33 by default) ● Coding scheme: CS-1, CS-2, CS-3 and CS-4 ● Max. 107 kbps (DL), Max. 85.6 kbps (UL) <p>EDGE:</p> <ul style="list-style-type: none"> ● Support EDGE multi-slot class 33 (33 by default) ● Support GMSK and 8-PSK for different MCS (Modulation and Coding Scheme) ● Downlink coding schemes: MCS 1-9 ● Uplink coding schemes: MCS 1-9 ● Max. 296 kbps (DL), Max. 236.8 kbps (UL)
Internet Protocol Features	<ul style="list-style-type: none"> ● Support PPP/TCP/UDP/SSL/TLS/FTP(S)/HTTP(S)/NITZ/PING/MQTT/CoAP protocols ● Support PAP (Password Authentication Protocol) and CHAP (Challenge Handshake Authentication Protocol) protocols which are usually used for PPP connections
SMS	<ul style="list-style-type: none"> ● Text and PDU mode ● Point to point MO and MT ● SMS cell broadcast ● SMS storage: ME by default
(U)SIM Interface	Support 1.8 V USIM/SIM card only
PCM Interface	Support one digital audio interface: PCM interface for VoLTE or GSM CS voice only
USB Interface	<ul style="list-style-type: none"> ● Compliant with USB 2.0 specification (slave only) ● Support operations at low-speed and full-speed ● Used for AT command communication, data transmission, GNSS NMEA output, software debugging and firmware upgrade ● Support USB serial drivers for Windows 7/8/8.1/10, Linux 2.6–5.4, Android 4.x/5.x/6.x/7.x/8.x/9.x
UART Interfaces	<p>Main UART:</p> <ul style="list-style-type: none"> ● Used for data transmission and AT command communication ● 115200 bps baud rate by default ● The default frame format is 8N1 (8 data bits, no parity, 1 stop bit) ● Support RTS and CTS hardware flow control <p>Debug UART:</p> <ul style="list-style-type: none"> ● Used for software debugging and log output ● Support 115200 bps baud rate <p>GNSS UART:</p> <ul style="list-style-type: none"> ● Used for GNSS data and NMEA sentences output ● 115200 bps baud rate by default
GNSS	<ul style="list-style-type: none"> ● Gen9 VT of Qualcomm (GPS, GLONASS, BeiDou, Galileo and QZSS) ● 1 Hz data update rate by default

AT Commands	3GPP TS 27.007 and 3GPP TS 27.005 AT commands, as well as Quectel enhanced AT commands
Network Indication	One NET_STATUS pin for network connectivity status indication
Antenna Interfaces	Main antenna (ANT_MAIN) and GNSS antenna (ANT_GNSS) interfaces
Physical Characteristics	<ul style="list-style-type: none">● Dimensions: (23.6 ±0.15) mm × (19.9 ±0.15) mm × (2.2 ±0.20) mm● Weight: approx. 2.15 g
Temperature Range	<ul style="list-style-type: none">● Operating temperature range: -35 °C to +75 °C ²⁾● Extended temperature range: -40 °C to +85 °C ³⁾● Storage temperature range: -40 °C to +90 °C
Firmware Upgrade	USB interface, DFOTA*
RoHS	All hardware components are fully compliant with EU RoHS directive

NOTES

- 1) ¹⁾ For every VBAT transition/re-insertion from 0 V, the minimum power supply voltage should be higher than 2.7 V. After the module starts up normally, the minimum safety voltage is 2.6 V. In order to ensure full-function mode, the minimum power supply voltage should be higher than 2.8 V.
- 2) ²⁾ Within operating temperature range, the module meets 3GPP specifications.
- 3) ³⁾ Within extended temperature range, the module remains the ability to establish and maintain functions such as SMS and data transmission, without any unrecoverable malfunction. Radio spectrum and radio network are not influenced, while one or more specifications, such as P_{out}, may exceed the specified tolerances of 3GPP. When the temperature returns to the normal operating temperature levels, the module meets 3GPP specifications again.
4. "*" means under development.

2.3. Functional Diagram

The following figures show the block diagram of BG95 series modules and the major functional parts as listed below.

- Power management
- Baseband
- Radio frequency
- Peripheral interfaces

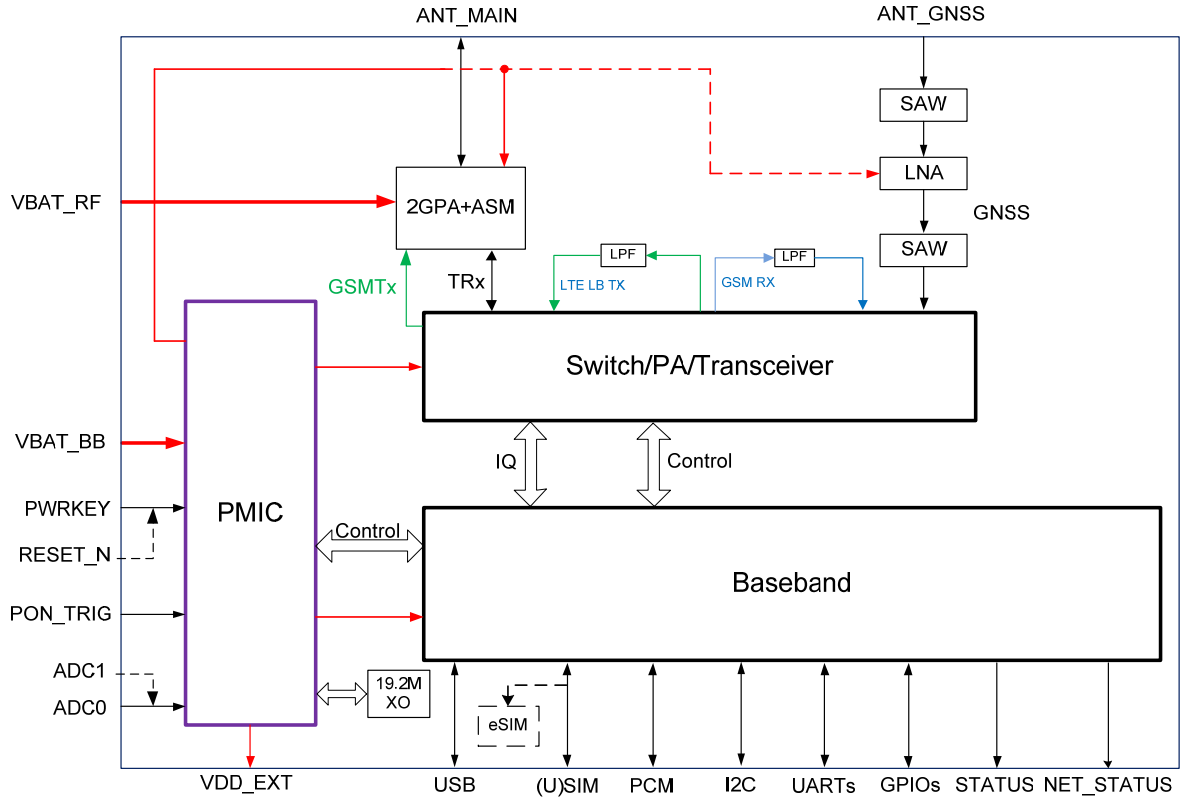

Figure 1: Functional Diagram of BG95-M3

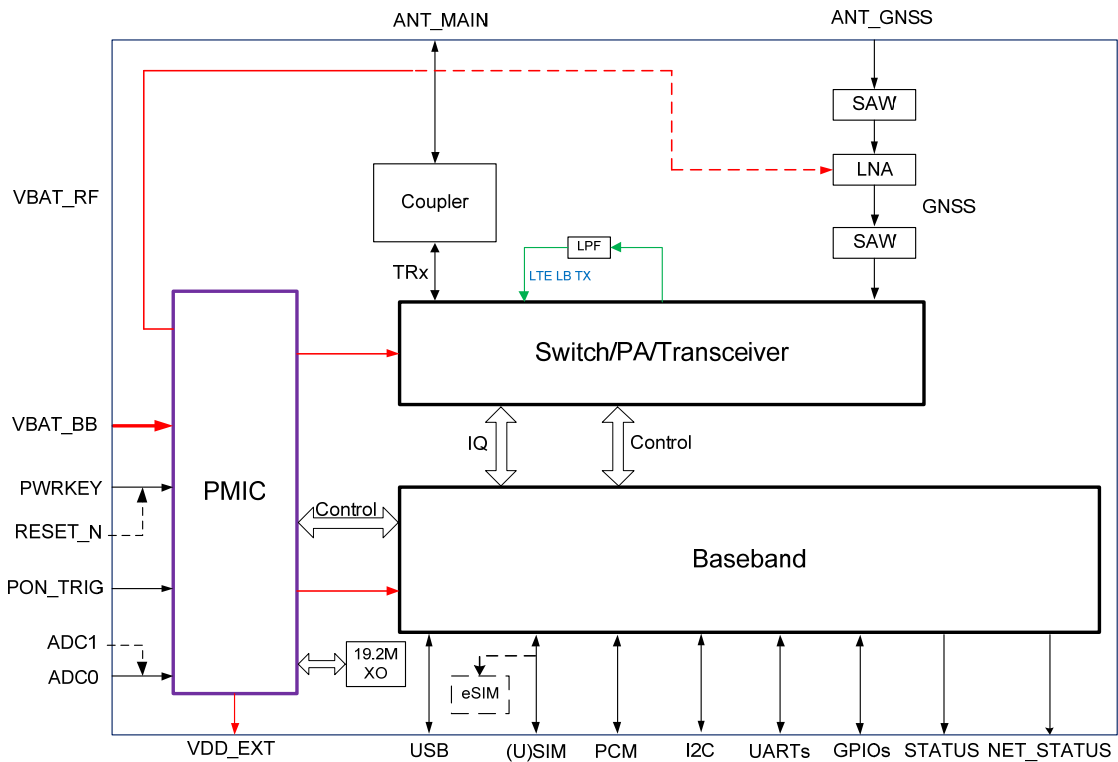

Figure 2: Functional Diagram of BG95-M1/-M2/-N1

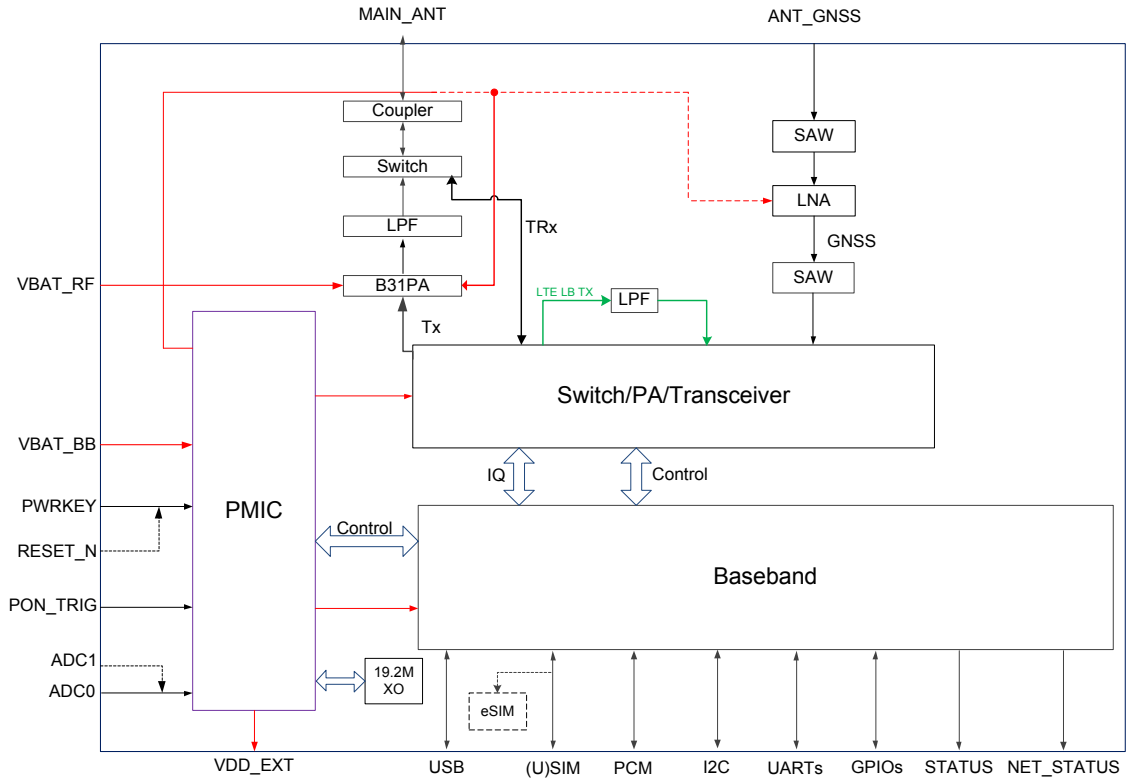

Figure 3: Functional Diagram of BG95-M4

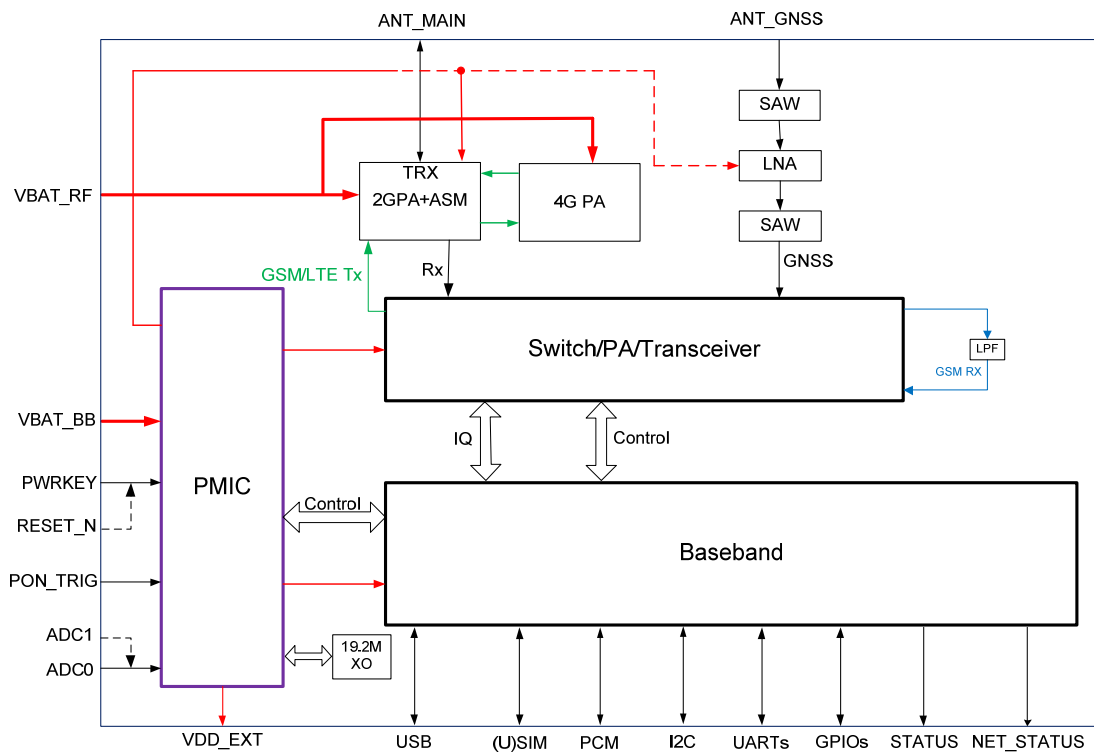

Figure 4: Functional Diagram of BG95-M5

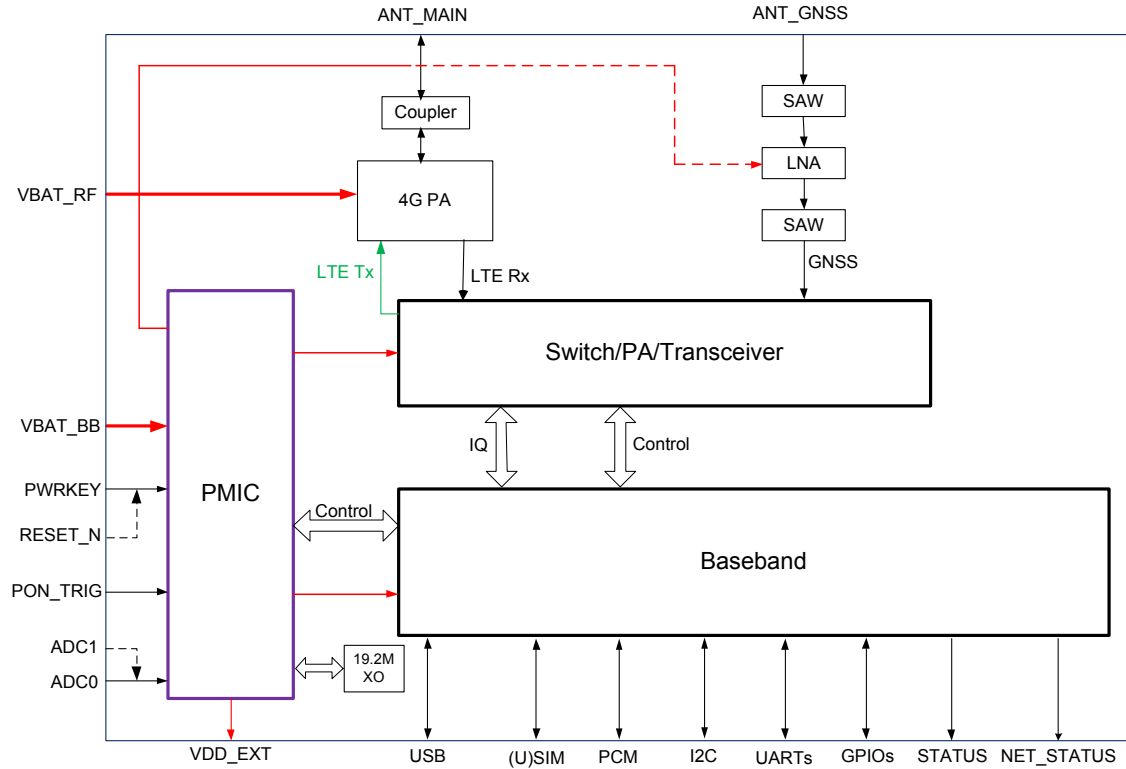

Figure 5: Functional Diagram of BG95-M6

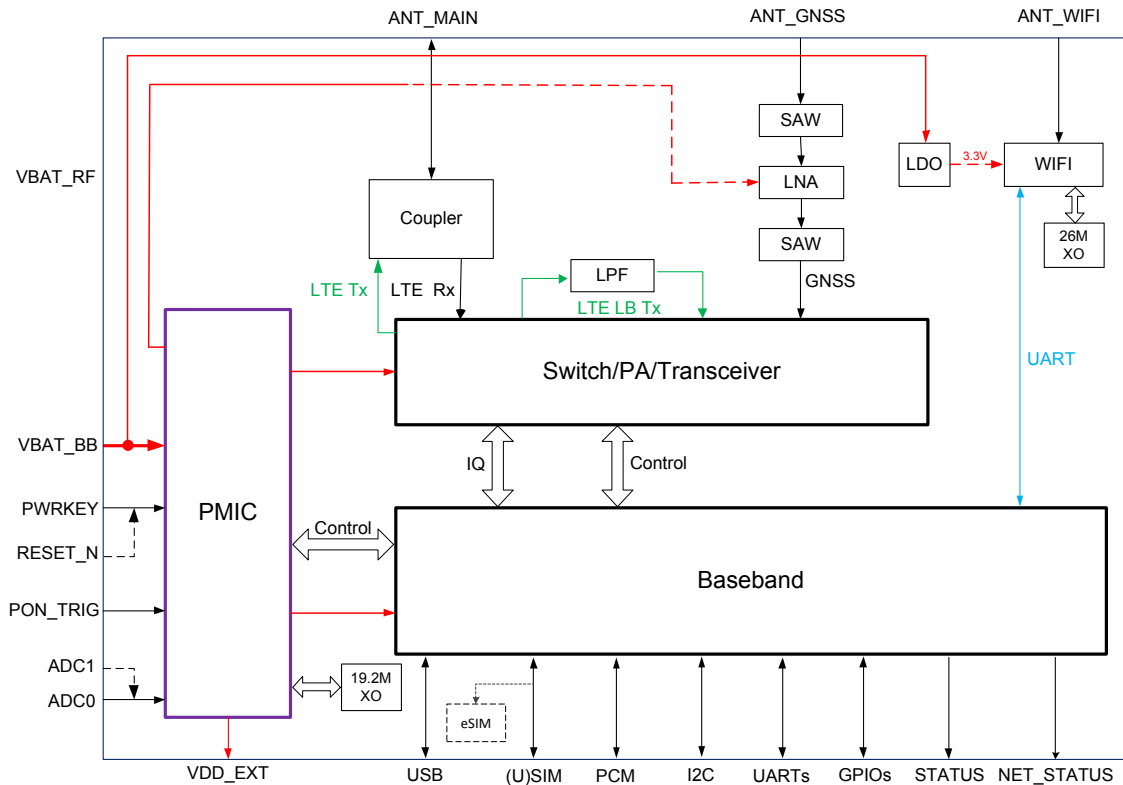

Figure 6: Functional Diagram of BG95-MF

NOTES

1. eSIM function is optional. If eSIM is selected, then any external (U)SIM cannot be used. BG95-M5 and BG95-M6 do not support eSIM.
2. PWRKEY output voltage is 1.5 V because of the voltage drop inside the Qualcomm chipset. Due to platform limitations, the chipset has integrated the reset function into PWRKEY. Therefore, never pull down PWRKEY to GND permanently.
3. RESET_N connects directly to PWRKEY inside the module.
4. Do not use ADC0 and ADC1 simultaneously, as ADC1 connects directly to ADC0 inside the module. BG95 supports use of only one ADC interface at a time: either ADC0 or ADC1.

2.4. Evaluation Board

In order to facilitate application development with BG95 conveniently, Quectel supplies the evaluation board (EVB), USB to RS-232 converter cable, USB data cable, earphone, antenna and other peripherals to control or test the module. For more details, see **document [1]**.

3 Application Interfaces

BG95 series is equipped with 102 LGA pads for connection to various cellular application platforms. The subsequent chapters provide detailed descriptions of the following interfaces:

- Power supply
- PON_TRIG Interface
- (U)SIM interface
- USB interface
- UART interfaces
- PCM and I2C interfaces*
- Status indication interfaces
- USB_BOOT interface
- ADC interfaces
- GPIO interfaces
- GRFC interfaces

NOTE

“*” means under development.

3.1. Pin Assignment

The following figure shows the pin assignment of BG95 series module.

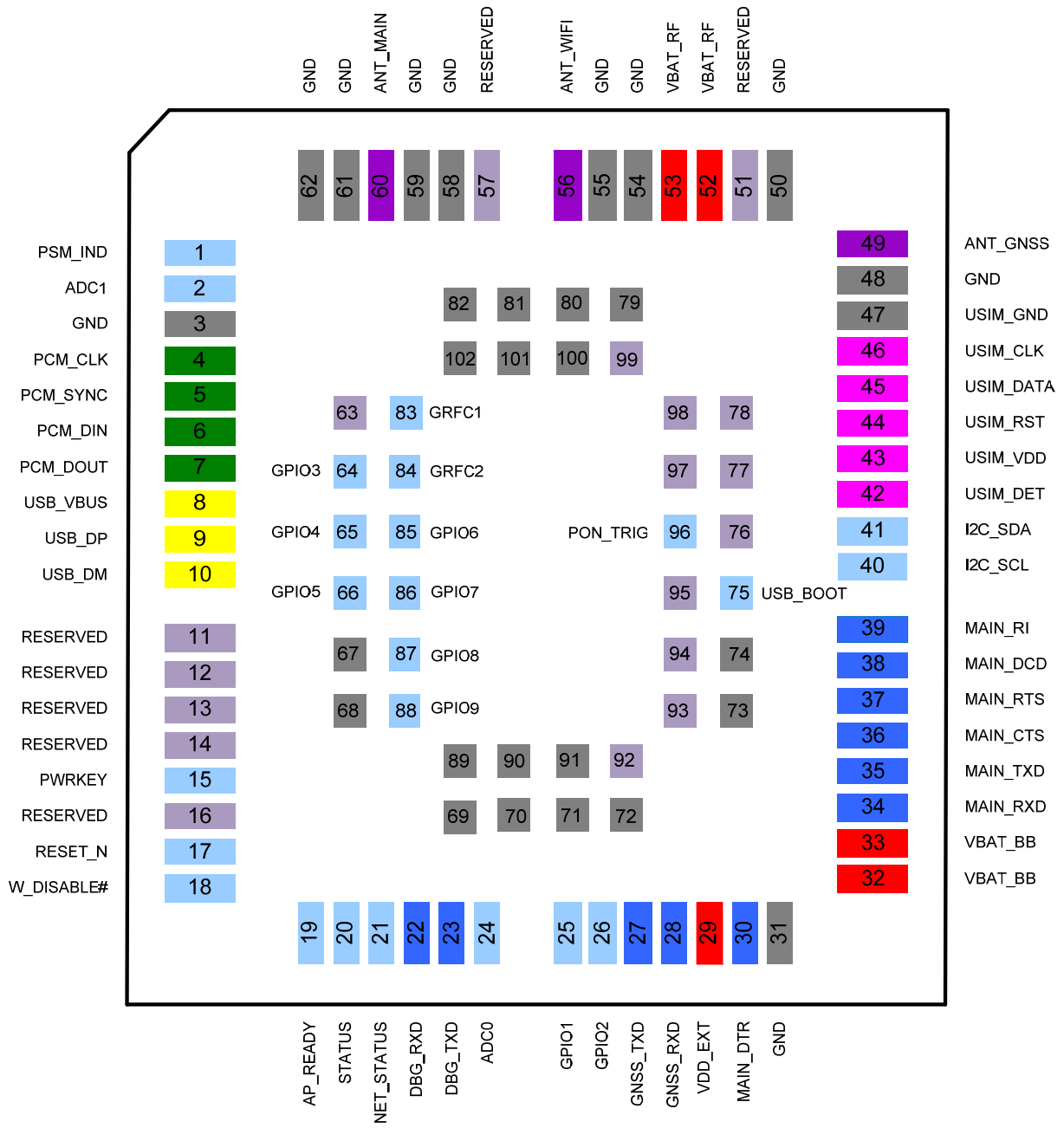

Figure 2: Pin Assignment (Top View)

NOTES

- 1) Only BG95-MF supports ANT_WIFI (pin 56).

2. ²⁾ BG95-MF does not support GPIO3 and GPIO4 interfaces (pin 64 and pin 65).
3. ³⁾ BG95-M4 does not support GRFC interfaces (pin 83 and pin 84).
4. Do not use ADC0 and ADC1 simultaneously, as ADC1 connects directly to ADC0 inside the module. BG95 series module supports use of only one ADC interface at a time: either ADC0 or ADC1.
5. PWRKEY output voltage is 1.5 V because of the voltage drop inside the Qualcomm chipset. Due to platform limitations, the chipset has integrated the reset function into PWRKEY. Therefore, never pull down PWRKEY to GND permanently.
6. RESET_N connects directly to PWRKEY inside the module.
7. GNSS_TXD (pin 27) and GRFC2 (pin 84) are BOOT_CONFIG pins. Never pull them up before startup, otherwise the module cannot power on normally.
8. Keep all RESERVED pins and unused pins unconnected.
9. Connect GND pins to the ground in the design.

3.2. Pin Description

The following tables show the pin definition and description of BG95 series module.

Table 4: Definition of I/O Parameters

Type	Description
AI	Analog Input
AO	Analog Output
DI	Digital Input
DO	Digital Output
IO	Bidirectional
PI	Power Input
PO	Power Output

Table 5: Pin Description

Power Supply					
Pin Name	Pin No.	I/O	Description	DC Characteristics	Comment
VBAT_BB	32, 33	PI	Power supply for the module's baseband part	BG95-M1/-M2/-N1: V _{max} = 4.8 V V _{min} = 2.6 V V _{norm} = 3.3 V	See NOTE 1
				BG95-M3/-M5/-M6 V _{max} = 4.3 V V _{min} = 3.3 V V _{norm} = 3.8 V	
				BG95-M4: V _{max} = 4.2 V V _{min} = 3.2 V V _{norm} = 3.8 V	
				BG95-MF: V _{norm} = 3.8 V	
VBAT_RF	52, 53	PI	Power supply for the module's RF part	BG95-M1/-M2/-N1: V _{max} = 4.8 V V _{min} = 2.6 V V _{norm} = 3.3 V	See NOTE 1
				BG95-M3/-M5/-M6: V _{max} = 4.3 V V _{min} = 3.3 V V _{norm} = 3.8 V	
				BG95-M4: V _{max} = 4.2 V V _{min} = 3.2 V V _{norm} = 3.8 V	
				BG95-MF: V _{norm} = 3.8 V	
VDD_EXT	29	PO	1.8 V output power supply for external circuits	V _{norm} = 1.8 V I _{Omax} = 50 mA	If unused, keep this pin open
GND	3, 31, 48, 50, 54, 55,		Ground		

58, 59, 61,
 62, 67–74,
 79–82,
 89–91,
 100–102

Turn on/off

Pin Name	Pin No.	I/O	Description	DC Characteristics	Comment
PWRKEY	15	DI	Turns on/off the module	V _{norm} = 1.5 V V _{ILmax} = 0.45 V	Never pull down PWRKEY to GND permanently.

Reset

Pin Name	Pin No.	I/O	Description	DC Characteristics	Comment
RESET_N	17	DI	Resets the module	V _{norm} = 1.5 V V _{ILmax} = 0.45 V	

Status Indication

Pin Name	Pin No.	I/O	Description	DC Characteristics	Comment
PSM_IND	1	DO	Power saving mode indication	V _{OHmin} = 1.35 V V _{OLmax} = 0.45 V	1.8 V power domain. If unused, keep this pin open.
STATUS	20	DO	Module operation status indication	V _{OHmin} = 1.35 V V _{OLmax} = 0.45 V	1.8 V power domain. If unused, keep this pin open.
NET_STATUS	21	DO	Module network activity status indication	V _{OHmin} = 1.35 V V _{OLmax} = 0.45 V	1.8 V power domain. If unused, keep this pin open.

USB Interface

Pin Name	Pin No.	I/O	Description	DC Characteristics	Comment
USB_VBUS	8	AI	USB connection detection	V _{norm} = 5.0 V	Typical 5.0 V
USB_DP	9	IO	USB differential data (+)		Compliant with USB 2.0 standard specification.
USB_DM	10	IO	USB differential data (-)		Require differential impedance of 90 Ω.

(U)SIM Interface

Pin Name	Pin No.	I/O	Description	DC Characteristics	Comment
----------	---------	-----	-------------	--------------------	---------

USIM_DET	42	DI	(U)SIM card hot-plug detection	$V_{ILmin} = -0.3\text{ V}$ $V_{ILmax} = 0.6\text{ V}$ $V_{IHmin} = 1.2\text{ V}$ $V_{IHmax} = 2.0\text{ V}$	1.8 V power domain. If unused, keep this pin open.
USIM_VDD	43	PO	(U)SIM card power supply	$V_{max} = 1.9\text{ V}$ $V_{min} = 1.7\text{ V}$	Only 1.8 V (U)SIM card is supported.
USIM_RST	44	DO	(U)SIM card reset	$V_{OLmax} = 0.45\text{ V}$ $V_{OHmin} = 1.35\text{ V}$	
USIM_DATA	45	IO	(U)SIM card data	$V_{ILmin} = -0.3\text{ V}$ $V_{ILmax} = 0.6\text{ V}$ $V_{IHmin} = 1.2\text{ V}$ $V_{IHmax} = 2.0\text{ V}$ $V_{OLmax} = 0.45\text{ V}$ $V_{OHmin} = 1.35\text{ V}$	
USIM_CLK	46	DO	(U)SIM card clock	$V_{OLmax} = 0.45\text{ V}$ $V_{OHmin} = 1.35\text{ V}$	
USIM_GND	47		(U)SIM card ground		

Main UART Interface

Pin Name	Pin No.	I/O	Description	DC Characteristics	Comment
MAIN_DTR	30	DI	Main UART data terminal ready	$V_{ILmin} = -0.3\text{ V}$ $V_{ILmax} = 0.6\text{ V}$ $V_{IHmin} = 1.2\text{ V}$ $V_{IHmax} = 2.0\text{ V}$	1.8 V power domain. If unused, keep this pin open.
MAIN_RXD	34	DI	Main UART receive	$V_{ILmin} = -0.3\text{ V}$ $V_{ILmax} = 0.6\text{ V}$ $V_{IHmin} = 1.2\text{ V}$ $V_{IHmax} = 2.0\text{ V}$	1.8 V power domain. If unused, keep this pin open.
MAIN_TXD	35	DO	Main UART transmit	$V_{OLmax} = 0.45\text{ V}$ $V_{OHmin} = 1.35\text{ V}$	1.8 V power domain. If unused, keep this pin open.
MAIN_CTS	36	DO	Main UART clear to send	$V_{OLmax} = 0.45\text{ V}$ $V_{OHmin} = 1.35\text{ V}$	1.8 V power domain. If unused, keep this pin open.
MAIN_RTS	37	DI	Main UART request to send	$V_{ILmin} = -0.3\text{ V}$ $V_{ILmax} = 0.6\text{ V}$ $V_{IHmin} = 1.2\text{ V}$ $V_{IHmax} = 2.0\text{ V}$	1.8 V power domain. If unused, keep this pin open.
MAIN_DCD	38	DO	Main UART data carrier detect	$V_{OLmax} = 0.45\text{ V}$ $V_{OHmin} = 1.35\text{ V}$	1.8 V power domain. If unused, keep this pin open.

MAIN_RI	39	DO	Main UART ring indication	$V_{OLmax} = 0.45\text{ V}$ $V_{OHmin} = 1.35\text{ V}$	1.8 V power domain. If unused, keep this pin open.
Debug UART Interface					
Pin Name	Pin No.	I/O	Description	DC Characteristics	Comment
DBG_RXD	22	DI	Debug UART receive	$V_{ILmin} = -0.3\text{ V}$ $V_{ILmax} = 0.6\text{ V}$ $V_{IHmin} = 1.2\text{ V}$ $V_{IHmax} = 2.0\text{ V}$	1.8 V power domain. If unused, keep this pin open.
DBG_TXD	23	DO	Debug UART transmit	$V_{OLmax} = 0.45\text{ V}$ $V_{OHmin} = 1.35\text{ V}$	1.8 V power domain. If unused, keep this pin open.
GNSS UART Interface					
Pin Name	Pin No.	I/O	Description	DC Characteristics	Comment
GNSS_TXD	27	DO	GNSS UART transmit	$V_{OLmax} = 0.45\text{ V}$ $V_{OHmin} = 1.35\text{ V}$	BOOT_CONFIG. Do not pull it up before startup. 1.8 V power domain. If unused, keep this pin open.
GNSS_RXD	28	DI	GNSS UART receive	$V_{ILmin} = -0.3\text{ V}$ $V_{ILmax} = 0.6\text{ V}$ $V_{IHmin} = 1.2\text{ V}$ $V_{IHmax} = 2.0\text{ V}$	1.8 V power domain. If unused, keep this pin open.
PCM Interface*					
Pin Name	Pin No.	I/O	Description	DC Characteristics	Comment
PCM_CLK	4	DO	PCM clock	$V_{OLmax} = 0.45\text{ V}$ $V_{OHmin} = 1.35\text{ V}$	1.8 V power domain. If unused, keep this pin open.
PCM_SYNC	5	DO	PCM data frame sync	$V_{OLmax} = 0.45\text{ V}$ $V_{OHmin} = 1.35\text{ V}$	1.8 V power domain. If unused, keep this pin open.
PCM_DIN	6	DI	PCM data input	$V_{ILmin} = -0.3\text{ V}$ $V_{ILmax} = 0.6\text{ V}$ $V_{IHmin} = 1.2\text{ V}$ $V_{IHmax} = 2.0\text{ V}$	1.8 V power domain. If unused, keep this pin open.
PCM_DOUT	7	DO	PCM data output	$V_{OLmax} = 0.45\text{ V}$ $V_{OHmin} = 1.35\text{ V}$	1.8 V power domain. If unused, keep this pin open.

I2C Interface*

Pin Name	Pin No.	I/O	Description	DC Characteristics	Comment
I2C_SCL	40	OD	I2C serial clock (for external codec)		External pull-up resistor is required. 1.8 V only. If unused, keep this pin open.
I2C_SDA	41	OD	I2C serial data (for external codec)		External pull-up resistor is required. 1.8 V only. If unused, keep this pin open.

Antenna Interfaces

Pin Name	Pin No.	I/O	Description	DC Characteristics	Comment
ANT_MAIN	60	IO	Main antenna interface		50 Ω impedance
ANT_GNSS	49	AI	GNSS antenna interface		50 Ω impedance. If unused, keep this pin open.
ANT_WIFI* ¹⁾	56	AI	Wi-Fi antenna interface		50 Ω impedance. If unused, keep this pin open. Only BG95-MF supports the interface.

GPIO Interfaces

Pin Name	Pin No.	I/O	Description	DC Characteristics	Comment
GPIO1	25	IO	General-purpose input/output	V _{OL} max = 0.45 V V _{OH} min = 1.35 V V _{IL} min = -0.3 V V _{IL} max = 0.6 V V _{IH} min = 1.2 V V _{IH} max = 2.0 V	1.8 V power domain. If unused, keep this pin open.
GPIO2	26	IO	General-purpose input/output	V _{OL} max = 0.45 V V _{OH} min = 1.35 V V _{IL} min = -0.3 V V _{IL} max = 0.6 V V _{IH} min = 1.2 V V _{IH} max = 2.0 V	1.8 V power domain. If unused, keep this pin open.

GPIO3 ²⁾	64	IO	General-purpose input/output	$V_{OLmax} = 0.45\text{ V}$ $V_{OHmin} = 1.35\text{ V}$ $V_{ILmin} = -0.3\text{ V}$ $V_{ILmax} = 0.6\text{ V}$ $V_{IHmin} = 1.2\text{ V}$ $V_{IHmax} = 2.0\text{ V}$	1.8 V power domain. If unused, keep this pin open.
GPIO4 ²⁾	65	IO	General-purpose input/output	$V_{OLmax} = 0.45\text{ V}$ $V_{OHmin} = 1.35\text{ V}$ $V_{ILmin} = -0.3\text{ V}$ $V_{ILmax} = 0.6\text{ V}$ $V_{IHmin} = 1.2\text{ V}$ $V_{IHmax} = 2.0\text{ V}$	1.8 V power domain. If unused, keep this pin open.
GPIO5	66	IO	General-purpose input/output	$V_{OLmax} = 0.45\text{ V}$ $V_{OHmin} = 1.35\text{ V}$ $V_{ILmin} = -0.3\text{ V}$ $V_{ILmax} = 0.6\text{ V}$ $V_{IHmin} = 1.2\text{ V}$ $V_{IHmax} = 2.0\text{ V}$	1.8 V power domain. If unused, keep this pin open.
GPIO6	85	IO	General-purpose input/output	$V_{OLmax} = 0.45\text{ V}$ $V_{OHmin} = 1.35\text{ V}$ $V_{ILmin} = -0.3\text{ V}$ $V_{ILmax} = 0.6\text{ V}$ $V_{IHmin} = 1.2\text{ V}$ $V_{IHmax} = 2.0\text{ V}$	1.8 V power domain. If unused, keep this pin open.
GPIO7	86	IO	General-purpose input/output	$V_{OLmax} = 0.45\text{ V}$ $V_{OHmin} = 1.35\text{ V}$ $V_{ILmin} = -0.3\text{ V}$ $V_{ILmax} = 0.6\text{ V}$ $V_{IHmin} = 1.2\text{ V}$ $V_{IHmax} = 2.0\text{ V}$	1.8 V power domain. If unused, keep this pin open.
GPIO8	87	IO	General-purpose input/output	$V_{OLmax} = 0.45\text{ V}$ $V_{OHmin} = 1.35\text{ V}$ $V_{ILmin} = -0.3\text{ V}$ $V_{ILmax} = 0.6\text{ V}$ $V_{IHmin} = 1.2\text{ V}$ $V_{IHmax} = 2.0\text{ V}$	1.8 V power domain. If unused, keep this pin open.
GPIO9	88	IO	General-purpose input/output	$V_{OLmax} = 0.45\text{ V}$ $V_{OHmin} = 1.35\text{ V}$ $V_{ILmin} = -0.3\text{ V}$ $V_{ILmax} = 0.6\text{ V}$ $V_{IHmin} = 1.2\text{ V}$ $V_{IHmax} = 2.0\text{ V}$	1.8 V power domain. If unused, keep this pin open.

ADC Interfaces

Pin Name	Pin No.	I/O	Description	DC Characteristics	Comment
ADC0	24	AI	General-purpose ADC interface	Voltage range: 0.1–1.8 V	Do not use ADC0 and ADC1 simultaneously.
ADC1	2	AI	General-purpose ADC interface	Voltage range: 0.1–1.8 V	If unused, keep these pins open.
Other Interface Pins					
Pin Name	Pin No.	I/O	Description	DC Characteristics	Comment
W_DISABLE#*	18	DI	Airplane mode control	$V_{ILmin} = -0.3\text{ V}$ $V_{ILmax} = 0.6\text{ V}$ $V_{IHmin} = 1.2\text{ V}$ $V_{IHmax} = 2.0\text{ V}$	1.8 V power domain. Pulled up by default. When it is in low voltage level, the module can enter airplane mode. If unused, keep this pin open.
AP_READY*	19	DI	Application processor sleep state detection	$V_{ILmin} = -0.3\text{ V}$ $V_{ILmax} = 0.6\text{ V}$ $V_{IHmin} = 1.2\text{ V}$ $V_{IHmax} = 2.0\text{ V}$	1.8 V power domain. If unused, keep this pin open.
USB_BOOT	75	DI	Force the module into emergency download mode	$V_{ILmin} = -0.3\text{ V}$ $V_{ILmax} = 0.6\text{ V}$ $V_{IHmin} = 1.2\text{ V}$ $V_{IHmax} = 2.0\text{ V}$	1.8 V power domain. If unused, keep this pin open.
PON_TRIG	96	DI	Wake up the module from PSM		1.8 V power domain. Rising-edge triggered. Pulled-down by default. If unused, keep this pin open.
GRFC Interfaces					
Pin Name	Pin No.	I/O	Description	DC Characteristics	Comment
GRFC1 ³⁾	83	DO	Generic RF controller	$V_{OLmax} = 0.45\text{ V}$ $V_{OHmin} = 1.35\text{ V}$	1.8 V power domain. If unused, keep this pin open.
GRFC2 ³⁾	84	DO	Generic RF controller	$V_{OLmax} = 0.45\text{ V}$ $V_{OHmin} = 1.35\text{ V}$	BOOT_CONFIG. Do not pull it up before startup. 1.8 V power domain.

If unused, keep this pin open.

RESERVED Pins

Pin Name	Pin No.	I/O	Description	DC Characteristics	Comment
RESERVED	11–14, 16, 51, 57, 63, 76–78, 92–95, 97–99		Reserved		Keep these pins open.

NOTES

- ¹⁾ Only BG95-MF supports ANT_WIFI (pin 56).
- ²⁾ BG95-MF does not support GPIO3 and GPIO4 interfaces (pin 64 and pin 65).
- ³⁾ BG95-M4 does not support GRFC interfaces (pin 83 and pin 84).
- For every VBAT transition/re-insertion from 0 V, the minimum power supply voltage should be higher than 2.7 V. After the module starts up normally, the minimum safety voltage is 2.6 V. In order to ensure full-function mode, the minimum power supply voltage should be higher than 2.8 V.
- PWRKEY output voltage is 1.5 V because of the voltage drop inside the Qualcomm chipset. Due to platform limitations, the chipset has integrated the reset function into PWRKEY. Therefore, never pull down PWRKEY to GND permanently.
- RESET_N connects directly to PWRKEY inside the module.
- Do not use ADC0 and ADC1 simultaneously, as ADC1 connects directly to ADC0 inside the module. BG95 series module supports use of only one ADC interface at a time: either ADC0 or ADC1.
- When PSM is enabled, the function of PSM_IND pin will be activated after the module is rebooted. When PSM_IND is in high voltage level, the module is in normal operation state, when it is in low voltage level, the module is in PSM.
- GNSS_TXD (pin 27) and GRFC2 (pin 84) are BOOT_CONFIG pins. Never pull them up before startup, otherwise the module cannot power on normally.
- Keep all RESERVED pins and unused pins open.
- “*” means under development.

3.3. Operating Modes

The table below briefly summarizes the various operating modes of BG95 series module.

Table 6: Overview of BG95 Operating Modes

Mode	Details
Normal Operation	Connected Network has been connected. In this mode, the power consumption may vary with the network setting and data transfer rate.
	Idle Software is active. The module remains registered on network, and it is ready to send and receive data.
Extended Idle Mode DRX (e-I-DRX)	BG95 module and the network may negotiate over non-access stratum signaling the use of e-I-DRX for reducing power consumption, while being available for mobile terminating data and/or network originated procedures within a certain delay dependent on the DRX cycle value.
Airplane Mode	AT+CFUN=4 or W_DISABLE#* pin can set the module into airplane mode. In this case, RF function is invalid.
Minimum Functionality Mode	AT+CFUN=0 can set the module into a minimum functionality mode without removing the power supply. In this case, both RF function and (U)SIM card are invalid.
Sleep Mode	In this mode, the current consumption of the module is reduced to a lower level. During this mode, the module can still receive paging message, SMS and TCP/UDP data from the network normally.
Power OFF Mode	In this mode, the power management unit shuts down the power supply. The software is not active. The serial interfaces are not accessible. But the operating voltage (connected to VBAT_RF and VBAT_BB) remains applied.
Power Saving Mode (PSM)	The module may enter PSM to reduce its power consumption. PSM is similar to power-off, but the module remains registered on the network and there is no need to re-attach or re-establish PDN connections.

NOTES

1. During e-I-DRX, it is recommended to use UART interface for data communication, as the use of USB interface increases power consumption.
2. "*" means under development.

3.4. Power Saving

3.4.1. Airplane Mode

When the module enters airplane mode, the RF function does not work, and all AT commands correlative with RF function are inaccessible. This mode can be set via the following ways.

Hardware:

W_DISABLE#* is pulled up by default. Driving it low makes the module enter airplane mode.

Software:

AT+CFUN=<fun> provides choice of the functionality level, through setting <fun> into 0, 1 or 4.

- **AT+CFUN=0**: Minimum functionality mode. Both (U)SIM and RF functions are disabled.
- **AT+CFUN=1**: Full functionality mode (by default).
- **AT+CFUN=4**: Airplane mode. RF function is disabled.

NOTES

1. Airplane mode control via W_DISABLE# is disabled in firmware by default. It can be enabled by **AT+QCFG="airplanecontrol"** command which is still under development. See **document [2]** for the details about the command.
2. The execution of **AT+CFUN** command will not affect GNSS function.
3. "*" means under development.

3.4.2. Power Saving Mode (PSM)

BG95 module can enter PSM to reduce its power consumption. The mode is similar to power-off, but the module remains registered on the network and there is no need to re-attach or re-establish PDN connections. So BG95 in PSM cannot immediately respond users' requests.

When the module wants to use the PSM it shall request an Active Time value during every Attach and TAU procedures. If the network supports PSM and accepts that the module uses PSM, it will confirm the usage of PSM by allocating an Active Time value to the module. If the module wants to change the Active Time value, e.g. when the conditions are changed in the module, the module consequently requests the value it wants in the TAU procedure.

If PSM is supported by the network, then it can be enabled via **AT+CPSMS** command.

Either of the following methods can wake up the module from PSM:

- Wake up the module from PSM through a rising edge on PON_TRIG. (Recommended)
- Wake up the module by driving PWRKEY low.
- The module is woken up automatically when the T3412_Ext timer expires.

NOTE

See **document [2]** for details about **AT+CPSMS** command.

3.4.3. Extended Idle Mode DRX (e-I-DRX)

The module (UE) and the network may negotiate over non-access stratum signalling the use of e-I-DRX for reducing its power consumption, while being available for mobile terminating data and/or network originated procedures within a certain delay dependent on the DRX cycle value.

Applications that want to use e-I-DRX need to consider specific handling of mobile terminating services or data transfers, and in particular they need to consider the delay tolerance of mobile terminated data.

In order to negotiate the use of e-I-DRX, the UE requests e-I-DRX parameters during attach procedure and RAU/TAU procedure. The EPC may reject or accept the UE request for enabling e-I-DRX. In case the EPC accepts e-I-DRX, the EPC based on operator policies and, if available, the e-I-DRX cycle length value in the subscription data from the HSS, may also provide different values of the e-I-DRX parameters than what was requested by the UE. If the EPC accepts the use of e-I-DRX, the UE applies e-I-DRX based on the received e-I-DRX parameters. If the UE does not receive e-I-DRX parameters in the relevant accept message because the EPC rejected its request or because the request was received by EPC not supporting e-I-DRX, the UE shall apply its regular discontinuous reception.

If e-I-DRX is supported by the network, then it can be enabled by **AT+CEDRXS=1** command.

NOTE

See *document [2]* for details about **AT+CEDRXS** command.

3.4.4. Sleep Mode

BG95 is able to reduce its current consumption to a lower value during the sleep mode. The following sub-chapters describe the power saving procedure of BG95 series module.

3.4.4.1. UART Application

If the host communicates with the module via UART interface, the following preconditions can let the module enter sleep mode.

- Execute **AT+QSCLK=1** command to enable sleep mode.
- Drive MAIN_DTR pin high.

The following figure shows the connection between the module and the host.

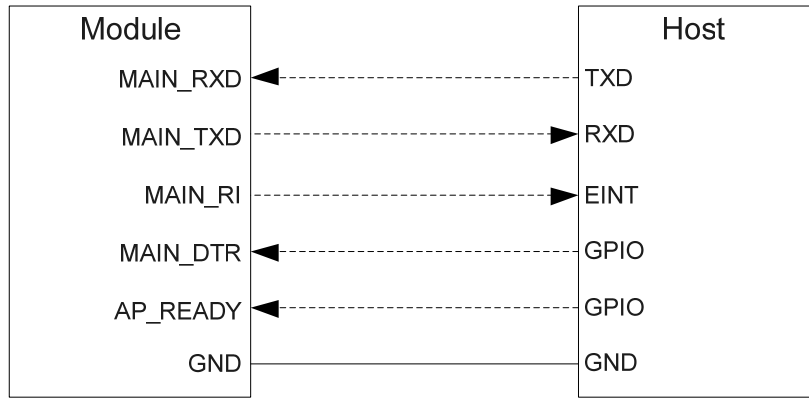

Figure 3: Sleep Mode Application via UART

- When the module has URC to report, MAIN_RI signal wakes up the host. See **Chapter 3.15** for details about MAIN_RI behavior.
- Driving MAIN_DTR low wakes up the module.
- AP_READY* detects the sleep state of the host (can be configured to high level or low level detection). See **AT+QCFG="apready"** command in **document [2]** for details.

NOTE

"*" means under development.

3.5. Power Supply

3.5.1. Power Supply Pins

BG95 provides the following four VBAT pins for connection with an external power supply. There are two separate voltage domains for VBAT.

- Two VBAT_RF pins for module's RF part.
- Two VBAT_BB pins for module's baseband part.

The following table shows the details of VBAT pins and ground pins.

Table 7: VBAT and GND Pins

Pin Name	Pin No.	Description	Module	Min.	Typ.	Max.	Unit
VBAT_RF	52, 53	Power supply for the module's RF part	BG95-M1/-M2/-N1 ¹⁾	2.6	3.3	4.8	V
			BG95-M3/-M5/-M6	3.3	3.8	4.3	V
			BG95-M4	3.2	3.8	4.2	V
			BG95-MF	TBD	3.8	TBD	V
VBAT_BB	32, 33	Power supply for the module's baseband part	BG95-M1/-M2/-N1 ¹⁾	2.6	3.3	4.8	V
			BG95-M3/-M5/-M6	3.3	3.8	4.3	V
			BG95-M4	3.2	3.8	4.2	V
			BG95-MF	TBD	3.8	TBD	V
GND	3, 31, 48, 50, 54, 55, 58, 59, 61, 62, 67–74, 79–82, 89–91, 100–102	Ground		-	-	-	-

NOTE

¹⁾ For every VBAT transition/re-insertion from 0 V, the minimum power supply voltage should be higher than 2.7 V. After the module starts up normally, the minimum safety voltage is 2.6 V. In order to ensure full-function mode, the minimum power supply voltage should be higher than 2.8 V.

3.5.2. Decrease Voltage Drop

- **BG95-M1/-M2/-N1:** The power supply range of BG95-M1/-M2/-N1 is 2.6–4.8 V. For every VBAT transition/re-insertion from 0 V, the minimum power supply voltage should be higher than 2.7 V. After the module starts up normally, the minimum safety voltage is 2.6 V. In order to ensure full-function mode, the minimum power supply voltage should be higher than 2.8 V. Ensure the input voltage never drop below 2.6 V.
- **BG95-M3/-M5/-M6:** The power supply range of BG95-M3/-M5/-M6 is from 3.3–4.3 V. Please assure the input voltage will never drop below 3.3 V.
- **BG95-M4:** The power supply range of BG95-M4 is from 3.2–4.2 V. Ensure the input voltage never

drop below 3.2 V.

- **BG95-MF:** The typical power supply of BG95-MF is 3.8 V.

The following figure shows the voltage drop during burst transmission in 2G network of BG95-M3/-M5. The voltage drop is less in LTE Cat M1 and/or LTE Cat NB2 networks.

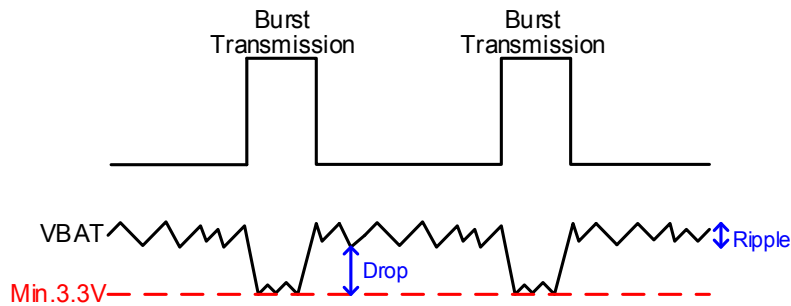

Figure 4: Power Supply Limits during Burst Transmission (BG95-M3/-M5)

To decrease voltage drop, a bypass capacitor of about 100 μF with low ESR should be used, and a multi-layer ceramic chip capacitor (MLCC) array should also be reserved due to its low ESR. It is recommended to use three ceramic capacitors (100 nF, 33 pF, 10 pF) for composing the MLCC array, and place these capacitors close to VBAT pins. The main power supply from an external application has to be a single voltage source and can be expanded to two sub paths with star structure. The width of VBAT_BB trace should be no less than 0.6 mm, and the width of VBAT_RF trace should be no less than 2 mm. In principle, the longer the VBAT trace is, the wider it will be.

In addition, in order to get a stable power source, it is suggested to use a TVS with low leakage current and suitable reverse stand-off voltage, and also it is recommended to place it as close to the VBAT pins as possible. The following figure shows the star structure of the power supply.

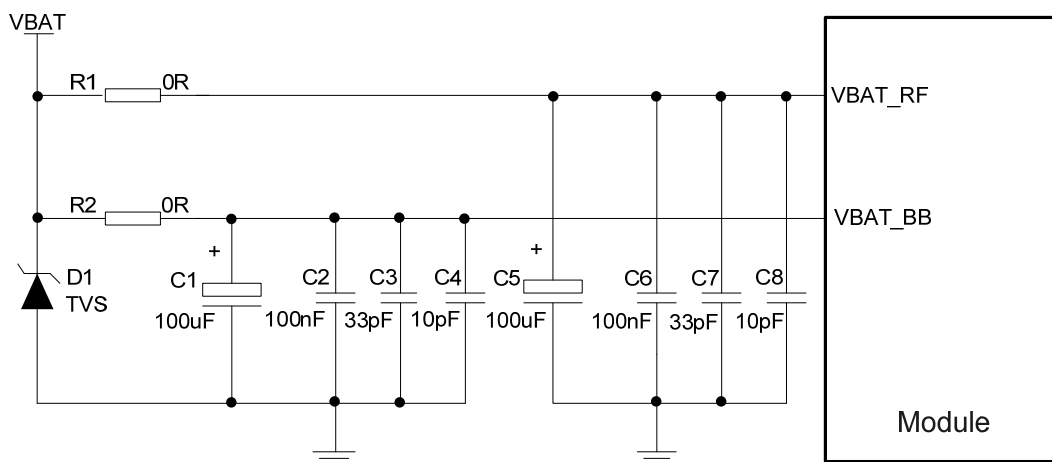

Figure 5: Star Structure of the Power Supply

3.5.3. Monitor the Power Supply

AT+CBC command can be used to monitor the VBAT_BB voltage value. For more details, see [document \[2\]](#).

3.6. Turn on and off Scenarios

3.6.1. Turn on Module Using the PWRKEY Pin

The following table shows the pin definition of PWRKEY.

Table 8: Pin Definition of PWRKEY

Pin Name	Pin No.	Description	DC Characteristics	Comment
PWRKEY	15	Turns on/off the module	Vnorm = 1.5 V V _{IL} max = 0.45 V	The output voltage is 1.5 V because of the voltage drop inside the Qualcomm chipset.

When BG95 is in power off mode, it can be turned on by driving PWRKEY low for 500–1000 ms. It is recommended to use an open drain/collector driver to control the PWRKEY. A simple reference circuit is illustrated in the following figure.

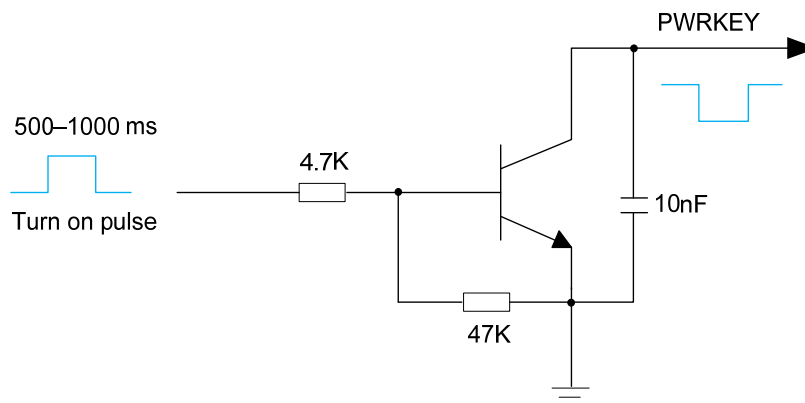

Figure 6: Turn on the Module Using Driving Circuit

Another way to control the PWRKEY is using a button directly. When pressing the key, electrostatic strike may generate from the finger. Therefore, a TVS component is indispensable to be placed nearby the button for ESD protection. A reference circuit is shown in the following figure.

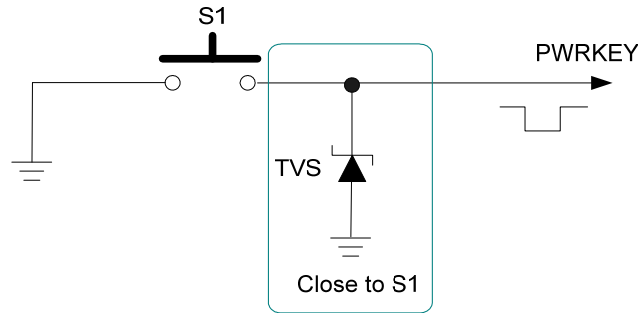

Figure 7: Turn on the Module Using Keystroke

The power on scenario is illustrated in the following figure.

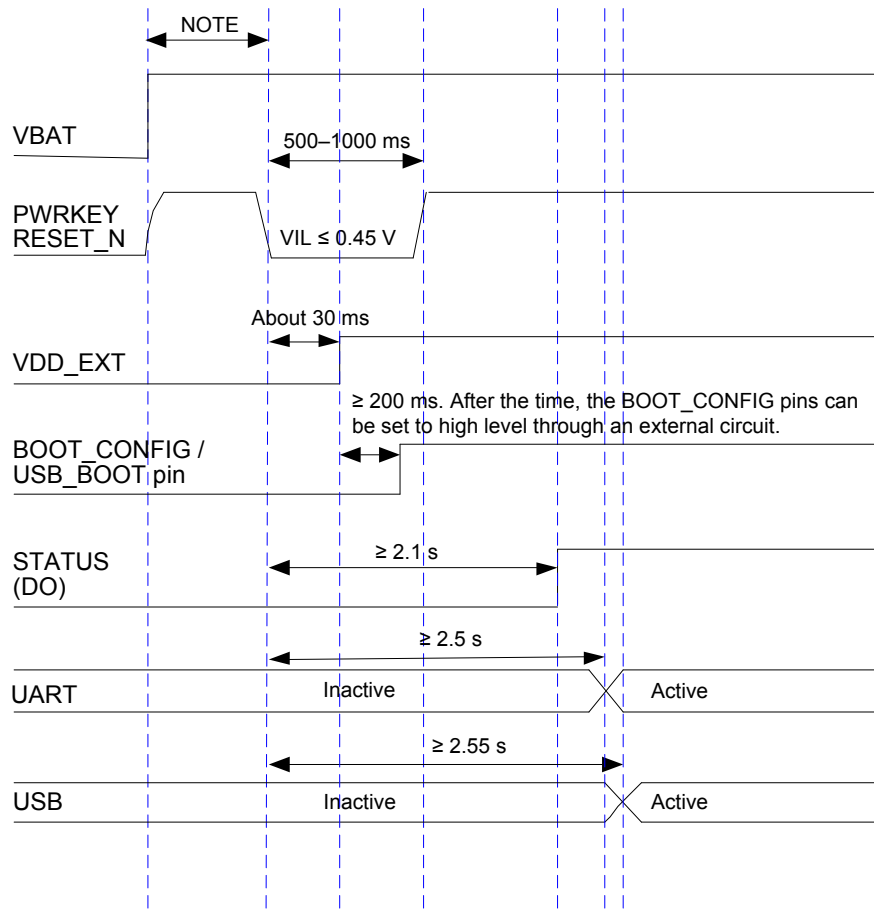

Figure 8: Power-on Timing

NOTES

1. Make sure that VBAT is stable before pulling down PWRKEY pin and keep the interval no less than 30 ms.

- PWRKEY output voltage is 1.5 V because of the voltage drop inside the Qualcomm chipset. Due to platform limitations, the chipset has integrated the reset function into PWRKEY. Therefore, never pull down PWRKEY to GND permanently.

3.6.2. Turn off Module

Either of the following methods can be used to turn off the module:

- Turn off the module through PWRKEY.
- Turn off the module through **AT+QPOWD** command.

3.6.2.1. Turn off Module through PWRKEY

Driving PWRKEY low for 650–1500 ms and then release it, the module will execute power-down procedure.

The power-off scenario is illustrated in the following figure.

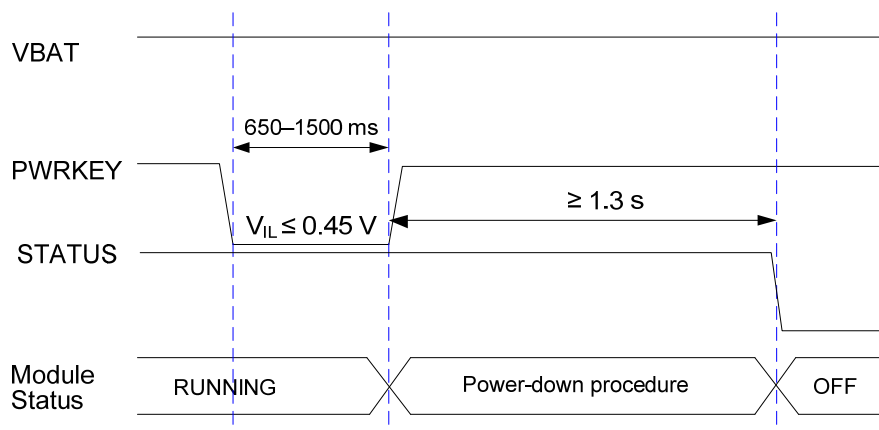

Figure 9: Power-off Timing

3.6.2.2. Turn off Module through AT Command

It is also a safe way to use **AT+QPOWD** command to turn off the module, which is similar to turning off the module via PWRKEY.

See *document [2]* for details about **AT+QPOWD** command.

3.7. Reset the Module

RESET_N is used to reset the module. Due to platform limitations, the chipset has integrated the reset function into PWRKEY, and RESET_N connects directly to PWRKEY inside the module.

The module can be reset by driving RESET_N low for 2–3.8 s.

Table 9: Pin Definition of RESET_N

Pin Name	Pin No.	Description	DC Characteristics	Comment
RESET_N	17	Resets the module	$V_{ILmax} = 0.45\text{ V}$	Multiplexed from PWRKEY (connected directly to PWRKEY inside the module).

The reset scenario is illustrated in the following figure.

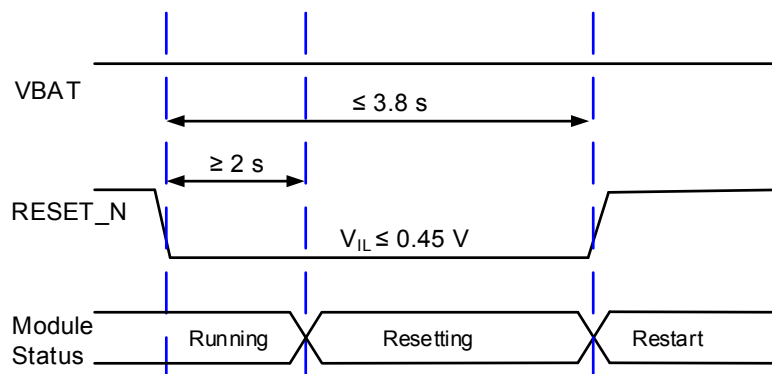

Figure 10: Reset Timing

The recommended circuit is similar to the PWRKEY control circuit. An open drain/collector driver or button can be used to control the RESET_N pin.

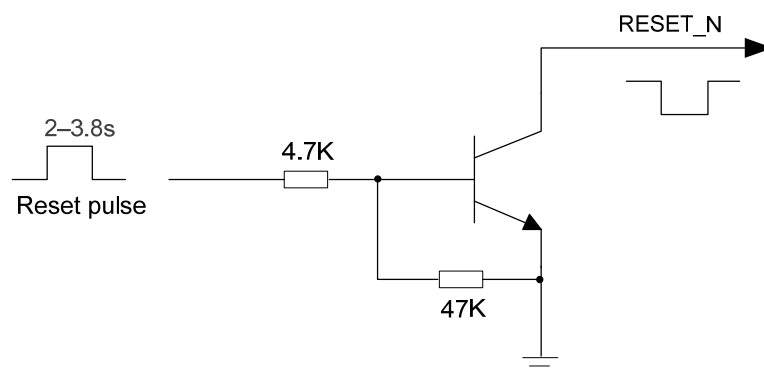

Figure 11: Reference Circuit of RESET_N by Using Driving Circuit

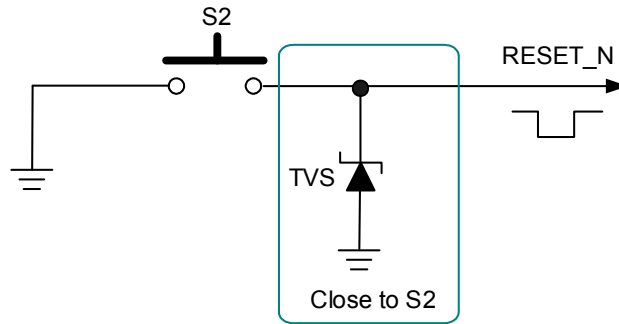

Figure 12: Reference Circuit of RESET_N by Using Button

NOTE

Please assure that there is no large capacitance on RESET_N pin.

3.8. PON_TRIG Interface

BG95 provides one PON_TRIG pin which is used to wake up the module from PSM. When the pin detects a rising edge, the module is woken up from PSM.

Table 10: Pin Definition of PON_TRIG Interface

Pin Name	Pin No.	I/O	Description	Comment
PON_TRIG	96	DI	Wake up the module from PSM	Rising-edge triggered. Pulled-down by default. 1.8 V power domain.

A reference circuit is shown in the following figure.

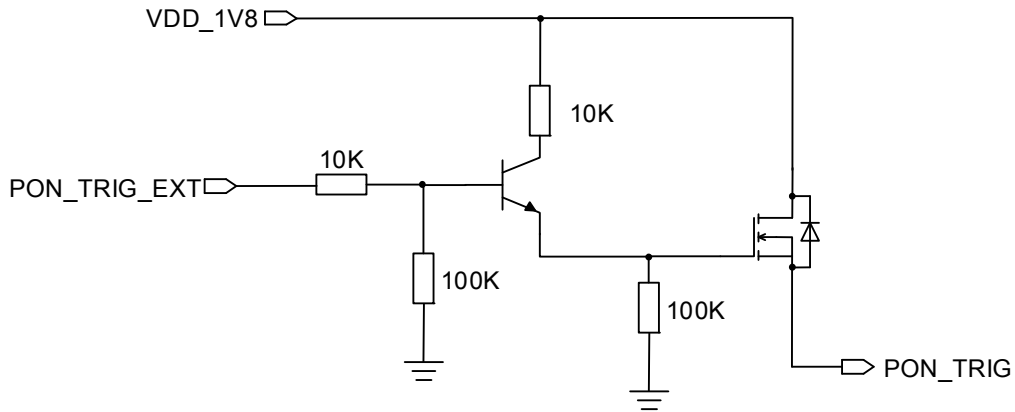

Figure 13: Reference Circuit of PON_TRIG

NOTE

VDD_1V8 is provided by an external LDO.

3.9. (U)SIM Interface

BG95 supports 1.8 V (U)SIM card only. The (U)SIM interface circuitry meets ETSI and IMT-2000 requirements.

Table 11: Pin Definition of (U)SIM Interface

Pin Name	Pin No.	I/O	Description	Comment
USIM_DET	42	DI	(U)SIM card hot-plug detection	1.8 V power domain.
USIM_VDD	43	PO	(U)SIM card power supply	Only 1.8 V (U)SIM card is supported.
USIM_RST	44	DO	(U)SIM card reset	1.8 V power domain.
USIM_DATA	45	IO	(U)SIM card data	1.8 V power domain.
USIM_CLK	46	DO	(U)SIM card clock	1.8 V power domain.
USIM_GND	47		(U)SIM card ground	

BG95 supports (U)SIM card hot-plug via the USIM_DET pin, and both high and low level detections are supported. The function is disabled by default, and see **AT+QSIMDET** command in **document [2]** for more details.

The following figure shows a reference design of (U)SIM interface with an 8-pin (U)SIM card connector.

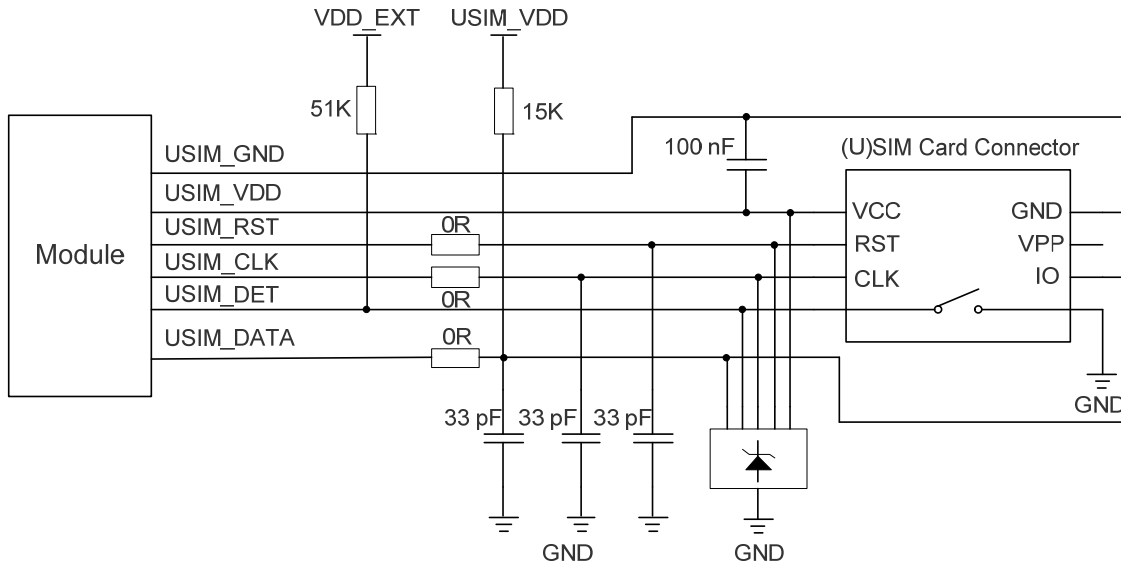

Figure 14: Reference Circuit of (U)SIM Interface with an 8-Pin (U)SIM Card Connector

If (U)SIM card detection function is not needed, please keep USIM_DET unconnected. A reference circuit for (U)SIM interface with a 6-pin (U)SIM card connector is illustrated in the following figure.

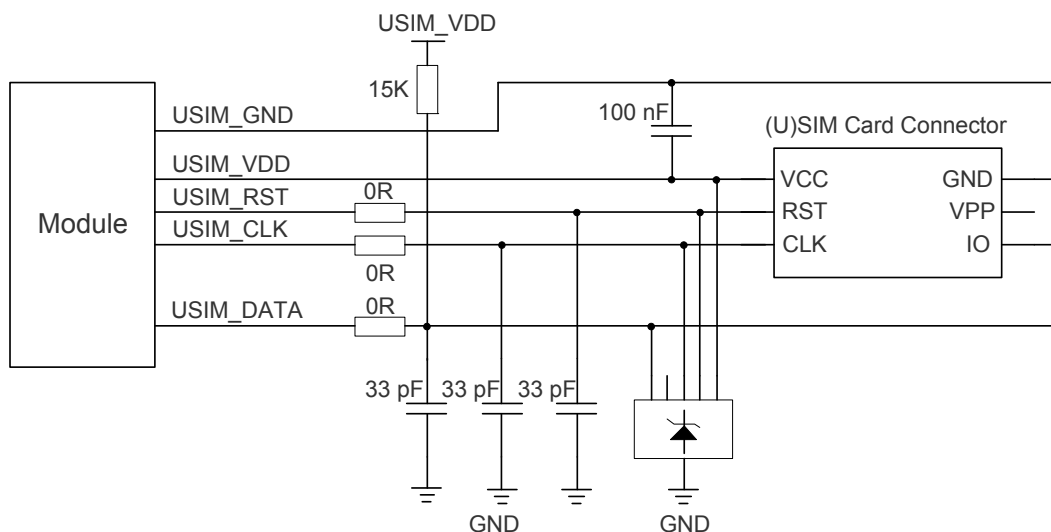

Figure 15: Reference Circuit of (U)SIM Interface with a 6-Pin (U)SIM Card Connector

In order to enhance the reliability and availability of the (U)SIM card in applications, please follow the criteria below in (U)SIM circuit design:

- Keep the placement of (U)SIM card connector as close to the module as possible. Keep the trace length as less than 200 mm as possible.
- Keep (U)SIM card signals away from RF and VBAT traces.
- Assure the ground between the module and the (U)SIM card connector short and wide. Keep the trace width of ground and USIM_VDD no less than 0.5 mm to maintain the same electric potential. Make sure the bypass capacitor between USIM_VDD and USIM_GND less than 1 μ F, and place it as close to (U)SIM card connector as possible. If the system ground plane is complete, USIM_GND can be connected to the system ground directly.
- To avoid cross-talk between USIM_DATA and USIM_CLK, keep them away from each other and shield them with surrounded ground. USIM_RST should also be ground shielded.
- In order to offer good ESD protection, it is recommended to add a TVS diode array with parasitic capacitance not exceeding 15 pF. In order to facilitate debugging, it is recommended to reserve series resistors for the (U)SIM signals of the module. The 33 pF capacitors are used for filtering interference of EGSM900. Please note that the (U)SIM peripheral circuit should be close to the (U)SIM card connector.
- The pull-up resistor on USIM_DATA line can improve anti-jamming capability when long layout trace and sensitive occasion are applied, and should be placed close to the (U)SIM card connector.

NOTES

1. eSIM function is optional. If eSIM is selected, then the external (U)SIM cannot be used simultaneously.
2. BG95-M5 and BG95-M6 do not support eSIM.

3.10. USB Interface

BG95 contains one integrated Universal Serial Bus (USB) interface which complies with the USB 2.0 specification and supports operation at low-speed (1.5 Mbps) and full-speed (12 Mbps) modes. The USB interface is used for AT command communication, data transmission, software debugging and firmware upgrade. The following table shows the pin definition of USB interface.

Table 12: Pin Definition of USB Interface

Pin Name	Pin No.	I/O	Description	Comment
USB_VBUS	8	AI	USB connection detection	Typical 5.0 V
USB_DP	9	IO	USB differential data (+)	Require differential impedance of 90 Ω
USB_DM	10	IO	USB differential data (-)	

GND	3	Ground
-----	---	--------

For more details about USB 2.0 specification, please visit <https://www.usb.org/>.

The USB interface is recommended to be reserved for firmware upgrade in application designs. The following figure shows a reference design of USB interface.

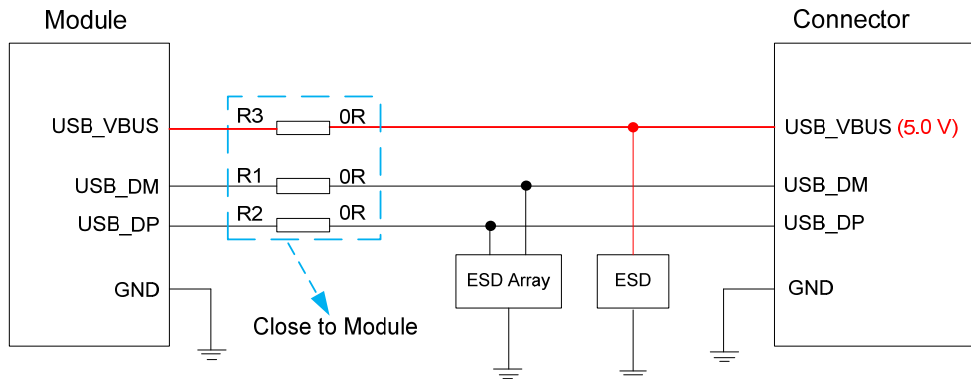

Figure 16: Reference Design of USB Interface

In order to ensure the integrity of USB data line signal, components R1 and R2 should be placed close to the module. The extra stubs of trace must be as short as possible.

The following principles should be complied with while designing the USB interface, so as to meet USB 2.0 specification.

- It is important to route the USB signal traces as differential pairs with ground surrounded. The impedance of USB differential trace is 90 Ω.
- Do not route signal traces under crystals, oscillators, magnetic devices and RF signal traces. It is important to route the USB differential traces in inner-layer of the PCB, and surround the traces with ground on that layer and with ground planes above and below.
- Junction capacitance of the ESD protection device might cause influences on USB data lines, so please pay attention to the selection of the device. Typically, the stray capacitance should be less than 2 pF.
- Keep the ESD protection devices as close to the USB connector as possible.

NOTE

BG95 can only be used as a slave device.

3.11. UART Interfaces

The module provides three UART interfaces: the main UART, debug UART and the GNSS UART interfaces. Features of them are illustrated below:

- The main UART interface supports 9600 bps, 19200 bps, 38400 bps, 57600 bps, 115200 bps, 230400 bps, 460800 bps and 921600 bps baud rates, and the default is 115200 bps. It is used for data transmission and AT command communication, and supports RTS and CTS hardware flow control. The default frame format is 8N1 (8 data bits, no parity, 1 stop bit).
- The debug UART interface supports a fixed baud rate of 115200 bps, and is used for software debugging and log output.
- The GNSS UART interface supports 115200 bps baud rate by default, and is used for GNSS data and NMEA sentences output.

The following tables show the pin definition of the three UART interfaces.

Table 13: Pin Definition of Main UART Interface

Pin Name	Pin No.	I/O	Description	Comment
MAIN_DTR	30	DI	Main UART data terminal ready	1.8 V power domain
MAIN_RXD	34	DI	Main UART receive	1.8 V power domain
MAIN_TXD	35	DO	Main UART transmit	1.8 V power domain
MAIN_CTS	36	DO	Main UART clear to send	1.8 V power domain
MAIN_RTS	37	DI	Main UART request to send	1.8 V power domain
MAIN_DCD	38	DO	Main UART data carrier detect	1.8 V power domain
MAIN_RI	39	DO	Main UART ring indication	1.8 V power domain

NOTE

AT+IPR command can be used to set the baud rate of the main UART interface, and **AT+IFC** command can be used to set the hardware flow control (the function is disabled by default). See **document [2]** for more details about these AT commands.

Table 14: Pin Definition of Debug UART Interface

Pin Name	Pin No.	I/O	Description	Comment
DBG_RXD	22	DI	Debug UART receive	1.8 V power domain
DBG_TXD	23	DO	Debug UART transmit	1.8 V power domain

Table 15: Pin Definition of GNSS UART Interface

Pin Name	Pin No.	I/O	Description	Comment
GNSS_TXD	27	DO	GNSS UART transmit	BOOT_CONFIG. Do not pull it up before startup. 1.8 V power domain
GNSS_RXD	28	DI	GNSS UART receive	1.8 V power domain

NOTE

GNSS_TXD is a BOOT_CONFIG pin. Never pull it up before startup, otherwise the module cannot power on normally.

The logic levels of UART interfaces are described in the following table.

Table 16: Logic Levels of Digital I/O

Parameter	Min.	Max.	Unit
V_{IL}	-0.3	0.6	V
V_{IH}	1.2	2.0	V
V_{OL}	0	0.45	V
V_{OH}	1.35	1.8	V

The module provides 1.8 V UART interfaces. A voltage-level translator should be used if customers' application is equipped with a 3.3 V UART interface. The voltage-level translator TXS0108EPWR provided by *Texas Instruments* is recommended. The following figure shows a reference design of the main UART interface.

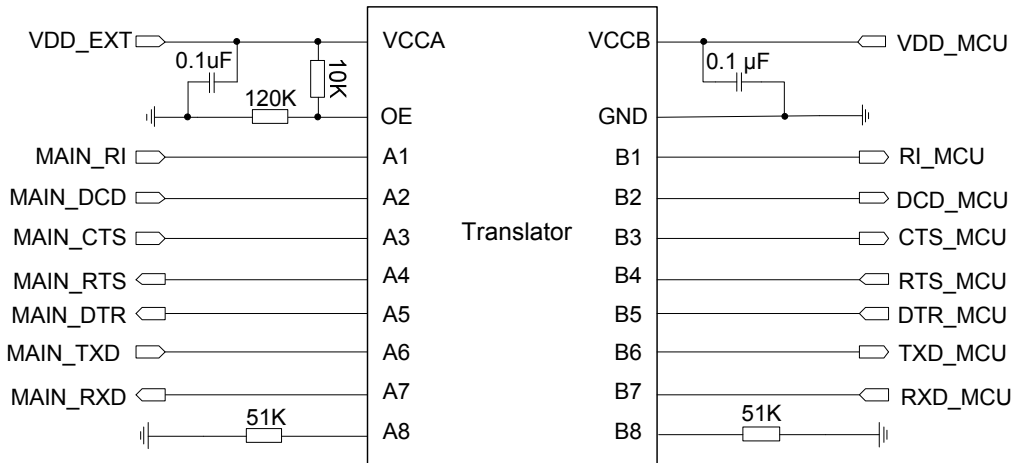

Figure 17: Main UART Reference Design (Translator Chip)

Please visit <http://www.ti.com/> for more information.

Another example with transistor translation circuit is shown as below. For the design of circuits in dotted lines, see that of circuits in solid lines, but please pay attention to the direction of connection.

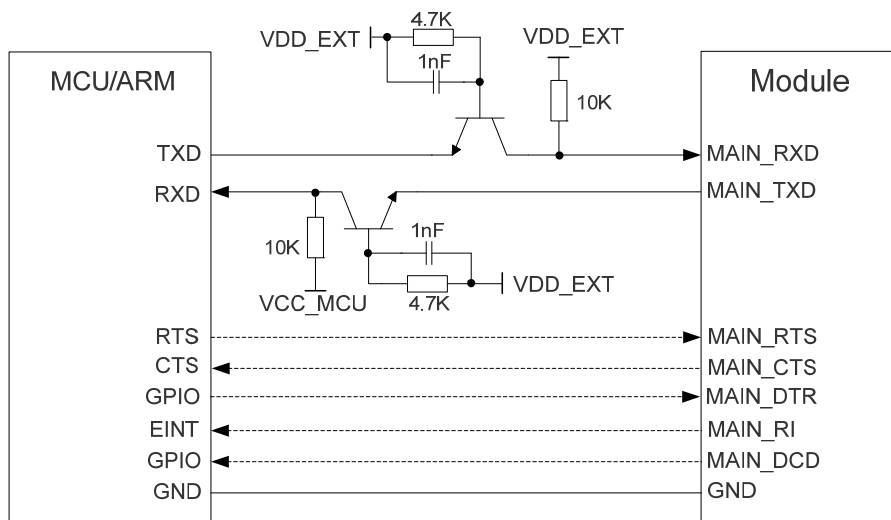

Figure 18: Main UART Reference Design (Transistor Circuit)

NOTE

Transistor circuit solution is not suitable for applications with high baud rates exceeding 460 kbps.

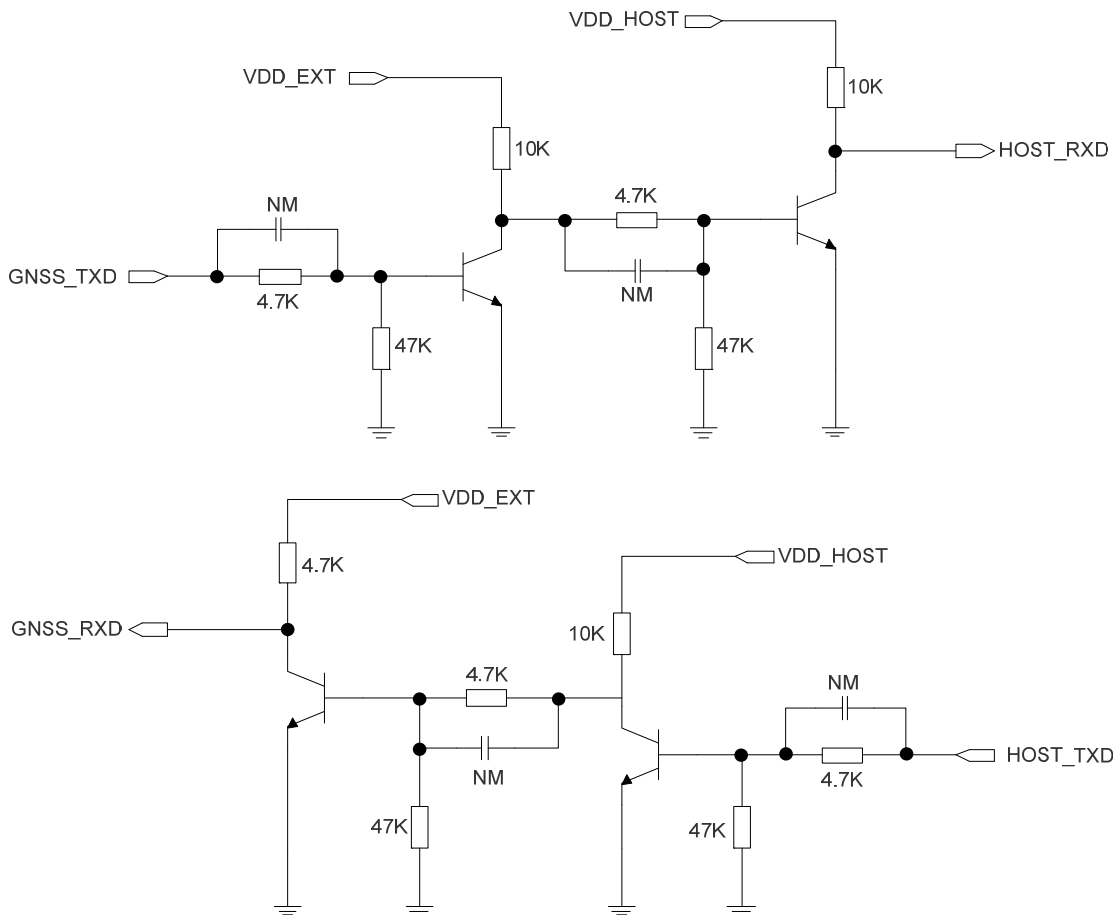

Figure 19: Reference Circuit with Dual-Transistor Circuit (Recommended for GNSS UART)

NOTE

GNSS_TXD is a BOOT_CONFIG pin (pin 27), therefore voltage-level translation IC solution with pull-up circuit or signal transistor/MOSFET circuit is not applicable to it. The dual-transistor circuit solution is recommended for GNSS UART.

3.12. PCM and I2C Interfaces*

BG95 provides one Pulse Code Modulation (PCM) digital interface and one I2C interface which are used for VoLTE or GSM CS voice only.

The following table shows the pin definition of the two interfaces which can be applied on audio codec design.

Table 17: Pin Definition of PCM and I2C Interfaces

Pin Name	Pin No.	I/O	Description	Comment
PCM_CLK	4	DO	PCM clock	1.8 V power domain.
PCM_SYNC	5	DO	PCM data frame sync	1.8 V power domain.
PCM_DIN	6	DI	PCM data input	1.8 V power domain.
PCM_DOUT	7	DO	PCM data output	1.8 V power domain.
I2C_SCL	40	OD	I2C serial clock (for external codec)	Require external pull-up to 1.8 V.
I2C_SDA	41	OD	I2C serial data (for external codec)	Require external pull-up to 1.8 V.

The following figure shows a reference design of PCM and I2C interfaces with an external codec IC.

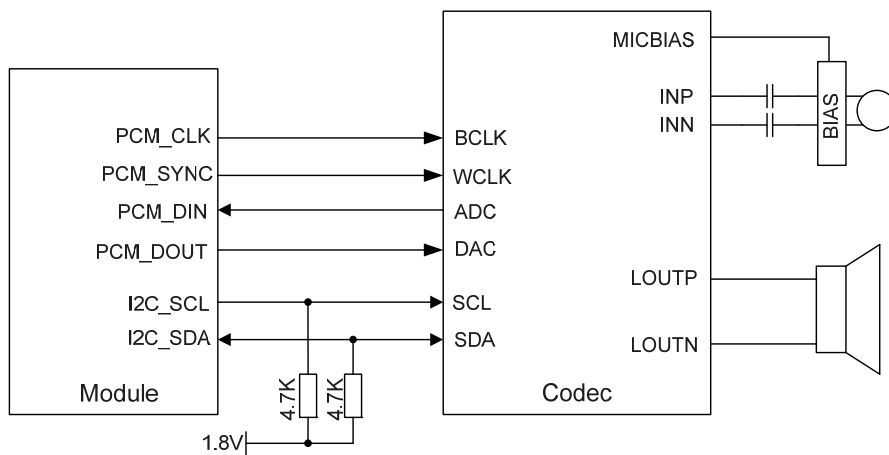

Figure 20: Reference Circuit of PCM Application with Audio Codec

NOTES

1. “*” means under development.
2. PCM and I2C interfaces support VoLTE or GSM CS voice only.

3.13. Network Status Indication

BG95 provides one network status indication pin: NET_STATUS. The pin is used to drive a network status indication LED. The following tables describe the pin definition and logic level changes of NET_STATUS in different network activity status.

Table 18: Pin Definition of NET_STATUS

Pin Name	Pin No.	I/O	Description	Comment
NET_STATUS	21	DO	Module network activity status indication	1.8 V power domain

Table 19: Working State of NET_STATUS

Pin Name	Logic Level Changes	Network Status
NET_STATUS	Flicker slowly (200 ms High/1800 ms Low)	Network searching
	Flicker slowly (1800 ms High/200 ms Low)	Idle
	Flicker quickly (125 ms High/125 ms Low)	Data transfer is ongoing
	Always high	Voice calling

A reference circuit is shown in the following figure.

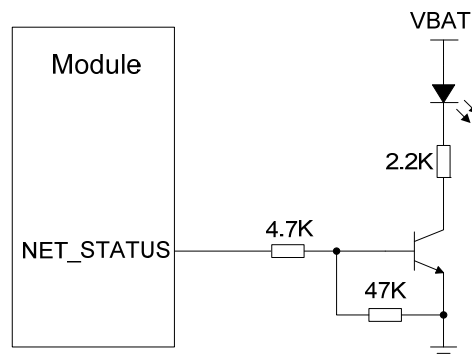

Figure 21: Reference Circuit of the Network Status Indicator

3.14. STATUS

The STATUS pin is used to indicate the operation status of the module. It outputs high level when the module is powered on.

The following table describes the pin definition of STATUS.

Table 20: Pin Definition of STATUS

Pin Name	Pin No.	I/O	Description	Comment
STATUS	20	DO	Module operation status indication	1.8 V power domain

The following figure shows a reference circuit of STATUS.

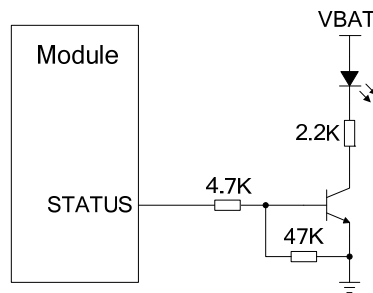

Figure 22: Reference Design of STATUS

3.15. Behaviors of MAIN_RI

`AT+QCFG="risignaltpe","physical"` command can be used to configure MAIN_RI pin behavior.

No matter on which port the URC is presented, the URC will trigger the behavior of MAIN_RI pin. The default behaviors of MAIN_RI pin are shown as below.

Table 21: Default Behaviors of MAIN_RI Pin

State	Response
Idle	MAIN_RI keeps in high level.
URC	MAIN_RI outputs 120 ms low pulse when a new URC returns.

The default MAIN_RI pin behaviors can be configured flexibly by `AT+QCFG="urc/ri/ring"` command. For more details about `AT+QCFG*`, see [document \[2\]](#).

NOTES

1. URC can be outputted from UART port, USB AT port and USB modem port, through configuration via `AT+QURCCFG` command. The default port is USB AT port.

2. “*” means under development.

3.16. USB_BOOT Interface

BG95 provides a USB_BOOT pin. During development or factory production, USB_BOOT can force the module to boot from USB port for firmware upgrade.

Table 22: Pin Definition of USB_BOOT Interface

Pin Name	Pin No.	I/O	Description	Comment
USB_BOOT	75	DI	Force the module into emergency download mode	1.8 V power domain. Active high. If unused, keep it open.

The following figure shows a reference circuit of USB_BOOT interface.

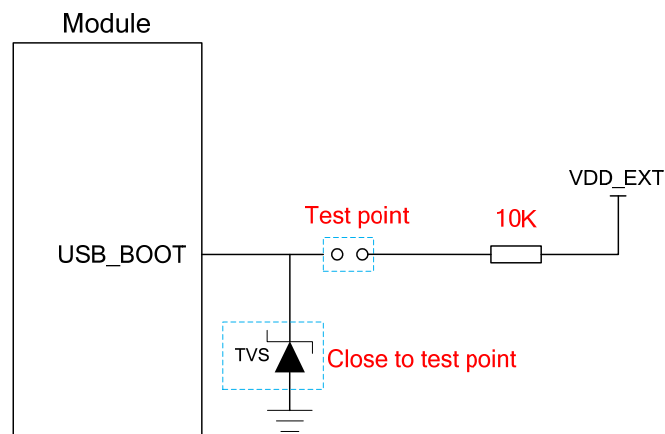

Figure 23: Reference Design of USB_BOOT Interface

The following figure shows the timing of USB_BOOT.

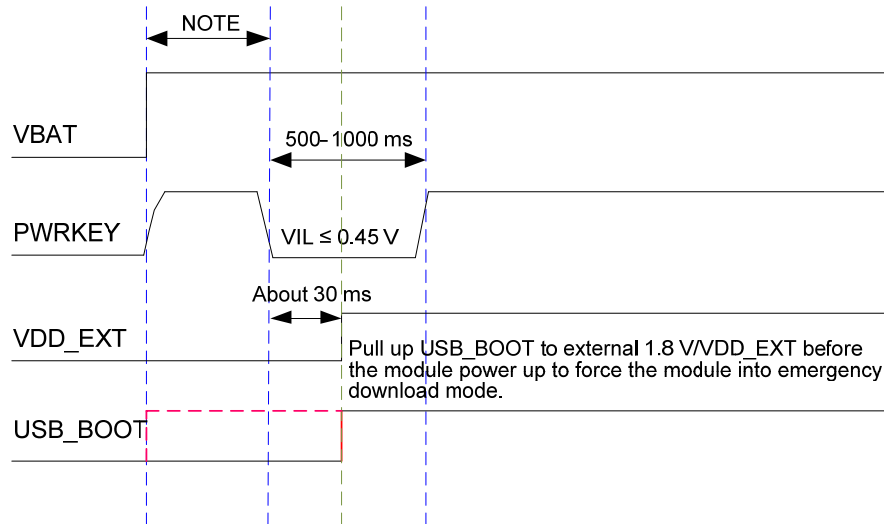

Figure 24: Timing of Turning on Module with USB_BOOT

NOTES

1. It is recommended to reserve the above circuit design during application design.
2. Please make sure that VBAT is stable before pulling down PWRKEY. It is recommended that the time between powering up VBAT and pulling down PWRKEY is no less than 30 ms.
3. When using MCU to control the module entering emergency download mode, please follow the above timing sequence. Connecting the test points as shown in **Figure 23** can manually force the module to enter download mode.

3.17. ADC Interfaces

The module provides two analog-to-digital converter (ADC) interfaces but only one ADC interface can be used at a time. ADC1 connects directly to ADC0 inside the module.

AT+QADC=0 command can be used to read the voltage value on the ADC being used. For more details about the AT command, see **document [2]**.

In order to improve the accuracy of ADC voltage values, the trace of ADC should be ground surrounded.

Table 23: Pin Definition of ADC Interface

Pin Name	Pin No.	I/O	Description	Comment
ADC0	24	AI	General-purpose ADC interface	Do not use ADC0 and ADC1 simultaneously.
ADC1	2	AI	General-purpose ADC interface	

The following table describes the characteristics of ADC interfaces.

Table 24: Characteristics of ADC Interfaces

Parameter	Min.	Typ.	Max.	Unit
Voltage Range	0.1		1.8	V
Resolution (LSB)		64.979		μ V
Analog Bandwidth		500		kHz
Sample Clock		4.8		MHz
Input Resistance	10			M Ω

NOTES

1. ADC input voltage must not exceed 1.8 V.
2. It is prohibited to supply any voltage to ADC pin when VBAT is removed.
3. It is recommended to use resistor divider circuit for ADC application, and the divider resistor accuracy should be no less than 1 %.
4. Do not use ADC0 and ADC1 simultaneously, as ADC1 connects directly to ADC0 inside the module.

3.18. GPIO Interfaces

The module provides nine general-purpose input and output (GPIO) interfaces. **AT+QCFG="gpio"** command can be used to configure the status of GPIO pins. For more details about the AT command, see [document \[2\]](#).

Table 25: Pin Definition of GPIO Interfaces

Pin Name	Pin No.	Description
GPIO1	25	General-purpose input/output
GPIO2	26	General-purpose input/output
GPIO3 ¹⁾	64	General-purpose input/output
GPIO4 ¹⁾	65	General-purpose input/output
GPIO5	66	General-purpose input/output
GPIO6	85	General-purpose input/output
GPIO7	86	General-purpose input/output
GPIO8	87	General-purpose input/output
GPIO9	88	General-purpose input/output

The following table describes the characteristics of GPIO interfaces.

Table 26: Logic Levels of GPIO Interfaces

Parameter	Min.	Max.	Unit
V_{IL}	-0.3	0.6	V
V_{IH}	1.2	2.0	V
V_{OL}	0	0.45	V
V_{OH}	1.35	1.8	V

NOTE

¹⁾ BG95-MF does not support GPIO3 and GPIO4.

3.19. GRFC Interfaces

The module provides two generic RF control interfaces for the control of external antenna tuners.

Table 27: Pin Definition of GRFC Interfaces

Pin Name	Pin No.	Description	Comments
GRFC1	83	Generic RF controller	1.8 V power domain.
GRFC2	84	Generic RF controller	BOOT_CONFIG. Do not pull it up before startup. 1.8 V power domain.

Table 28: Logic Levels of GRFC Interfaces

Parameter	Min.	Max.	Unit
V _{OL}	0	0.45	V
V _{OH}	1.35	1.8	V

Table 29: Truth Table of GRFC Interfaces

GRFC1 Level	GRFC2 Level	Frequency Range (MHz)	Band
Low	Low	880–2200	B1, B2, B3, B4, B8, B25, B66
Low	High	791–894	B5, B18, B19, B20, B26, B27
High	Low	698–803	B12, B13, B28, B85
High	High	617–698	B71

NOTES

- GRFC2 (pin 84) is a BOOT_CONFIG pin. Never pull it up before startup, otherwise the module cannot power on normally.
- BG95-M4 does not support GRFC interfaces.

4 GNSS Receiver

4.1. General Description

BG95 includes a fully integrated global navigation satellite system solution that supports Gen9 VT of Qualcomm (GPS, GLONASS, BeiDou, Galileo and QZSS).

The module supports standard NMEA-0183 protocol, and outputs NMEA sentences at 1 Hz data update rate via USB interface by default.

By default, BG95 GNSS engine is switched off. It has to be switched on via AT command. For more details about GNSS engine technology and configurations, see **document [3]**.

4.2. GNSS Performance

The following table shows the GNSS performance of BG95 series module.

Table 30: GNSS Performance

Parameter	Description	Conditions	Typ.	Unit
Sensitivity (GNSS)	Cold start	Autonomous	-146	dBm
	Reacquisition	Autonomous	-157	dBm
	Tracking	Autonomous	-157	dBm
TTFF (GNSS)	Cold start	Autonomous	35	s
	@ open sky	XTRA enabled	10.4	s
	Warm start	Autonomous	23	s
	@ open sky	XTRA enabled	1.53	s

	Hot start @ open sky	Autonomous	1.6	s
		XTRA enabled	1.5	s
Accuracy (GNSS)	CEP-50	Autonomous @open sky	< 3	m

NOTES

1. Tracking sensitivity: the minimum GNSS signal power at which the module can maintain lock (keep positioning for at least 3 minutes continuously).
2. Reacquisition sensitivity: the minimum GNSS signal power required for the module to maintain lock within 3 minutes after loss of lock.
3. Cold start sensitivity: the minimum GNSS signal power at which the module can fix position successfully within 3 minutes after executing cold start command.

4.3. Layout Guidelines

The following layout guidelines should be taken into account in application designs.

- Maximize the distance between GNSS antenna and main antenna.
- Digital circuits such as (U)SIM card, USB interface, camera module, display connector and SD card should be kept away from the antennas.
- Use ground vias around the GNSS trace and sensitive analog signal traces to provide coplanar isolation and protection.
- Keep 50 Ω characteristic impedance for ANT_GNSS trace.

See **Chapter 5** for GNSS antenna reference design and antenna installation information.

5 Antenna Interfaces

BG95 includes a main antenna interface and a GNSS antenna interface. The antenna ports have an impedance of 50 Ω .

5.1. Main Antenna Interface

5.1.1. Pin Definition

The pin definition of main antenna interface is shown below.

Table 31: Pin Definition of Main Antenna Interface

Pin Name	Pin No.	I/O	Description	Comment
ANT_MAIN	60	IO	Main antenna interface	50 Ω characteristic impedance

5.1.2. Operating Frequency

Table 32: Operating Frequency of BG95 Series Module

3GPP Band	Transmit	Receive	Unit
LTE-FDD B1	1920–1980	2110–2170	MHz
LTE-FDD B2, PCS1900	1850–1910	1930–1990	MHz
LTE-FDD B3, DCS1800	1710–1785	1805–1880	MHz
LTE-FDD B4	1710–1755	2110–2155	MHz
LTE-FDD B5, GSM850	824–849	869–894	MHz
LTE-FDD B8, EGSM900	880–915	925–960	MHz
LTE-FDD B12	699–716	729–746	MHz

LTE-FDD B13	777–787	746–756	MHz
LTE-FDD B18	815–830	860–875	MHz
LTE-FDD B19	830–845	875–890	MHz
LTE-FDD B20	832–862	791–821	MHz
LTE-FDD B25	1850–1915	1930–1995	MHz
LTE-FDD B26 ¹⁾	814–849	859–894	MHz
LTE-FDD B27 ¹⁾	807–824	852–869	MHz
LTE-FDD B28	703–748	758–803	MHz
LTE-FDD B31 ³⁾	452.5–457.5	462.5–467.5	MHz
LTE-FDD B66	1710–1780	2110–2180	MHz
LTE-FDD B71 ²⁾	663–698	617–652	MHz
LTE-FDD B72 ³⁾	451–456	461–466	MHz
LTE-FDD B73 ³⁾	450–455	460–465	MHz
LTE-FDD B85	698–716	728–746	MHz

NOTES

- ¹⁾ LTE-FDD B26 and B27 are supported by Cat M1 only.
- ²⁾ LTE-FDD B71 is supported by Cat NB2 only.
- ³⁾ LTE-FDD B31, B72 and B73 are supported by BG95-M4 only.

5.1.3. Reference Design of Main Antenna Interface

A reference design of main antenna interface is shown as below. It is recommended to reserve a π -type matching circuit for better RF performance, and the π -type matching components (R1/C1/C2) should be placed as close to the antenna as possible. The capacitors are not mounted by default.

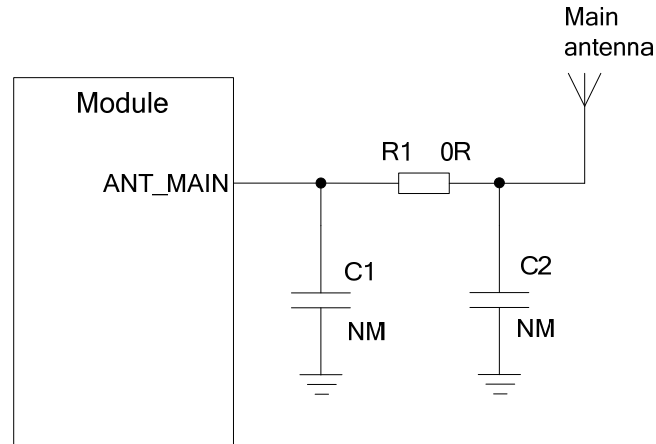

Figure 25: Reference Design of Main Antenna Interface

5.1.4. Reference Design of RF Layout

For users' PCB, the characteristic impedance of all RF traces should be controlled to 50 Ω . The impedance of the RF traces is usually determined by the trace width (W), the materials' dielectric constant, height from the reference ground to the signal layer (H), and the clearance between RF traces and grounds (S). Microstrip or coplanar waveguide is typically used in RF layout to control characteristic impedance. The following are reference designs of microstrip or coplanar waveguide with different PCB structures.

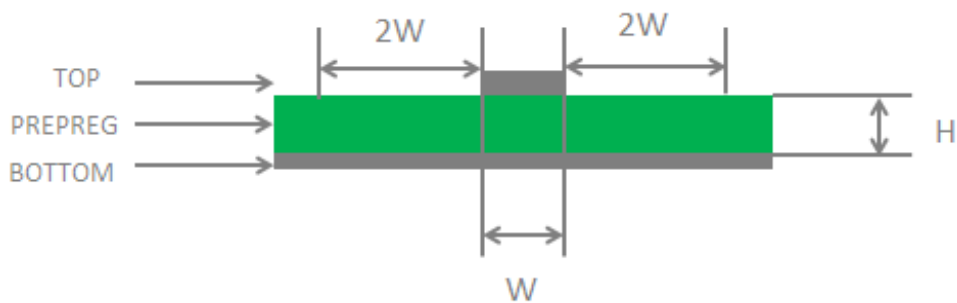

Figure 26: Microstrip Design on a 2-layer PCB

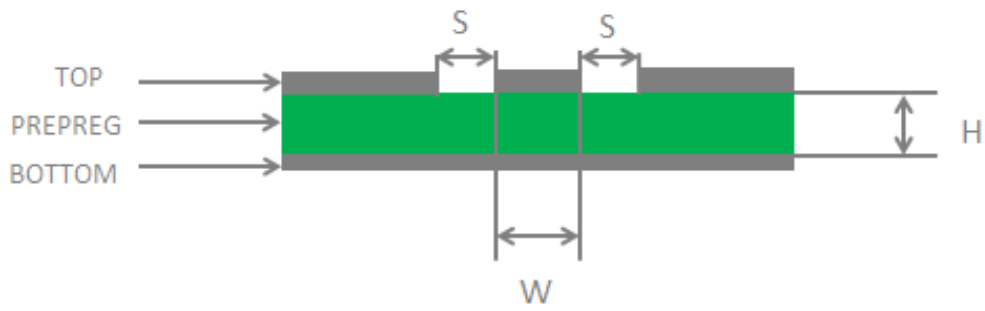

Figure 27: Coplanar Waveguide Design on a 2-layer PCB

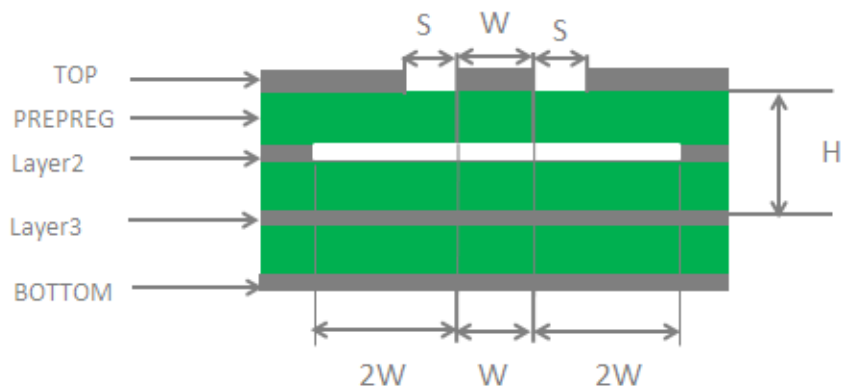

Figure 28: Coplanar Waveguide Design on a 4-layer PCB (Layer 3 as Reference Ground)

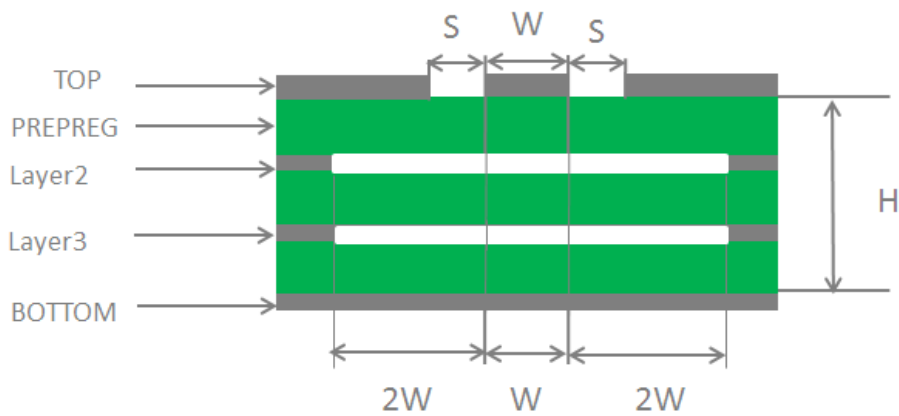

Figure 29: Coplanar Waveguide Design on a 4-layer PCB (Layer 4 as Reference Ground)

In order to ensure RF performance and reliability, the following principles should be complied with in RF layout design:

- Use an impedance simulation tool to accurately control the characteristic impedance of RF traces to 50 Ω .
- The GND pins adjacent to RF pins should not be designed as thermal relief pads, and should be fully connected to ground.
- The distance between the RF pins and the RF connector should be as short as possible, and all the right-angle traces should be changed to curved ones.
- There should be clearance under the signal pin of the antenna connector or solder joint.
- The reference ground of RF traces should be complete. Meanwhile, adding some ground vias around RF traces and the reference ground could help to improve RF performance. The distance between the ground vias and RF traces should be no less than two times as wide as RF signal traces ($2 \times W$).
- Keep RF traces away from interference sources, and avoid intersection and paralleling between traces on adjacent layers.

For more details about RF layout, see **document [4]**.

5.2. GNSS Antenna Interface

The following tables show the pin definition and frequency specification of GNSS antenna interface.

Table 33: Pin Definition of GNSS Antenna Interface

Pin Name	Pin No.	I/O	Description	Comment
ANT_GNSS	49	AI	GNSS antenna interface	50 Ω impedance

Table 34: GNSS Frequency

Type	Frequency	Unit
GPS	1575.42 \pm 1.023	MHz
GLONASS	1597.5–1605.8	MHz
Galileo	1575.42 \pm 2.046	MHz
BeiDou	1561.098 \pm 2.046	MHz
QZSS	1575.42 \pm 1.023	MHz

A reference design of GNSS antenna interface is shown as below.

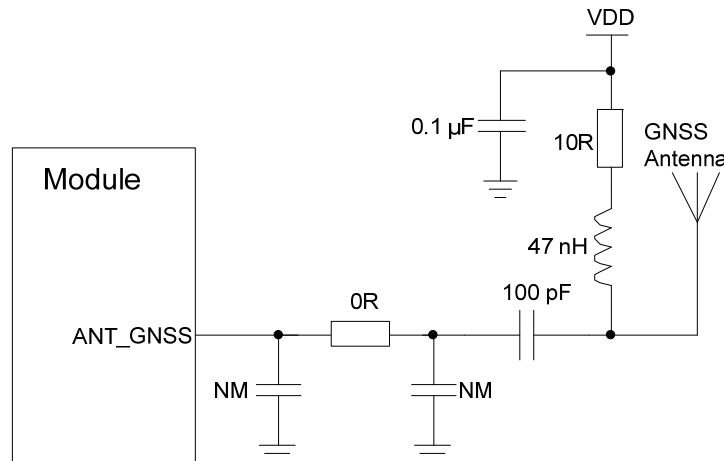

Figure 30: Reference Circuit of GNSS Antenna Interface

NOTES

1. An external LDO can be selected to supply power according to the active antenna requirement.
2. If the module is designed with a passive antenna, then the VDD circuit is not needed.

5.3. Wi-Fi Antenna Interface*

BG95-MF supports Wi-Fi antenna interface through which the module realizes Wi-Fi positioning (receiving only).

The following tables show the pin definition of Wi-Fi antenna interface.

Table 35: Pin Definition of Wi-Fi Antenna Interface

Pin Name	Pin No.	I/O	Description	Comment
ANT_WIFI	56	AI	Wi-Fi antenna interface	50 Ω impedance

NOTE

“*” means under development.

5.4. Antenna Installation

5.4.1. Antenna Requirements

The following table shows the requirements on main antenna and GNSS antenna.

Table 36: Antenna Requirements

Antenna Type	Requirements
GNSS ¹⁾	Frequency range: 1559–1609 MHz Polarization: RHCP or linear VSWR: < 2 (Typ.) Passive antenna gain: > 0 dBi Active antenna noise figure: < 1.5 dB Active antenna gain: > 0 dBi Active antenna embedded LNA gain: < 17 dB
LTE/GSM	VSWR: ≤ 2 Efficiency: > 30 % Max Input Power: 50 W Input Impedance: 50 Ω Cable Insertion Loss: < 1 dB (LTE B5/B8/B12/B13/B14/B18/B19/B20/B26/B27/B28/B71/B85, GSM850/EGSM900 Cable Insertion Loss: < 1.5 dB (LTE B1/B2/B3/B4/B25/B66, DCS1800/PCS1900)

5.4.2. Recommended RF Connector for Antenna Installation

If RF connector is used for antenna connection, it is recommended to use U.FL-R-SMT connectors provided by *HIROSE*.

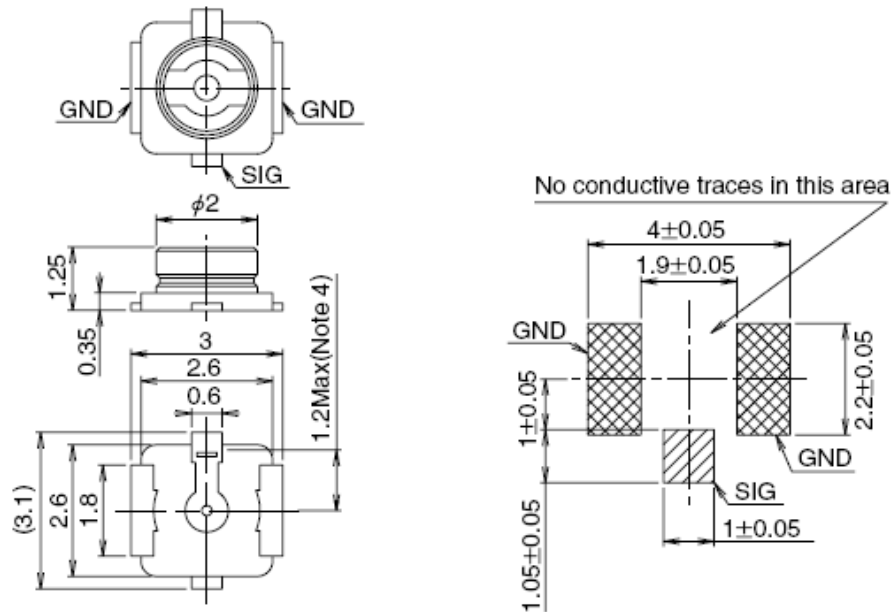

Figure 31: Dimensions of the U.FL-R-SMT Connector (Unit: mm)

U.FL-LP serial connectors listed in the following figure can be used to match the U.FL-R-SMT.

	U.FL-LP-040	U.FL-LP-066	U.FL-LP(V)-040	U.FL-LP-062	U.FL-LP-088
Part No.					
Mated Height	2.5mm Max. (2.4mm Nom.)	2.5mm Max. (2.4mm Nom.)	2.0mm Max. (1.9mm Nom.)	2.4mm Max. (2.3mm Nom.)	2.4mm Max. (2.3mm Nom.)
Applicable cable	Dia. 0.81mm Coaxial cable	Dia. 1.13mm and Dia. 1.32mm Coaxial cable	Dia. 0.81mm Coaxial cable	Dia. 1mm Coaxial cable	Dia. 1.37mm Coaxial cable
Weight (mg)	53.7	59.1	34.8	45.5	71.7
RoHS	YES				

Figure 32: Mechanicals of U.FL-LP Connectors

The following figure describes the space factor of mated connector.

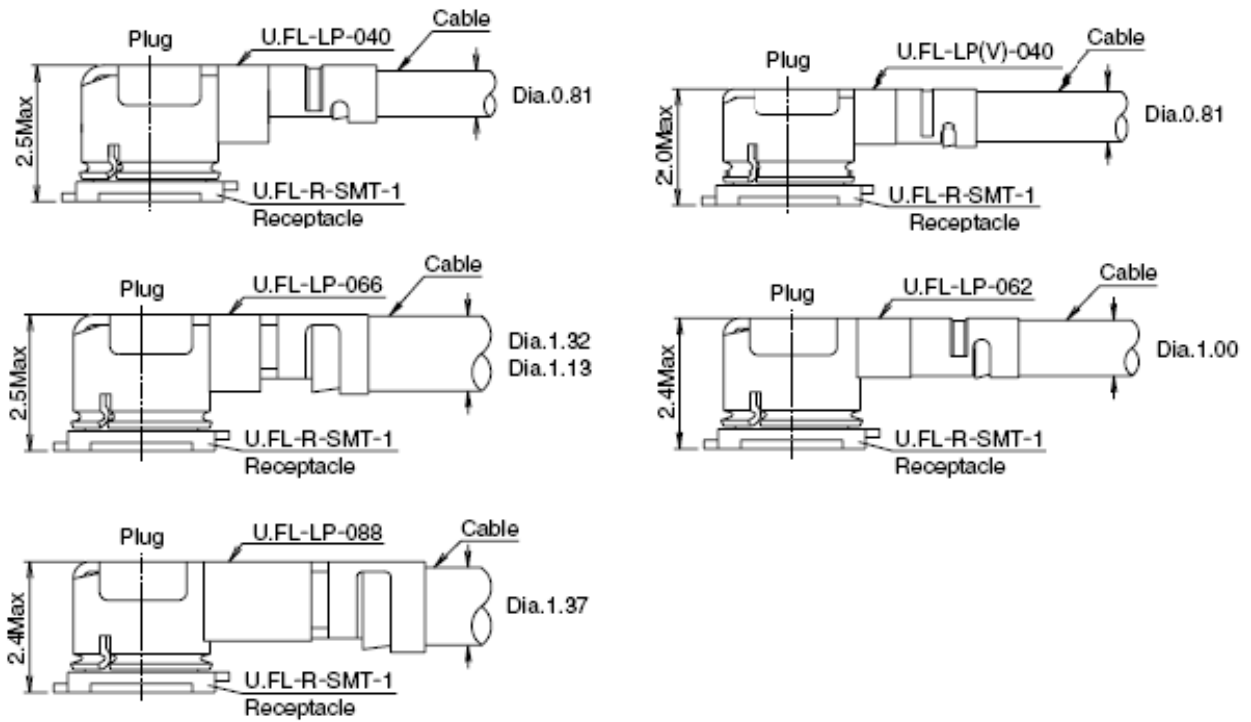

Figure 33: Space Factor of Mated Connector (Unit: mm)

For more details, please visit <http://www.hirose.com/>.

6 Electrical, Reliability and Radio Characteristics

6.1. Absolute Maximum Ratings

Absolute maximum ratings for power supply and voltage on digital and analog pins of the module are listed in the following table.

Table 37: Absolute Maximum Ratings

Parameter	Min.	Max.	Unit
VBAT_BB	-0.5	6.0	V
VBAT_RF	-0.3	6.0	V
USB_VBUS	-0.3	5.5	V
Voltage at Digital Pins	-0.3	2.09	V

6.2. Power Supply Ratings

Table 38: Power Supply Ratings

Parameter	Description	Conditions	Module	Min.	Typ.	Max.	Unit
VBAT	VBAT_BB/ VBAT_RF	The actual input voltages must be kept between the minimum and the maximum values.	BG95-M1/ BG95-M2/ BG95-N1	2.6	3.3	4.8	V
			BG95-M3/ BG95-M5/ BG95-M6	3.3	3.8	4.3	V

			BG95-M4	3.2	3.8	4.2	V
			BG95-MF	TBD	3.8	TBD	V
I_{VBAT}	Peak supply current (during transmission slot)	Maximum power control level on EGSM900	BG95-M3/ BG95-M5		1.8	2.0	A
USB_VBUS	USB detection		BG95 series		5.0		V

6.3. Operating and Storage Temperatures

The operating and storage temperatures of the module are listed in the following table.

Table 39: Operating and Storage Temperatures

Parameter	Min.	Typ.	Max.	Unit
Operation Temperature Range ¹⁾	-35	+25	+75	°C
Extended Temperature Range ²⁾	-40		+85	°C
Storage Temperature Range	-40		+90	°C

NOTES

- ¹⁾ Within operating temperature range, the module meets 3GPP specifications.
- ²⁾ Within extended temperature range, the module remains the ability to establish and maintain functions such as SMS and data transmission, without any unrecoverable malfunction. Radio spectrum and radio network are not influenced, while one or more specifications, such as P_{out} , may exceed the specified tolerances of 3GPP. When the temperature returns to the normal operating temperature levels, the module meets 3GPP specifications again.

6.4. Current Consumption

The following table shows current consumption of BG95 series module.

Table 40: BG95-M1 Current Consumption (3.3 V Power Supply, Room Temperature)

Description	Conditions	Average	Max.	Unit
Leakage ¹⁾	Power-off @ USB and UART disconnected	14	-	μA
PSM ²⁾	Power Saving Mode	4	-	μA
Rock Bottom	AT+CFUN=0 @ Sleep mode	0.53	-	mA
Sleep Mode (USB disconnected)	LTE Cat M1 DRX = 1.28 s	1.7	-	mA
	LTE Cat M1 e-I-DRX = 81.92 s @ PTW = 2.56 s, DRX = 1.28 s	0.577	-	mA
Idle Mode (USB disconnected)	LTE Cat M1 DRX = 1.28 s	20	-	mA
	LTE Cat M1 e-I-DRX = 81.92 s @ PTW = 2.56 s, DRX = 1.28 s	19.57	-	mA
LTE Cat M1 data transfer (GNSS OFF)	Band 1 @ 21.04 dBm	201	438	mA
	Band 2 @ 20.67 dBm	200	435	mA
	Band 3 @ 21.05 dBm	196	418	mA
	Band 4 @ 20.8 dBm	193	405	mA
	Band 5 @ 21.06 dBm	215	487	mA
	Band 8 @ 20.89 dBm	210	464	mA
	Band 12 @ 20.96 dBm	205	448	mA
	Band 13 @ 20.57 dBm	216	489	mA
	Band 18 @ 21.14 dBm	217	481	mA
	Band 19 @ 21.2 dBm	206	455	mA
	Band 20 @ 21 dBm	218	490	mA
	Band 25 @ 20.86 dBm	201	437	mA
	Band 26 @ 21.1 dBm	221	490	mA
	Band 27 @ 21.05 dBm	212	479	mA
Band 28A @ 20.87 dBm	211	469	mA	
Band 28B @ 20.91 dBm	214	474	mA	

Band 66 @ 20.65 dBm	193	418	mA
Band 85 @ 21.01 dBm	208	458	mA

Table 41: BG95-M2 Current Consumption (3.3 V Power Supply, Room Temperature)

Description	Conditions	Average	Max.	Unit
Leakage ¹⁾	Power-off @ USB and UART disconnected	14	-	μA
PSM ²⁾	Power Saving Mode	3.9	-	μA
Rock Bottom	AT+CFUN=0 @ Sleep mode	0.51	-	mA
Sleep Mode (USB disconnected)	LTE Cat M1 DRX = 1.28 s	1.7	-	mA
	LTE Cat NB1 DRX = 1.28 s	1.6	-	mA
	LTE Cat M1 e-I-DRX = 81.92 s @ PTW = 2.56 s, DRX = 1.28 s	0.549	-	mA
	LTE Cat NB1 e-I-DRX = 81.92 s @ PTW = 2.56 s, DRX = 1.28 s	0.592	-	mA
	LTE Cat M1 DRX = 1.28 s	21.2	-	mA
	LTE Cat NB1 DRX = 1.28 s	16.8	-	mA
Idle Mode (USB disconnected)	LTE Cat M1 e-I-DRX = 81.92 s @ PTW = 2.56 s, DRX = 1.28 s	20.6	-	mA
	LTE Cat NB1 e-I-DRX = 81.92 s @ PTW = 2.56 s, DRX = 1.28 s	16.4	-	mA
	Band 1 @ 21.17 dBm	201	452	mA
	Band 2 @ 21.03 dBm	202	434	mA
LTE Cat M1 data transfer (GNSS OFF)	Band 3 @ 20.93 dBm	191	415	mA
	Band 4 @ 21.01 dBm	193	425	mA
	Band 5 @ 21.18 dBm	218	504	mA
	Band 8 @ 21.16 dBm	211	480	mA
	Band 12 @ 21.07 dBm	205	457	mA

	Band 13 @ 21.31 dBm	227	533	mA
	Band 18 @ 21.09 dBm	216	498	mA
	Band 19 @ 21.21 dBm	219	508	mA
	Band 20 @ 21.21 dBm	218	501	mA
	Band 25 @ 21.1 dBm	202	455	mA
	Band 26 @ 21.28 dBm	219	508	mA
	Band 27 @ 21.08 dBm	217	502	mA
	Band 28A @ 21.27 dBm	213	477	mA
	Band 28B @ 21.05 dBm	215	497	mA
	Band 66 @ 20.76 dBm	190	407	mA
	Band 85 @ 21.06 dBm	205	457	mA
	Band 1 @ 21.38 dBm	163	410	mA
	Band 2 @ 21.32 dBm	160	403	mA
	Band 3 @ 21.16 dBm	150	365	mA
	Band 4 @ 21.18 dBm	149	376	mA
	Band 5 @ 20.92 dBm	174	447	mA
	Band 8 @ 21.7 dBm	170	438	mA
	Band 12 @ 21.1 dBm	160	403	mA
LTE Cat NB1 data transfer (GNSS OFF)	Band 13 @ 21.11 dBm	185	484	mA
	Band 18 @ 20.85 dBm	174	451	mA
	Band 19 @ 21.18 dBm	177	462	mA
	Band 20 @ 21.19 dBm	178	457	mA
	Band 25 @ 21.2 dBm	158	404	mA
	Band 28 @ 20.56 dBm	164	421	mA
	Band 66 @ 21.26 dBm	151	380	mA
	Band 71 @ 21.44 dBm	162	412	mA
	Band 85 @ 21.82 dBm	164	419	mA

Table 42: BG95-M3 Current Consumption (3.8 V Power Supply, Room Temperature)

Description	Conditions	Average	Max.	Unit
Leakage ¹⁾	Power-off @ USB and UART disconnected	14.5	-	μA
PSM ²⁾	Power Saving Mode	3.9	-	μA
Rock Bottom	AT+CFUN=0 @ Sleep mode	0.575	-	mA
	LTE Cat M1 DRX = 1.28 s	1.65	-	mA
	LTE Cat NB1 DRX = 1.28 s	1.56	-	mA
Sleep Mode (USB disconnected)	LTE Cat M1 e-I-DRX = 81.92 s @ PTW = 2.56 s, DRX = 1.28 s	0.63	-	mA
	LTE Cat NB1 e-I-DRX = 81.92 s @ PTW = 2.56 s, DRX = 1.28 s	0.67	-	mA
Idle Mode (USB disconnected)	LTE Cat M1 DRX = 1.28 s	18.9	-	mA
	LTE Cat NB1 DRX = 1.28 s	14.8	-	mA
Idle Mode (USB disconnected)	LTE Cat M1 e-I-DRX = 81.92 s @ PTW = 2.56 s, DRX = 1.28 s	18.2	-	mA
	LTE Cat NB1 e-I-DRX = 81.92 s @ PTW = 2.56 s, DRX = 1.28 s	14.3	-	mA
LTE Cat M1 data transfer (GNSS OFF)	Band 1 @ 21.03 dBm	186	412	mA
	Band 2 @ 21.13 dBm	187	402	mA
	Band 3 @ 21.42 dBm	184	403	mA
	Band 4 @ 21.27 dBm	182	387	mA
	Band 5 @ 21.22 dBm	192	422	mA
	Band 8 @ 21.11 dBm	190	413	mA
	Band 12 @ 20.98 dBm	185	412	mA
	Band 13 @ 21.05 dBm	199	450	mA
	Band 18 @ 21.05 dBm	193	434	mA
	Band 19 @ 20.9 dBm	191	430	mA

	Band 20 @ 20.94 dBm	192	429	mA
	Band 25 @ 20.09 dBm	186	416	mA
	Band 26 @ 21.19 dBm	193	436	mA
	Band 27 @ 21.12 dBm	193	437	mA
	Band 28A @ 20.99 dBm	188	431	mA
	Band 28B @ 20.97 dBm	190	425	mA
	Band 66 @ 20.95 dBm	181	382	mA
	Band 85 @ 21.06 dBm	185	405	mA
	Band 1 @ 21.19 dBm	149	373	mA
	Band 2 @ 21.43 dBm	151	384	mA
	Band 3 @ 21.4 dBm	144	360	mA
	Band 4 @ 21.48 dBm	145	364	mA
	Band 5 @ 21.54 dBm	165	423	mA
	Band 8 @ 21.13 dBm	155	399	mA
	Band 12 @ 21.43 dBm	150	385	mA
LTE Cat NB1 data transfer (GNSS OFF)	Band 13 @ 21.62 dBm	172	442	mA
	Band 18 @ 21.5 dBm	164	427	mA
	Band 19 @ 21.48 dBm	164	431	mA
	Band 20 @ 21.55 dBm	165	423	mA
	Band 25 @ 21.61 dBm	153	389	mA
	Band 28 @ 21.45 dBm	158	410	mA
	Band 66 @ 21.5 dBm	145	376	mA
	Band 71 @ 20.71 dBm	132	329	mA
	Band 85 @ 21.82 dBm	154	395	mA
	GPRS data transfer (GNSS OFF)	GPRS GSM850 4UL/1DL @ 28 dBm	518	1165
GPRS GSM900 4UL/1DL @ 28 dBm		524	1189	mA
GPRS DCS1800 4UL/1DL @ 25 dBm		327	782	mA

	GPRS PCS1900 4UL/1DL @ 25 dBm	382	809	mA
	EDGE GSM850 4UL/1DL @ 23 dBm	523	1076	mA
EDGE data transfer (GNSS OFF)	EDGE GSM900 4UL/1DL @ 21 dBm	496	1084	mA
	EDGE DCS1800 4UL/1DL @ 21 dBm	432	908	mA
	EDGE PCS1900 4UL/1DL @ 21 dBm	421	868	mA

Table 43: BG95-M5 Current Consumption (3.8 V Power Supply, Room Temperature)

Description	Conditions	Average	Max.	Unit
Leakage ¹⁾	Power-off @ USB and UART disconnected	15	-	μA
PSM ²⁾	Power Saving Mode	6	-	μA
Rock Bottom	AT+CFUN=0 @ Sleep mode	0.633	-	mA
Sleep Mode (USB disconnected)	LTE Cat M1 DRX = 1.28 sDRX = 1.28 s	1.7	-	mA
	LTE Cat NB1 DRX = 1.28 s	1.67	-	mA
	LTE Cat M1 e-I-DRX = 81.92 s @ PTW = 2.56 s, DRX = 1.28 s	0.72	-	mA
	LTE Cat NB1 e-I-DRX = 81.92 s @ PTW = 2.56 s, DRX = 1.28 s	0.68	-	mA
Idle Mode (USB disconnected)	LTE Cat M1 DRX = 1.28 sDRX = 1.28 s	17.3	-	mA
	LTE Cat NB1 DRX = 1.28 s	13.5	-	mA
	LTE Cat M1 e-I-DRX = 81.92 s @ PTW = 2.56 s, DRX = 1.28 s	16.6	-	mA
	LTE Cat NB1 e-I-DRX = 81.92 s @ PTW = 2.56 s, DRX = 1.28 s	13.1	-	mA
LTE Cat M1 data transfer (GNSS OFF)	Band 1 @ 23.17 dBm	227	554	mA
	Band 2 @ 22.77 dBm	220	532	mA
	Band 3 @ 22.92dBm	229	557	mA
	Band 4 @ 22.89 dBm	228	553	mA

	Band 5 @ 23.49 dBm	231	563	mA
	Band 8 @ 22.99dBm	226	545	mA
	Band 12 @ 22.95 dBm	210	494	mA
	Band 13 @ 22.81 dBm	220	523	mA
	Band 18 @ 22.42 dBm	218	518	mA
	Band 19 @ 23.23 dBm	227	550	mA
	Band 20 @ 22.31 dBm	220	521	mA
	Band 25 @ 22.97 dBm	223	534	mA
	Band 26 @ 23.12 dBm	227	549	mA
	Band 27 @ 23.18 dBm	225	547	mA
	Band 28A @ 23.09 dBm	214	508	mA
	Band 28B @ 22.88 dBm	215	509	mA
	Band 66 @ 22.71 dBm	228	553	mA
	Band 85 @ 22.75 dBm	204	473	mA
LTE Cat NB1 data transfer (GNSS OFF)	Band 1 @ 22.83 dBm	185	493	mA
	Band 2 @ 23.38 dBm	189	504	mA
	Band 3 @ 23.53 dBm	203	546	mA
	Band 4 @ 23.52 dBm	207	561	mA
	Band 5 @ 23.86 dBm	210	573	mA
	Band 8 @ 23.74 dBm	208	563	mA
	Band 12 @ 23.62 dBm	189	510	mA
	Band 13 @ 23.81 dBm	203	549	mA
	Band 18 @ 23.68 dBm	204	555	mA
	Band 19 @ 23.45 dBm	200	540	mA
	Band 20 @ 23.7 dBm	208	565	mA
	Band 25 @ 22.8 dBm	187	495	mA
	Band 28 @ 23.77 dBm	188	505	mA

	Band 66 @ 23.51 dBm	203	554	mA
	Band 71 @ 23.62 dBm	185	493	mA
	Band 85 @ 22.51 dBm	172	460	mA
GPRS data transfer (GNSS OFF)	GPRS GSM850 4UL/1DL @ 28 dBm	628	1336	mA
	GPRS GSM900 4UL/1DL @ 28 dBm	535	1114	mA
	GPRS DCS1800 4UL/1DL @ 26dBm	389	796	mA
	GPRS PCS1900 4UL/1DL @ 26dBm	407	814	mA
EDGE data transfer (GNSS OFF)	EDGE GSM850 4UL/1DL @ 23 dBm	531	1101	mA
	EDGE GSM900 4UL/1DL @ 22dBm	534	1086	mA
	EDGE DCS1800 4UL/1DL @ 22dBm	441	901	mA
	EDGE PCS1900 4UL/1DL @ 22 dBm	442	887	mA

Table 44: BG95-M6 Current Consumption (3.8 V Power Supply, Room Temperature)

Description	Conditions	Average	Max.	Unit
Leakage ¹⁾	Power-off @ USB and UART disconnected	15	-	μA
PSM ²⁾	Power Saving Mode	5	-	μA
Rock Bottom	AT+CFUN=0 @ Sleep mode	0.5	-	mA
Sleep Mode (USB disconnected)	LTE Cat M1 DRX = 1.28 s	1.5	-	mA
	LTE Cat NB1 DRX = 1.28 s	1.41	-	mA
	LTE Cat M1 e-I-DRX = 81.92 s @ PTW = 2.56 s, DRX = 1.28 s	0.58	-	mA
	LTE Cat NB1 e-I-DRX = 81.92 s @ PTW = 2.56 s, DRX = 1.28 s	0.55	-	mA
Idle Mode (USB disconnected)	LTE Cat M1 DRX = 1.28 s	18.5	-	mA
	LTE Cat NB1 DRX = 1.28 s	14.2	-	mA
	LTE Cat M1 e-I-DRX = 81.92 s @ PTW = 2.56 s, DRX = 1.28 s	18.2	-	mA

	LTE Cat NB1 e-I-DRX = 81.92 s @ PTW = 2.56 s, DRX = 1.28 s	14	-	mA
	Band 1 @ 23.03 dBm	207	491	mA
	Band 2 @ 22.91 dBm	203	473	mA
	Band 3 @ 23.2dBm	211	499	mA
	Band 4 @ 23.18 dBm	211	500	mA
	Band 5 @ 23.02 dBm	213	505	mA
	Band 8 @ 23.47 dBm	231	563	mA
	Band 12 @ 23.08 dBm	195	444	mA
	Band 13 @ 23.04 dBm	204	473	mA
LTE Cat M1 data transfer (GNSS OFF)	Band 18 @ 23.22 dBm	212	501	mA
	Band 19 @ 23.14 dBm	215	530	mA
	Band 20 @ 22.31 dBm	220	530	mA
	Band 25 @ 23.06 dBm	209	494	mA
	Band 26 @ 23.19 dBm	215	509	mA
	Band 27 @ 22.99 dBm	208	490	mA
	Band 28A @ 23.43 dBm	200	461	mA
	Band 28B @ 22.41 dBm	202	467	mA
	Band 66 @ 23.18 dBm	207	485	mA
	Band 85 @ 23.07 dBm	196	448	mA
	Band 1 @ 23.15 dBm	170	451	mA
	Band 2 @ 23.11 dBm	167	433	mA
	Band 3 @ 23.13 dBm	180	478	mA
LTE Cat NB1 data transfer (GNSS OFF)	Band 4 @ 23.12 dBm	178	470	mA
	Band 5 @ 23.11 dBm	182	482	mA
	Band 8 @ 23.11 dBm	194	521	mA
	Band 12 @ 23.32 dBm	163	424	mA

Band 13 @ 23.06 dBm	169	443	mA
Band 18 @ 23.32 dBm	184	486	mA
Band 19 @ 23.26 dBm	188	493	mA
Band 20 @ 23.31 dBm	183	480	mA
Band 25 @ 23.27 dBm	171	458	mA
Band 28 @ 23.6 dBm	167	432	mA
Band 66 @ 23.12 dBm	179	474	mA
Band 71 @ 23.11 dBm	157	412	mA
Band 85 @ 23.13 dBm	160	409	mA

NOTES

- ¹⁾ The current consumption of BG95 series module in PSM is much lower than that in power off mode, and this is because of the following two designs:
 - More internal power supplies are powered off in PSM.
 - Also the internal clock frequency is reduced in PSM.
- ²⁾ The module's USB and UART are disconnected and GSM network (if available) does not support PSM.

Table 45: GNSS Current Consumption of BG95-M1/-M2 (3.3 V Power Supply, Room Temperature)

Description	Conditions	Typ.	Unit
Searching (AT+CFUN=0)	Cold start @ Instrument	80	mA
	Host start @ Instrument	77	mA
	Warm start @ Instrument	TBD	mA
	Lost start @ Instrument	79	mA
Tracking (AT+CFUN=0)	Instrument Environment @ Passive Antenna	63	mA
	Half Sky @ Real network, Passive Antenna	TBD	mA
	Half Sky @ Real network, Active Antenna	TBD	mA

Table 46: GNSS Current Consumption of BG95-M3 (3.8 V Power Supply, Room Temperature)

Description	Conditions	Typ.	Unit
Searching (AT+CFUN=0)	Cold start @ Instrument	70	mA
	Host start @ Instrument	71	mA
	Warm start @ Instrument	71	mA
	Lost start @ Instrument	69	mA
Tracking (AT+CFUN=0)	Instrument Environment @ Passive Antenna	55	mA
	Half Sky @ Real network, Passive Antenna	TBD	mA
	Half Sky @ Real network, Active Antenna	TBD	mA

Table 47: GNSS Current Consumption of BG95-M5/-M6 (3.8 V Power Supply, Room Temperature)

Description	Conditions	Typ.	Unit
Searching (AT+CFUN=0)	Cold start @ Instrument	68	mA
	Host start @ Instrument	67	mA
	Warm start @ Instrument	TBD	mA
	Lost start @ Instrument	69	mA
Tracking (AT+CFUN=0)	Instrument Environment @ Passive Antenna	53	mA
	Half Sky @ Real network, Passive Antenna	TBD	mA
	Half Sky @ Real network, Active Antenna	TBD	mA

6.5. RF Output Power

The following table shows the RF output power of BG95 series module.

Table 48: Conducted RF Output Power of BG95-M1/-M2/-M3/-N1/-MF

Frequency	Max.	Min.
LTE-FDD B1/B2/B3/B4/B5/B8/B12/B13/B18/B19/B20/ B25/B26 ¹⁾ /B27 ¹⁾ /B28/B66/B71 ²⁾ /B85	21 dBm +1.7/-3 dB	< -39 dBm
GSM850/EGSM900	33 dBm ±2 dB	5 dBm ±5 dB
DCS1800/PCS1900	30 dBm ±2 dB	0 dBm ±5 dB
GSM850/EGSM900 (8-PSK)	27 dBm ±3 dB	5 dBm ±5 dB
DCS1800/PCS1900 (8-PSK)	26 dBm ±3 dB	0 dBm ±5 dB

Table 49: Conducted RF Output Power of BG95-M4

Frequency	Max.	Min.
LTE-FDD B1/B2/B3/B4/B5/B8/B12/B13/B18/B19/B20/ B25/B26 ¹⁾ /B27 ¹⁾ /B28/B66/B85	21 dBm +1.7/-3 dB	< -39 dBm
LTE-FDD B31/B72/B73 ³⁾	23 dBm ±2 dB	< -39 dBm

Table 50: Conducted RF Output Power of BG95-M5/-M6

Frequency	Max.	Min.
LTE-FDD B1/B2/B3/B4/B5/B8/B12/B13/B18/B19/B20/ B25/B26 ¹⁾ /B27 ¹⁾ /B28/B66/B71 ²⁾ /B85	23 dBm ±2 dB	< -39 dBm
GSM850/EGSM900	33 dBm ±2 dB	5 dBm ±5 dB
DCS1800/PCS1900	30 dBm ±2 dB	0 dBm ±5 dB
GSM850/EGSM900 (8-PSK)	27 dBm ±3 dB	5 dBm ±5 dB
DCS1800/PCS1900 (8-PSK)	26 dBm ±3 dB	0 dBm ±5 dB

NOTES

- ¹⁾ LTE-FDD B26 and B27 are supported by Cat M1 only.
- ²⁾ LTE-FDD B71 is supported by Cat NB2 only.
- ³⁾ LTE-FDD B31, B72 and B73 for BG95-M4 supports Power Class 2 (26 dBm) and Power Class 3 (23 dBm). Power Class 2 for BG95-M4 is under development.

6.6. RF Receiving Sensitivity

The following table shows the conducted RF receiving sensitivity of BG95 series module.

Table 51: Conducted RF Receiving Sensitivity of BG95-M1

Network	Band	Primary	Diversity	Sensitivity (dBm)	
				Cat M1/3GPP	Cat NB2
LTE	LTE-FDD B1	Supported	Not Supported	-108/-102.3	Not Supported
	LTE-FDD B2			-108.4/-100.3	
	LTE-FDD B3			-108.4/-99.3	
	LTE-FDD B4			-108/-102.3	
	LTE-FDD B5			-107.6/-100.8	
	LTE-FDD B8			-108/-99.8	
	LTE-FDD B12			-108.6/-99.3	
	LTE-FDD B13			-107/-99.3	
	LTE-FDD B18			-108/-102.3	
	LTE-FDD B19			-108/-102.3	
	LTE-FDD B20			-108/-99.8	
	LTE-FDD B25			-108.2/-100.3	
	LTE-FDD B26			-108.2/-100.3	
	LTE-FDD B27			-108.4/-100.8	
	LTE-FDD B28			-106.8/-100.8	
	LTE-FDD B66			-107.8/-101.8	
	LTE-FDD B71			Not Supported	
	LTE-FDD B85			-108.4/-99.3	

Table 52: Conducted RF Receiving Sensitivity of BG95-M2

Network	Band	Primary	Diversity	Sensitivity (dBm)	
				Cat M1/3GPP	Cat NB2 ¹⁾ /3GPP
LTE	LTE-FDD B1	Supported	Not Supported	-107/-102.3	-114/-107.5
	LTE-FDD B2			-107/-100.3	-116/-107.5
	LTE-FDD B3			-107/-99.3	-113/-107.5
	LTE-FDD B4			-107/-102.3	-114/-107.5
	LTE-FDD B5			-107/-100.8	-115/-107.5
	LTE-FDD B8			-107/-99.8	-113/-107.5
	LTE-FDD B12			-107/-99.3	-116/-107.5
	LTE-FDD B13			-107/-99.3	-114/-107.5
	LTE-FDD B18			-107/-102.3	-116/-107.5
	LTE-FDD B19			-107/-102.3	-116/-107.5
	LTE-FDD B20			-107/-99.8	-115/-107.5
	LTE-FDD B25			-107/-100.3	-115/-107.5
	LTE-FDD B26			-107/-100.3	Not Supported
	LTE-FDD B27			-107/-100.8	Not Supported
	LTE-FDD B28			-107/-100.8	-115/-107.5
	LTE-FDD B66			-107/-101.8	-115/-107.5
	LTE-FDD B71			Not Supported	-115/-107.5
LTE-FDD B85	-107/-99.3	-115/-107.5			

Table 53: Conducted RF Receiving Sensitivity of BG95-M3

Network	Band	Primary	Diversity	Sensitivity (dBm)	
				Cat M1/3GPP	Cat NB2 ¹ /3GPP
LTE	LTE-FDD B1	Supported	Not Supported	-106.5/-102.3	-113/-107.5
	LTE-FDD B2			-106/-100.3	-114/-107.5
	LTE-FDD B3			-106/-99.3	-114/-107.5
	LTE-FDD B4			-106.5/-102.3	-114/-107.5
	LTE-FDD B5			-106/-100.8	-115/-107.5
	LTE-FDD B8			-106/-99.8	-114/-107.5
	LTE-FDD B12			-106.5/-99.3	-115/-107.5
	LTE-FDD B13			-106.5/-99.3	-115/-107.5
	LTE-FDD B18			-106/-102.3	-115/-107.5
	LTE-FDD B19			-106/-102.3	-115/-107.5
	LTE-FDD B20			-106/-99.8	-114/-107.5
	LTE-FDD B25			-106/-100.3	-114/-107.5
	LTE-FDD B26			-106/-100.3	Not Supported
	LTE-FDD B27			-106.5/-100.8	Not Supported
	LTE-FDD B28			-106/-100.8	-115/-107.5
	LTE-FDD B66			-106.5/-101.8	-114/-107.5
	LTE-FDD B71			Not Supported	-115/-107.5
LTE-FDD B85	-106.5/-99.3	-115/-107.5			
Network	Band	Primary	Diversity	Sensitivity (dBm)	
				GSM/3GPP	
GSM	GSM850/EGSM900	Supported	Not Supported	-107/-102	
	DCS1800/PCS1900			-107/-102	

Table 54: Conducted RF Receiving Sensitivity of BG95-M5

Network	Band	Primary	Diversity	Sensitivity (dBm)	
				Cat M1/3GPP	Cat NB2 ¹ /3GPP
LTE	LTE-FDD B1	Supported	Not Supported	-106.5/-102.3	-114/-107.5
	LTE-FDD B2			-107.5/-100.3	-115/-107.5
	LTE-FDD B3			-108.0/-99.3	-114/-107.5
	LTE-FDD B4			-108.0/-102.3	-114/-107.5
	LTE-FDD B5			-107.5/-100.8	-114/-107.5
	LTE-FDD B8			-106.5/-99.8	-114/-107.5
	LTE-FDD B12			-106.5/-99.3	-114/-107.5
	LTE-FDD B13			-107.5/-99.3	-114/-107.5
	LTE-FDD B18			-107.5/-102.3	-115/-107.5
	LTE-FDD B19			-107.5/-102.3	-114/-107.5
	LTE-FDD B20			-107.5/-99.8	-114/-107.5
	LTE-FDD B25			-107.5/-100.3	-114/-107.5
	LTE-FDD B26			-107.5/-100.3	Not Supported
	LTE-FDD B27			-107.5/-100.8	Not Supported
	LTE-FDD B28			-107.5/-100.8	-114/-107.5
	LTE-FDD B66			-107.5/-101.8	-114/-107.5
	LTE-FDD B71			Not Supported	-115/-107.5
LTE-FDD B85	-107.5/-99.3	-114/-107.5			
Network	Band	Primary	Diversity	Sensitivity (dBm)	
				GSM/3GPP	
GSM	GSM850/EGSM900	Supported	Not Supported	-107/-102	
	DCS1800/PCS1900			-107/-102	

NOTES

1. ¹⁾ LTE Cat NB2 receiving sensitivity without repetitions.
2. “*” means under development.

6.7. Electrostatic Discharge

The module is not protected against electrostatics discharge (ESD) in general. Consequently, it is subject to ESD handling precautions that typically apply to ESD sensitive components. Proper ESD handling and packaging procedures must be applied throughout the processing, handling and operation of any application that incorporates the module.

The following table shows the electrostatic discharge characteristics of BG95 series module.

Table 55: Electrostatic Discharge Characteristics (25 °C, 45 % Relative Humidity)

Tested Interfaces	Contact Discharge	Air Discharge	Unit
VBAT, GND	± 6	± 8	kV
Main/GNSS Antenna Interfaces	± 5	± 6	kV

7 Mechanical Dimensions

This chapter describes the mechanical dimensions of the module. All dimensions are measured in millimeter (mm), and the dimensional tolerances are ± 0.05 mm unless otherwise specified.

7.1. Top and Side Dimensions

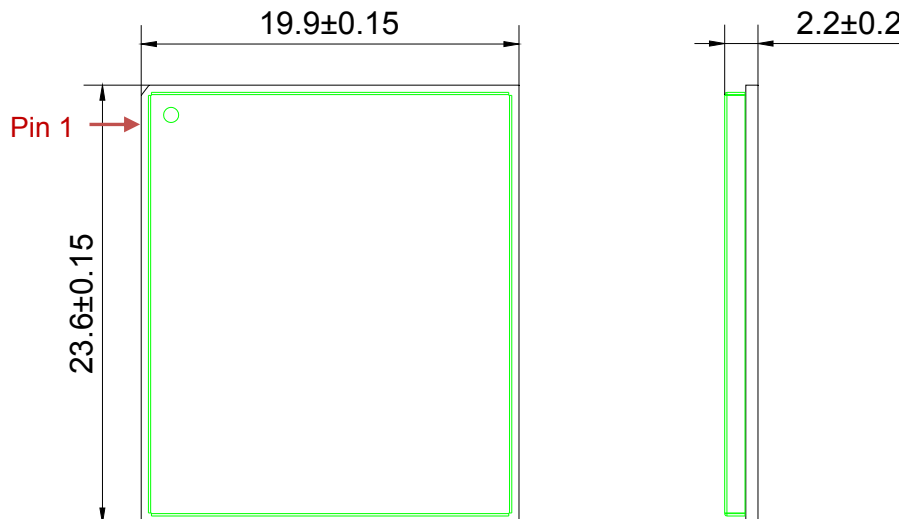

Figure 34: Module Top and Side Dimensions

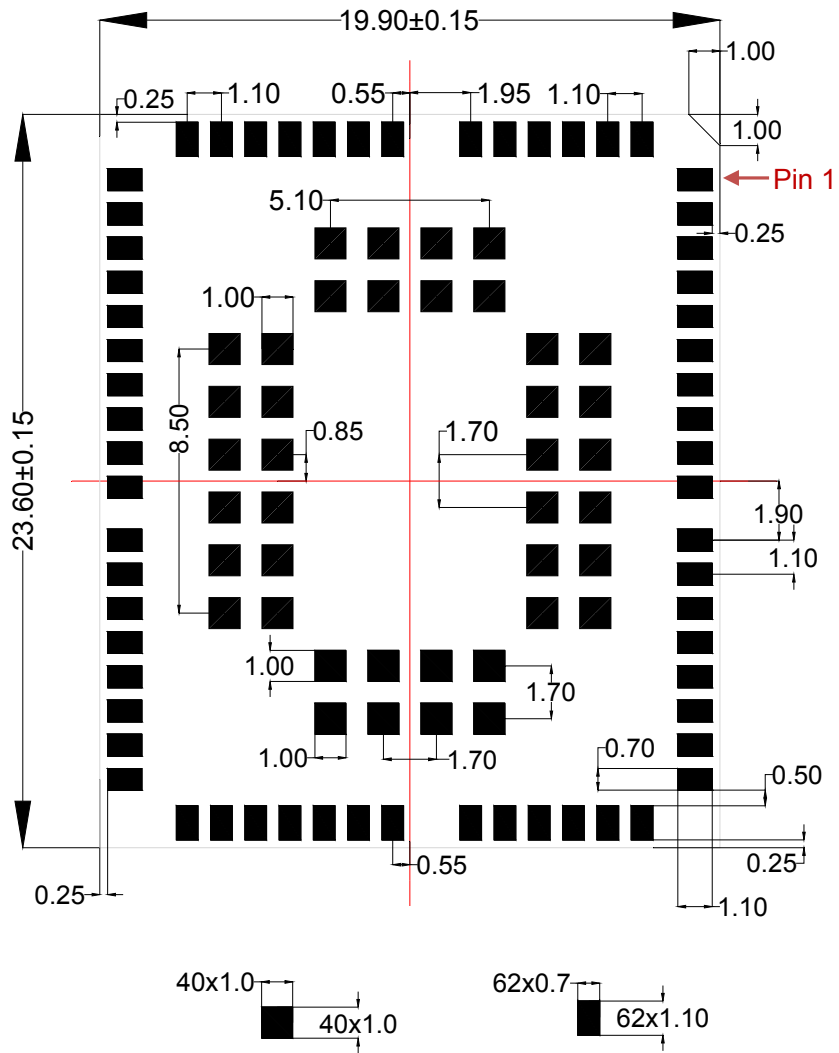

Figure 35: Module Bottom Dimensions (Bottom View)

NOTE

The package warpage level of the module conforms to *JEITA ED-7306* standard.

7.2. Recommended Footprint

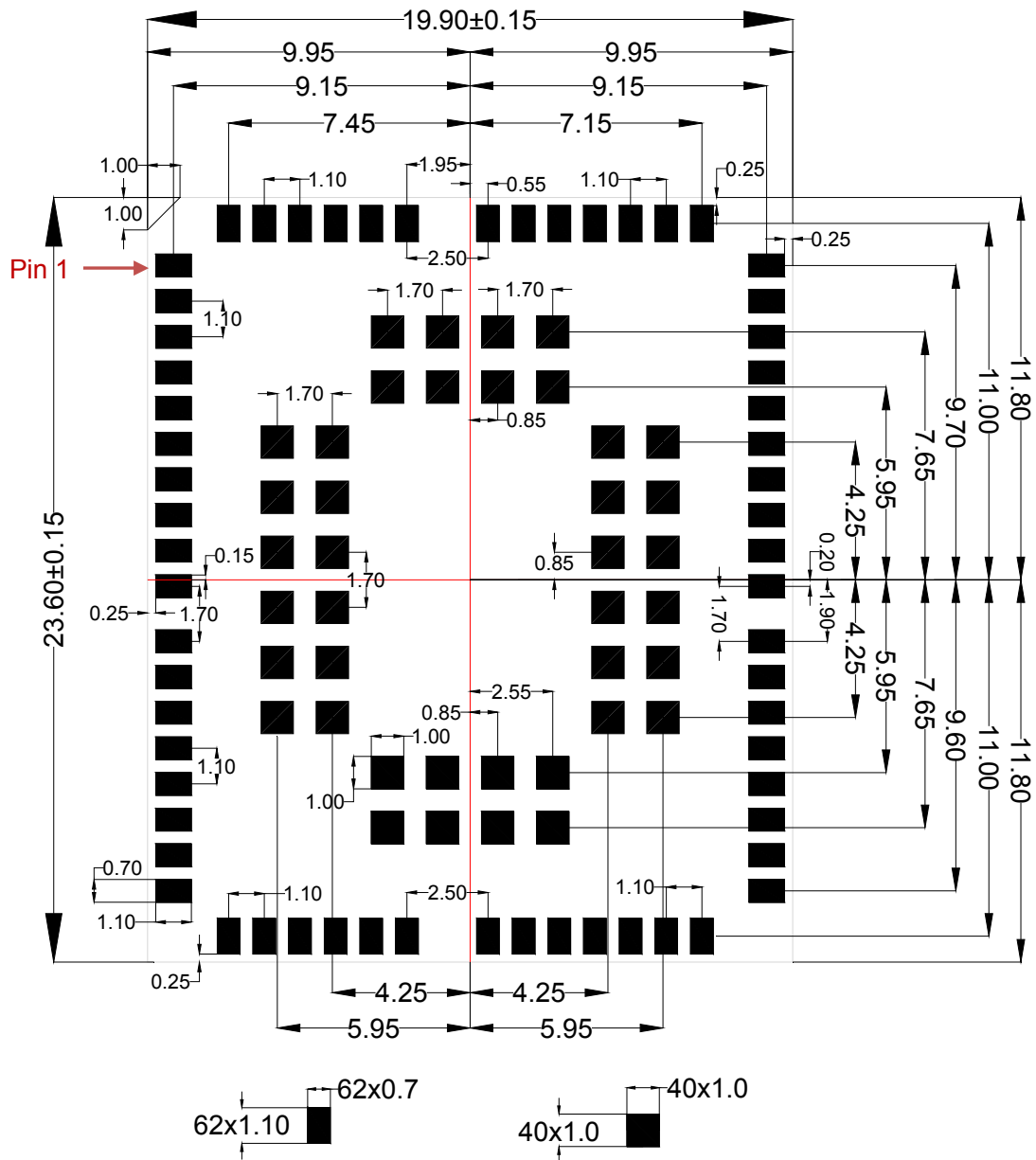

Figure 36: Recommended Footprint (Top View)

NOTES

1. For easy maintenance of the module, please keep about 3 mm between the module and other components on the motherboard.
2. All RESERVED pins must be kept open.
3. For stencil design requirements of the module, see *document [5]*.

7.3. Top and Bottom Views



Figure 37: Top View of the Module

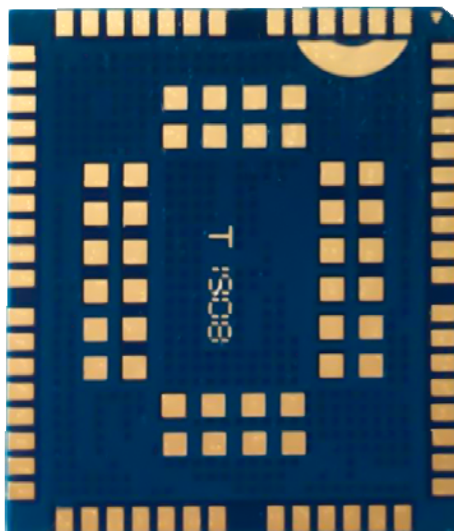

Figure 38: Bottom View of the Module

NOTE

These are renderings of BG95 module. For authentic appearance, see the module that you receive from Quectel.

8 Storage, Manufacturing and Packaging

8.1. Storage

BG95 series module is provided with vacuum-sealed packaging. MSL of the module is rated as 3. The storage requirements are shown below.

1. Recommended Storage Condition: The temperature should be 23 ± 5 °C and the relative humidity should be 35 % to 60 %.
2. The storage life (in vacuum-sealed packaging) is 12 months in Recommended Storage Condition.
3. The floor life of the module is 168 hours ¹⁾ in a plant where the temperature is 23 ± 5 °C and relative humidity is below 60 %. After the vacuum-sealed packaging is removed, the module must be processed in reflow soldering or other high-temperature operations within 168 hours. Otherwise, the module should be stored in an environment where the relative humidity is less than 10 % (e.g. a drying cabinet).
4. The module should be pre-baked to avoid blistering, cracks and inner-layer separation in PCB under the following circumstances:
 - The module is not stored in Recommended Storage Condition;
 - Violation of the third requirement above occurs;
 - Vacuum-sealed packaging is broken, or the packaging has been removed for over 24 hours;
 - Before module repairing.
5. If needed, the pre-baking should follow the requirements below:
 - The module should be baked for 8 hours at 120 ± 5 °C;
 - All modules must be soldered to PCB within 24 hours after the baking, otherwise they should be put in a dry environment such as in a drying oven.

NOTES

1. ¹⁾ This floor life is only applicable when the environment conforms to *IPC/JEDEC J-STD-033*.
2. To avoid blistering, layer separation and other soldering issues, it is forbidden to expose the modules to the air for a long time. If the temperature and moisture do not conform to *IPC/JEDEC J-STD-033* or the relative moisture is over 60 %, it is recommended to start the solder reflow process within 24 hours after the package is removed. And do not remove the packages of tremendous modules if they are not ready for soldering.
3. Take the module out of the packaging and put it on high-temperature resistant fixtures before the baking. If shorter baking time is desired, refer to *IPC/JEDEC J-STD-033* for baking procedure.

8.2. Manufacturing and Soldering

Push the squeegee to apply the solder paste on the surface of stencil, thus making the paste fill the stencil openings and then penetrate to the PCB. The force on the squeegee should be adjusted properly so as to produce a clean stencil surface on a single pass. To ensure the module soldering quality, the thickness of stencil for the module is recommended to be 0.13–0.15 mm. For more details, please refer to **document [5]**.

It is suggested that the peak reflow temperature is 238–246 °C, and the absolute maximum reflow temperature is 246 °C. To avoid damage to the module caused by repeated heating, it is strongly recommended that the module should be mounted after reflow soldering for the other side of PCB has been completed. The recommended reflow soldering thermal profile (lead-free reflow soldering) and related parameters are shown below.

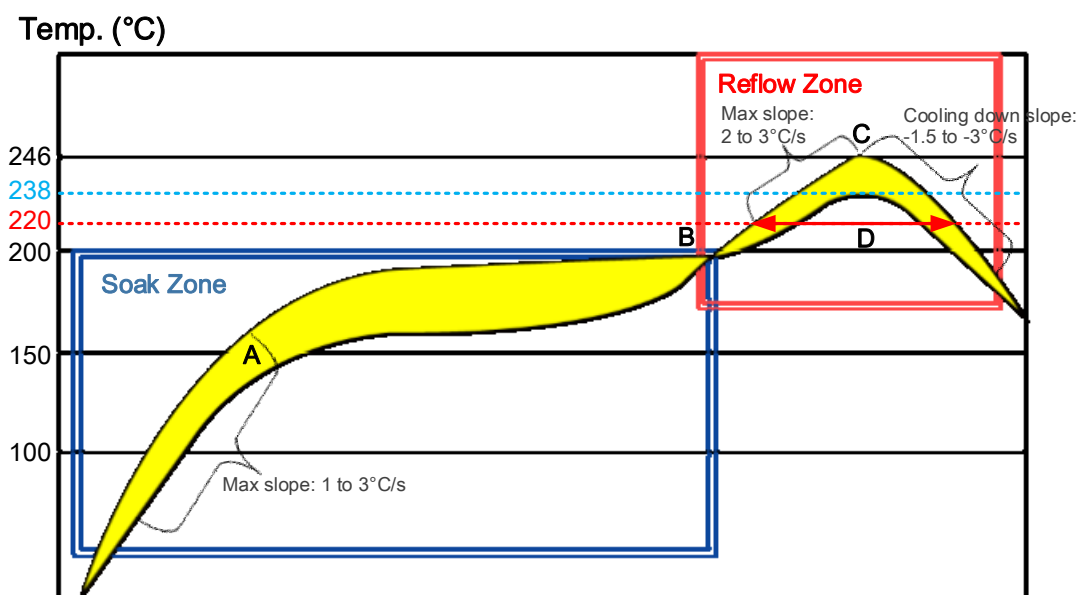

Figure 39: Recommended Reflow Soldering Thermal Profile

Table 56: Recommended Thermal Profile Parameters

Factor	Recommendation
Soak Zone	
Max slope	1–3 °C/s
Soak time (between A and B: 150 °C and 200 °C)	70–120 s
Reflow Zone	
Max slope	2–3 °C/s
Reflow time (D: over 220 °C)	45–70 s
Max temperature	238–246 °C
Cooling down slope	-1.5 to -3 °C/s
Reflow Cycle	
Max reflow cycle	1

8.3. Packaging

BG95 is packaged in a vacuum-sealed bag which is ESD protected. The bag should not be opened until the devices are ready to be soldered onto the application.

The reel is 330 mm in diameter and each reel contains 250 modules. The following figures show the packaging details, measured in millimeter (mm).

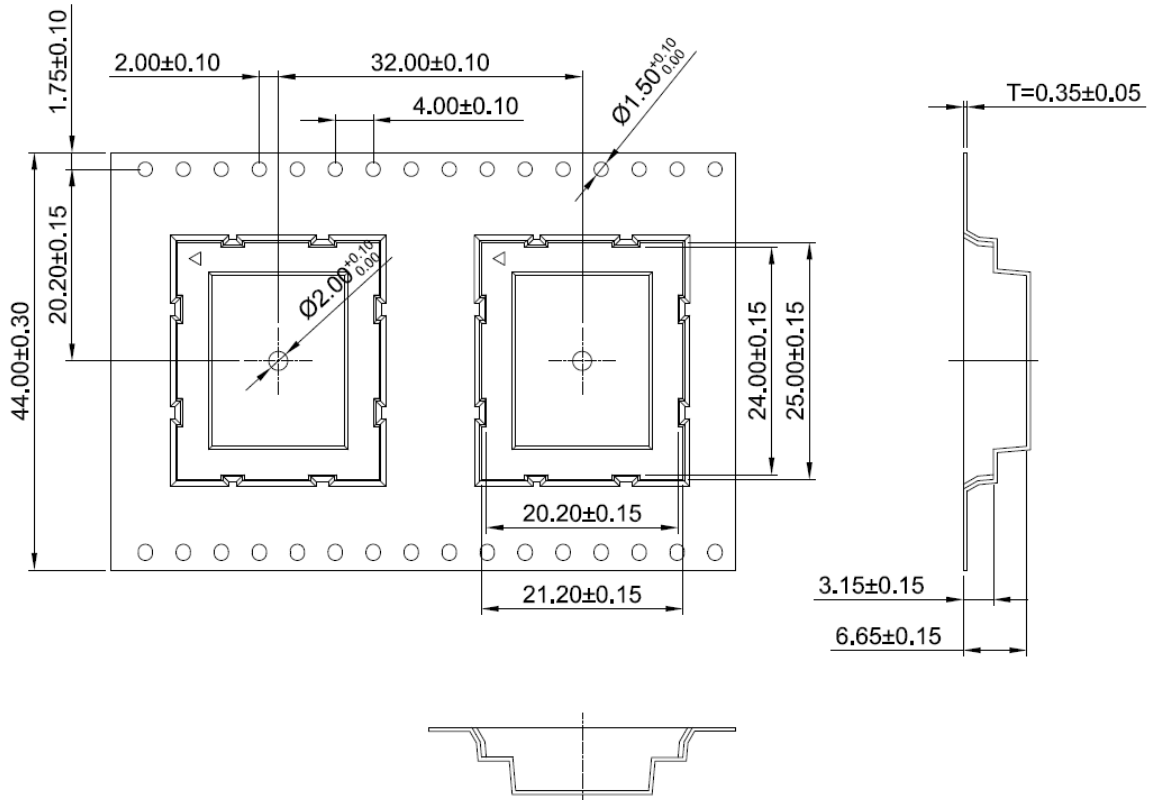

Figure 40: Tape Dimensions

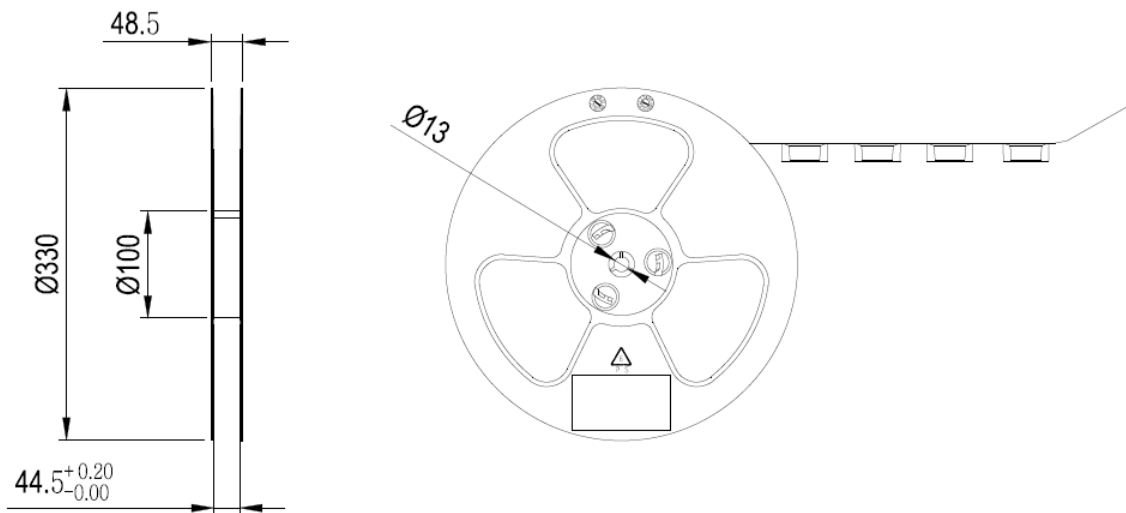

Figure 41: Reel Dimensions

Table 57: Packaging Specifications of BG95

MOQ for MP	Minimum Package: 250	Minimum Package × 4 = 1000
250	Size: 370 mm × 350 mm × 56 mm N.W: 0.61 kg G.W: 1.35 kg	Size: 380 mm × 250 mm × 365 mm N.W: 2.45 kg G.W: 6.28 kg

9 Appendix A References

Table 58: Related Documents

SN	Document Name	Remark
[1]	Quectel_UMTS<E_EVB_User_Guide	UMTS<E EVB user guide
[2]	Quectel_BG95&BG77_AT_Commands_Manual	AT commands manual of BG95 series and BG77 modules
[3]	Quectel_BG95&BG77&BG600L_Series_GNSS_Application_Note	GNSS application note of BG95 series, BG77 and BG600L-M3 modules
[4]	Quectel_RF_Layout_Application_Note	RF layout application note
[5]	Quectel_Module_Secondary_SMT_Application_Note	Secondary SMT application note for Quectel modules

Table 59: Terms and Abbreviations

Abbreviation	Description
AMR	Adaptive Multi-rate
bps	Bits Per Second
CHAP	Challenge Handshake Authentication Protocol
CS	Coding Scheme
CTS	Clear To Send
DFOTA	Delta Firmware Upgrade Over The Air
DL	Downlink
DTR	Data Terminal Ready
DTX	Discontinuous Transmission
e-I-DRX	Extended Idle Mode Discontinuous Reception

EPC	Evolved Packet Core
ESD	Electrostatic Discharge
FDD	Frequency Division Duplex
FR	Full Rate
GMSK	Gaussian Minimum Shift Keying
GSM	Global System for Mobile Communications
HSS	Home Subscriber Server
I/O	Input/Output
Inorm	Normal Current
LED	Light Emitting Diode
LNA	Low Noise Amplifier
LTE	Long Term Evolution
MO	Mobile Originated
MS	Mobile Station (GSM engine)
MT	Mobile Terminated
PAP	Password Authentication Protocol
PCB	Printed Circuit Board
PDU	Protocol Data Unit
PPP	Point-to-Point Protocol
PSM	Power Saving Mode
RF	Radio Frequency
RHCP	Right Hand Circularly Polarized
Rx	Receive
SISO	Single Input Single Output
SMS	Short Message Service

TDD	Time Division Duplexing
TX	Transmitting Direction
UL	Uplink
UE	User Equipment
URC	Unsolicited Result Code
(U)SIM	(Universal) Subscriber Identity Module
V _{max}	Maximum Voltage Value
V _{norm}	Normal Voltage Value
V _{min}	Minimum Voltage Value
V _{IHmax}	Maximum Input High Level Voltage Value
V _{IHmin}	Minimum Input High Level Voltage Value
V _{ILmax}	Maximum Input Low Level Voltage Value
V _{ILmin}	Minimum Input Low Level Voltage Value
V _{Imax}	Absolute Maximum Input Voltage Value
V _{Imin}	Absolute Minimum Input Voltage Value
V _{OHmax}	Maximum Output High Level Voltage Value
V _{OHmin}	Minimum Output High Level Voltage Value
V _{OLmax}	Maximum Output Low Level Voltage Value
V _{OLmin}	Minimum Output Low Level Voltage Value
VSWR	Voltage Standing Wave Ratio

10 Appendix B GPRS Coding Schemes

Table 60: Description of Different Coding Schemes

Scheme	CS-1	CS-2	CS-3	CS-4
Code Rate	1/2	2/3	3/4	1
USF	3	3	3	3
Pre-coded USF	3	6	6	12
Radio Block excl.USF and BCS	181	268	312	428
BCS	40	16	16	16
Tail	4	4	4	-
Coded Bits	456	588	676	456
Punctured Bits	0	132	220	-
Data Rate Kb/s	9.05	13.4	15.6	21.4

11 Appendix C GPRS Multi-slot Classes

Twenty-nine classes of GPRS multi-slot modes are defined for MS in GPRS specification. Multi-slot classes are product dependent, and determine the maximum achievable data rates in both the uplink and downlink directions. Written as 3+1 or 2+2, the first number indicates the amount of downlink timeslots, while the second number indicates the amount of uplink timeslots. The active slots determine the total number of slots the GPRS device can use simultaneously for both uplink and downlink communications.

The description of different multi-slot classes is shown in the following table.

Table 61: GPRS Multi-slot Classes

Multislot Class	Downlink Slots	Uplink Slots	Active Slots
1	1	1	2
2	2	1	3
3	2	2	3
4	3	1	4
5	2	2	4
6	3	2	4
7	3	3	4
8	4	1	5
9	3	2	5
10	4	2	5
11	4	3	5
12	4	4	5
13	3	3	NA
14	4	4	NA

15	5	5	NA
16	6	6	NA
17	7	7	NA
18	8	8	NA
19	6	2	NA
20	6	3	NA
21	6	4	NA
22	6	4	NA
23	6	6	NA
24	8	2	NA
25	8	3	NA
26	8	4	NA
27	8	4	NA
28	8	6	NA
29	8	8	NA
30	5	1	6
31	5	2	6
32	5	3	6
33	5	4	6

12 Appendix D EDGE Modulation and Coding Schemes

Table 62: EDGE Modulation and Coding Schemes

Coding Schemes	Modulation	Coding Family	1 Timeslot	2 Timeslot	4 Timeslot
MCS-1	GMSK	C	8.80 kbps	17.60 kbps	35.20 kbps
MCS-2	GMSK	B	11.2 kbps	22.4 kbps	44.8 kbps
MCS-3	GMSK	A	14.8 kbps	29.6 kbps	59.2 kbps
MCS-4	GMSK	C	17.6 kbps	35.2 kbps	70.4 kbps
MCS-5	8-PSK	B	22.4 kbps	44.8 kbps	89.6 kbps
MCS-6	8-PSK	A	29.6 kbps	59.2 kbps	118.4 kbps
MCS-7	8-PSK	B	44.8 kbps	89.6 kbps	179.2 kbps
MCS-8	8-PSK	A	54.4 kbps	108.8 kbps	217.6 kbps
MCS-9	8-PSK	A	59.2 kbps	118.4 kbps	236.8 kbps

13 Appendix E Compulsory Certifications

By the issue date of the document, BG95-M5 has been certified by JATE and TELEC.

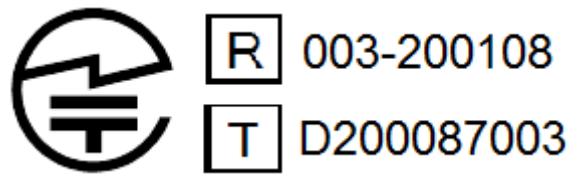

Figure 42: JATE/TELEC Certification ID of BG95-M5

FCC Certification Requirements.

According to the definition of mobile and fixed device is described in Part 2.1091(b), this device is a mobile device.

And the following conditions must be met:

1. This Modular Approval is limited to OEM installation for mobile and fixed applications only. The antenna installation and operating configurations of this transmitter, including any applicable source-based time-averaging duty factor, antenna gain and cable loss must satisfy MPE categorical Exclusion Requirements of 2.1091.

2. The EUT is a mobile device; maintain at least a 20 cm separation between the EUT and the user's body and must not transmit simultaneously with any other antenna or transmitter.

3. A label with the following statements must be attached to the host end product: This device contains FCC ID: XMR202012BG95MF.

4. To comply with FCC regulations limiting both maximum RF output power and human exposure to RF radiation, maximum antenna gain (including cable loss) must not exceed:

- Catm LTE Band2/25: ≤ 10.300 dBi
- Catm LTE Band4/66: ≤ 7.300 dBi
- Catm LTE Band5/26 part 22: ≤ 11.716 dBi
- Catm LTE Band26 part 90 : ≤ 11.637 dBi
- Catm LTE Band12: ≤ 11.034 dBi
- Catm LTE Band13: ≤ 11.473 dBi
- Catm LTE Band85: ≤ 11.034 dBi
- NB LTE Band2/25: ≤ 10.300 dBi
- NB LTE Band4/66: ≤ 7.300 dBi
- NB LTE Band5: ≤ 11.716 dBi
- NB LTE Band12: ≤ 11.034 dBi
- NB LTE Band13: ≤ 11.473 dBi
- NB LTE Band71: ≤ 10.747 dBi
- NB LTE Band85: ≤ 11.034 dBi

5. This module must not transmit simultaneously with any other antenna or transmitter

6. The host end product must include a user manual that clearly defines operating requirements and conditions that must be observed to ensure compliance with current FCC RF exposure guidelines.

For portable devices, in addition to the conditions 3 through 6 described above, a separate approval is required to satisfy the SAR requirements of FCC Part 2.1093

If the device is used for other equipment that separate approval is required for all other operating configurations, including portable configurations with respect to 2.1093 and different antenna configurations.

For this device, OEM integrators must be provided with labeling instructions of finished products.

Please refer to KDB784748 D01 v07, section 8. Page 6/7 last two paragraphs:

A certified modular has the option to use a permanently affixed label, or an electronic label. For a permanently affixed label, the module must be labeled with an FCC ID - Section 2.926 (see 2.2 Certification (labeling requirements) above). The OEM manual must provide clear instructions explaining to the OEM the labeling requirements, options and OEM user manual instructions that are required (see next paragraph).

For a host using a certified modular with a standard fixed label, if (1) the module's FCC ID is not visible when installed in the host, or (2) if the host is marketed so that end users do not have straightforward commonly used methods for access to remove the module so that the FCC ID of the module is visible; then an additional permanent label referring to the enclosed module: "Contains Transmitter Module FCC ID: XMR202012BG95MF" or "Contains FCC ID: XMR202012BG95MF" must be used. The host OEM user manual must also contain clear instructions on how end users can find and/or access the module and the FCC ID.

The final host / module combination may also need to be evaluated against the FCC Part 15B criteria for unintentional radiators in order to be properly authorized for operation as a Part 15 digital device.

The user's manual or instruction manual for an intentional or unintentional radiator shall caution the user that changes or modifications not expressly approved by the party responsible for compliance could void the user's authority to operate the equipment. In cases where the manual is provided only in a form other than paper, such as on a computer disk or over the Internet, the information required by this section may be included in the manual in that alternative form, provided the user can reasonably be expected to have the capability to access information in that form.

This device complies with part 15 of the FCC Rules. Operation is subject to the following two conditions: (1) This device may not cause harmful interference, and (2) this device must accept any interference received, including interference that may cause undesired operation.

Changes or modifications not expressly approved by the manufacturer could void the user's authority to operate the equipment.

13.1. IC Statement

IRSS-GEN

"This device complies with Industry Canada's licence-exempt RSSs. Operation is subject to the following two conditions: (1) This device may not cause interference; and (2) This device must accept any interference, including interference that may cause undesired operation of the device." or "Le présent appareil est conforme aux CNR d'Industrie Canada applicables aux appareils radio exempts de licence.

L'exploitation est autorisée aux deux conditions suivantes :

1) l'appareil ne doit pas produire de brouillage; 2) l'utilisateur de l'appareil doit accepter tout brouillage radioélectrique subi, même si le brouillage est susceptible d'en compromettre le fonctionnement."

Déclaration sur l'exposition aux rayonnements RF

The EUT is a mobile device; maintain at least a 20 cm separation between the EUT and the user's body and must not transmit simultaneously with any other antenna or transmitter.

L'autre utilisé pour l'émetteur doit être installé pour fournir une distance de séparation d'au moins 20 cm de toutes les personnes et ne doit pas être colocalisé ou fonctionner conjointement avec une autre

antenne ou un autre émetteur.

To comply with IC regulations limiting both maximum RF output power and human exposure to RF radiation, maximum antenna gain (including cable loss) must not exceed:

- Catm LTE Band2/25: ≤ 8.000 dBi
- Catm LTE Band4/66: ≤ 5.000 dBi
- Catm LTE Band5/26: ≤ 9.541 dBi
- Catm LTE Band12: ≤ 8.798 dBi
- Catm LTE Band13: ≤ 9.214 dBi
- Catm LTE Band85: ≤ 8.798 dBi
- NB LTE Band2/25: ≤ 8.000 dBi
- NB LTE Band4/66: ≤ 5.000 dBi
- NB LTE Band5: ≤ 9.541 dBi
- NB LTE Band12: ≤ 8.798 dBi
- NB LTE Band13: ≤ 9.214 dBi
- NB LTE Band71: ≤ 8.687 dBi
- NB LTE Band85: ≤ 8.798 dBi

The host product shall be properly labelled to identify the modules within the host product.

The Innovation, Science and Economic Development Canada certification label of a module shall be clearly visible at all times when installed in the host product; otherwise, the host product must be labeled to display the Innovation, Science and Economic Development Canada certification number for the module, preceded by the word "Contains" or similar wording expressing the same meaning, as follows: "Contains IC: 10224A-2020BG95MF" or "where: 10224A-2020BG95MF is the module's certification number".

Le produit hôte doit être correctement étiqueté pour identifier les modules dans le produit hôte.

L'étiquette de certification d'Innovation, Sciences et Développement économique Canada d'un module doit être clairement visible en tout temps lorsqu'il est installé dans le produit hôte; sinon, le produit hôte doit porter une étiquette indiquant le numéro de certification d'Innovation, Sciences et Développement économique Canada pour le module, précédé du mot «Contient» ou d'un libellé semblable exprimant la même signification, comme suit: "Contient IC: 10224A-2020BG95MF " ou "où: 10224A-2020BG95MF est le numéro de certification du module.