



# RF TEST REPORT

**Applicant**      Quectel Wireless Solutions Co., Ltd  
**FCC ID**          XMR202006EC25AUX  
**Product**        LTE Module  
**Brand**            Quectel  
**Model**            EC25-AUX, EC25-AUX MINIPCIE  
**Report No.**      R2108A0762-R3  
**Issue Date**     December 1, 2021

TA Technology (Shanghai) Co., Ltd. tested the above equipment in accordance with the requirements in **FCC CFR47 Part 2 (2020)/ FCC CFR47 Part 27C (2020)**. The test results show that the equipment tested is capable of demonstrating compliance with the requirements as documented in this report.

*Performed by: Peng Tao*

*Approved by: Kai Xu*

---

## TA Technology (Shanghai) Co., Ltd.

*No.145, Jintang Rd, Tangzhen Industry Park, Pudong Shanghai, China*

*TEL: +86-021-50791141/2/3*

*FAX: +86-021-50791141/2/3-8000*



## TABLE OF CONTENT

1	Test Laboratory.....	5
1.1	Notes of the Test Report.....	5
1.2.	Test facility.....	5
1.3	Testing Location.....	5
2	General Description of Equipment under Test.....	6
2.1	Applicant and Manufacturer Information.....	6
2.2	General information.....	6
3	Applied Standards.....	7
4	Test Configuration.....	8
5	Test Case Results.....	9
5.1	RF Power Output and Effective Isotropic Radiated Power.....	9
5.2	Occupied Bandwidth.....	22
5.3	Band Edge Compliance.....	35
5.4	Peak-to-Average Power Ratio (PAPR).....	51
5.5	Frequency Stability.....	54
5.6	Spurious Emissions at Antenna Terminals.....	61
5.7	Radiates Spurious Emission.....	78
6	Main Test Instruments.....	84
	ANNEX A: The EUT Appearance.....	86
	ANNEX B: Test Setup Photos.....	87
	ANNEX C: Product Change Description.....	88
	ANNEX D: Verify data.....	89



## Summary of Measurement Results

Number	Test Case	Clause in FCC rules	Verdict
1	RF Power Output and Effective Isotropic Radiated Power	2.1046 27.50(d)(4) /27.50(h)(2)	PASS
2	Occupied Bandwidth	2.1049	PASS
3	Band Edge Compliance	27.53(h) /27.53(m)	PASS
4	Peak-to-Average Power Ratio	27.50(d)/KDB971168 D01(5.7)	PASS
5	Frequency Stability	2.1055 / 27.54	PASS
6	Spurious Emissions at Antenna Terminals	2.1051 /27.53(h) /27.53(m)	PASS
7	Radiates Spurious Emission	2.1053 /27.53(h) /27.53(m)	PASS

Date of Testing: (Original) April 12, 2018~ April 18, 2018 and May 12, 2020~ May 13, 2020  
(Variant) September 28, 2021~ October 4, 2021

Note: PASS: The EUT complies with the essential requirements in the standard.

FAIL: The EUT does not comply with the essential requirements in the standard.

All indications of Pass/Fail in this report are opinions expressed by TA Technology (Shanghai) Co., Ltd. based on interpretations and/or observations of test results. Measurement Uncertainties were not taken into account and are published for informational purposes only.

**EC25-AUX, EC25-AUX MINIPCIE (Report No.: R2108A0762-R3) is a variant model of EC25-AUX, EC25-AUX MINIPCIE (Report No.: R2005A0269-R3). There is only changed the Power Amplifier and Software Version of product.**

**Tested cases refer to the following table. Please refer to Appendix C for Verify data**

Test Case	Original	Variant
RF Power Output and Effective Radiated Power	PASS	Retest(LTE band4/7)
Occupied Bandwidth	PASS	Verify the worst combination of each frequency band(LTE band4/7)
Band Edge Compliance	PASS	Verify the worst combination of each frequency band(LTE band4/7)
Peak-to-Average Power Ratio	PASS	Retest(LTE band4/7)
Frequency Stability	PASS	Retest(LTE band4/7)



Spurious Emissions at Antenna Terminals	PASS	Verify the worst combination of each frequency band(LTE band4/7)
Radiates Spurious Emission	PASS	Verify the worst combination of each frequency band(LTE band4/7)

**The detailed product change description please refers to the Difference Declaration Letter.**



# 1 Test Laboratory

## 1.1 Notes of the Test Report

This report shall not be reproduced in full or partial, without the written approval of **TA technology (shanghai) co., Ltd.** The results documented in this report apply only to the tested sample, under the conditions and modes of operation as described herein .Measurement Uncertainties were not taken into account and are published for informational purposes only. This report is written to support regulatory compliance of the applicable standards stated above.

## 1.2. Test facility

### **FCC (Designation number: CN1179, Test Firm Registration Number: 446626)**

TA Technology (Shanghai) Co., Ltd. has been listed on the US Federal Communications Commission list of test facilities recognized to perform electromagnetic emissions measurements.

### **A2LA (Certificate Number: 3857.01)**

TA Technology (Shanghai) Co., Ltd. has been listed by American Association for Laboratory Accreditation to perform electromagnetic emission measurement.

## 1.3 Testing Location

Company: TA Technology (Shanghai) Co., Ltd.  
Address: No.145, Jintang Rd, Tangzhen Industry Park, Pudong Shanghai, China  
City: Shanghai  
Post code: 201201  
Country: P. R. China  
Contact: Xu Kai  
Telephone: +86-021-50791141/2/3  
Fax: +86-021-50791141/2/3-8000  
Website: <http://www.ta-shanghai.com>  
E-mail: [xukai@ta-shanghai.com](mailto:xukai@ta-shanghai.com)

## 2 General Description of Equipment under Test

### 2.1 Applicant and Manufacturer Information

<b>Applicant</b>	Quectel Wireless Solutions Co., Ltd
<b>Applicant address</b>	Building 5, Shanghai Business Park Phase III (Area B), No.1016 Tianlin Road, Minhang District, Shanghai, China 200233
<b>Manufacturer</b>	Quectel Wireless Solutions Co., Ltd
<b>Manufacturer address</b>	Building 5, Shanghai Business Park Phase III (Area B), No.1016 Tianlin Road, Minhang District, Shanghai, China 200233

### 2.2 General information

EUT Description			
Model	EC25-AUX, EC25-AUX MINIPCIE		
IMEI:	862708040005709		
Hardware Version	R2.0		
Software Version	EC25AUXGAR08A05M1G		
Power Supply	External supply power		
Antenna Type	The EUT don't have standard Antenna, The Antenna used for testing in this report is the after-market accessory (Dipole Antenna)		
Antenna Gain	Band	Gain(dBi)	
	LTE Band 4	1.94	
	LTE Band 7	2.44	
Test Mode(s)	LTE Band 4; LTE Band 7;		
Test Modulation	(LTE)QPSK 16QAM;		
LTE Category	4		
Maximum E.I.R.P./ E.R.P.	LTE Band 4:	25.65dBm	
	LTE Band 7:	25.92dBm	
Rated Power Supply Voltage:	3.8 V		
Extreme Voltage	Minimum: 3.3 V Maximum: 4.3V		
Extreme Temperature	Lowest: -40°C Highest: +85°C		
Operating Frequency Range(s)	Mode	Tx (MHz)	Rx (MHz)
	LTE Band 4	1710 ~ 1755	2110 ~ 2155
	LTE Band 7	2500 ~ 2570	2620 ~ 2690
Note: 1. The EUT is sent from the applicant to TA and the information of the EUT is declared by the applicant.			

The series model number is: EC25-AUX MINIPCIE. The difference of these models are have different marketing requirement.



### 3 Applied Standards

According to the specifications of the manufacturer, it must comply with the requirements of the following standards:

**Test standards:**

**FCC CFR47 Part 27C (2020)**

**FCC CFR47 Part 2 (2020)**

**Reference standard:**

**ANSI C63.26 (2015)**

**KDB 971168 D01 Power Meas License Digital Systems v03r01**

## 4 Test Configuration

Radiated measurements are performed by rotating the EUT in three different orthogonal test planes. EUT stand-up position (Z axis), lie-down position (X, Y axis). Receiver antenna polarization (horizontal and vertical), the worst emission was found in position (Z axis, horizontal polarization) and the worst case was recorded.

All mode and data rates and positions and RB size and modulations were investigated. Subsequently, only the worst case emissions are reported.

The following testing in LTE is set based on the maximum RF Output Power.

The following testing in different Bandwidth is set to detail in the following table:

Test modes are chosen to be reported as the worst case configuration below for LTE Band 4/7:

Test items	Modes	Bandwidth (MHz)						Modulation		RB			Test Channel			
		1.4	3	5	10	15	20	QPSK	16QAM	1	50%	100%	L	M	H	
RF Power Output and Effective Isotropic Radiated Power	LTE 4	O	O	O	O	O	O	O	O	O	O	O	O	O	O	O
	LTE 7	-	-	O	O	O	O	O	O	O	O	O	O	O	O	O
Occupied Bandwidth	LTE 4	O	O	O	O	O	O	O	O	-	-	O	O	O	O	
	LTE 7	-	-	O	O	O	O	O	O	-	-	O	O	O	O	
Band Edge Compliance	LTE 4	O	O	O	O	O	O	O	O	O	-	O	O	-	O	
	LTE 7	-	-	O	O	O	O	O	O	O	-	O	O	-	O	
Peak-to-Average Power Ratio	LTE 4	O	O	O	O	O	O	O	O	-	-	O	O	O	O	
	LTE 7	-	-	O	O	O	O	O	O	-	-	O	O	O	O	
Frequency Stability	LTE 4	O	O	O	O	O	O	O	O	O	O	O	O	O	O	
	LTE 7	-	-	O	O	O	O	O	O	O	O	O	O	O	O	
Spurious Emissions at Antenna Terminals	LTE 4	O	O	O	O	O	O	O	-	O	-	-	O	O	O	
	LTE 7	-	-	O	O	O	O	O	-	O	-	-	O	O	O	
Radiates Spurious Emission	LTE 4	O	-	O	-	-	O	O	-	O	-	-	-	O	-	
	LTE 7	-	-	O	-	O	O	O	-	O	-	-	-	O	-	
Note	1. The mark "O" means that this configuration is chosen for testing. 2. The mark "-" means that this configuration is not testing.															



## 5 Test Case Results

### 5.1 RF Power Output and Effective Isotropic Radiated Power

#### Ambient condition

Temperature	Relative humidity	Pressure
23°C ~25°C	45%~50%	101.5kPa

#### Methods of Measurement

During the process of the testing, The EUT is controlled by the Base Station Simulator to ensure max power transmission and proper modulation.

1. The testing follows FCC KDB 971168 D01 v03r01 Section 5.8 and ANSI C63.26 (2015).

- a) Connect the equipment as illustrated. Mount the equipment with the manufacturer specified antenna in a vertical orientation on a manufacturer specified mounting surface located on a non-conducting rotating platform of a RF anechoic chamber (preferred) or a standard radiation site.
- b) Key the transmitter, then rotate the EUT 360° azimuthally and record spectrum analyzer power level (LVL) measurements at angular increments that are sufficiently small to permit resolution of all peaks. If a standard radiation test site is used, raise and lower the test antenna to obtain a maximum reading at each angular increment. (Note: several batteries may be needed to offset the effect of battery voltage droop, which should not exceed 5% of the manufactured specified battery voltage during transmission).
- c) Replace the transmitter under test with a vertically polarized half-wave dipole (or an antenna whose gain is known relative to an ideal half-wave dipole). The center of the antenna should be at the same location as the center of the antenna under test.
- d) Connect the antenna to a signal generator with a known output power and record the path loss (in dB) as LOSS. If a standard radiation test site is used, raise and lower the test antenna to obtain a maximum reading.  $LOSS = \text{Generator Output Power (dBm)} - \text{Analyzer reading (dBm)}$
- e) Determine the effective radiated output power at each angular position from the readings in steps b) and d) using the following equation:  $ERP \text{ (dBm)} = \text{LVL (dBm)} + \text{LOSS (dB)}$
- f) The maximum ERP is the maximum value determined in the preceding step.
- g) When calculating ERP, in addition to knowing the antenna radiation and matching characteristics, it is necessary to know the loss values of all elements (e.g. transmission line attenuation, mismatches, filters, combiners) interposed between the point where transmitter output power is measured, and the point where power is applied to the antenna. ERP can then be calculated as follows:

$$EIRP \text{ (dBm)} = \text{Output Power (dBm)} - \text{Losses (dB)} + \text{Antenna Gain (dBi)}$$

where: dBd refers to gain relative to an ideal dipole.

$$EIRP \text{ (dBm)} = ERP \text{ (dBm)} + 2.15 \text{ (dB.)}$$

The RB allocation refers to section 5.1, using the maximum output power configuration.

**Test Setup**

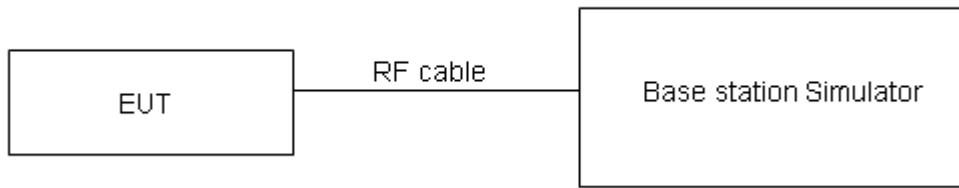

The loss between RF output port of the EUT and the input port of the tester has been taken into consideration.

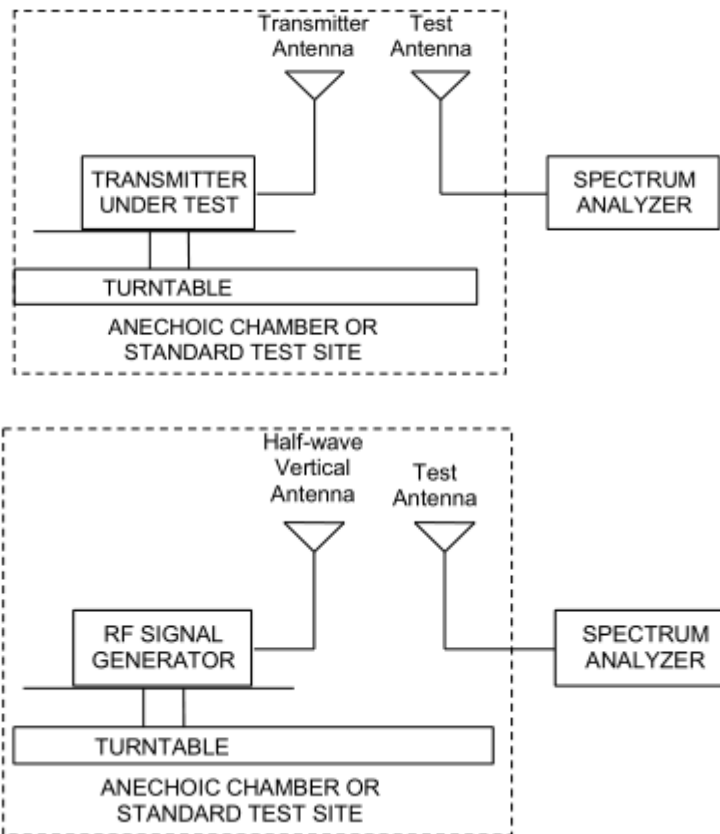

Note: Area side:2.4mX3.6m

The radiated emission was measured in the following position: EUT stand-up position (Z axis), lie-down position (X, Y axis). The worst emission was found in stand-up position (Z axis) and the worst case was recorded.

**Limits**

No specific RF power output requirements in part 2.1046.

Rule Part 27.50(d) (4) specifies that “Fixed, mobile and portable (hand-held) stations operating in the 1710–1755 MHz band are limited to 1 watt EIRP”

Rule Part 27.50(h) (2) specifies that “Mobile and other user stations. Mobile stations are limited to 2.0 watts EIRP. All user stations are limited to 2.0 watts transmitter output power.”



Part 27.50(d)(4)Limit	$\leq 1 \text{ W}$ (30 dBm)
Part 27.50(h)(2) Limit	$\leq 2 \text{ W}$ (33 dBm)

### Measurement Uncertainty

The assessed measurement uncertainty to ensure 95% confidence level for the normal distribution is with the coverage factor  $k = 2$ ,  $U=0.4$  dB for RF power output,  $k = 2$ ,  $U= 1.19$  dB for ERP/EIRP.



## Test Results

Band	Bandwidth (MHz)	UL Channel	RB Size	RB Position	Modulation	Power (dBm)	EIRP (dBm)	Verdict
LTE Band4	1.4	19957	1	#0	QPSK	23.35	25.29	PASS
LTE Band4	1.4	19957	1	#Mid	QPSK	23.43	25.37	PASS
LTE Band4	1.4	19957	1	#Max	QPSK	23.27	25.21	PASS
LTE Band4	1.4	19957	3	#0	QPSK	23.04	24.98	PASS
LTE Band4	1.4	19957	3	#Mid	QPSK	23.03	24.97	PASS
LTE Band4	1.4	19957	3	#Max	QPSK	22.99	24.93	PASS
LTE Band4	1.4	19957	6	#0	QPSK	22.18	24.12	PASS
LTE Band4	1.4	19957	1	#0	QAM16	22.21	24.15	PASS
LTE Band4	1.4	19957	1	#Mid	QAM16	22.40	24.34	PASS
LTE Band4	1.4	19957	1	#Max	QAM16	22.23	24.17	PASS
LTE Band4	1.4	19957	3	#0	QAM16	22.18	24.12	PASS
LTE Band4	1.4	19957	3	#Mid	QAM16	22.14	24.08	PASS
LTE Band4	1.4	19957	3	#Max	QAM16	22.05	23.99	PASS
LTE Band4	1.4	19957	6	#0	QAM16	21.26	23.20	PASS
LTE Band4	1.4	20175	1	#0	QPSK	22.83	24.77	PASS
LTE Band4	1.4	20175	1	#Mid	QPSK	23.07	25.01	PASS
LTE Band4	1.4	20175	1	#Max	QPSK	22.86	24.80	PASS
LTE Band4	1.4	20175	3	#0	QPSK	23.06	25.00	PASS
LTE Band4	1.4	20175	3	#Mid	QPSK	23.03	24.97	PASS
LTE Band4	1.4	20175	3	#Max	QPSK	22.99	24.93	PASS
LTE Band4	1.4	20175	6	#0	QPSK	22.08	24.02	PASS
LTE Band4	1.4	20175	1	#0	QAM16	22.68	24.62	PASS
LTE Band4	1.4	20175	1	#Mid	QAM16	22.84	24.78	PASS
LTE Band4	1.4	20175	1	#Max	QAM16	22.30	24.24	PASS
LTE Band4	1.4	20175	3	#0	QAM16	21.89	23.83	PASS
LTE Band4	1.4	20175	3	#Mid	QAM16	21.88	23.82	PASS
LTE Band4	1.4	20175	3	#Max	QAM16	21.88	23.82	PASS
LTE Band4	1.4	20175	6	#0	QAM16	20.85	22.79	PASS
LTE Band4	1.4	20393	1	#0	QPSK	23.45	25.39	PASS
LTE Band4	1.4	20393	1	#Mid	QPSK	23.71	25.65	PASS
LTE Band4	1.4	20393	1	#Max	QPSK	23.59	25.53	PASS
LTE Band4	1.4	20393	3	#0	QPSK	23.42	25.36	PASS
LTE Band4	1.4	20393	3	#Mid	QPSK	23.42	25.36	PASS
LTE Band4	1.4	20393	3	#Max	QPSK	23.58	25.52	PASS
LTE Band4	1.4	20393	6	#0	QPSK	22.37	24.31	PASS
LTE Band4	1.4	20393	1	#0	QAM16	22.15	24.09	PASS
LTE Band4	1.4	20393	1	#Mid	QAM16	22.61	24.55	PASS
LTE Band4	1.4	20393	1	#Max	QAM16	22.43	24.37	PASS
LTE Band4	1.4	20393	3	#0	QAM16	22.56	24.50	PASS



LTE Band4	1.4	20393	3	#Mid	QAM16	22.55	24.49	PASS
LTE Band4	1.4	20393	3	#Max	QAM16	22.74	24.68	PASS
LTE Band4	1.4	20393	6	#0	QAM16	21.31	23.25	PASS
LTE Band4	3	19965	1	#0	QPSK	22.61	24.55	PASS
LTE Band4	3	19965	1	#Mid	QPSK	22.53	24.47	PASS
LTE Band4	3	19965	1	#Max	QPSK	22.82	24.76	PASS
LTE Band4	3	19965	8	#0	QPSK	21.71	23.65	PASS
LTE Band4	3	19965	8	#Mid	QPSK	21.81	23.75	PASS
LTE Band4	3	19965	8	#Max	QPSK	21.93	23.87	PASS
LTE Band4	3	19965	15	#0	QPSK	21.96	23.90	PASS
LTE Band4	3	19965	1	#0	QAM16	21.92	23.86	PASS
LTE Band4	3	19965	1	#Mid	QAM16	21.78	23.72	PASS
LTE Band4	3	19965	1	#Max	QAM16	22.24	24.18	PASS
LTE Band4	3	19965	8	#0	QAM16	20.56	22.50	PASS
LTE Band4	3	19965	8	#Mid	QAM16	20.77	22.71	PASS
LTE Band4	3	19965	8	#Max	QAM16	20.67	22.61	PASS
LTE Band4	3	19965	15	#0	QAM16	21.00	22.94	PASS
LTE Band4	3	20175	1	#0	QPSK	22.84	24.78	PASS
LTE Band4	3	20175	1	#Mid	QPSK	22.58	24.52	PASS
LTE Band4	3	20175	1	#Max	QPSK	22.69	24.63	PASS
LTE Band4	3	20175	8	#0	QPSK	21.73	23.67	PASS
LTE Band4	3	20175	8	#Mid	QPSK	21.82	23.76	PASS
LTE Band4	3	20175	8	#Max	QPSK	21.88	23.82	PASS
LTE Band4	3	20175	15	#0	QPSK	21.86	23.80	PASS
LTE Band4	3	20175	1	#0	QAM16	22.22	24.16	PASS
LTE Band4	3	20175	1	#Mid	QAM16	22.61	24.55	PASS
LTE Band4	3	20175	1	#Max	QAM16	22.19	24.13	PASS
LTE Band4	3	20175	8	#0	QAM16	20.92	22.86	PASS
LTE Band4	3	20175	8	#Mid	QAM16	20.93	22.87	PASS
LTE Band4	3	20175	8	#Max	QAM16	20.89	22.83	PASS
LTE Band4	3	20175	15	#0	QAM16	20.94	22.88	PASS
LTE Band4	3	20385	1	#0	QPSK	23.43	25.37	PASS
LTE Band4	3	20385	1	#Mid	QPSK	23.01	24.95	PASS
LTE Band4	3	20385	1	#Max	QPSK	23.37	25.31	PASS
LTE Band4	3	20385	8	#0	QPSK	22.09	24.03	PASS
LTE Band4	3	20385	8	#Mid	QPSK	22.10	24.04	PASS
LTE Band4	3	20385	8	#Max	QPSK	22.17	24.11	PASS
LTE Band4	3	20385	15	#0	QPSK	22.24	24.18	PASS
LTE Band4	3	20385	1	#0	QAM16	22.13	24.07	PASS
LTE Band4	3	20385	1	#Mid	QAM16	21.86	23.80	PASS
LTE Band4	3	20385	1	#Max	QAM16	22.28	24.22	PASS
LTE Band4	3	20385	8	#0	QAM16	20.91	22.85	PASS
LTE Band4	3	20385	8	#Mid	QAM16	20.92	22.86	PASS



LTE Band4	3	20385	8	#Max	QAM16	20.79	22.73	PASS
LTE Band4	3	20385	15	#0	QAM16	21.15	23.09	PASS
LTE Band4	5	19975	1	#0	QPSK	23.10	25.04	PASS
LTE Band4	5	19975	1	#Mid	QPSK	23.18	25.12	PASS
LTE Band4	5	19975	1	#Max	QPSK	23.25	25.19	PASS
LTE Band4	5	19975	12	#0	QPSK	21.99	23.93	PASS
LTE Band4	5	19975	12	#Mid	QPSK	22.09	24.03	PASS
LTE Band4	5	19975	12	#Max	QPSK	22.16	24.10	PASS
LTE Band4	5	19975	25	#0	QPSK	22.12	24.06	PASS
LTE Band4	5	19975	1	#0	QAM16	22.55	24.49	PASS
LTE Band4	5	19975	1	#Mid	QAM16	21.92	23.86	PASS
LTE Band4	5	19975	1	#Max	QAM16	22.23	24.17	PASS
LTE Band4	5	19975	12	#0	QAM16	20.98	22.92	PASS
LTE Band4	5	19975	12	#Mid	QAM16	20.98	22.92	PASS
LTE Band4	5	19975	12	#Max	QAM16	20.95	22.89	PASS
LTE Band4	5	19975	25	#0	QAM16	21.18	23.12	PASS
LTE Band4	5	20175	1	#0	QPSK	23.11	25.05	PASS
LTE Band4	5	20175	1	#Mid	QPSK	22.94	24.88	PASS
LTE Band4	5	20175	1	#Max	QPSK	22.95	24.89	PASS
LTE Band4	5	20175	12	#0	QPSK	22.17	24.11	PASS
LTE Band4	5	20175	12	#Mid	QPSK	22.17	24.11	PASS
LTE Band4	5	20175	12	#Max	QPSK	22.09	24.03	PASS
LTE Band4	5	20175	25	#0	QPSK	22.12	24.06	PASS
LTE Band4	5	20175	1	#0	QAM16	22.29	24.23	PASS
LTE Band4	5	20175	1	#Mid	QAM16	21.85	23.79	PASS
LTE Band4	5	20175	1	#Max	QAM16	22.16	24.10	PASS
LTE Band4	5	20175	12	#0	QAM16	20.96	22.90	PASS
LTE Band4	5	20175	12	#Mid	QAM16	20.96	22.90	PASS
LTE Band4	5	20175	12	#Max	QAM16	20.87	22.81	PASS
LTE Band4	5	20175	25	#0	QAM16	21.04	22.98	PASS
LTE Band4	5	20375	1	#0	QPSK	23.25	25.19	PASS
LTE Band4	5	20375	1	#Mid	QPSK	23.00	24.94	PASS
LTE Band4	5	20375	1	#Max	QPSK	23.30	25.24	PASS
LTE Band4	5	20375	12	#0	QPSK	22.16	24.10	PASS
LTE Band4	5	20375	12	#Mid	QPSK	22.17	24.11	PASS
LTE Band4	5	20375	12	#Max	QPSK	22.09	24.03	PASS
LTE Band4	5	20375	25	#0	QPSK	22.18	24.12	PASS
LTE Band4	5	20375	1	#0	QAM16	22.20	24.14	PASS
LTE Band4	5	20375	1	#Mid	QAM16	22.21	24.15	PASS
LTE Band4	5	20375	1	#Max	QAM16	22.44	24.38	PASS
LTE Band4	5	20375	12	#0	QAM16	21.04	22.98	PASS
LTE Band4	5	20375	12	#Mid	QAM16	21.05	22.99	PASS
LTE Band4	5	20375	12	#Max	QAM16	21.05	22.99	PASS



LTE Band4	5	20375	25	#0	QAM16	21.14	23.08	PASS
LTE Band4	10	20000	1	#0	QPSK	22.98	24.92	PASS
LTE Band4	10	20000	1	#Mid	QPSK	23.34	25.28	PASS
LTE Band4	10	20000	1	#Max	QPSK	23.34	25.28	PASS
LTE Band4	10	20000	25	#0	QPSK	22.24	24.18	PASS
LTE Band4	10	20000	25	#Mid	QPSK	22.16	24.10	PASS
LTE Band4	10	20000	25	#Max	QPSK	22.26	24.20	PASS
LTE Band4	10	20000	50	#0	QPSK	22.13	24.07	PASS
LTE Band4	10	20000	1	#0	QAM16	22.09	24.03	PASS
LTE Band4	10	20000	1	#Mid	QAM16	22.26	24.20	PASS
LTE Band4	10	20000	1	#Max	QAM16	22.42	24.36	PASS
LTE Band4	10	20000	25	#0	QAM16	21.20	23.14	PASS
LTE Band4	10	20000	25	#Mid	QAM16	21.29	23.23	PASS
LTE Band4	10	20000	25	#Max	QAM16	21.15	23.09	PASS
LTE Band4	10	20000	50	#0	QAM16	21.12	23.06	PASS
LTE Band4	10	20175	1	#0	QPSK	23.01	24.95	PASS
LTE Band4	10	20175	1	#Mid	QPSK	23.03	24.97	PASS
LTE Band4	10	20175	1	#Max	QPSK	22.97	24.91	PASS
LTE Band4	10	20175	25	#0	QPSK	22.13	24.07	PASS
LTE Band4	10	20175	25	#Mid	QPSK	22.13	24.07	PASS
LTE Band4	10	20175	25	#Max	QPSK	22.05	23.99	PASS
LTE Band4	10	20175	50	#0	QPSK	22.11	24.05	PASS
LTE Band4	10	20175	1	#0	QAM16	22.71	24.65	PASS
LTE Band4	10	20175	1	#Mid	QAM16	22.70	24.64	PASS
LTE Band4	10	20175	1	#Max	QAM16	22.82	24.76	PASS
LTE Band4	10	20175	25	#0	QAM16	21.16	23.10	PASS
LTE Band4	10	20175	25	#Mid	QAM16	21.17	23.11	PASS
LTE Band4	10	20175	25	#Max	QAM16	21.19	23.13	PASS
LTE Band4	10	20175	50	#0	QAM16	21.17	23.11	PASS
LTE Band4	10	20350	1	#0	QPSK	23.02	24.96	PASS
LTE Band4	10	20350	1	#Mid	QPSK	23.03	24.97	PASS
LTE Band4	10	20350	1	#Max	QPSK	23.15	25.09	PASS
LTE Band4	10	20350	25	#0	QPSK	22.11	24.05	PASS
LTE Band4	10	20350	25	#Mid	QPSK	22.12	24.06	PASS
LTE Band4	10	20350	25	#Max	QPSK	22.22	24.16	PASS
LTE Band4	10	20350	50	#0	QPSK	22.23	24.17	PASS
LTE Band4	10	20350	1	#0	QAM16	21.86	23.80	PASS
LTE Band4	10	20350	1	#Mid	QAM16	21.51	23.45	PASS
LTE Band4	10	20350	1	#Max	QAM16	22.01	23.95	PASS
LTE Band4	10	20350	25	#0	QAM16	21.09	23.03	PASS
LTE Band4	10	20350	25	#Mid	QAM16	21.10	23.04	PASS
LTE Band4	10	20350	25	#Max	QAM16	21.12	23.06	PASS
LTE Band4	10	20350	50	#0	QAM16	21.21	23.15	PASS





LTE Band4	15	20025	1	#0	QPSK	23.35	25.29	PASS
LTE Band4	15	20025	1	#Mid	QPSK	23.32	25.26	PASS
LTE Band4	15	20025	1	#Max	QPSK	23.07	25.01	PASS
LTE Band4	15	20025	36	#0	QPSK	21.98	23.92	PASS
LTE Band4	15	20025	36	#Mid	QPSK	22.22	24.16	PASS
LTE Band4	15	20025	36	#Max	QPSK	22.23	24.17	PASS
LTE Band4	15	20025	75	#0	QPSK	22.34	24.28	PASS
LTE Band4	15	20025	1	#0	QAM16	21.91	23.85	PASS
LTE Band4	15	20025	1	#Mid	QAM16	21.99	23.93	PASS
LTE Band4	15	20025	1	#Max	QAM16	22.09	24.03	PASS
LTE Band4	15	20025	36	#0	QAM16	21.19	23.13	PASS
LTE Band4	15	20025	36	#Mid	QAM16	21.10	23.04	PASS
LTE Band4	15	20025	36	#Max	QAM16	21.28	23.22	PASS
LTE Band4	15	20025	75	#0	QAM16	21.18	23.12	PASS
LTE Band4	15	20175	1	#0	QPSK	22.99	24.93	PASS
LTE Band4	15	20175	1	#Mid	QPSK	22.85	24.79	PASS
LTE Band4	15	20175	1	#Max	QPSK	22.94	24.88	PASS
LTE Band4	15	20175	36	#0	QPSK	22.03	23.97	PASS
LTE Band4	15	20175	36	#Mid	QPSK	22.03	23.97	PASS
LTE Band4	15	20175	36	#Max	QPSK	22.03	23.97	PASS
LTE Band4	15	20175	75	#0	QPSK	22.00	23.94	PASS
LTE Band4	15	20175	1	#0	QAM16	22.57	24.51	PASS
LTE Band4	15	20175	1	#Mid	QAM16	22.41	24.35	PASS
LTE Band4	15	20175	1	#Max	QAM16	22.55	24.49	PASS
LTE Band4	15	20175	36	#0	QAM16	20.85	22.79	PASS
LTE Band4	15	20175	36	#Mid	QAM16	20.86	22.80	PASS
LTE Band4	15	20175	36	#Max	QAM16	20.86	22.80	PASS
LTE Band4	15	20175	75	#0	QAM16	21.03	22.97	PASS
LTE Band4	15	20325	1	#0	QPSK	23.09	25.03	PASS
LTE Band4	15	20325	1	#Mid	QPSK	22.93	24.87	PASS
LTE Band4	15	20325	1	#Max	QPSK	22.94	24.88	PASS
LTE Band4	15	20325	36	#0	QPSK	22.12	24.06	PASS
LTE Band4	15	20325	36	#Mid	QPSK	22.13	24.07	PASS
LTE Band4	15	20325	36	#Max	QPSK	22.00	23.94	PASS
LTE Band4	15	20325	75	#0	QPSK	22.12	24.06	PASS
LTE Band4	15	20325	1	#0	QAM16	21.70	23.64	PASS
LTE Band4	15	20325	1	#Mid	QAM16	21.85	23.79	PASS
LTE Band4	15	20325	1	#Max	QAM16	21.86	23.80	PASS
LTE Band4	15	20325	36	#0	QAM16	21.00	22.94	PASS
LTE Band4	15	20325	36	#Mid	QAM16	21.00	22.94	PASS
LTE Band4	15	20325	36	#Max	QAM16	21.00	22.94	PASS
LTE Band4	15	20325	75	#0	QAM16	21.16	23.10	PASS
LTE Band4	20	20050	1	#0	QPSK	22.99	24.93	PASS





LTE Band4	20	20050	1	#Mid	QPSK	23.13	25.07	PASS
LTE Band4	20	20050	1	#Max	QPSK	22.84	24.78	PASS
LTE Band4	20	20050	50	#0	QPSK	22.23	24.17	PASS
LTE Band4	20	20050	50	#Mid	QPSK	22.22	24.16	PASS
LTE Band4	20	20050	50	#Max	QPSK	22.07	24.01	PASS
LTE Band4	20	20050	100	#0	QPSK	22.14	24.08	PASS
LTE Band4	20	20050	1	#0	QAM16	21.92	23.86	PASS
LTE Band4	20	20050	1	#Mid	QAM16	22.06	24.00	PASS
LTE Band4	20	20050	1	#Max	QAM16	21.88	23.82	PASS
LTE Band4	20	20050	50	#0	QAM16	21.23	23.17	PASS
LTE Band4	20	20050	50	#Mid	QAM16	21.23	23.17	PASS
LTE Band4	20	20050	50	#Max	QAM16	21.32	23.26	PASS
LTE Band4	20	20050	100	#0	QAM16	21.36	23.30	PASS
LTE Band4	20	20175	1	#0	QPSK	23.20	25.14	PASS
LTE Band4	20	20175	1	#Mid	QPSK	23.07	25.01	PASS
LTE Band4	20	20175	1	#Max	QPSK	23.07	25.01	PASS
LTE Band4	20	20175	50	#0	QPSK	22.00	23.94	PASS
LTE Band4	20	20175	50	#Mid	QPSK	21.96	23.90	PASS
LTE Band4	20	20175	50	#Max	QPSK	21.97	23.91	PASS
LTE Band4	20	20175	100	#0	QPSK	22.10	24.04	PASS
LTE Band4	20	20175	1	#0	QAM16	21.71	23.65	PASS
LTE Band4	20	20175	1	#Mid	QAM16	21.73	23.67	PASS
LTE Band4	20	20175	1	#Max	QAM16	21.78	23.72	PASS
LTE Band4	20	20175	50	#0	QAM16	21.09	23.03	PASS
LTE Band4	20	20175	50	#Mid	QAM16	20.93	22.87	PASS
LTE Band4	20	20175	50	#Max	QAM16	21.14	23.08	PASS
LTE Band4	20	20175	100	#0	QAM16	21.18	23.12	PASS
LTE Band4	20	20300	1	#0	QPSK	23.09	25.03	PASS
LTE Band4	20	20300	1	#Mid	QPSK	23.13	25.07	PASS
LTE Band4	20	20300	1	#Max	QPSK	22.98	24.92	PASS
LTE Band4	20	20300	50	#0	QPSK	22.20	24.14	PASS
LTE Band4	20	20300	50	#Mid	QPSK	22.21	24.15	PASS
LTE Band4	20	20300	50	#Max	QPSK	22.22	24.16	PASS
LTE Band4	20	20300	100	#0	QPSK	22.26	24.20	PASS
LTE Band4	20	20300	1	#0	QAM16	21.97	23.91	PASS
LTE Band4	20	20300	1	#Mid	QAM16	22.24	24.18	PASS
LTE Band4	20	20300	1	#Max	QAM16	22.05	23.99	PASS
LTE Band4	20	20300	50	#0	QAM16	21.22	23.16	PASS
LTE Band4	20	20300	50	#Mid	QAM16	21.23	23.17	PASS
LTE Band4	20	20300	50	#Max	QAM16	21.25	23.19	PASS
LTE Band4	20	20300	100	#0	QAM16	21.25	23.19	PASS



Band	Bandwidth (MHz)	UL Channel	RB Size	RB Position	Modulation	Power (dBm)	EIRP (dBm)	Verdict
LTE Band7	5	20775	1	#0	QPSK	22.90	25.34	PASS
LTE Band7	5	20775	1	#Mid	QPSK	22.99	25.43	PASS
LTE Band7	5	20775	1	#Max	QPSK	23.05	25.49	PASS
LTE Band7	5	20775	12	#0	QPSK	22.27	24.71	PASS
LTE Band7	5	20775	12	#Mid	QPSK	22.27	24.71	PASS
LTE Band7	5	20775	12	#Max	QPSK	22.30	24.74	PASS
LTE Band7	5	20775	25	#0	QPSK	22.29	24.73	PASS
LTE Band7	5	20775	1	#0	QAM16	21.90	24.34	PASS
LTE Band7	5	20775	1	#Mid	QAM16	21.95	24.39	PASS
LTE Band7	5	20775	1	#Max	QAM16	22.15	24.59	PASS
LTE Band7	5	20775	12	#0	QAM16	21.05	23.49	PASS
LTE Band7	5	20775	12	#Mid	QAM16	21.11	23.55	PASS
LTE Band7	5	20775	12	#Max	QAM16	21.14	23.58	PASS
LTE Band7	5	20775	25	#0	QAM16	21.17	23.61	PASS
LTE Band7	5	21100	1	#0	QPSK	23.17	25.61	PASS
LTE Band7	5	21100	1	#Mid	QPSK	23.22	25.66	PASS
LTE Band7	5	21100	1	#Max	QPSK	23.27	25.71	PASS
LTE Band7	5	21100	12	#0	QPSK	22.17	24.61	PASS
LTE Band7	5	21100	12	#Mid	QPSK	22.18	24.62	PASS
LTE Band7	5	21100	12	#Max	QPSK	22.32	24.76	PASS
LTE Band7	5	21100	25	#0	QPSK	22.29	24.73	PASS
LTE Band7	5	21100	1	#0	QAM16	22.21	24.65	PASS
LTE Band7	5	21100	1	#Mid	QAM16	22.11	24.55	PASS
LTE Band7	5	21100	1	#Max	QAM16	22.16	24.60	PASS
LTE Band7	5	21100	12	#0	QAM16	21.10	23.54	PASS
LTE Band7	5	21100	12	#Mid	QAM16	21.10	23.54	PASS
LTE Band7	5	21100	12	#Max	QAM16	21.14	23.58	PASS
LTE Band7	5	21100	25	#0	QAM16	21.16	23.60	PASS
LTE Band7	5	21425	1	#0	QPSK	23.09	25.53	PASS
LTE Band7	5	21425	1	#Mid	QPSK	22.90	25.34	PASS
LTE Band7	5	21425	1	#Max	QPSK	23.07	25.51	PASS
LTE Band7	5	21425	12	#0	QPSK	22.13	24.57	PASS
LTE Band7	5	21425	12	#Mid	QPSK	22.16	24.60	PASS
LTE Band7	5	21425	12	#Max	QPSK	22.06	24.50	PASS
LTE Band7	5	21425	25	#0	QPSK	22.09	24.53	PASS
LTE Band7	5	21425	1	#0	QAM16	22.29	24.73	PASS
LTE Band7	5	21425	1	#Mid	QAM16	22.08	24.52	PASS
LTE Band7	5	21425	1	#Max	QAM16	22.35	24.79	PASS
LTE Band7	5	21425	12	#0	QAM16	20.88	23.32	PASS
LTE Band7	5	21425	12	#Mid	QAM16	20.79	23.23	PASS



LTE Band7	5	21425	12	#Max	QAM16	20.81	23.25	PASS
LTE Band7	5	21425	25	#0	QAM16	20.95	23.39	PASS
LTE Band7	10	20800	1	#0	QPSK	23.24	25.68	PASS
LTE Band7	10	20800	1	#Mid	QPSK	23.09	25.53	PASS
LTE Band7	10	20800	1	#Max	QPSK	22.99	25.43	PASS
LTE Band7	10	20800	25	#0	QPSK	22.27	24.71	PASS
LTE Band7	10	20800	25	#Mid	QPSK	22.26	24.70	PASS
LTE Band7	10	20800	25	#Max	QPSK	22.23	24.67	PASS
LTE Band7	10	20800	50	#0	QPSK	22.25	24.69	PASS
LTE Band7	10	20800	1	#0	QAM16	22.10	24.54	PASS
LTE Band7	10	20800	1	#Mid	QAM16	22.34	24.78	PASS
LTE Band7	10	20800	1	#Max	QAM16	22.16	24.60	PASS
LTE Band7	10	20800	25	#0	QAM16	21.01	23.45	PASS
LTE Band7	10	20800	25	#Mid	QAM16	21.01	23.45	PASS
LTE Band7	10	20800	25	#Max	QAM16	21.04	23.48	PASS
LTE Band7	10	20800	50	#0	QAM16	21.14	23.58	PASS
LTE Band7	10	21100	1	#0	QPSK	23.26	25.70	PASS
LTE Band7	10	21100	1	#Mid	QPSK	23.41	25.85	PASS
LTE Band7	10	21100	1	#Max	QPSK	23.22	25.66	PASS
LTE Band7	10	21100	25	#0	QPSK	22.14	24.58	PASS
LTE Band7	10	21100	25	#Mid	QPSK	22.15	24.59	PASS
LTE Band7	10	21100	25	#Max	QPSK	22.26	24.70	PASS
LTE Band7	10	21100	50	#0	QPSK	22.25	24.69	PASS
LTE Band7	10	21100	1	#0	QAM16	22.70	25.14	PASS
LTE Band7	10	21100	1	#Mid	QAM16	23.13	25.57	PASS
LTE Band7	10	21100	1	#Max	QAM16	23.22	25.66	PASS
LTE Band7	10	21100	25	#0	QAM16	21.28	23.72	PASS
LTE Band7	10	21100	25	#Mid	QAM16	21.30	23.74	PASS
LTE Band7	10	21100	25	#Max	QAM16	21.41	23.85	PASS
LTE Band7	10	21100	50	#0	QAM16	21.17	23.61	PASS
LTE Band7	10	21400	1	#0	QPSK	23.27	25.71	PASS
LTE Band7	10	21400	1	#Mid	QPSK	23.28	25.72	PASS
LTE Band7	10	21400	1	#Max	QPSK	23.48	25.92	PASS
LTE Band7	10	21400	25	#0	QPSK	22.25	24.69	PASS
LTE Band7	10	21400	25	#Mid	QPSK	22.29	24.73	PASS
LTE Band7	10	21400	25	#Max	QPSK	22.15	24.59	PASS
LTE Band7	10	21400	50	#0	QPSK	22.15	24.59	PASS
LTE Band7	10	21400	1	#0	QAM16	22.02	24.46	PASS
LTE Band7	10	21400	1	#Mid	QAM16	22.11	24.55	PASS
LTE Band7	10	21400	1	#Max	QAM16	21.60	24.04	PASS
LTE Band7	10	21400	25	#0	QAM16	21.23	23.67	PASS
LTE Band7	10	21400	25	#Mid	QAM16	21.26	23.70	PASS
LTE Band7	10	21400	25	#Max	QAM16	21.33	23.77	PASS



LTE Band7	10	21400	50	#0	QAM16	21.19	23.63	PASS
LTE Band7	15	20825	1	#0	QPSK	23.29	25.73	PASS
LTE Band7	15	20825	1	#Mid	QPSK	23.17	25.61	PASS
LTE Band7	15	20825	1	#Max	QPSK	23.06	25.50	PASS
LTE Band7	15	20825	36	#0	QPSK	22.26	24.70	PASS
LTE Band7	15	20825	36	#Mid	QPSK	22.25	24.69	PASS
LTE Band7	15	20825	36	#Max	QPSK	22.26	24.70	PASS
LTE Band7	15	20825	75	#0	QPSK	22.20	24.64	PASS
LTE Band7	15	20825	1	#0	QAM16	22.28	24.72	PASS
LTE Band7	15	20825	1	#Mid	QAM16	22.25	24.69	PASS
LTE Band7	15	20825	1	#Max	QAM16	22.16	24.60	PASS
LTE Band7	15	20825	36	#0	QAM16	21.21	23.65	PASS
LTE Band7	15	20825	36	#Mid	QAM16	21.21	23.65	PASS
LTE Band7	15	20825	36	#Max	QAM16	21.33	23.77	PASS
LTE Band7	15	20825	75	#0	QAM16	21.28	23.72	PASS
LTE Band7	15	21100	1	#0	QPSK	23.07	25.51	PASS
LTE Band7	15	21100	1	#Mid	QPSK	22.88	25.32	PASS
LTE Band7	15	21100	1	#Max	QPSK	22.87	25.31	PASS
LTE Band7	15	21100	36	#0	QPSK	22.14	24.58	PASS
LTE Band7	15	21100	36	#Mid	QPSK	22.15	24.59	PASS
LTE Band7	15	21100	36	#Max	QPSK	22.27	24.71	PASS
LTE Band7	15	21100	75	#0	QPSK	22.24	24.68	PASS
LTE Band7	15	21100	1	#0	QAM16	22.74	25.18	PASS
LTE Band7	15	21100	1	#Mid	QAM16	22.58	25.02	PASS
LTE Band7	15	21100	1	#Max	QAM16	22.58	25.02	PASS
LTE Band7	15	21100	36	#0	QAM16	21.09	23.53	PASS
LTE Band7	15	21100	36	#Mid	QAM16	21.08	23.52	PASS
LTE Band7	15	21100	36	#Max	QAM16	21.22	23.66	PASS
LTE Band7	15	21100	75	#0	QAM16	21.20	23.64	PASS
LTE Band7	15	21375	1	#0	QPSK	22.98	25.42	PASS
LTE Band7	15	21375	1	#Mid	QPSK	22.91	25.35	PASS
LTE Band7	15	21375	1	#Max	QPSK	22.95	25.39	PASS
LTE Band7	15	21375	36	#0	QPSK	22.12	24.56	PASS
LTE Band7	15	21375	36	#Mid	QPSK	22.14	24.58	PASS
LTE Band7	15	21375	36	#Max	QPSK	22.03	24.47	PASS
LTE Band7	15	21375	75	#0	QPSK	22.02	24.46	PASS
LTE Band7	15	21375	1	#0	QAM16	21.84	24.28	PASS
LTE Band7	15	21375	1	#Mid	QAM16	21.85	24.29	PASS
LTE Band7	15	21375	1	#Max	QAM16	21.67	24.11	PASS
LTE Band7	15	21375	36	#0	QAM16	20.80	23.24	PASS
LTE Band7	15	21375	36	#Mid	QAM16	20.83	23.27	PASS
LTE Band7	15	21375	36	#Max	QAM16	20.85	23.29	PASS
LTE Band7	15	21375	75	#0	QAM16	20.92	23.36	PASS



LTE Band7	20	20850	1	#0	QPSK	23.16	25.60	PASS
LTE Band7	20	20850	1	#Mid	QPSK	23.15	25.59	PASS
LTE Band7	20	20850	1	#Max	QPSK	22.93	25.37	PASS
LTE Band7	20	20850	50	#0	QPSK	22.18	24.62	PASS
LTE Band7	20	20850	50	#Mid	QPSK	22.17	24.61	PASS
LTE Band7	20	20850	50	#Max	QPSK	22.13	24.57	PASS
LTE Band7	20	20850	100	#0	QPSK	22.11	24.55	PASS
LTE Band7	20	20850	1	#0	QAM16	22.28	24.72	PASS
LTE Band7	20	20850	1	#Mid	QAM16	22.47	24.91	PASS
LTE Band7	20	20850	1	#Max	QAM16	22.12	24.56	PASS
LTE Band7	20	20850	50	#0	QAM16	21.31	23.75	PASS
LTE Band7	20	20850	50	#Mid	QAM16	21.31	23.75	PASS
LTE Band7	20	20850	50	#Max	QAM16	21.18	23.62	PASS
LTE Band7	20	20850	100	#0	QAM16	21.15	23.59	PASS
LTE Band7	20	21100	1	#0	QPSK	22.99	25.43	PASS
LTE Band7	20	21100	1	#Mid	QPSK	23.44	25.88	PASS
LTE Band7	20	21100	1	#Max	QPSK	23.23	25.67	PASS
LTE Band7	20	21100	50	#0	QPSK	22.04	24.48	PASS
LTE Band7	20	21100	50	#Mid	QPSK	22.05	24.49	PASS
LTE Band7	20	21100	50	#Max	QPSK	22.18	24.62	PASS
LTE Band7	20	21100	100	#0	QPSK	22.15	24.59	PASS
LTE Band7	20	21100	1	#0	QAM16	21.74	24.18	PASS
LTE Band7	20	21100	1	#Mid	QAM16	21.68	24.12	PASS
LTE Band7	20	21100	1	#Max	QAM16	21.68	24.12	PASS
LTE Band7	20	21100	50	#0	QAM16	20.94	23.38	PASS
LTE Band7	20	21100	50	#Mid	QAM16	20.95	23.39	PASS
LTE Band7	20	21100	50	#Max	QAM16	21.19	23.63	PASS
LTE Band7	20	21100	100	#0	QAM16	21.22	23.66	PASS
LTE Band7	20	21350	1	#0	QPSK	22.89	25.33	PASS
LTE Band7	20	21350	1	#Mid	QPSK	23.07	25.51	PASS
LTE Band7	20	21350	1	#Max	QPSK	23.24	25.68	PASS
LTE Band7	20	21350	50	#0	QPSK	22.09	24.53	PASS
LTE Band7	20	21350	50	#Mid	QPSK	22.12	24.56	PASS
LTE Band7	20	21350	50	#Max	QPSK	22.04	24.48	PASS
LTE Band7	20	21350	100	#0	QPSK	22.04	24.48	PASS
LTE Band7	20	21350	1	#0	QAM16	22.21	24.65	PASS
LTE Band7	20	21350	1	#Mid	QAM16	22.11	24.55	PASS
LTE Band7	20	21350	1	#Max	QAM16	22.39	24.83	PASS
LTE Band7	20	21350	50	#0	QAM16	21.05	23.49	PASS
LTE Band7	20	21350	50	#Mid	QAM16	21.09	23.53	PASS
LTE Band7	20	21350	50	#Max	QAM16	21.06	23.50	PASS
LTE Band7	20	21350	100	#0	QAM16	21.02	23.46	PASS

## 5.2 Occupied Bandwidth

### Ambient condition

Temperature	Relative humidity	Pressure
23°C ~25°C	45%~50%	101.5kPa

### Method of Measurement

The EUT was connected to Spectrum Analyzer and Base Station Simulator via power Splitter. The occupied bandwidth is measured using spectrum analyzer.

RBW is set to 30 kHz, VBW is set to 91 kHz for LTE Band 4 (1.4MHz).

RBW is set to 62 kHz, VBW is set to 180 kHz for LTE Band 4 (3MHz).

RBW is set to 100 kHz, VBW is set to 300 kHz for LTE Band 4/7 (5MHz).

RBW is set to 200 kHz, VBW is set to 620kHz for LTE Band 4/7 (10MHz).

RBW is set to 300 kHz, VBW is set to 910kHz for LTE Band 4/7 (15MHz).

RBW is set to 430 kHz, VBW is set to 1.2MHz for LTE Band 4/7 (20MHz).

99% power and -26dBc occupied bandwidths are recorded. Spectrum analyzer plots are included on the following pages.

### Test Setup

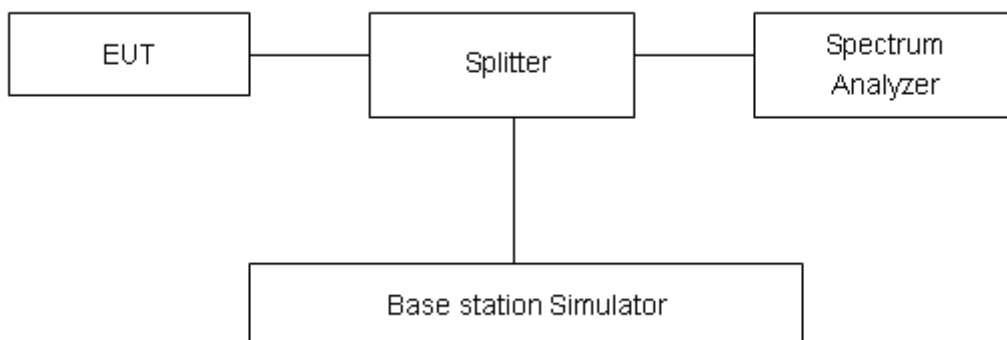

### Limits

No specific occupied bandwidth requirements in part 2.1049.

### Measurement Uncertainty

The assessed measurement uncertainty to ensure 95% confidence level for the normal distribution is with the coverage factor  $k = 2$ ,  $U=624\text{Hz}$ .





## Test Result

LTE Band 4						
RB	Modulation	Bandwidth (MHz)	Channel	Frequency (MHz)	99% Power Bandwidth(MHz)	-26dBc Bandwidth(MHz)
100%	QPSK	1.4	19957	1710.7	1.0971	1.275
			20175	1732.5	1.0913	1.296
			20393	1754.3	1.0949	1.286
		3	19965	1711.5	2.7068	2.983
			20175	1732.5	2.7132	2.972
			20385	1753.5	2.6975	2.966
		5	19975	1712.5	4.5223	5.001
			20175	1732.5	4.5097	4.976
			20375	1752.5	4.4971	4.930
		10	20000	1715	8.9761	9.908
			20175	1732.5	8.9532	9.716
			20350	1750	8.9363	9.787
		15	20025	1717.5	13.444	14.63
			20175	1732.5	13.384	14.54
			20325	1747.5	13.415	14.56
	20	20050	1720	17.866	19.44	
		20175	1732.5	17.907	19.23	
		20300	1745	17.867	19.51	
	16QAM	1.4	19957	1710.7	1.0998	1.289
			20175	1732.5	1.1018	1.293
			20393	1754.3	1.0961	1.278
		3	19965	1711.5	2.6908	3.013
			20175	1732.5	2.7016	2.98
			20385	1753.5	2.7053	3.005
		5	19975	1712.5	4.5391	5.025
			20175	1732.5	4.5229	4.992
			20375	1752.5	4.5034	5.066
		10	20000	1715	8.9448	9.745
			20175	1732.5	8.9739	9.778
			20350	1750	8.9784	9.707
15		20025	1717.5	13.451	14.66	
		20175	1732.5	13.417	14.54	
		20325	1747.5	13.454	14.65	
20	20050	1720	17.891	19.33		
	20175	1732.5	17.883	19.41		
	20300	1745	17.866	19.32		



LTE Band 7						
RB	Modulation	Bandwidth (MHz)	Channel	Frequency (MHz)	99% Power Bandwidth(MHz)	-26dBc Bandwidth(MHz)
100%	QPSK	5	20775	2502.5	4.516	4.992
			21100	2535	4.513	4.946
			21425	2567.5	4.504	4.936
		10	20800	2505	8.979	9.836
			21100	2535	8.963	9.884
			21400	2565	8.972	9.801
		15	20825	2507.5	13.432	14.730
			21100	2535	13.419	14.580
			21375	2562.5	13.441	14.600
		20	20850	2510	17.928	19.210
			21100	2535	17.908	19.360
			21350	2560	17.886	19.490
	16QAM	5	20775	2502.5	4.508	4.961
			21100	2535	4.538	5.011
			21425	2567.5	4.514	4.948
		10	20800	2505	8.966	9.720
			21100	2535	8.974	9.648
			21400	2565	8.981	9.863
		15	20825	2507.5	13.423	14.580
			21100	2535	13.396	14.610
			21375	2562.5	13.404	14.490
		20	20850	2510	17.900	19.300
			21100	2535	17.883	19.380
			21350	2560	17.881	19.330





### LTE Band 4 QPSK 1.4MHz CH-Low

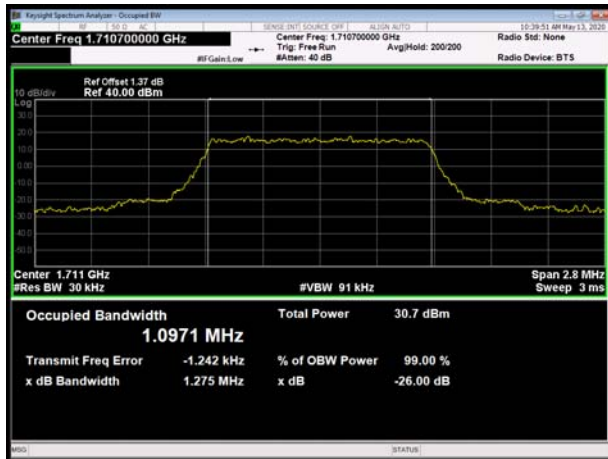

### LTE Band 4 QPSK 3MHz CH-Low

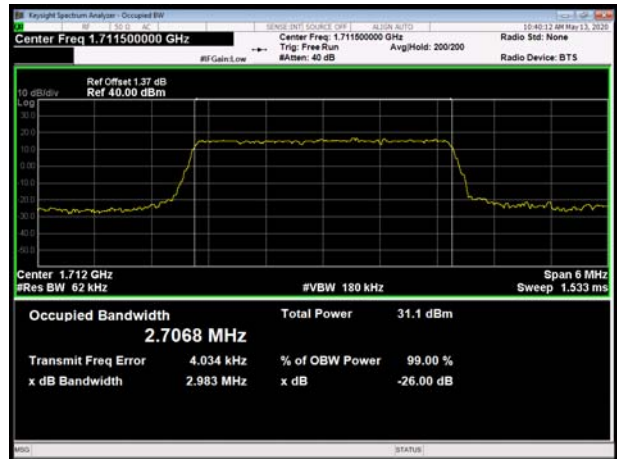

### LTE Band 4 QPSK 1.4MHz CH-Middle

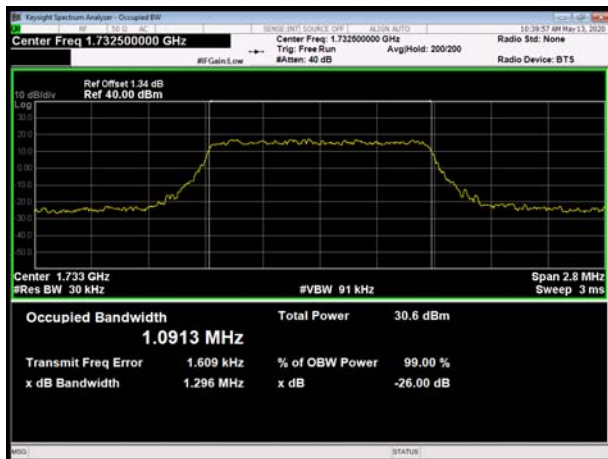

### LTE Band 4 QPSK 3MHz CH-Middle

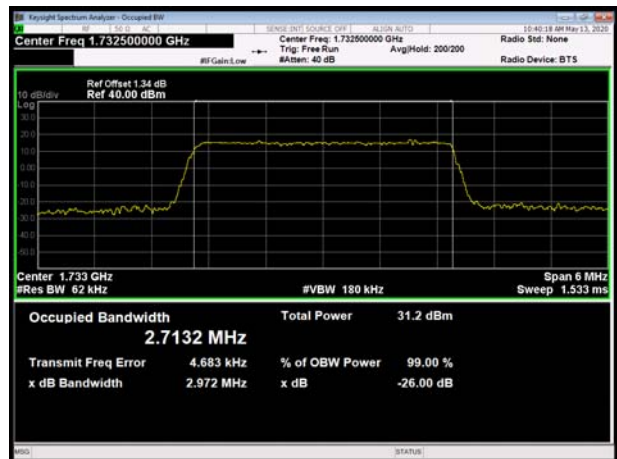

### LTE Band 4 QPSK 1.4MHz CH-High

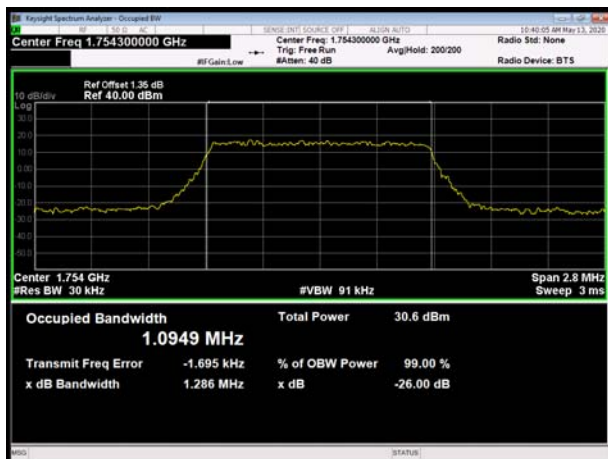

### LTE Band 4 QPSK 3MHz CH-High

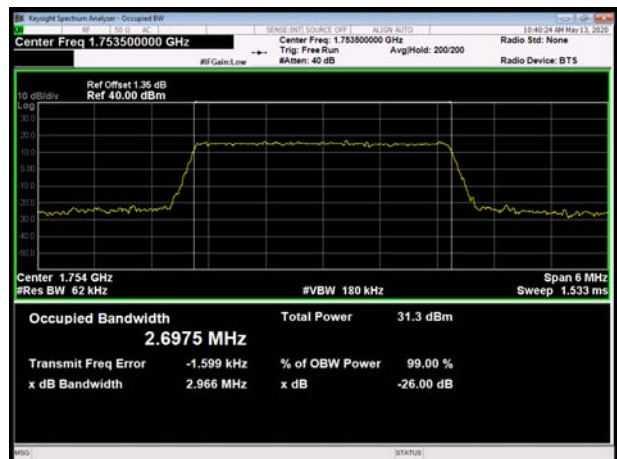



### LTE Band 4 QPSK 5MHz CH-Low

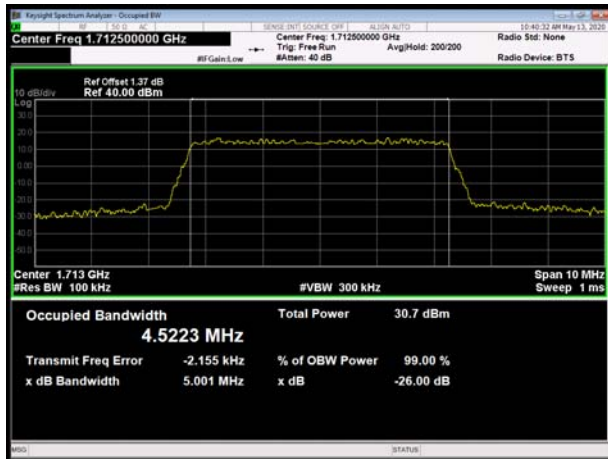

### LTE Band 4 QPSK 10MHz CH-Low

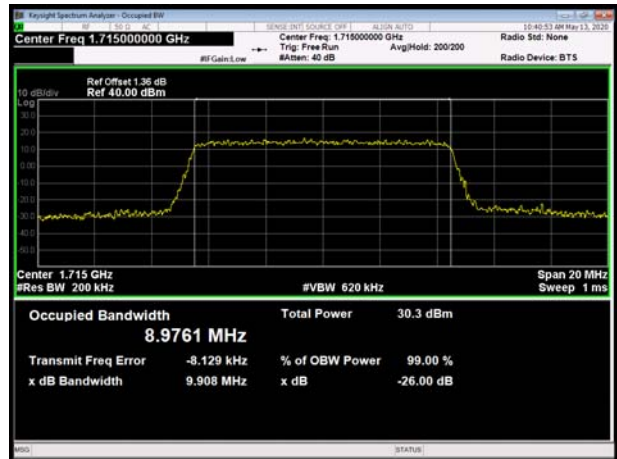

### LTE Band 4 QPSK 5MHz CH-Middle

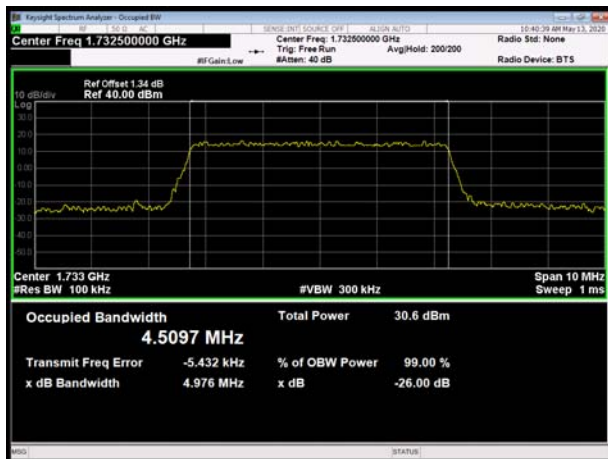

### LTE Band 4 QPSK 10MHz CH-Middle

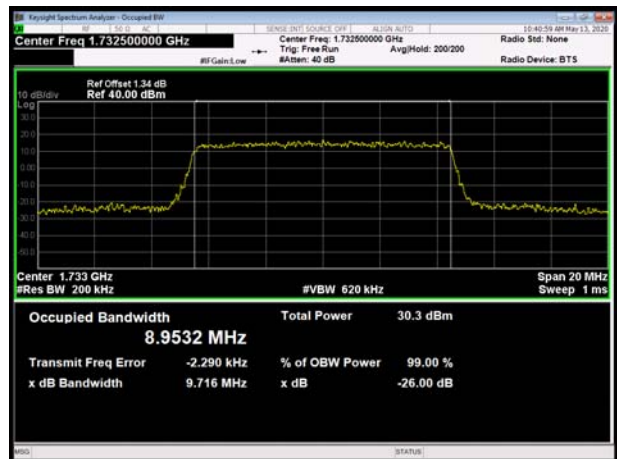

### LTE Band 4 QPSK 5MHz CH-High



### LTE Band 4 QPSK 10MHz CH-High





### LTE Band 4 QPSK 15MHz CH-Low

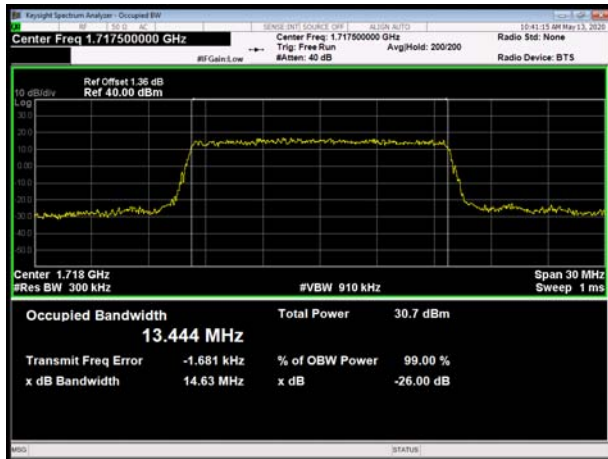

### LTE Band 4 QPSK 20MHz CH-Low

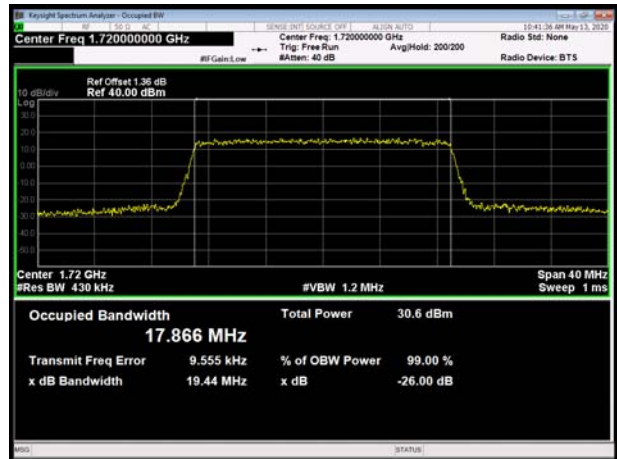

### LTE Band 4 QPSK 15MHz CH-Middle

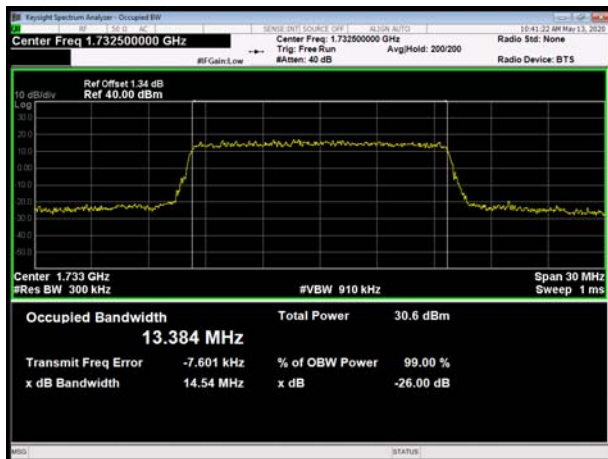

### LTE Band 4 QPSK 20MHz CH-Middle

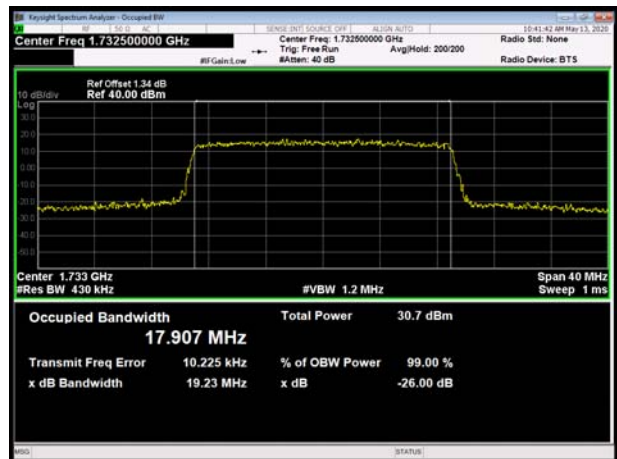

### LTE Band 4 QPSK 15MHz CH-High

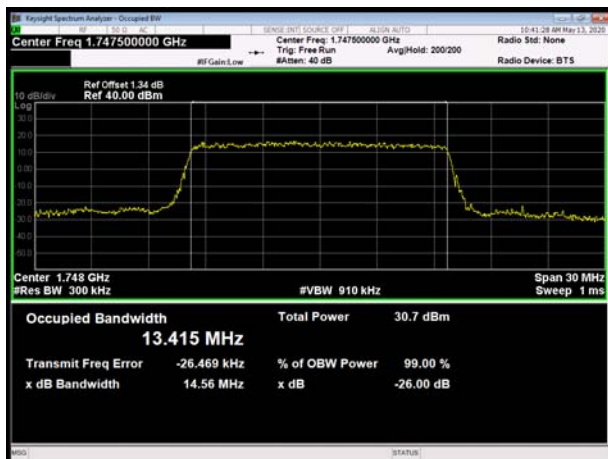

### LTE Band 4 QPSK 20MHz CH-High

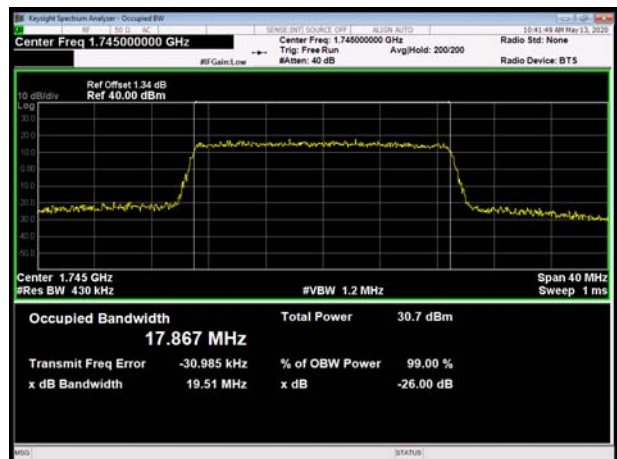



### LTE Band 4 16QAM 1.4MHz CH-Low

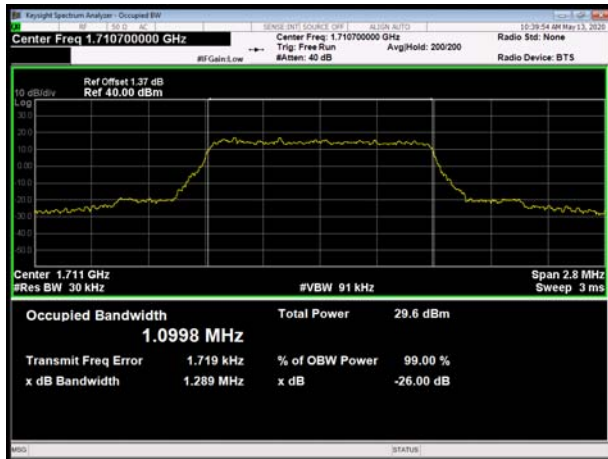

### LTE Band 4 16QAM 3MHz CH-Low

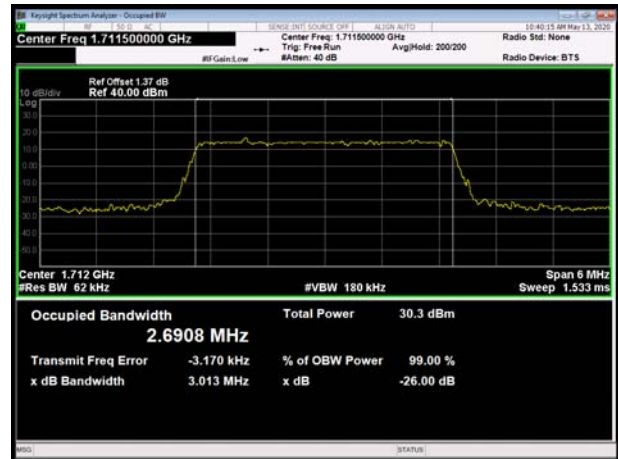

### LTE Band 4 16QAM 1.4MHz CH-Middle

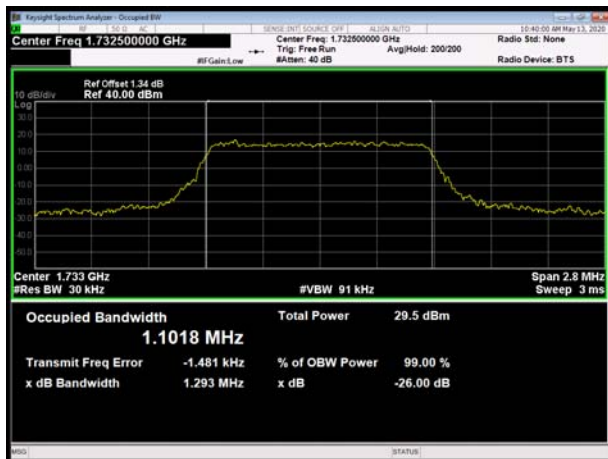

### LTE Band 4 16QAM 3MHz CH-Middle



### LTE Band 4 16QAM 1.4MHz CH-High

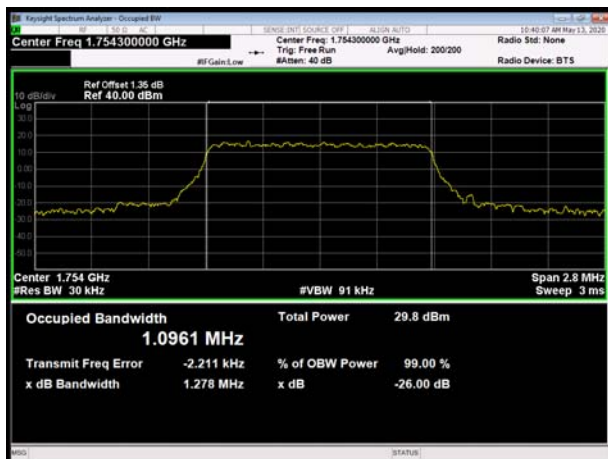

### LTE Band 4 16QAM 3MHz CH-High

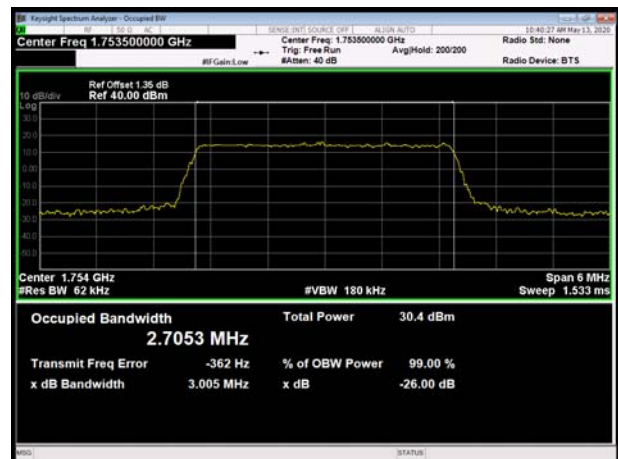



### LTE Band 4 16QAM 5MHz CH-Low

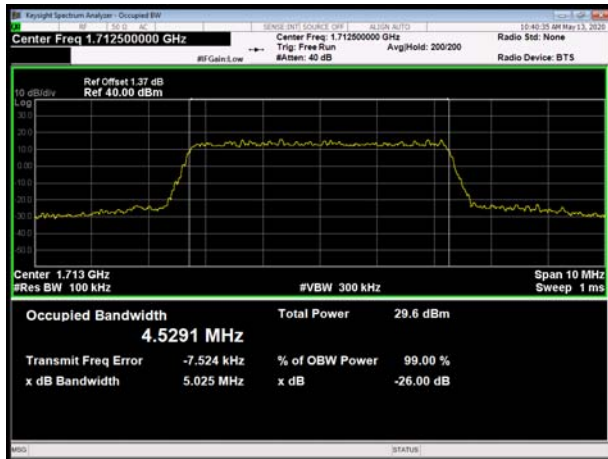

### LTE Band 4 16QAM 10MHz CH-Low

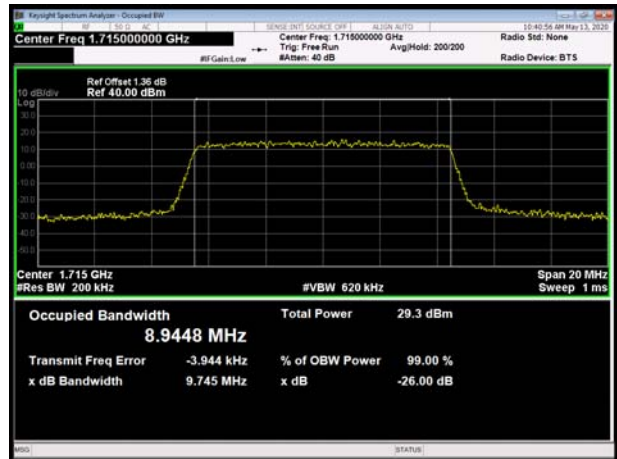

### LTE Band 4 16QAM 5MHz CH-Middle

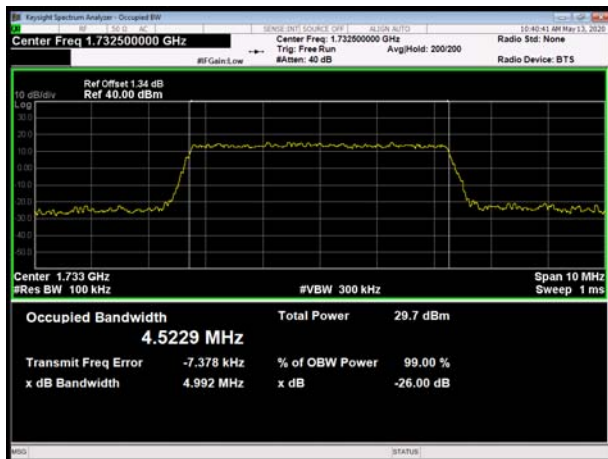

### LTE Band 4 16QAM 10MHz CH-Middle



### LTE Band 4 16QAM 5MHz CH-High

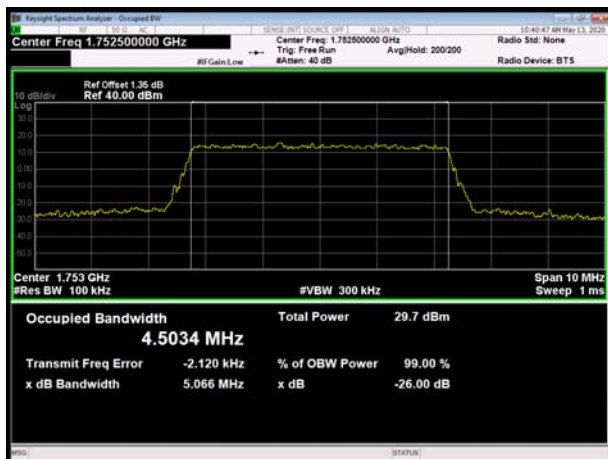

### LTE Band 4 16QAM 10MHz CH-High

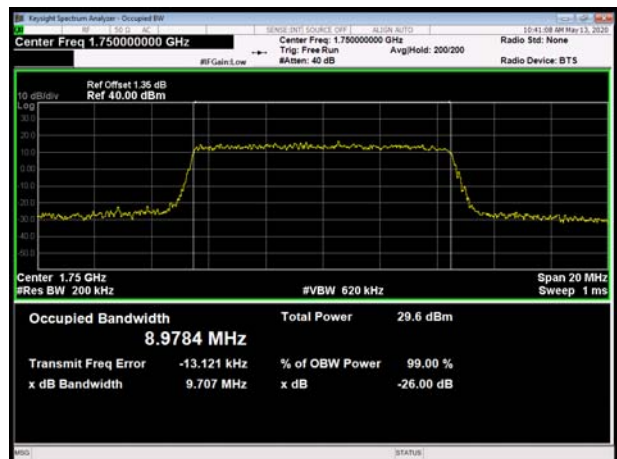





### LTE Band 4 16QAM 15MHz CH-Low

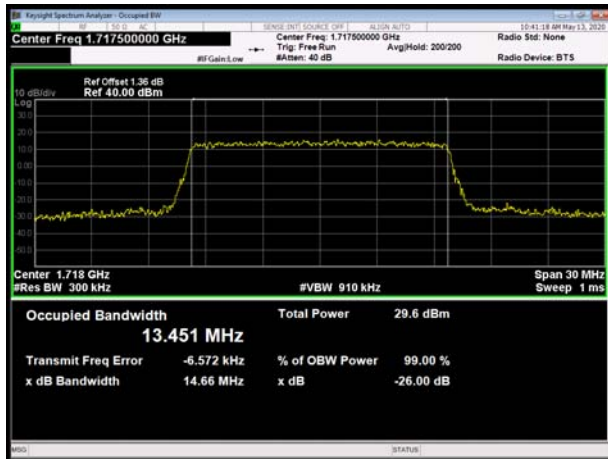

### LTE Band 4 16QAM 20MHz CH-Low

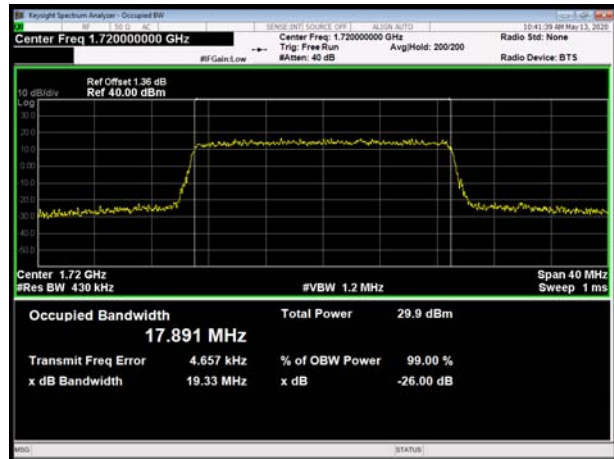

### LTE Band 4 16QAM 15MHz CH-Middle

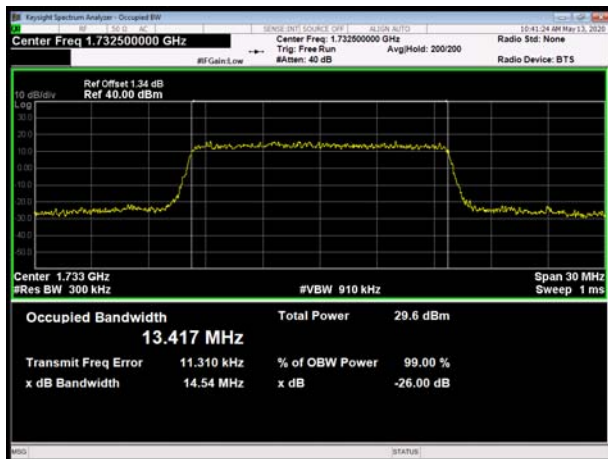

### LTE Band 4 16QAM 20MHz CH-Middle

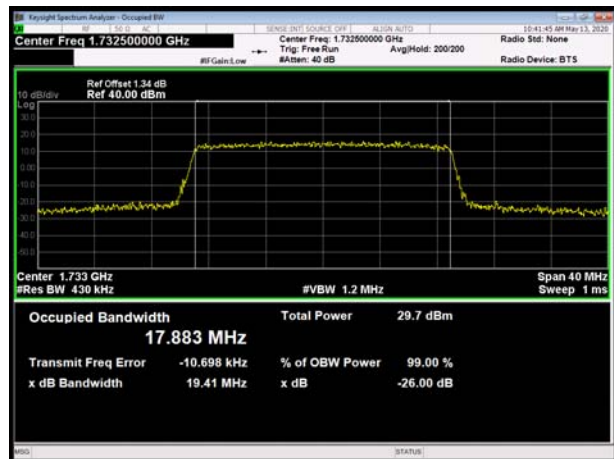

### LTE Band 4 16QAM 15MHz CH-High

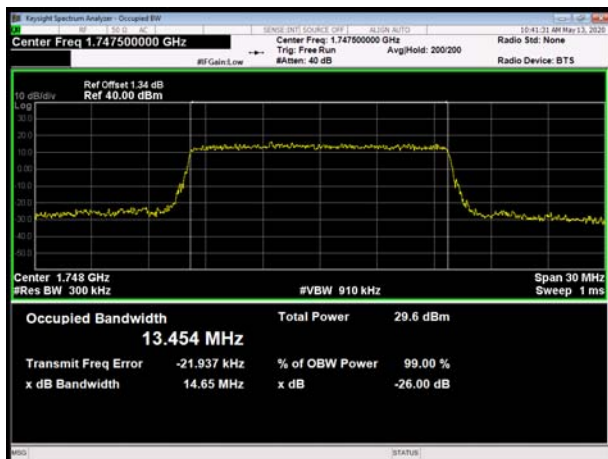

### LTE Band 4 16QAM 20MHz CH-High

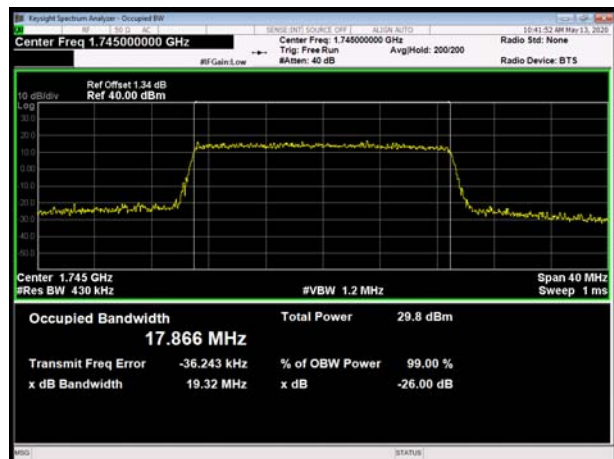



### LTE Band 7 QPSK 5MHz CH-Low

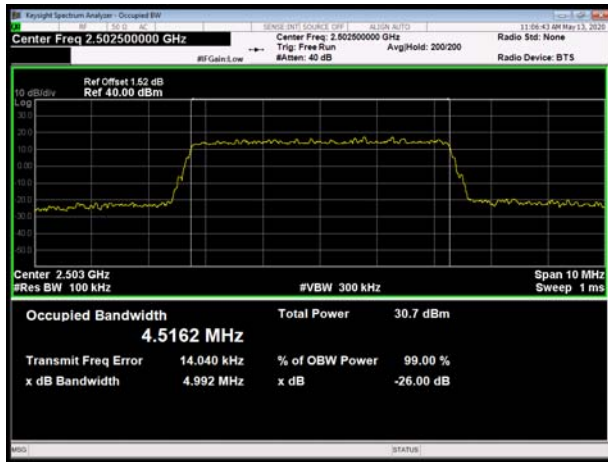

### LTE Band 7 QPSK 10MHz CH-Low

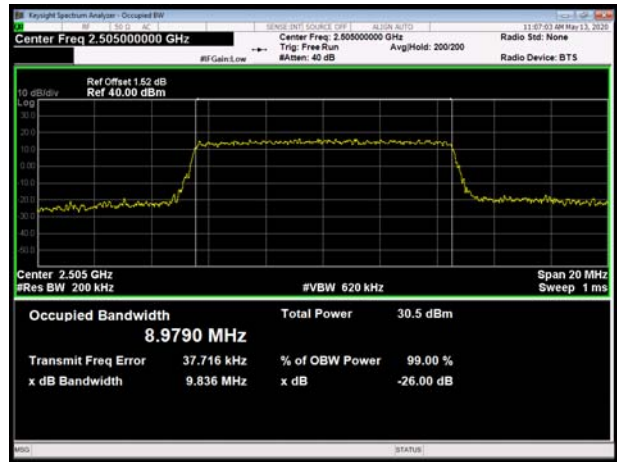

### LTE Band 7 QPSK 5MHz CH-Middle



### LTE Band 7 QPSK 10MHz CH-Middle

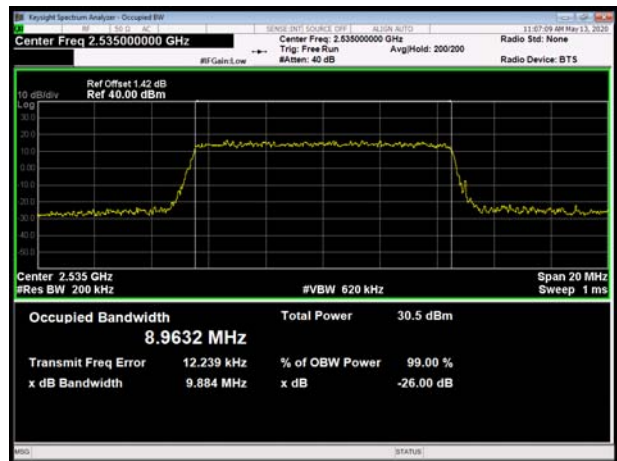

### LTE Band 7 QPSK 5MHz CH-High

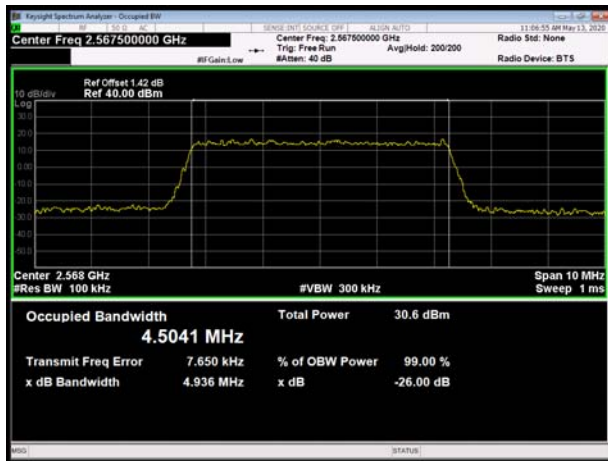

### LTE Band 7 QPSK 10MHz CH-High

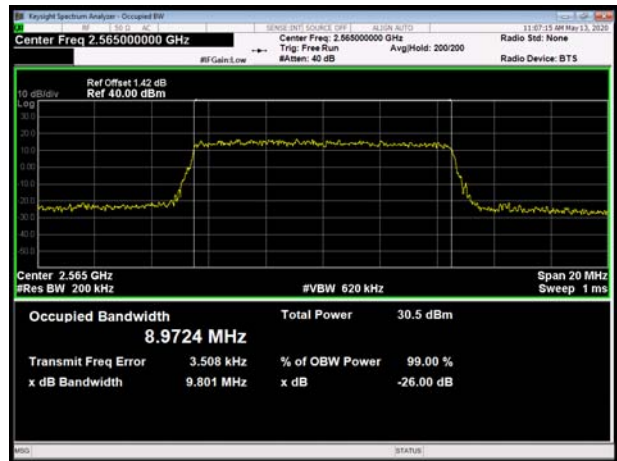



### LTE Band 7 QPSK 15MHz CH-Low

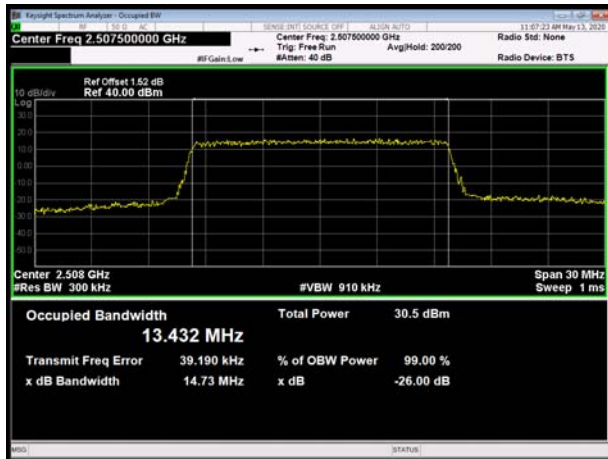

### LTE Band 7 QPSK 20MHz CH-Low

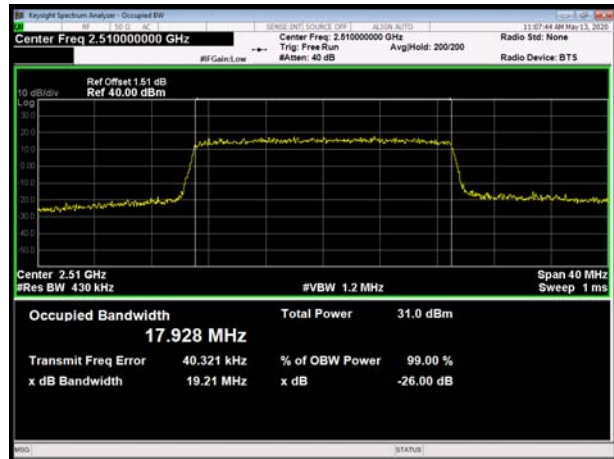

### LTE Band 7 QPSK 15MHz CH-Middle

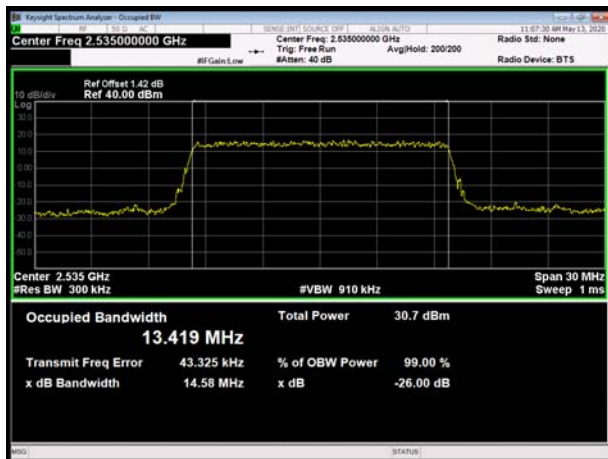

### LTE Band 7 QPSK 20MHz CH-Middle

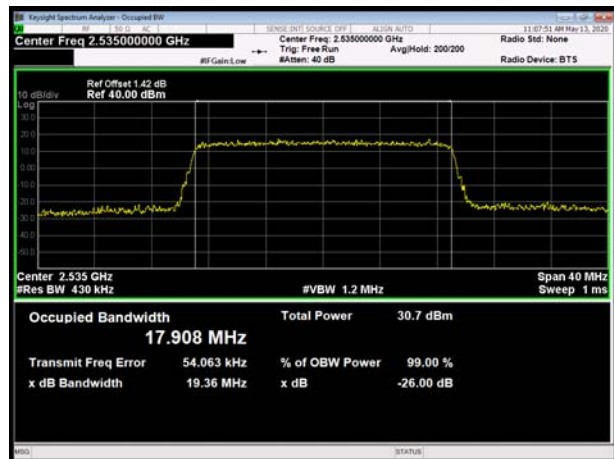

### LTE Band 7 QPSK 15MHz CH-High

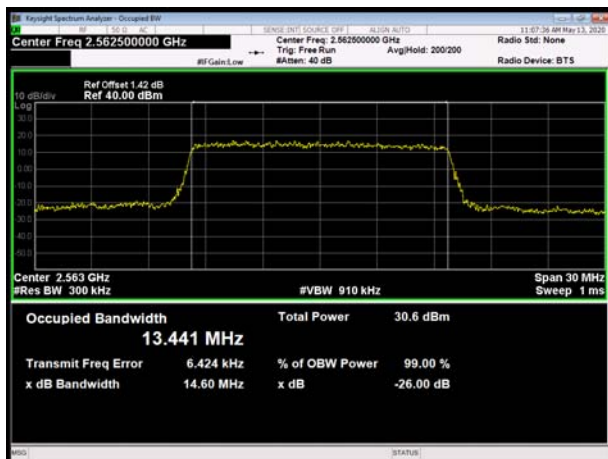

### LTE Band 7 QPSK 20MHz CH-High

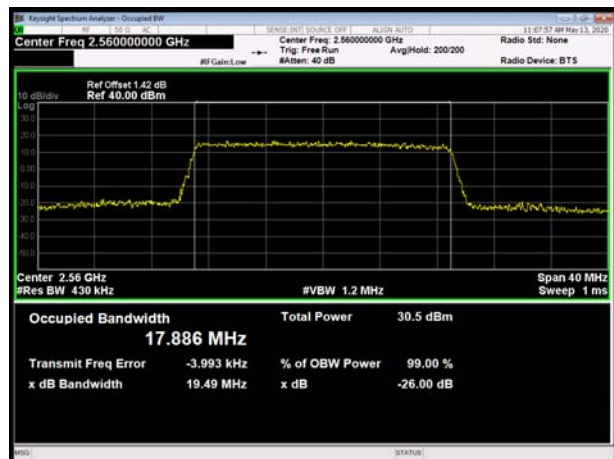





### LTE Band 7 16QAM 5MHz CH-Low

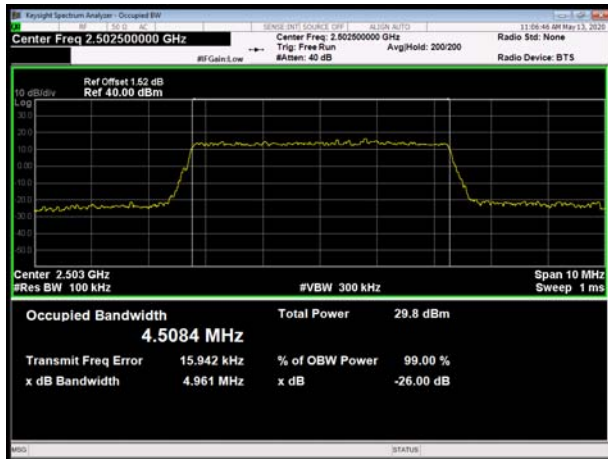

### LTE Band 7 16QAM 10MHz CH-Low

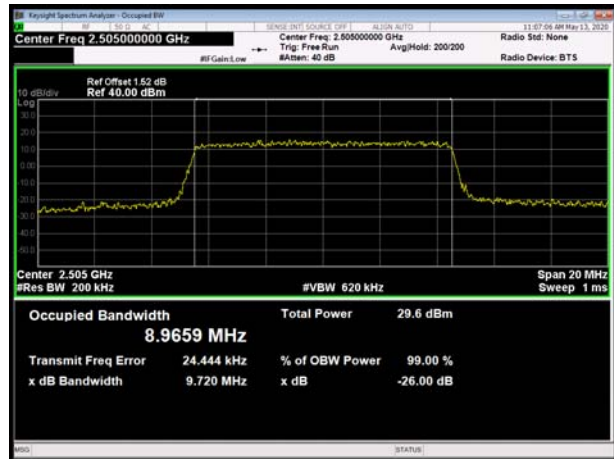

### LTE Band 7 16QAM 5MHz CH-Middle

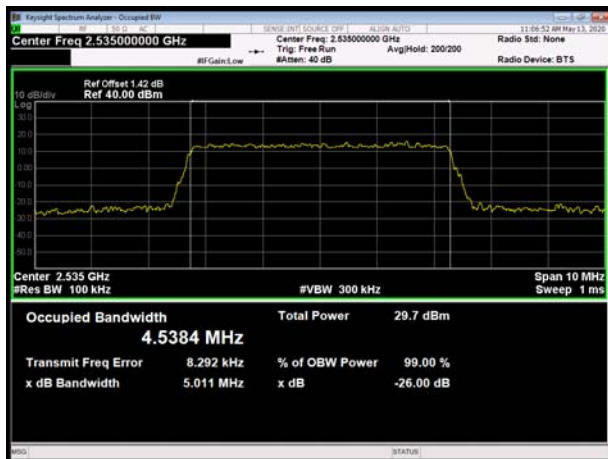

### LTE Band 7 16QAM 10MHz CH-Middle

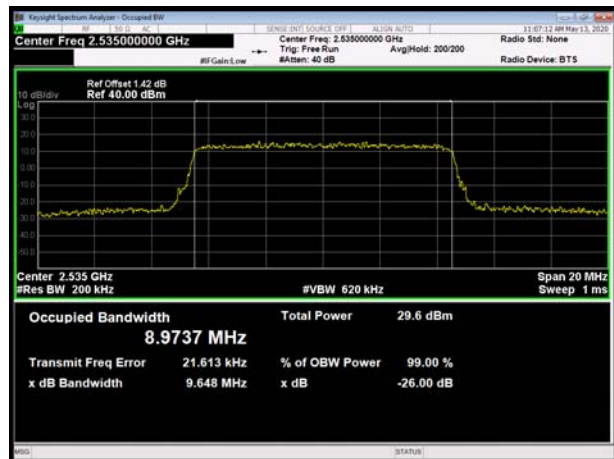

### LTE Band 7 16QAM 5MHz CH-High

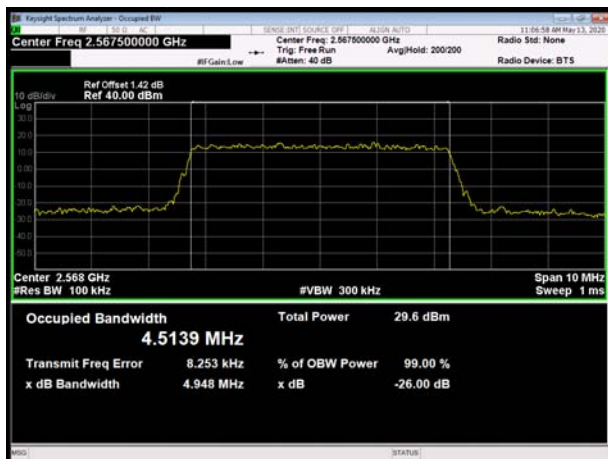

### LTE Band 7 16QAM 10MHz CH-High

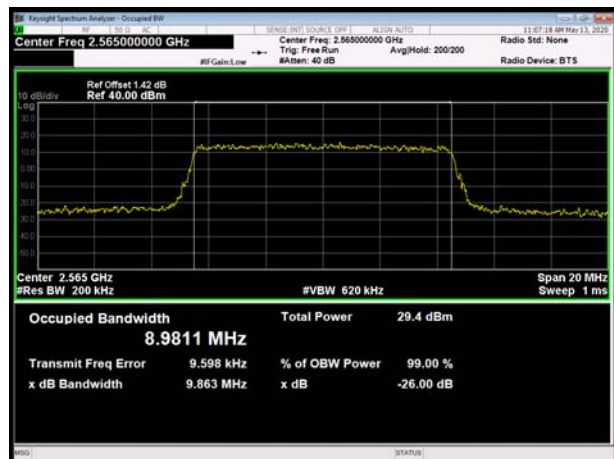



LTE Band 7 16QAM 15MHz CH-Low

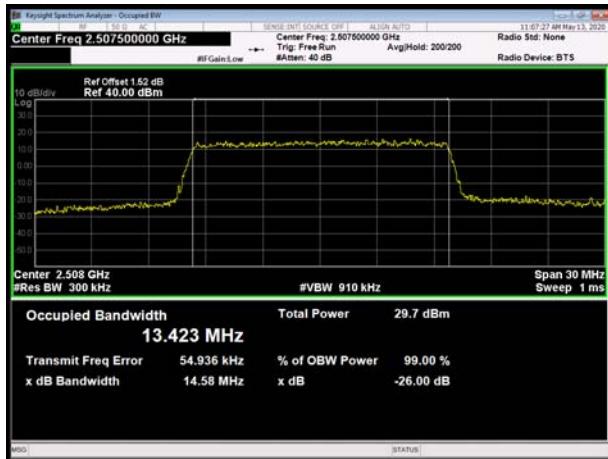

LTE Band 7 16QAM 20MHz CH-Low



LTE Band 7 16QAM 15MHz CH-Middle



LTE Band 7 16QAM 20MHz CH-Middle

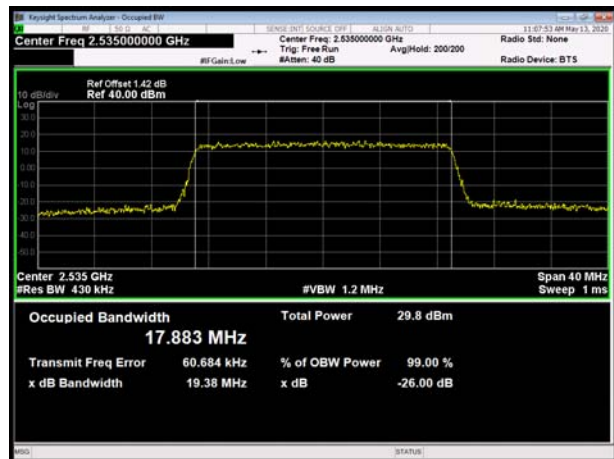

LTE Band 7 16QAM 15MHz CH-High

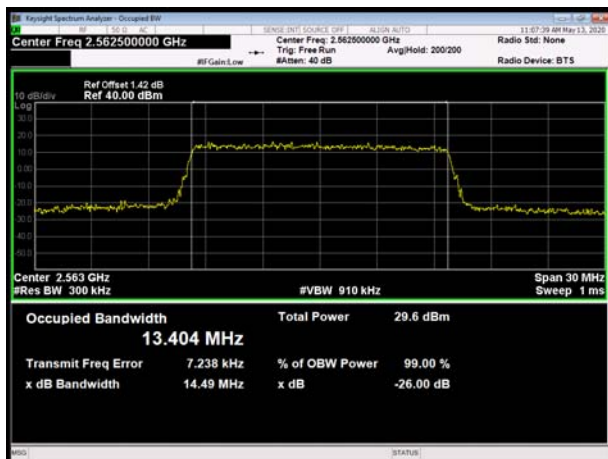

LTE Band 7 16QAM 20MHz CH-High

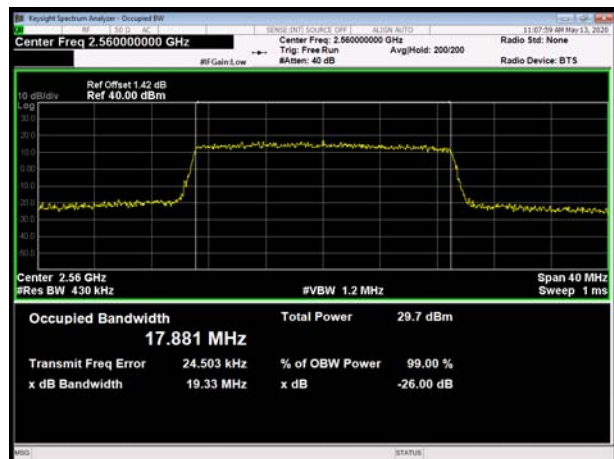

### 5.3 Band Edge Compliance

#### Ambient condition

Temperature	Relative humidity	Pressure
23°C ~25°C	45%~50%	101.5kPa

#### Method of Measurement

The EUT was connected to Spectrum Analyzer and Base Station Simulator via power Splitter. The band edge of the lowest and highest channels were measured.

The testing follows KDB 971168 D01 v03r01 Section 6.0

The EUT was connected to spectrum analyzer and system simulator via a power divider.

The band edges of low and high channels for the highest RF powers were measured.

RBW is set to 15 kHz, VBW is set to 43 kHz for LTE Band 4 (1.4MHz).

RBW is set to 30 kHz, VBW is set to 91 kHz for LTE Band 4 (3MHz).

RBW is set to 51 kHz, VBW is set to 150 kHz for LTE Band 4 (5MHz).

RBW is set to 50 kHz, VBW is set to 200 kHz for LTE Band 7 (5MHz).

RBW is set to 100 kHz, VBW is set to 300kHz for LTE Band 4/7 (10MHz).

RBW is set to 150 kHz, VBW is set to 470 kHz for LTE Band 4 (15MHz).

RBW is set to 200 kHz, VBW is set to 620 kHz for LTE Band 4 (20MHz).

RBW is set to 200 kHz, VBW is set to 1 MHz for LTE Band 7 (15MHz/20MHz).

on spectrum analyzer.

Set spectrum analyzer with RMS detector.

The RF fundamental frequency should be excluded against the limit line in the operating frequency band.

Checked that all the results comply with the emission limit line.

#### Test Setup

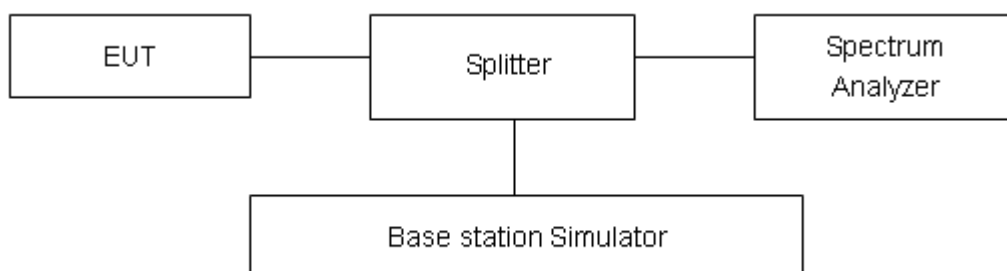

#### Limits

Rule Part 27.53(h) specifies that “ for operations in the 1695-1710 MHz, 1710-1755 MHz, 1755-1780 MHz, 1915-1920 MHz, 1995-2000 MHz, 2000-2020 MHz, 2110-2155 MHz, 2155-2180 MHz, and 2180-2200 bands, the power of any emission outside a licensee's frequency block shall be attenuated below the transmitter power (P) in watts by at least  $43 + 10 \log_{10} (P)$  dB”

Rule Part 27.53(m) (4) specifies that “for BRS and EBS stations. For mobile digital stations, the attenuation factor shall be not less than  $40 + 10 \log (P)$  dB on all frequencies between the channel edge and 5 megahertz from the channel edge,  $43 + 10 \log (P)$  dB on all frequencies between 5 megahertz and X megahertz from the channel edge, and  $55 + 10 \log (P)$  dB on all frequencies more than X megahertz from the channel edge, where X is the greater of 6 megahertz or the actual emission bandwidth as defined in paragraph (m)(4) of this section. In addition, the attenuation factor shall not be less than  $43 + 10 \log (P)$  dB on all frequencies between 2490.5 MHz and 2496 MHz and  $55 + 10 \log (P)$  dB at or below 2490.5 MHz. Mobile Satellite Service licensees operating on frequencies below 2495 MHz may also submit a documented interference complaint against BRS licensees operating on channel BRS Channel 1 on the same terms and conditions as adjacent channel BRS or EBS licensees.

Example:

The limit line is derived from  $43 + 10 \log (P)$  dB below the transmitter power P(Watts)

$$= P(W) - [43 + 10 \log (P)] \text{ (dB)}$$

$$= [30 + 10 \log (P)] \text{ (dBm)} - [43 + 10 \log (P)] \text{ (dB)} = -13 \text{ dBm.}$$

### Measurement Uncertainty

The assessed measurement uncertainty to ensure 95% confidence level for the normal distribution is with the coverage factor  $k = 1.96$ ,  $U = 0.684 \text{ dB}$ .



### Test Result

All the test traces in the plots shows the test results clearly.

LTE Band 4 QPSK 1.4MHz CH-Low, 1 RB

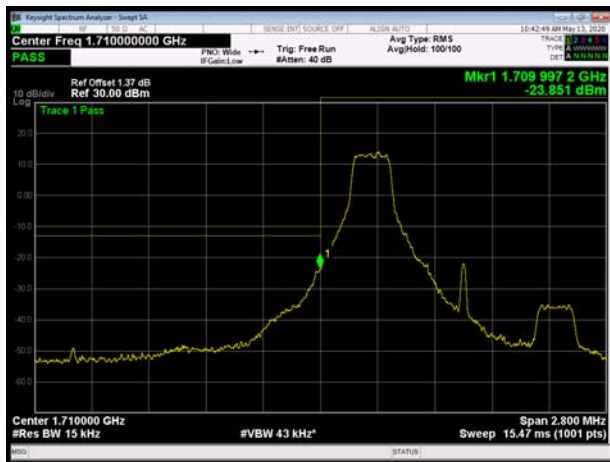

LTE Band 4 QPSK 1.4MHz CH-High, 1 RB

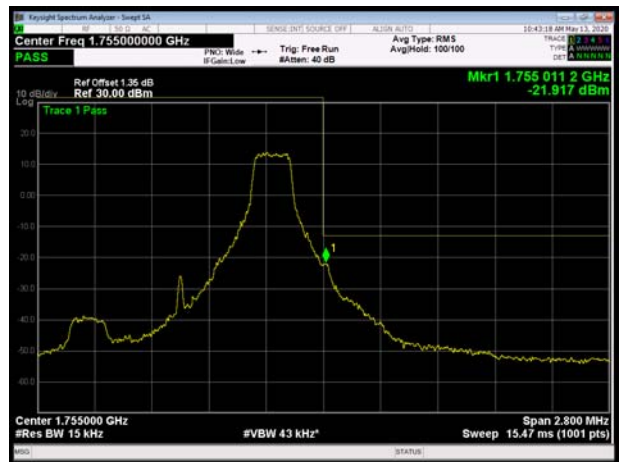

LTE Band 4 QPSK 1.4MHz CH-Low, 100%RB



LTE Band 4 QPSK 1.4MHz CH-High, 100%RB



LTE Band 4 QPSK 3MHz CH-Low, 1 RB

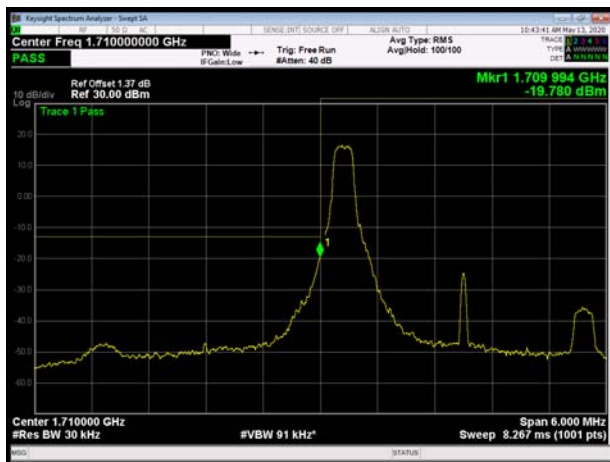

LTE Band 4 QPSK 3MHz CH-High, 1 RB

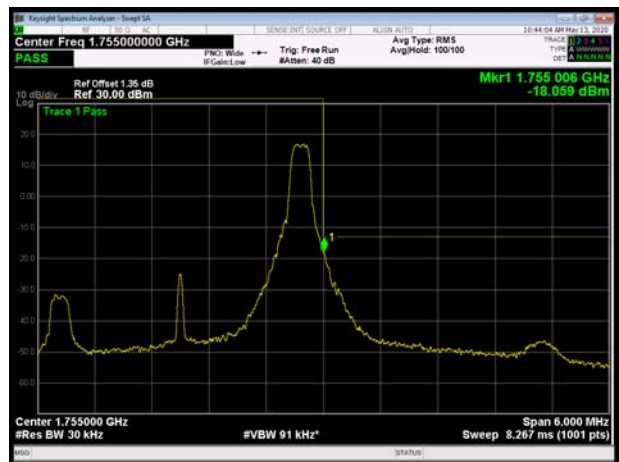



LTE Band 4 QPSK 3MHz CH-Low, 100%RB

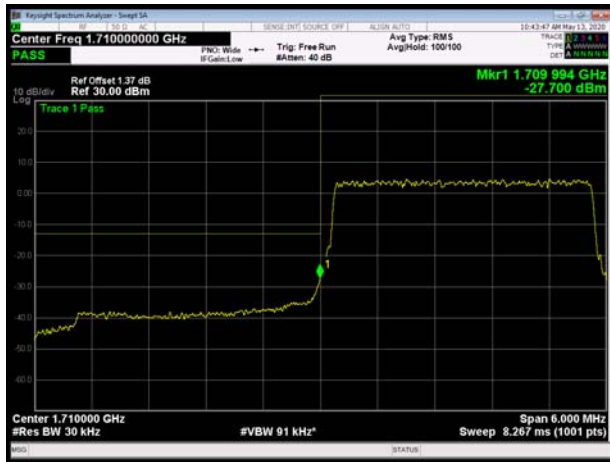

LTE Band 4 QPSK 3MHz CH-High, 100%RB

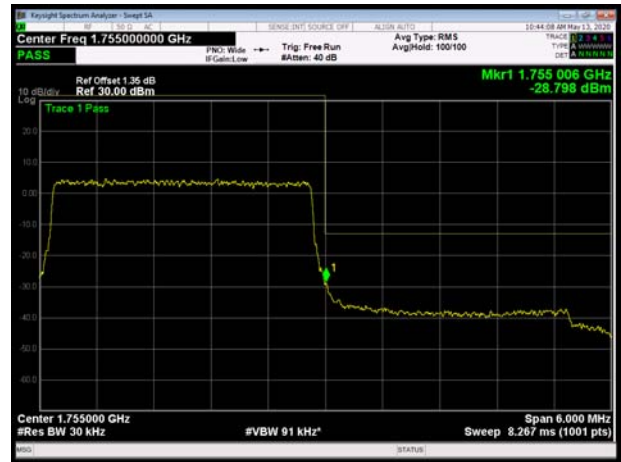

LTE Band 4 QPSK 5MHz CH-Low, 1 RB

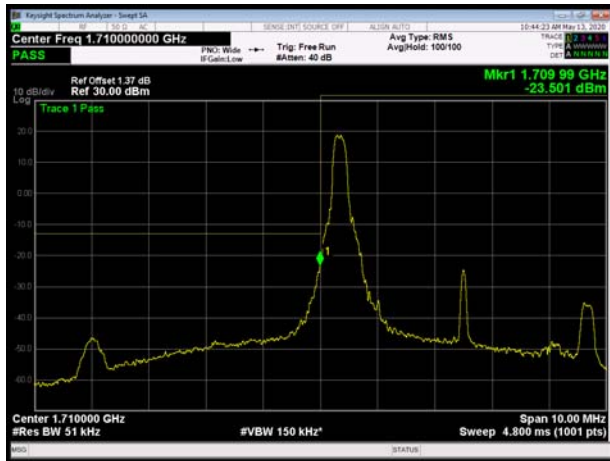

LTE Band 4 QPSK 5MHz CH-High, 1 RB

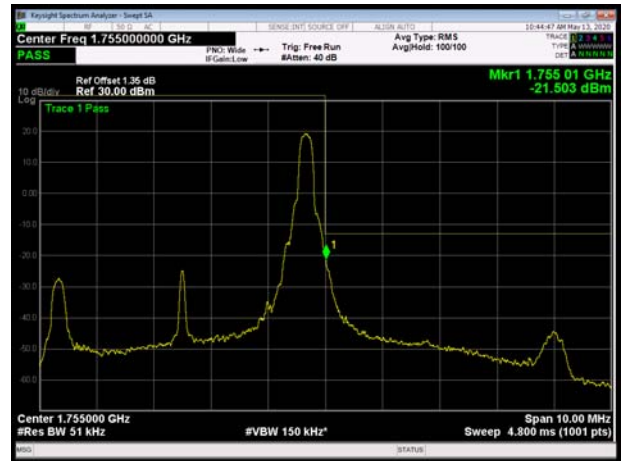

LTE Band 4 QPSK 5MHz CH-Low, 100%RB

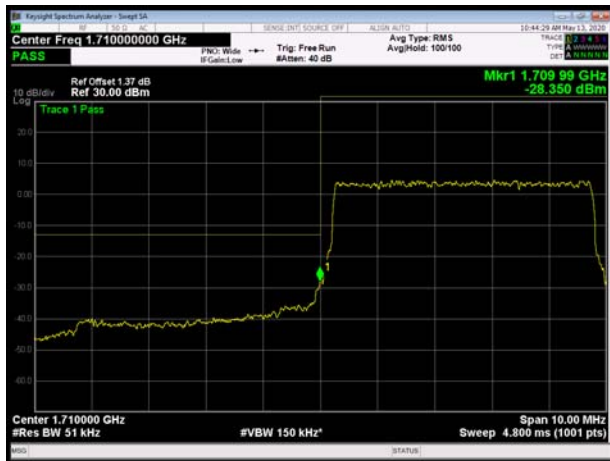

LTE Band 4 QPSK 5MHz CH-High, 100%RB

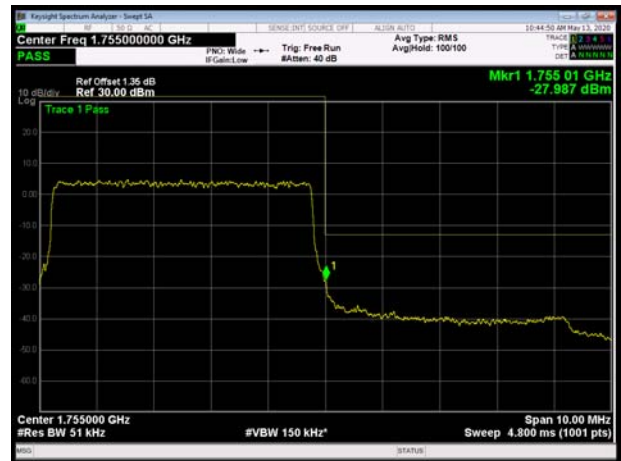





LTE Band 4 QPSK 10MHz CH-Low, 1 RB

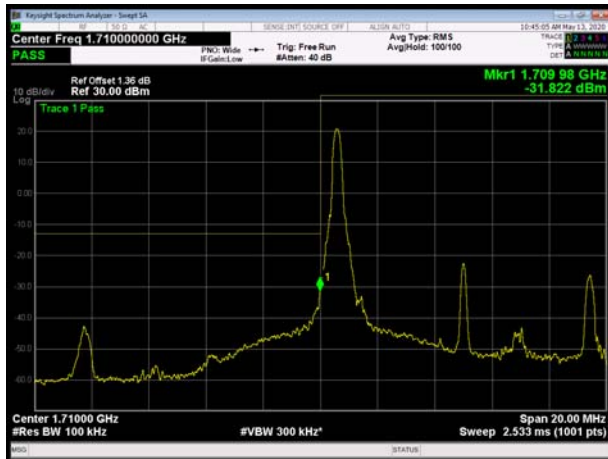

LTE Band 4 QPSK 10MHz CH-High, 1 RB

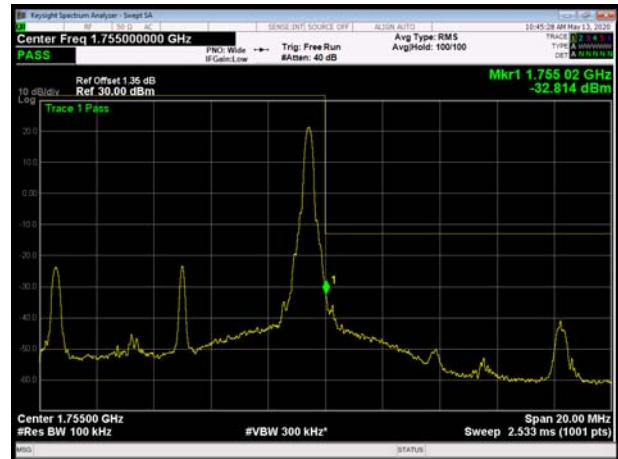

LTE Band 4 QPSK 10MHz CH-Low, 100%RB

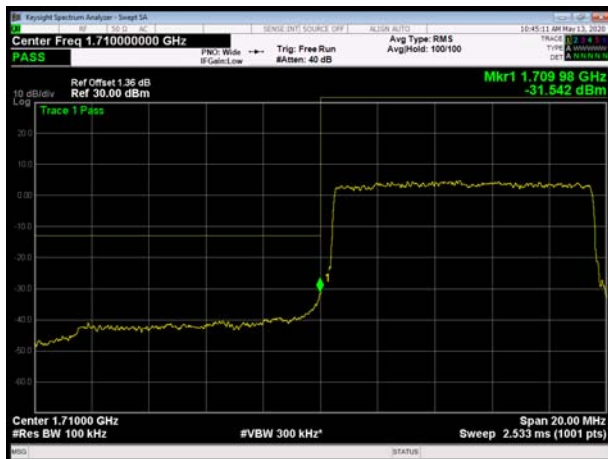

LTE Band 4 QPSK 10MHz CH-High, 100%RB



LTE Band 4 QPSK 15MHz CH-Low, 1 RB

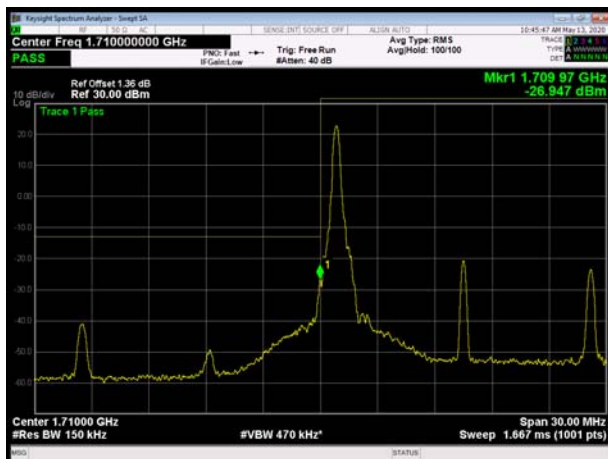

LTE Band 4 QPSK 15MHz CH-High, 1 RB

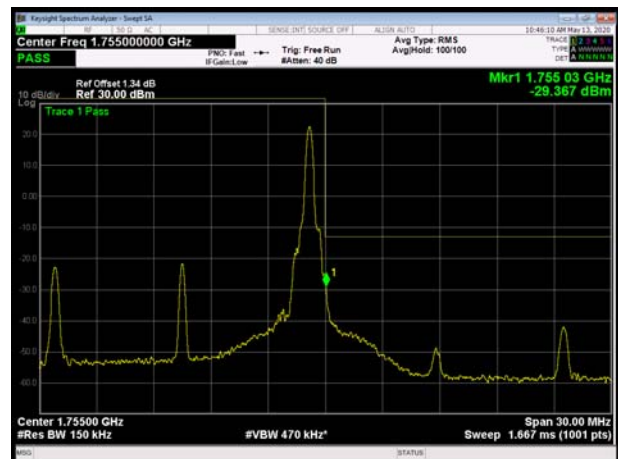



LTE Band 4 QPSK 15MHz CH-Low, 100%RB



LTE Band 4 QPSK 15MHz CH-High, 100%RB



LTE Band 4 QPSK 20MHz CH-Low, 1 RB

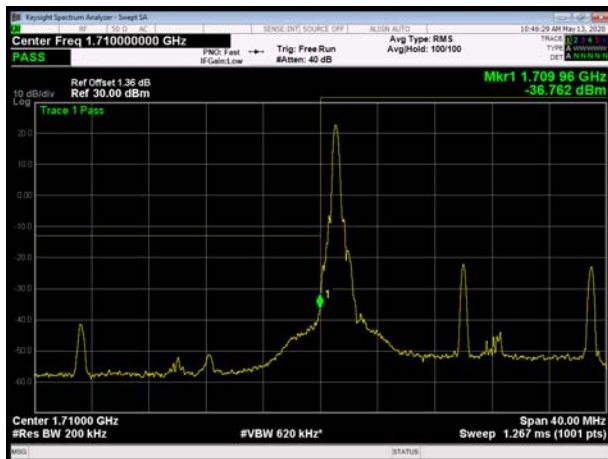

LTE Band 4 QPSK 20MHz CH-High, 1 RB

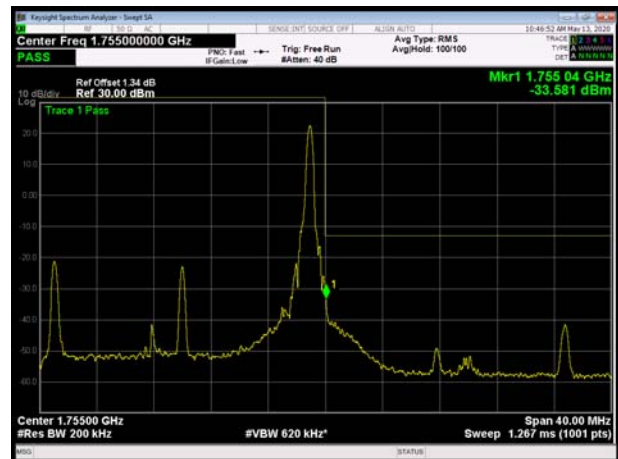

LTE Band 4 QPSK 20MHz CH-Low, 100%RB

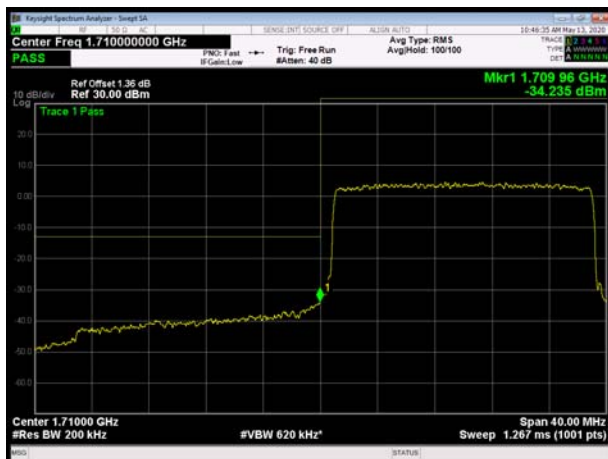

LTE Band 4 QPSK 20MHz CH-High, 100%RB

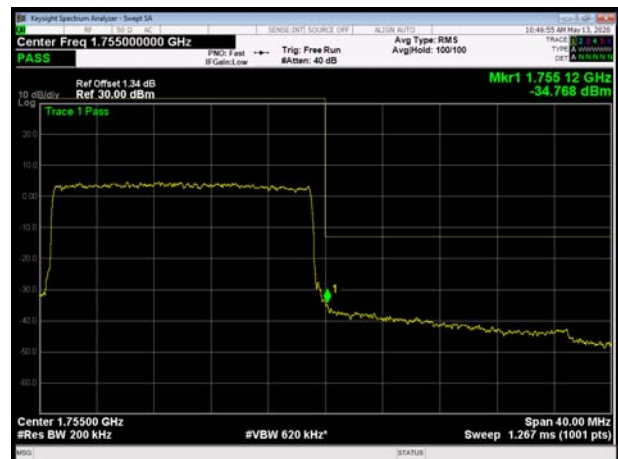





LTE Band 4 16QAM 1.4MHz CH-Low, 1 RB

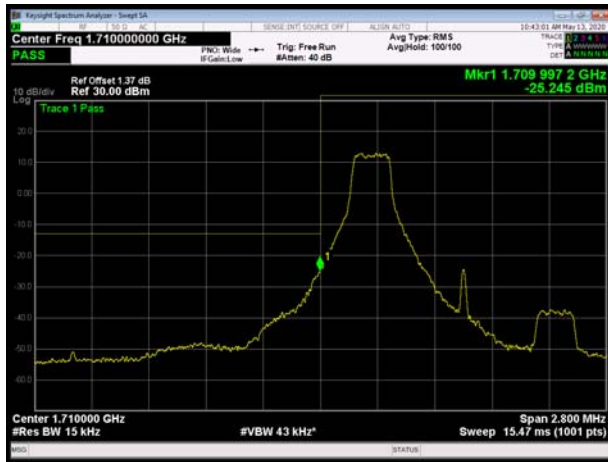

LTE Band 4 16QAM 1.4MHz CH-High, 1 RB

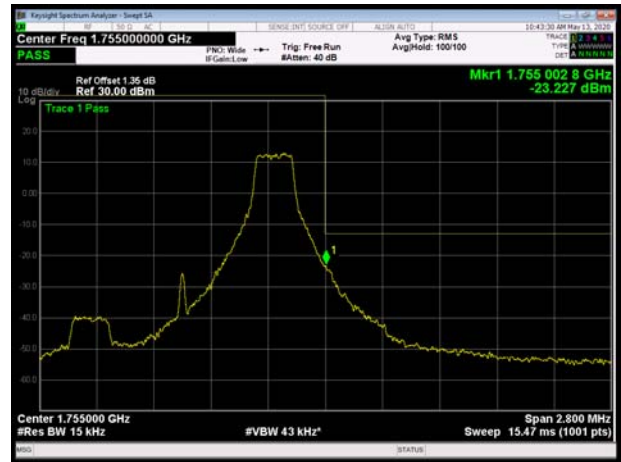

LTE Band 4 16QAM 1.4MHz CH-Low, 100%RB



LTE Band 4 16QAM 1.4MHz CH-High, 100%RB



LTE Band 4 16QAM 3MHz CH-Low, 1 RB

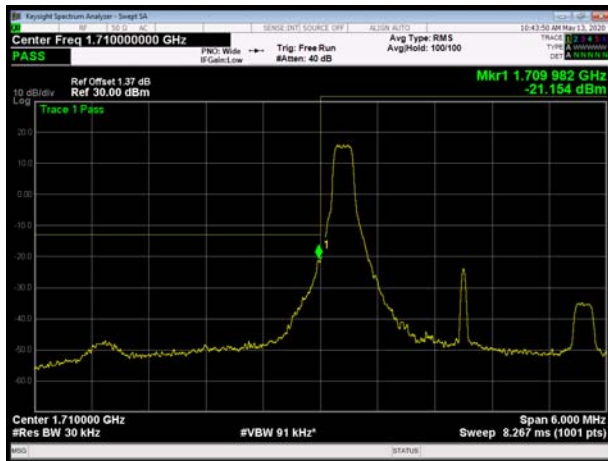

LTE Band 4 16QAM 3MHz CH-High, 1 RB

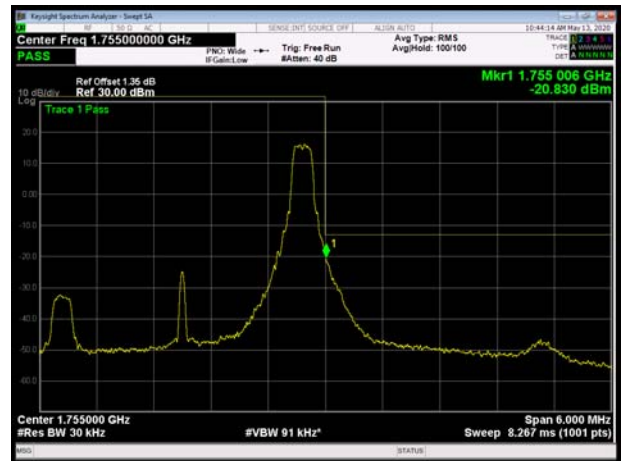



LTE Band 4 16QAM 3MHz CH-Low, 100%RB

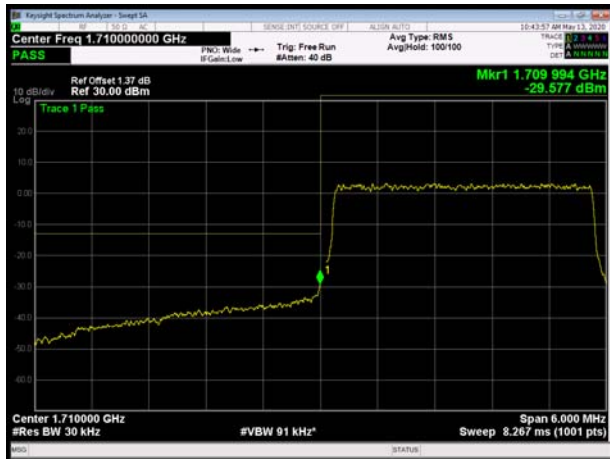

LTE Band 4 16QAM 3MHz CH-High, 100%RB

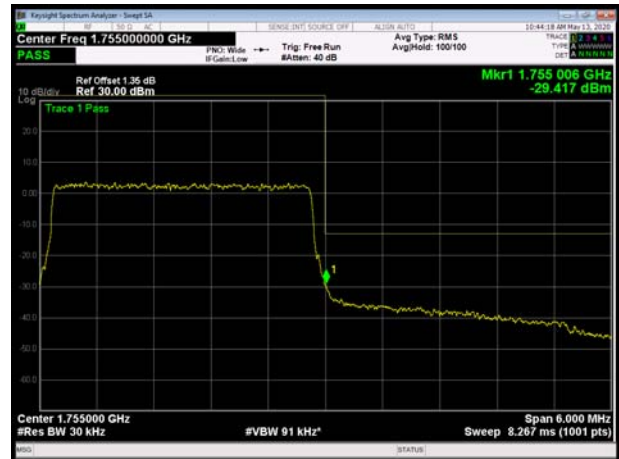

LTE Band 4 16QAM 5MHz CH-Low, 1 RB

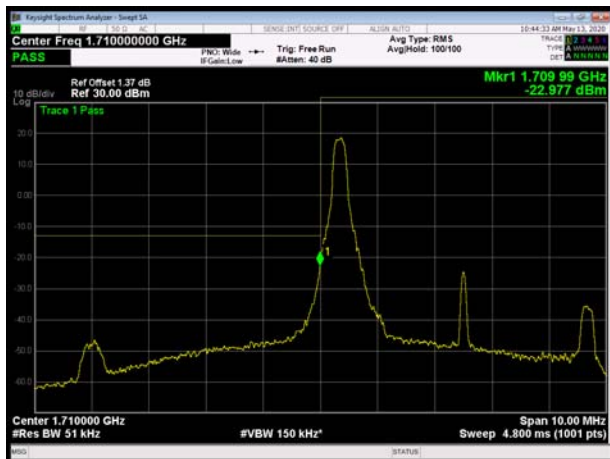

LTE Band 4 16QAM 5MHz CH-High, 1 RB

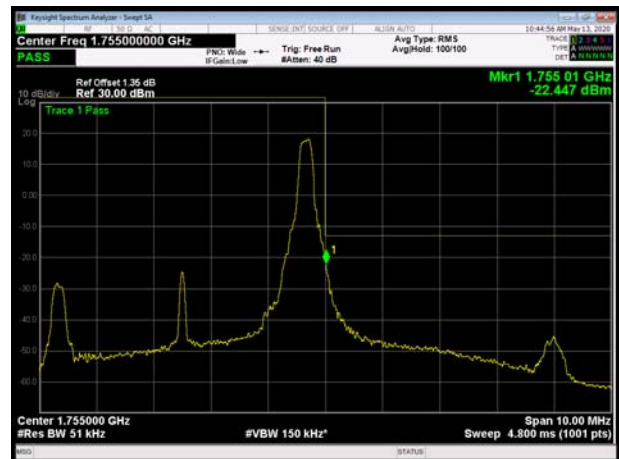

LTE Band 4 16QAM 5MHz CH-Low, 100%RB

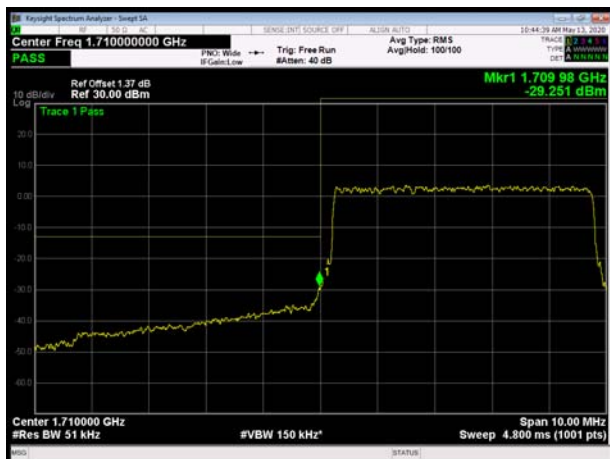

LTE Band 4 16QAM 5MHz CH-High, 100%RB





LTE Band 4 16QAM 10MHz CH-Low, 1 RB

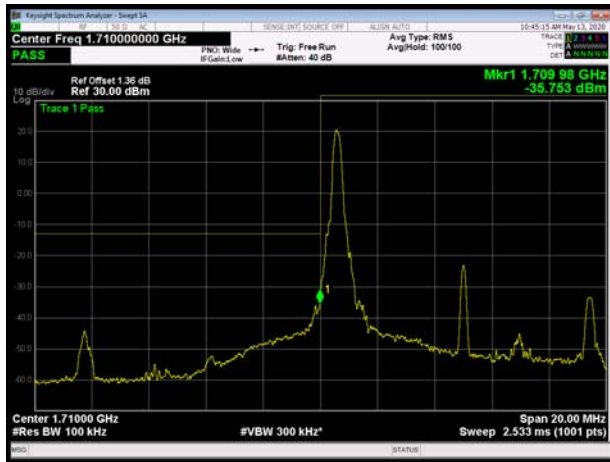

LTE Band 4 16QAM 10MHz CH-High, 1 RB

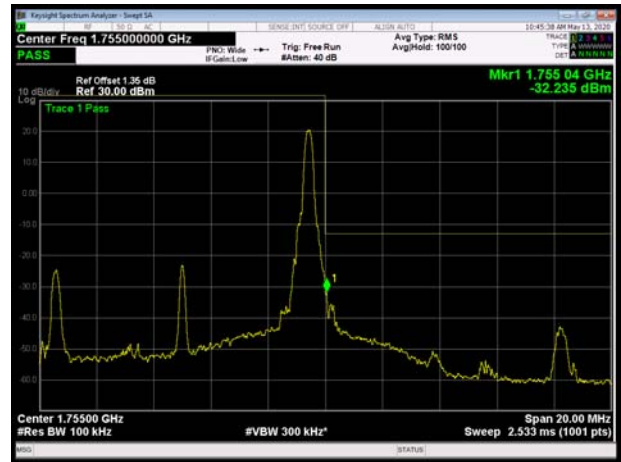

LTE Band 4 16QAM 10MHz CH-Low, 100%RB

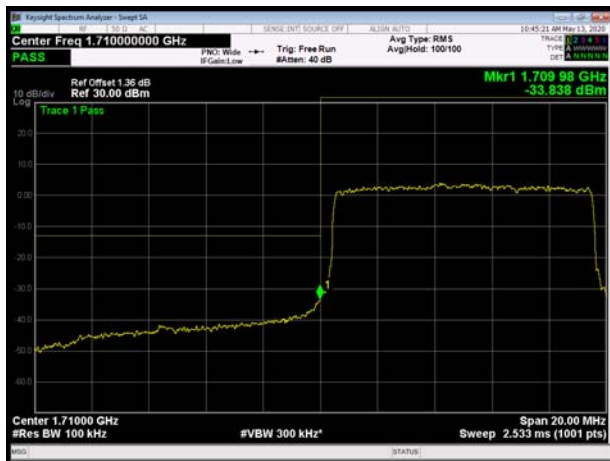

LTE Band 4 16QAM 10MHz CH-High, 100%RB



LTE Band 4 16QAM 15MHz CH-Low, 1 RB

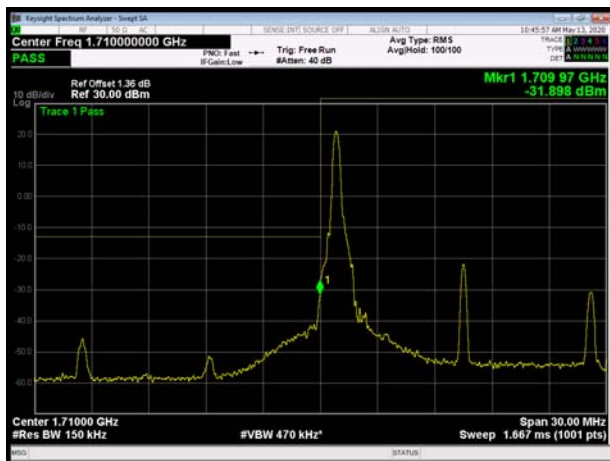

LTE Band 4 16QAM 15MHz CH-High, 1 RB

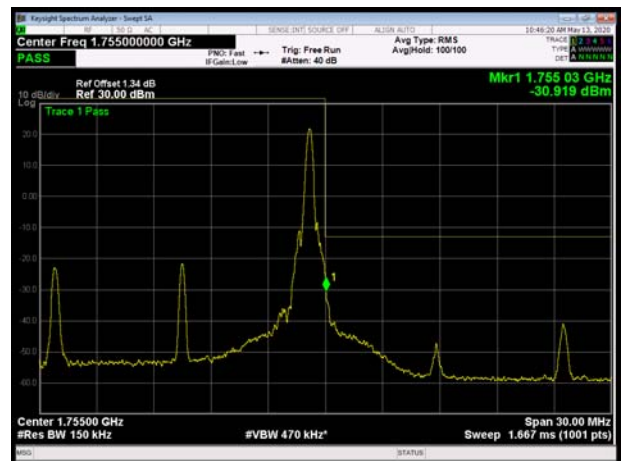



LTE Band 4 16QAM 15MHz CH-Low, 100%RB

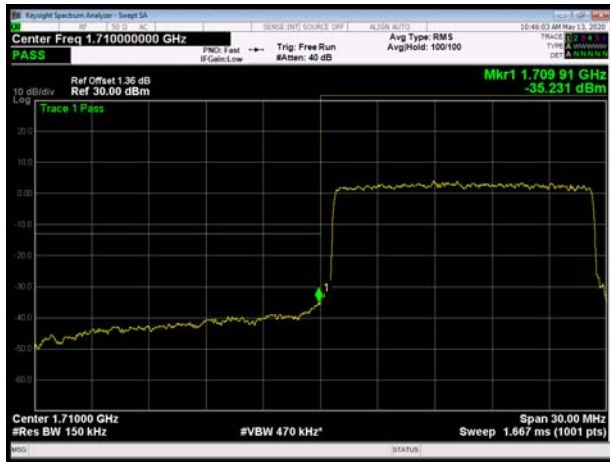

LTE Band 4 16QAM 15MHz CH-High, 100%RB



LTE Band 4 16QAM 20MHz CH-Low, 1 RB

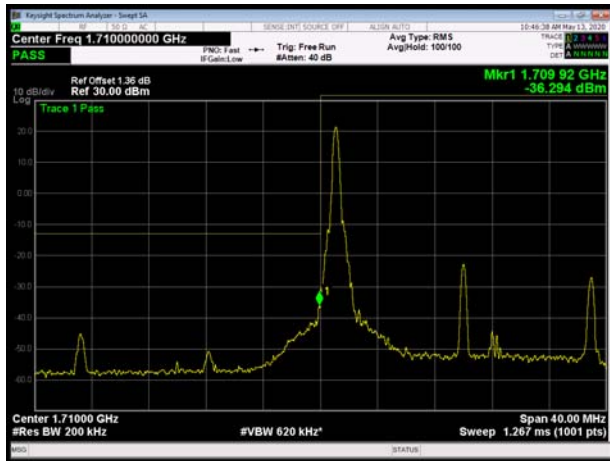

LTE Band 4 16QAM 20MHz CH-High, 1 RB

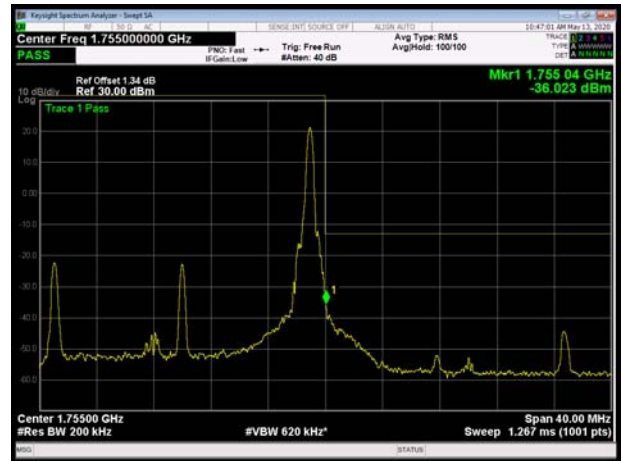

LTE Band 4 16QAM 20MHz CH-Low, 100%RB

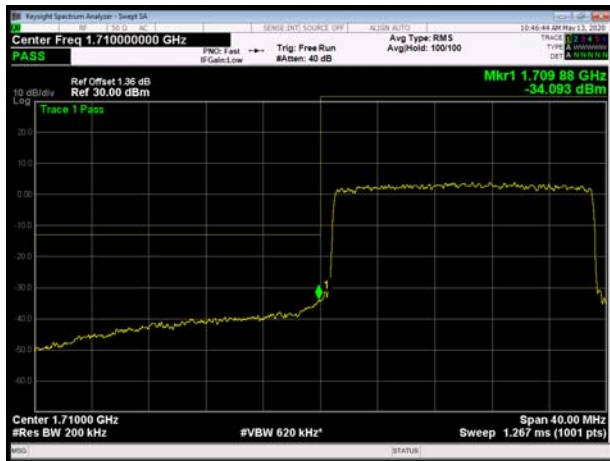

LTE Band 4 16QAM 20MHz CH-High, 100%RB





### LTE Band 7 QPSK 5MHz CH-Low, 1 RB

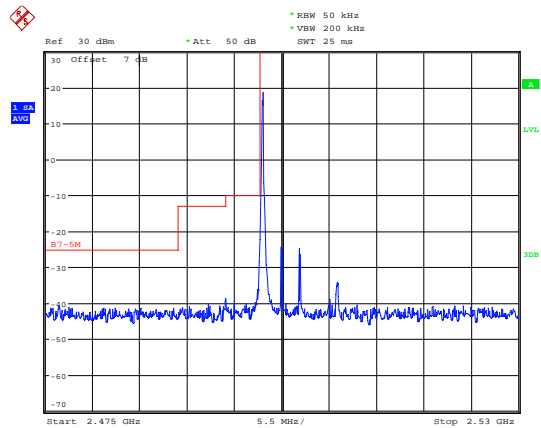

### LTE Band 7 QPSK 5MHz CH-High, 1 RB

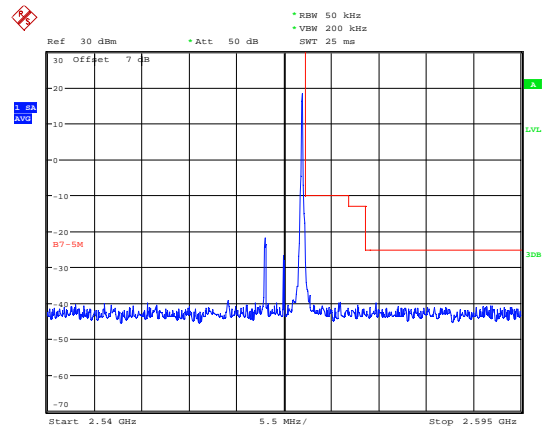

### LTE Band 7 QPSK 5MHz CH-Low, 100%RB

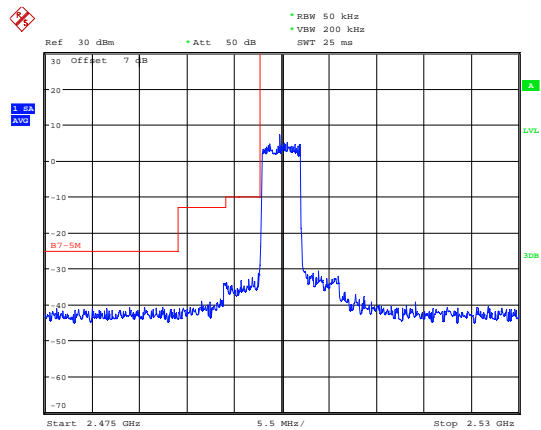

### LTE Band 7 QPSK 5MHz CH-High, 100%RB

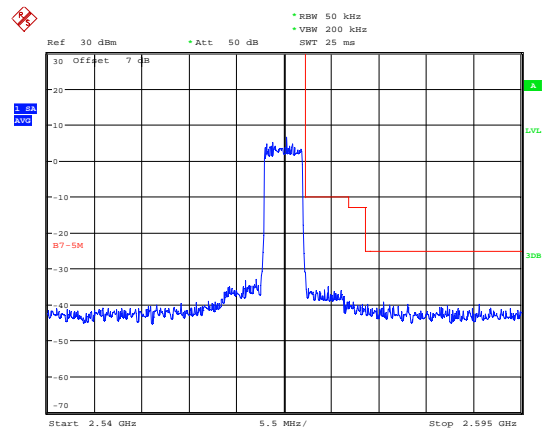

### LTE Band 7 QPSK 10MHz CH-Low, 1 RB

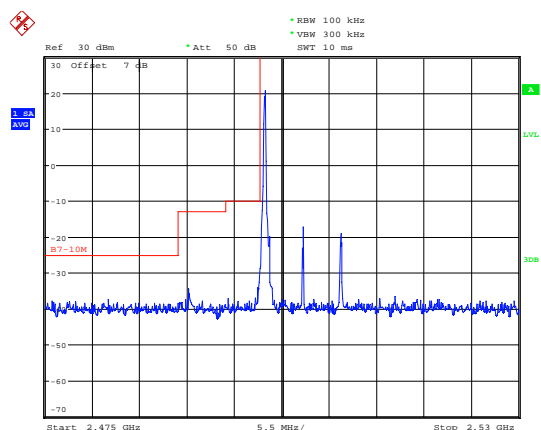

### LTE Band 7 QPSK 10MHz CH-High, 1 RB

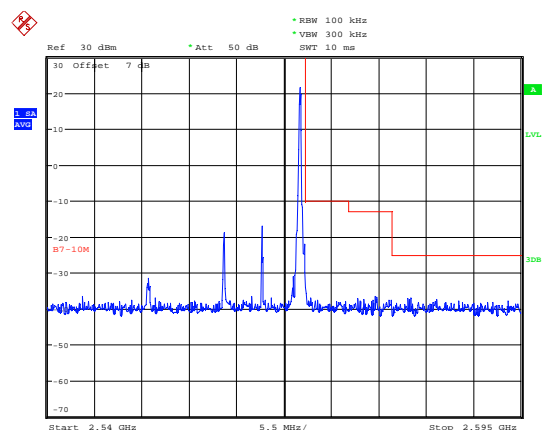



LTE Band 7 QPSK 10MHz CH-Low, 100%RB

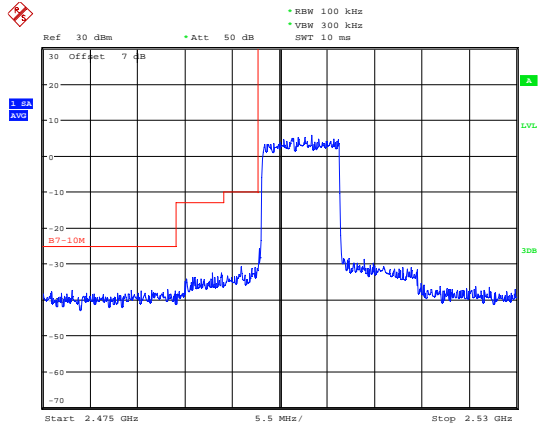

Date: 12.MAY.2020 15:18:20

LTE Band 7 QPSK 10MHz CH-High, 100%RB

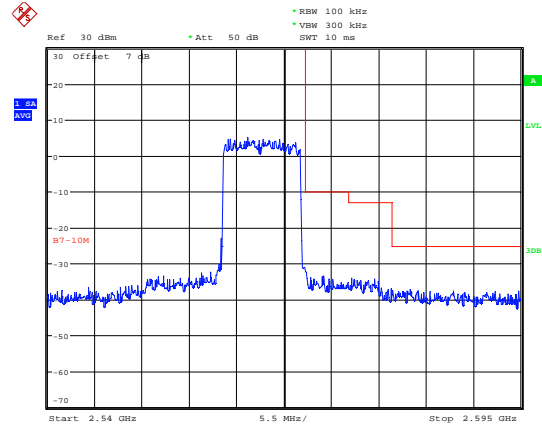

Date: 12.MAY.2020 15:20:42

LTE Band 7 QPSK 15MHz CH-Low, 1 RB

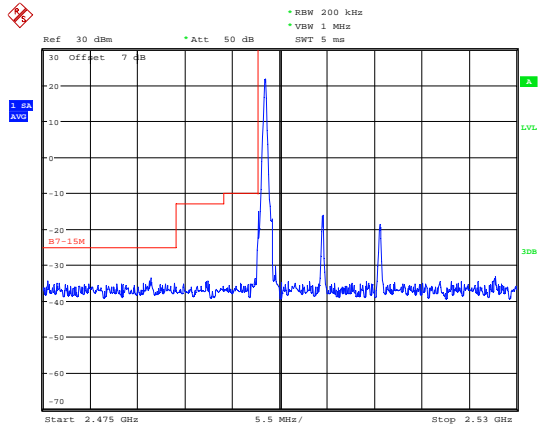

Date: 12.MAY.2020 15:23:00

LTE Band 7 QPSK 15MHz CH-High, 1 RB

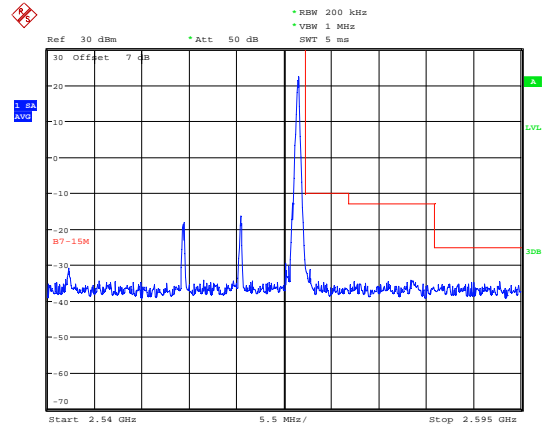

Date: 12.MAY.2020 15:26:37

LTE Band 7 QPSK 15MHz CH-Low, 100%RB

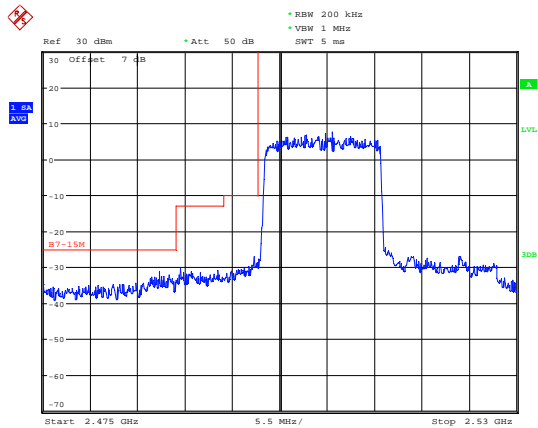

Date: 12.MAY.2020 15:23:14

LTE Band 7 QPSK 15MHz CH-High, 100%RB

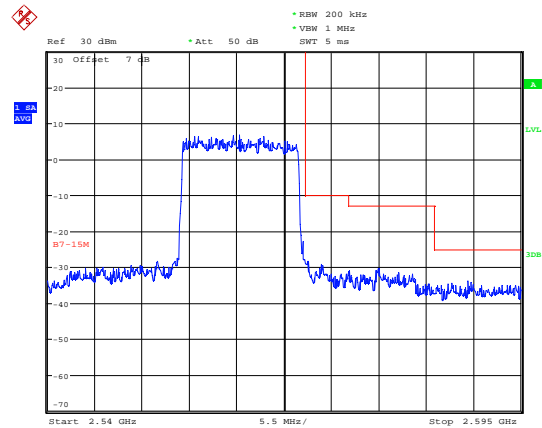

Date: 12.MAY.2020 15:26:54



### LTE Band 7 QPSK 20MHz CH-Low, 1 RB

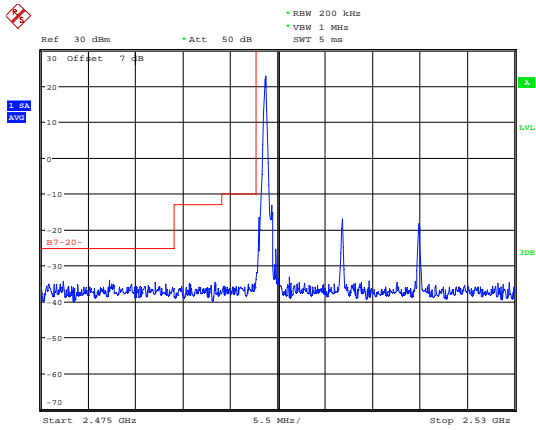

Date: 12.MAY.2020 15:33:25

### LTE Band 7 QPSK 20MHz CH-High, 1 RB

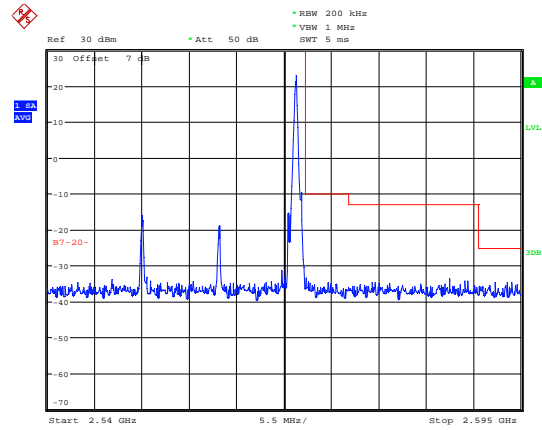

Date: 12.MAY.2020 15:31:23

### LTE Band 7 QPSK 20MHz CH-Low, 100%RB

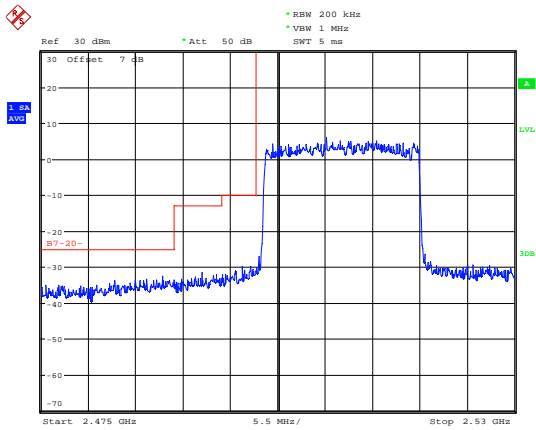

Date: 12.MAY.2020 15:33:45

### LTE Band 7 QPSK 20MHz CH-High, 100%RB

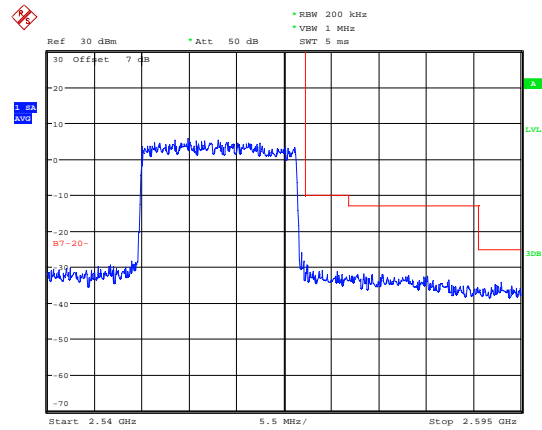

Date: 12.MAY.2020 15:31:42

### LTE Band 7 16QAM 5MHz CH-Low, 1 RB

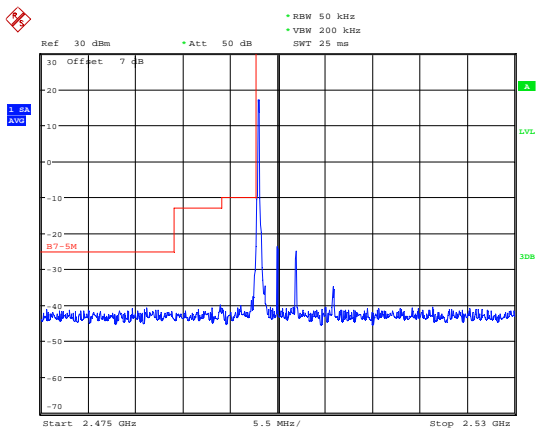

Date: 12.MAY.2020 15:13:10

### LTE Band 7 16QAM 5MHz CH-High, 1 RB

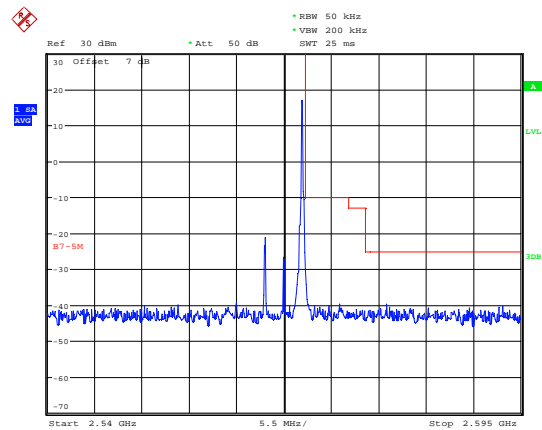

Date: 12.MAY.2020 15:15:44





### LTE Band 7 16QAM 5MHz CH-Low, 100%RB

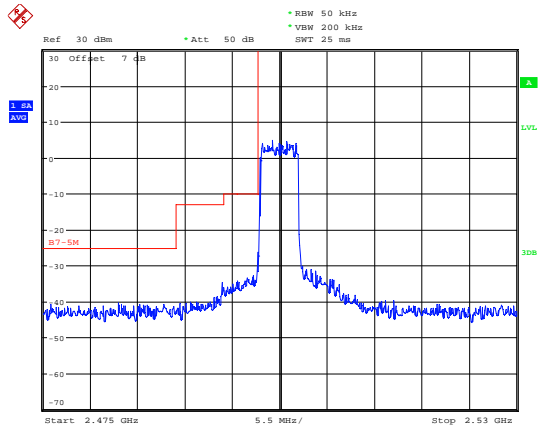

### LTE Band 7 16QAM 5MHz CH-High, 100%RB

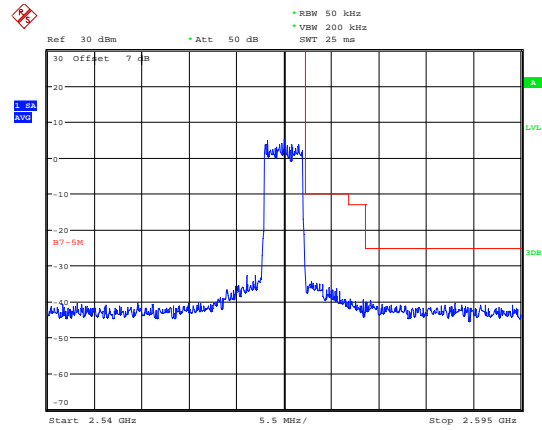

### LTE Band 7 16QAM 10MHz CH-Low, 1 RB

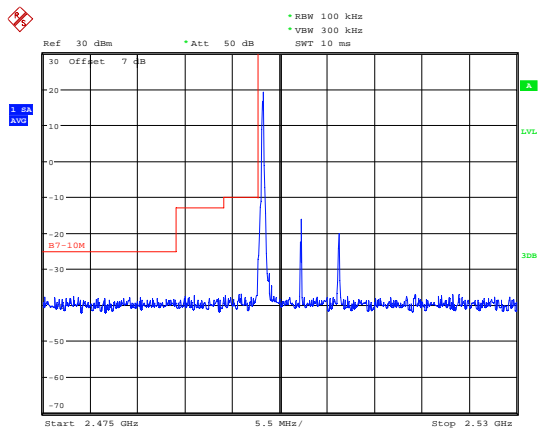

### LTE Band 7 16QAM 10MHz CH-High, 1 RB

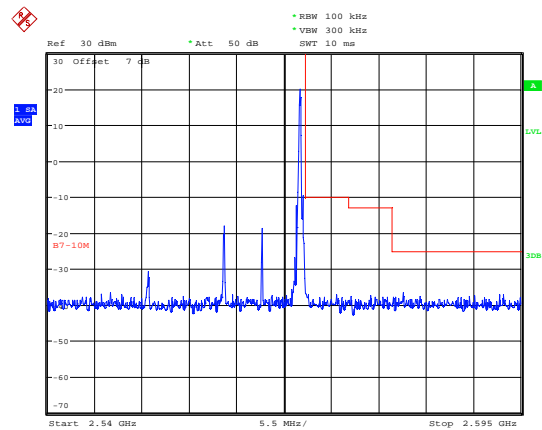

### LTE Band 7 16QAM 10MHz CH-Low, 100%RB

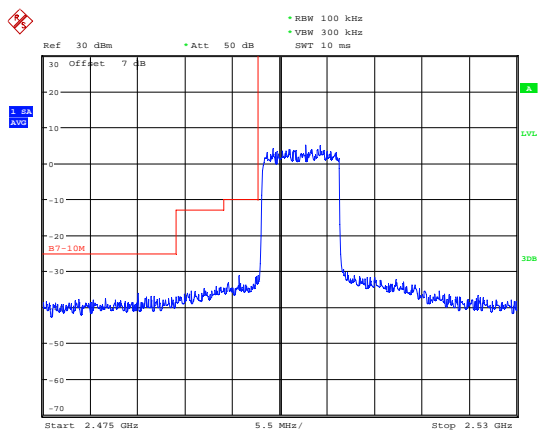

### LTE Band 7 16QAM 10MHz CH-High, 100%RB

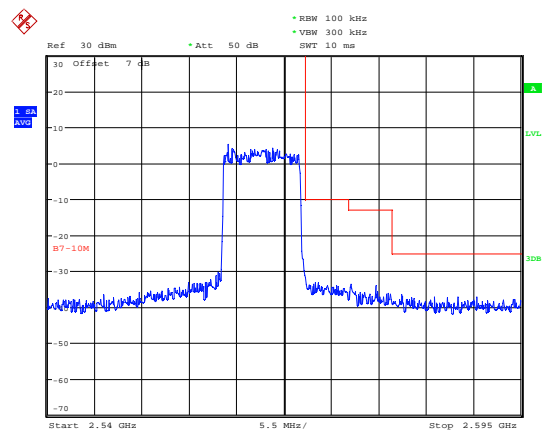



### LTE Band 7 16QAM 15MHz CH-Low, 1 RB

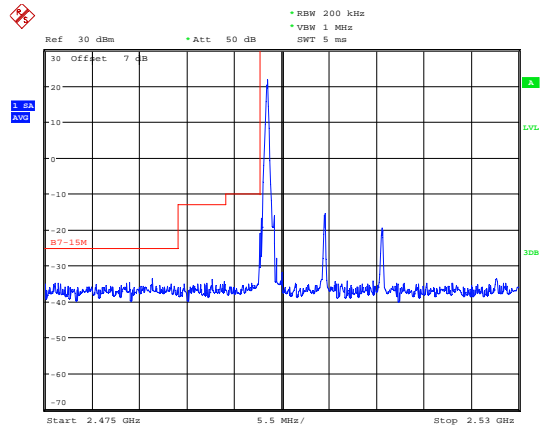

Date: 12.MAY.2020 15:23:36

### LTE Band 7 16QAM 15MHz CH-High, 1 RB

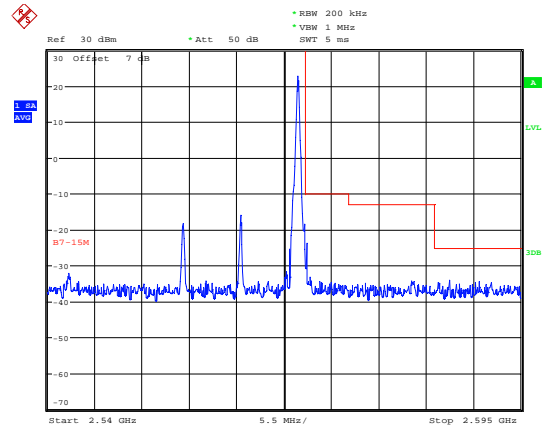

Date: 12.MAY.2020 15:27:12

### LTE Band 7 16QAM 15MHz CH-Low, 100%RB

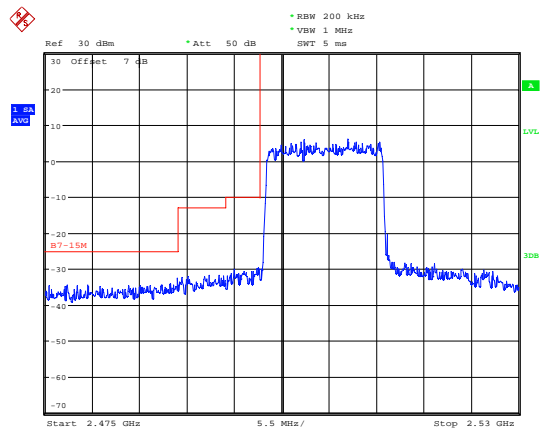

Date: 12.MAY.2020 15:23:55

### LTE Band 7 16QAM 15MHz CH-High, 100%RB

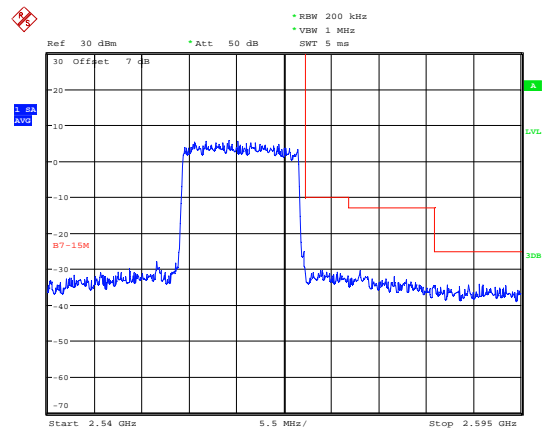

Date: 12.MAY.2020 15:27:49

### LTE Band 7 16QAM 20MHz CH-Low, 1 RB

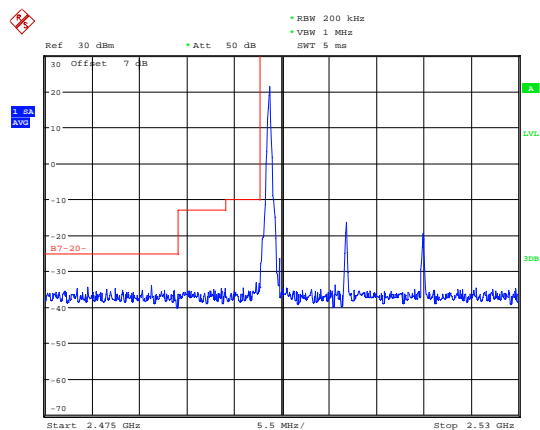

Date: 12.MAY.2020 15:34:05

### LTE Band 7 16QAM 20MHz CH-High, 1 RB

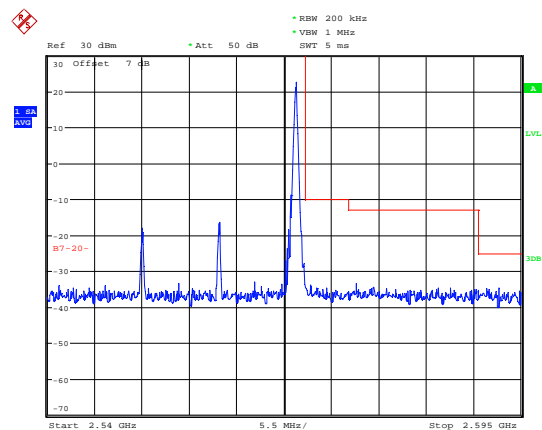

Date: 12.MAY.2020 15:32:18



### LTE Band 7 16QAM 20MHz CH-Low, 100%RB

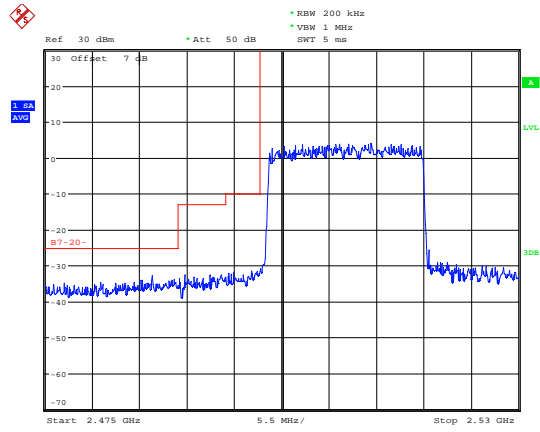

### LTE Band 7 16QAM 20MHz CH-High, 100%RB

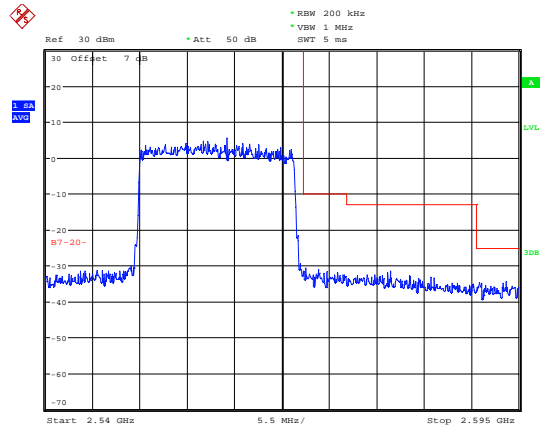

### 5.4 Peak-to-Average Power Ratio (PAPR)

#### Ambient condition

Temperature	Relative humidity	Pressure
23°C ~25°C	45%~50%	101.5kPa

#### Methods of Measurement

Measure the total peak power and record as Ppk. And measure the total average power and record as PAvg. Both the peak and average power levels must be expressed in the same logarithmic units (e.g., dBm). Determine the PAPR from:

$$PAPR (dB) = Ppk (dBm) - PAvg (dBm).$$

#### Test Setup

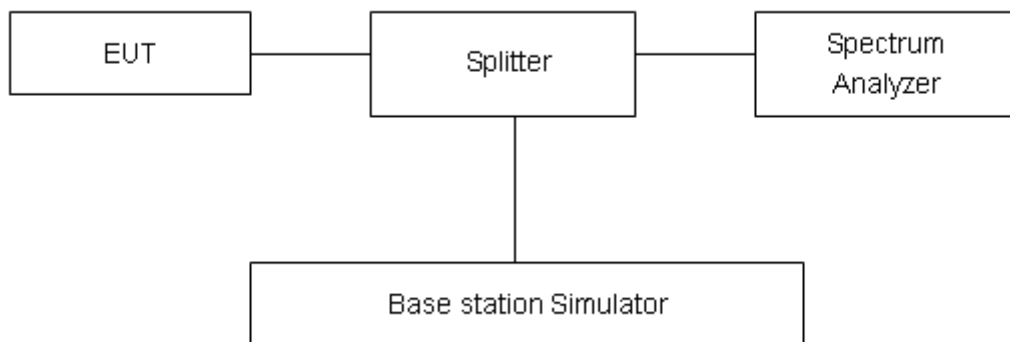

#### Limits

Rule Part 27.50(d)(5) Equipment employed must be authorized in accordance with the provisions of 24.51. Power measurements for transmissions by stations authorized under this section may be made either in accordance with a Commission-approved average power technique or in compliance with paragraph (d)(6) of this section. In measuring transmissions in this band using an average power technique, the peak-to-average ratio (PAR) of the transmission may not exceed 13 dB.

#### Measurement Uncertainty

The assessed measurement uncertainty to ensure 95% confidence level for the normal distribution is with the coverage factor k = 2, U= 0.4 dB.



## Test Results

LTE Band 4								
Modulation	Bandwidth (MHz)	Channel	Frequency (MHz)	Peak (dBm)	Avg (dBm)	PAPR (dB)	Limit (dB)	Conclusion
QPSK	1.4	19957	1710.7	27.87	23.01	4.86	≤13	PASS
		20175	1732.5	27.84	22.79	5.05	≤13	PASS
		20393	1754.3	28.02	22.96	5.06	≤13	PASS
	3	19965	1711.5	27.85	22.87	4.98	≤13	PASS
		20175	1732.5	27.98	22.83	5.15	≤13	PASS
		20385	1753.5	28.18	22.99	5.19	≤13	PASS
	5	19975	1712.5	27.73	22.85	4.88	≤13	PASS
		20175	1732.5	27.95	22.82	5.13	≤13	PASS
		20375	1752.5	28.12	22.97	5.15	≤13	PASS
	10	20000	1715	27.74	22.93	4.81	≤13	PASS
		20175	1732.5	27.96	22.84	5.12	≤13	PASS
		20350	1750	28.22	23.01	5.21	≤13	PASS
	15	20025	1717.5	27.65	22.91	4.74	≤13	PASS
		20175	1732.5	27.92	22.80	5.12	≤13	PASS
		20325	1747.5	28.26	22.96	5.30	≤13	PASS
20	20050	1720	27.64	22.88	4.76	≤13	PASS	
	20175	1732.5	27.84	22.75	5.09	≤13	PASS	
	20300	1745	28.15	22.92	5.23	≤13	PASS	
16QAM	1.4	19957	1710.7	27.20	21.53	5.67	≤13	PASS
		20175	1732.5	27.64	21.77	5.87	≤13	PASS
		20393	1754.3	27.53	21.64	5.89	≤13	PASS
	3	19965	1711.5	27.34	21.56	5.78	≤13	PASS
		20175	1732.5	27.76	21.81	5.95	≤13	PASS
		20385	1753.5	27.68	21.67	6.01	≤13	PASS
	5	19975	1712.5	27.16	21.54	5.62	≤13	PASS
		20175	1732.5	27.65	21.77	5.88	≤13	PASS
		20375	1752.5	27.55	21.62	5.93	≤13	PASS
	10	20000	1715	27.17	21.57	5.60	≤13	PASS
		20175	1732.5	27.70	21.82	5.88	≤13	PASS
		20350	1750	27.65	21.66	5.99	≤13	PASS
	15	20025	1717.5	27.03	21.54	5.49	≤13	PASS
		20175	1732.5	27.60	21.77	5.83	≤13	PASS
		20325	1747.5	27.60	21.62	5.98	≤13	PASS
20	20050	1720	27.07	21.52	5.55	≤13	PASS	
	20175	1732.5	27.54	21.73	5.81	≤13	PASS	
	20300	1745	27.55	21.59	5.96	≤13	PASS	



LTE Band 7								
Modulation	Bandwidth (MHz)	Channel	Frequency (MHz)	Peak (dBm)	Avg (dBm)	PAPR (dB)	Limit (dB)	Conclusion
QPSK	5	20775	2502.5	28.11	22.98	5.13	≤13	PASS
		21100	2535	27.99	23.11	4.88	≤13	PASS
		21425	2567.5	28.15	23.25	4.90	≤13	PASS
	10	20800	2505	28.28	23.06	5.22	≤13	PASS
		21100	2535	28.15	23.13	5.02	≤13	PASS
		21400	2565	28.18	23.11	5.07	≤13	PASS
	15	20825	2507.5	28.20	23.04	5.16	≤13	PASS
		21100	2535	28.14	23.09	5.05	≤13	PASS
		21375	2562.5	28.21	23.06	5.15	≤13	PASS
	20	20850	2510	28.07	23.01	5.06	≤13	PASS
		21100	2535	28.18	23.04	5.14	≤13	PASS
		21350	2560	28.19	23.02	5.17	≤13	PASS
16QAM	5	20775	2502.5	27.93	22.00	5.93	≤13	PASS
		21100	2535	27.76	22.06	5.70	≤13	PASS
		21425	2567.5	27.55	21.84	5.71	≤13	PASS
	10	20800	2505	28.08	22.03	6.05	≤13	PASS
		21100	2535	27.95	22.11	5.84	≤13	PASS
		21400	2565	27.77	21.88	5.89	≤13	PASS
	15	20825	2507.5	27.95	22.00	5.95	≤13	PASS
		21100	2535	27.88	22.06	5.82	≤13	PASS
		21375	2562.5	27.79	21.84	5.95	≤13	PASS
	20	20850	2510	27.83	21.98	5.85	≤13	PASS
		21100	2535	27.92	22.02	5.90	≤13	PASS
		21350	2560	27.81	21.81	6.00	≤13	PASS



## 5.5 Frequency Stability

### Ambient condition

Temperature	Relative humidity	Pressure
23°C ~25°C	45%~50%	101.5kPa

### Method of Measurement

#### Frequency Stability (Temperature Variation)

The temperature inside the climate chamber is varied from -40°C to +85°C in 10°C step size.

(1) With all power removed, the temperature was decreased to -10°C and permitted to stabilize for three hours.

(2) Measure the carrier frequency with the test equipment in a “call mode”. These measurements should be made within 1 minute of powering up the mobile station, to prevent significant self warming.

(3) Repeat the above measurements at 10°C increments from -40°C to +85°C. Allow at least 1.5 hours at each temperature, un-powered, before making measurements.

#### Frequency Stability (Voltage Variation)

The frequency stability shall be measured with variation of primary supply voltage as follows:

(1) Vary primary supply voltage from 85 to 115 percent of the nominal value for other than hand carried battery equipment.

(2) For hand carried, battery powered equipment, reduce primary supply voltage to the battery-operating end point which shall be specified by the manufacturer.

This transceiver is specified to operate with an input voltage of between 3.3 V and 4.3 V, with a nominal voltage of 3.8V.

### Test setup

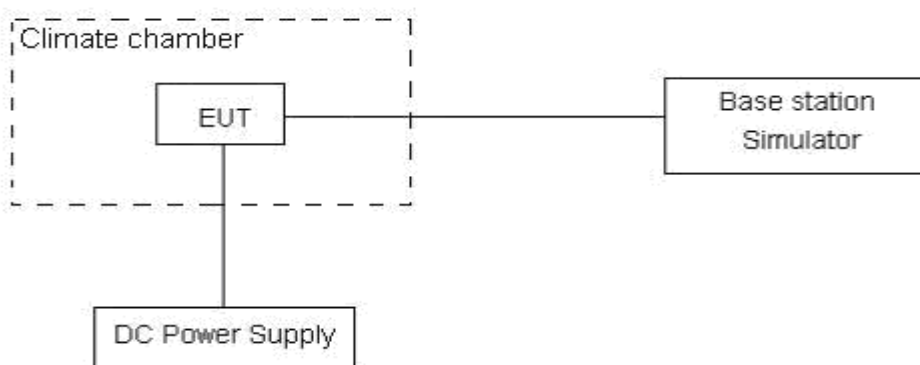

### Limits

The frequency stability shall be sufficient to ensure that the fundamental emissions stay within the authorized bands of operation.

### Measurement Uncertainty

The assessed measurement uncertainty to ensure 99.75% confidence level for the normal distribution is with the coverage factor  $k = 3, U = 0.01\text{ppm}$ .



## Test Result

LTE Band 4						
Condition		Freq.Error (Hz)	Freq.Error (Hz)	Frequency Stability (ppm)	Frequency Stability (ppm)	Verdict
BANDWIDTH	1.4MHz					
Temperature	Voltage	16QAM	QPSK	16QAM	QPSK	
Normal (25°C)	Normal	2.72	15.52	0.00144	0.00825	PASS
Extreme (85°C)		8.98	5.14	0.00478	0.00273	PASS
Extreme (80°C)		8.83	1.96	0.00470	0.00104	PASS
Extreme (70°C)		6.55	11.10	0.00348	0.00590	PASS
Extreme (60°C)		11.97	8.52	0.00637	0.00453	PASS
Extreme (50°C)		5.46	3.34	0.00291	0.00177	PASS
Extreme (40°C)		5.77	6.04	0.00307	0.00321	PASS
Extreme (30°C)		7.52	11.84	0.00400	0.00630	PASS
Extreme (20°C)		10.26	11.21	0.00546	0.00596	PASS
Extreme (10°C)		3.72	11.94	0.00198	0.00635	PASS
Extreme (0°C)		9.01	3.93	0.00479	0.00209	PASS
Extreme (-10°C)		8.31	8.32	0.00442	0.00442	PASS
Extreme (-20°C)		5.41	5.61	0.00288	0.00299	PASS
Extreme (-30°C)		12.77	13.33	0.00679	0.00709	PASS
Extreme (-40°C)		2.96	10.76	0.00157	0.00573	PASS
25°C	LV	7.00	10.97	0.00372	0.00583	PASS
	HV	7.76	13.17	0.00413	0.00701	PASS
Condition		Freq.Error (Hz)	Freq.Error (Hz)	Frequency Stability (ppm)	Frequency Stability (ppm)	Verdict
BANDWIDTH	3MHz					
Temperature	Voltage	16QAM	QPSK	16QAM	QPSK	
Normal (25°C)	Normal	2.60	3.94	0.00139	0.00210	PASS
Extreme (85°C)		14.56	16.11	0.00775	0.00857	PASS
Extreme (80°C)		6.45	3.57	0.00343	0.00190	PASS
Extreme (70°C)		8.57	9.50	0.00456	0.00505	PASS
Extreme (60°C)		8.16	15.97	0.00434	0.00849	PASS
Extreme (50°C)		12.61	3.28	0.00671	0.00175	PASS
Extreme (40°C)		9.60	3.04	0.00511	0.00162	PASS
Extreme (30°C)		2.40	2.50	0.00128	0.00133	PASS
Extreme (20°C)		1.37	9.52	0.00073	0.00506	PASS
Extreme (10°C)		2.10	5.71	0.00112	0.00304	PASS
Extreme (0°C)		12.35	4.67	0.00657	0.00249	PASS
Extreme (-10°C)		2.82	12.01	0.00150	0.00639	PASS
Extreme (-20°C)		6.43	1.78	0.00342	0.00095	PASS
Extreme (-30°C)		9.83	8.37	0.00523	0.00445	PASS



Condition		Freq.Error (Hz)	Freq.Error (Hz)	Frequency Stability (ppm)	Frequency Stability (ppm)	Verdict
BANDWIDTH	5MHz	16QAM	QPSK	16QAM	QPSK	
Extreme (-40°C)		2.51	15.36	0.00134	0.00817	PASS
25°C	LV	8.81	14.77	0.00468	0.00786	PASS
	HV	10.31	3.37	0.00548	0.00179	PASS
Condition		Freq.Error (Hz)	Freq.Error (Hz)	Frequency Stability (ppm)	Frequency Stability (ppm)	Verdict
BANDWIDTH	5MHz	16QAM	QPSK	16QAM	QPSK	
Normal (25°C)	Normal	12.73	14.39	0.00677	0.00765	PASS
Extreme (85°C)		4.20	3.38	0.00223	0.00180	PASS
Extreme (80°C)		4.00	5.87	0.00213	0.00312	PASS
Extreme (70°C)		9.32	4.12	0.00496	0.00219	PASS
Extreme (60°C)		2.31	9.59	0.00123	0.00510	PASS
Extreme (50°C)		17.50	16.91	0.00931	0.00899	PASS
Extreme (40°C)		6.53	9.40	0.00347	0.00500	PASS
Extreme (30°C)		7.94	8.77	0.00422	0.00466	PASS
Extreme (20°C)		7.48	13.17	0.00398	0.00700	PASS
Extreme (10°C)		14.75	2.70	0.00784	0.00144	PASS
Extreme (0°C)		14.17	17.62	0.00754	0.00937	PASS
Extreme (-10°C)		11.55	10.29	0.00615	0.00547	PASS
Extreme (-20°C)		12.41	15.68	0.00660	0.00834	PASS
Extreme (-30°C)		5.21	14.47	0.00277	0.00769	PASS
Extreme (-40°C)		6.28	6.60	0.00334	0.00351	PASS
25°C		LV	17.75	6.55	0.00944	0.00348
	HV	5.69	10.54	0.00302	0.00561	PASS
Condition		Freq.Error (Hz)	Freq.Error (Hz)	Frequency Stability (ppm)	Frequency Stability (ppm)	Verdict
BANDWIDTH	10MHz	16QAM	QPSK	16QAM	QPSK	
Normal (25°C)	Normal	10.10	4.17	0.00537	0.00222	PASS
Extreme (85°C)		9.16	15.75	0.00487	0.00838	PASS
Extreme (80°C)		9.50	17.01	0.00505	0.00905	PASS
Extreme (70°C)		9.73	4.59	0.00517	0.00244	PASS
Extreme (60°C)		15.19	5.22	0.00808	0.00278	PASS
Extreme (50°C)		10.20	1.90	0.00543	0.00101	PASS
Extreme (40°C)		3.44	6.62	0.00183	0.00352	PASS
Extreme (30°C)		17.30	8.28	0.00920	0.00440	PASS
Extreme (20°C)		2.68	9.01	0.00143	0.00479	PASS
Extreme (10°C)		10.39	3.54	0.00553	0.00188	PASS
Extreme (0°C)		1.63	17.80	0.00087	0.00947	PASS
Extreme (-10°C)		12.49	8.15	0.00664	0.00434	PASS
Extreme (-20°C)		17.67	7.74	0.00940	0.00412	PASS
Extreme (-30°C)		15.56	14.33	0.00828	0.00762	PASS



Extreme (-40℃)		14.70	17.70	0.00782	0.00941	PASS
25℃	LV	16.09	1.07	0.00856	0.00057	PASS
	HV	2.84	11.68	0.00151	0.00621	PASS
Condition		Freq.Error (Hz)	Freq.Error (Hz)	Frequency Stability (ppm)	Frequency Stability (ppm)	Verdict
BANDWIDTH	15MHz					
Temperature	Voltage	16QAM	QPSK	16QAM	QPSK	
Normal (25℃)	Normal	5.88	6.98	0.00313	0.00372	PASS
Extreme (85℃)		15.35	14.81	0.00816	0.00788	PASS
Extreme (80℃)		17.65	11.86	0.00939	0.00631	PASS
Extreme (70℃)		16.02	17.57	0.00852	0.00935	PASS
Extreme (60℃)		16.27	10.38	0.00865	0.00552	PASS
Extreme (50℃)		8.91	4.26	0.00474	0.00227	PASS
Extreme (40℃)		17.00	7.90	0.00904	0.00420	PASS
Extreme (30℃)		17.94	7.37	0.00954	0.00392	PASS
Extreme (20℃)		9.30	12.80	0.00495	0.00681	PASS
Extreme (10℃)		10.54	2.37	0.00561	0.00126	PASS
Extreme (0℃)		9.20	9.78	0.00490	0.00520	PASS
Extreme (-10℃)		1.48	10.71	0.00079	0.00570	PASS
Extreme (-20℃)		14.16	11.33	0.00753	0.00603	PASS
Extreme (-30℃)		5.83	13.70	0.00310	0.00729	PASS
Extreme (-40℃)		5.89	4.65	0.00313	0.00247	PASS
25℃	LV	17.65	16.12	0.00939	0.00858	PASS
	HV	16.16	1.75	0.00859	0.00093	PASS
Condition		Freq.Error (Hz)	Freq.Error (Hz)	Frequency Stability (ppm)	Frequency Stability (ppm)	Verdict
BANDWIDTH	20MHz					
Temperature	Voltage	16QAM	QPSK	16QAM	QPSK	
Normal (25℃)	Normal	2.03	11.78	0.00108	0.00626	PASS
Extreme (85℃)		16.14	5.52	0.00859	0.00294	PASS
Extreme (80℃)		16.07	17.59	0.00855	0.00935	PASS
Extreme (70℃)		15.00	5.98	0.00798	0.00318	PASS
Extreme (60℃)		10.29	3.42	0.00547	0.00182	PASS
Extreme (50℃)		1.26	16.50	0.00067	0.00878	PASS
Extreme (40℃)		7.75	1.11	0.00412	0.00059	PASS
Extreme (30℃)		5.80	17.84	0.00309	0.00949	PASS
Extreme (20℃)		5.17	15.31	0.00275	0.00814	PASS
Extreme (10℃)		7.31	5.08	0.00389	0.00270	PASS
Extreme (0℃)		6.35	6.61	0.00338	0.00351	PASS
Extreme (-10℃)		12.81	4.72	0.00681	0.00251	PASS
Extreme (-20℃)		1.88	10.38	0.00100	0.00552	PASS
Extreme (-30℃)	7.91	7.53	0.00421	0.00400	PASS	



Extreme (-40°C)		11.65	2.94	0.00620	0.00156	PASS
25°C	LV	9.92	4.72	0.00528	0.00251	PASS
	HV	2.93	2.08	0.00156	0.00111	PASS

LTE Band 7						
Condition		Freq.Error (Hz)	Freq.Error (Hz)	Frequency Stability (ppm)	Frequency Stability (ppm)	Verdict
BANDWIDTH	5MHz					
Temperature	Voltage	16QAM	QPSK	16QAM	QPSK	
Normal (25°C)	Normal	3.99	12.39	0.00212	0.00659	PASS
Extreme (85°C)		1.85	5.69	0.00098	0.00302	PASS
Extreme (80°C)		7.17	11.76	0.00381	0.00626	PASS
Extreme (70°C)		1.40	4.41	0.00074	0.00235	PASS
Extreme (60°C)		9.45	4.87	0.00503	0.00259	PASS
Extreme (50°C)		13.00	10.75	0.00692	0.00572	PASS
Extreme (40°C)		7.82	2.04	0.00416	0.00108	PASS
Extreme (30°C)		13.25	8.14	0.00705	0.00433	PASS
Extreme (20°C)		17.74	5.66	0.00943	0.00301	PASS
Extreme (10°C)		2.12	2.82	0.00113	0.00150	PASS
Extreme (0°C)		15.60	9.69	0.00830	0.00515	PASS
Extreme (-10°C)		15.30	8.57	0.00814	0.00456	PASS
Extreme (-20°C)		6.07	11.21	0.00323	0.00596	PASS
Extreme (-30°C)		7.44	2.46	0.00395	0.00131	PASS
Extreme (-40°C)		9.46	10.19	0.00503	0.00542	PASS
25°C	LV	5.83	15.43	0.00310	0.00821	PASS
	HV	3.21	6.31	0.00171	0.00336	PASS
Condition		Freq.Error (Hz)	Freq.Error (Hz)	Frequency Stability (ppm)	Frequency Stability (ppm)	Verdict
BANDWIDTH	10MHz					
Temperature	Voltage	16QAM	QPSK	16QAM	QPSK	
Normal (25°C)	Normal	6.59	8.55	0.00351	0.00455	PASS
Extreme (85°C)		3.61	16.86	0.00192	0.00897	PASS
Extreme (80°C)		6.22	1.01	0.00331	0.00053	PASS
Extreme (70°C)		13.14	7.57	0.00699	0.00403	PASS
Extreme (60°C)		3.06	12.56	0.00163	0.00668	PASS
Extreme (50°C)		7.06	4.17	0.00376	0.00222	PASS
Extreme (40°C)		14.76	14.30	0.00785	0.00761	PASS
Extreme (30°C)		4.46	3.38	0.00237	0.00180	PASS
Extreme (20°C)		16.17	4.88	0.00860	0.00260	PASS
Extreme (10°C)		9.40	4.96	0.00500	0.00264	PASS
Extreme (0°C)		2.55	2.64	0.00136	0.00141	PASS



Extreme (-10°C)		8.26	11.45	0.00439	0.00609	PASS
Extreme (-20°C)		15.60	15.92	0.00830	0.00847	PASS
Extreme (-30°C)		17.55	3.09	0.00933	0.00164	PASS
Extreme (-40°C)		17.70	9.97	0.00942	0.00530	PASS
25°C	LV	16.12	4.49	0.00857	0.00239	PASS
	HV	7.62	5.93	0.00405	0.00316	PASS
Condition		Freq.Error (Hz)	Freq.Error (Hz)	Frequency Stability (ppm)	Frequency Stability (ppm)	Verdict
BANDWIDTH	15MHz					
Temperature	Voltage					
Normal (25°C)	Normal	6.87	16.26	0.00366	0.00865	PASS
Extreme (85°C)		3.45	10.66	0.00183	0.00567	PASS
Extreme (80°C)		12.43	4.26	0.00661	0.00227	PASS
Extreme (70°C)		8.70	4.32	0.00463	0.00230	PASS
Extreme (60°C)		17.15	8.41	0.00912	0.00447	PASS
Extreme (50°C)		16.03	3.10	0.00853	0.00165	PASS
Extreme (40°C)		14.42	3.24	0.00767	0.00172	PASS
Extreme (30°C)		13.60	7.75	0.00723	0.00412	PASS
Extreme (20°C)		1.42	1.64	0.00076	0.00087	PASS
Extreme (10°C)		6.77	12.81	0.00360	0.00681	PASS
Extreme (0°C)		12.83	2.66	0.00683	0.00142	PASS
Extreme (-10°C)		13.92	11.90	0.00741	0.00633	PASS
Extreme (-20°C)		15.32	2.00	0.00815	0.00106	PASS
Extreme (-30°C)		16.54	1.64	0.00880	0.00087	PASS
Extreme (-40°C)	13.90	17.94	0.00739	0.00955	PASS	
25°C	LV	4.85	11.28	0.00258	0.00600	PASS
	HV	5.69	15.10	0.00303	0.00803	PASS
Condition		Freq.Error (Hz)	Freq.Error (Hz)	Frequency Stability (ppm)	Frequency Stability (ppm)	Verdict
BANDWIDTH	20MHz					
Temperature	Voltage					
Normal (25°C)	Normal	15.54	1.00	0.00827	0.00053	PASS
Extreme (85°C)		9.98	14.01	0.00531	0.00745	PASS
Extreme (80°C)		3.20	10.30	0.00170	0.00548	PASS
Extreme (70°C)		7.12	6.75	0.00379	0.00359	PASS
Extreme (60°C)		4.95	8.06	0.00263	0.00429	PASS
Extreme (50°C)		4.37	6.42	0.00232	0.00341	PASS
Extreme (40°C)		17.20	12.13	0.00915	0.00645	PASS
Extreme (30°C)		13.78	11.35	0.00733	0.00604	PASS
Extreme (20°C)		4.65	3.08	0.00248	0.00164	PASS
Extreme (10°C)		12.08	1.40	0.00642	0.00075	PASS





Extreme (0°C)		2.05	5.50	0.00109	0.00293	PASS
Extreme (-10°C)		16.41	17.68	0.00873	0.00940	PASS
Extreme (-20°C)		6.04	1.06	0.00321	0.00056	PASS
Extreme (-30°C)		9.34	10.31	0.00497	0.00548	PASS
Extreme (-40°C)		7.14	14.99	0.00380	0.00797	PASS
25°C	LV	7.32	16.22	0.00389	0.00863	PASS
	HV	2.78	10.53	0.00148	0.00560	PASS

## 5.6 Spurious Emissions at Antenna Terminals

### Ambient condition

Temperature	Relative humidity	Pressure
23°C ~25°C	45%~50%	101.5kPa

### Method of Measurement

The EUT was connected to Spectrum Analyzer and Base Station Simulator via power Splitter. The measurement is carried out using a spectrum analyzer. The spectrum analyzer scans from 9kHz to the 10th harmonic of the carrier. The peak detector is used.

RBW is set to 100kHz, VBW is set to 300kHz for 30MHz~1GHz

RBW is set to 1MHz, VBW is set to 3MHz for above 1GHz, Sweep is set to ATUO.

Of those disturbances below (limit – 20 dB), the mark is not required for the EUT.

The modulation mode and RB allocation refer to section 5.1, using the maximum output power configuration.

### Test setup

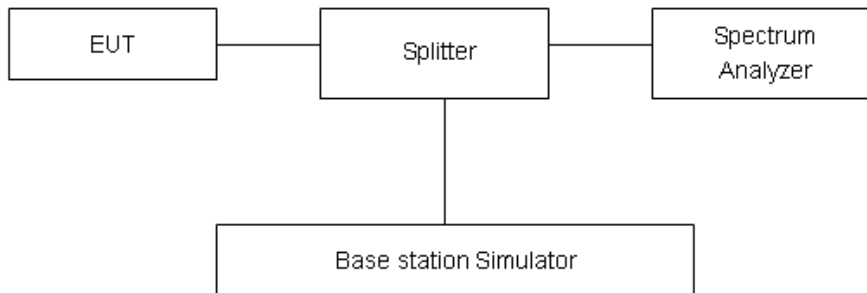

### Limits

Rule Part 27.53(h) specifies that “for operations in the 1695-1710 MHz, 1710-1755 MHz, 1755-1780 MHz, 1915-1920 MHz, 1995-2000 MHz, 2000-2020 MHz, 2110-2155 MHz, 2155-2180 MHz, and 2180-2200 bands, the power of any emission outside a licensee's frequency block shall be attenuated below the transmitter power (P) in watts by at least  $43 + 10 \log_{10}(P)$  dB..”

Rule Part 27.53(m)  $55 + 10 \log(P)$  dB on all frequencies more than X megahertz from the channel edge, where X is the greater of 6 megahertz or the actual emission bandwidth as defined in paragraph (m)(4) of this section.

Part 27.53(a)/(h)/(g) Limit	-13 dBm
Part 27.53(m) Limit	-25 dBm

**Measurement Uncertainty**

The assessed measurement uncertainty to ensure 99.75% confidence level for the normal distribution is with the coverage factor  $k = 1.96$ .

Frequency	Uncertainty
9kHz-1GHz	0.684 dB
1GHz-27GHz	1.407 dB



### Test Result

Sweep the whole frequency band through the range from 9kHz to the 10th harmonic of the carrier, the emissions more than 20 dB below the limit are not reported.

The signal beyond the limit is carrier.

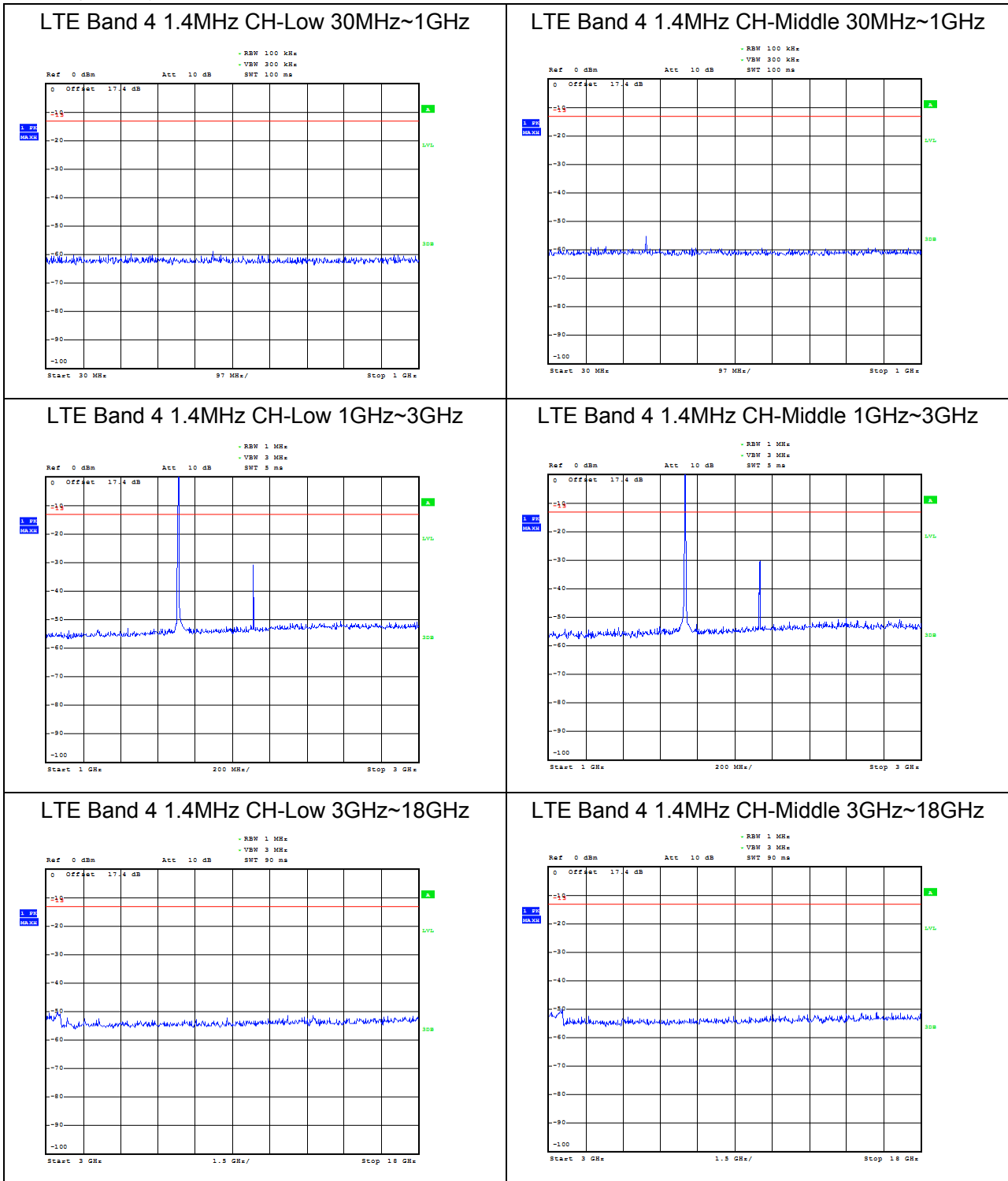



### LTE Band 4 1.4MHz CH-High 30MHz~1GHz

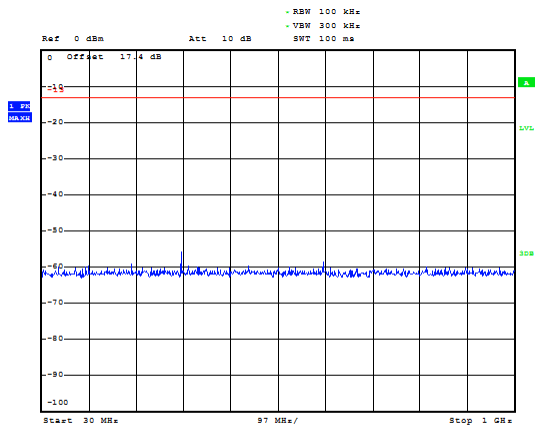

### LTE Band 4 3MHz CH-Low 30MHz~1GHz

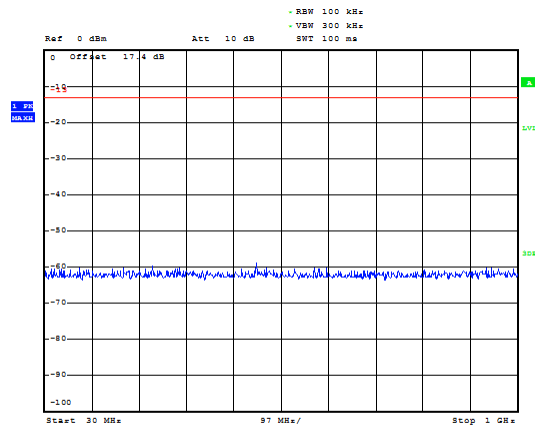

### LTE Band 4 1.4MHz CH-High 1GHz~3GHz

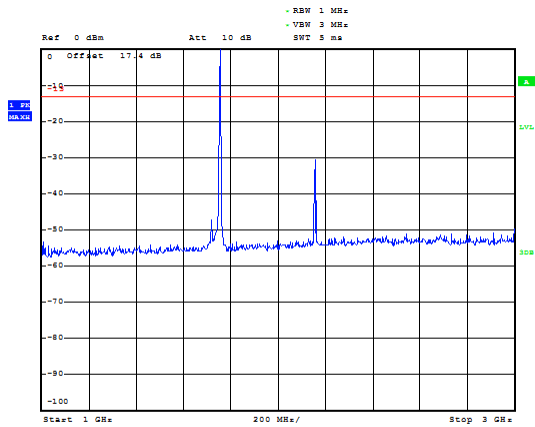

### LTE Band 4 3MHz CH-Low 1GHz~3GHz

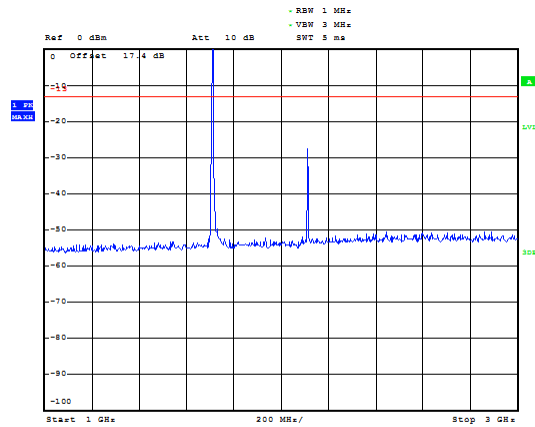

### LTE Band 4 1.4MHz CH-High 3GHz~18GHz

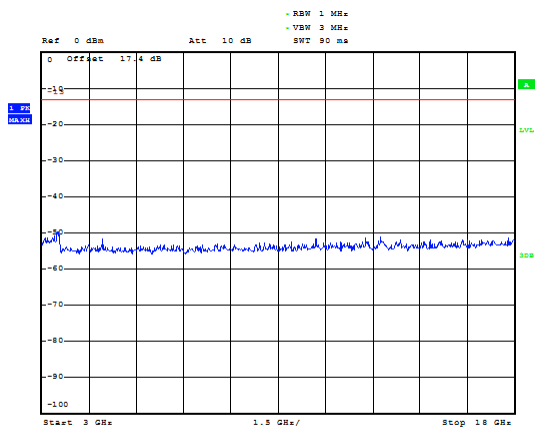

### LTE Band 4 3MHz CH-Low 3GHz~18GHz

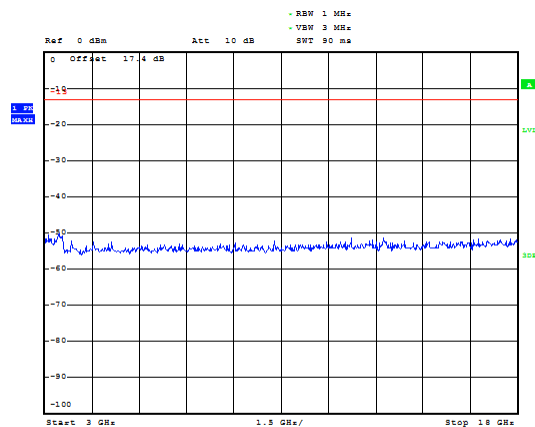



### LTE Band 4 3MHz CH-Middle 30MHz~1GHz

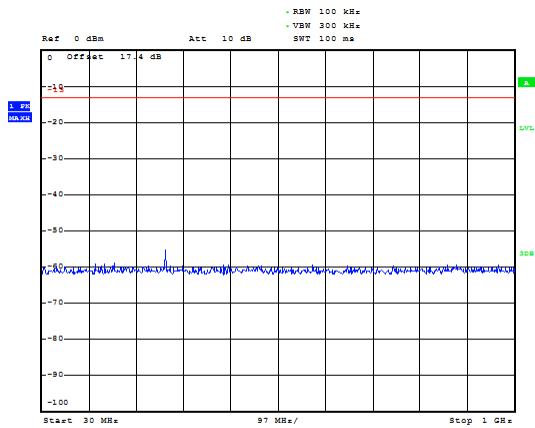

### LTE Band 4 3MHz CH-High 30MHz~1GHz

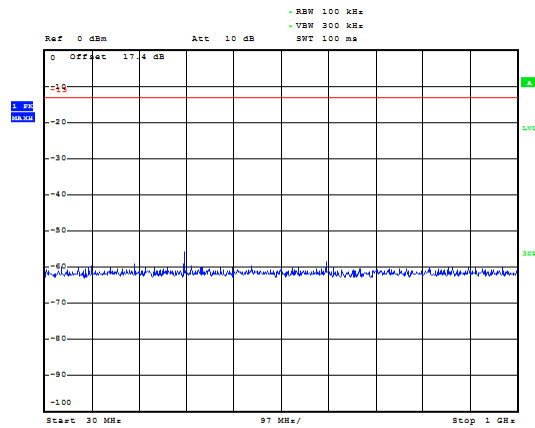

### LTE Band 4 3MHz CH-Middle 1GHz~3GHz

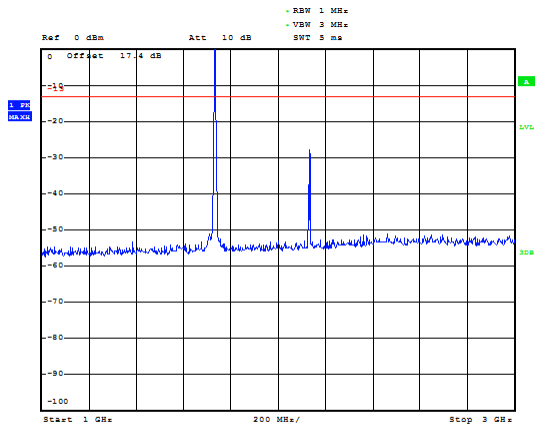

### LTE Band 4 3MHz CH-High 1GHz~3GHz

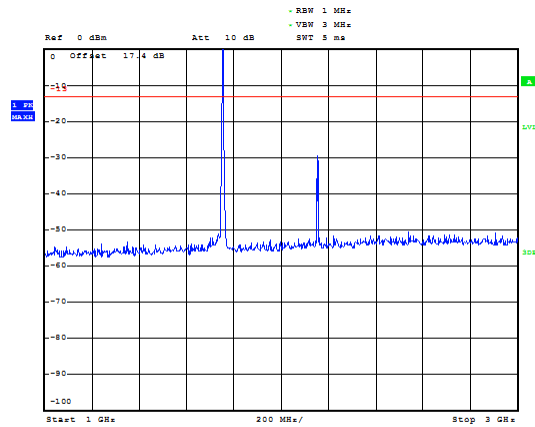

### LTE Band 4 3MHz CH-Middle 3GHz~18GHz

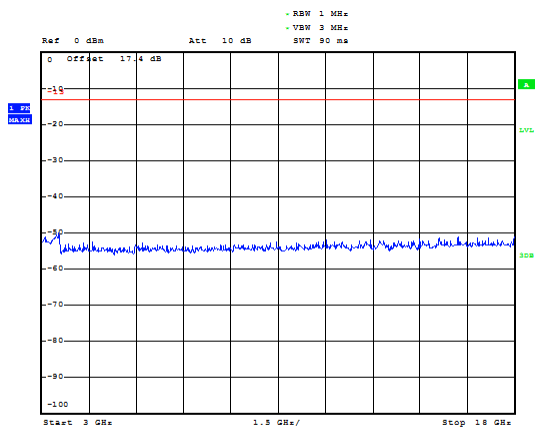

### LTE Band 4 3MHz CH-High 3GHz~18GHz

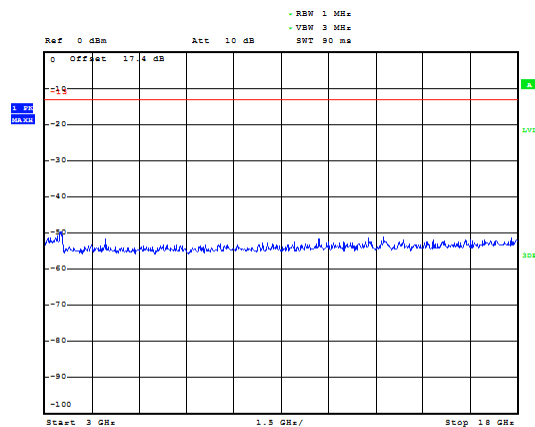



### LTE Band 4 5MHz CH-Low 30MHz~1GHz

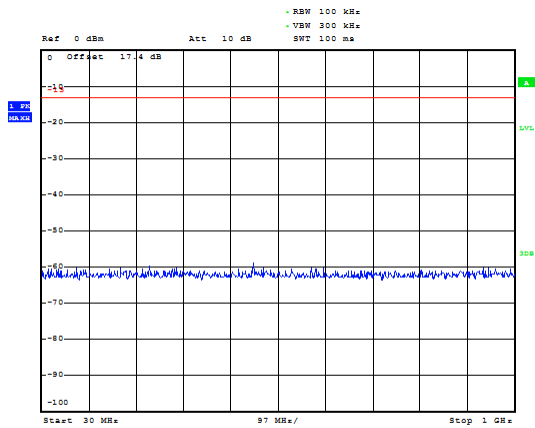

### LTE Band 4 5MHz CH-Middle 30MHz~1GHz

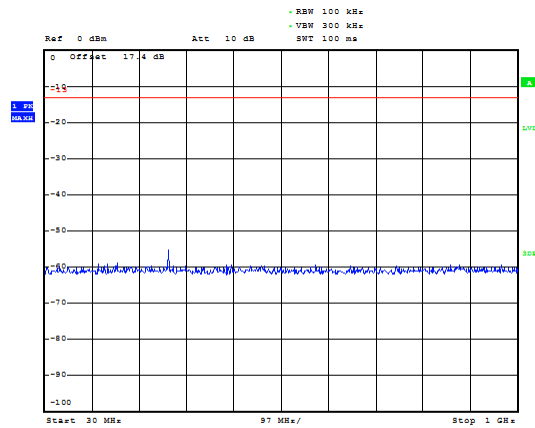

### LTE Band 4 5MHz CH-Low 1GHz~3GHz

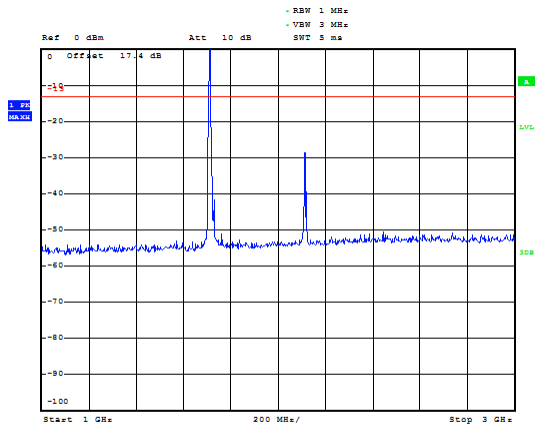

### LTE Band 4 5MHz CH-Middle 1GHz~3GHz

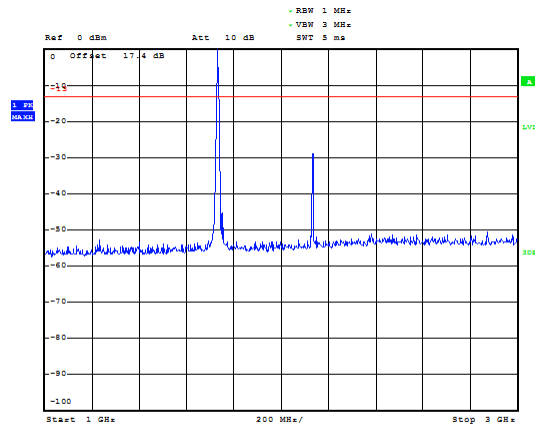

### LTE Band 4 5MHz CH-Low 3GHz~18GHz

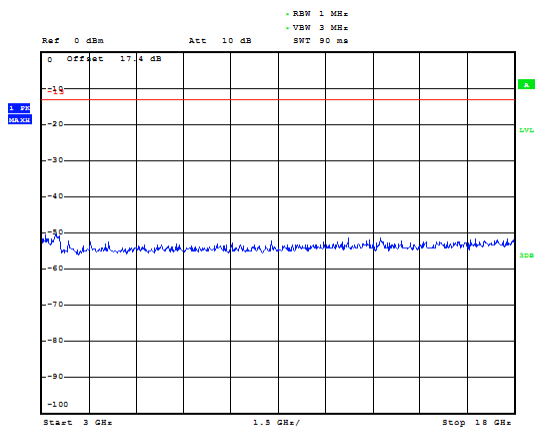

### LTE Band 4 5MHz CH-Middle 3GHz~18GHz

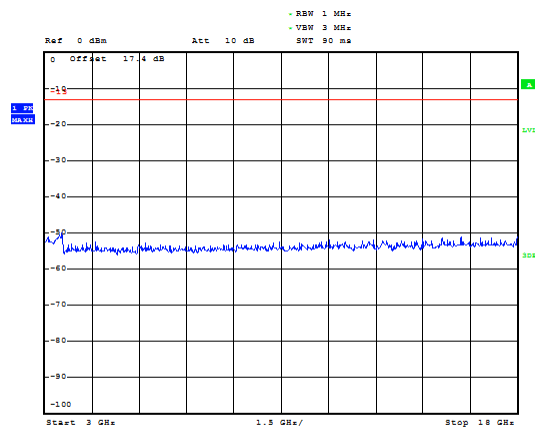





### LTE Band 4 5MHz CH-High 30MHz~1GHz

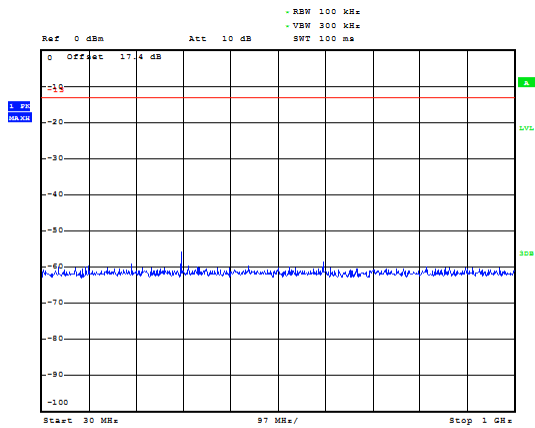

### LTE Band 4 10MHz CH-Low 30MHz~1GHz

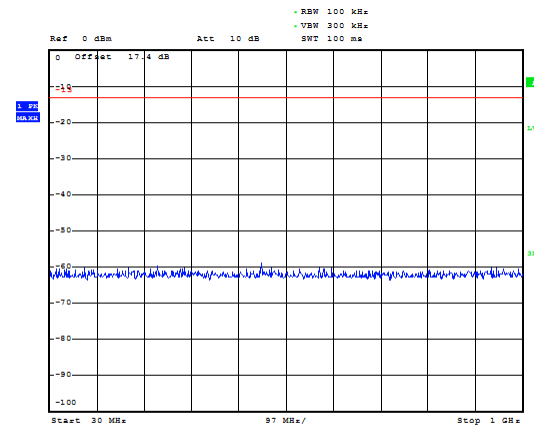

### LTE Band 4 5MHz CH-High 1GHz~3GHz

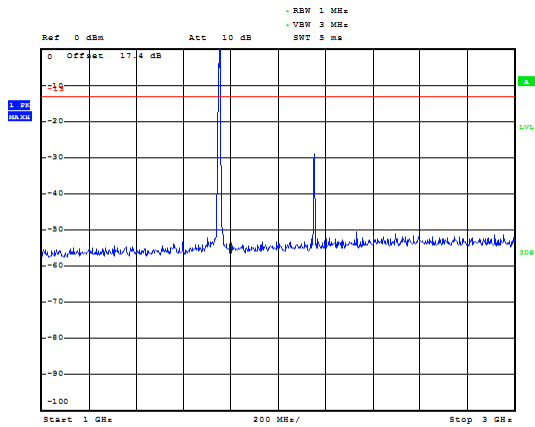

### LTE Band 4 10MHz CH-Low 1GHz~3GHz

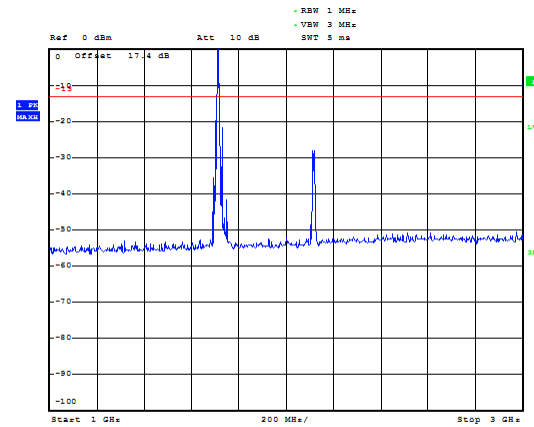

### LTE Band 4 5MHz CH-High 3GHz~18GHz

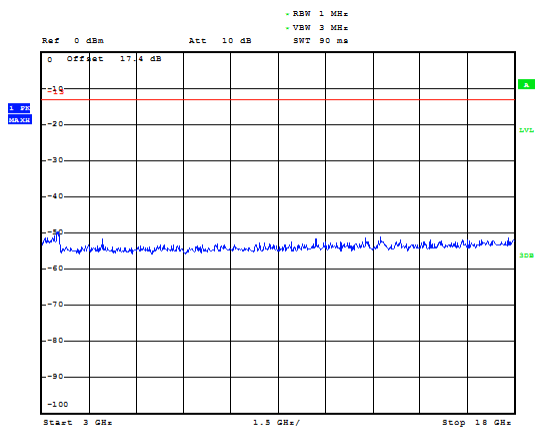

### LTE Band 4 10MHz CH-Low 3GHz~18GHz

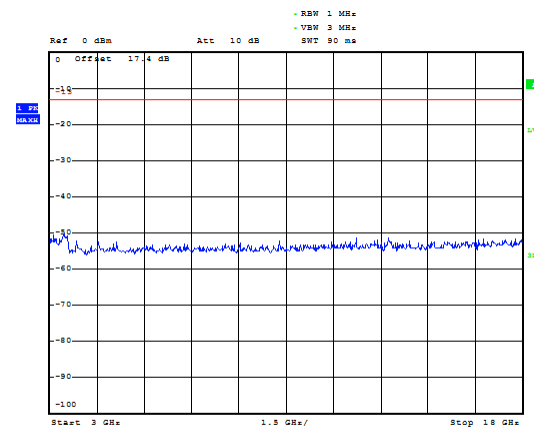



### LTE Band 4 10MHz CH-Middle 30MHz~1GHz

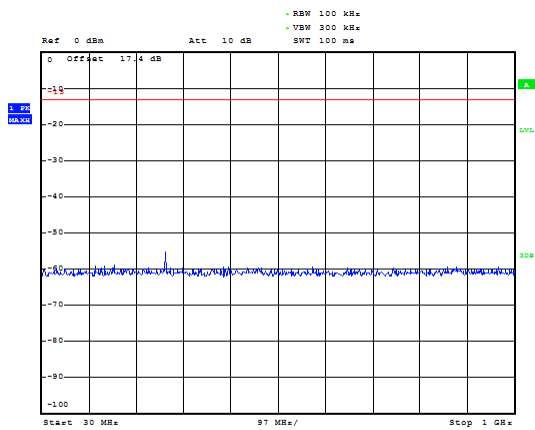

### LTE Band 4 10MHz CH-High 30MHz~1GHz

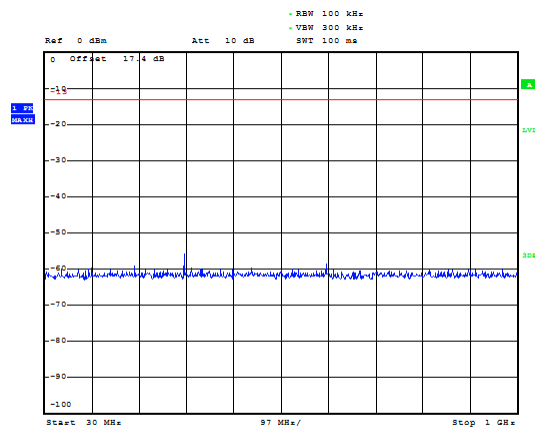

### LTE Band 4 10MHz CH-Middle 1GHz~3GHz

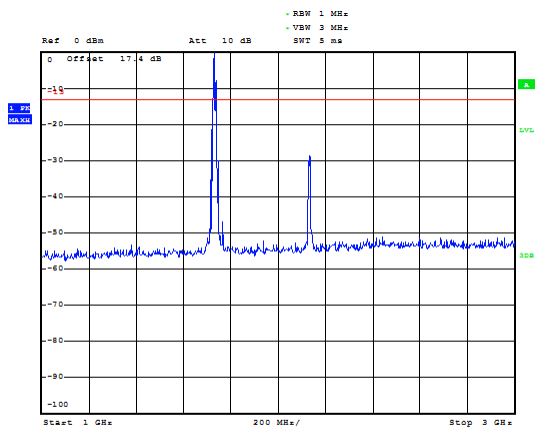

### LTE Band 4 10MHz CH-High 1GHz~3GHz

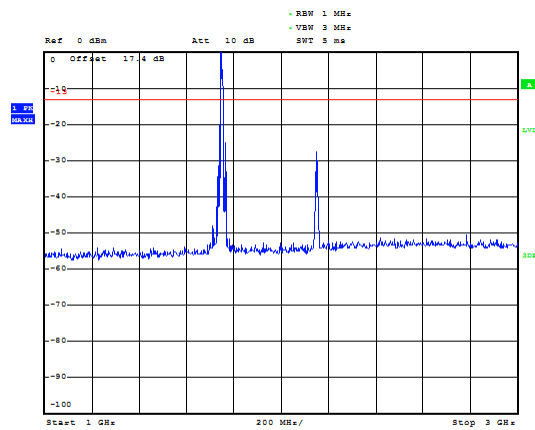

### LTE Band 4 10MHz CH-Middle 3GHz~18GHz

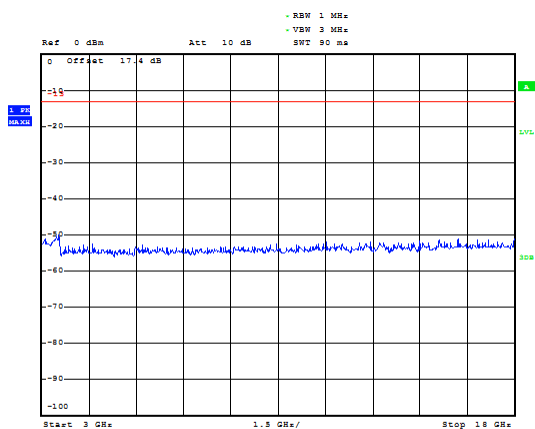

### LTE Band 4 10MHz CH-High 3GHz~18GHz

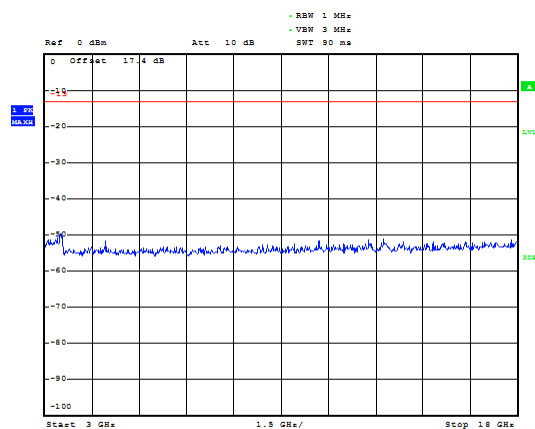



### LTE Band 4 15MHz CH-Low 30MHz~1GHz

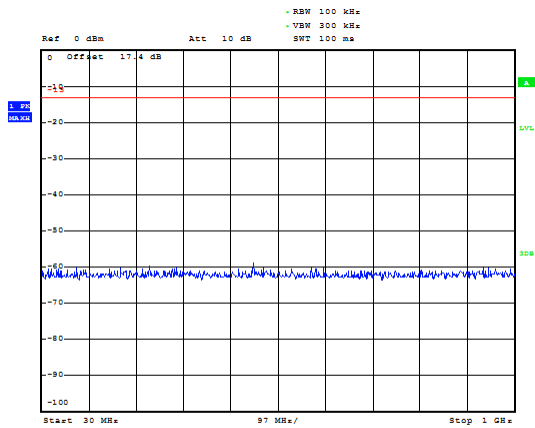

### LTE Band 4 15MHz CH-Middle 30MHz~1GHz

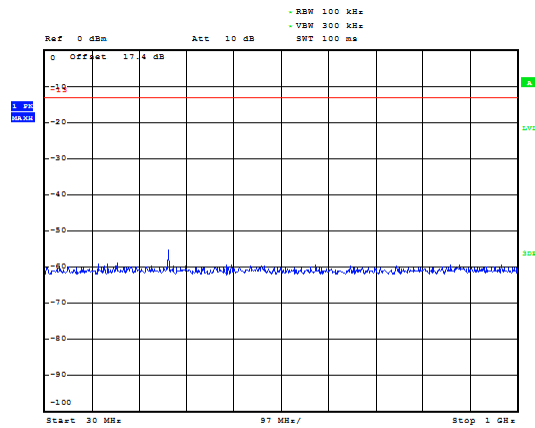

### LTE Band 4 15MHz CH-Low 1GHz~3GHz

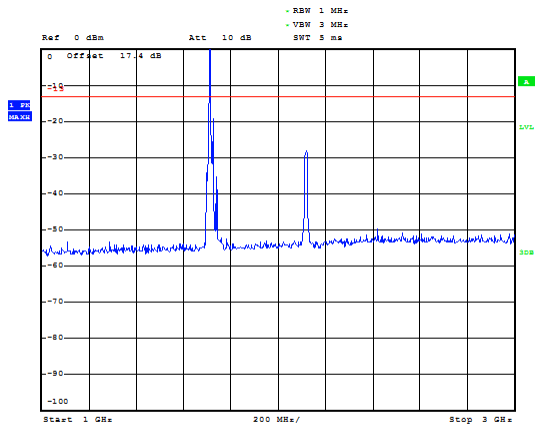

### LTE Band 4 15MHz CH-Middle 1GHz~3GHz

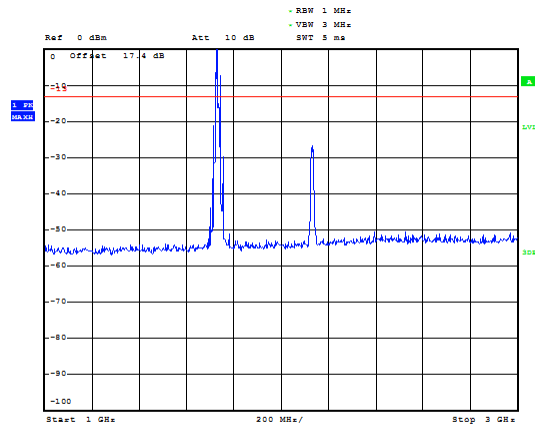

### LTE Band 4 15MHz CH-Low 3GHz~18GHz

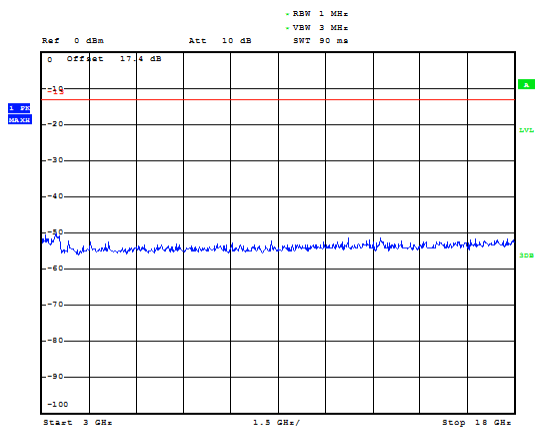

### LTE Band 4 15MHz CH-Middle 3GHz~18GHz

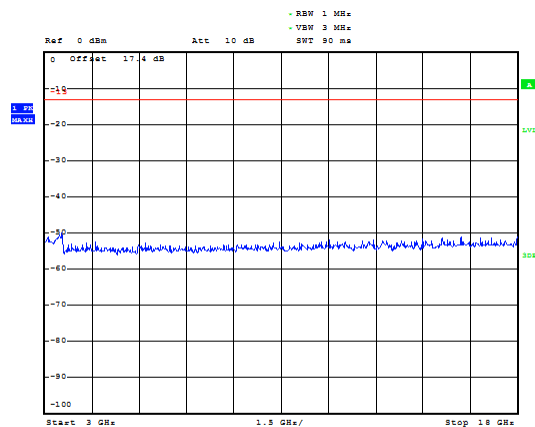



LTE Band 4 15MHz CH-High 30MHz~1GHz

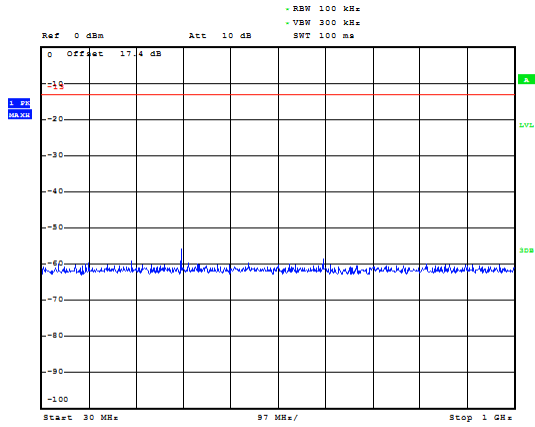

LTE Band 4 20MHz CH-Low 30MHz~1GHz

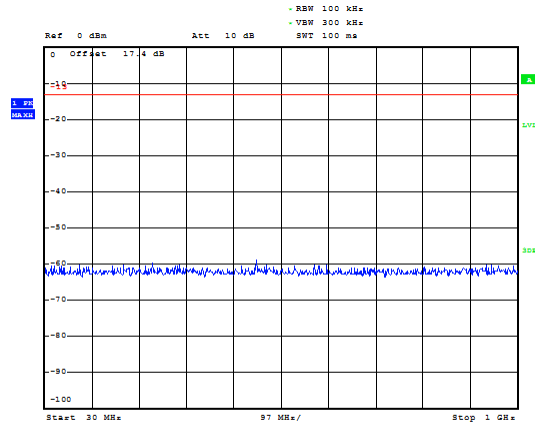

LTE Band 4 15MHz CH-High 1GHz~3GHz

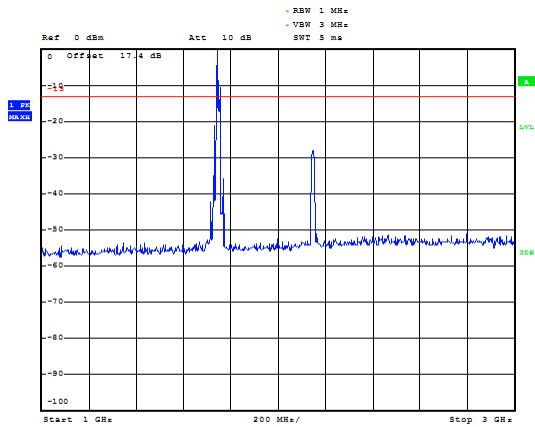

LTE Band 4 20MHz CH-Low 1GHz~3GHz

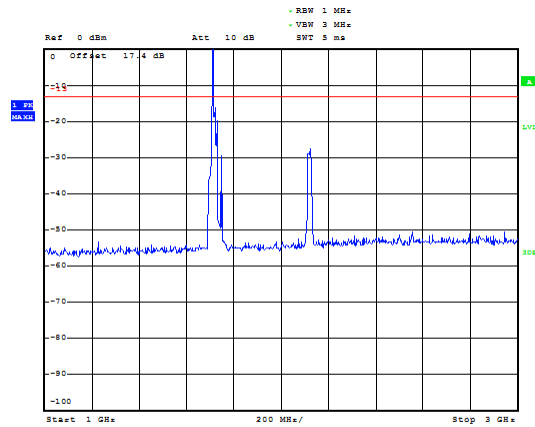

LTE Band 4 15MHz CH-High 3GHz~18GHz

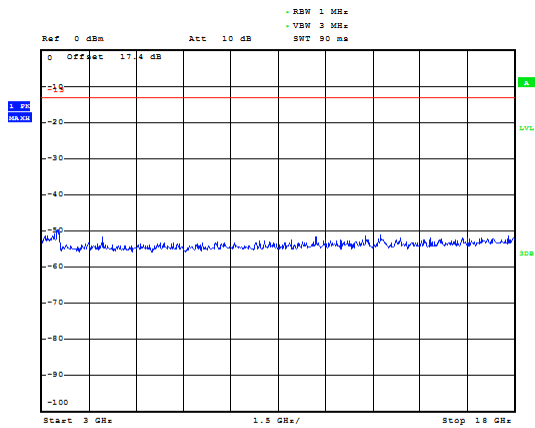

LTE Band 4 20MHz CH-Low 3GHz~18GHz

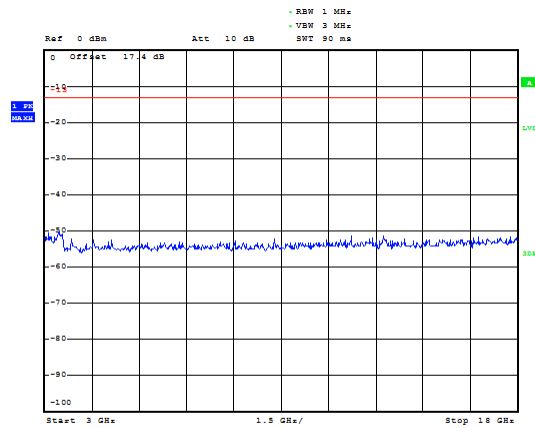



LTE Band 4 20MHz CH- Middle 30MHz~1GHz

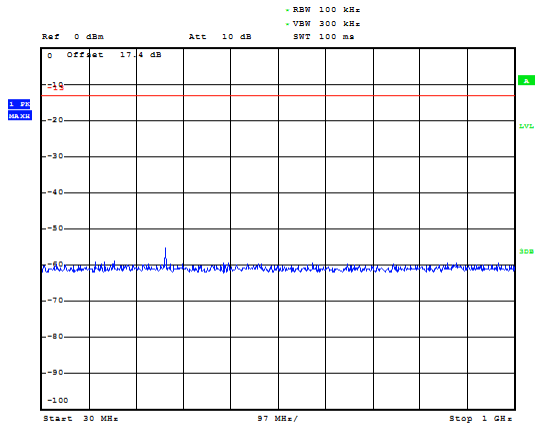

LTE Band 4 20MHz CH- High 30MHz~1GHz

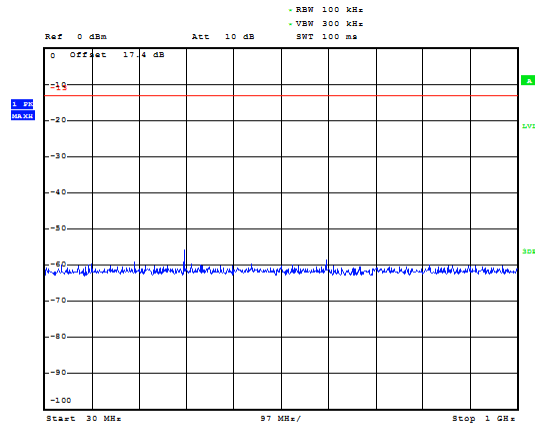

LTE Band 4 20MHz CH- Middle 1GHz~3GHz

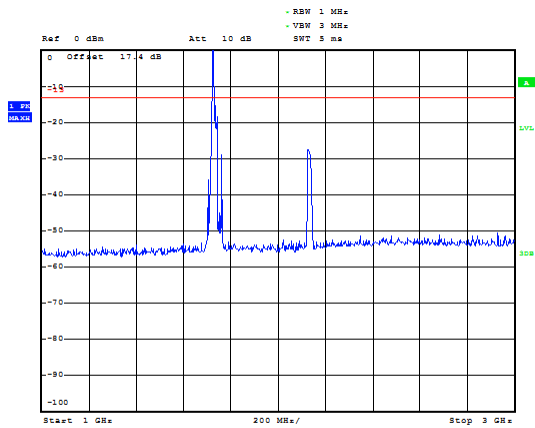

LTE Band 4 20MHz CH- High 1GHz~3GHz

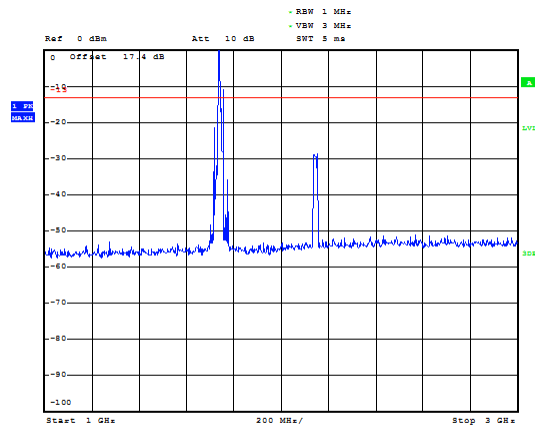

LTE Band 4 20MHz CH- Middle 3GHz~18GHz

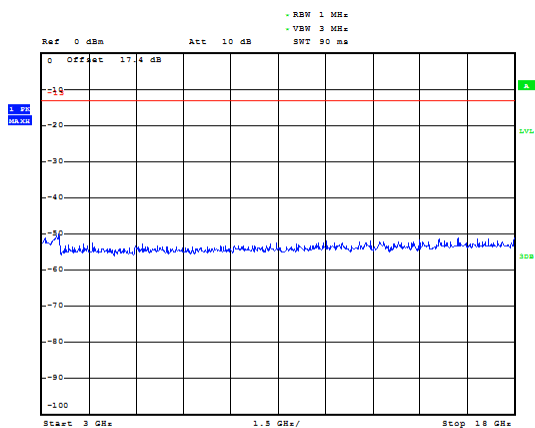

LTE Band 4 20MHz CH- High 3GHz~18GHz

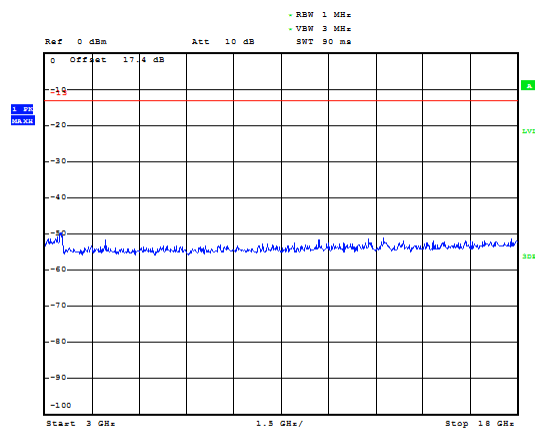



### LTE Band 7 5MHz CH-Low 30MHz~1GHz

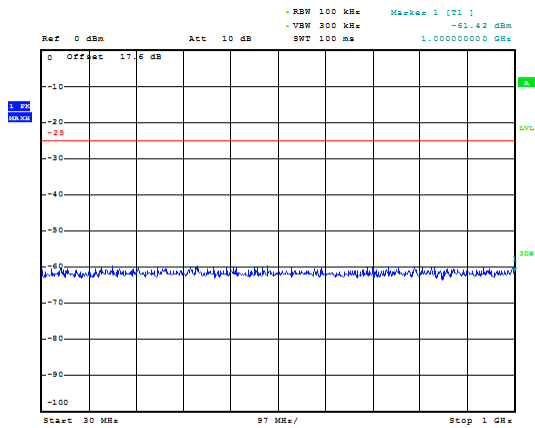

### LTE Band 7 5MHz CH-Middle 30MHz~1GHz

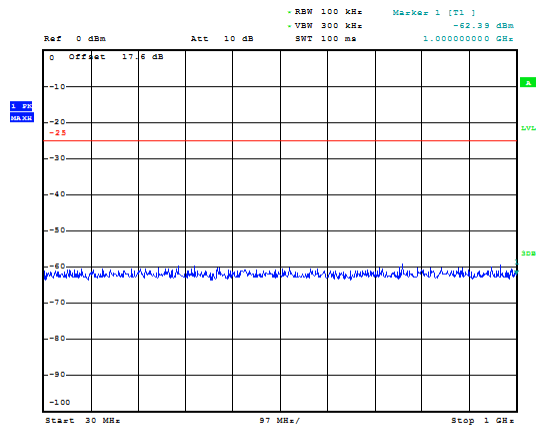

### LTE Band 7 5MHz CH-Low 1GHz~3GHz

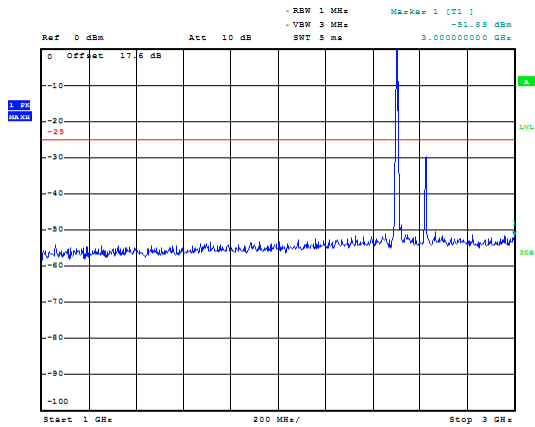

### LTE Band 7 5MHz CH-Middle 1GHz~3GHz

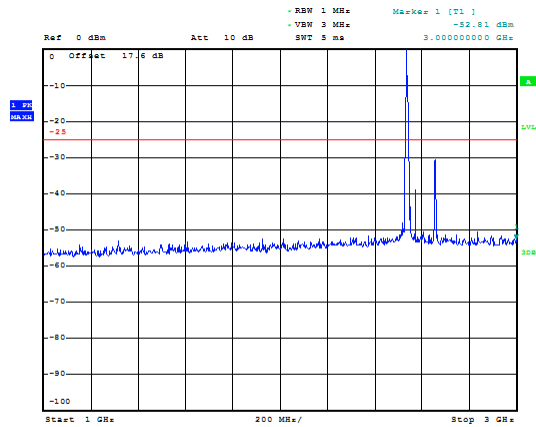

### LTE Band 7 5MHz CH-Low 3GHz~26GHz

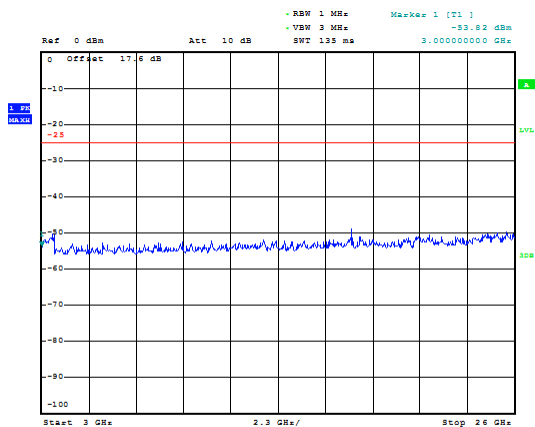

### LTE Band 7 5MHz CH-Middle 3GHz~26GHz

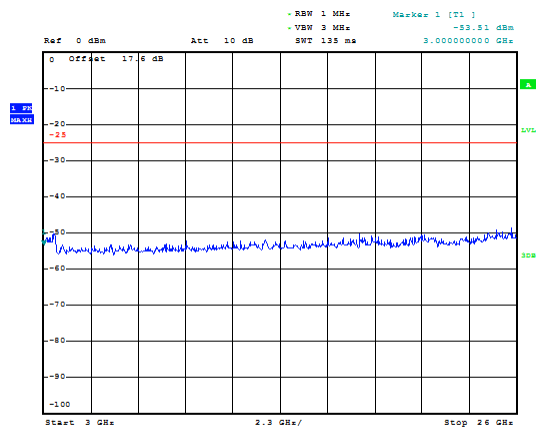



### LTE Band 7 5MHz CH-High 30MHz~1GHz

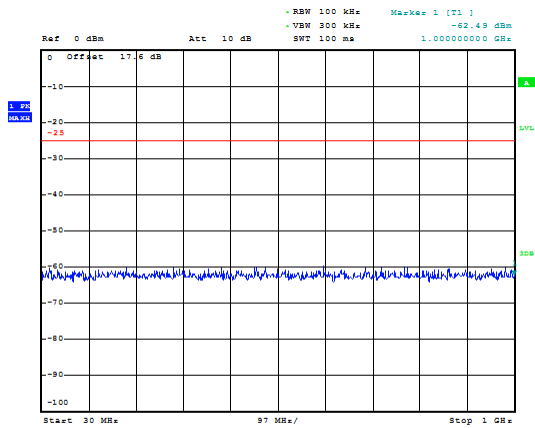

### LTE Band 7 10MHz CH-Low 30MHz~1GHz

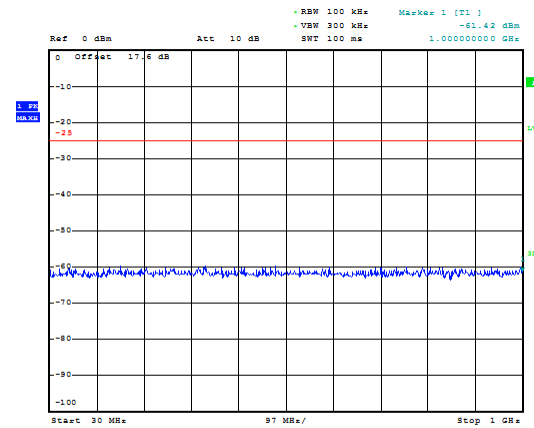

### LTE Band 7 5MHz CH-High 1GHz~3GHz

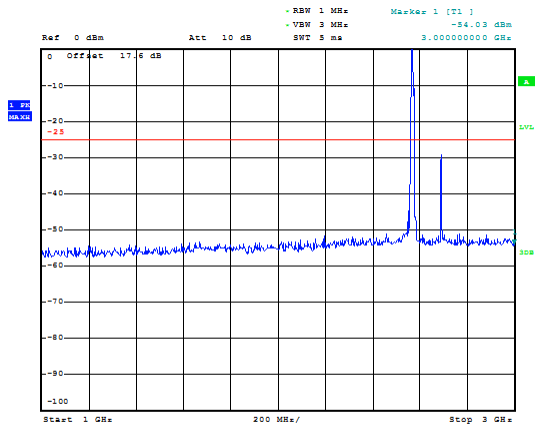

### LTE Band 7 10MHz CH-Low 1GHz~3GHz

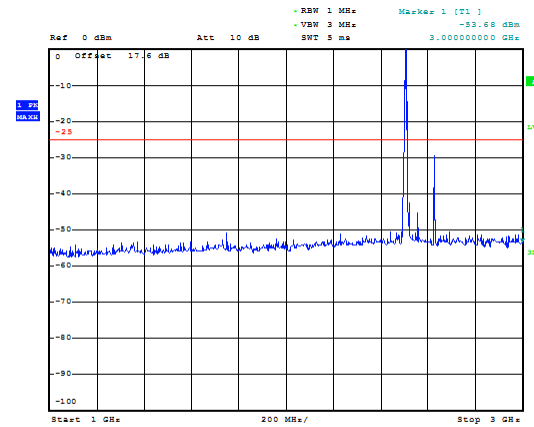

### LTE Band 7 5MHz CH-High 3GHz~26GHz

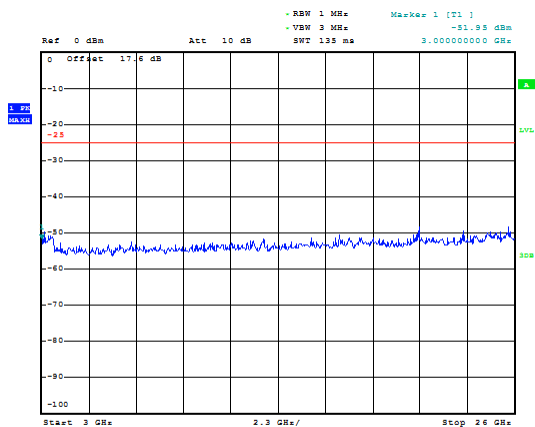

### LTE Band 7 10MHz CH-Low 3GHz~26GHz

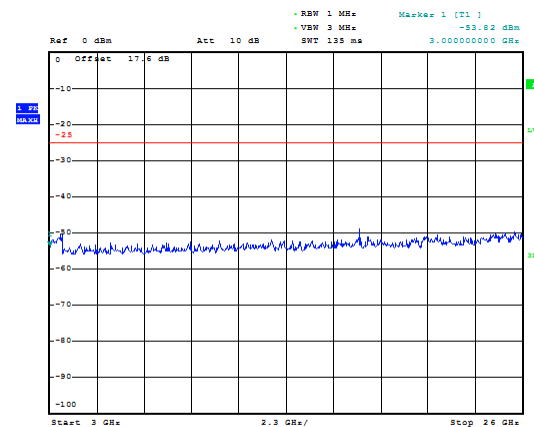





### LTE Band 7 10MHz CH-Middle 30MHz~1GHz

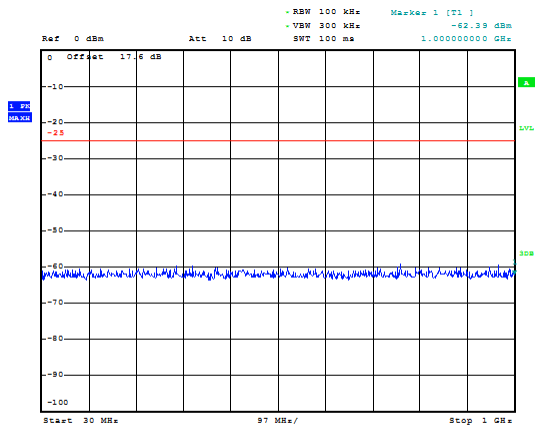

### LTE Band 7 10MHz CH-High 30MHz~1GHz

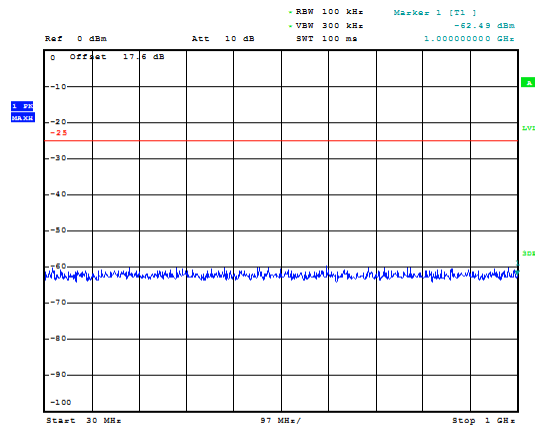

### LTE Band 7 10MHz CH-Middle 1GHz~3GHz

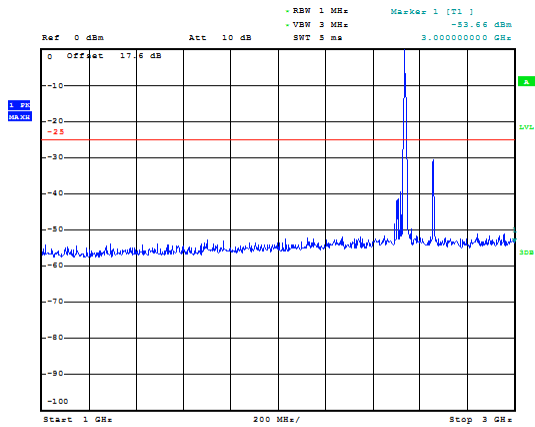

### LTE Band 7 10MHz CH-High 1GHz~3GHz

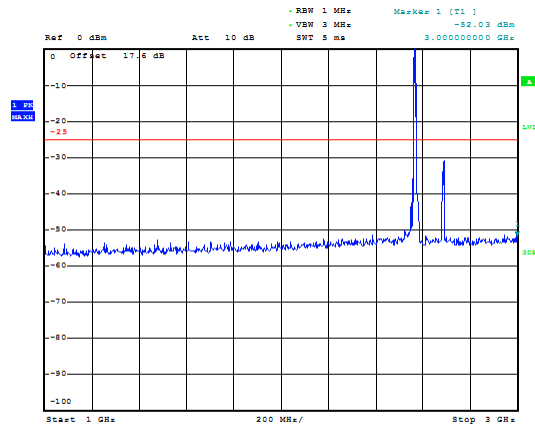

### LTE Band 7 10MHz CH-Middle 3GHz~26GHz

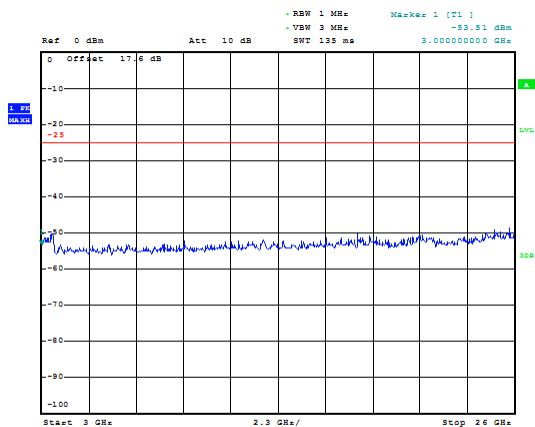

### LTE Band 7 10MHz CH-High 3GHz~26GHz

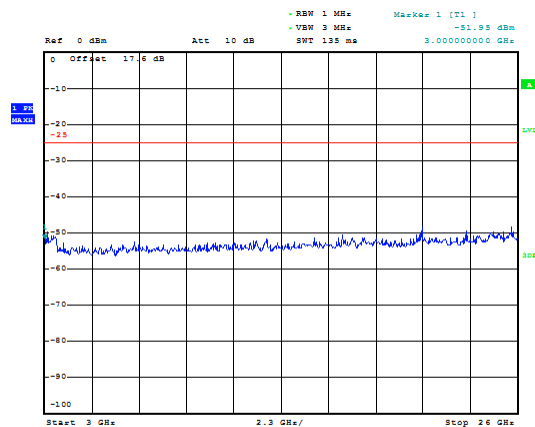



### LTE Band 7 15MHz CH-Low 30MHz~1GHz

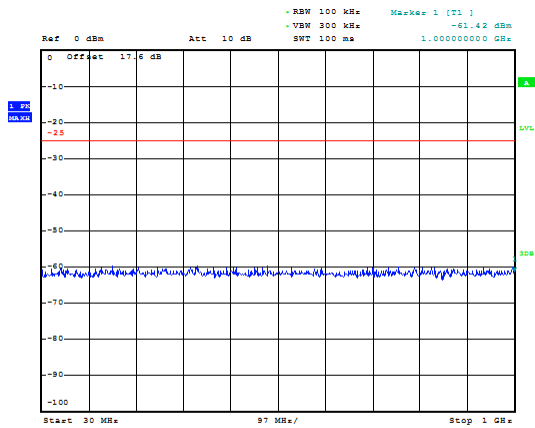

### LTE Band 7 15MHz CH-Middle 30MHz~1GHz

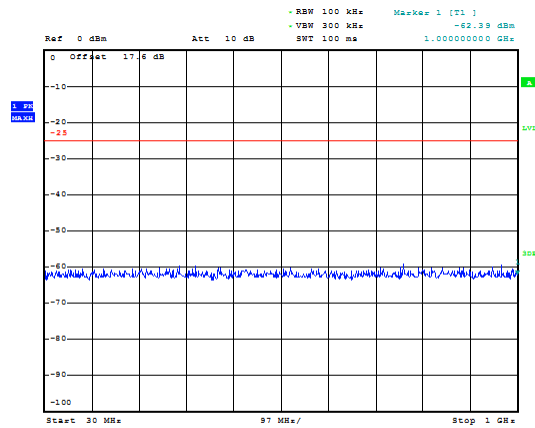

### LTE Band 7 15MHz CH-Low 1GHz~3GHz

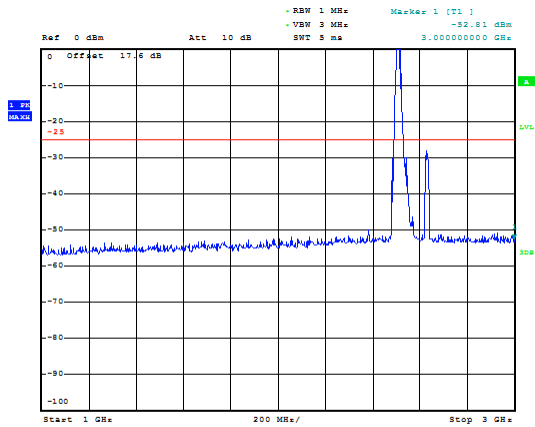

### LTE Band 7 15MHz CH-Middle 1GHz~3GHz

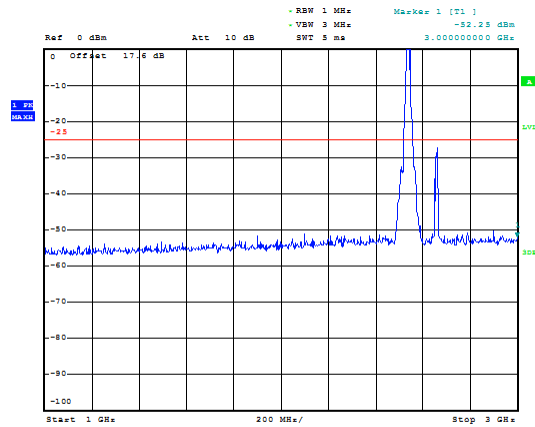

### LTE Band 7 15MHz CH-Low 3GHz~26GHz

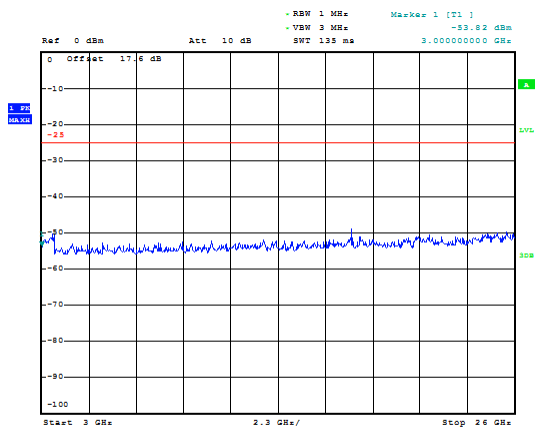

### LTE Band 7 15MHz CH-Middle 3GHz~26GHz

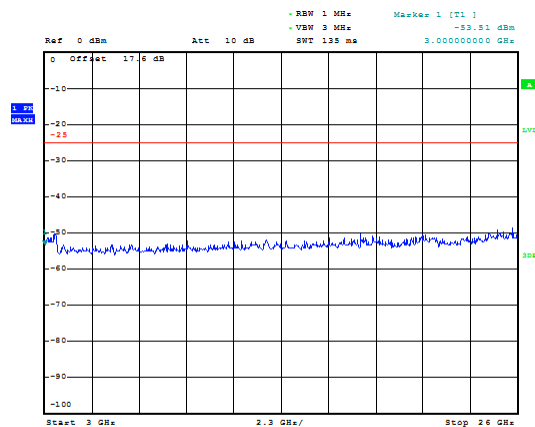



### LTE Band 7 15MHz CH-High 30MHz~1GHz

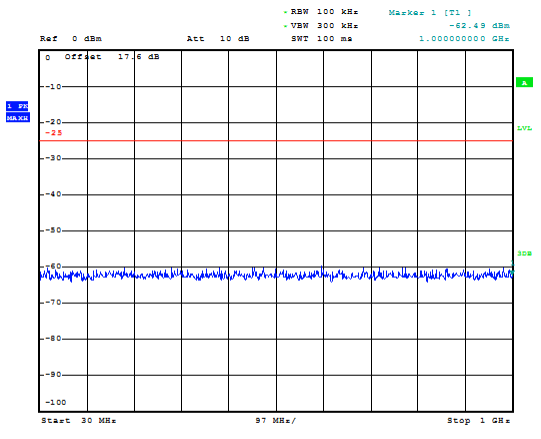

### LTE Band 7 20MHz CH-Low 30MHz~1GHz

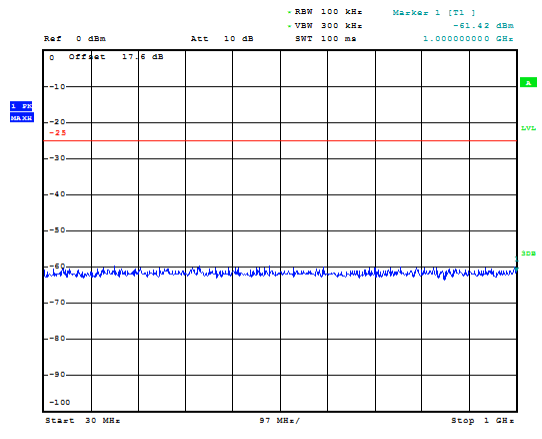

### LTE Band 7 15MHz CH-High 1GHz~3GHz

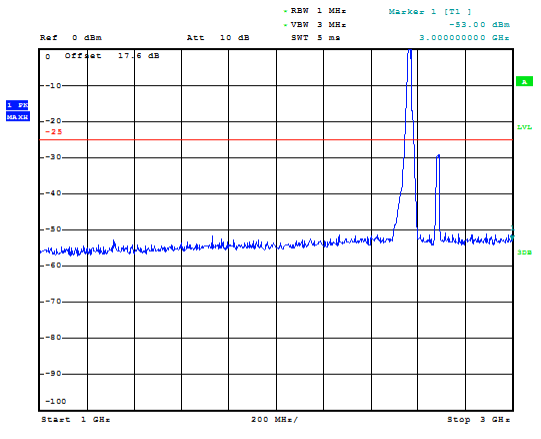

### LTE Band 7 20MHz CH-Low 1GHz~3GHz

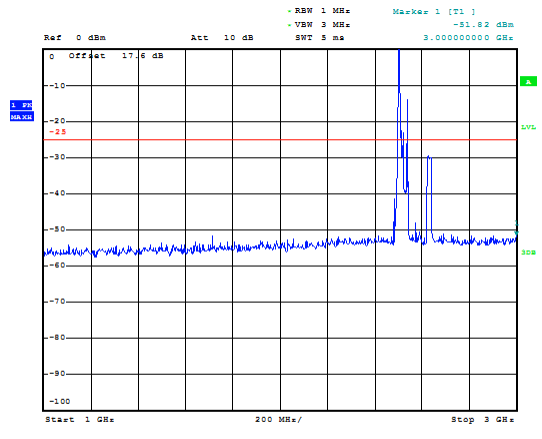

### LTE Band 7 15MHz CH-High 3GHz~26GHz

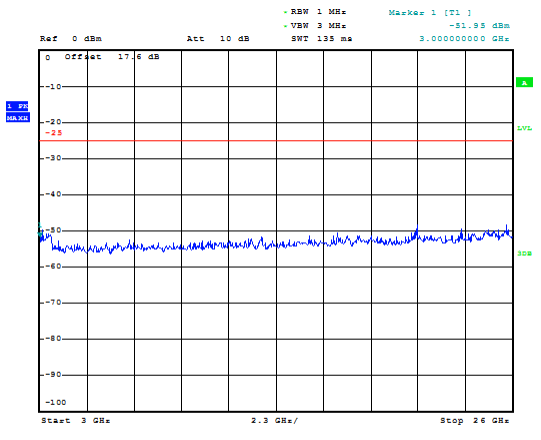

### LTE Band 7 20MHz CH-Low 3GHz~26GHz

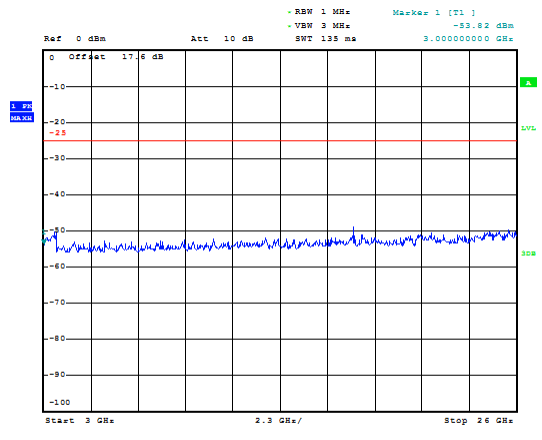



### LTE Band 7 20MHz CH-Middle 30MHz~1GHz

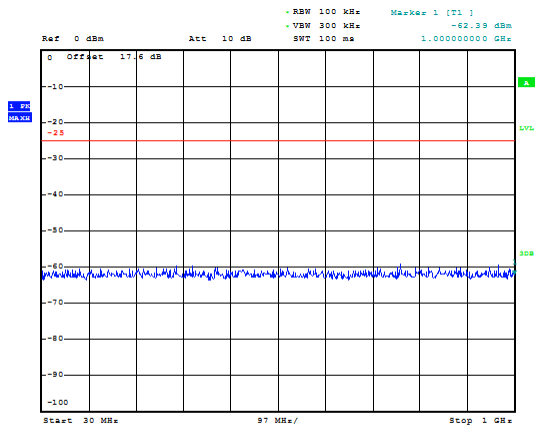

### LTE Band 7 20MHz CH-High 30MHz~1GHz

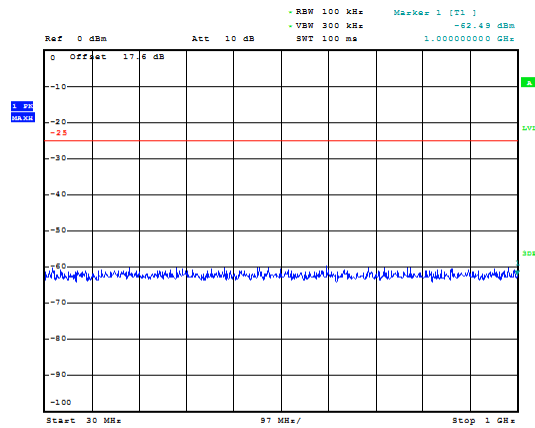

### LTE Band 7 20MHz CH-Middle 1GHz~3GHz

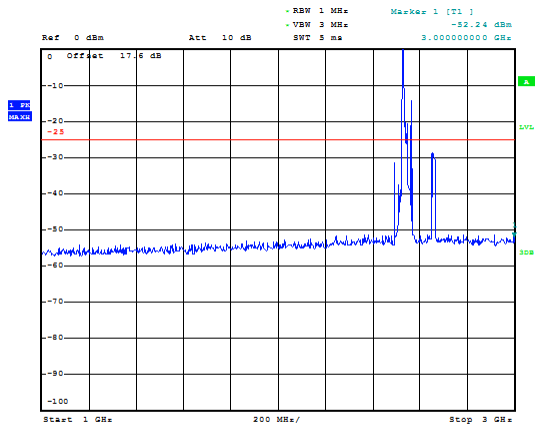

### LTE Band 7 20MHz CH-High 1GHz~3GHz

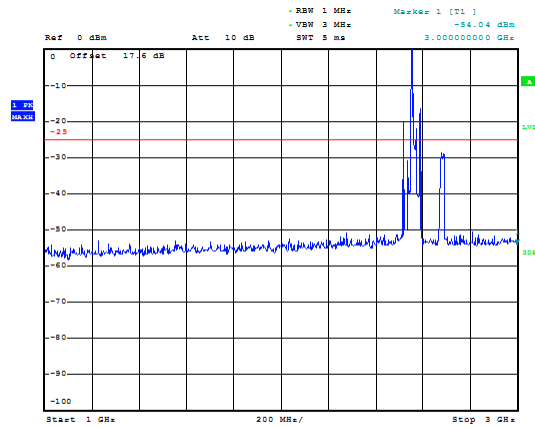

### LTE Band 7 20MHz CH-Middle 3GHz~26GHz

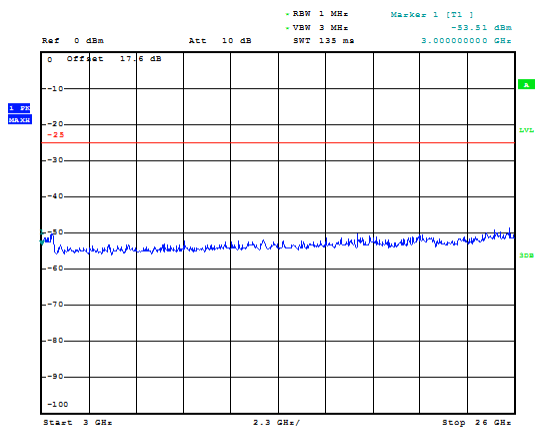

### LTE Band 7 20MHz CH-High 3GHz~26GHz

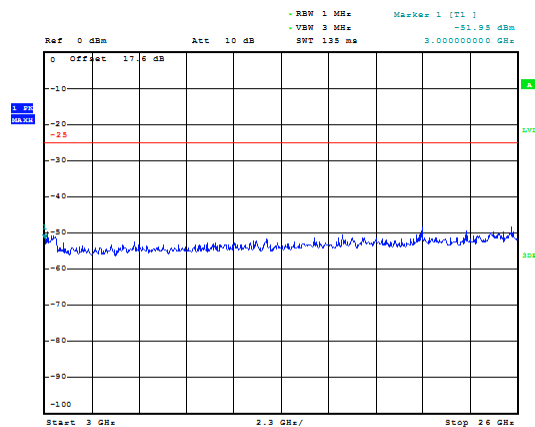

## 5.7 Radiates Spurious Emission

### Ambient condition

Temperature	Relative humidity	Pressure
23°C ~25°C	45%~50%	101.5kPa

### Method of Measurement

- The testing follows FCC KDB 971168 D01 v03r01 Section 5.8 and ANSI C63.26 (2015).
- Below 1GHz: The EUT is placed on a turntable 0.8 meters above the ground in the chamber, 3 meter away from the antenna. The maximal emission value is acquired by adjusting the antenna height, polarisation and turntable azimuth. Normally, the height range of antenna is 1 m to 4 m, the azimuth range of turntable is 0° to 360°, and the receive antenna has two polarizations Vertical (V) and Horizontal (H). Above 1GHz: (Note: the FCC's permission to use 1.5m as an alternative per TCBC Conf call of Dec. 2, 2014.) The EUT is placed on a turntable 1.5 meters above the ground in the chamber, 3 meter away from the antenna. The maximal emission value is acquired by adjusting the antenna height, polarisation and turntable azimuth. Normally, the height range of antenna is 1 m to 4 m, the azimuth range of turntable is 0° to 360°, and the receive antenna has two polarizations Vertical (V) and Horizontal (H).
- A loop antenna, A log-periodic antenna or horn antenna shall be substituted in place of the EUT. The log-periodic antenna will be driven by a signal generator and the level will be adjusted till the same power value on the spectrum analyzer or receiver. The level of the spurious emissions can be calculated through the level of the signal generator, cable loss, the gain of the substitution antenna and the reading of the spectrum analyzer or receiver.
- The EUT is then put into continuously transmitting mode at its maximum power level during the test. Set Test Receiver or Spectrum RBW=100kHz, VBW=300kHz for 30MHz to 1GHz and RBW=1MHz, VBW=3MHz for above 1GHz, and the maximum value of the receiver should be recorded as (Pr).
- The EUT shall be replaced by a substitution antenna. In the chamber, an substitution antenna for the frequency band of interest is placed at the reference point of the chamber. An RF Signal source for the frequency band of interest is connected to the substitution antenna with a cable that has been constructed to not interfere with the radiation pattern of the antenna. A power (PMea) is applied to the input of the substitution antenna, and adjust the level of the signal generator output until the value of the receiver reach the previously recorded (Pr). The power of signal source (PMea) is recorded. The test should be performed by rotating the test item and adjusting the receiving antenna polarization.
- A amplifier should be connected to the Signal Source output port. And the cable should be connect between the Amplifier and the Substitution Antenna. The cable loss (Pcl) ,the Substitution Antenna Gain (Ga) and the Amplifier Gain (PAG) should be recorded after test.
- The measurement results are obtained as described below:  
 $Power(EIRP)=PMea- PAg - Pcl + Ga$   
 The measurement results are amend as described below:  
 $Power(EIRP)=PMea- Pcl + Ga$
- This value is EIRP since the measurement is calibrated using an antenna of known gain (2.15 dBi) and known input power. ERP can be calculated from EIRP by subtracting the gain of the dipole,  $ERP = EIRP-2.15dBi$ .

The modulation mode and RB allocation refer to section 5.1, using the maximum output power configuration.

**Test setup**

**9KHz ~ 30MHz**

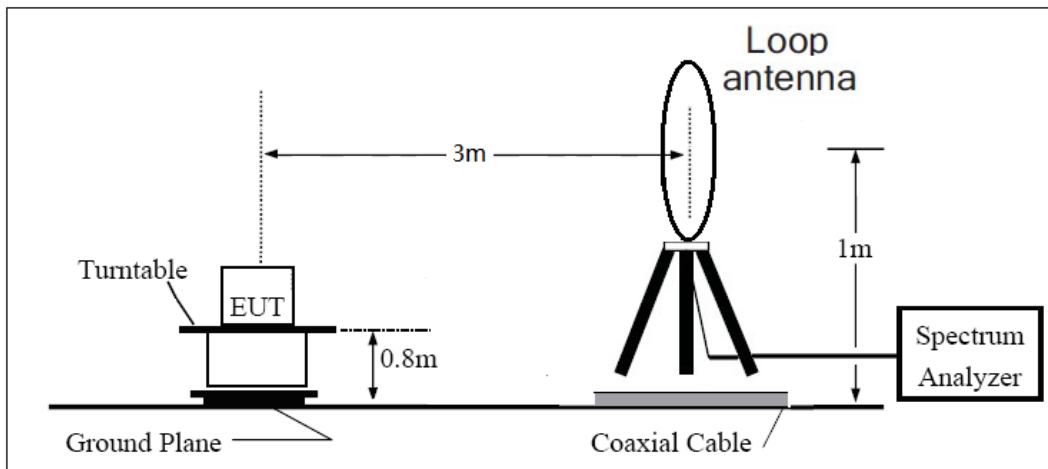

**30MHz ~ 1GHz**

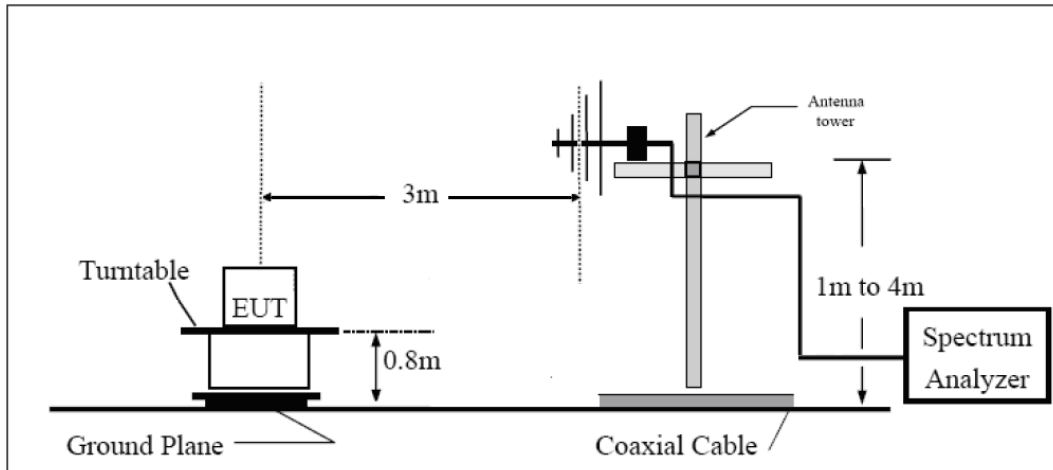

**Above 1GHz**

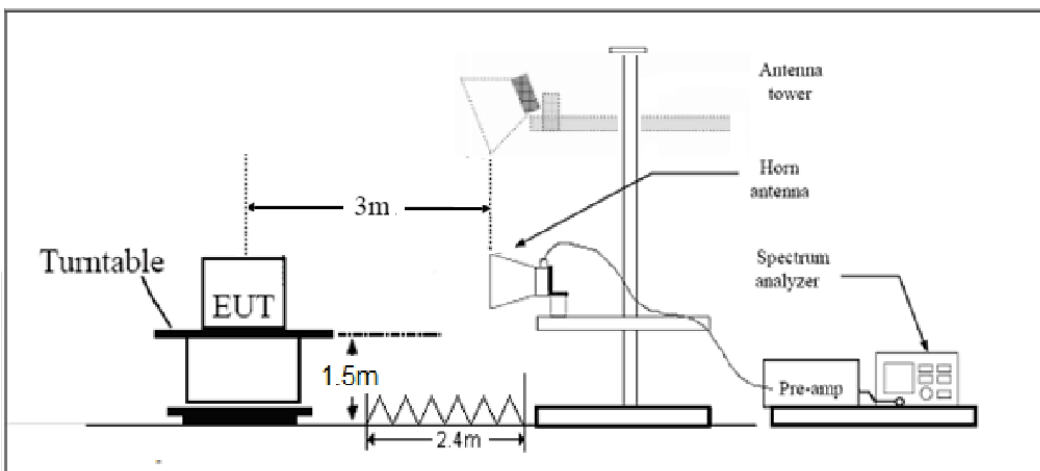

Note: Area side:2.4mX3.6m



## Limits

Rule Part 27.53(h) specifies that “for operations in the 1695-1710 MHz, 1710-1755 MHz, 1755-1780 MHz, 1915-1920 MHz, 1995-2000 MHz, 2000-2020 MHz, 2110-2155 MHz, 2155-2180 MHz, and 2180-2200 bands, the power of any emission outside a licensee's frequency block shall be attenuated below the transmitter power (P) in watts by at least  $43 + 10 \log_{10} (P)$  dB.”

Rule Part 27.53(m)  $55 + 10 \log (P)$  dB on all frequencies more than X megahertz from the channel edge, where X is the greater of 6 megahertz or the actual emission bandwidth as defined in paragraph (m)(4) of this section.

Part 27.53(a)/(h)/(g) Limit	-13 dBm
Part 27.53(m) Limit	-25 dBm

## Measurement Uncertainty

The assessed measurement uncertainty to ensure 95% confidence level for the normal distribution is with the coverage factor  $k = \pm 1.96$ ,  $U = \pm 3.55$  dB.



**Test Result**

Sweep the whole frequency band through the range from 9kHz to the 10th harmonic of the carrier, the emissions below the noise floor will not be recorded in the report.

LTE Band 4 QPSK 1.4MHz CH-Middle, RB 1

Harmonic	Frequency (MHz)	SG (dBm)	Cable Loss (dB)	Gain (dBi)	Antenna Polarization	EIRP Level (dBm)	Limit (dBm)	Margin (dB)	Azimuth (deg)
2	3464.3	-52.35	2.6	10.75	Horizontal	-44.20	-13.00	31.20	315
3	5197.5	-53.56	2.4	11.05	Horizontal	-44.91	-13.00	31.91	270
4	6930.8	-57.19	4.5	11.15	Horizontal	-50.54	-13.00	37.54	225
5	8664.0	-54.13	5.1	11.35	Horizontal	-47.88	-13.00	34.88	180
6	10397.3	-49.24	5.3	11.95	Horizontal	-42.59	-13.00	29.59	90
7	12130.5	-51.16	5.5	13.55	Horizontal	-43.11	-13.00	30.11	315
8	13863.8	-49.99	6.3	13.75	Horizontal	-42.54	-13.00	29.54	0
9	15597.0	-49.17	6.7	13.85	Horizontal	-42.02	-13.00	29.02	135
10	17330.3	-47.66	6.8	14.25	Horizontal	-40.21	-13.00	27.21	270

Note: 1.The other Spurious RF Radiated emissions level is no more than noise floor.

2. The worst emission was found in the antenna is Horizontal position.

LTE Band 4 QPSK 5MHz CH-Middle, RB 1

Harmonic	Frequency (MHz)	SG (dBm)	Cable Loss (dB)	Gain (dBi)	Antenna Polarization	EIRP Level (dBm)	Limit (dBm)	Margin (dB)	Azimuth (deg)
2	3460.5	-51.66	2.6	10.75	Horizontal	-43.51	-13.00	30.51	90
3	5191.5	-54.73	2.4	11.05	Horizontal	-46.08	-13.00	33.08	315
4	6922.5	-55.43	4.5	11.15	Horizontal	-48.78	-13.00	35.78	225
5	8653.5	-55.08	5.1	11.35	Horizontal	-48.83	-13.00	35.83	135
6	10384.5	-50.13	5.3	11.95	Horizontal	-43.48	-13.00	30.48	45
7	12115.5	-51.14	5.5	13.55	Horizontal	-43.09	-13.00	30.09	90
8	13846.5	-50.84	6.3	13.75	Horizontal	-43.39	-13.00	30.39	315
9	15577.5	-49.63	6.7	13.85	Horizontal	-42.48	-13.00	29.48	180
10	17308.5	-47.87	6.8	14.25	Horizontal	-40.42	-13.00	27.42	135

Note: 1.The other Spurious RF Radiated emissions level is no more than noise floor.

2. The worst emission was found in the antenna is Horizontal position.



## LTE Band 4 QPSK 20MHz CH-Middle, RB 1

Harmonic	Frequency (MHz)	SG (dBm)	Cable Loss (dB)	Gain (dBi)	Antenna Polarization	EIRP Level (dBm)	Limit (dBm)	Margin (dB)	Azimuth (deg)
2	3447.0	-55.23	2.6	10.75	Horizontal	-47.08	-13.00	34.08	270
3	5170.9	-56.27	2.4	11.05	Horizontal	-47.62	-13.00	34.62	180
4	6894.8	-59.94	4.5	11.15	Horizontal	-53.29	-13.00	40.29	315
5	8618.6	-54.97	5.1	11.35	Horizontal	-48.72	-13.00	35.72	180
6	10342.5	-50.57	5.3	11.95	Horizontal	-43.92	-13.00	30.92	135
7	12066.4	-51.66	5.5	13.55	Horizontal	-43.61	-13.00	30.61	90
8	13790.3	-49.74	6.3	13.75	Horizontal	-42.29	-13.00	29.29	45
9	15514.1	-49.23	6.7	13.85	Horizontal	-42.08	-13.00	29.08	270
10	17238.0	-47.06	6.8	14.25	Horizontal	-39.61	-13.00	26.61	0

Note: 1.The other Spurious RF Radiated emissions level is no more than noise floor.

2. The worst emission was found in the antenna is Horizontal position.

## LTE Band 7 QPSK 5MHz CH-Middle, RB 1

Harmonic	Frequency (MHz)	SG (dBm)	Cable Loss (dB)	Gain (dBi)	Antenna Polarization	EIRP Level (dBm)	Limit (dBm)	Margin (dB)	Azimuth (deg)
2	5065.8	-49.83	2.00	9.15	Horizontal	-42.68	-25.00	17.68	135
3	7598.6	-53.30	2.50	11.35	Horizontal	-44.45	-25.00	19.45	180
4	10130.6	-47.91	4.20	12.05	Horizontal	-40.06	-25.00	15.06	270
5	12675.0	-48.71	5.20	12.85	Horizontal	-41.06	-25.00	16.06	225
6	15210.0	-51.38	5.50	14.23	Horizontal	-42.65	-25.00	17.65	315
7	17745.0	-49.32	5.70	14.15	Horizontal	-40.87	-25.00	15.87	0
8	20280.0	--	--	--	--	--	--	--	--
9	22815.0	--	--	--	--	--	--	--	--
10	25350.0	--	--	--	--	--	--	--	--

Note: 1.The other Spurious RF Radiated emissions level is no more than noise floor.

2. The worst emission was found in the antenna is Horizontal position.



LTE Band 7 QPSK 20MHz CH-Middle, RB 1

Harmonic	Frequency (MHz)	SG (dBm)	Cable Loss (dB)	Gain (dBi)	Antenna Polarization	EIRP Level (dBm)	Limit (dBm)	Margin (dB)	Azimuth (deg)
2	5052.4	-50.86	2.00	10.15	Horizontal	-42.71	-25.00	17.71	135
3	7578.0	-54.16	2.50	11.35	Horizontal	-45.31	-25.00	20.31	270
4	10103.6	-47.81	4.20	12.05	Horizontal	-39.96	-25.00	14.96	90
5	12629.3	-51.36	5.20	14.85	Horizontal	-41.71	-25.00	16.71	45
6	15154.9	-50.41	5.50	13.23	Horizontal	-42.68	-25.00	17.68	180
7	17680.5	-46.44	5.70	12.15	Horizontal	-39.99	-25.00	14.99	45
8	20206.1	--	--	--	--	--	--	--	--
9	22731.8	--	--	--	--	--	--	--	--
10	25257.4	--	--	--	--	--	--	--	--

Note: 1. The other Spurious RF Radiated emissions level is no more than noise floor.

2. The worst emission was found in the antenna is Horizontal position.



## 6 Main Test Instruments

Name	Manufacturer	Type	Serial Number	Calibration Date	Expiration Date
Base Station Simulator	R&S	CMW500	113824	2017-05-21	2018-05-20
Base Station Simulator	R&S	CMW500	113824	2018-05-20	2019-05-19
Base Station Simulator	R&S	CMW500	113824	2019-05-19	2020-05-18
Power Splitter	Hua Xiang	SHX-GF2-2-13	10120101	/	/
Spectrum Analyzer	Key sight	N9010A	MY50210259	2017-05-21	2018-05-20
Spectrum Analyzer	Key sight	N9010A	MY50210259	2018-05-20	2019-05-19
Spectrum Analyzer	Key sight	N9010A	MY50210259	2019-05-19	2020-05-18
Signal Analyzer	R&S	FSV30	100815	2017-12-17	2018-12-16
Signal Analyzer	R&S	FSV30	100815	2018-12-16	2019-12-15
Signal Analyzer	R&S	FSV30	100815	2019-12-15	2020-12-14
Loop Antenna	SCHWARZBECK	FMZB1519	1519-047	2017-09-26	2020-09-25
Trilog Antenna	SCHWARZBECK	VUBL 9163	9163-201	2017-11-18	2020-11-17
Horn Antenna	R&S	HF907	100126	2016-07-08	2018-07-07
Horn Antenna	R&S	HF907	100126	2018-07-07	2020-07-06
Horn Antenna	ETS-Lindgren	3160-09	00102643	2016-06-21	2018-06-20
Horn Antenna	ETS-Lindgren	3160-09	00102643	2018-06-20	2020-06-19
Signal generator	R&S	SMB 100A	102594	2017-05-21	2018-05-20
Signal generator	R&S	SMB 100A	102594	2018-05-20	2019-05-19
Signal generator	R&S	SMB 100A	102594	2019-05-19	2020-05-18
Climatic Chamber	ESPEC	SU-242	93000506	2017-12-17	2020-12-16
Preamplifier	R&S	SCU18	102327	2017-05-21	2018-05-20
Preamplifier	R&S	SCU18	102327	2018-05-20	2019-05-19
Preamplifier	R&S	SCU18	102327	2019-05-19	2020-05-18



MOB COMMS DC SUPPLY	Keysight	66319D	MY43004105	2017-05-21	2018-05-20
MOB COMMS DC SUPPLY	Keysight	66319D	MY43004105	2018-05-20	2019-05-19
MOB COMMS DC SUPPLY	Keysight	66319D	MY43004105	2019-05-19	2020-05-18
RF Cable	Agilent	SMA 15cm	0001	2017-12-17	2018-06-16
RF Cable	Agilent	SMA 15cm	0001	2018-06-16	2018-12-15
RF Cable	Agilent	SMA 15cm	0001	2018-12-15	2019-06-14
RF Cable	Agilent	SMA 15cm	0001	2019-06-14	2019-12-13
RF Cable	Agilent	SMA 15cm	0001	2019-12-13	2020-06-12
Software	R&S	EMC32	9.26.0	/	/

\*\*\*\*\*END OF REPORT \*\*\*\*\*



## ANNEX A: The EUT Appearance

The EUT Appearance are submitted separately.



## ANNEX B: Test Setup Photos

The Test Setup Photos are submitted separately.





## **ANNEX C: Product Change Description**

The Product Change Description are submitted separately.



## **ANNEX D: Verify data**

The Verify data are submitted separately.