

EC25 Mini PCIe

Hardware Design

LTE Standard Module Series

Rev. EC25_Mini_PCl_e_Hardware_Design_V2.2

Date: 2019-08-19

Status: Released



Our aim is to provide customers with timely and comprehensive service. For any assistance, please contact our company headquarters:

Quectel Wireless Solutions Co., Ltd.

Building 5, Shanghai Business Park Phase III (Area B), No.1016 Tianlin Road, Minhang District, Shanghai, China 200233

Tel: +86 21 5108 6236

Email: info@quectel.com

Or our local office. For more information, please visit:

<http://www.quectel.com/support/sales.htm>

For technical support, or to report documentation errors, please visit:

<http://www.quectel.com/support/technical.htm>

Or email to: support@quectel.com

GENERAL NOTES

QUECTEL OFFERS THE INFORMATION AS A SERVICE TO ITS CUSTOMERS. THE INFORMATION PROVIDED IS BASED UPON CUSTOMERS' REQUIREMENTS. QUECTEL MAKES EVERY EFFORT TO ENSURE THE QUALITY OF THE INFORMATION IT MAKES AVAILABLE. QUECTEL DOES NOT MAKE ANY WARRANTY AS TO THE INFORMATION CONTAINED HEREIN, AND DOES NOT ACCEPT ANY LIABILITY FOR ANY INJURY, LOSS OR DAMAGE OF ANY KIND INCURRED BY USE OF OR RELIANCE UPON THE INFORMATION. ALL INFORMATION SUPPLIED HEREIN IS SUBJECT TO CHANGE WITHOUT PRIOR NOTICE.

COPYRIGHT

THE INFORMATION CONTAINED HERE IS PROPRIETARY TECHNICAL INFORMATION OF QUECTEL WIRELESS SOLUTIONS CO., LTD. TRANSMITTING, REPRODUCTION, DISSEMINATION AND EDITING OF THIS DOCUMENT AS WELL AS UTILIZATION OF THE CONTENT ARE FORBIDDEN WITHOUT PERMISSION. OFFENDERS WILL BE HELD LIABLE FOR PAYMENT OF DAMAGES. ALL RIGHTS ARE RESERVED IN THE EVENT OF A PATENT GRANT OR REGISTRATION OF A UTILITY MODEL OR DESIGN.

Copyright © Quectel Wireless Solutions Co., Ltd. 2019. All rights reserved.

About the Document

History

Revision	Date	Author	Description
1.0	2016-06-07	Mountain ZHOU/ Frank WANG	Initial
1.1	2017-01-24	Lyndon LIU/ Frank WANG	<ol style="list-style-type: none"> Deleted description of EC25-AUT Mini PCIe in Table 1. Added description of EC25-AU and EC25-J Mini PCIe in Table 1. Updated key features of EC25 Mini PCIe in Table 2. Added current consumption in Chapter 4.7. Updated conducted RF receiving sensitivity of EC25-A Mini PCIe in Table 17. Added conducted RF receiving sensitivity of EC25-J Mini PCIe in Table 18.
2.0	2019-04-30	Nathan LIU/ Frank WANG/ Ward WANG/ Ethan SHAN	<ol style="list-style-type: none"> Added new variants EC25-AF Mini PCIe, EC25-EU Mini PCIe, EC25-EC Mini PCIe, EC25-EUX Mini PCIe, EC25-MX Mini PCIe and their related information. Updated LTE ,UMTS and GSM features, and added storage temperature range in Table 2. Added pin definition and description of pin 3, 5, 44 in Figure 2 and Table 4. Modified the reference circuit of USB interface in Figure 6. Updated the mechanical dimension of EC25 Mini PCIe in Figure 18. Added USIM_PRESENCE in (U)SIM interface and updated the reference circuit in Chapter 3.4.

7. Added COEX UART interface (under development) as UART interface in Chapter 3.6.
8. Modified description of W_DISABLE# signal in Chapter 3.8.3.
9. Modified description of LED_WWAN# signal in Chapter 3.8.5.
10. Updated description of antenna connection in Chapter 5.
11. Added thermal consideration in Chapter 6.7.
12. Added operating frequencies in Table 16.
13. Added GNSS frequency in Table 17.
14. Updated antenna requirements in Table 18.
15. Updated EC25 Mini PCIe conducted RF output power in Table 21.
16. Updated conducted RF receiving sensitivity of EC25-A Mini PCIe in Table 22.
17. Added conducted RF receiving sensitivity of EC25-AU Mini PCIe in Table 23.
18. Updated conducted RF receiving sensitivity of EC25-J Mini PCIe in Table 24.
19. Updated conducted RF receiving sensitivity of EC25-E Mini PCIe in Table 25.
20. Updated conducted RF receiving sensitivity of EC25-V Mini PCIe in Table 26.
21. Added conducted RF receiving sensitivity of EC25-AF Mini PCIe in Table 27.
22. Added conducted RF receiving sensitivity of EC25-EU Mini PCIe in Table 28.
23. Added conducted RF receiving sensitivity of EC25-EC Mini PCIe in Table 29.
24. Added conducted RF receiving sensitivity of EC25-EUX Mini PCIe in Table 30.
25. Added current consumption of EC25-AU Mini PCIe in Table 33.
26. Added current consumption of EC25-J Mini PCIe in Table 34.
27. Added current consumption of EC25-AF Mini PCIe in Table 37.
28. Added current consumption of EC25-EC Mini PCIe in Table 38.
29. Added current consumption of EC25-EUX Mini PCIe in Table 39.

2.1	2019-07-05	Fanny CHEN/ Ethan SHAN	<ol style="list-style-type: none"> 1. Added EC25-AFX/-AUX Mini PCIe and related information. 2. Updated supported protocols and USB serial drivers in Table 2. 3. Added EC25-AFX Mini PCIe conducted RF receiving sensitivity in Table 28. 4. Updated conducted RF receiving sensitivity of EC25-EU Mini PCIe in Table 29. 5. Updated EC25-AF Mini PCIe current consumption in Table 39. 6. Added EC25-AFX Mini PCIe current consumption in Table 42. 7. Added EC25-MX Mini PCIe conducted RF receiving sensitivity in Table 32. 8. Added EC25-MX Mini PCIe current consumption in Table 43.
2.2	2019-08-19	Ward WANG/ Owen WEI	<ol style="list-style-type: none"> 1. Deleted the information of GNSS supported on EC25-EC Mini PCIe in Table 1. 2. Updated conducted RF receiving sensitivity of EC25-AU Mini PCIe in Table 24. 3. Updated conducted RF receiving sensitivity of EC25-EU Mini PCIe in Table 30. 4. Added conducted RF receiving sensitivity of EC25-AUX Mini PCIe in Table 34. 5. Updated current consumption of EC25-J Mini PCIe in Table 38. 6. Added current consumption of EC25-AUX Mini PCIe in Table 45. 7. Added current consumption of EC25-EU Mini PCIe in Table 46. 8. Deleted current consumption of EC21-EC Mini PCIe, and the data will be updated in the future version.

Contents

About the Document	2
Contents.....	5
Table Index	7
Figure Index.....	9
1 Introduction	10
1.1. Safety Information.....	11
2 Product Concept	13
2.1. General Description	13
2.2. Description of Product Series.....	14
2.3. Key Features.....	16
2.4. Functional Diagram.....	18
3 Application Interfaces.....	19
3.1. Pin Assignment	19
3.2. Pin Description.....	20
3.3. Power Supply.....	23
3.4. (U)SIM Interface.....	24
3.5. USB Interface.....	26
3.6. UART Interfaces.....	28
3.7. PCM and I2C Interfaces.....	29
3.8. Control and Indicator Signals	31
3.8.1. RI Signal	32
3.8.2. DTR Signal	32
3.8.3. W_DISABLE# Signal	32
3.8.4. PERST# Signal.....	33
3.8.5. LED_WWAN# Signal	33
3.8.6. WAKE# Signal	34
4 GNSS Receiver	35
5 Antenna Connection	36
5.1. Operating Frequency	36
5.2. GNSS Frequency	37
5.3. GNSS Performance	38
5.4. Antenna Requirements.....	39
5.4.1. Antenna Requirements	39
5.4.2. Antenna Connectors and Mating Plugs	40
6 Electrical, Reliability and Radio Characteristics	42
6.1. General Description	42
6.2. Power Supply Requirements.....	42

6.3.	I/O Requirements	43
6.4.	RF Characteristics	43
6.5.	ESD Characteristics	51
6.6.	Current Consumption	51
6.7.	Thermal Consideration.....	70
7	Dimensions and Packaging.....	72
7.1.	General Description	72
7.2.	Mechanical Dimensions of EC25 Mini PCIe.....	72
7.3.	Standard Dimensions of Mini PCI Express.....	73
7.4.	Packaging Specifications	74
8	Appendix A References.....	75

Table Index

TABLE 1: DESCRIPTION OF EC25 MINI PCIE.....	14
TABLE 2: KEY FEATURES OF EC25 MINI PCIE	16
TABLE 3: I/O PARAMETERS DEFINITION.....	20
TABLE 4: PIN DESCRIPTION.....	20
TABLE 5: DEFINITION OF VCC_3V3 AND GND PINS	23
TABLE 6: PIN DEFINITION OF (U)SIM INTERFACE	24
TABLE 7: PIN DEFINITION OF USB INTERFACE	26
TABLE 8: PIN DEFINITION OF MAIN UART INTERFACE.....	28
TABLE 9: PIN DEFINITION OF COEX UART INTERFACE.....	28
TABLE 10: PIN DEFINITION OF PCM AND I2C INTERFACES	29
TABLE 11: PIN DEFINITION OF CONTROL AND INDICATOR SIGNALS.....	31
TABLE 12: AIRPLANE MODE CONTROLLED BY HARDWARE METHOD.....	32
TABLE 13: AIRPLANE MODE CONTROLLED BY SOFTWARE METHOD	33
TABLE 14: INDICATIONS OF NETWORK STATUS (AT+QCFG="LEDMODE",0, DEFAULT SETTING).....	34
TABLE 15: INDICATIONS OF NETWORK STATUS (AT+QCFG="LEDMODE",2)	34
TABLE 16: OPERATING FREQUENCIES	36
TABLE 17: GNSS FREQUENCY.....	38
TABLE 18: GNSS PERFORMANCE	38
TABLE 19: ANTENNA REQUIREMENTS.....	39
TABLE 20: POWER SUPPLY REQUIREMENTS.....	42
TABLE 21: I/O REQUIREMENTS.....	43
TABLE 22: CONDUCTED RF OUTPUT POWER OF EC25 MINI PCIE.....	43
TABLE 23: CONDUCTED RF RECEIVING SENSITIVITY OF EC25-A MINI PCIE	44
TABLE 24: CONDUCTED RF RECEIVING SENSITIVITY OF EC25-AU MINI PCIE	44
TABLE 25: CONDUCTED RF RECEIVING SENSITIVITY OF EC25-J MINI PCIE	45
TABLE 26: CONDUCTED RF RECEIVING SENSITIVITY OF EC25-E MINI PCIE.....	45
TABLE 27: CONDUCTED RF RECEIVING SENSITIVITY OF EC25-V MINI PCIE.....	46
TABLE 28: CONDUCTED RF RECEIVING SENSITIVITY OF EC25-AF MINI PCIE.....	46
TABLE 29: CONDUCTED RF RECEIVING SENSITIVITY OF EC25-AFX MINI PCIE	47
TABLE 30: CONDUCTED RF RECEIVING SENSITIVITY OF EC25-EU MINI PCIE	47
TABLE 31: CONDUCTED RF RECEIVING SENSITIVITY OF EC25-EC MINI PCIE	48
TABLE 32: CONDUCTED RF RECEIVING SENSITIVITY OF EC25-EUX MINI PCIE.....	49
TABLE 33: CONDUCTED RF RECEIVING SENSITIVITY OF EC25-MX MINI PCIE.....	49
TABLE 34: CONDUCTED RF RECEIVING SENSITIVITY OF EC25-AUX MINI PCIE.....	50
TABLE 35: ESD CHARACTERISTICS OF EC25 MINI PCIE.....	51
TABLE 36: CURRENT CONSUMPTION OF EC25-A MINI PCIE	51
TABLE 37: CURRENT CONSUMPTION OF EC25-AU MINI PCIE	52
TABLE 38: CURRENT CONSUMPTION OF EC25-J MINI PCIE.....	54
TABLE 39: CURRENT CONSUMPTION OF EC25-E MINI PCIE	56
TABLE 40: CURRENT CONSUMPTION OF EC25-V MINI PCIE	58
TABLE 41: CURRENT CONSUMPTION OF EC25-AF MINI PCIE.....	58

TABLE 42: CURRENT CONSUMPTION OF EC25-EUX MINI PCIE	60
TABLE 43: CURRENT CONSUMPTION OF EC25-AFX MINI PCIE	62
TABLE 44: CURRENT CONSUMPTION OF EC25-MX MINI PCIE	63
TABLE 45: CURRENT CONSUMPTION OF EC25-AUX MINI PCIE	65
TABLE 46: CURRENT CONSUMPTION OF EC25-EU MINI PCIE	68
TABLE 47: GNSS CURRENT CONSUMPTION OF EC25 MINI PCIE SERIES MODULE.....	70
TABLE 48: RELATED DOCUMENTS	75
TABLE 49: TERMS AND ABBREVIATIONS	75

Figure Index

FIGURE 1: FUNCTIONAL DIAGRAM	18
FIGURE 2: PIN ASSIGNMENT	19
FIGURE 3: REFERENCE CIRCUIT OF POWER SUPPLY	24
FIGURE 4: REFERENCE CIRCUIT OF (U)SIM INTERFACE WITH AN 8-PIN (U)SIM CARD CONNECTOR	25
FIGURE 5: REFERENCE CIRCUIT OF (U)SIM INTERFACE WITH A 6-PIN (U)SIM CARD CONNECTOR...	25
FIGURE 6: REFERENCE CIRCUIT OF USB INTERFACE	27
FIGURE 7: TIMING IN PRIMARY MODE.....	30
FIGURE 8: TIMING IN AUXILIARY MODE	30
FIGURE 9: REFERENCE CIRCUIT OF PCM APPLICATION WITH AUDIO CODEC	31
FIGURE 10: RI BEHAVIORS.....	32
FIGURE 11: TIMING OF RESETTING MODULE.....	33
FIGURE 12: LED_WWAN# SIGNAL REFERENCE CIRCUIT DIAGRAM	33
FIGURE 13: WAKE# BEHAVIOR	34
FIGURE 14: DIMENSIONS OF THE ANTENNA CONNECTORS (UNIT: MM).....	40
FIGURE 15: MECHANICALS OF U.FL-LP MATING PLUGS	40
FIGURE 16: SPACE FACTOR OF MATING PLUGS (UNIT: MM).....	41
FIGURE 17: REFERENCED HEATSINK DESIGN	71
FIGURE 18: MECHANICAL DIMENSIONS OF EC25 MINI PCIE	72
FIGURE 19: STANDARD DIMENSIONS OF MINI PCI EXPRESS.....	73
FIGURE 20: DIMENSIONS OF THE MINI PCI EXPRESS CONNECTOR (MOLEX 679100002).....	74

1 Introduction

This document defines EC25 Mini PCIe module, and describes its air interfaces and hardware interfaces which are connected with customers' applications.

This document can help customers quickly understand module interface specifications, electrical and mechanical details as well as other related information of EC25 Mini PCIe module. To facilitate its application in different fields, relevant reference design is also provided for customers' reference. Associated with application note and user guide, customers can use the module to design and set up mobile applications easily.

1. CAUTION : RISK OF EXPLOSION IF BATTERY IS REPLACED BY AN INCORRECT TYPE. DISPOSE OF USED BATTERIES ACCORDING TO THE INSTRUCTIONS.
2. Operating temperature: -40 °C to 85° C
3. EC25-AUX, EC25-AUX MINIPCIEmax support frequency bands : GSM900/1800 , WCDMA I/V/VIII, LTE Band 1/3/5/7/8/20/28/40 ;
4. EC25-AUX, EC25-AUX MINIPCIEmax output power :
GSM900/1800 , WCDMA I/V/VIII, LTE Band 1/3/5/7/8/20/28/40 : 23dBm ;

The antenna(s) used for this transmitter must not be co-located or operating in conjunction with any other antenna or transmitter and must be installed to provide a separation distance of at least 20cm from all persons.

Declaration of Conformity

Hereby, Quectel Wireless Solutions Co., Ltd

declares that the radio equipment type EC25-AUX, EC25-AUX
MINIPCIEmax is in compliance with

Directives: 2014/53/EU. The full text of the EU declaration of conformity is available
at the following internet

address: <http://www.quectel.com/support/downloadb/TechnicalDocuments.htm>

1.1. Safety Information

The following safety precautions must be observed during all phases of operation, such as usage, service or repair of any cellular terminal or mobile incorporating EC25 Mini PCIe module. Manufacturers of the cellular terminal should send the following safety information to users and operating personnel, and incorporate these guidelines into all manuals supplied with the product. If not so, Quectel assumes no liability for customers' failure to comply with these precautions.



Full attention must be given to driving at all times in order to reduce the risk of an accident. Using a mobile while driving (even with a handsfree kit) causes distraction and can lead to an accident. Please comply with laws and regulations restricting the use of wireless devices while driving.



Switch off the cellular terminal or mobile before boarding an aircraft. The operation of wireless appliances in an aircraft is forbidden to prevent interference with communication systems. If the device offers an Airplane Mode, then it should be enabled prior to boarding an aircraft. Please consult the airline staff for more restrictions on the use of wireless devices on boarding the aircraft.



Wireless devices may cause interference on sensitive medical equipment, so please be aware of the restrictions on the use of wireless devices when in hospitals, clinics or other healthcare facilities.



Cellular terminals or mobiles operating over radio signals and cellular network cannot be guaranteed to connect in all possible conditions (for example, with unpaid bills or with an invalid (U)SIM card). When emergent help is needed in such conditions, please remember using emergency call. In order to make or receive a call, the cellular terminal or mobile must be switched on in a service area with adequate cellular signal strength.



The cellular terminal or mobile contains a transmitter and receiver. When it is ON, it receives and transmits radio frequency signals. RF interference can occur if it is used close to TV set, radio, computer or other electric equipment.



In locations with potentially explosive atmospheres, obey all posted signs to turn off wireless devices such as your phone or other cellular terminals. Areas with potentially explosive atmospheres include fuelling areas, below decks on boats, fuel or chemical transfer or storage facilities, areas where the air contains chemicals or particles such as grain, dust or metal powders, etc.

2 Product Concept

2.1. General Description

EC25 Mini PCIe module provides data connectivity on LTE-FDD, LTE-TDD, DC-HSDPA, HSPA+, HSDPA, HSUPA, WCDMA, EDGE and GPRS networks with PCI Express Mini Card 1.2 standard interface. It supports embedded operating systems such as Linux, Android, etc., and also provides audio, high-speed data transmission and GNSS functionalities for customers' applications.

EC25 Mini PCIe module can be applied in the following fields:

- PDA and Laptop Computer
- Remote Monitor System
- Vehicle System
- Wireless POS System
- Intelligent Meter Reading System
- Wireless Router and Switch
- Other Wireless Terminal Devices

This chapter generally introduces the following aspects of EC25 Mini PCIe module:

- Product Series
- Key Features
- Functional Diagram

NOTE

EC25 Mini PCIe contains **Telematics** version and **Data-only** version. **Telematics** version supports voice and data functions, while **Data-only** version only supports data function.

2.2. Description of Product Series

EC25 Mini PCIe series contains 12 variants, and are listed in the following table.

Table 1: Description of EC25 Mini PCIe

Product Series	Description
EC25-A Mini PCIe	Support LTE-FDD: B2/B4/B12 Support WCDMA: B2/B4/B5 Support LTE/WCDMA receive diversity Support GNSS ¹⁾ Support digital audio ²⁾
EC25-AU Mini PCIe ³⁾	Support LTE-FDD: B1/B2/B3/B4/B5/B7/B8/B28 Support LTE-TDD: B40 Support WCDMA: B1/B2/B5/B8 Support GSM: 850/900/1800/1900MHz Support LTE/WCDMA receive diversity ³⁾ Support GNSS ¹⁾ Support digital audio ²⁾
EC25-J Mini PCIe	Support LTE-FDD: B1/B3/B8/B18/B19/B26 Support LTE-TDD: B41 Support WCDMA: B1/B6/B8/B19 Support LTE/WCDMA receive diversity Support GNSS ¹⁾ Support digital audio ²⁾
EC25-E Mini PCIe	Support LTE-FDD: B1/B3/B5/B7/B8/B20 Support LTE-TDD: B38/B40/B41 Support WCDMA: B1/B5/B8 Support GSM: 900/1800MHz Support LTE/WCDMA receive diversity Support GNSS ¹⁾ Support digital audio ²⁾
EC25-V Mini PCIe	Support LTE-FDD: B4/B13 Support LTE receive diversity Support GNSS ¹⁾ Support digital audio ²⁾
EC25-AF Mini PCIe	Support LTE-FDD: B2/B4/B5/B12/B13/B14/B66/B71 Support WCDMA: B2/B4/B5 Support LTE/WCDMA receive diversity Support GNSS ¹⁾ Support digital audio ²⁾

EC25-EU Mini PCIe	<p>Support LTE-FDD: B1/B3/B7/B8/B20/B28A Support LTE-TDD: B38/B40/B41 Support WCDMA: B1/B8 Support GSM: 900/1800MHz Support LTE/WCDMA receive diversity Support GNSS¹⁾ Support digital audio²⁾</p>
EC25-EC Mini PCIe	<p>Support LTE-FDD: B1/B3/B7/B8/B20/B28A Support WCDMA: B1/B8 Support GSM: 900/1800MHz Support LTE/WCDMA receive diversity Support digital audio²⁾</p>
EC25-EUX Mini PCIe ⁴⁾	<p>Support LTE-FDD: B1/B3/B7/B8/B20/B28A Support LTE-TDD: B38/B40/B41 Support WCDMA: B1/B8 Support GSM: 900/1800MHz Support LTE/WCDMA receive diversity Support GNSS¹⁾ Support digital audio²⁾</p>
EC25-MX Mini PCIe ⁴⁾	<p>Support LTE-FDD: B2/B4/B5/B7/B28/B66 Support WCDMA: B2/B4/B5 Support LTE/WCDMA receive diversity Support digital audio²⁾</p>
EC25-AFX Mini PCIe ⁴⁾	<p>Support LTE-FDD: B2/B4/B5/B12/B13/B14/B66/B71 Support WCDMA: B2/B4/B5 Support LTE/WCDMA receive diversity Support GNSS¹⁾ Support digital audio²⁾</p>
EC25-AUX Mini PCIe ³⁾⁴⁾	<p>Support LTE-FDD: B1/B2/B3/B4/B5/B7/B8/B28³⁾ Support LTE-TDD: B40 Support WCDMA: B1/B2/B4/B5/B8 Support GSM: 850/900/1800/1900MHz Support LTE/WCDMA receive diversity³⁾ Support GNSS¹⁾ Support digital audio²⁾</p>

NOTES

- ¹⁾ GNSS function is optional.
- ²⁾ Digital audio (PCM) function is only supported on **Telematics** version.
- ³⁾ B2 band on EC25-AU/-AUX Mini PCIe does not support receive diversity.
- ⁴⁾ EC25-EUX/-MX/-AFX/-AUX Mini PCIe are based on ThreadX OS.

2.3. Key Features

The following table describes the detailed features of EC25 Mini PCIe module.

Table 2: Key Features of EC25 Mini PCIe

Feature	Details
Function Interface	PCI Express Mini Card 1.2 Standard Interface
Power Supply	Supply voltage: 3.0V~3.6V Typical supply voltage: 3.3V
Transmitting Power	Class 4 (33dBm±2dB) for GSM850 Class 4 (33dBm±2dB) for EGSM900 Class 1 (30dBm±2dB) for DCS1800 Class 1 (30dBm±2dB) for PCS1900 Class E2 (27dBm±3dB) for GSM850 8-PSK Class E2 (27dBm±3dB) for EGSM900 8-PSK Class E2 (26dBm±3dB) for DCS1800 8-PSK Class E2 (26dBm±3dB) for PCS1900 8-PSK Class 3 (24dBm+1/-3dB) for WCDMA bands Class 3 (23dBm±2dB) for LTE-FDD bands Class 3 (23dBm±2dB) for LTE-TDD bands
LTE Features	Support up to non-CA Cat 4 FDD and TDD Support 1.4/3/5/10/15/20MHz RF bandwidth Support MIMO in DL direction LTE-FDD: Max 150Mbps (DL)/Max 50Mbps (UL) LTE-TDD: Max 130Mbps (DL)/Max 30Mbps (UL)
UMTS Features	Support 3GPP R8 DC-HSDPA, HSPA+, HSDPA, HSUPA and WCDMA Support QPSK, 16-QAM and 64-QAM modulation DC-HSDPA: Max 42Mbps (DL) HSUPA: Max 5.76Mbps (UL) WCDMA: Max 384Kbps (DL)/Max 384Kbps (UL)
GSM Features	GPRS: Support GPRS multi-slot class 33 (33 by default) Coding scheme: CS-1, CS-2, CS-3 and CS-4 Max 107Kbps (DL)/Max 85.6Kbps (UL) EDGE: Support EDGE multi-slot class 33 (33 by default) Support GMSK and 8-PSK for different MCS (Modulation and Coding Scheme) Downlink coding schemes: CS 1-4 and MCS 1-9 Uplink coding schemes: CS 1-4 and MCS 1-9

	Max 296Kbps (DL)/Max 236.8Kbps (UL)
Internet Protocol Features	Support TCP/UDP/PPP/FTP/FTPS/HTTP/HTTPS/NTP/PING/QMI/NITZ/MMS/SMTP/SSL/MQTT/FILE/CMUX*/SMTPS* protocols Support protocols PAP (Password Authentication Protocol) and CHAP (Challenge Handshake Authentication Protocol) which are usually used for PPP connection
SMS	Text and PDU mode Point to point MO and MT SMS cell broadcast SMS storage: ME by default
(U)SIM Interface	Support USIM/SIM card: 1.8V, 3.0V
UART Interfaces	Main UART: Support RTS and CTS hardware flow control Baud rate can reach up to 230400bps, 115200bps by default Used for AT command communication and data transmission COEX UART*: LTE/WLAN&BT coexistence UART
Audio Features	Support one digital audio interface: PCM interface GSM: HR/FR/EFR/AMR/AMR-WB WCDMA: AMR/AMR-WB LTE: AMR/AMR-WB Support echo cancellation and noise suppression
PCM Interface	Support 16-bit linear data format Support long frame synchronization and short frame synchronization Support master and slave modes, but must be the master in long frame synchronization
USB Interface	Compliant with USB 2.0 specification (slave only); the data transfer rate can reach up to 480Mbps Used for AT command communication, data transmission, GNSS NMEA output, software debugging, firmware upgrade and voice over USB Support USB serial drivers for: Windows 7/8/8.1/10, Linux 2.6/3.x/4.1~4.15, Android 4.x/5.x/6.x/7.x/8.x/9.x, etc.
Antenna Connectors	Include main antenna, diversity antenna and GNSS antenna receptacle connectors
Rx-diversity	Support LTE/WCDMA Rx-diversity
GNSS Features	Gen8C Lite of Qualcomm Protocol: NMEA 0183
AT Commands	Compliant with 3GPP TS 27.007, 27.005 and Quectel enhanced AT commands
Physical Characteristics	Size: (51.0±0.15)mm × (30.0±0.15)mm × (4.9±0.2)mm Weight: approx. 9.8g

Temperature Range	Operation temperature range: -35°C ~ +75°C ¹⁾ Extended temperature range: -40°C ~ +80°C ²⁾ Storage temperature range: -40°C ~ +90°C
Firmware Upgrade	Upgrade via USB interface or DFOTA*
RoHS	All hardware components are fully compliant with EU RoHS directive

NOTES

- COEX UART interface is not supported on ThreadX modules.
- ¹⁾ Within operation temperature range, the module is 3GPP compliant.
- ²⁾ Within extended temperature range, the module remains the ability to establish and maintain a voice, SMS, data transmission, emergency call* (emergency call is not supported on ThreadX modules), etc. There is no unrecoverable malfunction. There are also no effects on radio spectrum and no harm to radio network. Only one or more parameters like P_{out} might reduce in their value and exceed the specified tolerances. When the temperature returns to normal operation temperature levels, the module will meet 3GPP specifications again.
- “*” means under development.

2.4. Functional Diagram

The following figure shows the block diagram of EC25 Mini PCIe.

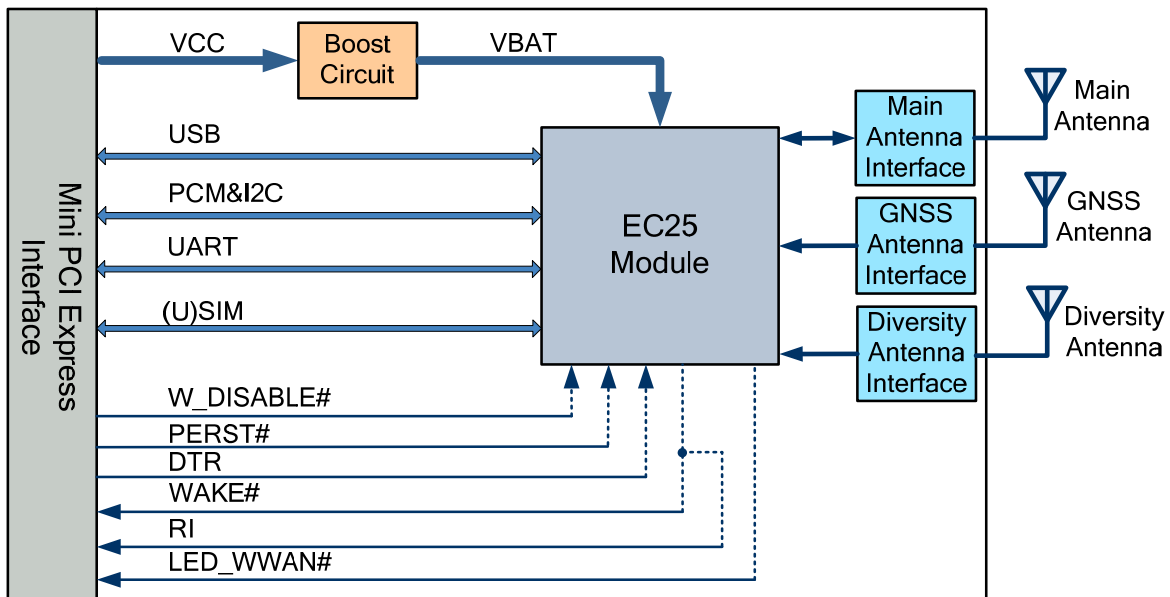

Figure 1: Functional Diagram

3 Application Interfaces

The physical connections and signal levels of EC25 Mini PCIe comply with PCI Express Mini Card Electromechanical Specification. This chapter mainly describes the definition and application of the following interfaces of EC25 Mini PCIe:

- Power supply
- (U)SIM interface
- USB interface
- UART interfaces
- PCM and I2C interfaces
- Control and indicator signals
- Antenna interfaces

3.1. Pin Assignment

The following figure shows the pin assignment of EC25 Mini PCIe module. The top side contains EC25 module and antenna connectors.

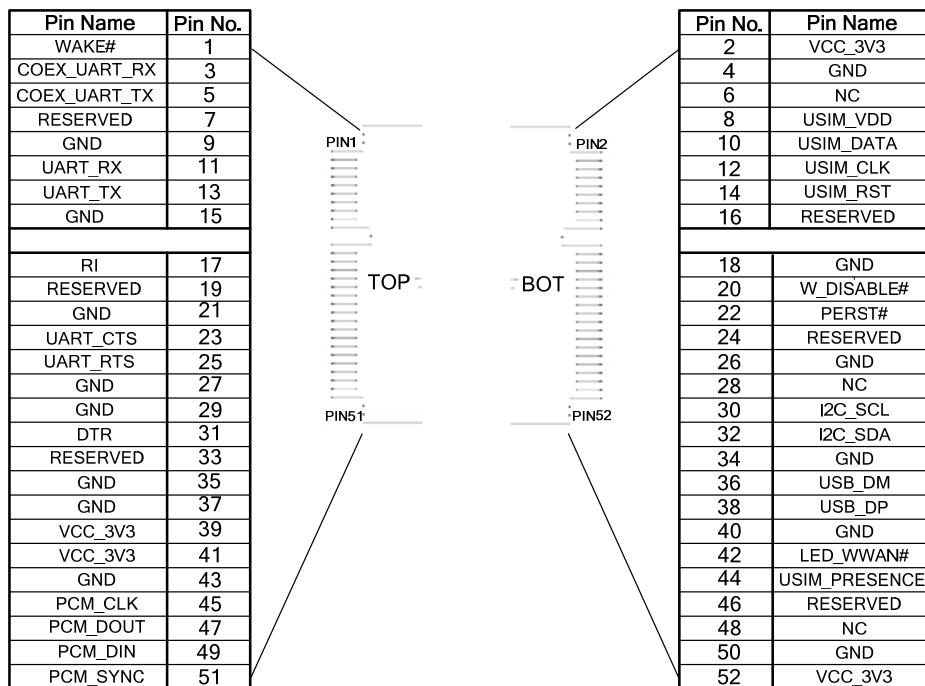

Figure 2: Pin Assignment

3.2. Pin Description

The following tables show the pin definition and description of the 52 pins on EC25 Mini PCIe .

Table 3: I/O Parameters Definition

Type	Description
DI	Digital Input
DO	Digital Output
IO	Bidirectional
OC	Open Collector
PI	Power Input
PO	Power Output

Table 4: Pin Description

Pin No.	Mini PCI Express Standard Name	EC25 Mini PCIe Pin Name	I/O	Description	Comment
1	WAKE#	WAKE#	OC	Output signal used to wake up the host.	
2	3.3Vaux	VCC_3V3	PI	3.3V DC supply	
3	COEX1	COEX_UART_RX ¹⁾	DI	LTE/WLAN&BT coexistence signal	It is prohibited to be pulled up to high level before startup.
4	GND	GND		Mini card ground	
5	COEX2	COEX_UART_TX ¹⁾	DO	LTE/WLAN&BT coexistence signal	It is prohibited to be pulled up to high level before startup.
6	1.5V	NC		Not connected	
7	CLKREQ#	RESERVED		Reserved	
8	UIM_PWR	USIM_VDD	PO	Power source for the (U)SIM card	

9	GND	GND		Mini card ground	
10	UIM_DATA	USIM_DATA	IO	Data signal of (U)SIM card	
11	REFCLK-	UART_RX	DI	UART receive data	Connect to DTE's TX.
12	UIM_CLK	USIM_CLK	DO	Clock signal of (U)SIM card	
13	REFCLK+	UART_TX	DO	UART transmit data	Connect to DTE's RX.
14	UIM_RESET	USIM_RST	DO	Reset signal of (U)SIM card	
15	GND	GND		Mini card ground	
16	UIM_VPP	RESERVED		Reserved	
17	RESERVED	RI	DO	Output signal to wake up the host.	
18	GND	GND		Mini card ground	
19	RESERVED	RESERVED		Reserved	
20	W_DISABLE#	W_DISABLE#	DI	Airplane mode control	Pulled up by default. Active low.
21	GND	GND		Mini card ground	
22	PERST#	PERST#	DI	Fundamental reset signal	Pulled up by default. Active low.
23	PERn0	UART_CTS	DI	UART clear to send	Connect to DTE's RTS.
24	3.3Vaux	RESERVED		Reserved	
25	PERp0	UART_RTS	DO	UART request to send	Connect to DTE's CTS.
26	GND	GND		Mini card ground	
27	GND	GND		Mini card ground	
28	1.5V	NC		Not connected	
29	GND	GND		Mini card ground	
30	SMB_CLK	I2C_SCL	DO	I2C serial clock	Require external pull-up

					to 1.8V.
31	PETn0	DTR	DI	Sleep mode control	
32	SMB_DATA	I2C_SDA	IO	I2C serial data	Require external pull-up to 1.8V.
33	PETp0	RESERVED		Reserved	
34	GND	GND		Mini card ground	
35	GND	GND		Mini card ground	
36	USB_D-	USB_DM	IO	USB differential data (-)	Require differential impedance of 90Ω.
37	GND	GND		Mini card ground	
38	USB_D+	USB_DP	IO	USB differential data (+)	Require differential impedance of 90Ω.
39	3.3Vaux	VCC_3V3	PI	3.3V DC supply	
40	GND	GND		Mini card ground	
41	3.3Vaux	VCC_3V3	PI	3.3V DC supply	
42	LED_WWAN#	LED_WWAN#	OC	LED signal for indicating the network status of the module	Active low
43	GND	GND		Mini card ground	
44	LED_WLAN#	USIM_PRESENCE	DI	(U)SIM card insertion detection	
45	RESERVED	PCM_CLK ²⁾	IO	PCM clock signal	
46	LED_WPAN#	RESERVED		Reserved	
47	RESERVED	PCM_DOUT ²⁾	DO	PCM data output	
48	1.5V	NC		Not connected	
49	RESERVED	PCM_DIN ²⁾	DI	PCM data input	
50	GND	GND		Mini card ground	

51	RESERVED	PCM_SYNC ²⁾	IO	PCM frame synchronization
52	3.3Vaux	VCC_3V3	PI	3.3V DC supply

NOTES

- ¹⁾ COEX UART interface pins (pins 3 and 5) are not supported on ThreadX modules, and the function is under development.
- ²⁾ The digital audio (PCM) function is only supported on **Telematics** version.
- Keep all NC, reserved and unused pins unconnected.

3.3. Power Supply

The following table shows pin definition of VCC_3V3 pins and ground pins.

Table 5: Definition of VCC_3V3 and GND Pins

Pin Name	Pin No.	I/O	Power Domain	Description
VCC_3V3	2, 39, 41, 52	PI	3.0V~3.6V	3.3V DC supply
GND	4, 9, 15, 18, 21, 26, 27, 29, 34, 35, 37, 40, 43, 50			Mini card ground

The typical supply voltage of EC25 Mini PCIe is 3.3V. In the 2G network, the input peak current may reach 2.7A during the transmitting time. Therefore, the power supply must be able to provide enough current, and a bypass capacitor of no less than 470 μ F with low ESR should be used to prevent the voltage from dropping.

The following figure shows a reference design of power supply. The precision of resistor R2 and R3 is 1%, and the capacitor C3 needs a low ESR.

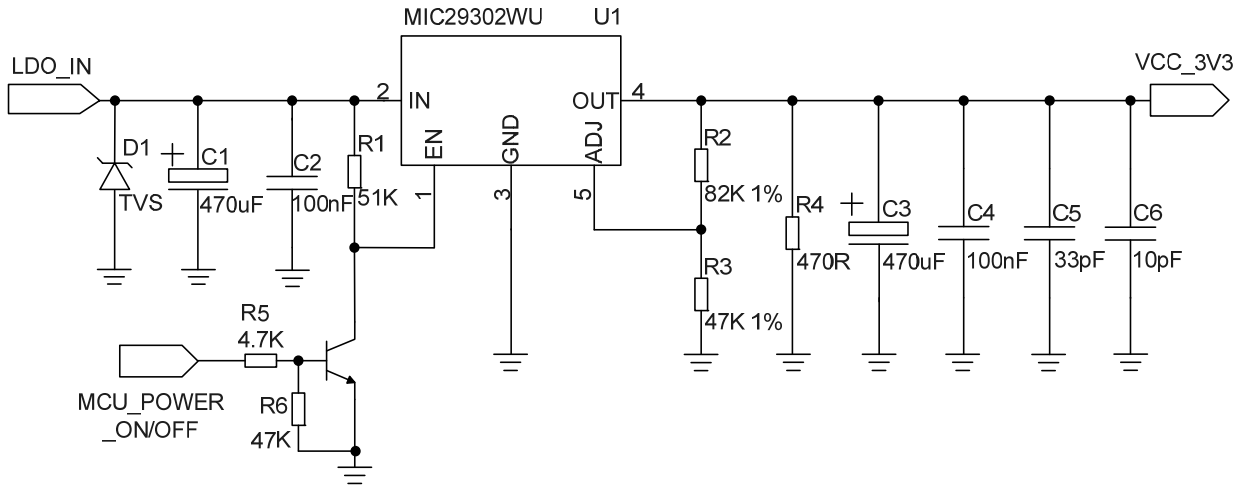

Figure 3: Reference Circuit of Power Supply

3.4. (U)SIM Interface

The (U)SIM interface circuitry meets ETSI and IMT-2000 requirements. Both 1.8V and 3.0V (U)SIM cards are supported. The following table shows the pin definition of (U)SIM interface.

Table 6: Pin Definition of (U)SIM Interface

Pin Name	Pin No.	I/O	Power Domain	Description
USIM_VDD	8	PO	1.8V/3.0V	Power source for (U)SIM card
USIM_DATA	10	IO	1.8V/3.0V	Data signal of (U)SIM card
USIM_CLK	12	DO	1.8V/3.0V	Clock signal of (U)SIM card
USIM_RST	14	DO	1.8V/3.0V	Reset signal of (U)SIM card
USIM_PRESENCE	44	DI	1.8V	(U)SIM card insertion detection

EC25 Mini PCIe supports (U)SIM card hot-plug via the USIM_PRESENCE pin. The function supports low level and high level detections, and it is disabled by default. For more details of **AT+QSIMDET** command, please refer to **document [2]**.

The following figure shows a reference design for (U)SIM interface with an 8-pin (U)SIM card connector.

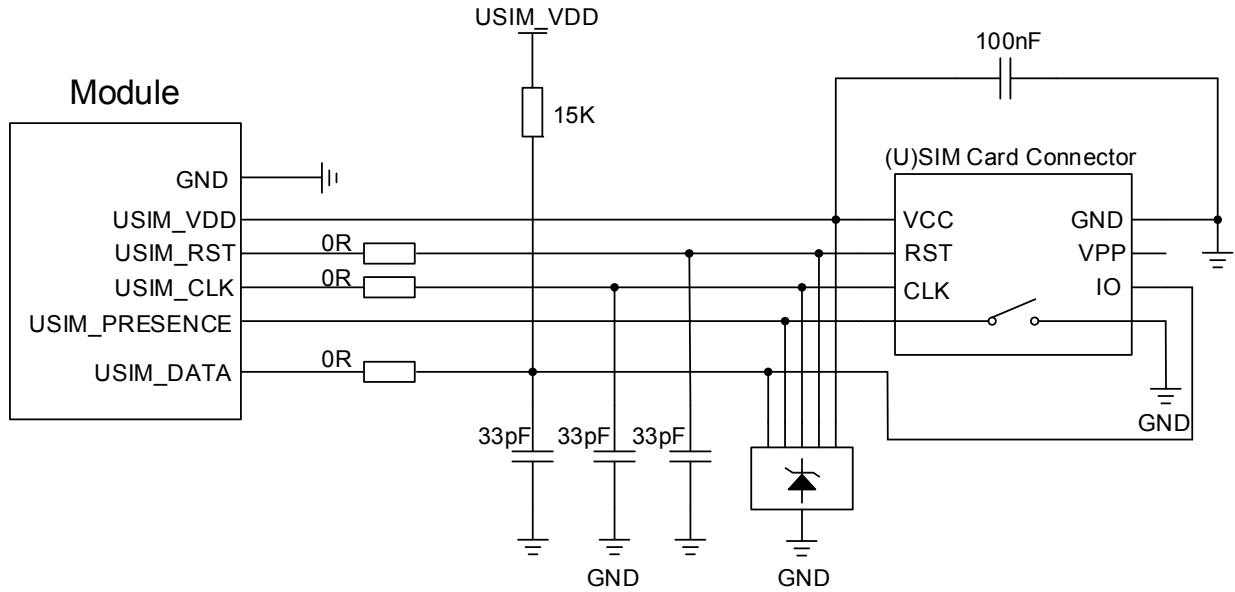

Figure 4: Reference Circuit of (U)SIM Interface with an 8-pin (U)SIM Card Connector

If (U)SIM card detection function is not needed, please keep USIM_PRESENCE unconnected. A reference circuit for (U)SIM interface with a 6-pin (U)SIM card connector is illustrated in the following figure.

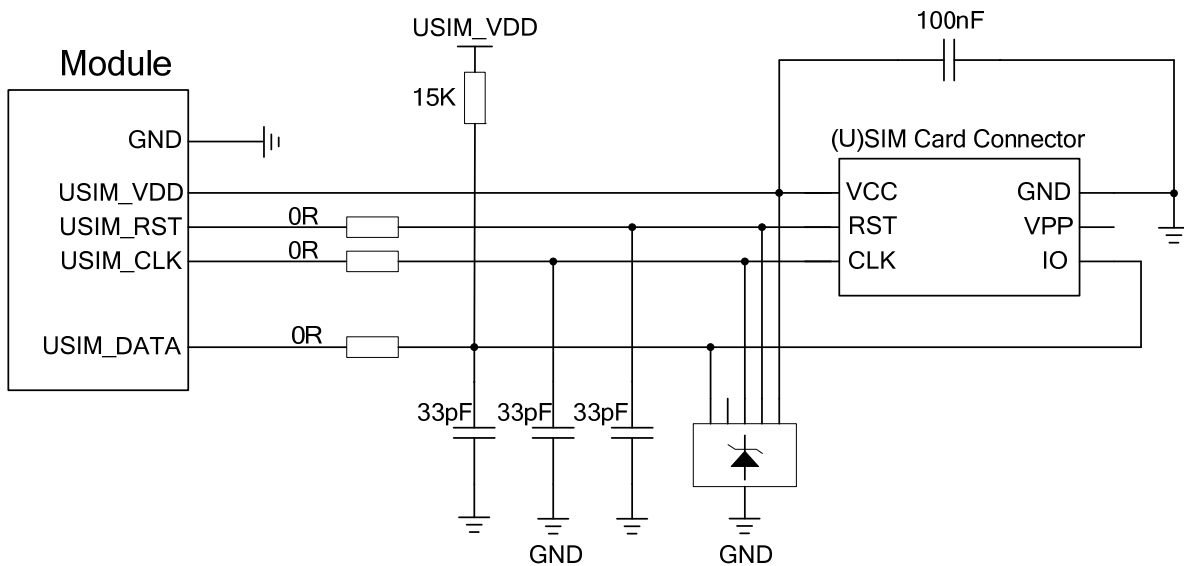

Figure 5: Reference Circuit of (U)SIM Interface with a 6-pin (U)SIM Card Connector

In order to enhance the reliability and availability of the (U)SIM card in customers' applications, please follow the criteria below in (U)SIM circuit design:

- Keep placement of (U)SIM card connector to the module as close as possible. Keep the trace length as less than 200mm as possible.
- Keep (U)SIM card signals away from RF and power supply traces.
- To avoid cross-talk between USIM_DATA and USIM_CLK, keep them away from each other and shield them with surrounded ground.
- In order to offer good ESD protection, it is recommended to add a TVS diode with parasitic capacitance not exceeding 15pF. The 0Ω resistors should be added in series between the module and the (U)SIM card so as to facilitate debugging. The 33pF capacitors are used for filtering interference of EGSM900. Please note that the (U)SIM peripheral circuit should be close to the (U)SIM card connector.
- The pull-up resistor on USIM_DATA line can improve anti-jamming capability when long layout trace and sensitive occasion are applied, and should be placed close to the (U)SIM card connector.

3.5. USB Interface

The following table shows the pin definition of USB interface.

Table 7: Pin Definition of USB Interface

Pin Name	Pin No.	I/O	Description	Comment
USB_DM	36	IO	USB differential data (-)	Require differential impedance of 90Ω
USB_DP	38	IO	USB differential data (+)	Require differential impedance of 90Ω

EC25 Mini PCIe is compliant with USB 2.0 specification. It can only be used as a slave device. Meanwhile, it supports high speed (480Mbps) mode and full speed (12Mbps) mode. The USB interface is used for AT command communication, data transmission, GNSS NMEA output, software debugging, firmware upgrade and voice over USB. The following figure shows a reference circuit of USB interface.

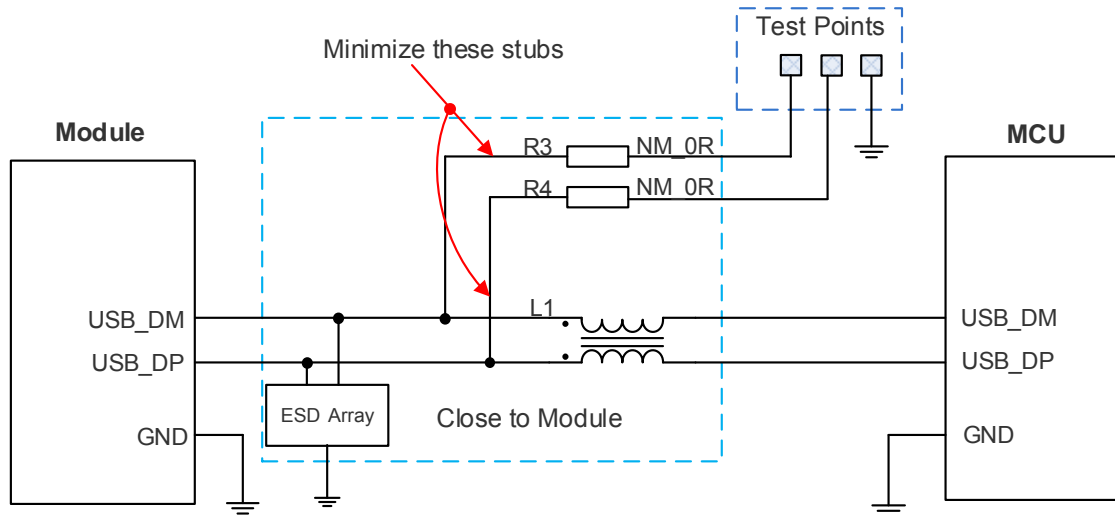

Figure 6: Reference Circuit of USB Interface

A common mode choke L1 is recommended to be added in series between the module and customer's MCU in order to suppress EMI spurious transmission. Meanwhile, the 0Ω resistors (R3 and R4) should be added in series between the module and the test points so as to facilitate debugging, and the resistors are not mounted by default. In order to ensure the integrity of USB data line signal, L1/R3/R4 components must be placed close to the module, and also these resistors should be placed close to each other. The extra stubs of trace must be as short as possible.

The following principles should be complied with when design the USB interface, so as to meet USB 2.0 specification.

- It is important to route the USB signal traces as differential pairs with total grounding. The impedance of USB differential trace is 90Ω.
- Do not route signal traces under crystals, oscillators, magnetic devices and RF signal traces. It is important to route the USB differential traces in inner layer with ground shielding on not only upper and lower layers but also right and left sides.
- Pay attention to the influence of junction capacitance of ESD protection components on USB data lines. Typically, the capacitance value should be less than 2pF.
- Keep the ESD protection components to the USB connector as close as possible.

NOTES

1. There are three preconditions when enabling EC25 Mini PCIe to enter the sleep mode:
 - a) Execute **AT+QSCLK=1** command to enable the sleep mode. Please refer to **document [2]** for details.
 - b) DTR pin should be kept at high level (pulled up internally).
 - c) USB interface on Mini PCIe must be connected with the USB interface of the host and please guarantee the USB of the host is in suspend state.

2. The ESD device used for USB interface protection has been built in the Mini PCIe, thus the external ESD device can be reserved for the further use.

3.6. UART Interfaces

The following table shows the pin definition of the main UART and COEX UART* interfaces.

Table 8: Pin Definition of Main UART Interface

Pin Name	Pin No.	I/O	Power Domain	Description
UART_RX	11	DI	3.3V	UART receive data
UART_TX	13	DO	3.3V	UART transmit data
UART_CTS	23	DI	3.3V	UART clear to send
UART_RTS	25	DO	3.3V	UART request to send

The main UART interface supports 9600bps, 19200bps, 38400bps, 57600bps, 115200bps and 230400bps baud rates, and the default is 115200bps. This interface can be used for AT command communication and data transmission.

Table 9: Pin Definition of COEX UART Interface

Pin No.	Pin Name	I/O	Power Domain	Description
3	COEX_UART_RX	DI	1.8V	LTE/WLAN&BT coexistence signal. It is prohibited to be pulled up to high level before startup.
5	COEX_UART_TX	DO	1.8V	LTE/WLAN&BT coexistence signal. It is prohibited to be pulled up to high level before startup.

NOTES

1. **AT+IPR** command can be used to set the baud rate of the main UART, and **AT+IFC** command can be used to set the hardware flow control (hardware flow control is disabled by default). Please refer to **document [2]** for details.
2. COEX UART interface is not supported on ThreadX modules.
3. “*” means under development.

3.7. PCM and I2C Interfaces

EC25 Mini PCIe provides one Pulse Code Modulation (PCM) digital interface and one I2C interface.

The following table shows the pin definition of PCM and I2C interfaces that can be applied in audio codec design.

Table 10: Pin Definition of PCM and I2C Interfaces

Pin No.	Pin Name	I/O	Power Domain	Description
45	PCM_CLK ¹⁾	IO	1.8V	PCM clock signal
47	PCM_DOUT ¹⁾	DO	1.8V	PCM data output
49	PCM_DIN ¹⁾	DI	1.8V	PCM data input
51	PCM_SYNC ¹⁾	IO	1.8V	PCM frame synchronization
30	I2C_SCL	DO	1.8V	I2C serial clock. Require external pull-up to 1.8V.
32	I2C_SDA	IO	1.8V	I2C serial data. Require external pull-up to 1.8V.

EC25 Mini PCIe provides one PCM digital interface, which supports 16-bit linear data format and the following modes:

- Primary mode (short frame synchronization, works as either master or slave)
- Auxiliary mode (long frame synchronization, works as master only)

NOTE

¹⁾ The digital audio (PCM) function is only supported on **Telematics** version.

In primary mode, the data is sampled on the falling edge of the PCM_CLK and transmitted on the rising edge. The PCM_SYNC falling edge represents the MSB. In this mode, the PCM interface supports 256KHz, 512KHz, 1024KHz or 2048KHz PCM_CLK at 8KHz PCM_SYNC, and also supports 4096KHz PCM_CLK at 16KHz PCM_SYNC. The following figure shows the timing relationship in primary mode with 8KHz PCM_SYNC and 2048KHz PCM_CLK.

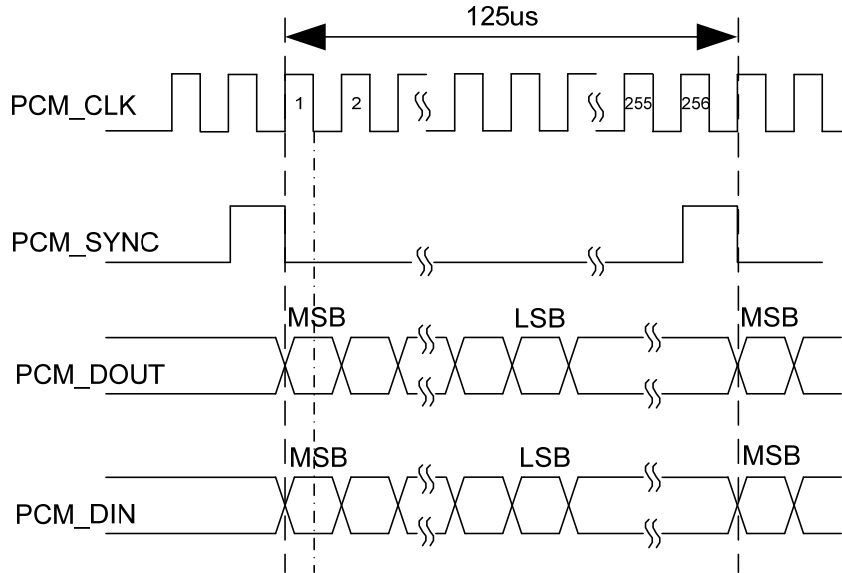

Figure 7: Timing in Primary Mode

In auxiliary mode, the data is sampled on the falling edge of the PCM_CLK and transmitted on the rising edge. The PCM_SYNC rising edge represents the MSB. In this mode, the PCM interface operates with a 256KHz, 512KHz, 1024KHz or 2048KHz PCM_CLK and an 8KHz, 50% duty cycle PCM_SYNC. The following figure shows the timing relationship in auxiliary mode with 8KHz PCM_SYNC and 256KHz PCM_CLK.

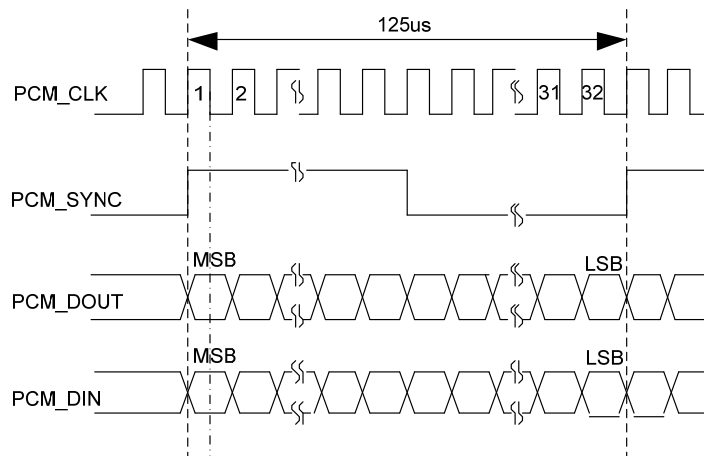

Figure 8: Timing in Auxiliary Mode

Clock and mode can be configured by AT command, and the default configuration is master mode using short frame synchronization format with 2048KHz PCM_CLK and 8KHz PCM_SYNC. In addition, EC25 Mini PCIe's firmware has integrated the configuration on some PCM codec's application with I2C interface. Please refer to **document [2]** for details about **AT+QDAI** command.

The following figure shows a reference design of PCM interface with an external codec IC.

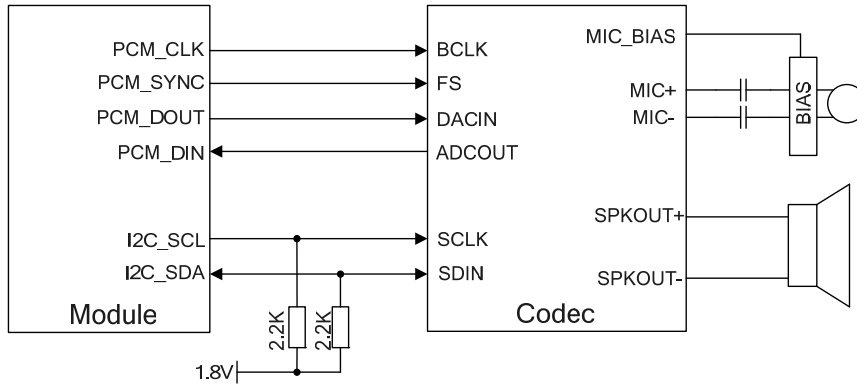

Figure 9: Reference Circuit of PCM Application with Audio Codec

3.8. Control and Indicator Signals

The following table shows the pin definition of control and indicator signals.

Table 11: Pin Definition of Control and Indicator Signals

Pin No.	Pin Name	I/O	Power Domain	Description
17	RI	DO	3.3V	Output signal used to wake up the host
31	DTR	DI	3.3V	Sleep mode control
20	W_DISABLE#	DI	3.3V	Airplane mode control; Pulled up by default; Active low.
22	PERST#	DI	3.3V	Fundamental reset signal; Active low.
42	LED_WWAN#	OC		LED signal for indicating the network status of the module; Active low.
1	WAKE#	OC		Output signal to wake up the host.

3.8.1. RI Signal

The RI signal can be used to wake up the host. When a URC returns, there will be the following behaviors on the RI pin after executing **AT+QCFG="risignalttype","physical"** command.

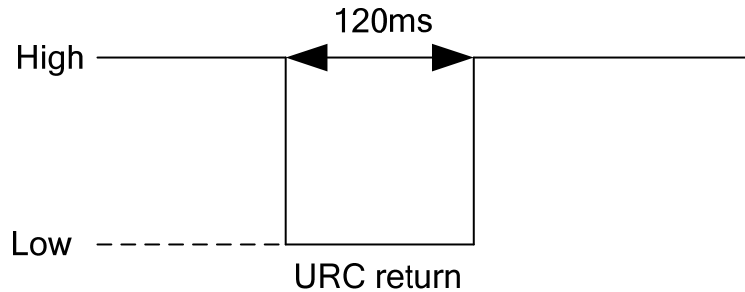

Figure 10: RI Behaviors

3.8.2. DTR Signal

The DTR signal supports sleep control function. Driving it to low level will wake up the module.

3.8.3. W_DISABLE# Signal

EC25 Mini PCIe provides a W_DISABLE# signal to disable or enable the RF function (GNSS not included). W_DISABLE# signal function is disabled by default, and **AT+QCFG="airplanecontrol",1** can be used to enable this function. The W_DISABLE# pin is pulled up by default. Driving it to low level will let the module enter airplane mode.

AT+CFUN can also be used to control the RF status, and the details are as follows:

Table 12: Airplane Mode Controlled by Hardware Method

W_DISABLE#	RF Function Status	Module Operation Mode
High level	RF enabled	Normal mode
Low level	RF disabled	Airplane mode

Software method can be controlled by **AT+CFUN**, and has the same effect with W_DISABLE# signal function, the details are as follows.

Table 13: Airplane Mode Controlled by Software Method

AT+CFUN=?	RF Function Status	Module Operation Mode	Conditions
0	RF and (U)SIM disabled	Minimum functionality mode	Keep W_DISABLE# at high level

3.8.4. PERST# Signal

The PERST# signal can be used to force a hardware reset on the card. Customers can reset the module by driving the PERST# to a low level voltage within the time frame of 150ms~460ms and then releasing it. The reset scenario is illustrated in the following figure.

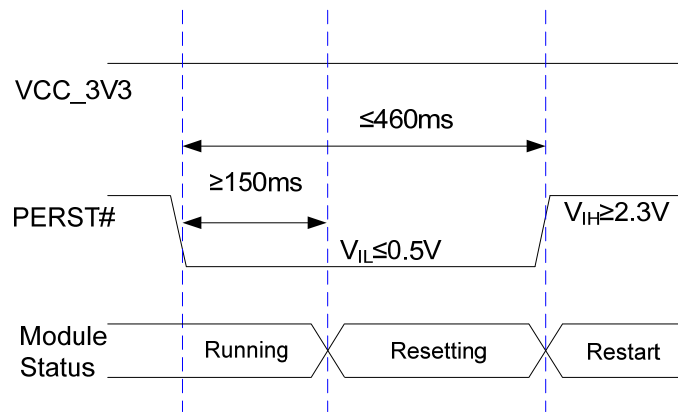

Figure 11: Timing of Resetting Module

3.8.5. LED_WWAN# Signal

The LED_WWAN# signal of EC25 Mini PCIe is used to indicate the network status of the module, and can absorb the current up to 40mA. According to the following circuit, in order to reduce the current of the LED, a resistor must be placed in series with the LED. The LED is emitting light when the LED_WWAN# output signal is active low.

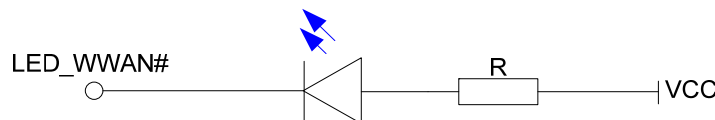

Figure 12: LED_WWAN# Signal Reference Circuit Diagram

There are two indication modes for LED_WWAN# signal to indicate network status, which can be switched through following AT commands:

- AT+QCFG="ledmode",0 (Default setting)
- AT+QCFG="ledmode",2

The following tables show the detailed network status indications of the LED_WWAN# signal.

Table 14: Indications of Network Status (AT+QCFG="ledmode",0, Default Setting)

Pin Status	Description
Flicker slowly (200ms Low/1800ms High)	Network searching
Flicker slowly (1800ms Low/200ms High)	Idle
Flicker quickly (125ms Low/125ms High)	Data transfer is ongoing
Always Low	Voice calling

Table 15: Indications of Network Status (AT+QCFG="ledmode",2)

Pin Status	Description
Low Level (Light on)	Registered on network
High impedance (Light off)	<ul style="list-style-type: none"> ● No network coverage or not registered ● W_DISABLE# signal is at low level. (Disable RF) ● AT+CFUN=0, AT+CFUN=4

3.8.6. WAKE# Signal

The WAKE# signal is an open collector signal which is similar to RI signal, but a host pull-up resistor and **AT+QCFG="risignaltype","physical"** command are required. When a URC returns, a 120ms low level pulse will be outputted. The state of WAKE# signal is shown as below.

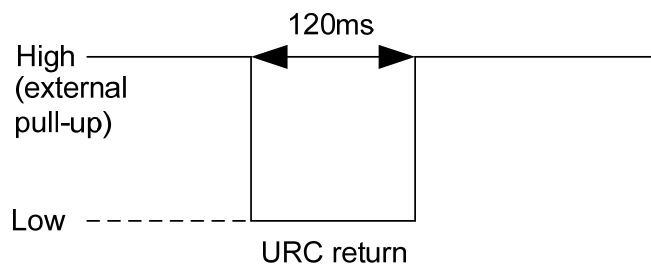

Figure 13: WAKE# Behavior

4 GNSS Receiver

EC25 Mini PCIe includes a fully integrated global navigation satellite system solution that supports Gen8C-Lite of Qualcomm (GPS, GLONASS, BeiDou, Galileo and QZSS).

EC25 Mini PCIe supports standard NMEA-0183 protocol, and outputs NMEA sentences at 1Hz data update rate via USB interface by default.

By default, EC25 Mini PCIe GNSS engine is switched off. It has to be switched on via AT command. For more details about GNSS engine technology and configurations, please refer to **document [3]**.

5 Antenna Connection

EC25 Mini PCIe is mounted with three antenna connectors for external antenna connection: a main antenna connector, an Rx-diversity antenna connector, and a GNSS antenna connector. And Rx-diversity function is enabled by default. The impedance of the antenna connectors is 50Ω.

5.1. Operating Frequency

The following table shows the operating frequencies of EC25 Mini PCIe.

Table 16: Operating Frequencies

3GPP Band	Transmit	Receive	Unit
GSM850	824~849	869~894	MHz
EGSM900	880~915	925~960	MHz
DCS1800	1710~1785	1805~1880	MHz
PCS1900	1850~1910	1930~1990	MHz
WCDMA B1	1920~1980	2110~2170	MHz
WCDMA B2	1850~1910	1930~1990	MHz
WCDMA B4	1710~1755	2110~2155	MHz
WCDMA B5	824~849	869~894	MHz
WCDMA B6	830~840	875~885	MHz
WCDMA B8	880~915	925~960	MHz
WCDMA B19	830~845	875~890	MHz
LTE-FDD B1	1920~1980	2110~2170	MHz
LTE-FDD B2	1850~1910	1930~1990	MHz

LTE-FDD B3	1710~1785	1805~1880	MHz
LTE-FDD B4	1710~1755	2110~2155	MHz
LTE-FDD B5	824~849	869~894	MHz
LTE-FDD B7	2500~2570	2620~2690	MHz
LTE-FDD B8	880~915	925~960	MHz
LTE-FDD B12	699~716	729~746	MHz
LTE-FDD B13	777~787	746~756	MHz
LTE-FDD B14	788~798	758~768	MHz
LTE-FDD B18	815~830	860~875	MHz
LTE-FDD B19	830~845	875~890	MHz
LTE-FDD B20	832~862	791~821	MHz
LTE-FDD B26	814~849	859~894	MHz
LTE-FDD B28	703~748	758~803	MHz
LTE-TDD B38	2570~2620	2570~2620	MHz
LTE-TDD B40	2300~2400	2300~2400	MHz
LTE-TDD B41	2555~2655	2555~2655	MHz
LTE-FDD B66	1710~1780	2100~2200	MHz
LTE-FDD B71	663~698	617~652	MHz

5.2. GNSS Frequency

The following table shows the GNSS frequency of EC25 Mini PCIe.

Table 17: GNSS Frequency

Type	Frequency	Unit
GPS	1575.42±1.023	MHz
GLONASS	1597.5~1605.8	MHz
Galileo	1575.42±2.046	MHz
BeiDou	1561.098±2.046	MHz
QZSS	1575.42	MHz

5.3. GNSS Performance

The following table shows the GNSS performance of EC25 Mini PCIe.

Table 18: GNSS Performance

Parameter	Description	Conditions	Typ.	Unit
Sensitivity (GNSS)	Cold start	Autonomous	-146	dBm
	Reacquisition	Autonomous	-157	dBm
	Tracking	Autonomous	-157	dBm
TTFB (GNSS)	Cold start @open sky	Autonomous	35	s
		XTRA enabled	18	s
	Warm start @open sky	Autonomous	26	s
		XTRA enabled	2.2	s
	Hot start @open sky	Autonomous	2.5	s
		XTRA enabled	1.8	s
Accuracy (GNSS)	CEP-50	Autonomous @open sky	<2.5	m

NOTES

1. Tracking sensitivity: the lowest GNSS signal value at the antenna port on which the module can keep on positioning for 3 minutes.
2. Reacquisition sensitivity: the lowest GNSS signal value at the antenna port on which the module can fix position again within 3 minutes after loss of lock.
3. Cold start sensitivity: the lowest GNSS signal value at the antenna port on which the module fixes position within 3 minutes after executing cold start command.

5.4. Antenna Requirements

5.4.1. Antenna Requirements

The following table shows the requirements on main antenna, Rx-diversity antenna and GNSS antenna.

Table 19: Antenna Requirements

Type	Requirements
GNSS ¹⁾	Frequency range: 1559MHz~1609MHz Polarization: RHCP or linear VSWR: <2 (Typ.) Passive antenna gain: > 0dBi Active antenna noise figure: < 1.5dB Active antenna gain: > 0dBi Active antenna embedded LNA gain: < 17dB
GSM/UMTS/LTE	VSWR: ≤ 2 Efficiency: > 30% Max input power: 50W Input impedance: 50Ω Cable insertion loss: < 1dB (GSM850, EGSM900, WCDMA B5/B6/B8/B19, LTE-FDD B5/B8/B12/B13/B14/B18/B19/B20/B26/B28/B71) Cable insertion loss: < 1.5dB (DCS1800, PCS1900, WCDMA B1/B2/B4, LTE-FDD B1/B2/B3/B4/B66) Cable insertion loss: < 2dB (LTE-FDD B7, LTE-TDD B38/B40/B41)

NOTES

1. It is recommended to use a passive GNSS antenna when LTE B13 or B14 is supported, as the use of active antenna may generate harmonics which will affect the GNSS performance.
2. Since the GNSS port has a 2.85V voltage output, a passive antenna that causes shorting to GND, such as PIFA antenna is not recommended.

5.4.2. Antenna Connectors and Mating Plugs

The dimensions of the antenna connectors are shown as below.

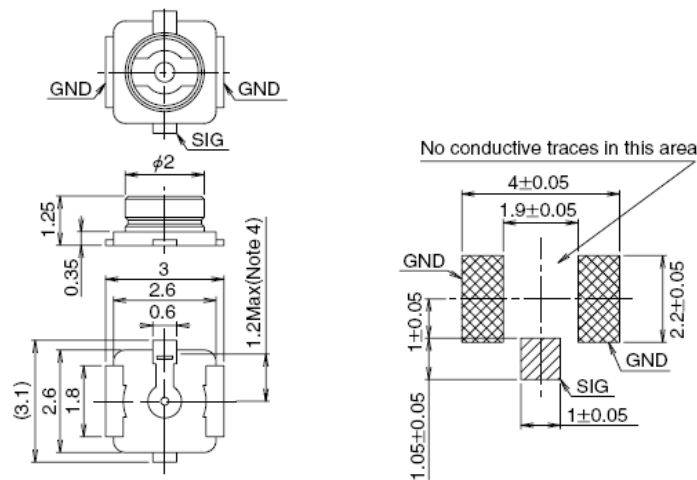

Figure 14: Dimensions of the Antenna Connectors (Unit: mm)

It is recommended to use U.FL-LP mating plugs listed in the following figure to match the antenna connectors.

	U.FL-LP-040	U.FL-LP-066	U.FL-LP(V)-040	U.FL-LP-062	U.FL-LP-088
Part No.					
Mated Height	2.5mm Max. (2.4mm Nom.)	2.5mm Max. (2.4mm Nom.)	2.0mm Max. (1.9mm Nom.)	2.4mm Max. (2.3mm Nom.)	2.4mm Max. (2.3mm Nom.)
Applicable cable	Dia. 0.81mm Coaxial cable	Dia. 1.13mm and Dia. 1.32mm Coaxial cable	Dia. 0.81mm Coaxial cable	Dia. 1mm Coaxial cable	Dia. 1.37mm Coaxial cable
Weight (mg)	53.7	59.1	34.8	45.5	71.7
RoHS	YES				

Figure 15: Mechanicals of U.FL-LP Mating Plugs

The following figure describes the space factor of mating plugs.

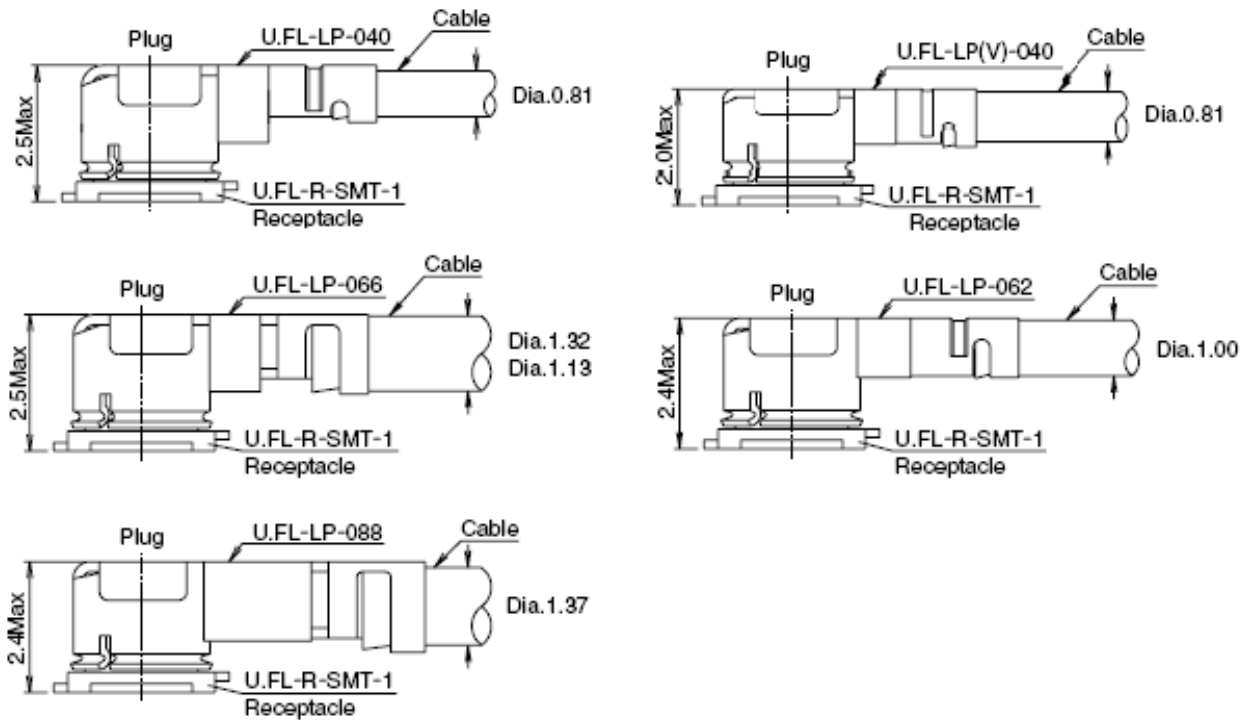

Figure 16: Space Factor of Mating Plugs (Unit: mm)

For more details of the recommended mating plugs, please visit <http://www.hirose.com>.

6 Electrical, Reliability and Radio Characteristics

6.1. General Description

This chapter mainly describes the following electrical and radio characteristics of EC25 Mini PCIe:

- Power supply requirements
- I/O requirements
- RF characteristics
- GNSS receiver
- ESD characteristics
- Current consumption
- Thermal consideration

6.2. Power Supply Requirements

The input voltage of EC25 Mini PCIe is $3.3V \pm 9\%$, as specified by *PCI Express Mini CEM Specifications 1.2*. The following table shows the power supply requirements of EC25 Mini PCIe.

Table 20: Power Supply Requirements

Parameter	Description	Min.	Typ.	Max.	Unit
VCC_3V3	Power supply	3.0	3.3	3.6	V

6.3. I/O Requirements

The following table shows the I/O requirements of EC25 Mini PCIe.

Table 21: I/O Requirements

Parameter	Description	Min.	Max.	Unit
V _{IH}	Input High Voltage	0.7 × VCC_3V3	VCC_3V3 + 0.3	V
V _{IL}	Input Low Voltage	-0.3	0.3 × VCC_3V3	V
V _{OH}	Output High Voltage	VCC_3V3 - 0.5	VCC_3V3	V
V _{OL}	Output Low Voltage	0	0.4	V

NOTES

1. The PCM and I2C interfaces belong to 1.8V power domain and other I/O interfaces belong to VCC_3V3 power domain.
2. The maximum voltage value of V_{IL} for PERST# signal and W_DISABLE# signal is 0.5V.

6.4. RF Characteristics

The following tables show the conducted RF output power and receiving sensitivity of EC25 Mini PCIe module.

Table 22: Conducted RF Output Power of EC25 Mini PCIe

Frequency	Max.	Min.
GSM850/EGSM900	33dBm±2dB	5dBm±5dB
DCS1800/PCS1900	30dBm±2dB	0dBm±5dB
GSM850/EGSM900 (8-PSK)	27dBm±3dB	5dBm±5dB
DCS1800/PCS1900 (8-PSK)	26dBm±3dB	0dBm±5dB
WCDMA bands	24dBm+1/-3dB	< -49dBm

LTE-FDD bands	23dBm±2dB	< -39dBm
LTE-TDD bands	23dBm±2dB	< -39dBm

Table 23: Conducted RF Receiving Sensitivity of EC25-A Mini PCIe

Frequency	Primary	Diversity	SIMO ¹⁾	3GPP (SIMO)
WCDMA B2	-110.0dBm	/	/	-104.7dBm
WCDMA B4	-110.0dBm	/	/	-106.7dBm
WCDMA B5	-110.5dBm	/	/	-104.7dBm
LTE-FDD B2 (10MHz)	-98.0dBm	-98.0dBm	-101.0dBm	-94.3dBm
LTE-FDD B4 (10MHz)	-97.5dBm	-99.0dBm	-101.0dBm	-96.3dBm
LTE-FDD B12 (10MHz)	-97.2dBm	-98.0dBm	-101.0dBm	-93.3dBm

Table 24: Conducted RF Receiving Sensitivity of EC25-AU Mini PCIe

Frequency	Primary	Diversity	SIMO ¹⁾	3GPP (SIMO)
GSM850	-109.0dBm	/	/	-102.0dBm
EGSM900	-109.0dBm	/	/	-102.0dBm
DCS1800	-109.0dBm	/	/	-102.0dBm
PCS1900	-109.0dBm	/	/	-102.0dBm
WCDMA B1	-110.0dBm	-109dBm	-112dBm	-106.7dBm
WCDMA B2	-110.0dBm	/	/	-104.7dBm
WCDMA B5	-111.0dBm	-112dBm	-113dBm	-104.7dBm
WCDMA B8	-111.0dBm	-111dBm	-113dBm	-103.7dBm
LTE-FDD B1 (10MHz)	-97.2dBm	-97.5dBm	-100.2dBm	-96.3dBm
LTE-FDD B2 (10MHz)	-98.2dBm	/	/	-94.3dBm
LTE-FDD B3 (10MHz)	-98.7dBm	-98.6dBm	-102.2dBm	-93.3dBm

LTE-FDD B4 (10MHz)	-97.7dBm	-97.4dBm	-100.2dBm	-96.3dBm
LTE-FDD B5 (10MHz)	-98.0dBm	-98.2dBm	-101.0dBm	-94.3dBm
LTE-FDD B7 (10MHz)	-97.7dBm	-97.7dBm	-101.2dBm	-94.3dBm
LTE-FDD B8 (10MHz)	-99.2dBm	-98.2dBm	-102.2dBm	-93.3dBm
LTE-FDD B28 (10MHz)	-98.6dBm	-98.7dBm	-102.0dBm	-94.8dBm
LTE-TDD B40 (10MHz)	-97.2dBm	-98.4dBm	-101.2dBm	-96.3dBm

Table 25: Conducted RF Receiving Sensitivity of EC25-J Mini PCIe

Frequency	Primary	Diversity	SIMO ¹⁾	3GPP (SIMO)
WCDMA B1	-110.0dBm	/	/	-106.7dBm
WCDMA B6	-110.5dBm	/	/	-106.7dBm
WCDMA B8	-110.5dBm	/	/	-103.7dBm
WCDMA B19	-110.5dBm	/	/	-106.7dBm
LTE-FDD B1 (10MHz)	-97.5dBm	-98.7dBm	-100.2dBm	-96.3dBm
LTE-FDD B3 (10MHz)	-96.5dBm	-97.1dBm	-100.5dBm	-93.3dBm
LTE-FDD B8 (10MHz)	-98.4dBm	-99.0dBm	-101.2dBm	-93.3dBm
LTE-FDD B18 (10MHz)	-99.5dBm	-99.0dBm	-101.7dBm	-96.3dBm
LTE-FDD B19 (10MHz)	-99.2dBm	-99.0dBm	-101.4dBm	-96.3dBm
LTE-FDD B26 (10MHz)	-99.5dBm	-99.0dBm	-101.5dBm	-93.8dBm
LTE-TDD B41 (10MHz)	-95.0dBm	-95.7dBm	-99.0dBm	-94.3dBm

Table 26: Conducted RF Receiving Sensitivity of EC25-E Mini PCIe

Frequency	Primary	Diversity	SIMO ¹⁾	3GPP (SIMO)
EGSM900	-109.0dBm	/	/	-102.0dBm
DCS1800	-109.0dBm	/	/	-102.0dbm

WCDMA B1	-110.5dBm	/	/	-106.7dBm
WCDMA B5	-110.5dBm	/	/	-104.7dBm
WCDMA B8	-110.5dBm	/	/	-103.7dBm
LTE-FDD B1 (10MHz)	-98.0dBm	-98.0dBm	-101.5dBm	-96.3dBm
LTE-FDD B3 (10MHz)	-96.5dBm	-98.5dBm	-101.5dBm	-93.3dBm
LTE-FDD B5 (10MHz)	-98.0dBm	-98.5dBm	-101.0dBm	-94.3dBm
LTE-FDD B7 (10MHz)	-97.0dBm	-97.0dBm	-99.5dBm	-94.3dBm
LTE-FDD B8 (10MHz)	-97.0dBm	-97.0dBm	-101.0dBm	-93.3dBm
LTE-FDD B20 (10MHz)	-97.5dBm	-99.0dBm	-102.5dBm	-93.3dBm
LTE-TDD B38 (10MHz)	-95.0dBm	-97.0dBm	-98.9dBm	-96.3dBm
LTE-TDD B40 (10MHz)	-96.3dBm	-98.0dBm	-101.0dBm	-96.3dBm
LTE-TDD B41 (10MHz)	-94.5dBm	-97.0dBm	-98.5dBm	-94.3dBm

Table 27: Conducted RF Receiving Sensitivity of EC25-V Mini PCIe

Frequency	Primary	Diversity	SIMO ¹⁾	3GPP (SIMO)
LTE-FDD B4 (10MHz)	-97.5dBm	-99.0dBm	-101.0dBm	-96.3dBm
LTE-FDD B13 (10MHz)	-97.7dBm	-97.0dBm	-100.0dBm	-93.3dBm

Table 28: Conducted RF Receiving Sensitivity of EC25-AF Mini PCIe

Frequency	Primary	Diversity	SIMO ¹⁾	3GPP (SIMO)
WCDMA B2	-109.5dBm	-110dBm	-110.4dBm	-104.7dBm
WCDMA B4	-109.6dBm	-110dBm	-110.6dBm	-106.7dBm
WCDMA B5	-110.5dBm	-110dBm	-110.7dBm	-104.7dBm
LTE-FDD B2 (10MHz)	-98.0dBm	-98.5dBm	-100.5dBm	-94.3dBm
LTE-FDD B4 (10MHz)	-97.5dBm	-98.2dBm	-99.5dBm	-93.3dBm

LTE-FDD B5 (10MHz)	-98.0dBm	-98.5dBm	-100.5dBm	-94.3dBm
LTE-FDD B12 (10MHz)	-99.0dBm	-99.5dBm	-100.5dBm	-93.3dBm
LTE-FDD B13 (10MHz)	-98.5dBm	-99.5dBm	-100.7dBm	-93.3dBm
LTE-FDD B14 (10MHz)	-99.4dBm	-99.5dBm	-100.9dBm	-93.3dBm
LTE-FDD B66 (10MHz)	-97.5dBm	-98.5dBm	-99.6dBm	-95.8dBm
LTE-FDD B71 (10MHz)	-98.6dBm	-99.5dBm	-100dBm	-93.5dBm

Table 29: Conducted RF Receiving Sensitivity of EC25-AFX Mini PCIe

Frequency	Primary	Diversity	SIMO ¹⁾	3GPP (SIMO)
WCDMA B2	-109.6dBm	-110	-110.4	-104.7dBm
WCDMA B4	-109.6dBm	-110	-110.6	-106.7dBm
WCDMA B5	-110.5dBm	-110	-110.7	-104.7dBm
LTE-FDD B2 (10MHz)	-98.0dBm	-98.5dBm	-100.5dBm	-94.3dBm
LTE-FDD B4 (10MHz)	-97.6dBm	-98.2dBm	-99.5dBm	-93.3dBm
LTE-FDD B5 (10MHz)	-98.0dBm	-98.5dBm	-100.5dBm	-94.3dBm
LTE-FDD B12 (10MHz)	-99.0dBm	-99.5dBm	-100.5dBm	-93.3dBm
LTE-FDD B13 (10MHz)	-98.5dBm	-99.7dBm	-100.8dBm	-93.3dBm
LTE-FDD B14 (10MHz)	-99.4dBm	-99.5dBm	-100.9dBm	-93.3dBm
LTE-FDD B66 (10MHz)	-97.5dBm	-98.5dBm	-99.6dBm	-95.8dBm
LTE-FDD B71 (10MHz)	-98.8dBm	-99.7dBm	-100.5dBm	-93.5dBm

Table 30: Conducted RF Receiving Sensitivity of EC25-EU Mini PCIe

Frequency	Primary	Diversity	SIMO ¹⁾	3GPP (SIMO)
EGSM900	-108dBm	/	/	-102.0dBm
DCS1800	-108.6dBm	/	/	-102.0dbm

WCDMA B1	-110dBm	-109dBm	/	-106.7dBm
WCDMA B8	-110dBm	-111dBm	/	-103.7dBm
LTE-FDD B1 (10MHz)	-98.2dBm	-99.0dBm	-101.2dBm	-96.3dBm
LTE-FDD B3 (10MHz)	-97.7dBm	-99.8dBm	-101.0dBm	-93.3dBm
LTE-FDD B7 (10MHz)	-96.7dBm	-98.5dBm	-100.2dBm	-94.3dBm
LTE-FDD B8 (10MHz)	-98.2dBm	-100.4dBm	-101.7 dBm	-93.3dBm
LTE-FDD B20 (10MHz)	-98.2dBm	-100.8dBm	-101.7dBm	-93.3dBm
LTE-FDD B28 (10MHz)	-98.2dBm	-100.5dBm	-101.7dBm	-94.8dBm
LTE-TDD B38 (10MHz)	-95dBm	-97.0dBm	-99.7dBm	-96.3dBm
LTE-TDD B40 (10MHz)	-95.9dBm	-98.0dBm	-100.2dBm	-96.3dBm
LTE-TDD B41 (10MHz)	-94.8dBm	-97.0dBm	-99.7dBm	-94.3dBm

Table 31: Conducted RF Receiving Sensitivity of EC25-EC Mini PCIe

Frequency	Primary	Diversity	SIMO ¹⁾	3GPP (SIMO)
EGSM900	-108.8dBm	/	/	-102.0dBm
DCS1800	-109.0dBm	/	/	-102.0dbm
WCDMA B1	-110.5dBm	/	/	-106.7dBm
WCDMA B8	-110.5dBm	/	/	-103.7dBm
LTE-FDD B1 (10MHz)	-98.0dBm	-98.0dBm	-101.0dBm	-96.3dBm
LTE-FDD B3 (10MHz)	-96.5dBm	-98.5dBm	-100.0dBm	-93.3dBm
LTE-FDD B7 (10MHz)	-97.0dBm	-95.5dBm	-99.5dBm	-94.3dBm
LTE-FDD B8 (10MHz)	-97.0dBm	-97.0dBm	-101.0dBm	-93.3dBm
LTE-FDD B20 (10MHz)	-97.5dBm	-99.0dBm	-101.0dBm	-93.3dBm
LTE-FDD B28 (10MHz)	-98.6dBm	-98.7dBm	-101.5dBm	-94.8dBm

Table 32: Conducted RF Receiving Sensitivity of EC25-EUX Mini PCIe

Frequency	Primary	Diversity	SIMO ¹⁾	3GPP (SIMO)
EGSM900	-109.0dBm	/	/	-102.0dBm
DCS1800	-109.0dBm	/	/	-102.0dbm
WCDMA B1	-110.5dBm	/	/	-106.7dBm
WCDMA B8	-110.5dBm	/	/	-103.7dBm
LTE-FDD B1 (10MHz)	-98.0dBm	-98.0dBm	-101dBm	-96.3dBm
LTE-FDD B3 (10MHz)	-96.5dBm	-98.5dBm	-99.5dBm	-93.3dBm
LTE-FDD B7 (10MHz)	-97.0dBm	-94.5dBm	-99.5dBm	-94.3dBm
LTE-FDD B8 (10MHz)	-97.0dBm	-97.0dBm	-100.0dBm	-93.3dBm
LTE-FDD B20 (10MHz)	-97.5dBm	-99.0dBm	-101.5dBm	-93.3dBm
LTE-FDD B28 (10MHz)	-98.6dBm	-98.7dBm	-101.0dBm	-94.8dBm
LTE-TDD B38 (10MHz)	-96.3dBm	-97dBm	-98.5dBm	-96.3dBm
LTE-TDD B40 (10MHz)	-96.9dBm	-98.0dBm	-99.1dBm	-96.3dBm
LTE-TDD B41 (10MHz)	-95.3dBm	-97.5dBm	-98.0dBm	-94.3dBm

Table 33: Conducted RF Receiving Sensitivity of EC25-MX Mini PCIe

Frequency	Primary	Diversity	SIMO ¹⁾	3GPP (SIMO)
WCDMA B2	-110dBm	-110dBm	/	-104.7dBm
WCDMA B4	-109.5dBm	-110dBm	/	-106.7dBm
WCDMA B5	-110dBm	-110dBm	/	-104.7dBm
LTE-FDD B2 (10MHz)	-98.2dBm	-99.1dBm	-101.5dBm	-94.3dBm
LTE-FDD B4 (10MHz)	-97.2dBm	-98.2dBm	-101.2dBm	-96.3dBm
LTE-FDD B5 (10MHz)	-98.2dBm	-99.2dBm	-102.2dBm	-94.3dBm
LTE-FDD B7 (10MHz)	-95.7dBm	-98.5dBm	-100.2dBm	-94.3dBm

LTE-FDD B28 (10MHz)	-97.2dBm	-99.3dBm	-101.7dBm	-94.8dBm
LTE-FDD B66 (10MHz)	-97.2dBm	-98.4dBm	-101.2dBm	-95.8dBm

Table 34: Conducted RF Receiving Sensitivity of EC25-AUX Mini PCIe

Frequency	Primary	Diversity	SIMO ¹⁾	3GPP (SIMO)
GSM850	-109.0dBm	/	/	-102.0dBm
EGSM900	-109.0dBm	/	/	-102.0dBm
DCS1800	-109.0dBm	/	/	-102.0dBm
PCS1900	-109.0dBm	/	/	-102.0dBm
WCDMA B1	-110.0dBm	-109.5dBm	-112dBm	-106.7dBm
WCDMA B2	-110.5dBm	/	/	-104.7dBm
WCDMA B4	-110.0dBm	-110dBm	-112dBm	-104.7dBm
WCDMA B5	-111.0dBm	-112dBm	-113dBm	-104.7dBm
WCDMA B8	-111.0dBm	-112dBm	-113dBm	-103.7dBm
LTE-FDD B1 (10MHz)	-98.0dBm	-97.7dBm	-101.2dBm	-96.3dBm
LTE-FDD B2 (10MHz)	-98.5dBm	/	/	-94.3dBm
LTE-FDD B3 (10MHz)	-99.0dBm	-98.8dBm	-102.2dBm	-93.3dBm
LTE-FDD B4 (10MHz)	-97.7dBm	-97.6dBm	-100.2dBm	-96.3dBm
LTE-FDD B5 (10MHz)	-98.5dBm	-98.2dBm	-101.0dBm	-94.3dBm
LTE-FDD B7 (10MHz)	-97.7dBm	-97.7dBm	-101.2dBm	-94.3dBm
LTE-FDD B8 (10MHz)	-99.0dBm	-98.5dBm	-102.2dBm	-93.3dBm
LTE-FDD B28 (10MHz)	-98.0dBm	-98.7dBm	-101.5dBm	-94.8dBm
LTE-TDD B40 (10MHz)	-97.5dBm	-98.2dBm	-101.2dBm	-96.3dBm

NOTE

¹⁾ SIMO is a smart antenna technology that uses a single antenna at the transmitter side and two antennas at the receiver side, which can improve RX performance.

6.5. ESD Characteristics

The following table shows the ESD characteristics of EC25 Mini PCIe.

Table 35: ESD Characteristics of EC25 Mini PCIe

Tested Interfaces	Contact Discharge	Air Discharge	Unit
Power Supply and GND	+/-5	+/-10	kV
Antenna Interfaces	+/-4	+/-8	kV
USB Interface	+/-4	+/-8	kV
(U)SIM Interface	+/-4	+/-8	kV
Others	+/-0.5	+/-1	kV

6.6. Current Consumption

The following tables describe the current consumption of EC25 Mini PCIe series module.

Table 36: Current Consumption of EC25-A Mini PCIe

Parameter	Description	Conditions	Typ.	Unit
I _{VBAT}	Sleep state	AT+CFUN=0 (USB disconnected)	3.6	mA
		WCDMA PF=64 (USB disconnected)	4.4	mA
		WCDMA PF=128 (USB disconnected)	3.8	mA
		LTE-FDD PF=64 (USB disconnected)	5.9	mA
		LTE-FDD PF=128 (USB disconnected)	4.8	mA

Idle state	WCDMA PF=64 (USB disconnected)	27.0	mA
	WCDMA PF=64 (USB connected)	40.0	mA
	LTE-FDD PF=64 (USB disconnected)	43.0	mA
	LTE-FDD PF=64 (USB connected)	59.0	mA
WCDMA data transfer (GNSS OFF)	WCDMA B2 HSDPA @22.63dBm	764.0	mA
	WCDMA B2 HSUPA @23.19dBm	741.0	mA
	WCDMA B4 HSDPA @22.45dBm	745.0	mA
	WCDMA B4 HSUPA @22.57dBm	752.0	mA
	WCDMA B5 HSDPA @22.49dBm	616.0	mA
	WCDMA B5 HSUPA @22.43dBm	637.0	mA
LTE data transfer (GNSS OFF)	LTE-FDD B2 @22.92dBm	977.0	mA
	LTE-FDD B4 @23.42dBm	1094.0	mA
	LTE-FDD B12 @23.39dBm	847.0	mA
WCDMA voice call	WCDMA B2 @23.59dBm	861.0	mA
	WCDMA B4 @23.47dBm	812.0	mA
	WCDMA B5 @23.46dBm	683.0	mA

Table 37: Current Consumption of EC25-AU Mini PCIe

Parameter	Description	Conditions	Typ.	Unit
I _{BAT}	Sleep state	AT+CFUN=0 (USB disconnected)	2.6	mA
		GSM DRX=2 (USB disconnected)	4.3	mA
		GSM DRX=9 (USB disconnected)	3.1	mA
		WCDMA PF=64 (USB disconnected)	3.8	mA
		WCDMA PF=128 (USB disconnected)	3.3	mA
		LTE-FDD PF=64 (USB disconnected)	4.2	mA

	LTE-FDD PF=128 (USB disconnected)	3.5	mA	
	LTE-TDD PF=64 (USB disconnected)	4.5	mA	
	LTE-TDD PF=128 (USB disconnected)	3.7	mA	
Idle state	GSM DRX=5 (USB disconnected)	22.0	mA	
	GSM DRX=5 (USB connected)	34.0	mA	
	WCDMA PF=64 (USB disconnected)	22.0	mA	
	WCDMA PF=64 (USB connected)	33.0	mA	
	LTE-FDD PF=64 (USB disconnected)	29.0	mA	
	LTE-FDD PF=64 (USB connected)	42.0	mA	
	LTE-TDD PF=64 (USB disconnected)	30.0	mA	
	LTE-TDD PF=64 (USB connected)	42.0	mA	
	GPRS data transfer (GNSS OFF)	EGSM900 4DL/1UL @33.10dBm	385.0	mA
		EGSM900 3DL/2UL @32.93dBm	631.0	mA
EGSM900 2DL/3UL @31.15dBm		730.0	mA	
EGSM900 1DL/4UL @29.94dBm		830.0	mA	
DCS1800 4DL/1UL @30.35dBm		255.0	mA	
DCS1800 3DL/2UL @30.25dBm		392.0	mA	
DCS1800 2DL/3UL @30.18dBm		527.0	mA	
DCS1800 1DL/4UL @29.93dBm		667.0	mA	
EDGE data transfer (GNSS OFF)	EGSM900 4DL/1UL @27.54dBm	264.0	mA	
	EGSM900 3DL/2UL @27.38dBm	368.0	mA	
	EGSM900 2DL/3UL @27.27dBm	498.0	mA	
	EGSM900 1DL/4UL @27.17dBm	634.0	mA	
	DCS1800 4DL/1UL @27.64dBm	223.0	mA	
	DCS1800 3DL/2UL @27.45dBm	333.0	mA	

	DCS1800 2DL/3UL @27.34dBm	449.0	mA
	DCS1800 1DL/4UL @27.29dBm	573.0	mA
	WCDMA B1 HSDPA @22.45dBm	815.0	mA
	WCDMA B1 HSUPA @21.75dBm	804.0	mA
WCDMA data transfer (GNSS OFF)	WCDMA B5 HSDPA @22.41dBm	755.0	mA
	WCDMA B5 HSUPA @22.13dBm	775.0	mA
	WCDMA B8 HSDPA @21.34dBm	619.0	mA
	WCDMA B8 HSUPA @21.07dBm	634.0	mA
LTE data transfer (GNSS OFF)	LTE-FDD B1 @23.39dBm	1055.0	mA
	LTE-FDD B3 @22.26dBm	967.0	mA
	LTE-FDD B5 @22.27dBm	814.0	mA
	LTE-FDD B8 @22.21dBm	817.0	mA
	LTE-TDD B40 @22.62dBm	568.0	mA
GSM voice call	EGSM900 PCL=5 @33.24dBm	368.0	mA
	DCS1800 PCL=0 @30.13dBm	223.0	mA
WCDMA voice call	WCDMA B1 @23.20dBm	883.0	mA
	WCDMA B5 @22.82dBm	782.0	mA
	WCDMA B8 @22.99dBm	677.0	mA

Table 38: Current Consumption of EC25-J Mini PCIe

Parameter	Description	Conditions	Typ.	Unit
I _{VBAT}	Sleep state	AT+CFUN=0 (USB disconnected)	3.2	mA
		WCDMA PF=64 (USB disconnected)	4.3	mA
		WCDMA PF=128 (USB disconnected)	3.8	mA
		LTE-FDD PF=64 (USB disconnected)	5.0	mA

	LTE-FDD PF=128 (USB disconnected)	4.4	mA
	LTE-TDD PF=64 (USB disconnected)	5.1	mA
	LTE-TDD PF=128 (USB disconnected)	4.4	mA
Idle state	WCDMA PF=64 (USB disconnected)	31.5	mA
	WCDMA PF=64 (USB connected)	43.5	mA
	LTE-FDD PF=64 (USB disconnected)	32.3	mA
	LTE-FDD PF=64 (USB connected)	45.4	mA
	LTE-TDD PF=64 (USB disconnected)	32.3	mA
	LTE-TDD PF=64 (USB connected)	43.3	mA
	WCDMA B1 HSDPA @22.55dBm	829.0	mA
	WCDMA B1 HSUPA @22.25dBm	848.2	mA
WCDMA data transfer (GNSS OFF)	WCDMA B6 HSDPA @22.79dBm	649.2	mA
	WCDMA B6 HSUPA @22.59dBm	661.4	mA
	WCDMA B8 HSDPA @22.71dBm	691.0	mA
	WCDMA B8 HSUPA @22.63dBm	700.0	mA
	WCDMA B19 HSDPA @22.77dBm	644.2	mA
	WCDMA B19 HSUPA @22.53dBm	657.6	mA
	LTE-FDD B1 @23.15dBm	1045.0	mA
LTE data transfer (GNSS OFF)	LTE-FDD B3 @23.29dBm	1070.0	mA
	LTE-FDD B8 @23.29dBm	867.3	mA
	LTE-FDD B18 @23.82dBm	947.7	mA
	LTE-FDD B19 @23.78dBm	955.1	mA
	LTE-FDD B26 @23.22dBm	924.9	mA
	LTE-TDD B41 @22.95dBm	609.6	mA
WCDMA	WCDMA B1 @23.39dBm	969.6	mA

voice call	WCDMA B6 @23.36dBm	692.3	mA
	WCDMA B8 @23.54dBm	763.9	mA
	WCDMA B19 @23.29dBm	682.1	mA

Table 39: Current Consumption of EC25-E Mini PCIe

Parameter	Description	Conditions	Typ.	Unit
I _V BAT	Sleep state	AT+CFUN=0 (USB disconnected)	3.9	mA
		GSM DRX=2 (USB disconnected)	5.1	mA
		GSM DRX=9 (USB disconnected)	4.3	mA
		WCDMA PF=64 (USB disconnected)	5.5	mA
		WCDMA PF=128 (USB disconnected)	4.8	mA
		LTE-FDD PF=64 (USB disconnected)	5.8	mA
		LTE-FDD PF=128 (USB disconnected)	5.0	mA
		LTE-TDD PF=64 (USB disconnected)	5.8	mA
		LTE-TDD PF=128 (USB disconnected)	4.9	mA
	Idle state	GSM DRX=5 (USB disconnected)	30.0	mA
		GSM DRX=5 (USB connected)	43.0	mA
		WCDMA PF=64 (USB disconnected)	31.0	mA
		WCDMA PF=64 (USB connected)	45.0	mA
		LTE-FDD PF=64 (USB disconnected)	31.0	mA
		LTE-FDD PF=64 (USB connected)	44.0	mA
LTE-TDD PF=64 (USB disconnected)		32.0	mA	
LTE-TDD PF=64 (USB connected)		44.0	mA	
GPRS data transfer (GNSS OFF)	EGSM900 4DL/1UL @33.08dBm	372.0	mA	
	EGSM900 3DL/2UL @31.03dBm	626.0	mA	

	EGSM900 2DL/3UL @29.86dBm	706.0	mA
	EGSM900 1DL/4UL @29.44dBm	767.0	mA
	DCS1800 4DL/1UL @30.39dBm	262.0	mA
	DCS1800 3DL/2UL @30.19dBm	417.0	mA
	DCS1800 2DL/3UL @30.02dBm	564.0	mA
	DCS1800 1DL/4UL @29.86dBm	709.0	mA
	EGSM900 4DL/1UL @27.59dBm	233.0	mA
	EGSM900 3DL/2UL @27.45dBm	370.0	mA
	EGSM900 2DL/3UL @27.31dBm	500.0	mA
EDGE data transfer (GNSS OFF)	EGSM900 1DL/4UL @27.14dBm	623.0	mA
	DCS1800 4DL/1UL @26.24dBm	224.0	mA
	DCS1800 3DL/2UL @26.13dBm	334.0	mA
	DCS1800 2DL/3UL @25.97dBm	440.0	mA
	DCS1800 1DL/4UL @25.82dBm	553.0	mA
	WCDMA B1 HSDPA @22.49dBm	798.0	mA
	WCDMA B1 HSUPA @21.87dBm	788.0	mA
WCDMA data transfer (GNSS OFF)	WCDMA B5 HSDPA @22.66dBm	781.0	mA
	WCDMA B5 HSUPA @21.99dBm	770.0	mA
	WCDMA B8 HSDPA @22.23dBm	655.0	mA
	WCDMA B8 HSUPA @21.68dBm	659.0	mA
	LTE-FDD B1 @23.12dBm	940.0	mA
LTE data transfer (GNSS OFF)	LTE-FDD B3 @22.75dBm	989.0	mA
	LTE-FDD B5 @22.92dBm	962.0	mA
	LTE-FDD B7 @23.42dBm	1188.0	mA
	LTE-FDD B8 @22.97dBm	911.0	mA

	LTE-FDD B20 @22.51dBm	946.0	mA
	LTE-TDD B38 @22.58dBm	686.0	mA
	LTE-TDD B40 @22.31dBm	576.0	mA
	LTE-TDD B41 @22.03dBm	611.0	mA
GSM voice call	EGSM900 PCL=5 @33.31dBm	367.0	mA
	DCS1800 PCL=0 @29.48dBm	248.0	mA
WCDMA voice call	WCDMA B1 @23.18dBm	868.0	mA
	WCDMA B5 @22.62dBm	808.0	mA
	WCDMA B8 @23.02dBm	728.0	mA

Table 40: Current Consumption of EC25-V Mini PCIe

Parameter	Description	Conditions	Typ.	Unit
I _V BAT	Sleep state	AT+CFUN=0 (USB disconnected)	3.4	mA
		LTE-FDD PF=64 (USB disconnected)	4.8	mA
		LTE-FDD PF=128 (USB disconnected)	4.3	mA
	Idle state	LTE-FDD PF=64 (USB disconnected)	30.0	mA
		LTE-FDD PF=64 (USB connected)	42.0	mA
	LTE data transfer (GNSS OFF)	LTE-FDD B4 @23.3dBm	873.0	mA
		LTE-FDD B13 @22.13dBm	638.0	mA

Table 41: Current Consumption of EC25-AF Mini PCIe

Parameter	Description	Conditions	Typ.	Unit
I _V BAT	Sleep state	AT+CFUN=0 (USB disconnected)	2.2	mA
		WCDMA PF=64 (USB disconnected)	3.1	mA
		WCDMA PF=128 (USB disconnected)	2.8	mA

	LTE-FDD PF=64 (USB disconnected)	3.7	mA
	LTE-FDD PF=128 (USB disconnected)	3.1	mA
Idle state	WCDMA PF=64 (USB disconnected)	21.7	mA
	WCDMA PF=64 (USB connected)	32.5	mA
	LTE-FDD PF=64 (USB disconnected)	25.0	mA
	LTE-FDD PF=64 (USB connected)	38.0	mA
	WCDMA B2 HSDPA @22.63dBm	560.0	mA
	WCDMA B2 HSUPA @22.49dBm	564.0	mA
WCDMA data transfer (GNSS OFF)	WCDMA B4 HSDPA @22.45dBm	601.0	mA
	WCDMA B4 HSUPA @22.57dBm	610.0	mA
	WCDMA B5 HSDPA @22.49dBm	603.0	mA
	WCDMA B5 HSUPA @22.43dBm	617.0	mA
	LTE-FDD B2 @22.92dBm	758.0	mA
	LTE-FDD B4 @23.12dBm	770.0	mA
LTE data transfer (GNSS OFF)	LTE-FDD B5 @22.98dBm	700.0	mA
	LTE-FDD B12 @23.42dBm	808.0	mA
	LTE-FDD B13 @22.92dBm	790.0	mA
	LTE-FDD B14 @23.42dBm	795.0	mA
	LTE-FDD B66 @23.35dBm	816.0	mA
	LTE-FDD B71 @23.39dBm	801.0	mA
WCDMA voice call	WCDMA B2 @23.59dBm	585.0	mA
	WCDMA B4 @23.47dBm	610.0	mA
	WCDMA B5 @23.46dBm	605.0	mA

Table 42: Current Consumption of EC25-EUX Mini PCIe

Parameter	Description	Conditions	Typ.	Unit	
I _{BAT}	OFF state	Power down	11	uA	
	Sleep state	AT+CFUN=0 (USB disconnected)	0.96	mA	
		GSM DRX=2 (USB disconnected)	2.14	mA	
		GSM DRX=9 (USB disconnected)	1.49	mA	
		WCDMA PF=64 (USB disconnected)	1.99	mA	
		WCDMA PF=128 (USB disconnected)	1.39	mA	
		LTE-FDD PF=64 (USB disconnected)	2.48	mA	
		LTE-FDD PF=128 (USB disconnected)	1.81	mA	
		LTE-TDD PF=64 (USB disconnected)	2.79	mA	
		LTE-TDD PF=128 (USB disconnected)	2.00	mA	
		GSM DRX=5 (USB disconnected)	19.5	mA	
		GSM DRX=5 (USB connected)	29.5	mA	
		WCDMA PF=64 (USB disconnected)	21.0	mA	
		WCDMA PF=64 (USB connected)	31.0	mA	
		Idle state	LTE-FDD PF=64 (USB disconnected)	20.7	mA
			LTE-FDD PF=64 (USB connected)	30.8	mA
	LTE-TDD PF=64 (USB disconnected)		20.8	mA	
	LTE-TDD PF=64 (USB connected)		32.0	mA	
	GPRS data transfer (GNSS OFF)		EGSM900 4DL/1UL @33.23dBm	265.0	mA
		EGSM900 3DL/2UL @31.96dBm	388.0	mA	
EGSM900 2DL/3UL @29.73dBm		461.0	mA		
EGSM900 1DL/4UL @28.5dBm		593.0	mA		
DCS1800 4DL/1UL @30.49dBm		156.0	mA		

	DCS1800 3DL/2UL @29.24dBm	245.0	mA
	DCS1800 2DL/3UL @27.15dBm	337.0	mA
	DCS1800 1DL/4UL @25.88dBm	427.0	mA
	EGSM900 4DL/1UL PCL=8 @26.60dBm	170.0	mA
	EGSM900 3DL/2UL PCL=8 @25.43dBm	205.0	mA
	EGSM900 2DL/3UL PCL=8 @23.4dBm	280.0	mA
EDGE data transfer (GNSS OFF)	EGSM900 1DL/4UL PCL=8 @22.36dBm	348.0	mA
	DCS1800 4DL/1UL PCL=2 @25.59dBm	136.0	mA
	DCS1800 3DL/2UL PCL=2 @24.54dBm	225.0	mA
	DCS1800 2DL/3UL PCL=2 @22.38dBm	300.0	mA
	DCS1800 1DL/4UL PCL=2 @21.24dBm	379.0	mA
WCDMA data transfer (GNSS OFF)	WCDMA B1 HSDPA @22.93dBm	504.0	mA
	WCDMA B1 HSUPA @22.62dBm	512.0	mA
	WCDMA B8 HSDPA @22.88dBm	562.0	mA
	WCDMA B8 HSUPA @22.14dBm	535.0	mA
LTE data transfer (GNSS OFF)	LTE-FDD B1 @23.6dBm	664.0	mA
	LTE-FDD B3 @23.67dBm	693.0	mA
	LTE-FDD B7 @23.83dBm	800.0	mA
	LTE-FDD B8 @23.82dBm	695.0	mA
	LTE-FDD B20 @23.88dBm	690.0	mA
	LTE-FDD B28A @23.43dBm	669.0	mA
	LTE-TDD B38 @22.82dBm	438.0	mA
	LTE-TDD B40 @23.43dBm	355.0	mA
	LTE-TDD B41 @23.46dBm	451.0	mA
GSM	EGSM900 PCL=5 @33.25dBm	258.0	mA

voice call	DCS1800 PCL=0 @30.23dBm	178.0	mA
WCDMA voice call	WCDMA B1 @23.88dBm	533.0	mA
	WCDMA B8 @23.8dBm	506.0	mA

Table 43: Current Consumption of EC25-AFX Mini PCIe

Parameter	Description	Conditions	Typ.	Unit	
I _V BAT		AT+CFUN=0 (USB disconnected)	1.67	mA	
		WCDMA PF=64 (USB disconnected)	2.51	mA	
		WCDMA PF=64 (USB connected)	2.93	mA	
		WCDMA PF=128 (USB disconnected)	2.16	mA	
		WCDMA PF=256 (USB disconnected)	2.07	mA	
		Sleep state	WCDMA PF=512 (USB disconnected)	1.88	mA
		LTE-FDD PF=32 (USB disconnected)	4.29	mA	
		LTE-FDD PF=64 (USB disconnected)	3.04	mA	
		LTE-FDD PF=64 (USB connected)	3.23	mA	
		LTE-FDD PF=128 (USB disconnected)	2.39	mA	
		LTE-FDD PF=256 (USB disconnected)	2.06	mA	
		Idle state	WCDMA PF=64 (USB disconnected)	22.0	mA
			WCDMA PF=64 (USB connected)	43.0	mA
			LTE-FDD PF=64 (USB disconnected)	22.0	mA
			LTE-FDD PF=64 (USB connected)	42.8	mA
		WCDMA data transfer (GNSS OFF)	WCDMA B2 HSDPA @22.45dBm	691.0	mA
WCDMA B2 HSUPA @22.23dBm	605.0		mA		
WCDMA B4 HSDPA @22.42dBm	628.0		mA		
WCDMA B4 HSUPA @22.11dBm	630.0		mA		

	WCDMA B5 HSDPA @22.02dBm	618.0	mA
	WCDMA B5 HSUPA @22.10dBm	634.0	mA
	LTE-FDD B2 @23.01dBm	743.0	mA
	LTE-FDD B4 @22.58dBm	816.0	mA
	LTE-FDD B5 @23.2dBm	751.0	mA
LTE data transfer (GNSS OFF)	LTE-FDD B12 @22.94dBm	825.0	mA
	LTE-FDD B13 @23.18dBm	815.0	mA
	LTE-FDD B14 @23.44dBm	849.0	mA
	LTE-FDD B66 @23.2dBm	850.0	mA
	LTE-FDD B71 @22.82dBm	788.0	mA
WCDMA voice call	WCDMA B2 @23.27dBm	672.0	mA
	WCDMA B4 @23.22dBm	663.0	mA
	WCDMA B5 @23.02dBm	680.0	mA

Table 44: Current Consumption of EC25-MX Mini PCIe

Parameter	Description	Conditions	Typ.	Unit
I _V BAT	Sleep state	AT+CFUN=0 (USB disconnected)	1.55	mA
		WCDMA PF=64 (USB disconnected)	2.82	mA
		WCDMA PF=64 (USB connected)	2.98	mA
		WCDMA PF=128 (USB disconnected)	2.33	mA
		WCDMA PF=256 (USB disconnected)	2.13	mA
		WCDMA PF=512 (USB disconnected)	1.97	mA
		LTE-FDD PF=32 (USB disconnected)	4.36	mA
		LTE-FDD PF=64 (USB disconnected)	3.14	mA
		LTE-FDD PF=64 (USB connected)	3.33	mA

	LTE-FDD PF=128 (USB disconnected)	2.55	mA
	LTE-FDD PF=256 (USB disconnected)	2.38	mA
Idle state	WCDMA PF=64 (USB disconnected)	20.0	mA
	WCDMA PF=64 (USB connected)	41.1	mA
	LTE-FDD PF=64 (USB disconnected)	20.5	mA
	LTE-FDD PF=64 (USB connected)	40.7	mA
WCDMA data transfer (GNSS OFF)	WCDMA B2 HSDPA @22.75dBm	848.0	mA
	WCDMA B2 HSUPA @22.3dBm	818.0	mA
	WCDMA B4 HSDPA @23.34dBm	813.0	mA
	WCDMA B4 HSUPA @23.11dBm	774.0	mA
	WCDMA B5 HSDPA @22.53dBm	759.0	mA
	WCDMA B5 HSUPA @22.58dBm	717.0	mA
LTE data transfer (GNSS OFF)	LTE-FDD B2 @23.09dBm	918.0	mA
	LTE-FDD B4 @23.12dBm	933.0	mA
	LTE-FDD B5 @22.28dBm	706.0	mA
	LTE-FDD B7 @22.56dBm	1011.0	mA
	LTE-FDD B28 @22.41dBm	793.0	mA
	LTE-FDD B66 @23.94dBm	937.0	mA
WCDMA voice call	WCDMA B2 @23.97dBm	967.0	mA
	WCDMA B4 @23.92dBm	825.0	mA
	WCDMA B5 @23.00dBm	844.0	mA

Table 45: Current Consumption of EC25-AUX Mini PCIe

Parameter	Description	Conditions	Typ.	Unit		
	Sleep state	AT+CFUN=0 (USB disconnected)	1.9	mA		
		GSM DRX=2 (USB disconnected)	2.9	mA		
		GSM DRX=9 (USB disconnected)	2.4	mA		
		WCDMA PF=64 (USB disconnected)	3.8	mA		
		WCDMA PF=128 (USB disconnected)	3.4	mA		
		LTE-FDD PF=64 (USB disconnected)	4.5	mA		
		LTE-FDD PF=128 (USB disconnected)	3.9	mA		
		LTE-TDD PF=64 (USB disconnected)	4.5	mA		
		LTE-TDD PF=128 (USB disconnected)	3.7	mA		
		I _{VBAT}	Idle state	GSM DRX=5 (USB disconnected)	23.4	mA
GSM DRX=5 (USB connected)	43.4			mA		
WCDMA PF=64 (USB disconnected)	24.2			mA		
WCDMA PF=64 (USB connected)	45.6			mA		
LTE-FDD PF=64 (USB disconnected)	28.7			mA		
LTE-FDD PF=64 (USB connected)	43.7			mA		
LTE-TDD PF=64 (USB disconnected)	30.4			mA		
LTE-TDD PF=64 (USB connected)	43.9			mA		
GPRS data transfer (GNSS OFF)				GSM850 4DL/1UL @32.88dBm	368.0	mA
				GSM850 3DL/2UL @31.99dBm	565.5	mA
		GSM850 2DL/3UL @29.94dBm	636.7	mA		
		GSM850 1DL/4UL @28.73dBm	733.7	mA		
		EGSM900 4DL/1UL @33.75dBm	419.3	mA		
		EGSM900 3DL/2UL @32.18dBm	591.5	mA		

	EGSM900 2DL/3UL @29.90dBm	631.4	mA
	EGSM900 1DL/4UL @28.70dBm	725.3	mA
	DCS1800 4DL/1UL @30.02dBm	221.8	mA
	DCS1800 3DL/2UL @29.12dBm	319.6	mA
	DCS1800 2DL/3UL @26.98dBm	384.8	mA
	DCS1800 1DL/4UL @25.80dBm	468.3	mA
	PCS1900 4DL/1UL @30.22dBm	243.2	mA
	PCS1900 3DL/2UL @28.93dBm	336.9	mA
	PCS1900 2DL/3UL @27.00dBm	398.3	mA
	PCS1900 1DL/4UL @25.86dBm	478.0	mA
	GSM850 4DL/1UL @27.45dBm	253.6	mA
	GSM850 3DL/2UL @26.29dBm	389.8	mA
	GSM850 2DL/3UL @23.96dBm	515.4	mA
	GSM850 1DL/4UL @22.72dBm	647.6	mA
	EGSM900 4DL/1UL @27.63dBm	257.2	mA
	EGSM900 3DL/2UL @26.45dBm	399.1	mA
	EGSM900 2DL/3UL @24.27dBm	515.3	mA
	EGSM900 1DL/4UL @22.99dBm	642.0	mA
EDGE data transfer (GNSS OFF)	DCS1800 4DL/1UL @26.55dBm	196.7	mA
	DCS1800 3DL/2UL @25.90dBm	304.4	mA
	DCS1800 2DL/3UL @23.91dBm	408.8	mA
	DCS1800 1DL/4UL @22.61dBm	524.3	mA
	PCS1900 4DL/1UL @26.67dBm	194.7	mA
	PCS1900 3DL/2UL @25.88dBm	299.1	mA
	PCS1900 2DL/3UL @23.85dBm	399.7	mA

	PCS1900 1DL/4UL @22.73dBm	510.1	mA
	WCDMA B1 HSDPA @21.54dBm	679.4	mA
	WCDMA B1 HSUPA @21.82dBm	721.1	mA
	WCDMA B2 HSDPA @22.10dBm	723.0	mA
WCDMA data transfer (GNSS OFF)	WCDMA B2 HSUPA @21.84dBm	708.6	mA
	WCDMA B5 HSDPA @23.27dBm	672.6	mA
	WCDMA B5 HSUPA @22.93dBm	672.0	mA
	WCDMA B8 HSDPA @21.70dBm	667.9	mA
	WCDMA B8 HSUPA @21.12dBm	674.5	mA
	LTE-FDD B1 @23.50dBm	963.9	mA
	LTE-FDD B2 @22.95dBm	941.7	mA
	LTE-FDD B3 @23.27dBm	856.4	mA
LTE data transfer (GNSS OFF)	LTE-FDD B4 @23.28dBm	817.1	mA
	LTE-FDD B5 @23.09dBm	724.5	mA
	LTE-FDD B7 @23.09dBm	945.2	mA
	LTE-FDD B8 @23.64dBm	888.3	mA
	LTE-FDD B28 @22.79dBm	964.5	mA
	LTE-TDD B40 @23.70dBm	428.9	mA
	GSM850 PCL5 @32.75dBm	346.9	mA
GSM voice call	EGSM900 PCL5 @33.53dBm	385.3	mA
	DCS1800 PCL0 @30.03dBm	210.2	mA
	PCS1900 PCL0 @29.94dBm	219.6	mA
WCDMA voice call	WCDMA B1 @23.75dBm	785.1	mA
	WCDMA B2 @23.07dBm	804.5	mA
	WCDMA B5 @23.31dBm	701.8	mA

WCDMA B8 @22.65dBm 739.7 mA

Table 46: Current Consumption of EC25-EU Mini PCIe

Parameter	Description	Conditions	Typ.	Unit
I _{VBAT}	Sleep state	AT+CFUN=0 (USB disconnected)	3.4	mA
		GSM DRX=2 (USB disconnected)	5.2	mA
		GSM DRX=9 (USB disconnected)	4.1	mA
		WCDMA PF=64 (USB disconnected)	4.9	mA
		WCDMA PF=128 (USB disconnected)	4.4	mA
		LTE-FDD PF=64 (USB disconnected)	5.3	mA
		LTE-FDD PF=128 (USB disconnected)	4.6	mA
		LTE-TDD PF=64 (USB disconnected)	5.3	mA
		LTE-TDD PF=128 (USB disconnected)	4.5	mA
	Idle state	GSM DRX=5 (USB disconnected)	23.3	mA
		GSM DRX=5 (USB connected)	35.4	mA
		WCDMA PF=64 (USB disconnected)	23.9	mA
		WCDMA PF=64 (USB connected)	36.3	mA
		LTE-FDD PF=64 (USB disconnected)	24.1	mA
		LTE-FDD PF=64 (USB connected)	36.4	mA
		LTE-TDD PF=64 (USB disconnected)	24.1	mA
LTE-TDD PF=64 (USB connected)		36.3	mA	
GPRS data transfer (GNSS OFF)	EGSM900 4DL/1UL @32.54dBm	379.0	mA	
	EGSM900 3DL/2UL @31.96dBm	610.0	mA	
	EGSM900 2DL/3UL @29.59dBm	654.0	mA	
	EGSM900 1DL/4UL @28.34dBm	734.0	mA	

	DCS1800 4DL/1UL @29.63dBm	236.0	mA
	DCS1800 3DL/2UL @28.59dBm	343.0	mA
	DCS1800 2DL/3UL @26.62dBm	413.0	mA
	DCS1800 1DL/4UL @25.29dBm	498.0	mA
	EGSM900 4DL/1UL @27.51dBm	234.0	mA
	EGSM900 3DL/2UL @27.23dBm	372.0	mA
	EGSM900 2DL/3UL @27.08dBm	501.0	mA
EDGE data transfer (GNSS OFF)	EGSM900 1DL/4UL @26.81dBm	628.0	mA
	DCS1800 4DL/1UL @26.29dBm	199.0	mA
	DCS1800 3DL/2UL @26.18dBm	309.0	mA
	DCS1800 2DL/3UL @26.05dBm	415.0	mA
	DCS1800 1DL/4UL @25.35dBm	503.0	mA
WCDMA data transfer (GNSS OFF)	WCDMA B1 HSDPA @22.01dBm	755.0	mA
	WCDMA B1 HSUPA @22.79dBm	776.0	mA
	WCDMA B8 HSDPA @22.21dBm	670.6	mA
	WCDMA B8 HSUPA @22.04dBm	692.6	mA
LTE data transfer (GNSS OFF)	LTE-FDD B1 @23.63dBm	918.7	mA
	LTE-FDD B3 @22.78dBm	914.0	mA
	LTE-FDD B7 @22.31dBm	985.2	mA
	LTE-FDD B8 @23.35dBm	886.5	mA
	LTE-FDD B20 @22.71dBm	909.1	mA
	LTE-FDD B28A @21.79dBm	898.1	mA
	LTE-TDD B38 @22.85dBm	587.8	mA
	LTE-TDD B40 @22.96dBm	460.6	mA
	LTE-TDD B41 @22.69dBm	571.2	mA

GSM voice call	EGSM900 PCL=5 @32.80dBm	370.0	mA
	DCS1800 PCL=0 @29.51dBm	221.0	mA
WCDMA voice call	WCDMA B1 @22.96dBm	829.5	mA
	WCDMA B8 @23.21dBm	752.9	mA

Table 47: GNSS Current Consumption of EC25 Mini PCIe Series Module

Parameter	Description	Conditions	Typ.	Unit
I _{VBAT} (GNSS)	Searching (AT+CFUN=0)	Cold start @Passive Antenna	75.0	mA
		Lost state @Passive Antenna	74.0	mA
	Tracking (AT+CFUN=0)	Instrument environment	44.0	mA
		Open Sky @Passive Antenna	53.0	mA
		Open Sky @Active Antenna	58.0	mA

6.7. Thermal Consideration

In order to achieve better performance of the module, it is recommended to comply with the following principles for thermal consideration:

- On customers' PCB design, please keep placement of the PCI Express Mini Card away from heating sources.
- Do not place components on the PCB area where the module is mounted, in order to facilitate adding of heatsink.
- Do not apply solder mask on the PCB area where the module is mounted, so as to ensure better heat dissipation performance.
- The reference ground of the area where the module is mounted should be complete, and add ground vias as many as possible for better heat dissipation.
- Add a heatsink on the top of the module and the heatsink should be designed with as many fins as possible to increase heat dissipation area. Meanwhile, a thermal pad with high thermal conductivity should be used between the heatsink and module.
- Add a thermal pad with appropriate thickness at the bottom of the module to conduct the heat to PCB.

The following figure shows the referenced heatsink design.

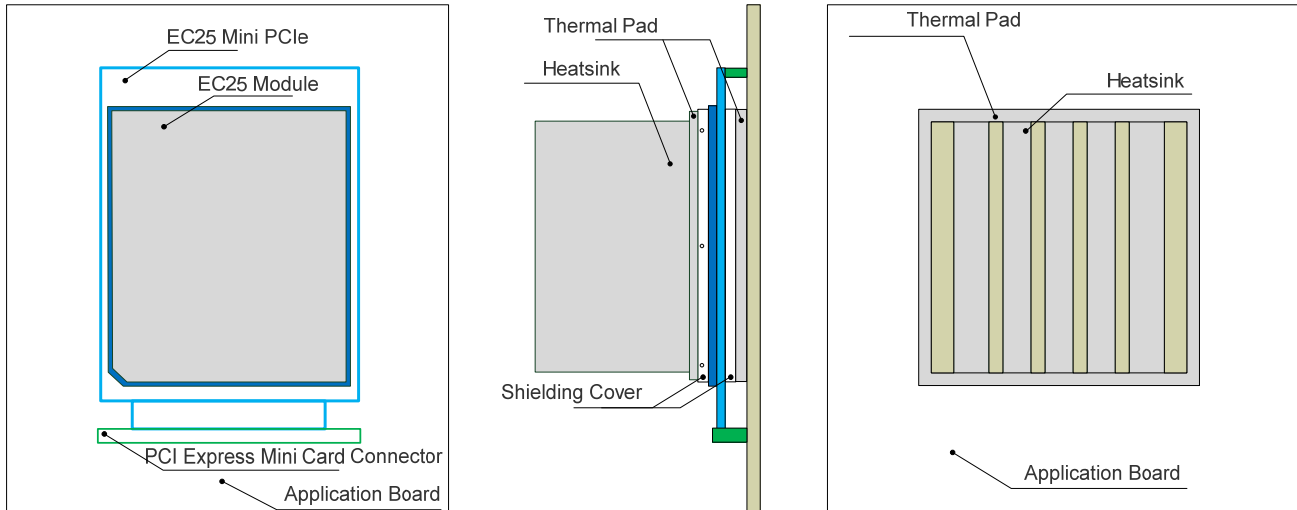

Figure 17: Referenced Heatsink Design

NOTES

1. The module offers the best performance when the internal BB chip stays below 105°C. When the maximum temperature of the BB chip reaches or exceeds 105°C, the module works normal but provides reduced performance (such as RF output power, data rate, etc.). When the maximum BB chip temperature reaches or exceeds 115°C, the module will disconnect from the network, and it will recover to network connected state after the maximum temperature falls below 115°C. Therefore, the thermal design should be maximally optimized to make sure the maximum BB chip temperature always maintains below 105°C. Customers can execute **AT+QTEMP** command and get the maximum BB chip temperature from the first returned value.
2. For more detailed guidelines on thermal design, please refer to **document [4]**.

7 Dimensions and Packaging

7.1. General Description

This chapter mainly describes mechanical dimensions as well as packaging specification of EC25 Mini PCIe module. All dimensions are measured in mm, and the dimensional tolerances are $\pm 0.05\text{mm}$ unless otherwise specified.

7.2. Mechanical Dimensions of EC25 Mini PCIe

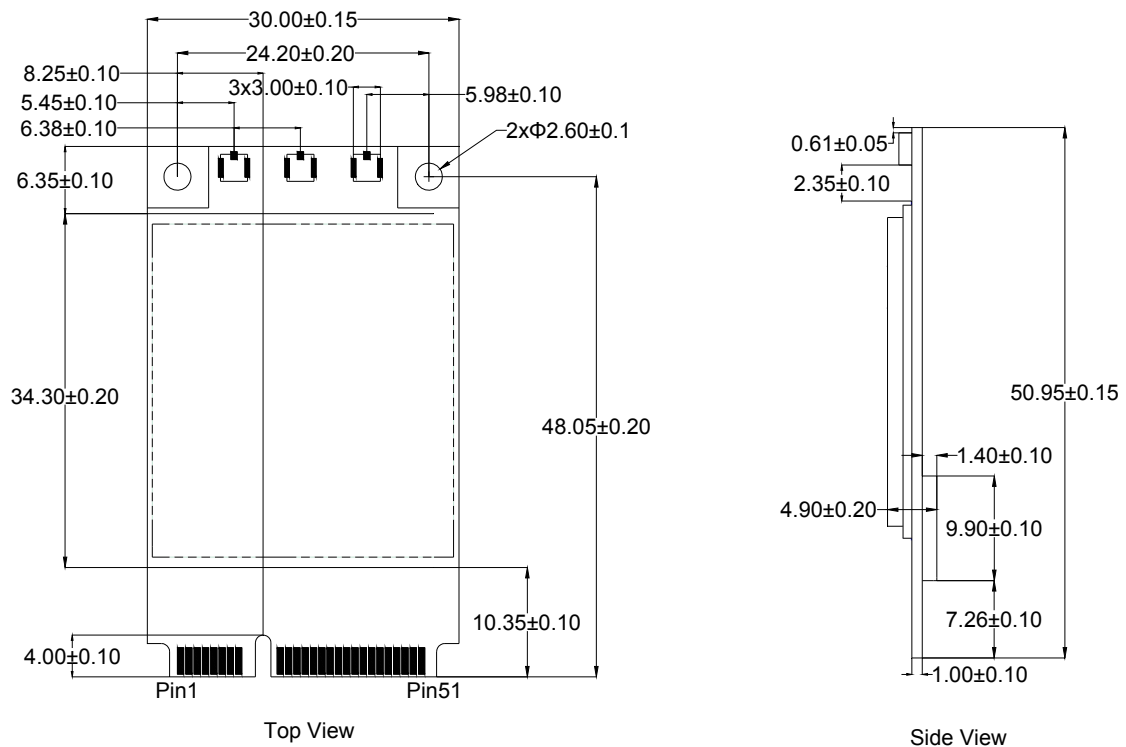

Figure 18: Mechanical Dimensions of EC25 Mini PCIe

EC25 Mini PCIe adopts a standard Mini PCI Express connector which complies with the directives and standards listed in the **document [1]**. The following figure takes the Molex 679100002 as an example.

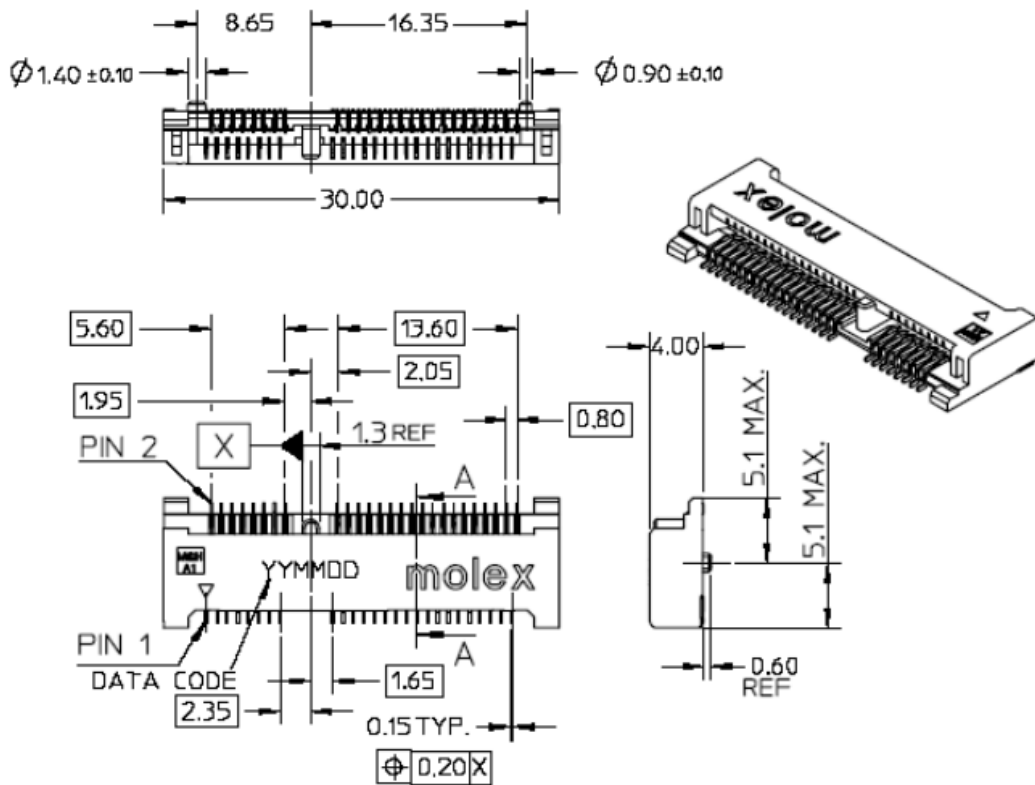

Figure 20: Dimensions of the Mini PCIe Express Connector (Molex 679100002)

7.4. Packaging Specifications

The EC25 Mini PCIe is packaged in a tray. Each tray contains 10pcs of modules. The smallest package of EC25 Mini PCIe contains 100pcs.

8 Appendix A References

Table 48: Related Documents

SN	Document Name	Remark
[1]	PCI Express Mini Card Electromechanical Specification Revision 1.2	Mini PCI Express specification
[2]	Quectel_EC2x&EG9x&EM05_AT_Commands_Manual	AT commands manual for EC25, EC21, EC20 R2.0, EC20 R2.1, EG91, EG95 and EM05 modules
[3]	Quectel_EC2x&EGxx&EM05_GNSS_AT_Commands_Manual	GNSS AT Commands Manual for EC25, EC21, EC20 R2.0, EC20 R2.1, EG95, EG91, EG25-G and EM05 modules
[4]	Quectel_LTE_Module_Thermal_Design_Guide	Thermal design guide for LTE standard, LTE-A and Automotive modules

Table 49: Terms and Abbreviations

Abbreviation	Description
AMR	Adaptive Multi-rate
bps	Bits Per Second
BT	Bluetooth
CS	Coding Scheme
CTS	Clear to Send
DC-HSPA+	Dual-carrier High Speed Packet Access
DFOTA	Delta Firmware Upgrade Over-The-Air
DL	Down Link
DTE	Data Terminal Equipment

DTR	Data Terminal Ready
EFR	Enhanced Full Rate
EMI	Electro Magnetic Interference
ESD	Electrostatic Discharge
ESR	Equivalent Series Resistance
FDD	Frequency Division Duplexing
FR	Full Rate
GLONASS	GLOBALnaya Navigatsionnaya Sputnikovaya Sistema, the Russian Global Navigation Satellite System
GMSK	Gaussian Minimum Shift Keying
GNSS	Global Navigation Satellite System
GPS	Global Positioning System
GSM	Global System for Mobile Communications
HR	Half Rate
HSPA	High Speed Packet Access
HSUPA	High Speed Uplink Packet Access
kbps	Kilo Bits Per Second
LED	Light Emitting Diode
LTE	Long-Term Evolution
Mbps	Million Bits Per Second
MCU	Micro Control Unit
ME	Mobile Equipment
MIMO	Multiple-Input Multiple-Output
MMS	Multimedia Messaging Service
MO	Mobile Originated
MT	Mobile Terminated

NMEA	National Marine Electronics Association
PCM	Pulse Code Modulation
PDA	Personal Digital Assistant
PDU	Protocol Data Unit
POS	Point of Sale
PPP	Point-to-Point Protocol
RF	Radio Frequency
RTS	Ready To Send
Rx	Receive
SIMO	Single Input Multiple Output
SMS	Short Message Service
TX	Transmitting Direction
TVS	Transient Voltage Suppressor
UART	Universal Asynchronous Receiver & Transmitter
UL	Up Link
URC	Unsolicited Result Code
USB	Universal Serial Bus
(U)SIM	(Universal) Subscriber Identification Module
WCDMA	Wideband Code Division Multiple Access
WLAN	Wireless Local Area Networks
