

# FCC Radio Test Report

## FCC ID: XMR2019SC650TNA

This report concerns: Original Grant

**Project No.** : 2001H013  
**Equipment** : Smart Module  
**Brand Name** : QUECTEL  
**Test Model** : SC650T-NA  
**Series Model** : N/A  
**Applicant** : Quectel Wireless Solutions Co., Ltd.  
**Address** : Building 5, Shanghai Business Park Phase III (Area B), No.1016 Tianlin Road, Minhang District, Shanghai, China 200233.  
**Manufacturer** : Quectel Wireless Solutions Co., Ltd.  
**Address** : Building 5, Shanghai Business Park Phase III (Area B), No.1016 Tianlin Road, Minhang District, Shanghai, China 200233.  
**Date of Receipt** : Jan. 15, 2020  
**Date of Test** : Jan. 15, 2020~Feb. 27, 2020  
**Issued Date** : Mar. 19, 2020  
**Report Version** : R01  
**Test Sample** : Engineering Sample No.: SH2020011452  
**Standard(s)** : 47 CFR FCC Part 24 Subpart E  
47 CFR FCC Part 2  
ANSI/TIA/EIA-603-E-2016  
FCC KDB 971168 D01 Power Meas License Digital Systems v03r01

The above equipment has been tested and found compliance with the requirement of the relative standards by BTL Inc.

*Iscaa Min*

Prepared by : Iscaa Min

*Krain. Wu*

Approved by : Krain Wu



Certificate # 5123.03

Add: No. 29, Jintang Road, Tangzhen Industry Park, Pudong New Area, Shanghai 201210, China

TEL: +86-021-61765666

Web: www.newbtl.com

**Declaration**

**BTL** represents to the client that testing is done in accordance with standard procedures as applicable and that test instruments used has been calibrated with standards traceable to international standard(s) and/or national standard(s).

**BTL's** reports apply only to the specific samples tested under conditions. It is manufacture's responsibility to ensure that additional production units of this model are manufactured with the identical electrical and mechanical components. **BTL** shall have no liability for any declarations, inferences or generalizations drawn by the client or others from **BTL** issued reports.

The report must not be used by the client to claim product certification, approval, or endorsement by NIST, A2LA, or any agency of the U.S. Government.

This report is the confidential property of the client. As a mutual protection to the clients, the public and ourselves, the test report shall not be reproduced, except in full, without our written approval.

**BTL's** laboratory quality assurance procedures are in compliance with the **ISO/IEC 17025** requirements, and accredited by the conformity assessment authorities listed in this test report.

**BTL** is not responsible for the sampling stage, so the results only apply to the sample as received.

The information, data and test plan are provided by manufacturer which may affect the validity of results, so it is manufacturer's responsibility to ensure that the apparatus meets the essential requirements of applied standards and in all the possible configurations as representative of its intended use.

**Limitation**

For the use of the authority's logo is limited unless the Test Standard(s)/Scope(s)/Item(s) mentioned in this test report is (are) included in the conformity assessment authorities acceptance respective.

Please note that the measurement uncertainty is provided for informational purpose only and is not use in determining the Pass/Fail results.

<b>Table of Contents</b>	<b>Page</b>
<b>REPORT ISSUED HISTORY</b>	<b>5</b>
<b>1 . SUMMARY OF TEST RESULTS</b>	<b>6</b>
1.1 TEST FACILITY	7
1.2 MEASUREMENT UNCERTAINTY	7
1.3 TEST ENVIRONMENT CONDITIONS	7
<b>2 . GENERAL INFORMATION</b>	<b>8</b>
2.1 GENERAL DESCRIPTION OF EUT	8
2.2 DESCRIPTION OF TEST MODES AND TEST CONDITION	10
2.3 BLOCK DIAGRAM SHOWING THE CONFIGURATION OF SYSTEM TESTED	14
3.4 DESCRIPTION OF SUPPORT UNITS	14
<b>3 . TEST RESULT</b>	<b>15</b>
3.1 OUTPUT POWER MEASUREMENT	15
3.1.1 LIMIT	15
3.1.2 TEST PROCEDURE	15
3.1.3 TEST SETUP LAYOUT	15
3.1.4 TEST DEVIATION	15
3.1.5 TEST RESULTS	15
3.2 OCCUPIED BANDWIDTH MEASUREMENT	16
3.2.1 TEST PROCEDURE	16
3.2.2 TEST SETUP LAYOUT	16
3.2.3 TEST DEVIATION	16
3.2.4 TEST RESULTS	16
3.3 CONDUCTED EMISSIONS MEASUREMENT	17
3.3.1 LIMIT	17
3.3.2 TEST PROCEDURES	17
3.3.3 TEST SETUP LAYOUT	17
3.3.4 TEST DEVIATION	17
3.3.5 TEST RESULTS	17
3.4 RADIATED EMISSIONS MEASUREMENT	18
3.4.1 LIMIT	18
3.4.2 TEST PROCEDURES	18
3.4.3 TEST SETUP LAYOUT	19
3.4.4 TEST DEVIATION	20
3.4.5 TEST RESULTS (30MHZ TO 1000MHZ)	20
3.4.6 TEST RESULTS (ABOVE 1000MHZ)	20
3.5 BAND EDGE MEASUREMENT	21
3.5.1 LIMIT	21

<b>Table of Contents</b>	<b>Page</b>
3.5.2 TEST PROCEDURES	21
3.5.3 TEST SETUP LAYOUT	21
3.5.4 TEST DEVIATION	21
3.5.5 TEST RESULTS	21
3.6 PEAK TO AVERAGE RATIO MEASUREMENT	22
3.6.1 LIMIT	22
3.6.2 TEST PROCEDURES	22
3.6.3 TEST SETUP LAYOUT	22
3.6.4 TEST DEVIATION	22
3.6.5 TEST RESULTS	22
3.7 FREQUENCY STABILITY MEASUREMENT	23
3.7.1 LIMIT	23
3.7.2 TEST PROCEDURES	23
3.7.3 TEST SETUP LAYOUT	23
3.7.4 TEST DEVIATION	23
3.7.5 TEST RESULTS	23
4. LIST OF MEASUREMENT EQUIPMENTS	24
APPENDIX A - OUTPUT POWER	26
APPENDIX B - OCCUPIED BANDWIDTH	39
APPENDIX C - CONDUCTED EMISSIONS	64
APPENDIX D - RADIATED EMISSION (30MHZ TO 1GHZ)	71
APPENDIX E - RADIATED EMISSION (ABOVE 1GHZ)	76
APPENDIX F - BAND EDGE	89
APPENDIX G - PEAK TO AVERAGE RATIO	102
APPENDIX H - FREQUENCY STABILITY	115

**REPORT ISSUED HISTORY**

Report Version	Description	Issued Date
R00	Original Issue.	Mar. 16, 2020
R01	Modify the type error of channel and frequency of band 25.	Mar. 19, 2020

## 1. SUMMARY OF TEST RESULTS

Test procedures according to the technical standard(s):

FCC Part 24 Subpart E& Part 2			
Standard(s) Section	Test Item	Judgment	Remark
2.1046 & 24.232(c)	Equivalent Isotropic Radiated Power	PASS	-----
2.1049	Occupied Bandwidth	PASS	-----
2.1051 & 24.238(a)	Conducted Spurious Emissions	PASS	-----
2.1053 & 24.238(a)	Radiated Spurious Emissions	PASS	-----
24.238(a)	Band Edge Measurements	PASS	-----
24.232(d)	Peak To Average Ratio	PASS	-----
2.1055 & 24.235	Frequency Stability	PASS	-----

**Note:**

For the verdict, the "N/A" denotes "not applicable", the "N/T" denotes "not tested".

### 1.1 TEST FACILITY

The test facilities used to collect the test data in this report is at the location of No. 29, Jintang Road, Tangzhen Industry Park, Pudong New Area, Shanghai 201210, China.

BTL's Test Firm Registration Number for FCC: 476765

BTL's Designation Number for FCC: CN1241

### 1.2 MEASUREMENT UNCERTAINTY

The measurement uncertainty figures shall be calculated according the methods described in the ETSI TR 100 028 and shall correspond to an expansion factor (coverage factor)  $k=1.96$  or  $k=2$ (which provide confidence levels of respectively 90% and 95.45% in the case where the distributions characterizing the actual measurement uncertainties are normal (Gaussian)).

Measurement Uncertainty for a Level of Confidence of 95 %,  $U=2xUc(y)$ .

The BTL measurement uncertainty as below table:

#### A. Radiated Measurement :

Test Site	Method	Measurement Frequency Range	Ant. H / V	U,(dB)
SH-CB01	CISPR	9KHz ~ 30MHz	V	3.79
		9KHz ~ 30MHz	H	3.57
		30MHz ~ 200MHz	V	4.12
		30MHz ~ 200MHz	H	3.20
		200MHz ~ 1,000MHz	V	3.12
		200MHz ~ 1,000MHz	H	3.18

Test Site	Method	Measurement Frequency Range	U,(dB)
SH-CB01	CISPR	1GHz ~ 6GHz	4.40
		6GHz ~ 18GHz	4.86

Test Site	Method	Measurement Frequency Range	U,(dB)
SH-CB01	CISPR	18 ~ 26.5 GHz	3.64
		26.5 ~ 40 GHz	3.78

Note: Unless specifically mentioned, the uncertainty of measurement has not been taken into account to declare the compliance or non-compliance to the specification.

### 1.3 TEST ENVIRONMENT CONDITIONS

Test Item	Environmental Conditions	Test Voltage
EIRP	23°C, 59%RH	DC 3.8V
Output Power	23°C, 59%RH	DC 3.8V
Occupied Bandwidth	23°C, 59%RH	DC 3.8V
Conducted Emission	23°C, 59%RH	DC 3.8V
Radiated Emission	18°C, 40%RH	DC 3.8V
Band Edge	23°C, 59%RH	DC 3.8V
Peak to Average Ratio	23°C, 59%RH	DC 3.8V
Frequency Stability	Normal and Extreme	Normal and Extreme

## 2. GENERAL INFORMATION

### 2.1 GENERAL DESCRIPTION OF EUT

Equipment	Smart Module	
Brand Name	QUECTEL	
Test Model	SC650T-NA	
Series Model	N/A	
Model Difference(s)	N/A	
Software Version	SC650TNAPAR05A03	
Hardware Version	R1.0	
Power Source	DC power supply.	
Power Rating	DC 3.8V	
IMEI No.1	861394040018223	
IMEI No.2	861394040018231	
Antenna Type	Internal Antenna	
Antenna Gain	LTE Band 2	1.59dBi
	LTE Band 25	
Modulation Type	LTE	UL: QPSK,16QAM DL: QPSK,16QAM
Operation Frequency	LTE Band 2 (Channel Bandwidth: 1.4MHz)	1850.7MHz ~ 1909.3MHz
	LTE Band 2 (Channel Bandwidth: 3MHz)	1851.5MHz ~ 1908.5MHz
	LTE Band 2 (Channel Bandwidth: 5MHz)	1852.5MHz ~ 1907.5MHz
	LTE Band 2 (Channel Bandwidth: 10MHz)	1855.0MHz ~ 1905.0MHz
	LTE Band 2 (Channel Bandwidth: 15MHz)	1857.5MHz ~ 1902.5MHz
	LTE Band 2 (Channel Bandwidth: 20MHz)	1860.0MHz ~ 1900.0MHz
	LTE Band 25 (Channel Bandwidth: 1.4MHz)	1850.7MHz ~ 1914.3MHz
	LTE Band 25 (Channel Bandwidth: 3MHz)	1851.5MHz ~ 1913.5MHz
	LTE Band 25 (Channel Bandwidth: 5MHz)	1852.5MHz ~ 1912.5MHz
	LTE Band 25 (Channel Bandwidth: 10MHz)	1855.0MHz ~ 1910.0MHz
	LTE Band 25 (Channel Bandwidth: 15MHz)	1857.5MHz ~ 1907.5MHz
LTE Band 25 (Channel Bandwidth: 20MHz)	1860.0MHz ~ 1905.0MHz	



Max. EIRP Power	LTE Band 2 (Channel Bandwidth: 1.4MHz)	QPSK	25.31	dBm
		16QAM	24.08	dBm
	LTE Band 2 (Channel Bandwidth: 3MHz)	QPSK	25.04	dBm
		16QAM	24.12	dBm
	LTE Band 2 (Channel Bandwidth: 5MHz)	QPSK	25.12	dBm
		16QAM	23.63	dBm
	LTE Band 2 (Channel Bandwidth: 10MHz)	QPSK	25.31	dBm
		16QAM	23.96	dBm
	LTE Band 2 (Channel Bandwidth: 15MHz)	QPSK	25.05	dBm
		16QAM	23.67	dBm
	LTE Band 2 (Channel Bandwidth: 20MHz)	QPSK	24.67	dBm
		16QAM	23.55	dBm
	LTE Band 25 (Channel Bandwidth: 1.4MHz)	QPSK	25.01	dBm
		16QAM	24.04	dBm
	LTE Band 25 (Channel Bandwidth: 3MHz)	QPSK	24.85	dBm
		16QAM	23.81	dBm
	LTE Band 25 (Channel Bandwidth: 5MHz)	QPSK	24.99	dBm
		16QAM	23.54	dBm
	LTE Band 25 (Channel Bandwidth: 10MHz)	QPSK	25.20	dBm
		16QAM	23.97	dBm
LTE Band 25 (Channel Bandwidth: 15MHz)	QPSK	25.47	dBm	
	16QAM	24.21	dBm	
LTE Band 25 (Channel Bandwidth: 20MHz)	QPSK	24.56	dBm	
	16QAM	23.53	dBm	

**Note:**

1. For a more detailed features description, please refer to the manufacturer's specifications or the user's manual.

## 2.2 DESCRIPTION OF TEST MODES AND TEST CONDITION

Following channel(s) was (were) selected for the final test as listed below:

LTE BAND 2 MODE					
Test Item	Available Channel	Tested Channel	Channel Bandwidth	Modulation	Mode
Output Power & EIRP	18607 to 19193	18607, 18900, 19193	1.4MHz	QPSK, 16QAM	1RB/3RB/6RB
	18615 to 19185	18615, 18900, 19185	3MHz	QPSK, 16QAM	1RB/8RB/15RB
	18625 to 19175	18625, 18900, 19175	5MHz	QPSK, 16QAM	1RB/12RB/25RB
	18650 to 19150	18650, 18900, 19150	10MHz	QPSK, 16QAM	1RB/25RB/50RB
	18675 to 19125	18675, 18900, 19125	15MHz	QPSK, 16QAM	1RB/36RB/75RB
	18700 to 19100	18700, 18900, 19100	20MHz	QPSK, 16QAM	1RB/50RB/100RB
Occupied Bandwidth	18607 to 19193	18607, 18900, 19193	1.4MHz	QPSK, 16QAM	6RB
	18615 to 19185	18615, 18900, 19185	3MHz	QPSK, 16QAM	15RB
	18625 to 19175	18625, 18900, 19175	5MHz	QPSK, 16QAM	25RB
	18650 to 19150	18650, 18900, 19150	10MHz	QPSK, 16QAM	50RB
	18675 to 19125	18675, 18900, 19125	15MHz	QPSK, 16QAM	75 RB
	18700 to 19100	18700, 18900, 19100	20MHz	QPSK, 16QAM	100RB
Conducted Emission	18607 to 19193	18900	1.4 MHz	QPSK	1RB
	18625 to 19175	18900	5MHz	QPSK	1RB
	18700 to 19100	18900	20MHz	QPSK	1RB
Radiated Emission	18607 to 19193	18900	1.4 MHz	QPSK	1RB
	18625 to 19175	18900	5MHz	QPSK	1RB
	18700 to 19100	18900	20MHz	QPSK	1RB
Band Edge	18607 to 19193	18607	1.4MHz	QPSK	1RB/6RB
		19193	1.4MHz	QPSK	
	18615 to 19185	18615	3MHz	QPSK	1RB/15RB
		19185	3MHz	QPSK	
	18625 to 19175	18625	5MHz	QPSK	1RB/25RB
		19175	5MHz	QPSK	
	18650 to 19150	18650	10MHz	QPSK	1RB/50RB
		19150	10MHz	QPSK	
	18675 to 19125	18675	15MHz	QPSK	1RB/75RB
		19125	15MHz	QPSK	
	18700 to 19100	18700	20MHz	QPSK	1RB/100RB
		19100	20MHz	QPSK	

LTE BAND 2 MODE					
Test Item	Available Channel	Tested Channel	Channel Bandwidth	Modulation	Mode
Peak To Average Ratio	18607 to 19193	18607, 18900, 19193	1.4MHz	QPSK, 16QAM	6RB
	18615 to 19185	18615, 18900, 19185	3MHz	QPSK, 16QAM	15RB
	18625 to 19175	18625, 18900, 19175	5MHz	QPSK, 16QAM	25RB
	18650 to 19150	18650, 18900, 19150	10MHz	QPSK, 16QAM	50RB
	18675 to 19125	18675, 18900, 19125	15MHz	QPSK, 16QAM	75 RB
	18700 to 19100	18700, 18900, 19100	20MHz	QPSK, 16QAM	100RB
Frequency Stability	18607 to 19193	18900	1.4MHz	QPSK	1RB
	18615 to 19185	18900	3MHz	QPSK	1RB
	18625 to 19175	18900	5MHz	QPSK	1RB
	18650 to 19150	18900	10MHz	QPSK	1RB
	18675 to 19125	18900	15MHz	QPSK	1RB
	18700 to 19100	18900	20MHz	QPSK	1RB

LTE BAND 25 MODE					
Test Item	Available Channel	Tested Channel	Channel Bandwidth	Modulation	Mode
Output Power & EIRP	26047 to 26683	26047, 26365, 26683	1.4MHz	QPSK, 16QAM	1RB/3RB/6RB
	26055 to 26675	26055, 26365, 26675	3MHz	QPSK, 16QAM	1RB/8RB/15RB
	26065 to 26665	26065, 26365, 26665	5MHz	QPSK, 16QAM	1RB/12RB/25RB
	26090 to 26640	26090, 26365, 26640	10MHz	QPSK, 16QAM	1RB/25RB/50RB
	26115 to 26615	26115, 26365, 26615	15MHz	QPSK, 16QAM	1RB/36RB/75RB
	26140 to 26590	26140, 26365, 26590	20MHz	QPSK, 16QAM	1RB/50RB/100RB
Occupied Bandwidth	26047 to 26683	26047, 26365, 26683	1.4MHz	QPSK, 16QAM	6RB
	26055 to 26675	26055, 26365, 26675	3MHz	QPSK, 16QAM	15RB
	26065 to 26665	26065, 26365, 26665	5MHz	QPSK, 16QAM	25RB
	26090 to 26640	26090, 26365, 26640	10MHz	QPSK, 16QAM	50RB
	26115 to 26615	26115, 26365, 26615	15MHz	QPSK, 16QAM	75 RB
	26140 to 26590	26140, 26365, 26590	20MHz	QPSK, 16QAM	100RB
Conducted Emission	26047 to 26683	26365	1.4 MHz	QPSK	1RB
	26065 to 26665	26365	5MHz	QPSK	1RB
	26140 to 26590	26365	20MHz	QPSK	1RB
Radiated Emission	26047 to 26683	26365	1.4 MHz	QPSK	1RB
	26065 to 26665	26365	5MHz	QPSK	1RB
	26140 to 26590	26365	20MHz	QPSK	1RB
Band Edge	26047 to 26683	26047	1.4MHz	QPSK	1RB/6RB
		26683	1.4MHz	QPSK	
	26055 to 26675	26055	3MHz	QPSK	1RB/15RB
		26675	3MHz	QPSK	
	26065 to 26665	26065	5MHz	QPSK	1RB/25RB
		26665	5MHz	QPSK	
	26090 to 26640	26090	10MHz	QPSK	1RB/50RB
		26640	10MHz	QPSK	
	26115 to 26615	26115	15MHz	QPSK	1RB/75RB
		26615	15MHz	QPSK	
	26140 to 26590	26140	20MHz	QPSK	1RB/100RB
		26590	20MHz	QPSK	

LTE BAND 25 MODE					
Test Item	Available Channel	Tested Channel	Channel Bandwidth	Modulation	Mode
Peak To Average Ratio	26047 to 26683	26047, 26365, 26683	1.4MHz	QPSK, 16QAM	6RB
	26055 to 26675	26055, 26365, 26675	3MHz	QPSK, 16QAM	15RB
	26065 to 26665	26065, 26365, 26665	5MHz	QPSK, 16QAM	25RB
	26090 to 26640	26090, 26365, 26640	10MHz	QPSK, 16QAM	50RB
	26115 to 26615	26115, 26365, 26615	15MHz	QPSK, 16QAM	75 RB
	26140 to 26590	26140, 26365, 26590	20MHz	QPSK, 16QAM	100RB
Frequency Stability	26047 to 26683	26365	1.4MHz	QPSK	1RB
	26055 to 26675	26365	3MHz	QPSK	1RB
	26065 to 26665	26365	5MHz	QPSK	1RB
	26090 to 26640	26365	10MHz	QPSK	1RB
	26115 to 26615	26365	15MHz	QPSK	1RB
	26140 to 26590	26365	20MHz	QPSK	1RB

**2.3 BLOCKDIGRAMSHOWINGTHECONFIGURATIONOFSYSTEMTESTED**

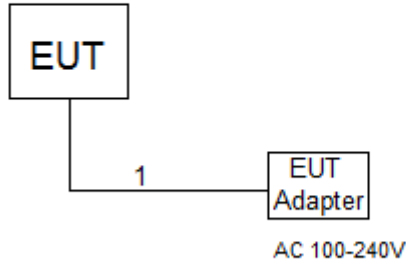

**3.4 DESCRIPTION OF SUPPORT UNITS**

The EUT has been tested as an independent unit together with other necessary accessories or support units. The following support units or accessories were used to form a representative test configuration during the tests.

Item	Equipment	Mfr/Brand	Model/Type No.	Series No.
1	Adapter	-	YHSW-050100U/T	-

Item	Cable Type	Shielded Type	Ferrite Core	Length
1	DC Cable	N/A	N/A	1m

### 3. TEST RESULT

#### 3.1 OUTPUT POWER MEASUREMENT

##### 3.1.1 LIMIT

Mobile / Portable station are limited to 2 watts e.i.r.p.

##### 3.1.2 TEST PROCEDURE

###### EIRP:

$EIRP = \text{Output Power} + \text{Antenan gain}$

###### Output Power:

The EUT was set up for the maximum power with LTE link data modulation and link up with simulator.  
Set the EUT to transmit under low, middle and high channel and record the power level shown on simulator.

##### 3.1.3 TEST SETUP LAYOUT

Output Power Measurement

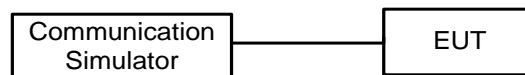

##### 3.1.4 TEST DEVIATION

No deviation

##### 3.1.5 TEST RESULTS

Please refer to the Appendix A.

## 3.2 OCCUPIED BANDWIDTH MEASUREMENT

### 3.2.1 TEST PROCEDURE

The EUT makes a call to the communication simulator. All measurements were done at low, middle and high operational frequency range. The communication simulator station system controlled a EUT to export maximum output power under transmission mode and specific channel frequency. Use OBW measurement function of Spectrum analyzer to measure 99 % occupied bandwidth and 26dB bandwidth.

### 3.2.2 TEST SETUP LAYOUT

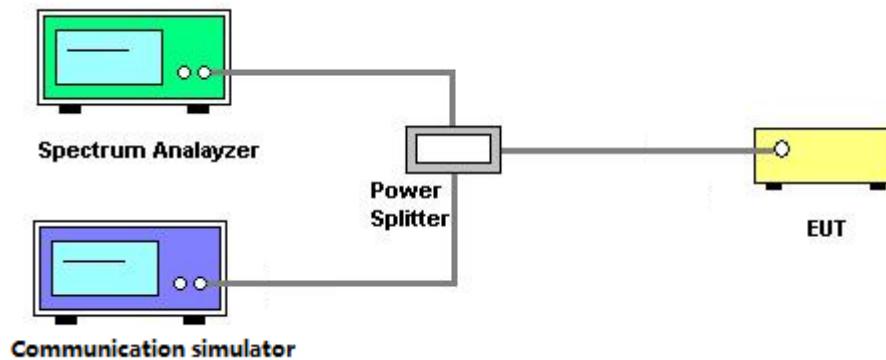

### 3.2.3 TEST DEVIATION

No deviation

### 3.2.4 TEST RESULTS

Please refer to the Appendix B.



### 3.3 CONDUCTED EMISSIONS MEASUREMENT

#### 3.3.1 LIMIT

The power of any emission outside of the authorized operating frequency ranges must be attenuated below the transmitting power (P) by a factor of at least  $43 + 10 \log(P)$  dB. The emission limit equal to -13dBm.

#### 3.3.2 TEST PROCEDURES

1. The testing follows FCC KDB 971168 v03r01 Section 6.0.
2. The EUT was connected to spectrum analyzer and system simulator via a power divider.
3. The band edges of low and high channels for the highest RF powers were measured. Set RBW $\geq$ 1% EBW in the 1MHz band immediately outside and adjacent to the band edge.
4. Set spectrum analyzer with RMS detector.
5. The RF fundamental frequency should be excluded against the limit line in the operating frequency band.

#### 3.3.3 TEST SETUP LAYOUT

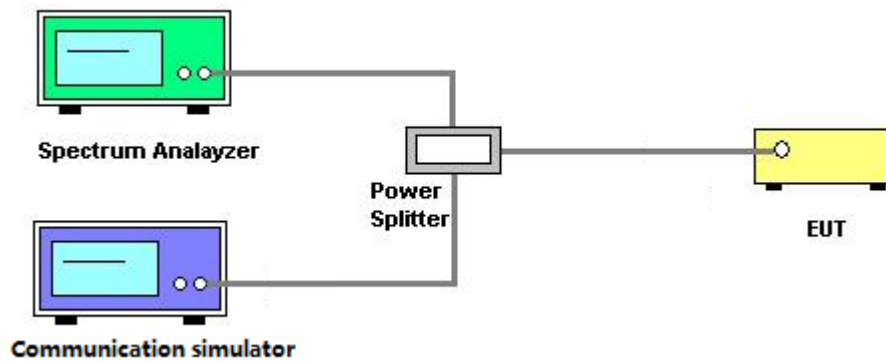

#### 3.3.4 TEST DEVIATION

No deviation

#### 3.3.5 TEST RESULTS

Please refer to the Appendix C.

### **3.4 RADIATED EMISSIONS MEASUREMENT**

#### **3.4.1 LIMIT**

The power of any emission outside of the authorized operating frequency ranges must be attenuated below the transmitting power (P) by a factor of at least  $43 + 10 \log(P)$  dB. The emission limit equal to -13dBm.

#### **3.4.2 TEST PROCEDURES**

1. In the semi-anechoic chamber, EUT placed on the 0.8m height of Turn Table, rotated the table around 360 degrees to search the maximum radiation power and receiver antenna shall be rotated vertical and horizontal polarization and moved height from 1m to 4m to find the maximum polar radiated power. The "Read Value" is the spectrum reading the maximum power value.
2. The substitution horn antenna is substituted for EUT at the same position and signals generator export the CW signal to the substitution antenna via a TX cable. Rotated the Turn Table and moved receiving antenna to find the maximum radiation power. Adjust output power level of S.G to get a Value of spectrum reading equal to "Read Value " of step a. Record the power level of S.G
3.  $EIRP = \text{Output power level of S.G} - \text{TX cable loss} + \text{Antenna gain of substitution horn}$ .
4. E.R.P power can be calculated form E.I.R.P power by subtracting the gain of dipole,  $E.R.P \text{ power} = E.I.P.R \text{ power} - 2.15\text{dBi}$ .
5. The resolution bandwidth and video bandwidth of test receiver/spectrum analyzer is 1MHz/3MHz.

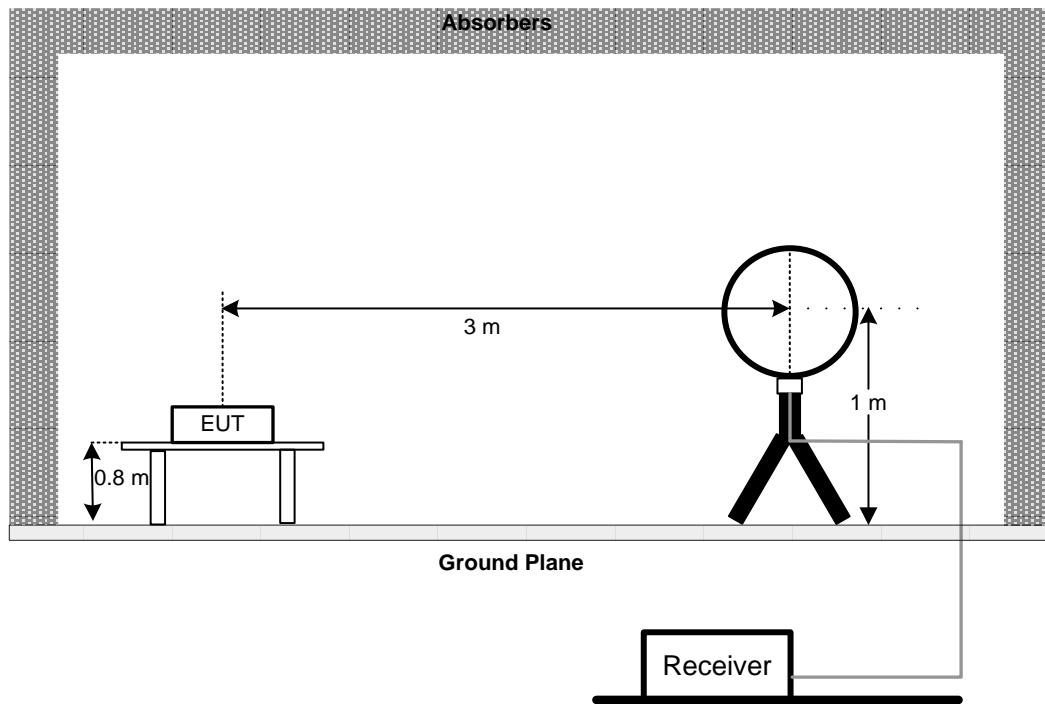
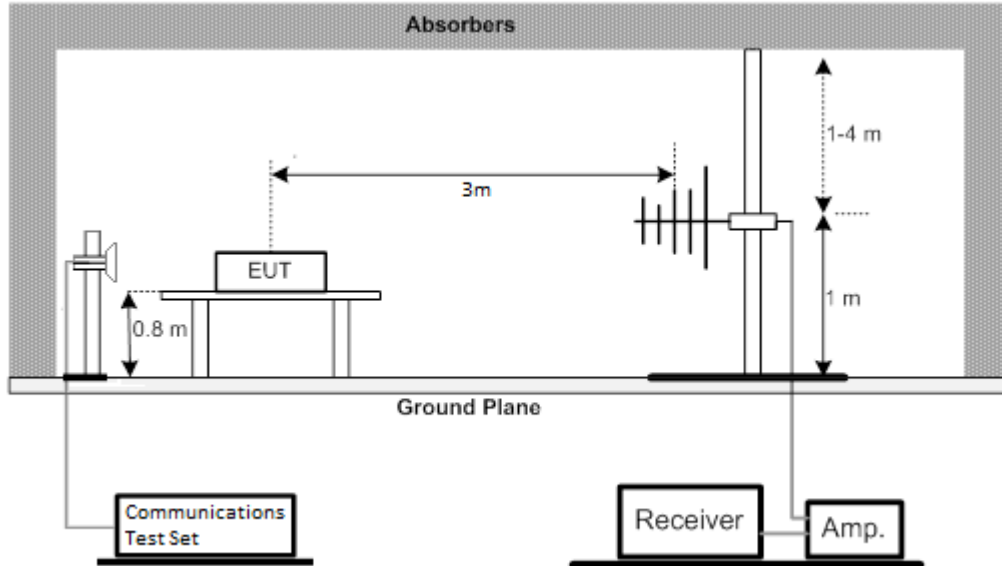
**3.4.3 TEST SETUP LAYOUT****Below 30MHz****30MHz to 1GHz**

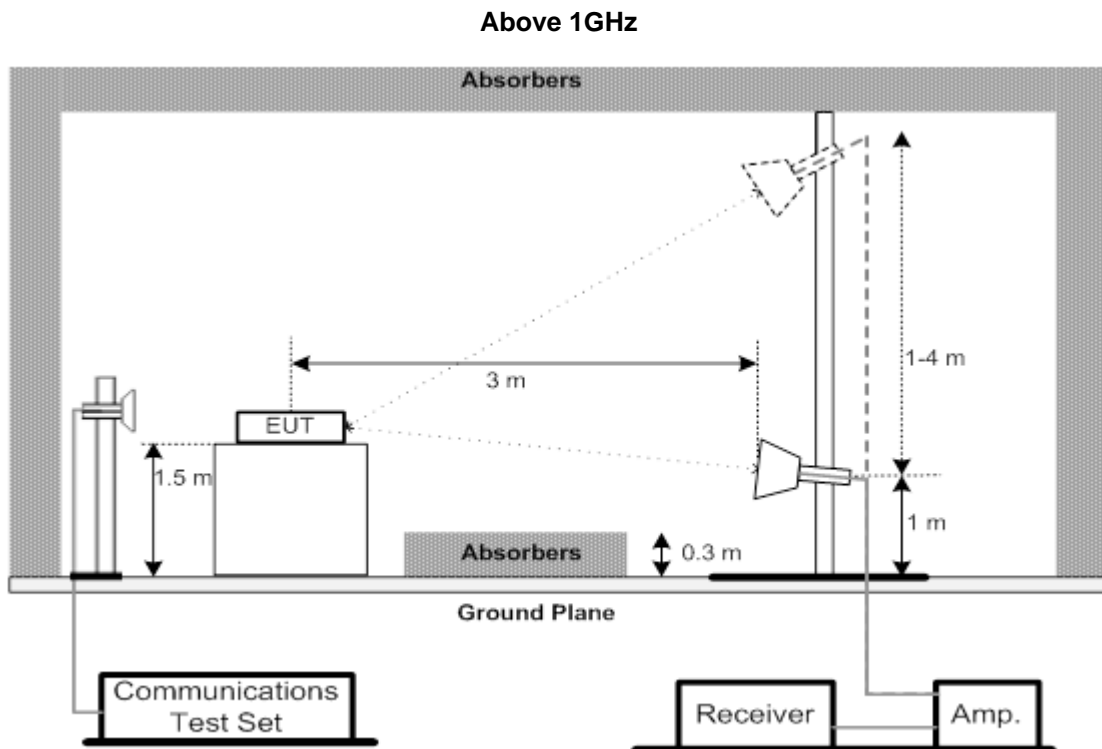

#### 3.4.4 TEST DEVIATION

No deviation

#### 3.4.5 TEST RESULTS (30MHZ TO 1000MHZ)

Please refer to the Appendix D.

#### 3.4.6 TEST RESULTS (ABOVE 1000MHZ)

Please refer to the Appendix E.

### 3.5 BAND EDGE MEASUREMENT

#### 3.5.1 LIMIT

A Power of any emission outside of the authorized operating frequency ranges must be attenuated below the transmitting power (P) by a factor of at least  $43 + 10 \log(P)$  dB. In the 1 MHz bands immediately outside and adjacent to the frequency block a resolution bandwidth of at least one percent of the emission bandwidth of the fundamental emission of the transmitter may be employed.

#### 3.5.2 TEST PROCEDURES

1. All measurements were done at low and high operational frequency range.
2. The center frequency of spectrum is the band edge frequency and span is 2MHz. RB of the spectrum is 15kHz and VB of the spectrum is 43kHz (LTE Bandwidth 1.4MHz).
3. The center frequency of spectrum is the band edge frequency and span is 2MHz. RB of the spectrum is 30kHz and VB of the spectrum is 91kHz (LTE Bandwidth 3MHz).
4. The center frequency of spectrum is the band edge frequency and span is 2MHz. RB of the spectrum is 51kHz and VB of the spectrum is 150kHz (LTE Bandwidth 5MHz).
5. The center frequency of spectrum is the band edge frequency and span is 2MHz. RB of the spectrum is 100kHz and VB of the spectrum is 300kHz (LTE Bandwidth 10MHz).
6. The center frequency of spectrum is the band edge frequency and span is 2MHz. RB of the spectrum is 150kHz and VB of the spectrum is 470kHz (LTE Bandwidth 15MHz).
7. The center frequency of spectrum is the band edge frequency and span is 2MHz. RB of the spectrum is 200kHz and VB of the spectrum is 620kHz (LTE Bandwidth 20MHz).
8. Record the max trace plot into the test report.

#### 3.5.3 TEST SETUP LAYOUT

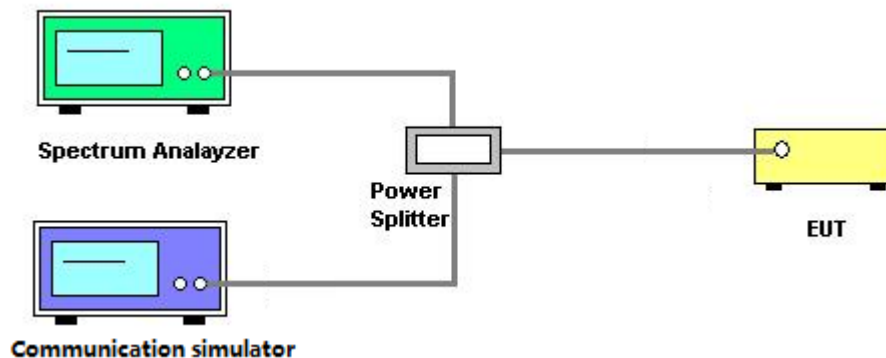

#### 3.5.4 TEST DEVIATION

No deviation

#### 3.5.5 TEST RESULTS

Please refer to the Appendix F.

### 3.6 PEAK TO AVERAGE RATIO MEASUREMENT

#### 3.6.1 LIMIT

In measuring transmissions in this band using an average power technique, the peak to-average ratio (PAR) of the transmission may not exceed 13 dB.

#### 3.6.2 TEST PROCEDURES

1. Set resolution/measurement bandwidth  $\geq$  signal's occupied bandwidth;
2. Set the number of counts to a value that stabilizes the measured CCDF curve;
3. Record the maximum PAPR level associated with a probability of 0.1%.

#### 3.6.3 TEST SETUP LAYOUT

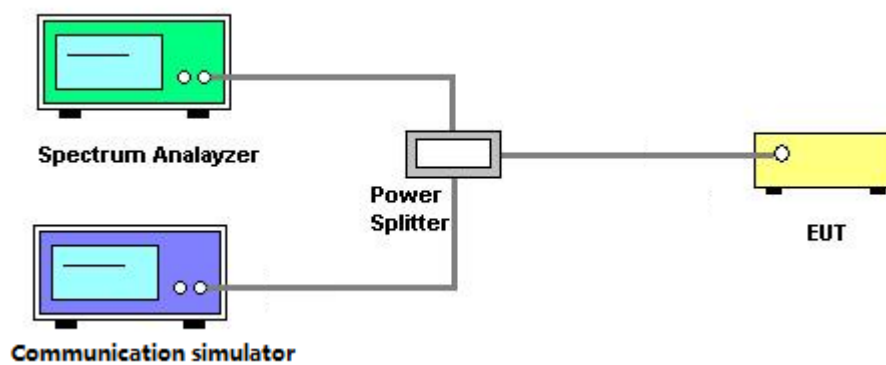

#### 3.6.4 TEST DEVIATION

No deviation

#### 3.6.5 TEST RESULTS

Please refer to the Appendix G.

### 3.7 FREQUENCY STABILITY MEASUREMENT

#### 3.7.1 LIMIT

$\pm 1.5$  ppm is for base and fixed station.  $\pm 2.5$  ppm is for mobile station.

#### 3.7.2 TEST PROCEDURES

1. Device is placed at the oven room. The oven room could control the temperatures and humidity. Power warm up is at least 15 min and power applied should perform before recording frequency error.
2. EUT is connected the external power supply to control the DC input power. The test voltage range is from minimum to maximum working voltage. Each step shall be record the frequency error rate.
3. The temperature range step is 10 degrees in this test items. All temperature levels shall be hold the  $\pm 0.5^{\circ}\text{C}$  during the measurement testing. The each temperature step shall be at least 0.5 hours, consider the EUT could be test under the stability condition.
4. The frequency error was recorded frequency error from the communication simulator.

#### 3.7.3 TEST SETUP LAYOUT

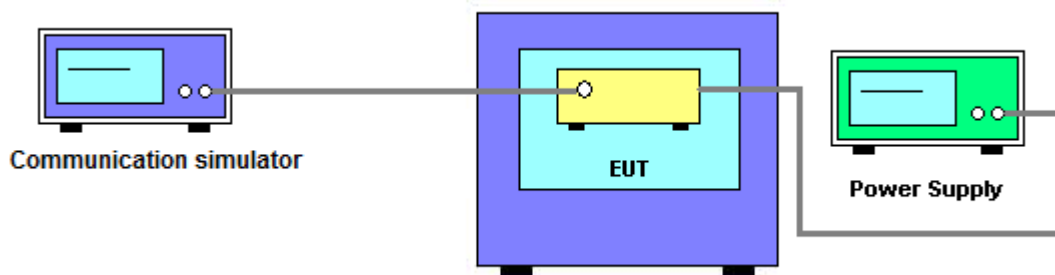

#### 3.7.4 TEST DEVIATION

No deviation

#### 3.7.5 TEST RESULTS

Please refer to the Appendix H.

#### 4. LIST OF MEASUREMENT EQUIPMENTS

Radiated Emission Measurement(9K-30M)					
Item	Kind of Equipment	Manufacturer	Type No.	Serial No.	Calibrated until
1	Loop Antenna	EMCI	EMCI LPA600	275	Mar. 29, 2020
2	EMI Test Receiver	R&S	ESCI	100082	Mar. 29, 2020
3	Measurement Software	Farad	EZ-EMC Ver.NB-03A1-01	N/A	N/A

Radiated Emission Measurement(30M-1G)					
Item	Kind of Equipment	Manufacturer	Type No.	Serial No.	Calibrated until
1	TRILOG Broadband Antenna	Schwarzbeck	VULB 9168	719	Mar. 29, 2020
2	Pre-Amplifier	emci	EMC9135	980400	Mar. 29, 2020
3	MXE EMI Receiver	Keysight	N9038A	MY57150106	Mar. 29, 2020
4	Test Cable	emci	EMC104-SM-SM-7000	170330	Apr. 17, 2020
5	Test Cable	emci	EMC104-SM-SM-1000	170331	Apr. 17, 2020
6	Test Cable	emci	EMC104-SM-NM-3500	170621	Apr. 17, 2020
7	Measurement Software	Farad	EZ-EMC Ver.NB-03A1-01	N/A	N/A
8	Wideband Radio Communication Test	R&S	CMW500	131463	Sep. 01, 2020

Radiated Emission Measurement(1G-18G)					
Item	Kind of Equipment	Manufacturer	Type No.	Serial No.	Calibrated until
1	Pre-Amplifier	emci	EMC184045SE	980409	Mar. 29, 2020
2	Pre-Amplifier	emci	EMC012645SE	980421	Mar. 29, 2020
3	Pre-Amplifier	emci	EMC9135	980400	Mar. 29, 2020
4	Double Ridged Broadband Horn Antenna	Schwarzbeck	BBHA 9120D	9120D-1787	Mar. 29, 2020
5	Double-Ridged Waveguide Horn Antenna	ETS-Lindgren	3116C	00203919	Mar. 29, 2020
6	TRILOG Broadband Antenna	Schwarzbeck	VULB 9168	719	Mar. 29, 2020
7	Cable	N/A	EMC102-SM-SM-6000	170336	Apr. 17, 2020
8	Wideband Radio Communication Test	R&S	CMW500	131463	Sep. 01, 2020



**Conducted Emission & Band Edge & Occupied Bandwidth Measurement**

Item	Kind of Equipment	Manufacturer	Type No.	Serial No.	Calibrated until
1	EXA Spectrum Analyzer	Keysight	N9010A	MY56480579	Mar. 29, 2020
2	Power Divider	JUK	PD-4SF-2060	N/A	N/A
3	Wideband Radio Communication Test	R&S	CMW500	131463	Sep. 01, 2020
4	Spectrum Analyzer	R&S	FSP40	100626	Mar. 29, 2020

**Frequency Stability Measurement**

Item	Kind of Equipment	Manufacturer	Type No.	Serial No.	Calibrated until
1	EXA Spectrum Analyzer	Keysight	N9010A	MY56480579	Mar. 29, 2020
2*	Power Divider	JUK	PD-4SF-2060	N/A	N/A
3	Wideband Radio Communication Test	R&S	CMW500	131463	Sep. 01, 2020
4	Spectrum Analyzer	R&S	FSP40	100626	Mar. 29, 2020
5	Temperature And Humidity Box	Blue pand	BPHS-120B	170616454	Sep. 01, 2020

Remark: "N/A" denotes no model name, serial no. or calibration specified.

All calibration period of equipment list is one year.

\*All calibration period of equipment list is three year

## APPENDIX A - OUTPUT POWER

**Output Power (dBm):**

LTE Band / BW	Modulation	RB Size	RB Offset	Low CH	Mid CH	High CH
				18607CH	18900CH	19193CH
				1850.7MHz	1880MHz	1909.3MHz
2 / 1.4M	QPSK	1	0	23.30	23.58	23.48
		1	2	23.06	23.48	23.30
		1	5	23.15	23.51	23.30
		3	0	23.51	23.58	23.39
		3	1	23.02	23.25	23.72
		3	2	23.29	23.40	23.50
	16QAM	1	0	22.21	22.07	22.01
		1	2	22.39	22.12	22.13
		1	5	22.28	22.22	22.24
		3	0	22.04	22.36	22.14
		3	1	22.49	22.19	21.91
		3	2	22.40	22.39	22.18
		6	0	21.49	21.26	21.51

LTE Band / BW	Modulation	RB Size	RB Offset	Low CH	Mid CH	High CH
				18615CH	18900CH	19185CH
				1851.5MHz	1880MHz	1908.5MHz
2 / 3M	QPSK	1	0	23.26	23.25	23.11
		1	7	23.27	22.97	23.17
		1	14	22.96	23.31	23.20
		8	0	23.41	23.02	23.13
		8	4	23.33	23.34	22.98
		8	7	23.03	23.45	23.13
		15	0	22.25	22.38	22.42
	16QAM	1	0	22.18	22.36	22.01
		1	7	21.98	22.33	21.92
		1	14	22.41	22.53	21.81
		8	0	22.26	22.13	21.96
		8	4	22.45	22.22	21.75
		8	7	22.03	22.51	21.90
		15	0	21.06	21.11	21.51

LTE Band / BW	Modulation	RB Size	RB Offset	Low CH	Mid CH	High CH
				18625CH	18900CH	19175CH
				1852.5MHz	1880MHz	1907.5MHz
2 / 5M	QPSK	1	0	23.37	23.28	23.25
		1	13	23.17	23.16	23.11
		1	24	23.33	23.30	22.98
		12	0	23.31	23.34	23.09
		12	6	23.24	23.53	23.15
		12	11	23.50	23.22	23.03
		25	0	22.31	22.29	22.16
	16QAM	1	0	21.56	21.83	21.64
		1	13	21.82	21.68	21.86
		1	24	21.43	21.62	21.45
		12	0	21.62	22.04	21.76
		12	6	21.79	21.82	21.64
		12	11	21.48	22.01	21.53
		25	0	21.16	21.25	21.23

LTE Band / BW	Modulation	RB Size	RB Offset	Low CH	Mid CH	High CH
				18650CH	18900CH	19150CH
				1855MHz	1880MHz	1905MHz
2 / 10M	QPSK	1	0	23.35	23.42	23.28
		1	25	23.32	23.13	23.31
		1	49	23.19	23.72	23.21
		25	0	23.31	23.69	23.49
		25	13	23.42	23.50	23.17
		25	25	23.29	23.32	23.02
		50	0	22.15	22.26	22.09
	16QAM	1	0	22.05	22.14	21.98
		1	25	21.76	22.22	21.77
		1	49	22.04	22.04	21.82
		25	0	22.21	22.14	21.94
		25	13	21.96	22.37	22.28
		25	25	21.83	22.09	22.27
		50	0	21.21	21.27	21.13

LTE Band / BW	Modulation	RB Size	RB Offset	Low CH	Mid CH	High CH
				18675CH	18900CH	19125CH
				1857.5MHz	1880MHz	1902.5MHz
2 / 15M	QPSK	1	0	23.14	23.23	23.21
		1	38	22.95	23.08	22.94
		1	74	23.33	23.30	23.14
		36	0	23.06	23.06	22.97
		36	18	23.02	23.42	23.30
		36	39	23.35	23.46	22.91
		75	0	22.16	22.30	22.11
	16QAM	1	0	21.81	21.86	21.76
		1	38	21.61	22.08	21.52
		1	74	21.75	21.80	21.58
		36	0	21.69	21.72	21.87
		36	18	21.59	21.77	21.50
		36	39	21.77	21.95	21.99
		75	0	21.47	21.53	21.36

LTE Band / BW	Modulation	RB Size	RB Offset	Low CH	Mid CH	High CH
				18700CH	18900CH	19100CH
				1860MHz	1880MHz	1900MHz
2 / 20M	QPSK	1	0	22.71	22.84	22.77
		1	50	22.84	22.75	22.66
		1	99	22.59	23.04	22.61
		50	0	22.87	23.08	22.88
		50	25	22.98	22.55	22.67
		50	50	22.75	22.68	22.88
		100	0	22.17	22.29	22.16
	16QAM	1	0	21.54	21.70	21.63
		1	50	21.84	21.56	21.65
		1	99	21.35	21.96	21.83
		50	0	21.82	21.69	21.74
		50	25	21.73	21.90	21.75
		50	50	21.76	21.40	21.50
		100	0	21.33	21.50	21.26

LTE Band / BW	Modulation	RB Size	RB Offset	Low CH	Mid CH	High CH
				26047CH	26365CH	26683CH
				1850.7MHz	1882.5MHz	1914.3MHz
25 / 1.4M	QPSK	1	0	23.14	23.25	23.07
		1	2	22.87	23.42	23.03
		1	5	23.11	23.21	23.02
		3	0	23.27	22.99	23.09
		3	1	23.17	23.38	23.12
		3	2	22.88	23.30	23.00
	16QAM	6	0	22.15	22.23	22.11
		1	0	22.06	22.21	21.98
		1	2	22.19	22.45	21.70
		1	5	22.10	22.33	21.73
		3	0	22.09	22.31	22.05
		3	1	21.85	22.15	22.18
		3	2	21.99	22.31	22.10
		6	0	21.36	21.50	21.43

LTE Band / BW	Modulation	RB Size	RB Offset	Low CH	Mid CH	High CH
				26055CH	26365CH	26675CH
				1851.5MHz	1882.5MHz	1913.5MHz
25 / 3M	QPSK	1	0	22.96	23.11	23.01
		1	7	22.90	23.26	22.95
		1	14	23.05	23.20	23.20
		8	0	23.02	22.93	23.00
		8	4	23.22	22.94	22.92
		8	7	22.98	22.98	22.72
		15	0	22.15	22.36	22.25
	16QAM	1	0	21.87	22.02	21.96
		1	7	21.85	21.78	22.07
		1	14	21.79	21.84	22.02
		8	0	21.89	22.22	21.68
		8	4	22.06	22.21	21.98
		8	7	21.86	22.21	22.22
		15	0	21.23	21.40	21.33

LTE Band / BW	Modulation	RB Size	RB Offset	Low CH	Mid CH	High CH
				26065CH	26365CH	26665CH
				1852.5MHz	1882.5MHz	1912.5MHz
25 / 5M	QPSK	1	0	23.03	23.27	23.18
		1	13	22.90	23.02	23.30
		1	24	22.89	23.40	23.09
		12	0	23.16	23.31	22.97
		12	6	23.24	23.20	23.13
		12	11	23.00	23.35	23.30
	16QAM	25	0	22.15	22.37	22.28
		1	0	21.53	21.72	21.66
		1	13	21.61	21.51	21.95
		1	24	21.67	21.62	21.73
		12	0	21.66	21.62	21.52
		12	6	21.32	21.94	21.75
		12	11	21.64	21.85	21.71
		25	0	21.21	21.50	21.33

LTE Band / BW	Modulation	RB Size	RB Offset	Low CH	Mid CH	High CH
				26090CH	26365CH	26640CH
				1855MHz	1882.5MHz	1910MHz
25 / 10M	QPSK	1	0	23.15	23.35	23.21
		1	25	23.15	23.55	23.42
		1	49	23.34	23.61	23.20
		25	0	23.04	23.38	23.08
		25	13	22.93	23.39	23.27
		25	25	23.00	23.11	23.26
	16QAM	50	0	22.46	22.35	22.27
		1	0	21.94	22.12	21.87
		1	25	21.96	22.30	21.77
		1	49	21.81	21.83	21.61
		25	0	22.05	21.93	22.02
		25	13	22.09	22.38	21.83
		25	25	22.01	22.32	22.17
		50	0	21.15	21.36	21.32

LTE Band / BW	Modulation	RB Size	RB Offset	Low CH	Mid CH	High CH
				26115CH	26365CH	26615CH
				1857.5MHz	1882.5MHz	1907.5MHz
25 / 15M	QPSK	1	0	23.43	23.65	23.38
		1	38	23.43	23.42	23.17
		1	74	23.48	23.65	23.24
		36	0	23.22	23.82	23.36
		36	18	23.65	23.57	23.24
		36	39	23.25	23.88	23.55
	16QAM	75	0	22.05	22.30	22.17
		1	0	22.11	22.35	22.39
		1	38	22.00	22.35	22.45
		1	74	21.92	22.56	22.12
		36	0	22.13	22.38	22.40
		36	18	21.93	22.62	22.26
		36	39	21.84	22.41	22.47
		75	0	21.07	21.38	21.28

LTE Band / BW	Modulation	RB Size	RB Offset	Low CH	Mid CH	High CH
				26140CH	26365CH	26590CH
				1860MHz	1882.5MHz	1905MHz
25 / 20M	QPSK	1	0	22.38	22.74	22.56
		1	50	22.67	22.85	22.64
		1	99	22.17	22.75	22.81
		50	0	22.38	22.55	22.59
		50	25	22.52	22.97	22.50
		50	50	22.13	22.91	22.78
	16QAM	100	0	22.18	22.37	22.27
		1	0	21.59	21.76	21.62
		1	50	21.75	21.94	21.51
		1	99	21.55	21.87	21.88
		50	0	21.76	21.50	21.50
		50	25	21.43	21.56	21.42
		50	50	21.78	21.80	21.39
		100	0	21.16	21.35	21.27



**EIRP Power (dBm):**

LTE Band / BW	Modulation	RB Size	RB Offset	Low CH	Mid CH	High CH
				18607CH	18900CH	19193CH
				1850.7MHz	1880MHz	1909.3MHz
2 / 1.4M	QPSK	1	0	24.89	25.17	25.07
		1	2	24.65	25.07	24.89
		1	5	24.74	25.10	24.89
		3	0	25.10	25.17	24.98
		3	1	24.61	24.84	25.31
		3	2	24.88	24.99	25.09
		6	0	23.76	23.87	24.01
	16QAM	1	0	23.80	23.66	23.60
		1	2	23.98	23.71	23.72
		1	5	23.87	23.81	23.83
		3	0	23.63	23.95	23.73
		3	1	24.08	23.78	23.50
		3	2	23.99	23.98	23.77
		6	0	23.08	22.85	23.10

LTE Band / BW	Modulation	RB Size	RB Offset	Low CH	Mid CH	High CH
				18615CH	18900CH	19185CH
				1851.5MHz	1880MHz	1908.5MHz
2 / 3M	QPSK	1	0	24.85	24.84	24.70
		1	7	24.86	24.56	24.76
		1	14	24.55	24.90	24.79
		8	0	25.00	24.61	24.72
		8	4	24.92	24.93	24.57
		8	7	24.62	25.04	24.72
		15	0	23.84	23.97	24.01
	16QAM	1	0	23.77	23.95	23.60
		1	7	23.57	23.92	23.51
		1	14	24.00	24.12	23.4
		8	0	23.85	23.72	23.55
		8	4	24.04	23.81	23.34
		8	7	23.62	24.10	23.49
		15	0	22.65	22.70	23.10

LTE Band / BW	Modulation	RB Size	RB Offset	Low CH	Mid CH	High CH
				18625CH	18900CH	19175CH
				1852.5MHz	1880MHz	1907.5MHz
2 / 5M	QPSK	1	0	24.96	24.87	24.84
		1	13	24.76	24.75	24.70
		1	24	24.92	24.89	24.57
		12	0	24.90	24.93	24.68
		12	6	24.83	25.12	24.74
		12	11	25.09	24.81	24.62
		25	0	23.90	23.88	23.75
	16QAM	1	0	23.15	23.42	23.23
		1	13	23.41	23.27	23.45
		1	24	23.02	23.21	23.04
		12	0	23.21	23.63	23.35
		12	6	23.38	23.41	23.23
		12	11	23.07	23.60	23.12
		25	0	22.75	22.84	22.82

LTE Band / BW	Modulation	RB Size	RB Offset	Low CH	Mid CH	High CH
				18650CH	18900CH	19150CH
				1855MHz	1880MHz	1905MHz
2 / 10M	QPSK	1	0	24.94	25.01	24.87
		1	25	24.91	24.72	24.90
		1	49	24.78	25.31	24.80
		25	0	24.90	25.28	25.08
		25	13	25.01	25.09	24.76
		25	25	24.88	24.91	24.61
		50	0	23.74	23.85	23.68
	16QAM	1	0	23.64	23.73	23.57
		1	25	23.35	23.81	23.36
		1	49	23.63	23.63	23.41
		25	0	23.80	23.73	23.53
		25	13	23.55	23.96	23.87
		25	25	23.42	23.68	23.86
		50	0	22.80	22.86	22.72

LTE Band / BW	Modulation	RB Size	RB Offset	Low CH	Mid CH	High CH
				18675CH	18900CH	19125CH
				1857.5MHz	1880MHz	1902.5MHz
2 / 15M	QPSK	1	0	24.73	24.82	24.80
		1	38	24.54	24.67	24.53
		1	74	24.92	24.89	24.73
		36	0	24.65	24.65	24.56
		36	18	24.61	25.01	24.89
		36	39	24.94	25.05	24.50
		75	0	23.75	23.89	23.70
	16QAM	1	0	23.40	23.45	23.35
		1	38	23.20	23.67	23.11
		1	74	23.34	23.39	23.17
		36	0	23.28	23.31	23.46
		36	18	23.18	23.36	23.09
		36	39	23.36	23.54	23.58
		75	0	23.06	23.12	22.95

LTE Band / BW	Modulation	RB Size	RB Offset	Low CH	Mid CH	High CH
				18700CH	18900CH	19100CH
				1860MHz	1880MHz	1900MHz
2 / 20M	QPSK	1	0	24.30	24.43	24.36
		1	50	24.43	24.34	24.25
		1	99	24.18	24.63	24.20
		50	0	24.46	24.67	24.47
		50	25	24.57	24.14	24.26
		50	50	24.34	24.27	24.47
		100	0	23.76	23.88	23.75
	16QAM	1	0	23.13	23.29	23.22
		1	50	23.43	23.15	23.24
		1	99	22.94	23.55	23.42
		50	0	23.41	23.28	23.33
		50	25	23.32	23.49	23.34
		50	50	23.35	22.99	23.09
		100	0	22.92	23.09	22.85

LTE Band / BW	Modulation	RB Size	RB Offset	Low CH	Mid CH	High CH
				26047CH	26365CH	26683CH
				1850.7MHz	1882.5MHz	1914.3MHz
25 / 1.4M	QPSK	1	0	24.73	24.84	24.66
		1	2	24.46	25.01	24.62
		1	5	24.70	24.80	24.61
		3	0	24.86	24.58	24.68
		3	1	24.76	24.97	24.71
		3	2	24.47	24.89	24.59
	16QAM	6	0	23.74	23.82	23.70
		1	0	23.65	23.8	23.57
		1	2	23.78	24.04	23.29
		1	5	23.69	23.92	23.32
		3	0	23.68	23.9	23.64
		3	1	23.44	23.74	23.77
		3	2	23.58	23.90	23.69
		6	0	22.95	23.09	23.02

LTE Band / BW	Modulation	RB Size	RB Offset	Low CH	Mid CH	High CH
				26055CH	26365CH	26675CH
				1851.5MHz	1882.5MHz	1913.5MHz
25 / 3M	QPSK	1	0	24.55	24.70	24.60
		1	7	24.49	24.85	24.54
		1	14	24.64	24.79	24.79
		8	0	24.61	24.52	24.59
		8	4	24.81	24.53	24.51
		8	7	24.57	24.57	24.31
		15	0	23.74	23.95	23.84
	16QAM	1	0	23.46	23.61	23.55
		1	7	23.44	23.37	23.66
		1	14	23.38	23.43	23.61
		8	0	23.48	23.81	23.27
		8	4	23.65	23.80	23.57
		8	7	23.45	23.80	23.81
		15	0	22.82	22.99	22.92

LTE Band / BW	Modulation	RB Size	RB Offset	Low CH	Mid CH	High CH
				26065CH	26365CH	26665CH
				1852.5MHz	1882.5MHz	1912.5MHz
25 / 5M	QPSK	1	0	24.62	24.86	24.77
		1	13	24.49	24.61	24.89
		1	24	24.48	24.99	24.68
		12	0	24.75	24.90	24.56
		12	6	24.83	24.79	24.72
		12	11	24.59	24.94	24.89
		25	0	23.74	23.96	23.87
	16QAM	1	0	23.12	23.31	23.25
		1	13	23.20	23.1	23.54
		1	24	23.26	23.21	23.32
		12	0	23.25	23.21	23.11
		12	6	22.91	23.53	23.34
		12	11	23.23	23.44	23.30
		25	0	22.80	23.09	22.92

LTE Band / BW	Modulation	RB Size	RB Offset	Low CH	Mid CH	High CH
				26090CH	26365CH	26640CH
				1855MHz	1882.5MHz	1910.0MHz
25 / 10M	QPSK	1	0	24.74	24.94	24.80
		1	25	24.74	25.14	25.01
		1	49	24.93	25.20	24.79
		25	0	24.63	24.97	24.67
		25	13	24.52	24.98	24.86
		25	25	24.59	24.70	24.85
		50	0	24.05	23.94	23.86
	16QAM	1	0	23.53	23.71	23.46
		1	25	23.55	23.89	23.36
		1	49	23.40	23.42	23.20
		25	0	23.64	23.52	23.61
		25	13	23.68	23.97	23.42
		25	25	23.60	23.91	23.76
		50	0	22.74	22.95	22.91

LTE Band / BW	Modulation	RB Size	RB Offset	Low CH	Mid CH	High CH
				26115CH	26365CH	26615CH
				1857.5MHz	1882.5MHz	1907.5MHz
25 / 15M	QPSK	1	0	25.02	25.24	24.97
		1	38	25.02	25.01	24.76
		1	74	25.07	25.24	24.83
		36	0	24.81	25.41	24.95
		36	18	25.24	25.16	24.83
		36	39	24.84	25.47	25.14
	16QAM	75	0	23.64	23.89	23.76
		1	0	23.70	23.94	23.98
		1	38	23.59	23.94	24.04
		1	74	23.51	24.15	23.71
		36	0	23.72	23.97	23.99
		36	18	23.52	24.21	23.85
		36	39	23.43	24.00	24.06
		75	0	22.66	22.97	22.87

LTE Band / BW	Modulation	RB Size	RB Offset	Low CH	Mid CH	High CH
				26140CH	26365CH	26590CH
				1860MHz	1882.5MHz	1905MHz
25 / 20M	QPSK	1	0	23.97	24.33	24.15
		1	50	24.26	24.44	24.23
		1	99	23.76	24.34	24.40
		50	0	23.97	24.14	24.18
		50	25	24.11	24.56	24.09
		50	50	23.72	24.50	24.37
	16QAM	100	0	23.77	23.96	23.86
		1	0	23.18	23.35	23.21
		1	50	23.34	23.53	23.10
		1	99	23.14	23.46	23.47
		50	0	23.35	23.09	23.09
		50	25	23.02	23.15	23.01
		50	50	23.37	23.39	22.98
		100	0	22.75	22.94	22.86

## APPENDIX B - OCCUPIED BANDWIDTH

LTE Band 2_1.4M					
QPSK			16QAM		
Channel	Frequency (MHz)	99% Occupied Bandwidth (MHz)	Channel	Frequency (MHz)	99% Occupied Bandwidth (MHz)
18607	1850.7	1.0875	18607	1850.7	1.0884
18900	1880	1.0937	18900	1880	1.0914
19193	1909.3	1.1032	19193	1909.3	1.0941
Channel	Frequency (MHz)	26dB Bandwidth (MHz)	Channel	Frequency (MHz)	26dB Bandwidth (MHz)
18607	1850.7	1.2830	18607	1850.7	1.3070
18900	1880	1.3140	18900	1880	1.2910
19193	1909.3	1.3010	19193	1909.3	1.2910



## Spectrum Plot

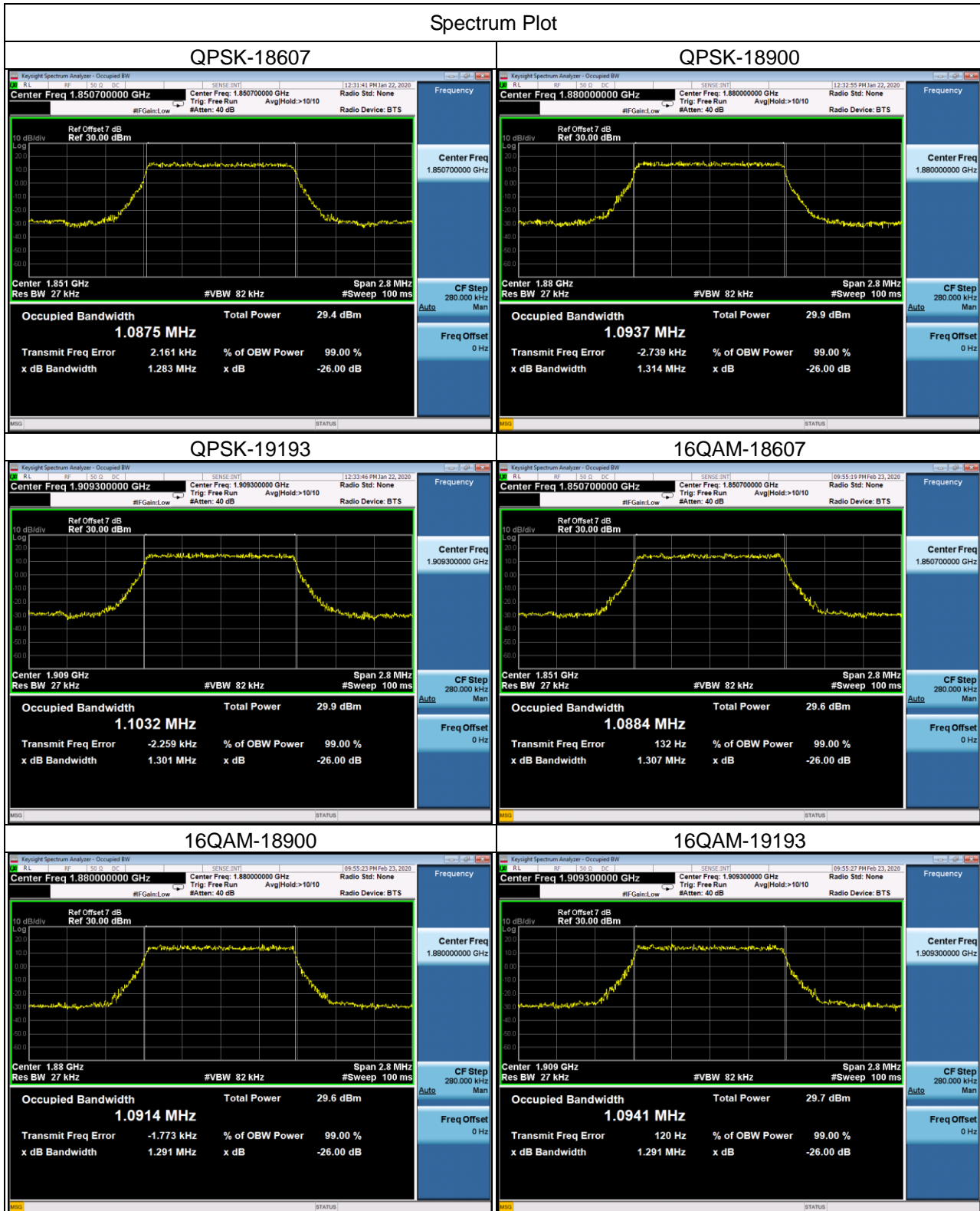

LTE Band 2_3M					
QPSK			16QAM		
Channel	Frequency (MHz)	99% Occupied Bandwidth (MHz)	Channel	Frequency (MHz)	99% Occupied Bandwidth (MHz)
18615	1851.5	2.6998	18615	1851.5	2.7044
18900	1880	2.7004	18900	1880	2.6978
19185	1908.5	2.7006	19185	1908.5	2.6979
Channel	Frequency (MHz)	26dB Bandwidth (MHz)	Channel	Frequency (MHz)	26dB Bandwidth (MHz)
18615	1851.5	2.9910	18615	1851.5	2.9780
18900	1880	2.9960	18900	1880	2.9830
19185	1908.5	2.9830	19185	1908.5	2.9990

## Spectrum Plot

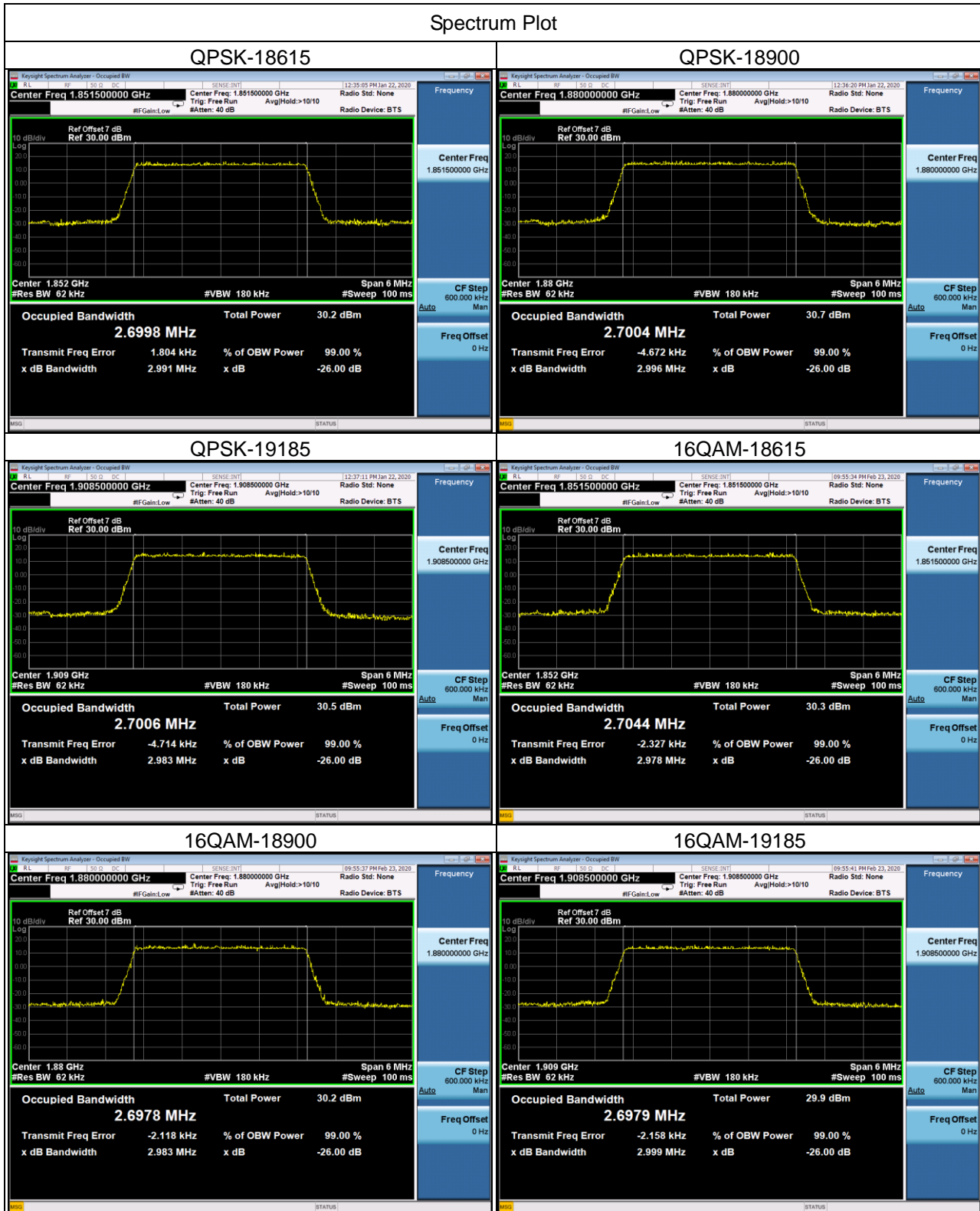

LTE Band 2_5M					
QPSK			16QAM		
Channel	Frequency (MHz)	99% Occupied Bandwidth (MHz)	Channel	Frequency (MHz)	99% Occupied Bandwidth (MHz)
18625	1852.5	4.5222	18625	1852.5	4.4952
18900	1880	4.5049	18900	1880	4.4929
19175	1907.5	4.5025	19175	1907.5	4.4938
Channel	Frequency (MHz)	26dB Bandwidth (MHz)	Channel	Frequency (MHz)	26dB Bandwidth (MHz)
18625	1852.5	5.0040	18625	1852.5	5.0350
18900	1880	4.9610	18900	1880	4.9620
19175	1907.5	4.9660	19175	1907.5	4.9380

## Spectrum Plot

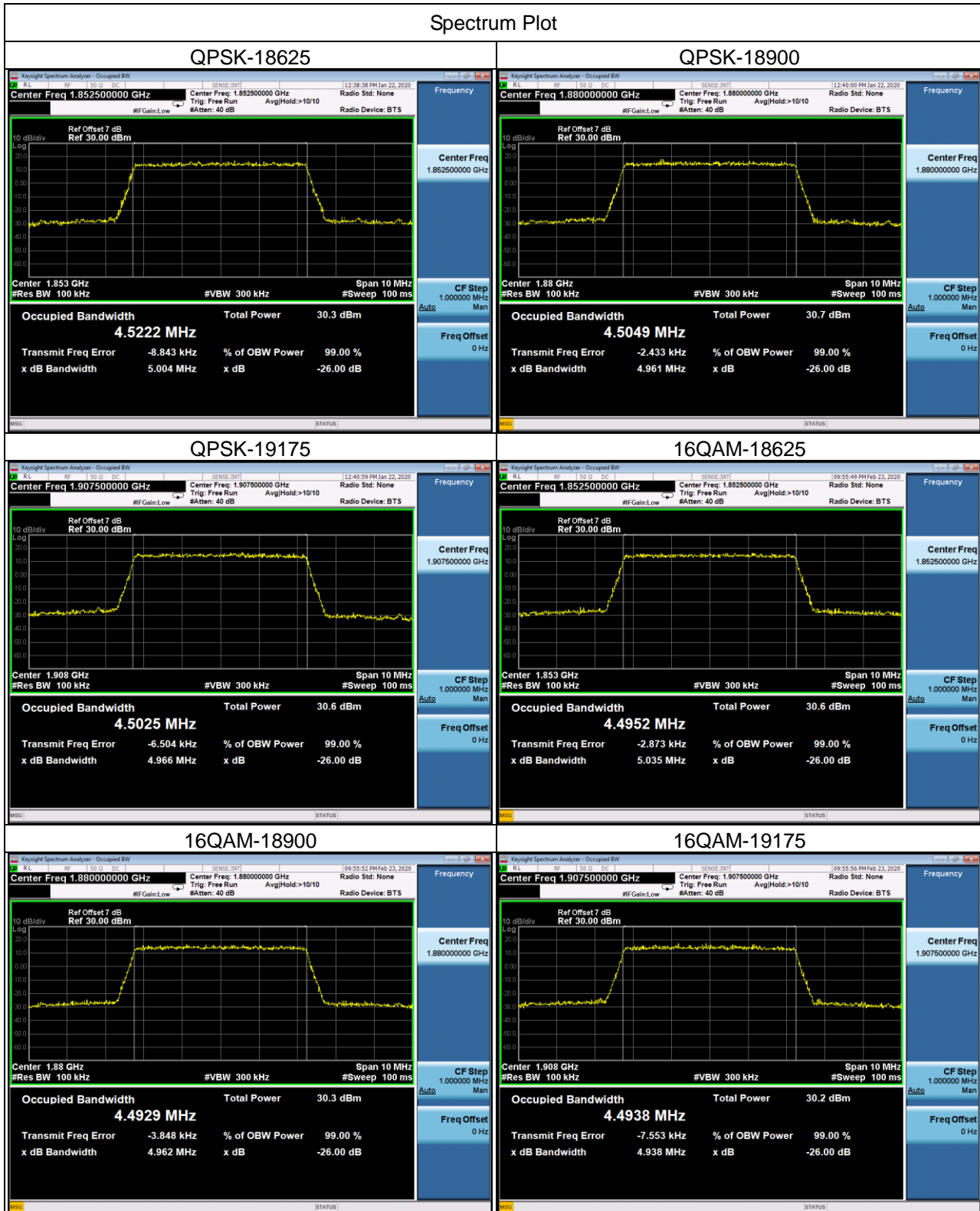

LTE Band 2_10M					
QPSK			16QAM		
Channel	Frequency (MHz)	99% Occupied Bandwidth (MHz)	Channel	Frequency (MHz)	99% Occupied Bandwidth (MHz)
18650	1855	8.9716	18650	1855	8.9635
18900	1880	8.9593	18900	1880	8.9482
19150	1905	8.9685	19150	1905	8.9710
Channel	Frequency (MHz)	26dB Bandwidth (MHz)	Channel	Frequency (MHz)	26dB Bandwidth (MHz)
18650	1855	9.8960	18650	1855	9.8430
18900	1880	9.8580	18900	1880	9.9320
19150	1905	9.8820	19150	1905	9.8700

## Spectrum Plot

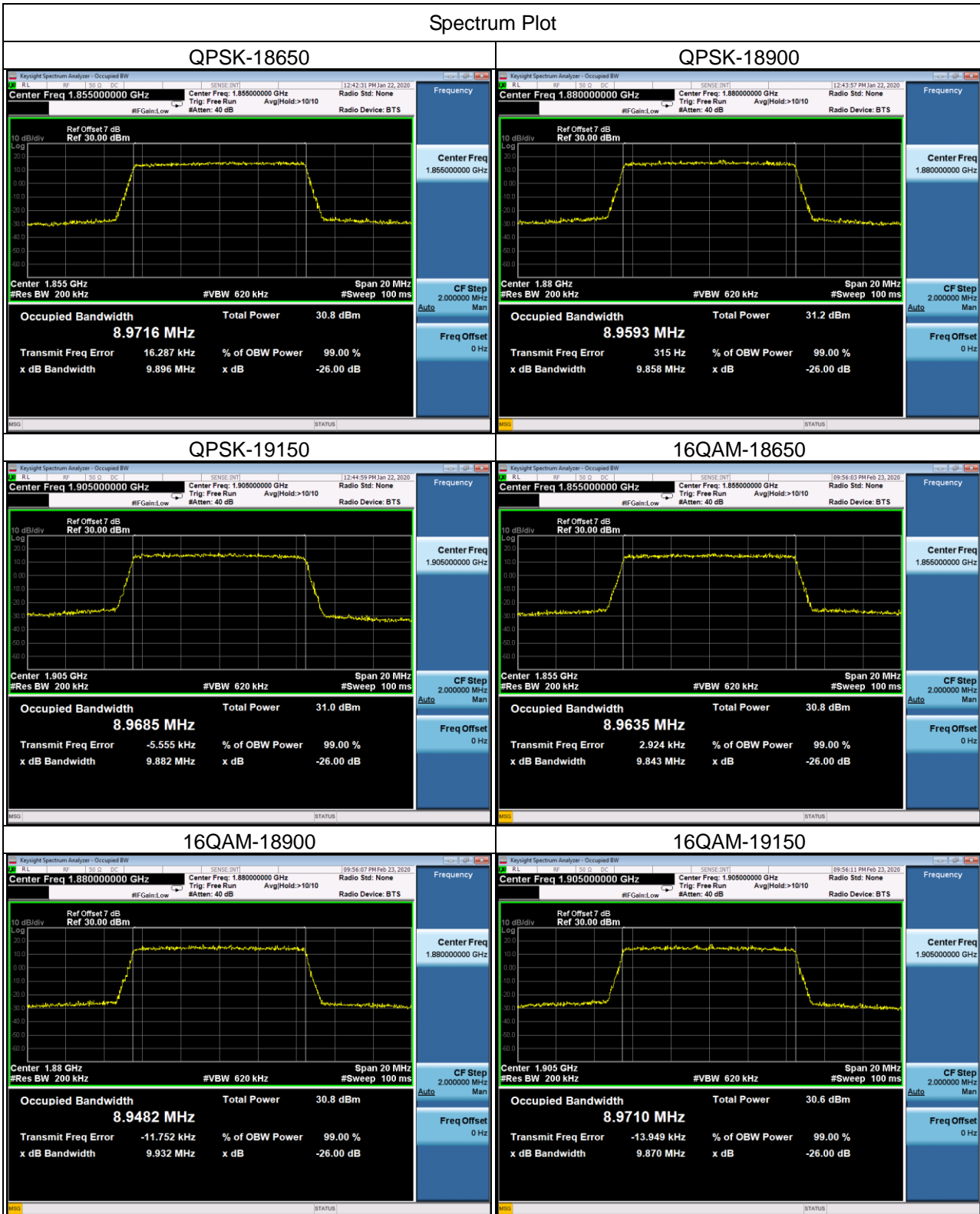

LTE Band 2_15M					
QPSK			16QAM		
Channel	Frequency (MHz)	99% Occupied Bandwidth (MHz)	Channel	Frequency (MHz)	99% Occupied Bandwidth (MHz)
18675	1857.5	13.4290	18675	1857.5	13.4220
18900	1880	13.4350	18900	1880	13.4180
19125	1902.5	13.3630	19125	1902.5	13.3860
Channel	Frequency (MHz)	26dB Bandwidth (MHz)	Channel	Frequency (MHz)	26dB Bandwidth (MHz)
18675	1857.5	14.5900	18675	1857.5	14.6500
18900	1880	14.6000	18900	1880	14.7100
19125	1902.5	14.6000	19125	1902.5	14.5800



## Spectrum Plot

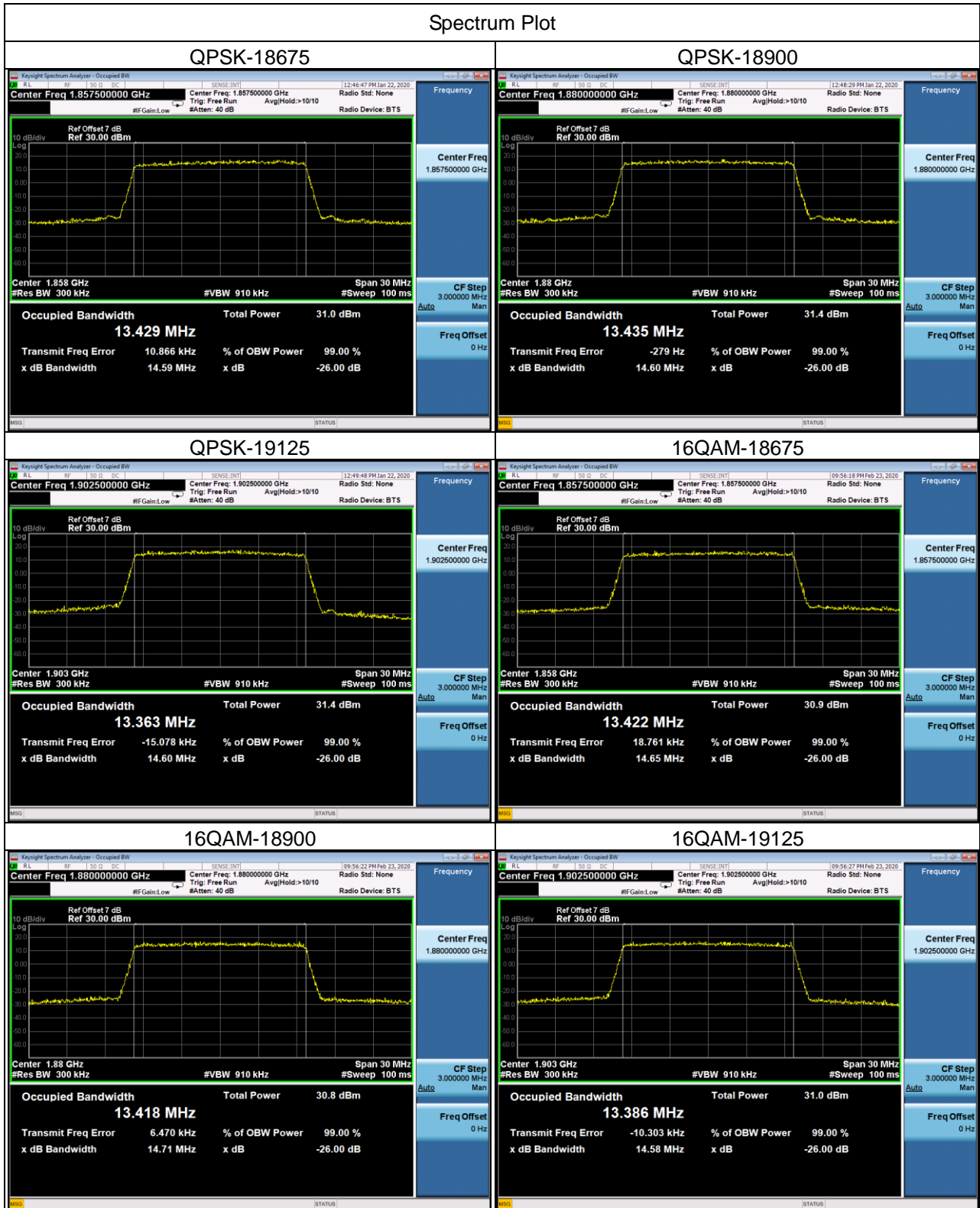

LTE Band 2_20M					
QPSK			16QAM		
Channel	Frequency (MHz)	99% Occupied Bandwidth (MHz)	Channel	Frequency (MHz)	99% Occupied Bandwidth (MHz)
18700	1860	17.8740	18700	1860	17.8830
18900	1880	17.9070	18900	1880	17.8760
19100	1900	17.8370	19100	1900	17.8510
Channel	Frequency (MHz)	26dB Bandwidth (MHz)	Channel	Frequency (MHz)	26dB Bandwidth (MHz)
18700	1860	19.2700	18700	1860	19.2600
18900	1880	19.4800	18900	1880	19.3700
19100	1900	19.4300	19100	1900	19.4300

## Spectrum Plot

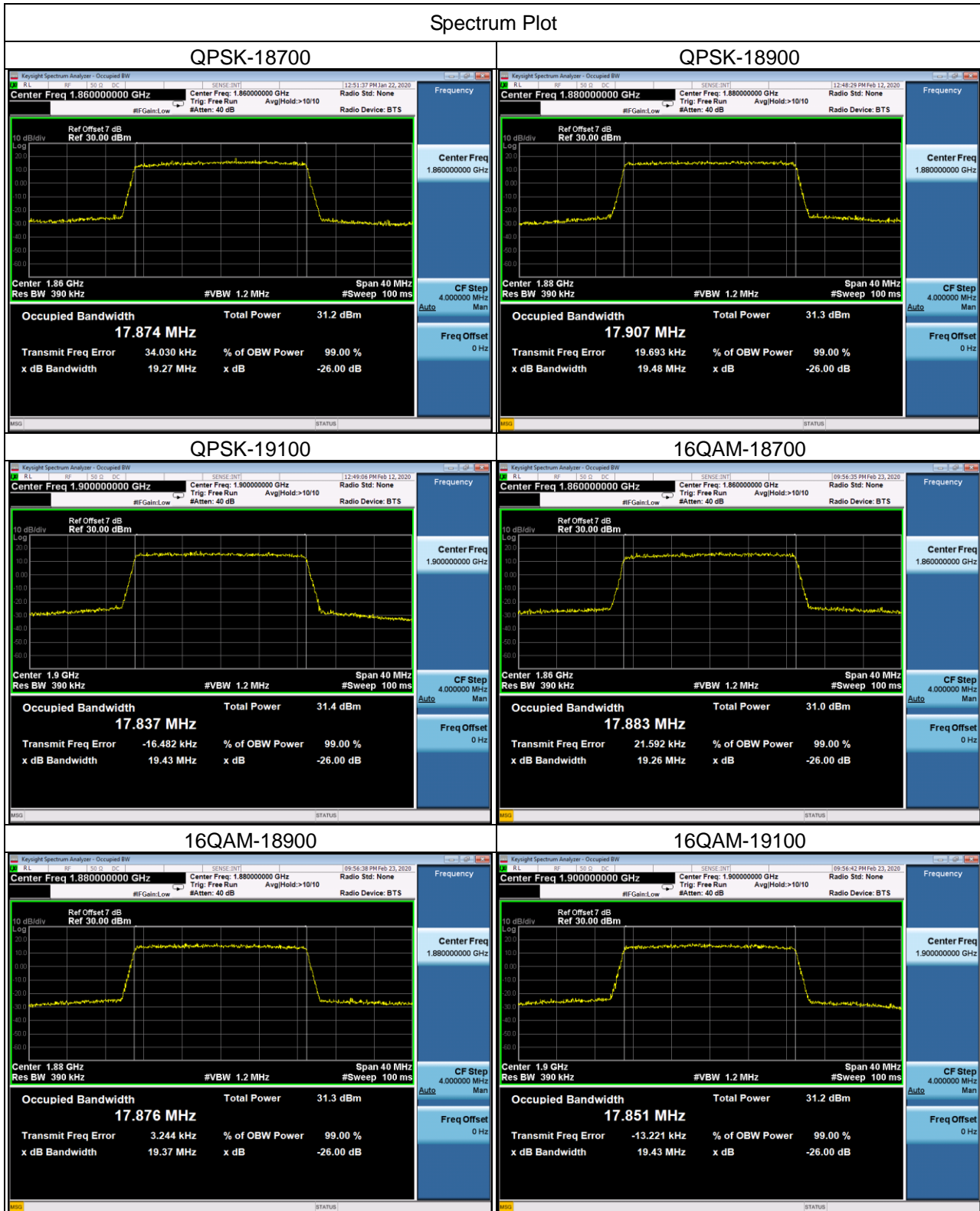

LTE Band 25_1.4M					
QPSK			16QAM		
Channel	Frequency (MHz)	99% Occupied Bandwidth (MHz)	Channel	Frequency (MHz)	99% Occupied Bandwidth (MHz)
26047	1850.7	1.0867	26047	1850.7	1.0897
26365	1882.5	1.0912	26365	1882.5	1.0977
26683	1914.3	1.1018	26683	1914.3	1.0903
Channel	Frequency (MHz)	26dB Bandwidth (MHz)	Channel	Frequency (MHz)	26dB Bandwidth (MHz)
26047	1850.7	1.2850	26047	1850.7	1.3030
26365	1882.5	1.3150	26365	1882.5	1.2970
26683	1914.3	1.3140	26683	1914.3	1.3020

## Spectrum Plot

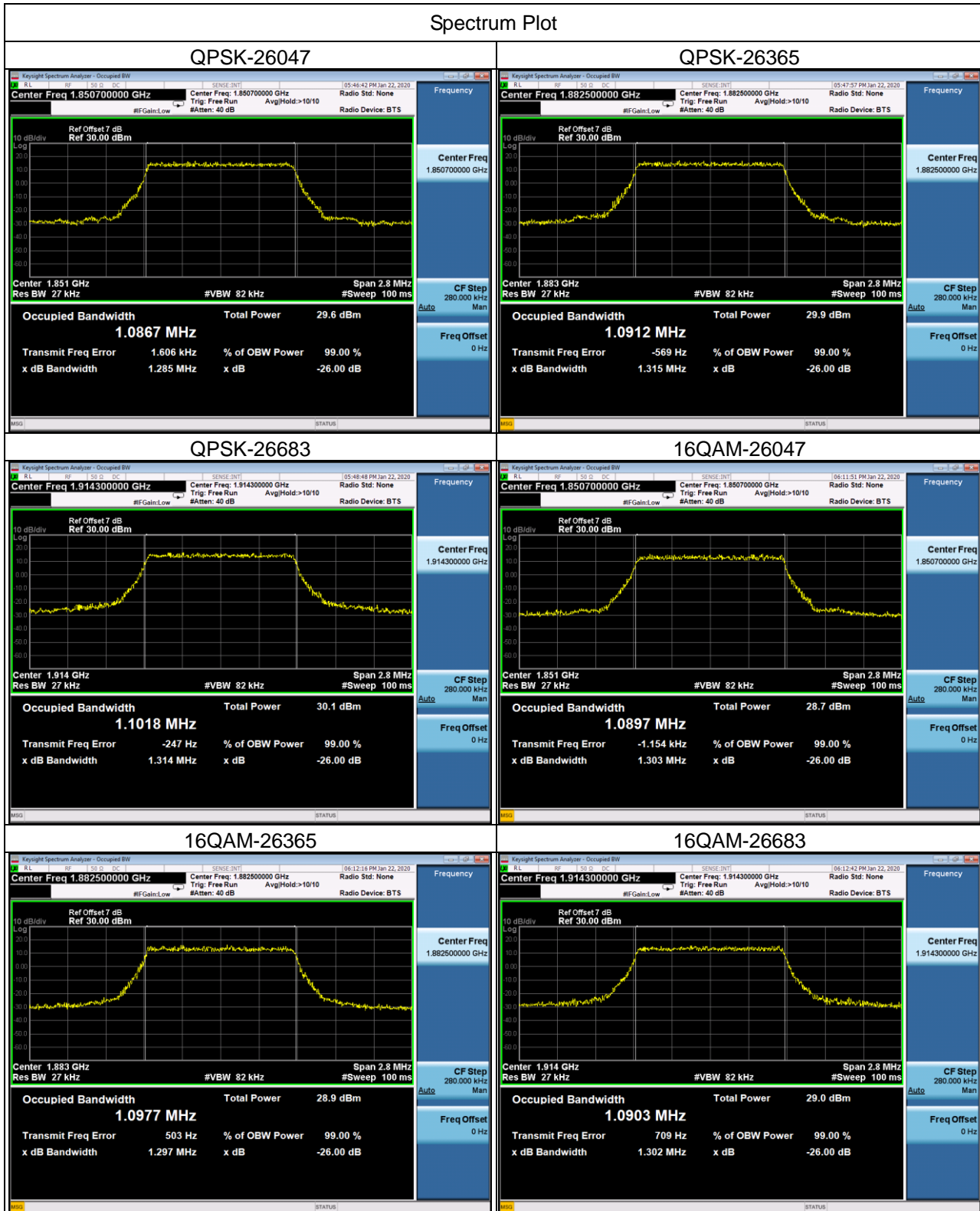

LTE Band 25_3M					
QPSK			16QAM		
Channel	Frequency (MHz)	99% Occupied Bandwidth (MHz)	Channel	Frequency (MHz)	99% Occupied Bandwidth (MHz)
26055	1851.5	2.6952	26055	1851.5	2.6981
26365	1882.5	2.6997	26365	1882.5	2.7010
26675	1913.5	2.6948	26675	1913.5	2.6973
Channel	Frequency (MHz)	26dB Bandwidth (MHz)	Channel	Frequency (MHz)	26dB Bandwidth (MHz)
26055	1851.5	2.9780	26055	1851.5	2.9880
26365	1882.5	2.9970	26365	1882.5	2.9970
26675	1913.5	2.9690	26675	1913.5	2.9930

## Spectrum Plot

