



RF TEST REPORT

Applicant Quetel Wireless Solutions Co., Ltd
FCC ID XMR201911SC600WF
Product Smart Module
Brand Quetel
Model SC600T-WF, SC600Y-WF
Marketing Quetel SC600T-WF, Quetel SC600Y-WF
Report No. R1910A0590-R3
Issue Date November 18, 2019

TA Technology (Shanghai) Co., Ltd. tested the above equipment in accordance with the requirements in **FCC CFR47 Part 15E (2018)**. The test results show that the equipment tested is capable of demonstrating compliance with the requirements as documented in this report.

Performed by: Peng Tao

Approved by: Kai Xu

TA Technology (Shanghai) Co., Ltd.

No.145, Jintang Rd, Tangzhen Industry Park, Pudong Shanghai, China

TEL: +86-021-50791141/2/3

FAX: +86-021-50791141/2/3-8000



TABLE OF CONTENT

1. Test Laboratory	4
1.1. Notes of the test report.....	4
1.2. Testing Location.....	4
2. General Description of Equipment under Test.....	5
2.1. Applicant and Manufacturer Information.....	5
2.2. General information.....	5
3. Applied Standards	6
4. Test Configuration	7
5. Test Case Results	9
5.1. Average Power Output –Conducted.....	9
5.2. Unwanted Emission	17
5.3. Conducted Emission	104
6. Main Test Instruments.....	107



Summary of measurement results

Number	Test Case	Clause in FCC rules	Verdict
1	Average conducted output power	15.407(a)	PASS
2	Unwanted Emissions	15.407(b)	PASS
3	Conducted Emissions	15.207	PASS
Date of Testing: October 16, 2019 ~ November 1, 2019			

Only Conducted power , Unwanted Emissions and Conducted Emissions were tested for SC600T-WF, SC600Y-WF in this report. Other conducted test items refer to the SC600Y-NA ,SC600T-NA Module report (Report No. : HR/2019/5000603).



1. Test Laboratory

1.1. Notes of the test report

This report shall not be reproduced in full or partial, without the written approval of **TA technology (shanghai) co., Ltd.** The results documented in this report apply only to the tested sample, under the conditions and modes of operation as described herein. Measurement Uncertainties were not taken into account and are published for informational purposes only. This report is written to support regulatory compliance of the applicable standards stated above.

1.2. Testing Location

Company: TA Technology (Shanghai) Co., Ltd.
Address: No.145, Jintang Rd, Tangzhen Industry Park, Pudong
City: Shanghai
Post code: 201201
Country: P. R. China
Contact: Xu Kai
Telephone: +86-021-50791141/2/3
Fax: +86-021-50791141/2/3-8000
Website: <http://www.ta-shanghai.com>
E-mail: xukai@ta-shanghai.com

2. General Description of Equipment under Test

2.1. Applicant and Manufacturer Information

Applicant	Quectel Wireless Solutions Co., Ltd
Applicant address	Building 5, Shanghai Business Park Phase III (Area B), No.1016 Tianlin Road, Minhang District, Shanghai, China 200233
Manufacturer	Quectel Wireless Solutions Co., Ltd
Manufacturer address	Building 5, Shanghai Business Park Phase III (Area B), No.1016 Tianlin Road, Minhang District, Shanghai, China 200233

2.2. General information

EUT Description	
Model	SC600T-WF, SC600Y-WF
IMEI	P1A19IJ58000023
Hardware Version	R1.0
Software Version	SC600YWFPAR05A04
Power Supply	External Power Supply
Antenna Type	The EUT don't have standard Adapter and Antenna. The adapter and Antenna used for testing in this report is the after-market accessory.
Antenna Gain	5 dBi
Directional Gain	NA
Test Mode(s)	U-NII-1(5150MHz-5250MHz) U-NII-2A(5250MHz-5350MHz) U-NII-2C(5470MHz-5725MHz without 5600MHz -5650MHz) U-NII-3(5725MHz-5850MHz)
Modulation Type	802.11a/n (HT20/HT40) : OFDM 802.11ac (VHT20/VHT40/VHT80): OFDM
Max. Conducted Power	13.50 dBm
Operating Frequency Range(s)	U-NII-1: 5150-5250MHz U-NII-2A:5250-5350MHz U-NII-2C:5470-5725MHz (without 5600MHz -5650MHz) U-NII-3: 5725-5850MHz
Operating temperature range:	-35 ° C to 65° C
Operating voltage range:	3.55 V to 4.4 V
State AC voltage:	3.8V
Note:1. The information of the EUT is declared by the manufacturer.	



3. Applied Standards

According to the specifications of the manufacturer, it must comply with the requirements of the following standards:

Test standards:

FCC CFR47 Part 15E (2018) Unlicensed National Information Infrastructure Devices

ANSI C63.10 (2013)

Reference standard:

KDB 789033 D02 General UNII Test Procedures New Rules v02r01

4. Test Configuration

Test Mode

The EUT has been associated with peripherals and configuration operated in a manner tended to maximize its emission characteristics in a typical application.

The radiated emission was measured in the following position: EUT stand-up position (Z axis), lie-down position (X, Y axis). The worst emission was found in lie-down position (X axis) and the worst case was recorded.

In order to find the worst case condition, Pre-tests are needed at the presence of different data rate. Preliminary tests have been done on all the configuration for confirming worst case. Data rate below means worst-case rate of each test item.

Worst-case data rates are shown as following table.

Band	Data Rate
802.11a	6 Mbps
802.11n HT20	MCS0
802.11n HT40	MCS0
802.11ac VHT20	MCS0
802.11ac VHT40	MCS0
802.11ac VHT80	MCS0

**Wireless Technology and Frequency Range**

Wireless Technology		Bandwidth	Channel	Frequency
Wi-Fi	U-NII-1	20 MHz	36	5180MHz
			44	5220MHz
			48	5240MHz
		40 MHz	38	5190MHz
			46	5230MHz
			42	5210MHz
	U-NII-2A	20 MHz	52	5260MHz
			60	5300MHz
			64	5320MHz
		40 MHz	54	5270MHz
			62	5310MHz
			58	5290MHz
	U-NII-2C	20 MHz	100	5500MHz
			116	5580MHz
			140	5700MHz
		40 MHz	102	5510MHz
			134	5670MHz
			142	5710MHz
	U-NII-3	20 MHz	106	5530MHz
			149	5745MHz
			157	5785MHz
40 MHz		165	5825MHz	
		151	5755MHz	
		159	5795MHz	
80 MHz	155	5775MHz		
Does this device support TPC Function? <input type="checkbox"/> Yes <input checked="" type="checkbox"/> No				
Does this device support TDWR Band? <input type="checkbox"/> Yes <input checked="" type="checkbox"/> No				

5. Test Case Results

5.1. Average Power Output –Conducted

Ambient condition

Temperature	Relative humidity	Pressure
23°C ~25°C	45%~50%	101.5kPa

Methods of Measurement

During the process of the testing, The EUT was connected to the average power meter through an external attenuator and a known loss cable. The EUT is max power transmission with proper modulation. We use Maximum average Conducted Output Power Level Method in KDB789033 for this test

Test Setup

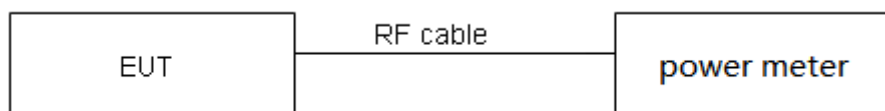

Limits

Rule FCC Part 15.407(a)(1)(2)(3)

(1) For the band 5.15-5.25 GHz.

(i) For an outdoor access point operating in the band 5.15-5.25 GHz, the maximum conducted output power over the frequency band of operation shall not exceed 1 W provided the maximum antenna gain does not exceed 6 dBi. In addition, the maximum power spectral density shall not exceed 17 dBm in any 1 megahertz band. If transmitting antennas of directional gain greater than 6 dBi are used, both the maximum conducted output power and the maximum power spectral density shall be reduced by the amount in dB that the directional gain of the antenna exceeds 6 dBi. The maximum e.i.r.p. at any elevation angle above 30 degrees as measured from the horizon must not exceed 125 mW (21 dBm).

(ii) For an indoor access point operating in the band 5.15-5.25 GHz, the maximum conducted output power over the frequency band of operation shall not exceed 1 W provided the maximum antenna gain does not exceed 6 dBi. In addition, the maximum power spectral density shall not exceed 17 dBm in any 1 megahertz band. If transmitting antennas of directional gain greater than 6 dBi are used, both the maximum conducted output power and the maximum power spectral density shall be reduced by the amount in dB that the directional gain of the antenna exceeds 6 dBi.

(iii) For fixed point-to-point access points operating in the band 5.15-5.25 GHz, the maximum conducted output power over the frequency band of operation shall not exceed 1 W. In addition, the maximum power spectral density shall not exceed 17 dBm in any 1 megahertz band. Fixed point-to-point U-NII devices may employ antennas with directional gain up to 23 dBi without any corresponding reduction in the maximum conducted output power or maximum power spectral density. For fixed point-to-point transmitters that employ a directional antenna gain greater than 23



dBi, a 1 dB reduction in maximum conducted output power and maximum power spectral density is required for each 1 dB of antenna gain in excess of 23 dBi. Fixed, point-to-point operations exclude the use of point-to-multipoint systems, omnidirectional applications, and multiple collocated transmitters transmitting the same information. The operator of the U-NII device, or if the equipment is professionally installed, the installer, is responsible for ensuring that systems employing high gain directional antennas are used exclusively for fixed, point-to-point operations.

(iv) For client devices in the 5.15-5.25 GHz band, the maximum conducted output power over the frequency band of operation shall not exceed 250 mW provided the maximum antenna gain does not exceed 6 dBi. In addition, the maximum power spectral density shall not exceed 11 dBm in any 1 megahertz band. If transmitting antennas of directional gain greater than 6 dBi are used, both the maximum conducted output power and the maximum power spectral density shall be reduced by the amount in dB that the directional gain of the antenna exceeds 6 dBi.

(2) For the 5.25-5.35 GHz bands, the maximum conducted output power over the frequency bands of operation shall not exceed the lesser of 250 mW or $11 \text{ dBm} + 10 \log B$, where B is the 26 dB emission bandwidth in megahertz. In addition, the maximum power spectral density shall not exceed 11 dBm in any 1 megahertz band. If transmitting antennas of directional gain greater than 6 dBi are used, both the maximum conducted output power and the maximum power spectral density shall be reduced by the amount in dB that the directional gain of the antenna exceeds 6 dBi.

(3) For the band 5.725-5.85 GHz, the maximum conducted output power over the frequency band of operation shall not exceed 1 W. In addition, the maximum power spectral density shall not exceed 30 dBm in any 500-kHz band. If transmitting antennas of directional gain greater than 6 dBi are used, both the maximum conducted output power and the maximum power spectral density shall be reduced by the amount in dB that the directional gain of the antenna exceeds 6 dBi.

Measurement Uncertainty

The assessed measurement uncertainty to ensure 95% confidence level for the normal distribution is with the coverage factor $k = 2$, $U = 0.44 \text{ dB}$.



Test Results

Band	T _{on} (ms)	T _(on+off) (ms)	Duty cycle	Duty cycle correction Factor(dB)
802.11a	1.36	1.56	0.87	0.60
802.11n HT20	1.28	1.48	0.86	0.63
802.11n HT40	0.49	0.69	0.71	1.47
802.11ac VHT20	0.98	1.18	0.83	0.80
802.11ac VHT40	0.49	0.69	0.71	1.47
802.11ac VHT80	0.25	0.45	0.55	2.62

Note: when Duty cycle>0.98, Duty cycle correction Factor not required.

Packet Type	Single Antenna Power Index											
	CH36	CH44	CH48	CH52	CH60	CH64	CH100	CH116	CH140	CH149	CH157	CH165
802.11a	13	13	13	13	13	13	13	13	13	13	13	13
802.11n HT20	13	13	13	13	13	13	13	13	13	13	13	13
802.11ac VHT20	13	13	13	13	13	13	13	13	13	13	13	13
Packet Type	CH38	CH46	CH54	CH62	CH102	CH110	CH134	CH151	CH159	/	/	/
802.11n HT40	13	13	13	13	13	13	13	13	13	/	/	/
802.11ac VHT40	13	13	13	13	13	13	13	13	13	/	/	/
Packet Type	CH42	CH58	CH106	CH155	/	/	/	/	/	/	/	/
802.11ac VHT80	12	12	12	12	/	/	/	/	/	/	/	/



Network Standards		Channel/Frequency (MHz)	B=26 dB bandwidth (MHz)	Limit 11 dBm + 10 log B (dBm)	Final Limit(dBm)	
U-NII-2A	802.11a	52/5260	22.26	24.48>24	24	
		60/5300	22.14	24.45>24	24	
		64/5320	22.34	24.49>24	24	
	802.11n HT20	52/5260	22.50	24.52>24	24	
		60/5300	22.62	24.54>24	24	
		64/5320	22.90	24.60>24	24	
	802.11n HT40	54/5270	43.24	27.36>24	24	
		62/5310	43.80	27.41>24	24	
	802.11ac VHT20	52/5260	22.18	24.46>24	24	
		60/5300	22.22	24.47>24	24	
		64/5320	22.30	24.48>24	24	
	802.11ac VHT40	54/5270	43.24	27.36>24	24	
62/5310		43.24	27.36>24	24		
802.11ac VHT80	58/5290	84.56	30.27>24	24		
U-NII-2C	802.11a	100/5500	22.24	24.47>24	24	
		116/5580	22.30	24.48>24	24	
		140/5700	22.06	24.44>24	24	
	802.11n HT20	100/5500	22.70	24.56>24	24	
		116/5580	22.58	24.54>24	24	
		140/5700	22.70	24.56>24	24	
	802.11n HT40	102/5510	43.72	27.41>24	24	
		110/5550	42.92	27.33>24	24	
		134/5670	44.04	27.44>24	24	
	802.11ac VHT20	100/5500	22.18	24.46>24	24	
		116/5580	22.22	24.47>24	24	
		140/5700	22.23	24.47>24	24	
	802.11ac VHT40	102/5510	43.08	27.34>24	24	
		110/5550	43.00	27.33>24	24	
		134/5670	43.16	27.35>24	24	
	802.11ac VHT80	106/5530	84.40	30.26>24	24	
	Note: 250mW=24dBm					



Note: Average Power with duty factor = Average Power Measured +Duty cycle correction factor

U-NII-1

Network Standards	Channel/ Frequency (MHz)	Average Power Measured (dBm)	Average Power with duty factor (dBm)	Limit (dBm)	Conclusion
802.11a	36/5180	12.65	13.25	24	PASS
	44/5220	12.72	13.32	24	PASS
	48/5240	12.44	13.04	24	PASS
802.11n HT20	36/5180	12.87	13.50	24	PASS
	44/5220	12.79	13.42	24	PASS
	48/5240	12.54	13.17	24	PASS
802.11n HT40	38/5190	11.74	13.21	24	PASS
	46/5230	11.64	13.11	24	PASS
802.11ac VHT20	36/5180	12.44	13.24	24	PASS
	44/5220	12.32	13.12	24	PASS
	48/5240	12.19	12.99	24	PASS
802.11ac VHT40	38/5190	11.58	13.05	24	PASS
	46/5230	11.69	13.16	24	PASS
802.11ac VHT80	42/5210	10.05	12.67	24	PASS

Note: 1. For Total Power, according to KDB 662911 D01 Multiple Transmitter Output v02r01 1),



U-NII-2A

Network Standards	Channel/ Frequency (MHz)	Average Power Measured (dBm)	Average Power with duty factor (dBm)	Limit (dBm)	Conclusion
802.11a	52/5260	12.47	13.07	24.00	PASS
	60/5300	12.53	13.13	24.00	PASS
	64/5320	12.36	12.96	24.00	PASS
802.11n HT20	52/5260	12.42	13.05	24.00	PASS
	60/5300	12.72	13.35	24.00	PASS
	64/5320	12.38	13.01	24.00	PASS
802.11n HT40	54/5270	11.77	13.24	24.00	PASS
	62/5310	11.69	13.16	24.00	PASS
802.11ac VHT20	52/5260	12.29	13.09	24.00	PASS
	60/5300	12.37	13.17	24.00	PASS
	64/5320	12.11	12.91	24.00	PASS
802.11ac VHT40	54/5270	11.53	13.00	24.00	PASS
	62/5310	11.65	13.12	24.00	PASS
802.11ac VHT80	58/5290	10.38	13.00	24.00	PASS

Note: Average Power with duty factor = Average Power Measured +Duty cycle correction factor



U-NII-2C

Network Standards	Channel/ Frequency (MHz)	Average Power Measured (dBm)	Average Power with duty factor (dBm)	Limit (dBm)	Conclusion
802.11a	100/5500	12.48	13.08	24.00	PASS
	116/5580	12.42	13.02	24.00	PASS
	140/5700	12.23	12.83	24.00	PASS
802.11n HT20	100/5500	12.42	13.05	24.00	PASS
	116/5580	12.36	12.99	24.00	PASS
	140/5700	12.28	12.91	24.00	PASS
802.11n HT40	102/5510	11.74	13.21	24.00	PASS
	110/5550	11.62	13.09	24.00	PASS
	134/5670	11.52	12.99	24.00	PASS
802.11ac VHT20	100/5500	12.53	13.33	24.00	PASS
	116/5580	12.47	13.27	24.00	PASS
	140/5700	12.25	13.05	24.00	PASS
802.11ac VHT40	102/5510	11.85	13.32	24.00	PASS
	110/5550	11.76	13.23	24.00	PASS
	134/5670	11.59	13.06	24.00	PASS
802.11ac VHT80	106/5530	10.31	12.93	24.00	PASS

Note: Average Power with duty factor = Average Power Measured +Duty cycle correction factor



U-NII-3

Network Standards	Channel/ Frequency (MHz)	Average Power Measured (dBm)	Average Power with duty factor (dBm)	Limit (dBm)	Conclusion
802.11a	149/5745	11.78	12.38	30	PASS
	157/5785	11.84	12.44	30	PASS
	165/5825	11.79	12.39	30	PASS
802.11n HT20	149/5745	11.44	12.07	30	PASS
	157/5785	11.57	12.20	30	PASS
	165/5825	11.64	12.27	30	PASS
802.11n HT40	151/5755	10.78	12.25	30	PASS
	159/5795	10.89	12.36	30	PASS
802.11ac VHT20	149/5745	11.58	12.38	30	PASS
	157/5785	11.66	12.46	30	PASS
	165/5825	11.38	12.18	30	PASS
802.11ac VHT40	151/5755	10.78	12.25	30	PASS
	159/5795	10.69	12.16	30	PASS
802.11ac VHT80	155/5775	9.43	12.05	30	PASS

Note: Average Power with duty factor = Average Power Measured +Duty cycle correction factor

5.2. Unwanted Emission

Ambient condition

Temperature	Relative humidity	Pressure
23°C ~25°C	45%~50%	101.5kPa

Method of Measurement

The test set-up was made in accordance to the general provisions of ANSI C63.10-2013. The Equipment Under Test (EUT) was set up on a non-conductive table in the semi-anechoic chamber. The test was performed at the distance of 3 m between the EUT and the receiving antenna. The radiated emissions measurements were made in a typical installation configuration. Sweep the whole frequency band range from 9kHz to the 10th harmonic of the carrier, and the emissions less than 20 dB below the permissible value are reported.

During the test, the height of receive antenna shall be moved from 1 to 4 meters, and the antenna shall be performed under horizontal and vertical polarization. The turntable shall be rotated from 0 to 360 degrees for detecting the maximum of radiated spurious signal level. The measurements shall be repeated with orthogonal polarization of the test antenna. The data of cable loss and antenna factor has been calibrated in full testing frequency range before the testing.

Set the spectrum analyzer in the following:

Below 1GHz (detector: Peak and Quasi-Peak)

RBW=100kHz / VBW=300kHz / Sweep=AUTO

Above 1GHz (detector: Peak):

I) Peak emission levels are measured by setting the instrument as follows:

- 1) RBW = 1 MHz.
- 2) VBW \geq [3 × RBW]
- 3) Detector = peak.
- 4) Sweep time = auto.
- 5) Trace mode = max hold.
- 6) Allow sweeps to continue until the trace stabilizes. Note that if the transmission is not continuous, then the time required for the trace to stabilize will increase by a factor of approximately 1 / D, where D is the duty cycle.

II) Average emission levels are measured by setting the instrument as follows:

- a) RBW = 1 MHz.
- b) VBW \geq [3 × RBW].
- c) Detector = RMS (power averaging), if $[\text{span} / (\# \text{ of points in sweep})] \text{RBW} > 2$. Satisfying this condition can require increasing the number of points in the sweep or reducing the span. If the condition is not satisfied, then the detector mode shall be set to peak.
- d) Averaging type = power (i.e., rms) (As an alternative, the detector and averaging type may be set for linear voltage averaging. Some instruments require linear display mode to use linear voltage averaging. Log or dB averaging shall not be used.)



e) Sweep time = auto.

f) Perform a trace average of at least 100 traces if the transmission is continuous. If the transmission is not continuous, then the number of traces shall be increased by a factor of $1 / D$, where D is the duty cycle. For example, with 50% duty cycle, at least 200 traces shall be averaged. (If a specific emission is demonstrated to be continuous—i.e., 100% duty cycle—then rather than turning ON and OFF with the transmit cycle, at least 100 traces shall be averaged.)

g) If tests are performed with the EUT transmitting at a duty cycle less than 98%, then a correction factor shall be added to the measurement results prior to comparing with the emission limit, to compute the emission level that would have been measured had the test been performed at 100% duty cycle. The correction factor is computed as follows:

1) If power averaging (rms) mode was used in the preceding step e), then the correction factor is $[10 \log (1 / D)]$, where D is the duty cycle. For example, if the transmit duty cycle was 50%, then 3 dB shall be added to the measured emission levels.

2) If linear voltage averaging mode was used in the preceding step e), then the correction factor is $[20 \log (1 / D)]$, where D is the duty cycle. For example, if the transmit duty cycle was 50%, then 6 dB shall be added to the measured emission levels.

3) If a specific emission is demonstrated to be continuous (100% duty cycle) rather than turning ON and OFF with the transmit cycle, then no duty cycle correction is required for that emission.

Reduce the video bandwidth until no significant variations in the displayed signal are observed in subsequent traces, provided the video bandwidth is no less than 1 Hz. For regulatory requirements that specify averaging only over the transmit duration (e.g., digital transmission system [DTS] and Unlicensed National Information Infrastructure [U-NII]), the video bandwidth shall be greater than $[1 / (\text{minimum transmitter on time})]$ and no less than 1 Hz.

The field strength of spurious emission was measured in the following position: EUT stand-up position (Z axis), lie-down position (X, Y axis). The worst emission was found in stand-up position (Z axis) and the loop antenna is vertical, others antenna are vertical and horizontal.

The test is in transmitting mode.

9KHz~~~30MHz

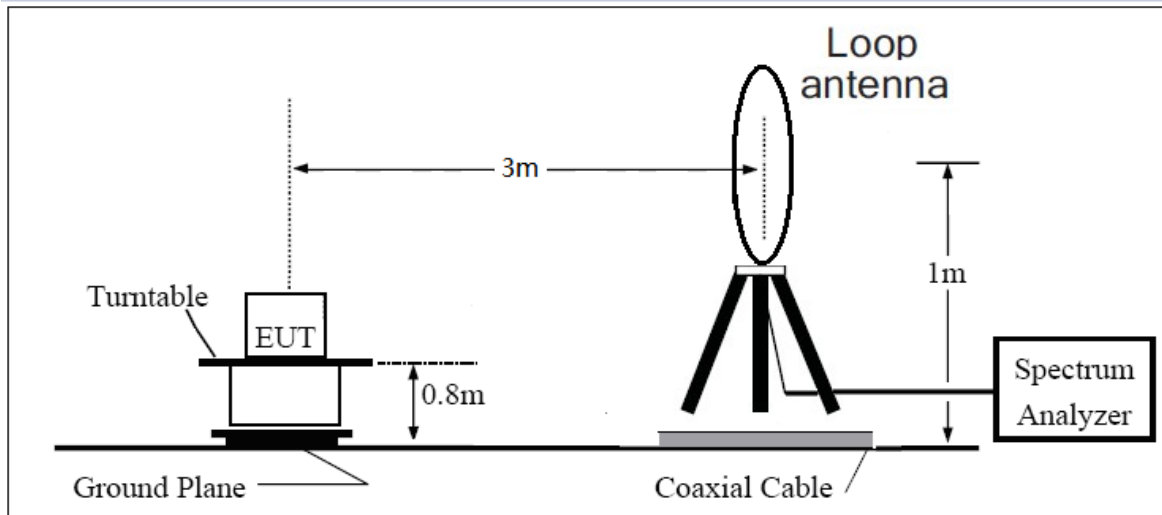

30MHz~~~ 1GHz

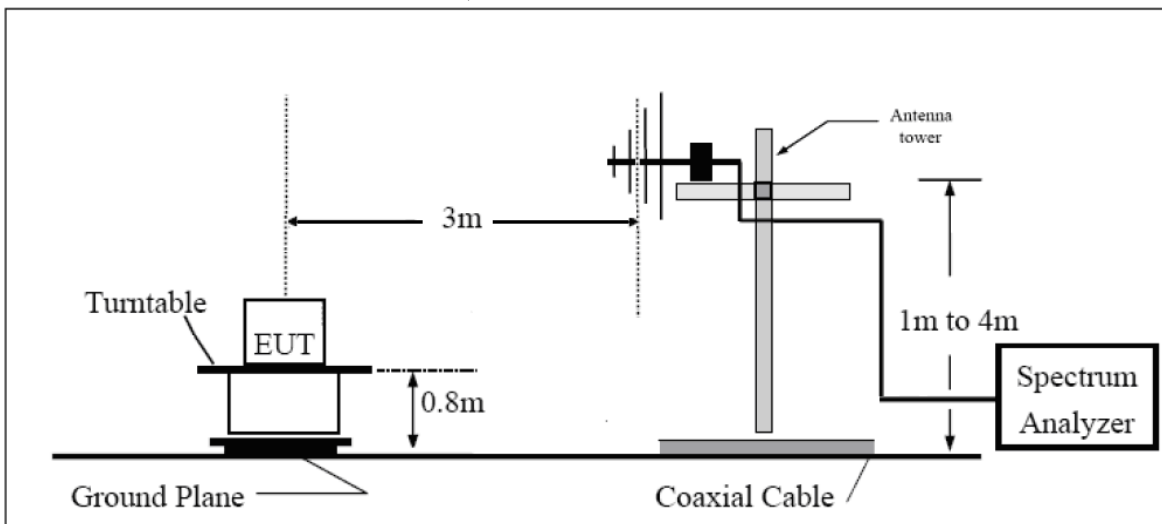

Above 1GHz

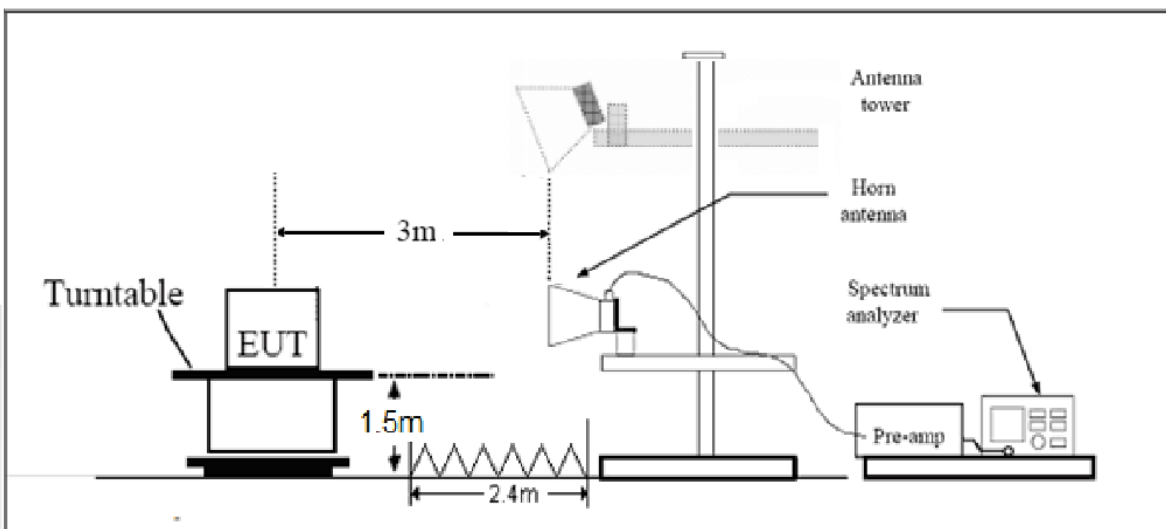

Note: Area side:2.4mX3.6m

Limits

- (1) For transmitters operating in the 5725-5850 MHz band: All emissions shall be limited to a level of -27 dBm/MHz at 75 MHz or more above or below the band edge increasing linearly to 10 dBm/MHz at 25 MHz above or below the band edge, and from 25 MHz above or below the band edge increasing linearly to a level of 15.6 dBm/MHz at 5 MHz above or below the band edge, and from 5 MHz above or below the band edge increasing linearly to a level of 27 dBm/MHz at the band edge.
- (2) For transmitters operating in the 5.15-5.25 GHz band: All emissions outside of the 5.15-5.35 GHz band shall not exceed an e.i.r.p. of -27 dBm/MHz(68.2dBμV/m).
- (3) For transmitters operating in the 5.25-5.35 GHz band: All emissions outside of the 5.15-5.35 GHz band shall not exceed an e.i.r.p. of -27 dBm/MHz(68.2dBμV/m).
- (4) For transmitters operating in the 5.47-5.725 GHz band: All emissions outside of the 5.47-5.725 GHz band shall not exceed an e.i.r.p. of -27 dBm/MHz(68.2dBμV/m).

Note: the following formula is used to convert the EIRP to field strength

§1、 $E[\text{dB}\mu\text{V}/\text{m}] = \text{EIRP}[\text{dBm}] - 20 \log(d[\text{meters}]) + 104.77$, where E = field strength and

d = distance at which field strength limit is specified in the rules;

§2、 $E[\text{dB}\mu\text{V}/\text{m}] = \text{EIRP}[\text{dBm}] + 95.2$, for d = 3 meters

- (5) Unwanted spurious emissions fallen in restricted bands per FCC Part15.205 shall comply with the general field strength limits set forth in § 15.209 as below table.

Frequency of emission (MHz)	Field strength(uV/m)	Field strength(dBuV/m)
0.009–0.490	2400/F(kHz)	/
0.490–1.705	24000/F(kHz)	/
1.705–30.0	30	/
30-88	100	40
88-216	150	43.5
216-960	200	46
Above960	500	54



MHz	MHz	MHz	GHz
0.090 - 0.110	16.42 - 16.423	399.9 - 410	4.5 - 5.15
0.495 - 0.505	16.69475 - 16.69525	608 - 614	5.35 - 5.46
2.1735 - 2.1905	16.80425 - 16.80475	960 - 1240	7.25 - 7.75
4.125 - 4.128	25.5 - 25.67	1300 - 1427	8.025 - 8.5
4.17725 - 4.17775	37.5 - 38.25	1435 - 1626.5	9.0 - 9.2
4.20725 - 4.20775	73 - 74.6	1645.5 - 1646.5	9.3 - 9.5
6.215 - 6.218	74.8 - 75.2	1660 - 1710	10.6 - 12.7
6.26775 - 6.26825	108 - 121.94	1718.8 - 1722.2	13.25 - 13.4
6.31175 - 6.31225	123 - 138	2200 - 2300	14.47 - 14.5
8.291 - 8.294	149.9 - 150.05	2310 - 2390	15.35 - 16.2
8.362 - 8.366	156.52475 - 156.52525	2483.5 - 2500	17.7 - 21.4
8.37625 - 8.38675	156.7 - 156.9	2690 - 2900	22.01 - 23.12
8.41425 - 8.41475	162.0125 - 167.17	3260 - 3267	23.6 - 24.0
12.29 - 12.293	167.72 - 173.2	3332 - 3339	31.2 - 31.8
12.51975 - 12.52025	240 - 285	3345.8 - 3358	36.43 - 36.5
12.57675 - 12.57725	322 - 335.4	3600 - 4400	(²)
13.36 - 13.41			

Measurement Uncertainty

The assessed measurement uncertainty to ensure 95% confidence level for the normal distribution is with the coverage factor $k = 1.96$.

Frequency	Uncertainty
30MHz-200MHz	4.02 dB
200MHz-1GHz	3.28 dB
1GHz-18G	3.70 dB



Test Results:

The modulation and bandwidth are similar for 802.11n mode for 20MHz/40MHz and 802.11ac mode for V20MHz/V40MHz, therefore investigated worst case to representative mode in test report.

The signal beyond the limit is carrier.

U-NII-1

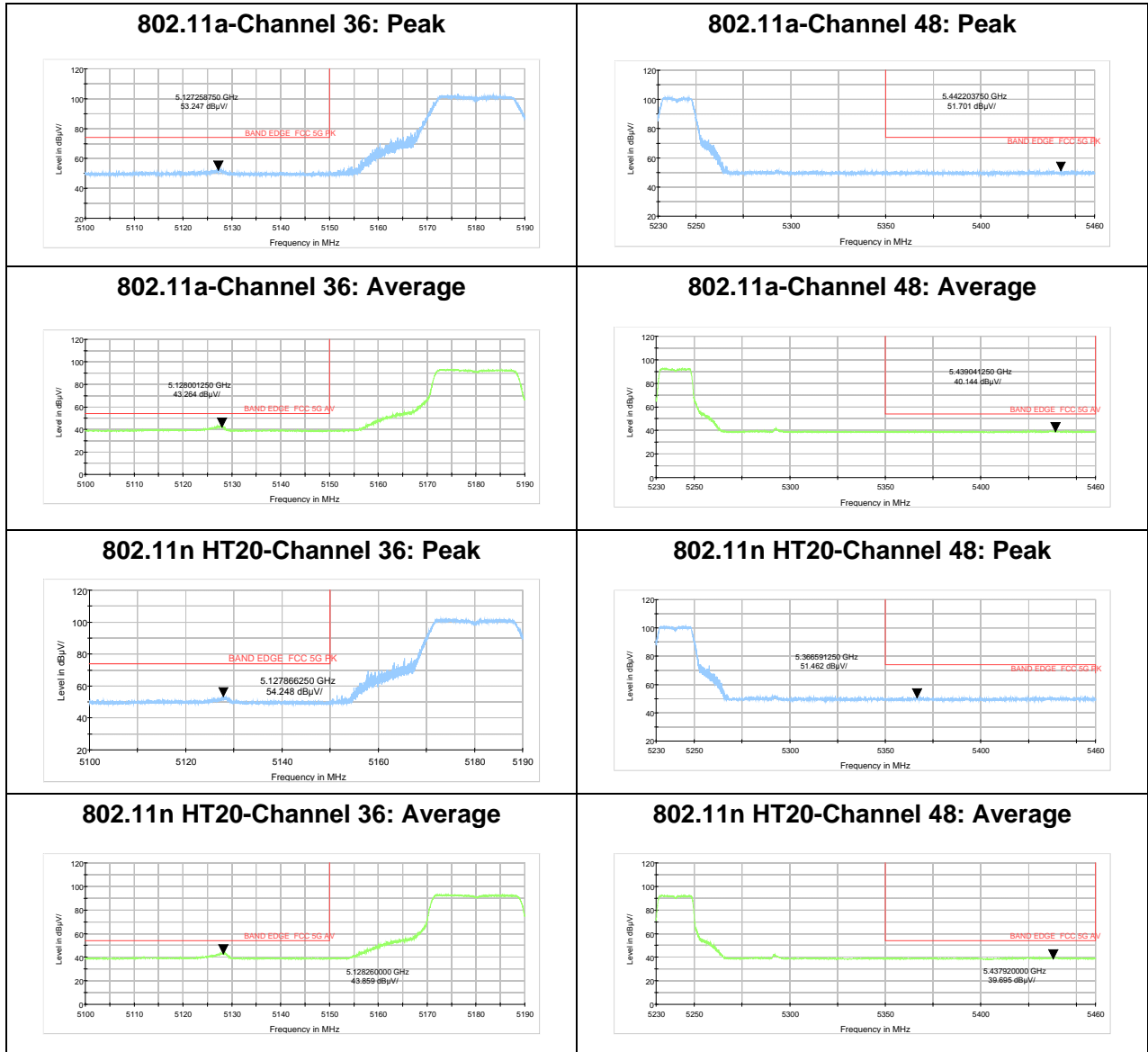

802.11n HT40-Channel 38: Peak

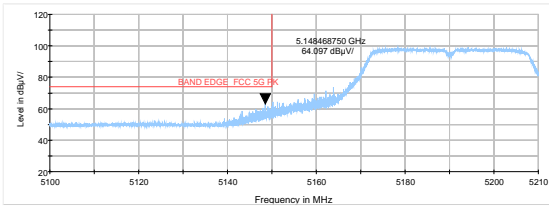

802.11n HT40-Channel 46: Peak

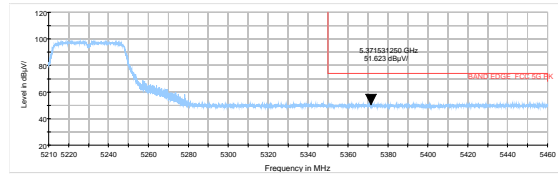

802.11n HT40-Channel 38: Average

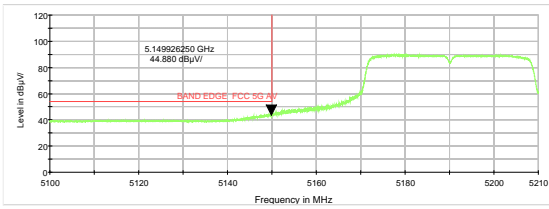

802.11n HT40-Channel 46: Average

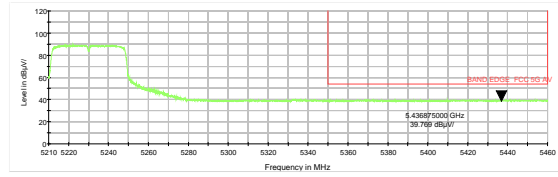

802.11ac VHT80 -Channel 42: Peak

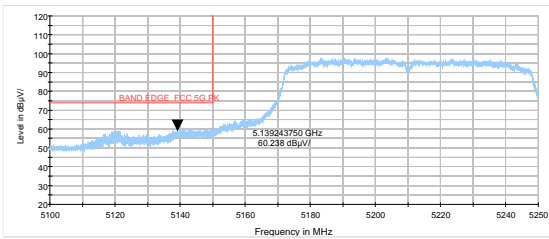

802.11ac VHT80- Channel 42: Average

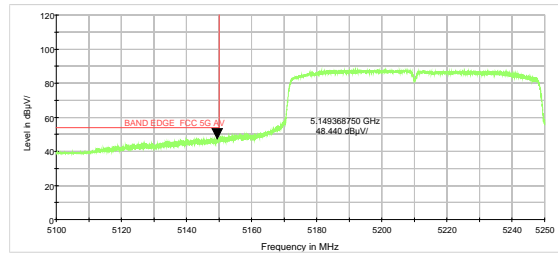



U-NII-2A

802.11a-Channel 52: Peak

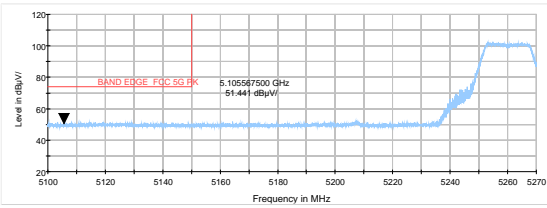

802.11a-Channel 64: Peak

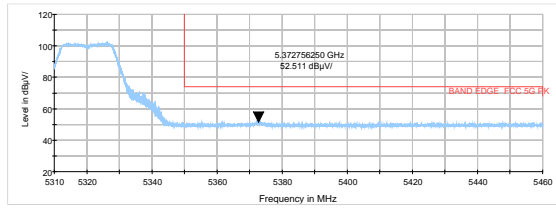

802.11a-Channel 52: Average

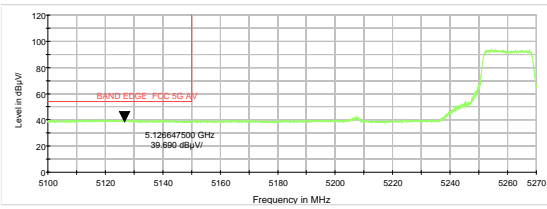

802.11a-Channel 64: Average

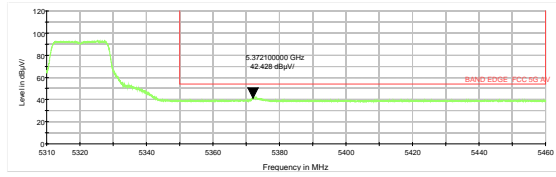

802.11n HT20-Channel 52: Peak

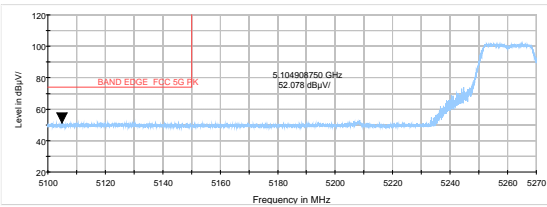

802.11n HT20-Channel 64: Peak

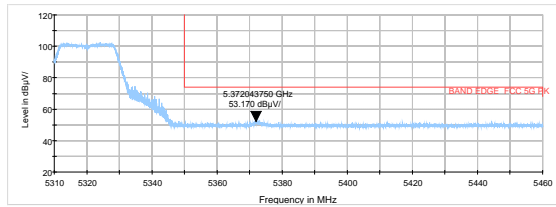

802.11n HT20-Channel 52: Average

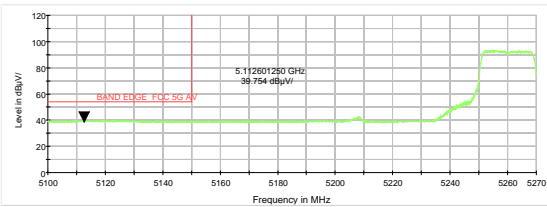

802.11n HT20-Channel 64: Average

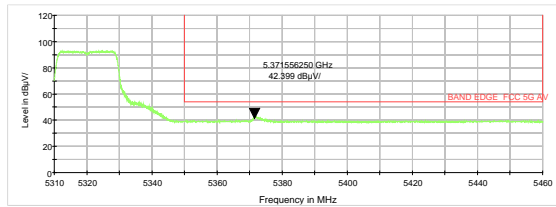



802.11n HT40-Channel 54: Peak

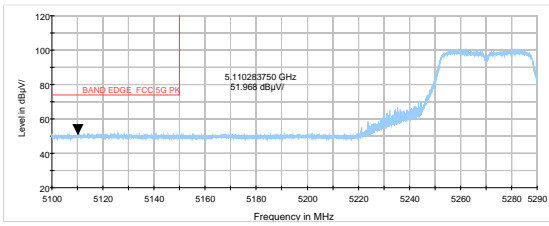

802.11n HT40-Channel 62: Peak

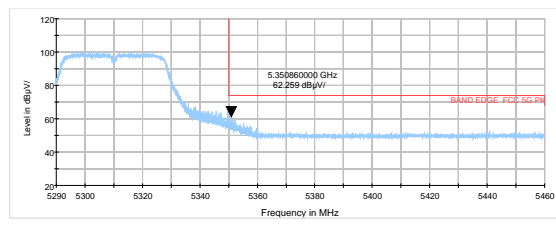

802.11n HT40-Channel 54: Average

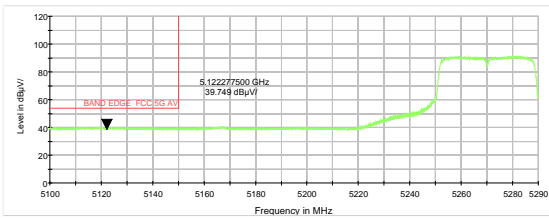

802.11n HT40-Channel 62: Average

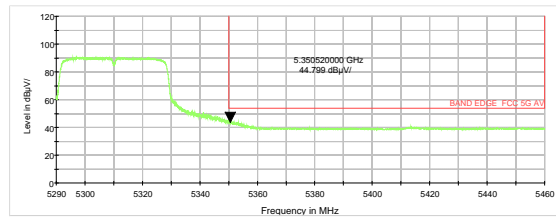

802.11ac VHT80 -Channel 58: Peak

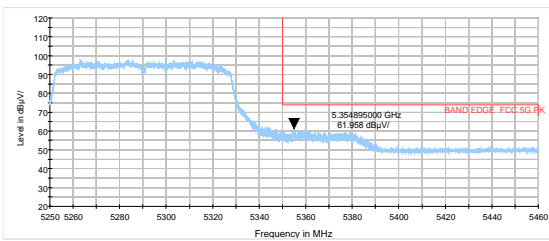

802.11ac VHT80- Channel 58: Average

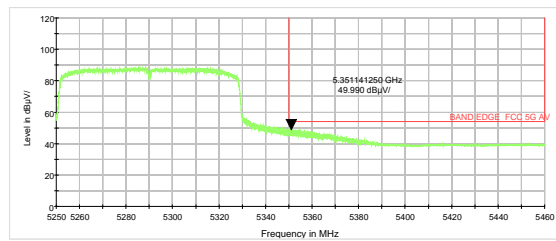



U-NII-2C

802.11a-Channel 100: Peak

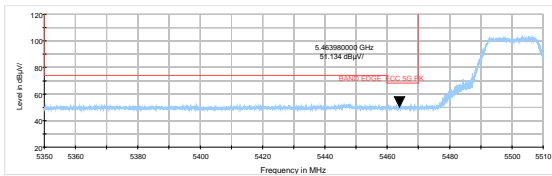

802.11n HT20-Channel 100: Peak

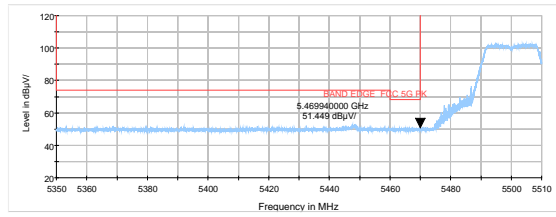

802.11a-Channel 100: Average

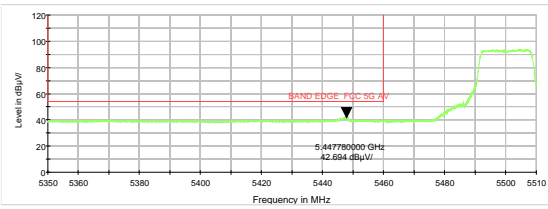

802.11n HT20-Channel 100: Average

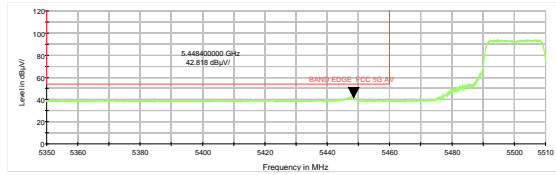

802.11a-Channel 140: Peak

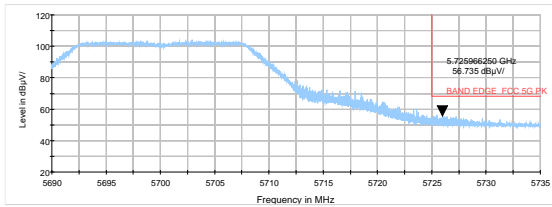

802.11n HT20-Channel 140: Peak

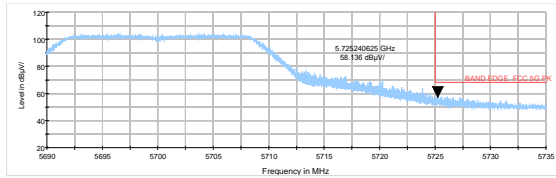



802.11n HT40-Channel 102: Peak

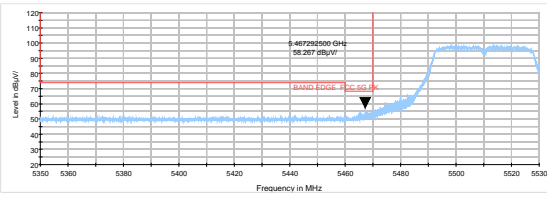

802.11ac VHT80 -Channel 106: Peak

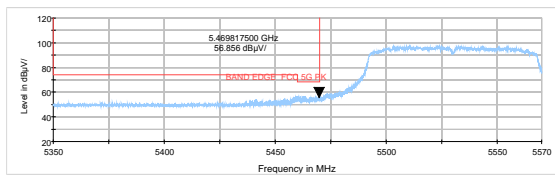

802.11n HT40-Channel 102: Average

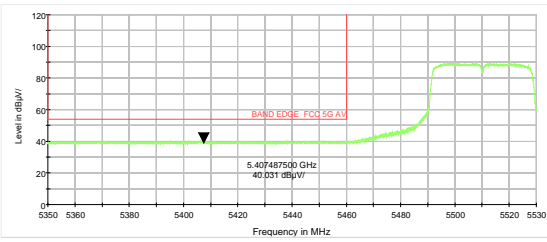

802.11ac VHT80- Channel 106: Average

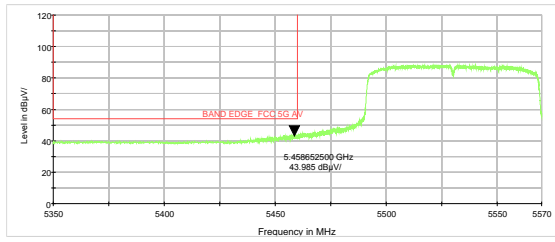

802.11n HT40-Channel 134: Peak

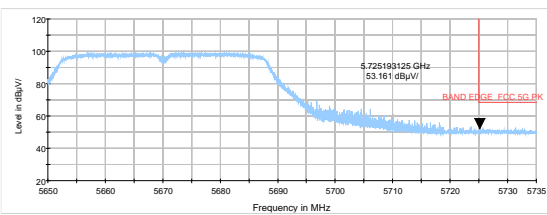



U-NII-3

802.11a-Channel 149: Peak

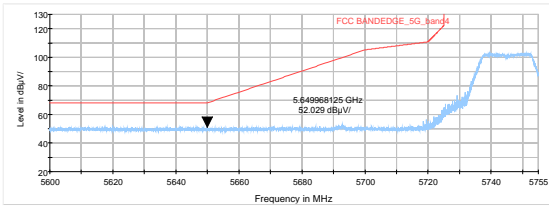

802.11a-Channel 165: Peak

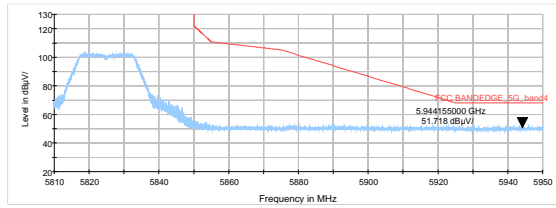

802.11n HT20-Channel 149: Peak

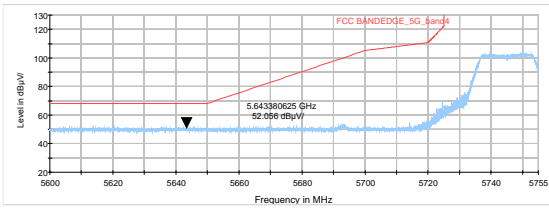

802.11n HT20-Channel 165: Peak

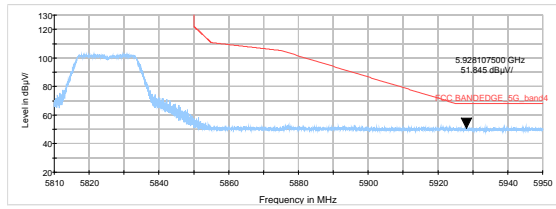

802.11n HT40-Channel 151: Peak

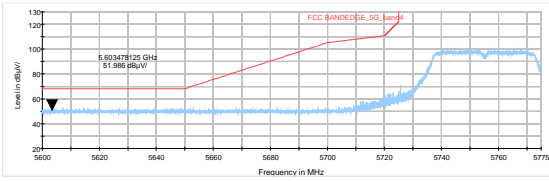

802.11n HT40-Channel 159: Peak

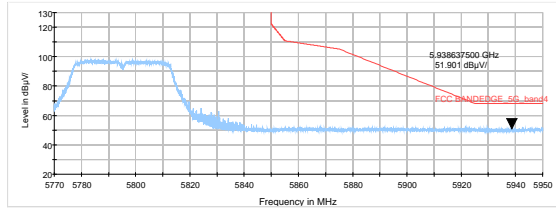

802.11ac VHT80- Channel 155: Peak

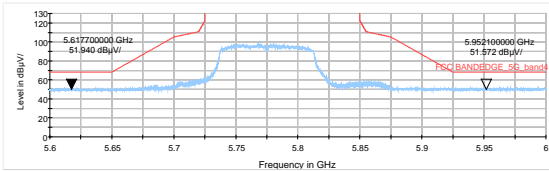

Result of RE

Test result

Sweep the whole frequency band through the range from 9kHz to the 10th harmonic of the carrier, the Emissions in the frequency band 30MHz-1GHz and 1GHz-18GHz are more than 20dB below the limit are not reported.

During the test, the Radiates Emission from 30MHz to 1GHz was performed in all modes with all channels, 802.11a CH116 are selected as the worst condition. The test data of the worst-case condition was recorded in this report.

Continuous TX mode:

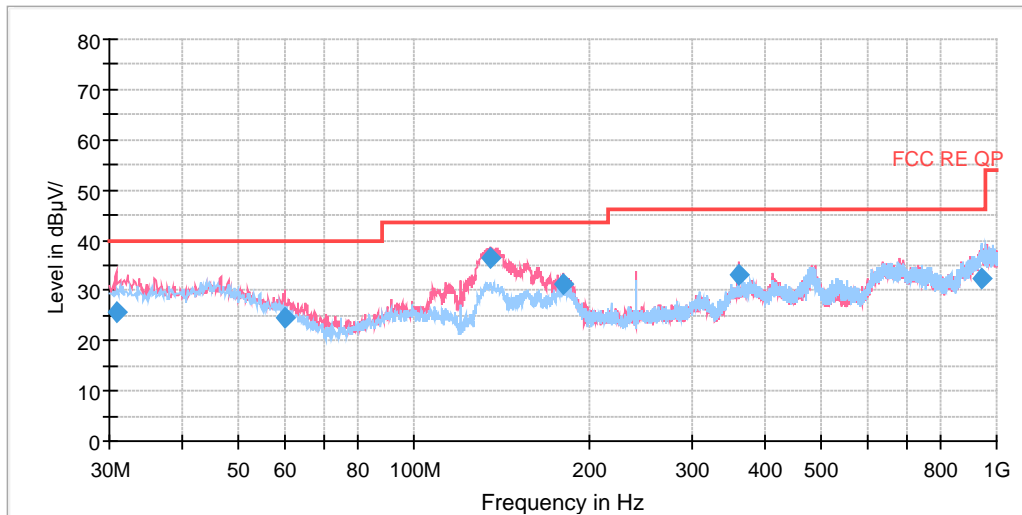

Radiates Emission from 30MHz to 1GHz

Frequency (MHz)	Quasi-Peak (dBuV/m)	Height (cm)	Polarization	Azimuth (deg)	Correct Factor (dB)	Margin (dB)	Limit (dBuV/m)
30.925872	25.50	100.0	V	101.0	3.9	14.50	40.00
59.998878	24.66	100.0	V	0.0	-1.8	15.34	40.00
134.784047	36.31	100.0	V	154.0	-6.9	7.19	43.50
180.016285	31.28	100.0	V	257.0	-7.2	12.22	43.50
360.022500	33.07	100.0	V	48.0	1.5	12.93	46.00
940.798000	32.51	184.0	H	220.0	9.0	13.49	46.00

**Remark: 1. Correction Factor = Antenna factor+ Insertion loss(cable loss+amplifier gain)
 2. Margin = Limit – Quasi-Peak**

802.11a CH36

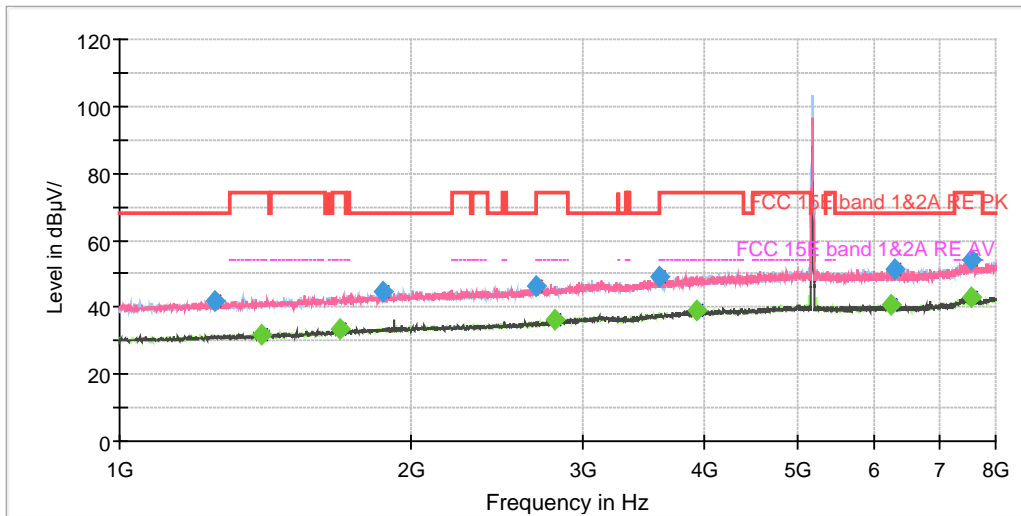

Note: The signal beyond the limit is carrier.
Radiates Emission from 1GHz to 8GHz

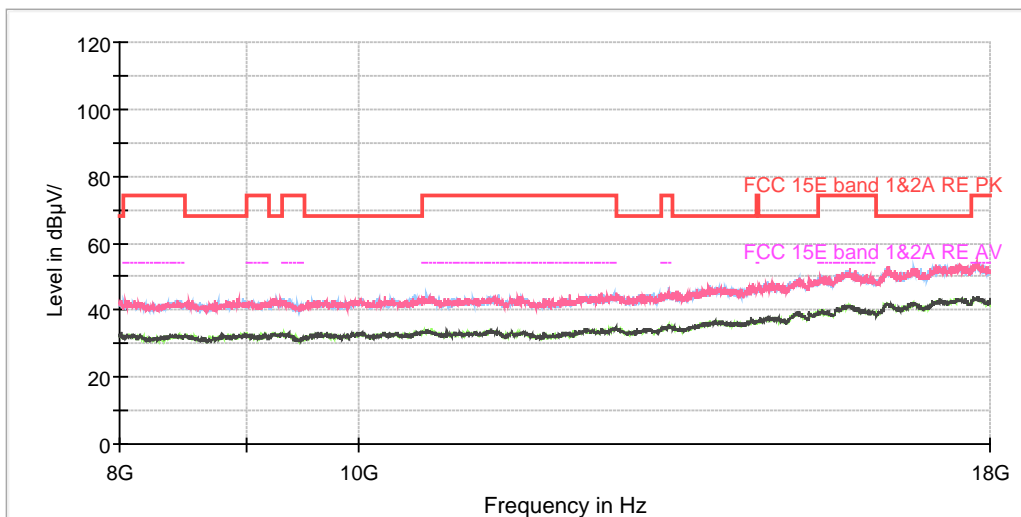

Radiates Emission from 8GHz to 18GHz



Frequency (MHz)	MaxPeak (dB μ V/m)	Average (dB μ V/m)	Height (cm)	Pol	Azimuth (deg)	Corr. (dB/m)	Margin (dB)	Limit (dB μ V/m)
1252.875000	41.58	---	100.0	V	268.0	-7.3	26.62	68.20
1400.750000	---	32.08	100.0	V	84.0	-6.5	21.92	54.00
1690.375000	---	33.29	200.0	H	52.0	-4.9	20.71	54.00
1865.375000	44.57	---	200.0	V	139.0	-3.9	23.63	68.20
2689.625000	46.13	---	200.0	V	219.0	-0.4	22.07	68.20
2807.750000	---	36.29	200.0	V	241.0	0.2	17.71	54.00
3599.625000	48.98	---	100.0	V	351.0	3.3	19.22	68.20
3932.125000	---	39.10	200.0	H	27.0	4.3	14.90	54.00
6250.875000	---	40.65	100.0	H	185.0	8.5	13.35	54.00
6301.625000	51.55	---	100.0	V	74.0	8.5	16.65	68.20
7548.500000	53.96	---	100.0	H	304.0	10.3	20.04	74.00
7568.625000	---	42.72	200.0	V	344.0	10.3	11.28	54.00

Remark: 1. Correction Factor = Antenna factor+ Insertion loss (cable loss + amplifier gain)

802.11a CH44

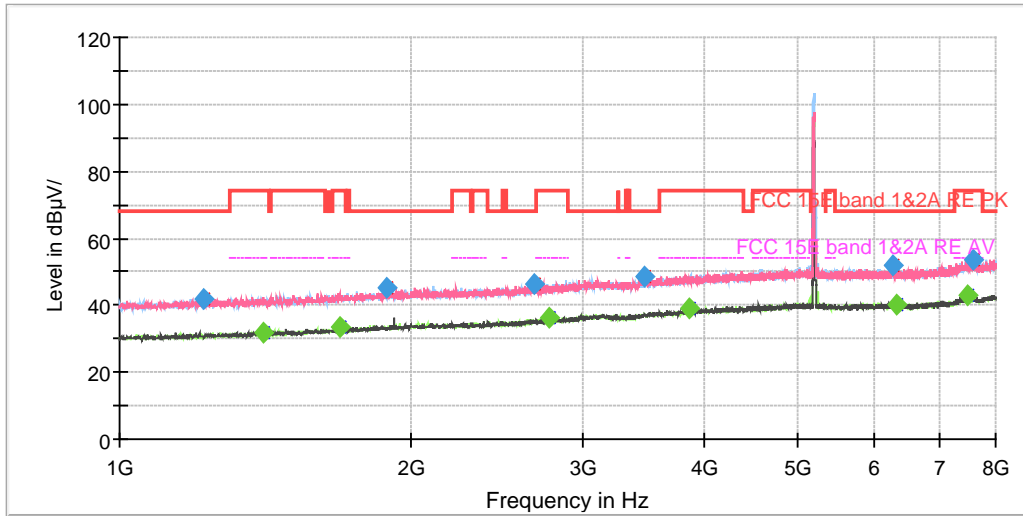

Note: The signal beyond the limit is carrier.
Radiates Emission from 1GHz to 8GHz

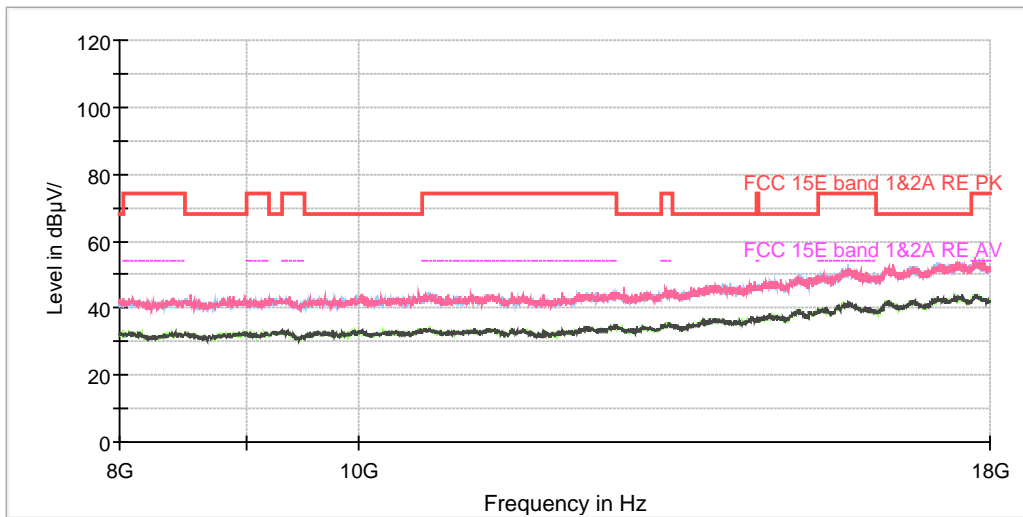

Radiates Emission from 8GHz to 18GHz



Frequency (MHz)	MaxPeak (dB μ V/m)	Average (dB μ V/m)	Height (cm)	Pol	Azimuth (deg)	Corr. (dB/m)	Margin (dB)	Limit (dB μ V/m)
1219.625000	42.07	---	100.0	H	122.0	-7.5	26.13	68.20
1409.500000	---	31.89	100.0	V	33.0	-6.4	22.11	54.00
1688.625000	---	33.48	200.0	V	136.0	-4.9	20.52	54.00
1888.125000	45.39	---	100.0	V	22.0	-3.8	22.81	68.20
2673.875000	46.07	---	200.0	V	0.0	-0.5	22.13	68.20
2769.250000	---	36.07	100.0	V	185.0	0.0	17.93	54.00
3479.750000	48.35	---	200.0	V	267.0	2.6	19.85	68.20
3869.125000	---	38.82	100.0	V	202.0	4.0	15.18	54.00
6258.750000	51.63	---	100.0	H	108.0	8.5	16.57	68.20
6335.750000	---	40.43	100.0	V	44.0	8.5	13.57	54.00
7482.875000	---	42.75	100.0	V	29.0	10.2	11.25	54.00
7582.625000	53.73	---	100.0	H	357.0	10.3	20.27	74.00

Remark: 1. Correction Factor = Antenna factor+ Insertion loss (cable loss + amplifier gain)



802.11a CH48

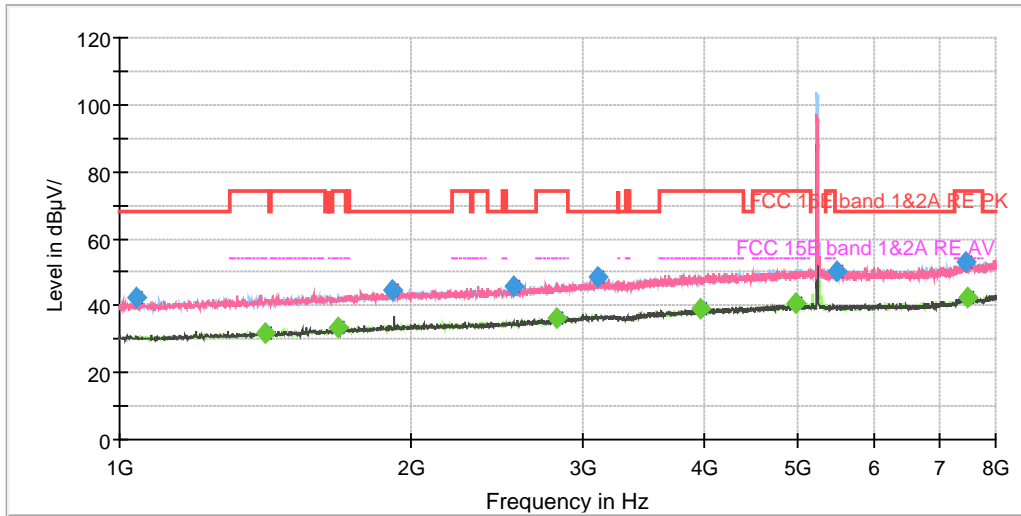

Note: The signal beyond the limit is carrier.
Radiates Emission from 1GHz to 8GHz

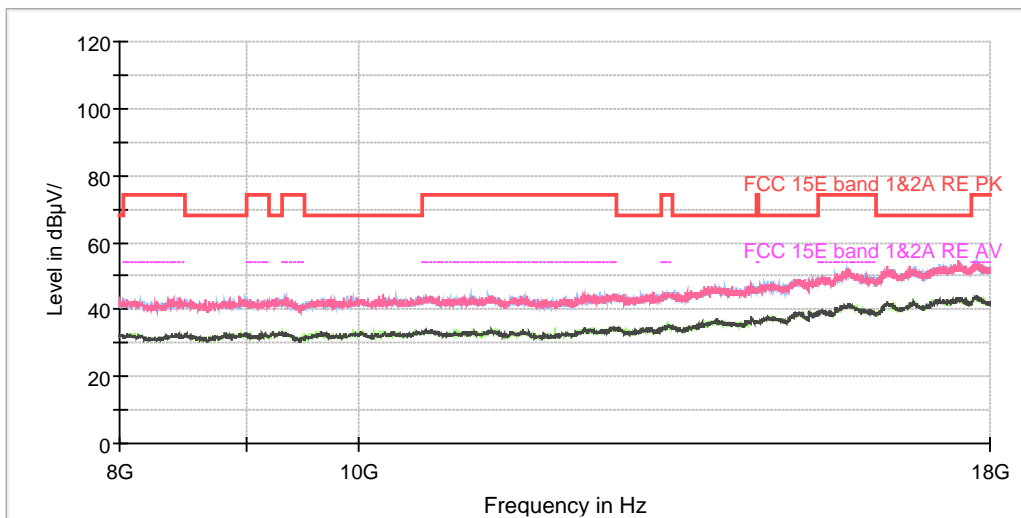

Radiates Emission from 8GHz to 18GHz



Frequency (MHz)	MaxPeak (dB μ V/m)	Average (dB μ V/m)	Height (cm)	Pol	Azimuth (deg)	Corr. (dB/m)	Margin (dB)	Limit (dB μ V/m)
1039.375000	42.21	---	200.0	V	62.0	-8.4	25.99	68.20
1413.875000	---	32.00	100.0	H	223.0	-6.4	22.00	54.00
1683.375000	---	33.43	100.0	V	80.0	-4.9	20.57	54.00
1914.375000	44.75	---	200.0	V	226.0	-3.6	23.45	68.20
2543.500000	45.84	---	200.0	H	154.0	-1.1	22.36	68.20
2820.000000	---	36.22	200.0	V	348.0	0.3	17.78	54.00
3109.625000	48.46	---	100.0	H	173.0	1.8	19.74	68.20
3968.875000	---	38.83	200.0	H	7.0	4.3	15.17	54.00
4976.875000	---	40.63	200.0	V	323.0	6.6	13.37	54.00
5500.125000	50.49	---	100.0	H	348.0	7.3	17.71	68.20
7464.500000	53.08	---	100.0	V	188.0	10.1	20.92	74.00
7489.000000	---	42.56	100.0	H	290.0	10.2	11.44	54.00

Remark: 1. Correction Factor = Antenna factor+ Insertion loss (cable loss + amplifier gain)

802.11a CH52

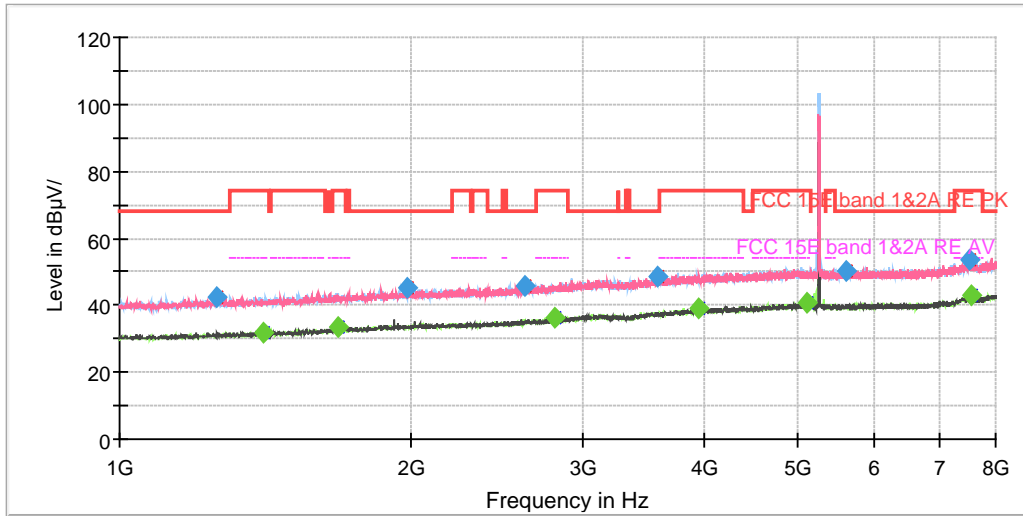

Note: The signal beyond the limit is carrier.
Radiates Emission from 1GHz to 8GHz

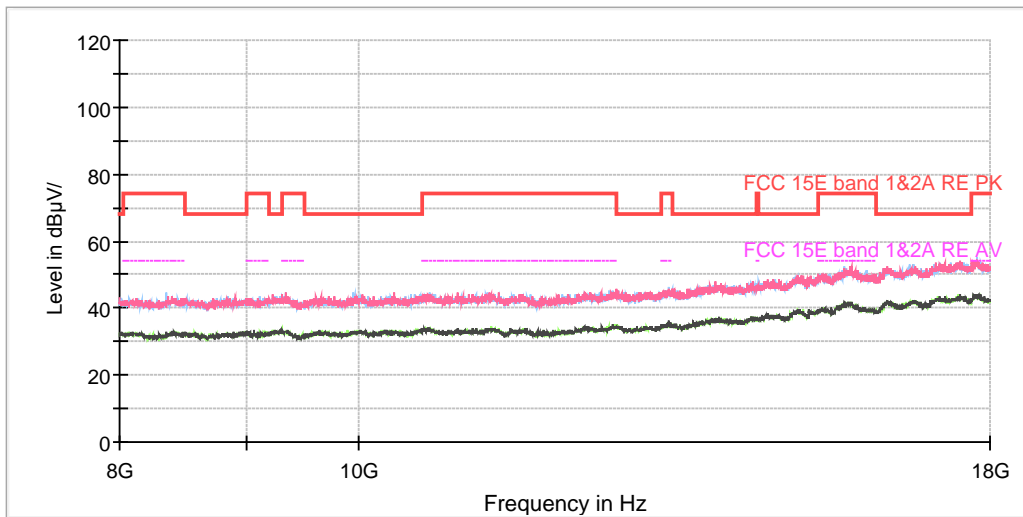

Radiates Emission from 8GHz to 18GHz



Frequency (MHz)	MaxPeak (dB μ V/m)	Average (dB μ V/m)	Height (cm)	Pol	Azimuth (deg)	Corr. (dB/m)	Margin (dB)	Limit (dB μ V/m)
1260.750000	42.35	---	100.0	H	28.0	-7.3	25.85	68.20
1405.125000	---	32.08	200.0	H	0.0	-6.4	21.92	54.00
1682.500000	---	33.49	100.0	V	44.0	-4.9	20.51	54.00
1981.750000	45.14	---	200.0	V	102.0	-3.3	23.06	68.20
2617.000000	46.01	---	200.0	V	216.0	-0.8	22.19	68.20
2813.875000	---	36.15	200.0	V	128.0	0.2	17.85	54.00
3581.250000	48.29	---	200.0	V	244.0	3.2	19.91	68.20
3957.500000	---	39.13	200.0	V	192.0	4.3	14.87	54.00
5111.625000	---	40.55	100.0	H	34.0	6.9	13.45	54.00
5606.875000	50.13	---	200.0	H	293.0	7.5	18.07	68.20
7524.000000	53.50	---	100.0	V	258.0	10.2	20.50	74.00
7559.000000	---	42.81	100.0	H	143.0	10.3	11.19	54.00

Remark: 1. Correction Factor = Antenna factor+ Insertion loss (cable loss + amplifier gain)

802.11a CH60

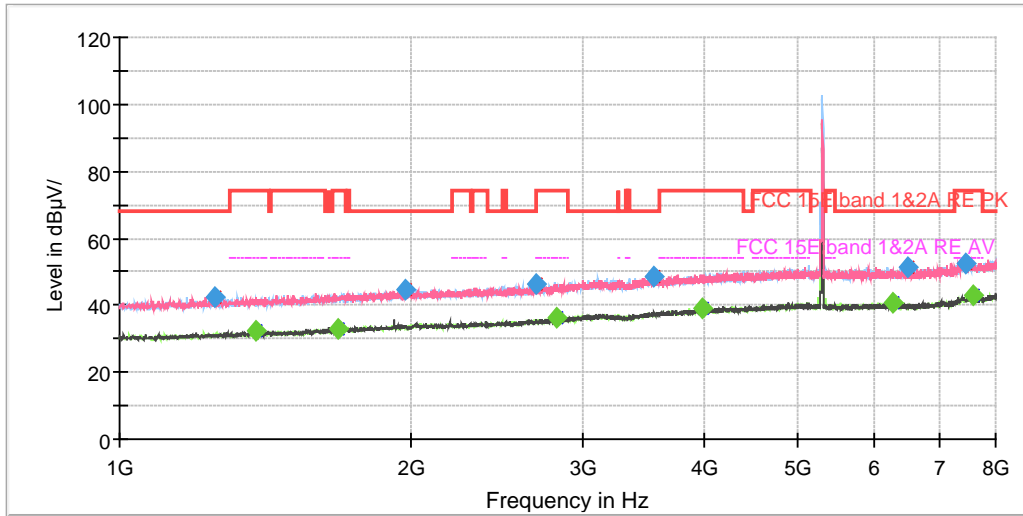

Note: The signal beyond the limit is carrier.
Radiates Emission from 1GHz to 8GHz

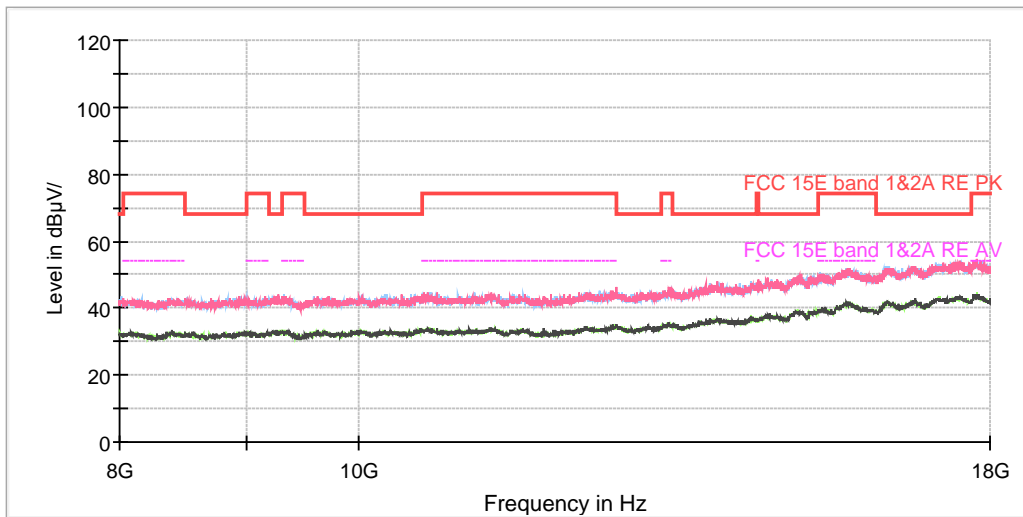

Radiates Emission from 8GHz to 18GHz



Frequency (MHz)	MaxPeak (dB μ V/m)	Average (dB μ V/m)	Height (cm)	Pol	Azimuth (deg)	Corr. (dB/m)	Margin (dB)	Limit (dB μ V/m)
1255.500000	42.54	---	100.0	H	210.0	-7.3	25.66	68.20
1381.500000	---	32.22	200.0	V	318.0	-6.6	21.78	54.00
1679.875000	---	33.19	100.0	V	1.0	-4.9	20.81	54.00
1968.625000	44.68	---	100.0	V	136.0	-3.4	23.52	68.20
2682.625000	46.17	---	100.0	V	33.0	-0.5	22.03	68.20
2825.250000	---	36.03	100.0	H	267.0	0.3	17.97	54.00
3560.250000	48.46	---	200.0	V	3.0	3.1	19.74	68.20
3984.625000	---	39.05	100.0	V	14.0	4.3	14.95	54.00
6255.250000	---	40.74	100.0	V	97.0	8.5	13.26	54.00
6481.000000	51.24	---	100.0	V	115.0	8.6	16.96	68.20
7459.250000	52.74	---	100.0	H	295.0	10.1	21.26	74.00
7574.750000	---	42.74	100.0	V	73.0	10.3	11.26	54.00

Remark: 1. Correction Factor = Antenna factor+ Insertion loss (cable loss + amplifier gain)

802.11a CH64

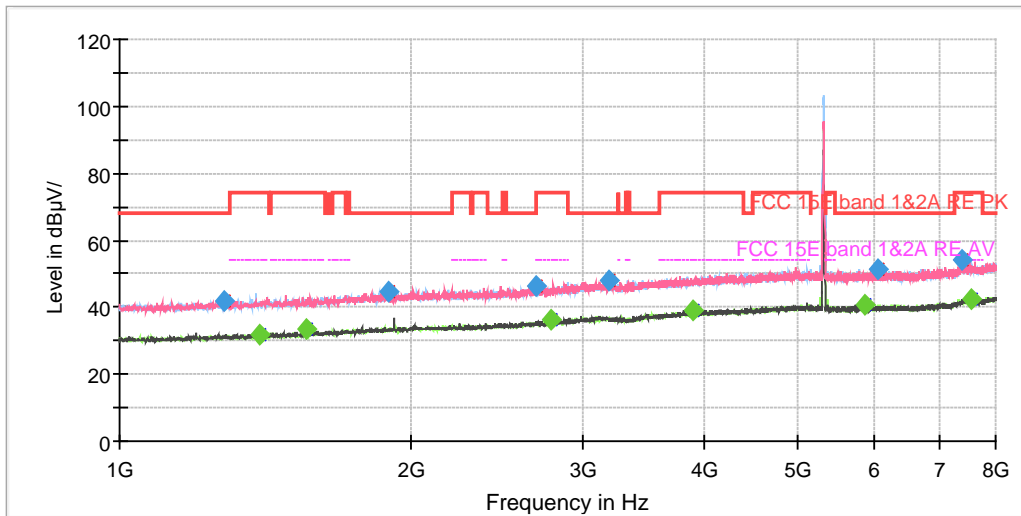

Note: The signal beyond the limit is carrier.
Radiates Emission from 1GHz to 8GHz

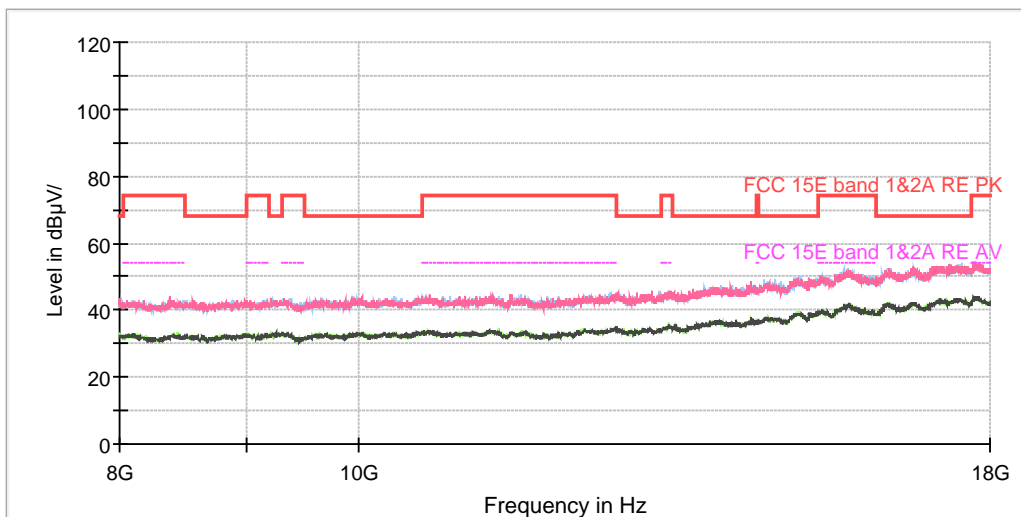

Radiates Emission from 8GHz to 18GHz



Frequency (MHz)	MaxPeak (dB μ V/m)	Average (dB μ V/m)	Height (cm)	Pol	Azimuth (deg)	Corr. (dB/m)	Margin (dB)	Limit (dB μ V/m)
1281.750000	41.74	---	200.0	H	15.0	-7.1	26.46	68.20
1394.625000	---	31.89	100.0	V	143.0	-6.5	22.11	54.00
1560.000000	---	33.31	100.0	V	160.0	-5.6	20.69	54.00
1896.000000	44.69	---	100.0	V	0.0	-3.7	23.51	68.20
2687.000000	46.18	---	200.0	V	220.0	-0.5	22.02	68.20
2786.750000	---	36.24	200.0	V	278.0	0.1	17.76	54.00
3200.625000	48.14	---	200.0	V	321.0	1.9	20.06	68.20
3909.375000	---	39.07	100.0	H	307.0	4.1	14.93	54.00
5861.500000	---	40.73	200.0	V	93.0	7.9	13.27	54.00
6040.000000	51.16	---	100.0	H	244.0	8.2	17.04	68.20
7396.250000	54.23	---	200.0	V	292.0	10.0	19.77	74.00
7567.750000	---	42.65	200.0	V	188.0	10.3	11.35	54.00

Remark: 1. Correction Factor = Antenna factor+ Insertion loss (cable loss + amplifier gain)

802.11a CH100

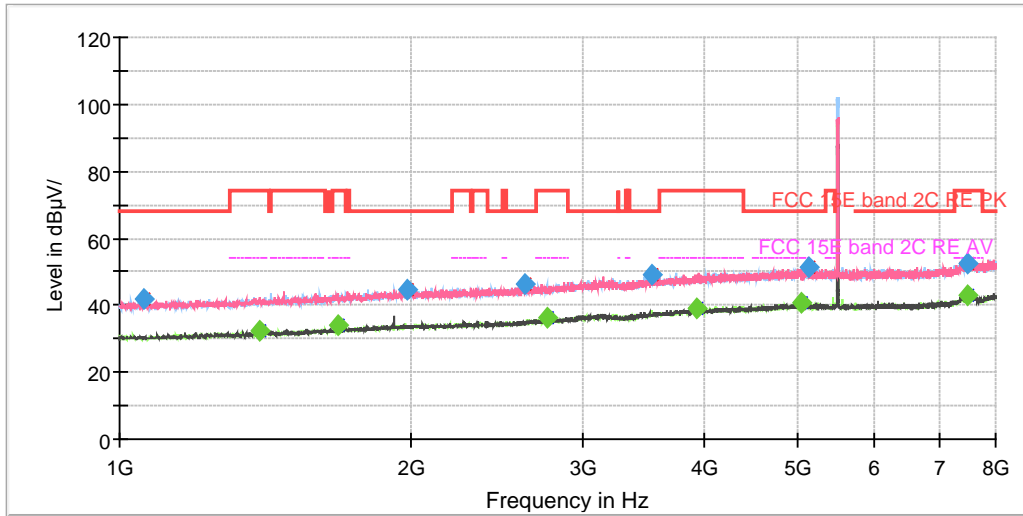

Note: The signal beyond the limit is carrier.
Radiates Emission from 1GHz to 8GHz

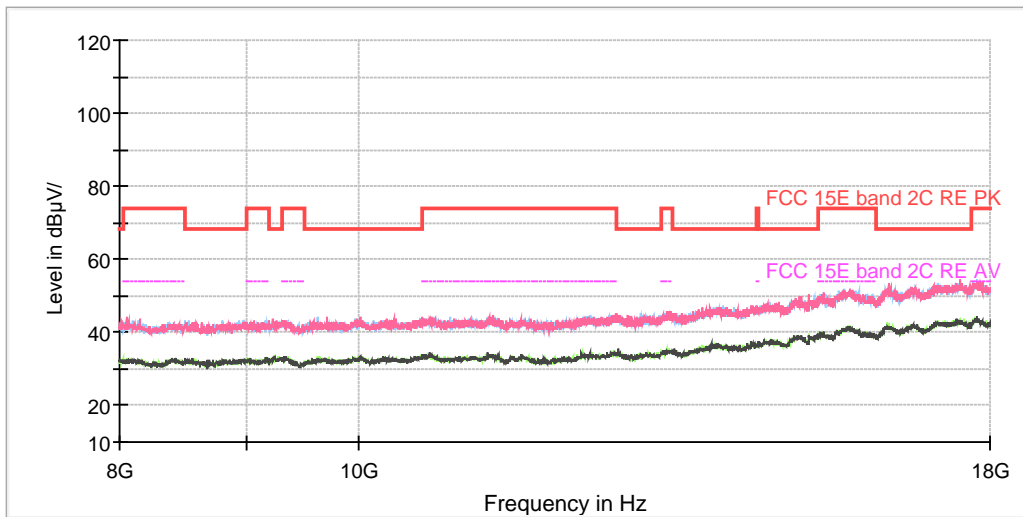

Radiates Emission from 8GHz to 18GHz



Frequency (MHz)	MaxPeak (dB μ V/m)	Average (dB μ V/m)	Height (cm)	Pol	Azimuth (deg)	Corr. (dB/m)	Margin (dB)	Limit (dB μ V/m)
1060.375000	42.02	---	100.0	H	141.0	-8.4	26.18	68.20
1392.000000	---	32.22	200.0	V	352.0	-6.5	21.78	54.00
1680.750000	---	33.78	200.0	H	203.0	-4.9	20.22	54.00
1980.875000	44.76	---	200.0	V	139.0	-3.3	23.44	68.20
2616.125000	46.47	---	200.0	H	273.0	-0.8	21.73	68.20
2760.500000	---	36.03	100.0	V	57.0	-0.1	17.97	54.00
3545.375000	48.97	---	100.0	H	95.0	3.0	19.23	68.20
3928.625000	---	38.81	200.0	V	338.0	4.3	15.19	54.00
5034.625000	---	40.83	200.0	V	1.0	6.7	13.17	54.00
5127.375000	51.36	---	100.0	V	185.0	6.8	16.84	68.20
7482.000000	---	43.11	100.0	V	85.0	10.2	10.89	54.00
7489.000000	52.63	---	100.0	H	334.0	10.2	21.37	74.00

Remark: 1. Correction Factor = Antenna factor+ Insertion loss (cable loss + amplifier gain)

802.11a CH116

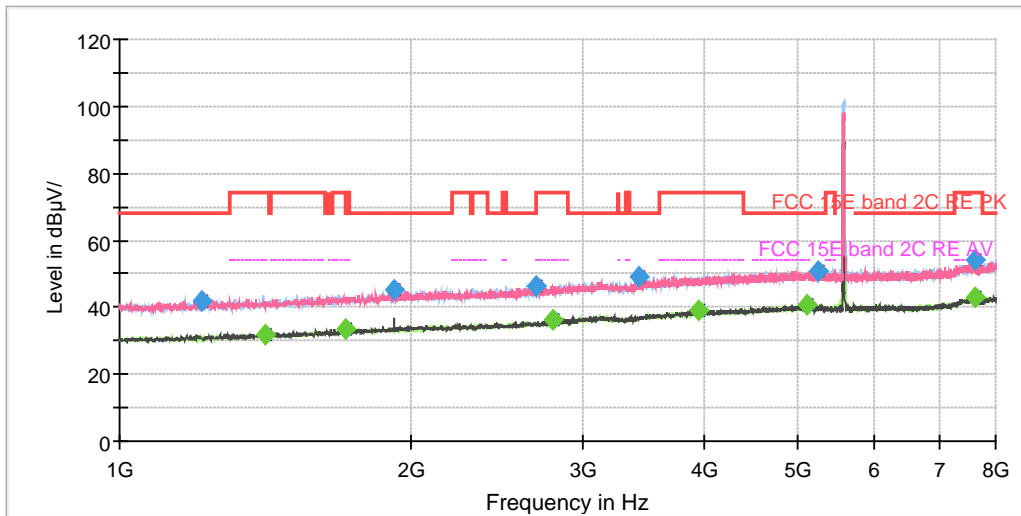

Note: The signal beyond the limit is carrier.
Radiates Emission from 1GHz to 8GHz

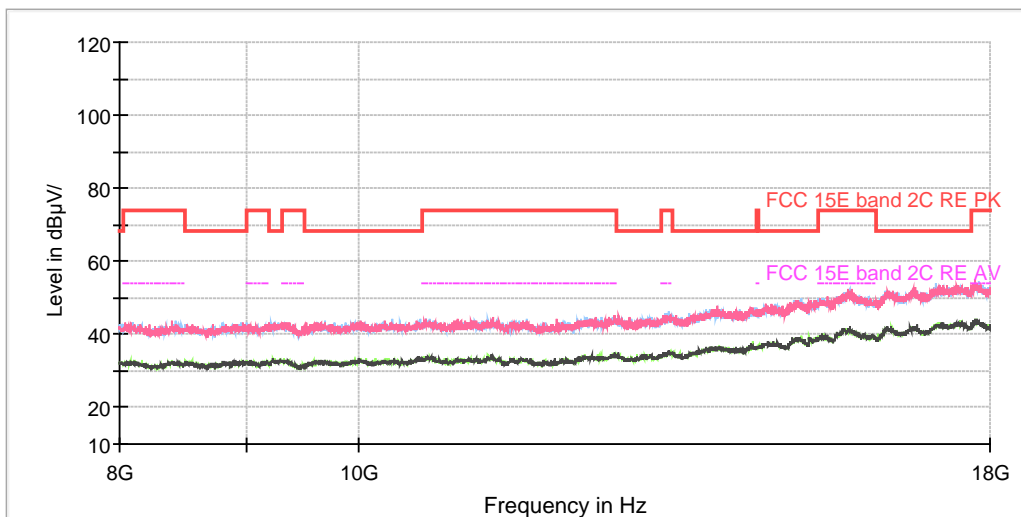

Radiates Emission from 8GHz to 18GHz



Frequency (MHz)	MaxPeak (dB μ V/m)	Average (dB μ V/m)	Height (cm)	Pol	Azimuth (deg)	Corr. (dB/m)	Margin (dB)	Limit (dB μ V/m)
1217.000000	42.04	---	200.0	V	180.0	-7.5	26.16	68.20
1412.125000	---	32.08	200.0	V	295.0	-6.4	21.92	54.00
1709.625000	---	33.31	100.0	V	121.0	-4.8	20.69	54.00
1919.625000	45.40	---	100.0	V	211.0	-3.6	22.80	68.20
2682.625000	46.46	---	200.0	H	8.0	-0.5	21.74	68.20
2800.750000	---	36.11	200.0	H	123.0	0.2	17.89	54.00
3424.625000	49.35	---	200.0	H	4.0	2.2	18.85	68.20
3954.875000	---	39.02	100.0	H	0.0	4.3	14.98	54.00
5113.375000	---	40.83	100.0	H	271.0	6.9	13.17	54.00
5255.125000	50.98	---	100.0	V	150.0	7.0	17.22	68.20
7609.750000	53.96	---	100.0	H	0.0	10.3	20.04	74.00
7620.250000	---	43.06	100.0	H	321.0	10.3	10.94	54.00

Remark: 1. Correction Factor = Antenna factor+ Insertion loss (cable loss + amplifier gain)

802.11a CH140

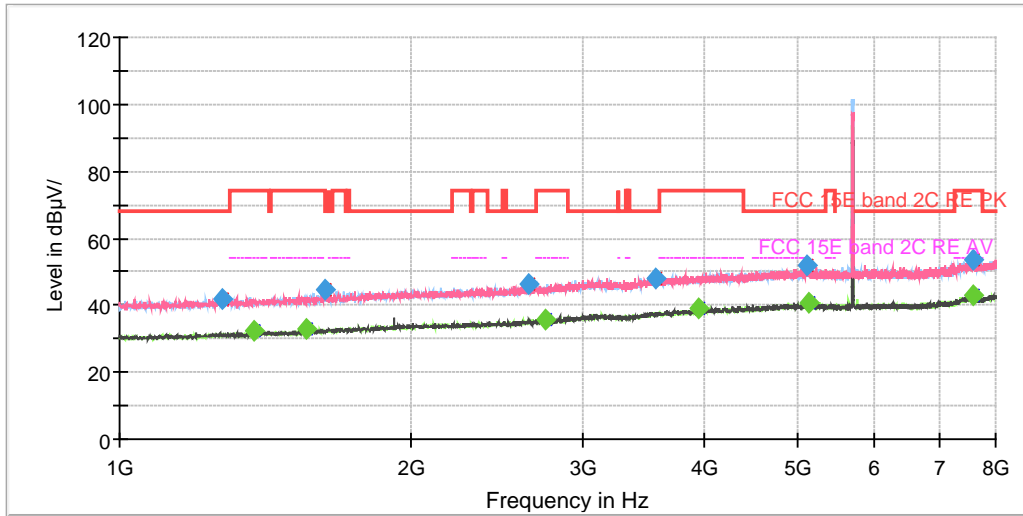

Note: The signal beyond the limit is carrier.
Radiates Emission from 1GHz to 8GHz

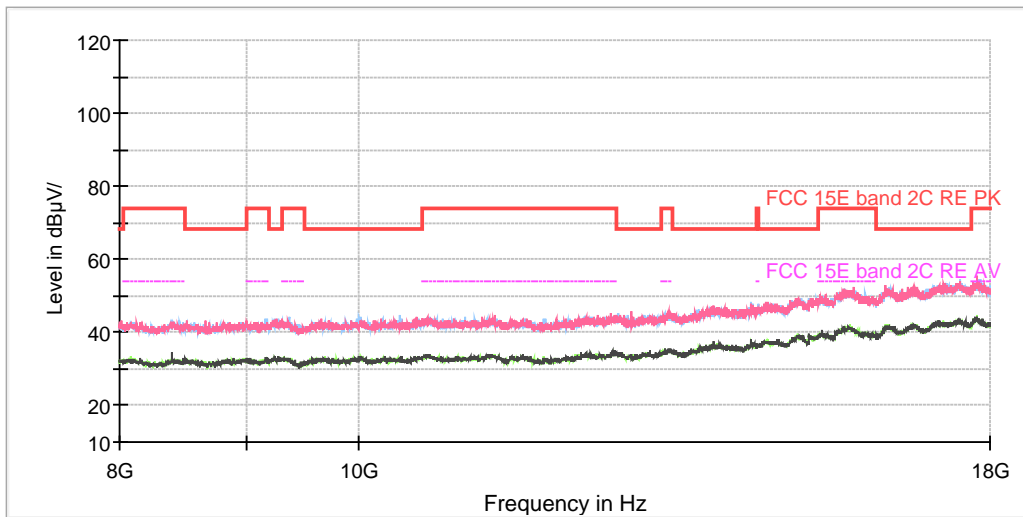

Radiates Emission from 8GHz to 18GHz



Frequency (MHz)	MaxPeak (dB μ V/m)	Average (dB μ V/m)	Height (cm)	Pol	Azimuth (deg)	Corr. (dB/m)	Margin (dB)	Limit (dB μ V/m)
1273.875000	41.85	---	200.0	H	333.0	-7.2	26.35	68.20
1378.875000	---	32.23	100.0	H	175.0	-6.6	21.77	54.00
1560.000000	---	33.15	200.0	V	163.0	-5.6	20.85	54.00
1631.750000	44.69	---	200.0	V	138.0	-5.2	23.51	68.20
2640.625000	46.41	---	200.0	H	65.0	-0.6	21.79	68.20
2753.500000	---	36.00	100.0	V	30.0	-0.1	18.00	54.00
3566.375000	48.18	---	100.0	H	0.0	3.1	20.02	68.20
3958.375000	---	39.20	200.0	H	284.0	4.3	14.80	54.00
5112.500000	51.84	---	100.0	H	69.0	6.9	16.36	68.20
5127.375000	---	40.54	100.0	H	123.0	6.8	13.46	54.00
7570.375000	53.65	---	200.0	V	301.0	10.3	20.35	74.00
7574.750000	---	42.73	200.0	V	293.0	10.3	11.27	54.00

Remark: 1. Correction Factor = Antenna factor+ Insertion loss (cable loss + amplifier gain)

802.11a CH149

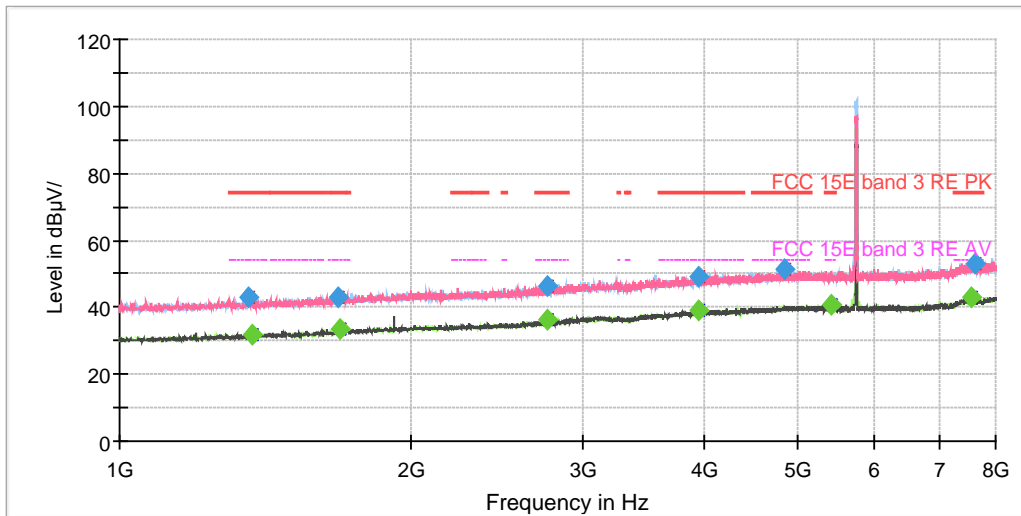

Note: The signal beyond the limit is carrier.
Radiates Emission from 1GHz to 8GHz

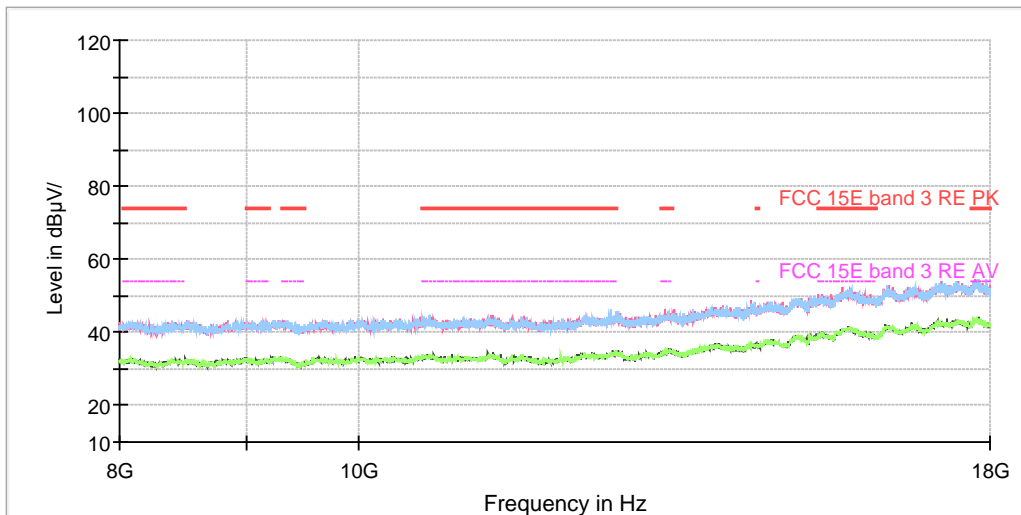

Radiates Emission from 8GHz to 18GHz



Frequency (MHz)	MaxPeak (dB μ V/m)	Average (dB μ V/m)	Height (cm)	Pol	Azimuth (deg)	Corr. (dB/m)	Margin (dB)	Limit (dB μ V/m)
1356.125000	43.09	---	200.0	V	301.0	-6.7	30.91	74.00
1369.250000	---	32.06	200.0	H	216.0	-6.6	21.94	54.00
1679.875000	43.17	---	100.0	V	107.0	-4.9	30.83	74.00
1688.625000	---	33.51	200.0	V	180.0	-4.9	20.49	54.00
2757.875000	46.23	---	100.0	V	207.0	-0.1	27.77	74.00
2760.500000	---	36.14	100.0	V	239.0	-0.1	17.86	54.00
3947.875000	---	38.84	200.0	V	332.0	4.3	15.16	54.00
3948.750000	49.35	---	100.0	H	309.0	4.3	24.65	74.00
4851.750000	51.34	---	100.0	V	129.0	6.3	22.66	74.00
5421.375000	---	40.59	100.0	H	0.0	7.1	13.41	54.00
7565.125000	---	42.81	200.0	H	103.0	10.3	11.19	54.00
7617.625000	53.15	---	100.0	H	108.0	10.3	20.85	74.00

Remark: 1. Correction Factor = Antenna factor+ Insertion loss (cable loss + amplifier gain)

802.11a CH157

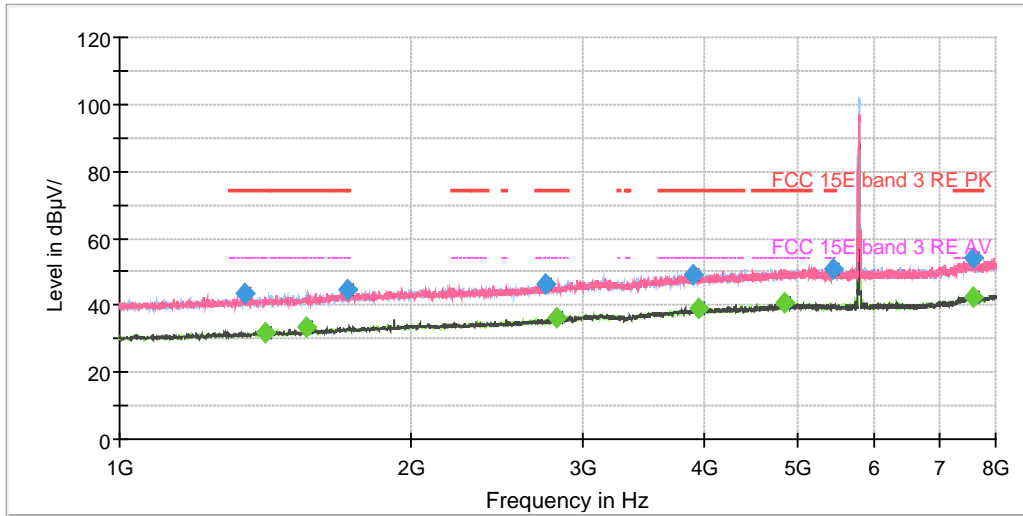

Note: The signal beyond the limit is carrier.
Radiates Emission from 1GHz to 8GHz

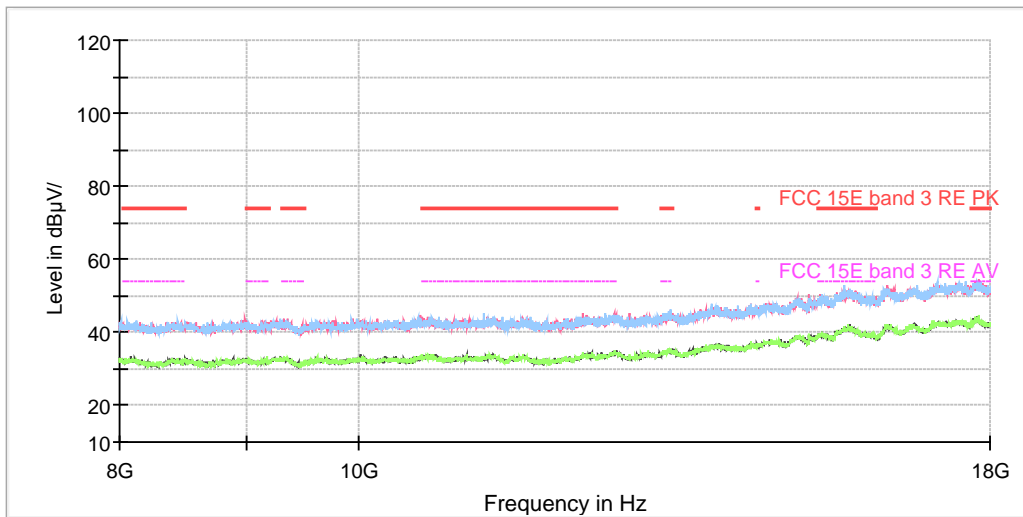

Radiates Emission from 8GHz to 18GHz



Frequency (MHz)	MaxPeak (dB μ V/m)	Average (dB μ V/m)	Height (cm)	Pol	Azimuth (deg)	Corr. (dB/m)	Margin (dB)	Limit (dB μ V/m)
1346.500000	43.40	---	200.0	H	5.0	-6.8	30.60	74.00
1410.375000	---	31.90	200.0	V	194.0	-6.4	22.10	54.00
1560.000000	---	33.54	100.0	V	5.0	-5.6	20.46	54.00
1719.250000	44.54	---	200.0	H	81.0	-4.7	29.46	74.00
2752.625000	46.60	---	200.0	V	184.0	-0.1	27.40	74.00
2822.625000	---	36.01	100.0	V	137.0	0.3	17.99	54.00
3898.000000	49.36	---	100.0	V	104.0	4.0	24.64	74.00
3951.375000	---	38.97	200.0	V	273.0	4.3	15.03	54.00
4856.125000	---	40.62	100.0	V	162.0	6.3	13.38	54.00
5430.125000	50.96	---	200.0	H	132.0	7.1	23.04	74.00
7580.875000	54.18	---	200.0	H	199.0	10.3	19.82	74.00
7594.000000	---	42.69	200.0	V	308.0	10.3	11.31	54.00

Remark: 1. Correction Factor = Antenna factor+ Insertion loss (cable loss + amplifier gain)

802.11a CH165

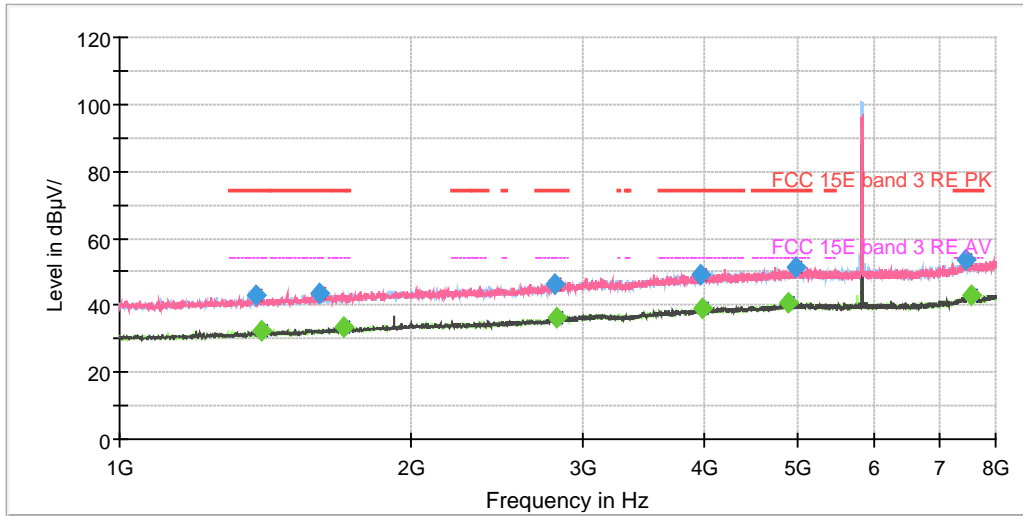

Note: The signal beyond the limit is carrier.
Radiates Emission from 1GHz to 8GHz

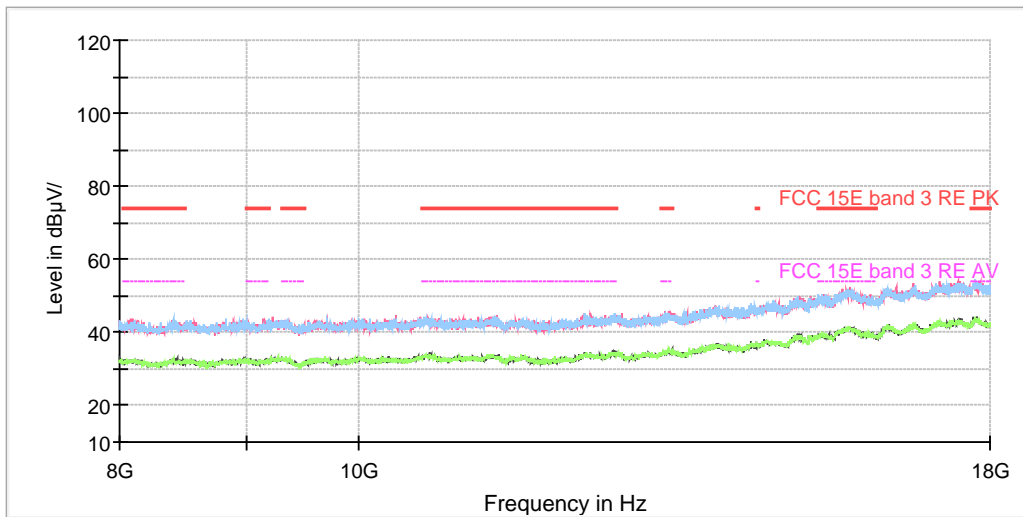

Radiates Emission from 8GHz to 18GHz



Frequency (MHz)	MaxPeak (dB μ V/m)	Average (dB μ V/m)	Height (cm)	Pol	Azimuth (deg)	Corr. (dB/m)	Margin (dB)	Limit (dB μ V/m)
1382.375000	42.85	---	100.0	H	358.0	-6.5	31.15	74.00
1399.875000	---	32.34	200.0	V	215.0	-6.5	21.66	54.00
1604.625000	43.61	---	200.0	V	70.0	-5.4	30.39	74.00
1704.375000	---	33.33	100.0	V	36.0	-4.8	20.67	54.00
2808.625000	46.60	---	200.0	V	358.0	0.2	27.40	74.00
2825.250000	---	36.14	200.0	V	126.0	0.3	17.86	54.00
3961.875000	49.34	---	100.0	H	161.0	4.3	24.66	74.00
3993.375000	---	39.15	100.0	H	25.0	4.3	14.85	54.00
4892.875000	---	40.94	100.0	H	254.0	6.4	13.06	54.00
4970.750000	51.38	---	200.0	V	344.0	6.5	22.62	74.00
7461.000000	53.45	---	100.0	V	146.0	10.1	20.55	74.00
7566.000000	---	42.76	100.0	V	238.0	10.3	11.24	54.00

Remark: 1. Correction Factor = Antenna factor+ Insertion loss (cable loss + amplifier gain)

802.11n (HT20) CH36

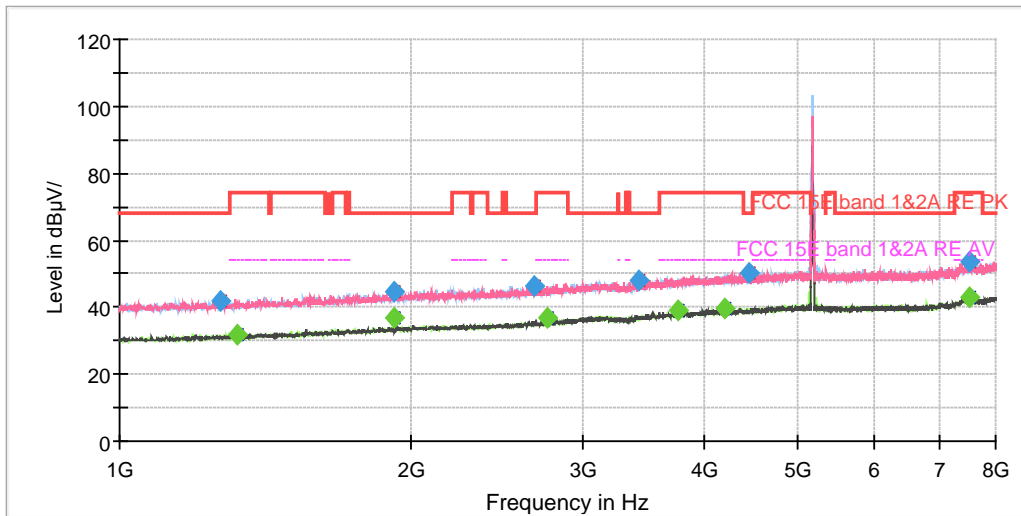

Note: The signal beyond the limit is carrier.
Radiates Emission from 1GHz to 8GHz

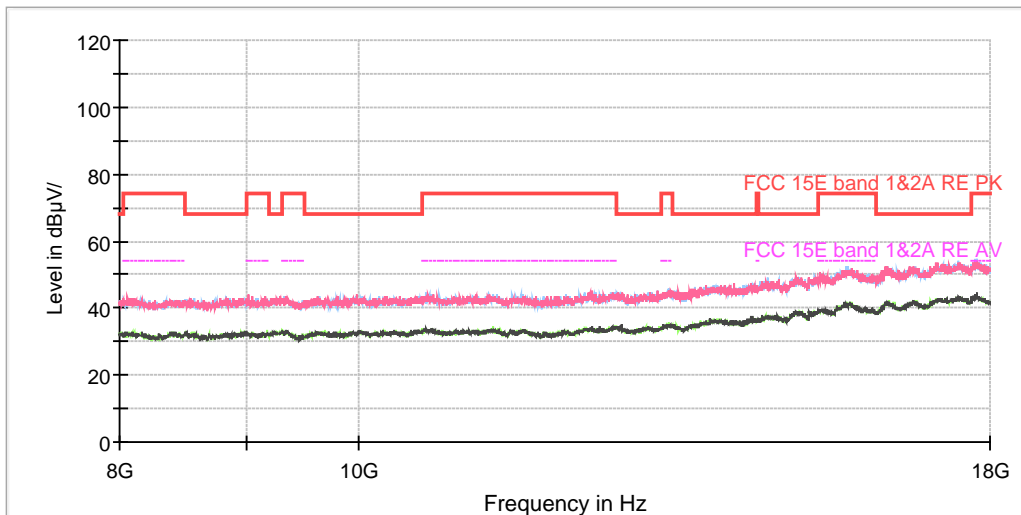

Radiates Emission from 8GHz to 18GHz



Frequency (MHz)	MaxPeak (dB μ V/m)	Average (dB μ V/m)	Height (cm)	Pol	Azimuth (deg)	Corr. (dB/m)	Margin (dB)	Limit (dB μ V/m)
1267.750000	42.09	---	200.0	V	238.0	-7.2	26.11	68.20
1319.375000	---	32.08	100.0	V	33.0	-6.9	21.92	54.00
1919.625000	---	36.62	100.0	V	158.0	-3.6	17.38	54.00
1919.625000	44.83	---	200.0	V	220.0	-3.6	23.37	68.20
2681.750000	46.40	---	100.0	H	152.0	-0.5	21.80	68.20
2760.500000	---	36.92	100.0	V	0.0	-0.1	17.08	54.00
3433.375000	48.20	---	200.0	H	174.0	2.3	20.00	68.20
3760.625000	---	39.03	100.0	H	284.0	3.7	14.97	54.00
4208.625000	---	39.45	100.0	V	0.0	4.8	14.55	54.00
4465.000000	50.26	---	200.0	V	0.0	5.1	17.94	68.20
7517.000000	53.36	---	100.0	H	358.0	10.2	20.64	74.00
7527.500000	---	42.83	100.0	H	340.0	10.2	11.17	54.00

Remark: 1. Correction Factor = Antenna factor+ Insertion loss (cable loss + amplifier gain)

802.11n (HT20) CH44

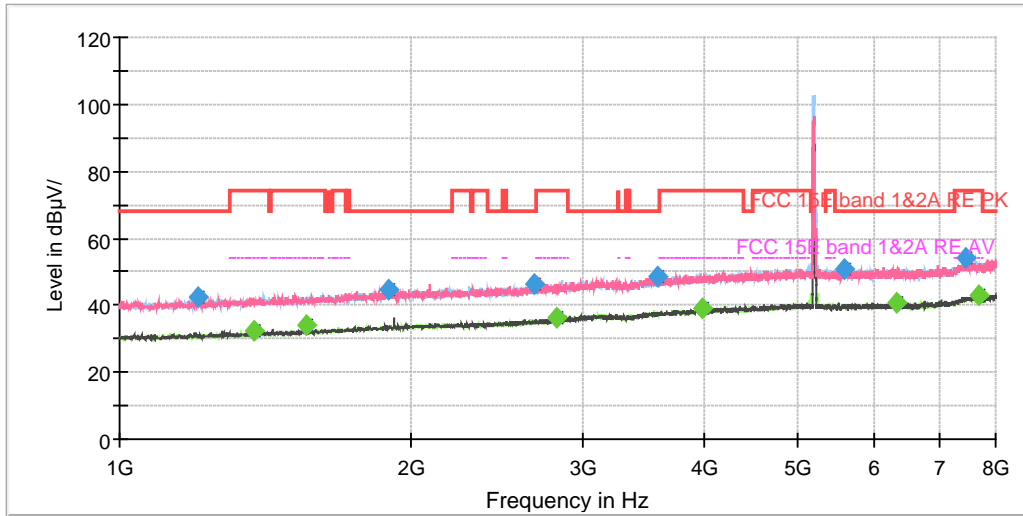

Note: The signal beyond the limit is carrier.
Radiates Emission from 1GHz to 8GHz

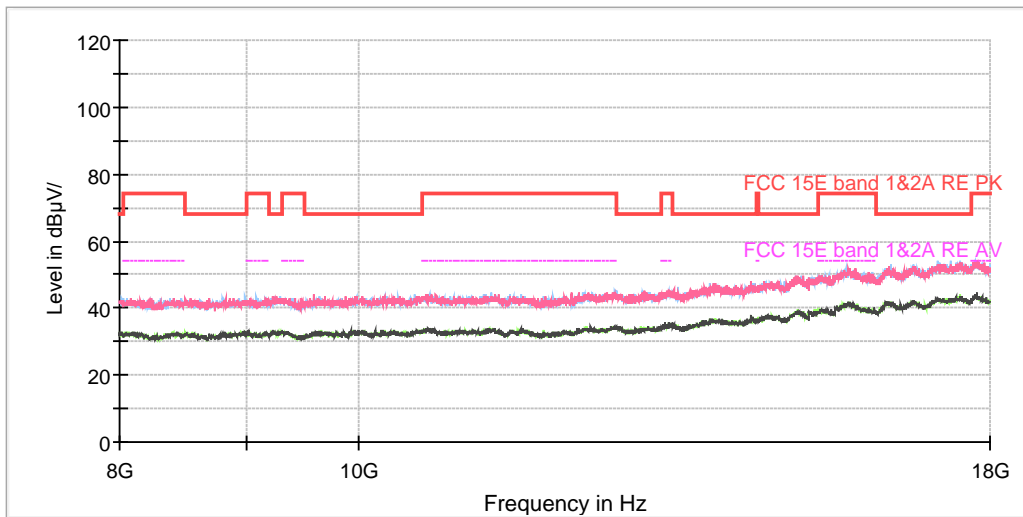

Radiates Emission from 8GHz to 18GHz



Frequency (MHz)	MaxPeak (dB μ V/m)	Average (dB μ V/m)	Height (cm)	Pol	Azimuth (deg)	Corr. (dB/m)	Margin (dB)	Limit (dB μ V/m)
1202.125000	42.31	---	200.0	H	195.0	-7.6	25.89	68.20
1375.375000	---	32.24	200.0	H	99.0	-6.6	21.76	54.00
1560.000000	---	34.10	200.0	V	182.0	-5.6	19.90	54.00
1893.375000	44.66	---	100.0	H	135.0	-3.8	23.54	68.20
2673.875000	46.56	---	100.0	V	176.0	-0.5	21.64	68.20
2825.250000	---	36.05	200.0	H	60.0	0.3	17.95	54.00
3590.000000	48.67	---	200.0	H	81.0	3.2	19.53	68.20
3995.125000	---	38.91	200.0	V	260.0	4.4	15.09	54.00
5588.500000	50.62	---	100.0	V	278.0	7.5	17.58	68.20
6337.500000	---	40.83	200.0	V	263.0	8.5	13.17	54.00
7440.000000	53.93	---	200.0	V	136.0	10.1	20.07	74.00
7702.500000	---	42.75	200.0	H	346.0	10.3	11.25	54.00

Remark: 1. Correction Factor = Antenna factor+ Insertion loss (cable loss + amplifier gain)

802.11n (HT20) CH48

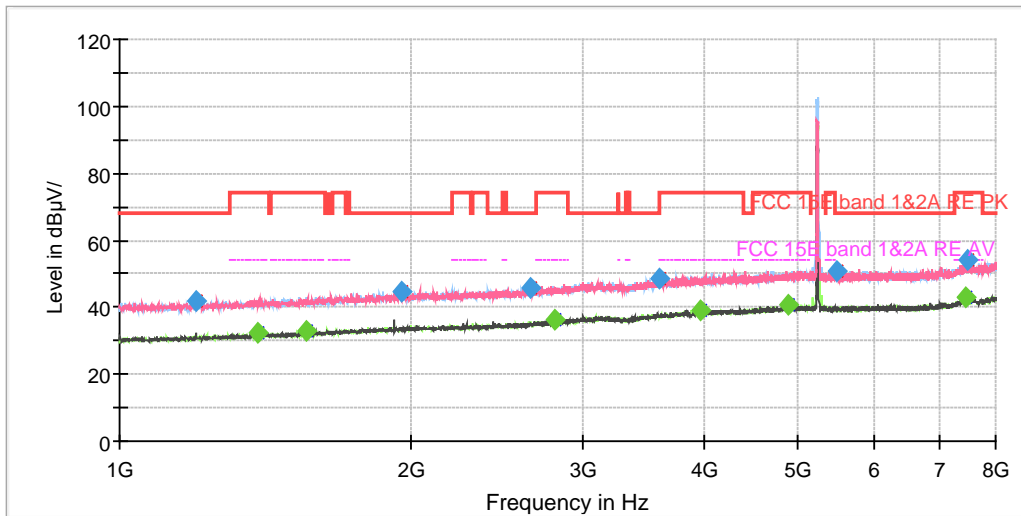

Note: The signal beyond the limit is carrier.
Radiates Emission from 1GHz to 8GHz

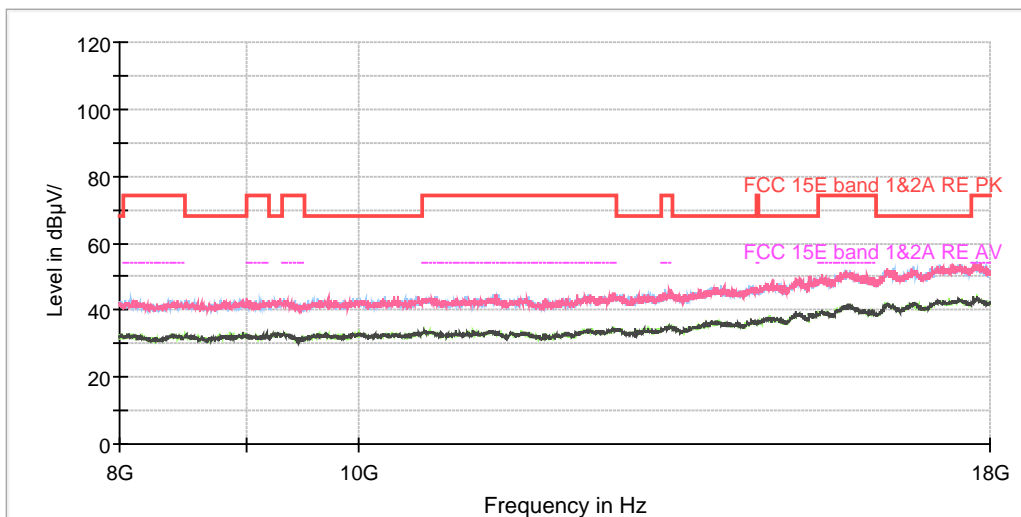

Radiates Emission from 8GHz to 18GHz



Frequency (MHz)	MaxPeak (dB μ V/m)	Average (dB μ V/m)	Height (cm)	Pol	Azimuth (deg)	Corr. (dB/m)	Margin (dB)	Limit (dB μ V/m)
1199.500000	41.87	---	100.0	H	216.0	-7.6	26.33	68.20
1386.750000	---	32.23	200.0	V	330.0	-6.5	21.77	54.00
1560.000000	---	33.16	100.0	V	8.0	-5.6	20.84	54.00
1950.250000	44.57	---	200.0	H	52.0	-3.5	23.63	68.20
2656.375000	46.03	---	200.0	H	136.0	-0.6	22.17	68.20
2813.000000	---	36.34	200.0	H	56.0	0.2	17.66	54.00
3594.375000	48.31	---	200.0	V	101.0	3.3	19.89	68.20
3969.750000	---	39.20	100.0	V	127.0	4.3	14.80	54.00
4892.875000	---	40.65	100.0	H	12.0	6.4	13.35	54.00
5484.375000	50.71	---	200.0	H	344.0	7.3	17.49	68.20
7460.125000	---	42.74	100.0	V	107.0	10.1	11.26	54.00
7488.125000	53.97	---	100.0	V	29.0	10.2	20.03	74.00

Remark: 1. Correction Factor = Antenna factor+ Insertion loss (cable loss + amplifier gain)

802.11n (HT20) CH52

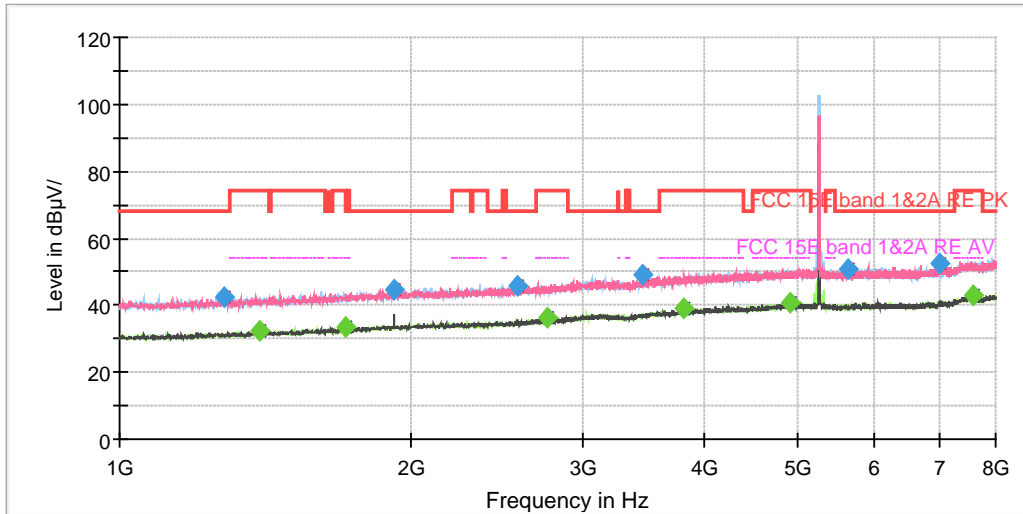

Note: The signal beyond the limit is carrier.
Radiates Emission from 1GHz to 8GHz

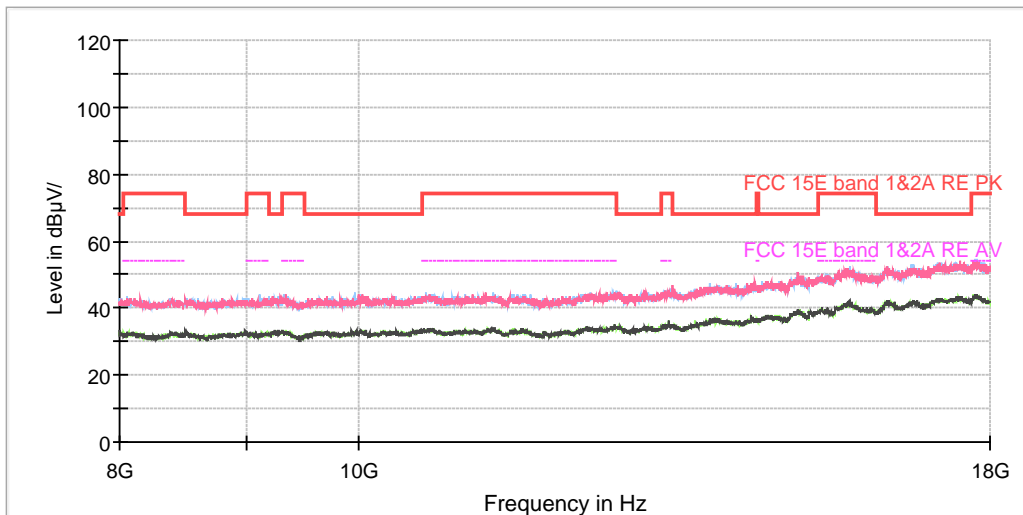

Radiates Emission from 8GHz to 18GHz



Frequency (MHz)	MaxPeak (dB μ V/m)	Average (dB μ V/m)	Height (cm)	Pol	Azimuth (deg)	Corr. (dB/m)	Margin (dB)	Limit (dB μ V/m)
1281.750000	42.53	---	200.0	200.0	H	6.0	25.67	68.20
1396.375000	---	32.17	200.0	100.0	H	295.0	21.83	54.00
1707.875000	---	33.34	200.0	100.0	H	349.0	20.66	54.00
1915.250000	44.54	---	200.0	100.0	V	0.0	23.66	68.20
2572.375000	45.73	---	200.0	100.0	H	277.0	22.47	68.20
2759.625000	---	36.17	200.0	100.0	V	60.0	17.83	54.00
3455.250000	49.09	---	200.0	100.0	V	0.0	19.11	68.20
3816.625000	---	38.80	200.0	100.0	H	237.0	15.20	54.00
4920.000000	---	40.59	200.0	100.0	V	134.0	13.41	54.00
5629.625000	50.76	---	200.0	200.0	V	309.0	17.44	68.20
7001.625000	52.67	---	200.0	100.0	H	199.0	15.53	68.20
7577.375000	---	42.70	200.0	100.0	H	309.0	11.30	54.00

Remark: 1. Correction Factor = Antenna factor+ Insertion loss (cable loss + amplifier gain)

802.11n (HT20) CH60

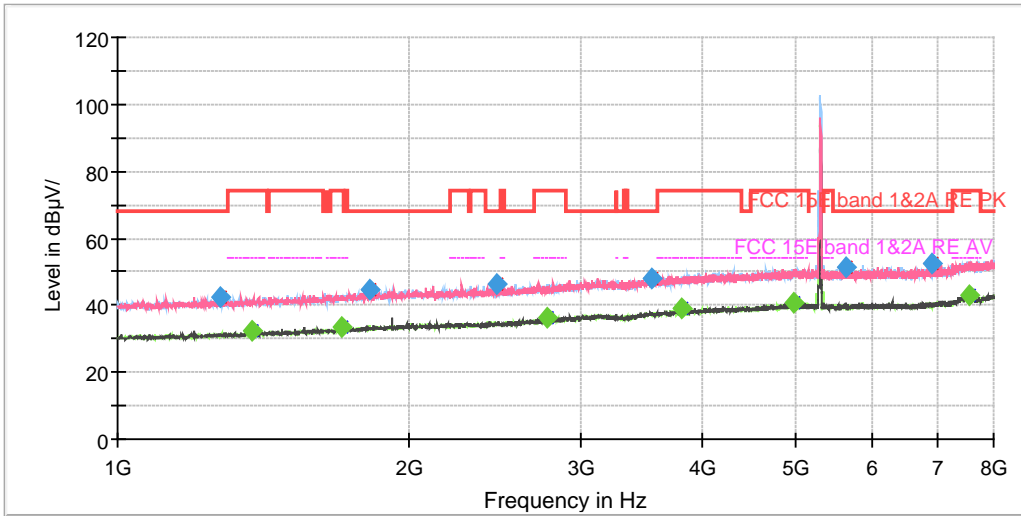

Note: The signal beyond the limit is carrier.
Radiates Emission from 1GHz to 8GHz

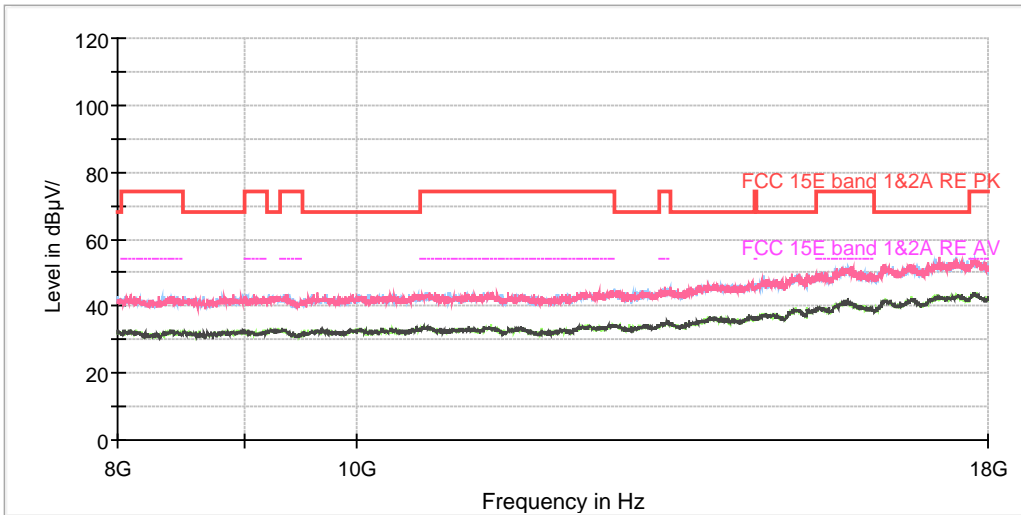

Radiates Emission from 8GHz to 18GHz



Frequency (MHz)	MaxPeak (dB μ V/m)	Average (dB μ V/m)	Height (cm)	Pol	Azimuth (deg)	Corr. (dB/m)	Margin (dB)	Limit (dB μ V/m)
1277.375000	42.26	---	200.0	200.0	H	147.0	25.94	68.20
1378.875000	---	32.46	200.0	200.0	V	353.0	21.54	54.00
1705.250000	---	33.48	200.0	100.0	H	74.0	20.52	54.00
1819.875000	44.81	---	200.0	200.0	H	29.0	23.39	68.20
2460.375000	46.20	---	200.0	200.0	V	191.0	22.00	68.20
2775.375000	---	36.31	200.0	200.0	H	108.0	17.69	54.00
3555.000000	48.02	---	200.0	100.0	H	244.0	20.18	68.20
3812.250000	---	39.00	200.0	200.0	H	46.0	15.00	54.00
4967.250000	---	40.80	200.0	200.0	V	328.0	13.20	54.00
5637.500000	51.20	---	200.0	200.0	H	179.0	17.00	68.20
6918.500000	52.31	---	200.0	100.0	V	63.0	15.89	68.20
7568.625000	---	42.72	200.0	100.0	H	226.0	11.28	54.00

Remark: 1. Correction Factor = Antenna factor+ Insertion loss (cable loss + amplifier gain)

802.11n (HT20) CH64

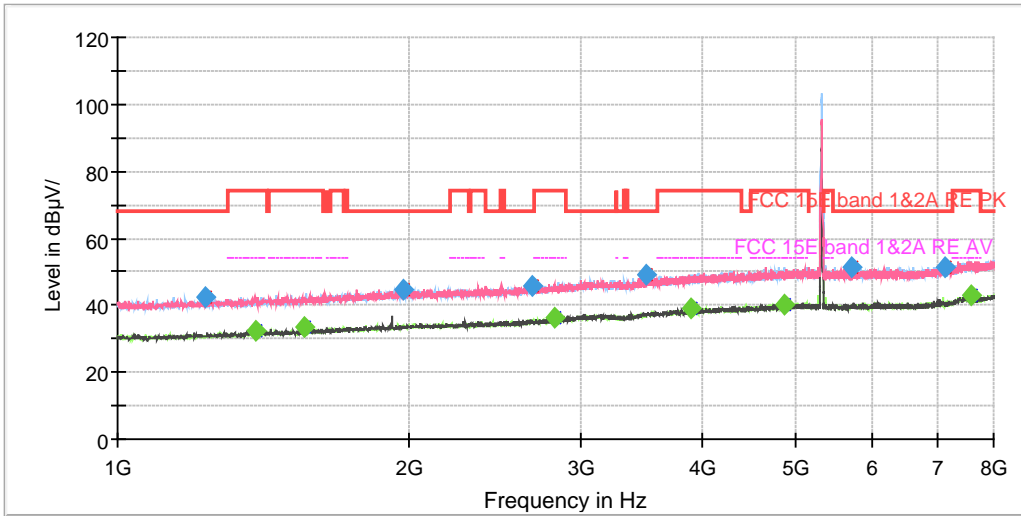

Note: The signal beyond the limit is carrier.
Radiates Emission from 1GHz to 8GHz

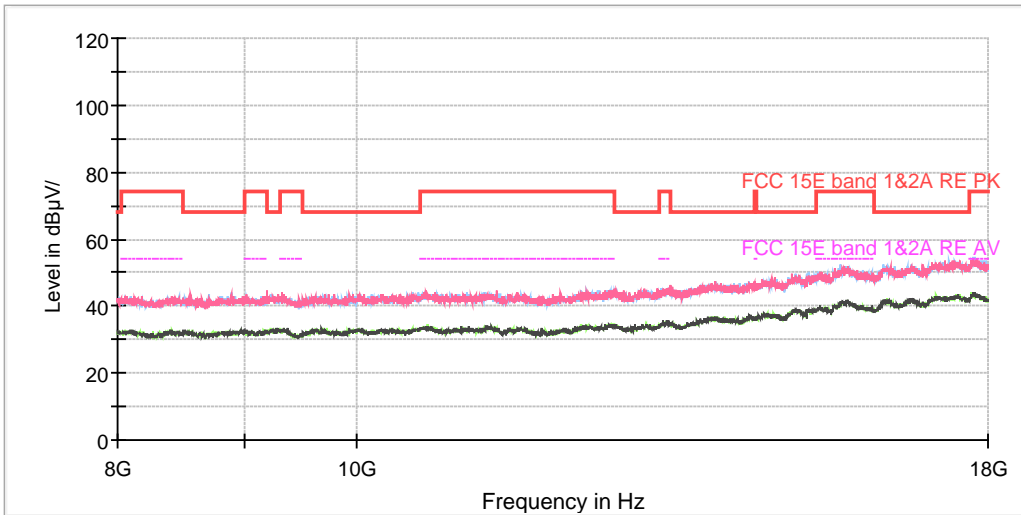

Radiates Emission from 8GHz to 18GHz



Frequency (MHz)	MaxPeak (dB μ V/m)	Average (dB μ V/m)	Height (cm)	Pol	Azimuth (deg)	Corr. (dB/m)	Margin (dB)	Limit (dB μ V/m)
1232.750000	42.42	---	200.0	H	207.0	-7.4	25.78	68.20
1388.500000	---	32.11	200.0	V	79.0	-6.5	21.89	54.00
1560.000000	---	33.73	100.0	V	338.0	-5.6	20.27	54.00
1974.750000	44.75	---	200.0	H	239.0	-3.3	23.45	68.20
2680.000000	45.99	---	100.0	V	327.0	-0.5	22.21	68.20
2823.500000	---	36.41	200.0	H	254.0	0.3	17.59	54.00
3512.125000	48.86	---	200.0	V	183.0	2.8	19.34	68.20
3907.625000	---	38.80	200.0	V	0.0	4.1	15.20	54.00
4862.250000	---	40.28	200.0	H	268.0	6.3	13.72	54.00
5704.875000	51.40	---	100.0	V	353.0	7.6	16.80	68.20
7123.250000	51.41	---	200.0	V	68.0	9.5	16.79	68.20
7594.000000	---	42.70	200.0	V	72.0	10.3	11.30	54.00

Remark: 1. Correction Factor = Antenna factor+ Insertion loss (cable loss + amplifier gain)

802.11n (HT20) CH100

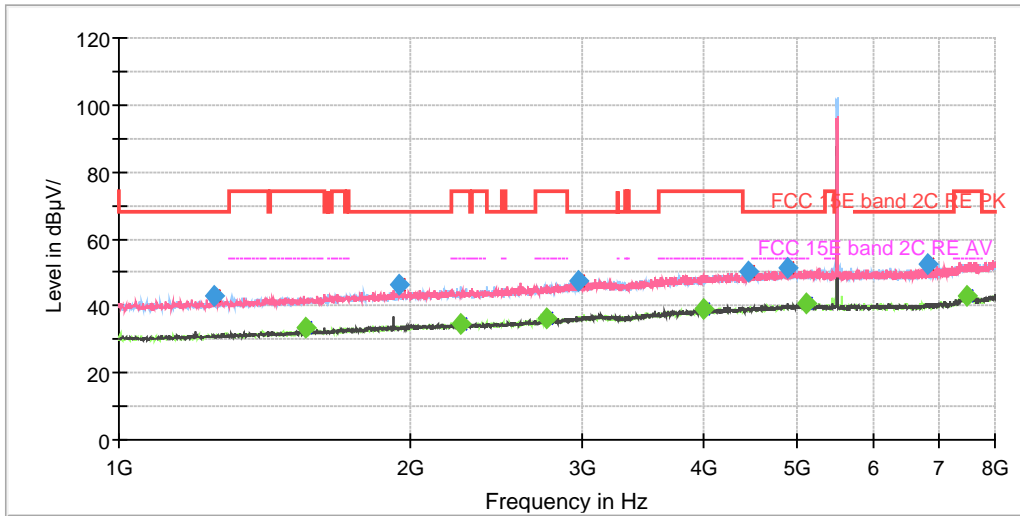

Note: The signal beyond the limit is carrier.
Radiates Emission from 1GHz to 8GHz

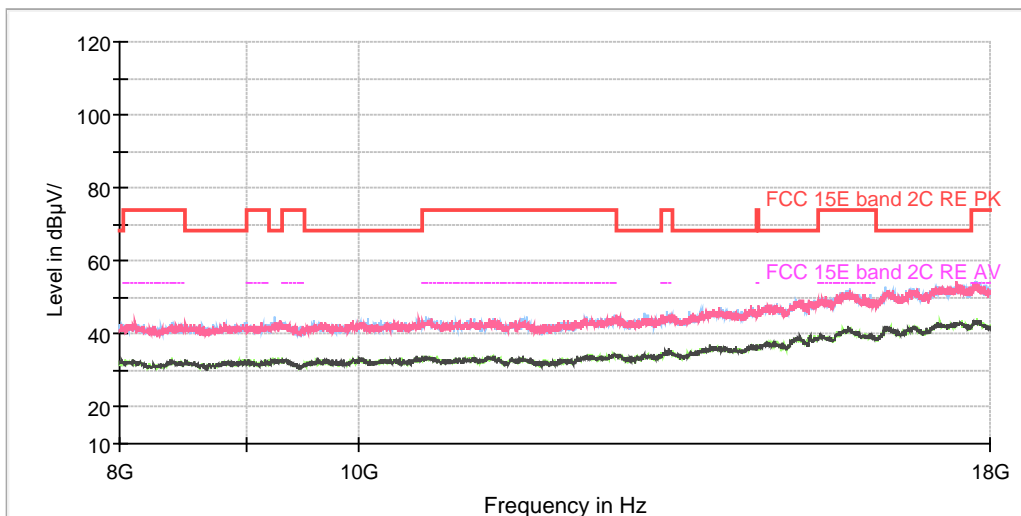

Radiates Emission from 8GHz to 18GHz



Frequency (MHz)	MaxPeak (dB μ V/m)	Average (dB μ V/m)	Height (cm)	Pol	Azimuth (deg)	Corr. (dB/m)	Margin (dB)	Limit (dB μ V/m)
1255.500000	42.71	---	200.0	V	16.0	-7.3	25.49	68.20
1560.000000	---	33.57	100.0	V	149.0	-5.6	20.43	54.00
1948.500000	46.33	---	200.0	H	223.0	-3.5	21.87	68.20
2250.375000	---	34.67	200.0	V	32.0	-2.3	19.33	54.00
2759.625000	---	36.23	200.0	V	58.0	-0.1	17.77	54.00
2982.750000	47.60	---	200.0	H	179.0	1.3	20.60	68.20
4013.500000	---	38.99	200.0	V	136.0	4.4	15.01	54.00
4453.625000	50.01	---	100.0	V	152.0	5.1	18.19	68.20
4895.500000	51.31	---	100.0	V	41.0	6.4	16.89	68.20
5119.500000	---	40.62	200.0	H	258.0	6.8	13.38	54.00
6807.375000	52.36	---	100.0	V	109.0	8.9	15.84	68.20
7490.750000	---	42.79	200.0	V	310.0	10.2	11.21	54.00

Remark: 1. Correction Factor = Antenna factor+ Insertion loss (cable loss + amplifier gain)

802.11n (HT20) CH116

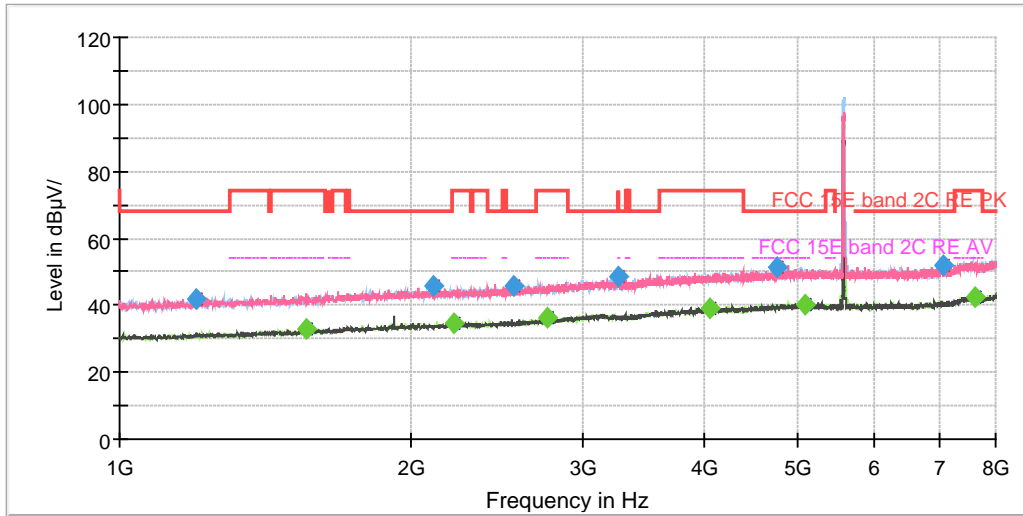

Note: The signal beyond the limit is carrier.
Radiates Emission from 1GHz to 8GHz

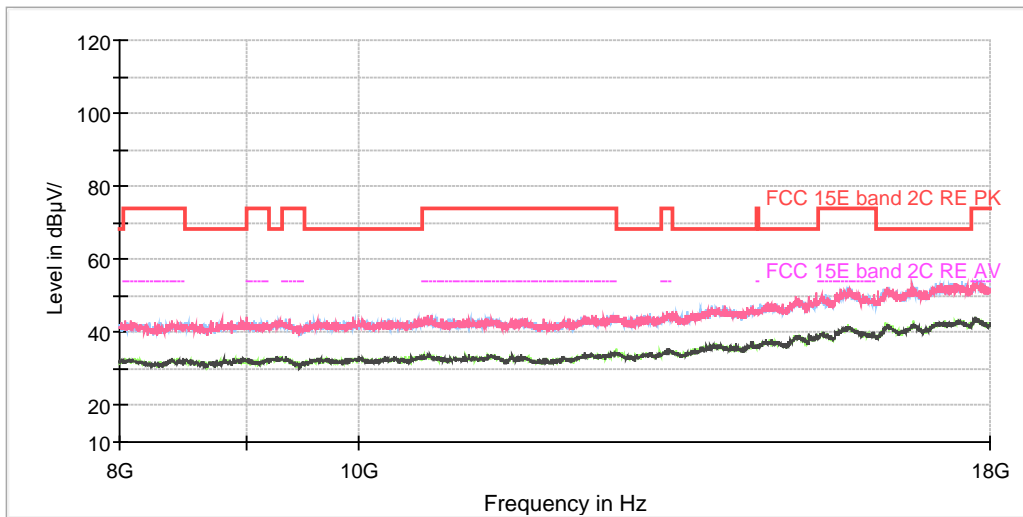

Radiates Emission from 8GHz to 18GHz



Frequency (MHz)	MaxPeak (dB μ V/m)	Average (dB μ V/m)	Height (cm)	Pol	Azimuth (deg)	Corr. (dB/m)	Margin (dB)	Limit (dB μ V/m)
1199.500000	41.98	---	200.0	V	157.0	-7.6	26.22	68.20
1560.000000	---	33.18	100.0	V	18.0	-5.6	20.82	54.00
2103.375000	45.79	---	100.0	H	132.0	-2.7	22.41	68.20
2211.000000	---	34.41	200.0	H	288.0	-2.4	19.59	54.00
2548.750000	45.54	---	200.0	H	233.0	-1.1	22.66	68.20
2760.500000	---	36.17	200.0	V	2.0	-0.1	17.83	54.00
3267.125000	48.45	---	100.0	H	202.0	1.8	19.75	68.20
4051.125000	---	39.27	200.0	V	241.0	4.5	14.73	54.00
4755.500000	51.30	---	100.0	V	254.0	6.0	16.90	68.20
5095.875000	---	40.34	100.0	H	59.0	6.9	13.66	54.00
7076.000000	52.18	---	200.0	H	288.0	9.4	16.02	68.20
7607.125000	---	42.52	200.0	V	154.0	10.3	11.48	54.00

Remark: 1. Correction Factor = Antenna factor+ Insertion loss (cable loss + amplifier gain)

802.11n (HT20) CH140

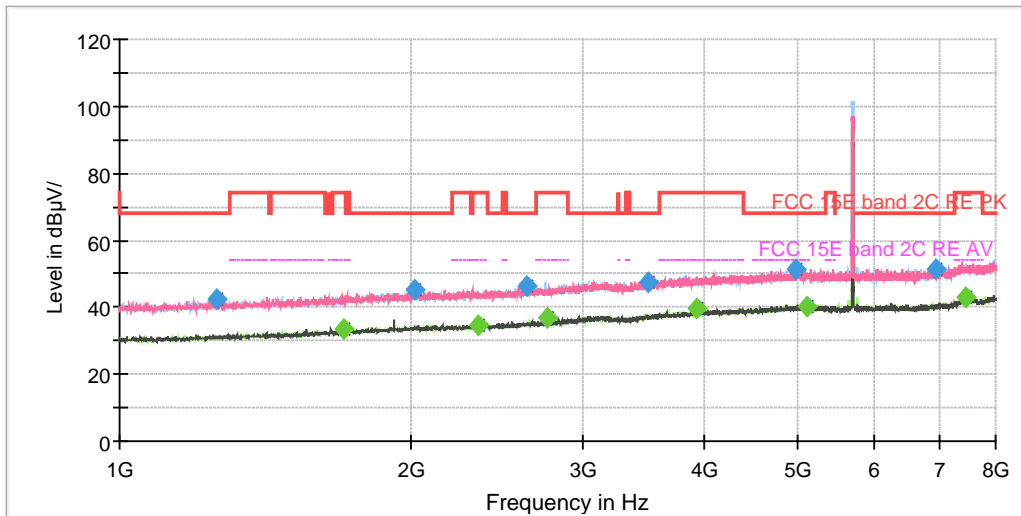

Note: The signal beyond the limit is carrier.
Radiates Emission from 1GHz to 8GHz

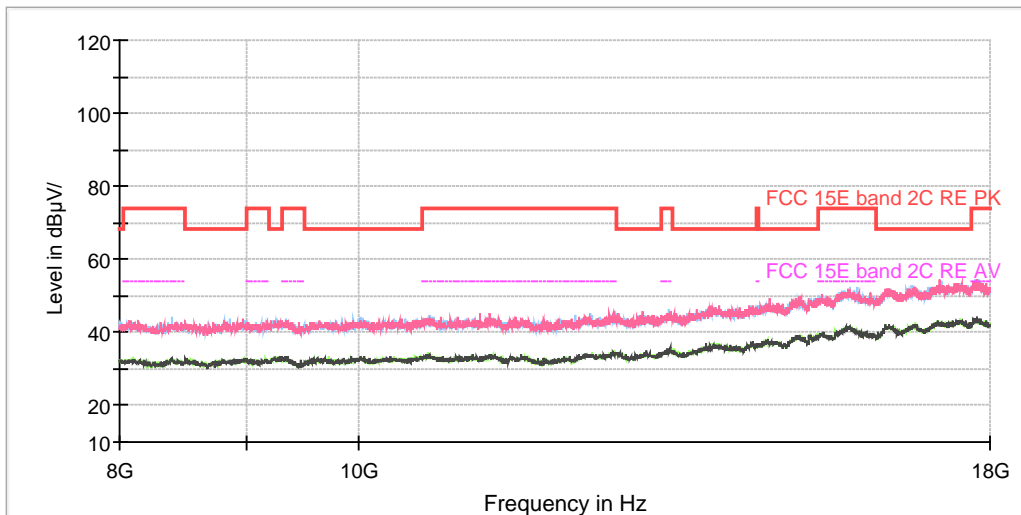

Radiates Emission from 8GHz to 18GHz



Frequency (MHz)	MaxPeak (dB μ V/m)	Average (dB μ V/m)	Height (cm)	Pol	Azimuth (deg)	Corr. (dB/m)	Margin (dB)	Limit (dB μ V/m)
1257.250000	42.30	---	200.0	V	5.0	-7.3	25.90	68.20
1704.375000	---	33.31	200.0	V	328.0	-4.8	20.69	54.00
2015.875000	44.97	---	100.0	V	0.0	-3.1	23.23	68.20
2343.125000	---	34.47	200.0	H	275.0	-1.9	19.53	54.00
2627.500000	46.12	---	200.0	H	347.0	-0.7	22.08	68.20
2759.625000	---	36.69	200.0	V	58.0	-0.1	17.31	54.00
3509.500000	47.48	---	100.0	V	116.0	2.8	20.72	68.20
3928.625000	---	39.43	100.0	V	285.0	4.3	14.57	54.00
4972.500000	51.30	---	100.0	H	200.0	6.5	16.90	68.20
5113.375000	---	40.32	100.0	V	243.0	6.9	13.68	54.00
6936.875000	51.27	---	200.0	V	58.0	9.1	16.93	68.20
7454.000000	---	42.94	200.0	V	55.0	10.1	11.06	54.00

Remark: 1. Correction Factor = Antenna factor+ Insertion loss (cable loss + amplifier gain)

802.11n (HT20) CH149

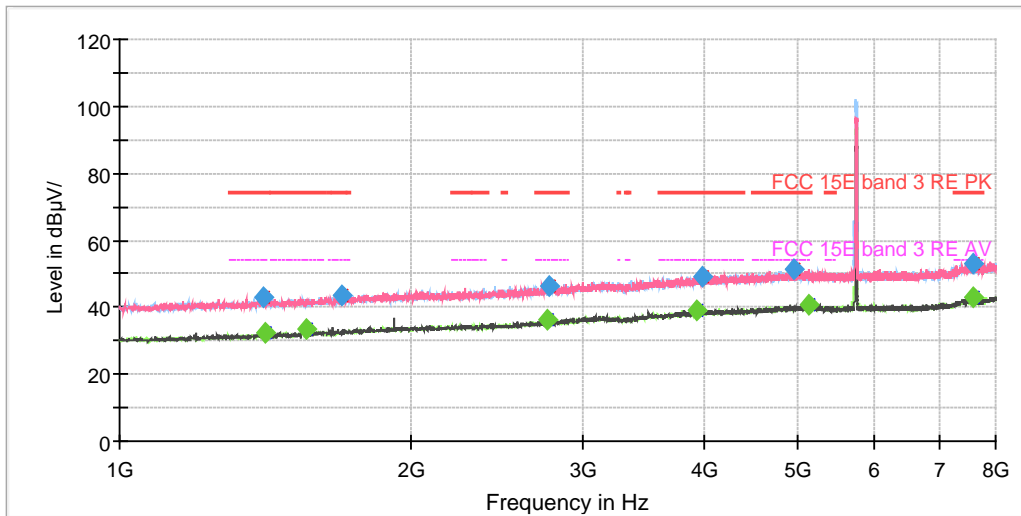

Note: The signal beyond the limit is carrier.
Radiates Emission from 1GHz to 8GHz

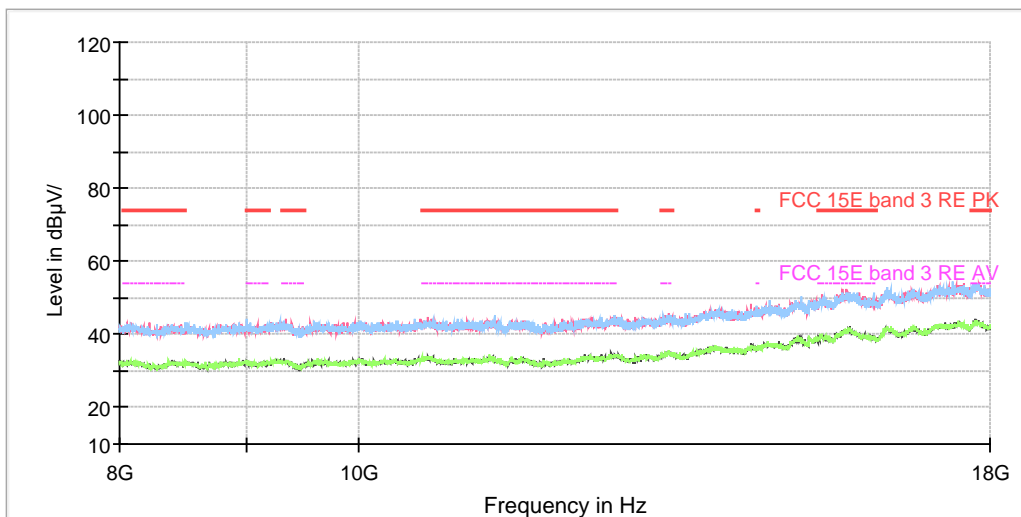

Radiates Emission from 8GHz to 18GHz



Frequency (MHz)	MaxPeak (dB μ V/m)	Average (dB μ V/m)	Height (cm)	Pol	Azimuth (deg)	Corr. (dB/m)	Margin (dB)	Limit (dB μ V/m)
1405.125000	43.14	---	200.0	V	140.0	-6.4	30.86	74.00
1413.875000	---	32.27	200.0	V	189.0	-6.4	21.73	54.00
1560.000000	---	33.77	200.0	V	182.0	-5.6	20.23	54.00
1697.375000	43.64	---	200.0	H	0.0	-4.9	30.36	74.00
2759.625000	---	36.44	100.0	V	56.0	-0.1	17.56	54.00
2769.250000	46.48	---	100.0	H	0.0	0.0	27.52	74.00
3928.625000	---	39.00	100.0	H	111.0	4.3	15.00	54.00
3989.875000	49.28	---	100.0	V	56.0	4.3	24.72	74.00
4966.375000	51.62	---	100.0	V	166.0	6.5	22.38	74.00
5132.625000	---	40.57	100.0	H	276.0	6.8	13.43	54.00
7569.500000	---	42.88	200.0	H	224.0	10.3	11.12	54.00
7587.875000	52.77	---	100.0	V	96.0	10.3	21.23	74.00

Remark: 1. Correction Factor = Antenna factor+ Insertion loss (cable loss + amplifier gain)

802.11n (HT20) CH157

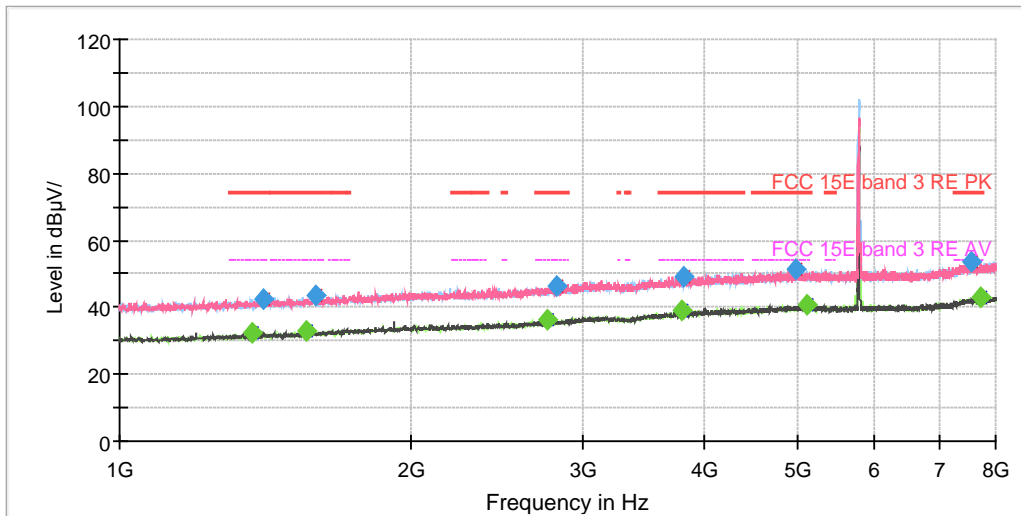

Note: The signal beyond the limit is carrier.
Radiates Emission from 1GHz to 8GHz

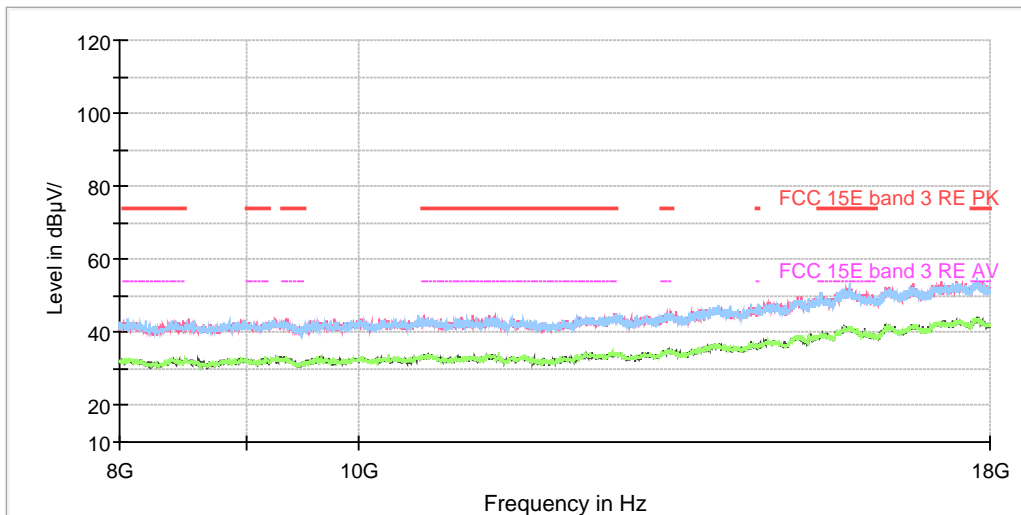

Radiates Emission from 8GHz to 18GHz



Frequency (MHz)	MaxPeak (dB μ V/m)	Average (dB μ V/m)	Height (cm)	Pol	Azimuth (deg)	Corr. (dB/m)	Margin (dB)	Limit (dB μ V/m)
1369.250000	---	32.32	100.0	V	318.0	-6.6	21.68	54.00
1407.750000	42.59	---	100.0	H	72.0	-6.4	31.41	74.00
1560.000000	---	33.19	100.0	V	184.0	-5.6	20.81	54.00
1594.125000	43.73	---	200.0	H	118.0	-5.4	30.27	74.00
2760.500000	---	36.14	100.0	V	336.0	-0.1	17.86	54.00
2827.000000	46.26	---	100.0	H	40.0	0.3	27.74	74.00
3800.000000	---	38.91	100.0	V	266.0	3.8	15.09	54.00
3819.250000	49.39	---	100.0	V	194.0	3.9	24.61	74.00
4980.375000	51.27	---	200.0	H	294.0	6.6	22.73	74.00
5112.500000	---	40.51	100.0	V	262.0	6.9	13.49	54.00
7553.750000	53.67	---	100.0	V	223.0	10.3	20.33	74.00
7716.500000	---	43.06	100.0	V	47.0	10.4	10.94	54.00

Remark: 1. Correction Factor = Antenna factor+ Insertion loss (cable loss + amplifier gain)



802.11n (HT20) CH165

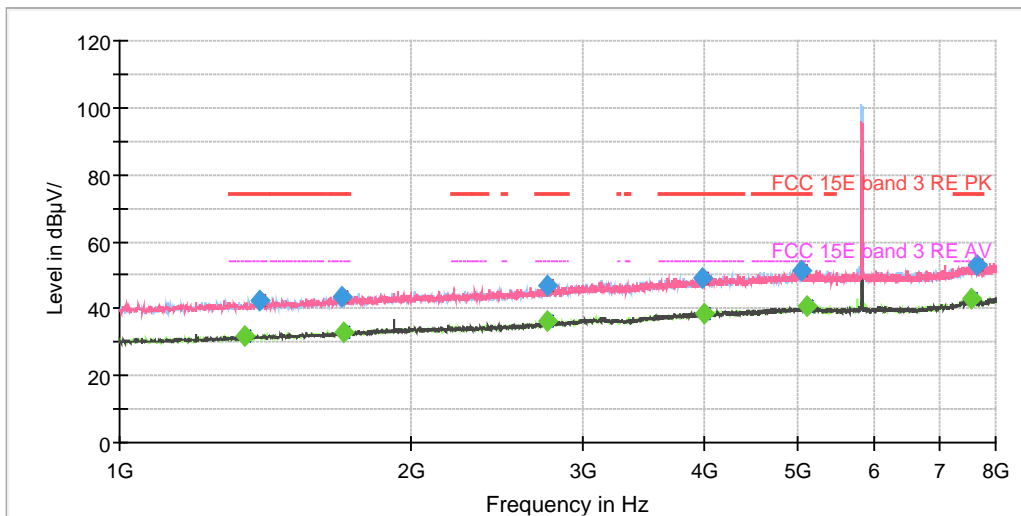

Note: The signal beyond the limit is carrier.
Radiates Emission from 1GHz to 8GHz

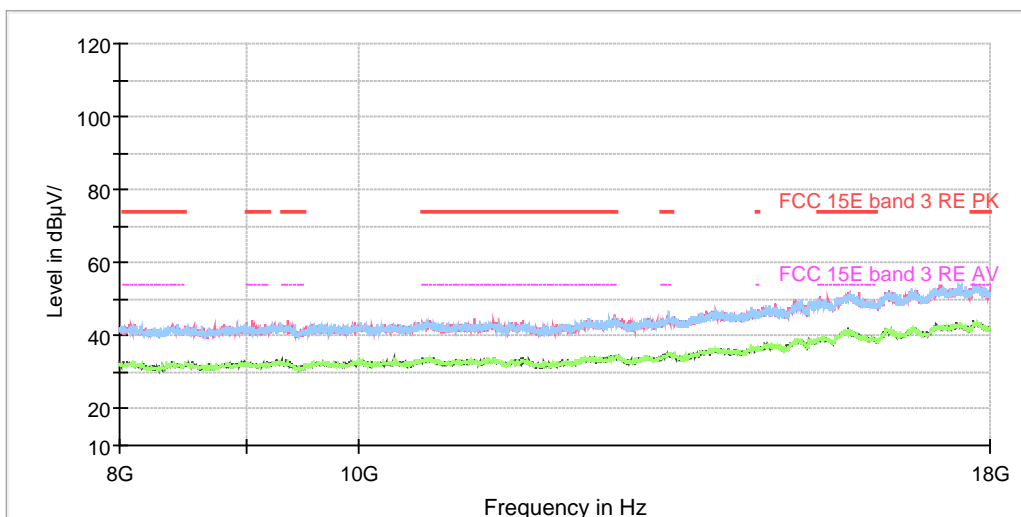

Radiates Emission from 8GHz to 18GHz



Frequency (MHz)	MaxPeak (dB μ V/m)	Average (dB μ V/m)	Height (cm)	Pol	Azimuth (deg)	Corr. (dB/m)	Margin (dB)	Limit (dB μ V/m)
1346.500000	---	32.03	200.0	V	120.0	-6.8	21.97	54.00
1395.500000	42.44	---	100.0	V	25.0	-6.5	31.56	74.00
1693.000000	43.40	---	200.0	H	209.0	-4.9	30.60	74.00
1701.750000	---	33.13	200.0	H	321.0	-4.8	20.87	54.00
2760.500000	---	36.08	100.0	V	11.0	-0.1	17.92	54.00
2764.875000	46.91	---	200.0	H	293.0	-0.1	27.09	74.00
3981.125000	49.36	---	100.0	V	187.0	4.3	24.64	74.00
3997.750000	---	38.76	200.0	H	356.0	4.4	15.24	54.00
5047.750000	51.08	---	100.0	V	154.0	6.7	22.92	74.00
5118.625000	---	40.75	100.0	V	216.0	6.8	13.25	54.00
7550.250000	---	43.24	100.0	H	149.0	10.3	10.76	54.00
7644.750000	53.10	---	100.0	V	291.0	10.3	20.90	74.00

Remark: 1. Correction Factor = Antenna factor+ Insertion loss (cable loss + amplifier gain)

802.11n (HT40) CH38

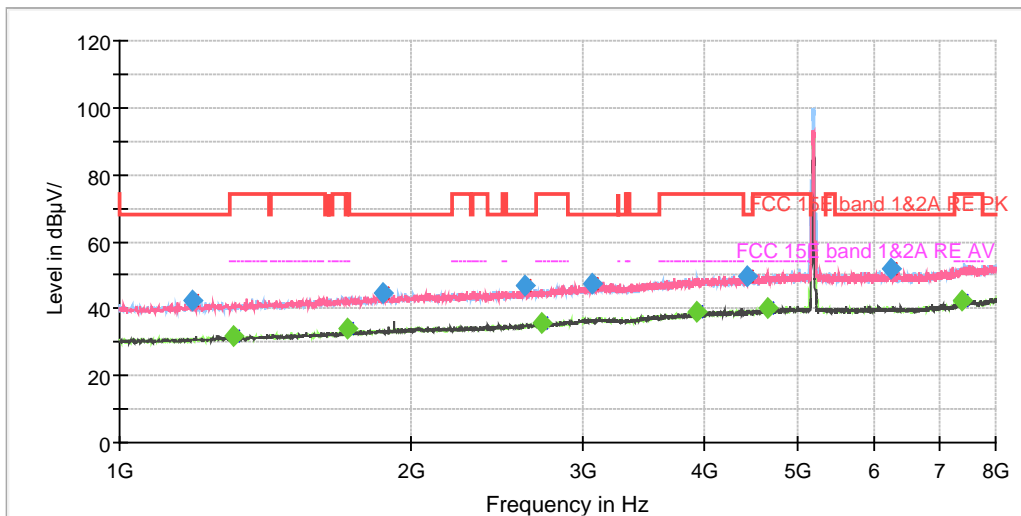

Note: The signal beyond the limit is carrier.
Radiates Emission from 1GHz to 8GHz

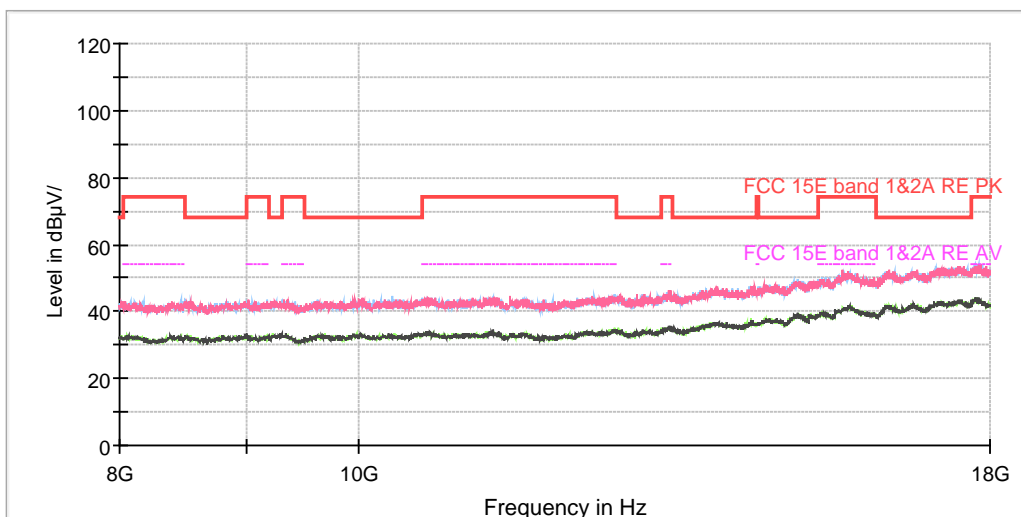

Radiates Emission from 8GHz to 18GHz



Frequency (MHz)	MaxPeak (dB μ V/m)	Average (dB μ V/m)	Height (cm)	Pol	Azimuth (deg)	Corr. (dB/m)	Margin (dB)	Limit (dB μ V/m)
1189.000000	42.56	---	100.0	V	285.0	-7.7	25.64	68.20
1313.250000	---	31.54	100.0	H	356.0	-7.0	22.46	54.00
1720.125000	---	33.97	100.0	V	274.0	-4.7	20.03	54.00
1869.750000	44.38	---	200.0	V	72.0	-3.9	23.82	68.20
2616.125000	46.88	---	100.0	H	16.0	-0.8	21.32	68.20
2726.375000	---	35.95	200.0	V	40.0	-0.3	18.05	54.00
3067.625000	47.43	---	100.0	V	316.0	1.6	20.77	68.20
3933.875000	---	39.25	100.0	V	12.0	4.3	14.75	54.00
4441.375000	49.75	---	100.0	V	295.0	5.1	18.45	68.20
4656.625000	---	40.28	100.0	V	198.0	5.7	13.72	54.00
6250.000000	51.91	---	100.0	H	152.0	8.5	16.29	68.20
7396.250000	---	42.33	200.0	H	208.0	10.0	11.67	54.00

Remark: 1. Correction Factor = Antenna factor+ Insertion loss (cable loss + amplifier gain)

802.11n (HT40) CH46

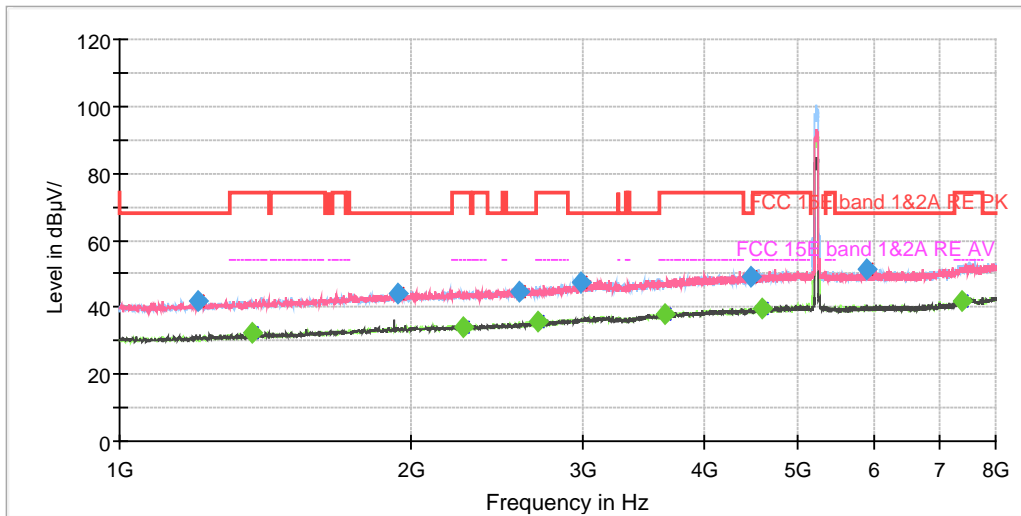

Note: The signal beyond the limit is carrier.
Radiates Emission from 1GHz to 8GHz

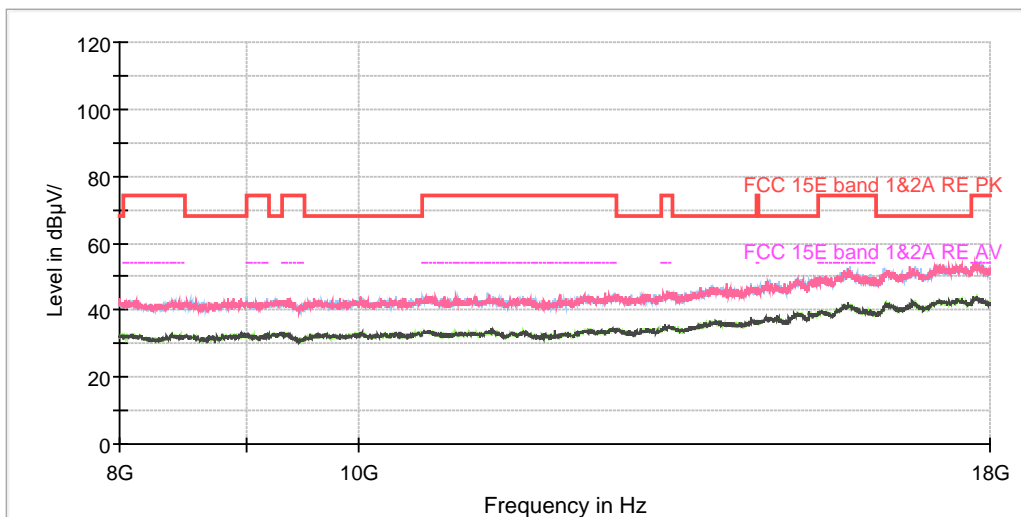

Radiates Emission from 8GHz to 18GHz



Frequency (MHz)	MaxPeak (dB μ V/m)	Average (dB μ V/m)	Height (cm)	Pol	Azimuth (deg)	Corr. (dB/m)	Margin (dB)	Limit (dB μ V/m)
1205.625000	41.93	---	200.0	H	220.0	-7.6	26.27	68.20
1369.250000	---	32.10	200.0	V	62.0	-6.6	21.90	54.00
1937.125000	44.28	---	200.0	H	231.0	-3.5	23.92	68.20
2256.500000	---	34.25	200.0	V	37.0	-2.3	19.75	54.00
2583.750000	44.69	---	200.0	H	18.0	-0.9	23.51	68.20
2705.375000	---	35.91	100.0	V	82.0	-0.4	18.09	54.00
2986.250000	47.22	---	200.0	H	143.0	1.3	20.98	68.20
3642.500000	---	38.14	200.0	V	161.0	3.3	15.86	54.00
4478.125000	49.13	---	100.0	H	136.0	5.1	19.07	68.20
4596.250000	---	39.74	100.0	V	191.0	5.5	14.26	54.00
5881.625000	51.28	---	100.0	H	157.0	8.0	16.92	68.20
7398.000000	---	41.99	200.0	H	18.0	10.0	12.01	54.00

Remark: 1. Correction Factor = Antenna factor+ Insertion loss (cable loss + amplifier gain)

802.11n (HT40) CH54

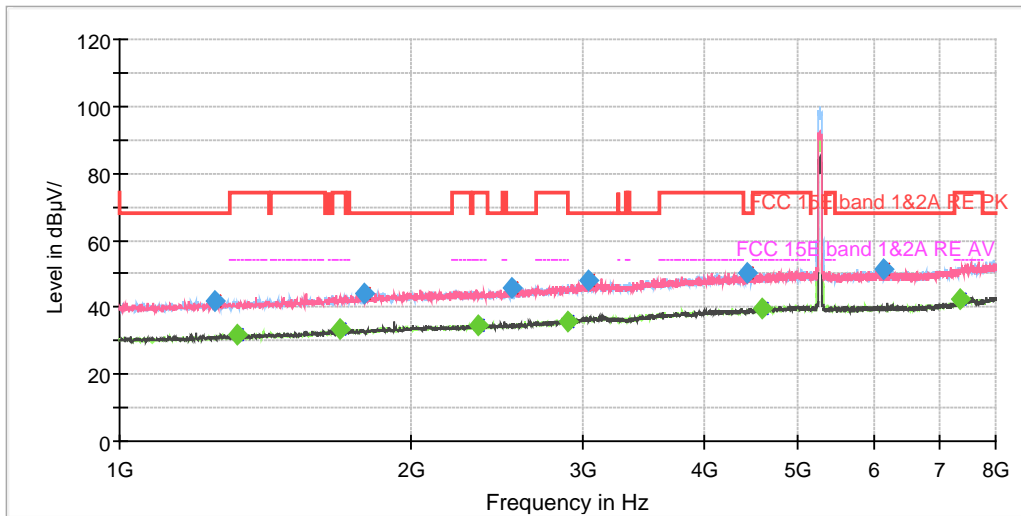

Note: The signal beyond the limit is carrier.
Radiates Emission from 1GHz to 8GHz

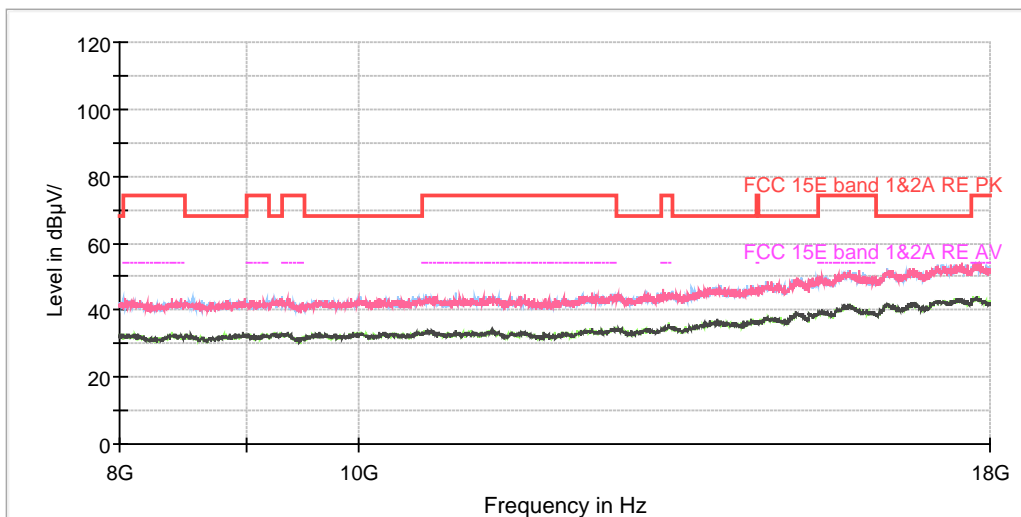

Radiates Emission from 8GHz to 18GHz



Frequency (MHz)	MaxPeak (dB μ V/m)	Average (dB μ V/m)	Height (cm)	Pol	Azimuth (deg)	Corr. (dB/m)	Margin (dB)	Limit (dB μ V/m)
1253.750000	41.94	---	100.0	V	299.0	-7.3	26.26	68.20
1323.750000	---	31.64	100.0	V	311.0	-6.9	22.36	54.00
1688.625000	---	33.27	200.0	H	74.0	-4.9	20.73	54.00
1791.000000	44.37	---	100.0	V	307.0	-4.3	23.83	68.20
2337.875000	---	34.82	200.0	V	161.0	-1.9	19.18	54.00
2537.375000	46.04	---	200.0	H	177.0	-1.2	22.16	68.20
2896.125000	---	35.99	100.0	V	83.0	0.8	18.01	54.00
3044.000000	48.17	---	100.0	V	226.0	1.6	20.03	68.20
4428.250000	50.18	---	200.0	H	244.0	5.1	18.02	68.20
4587.500000	---	39.75	200.0	H	0.0	5.5	14.25	54.00
6128.375000	51.33	---	200.0	V	289.0	8.2	16.87	68.20
7342.000000	---	42.62	200.0	V	153.0	10.0	11.38	54.00

Remark: 1. Correction Factor = Antenna factor+ Insertion loss (cable loss + amplifier gain)

802.11n (HT40) CH2

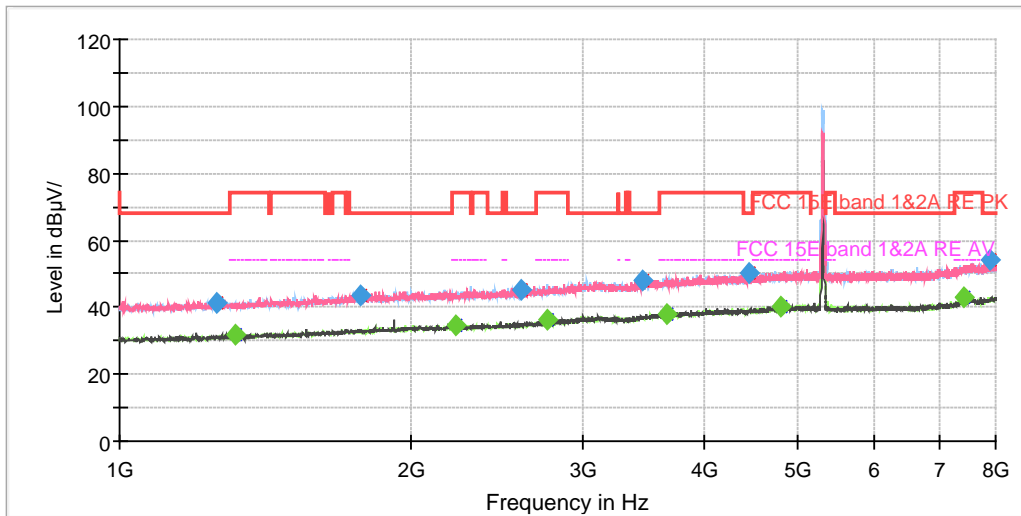

Note: The signal beyond the limit is carrier.
Radiates Emission from 1GHz to 8GHz

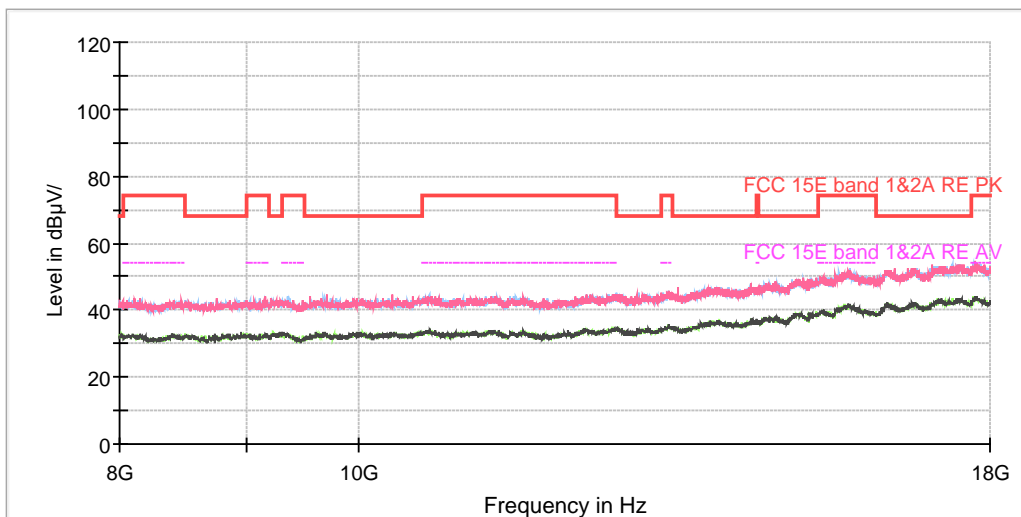

Radiates Emission from 8GHz to 18GHz



Frequency (MHz)	MaxPeak (dB μ V/m)	Average (dB μ V/m)	Height (cm)	Pol	Azimuth (deg)	Corr. (dB/m)	Margin (dB)	Limit (dB μ V/m)
1259.000000	41.44	---	200.0	V	54.0	-7.3	26.76	68.20
1317.625000	---	31.58	200.0	V	0.0	-7.0	22.42	54.00
1769.125000	43.57	---	200.0	V	341.0	-4.5	24.63	68.20
2224.125000	---	34.41	100.0	V	213.0	-2.3	19.59	54.00
2595.125000	45.28	---	200.0	V	260.0	-0.9	22.92	68.20
2759.625000	---	36.16	100.0	V	12.0	-0.1	17.84	54.00
3457.000000	48.06	---	200.0	V	41.0	2.6	20.14	68.20
3668.750000	---	38.08	100.0	H	29.0	3.5	15.92	54.00
4458.000000	50.24	---	200.0	H	318.0	5.1	17.96	68.20
4815.000000	---	40.34	100.0	V	88.0	6.1	13.66	54.00
7426.875000	---	42.74	200.0	H	329.0	10.0	11.26	54.00
7906.375000	54.10	---	200.0	V	172.0	10.5	14.10	68.20

Remark: 1. Correction Factor = Antenna factor+ Insertion loss (cable loss + amplifier gain)

802.11n (HT40) CH102

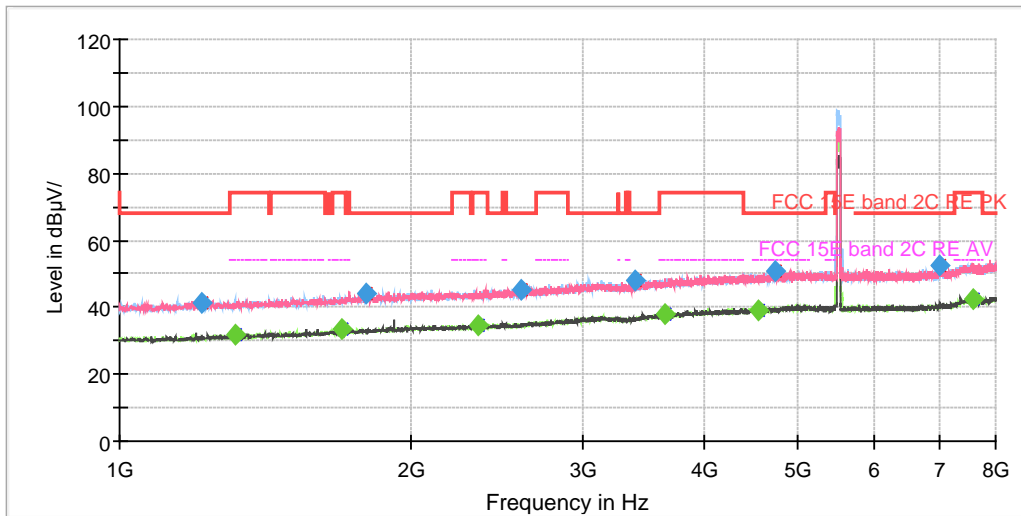

Note: The signal beyond the limit is carrier.
Radiates Emission from 1GHz to 8GHz

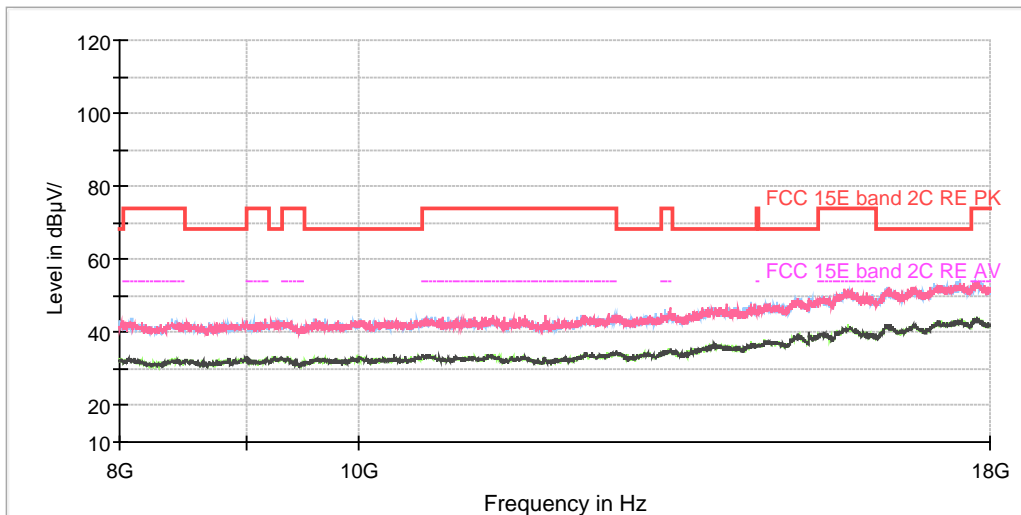

Radiates Emission from 8GHz to 18GHz



Frequency (MHz)	MaxPeak (dB μ V/m)	Average (dB μ V/m)	Height (cm)	Pol	Azimuth (deg)	Corr. (dB/m)	Margin (dB)	Limit (dB μ V/m)
1215.250000	41.54	---	200.0	H	329.0	-7.5	26.66	68.20
1315.875000	---	31.58	100.0	V	263.0	-7.0	22.42	54.00
1691.250000	---	33.23	200.0	H	161.0	-4.9	20.77	54.00
1793.625000	43.89	---	100.0	V	328.0	-4.3	24.31	68.20
2342.250000	---	34.77	100.0	H	141.0	-1.9	19.23	54.00
2589.875000	45.23	---	200.0	V	278.0	-0.9	22.97	68.20
3401.000000	48.08	---	200.0	V	17.0	2.1	20.12	68.20
3646.000000	---	38.13	200.0	V	45.0	3.4	15.87	54.00
4556.875000	---	39.30	100.0	H	101.0	5.3	14.70	54.00
4731.875000	50.85	---	100.0	H	23.0	5.9	17.35	68.20
7013.000000	52.31	---	200.0	V	53.0	9.3	15.89	68.20
7582.625000	---	42.63	200.0	H	0.0	10.3	11.37	54.00

Remark: 1. Correction Factor = Antenna factor+ Insertion loss (cable loss + amplifier gain)

802.11n (HT40) CH118

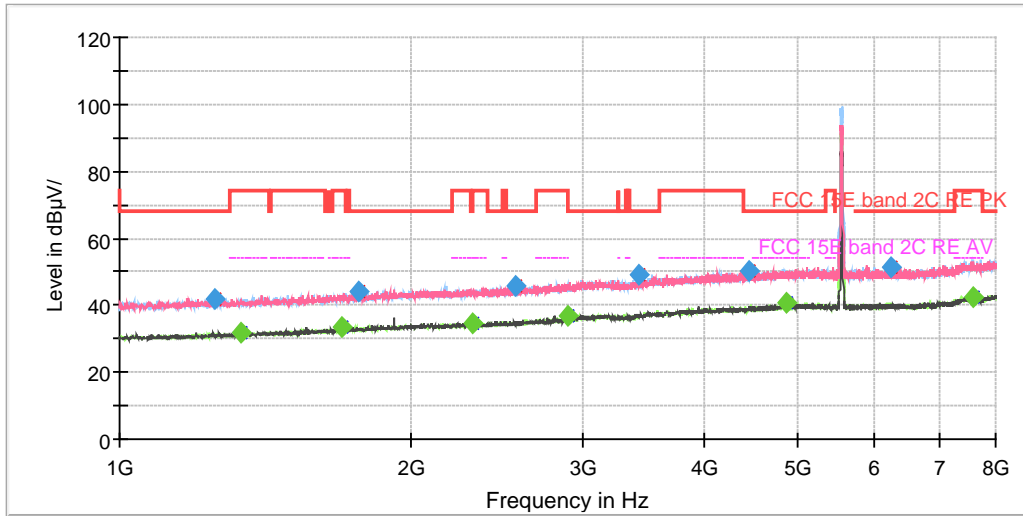

Note: The signal beyond the limit is carrier.
Radiates Emission from 1GHz to 8GHz

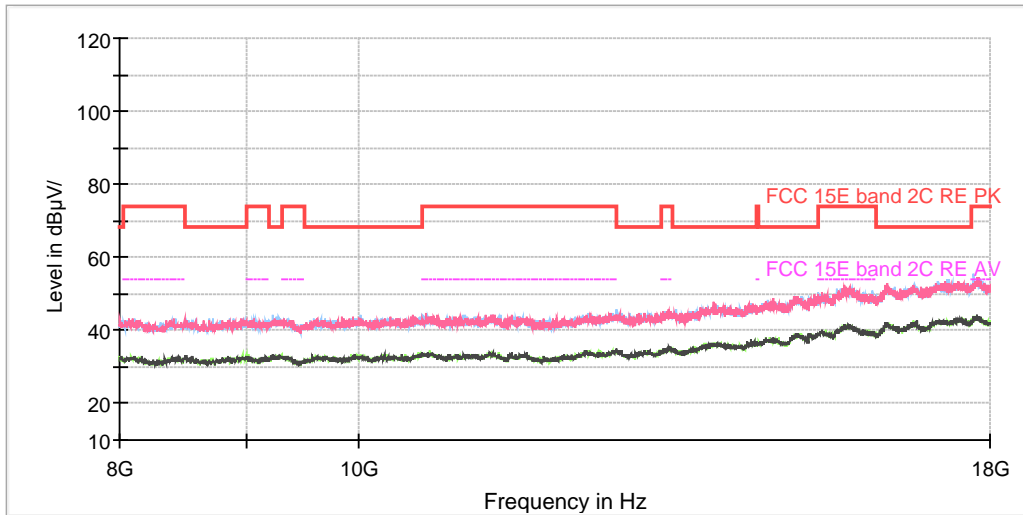

Radiates Emission from 8GHz to 18GHz



Frequency (MHz)	MaxPeak (dB μ V/m)	Average (dB μ V/m)	Height (cm)	Pol	Azimuth (deg)	Corr. (dB/m)	Margin (dB)	Limit (dB μ V/m)
1256.375000	41.73	---	200.0	H	234.0	-7.3	26.47	68.20
1333.375000	---	31.63	200.0	V	34.0	-6.9	22.37	54.00
1695.625000	---	33.22	200.0	V	21.0	-4.9	20.78	54.00
1762.125000	44.32	---	200.0	V	109.0	-4.5	23.88	68.20
2314.250000	---	34.39	100.0	H	13.0	-2.0	19.61	54.00
2558.375000	45.86	---	200.0	H	317.0	-1.0	22.34	68.20
2897.000000	---	36.56	200.0	V	260.0	0.8	17.44	54.00
3426.375000	49.18	---	100.0	H	72.0	2.3	19.02	68.20
4454.500000	50.34	---	200.0	H	213.0	5.1	17.86	68.20
4863.125000	---	40.47	200.0	V	4.0	6.3	13.53	54.00
6250.000000	51.51	---	100.0	V	116.0	8.5	16.69	68.20
7580.000000	---	42.49	200.0	H	259.0	10.3	11.51	54.00

Remark: 1. Correction Factor = Antenna factor+ Insertion loss (cable loss + amplifier gain)

802.11n (HT40) CH134

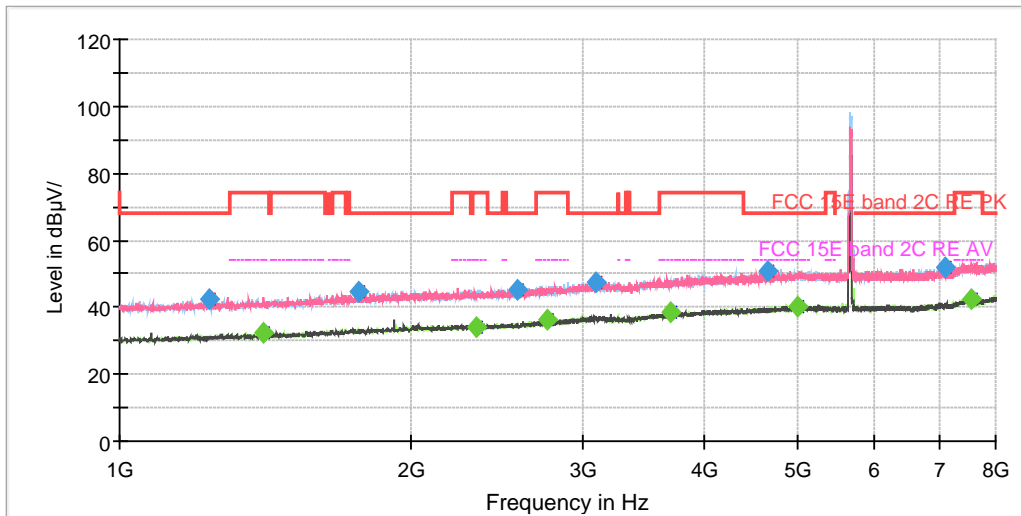

Note: The signal beyond the limit is carrier.
Radiates Emission from 1GHz to 8GHz

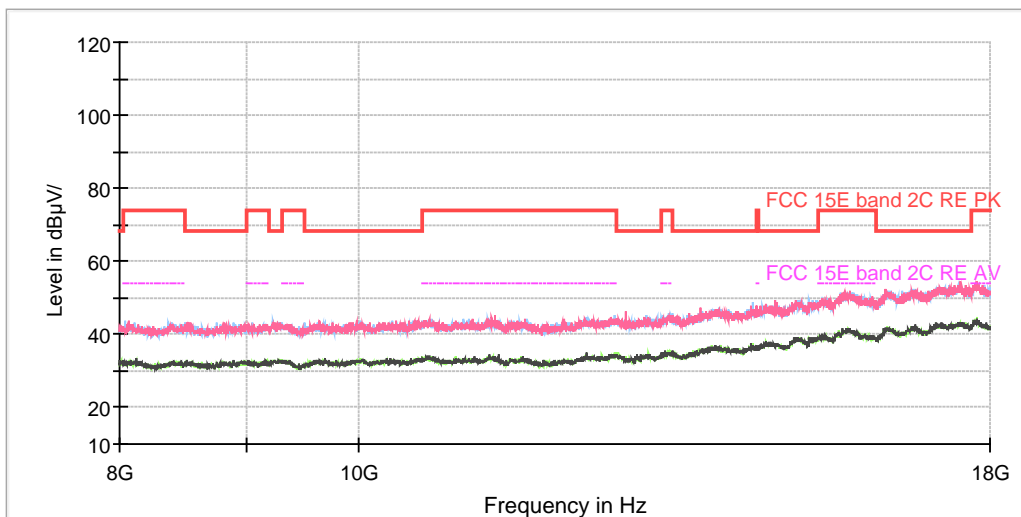

Radiates Emission from 8GHz to 18GHz



Frequency (MHz)	MaxPeak (dB μ V/m)	Average (dB μ V/m)	Height (cm)	Pol	Azimuth (deg)	Corr. (dB/m)	Margin (dB)	Limit (dB μ V/m)
1238.000000	42.57	---	200.0	V	297.0	-7.4	25.63	68.20
1406.000000	---	32.61	200.0	V	89.0	-6.4	21.39	54.00
1763.875000	44.79	---	100.0	V	25.0	-4.5	23.41	68.20
2331.750000	---	34.32	200.0	H	347.0	-1.9	19.68	54.00
2568.875000	45.33	---	100.0	H	191.0	-0.9	22.87	68.20
2759.625000	---	36.16	100.0	V	347.0	-0.1	17.84	54.00
3100.000000	47.70	---	200.0	V	1.0	1.8	20.50	68.20
3695.000000	---	38.66	100.0	V	200.0	3.5	15.34	54.00
4665.375000	50.89	---	100.0	V	354.0	5.7	17.31	68.20
5002.250000	---	40.28	100.0	H	32.0	6.7	13.72	54.00
7083.000000	51.92	---	100.0	H	49.0	9.4	16.28	68.20
7536.250000	---	42.47	100.0	H	240.0	10.2	11.53	54.00

Remark: 1. Correction Factor = Antenna factor+ Insertion loss (cable loss + amplifier gain)

802.11n (HT40) CH151

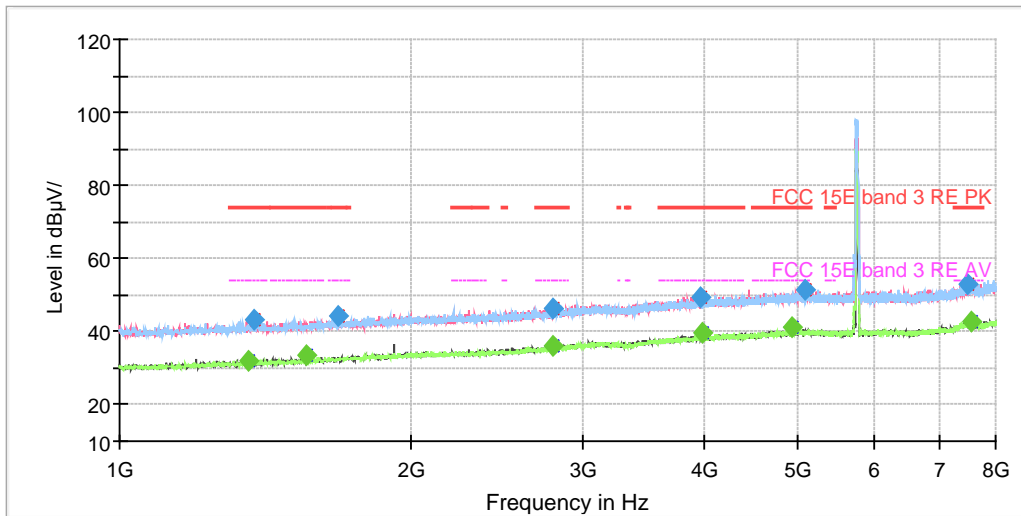

Note: The signal beyond the limit is carrier.
Radiates Emission from 1GHz to 8GHz

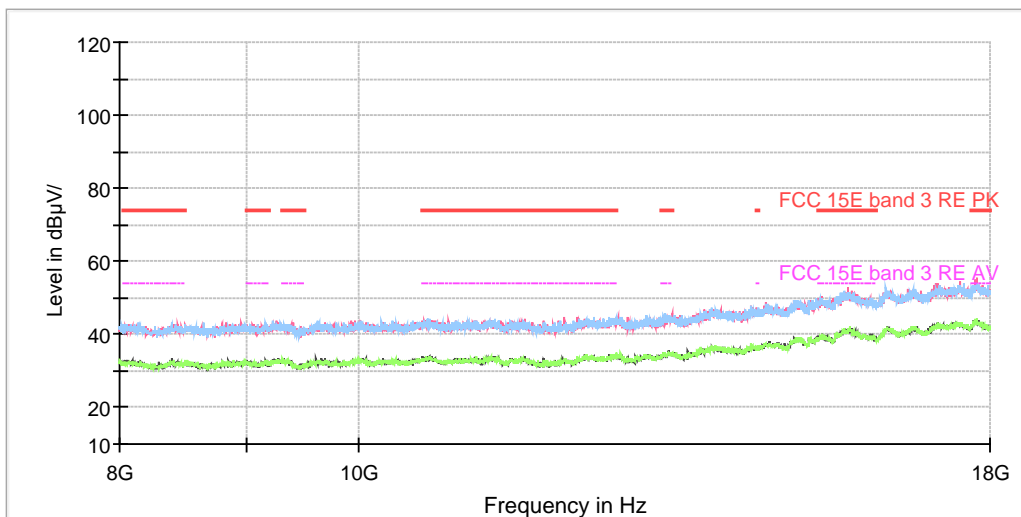

Radiates Emission from 8GHz to 18GHz

Frequency (MHz)	MaxPeak (dB μ V/m)	Average (dB μ V/m)	Height (cm)	Pol	Azimuth (deg)	Corr. (dB/m)	Margin (dB)	Limit (dB μ V/m)
1358.750000	---	31.99	100.0	H	41.0	-6.7	22.01	54.00
1373.625000	43.05	---	200.0	H	0.0	-6.6	30.95	74.00
1560.000000	---	33.38	200.0	V	312.0	-5.6	20.63	54.00
1680.750000	44.36	---	100.0	H	290.0	-4.9	29.64	74.00
2799.000000	---	36.29	200.0	H	65.0	0.2	17.71	54.00
2802.500000	46.21	---	200.0	V	262.0	0.2	27.79	74.00
3963.625000	49.59	---	100.0	H	0.0	4.3	24.41	74.00
3993.375000	---	39.46	100.0	V	166.0	4.3	14.54	54.00
4926.125000	---	40.97	200.0	V	215.0	6.4	13.03	54.00
5099.375000	51.42	---	200.0	H	32.0	6.9	22.58	74.00
7480.250000	52.94	---	200.0	H	223.0	10.2	21.06	74.00
7545.875000	---	42.90	200.0	H	29.0	10.3	11.10	54.00

Remark: 1. Correction Factor = Antenna factor+ Insertion loss (cable loss + amplifier gain)

802.11n (HT40) CH159

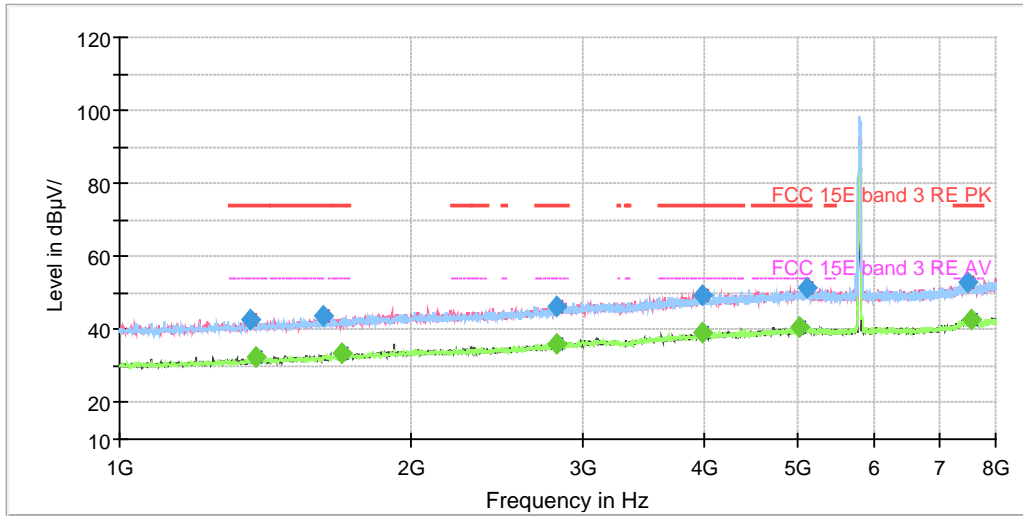

Note: The signal beyond the limit is carrier.
Radiates Emission from 1GHz to 8GHz

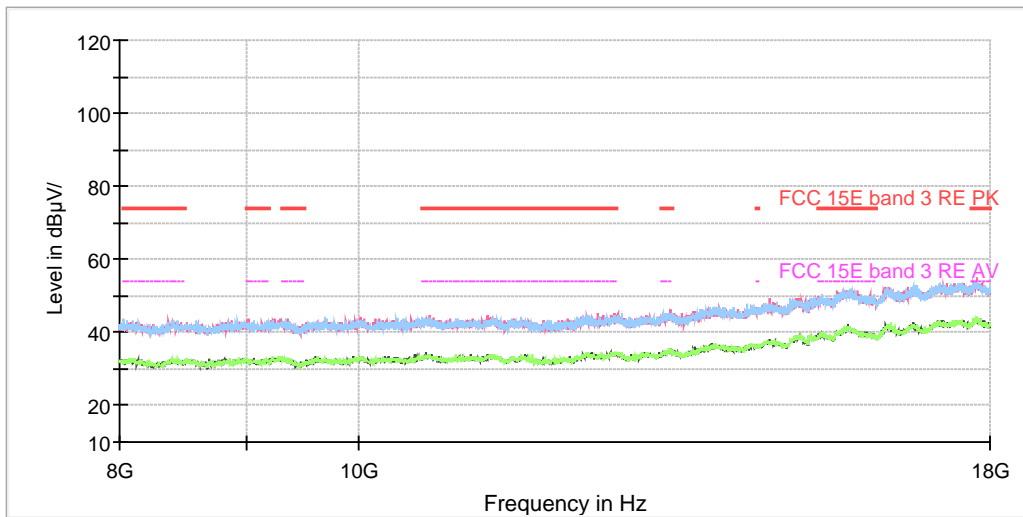

Radiates Emission from 8GHz to 18GHz



Frequency (MHz)	MaxPeak (dB μ V/m)	Average (dB μ V/m)	Height (cm)	Pol	Azimuth (deg)	Corr. (dB/m)	Margin (dB)	Limit (dB μ V/m)
1365.750000	42.52	---	100.0	V	7.0	-6.7	31.48	74.00
1384.125000	---	32.27	200.0	V	319.0	-6.5	21.73	54.00
1622.125000	43.64	---	200.0	V	323.0	-5.3	30.36	74.00
1697.375000	---	33.40	200.0	V	287.0	-4.9	20.60	54.00
2820.000000	---	36.02	100.0	V	341.0	0.3	17.98	54.00
2825.250000	46.37	---	200.0	H	128.0	0.3	27.63	74.00
3981.125000	49.35	---	200.0	V	108.0	4.3	24.65	74.00
3987.250000	---	39.04	100.0	H	1.0	4.3	14.96	54.00
5014.500000	---	40.81	200.0	V	237.0	6.7	13.19	54.00
5114.250000	51.20	---	200.0	V	0.0	6.9	22.80	74.00
7477.625000	52.89	---	200.0	H	317.0	10.1	21.11	74.00
7551.125000	---	42.70	200.0	H	58.0	10.3	11.30	54.00

Remark: 1. Correction Factor = Antenna factor+ Insertion loss (cable loss + amplifier gain)

802.11ac (HT80) CH42

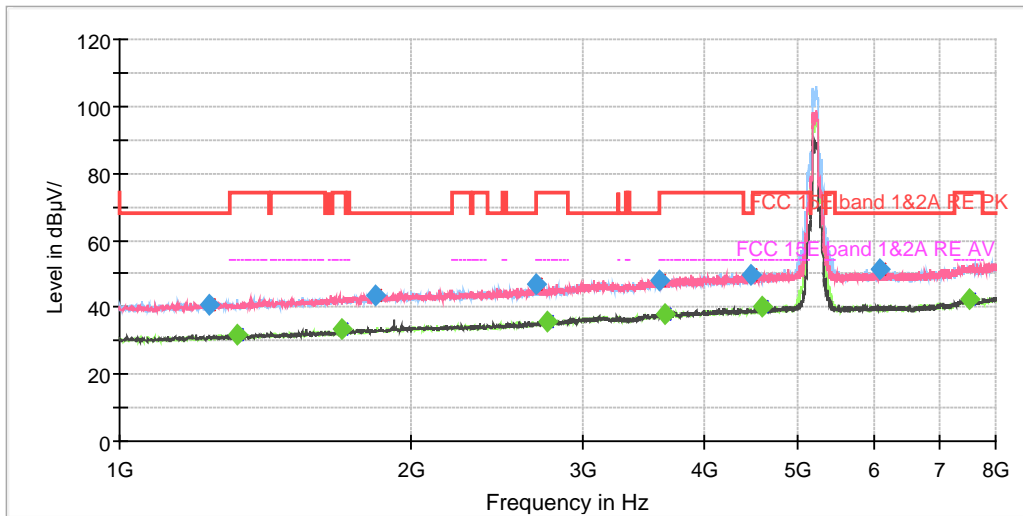

Note: The signal beyond the limit is carrier.
Radiates Emission from 1GHz to 8GHz

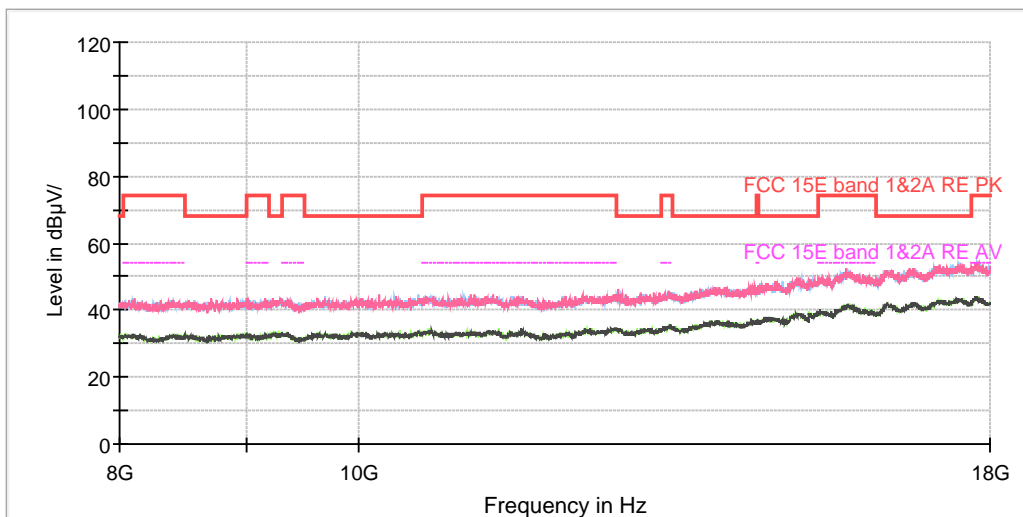

Radiates Emission from 8GHz to 18GHz



Frequency (MHz)	MaxPeak (dB μ V/m)	Average (dB μ V/m)	Height (cm)	Pol	Azimuth (deg)	Corr. (dB/m)	Margin (dB)	Limit (dB μ V/m)
1239.750000	41.01	---	100.0	V	97.0	-7.4	27.19	68.20
1319.375000	---	31.70	200.0	V	111.0	-6.9	22.30	54.00
1692.125000	---	33.32	200.0	V	128.0	-4.9	20.68	54.00
1835.625000	43.68	---	200.0	V	201.0	-4.0	24.52	68.20
2686.125000	46.85	---	100.0	V	254.0	-0.5	21.35	68.20
2760.500000	---	35.94	100.0	V	331.0	-0.1	18.06	54.00
3594.375000	48.05	---	200.0	V	307.0	3.3	20.15	68.20
3656.500000	---	38.15	200.0	H	268.0	3.4	15.85	54.00
4484.250000	49.72	---	200.0	H	219.0	5.1	18.48	68.20
4591.875000	---	39.91	200.0	V	297.0	5.5	14.09	54.00
6088.125000	51.54	---	100.0	H	166.0	8.1	16.66	68.20
7514.375000	---	42.52	200.0	V	23.0	10.2	11.48	54.00

Remark: 1. Correction Factor = Antenna factor+ Insertion loss (cable loss + amplifier gain)

802.11ac (HT80) CH58

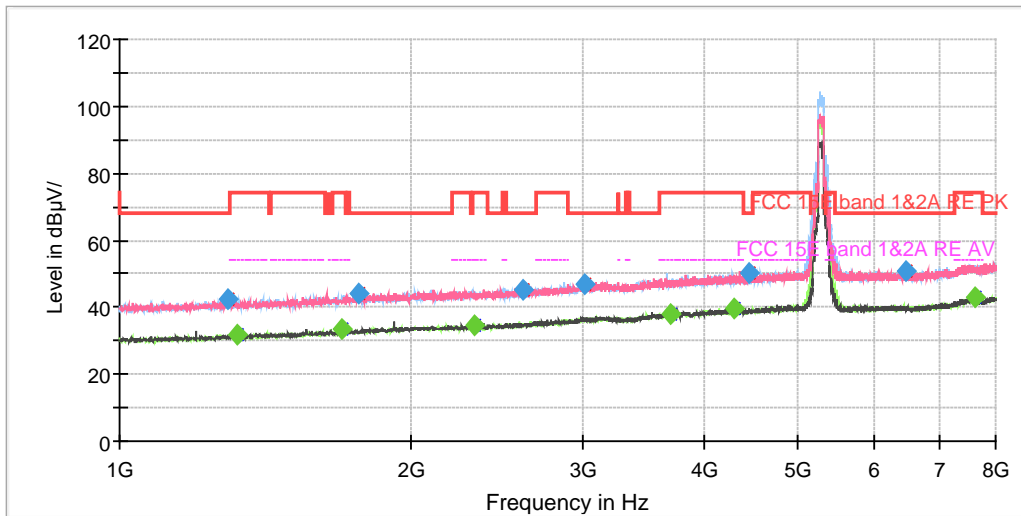

Note: The signal beyond the limit is carrier.
Radiates Emission from 1GHz to 8GHz

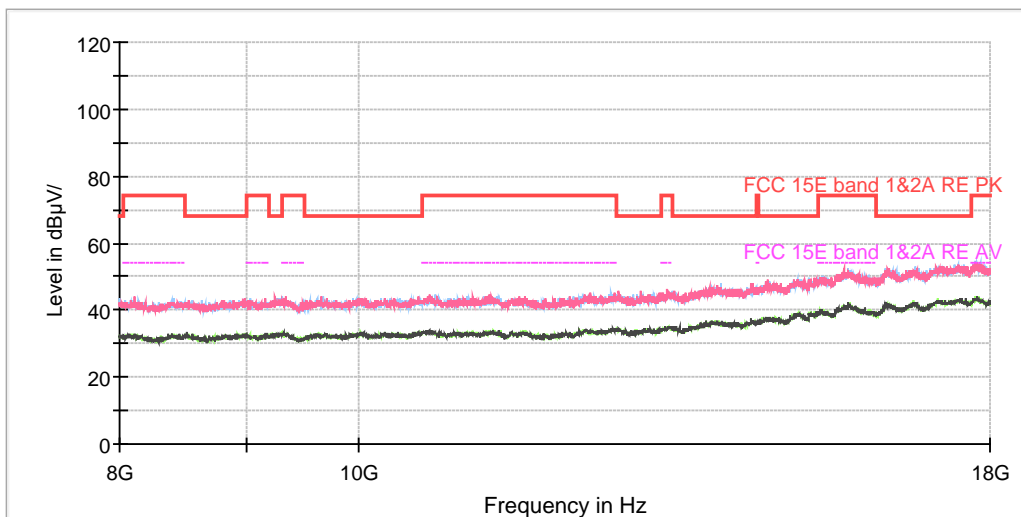

Radiates Emission from 8GHz to 18GHz



Frequency (MHz)	MaxPeak (dB μ V/m)	Average (dB μ V/m)	Height (cm)	Pol	Azimuth (deg)	Corr. (dB/m)	Margin (dB)	Limit (dB μ V/m)
1292.250000	42.55	---	200.0	H	73.0	-7.1	25.65	68.20
1323.750000	---	31.58	200.0	H	141.0	-6.9	22.42	54.00
1696.500000	---	33.22	200.0	V	148.0	-4.9	20.78	54.00
1766.500000	43.88	---	100.0	V	319.0	-4.5	24.32	68.20
2326.500000	---	34.82	200.0	V	207.0	-1.9	19.18	54.00
2610.000000	45.30	---	200.0	V	225.0	-0.8	22.90	68.20
3014.250000	47.07	---	100.0	V	198.0	1.5	21.13	68.20
3690.625000	---	38.14	100.0	H	119.0	3.5	15.86	54.00
4302.250000	---	39.40	200.0	V	158.0	4.9	14.60	54.00
4460.625000	50.11	---	200.0	V	275.0	5.1	18.09	68.20
6472.250000	51.03	---	200.0	V	317.0	8.6	17.17	68.20
7606.250000	---	42.70	100.0	V	308.0	10.3	11.30	54.00

Remark: 1. Correction Factor = Antenna factor+ Insertion loss (cable loss + amplifier gain)

802.11ac (HT80) CH106

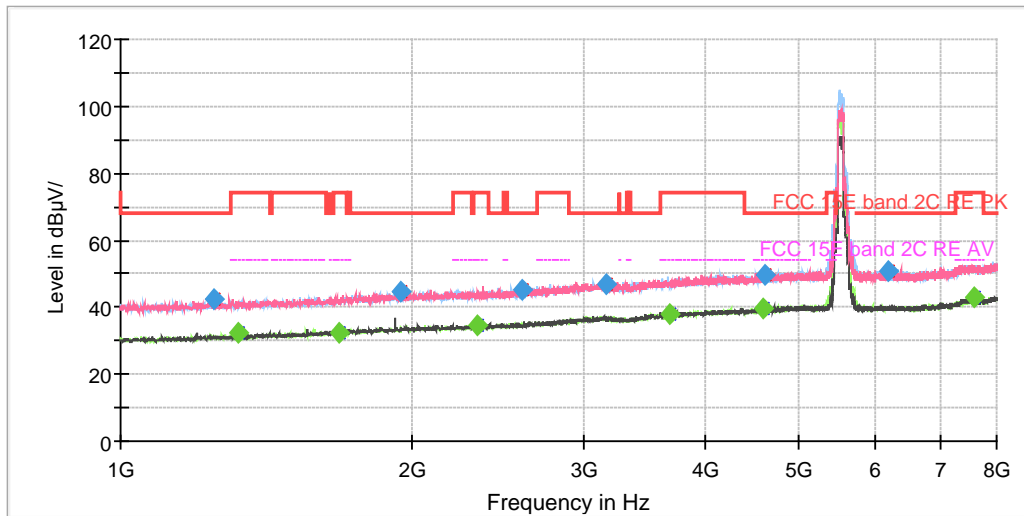

Note: The signal beyond the limit is carrier.
Radiates Emission from 1GHz to 8GHz

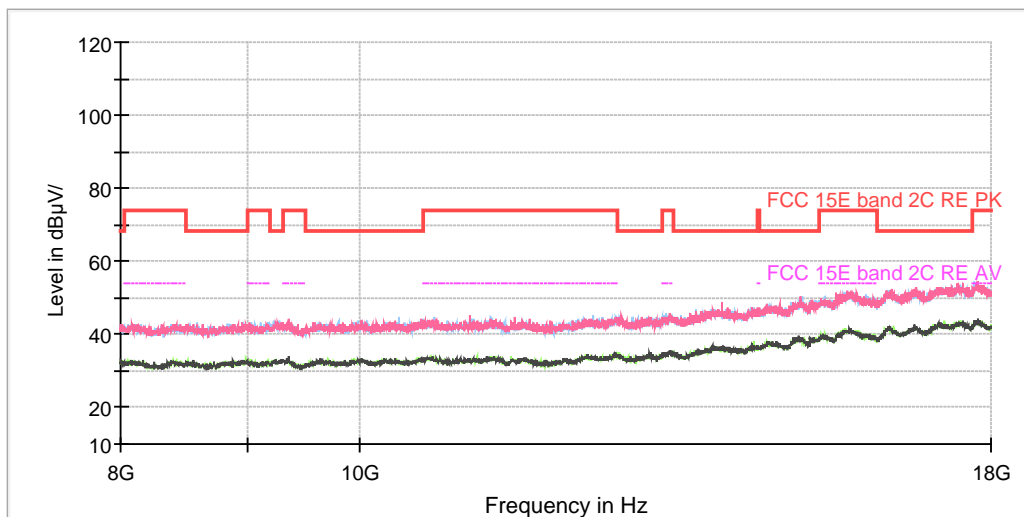

Radiates Emission from 8GHz to 18GHz



Frequency (MHz)	MaxPeak (dB μ V/m)	Average (dB μ V/m)	Height (cm)	Pol	Azimuth (deg)	Corr. (dB/m)	Margin (dB)	Limit (dB μ V/m)
1246.750000	42.33	---	100.0	V	222.0	-7.3	25.87	68.20
1319.375000	---	32.53	100.0	V	155.0	-6.9	21.47	54.00
1680.750000	---	32.63	200.0	H	324.0	-4.9	21.37	54.00
1948.500000	44.56	---	100.0	V	268.0	-3.5	23.64	68.20
2332.625000	---	34.37	200.0	H	215.0	-1.9	19.63	54.00
2597.750000	45.24	---	200.0	H	184.0	-0.9	22.96	68.20
3169.125000	47.15	---	200.0	V	223.0	1.9	21.05	68.20
3678.375000	---	38.13	200.0	V	245.0	3.5	15.87	54.00
4595.375000	---	39.76	200.0	V	252.0	5.5	14.24	54.00
4625.125000	49.62	---	100.0	V	130.0	5.6	18.58	68.20
6195.750000	50.70	---	200.0	H	36.0	8.5	17.50	68.20
7586.125000	---	42.83	200.0	V	127.0	10.3	11.17	54.00

Remark: 1. Correction Factor = Antenna factor+ Insertion loss (cable loss + amplifier gain)



802.11ac (HT80) CH155

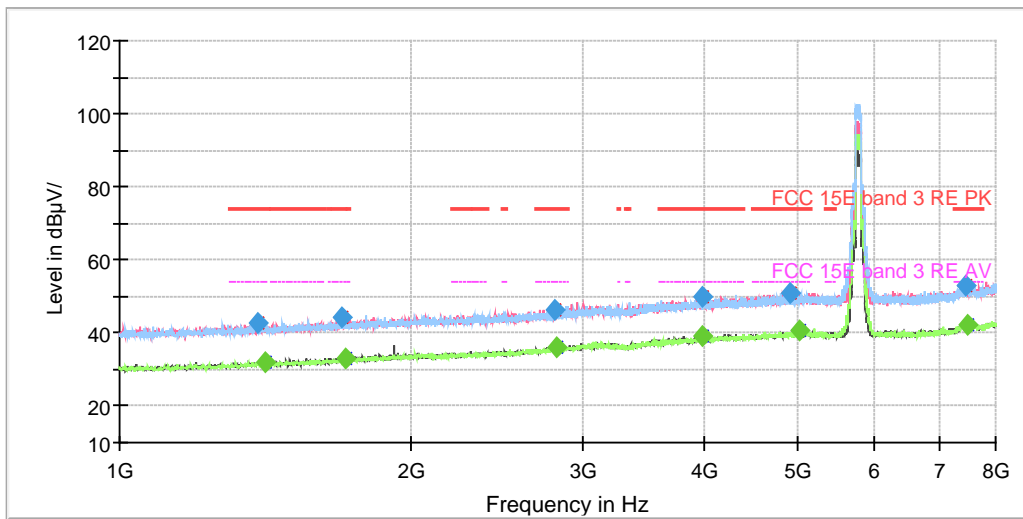

Note: The signal beyond the limit is carrier.
Radiates Emission from 1GHz to 8GHz

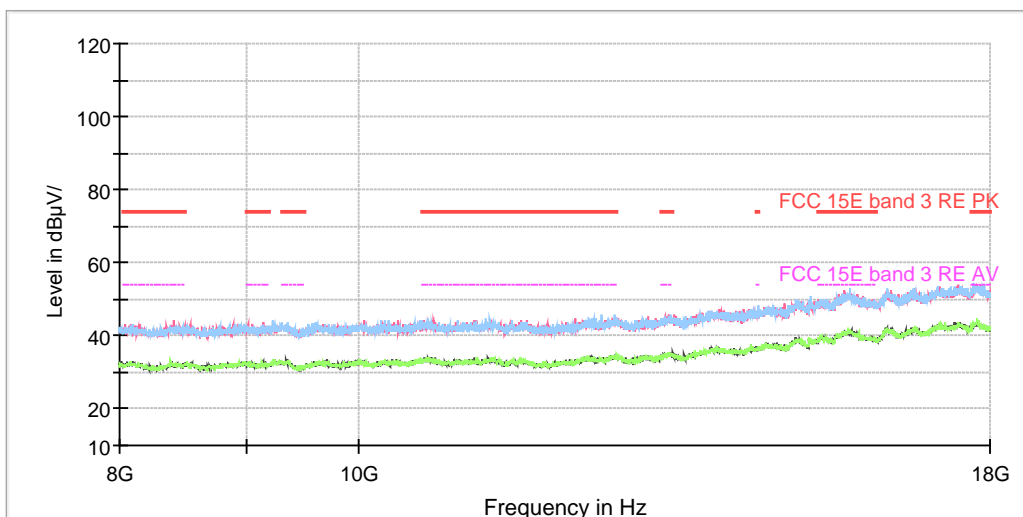

Radiates Emission from 8GHz to 18GHz



Frequency (MHz)	MaxPeak (dB μ V/m)	Average (dB μ V/m)	Height (cm)	Pol	Azimuth (deg)	Corr. (dB/m)	Margin (dB)	Limit (dB μ V/m)
1388.500000	42.95	---	100.0	V	154.0	-6.5	31.05	74.00
1413.000000	---	32.24	200.0	H	0.0	-6.4	21.76	54.00
1696.500000	44.14	---	100.0	V	73.0	-4.9	29.86	74.00
1707.000000	---	33.21	200.0	H	2.0	-4.8	20.79	54.00
2813.000000	46.44	---	200.0	H	9.0	0.2	27.56	74.00
2817.375000	---	35.90	100.0	V	268.0	0.3	18.10	54.00
3982.875000	---	39.02	100.0	H	238.0	4.3	14.98	54.00
3995.125000	49.66	---	100.0	V	27.0	4.4	24.34	74.00
4920.000000	51.17	---	200.0	H	27.0	6.4	22.83	74.00
5025.000000	---	40.49	100.0	V	304.0	6.7	13.51	54.00
7460.125000	53.23	---	200.0	V	109.0	10.1	20.77	74.00
7491.625000	---	42.48	200.0	H	164.0	10.2	11.52	54.00

Remark: 1. Correction Factor = Antenna factor+ Insertion loss (cable loss + amplifier gain)

5.3. Conducted Emission

Ambient condition

Temperature	Relative humidity	Pressure
23°C ~25°C	45%~50%	101.5kPa

Methods of Measurement

The EUT IS placed on a non-metallic table of 80cm height above the horizontal metal reference ground plane. During the test, the EUT was operating in its typical mode. The test method is according to ANSI C63.10-2013. Connect the AC power line of the EUT to the LISN Use EMI receiver to detect the average and Quasi-peak value. RBW is set to 9kHz, VBW is set to 30kHz The measurement result should include both L line and N line.

The test is in transmitting mode.

Test Setup

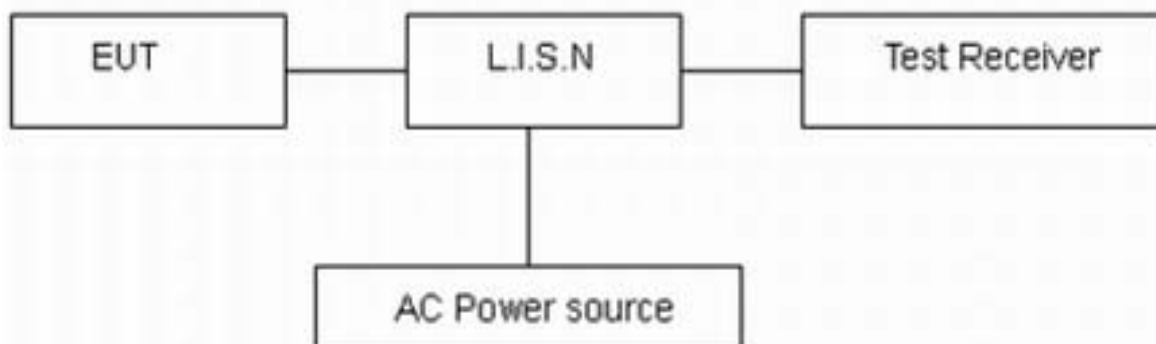

Note: AC Power source is used to change the voltage 110V/60Hz.

Limits

Frequency (MHz)	Conducted Limits(dBμV)	
	Quasi-peak	Average
0.15 - 0.5	66 to 56 *	56 to 46 *
0.5 - 5	56	46
5 - 30	60	50

*: Decreases with the logarithm of the frequency.

Measurement Uncertainty

The assessed measurement uncertainty to ensure 95% confidence level for the normal distribution is with the coverage factor $k = 1.96$, $U = 2.69$ dB.

Test Results:

Following plots, Blue trace uses the peak detection and Green trace uses the average detection. During the test, the Conducted Emission was performed in all modes with all channels, 802.11a CH116 are selected as the worst condition. The test data of the worst-case condition was recorded in this report.

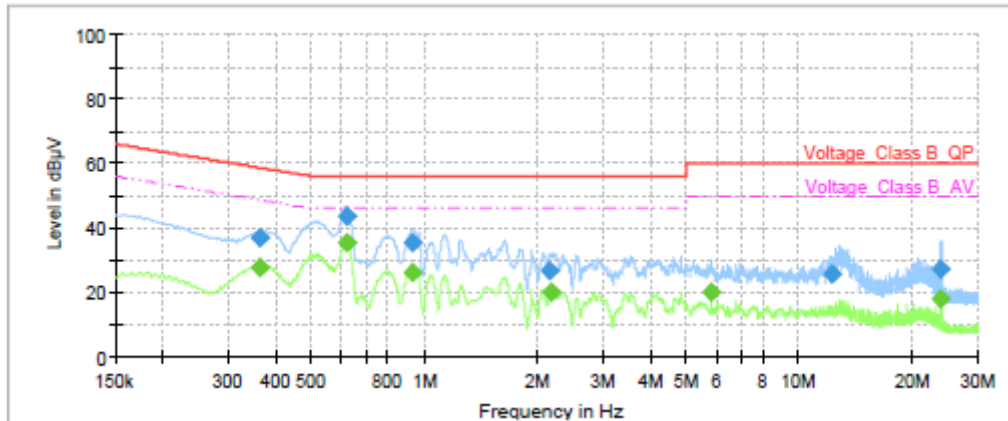

Conducted Emission from 150 KHz to 30 MHz

Frequency (MHz)	QuasiPeak (dBµV)	Average (dBµV)	Limit (dBµV)	Margin (dB)	Meas. Time (ms)	Bandwidth (kHz)	Line	Filter	Corr. (dB)
0.36	---	27.91	48.69	20.78	1000.0	9.000	L1	ON	19
0.36	37.14	---	58.69	21.55	1000.0	9.000	L1	ON	19
0.62	43.75	---	56.00	12.25	1000.0	9.000	L1	ON	19
0.62	---	35.51	46.00	10.49	1000.0	9.000	L1	ON	19
0.93	35.22	---	56.00	20.78	1000.0	9.000	L1	ON	19
0.93	---	26.24	46.00	19.76	1000.0	9.000	L1	ON	19
2.15	26.51	---	56.00	29.49	1000.0	9.000	L1	ON	19
2.18	---	20.01	46.00	25.99	1000.0	9.000	L1	ON	19
5.82	---	20.09	50.00	29.91	1000.0	9.000	L1	ON	19
12.29	25.76	---	60.00	34.24	1000.0	9.000	L1	ON	19
23.97	---	18.04	50.00	31.96	1000.0	9.000	L1	ON	20
23.97	27.23	---	60.00	32.77	1000.0	9.000	L1	ON	20

Remark: Correct factor=cable loss + LISN factor

L line

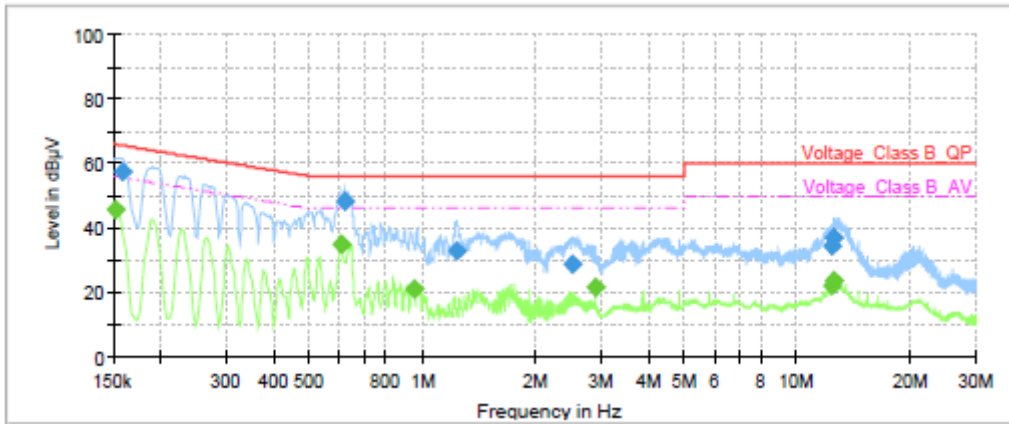

Conducted Emission from 150 KHz to 30 MHz

Frequency (MHz)	QuasiPeak (dBµV)	Average (dBµV)	Limit (dBµV)	Margin (dB)	Meas. Time (ms)	Bandwidth (kHz)	Line	Filter	Corr. (dB)
0.15	---	45.72	55.88	10.16	1000.0	9.000	N	ON	19
0.16	57.51	---	65.52	8.01	1000.0	9.000	N	ON	19
0.61	---	34.80	46.00	11.20	1000.0	9.000	N	ON	19
0.62	48.22	---	56.00	7.78	1000.0	9.000	N	ON	19
0.95	---	21.04	46.00	24.96	1000.0	9.000	N	ON	19
1.23	32.88	---	56.00	23.12	1000.0	9.000	N	ON	19
2.51	28.89	---	56.00	27.11	1000.0	9.000	N	ON	19
2.90	---	21.72	46.00	24.28	1000.0	9.000	N	ON	19
12.39	34.42	---	60.00	25.58	1000.0	9.000	N	ON	19
12.39	---	21.95	50.00	28.05	1000.0	9.000	N	ON	19
12.57	36.70	---	60.00	23.30	1000.0	9.000	N	ON	19
12.58	---	23.76	50.00	26.24	1000.0	9.000	N	ON	19

Remark: Correct factor=cable loss + LISN factor

N line



6. Main Test Instruments

Name	Manufacturer	Type	Serial Number	Calibration Date	Expiration Date
Spectrum Analyzer	R&S	FSV40	15195-01-00	2019-05-19	2020-05-18
EMI Test Receiver	R&S	ESCI	100948	2019-05-19	2020-05-18
Loop Antenna	SCHWARZBECK	FMZB1519	1519-047	2017-09-26	2019-09-25
TRILOG Broadband Antenna	SCHWARZBECK	VULB 9163	9163-201	2017-11-18	2019-11-17
Double Ridged Waveguide Horn Antenna	R&S	HF907	100126	2018-07-07	2020-07-06
Standard Gain Horn	ETS-Lindgren	3160-09	00102643	2018-06-20	2020-06-19
Standard Gain Horn	STEATITE	QSH-SL-26-40 -K-15	16779	2017-07-20	2020-07-19
Broadband Horn Antenna	SCHWARZBECK	BBHA 9120D	430	2018-07-07	2020-07-06
EMI Test Receiver	R&S	ESR	101667	2019-05-19	2020-05-18
LISN	R&S	ENV216	101171	2016-12-16	2019-12-15
Spectrum Analyzer	KEYSIGHT	N9020A	MY54420163	2018-12-16	2019-12-15
RF Cable	Agilent	SMA 15cm	0001	2019-09-13	2019-12-11
TEMPERATURE CHAMBER	WEISS	VT4002	582261194500 10	2018-12-16	2019-12-15
AV Power Meter	R&S	NRP	104306	2019-05-19	2020-05-18
Power Probe	R&S	NRP-Z21	104799	2019-05-19	2020-05-18
DC Power Supply	GWINSTEK	GPS-3030D	GEP882653	2019-05-19	2020-05-18
Software	R&S	EMC32	9.26.0	/	/

*****END OF REPORT *****