



RF TEST REPORT

Applicant Quectel Wireless Solutions Co., Ltd
FCC ID XMR201909EC21AUX
Product LTE Module
Brand Quectel
Model EC21-AUX, EC21-AUX MINIPCIE
Report No. R2108A0686-R1V1
Issue Date December 8, 2021

TA Technology (Shanghai) Co., Ltd. tested the above equipment in accordance with the requirements in **FCC CFR47 Part 2 (2020)/ FCC CFR 47 Part 22H (2020)**. The test results show that the equipment tested is capable of demonstrating compliance with the requirements as documented in this report.

Performed by: Peng Tao

Approved by: Kai Xu

TA Technology (Shanghai) Co., Ltd.

No.145, Jintang Rd, Tangzhen Industry Park, Pudong Shanghai, China

TEL: +86-021-50791141/2/3

FAX: +86-021-50791141/2/3-8000



TABLE OF CONTENT

1. Test Laboratory	4
1.1. Notes of the Test Report	4
1.2. Testing Location	4
2. General Description of Equipment under Test.....	5
2.1. Applicant and Manufacturer Information	5
2.2. General Information.....	5
3. Applied Standards.....	7
4. Test Configuration.....	8
5. Test Case Results.....	10
5.1. RF Power Output.....	10
5.2. Effective Radiated Power	17
5.3. Occupied Bandwidth	26
5.4. Band Edge Compliance.....	35
5.5. Peak-to-Average Power Ratio (PAPR)	58
5.6. Frequency Stability.....	60
5.7. Spurious Emissions at Antenna Terminals	66
5.8. Radiates Spurious Emission	110
6. Main Test Instruments	116
ANNEX A: The EUT Appearance	117
ANNEX B: Test Setup Photos	118
ANNEX C: Verify data	119
ANNEX D: Product Change Description	120

Summary of measurement results

No.	Test Case	Clause in FCC rules	Verdict
1	RF power output	2.1046	PASS
2	Effective Radiated Power	22.913(a)(5)	PASS
3	Occupied Bandwidth	2.1049	PASS
4	Band Edge Compliance	2.1051 / 22.917(a)	PASS
5	Peak-to-Average Power Ratio	22.913(d)/ KDB 971168 D01(5.7)	PASS
6	Frequency Stability	2.1055 / 22.355	PASS
7	Spurious Emissions at Antenna Terminals	2.1051 / 22.917(a)	PASS
8	Radiates Spurious Emission	2.1053 / 22.917 (a)	PASS
Date of Testing: (Original) August 19, 2019 ~October 10, 2019 (Variant) September 28, 2021~ December 1, 2021			
Note: PASS: The EUT complies with the essential requirements in the standard.			

EC21-AUX, EC21-AUX MINIPCIE (Report No.: R2108A0686-R1V1) is a variant model of EC21-AUX MINIPCIE (Report No.: R1908A0502-R1). There is only changed the Power Amplifier and Software Version of product.

Tested cases refer to the following table. Please refer to Appendix C for Verify data

Test Case	Original	Variant
RF Power Output and Effective Radiated Power	PASS	Retest(GSM850 /WCDMA Band V/ LTE band5)
Occupied Bandwidth	PASS	Verify the worst combination of each frequency band(GSM850 / WCDMA Band V/ LTE band5)
Band Edge Compliance	PASS	Verify the worst combination of each frequency band(GSM850 / WCDMA Band V/ LTE band5)
Peak-to-Average Power Ratio	PASS	Retest(GSM850 / WCDMA Band V/ LTE band 5)
Frequency Stability	PASS	Refer to the Original
Spurious Emissions at Antenna Terminals	PASS	Verify the worst combination of each frequency band(GSM850 / WCDMA Band V/ LTE band5)
Radiates Spurious Emission	PASS	Retest(GSM850 / WCDMA Band V/ LTE band 5)

The detailed product change description please refers to the Difference Declaration Letter.



1. Test Laboratory

1.1. Notes of the Test Report

This report shall not be reproduced in full or partial, without the written approval of **TA technology (shanghai) co., Ltd.** The results documented in this report apply only to the tested sample, under the conditions and modes of operation as described herein .Measurement Uncertainties were not taken into account and are published for informational purposes only. This report is written to support regulatory compliance of the applicable standards stated above.

1.2. Testing Location

Company: TA Technology (Shanghai) Co., Ltd.
Address: No.145, Jintang Rd, Tangzhen Industry Park, Pudong
City: Shanghai
Post code: 201201
Country: P. R. China
Contact: Xu Kai
Telephone: +86-021-50791141/2/3
Fax: +86-021-50791141/2/3-8000
Website: <http://www.ta-shanghai.com>
E-mail: xukai@ta-shanghai.com

2. General Description of Equipment under Test

2.1. Applicant and Manufacturer Information

Applicant	Quectel Wireless Solutions Co., Ltd
Applicant address	Building 5, Shanghai Business Park Phase III (Area B), No.1016 Tianlin Road, Minhang District, Shanghai, China 200233
Manufacturer	Quectel Wireless Solutions Co., Ltd
Manufacturer address	Building 5, Shanghai Business Park Phase III (Area B), No.1016 Tianlin Road, Minhang District, Shanghai, China 200233

2.2. General Information

EUT Description			
Model	EC21-AUX, EC21-AUX MINIPCIE		
IMEI	868450040001099		
Hardware Version	R2.0		
Software Version	EC21AUXGAR08A03M1G		
Power Supply	External power supply		
Antenna Type	The EUT don't have standard Antenna, The Antenna used for testing in this report is the after-market accessory (Dipole Antenna)		
Antenna Gain	4dBi		
Test Mode(s)	GSM 850; WCDMA Band V; LTE Band 5;		
Test Modulation	(GSM)GMSK, 8PSK; (WCDMA) BPSK, QPSK, 16QAM; (LTE)QPSK 16QAM;		
GPRS Multislot Class	33		
EGPRS Multislot Class	33		
HSDPA UE Category	24		
HSUPA UE Category	6		
DC-HSDPA UE Category	24		
HSPA+ UE Category	6		
LTE Category	1		
Maximum E.R.P.	GSM 850:	33.09dBm	
	WCDMA Band V:	24.31dBm	
	LTE Band 5:	24.76dBm	
Rated Power Supply Voltage	3.8V		
Extreme Voltage	Minimum: 3.3V Maximum: 4.3V		
Extreme Temperature	Lowest: -40°C Highest: +85°C		
Operating Frequency Range(s)	Band	Tx (MHz)	Rx (MHz)
	GSM850	824 ~ 849	869 ~ 894



	WCDMA Band V	824 ~ 849	869 ~ 894
	LTE Band 5	824 ~ 849	869 ~ 894
Note: The information of the EUT is declared by the manufacturer.			



3. Applied Standards

According to the specifications of the manufacturer, it must comply with the requirements of the following standards:

FCC CFR47 Part 2 (2018)

FCC CFR 47 Part 22H (2018)

ANSI C63.26 (2015)

KDB 971168 D01 Power Meas License Digital Systems v03r01

4. Test Configuration

Radiated measurements are performed by rotating the EUT in three different orthogonal test planes. EUT stand-up position (Z axis), lie-down position (X, Y axis). Receiver antenna polarization (horizontal and vertical), the worst emission was found in position (X axis, vertical polarization) and the worst case was recorded.

All mode and data rates and positions were investigated. Subsequently, only the worst case emissions are reported.

The following testing in GSM/WCDMA/LTE is set based on the maximum RF Output Power.

Test modes are chosen to be reported as the worst case configuration below:

Test items	Modes/Modulation	
	GSM 850	WCDMA Band V
RF power output	GPRS EGPRS	RMC HSDPA/HSUPA DC-HSDPA
Effective Radiated Power	GPRS(1Tx slot) EGPRS(1Tx slot)	RMC
Occupied Bandwidth	GPRS(1Tx slot) EGPRS(1Tx slot)	RMC
Band Edge Compliance	GPRS(1Tx slot) EGPRS(1Tx slot)	RMC
Peak-to-Average Power Ratio	GPRS(1Tx slot) EGPRS(1Tx slot)	RMC
Frequency Stability	GPRS(1Tx slot) EGPRS(1Tx slot)	RMC
Spurious Emissions at Antenna Terminals	GPRS(1Tx slot)	RMC
Radiates Spurious Emission	GPRS(1Tx slot)	RMC



Test modes are chosen as the worst case configuration below for LTE Band 5.

Test items	Bandwidth (MHz)				Modulation		RB			Test Channel		
	1.4	3	5	10	QPSK	16QAM	1	50%	100%	L	M	H
RF power output	O	O	O	O	O	O	O	O	O	O	O	O
Effective Isotropic Radiated power	O	O	O	O	O	O	O	O	O	O	O	O
Occupied Bandwidth	O	O	O	O	O	O	O	O	O	-	O	-
Band Edge Compliance	O	O	O	O	O	O	O	O	O	O	-	O
Peak-to-Average Power Ratio	O	O	O	O	O	O	O	O	O	O	O	O
Frequency Stability	O	O	O	O	O	O	O	O	O	O	O	O
Spurious Emissions at Antenna Terminals	O	O	O	O	O	-	O	O	O	O	O	O
Radiates Spurious Emission	O	-	O	O	O	-	O	-	-	-	O	-
Note	1. The mark "O" means that this configuration is chosen for testing. 2. The mark "-" means that this configuration is not testing.											

5. Test Case Results

5.1. RF Power Output

Ambient condition

Temperature	Relative humidity	Pressure
23°C ~25°C	45%~50%	101.5kPa

Methods of Measurement

During the process of the testing, The EUT is controlled by the Base Station Simulator to ensure max power transmission and proper modulation.

Test Setup

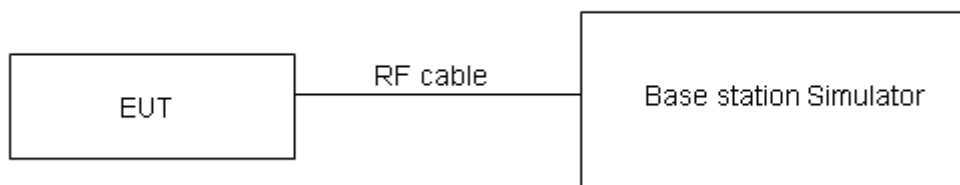

The loss between RF output port of the EUT and the input port of the tester has been taken into consideration.

Limits

No specific RF power output requirements in part 2.1046.

Measurement Uncertainty

The assessed measurement uncertainty to ensure 95% confidence level for the normal distribution is with the coverage factor $k = 2$, $U = 0.4$ dB.



Test Results

Band	Channel	PCL	Slot	Power (dBm)	Limit(dBm)	Verdict
GPRS850	128	5	1	32.24	38.5	PASS
GPRS850	128	5	2	32.07	38.5	PASS
GPRS850	128	5	3	29.60	38.5	PASS
GPRS850	128	5	4	28.74	38.5	PASS
GPRS850	190	5	1	32.17	38.5	PASS
GPRS850	190	5	2	31.66	38.5	PASS
GPRS850	190	5	3	29.57	38.5	PASS
GPRS850	190	5	4	28.36	38.5	PASS
GPRS850	251	5	1	32.15	38.5	PASS
GPRS850	251	5	2	31.61	38.5	PASS
GPRS850	251	5	3	29.48	38.5	PASS
GPRS850	251	5	4	28.25	38.5	PASS
EGPRS850	128	8	1	26.99	38.5	PASS
EGPRS850	128	8	2	26.11	38.5	PASS
EGPRS850	128	8	3	23.71	38.5	PASS
EGPRS850	128	8	4	22.45	38.5	PASS
EGPRS850	190	8	1	26.75	38.5	PASS
EGPRS850	190	8	2	25.80	38.5	PASS
EGPRS850	190	8	3	23.54	38.5	PASS
EGPRS850	190	8	4	22.29	38.5	PASS
EGPRS850	251	8	1	26.76	38.5	PASS
EGPRS850	251	8	2	25.60	38.5	PASS
EGPRS850	251	8	3	23.58	38.5	PASS
EGPRS850	251	8	4	22.09	38.5	PASS

Band	Channel	SubTest	Power(dBm)	Limit (dBm)	Verdict
Band V	4132	-	23.28	38.5	PASS
WCDMA Band V	4281	-	23.46	38.5	PASS
WCDMA Band V	4233	-	23.30	38.5	PASS
WCDMA Band V	4132	HSDPA_Sub0	23.02	38.5	PASS
WCDMA Band V	4132	HSDPA_Sub1	22.51	38.5	PASS
WCDMA Band V	4132	HSDPA_Sub2	22.50	38.5	PASS
WCDMA Band V	4132	HSDPA_Sub3	22.49	38.5	PASS
WCDMA Band V	4182	HSDPA_Sub0	23.02	38.5	PASS
WCDMA Band V	4182	HSDPA_Sub1	22.52	38.5	PASS
WCDMA Band V	4182	HSDPA_Sub2	22.52	38.5	PASS
WCDMA Band V	4182	HSDPA_Sub3	22.62	38.5	PASS



WCDMA Band V	4233	HSDPA_Sub0	22.98	38.5	PASS
WCDMA Band V	4233	HSDPA_Sub1	22.58	38.5	PASS
WCDMA Band V	4132	HSUPA_Sub1	22.68	38.5	PASS
WCDMA Band V	4132	HSUPA_Sub2	20.92	38.5	PASS
WCDMA Band V	4132	HSUPA_Sub3	22.12	38.5	PASS
WCDMA Band V	4132	HSUPA_Sub4	21.54	38.5	PASS
WCDMA Band V	4132	HSUPA_Sub5	22.88	38.5	PASS
WCDMA Band V	4182	HSUPA_Sub1	22.99	38.5	PASS
WCDMA Band V	4182	HSUPA_Sub2	21.10	38.5	PASS
WCDMA Band V	4182	HSUPA_Sub3	22.14	38.5	PASS
WCDMA Band V	4182	HSUPA_Sub4	21.75	38.5	PASS
WCDMA Band V	4182	HSUPA_Sub5	23.00	38.5	PASS
WCDMA Band V	4233	HSUPA_Sub1	22.59	38.5	PASS
WCDMA Band V	4233	HSUPA_Sub2	21.12	38.5	PASS
WCDMA Band V	4233	HSUPA_Sub3	22.25	38.5	PASS
WCDMA Band V	4233	HSUPA_Sub4	21.64	38.5	PASS
WCDMA Band V	4233	HSUPA_Sub5	23.01	38.5	PASS

Band	Bandwidth	Modulation	Channel	RB Configuration	Result (dBm)	Verdict
LTE Band 5	1.4MHz	QPSK	20407	1RB#0	23.55	PASS
LTE Band 5	1.4MHz	16QAM	20407	1RB#0	22.81	PASS
LTE Band 5	1.4MHz	QPSK	20407	1RB#2	23.86	PASS
LTE Band 5	1.4MHz	16QAM	20407	1RB#2	22.93	PASS
LTE Band 5	1.4MHz	QPSK	20407	1RB#5	23.79	PASS
LTE Band 5	1.4MHz	16QAM	20407	1RB#5	22.90	PASS
LTE Band 5	1.4MHz	QPSK	20407	3RB#0	23.44	PASS
LTE Band 5	1.4MHz	16QAM	20407	3RB#0	22.33	PASS
LTE Band 5	1.4MHz	QPSK	20407	3RB#1	23.40	PASS
LTE Band 5	1.4MHz	16QAM	20407	3RB#1	22.31	PASS
LTE Band 5	1.4MHz	QPSK	20407	3RB#3	23.43	PASS
LTE Band 5	1.4MHz	16QAM	20407	3RB#3	22.32	PASS
LTE Band 5	1.4MHz	QPSK	20407	6RB#0	22.34	PASS
LTE Band 5	1.4MHz	16QAM	20407	6RB#0	21.48	PASS
LTE Band 5	1.4MHz	QPSK	20525	1RB#0	23.57	PASS
LTE Band 5	1.4MHz	16QAM	20525	1RB#0	22.47	PASS
LTE Band 5	1.4MHz	QPSK	20525	1RB#2	23.81	PASS
LTE Band 5	1.4MHz	16QAM	20525	1RB#2	23.38	PASS
LTE Band 5	1.4MHz	QPSK	20525	1RB#5	23.61	PASS
LTE Band 5	1.4MHz	16QAM	20525	1RB#5	22.49	PASS
LTE Band 5	1.4MHz	QPSK	20525	3RB#0	23.57	PASS
LTE Band 5	1.4MHz	16QAM	20525	3RB#0	22.53	PASS



LTE Band 5	1.4MHz	QPSK	20525	3RB#1	23.54	PASS
LTE Band 5	1.4MHz	16QAM	20525	3RB#1	22.52	PASS
LTE Band 5	1.4MHz	QPSK	20525	3RB#3	23.51	PASS
LTE Band 5	1.4MHz	16QAM	20525	3RB#3	22.41	PASS
LTE Band 5	1.4MHz	QPSK	20525	6RB#0	22.57	PASS
LTE Band 5	1.4MHz	16QAM	20525	6RB#0	21.56	PASS
LTE Band 5	1.4MHz	QPSK	20643	1RB#0	23.55	PASS
LTE Band 5	1.4MHz	16QAM	20643	1RB#0	22.68	PASS
LTE Band 5	1.4MHz	QPSK	20643	1RB#2	23.60	PASS
LTE Band 5	1.4MHz	16QAM	20643	1RB#2	22.50	PASS
LTE Band 5	1.4MHz	QPSK	20643	1RB#5	23.45	PASS
LTE Band 5	1.4MHz	16QAM	20643	1RB#5	22.94	PASS
LTE Band 5	1.4MHz	QPSK	20643	3RB#0	23.56	PASS
LTE Band 5	1.4MHz	16QAM	20643	3RB#0	22.42	PASS
LTE Band 5	1.4MHz	QPSK	20643	3RB#1	23.45	PASS
LTE Band 5	1.4MHz	16QAM	20643	3RB#1	22.29	PASS
LTE Band 5	1.4MHz	QPSK	20643	3RB#3	23.22	PASS
LTE Band 5	1.4MHz	16QAM	20643	3RB#3	22.34	PASS
LTE Band 5	1.4MHz	QPSK	20643	6RB#0	22.35	PASS
LTE Band 5	1.4MHz	16QAM	20643	6RB#0	21.48	PASS
LTE Band 5	3MHz	QPSK	20415	1RB#0	23.29	PASS
LTE Band 5	3MHz	16QAM	20415	1RB#0	22.14	PASS
LTE Band 5	3MHz	QPSK	20415	1RB#8	23.09	PASS
LTE Band 5	3MHz	16QAM	20415	1RB#8	22.34	PASS
LTE Band 5	3MHz	QPSK	20415	1RB#14	23.19	PASS
LTE Band 5	3MHz	16QAM	20415	1RB#14	22.61	PASS
LTE Band 5	3MHz	QPSK	20415	8RB#0	22.45	PASS
LTE Band 5	3MHz	16QAM	20415	8RB#0	21.45	PASS
LTE Band 5	3MHz	QPSK	20415	8RB#4	22.37	PASS
LTE Band 5	3MHz	16QAM	20415	8RB#4	21.19	PASS
LTE Band 5	3MHz	QPSK	20415	8RB#7	22.28	PASS
LTE Band 5	3MHz	16QAM	20415	8RB#7	21.38	PASS
LTE Band 5	3MHz	QPSK	20415	15RB#0	22.32	PASS
LTE Band 5	3MHz	16QAM	20415	15RB#0	21.22	PASS
LTE Band 5	3MHz	QPSK	20525	1RB#0	23.76	PASS
LTE Band 5	3MHz	16QAM	20525	1RB#0	22.49	PASS
LTE Band 5	3MHz	QPSK	20525	1RB#8	23.67	PASS
LTE Band 5	3MHz	16QAM	20525	1RB#8	22.59	PASS
LTE Band 5	3MHz	QPSK	20525	1RB#14	23.81	PASS
LTE Band 5	3MHz	16QAM	20525	1RB#14	22.75	PASS
LTE Band 5	3MHz	QPSK	20525	8RB#0	22.52	PASS
LTE Band 5	3MHz	16QAM	20525	8RB#0	21.25	PASS
LTE Band 5	3MHz	QPSK	20525	8RB#4	22.42	PASS



LTE Band 5	3MHz	16QAM	20525	8RB#4	21.43	PASS
LTE Band 5	3MHz	QPSK	20525	8RB#7	22.49	PASS
LTE Band 5	3MHz	16QAM	20525	8RB#7	21.49	PASS
LTE Band 5	3MHz	QPSK	20525	15RB#0	22.48	PASS
LTE Band 5	3MHz	16QAM	20525	15RB#0	21.27	PASS
LTE Band 5	3MHz	QPSK	20635	1RB#0	23.66	PASS
LTE Band 5	3MHz	16QAM	20635	1RB#0	22.34	PASS
LTE Band 5	3MHz	QPSK	20635	1RB#8	23.21	PASS
LTE Band 5	3MHz	16QAM	20635	1RB#8	22.36	PASS
LTE Band 5	3MHz	QPSK	20635	1RB#14	23.39	PASS
LTE Band 5	3MHz	16QAM	20635	1RB#14	22.29	PASS
LTE Band 5	3MHz	QPSK	20635	8RB#0	22.45	PASS
LTE Band 5	3MHz	16QAM	20635	8RB#0	21.68	PASS
LTE Band 5	3MHz	QPSK	20635	8RB#4	22.49	PASS
LTE Band 5	3MHz	16QAM	20635	8RB#4	21.60	PASS
LTE Band 5	3MHz	QPSK	20635	8RB#7	22.42	PASS
LTE Band 5	3MHz	16QAM	20635	8RB#7	21.42	PASS
LTE Band 5	3MHz	QPSK	20635	15RB#0	22.54	PASS
LTE Band 5	3MHz	16QAM	20635	15RB#0	21.42	PASS
LTE Band 5	5MHz	QPSK	20425	1RB#0	23.53	PASS
LTE Band 5	5MHz	16QAM	20425	1RB#0	22.41	PASS
LTE Band 5	5MHz	QPSK	20425	1RB#12	23.76	PASS
LTE Band 5	5MHz	16QAM	20425	1RB#12	22.64	PASS
LTE Band 5	5MHz	QPSK	20425	1RB#24	23.43	PASS
LTE Band 5	5MHz	16QAM	20425	1RB#24	22.69	PASS
LTE Band 5	5MHz	QPSK	20425	12RB#0	22.38	PASS
LTE Band 5	5MHz	16QAM	20425	12RB#0	21.42	PASS
LTE Band 5	5MHz	QPSK	20425	12RB#6	22.47	PASS
LTE Band 5	5MHz	16QAM	20425	12RB#6	21.51	PASS
LTE Band 5	5MHz	QPSK	20425	12RB#13	22.44	PASS
LTE Band 5	5MHz	16QAM	20425	12RB#13	21.49	PASS
LTE Band 5	5MHz	QPSK	20425	25RB#0	22.50	PASS
LTE Band 5	5MHz	16QAM	20425	25RB#0	21.45	PASS
LTE Band 5	5MHz	QPSK	20525	1RB#0	23.61	PASS
LTE Band 5	5MHz	16QAM	20525	1RB#0	22.49	PASS
LTE Band 5	5MHz	QPSK	20525	1RB#12	23.58	PASS
LTE Band 5	5MHz	16QAM	20525	1RB#12	22.54	PASS
LTE Band 5	5MHz	QPSK	20525	1RB#24	23.50	PASS
LTE Band 5	5MHz	16QAM	20525	1RB#24	22.91	PASS
LTE Band 5	5MHz	QPSK	20525	12RB#0	22.42	PASS
LTE Band 5	5MHz	16QAM	20525	12RB#0	21.34	PASS
LTE Band 5	5MHz	QPSK	20525	12RB#6	22.43	PASS
LTE Band 5	5MHz	16QAM	20525	12RB#6	21.32	PASS



LTE Band 5	5MHz	QPSK	20525	12RB#13	22.47	PASS
LTE Band 5	5MHz	16QAM	20525	12RB#13	21.38	PASS
LTE Band 5	5MHz	QPSK	20525	25RB#0	22.39	PASS
LTE Band 5	5MHz	16QAM	20525	25RB#0	21.41	PASS
LTE Band 5	5MHz	QPSK	20625	1RB#0	23.46	PASS
LTE Band 5	5MHz	16QAM	20625	1RB#0	22.15	PASS
LTE Band 5	5MHz	QPSK	20625	1RB#12	23.51	PASS
LTE Band 5	5MHz	16QAM	20625	1RB#12	22.27	PASS
LTE Band 5	5MHz	QPSK	20625	1RB#24	23.43	PASS
LTE Band 5	5MHz	16QAM	20625	1RB#24	22.52	PASS
LTE Band 5	5MHz	QPSK	20625	12RB#0	22.60	PASS
LTE Band 5	5MHz	16QAM	20625	12RB#0	21.52	PASS
LTE Band 5	5MHz	QPSK	20625	12RB#6	22.54	PASS
LTE Band 5	5MHz	16QAM	20625	12RB#6	21.51	PASS
LTE Band 5	5MHz	QPSK	20625	12RB#13	22.55	PASS
LTE Band 5	5MHz	16QAM	20625	12RB#13	21.45	PASS
LTE Band 5	5MHz	QPSK	20625	25RB#0	22.60	PASS
LTE Band 5	5MHz	16QAM	20625	25RB#0	21.50	PASS
LTE Band 5	10MHz	QPSK	20450	1RB#0	23.60	PASS
LTE Band 5	10MHz	16QAM	20450	1RB#0	22.29	PASS
LTE Band 5	10MHz	QPSK	20450	1RB#24	23.37	PASS
LTE Band 5	10MHz	16QAM	20450	1RB#24	22.51	PASS
LTE Band 5	10MHz	QPSK	20450	1RB#49	23.46	PASS
LTE Band 5	10MHz	16QAM	20450	1RB#49	22.40	PASS
LTE Band 5	10MHz	QPSK	20450	25RB#0	22.53	PASS
LTE Band 5	10MHz	16QAM	20450	25RB#0	21.47	PASS
LTE Band 5	10MHz	QPSK	20450	25RB#12	22.41	PASS
LTE Band 5	10MHz	16QAM	20450	25RB#12	21.55	PASS
LTE Band 5	10MHz	QPSK	20450	25RB#25	22.48	PASS
LTE Band 5	10MHz	16QAM	20450	25RB#25	21.42	PASS
LTE Band 5	10MHz	QPSK	20450	50RB#0	22.46	PASS
LTE Band 5	10MHz	16QAM	20450	50RB#0	22.53	PASS
LTE Band 5	10MHz	QPSK	20525	1RB#0	22.66	PASS
LTE Band 5	10MHz	16QAM	20525	1RB#0	22.74	PASS
LTE Band 5	10MHz	QPSK	20525	1RB#24	23.91	PASS
LTE Band 5	10MHz	16QAM	20525	1RB#24	22.95	PASS
LTE Band 5	10MHz	QPSK	20525	1RB#49	23.78	PASS
LTE Band 5	10MHz	16QAM	20525	1RB#49	22.53	PASS
LTE Band 5	10MHz	QPSK	20525	25RB#0	22.53	PASS
LTE Band 5	10MHz	16QAM	20525	25RB#0	21.73	PASS
LTE Band 5	10MHz	QPSK	20525	25RB#12	22.62	PASS
LTE Band 5	10MHz	16QAM	20525	25RB#12	21.70	PASS
LTE Band 5	10MHz	QPSK	20525	25RB#25	22.60	PASS



LTE Band 5	10MHz	16QAM	20525	25RB#25	21.58	PASS
LTE Band 5	10MHz	QPSK	20525	50RB#0	22.61	PASS
LTE Band 5	10MHz	16QAM	20525	50RB#0	22.73	PASS
LTE Band 5	10MHz	QPSK	20600	1RB#0	23.76	PASS
LTE Band 5	10MHz	16QAM	20600	1RB#0	22.89	PASS
LTE Band 5	10MHz	QPSK	20600	1RB#24	23.85	PASS
LTE Band 5	10MHz	16QAM	20600	1RB#24	23.05	PASS
LTE Band 5	10MHz	QPSK	20600	1RB#49	23.66	PASS
LTE Band 5	10MHz	16QAM	20600	1RB#49	22.59	PASS
LTE Band 5	10MHz	QPSK	20600	25RB#0	22.65	PASS
LTE Band 5	10MHz	16QAM	20600	25RB#0	21.64	PASS
LTE Band 5	10MHz	QPSK	20600	25RB#12	22.73	PASS
LTE Band 5	10MHz	16QAM	20600	25RB#12	21.60	PASS
LTE Band 5	10MHz	QPSK	20600	25RB#25	22.74	PASS
LTE Band 5	10MHz	16QAM	20600	25RB#25	21.61	PASS
LTE Band 5	10MHz	QPSK	20600	50RB#0	22.59	PASS
LTE Band 5	10MHz	16QAM	20600	50RB#0	22.82	PASS

5.2. Effective Radiated Power

Ambient condition

Temperature	Relative humidity	Pressure
23°C ~25°C	45%~50%	101.5kPa

Methods of Measurement

The testing follows FCC KDB 971168 v03r01 Section 5.8 and ANSI C63.26 (2015).

- a) Connect the equipment as illustrated. Mount the equipment with the manufacturer specified antenna in a vertical orientation on a manufacturer specified mounting surface located on a non-conducting rotating platform of a RF anechoic chamber (preferred) or a standard radiation site.
- b) Key the transmitter, then rotate the EUT 360° azimuthally and record spectrum analyzer power level (LVL) measurements at angular increments that are sufficiently small to permit resolution of all peaks. If a standard radiation test site is used, raise and lower the test antenna to obtain a maximum reading at each angular increment. (Note: several batteries may be needed to offset the effect of battery voltage droop, which should not exceed 5% of the manufactured specified battery voltage during transmission).
- c) Replace the transmitter under test with a vertically polarized half-wave dipole (or an antenna whose gain is known relative to an ideal half-wave dipole). The center of the antenna should be at the same location as the center of the antenna under test.
- d) Connect the antenna to a signal generator with a known output power and record the path loss (in dB) as LOSS. If a standard radiation test site is used, raise and lower the test antenna to obtain a maximum reading. $LOSS = \text{Generator Output Power (dBm)} - \text{Analyzer reading (dBm)}$
- e) Determine the effective radiated output power at each angular position from the readings in steps b) and d) using the following equation: $ERP \text{ (dBm)} = \text{LVL (dBm)} + \text{LOSS (dB)}$
- f) The maximum ERP is the maximum value determined in the preceding step.
- g) When calculating ERP, in addition to knowing the antenna radiation and matching characteristics, it is necessary to know the loss values of all elements (e.g. transmission line attenuation, mismatches, filters, combiners) interposed between the point where transmitter output power is measured, and the point where power is applied to the antenna. ERP can then be calculated as follows:
 $EIRP \text{ (dBm)} = \text{Output Power (dBm)} - \text{Losses (dB)} + \text{Antenna Gain (dBi)}$
where: dBd refers to gain relative to an ideal dipole.
 $EIRP \text{ (dBm)} = ERP \text{ (dBm)} + 2.15 \text{ (dB.)}$

The RB allocation refers to section 5.1, using the maximum output power configuration.

Test setup

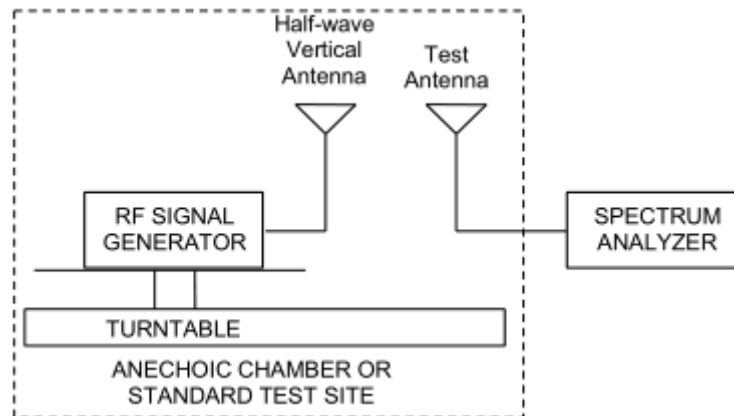
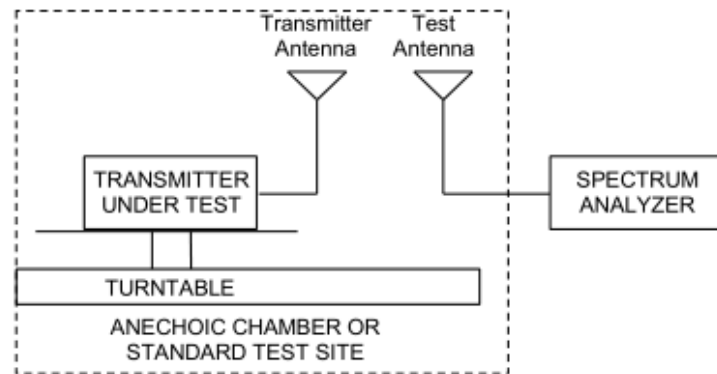

Limits

Rule Part 22.913(a)(5) specifies that "Mobile/portable stations are limited to 7 watts ERP".

Limit	$\leq 7 \text{ W}$ (38.45 dBm)
-------	--------------------------------

Measurement Uncertainty

The assessed measurement uncertainty to ensure 95% confidence level for the normal distribution is with the coverage factor $k = 2$, $U = 1.19 \text{ dB}$

**Test Results:**

The measurement is performed for both of horizontal and vertical antenna Polarization, and only the data of worst mode is recorded in this report.

Band	Channel	PCL	Slot	ERP	Limit (dBm)
GPRS850	128	5	1	33.09	38.45
GPRS850	128	5	2	32.92	38.45
GPRS850	128	5	3	30.45	38.45
GPRS850	128	5	4	29.59	38.45
GPRS850	190	5	1	33.02	38.45
GPRS850	190	5	2	32.51	38.45
GPRS850	190	5	3	30.42	38.45
GPRS850	190	5	4	29.21	38.45
GPRS850	251	5	1	33.00	38.45
GPRS850	251	5	2	32.46	38.45
GPRS850	251	5	3	30.33	38.45
GPRS850	251	5	4	29.10	38.45
EGPRS850	128	8	1	27.84	38.45
EGPRS850	128	8	2	26.96	38.45
EGPRS850	128	8	3	24.56	38.45
EGPRS850	128	8	4	23.30	38.45
EGPRS850	190	8	1	27.60	38.45
EGPRS850	190	8	2	26.65	38.45
EGPRS850	190	8	3	24.39	38.45
EGPRS850	190	8	4	23.14	38.45
EGPRS850	251	8	1	27.61	38.45
EGPRS850	251	8	2	26.45	38.45
EGPRS850	251	8	3	24.43	38.45
EGPRS850	251	8	4	22.94	38.45



Band	Channel	SubTest	Power(dBm)	ERP	Limit (dBm)
WCDMA Band V	4132	-	23.28	24.13	38.45
WCDMA Band V	4281	-	23.46	24.31	38.45
WCDMA Band V	4233	-	23.3	24.15	38.45
WCDMA Band V	4132	HSDPA_Sub0	23.02	23.87	38.45
WCDMA Band V	4132	HSDPA_Sub1	22.51	23.36	38.45
WCDMA Band V	4132	HSDPA_Sub2	22.5	23.35	38.45
WCDMA Band V	4132	HSDPA_Sub3	22.49	23.34	38.45
WCDMA Band V	4182	HSDPA_Sub0	23.02	23.87	38.45
WCDMA Band V	4182	HSDPA_Sub1	22.52	23.37	38.45
WCDMA Band V	4182	HSDPA_Sub2	22.52	23.37	38.45
WCDMA Band V	4182	HSDPA_Sub3	22.62	23.47	38.45
WCDMA Band V	4233	HSDPA_Sub0	22.98	23.83	38.45
WCDMA Band V	4233	HSDPA_Sub1	22.58	23.43	38.45
WCDMA Band V	4233	HSDPA_Sub2	22.48	23.33	38.45
WCDMA Band V	4233	HSDPA_Sub3	22.58	23.43	38.45
WCDMA Band V	4132	HSUPA_Sub1	22.68	23.53	38.45
WCDMA Band V	4132	HSUPA_Sub2	20.92	21.77	38.45
WCDMA Band V	4132	HSUPA_Sub3	22.12	22.97	38.45
WCDMA Band V	4132	HSUPA_Sub4	21.54	22.39	38.45
WCDMA Band V	4132	HSUPA_Sub5	22.88	23.73	38.45
WCDMA Band V	4182	HSUPA_Sub1	22.99	23.84	38.45
WCDMA Band V	4182	HSUPA_Sub2	21.1	21.95	38.45
WCDMA Band V	4182	HSUPA_Sub3	22.14	22.99	38.45
WCDMA Band V	4182	HSUPA_Sub4	21.75	22.60	38.45
WCDMA Band V	4182	HSUPA_Sub5	23	23.85	38.45
WCDMA Band V	4233	HSUPA_Sub1	22.59	23.44	38.45
WCDMA Band V	4233	HSUPA_Sub2	21.12	21.97	38.45
WCDMA Band V	4233	HSUPA_Sub3	22.25	23.10	38.45
WCDMA Band V	4233	HSUPA_Sub4	21.64	22.49	38.45
WCDMA Band V	4233	HSUPA_Sub5	23.01	23.86	38.45



Band	Bandwidth	Modulation	Channel	RB Configuration	ERP	Limit (dBm)
LTE Band 5	1.4MHz	QPSK	20407	1RB#0	24.40	38.45
LTE Band 5	1.4MHz	16QAM	20407	1RB#0	23.66	38.45
LTE Band 5	1.4MHz	QPSK	20407	1RB#2	24.71	38.45
LTE Band 5	1.4MHz	16QAM	20407	1RB#2	23.78	38.45
LTE Band 5	1.4MHz	QPSK	20407	1RB#5	24.64	38.45
LTE Band 5	1.4MHz	16QAM	20407	1RB#5	23.75	38.45
LTE Band 5	1.4MHz	QPSK	20407	3RB#0	24.29	38.45
LTE Band 5	1.4MHz	16QAM	20407	3RB#0	23.18	38.45
LTE Band 5	1.4MHz	QPSK	20407	3RB#1	24.25	38.45
LTE Band 5	1.4MHz	16QAM	20407	3RB#1	23.16	38.45
LTE Band 5	1.4MHz	QPSK	20407	3RB#3	24.28	38.45
LTE Band 5	1.4MHz	16QAM	20407	3RB#3	23.17	38.45
LTE Band 5	1.4MHz	QPSK	20407	6RB#0	23.19	38.45
LTE Band 5	1.4MHz	16QAM	20407	6RB#0	22.33	38.45
LTE Band 5	1.4MHz	QPSK	20525	1RB#0	24.42	38.45
LTE Band 5	1.4MHz	16QAM	20525	1RB#0	23.32	38.45
LTE Band 5	1.4MHz	QPSK	20525	1RB#2	24.66	38.45
LTE Band 5	1.4MHz	16QAM	20525	1RB#2	24.23	38.45
LTE Band 5	1.4MHz	QPSK	20525	1RB#5	24.46	38.45
LTE Band 5	1.4MHz	16QAM	20525	1RB#5	23.34	38.45
LTE Band 5	1.4MHz	QPSK	20525	3RB#0	24.42	38.45
LTE Band 5	1.4MHz	16QAM	20525	3RB#0	23.38	38.45
LTE Band 5	1.4MHz	QPSK	20525	3RB#1	24.39	38.45
LTE Band 5	1.4MHz	16QAM	20525	3RB#1	23.37	38.45
LTE Band 5	1.4MHz	QPSK	20525	3RB#3	24.36	38.45
LTE Band 5	1.4MHz	16QAM	20525	3RB#3	23.26	38.45
LTE Band 5	1.4MHz	QPSK	20525	6RB#0	23.42	38.45
LTE Band 5	1.4MHz	16QAM	20525	6RB#0	22.41	38.45
LTE Band 5	1.4MHz	QPSK	20643	1RB#0	24.40	38.45
LTE Band 5	1.4MHz	16QAM	20643	1RB#0	23.53	38.45
LTE Band 5	1.4MHz	QPSK	20643	1RB#2	24.45	38.45
LTE Band 5	1.4MHz	16QAM	20643	1RB#2	23.35	38.45
LTE Band 5	1.4MHz	QPSK	20643	1RB#5	24.30	38.45
LTE Band 5	1.4MHz	16QAM	20643	1RB#5	23.79	38.45
LTE Band 5	1.4MHz	QPSK	20643	3RB#0	24.41	38.45
LTE Band 5	1.4MHz	16QAM	20643	3RB#0	23.27	38.45
LTE Band 5	1.4MHz	QPSK	20643	3RB#1	24.3	38.45
LTE Band 5	1.4MHz	16QAM	20643	3RB#1	23.14	38.45



LTE Band 5	1.4MHz	QPSK	20643	3RB#3	24.07	38.45
LTE Band 5	1.4MHz	16QAM	20643	3RB#3	23.19	38.45
LTE Band 5	1.4MHz	QPSK	20643	6RB#0	23.2	38.45
LTE Band 5	1.4MHz	16QAM	20643	6RB#0	22.33	38.45
LTE Band 5	3MHz	QPSK	20415	1RB#0	24.14	38.45
LTE Band 5	3MHz	16QAM	20415	1RB#0	22.99	38.45
LTE Band 5	3MHz	QPSK	20415	1RB#8	23.94	38.45
LTE Band 5	3MHz	16QAM	20415	1RB#8	23.19	38.45
LTE Band 5	3MHz	QPSK	20415	1RB#14	24.04	38.45
LTE Band 5	3MHz	16QAM	20415	1RB#14	23.46	38.45
LTE Band 5	3MHz	QPSK	20415	8RB#0	23.3	38.45
LTE Band 5	3MHz	16QAM	20415	8RB#0	22.3	38.45
LTE Band 5	3MHz	QPSK	20415	8RB#4	23.22	38.45
LTE Band 5	3MHz	16QAM	20415	8RB#4	22.04	38.45
LTE Band 5	3MHz	QPSK	20415	8RB#7	23.13	38.45
LTE Band 5	3MHz	16QAM	20415	8RB#7	22.23	38.45
LTE Band 5	3MHz	QPSK	20415	15RB#0	23.17	38.45
LTE Band 5	3MHz	16QAM	20415	15RB#0	22.07	38.45
LTE Band 5	3MHz	QPSK	20525	1RB#0	24.61	38.45
LTE Band 5	3MHz	16QAM	20525	1RB#0	23.34	38.45
LTE Band 5	3MHz	QPSK	20525	1RB#8	24.52	38.45
LTE Band 5	3MHz	16QAM	20525	1RB#8	23.44	38.45
LTE Band 5	3MHz	QPSK	20525	1RB#14	24.66	38.45
LTE Band 5	3MHz	16QAM	20525	1RB#14	23.6	38.45
LTE Band 5	3MHz	QPSK	20525	8RB#0	23.37	38.45
LTE Band 5	3MHz	16QAM	20525	8RB#0	22.1	38.45
LTE Band 5	3MHz	QPSK	20525	8RB#4	23.27	38.45
LTE Band 5	3MHz	16QAM	20525	8RB#4	22.28	38.45
LTE Band 5	3MHz	QPSK	20525	8RB#7	23.34	38.45
LTE Band 5	3MHz	16QAM	20525	8RB#7	22.34	38.45
LTE Band 5	3MHz	QPSK	20525	15RB#0	23.33	38.45
LTE Band 5	3MHz	16QAM	20525	15RB#0	22.12	38.45
LTE Band 5	3MHz	QPSK	20635	1RB#0	24.51	38.45
LTE Band 5	3MHz	16QAM	20635	1RB#0	23.19	38.45
LTE Band 5	3MHz	QPSK	20635	1RB#8	24.06	38.45
LTE Band 5	3MHz	16QAM	20635	1RB#8	23.21	38.45
LTE Band 5	3MHz	QPSK	20635	1RB#14	24.24	38.45
LTE Band 5	3MHz	16QAM	20635	1RB#14	23.14	38.45
LTE Band 5	3MHz	QPSK	20635	8RB#0	23.3	38.45
LTE Band 5	3MHz	16QAM	20635	8RB#0	22.53	38.45
LTE Band 5	3MHz	QPSK	20635	8RB#4	23.34	38.45
LTE Band 5	3MHz	16QAM	20635	8RB#4	22.45	38.45



LTE Band 5	3MHz	QPSK	20635	8RB#7	23.27	38.45
LTE Band 5	3MHz	16QAM	20635	8RB#7	22.27	38.45
LTE Band 5	3MHz	QPSK	20635	15RB#0	23.39	38.45
LTE Band 5	3MHz	16QAM	20635	15RB#0	22.27	38.45
LTE Band 5	5MHz	QPSK	20425	1RB#0	24.38	38.45
LTE Band 5	5MHz	16QAM	20425	1RB#0	23.26	38.45
LTE Band 5	5MHz	QPSK	20425	1RB#12	24.61	38.45
LTE Band 5	5MHz	16QAM	20425	1RB#12	23.49	38.45
LTE Band 5	5MHz	QPSK	20425	1RB#24	24.28	38.45
LTE Band 5	5MHz	16QAM	20425	1RB#24	23.54	38.45
LTE Band 5	5MHz	QPSK	20425	12RB#0	23.23	38.45
LTE Band 5	5MHz	16QAM	20425	12RB#0	22.27	38.45
LTE Band 5	5MHz	QPSK	20425	12RB#6	23.32	38.45
LTE Band 5	5MHz	16QAM	20425	12RB#6	22.36	38.45
LTE Band 5	5MHz	QPSK	20425	12RB#13	23.29	38.45
LTE Band 5	5MHz	16QAM	20425	12RB#13	22.34	38.45
LTE Band 5	5MHz	QPSK	20425	25RB#0	23.35	38.45
LTE Band 5	5MHz	16QAM	20425	25RB#0	22.3	38.45
LTE Band 5	5MHz	QPSK	20525	1RB#0	24.46	38.45
LTE Band 5	5MHz	16QAM	20525	1RB#0	23.34	38.45
LTE Band 5	5MHz	QPSK	20525	1RB#12	24.43	38.45
LTE Band 5	5MHz	16QAM	20525	1RB#12	23.39	38.45
LTE Band 5	5MHz	QPSK	20525	1RB#24	24.35	38.45
LTE Band 5	5MHz	16QAM	20525	1RB#24	23.76	38.45
LTE Band 5	5MHz	QPSK	20525	12RB#0	23.27	38.45
LTE Band 5	5MHz	16QAM	20525	12RB#0	22.19	38.45
LTE Band 5	5MHz	QPSK	20525	12RB#6	23.28	38.45
LTE Band 5	5MHz	16QAM	20525	12RB#6	22.17	38.45
LTE Band 5	5MHz	QPSK	20525	12RB#13	23.32	38.45
LTE Band 5	5MHz	16QAM	20525	12RB#13	22.23	38.45
LTE Band 5	5MHz	QPSK	20525	25RB#0	23.24	38.45
LTE Band 5	5MHz	16QAM	20525	25RB#0	22.26	38.45
LTE Band 5	5MHz	QPSK	20625	1RB#0	24.31	38.45
LTE Band 5	5MHz	16QAM	20625	1RB#0	23	38.45
LTE Band 5	5MHz	QPSK	20625	1RB#12	24.36	38.45
LTE Band 5	5MHz	16QAM	20625	1RB#12	23.12	38.45
LTE Band 5	5MHz	QPSK	20625	1RB#24	24.28	38.45
LTE Band 5	5MHz	16QAM	20625	1RB#24	23.37	38.45
LTE Band 5	5MHz	QPSK	20625	12RB#0	23.45	38.45
LTE Band 5	5MHz	16QAM	20625	12RB#0	22.37	38.45
LTE Band 5	5MHz	QPSK	20625	12RB#6	23.39	38.45
LTE Band 5	5MHz	16QAM	20625	12RB#6	22.36	38.45



LTE Band 5	5MHz	QPSK	20625	12RB#13	23.4	38.45
LTE Band 5	5MHz	16QAM	20625	12RB#13	22.3	38.45
LTE Band 5	5MHz	QPSK	20625	25RB#0	23.45	38.45
LTE Band 5	5MHz	16QAM	20625	25RB#0	22.35	38.45
LTE Band 5	10MHz	QPSK	20450	1RB#0	24.45	38.45
LTE Band 5	10MHz	16QAM	20450	1RB#0	23.14	38.45
LTE Band 5	10MHz	QPSK	20450	1RB#24	24.22	38.45
LTE Band 5	10MHz	16QAM	20450	1RB#24	23.36	38.45
LTE Band 5	10MHz	QPSK	20450	1RB#49	24.31	38.45
LTE Band 5	10MHz	16QAM	20450	1RB#49	23.25	38.45
LTE Band 5	10MHz	QPSK	20450	25RB#0	23.38	38.45
LTE Band 5	10MHz	16QAM	20450	25RB#0	22.32	38.45
LTE Band 5	10MHz	QPSK	20450	25RB#12	23.26	38.45
LTE Band 5	10MHz	16QAM	20450	25RB#12	22.4	38.45
LTE Band 5	10MHz	QPSK	20450	25RB#25	23.33	38.45
LTE Band 5	10MHz	16QAM	20450	25RB#25	22.27	38.45
LTE Band 5	10MHz	QPSK	20450	50RB#0	23.31	38.45
LTE Band 5	10MHz	16QAM	20450	50RB#0	23.38	38.45
LTE Band 5	10MHz	QPSK	20525	1RB#0	23.51	38.45
LTE Band 5	10MHz	16QAM	20525	1RB#0	23.59	38.45
LTE Band 5	10MHz	QPSK	20525	1RB#24	24.76	38.45
LTE Band 5	10MHz	16QAM	20525	1RB#24	23.8	38.45
LTE Band 5	10MHz	QPSK	20525	1RB#49	24.63	38.45
LTE Band 5	10MHz	16QAM	20525	1RB#49	23.38	38.45
LTE Band 5	10MHz	QPSK	20525	25RB#0	23.38	38.45
LTE Band 5	10MHz	16QAM	20525	25RB#0	22.58	38.45
LTE Band 5	10MHz	QPSK	20525	25RB#12	23.47	38.45
LTE Band 5	10MHz	16QAM	20525	25RB#12	22.55	38.45
LTE Band 5	10MHz	QPSK	20525	25RB#25	23.45	38.45
LTE Band 5	10MHz	16QAM	20525	25RB#25	22.43	38.45
LTE Band 5	10MHz	QPSK	20525	50RB#0	23.46	38.45
LTE Band 5	10MHz	16QAM	20525	50RB#0	23.58	38.45
LTE Band 5	10MHz	QPSK	20600	1RB#0	24.61	38.45
LTE Band 5	10MHz	16QAM	20600	1RB#0	23.74	38.45
LTE Band 5	10MHz	QPSK	20600	1RB#24	24.7	38.45
LTE Band 5	10MHz	16QAM	20600	1RB#24	23.9	38.45
LTE Band 5	10MHz	QPSK	20600	1RB#49	24.51	38.45
LTE Band 5	10MHz	16QAM	20600	1RB#49	23.44	38.45
LTE Band 5	10MHz	QPSK	20600	25RB#0	23.5	38.45
LTE Band 5	10MHz	16QAM	20600	25RB#0	22.49	38.45
LTE Band 5	10MHz	QPSK	20600	25RB#12	23.58	38.45
LTE Band 5	10MHz	16QAM	20600	25RB#12	22.45	38.45



LTE Band 5	10MHz	QPSK	20600	25RB#25	23.59	38.45
LTE Band 5	10MHz	16QAM	20600	25RB#25	22.46	38.45
LTE Band 5	10MHz	QPSK	20600	50RB#0	23.44	38.45
LTE Band 5	10MHz	16QAM	20600	50RB#0	23.67	38.45

5.3. Occupied Bandwidth

Ambient condition

Temperature	Relative humidity	Pressure
23°C ~25°C	45%~50%	101.5kPa

Method of Measurement

The EUT was connected to Spectrum Analyzer and Base Station Simulator via power Splitter. The occupied bandwidth is measured using spectrum analyzer.

RBW is set to 5.1kHz, VBW is set to 51kHz for GSM 850,

RBW is set to 100kHz, VBW is set to 300kHz for WCDMA Band V,

RBW is set to 51 kHz, VBW is set to 51 kHz for LTE Band 5 (1.4MHz/3MHz/5MHz/10MHz),

99% power and -26dBc occupied bandwidths are recorded. Spectrum analyzer plots are included on the following pages.

Test Setup

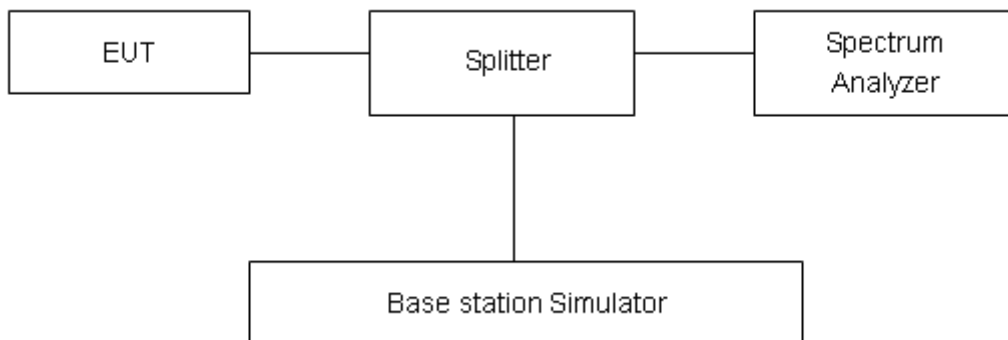

Limits

No specific occupied bandwidth requirements in part 2.1049.

Measurement Uncertainty

The assessed measurement uncertainty to ensure 95% confidence level for the normal distribution is with the coverage factor $k = 2$, $U = 624\text{Hz}$.

**Test Result**

Band	Channel	Occupied Bandwidth (kHz)	26dB Bandwidth (kHz)	Limit(kHz)	Verdict
GPRS850	128	241.40	313.8	---	PASS
GPRS850	190	244.09	312.7	---	PASS
GPRS850	251	244.04	314.7	---	PASS
EGPRS850	128	242.44	315.1	---	PASS
EGPRS850	190	243.03	310.3	---	PASS
EGPRS850	251	243.66	298.5	---	PASS

Band	Channel	Occupied Bandwidth (kHz)	26dB Bandwidth (kHz)	Limit(kHz)	Verdict
WCDMA Band V	4132	4122.6	4686	---	PASS
WCDMA Band V	4182	4122.4	4695	---	PASS
WCDMA Band V	4233	4129.9	4699	---	PASS



Band	Bandwidth	Modulation	Channel	RB Configuration	Occupied Bandwidth (MHz)	26dB Bandwidth (MHz)	Verdict
LTE Band 5	1.4MHz	QPSK	20407	6RB#0	1.1106	1.284	PASS
LTE Band 5	1.4MHz	16QAM	20407	6RB#0	1.1092	1.292	PASS
LTE Band 5	1.4MHz	QPSK	20525	6RB#0	1.1097	1.274	PASS
LTE Band 5	1.4MHz	16QAM	20525	6RB#0	1.1090	1.261	PASS
LTE Band 5	1.4MHz	QPSK	20643	6RB#0	1.1087	1.270	PASS
LTE Band 5	1.4MHz	16QAM	20643	6RB#0	1.1101	1.300	PASS
LTE Band 5	3MHz	QPSK	20415	15RB#0	2.6901	2.928	PASS
LTE Band 5	3MHz	16QAM	20415	15RB#0	2.6958	2.935	PASS
LTE Band 5	3MHz	QPSK	20525	15RB#0	2.6995	2.901	PASS
LTE Band 5	3MHz	16QAM	20525	15RB#0	2.6987	2.907	PASS
LTE Band 5	3MHz	QPSK	20635	15RB#0	2.6988	2.917	PASS
LTE Band 5	3MHz	16QAM	20635	15RB#0	2.6909	2.925	PASS
LTE Band 5	5MHz	QPSK	20425	25RB#0	4.4746	4.848	PASS
LTE Band 5	5MHz	16QAM	20425	25RB#0	4.4751	4.813	PASS
LTE Band 5	5MHz	QPSK	20525	25RB#0	4.4733	4.822	PASS
LTE Band 5	5MHz	16QAM	20525	25RB#0	4.4715	4.846	PASS
LTE Band 5	5MHz	QPSK	20625	25RB#0	4.4786	4.829	PASS
LTE Band 5	5MHz	16QAM	20625	25RB#0	4.4771	4.797	PASS
LTE Band 5	10MHz	QPSK	20450	50RB#0	8.9146	9.357	PASS
LTE Band 5	10MHz	16QAM	20450	50RB#0	8.9032	9.376	PASS
LTE Band 5	10MHz	QPSK	20525	50RB#0	8.9143	9.371	PASS
LTE Band 5	10MHz	16QAM	20525	50RB#0	8.9077	9.386	PASS
LTE Band 5	10MHz	QPSK	20600	50RB#0	8.9123	9.338	PASS
LTE Band 5	10MHz	16QAM	20600	50RB#0	8.9029	9.318	PASS



GPRS850-128

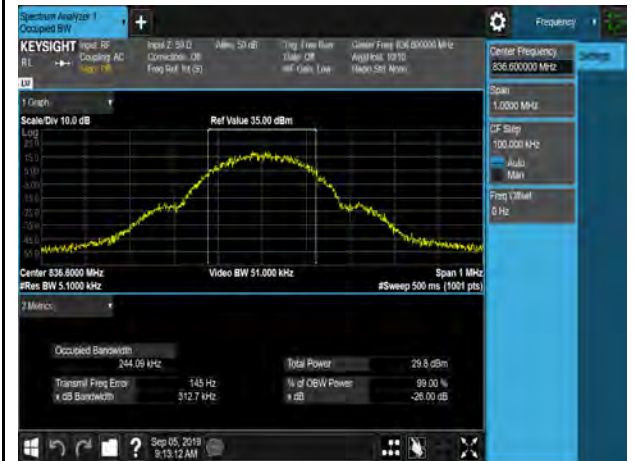

GPRS850-190



GPRS850-251



EGPRS850-128



EGPRS850-190



EGPRS850-251



WCDMA Band V_4132



WCDMA Band V_4182



WCDMA Band V_4233

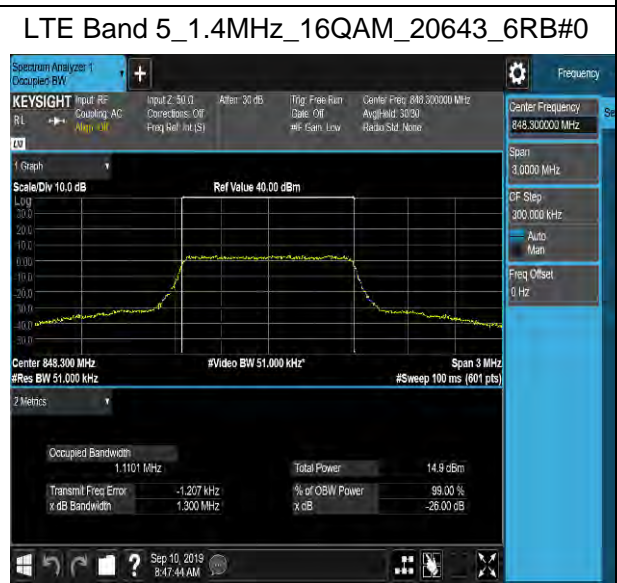
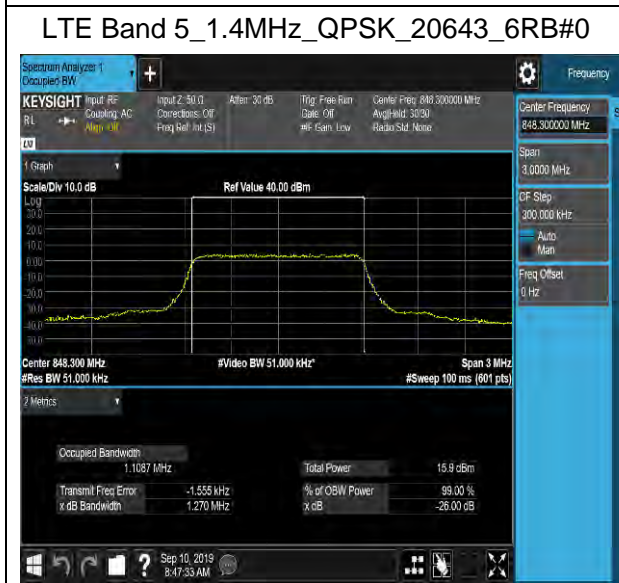
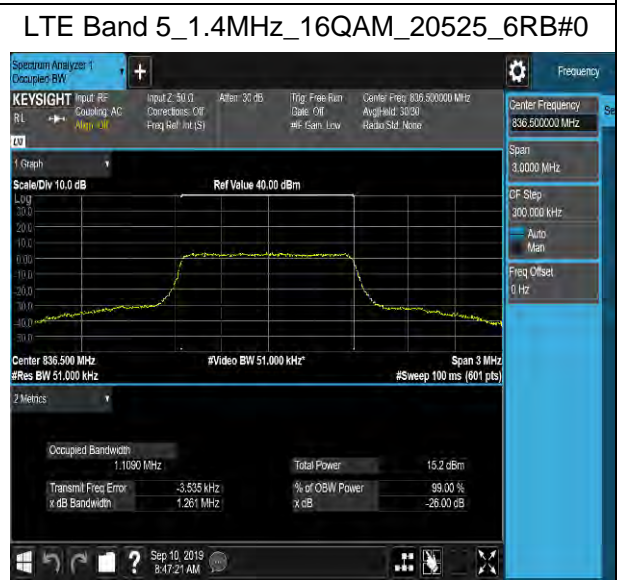
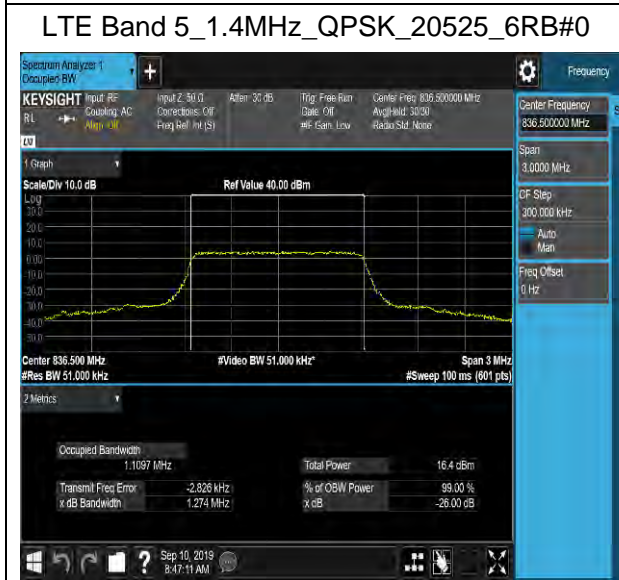
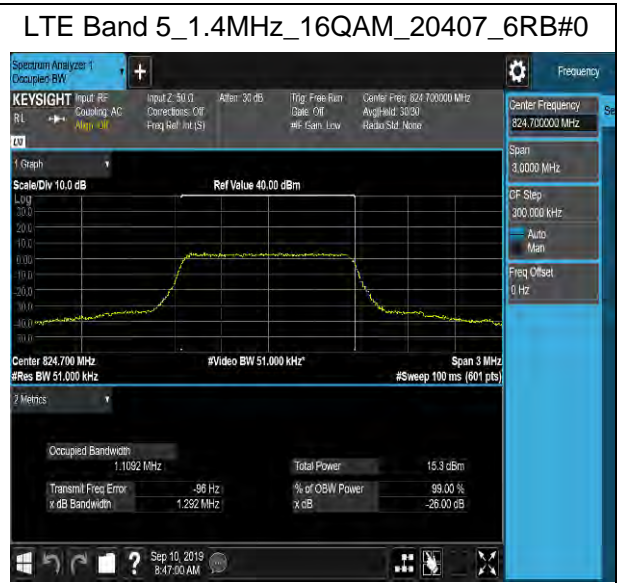
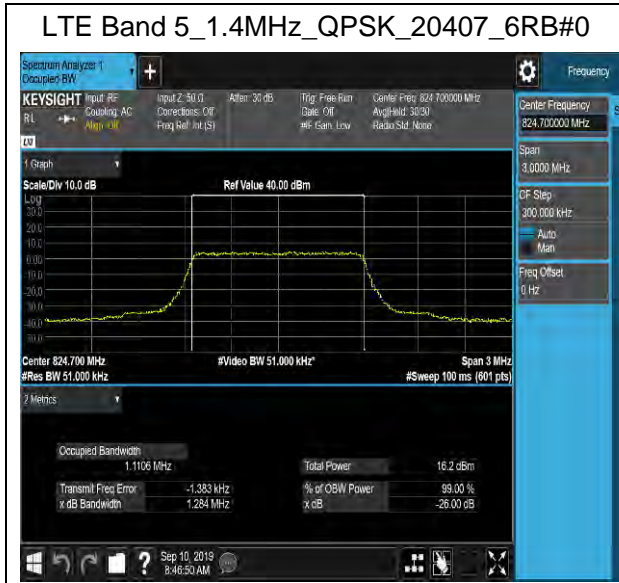

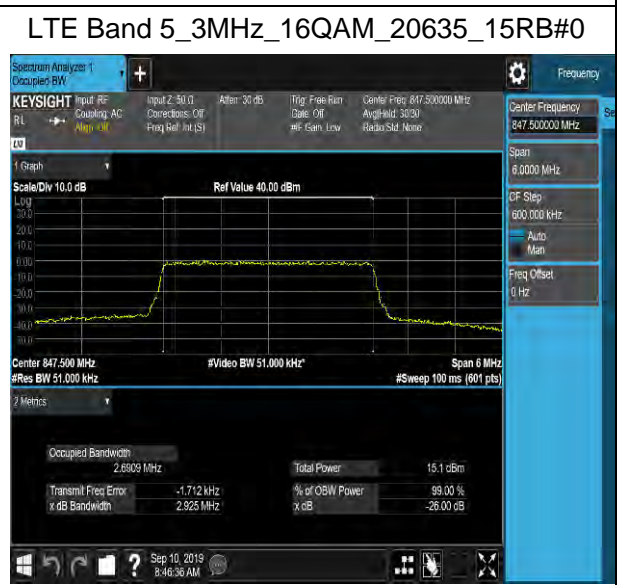
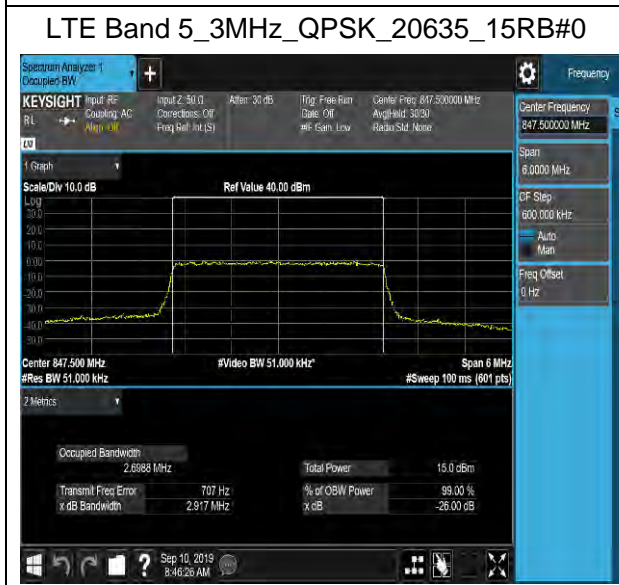
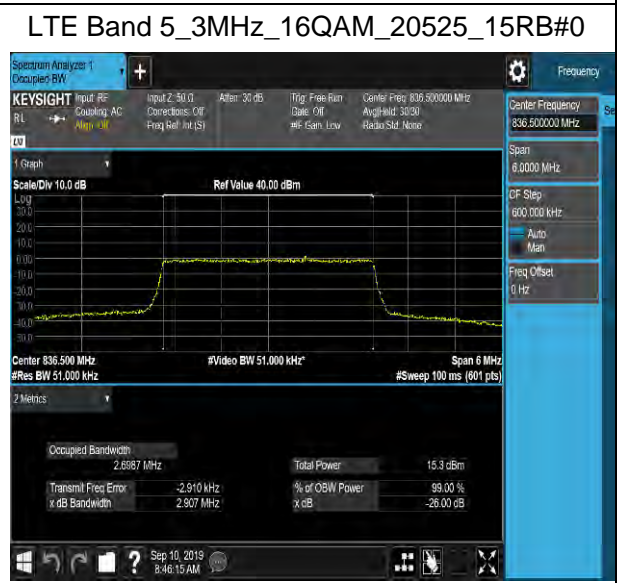
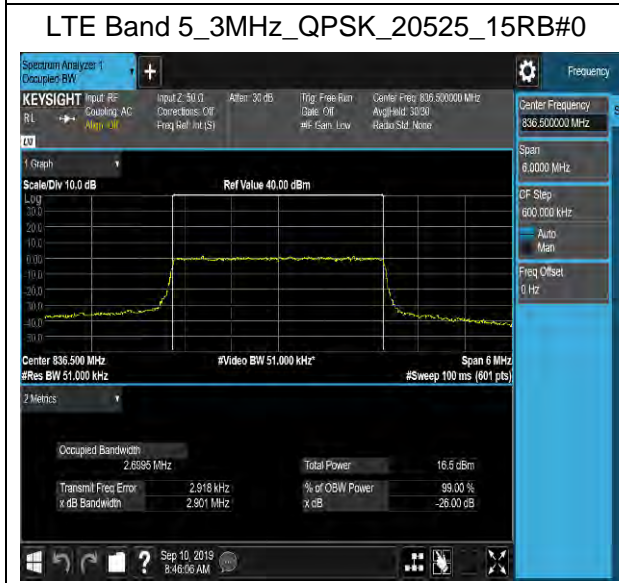
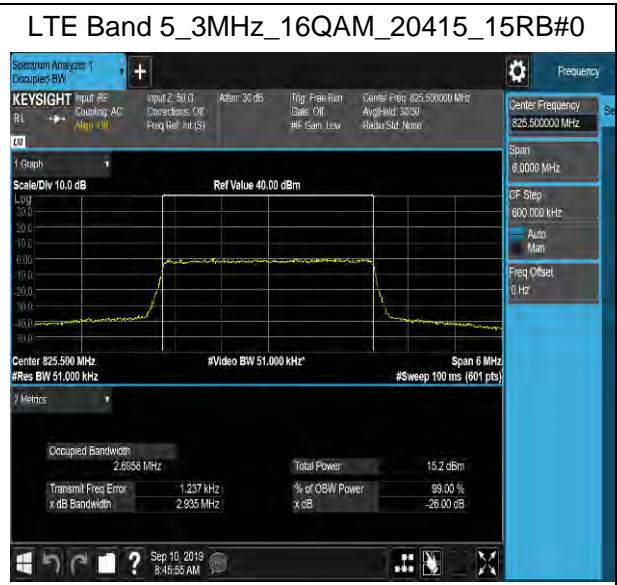
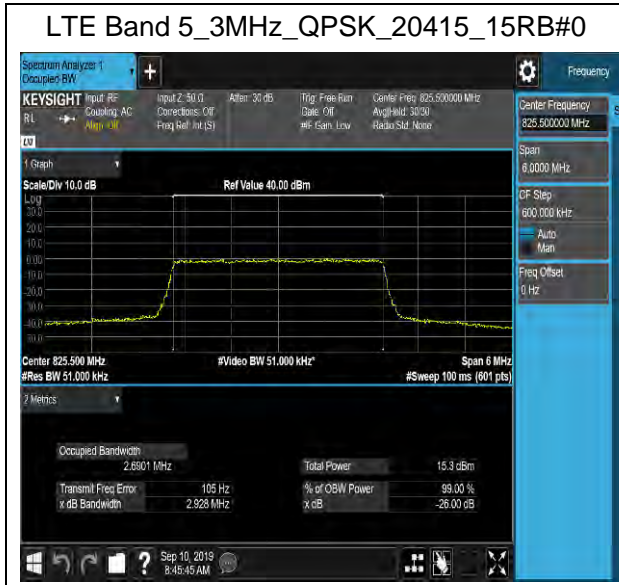

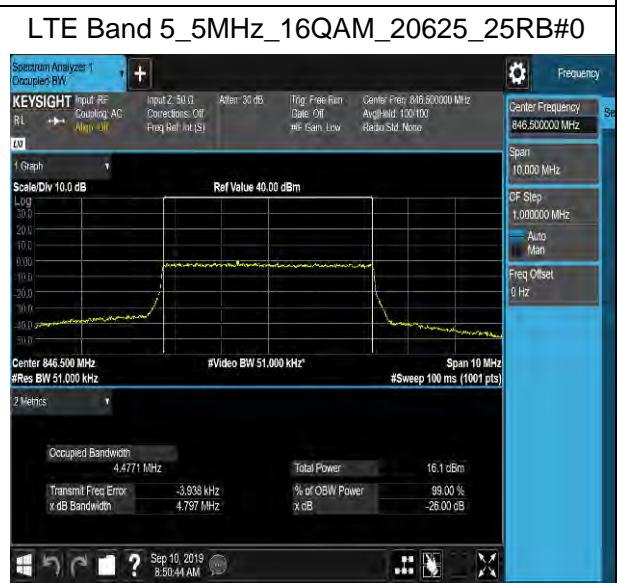
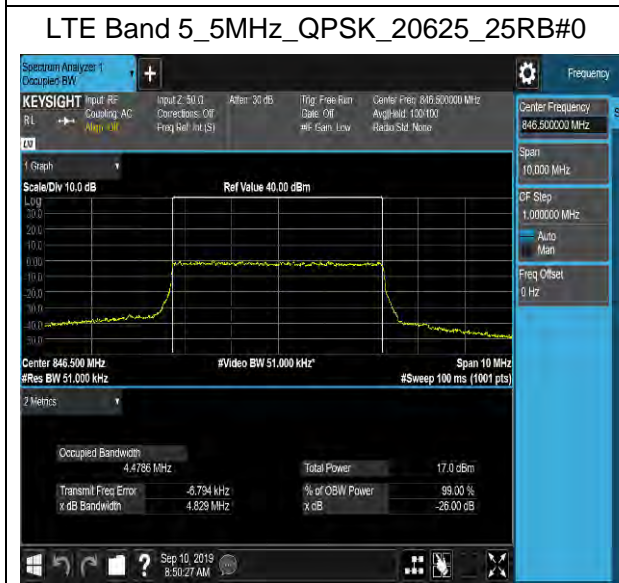
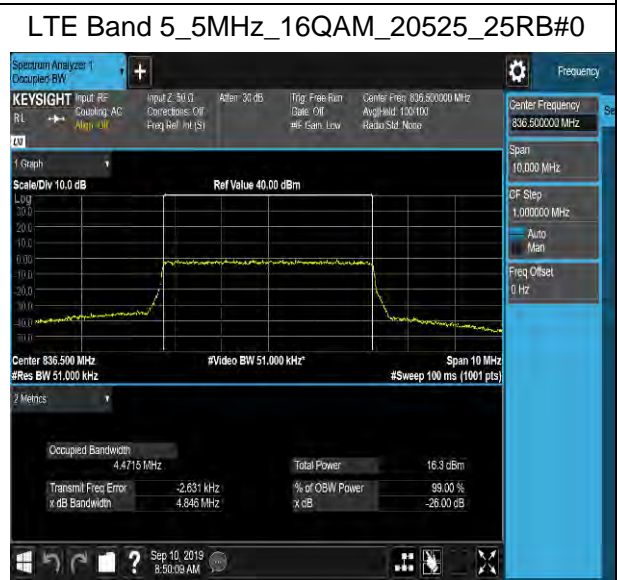
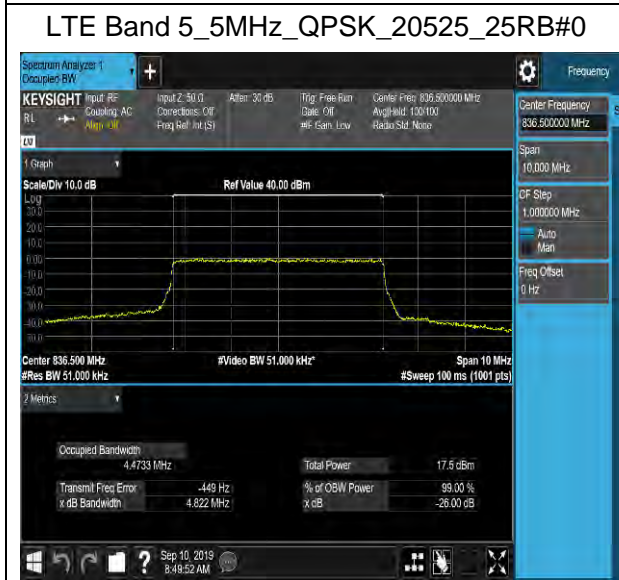
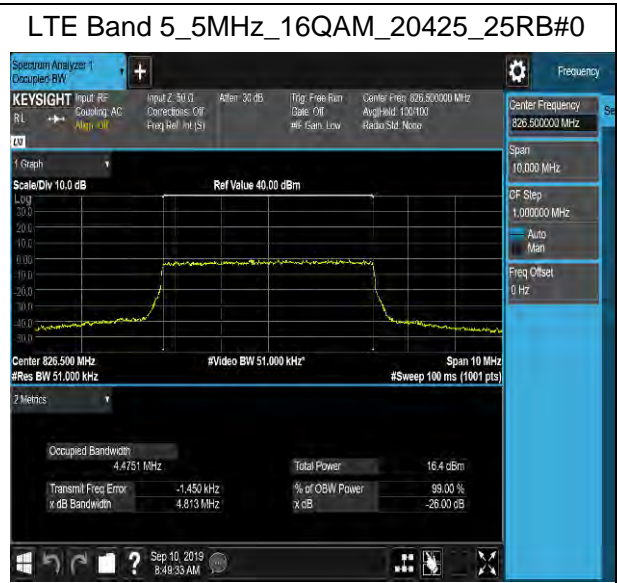
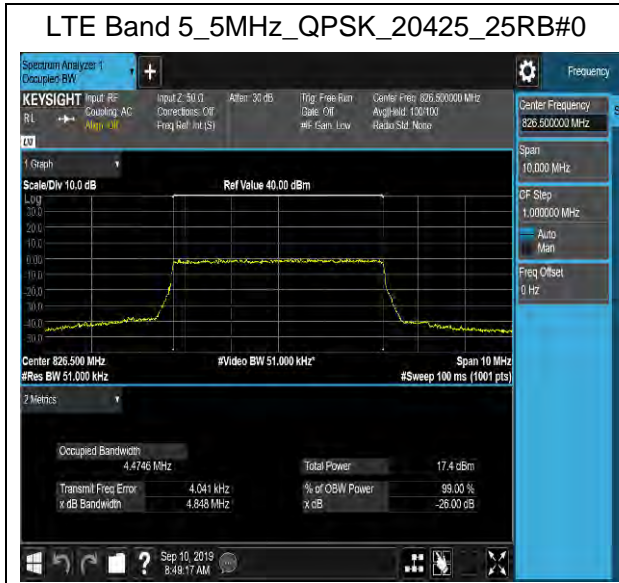

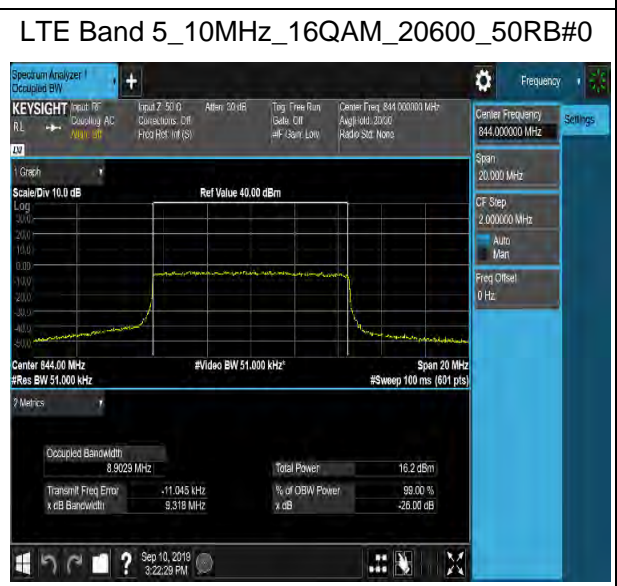
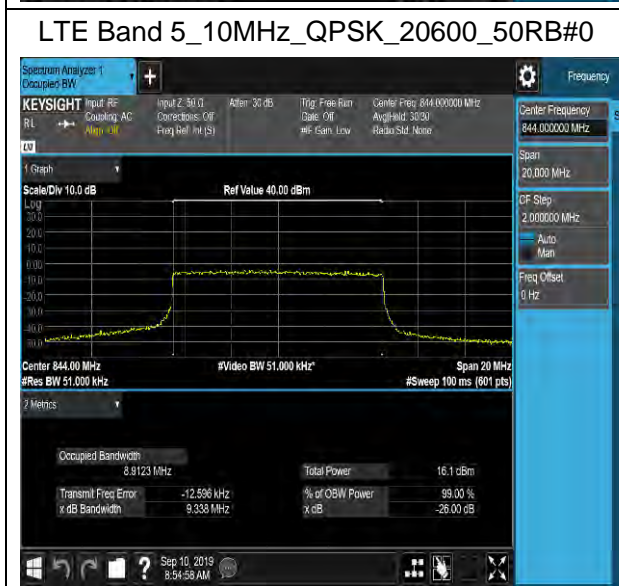
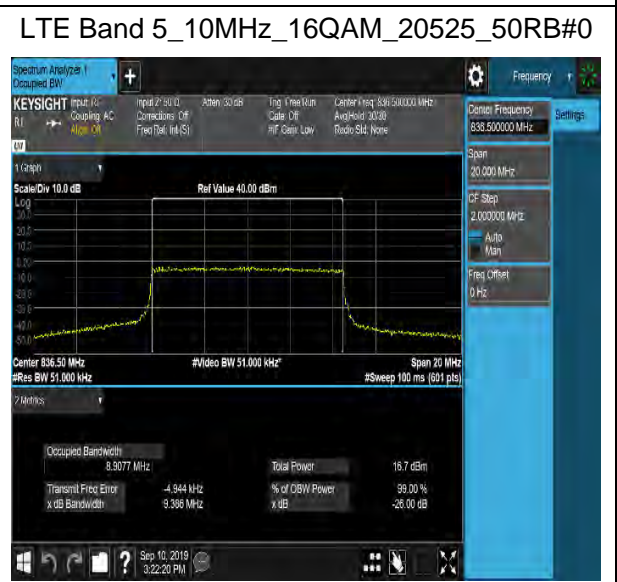
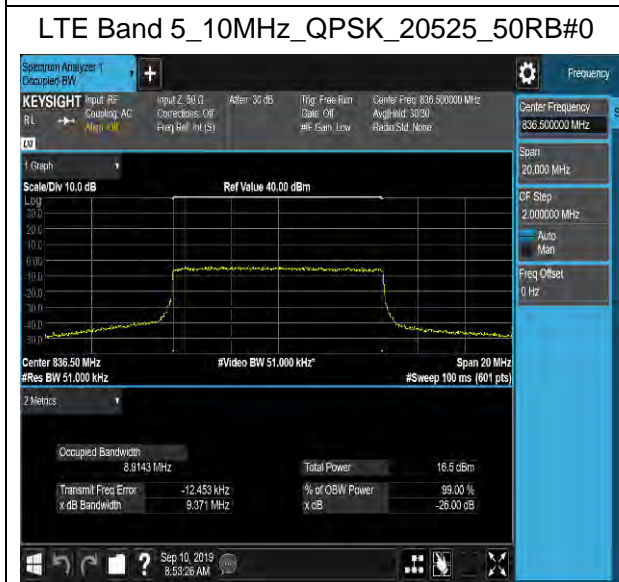
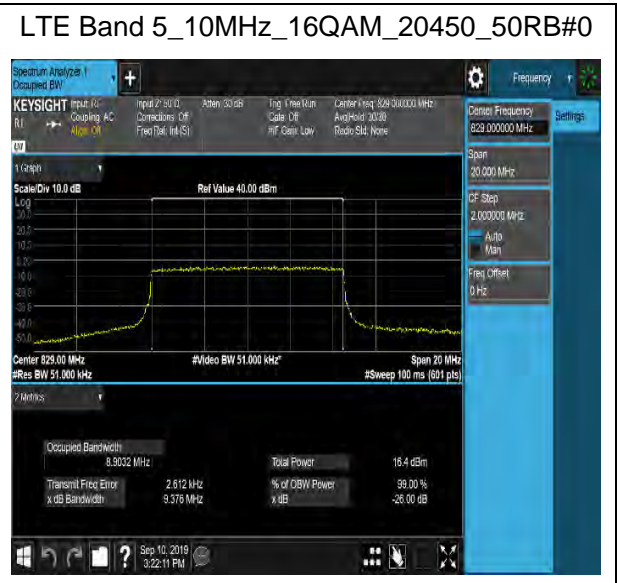
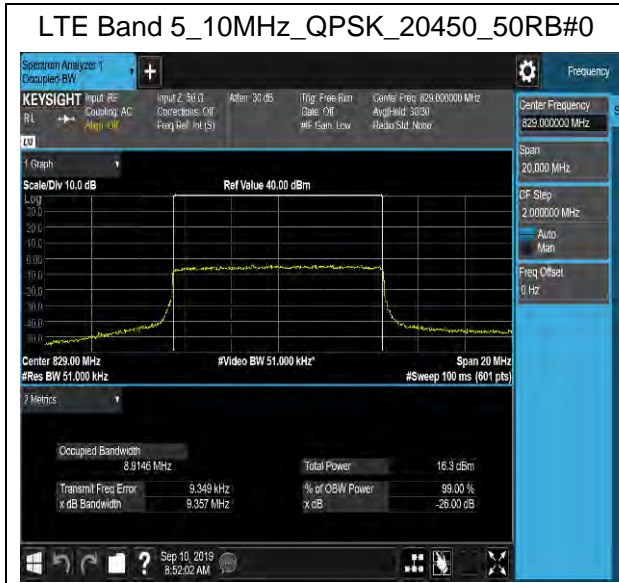

5.4. Band Edge Compliance

Ambient condition

Temperature	Relative humidity	Pressure
23°C ~25°C	45%~50%	101.5kPa

Method of Measurement

The EUT was connected to Spectrum Analyzer and Base Station Simulator via power Splitter. The band edge of the lowest and highest channels were measured. The average detector is used. RBW is set to 5.1kHz,VBW is set to 51kHz for GSM 850, RBW is set to 51kHz,VBW is set to 200kHz for WCDMA Band V, RBW is set to 51 kHz, VBW is set to 150 kHz for LTE Band 5 (1.4MHz/3MHz/5MHz), RBW is set to 100 kHz, VBW is set to 300 kHz for LTE Band 5 (10MHz), Spectrum analyzer plots are included on the following pages.

Test Setup

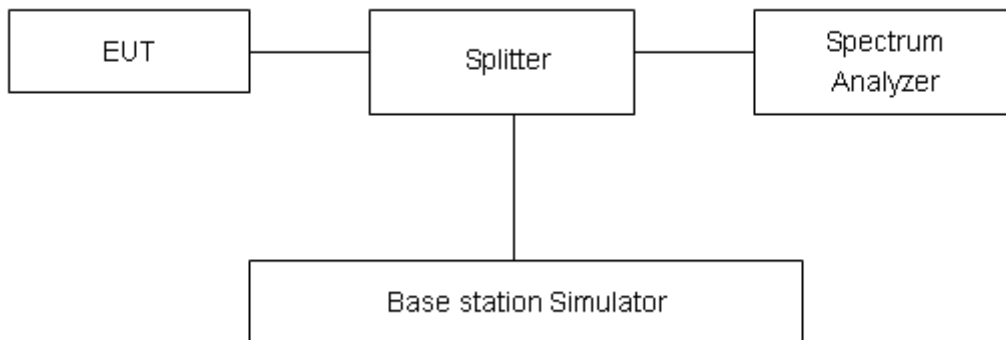

Limits

Rule Part 22.917(a) specifies that “The power of any emission outside of the authorized operating frequency ranges must be attenuated below the transmitting power (P) by a factor of at least 43 + 10 log(P) dB.”

Limit	-13 dBm
-------	---------

Measurement Uncertainty

The assessed measurement uncertainty to ensure 95% confidence level for the normal distribution is with the coverage factor $k = 1.96$, $U=0.684$ dB.

Test Result:



GPRS850-128



GPRS850-251



EGPRS850-128



EGPRS850-251



WCDMA Band V_4132



WCDMA Band V_4233



LTE Band 5_1.4MHz_QPSK_20407_1RB#0



LTE Band 5_1.4MHz_16QAM_20407_1RB#0



LTE Band 5_1.4MHz_QPSK_20407_1RB#2



LTE Band 5_1.4MHz_16QAM_20407_1RB#2

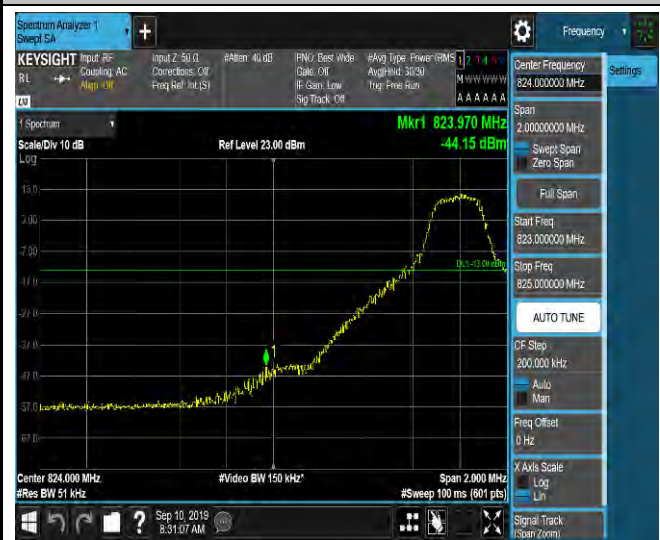

LTE Band 5_1.4MHz_QPSK_20407_1RB#5



LTE Band 5_1.4MHz_16QAM_20407_1RB#5





LTE Band 5_1.4MHz_QPSK_20407_3RB#0

LTE Band 5_1.4MHz_16QAM_20407_3RB#0



LTE Band 5_1.4MHz_QPSK_20407_3RB#1

LTE Band 5_1.4MHz_16QAM_20407_3RB#1



LTE Band 5_1.4MHz_QPSK_20407_3RB#3

LTE Band 5_1.4MHz_16QAM_20407_3RB#3





LTE Band 5_1.4MHz_QPSK_20407_6RB#0

LTE Band 5_1.4MHz_16QAM_20407_6RB#0



LTE Band 5_1.4MHz_QPSK_20643_1RB#0

LTE Band 5_1.4MHz_16QAM_20643_1RB#0



LTE Band 5_1.4MHz_QPSK_20643_1RB#2

LTE Band 5_1.4MHz_16QAM_20643_1RB#2

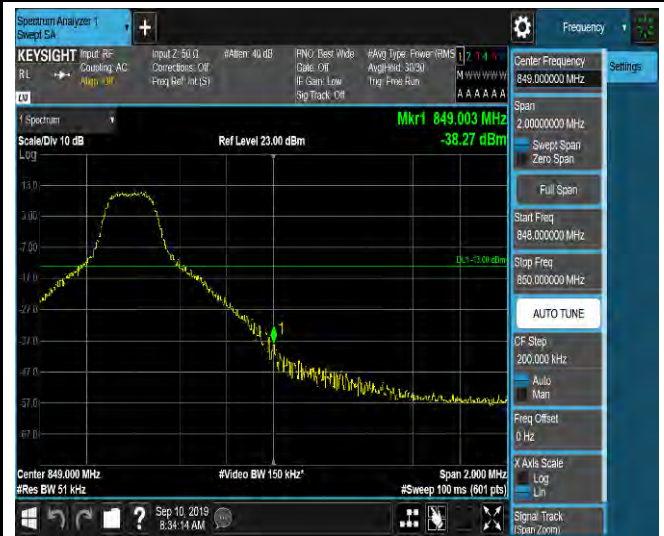
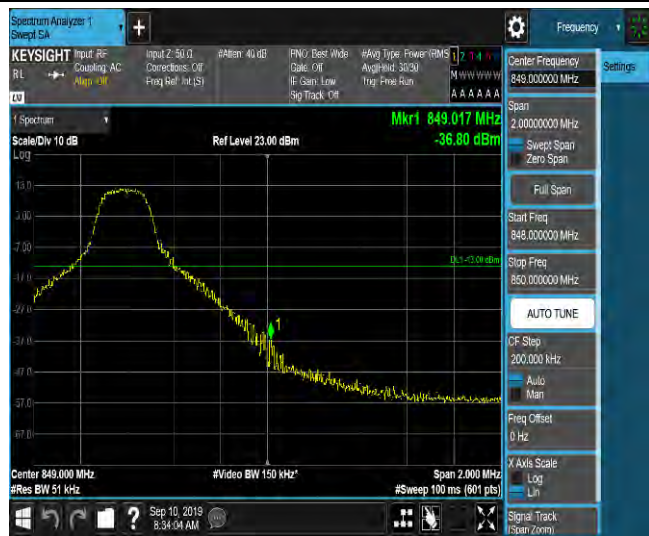



LTE Band 5_1.4MHz_QPSK_20643_1RB#5

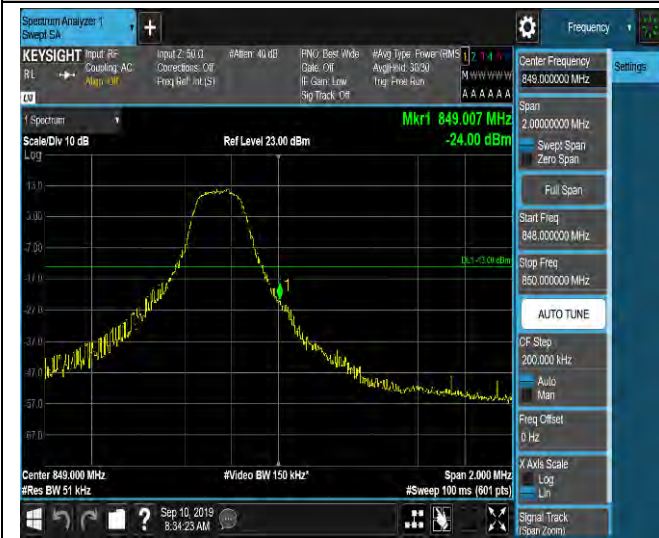

LTE Band 5_1.4MHz_16QAM_20643_1RB#5

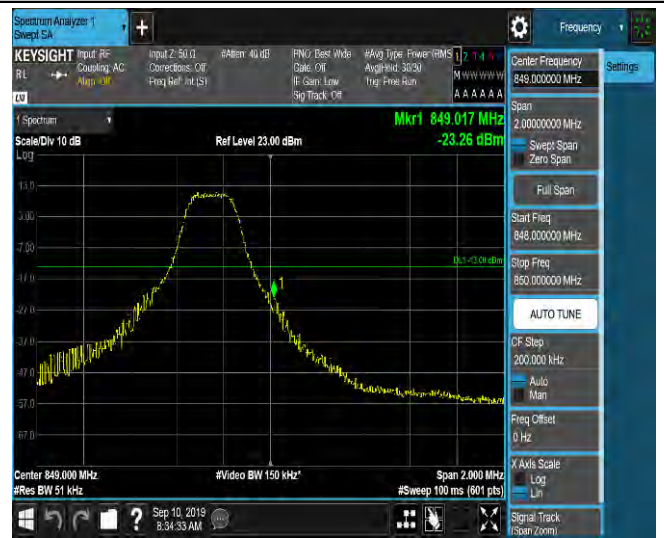

LTE Band 5_1.4MHz_QPSK_20643_3RB#0



LTE Band 5_1.4MHz_16QAM_20643_3RB#



LTE Band 5_1.4MHz_QPSK_20643_3RB#1



LTE Band 5_1.4MHz_16QAM_20643_3RB#1





LTE Band 5_1.4MHz_QPSK_20643_3RB#3



LTE Band 5_1.4MHz_16QAM_20643_3RB#3



LTE Band 5_1.4MHz_QPSK_20643_6RB#0



LTE Band 5_1.4MHz_16QAM_20643_6RB#0



LTE Band 5_3MHz_QPSK_20415_1RB#0

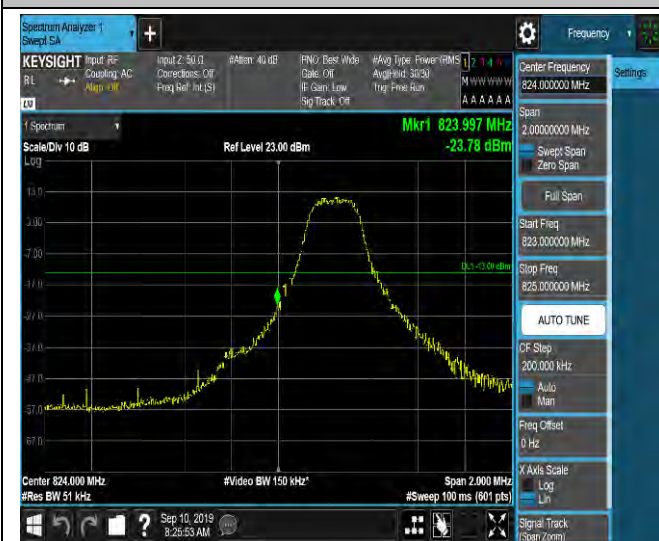

LTE Band 5_3MHz_16QAM_20415_1RB#0

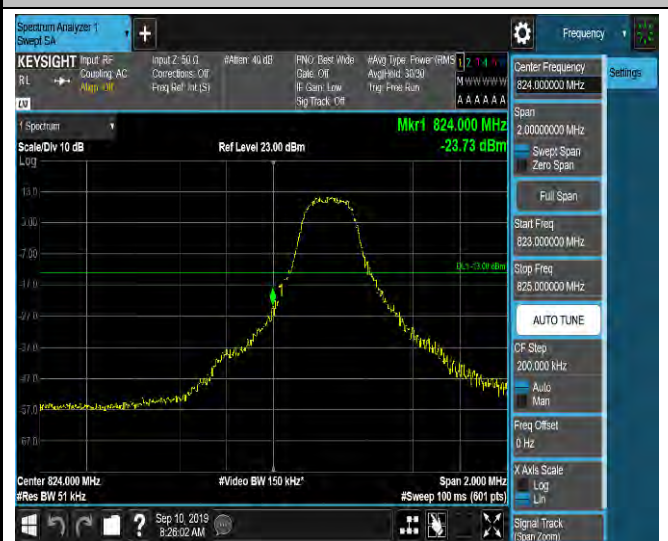



LTE Band 5_3MHz_QPSK_20415_1RB#8

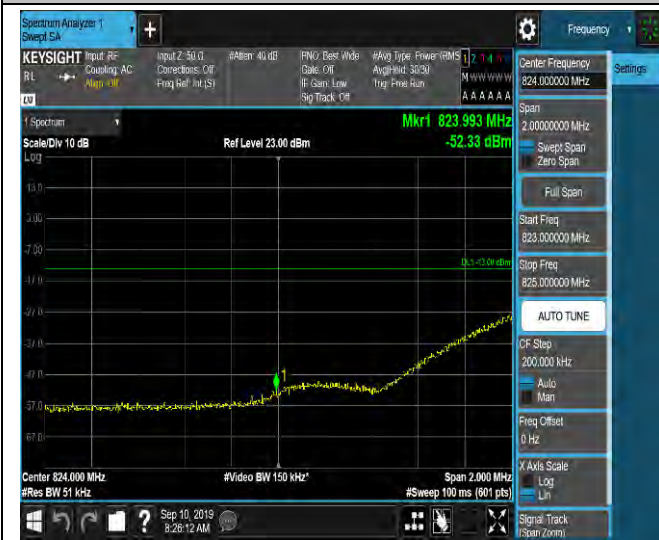

LTE Band 5_3MHz_16QAM_20415_1RB#8_-50.62



LTE Band 5_3MHz_QPSK_20415_1RB#14

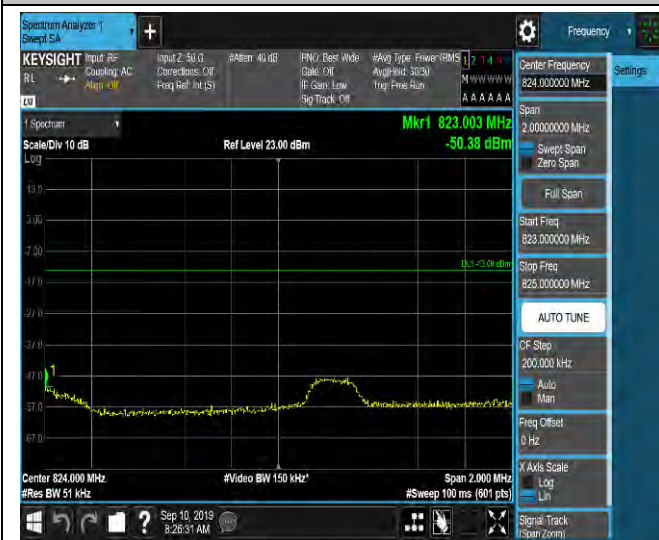

LTE Band 5_3MHz_16QAM_20415_1RB#14

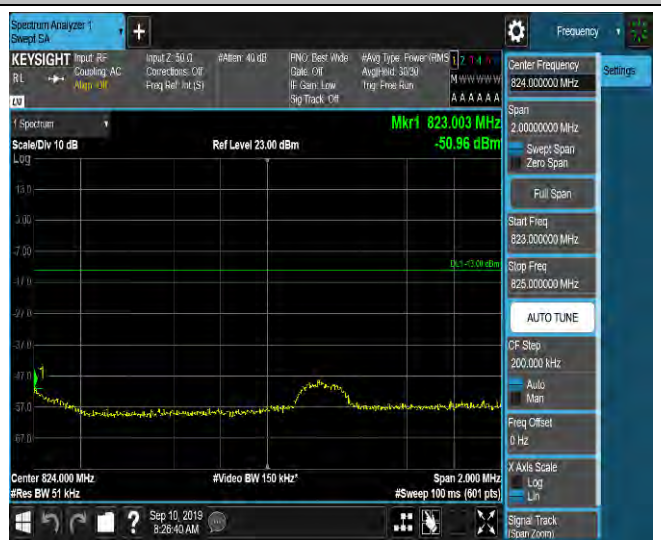

LTE Band 5_3MHz_QPSK_20415_8RB#0



LTE Band 5_3MHz_16QAM_20415_8RB#0

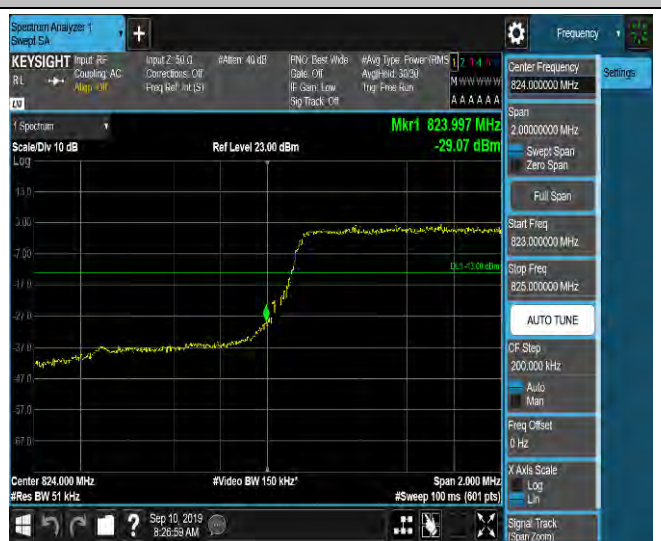



LTE Band 5_3MHz_QPSK_20415_8RB#4

LTE Band 5_3MHz_16QAM_20415_8RB#4



LTE Band 5_3MHz_QPSK_20415_8RB#7

LTE Band 5_3MHz_16QAM_20415_8RB#7



LTE Band 5_3MHz_QPSK_20415_15RB#0

LTE Band 5_3MHz_16QAM_20415_15RB#0





LTE Band 5_3MHz_QPSK_20635_1RB#0

LTE Band 5_3MHz_16QAM_20635_1RB#0

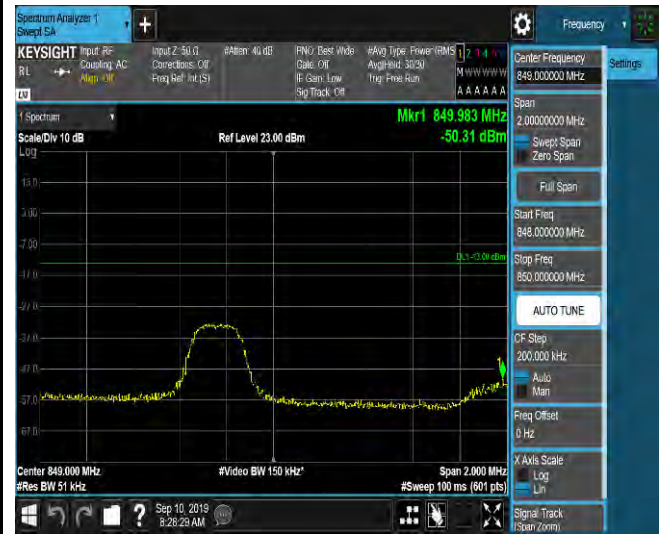
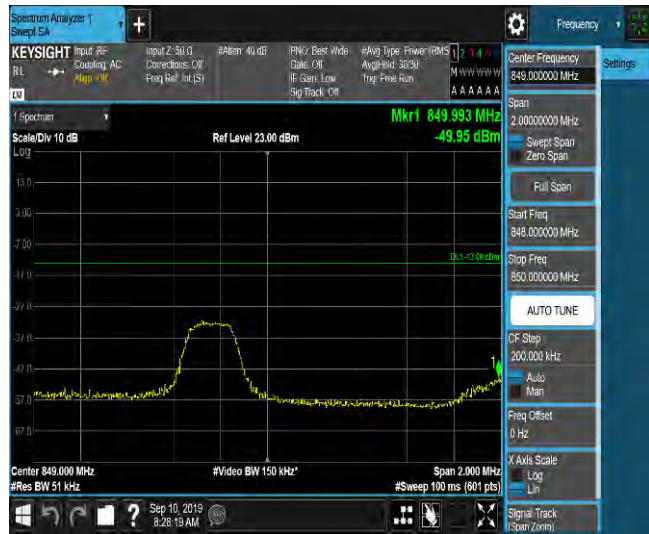

LTE Band 5_3MHz_QPSK_20635_1RB#8

LTE Band 5_3MHz_16QAM_20635_1RB#8

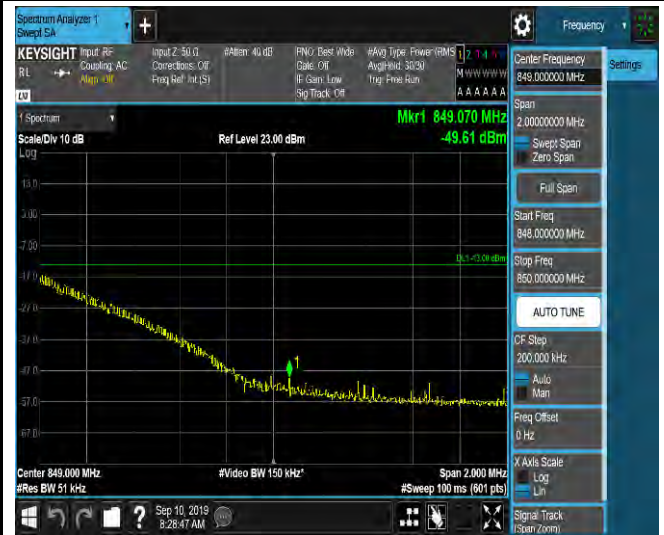

LTE Band 5_3MHz_QPSK_20635_1RB#14

LTE Band 5_3MHz_16QAM_20635_1RB#14

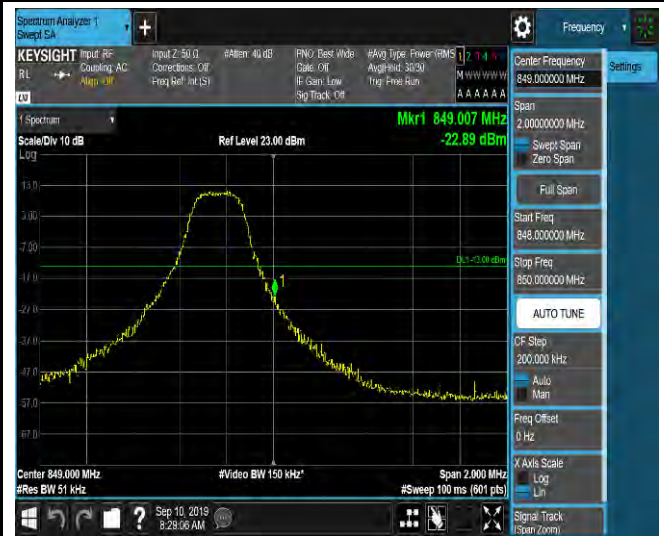
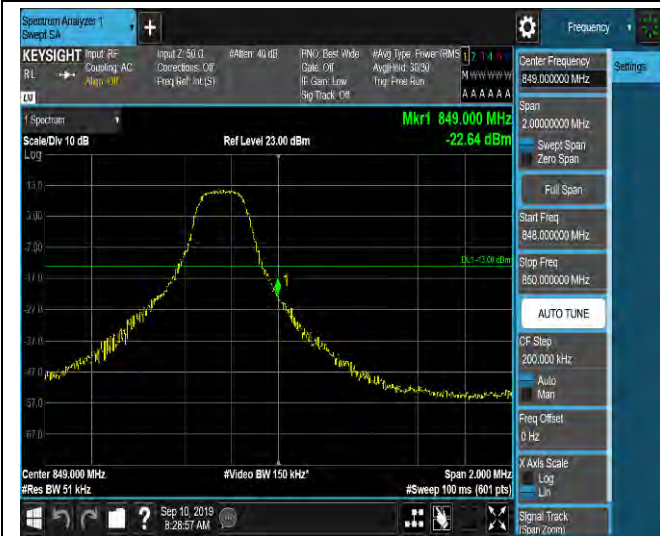



LTE Band 5_3MHz_QPSK_20635_8RB#

LTE Band 5_3MHz_16QAM_20635_8RB#0_-39.29



LTE Band 5_3MHz_QPSK_20635_8RB#4

LTE Band 5_3MHz_16QAM_20635_8RB#4_-39.03



LTE Band 5_3MHz_QPSK_20635_8RB#7

LTE Band 5_3MHz_16QAM_20635_8RB#7_-26.81





LTE Band 5_3MHz_QPSK_20635_15RB#0



LTE Band 5_3MHz_16QAM_20635_15RB#0



LTE Band 5_5MHz_QPSK_20425_1RB#0

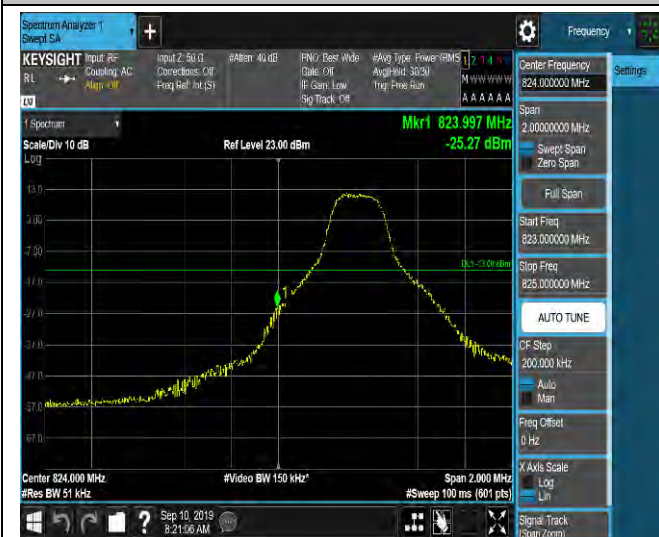

LTE Band 5_5MHz_16QAM_20425_1RB#0_-28.17

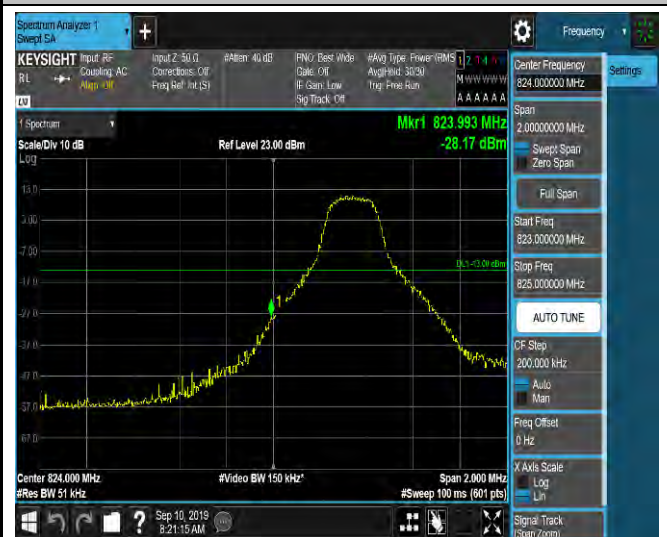

LTE Band 5_5MHz_QPSK_20425_1RB#12

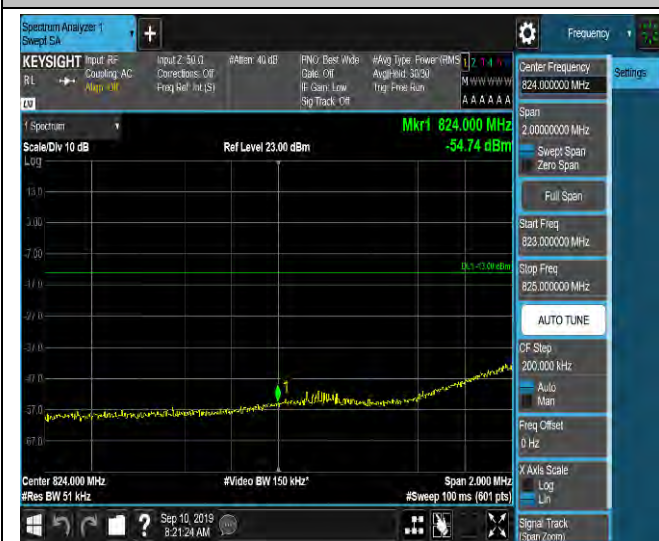

LTE Band 5_5MHz_16QAM_20425_1RB#12





LTE Band 5_5MHz_QPSK_20425_1RB#24

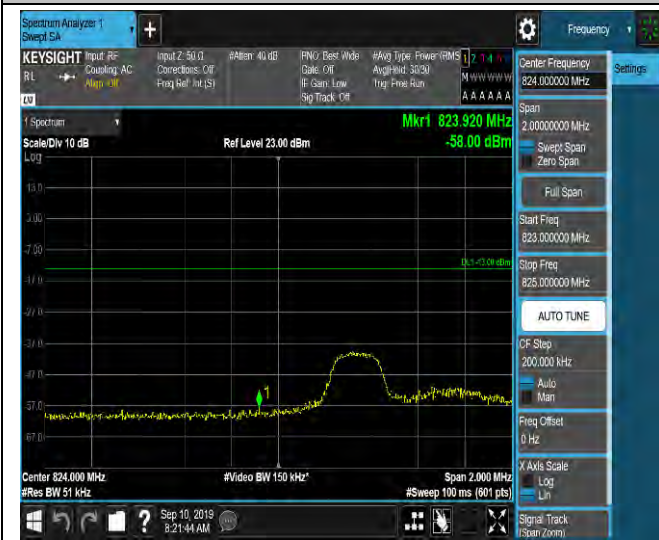

LTE Band 5_5MHz_16QAM_20425_1RB#24

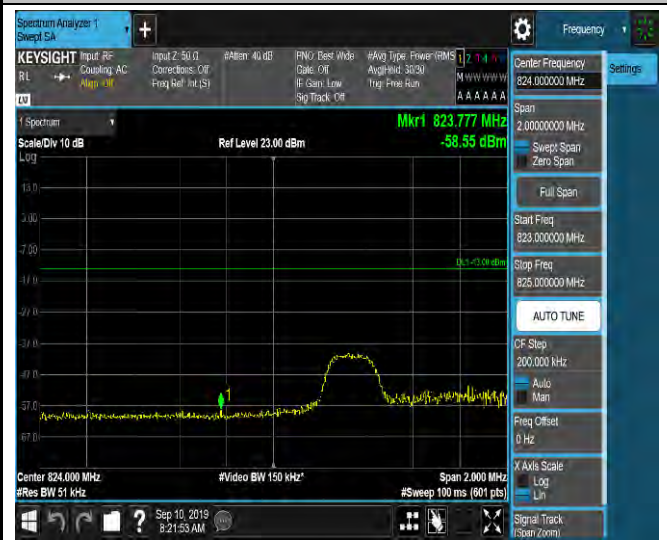

LTE Band 5_5MHz_QPSK_20425_12RB#0



LTE Band 5_5MHz_16QAM_20425_12RB#0



LTE Band 5_5MHz_QPSK_20425_12RB#6



LTE Band 5_5MHz_16QAM_20425_12RB#6





LTE Band 5_5MHz_QPSK_20425_12RB#13



LTE Band 5_5MHz_16QAM_20425_12RB#1



LTE Band 5_5MHz_QPSK_20425_25RB#0



LTE Band 5_5MHz_16QAM_20425_25RB#0



LTE Band 5_5MHz_QPSK_20625_1RB#0

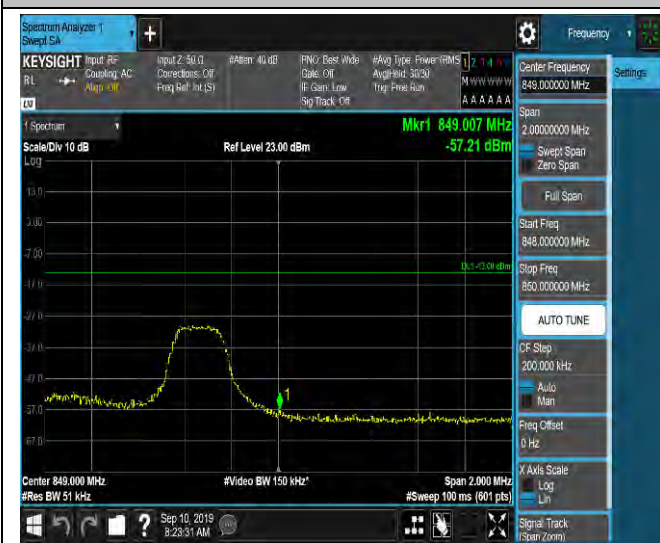

LTE Band 5_5MHz_16QAM_20625_1RB#0_

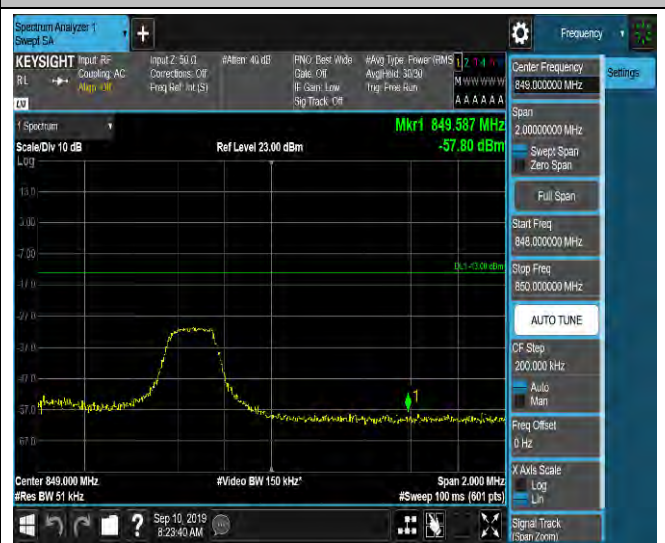



LTE Band 5_5MHz_QPSK_20625_1RB#12



LTE Band 5_5MHz_16QAM_20625_1RB#12

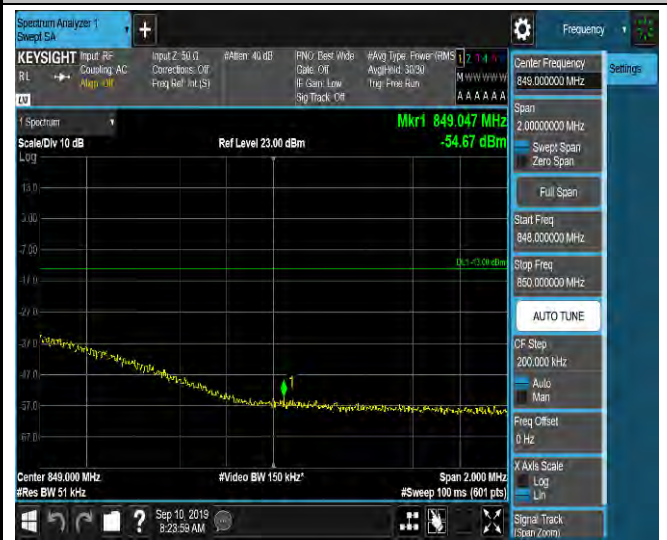

LTE Band 5_5MHz_QPSK_20625_1RB#24

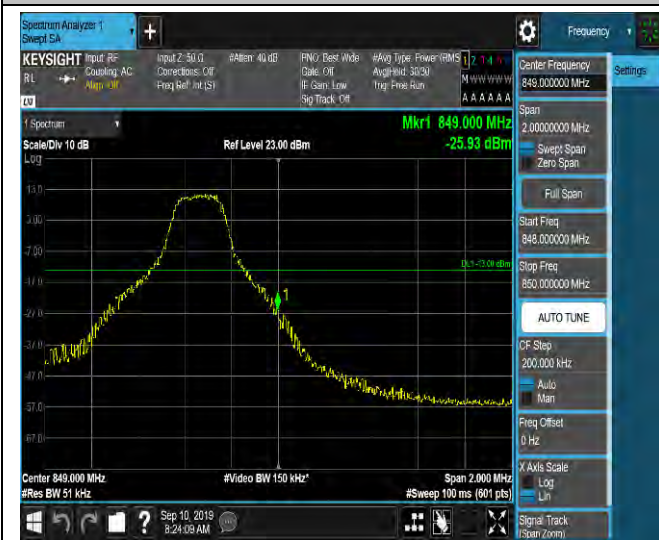

LTE Band 5_5MHz_16QAM_20625_1RB#24



LTE Band 5_5MHz_QPSK_20625_12RB#0

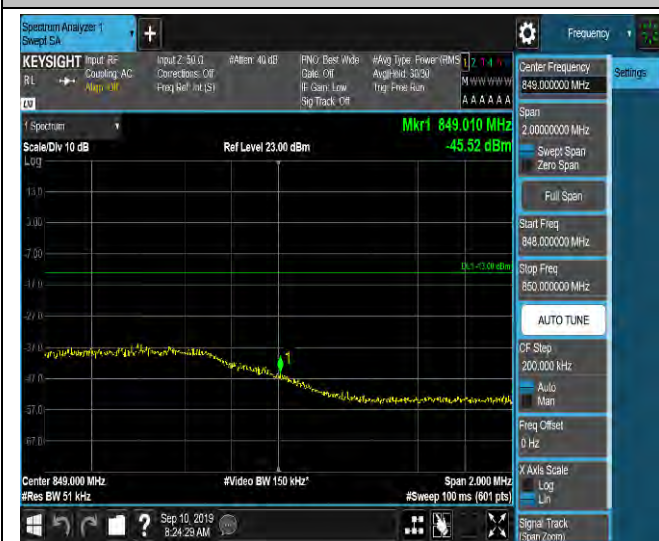

LTE Band 5_5MHz_16QAM_20625_12RB#0





LTE Band 5_5MHz_QPSK_20625_12RB#6



LTE Band 5_5MHz_16QAM_20625_12RB#6



LTE Band 5_5MHz_QPSK_20625_12RB#13

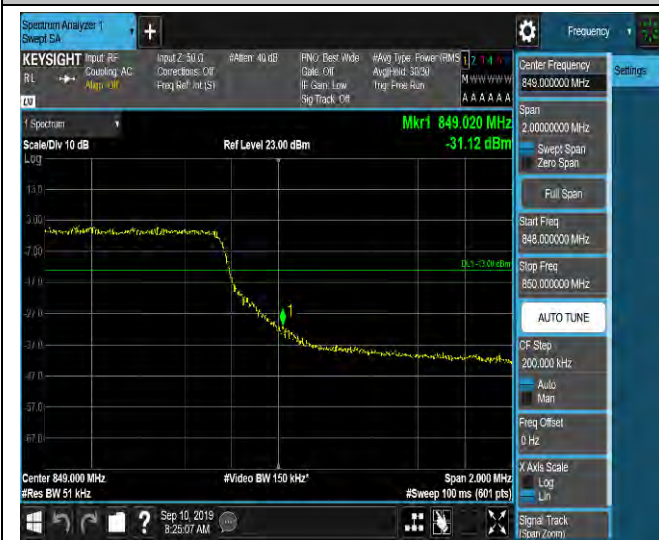

LTE Band 5_5MHz_16QAM_20625_12RB#13



LTE Band 5_5MHz_QPSK_20625_25RB#0



LTE Band 5_5MHz_16QAM_20625_25RB#0





LTE Band 5_10MHz_QPSK_20450_1RB#0

LTE Band 5_10MHz_16QAM_20450_1RB#0



LTE Band 5_10MHz_QPSK_20450_1RB#24

LTE Band 5_10MHz_16QAM_20450_1RB#24

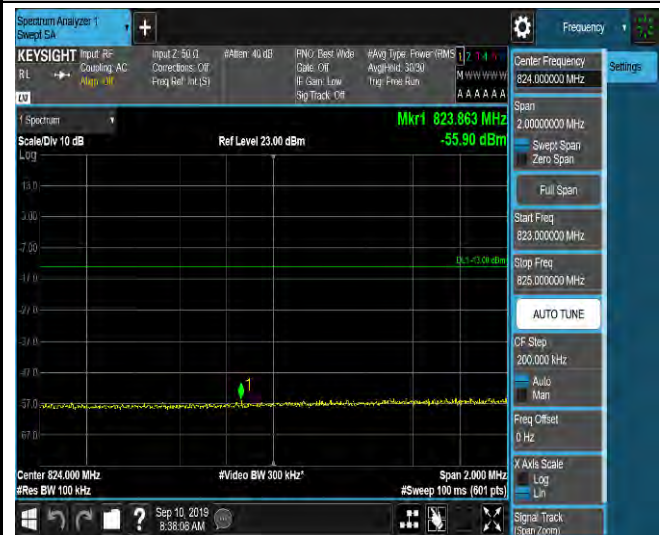

LTE Band 5_10MHz_QPSK_20450_1RB#49

LTE Band 5_10MHz_16QAM_20450_1RB#49

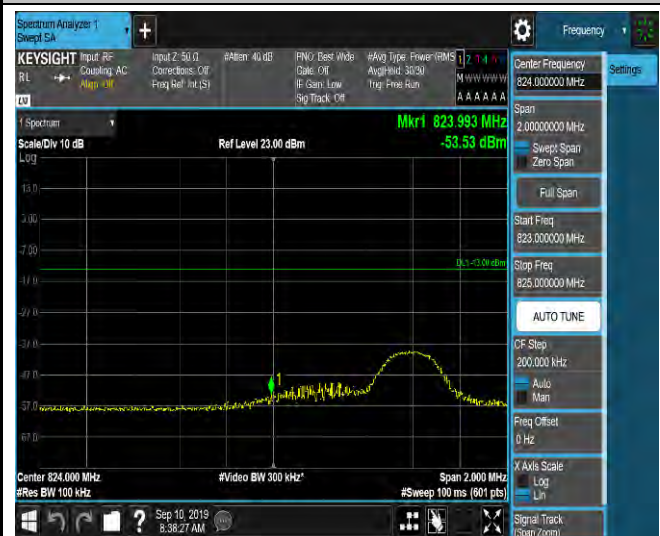
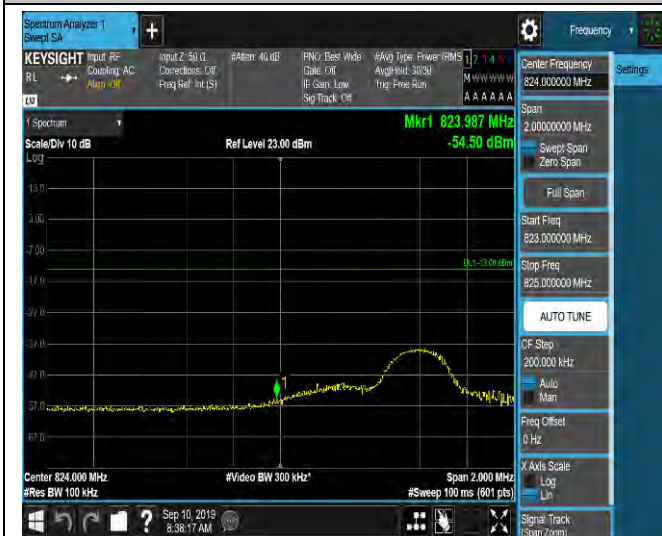



LTE Band 5_10MHz_QPSK_20450_25RB#0

LTE Band 5_10MHz_16QAM_20450_25RB#0



LTE Band 5_10MHz_QPSK_20450_25RB#1

LTE Band 5_10MHz_16QAM_20450_25RB#12



LTE Band 5_10MHz_QPSK_20450_25RB#25

LTE Band 5_10MHz_16QAM_20450_25RB#25

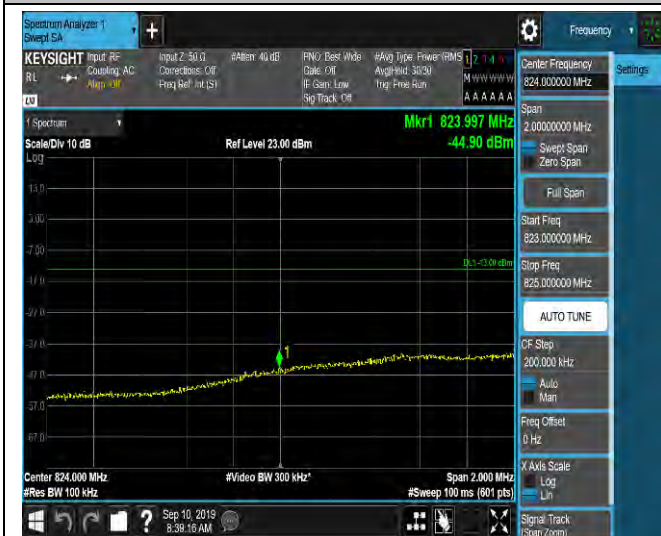



LTE Band 5_10MHz_QPSK_20450_50RB#0

LTE Band 5_10MHz_16QAM_20450_50RB#0



LTE Band 5_10MHz_QPSK_20600_1RB#0

LTE Band 5_10MHz_16QAM_20600_1RB#0

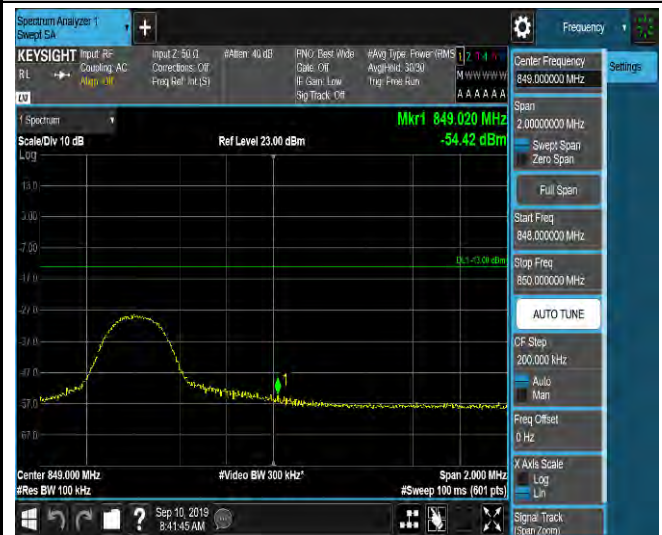

LTE Band 5_10MHz_QPSK_20600_1RB#24

LTE Band 5_10MHz_16QAM_20600_1RB#24





LTE Band 5_10MHz_QPSK_20600_1RB#49



LTE Band 5_10MHz_16QAM_20600_1RB#49



LTE Band 5_10MHz_QPSK_20600_25RB#0



LTE Band 5_10MHz_16QAM_20600_25RB#0



LTE Band 5_10MHz_QPSK_20600_25RB#12



LTE Band 5_10MHz_16QAM_20600_25RB#12





LTE Band 5_10MHz_QPSK_20600_25RB#25

LTE Band 5_10MHz_16QAM_20600_25RB#25



LTE Band 5_10MHz_QPSK_20600_50RB#0

LTE Band 5_10MHz_16QAM_20600_50RB#0



5.5. Peak-to-Average Power Ratio (PAPR)

Ambient condition

Temperature	Relative humidity	Pressure
23°C ~25°C	45%~50%	101.5kPa

Methods of Measurement

Measure the total peak power and record as P_{Pk} . And measure the total average power and record as P_{Avg} . Both the peak and average power levels must be expressed in the same logarithmic units (e.g., dBm). Determine the PAPR from:

$$PAPR (dB) = P_{Pk} (dBm) - P_{Avg} (dBm).$$

Test Setup

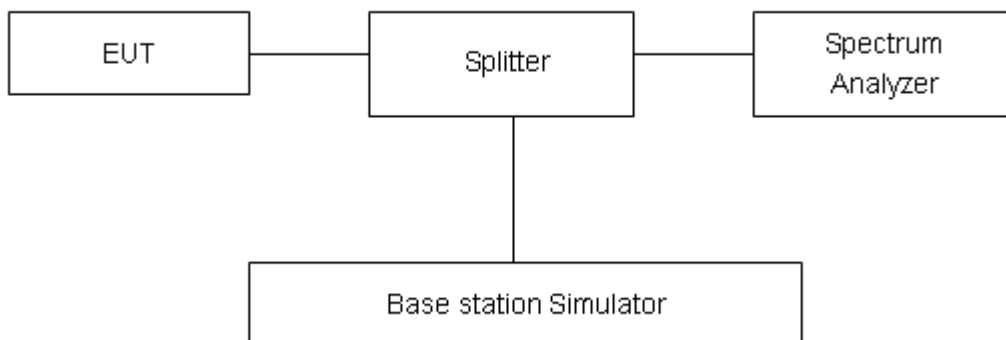

Limits

According to the Sec. 22.913(d), The peak-to-average ratio (PAR) of the transmission must not exceed 13 dB.

Measurement Uncertainty

The assessed measurement uncertainty to ensure 95% confidence level for the normal distribution is with the coverage factor $k = 2$, $U = 0.4$ dB.



Test Results

Band	Channel	Peak-to-Average Ratio(dB)	Limit(dBm)	Verdict
GPRS850	128	2.65	13	PASS
GPRS850	190	2.65	13	PASS
GPRS850	251	2.66	13	PASS
EGPRS850	128	5.69	13	PASS
EGPRS850	190	5.64	13	PASS
EGPRS850	251	5.63	13	PASS
Band	Channel	Peak-to-Average Ratio(dB)	Limit(dBm)	Verdict
WCDMA Band V	4132	3.11	13	PASS
WCDMA Band V	4182	3.18	13	PASS
WCDMA Band V	4233	3.14	13	PASS

Band	Bandwidth	Modulation	Channel	RB Configuration	Result (dB)	Limit (dB)	Verdict
LTE Band 5	1.4MHz	QPSK	20407	6RB#0	5.07	13	PASS
LTE Band 5	1.4MHz	16QAM	20407	6RB#0	5.14	13	PASS
LTE Band 5	1.4MHz	QPSK	20525	6RB#0	5.34	13	PASS
LTE Band 5	1.4MHz	16QAM	20525	6RB#0	5.31	13	PASS
LTE Band 5	1.4MHz	QPSK	20643	6RB#0	5.22	13	PASS
LTE Band 5	1.4MHz	16QAM	20643	6RB#0	5.23	13	PASS
LTE Band 5	3MHz	QPSK	20415	15RB#0	5.04	13	PASS
LTE Band 5	3MHz	16QAM	20415	15RB#0	5.07	13	PASS
LTE Band 5	3MHz	QPSK	20525	15RB#0	5.35	13	PASS
LTE Band 5	3MHz	16QAM	20525	15RB#0	5.38	13	PASS
LTE Band 5	3MHz	QPSK	20635	15RB#0	5.20	13	PASS
LTE Band 5	3MHz	16QAM	20635	15RB#0	5.22	13	PASS
LTE Band 5	5MHz	QPSK	20425	25RB#0	5.10	13	PASS
LTE Band 5	5MHz	16QAM	20425	25RB#0	5.10	13	PASS
LTE Band 5	5MHz	QPSK	20525	25RB#0	5.30	13	PASS
LTE Band 5	5MHz	16QAM	20525	25RB#0	5.30	13	PASS
LTE Band 5	5MHz	QPSK	20625	25RB#0	5.24	13	PASS
LTE Band 5	5MHz	16QAM	20625	25RB#0	5.23	13	PASS
LTE Band 5	10MHz	QPSK	20450	50RB#0	5.11	13	PASS
LTE Band 5	10MHz	16QAM	20450	50RB#0	5.12	13	PASS
LTE Band 5	10MHz	QPSK	20525	50RB#0	5.19	13	PASS
LTE Band 5	10MHz	16QAM	20525	50RB#0	5.19	13	PASS
LTE Band 5	10MHz	QPSK	20600	50RB#0	5.16	13	PASS
LTE Band 5	10MHz	16QAM	20600	50RB#0	5.17	13	PASS

5.6. Frequency Stability

Ambient condition

Temperature	Relative humidity	Pressure
23°C ~25°C	45%~50%	101.5kPa

Method of Measurement

Frequency Stability (Temperature Variation)

The temperature inside the climate chamber is varied from -40°C to +85°C in 10°C step size,

(1) With all power removed, the temperature was decreased to 0°C and permitted to stabilize for three hours.

(2) Measure the carrier frequency with the test equipment in a “call mode”. These measurements should be made within 1 minute of powering up the mobile station, to prevent significant self warming.

(3) Repeat the above measurements at 10°C increments from -40°C to +85°C. Allow at least 1.5 hours at each temperature, un-powered, before making measurements.

Frequency Stability (Voltage Variation)

The frequency stability shall be measured with variation of primary supply voltage as follows:

(1) Vary primary supply voltage from 85 to 115 percent of the nominal value for other than hand carried battery equipment.

(2) For hand carried, battery powered equipment, reduce primary supply voltage to the battery-operating end point which shall be specified by the manufacturer.

This transceiver is specified to operate with an input voltage of between 3.3 V and 4.3 V, with a nominal voltage of 3.8V.

Test setup

