

**Limits**

According to the Sec. 22.355, the frequency stability of the carrier shall be accurate to within 2.5 ppm of the received frequency for mobile stations.

Limits	≤ 2.5 ppm
--------	----------------

Measurement Uncertainty

The assessed measurement uncertainty to ensure 99.75% confidence level for the normal distribution is with the coverage factor $k = 3$, $U = 0.01$ ppm.

Test Result

GSM850						
Condition		Freq.Error (Hz)	Freq.Error (Hz)	Frequency Stability (ppm)	Frequency Stability (ppm)	Verdict
Temperature	Voltage	GMSK	8PSK	GMSK	8PSK	
Normal (25°C)	Normal	7.37	6.71	0.00392	0.00357	PASS
Extreme (85°C)		2.35	7.08	0.00125	0.00377	PASS
Extreme (80°C)		13.18	17.51	0.00701	0.00932	PASS
Extreme (70°C)		4.34	1.05	0.00231	0.00056	PASS
Extreme (60°C)		17.38	8.01	0.00925	0.00426	PASS
Extreme (50°C)		1.97	12.17	0.00105	0.00648	PASS
Extreme (40°C)		15.66	13.56	0.00833	0.00721	PASS
Extreme (30°C)		14.96	7.25	0.00796	0.00386	PASS
Extreme (20°C)		7.92	9.05	0.00421	0.00482	PASS
Extreme (10°C)		9.83	17.48	0.00523	0.00930	PASS
Extreme (0°C)		3.74	13.28	0.00199	0.00707	PASS
Extreme (-10°C)		8.24	7.01	0.00438	0.00373	PASS
Extreme (-20°C)		13.47	6.15	0.00716	0.00327	PASS
Extreme (-30°C)		10.46	15.34	0.00557	0.00816	PASS
Extreme (-40°C)		2.03	3.13	0.00108	0.00167	PASS
25°C		LV	8.89	12.49	0.00473	0.00665
	HV	14.56	2.87	0.00775	0.00153	PASS



WCDMA B5						
Condition		Freq.Error (Hz)	Freq.Error (Hz)	Frequency Stability (ppm)	Frequency Stability (ppm)	Verdict
Temperature	Voltage	BPSK	QPSK	BPSK	QPSK	
Normal (25°C)	Normal	2.57	1.06	0.00137	0.00056	PASS
Extreme (85°C)		5.58	1.72	0.00297	0.00091	PASS
Extreme (80°C)		14.34	11.64	0.00763	0.00619	PASS
Extreme (70°C)		15.48	4.63	0.00823	0.00247	PASS
Extreme (60°C)		13.38	15.18	0.00712	0.00807	PASS
Extreme (50°C)		5.20	7.88	0.00277	0.00419	PASS
Extreme (40°C)		8.98	13.73	0.00477	0.00730	PASS
Extreme (30°C)		8.73	9.58	0.00464	0.00509	PASS
Extreme (20°C)		11.02	7.99	0.00586	0.00425	PASS
Extreme (10°C)		3.70	16.55	0.00197	0.00880	PASS
Extreme (0°C)		10.92	13.50	0.00581	0.00718	PASS
Extreme (-10°C)		10.47	5.92	0.00557	0.00315	PASS
Extreme (-20°C)		1.66	2.49	0.00088	0.00132	PASS
Extreme (-30°C)		17.75	8.42	0.00944	0.00448	PASS
Extreme (-40°C)		17.60	3.04	0.00936	0.00162	PASS
25°C	LV	6.97	17.47	0.00371	0.00929	PASS
	HV	2.71	1.60	0.00144	0.00085	PASS

LTE Band 5						
Condition		Freq.Error (Hz)	Freq.Error (Hz)	Frequency Stability (ppm)	Frequency Stability (ppm)	Verdict
BANDWIDTH	1.4MHz					
Temperature	Voltage	16QAM	QPSK	16QAM	QPSK	
Normal (25°C)	Normal	9.44	6.37	0.00502	0.00339	PASS
Extreme (85°C)		12.19	15.80	0.00648	0.00840	PASS
Extreme (80°C)		2.55	13.79	0.00136	0.00733	PASS
Extreme (70°C)		5.73	10.91	0.00305	0.00580	PASS
Extreme (60°C)		12.25	8.65	0.00651	0.00460	PASS
Extreme (50°C)		10.51	10.97	0.00559	0.00584	PASS
Extreme (40°C)		6.52	8.18	0.00347	0.00435	PASS
Extreme (30°C)		11.93	11.03	0.00634	0.00587	PASS
Extreme (20°C)		2.90	6.48	0.00154	0.00345	PASS
Extreme (10°C)		16.93	2.32	0.00900	0.00123	PASS
Extreme (0°C)		15.99	13.94	0.00851	0.00741	PASS
Extreme (-10°C)		17.02	4.52	0.00905	0.00241	PASS



Extreme (-20°C)		3.15	1.50	0.00168	0.00080	PASS
Extreme (-30°C)		4.55	17.35	0.00242	0.00923	PASS
Extreme (-40°C)		14.36	11.36	0.00764	0.00604	PASS
25°C	LV	4.34	5.25	0.00231	0.00279	PASS
	HV	7.94	1.82	0.00422	0.00097	PASS
Condition		Freq.Error (Hz)	Freq.Error (Hz)	Frequency Stability (ppm)	Frequency Stability (ppm)	Verdict
BANDWIDTH	3MHz					
Temperature	Voltage	16QAM	QPSK	16QAM	QPSK	
Normal (25°C)	Normal	3.55	8.95	0.00189	0.00476	PASS
Extreme (85°C)		12.34	4.84	0.00656	0.00258	PASS
Extreme (80°C)		14.43	3.80	0.00768	0.00202	PASS
Extreme (70°C)		2.98	11.76	0.00158	0.00626	PASS
Extreme (60°C)		14.94	6.35	0.00795	0.00338	PASS
Extreme (50°C)		4.44	10.32	0.00236	0.00549	PASS
Extreme (40°C)		6.73	13.04	0.00358	0.00693	PASS
Extreme (30°C)		9.89	3.93	0.00526	0.00209	PASS
Extreme (20°C)		7.78	8.50	0.00414	0.00452	PASS
Extreme (10°C)		2.54	16.58	0.00135	0.00882	PASS
Extreme (0°C)		14.47	11.79	0.00769	0.00627	PASS
Extreme (-10°C)		16.09	7.77	0.00856	0.00413	PASS
Extreme (-20°C)		3.29	7.72	0.00175	0.00411	PASS
Extreme (-30°C)		12.62	9.98	0.00671	0.00531	PASS
Extreme (-40°C)		16.55	17.79	0.00880	0.00946	PASS
25°C	LV	1.00	14.43	0.00053	0.00768	PASS
	HV	16.31	2.87	0.00868	0.00152	PASS
Condition		Freq.Error (Hz)	Freq.Error (Hz)	Frequency Stability (ppm)	Frequency Stability (ppm)	Verdict
BANDWIDTH	5MHz					
Temperature	Voltage	16QAM	QPSK	16QAM	QPSK	
Normal (25°C)	Normal	17.65	11.93	0.00939	0.00635	PASS
Extreme (85°C)		16.10	3.02	0.00856	0.00161	PASS
Extreme (80°C)		11.27	15.11	0.00600	0.00804	PASS
Extreme (70°C)		3.60	17.02	0.00192	0.00906	PASS
Extreme (60°C)		8.51	7.38	0.00453	0.00392	PASS
Extreme (50°C)		2.08	15.96	0.00111	0.00849	PASS
Extreme (40°C)		7.49	3.79	0.00399	0.00202	PASS
Extreme (30°C)		1.94	5.52	0.00103	0.00294	PASS
Extreme (20°C)		1.32	5.91	0.00070	0.00315	PASS
Extreme (10°C)		4.49	16.02	0.00239	0.00852	PASS
Extreme (0°C)		4.51	4.32	0.00240	0.00230	PASS



Extreme (-10°C)		14.53	4.27	0.00773	0.00227	PASS
Extreme (-20°C)		3.11	12.33	0.00165	0.00656	PASS
Extreme (-30°C)		17.42	5.38	0.00927	0.00286	PASS
Extreme (-40°C)		16.64	1.08	0.00885	0.00058	PASS
25°C	LV	14.97	16.76	0.00796	0.00892	PASS
	HV	10.58	11.36	0.00563	0.00604	PASS
Condition		Freq.Error (Hz)	Freq.Error (Hz)	Frequency Stability (ppm)	Frequency Stability (ppm)	Verdict
BANDWIDTH	10MHz					
Temperature	Voltage	16QAM	QPSK	16QAM	QPSK	
Normal (25°C)	Normal	9.08	6.85	0.00483	0.00364	PASS
Extreme (85°C)		11.93	7.12	0.00634	0.00379	PASS
Extreme (80°C)		10.60	16.35	0.00564	0.00870	PASS
Extreme (70°C)		15.36	17.93	0.00817	0.00954	PASS
Extreme (60°C)		10.29	11.29	0.00547	0.00601	PASS
Extreme (50°C)		8.52	9.62	0.00453	0.00512	PASS
Extreme (40°C)		15.64	14.51	0.00832	0.00772	PASS
Extreme (30°C)		3.62	4.11	0.00192	0.00219	PASS
Extreme (20°C)		5.68	13.52	0.00302	0.00719	PASS
Extreme (10°C)		7.04	3.57	0.00375	0.00190	PASS
Extreme (0°C)		14.90	13.30	0.00793	0.00708	PASS
Extreme (-10°C)		2.63	15.91	0.00140	0.00846	PASS
Extreme (-20°C)		16.33	10.51	0.00869	0.00559	PASS
Extreme (-30°C)		7.89	14.53	0.00420	0.00773	PASS
Extreme (-40°C)		13.32	10.26	0.00709	0.00546	PASS
25°C	LV	15.69	1.64	0.00835	0.00087	PASS
	HV	9.64	1.01	0.00513	0.00054	PASS

5.7. Spurious Emissions at Antenna Terminals

Ambient condition

Temperature	Relative humidity	Pressure
23°C ~25°C	45%~50%	101.5kPa

Method of Measurement

The EUT was connected to Spectrum Analyzer and Base Station Simulator via power Splitter. The measurement is carried out using a spectrum analyzer. The spectrum analyzer scans from 9kHz to the 10th harmonic of the carrier.

The peak detector is used. RBW are set to 100 kHz and VBW are set to 300 kHz for below 1G, RBW are set to 1MHz and VBW are set to 3MHz for above 1G, Sweep is set to ATUO.

The modulation mode and RB allocation refer to section 5.1, using the maximum output power configuration.

Test setup

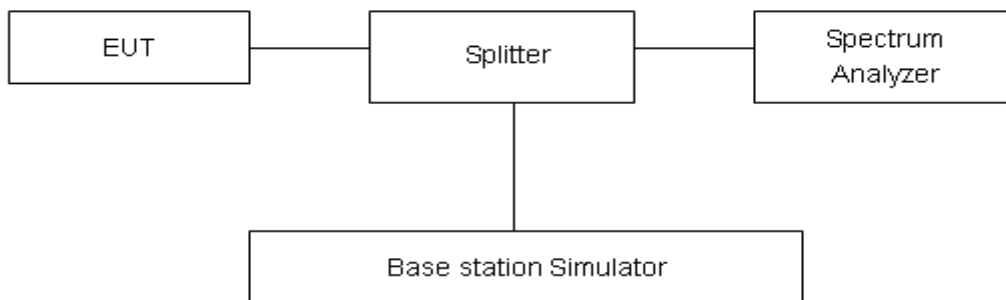

Limits

Rule Part 22.917(a) specifies that “The power of any emission outside of the authorized operating frequency ranges must be attenuated below the transmitting power (P) by a factor of at least 43 + 10 log (P) dB.”

Limit	-13 dBm
-------	---------

Measurement Uncertainty

The assessed measurement uncertainty to ensure 99.75% confidence level for the normal distribution is with the coverage factor $k = 1.96$.

Frequency	Uncertainty
9kHz-1GHz	0.684 dB
1GHz-18GHz	1.407 dB

Test Result

Sweep the whole frequency band through the range from 9kHz to the 10th harmonic of the carrier, the emissions more than 20 dB below the limit are not reported.

The signal beyond the limit is carrier.

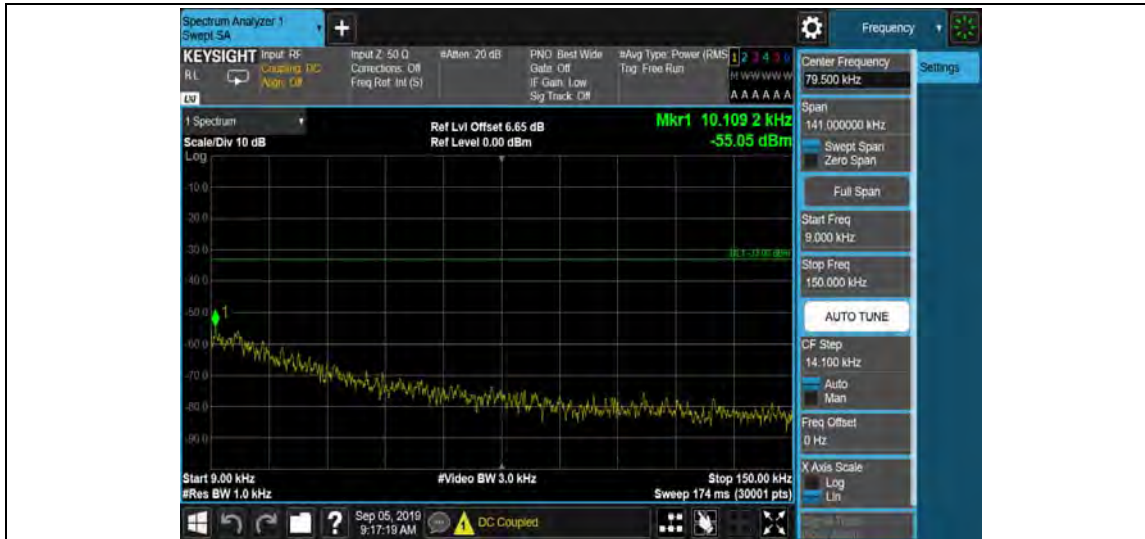

GPRS850-128-0.009~0.15

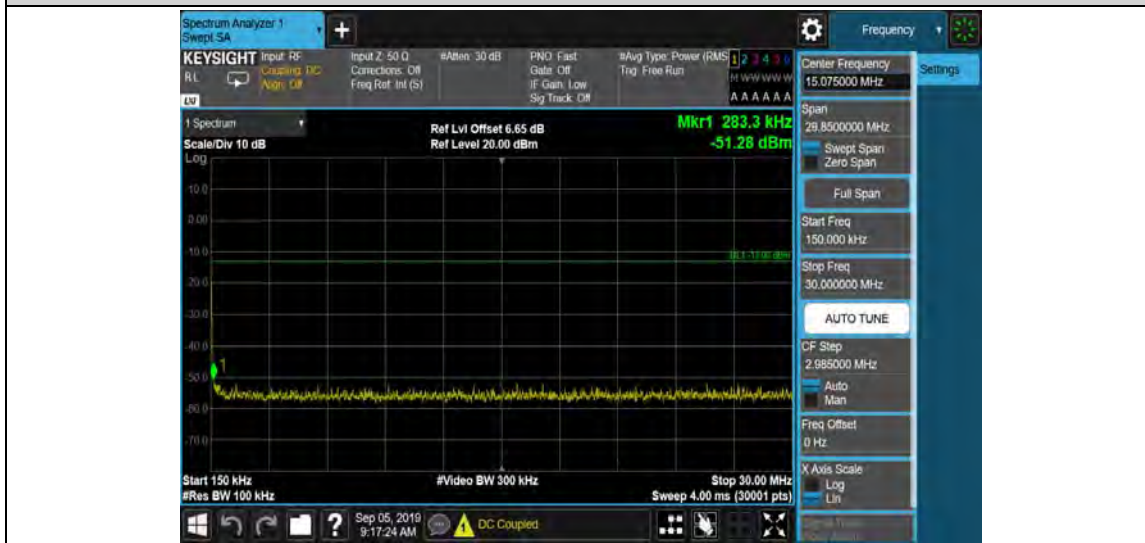

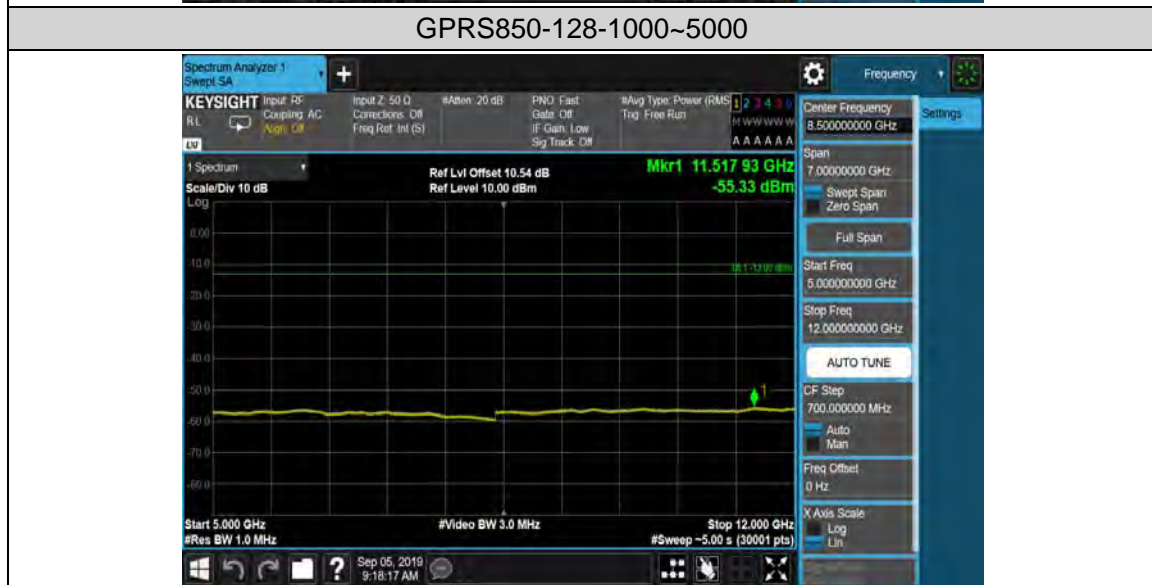
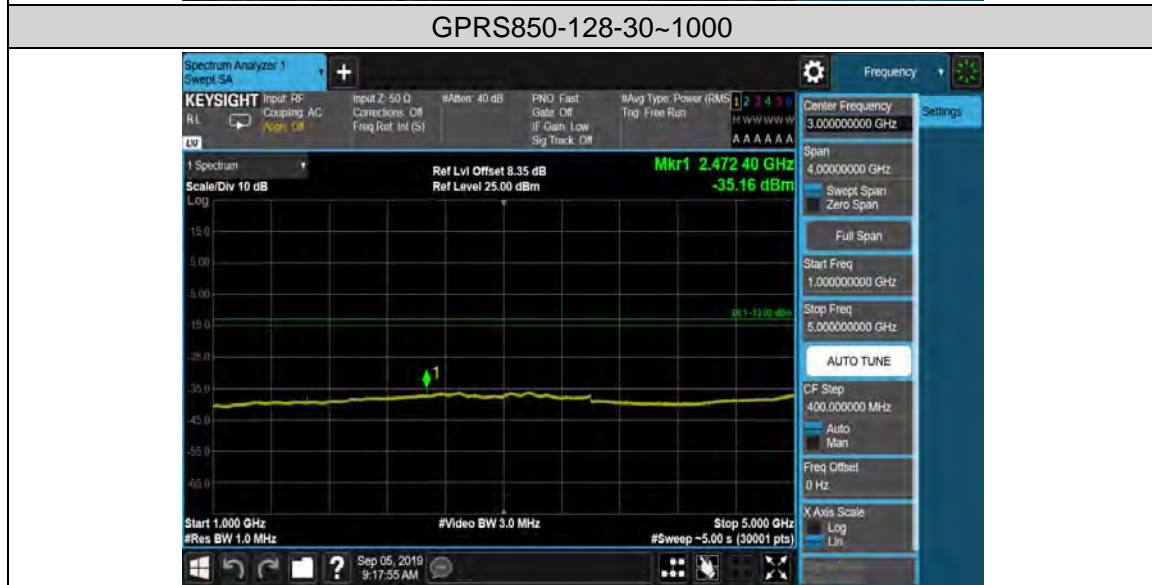
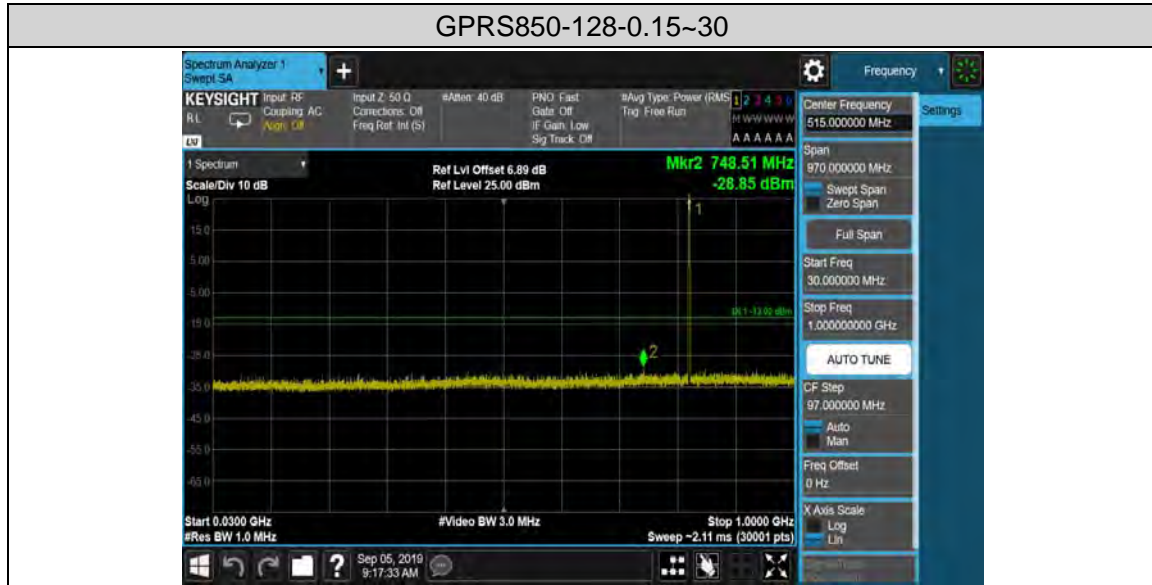



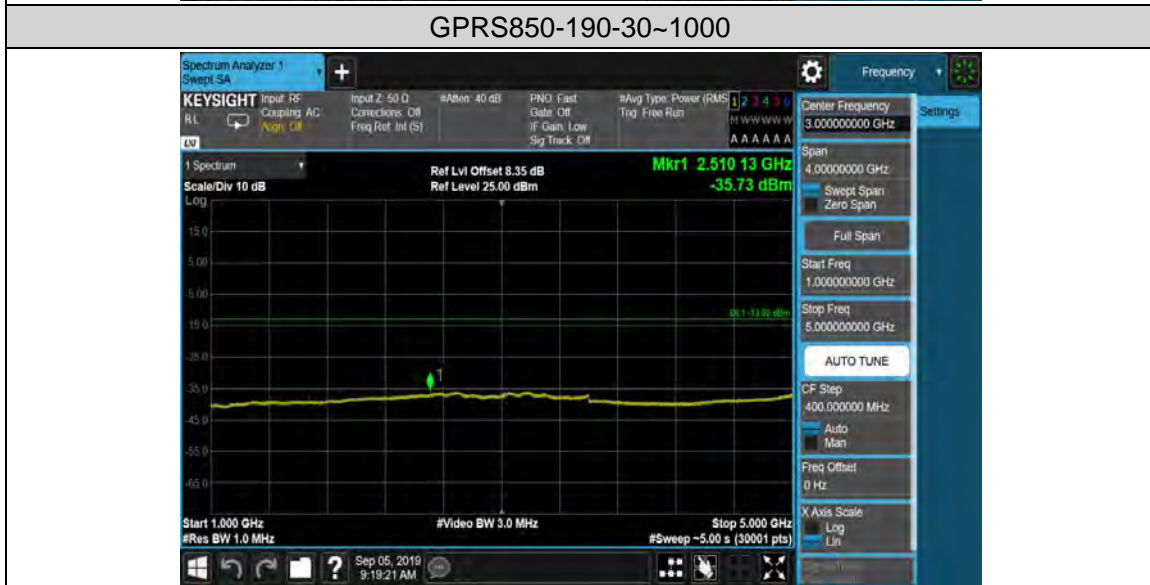

GPRS850-190-5000~12000



GPRS850-190-12000~18000

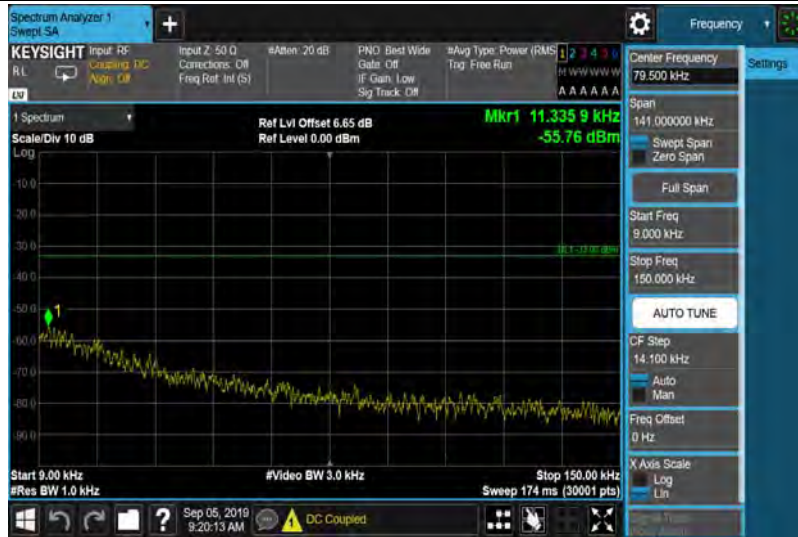

GPRS850-251-0.009~0.15

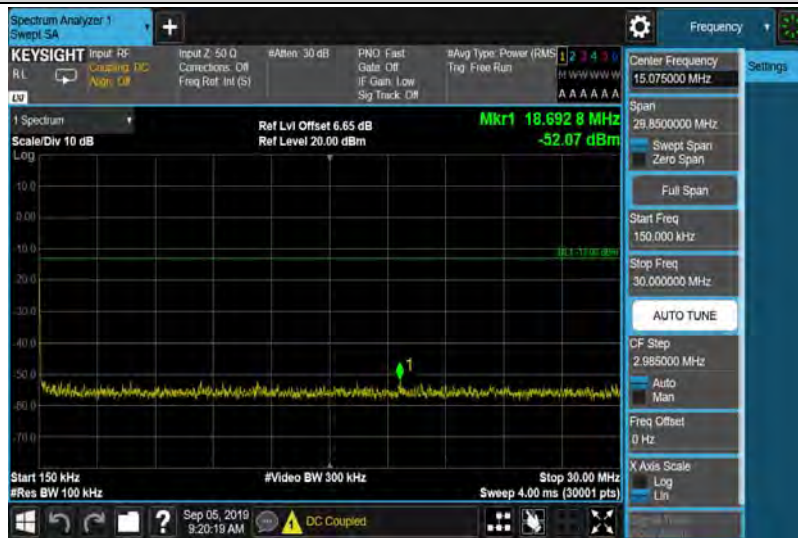



GPRS850-251-5000~12000



GPRS850-251-12000~18000



EGPRS850-128-0.009~0.15

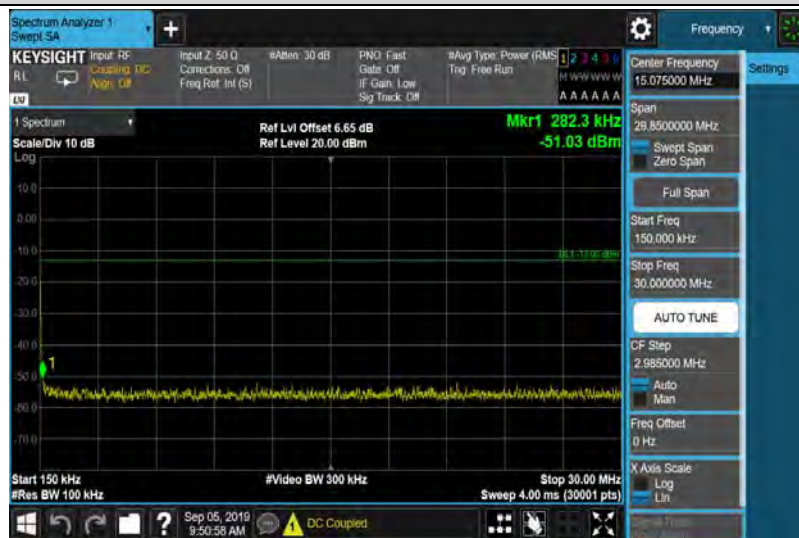

EGPRS850-128-0.15~30

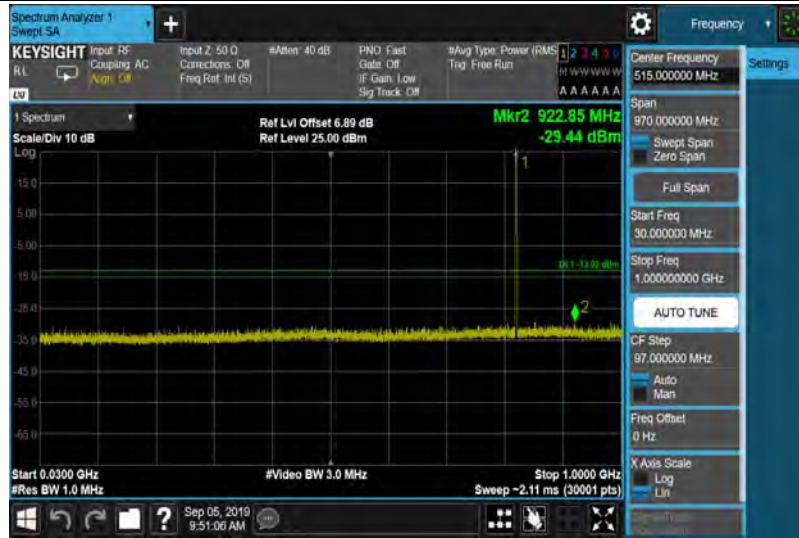

EGPRS850-128-30~1000



EGPRS850-128-1000~5000



EGPRS850-128-5000~12000



EGPRS850-128-12000~18000



EGPRS850-190-0.009~0.15

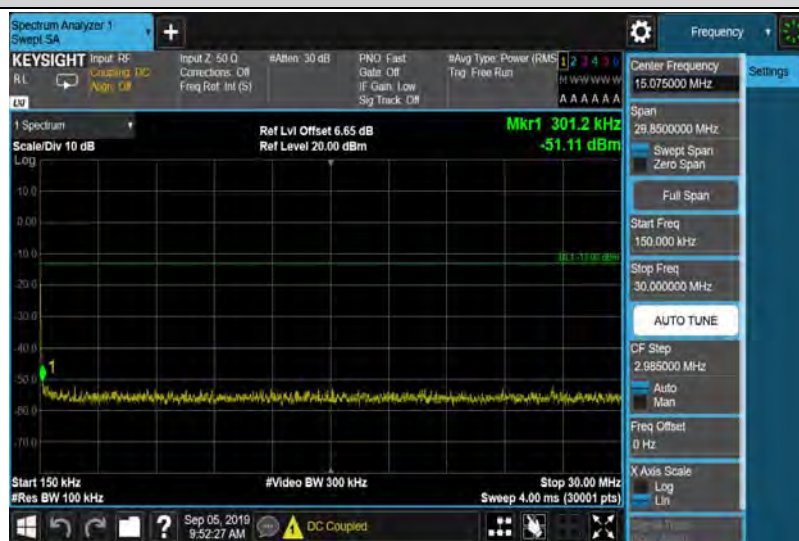

EGPRS850-190-0.15~30



EGPRS850-190-30~1000



EGPRS850-190-1000~5000



EGPRS850-190-5000~12000



EGPRS850-190-12000~18000



EGPRS850-251-0.009~0.15

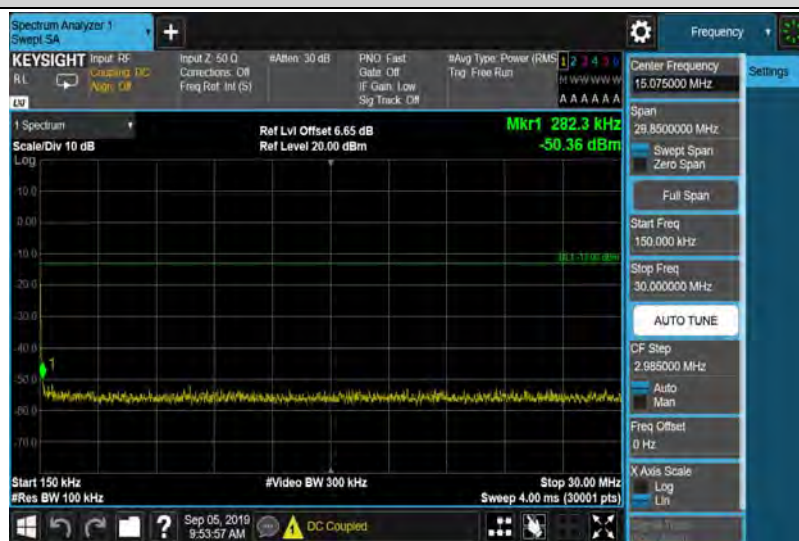

EGPRS850-251-0.15~30



EGPRS850-251-30~1000



EGPRS850-251-1000~5000



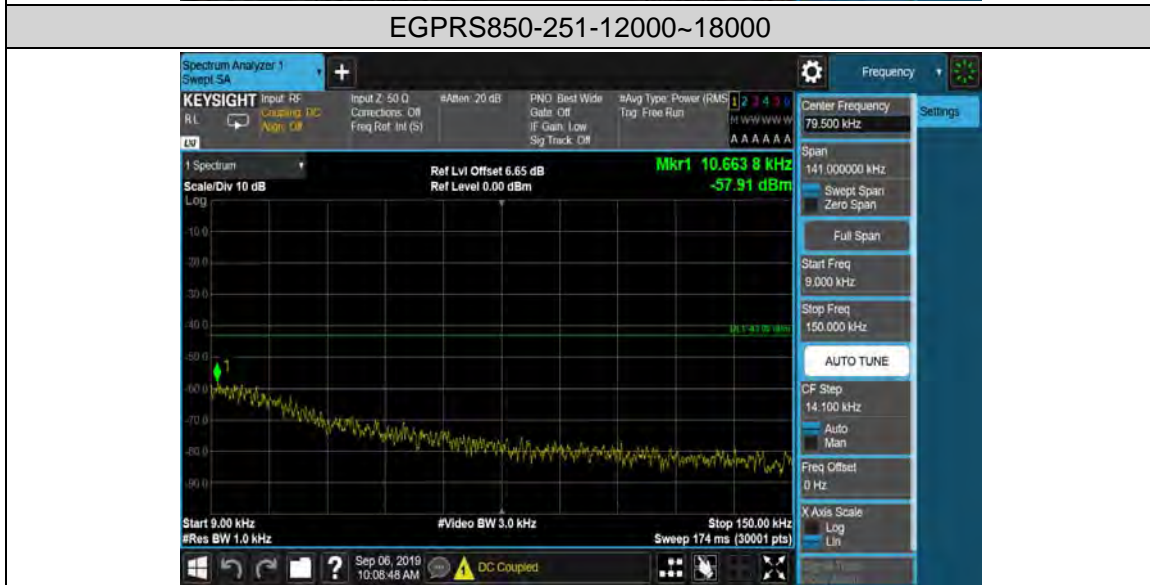



WCDMA Band V_4132



WCDMA Band V_4132



WCDMA Band V_4132



WCDMA Band V_4132



WCDMA Band V_4132



WCDMA Band V_4132



WCDMA Band V_4182



WCDMA Band V_4182





WCDMA Band V_4182



WCDMA Band V_4233



WCDMA Band V_4233





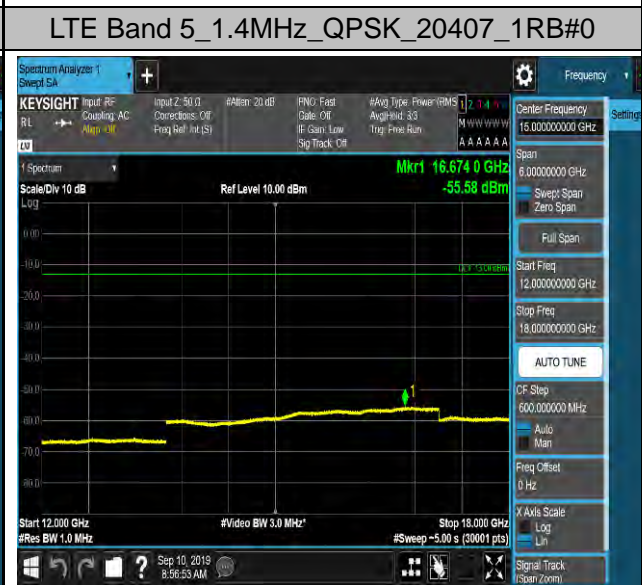
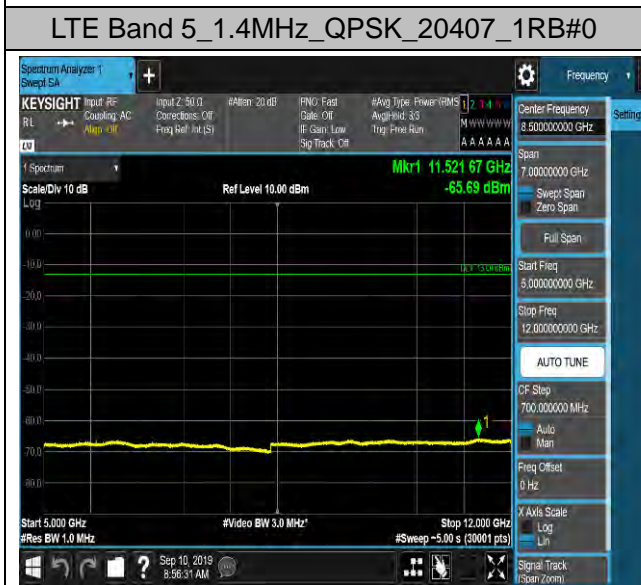
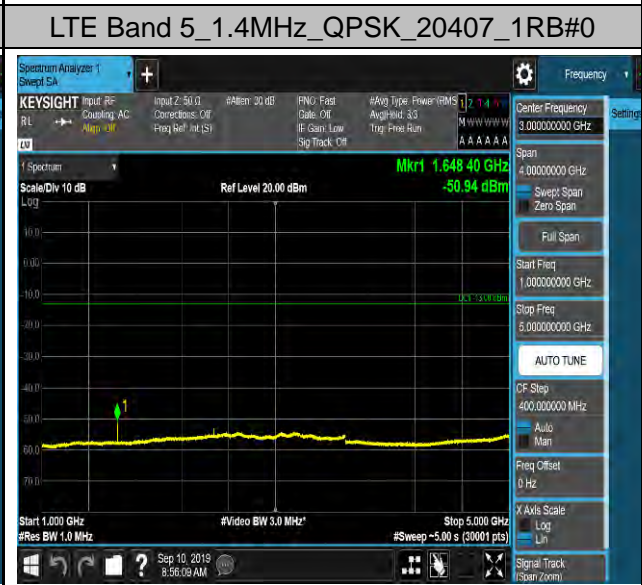
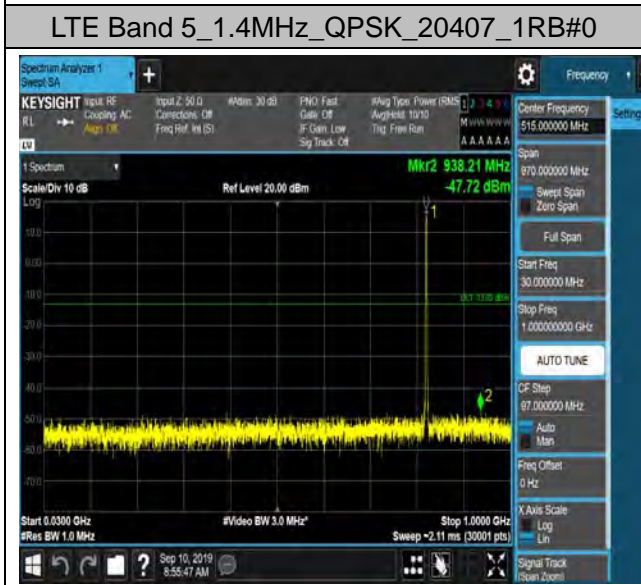
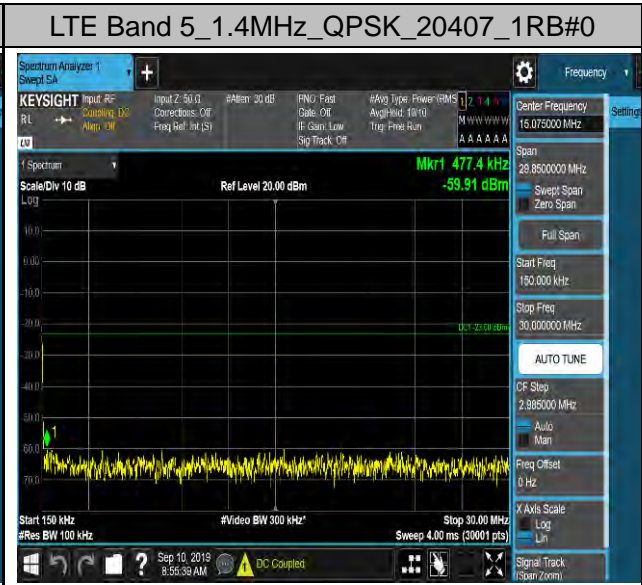
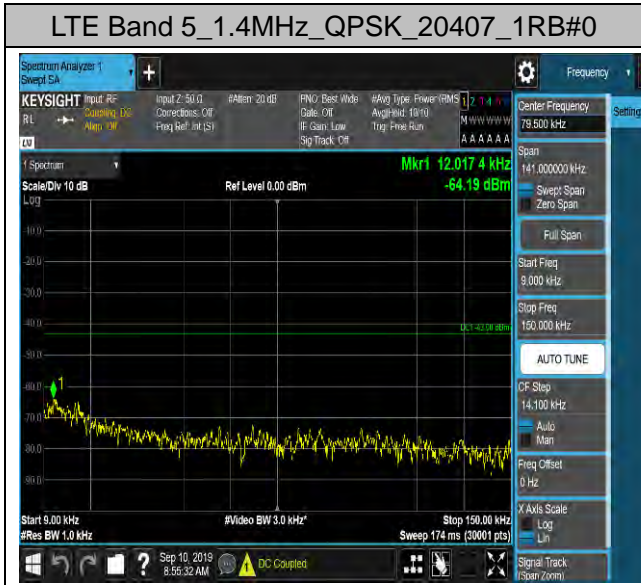

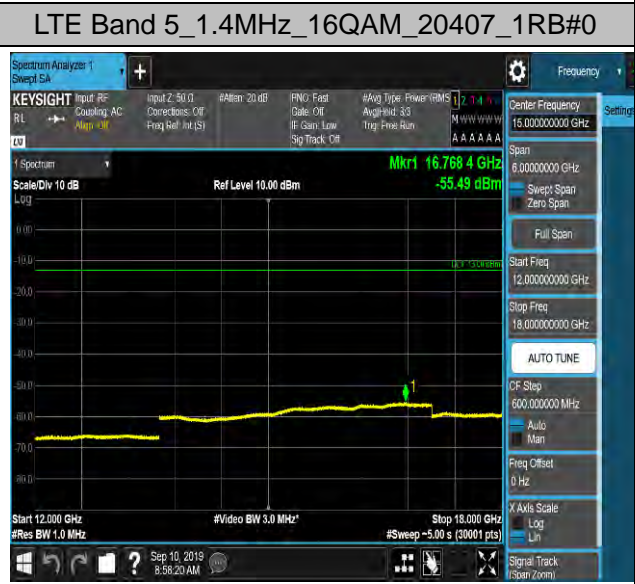
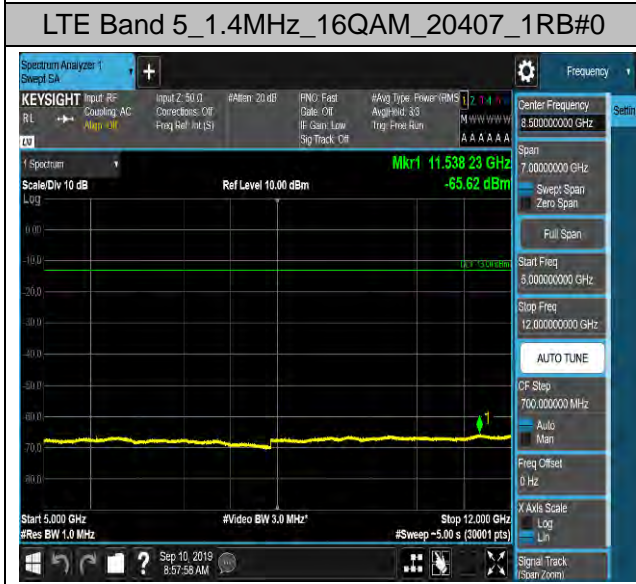
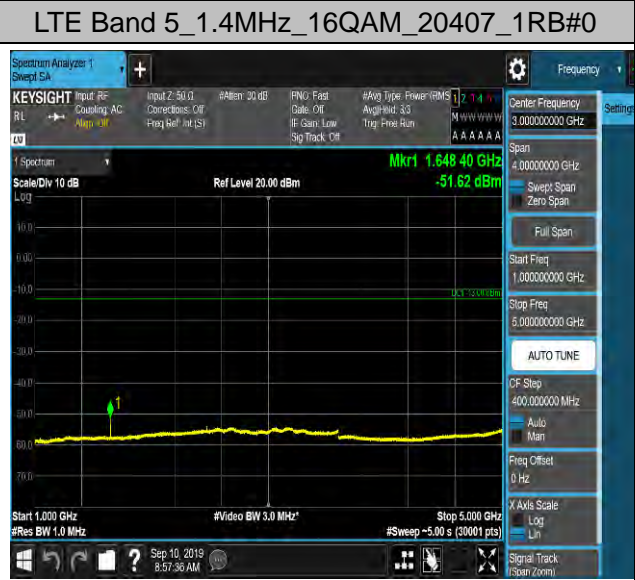
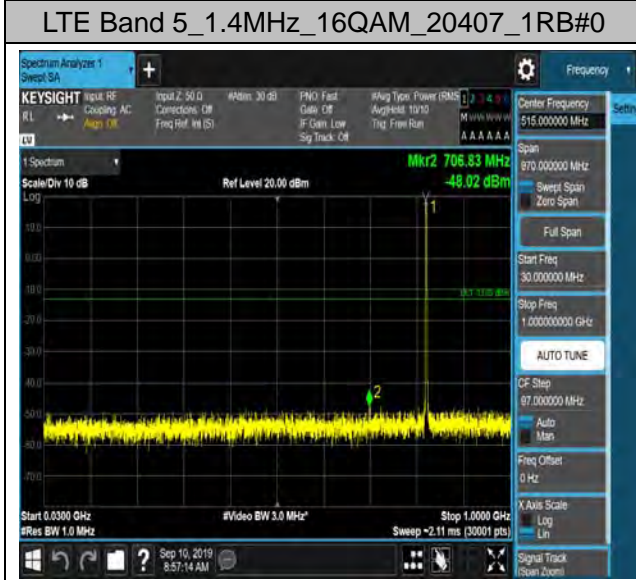
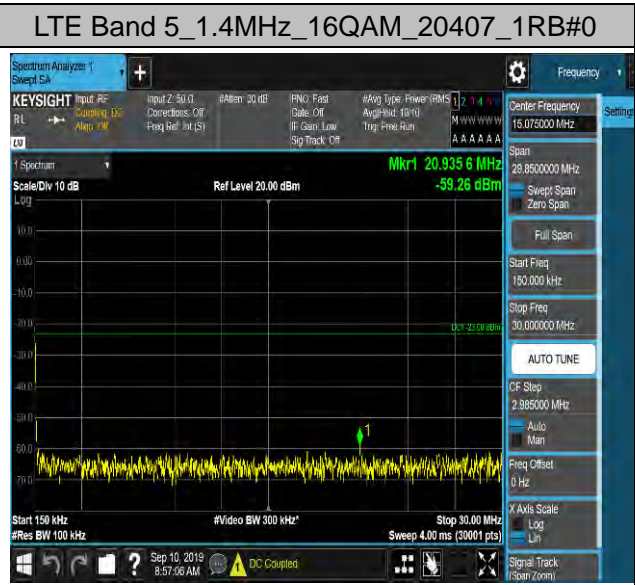
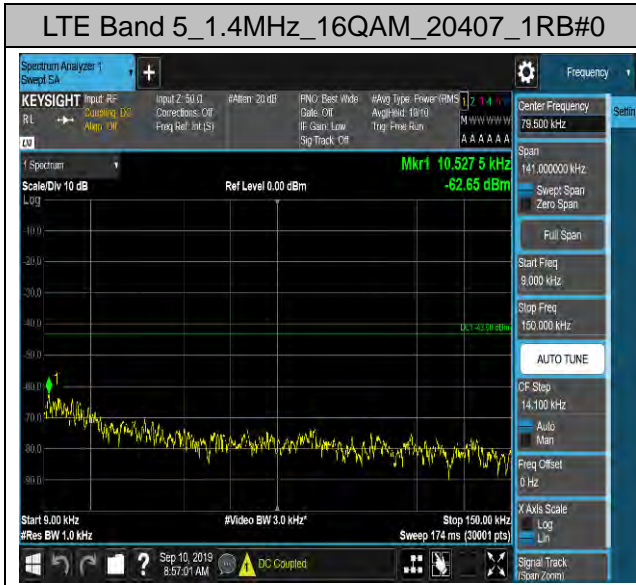

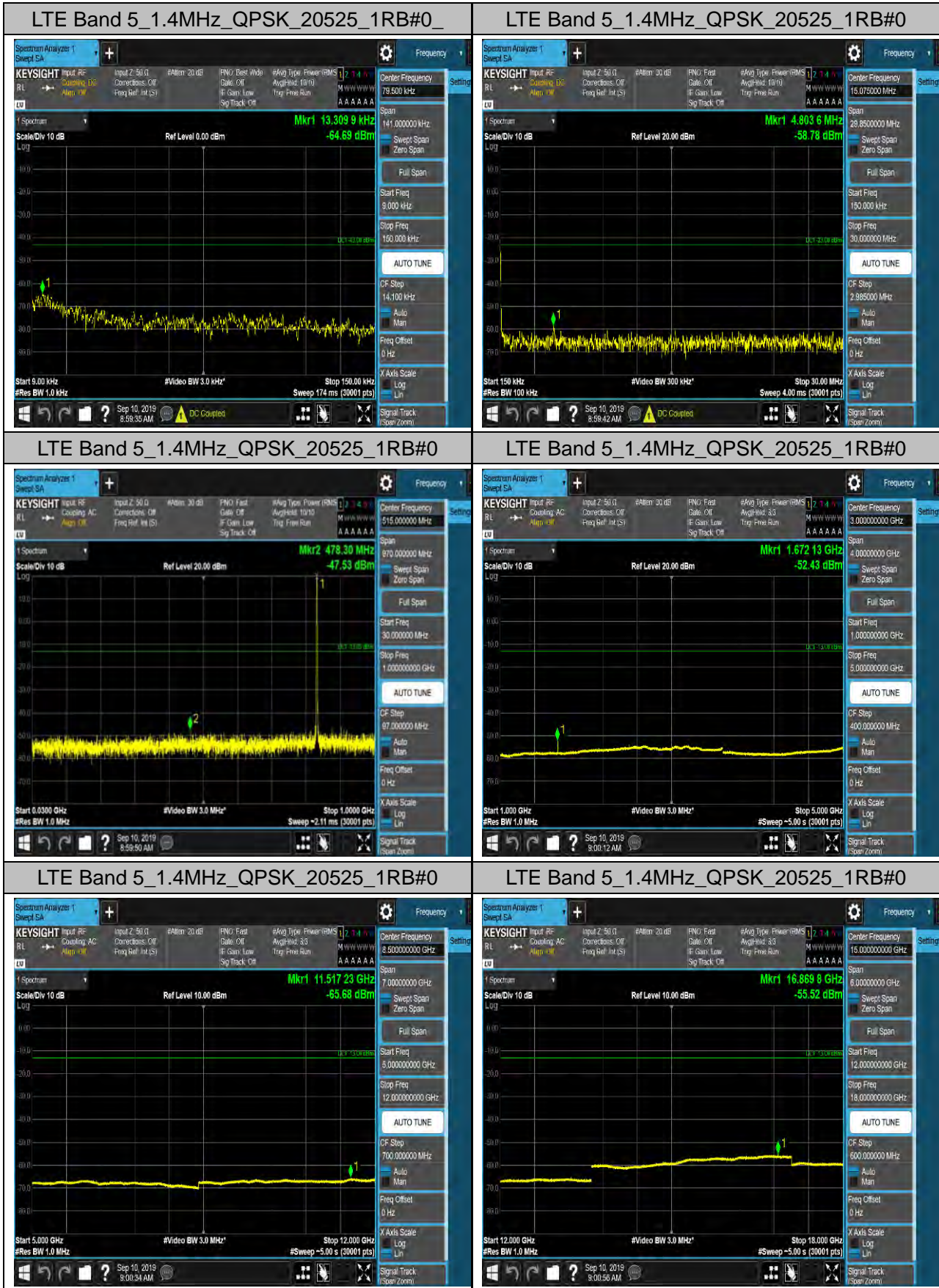

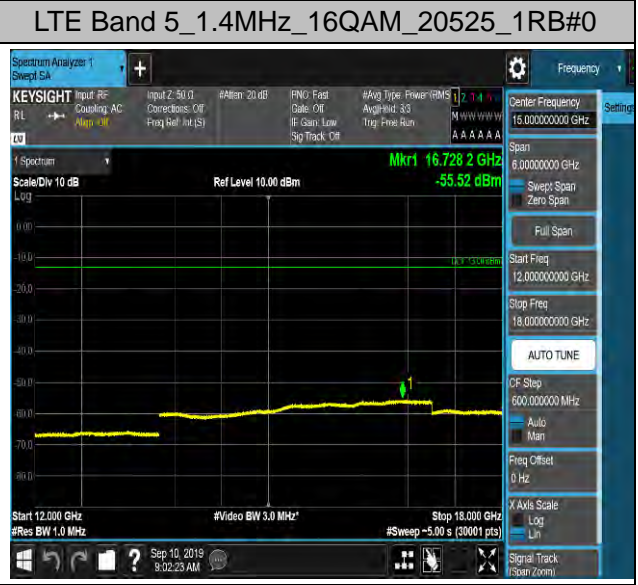
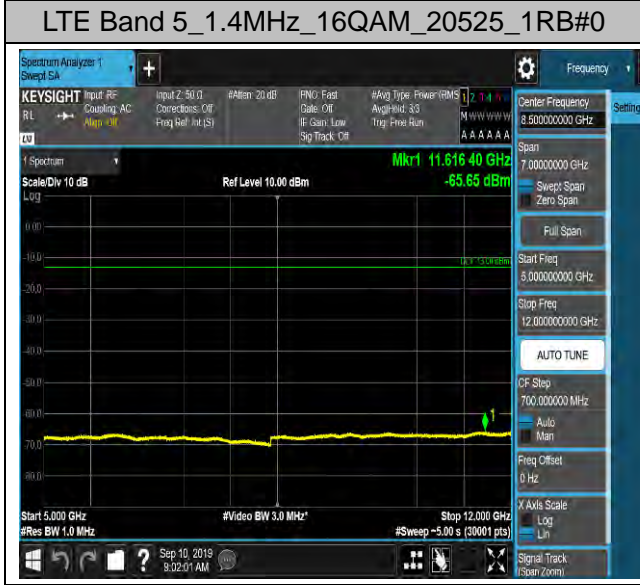
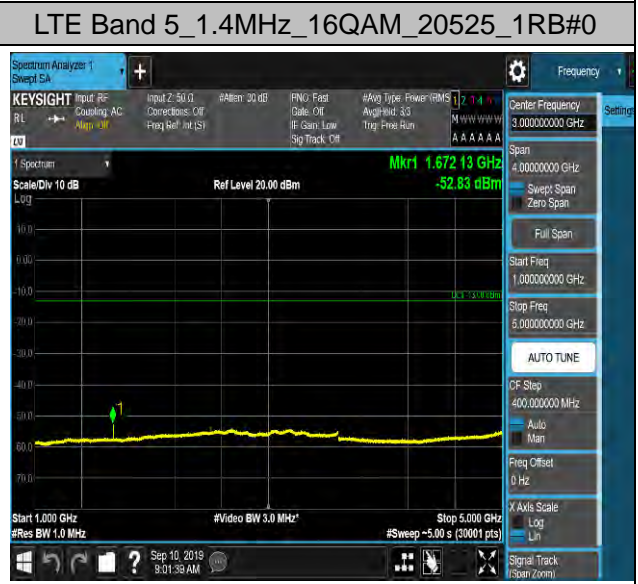
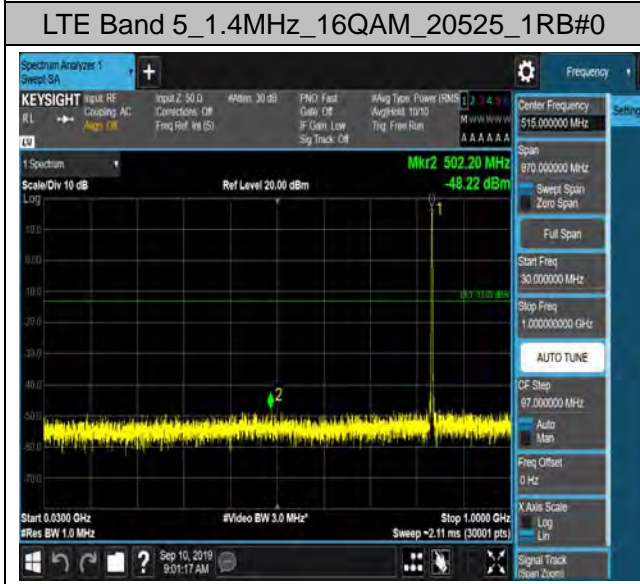
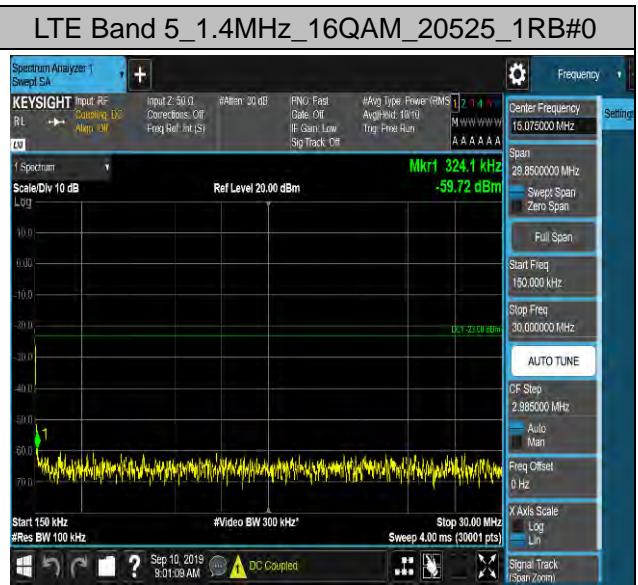
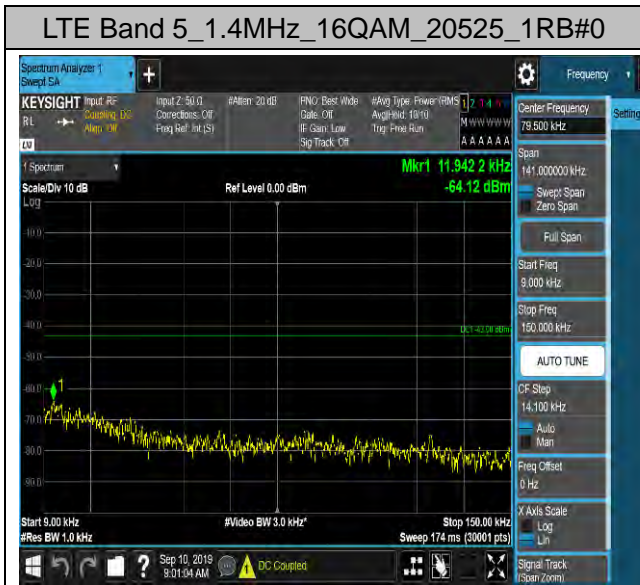

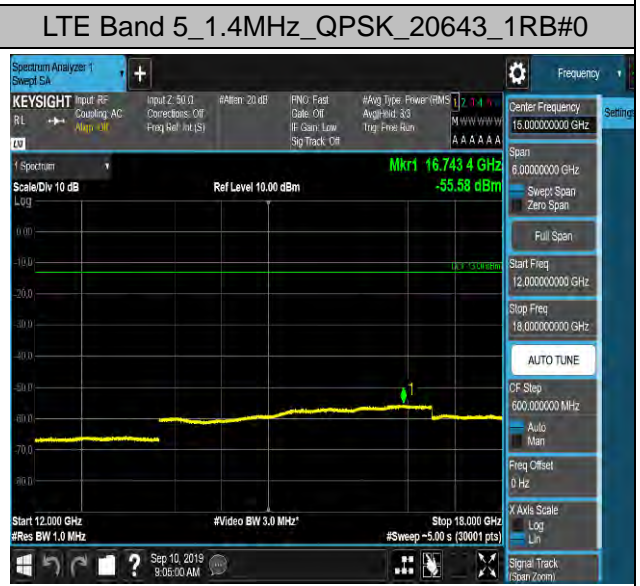
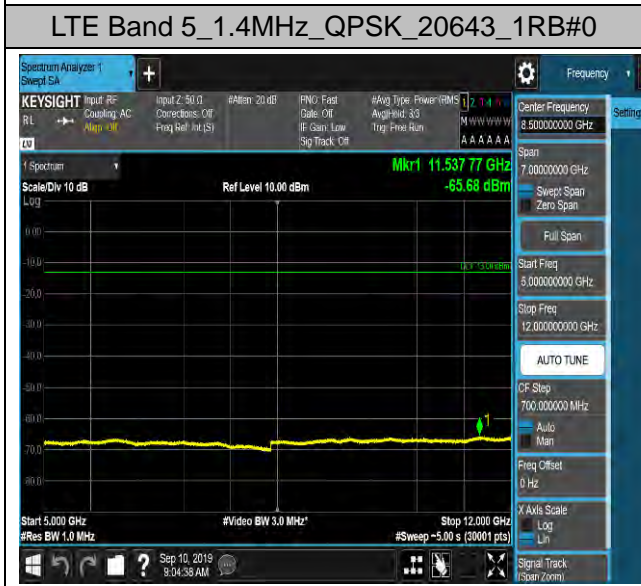
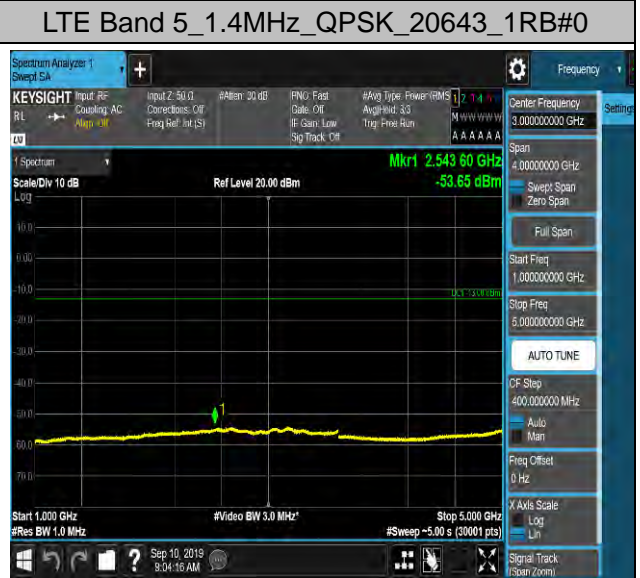
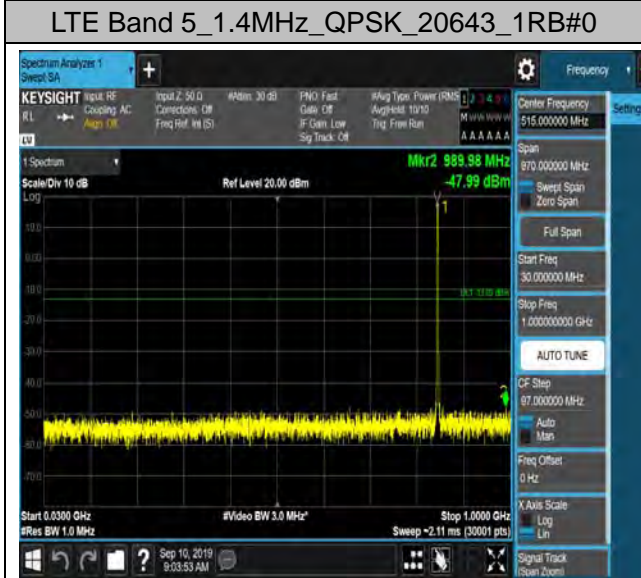
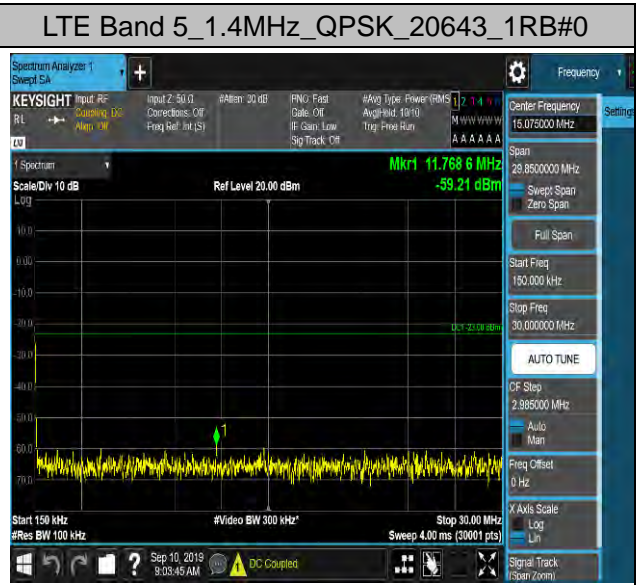
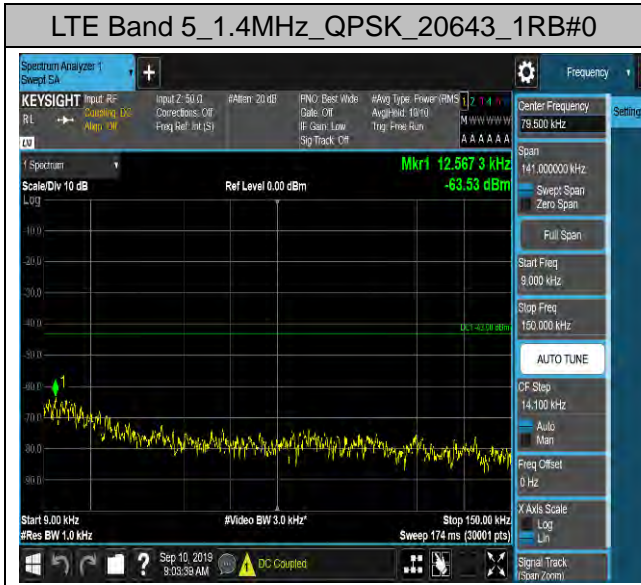

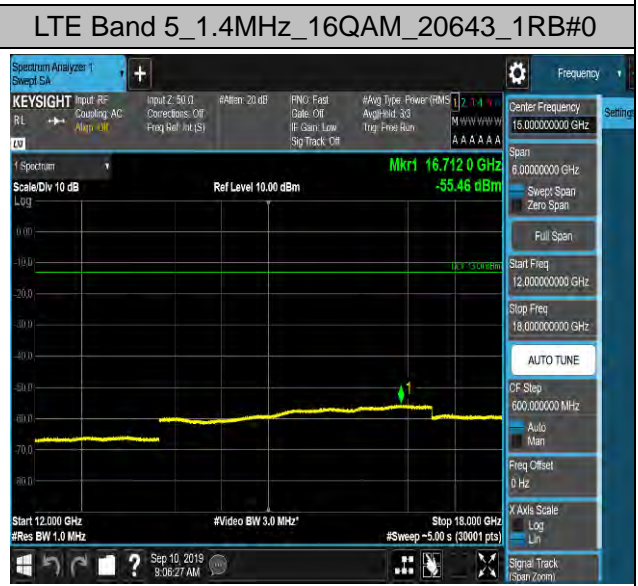
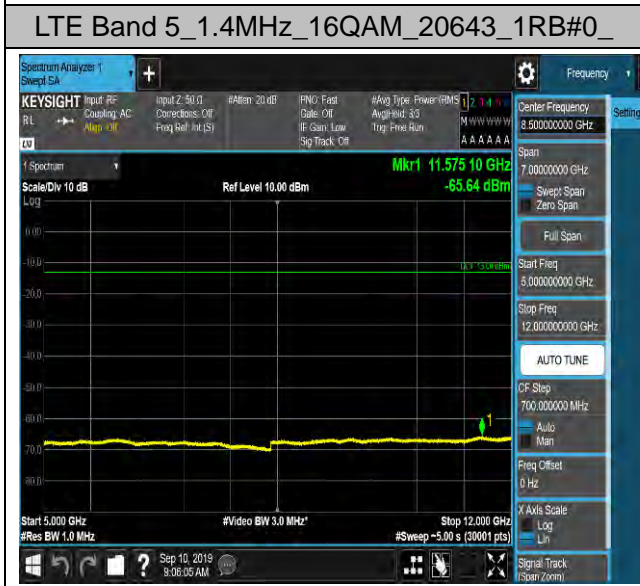
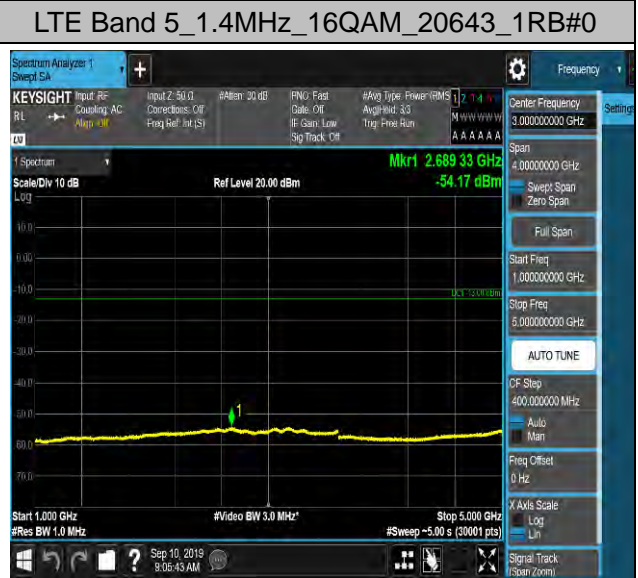
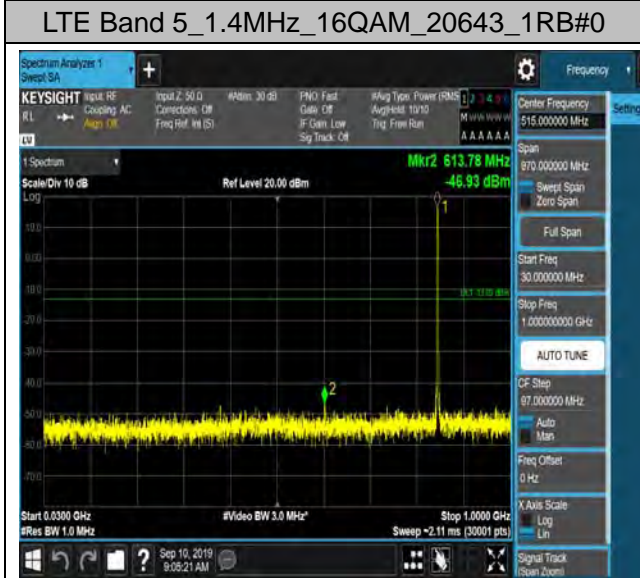
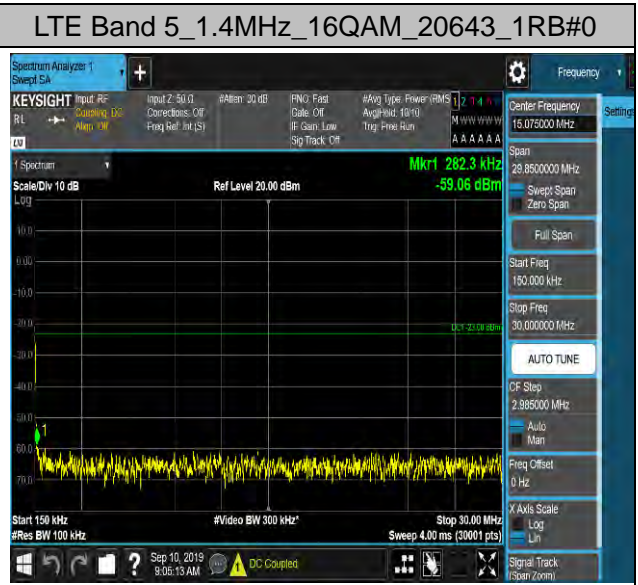
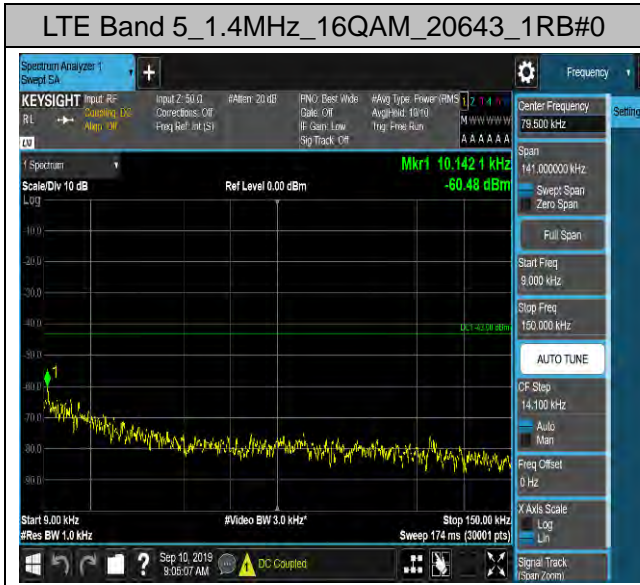

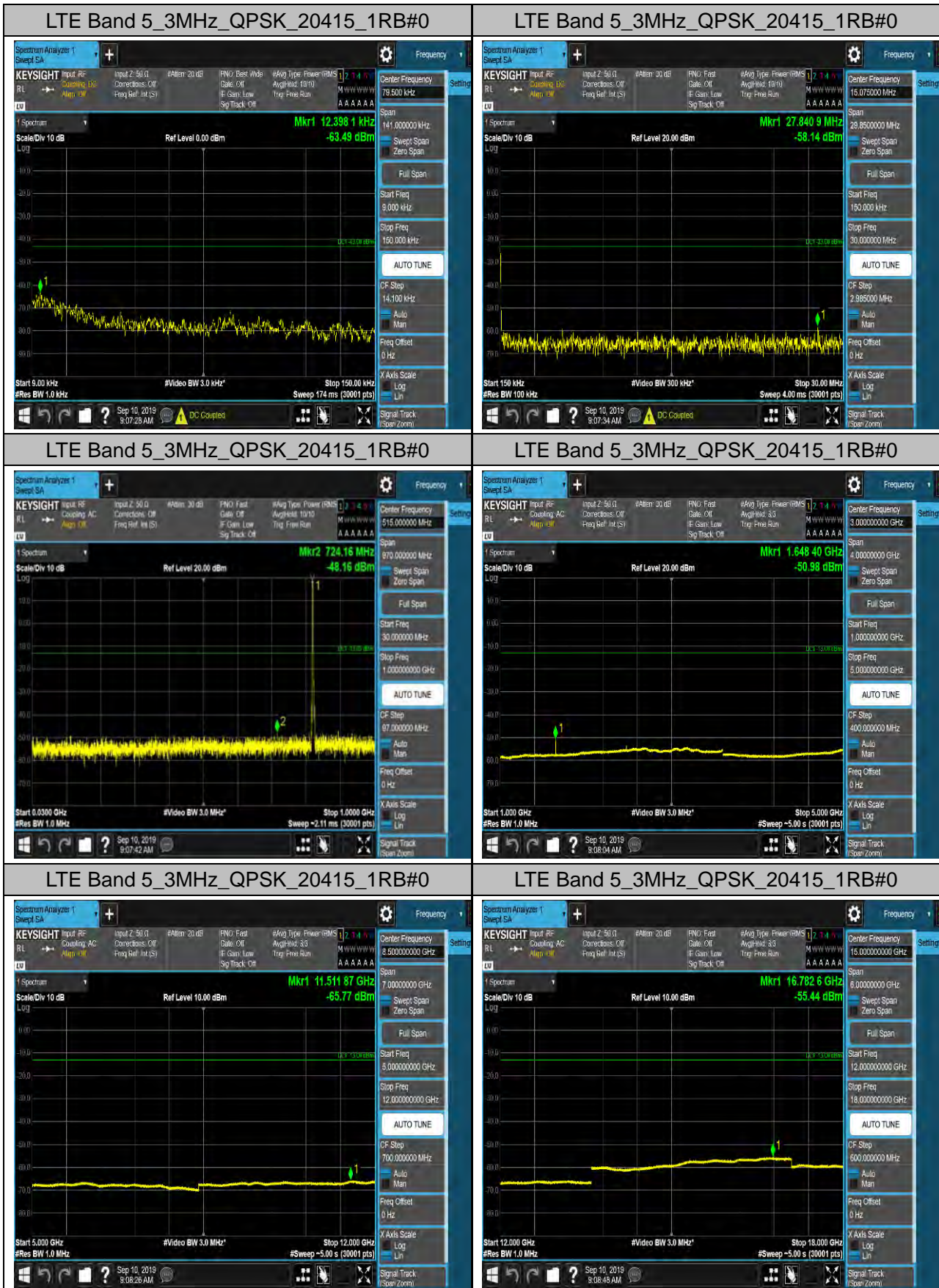

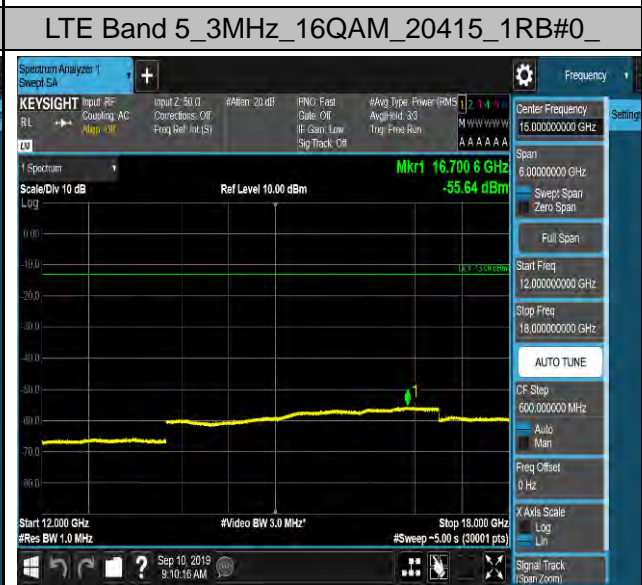
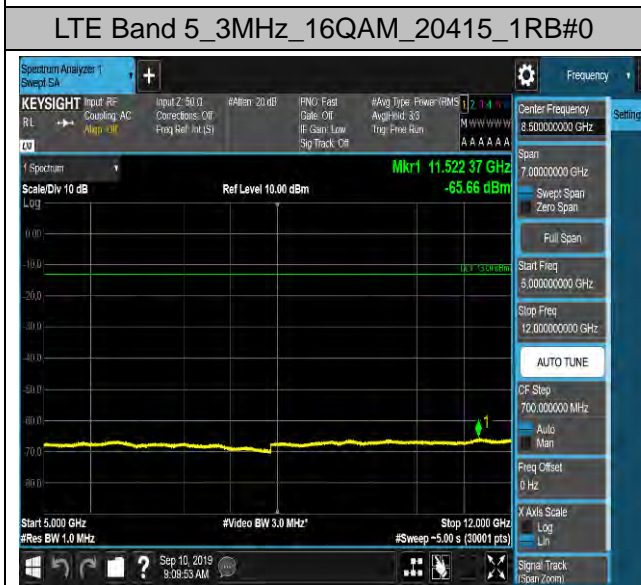
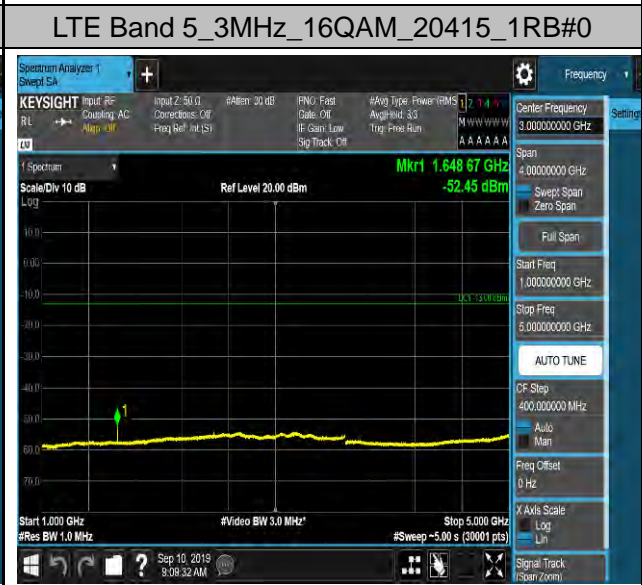
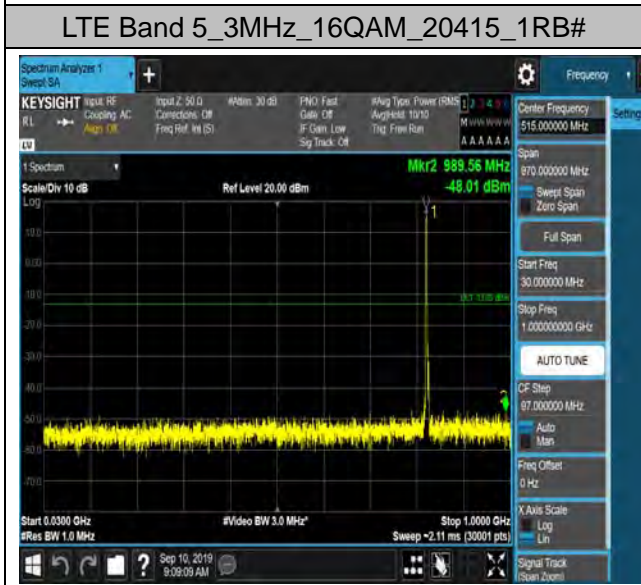
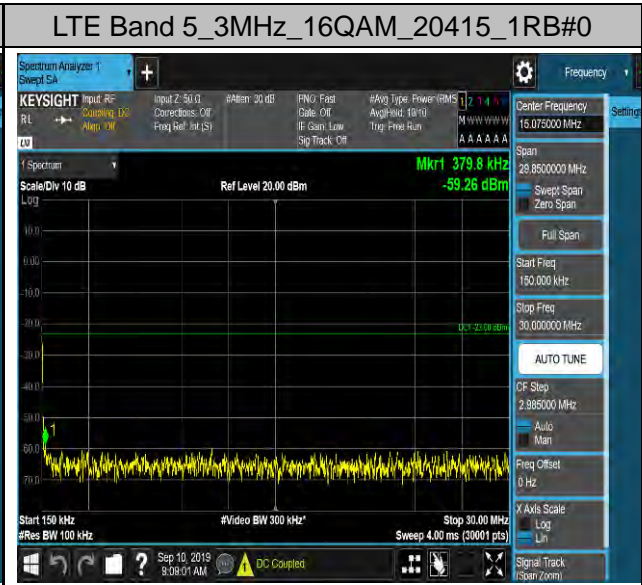
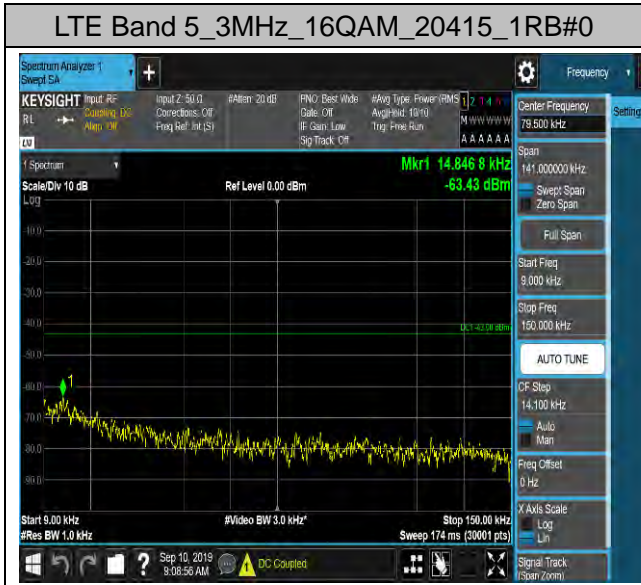

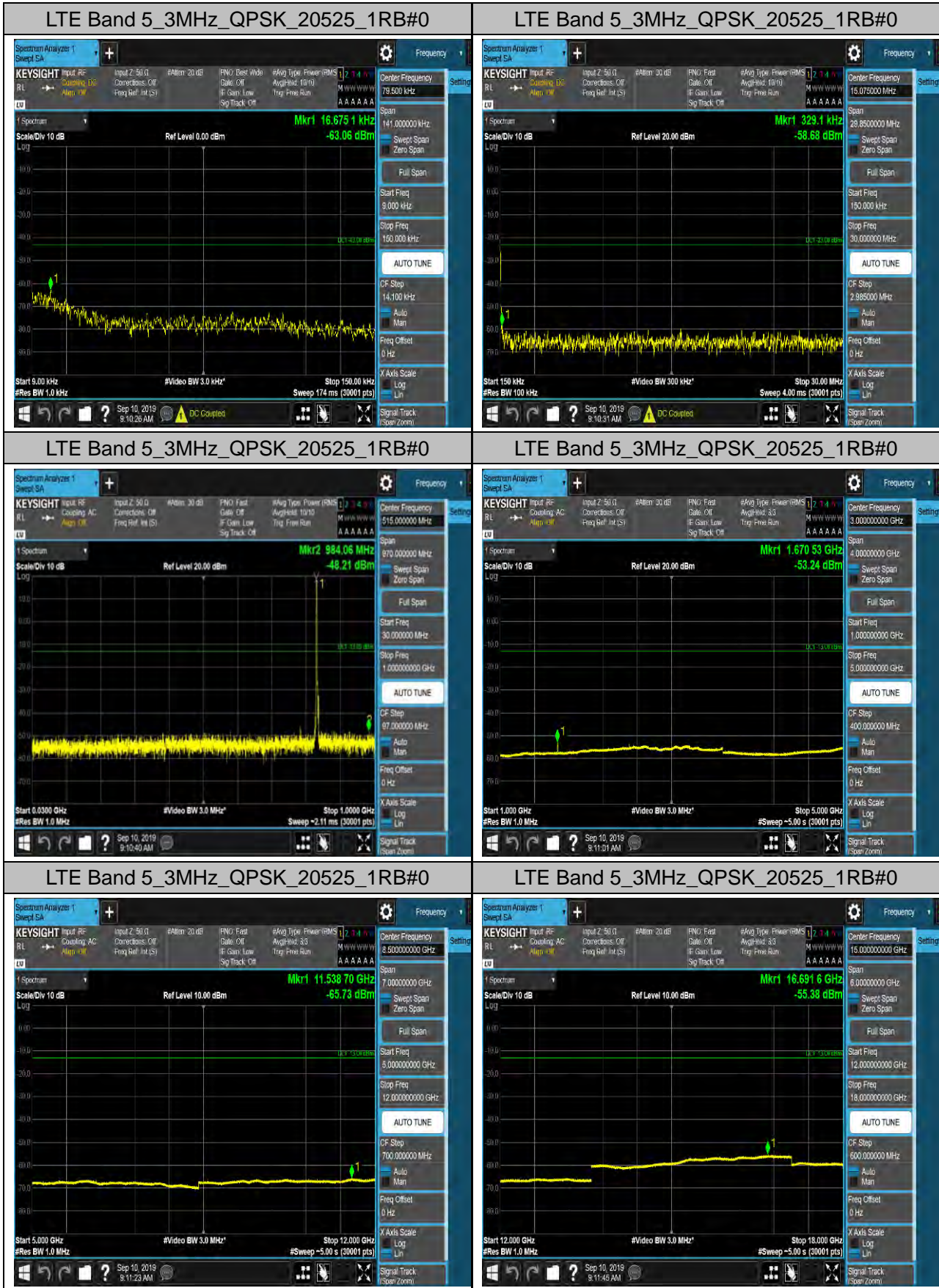



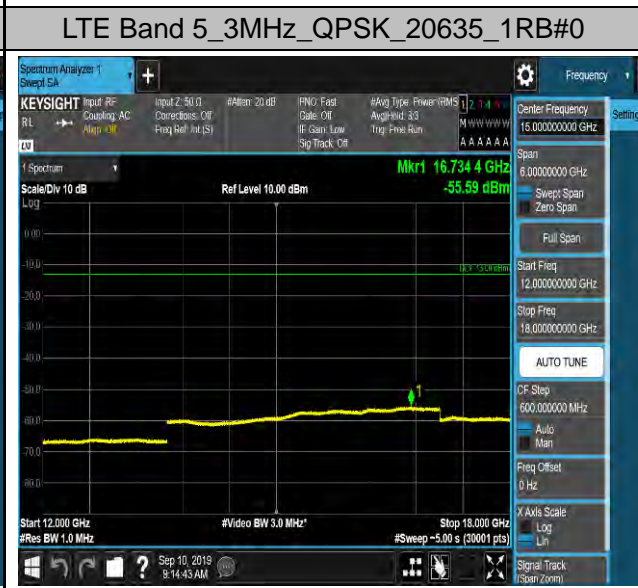
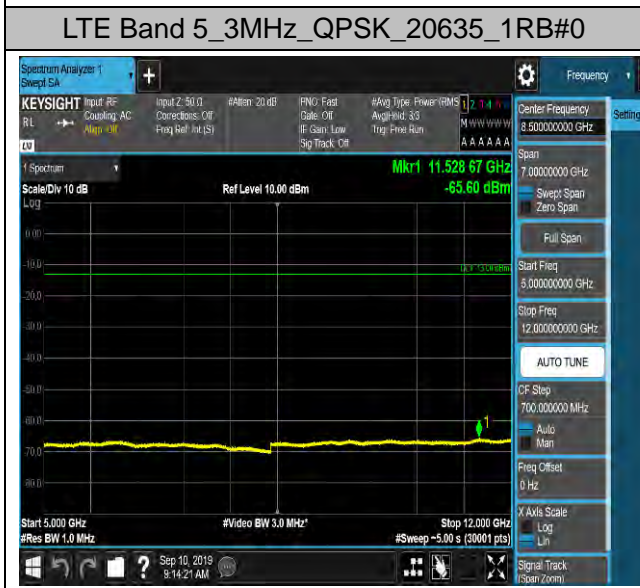
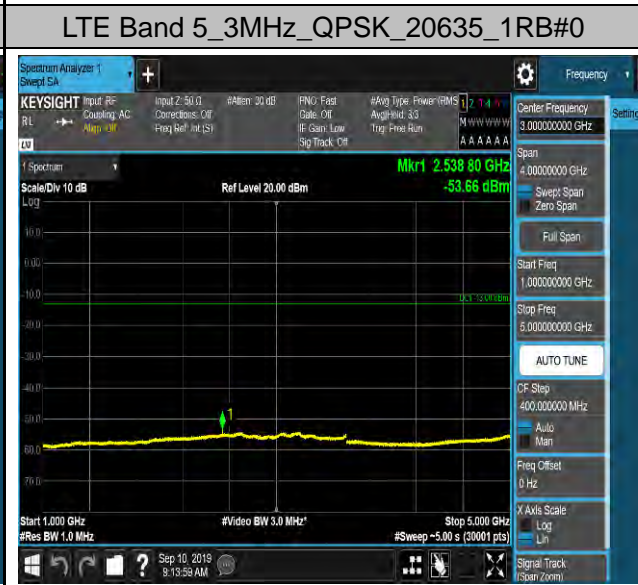
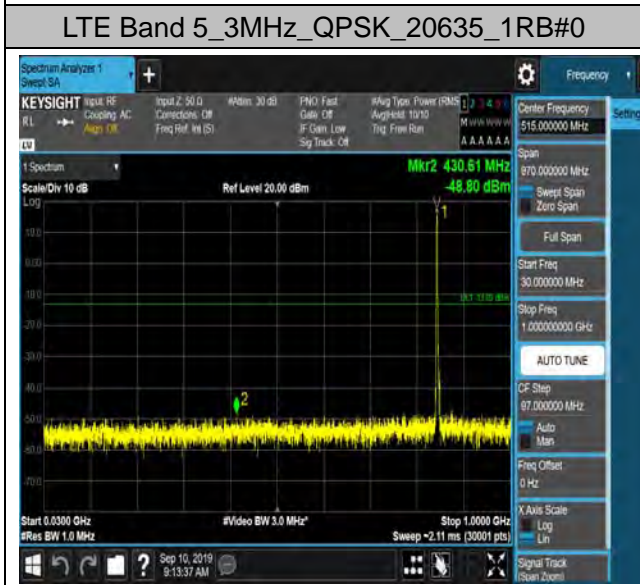
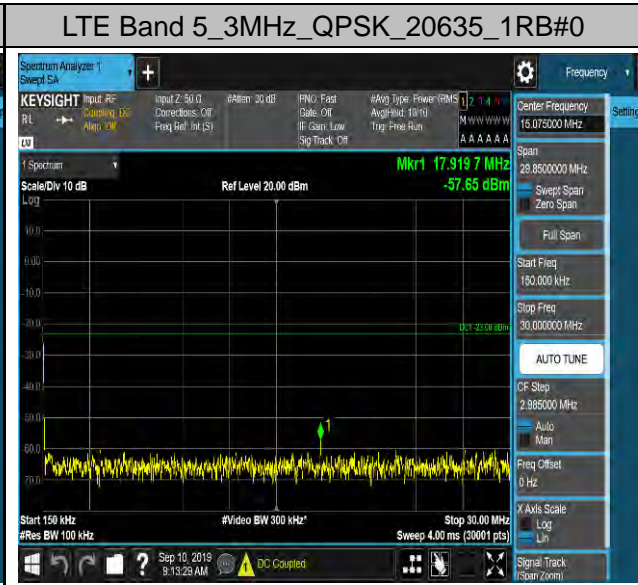
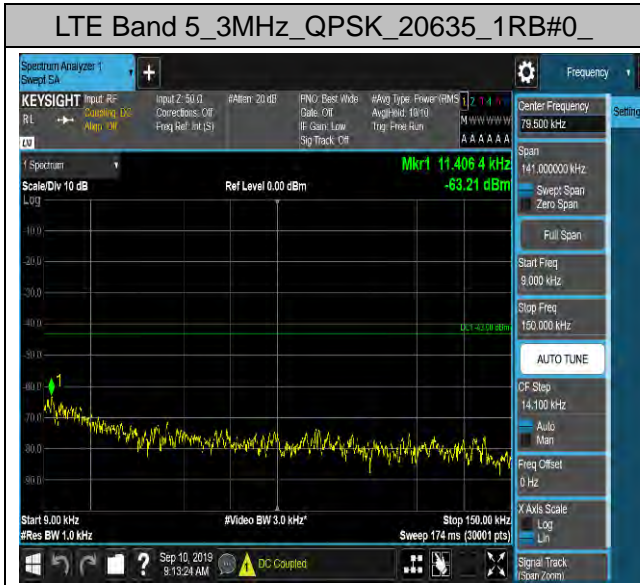

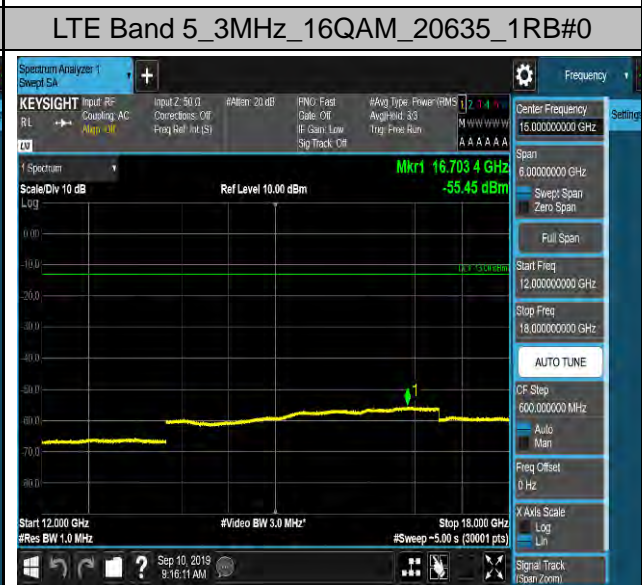
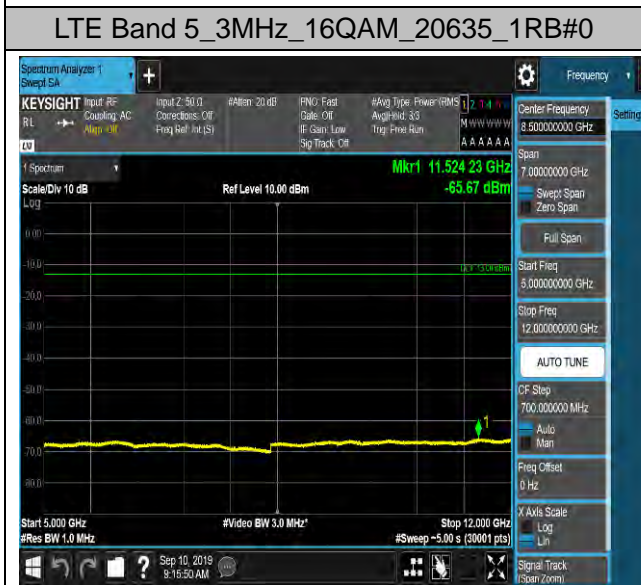
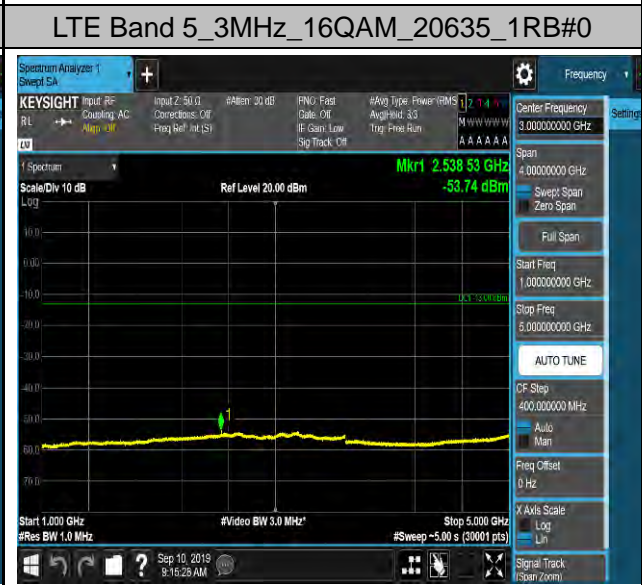
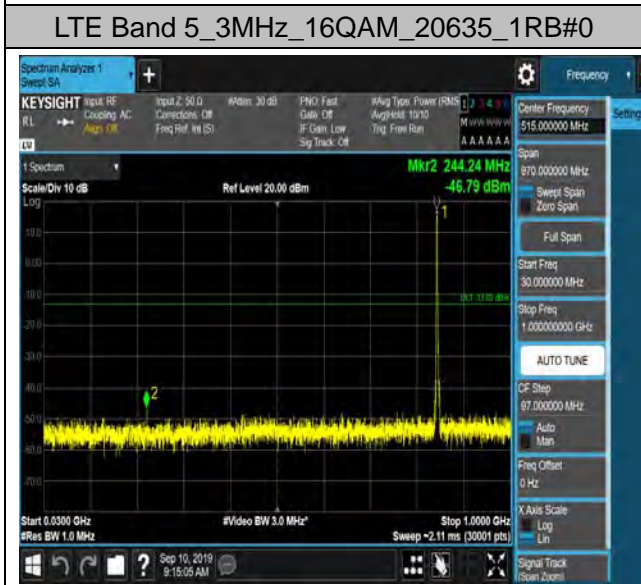
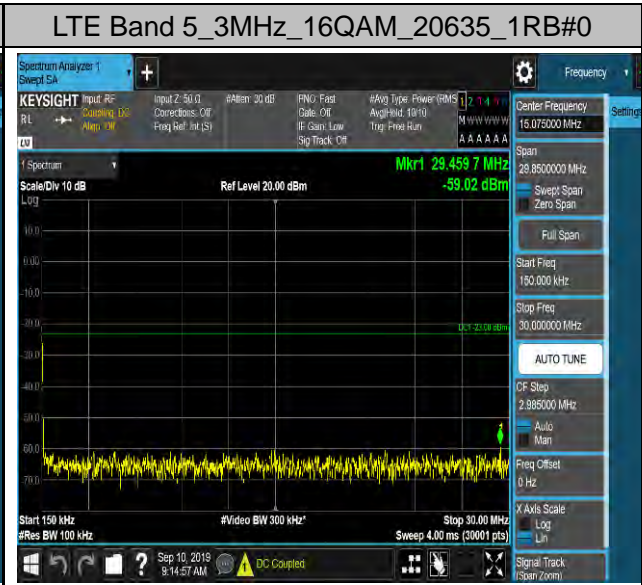
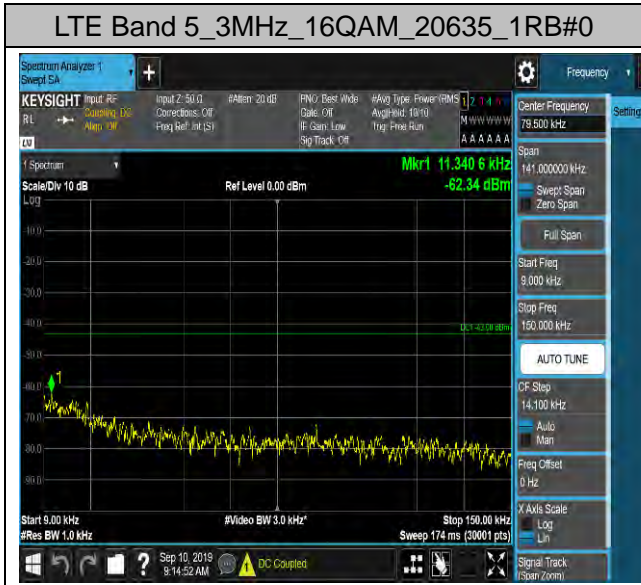

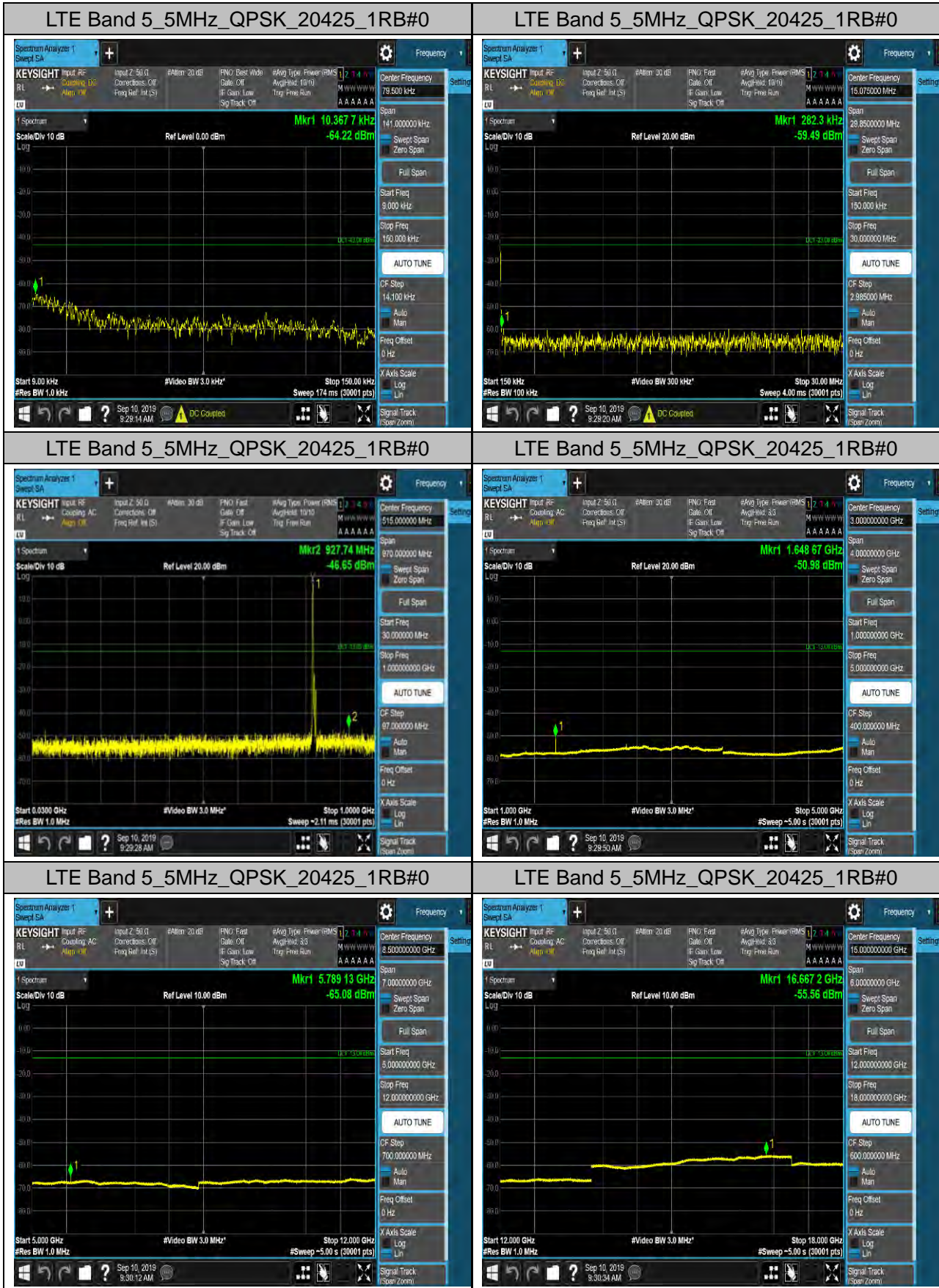

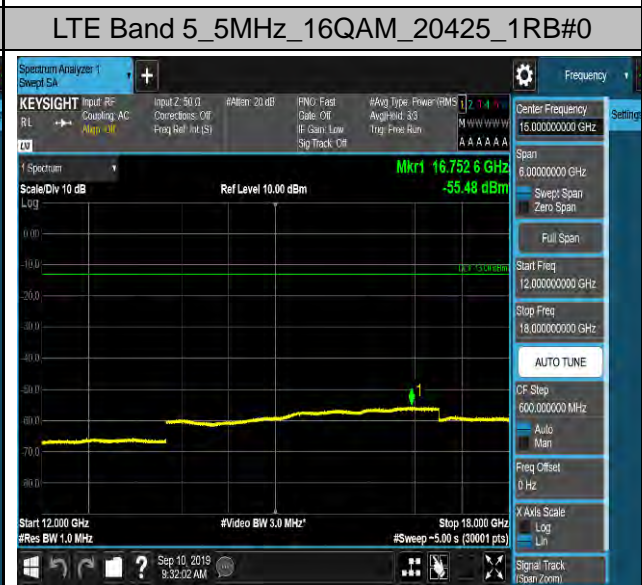
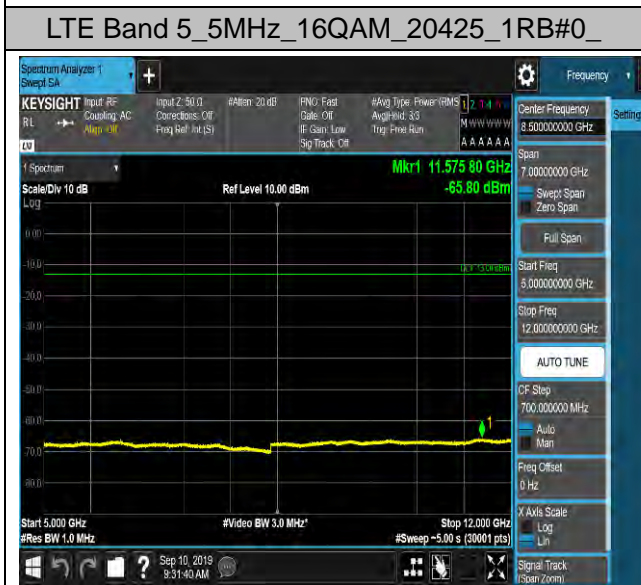
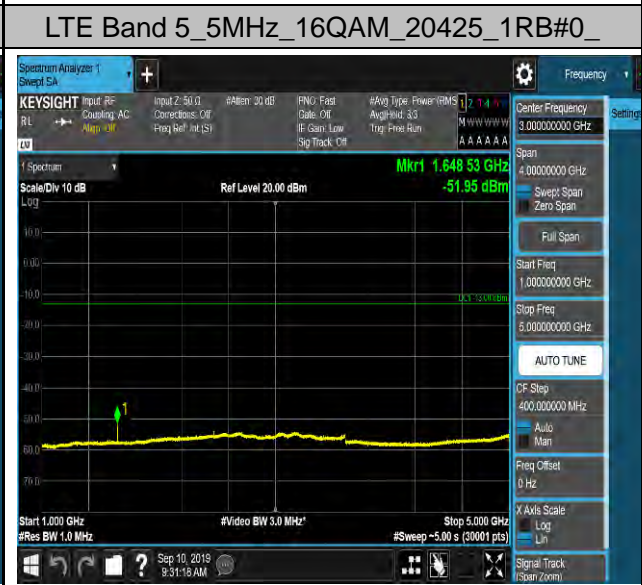
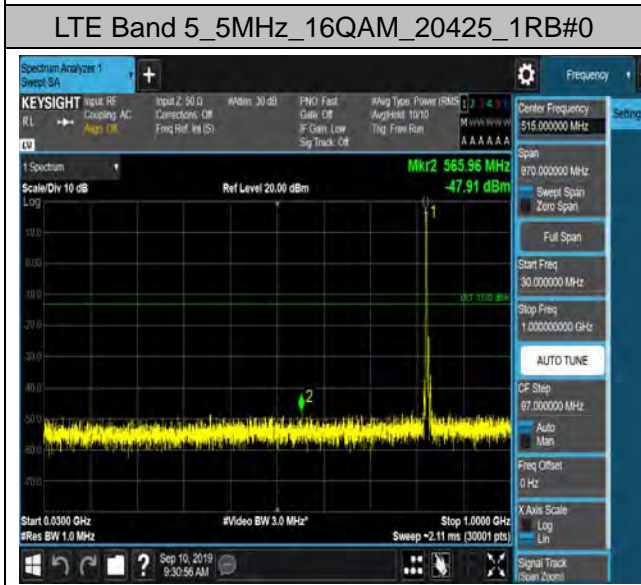
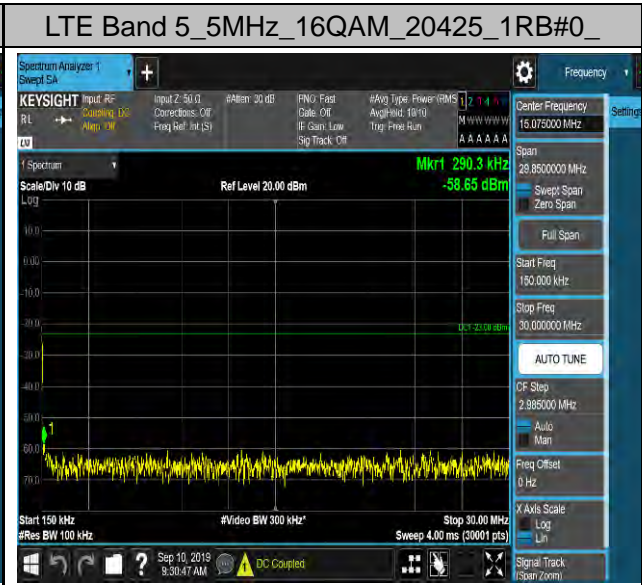
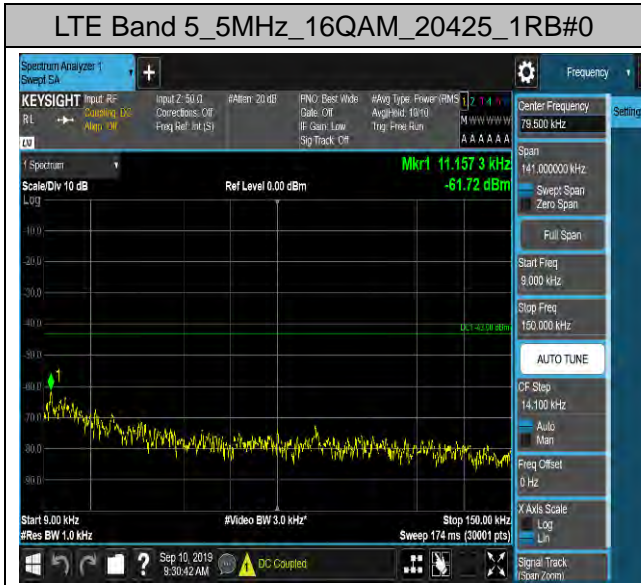

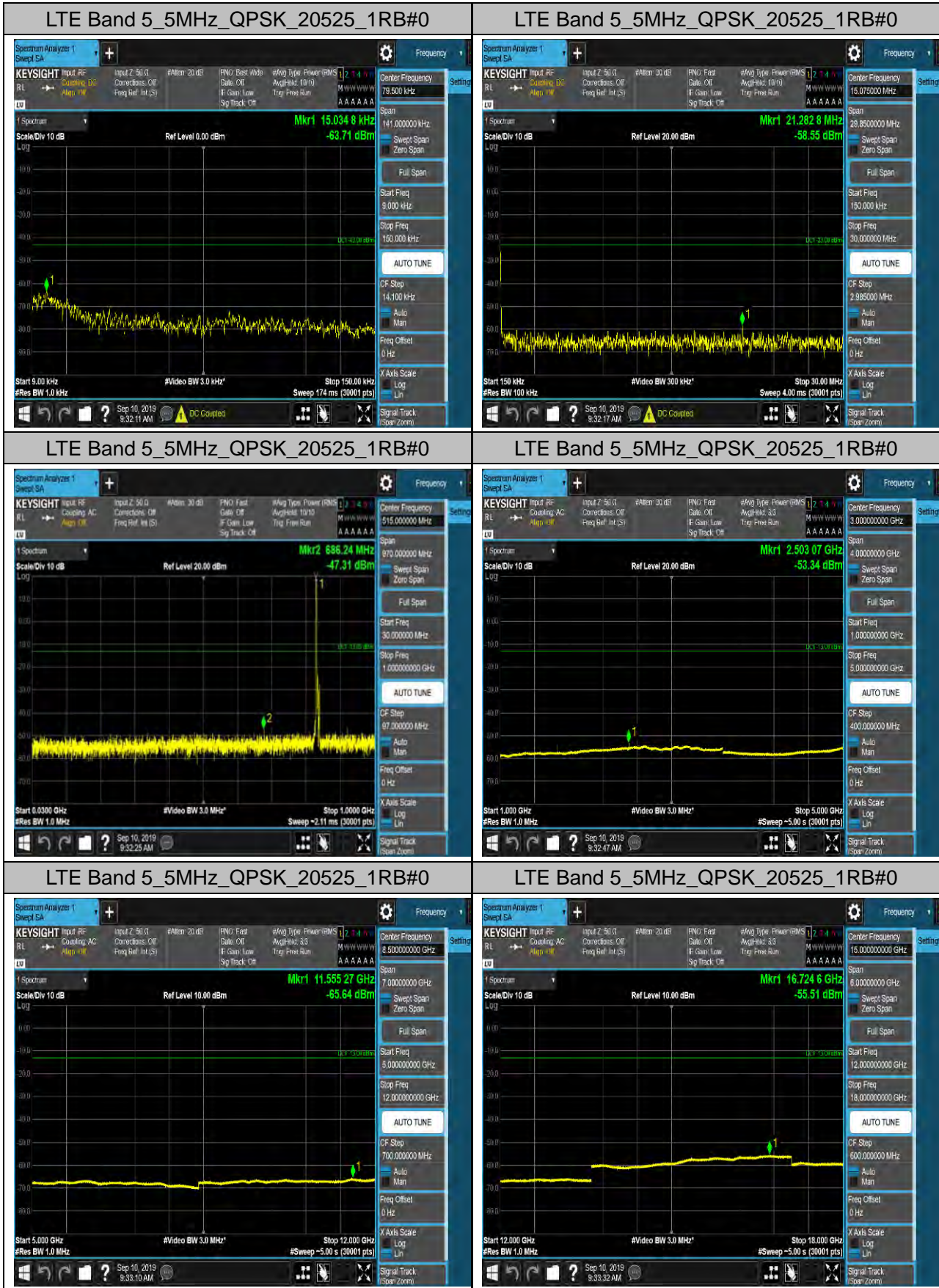

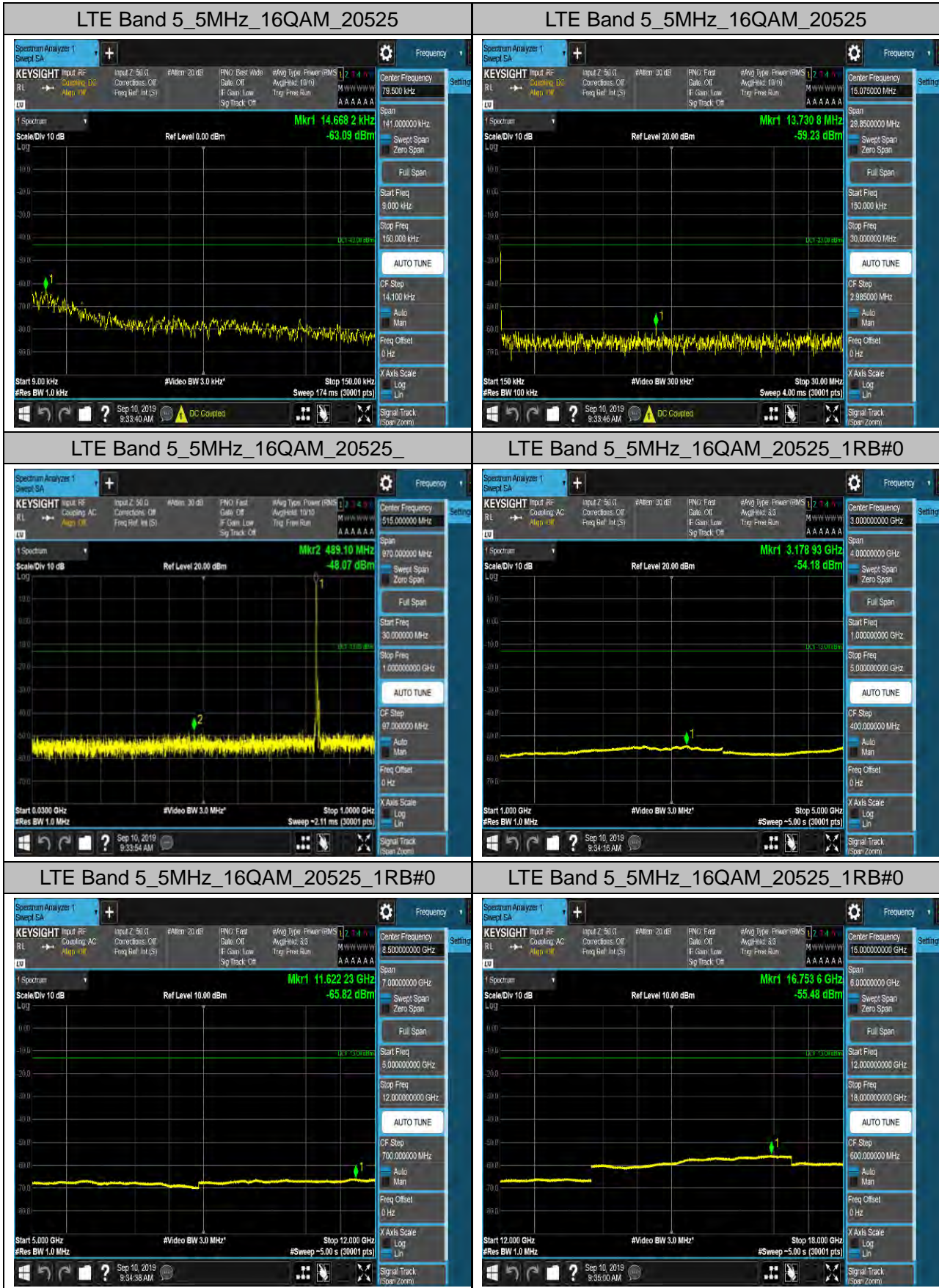

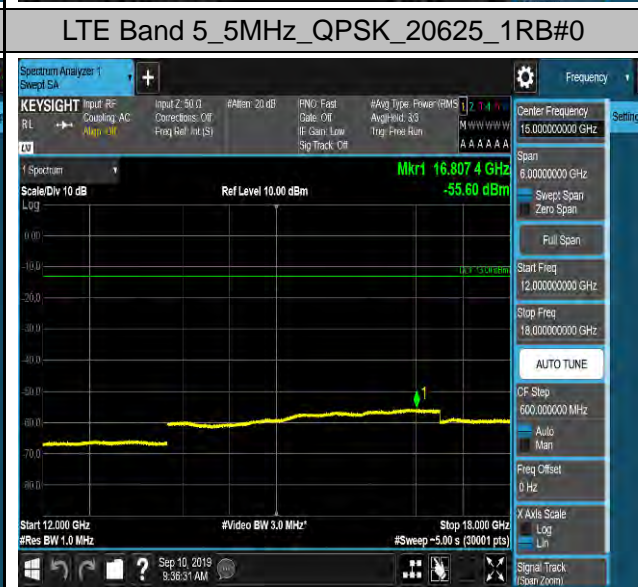
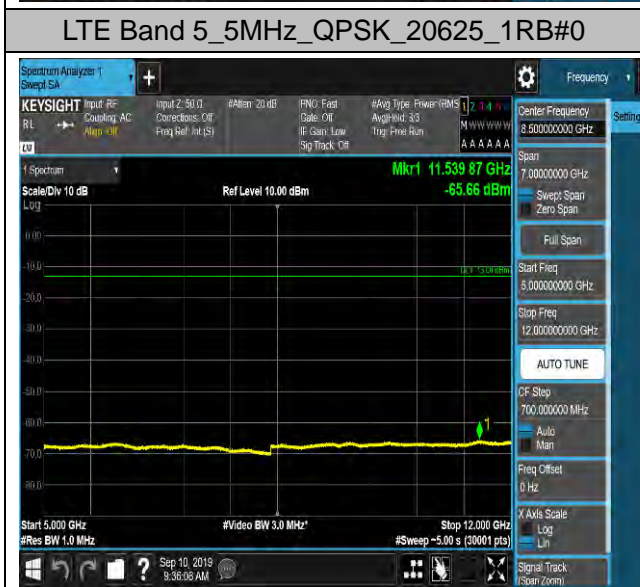
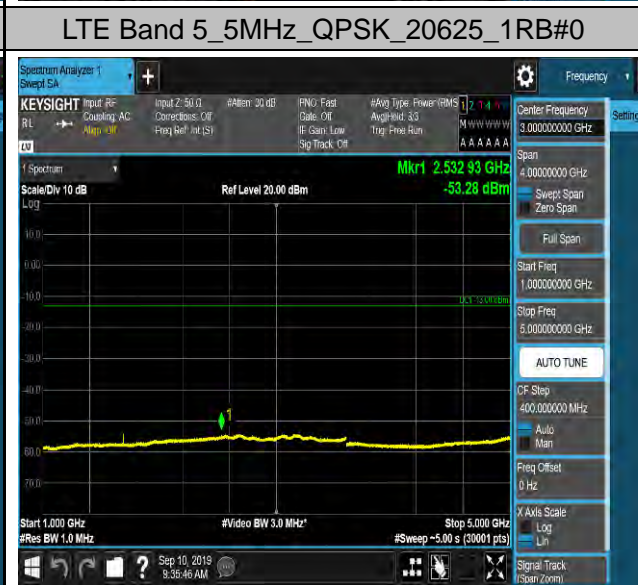
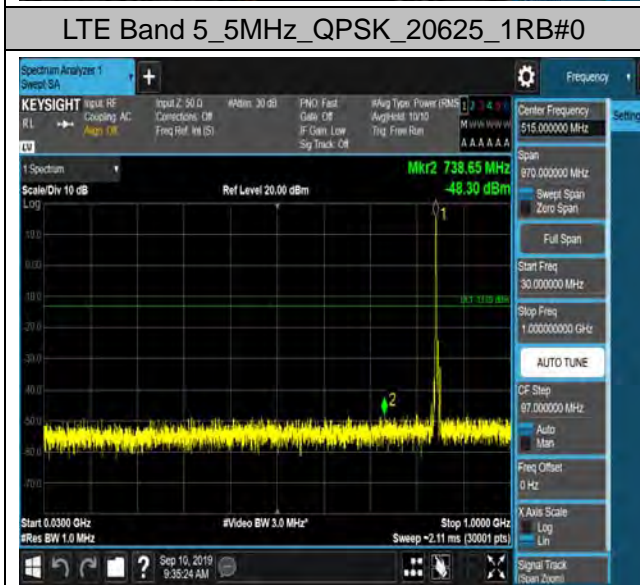
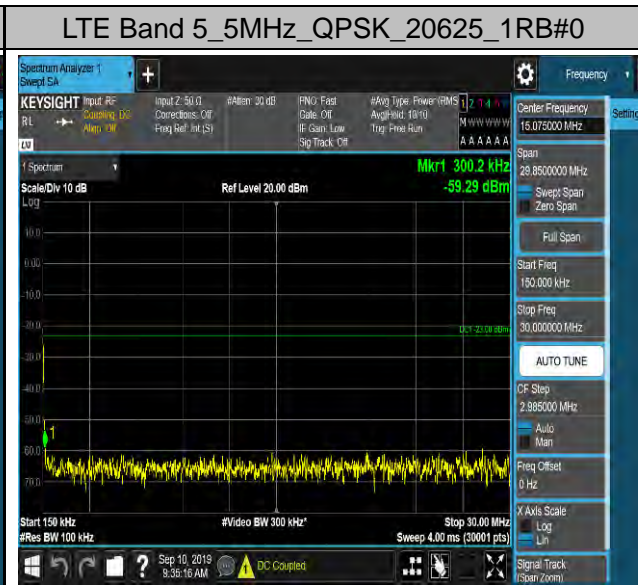
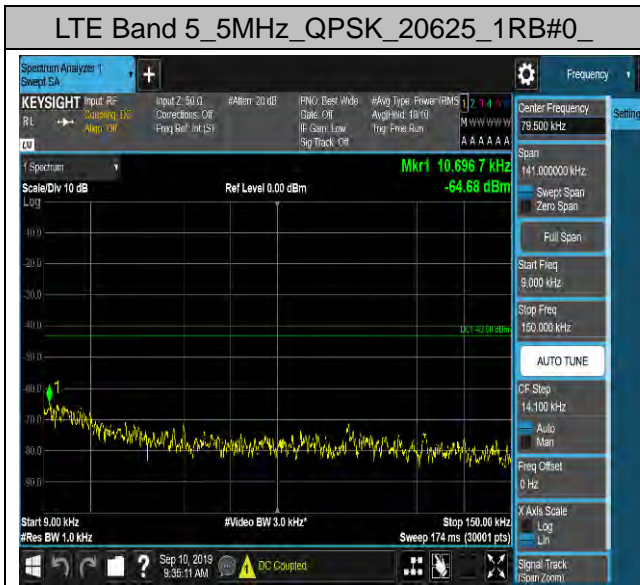

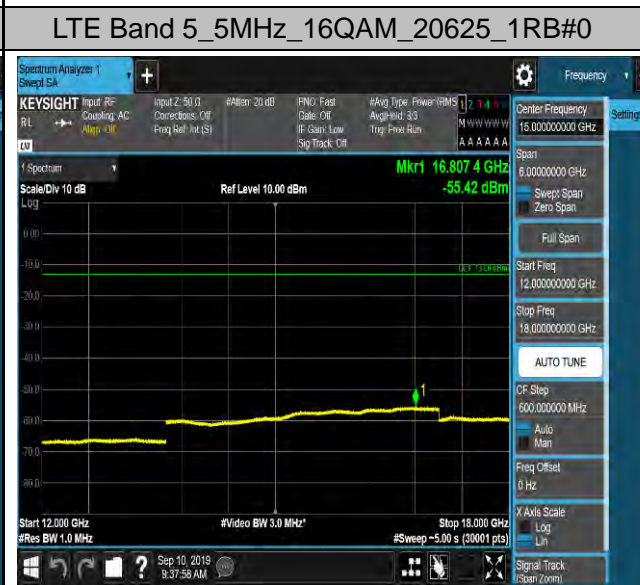
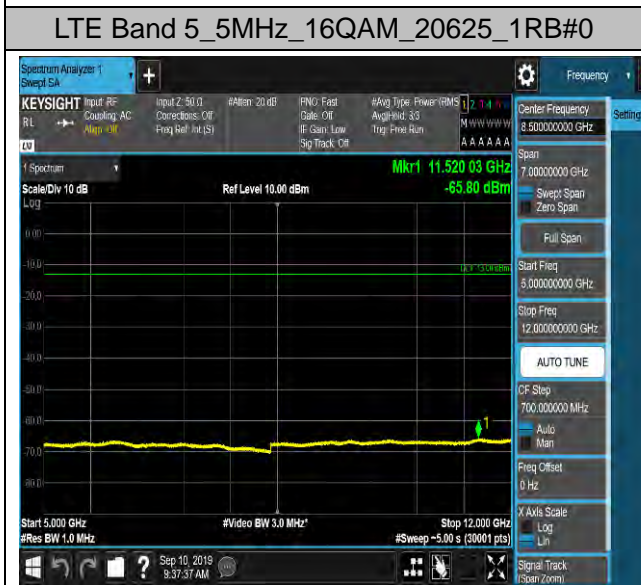
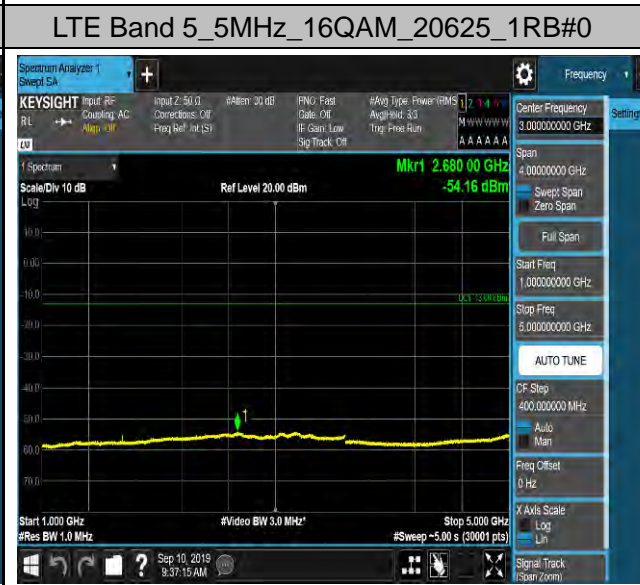
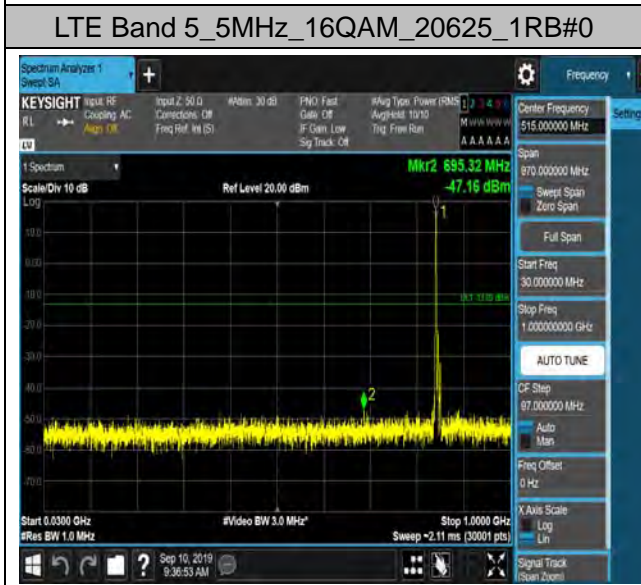
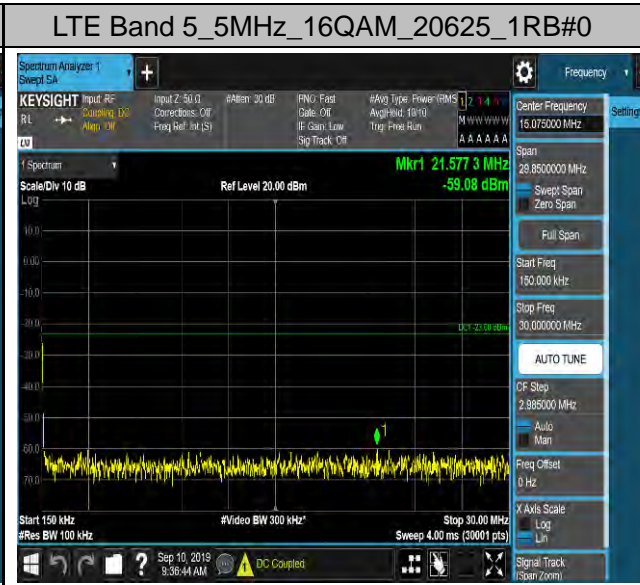
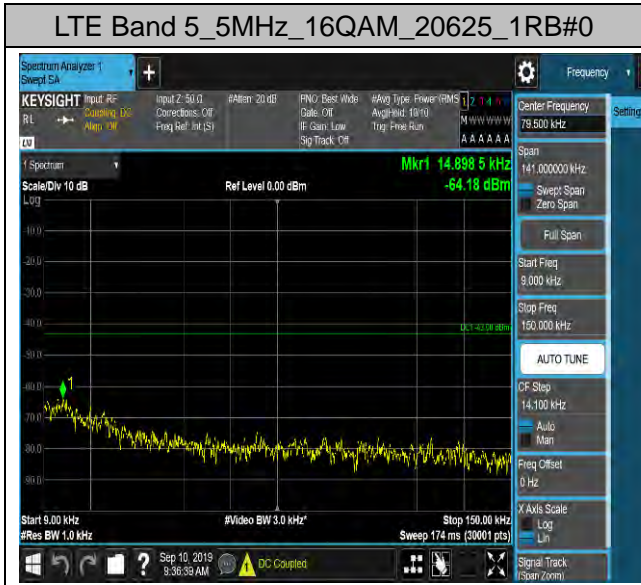

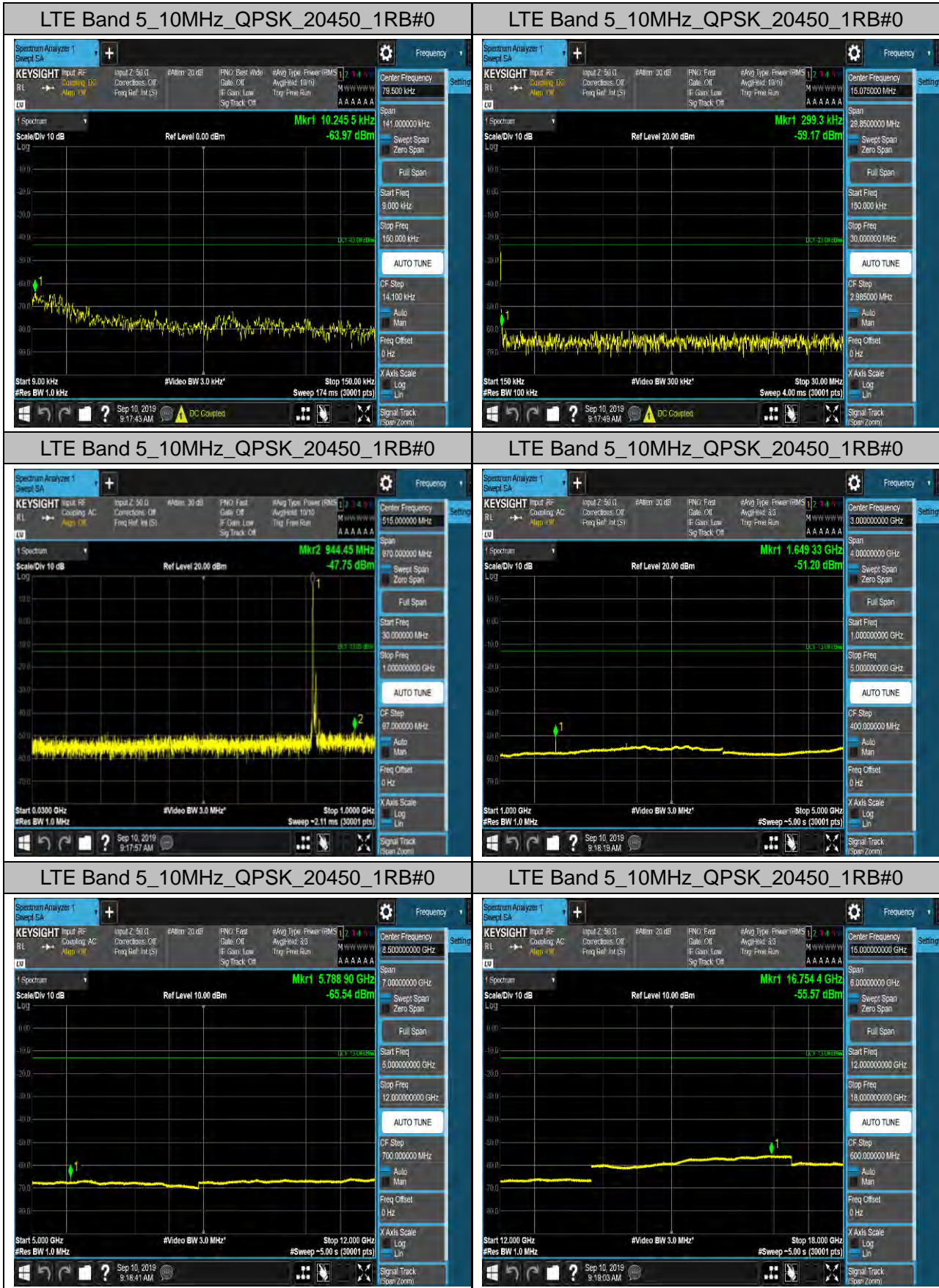

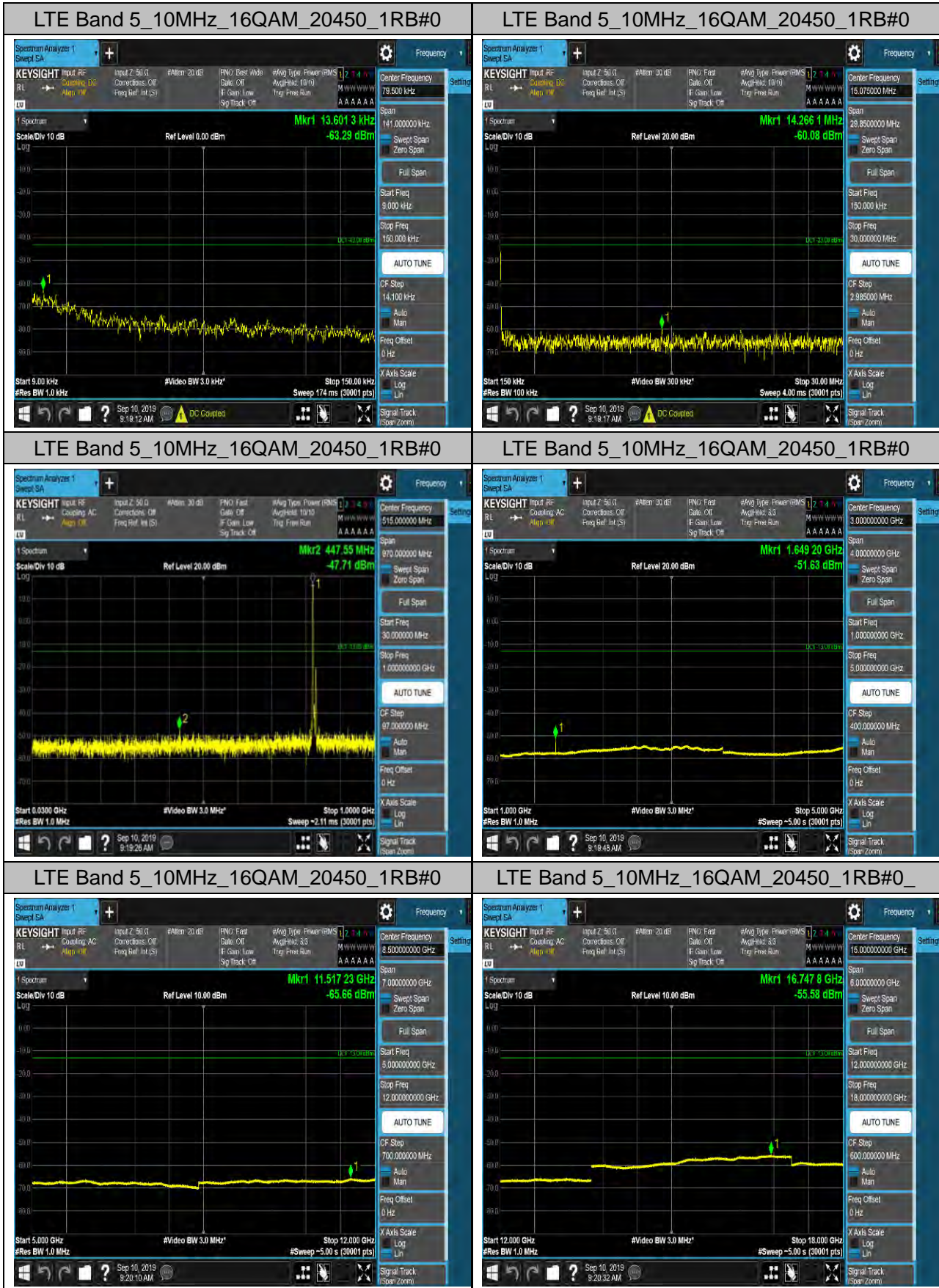

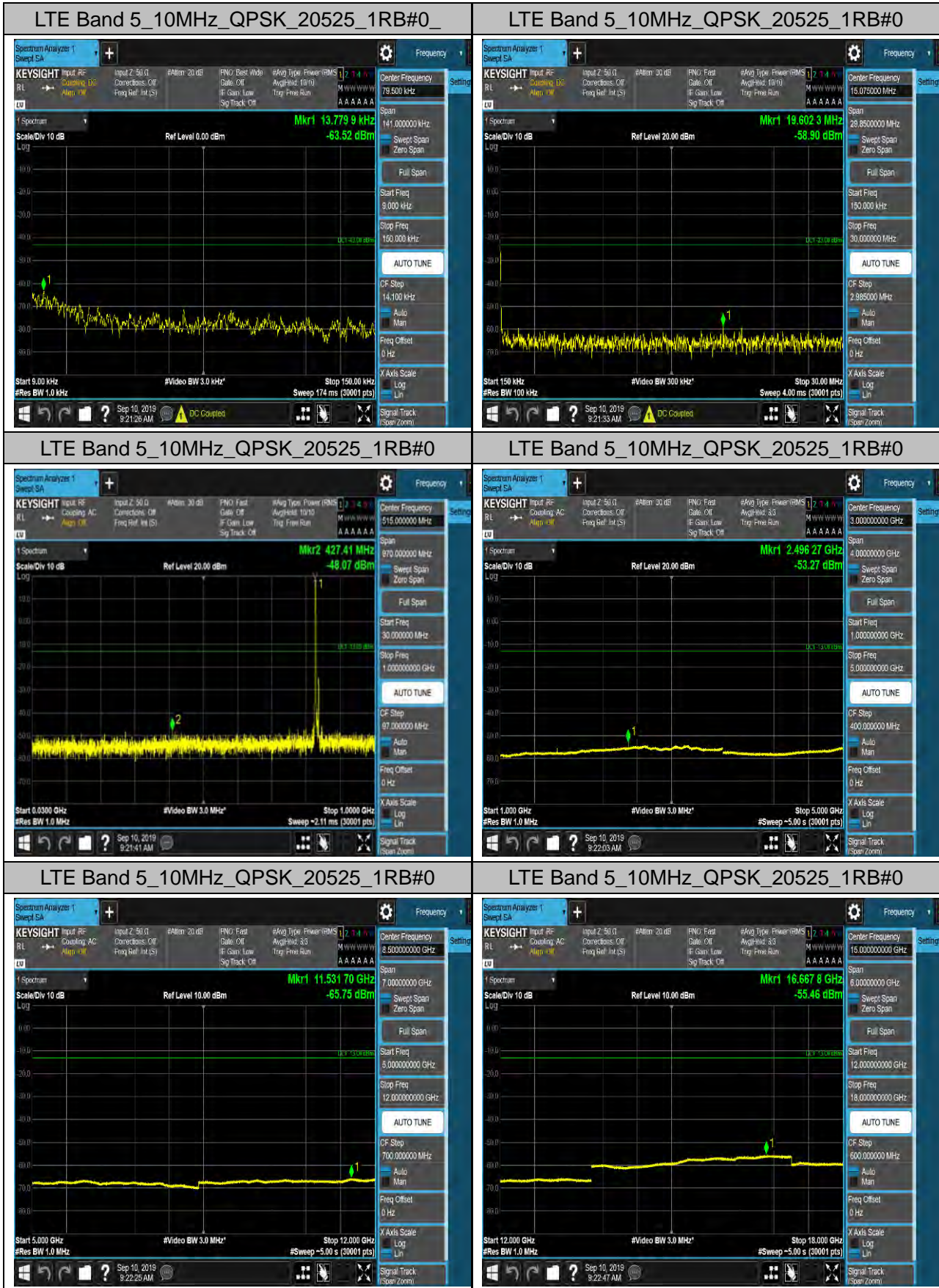

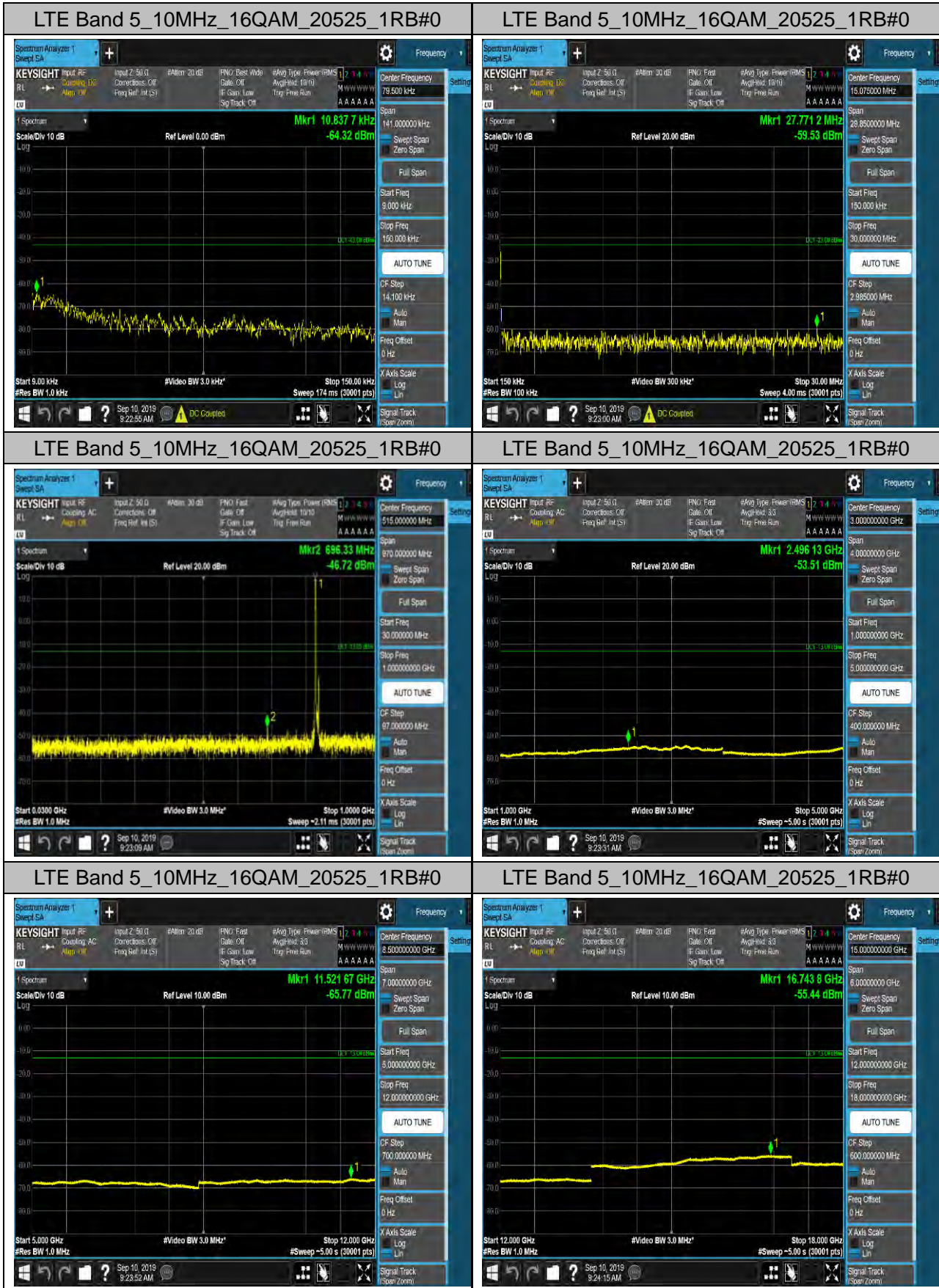

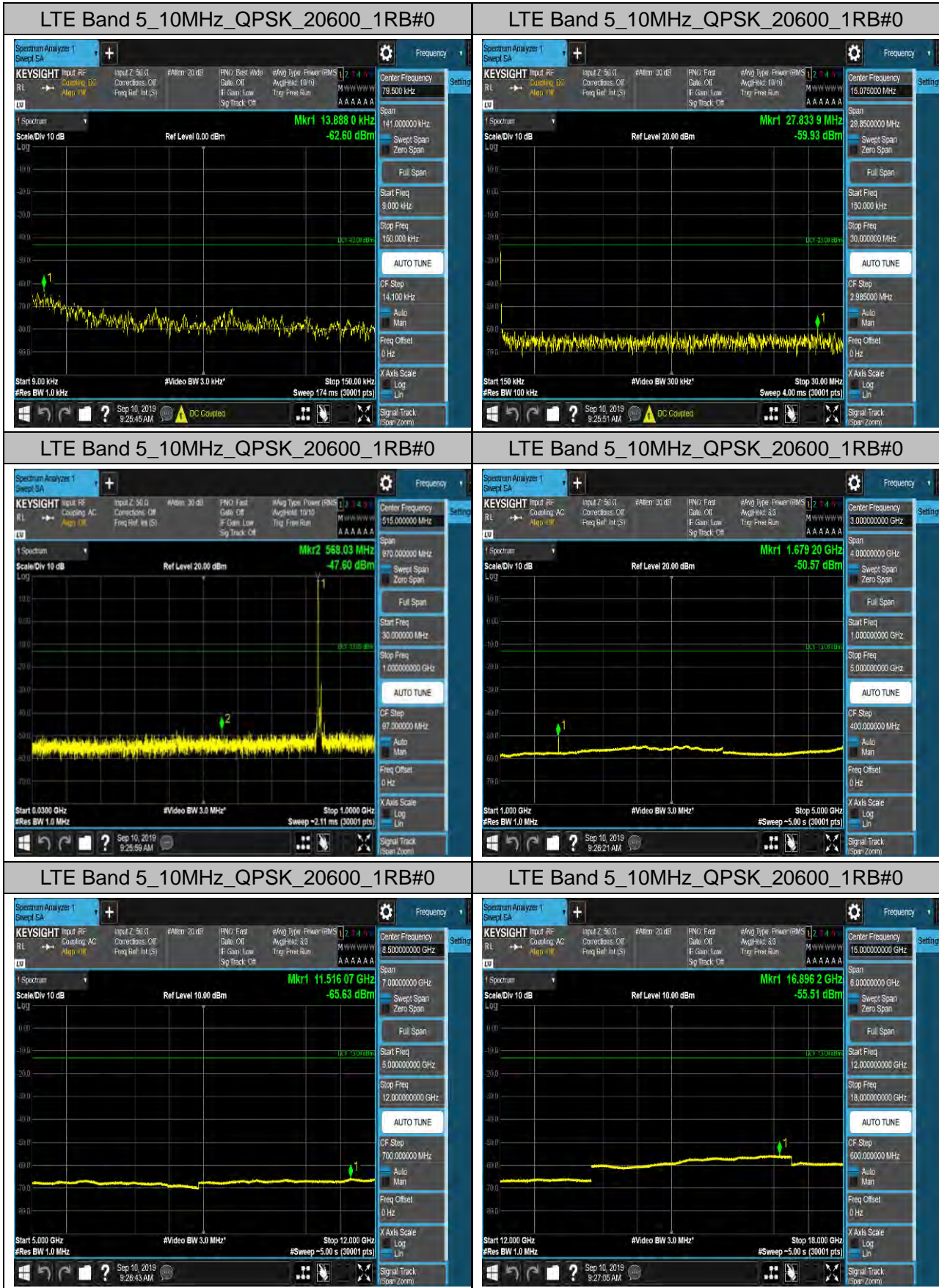

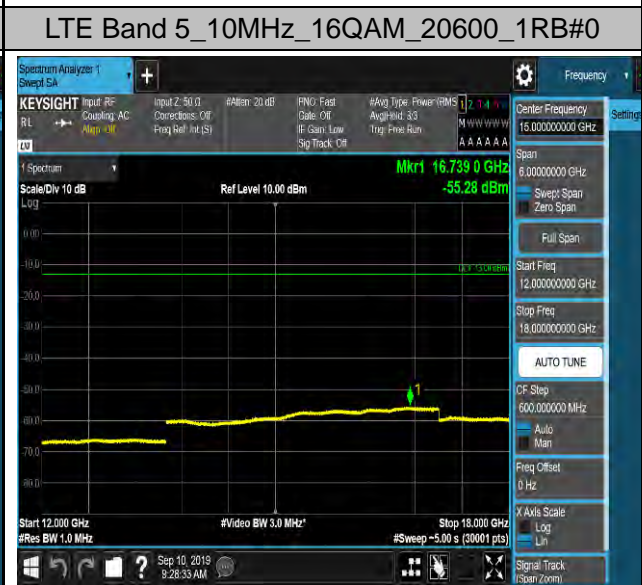
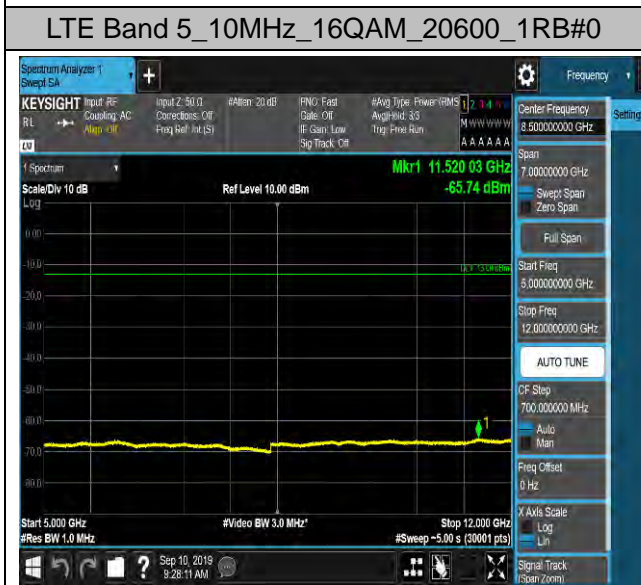
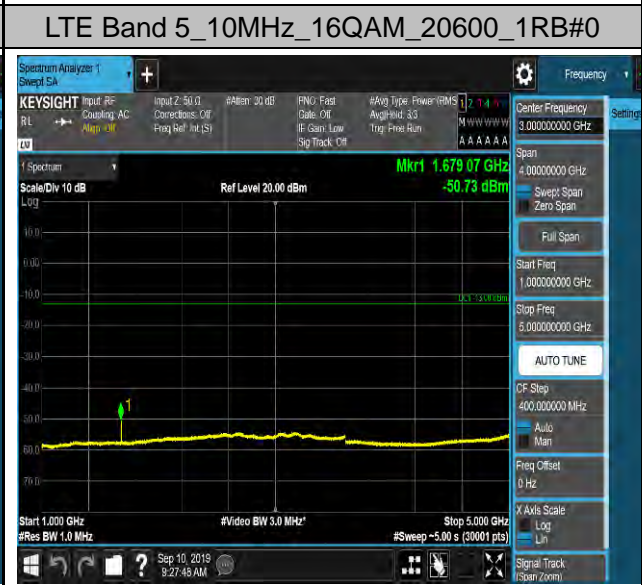
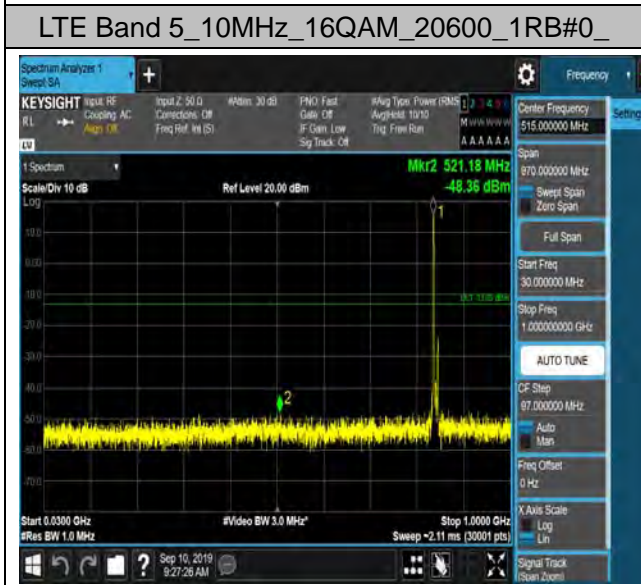
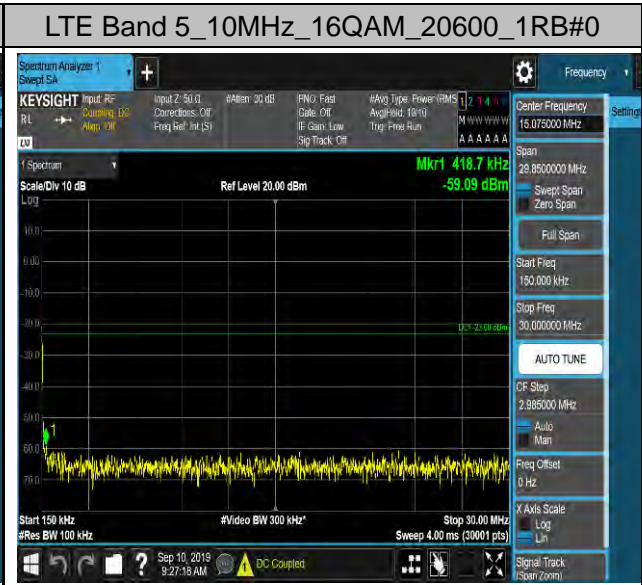
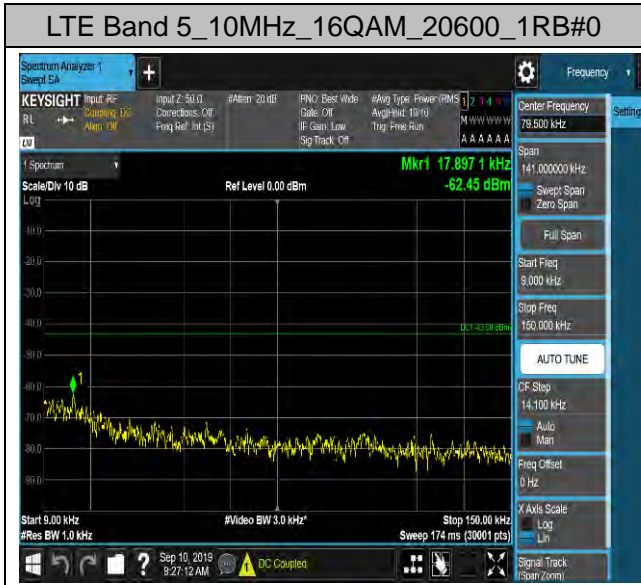

5.8. Radiates Spurious Emission

Ambient condition

Temperature	Relative humidity	Pressure
23°C ~25°C	45%~50%	101.5kPa

Method of Measurement

1. The testing follows FCC KDB 971168 v03r01 Section 5.8 and ANSI C63.26 (2015).
2. Below 1GHz: The EUT is placed on a turntable 0.8 meters above the ground in the chamber, 3 meter away from the antenna. The maximal emission value is acquired by adjusting the antenna height, polarisation and turntable azimuth. Normally, the height range of antenna is 1 m to 4 m, the azimuth range of turntable is 0° to 360°, and the receive antenna has two polarizations Vertical (V) and Horizontal (H). Above 1GHz: (Note: the FCC's permission to use 1.5m as an alternative per TCBC Conf call of Dec. 2, 2014.) The EUT is placed on a turntable 1.5 meters above the ground in the chamber, 3 meter away from the antenna. The maximal emission value is acquired by adjusting the antenna height, polarisation and turntable azimuth. Normally, the height range of antenna is 1 m to 4 m, the azimuth range of turntable is 0° to 360°, and the receive antenna has two polarizations Vertical (V) and Horizontal (H).
3. A loop antenna, A log-periodic antenna or horn antenna shall be substituted in place of the EUT. The log-periodic antenna will be driven by a signal generator and the level will be adjusted till the same power value on the spectrum analyzer or receiver. The level of the spurious emissions can be calculated through the level of the signal generator, cable loss, the gain of the substitution antenna and the reading of the spectrum analyzer or receiver.
4. The EUT is then put into continuously transmitting mode at its maximum power level during the test. Set Test Receiver or Spectrum RBW=200Hz,VBW=600Hz for 9kHz150kHz , RBW=10kHz, VBW=30kHz 150kHz-30MHz , RBW=100kHz,VBW=300kHz for 30MHz to 1GHz and RBW=1MHz, VBW=3MHz for above 1GHz, And the maximum value of the receiver should be recorded as (Pr).
5. The EUT shall be replaced by a substitution antenna. In the chamber, an substitution antenna for the frequency band of interest is placed at the reference point of the chamber. An RF Signal source for the frequency band of interest is connected to the substitution antenna with a cable that has been constructed to not interfere with the radiation pattern of the antenna. A power (PMea) is applied to the input of the substitution antenna, and adjust the level of the signal generator output until the value of the receiver reach the previously recorded (Pr). The power of signal source (PMea) is recorded. The test should be performed by rotating the test item and adjusting the receiving antenna polarization.
6. A amplifier should be connected to the Signal Source output port. And the cable should be connect between the Amplifier and the Substitution Antenna. The cable loss (Pcl) ,the Substitution Antenna Gain (Ga) and the Amplifier Gain (PAg) should be recorded after test.
7. The measurement results are obtained as described below:
$$\text{Power(EIRP)} = \text{PMea} - \text{PAg} - \text{Pcl} + \text{Ga}$$

The measurement results are amend as described below:
$$\text{Power(EIRP)} = \text{PMea} - \text{Pcl} + \text{Ga}$$
8. This value is EIRP since the measurement is calibrated using an antenna of known gain (2.15 dBi)

and known input power. ERP can be calculated from EIRP by subtracting the gain of the dipole, $ERP = EIRP - 2.15\text{dBi}$.

The modulation mode and RB allocation refer to section 5.1, using the maximum output power configuration.

Test setup

9KHz ~ 30MHz

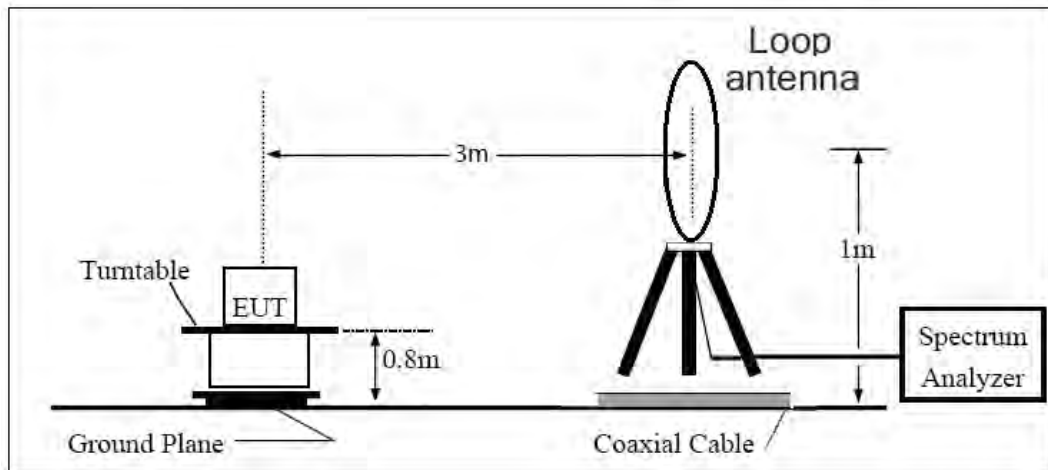

30MHz ~ 1GHz

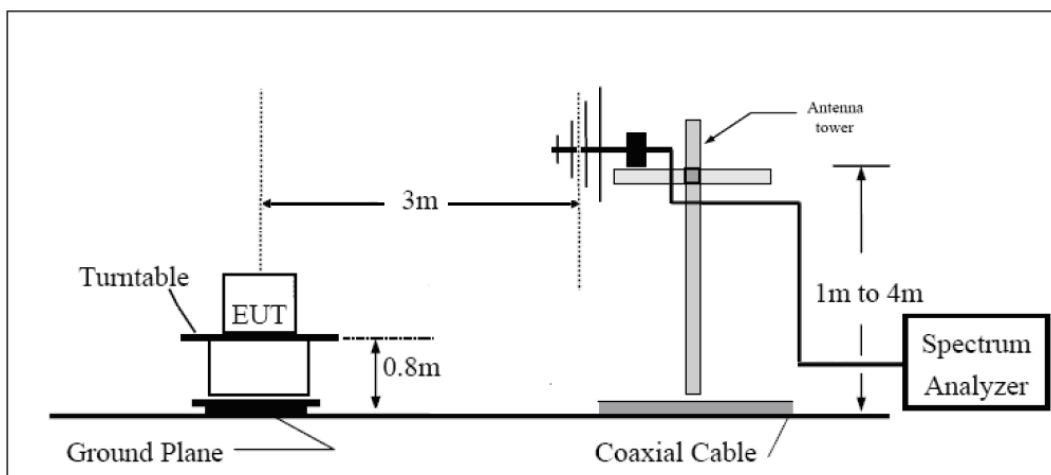

Above 1GHz

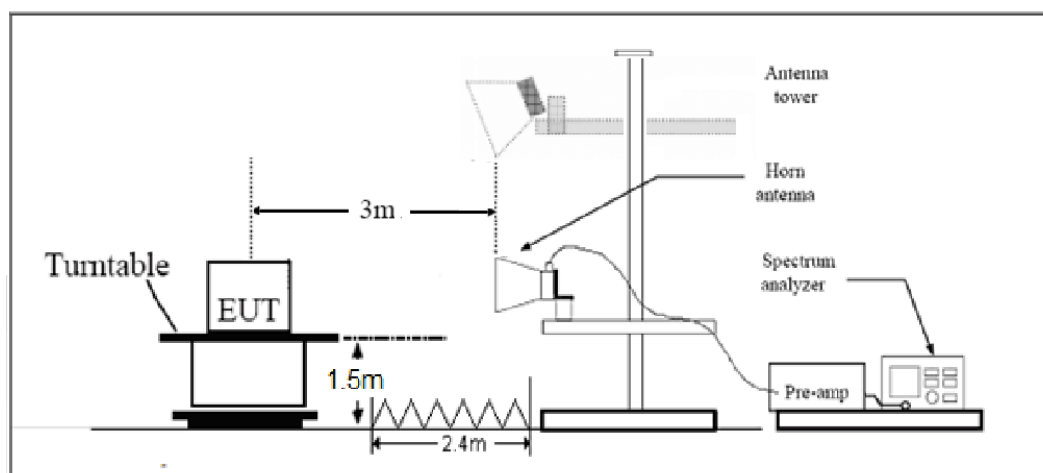



Note: Area side:2.4mX3.6m

Limits

Rule Part 22.917(a) specifies that “The power of any emission outside of the authorized operating frequency ranges must be attenuated below the transmitting power (P) by a factor of at least $43 + 10 \log (P)$ dB.”

Limit	-13 dBm
-------	---------

Measurement Uncertainty

The assessed measurement uncertainty to ensure 95% confidence level for the normal distribution is with the coverage factor $k = 1.96$, $U = 3.55$ dB.

**Test Result**

Sweep the whole frequency band through the range from 9kHz to the 10th harmonic of the carrier, the emissions below the noise floor will not be recorded in the report.

GSM 850 CH-Middle

Harmonic	Frequency (MHz)	SG (dBm)	Cable Loss (dB)	Gain (dBi)	Antenna Polarization	ERP Level (dBm)	Limit (dBm)	Margin (dB)	Azimuth (deg)
2	1673.3	-53.84	2.00	10.75	Horizontal	-47.24	-13.00	34.24	90
3	2510.3	-46.12	2.51	11.05	Horizontal	-39.73	-13.00	26.73	135
4	3346.4	-62.68	4.20	11.15	Horizontal	-57.88	-13.00	44.88	135
5	4183.0	-58.83	5.20	11.15	Horizontal	-55.03	-13.00	42.03	225
6	5019.6	-56.40	5.50	11.95	Horizontal	-52.10	-13.00	39.10	270
7	5856.2	-59.00	5.70	13.55	Horizontal	-53.30	-13.00	40.30	180
8	6692.8	-56.00	6.30	13.75	Horizontal	-50.70	-13.00	37.70	90
9	7529.4	-55.70	6.80	13.85	Horizontal	-50.80	-13.00	37.80	45
10	8366.0	-54.90	6.90	14.25	Horizontal	-49.70	-13.00	36.70	180

Note: 1.The other Spurious RF Radiated emissions level is no more than noise floor.

2.The worst emission was found in the antenna is Horizontal position.

WCDMA Band V CH-Middle

Harmonic	Frequency (MHz)	SG (dBm)	Cable Loss (dB)	Gain (dBi)	Antenna Polarization	ERP Level (dBm)	Limit (dBm)	Margin (dB)	Azimuth (deg)
2	1673	-64.90	2.00	10.75	Horizontal	-58.30	-13.00	45.30	135
3	2510	-65.69	2.51	11.05	Horizontal	-59.30	-13.00	46.30	90
4	3346	-62.60	4.20	11.15	Horizontal	-57.80	-13.00	44.80	90
5	4183	-59.20	5.20	11.15	Horizontal	-55.40	-13.00	42.40	135
6	5020	-57.90	5.50	11.95	Horizontal	-53.60	-13.00	40.60	270
7	5856	-60.30	5.70	13.55	Horizontal	-54.60	-13.00	41.60	315
8	6693	-57.50	6.30	13.75	Horizontal	-52.20	-13.00	39.20	180
9	8366	-56.10	6.80	13.85	Horizontal	-51.20	-13.00	38.20	225
10	3346	-54.60	6.90	14.25	Horizontal	-49.40	-13.00	36.40	45

Note: 1.The other Spurious RF Radiated emissions level is no more than noise floor.

2.The worst emission was found in the antenna is Horizontal position.



LTE Band 5 1.4MHz CH-Middle

Harmonic	Frequency (MHz)	SG (dBm)	Cable Loss (dB)	Gain (dBi)	Antenna Polarization	ERP Level (dBm)	Limit (dBm)	Margin (dB)	Azimuth (deg)
2	1673.0	-63.57	2.00	10.75	Horizontal	-56.97	-13.0	43.97	135
3	2509.5	-65.19	2.51	11.05	Horizontal	-58.80	-13.00	45.80	90
4	3346.0	-55.03	4.20	11.15	Horizontal	-50.23	-13.00	37.23	135
5	4182.5	-59.75	5.20	11.15	Horizontal	-55.95	-13.00	42.95	270
6	5019.0	-58.22	5.50	11.95	Horizontal	-53.92	-13.00	40.92	90
7	5855.5	-60.44	5.70	13.55	Horizontal	-54.74	-13.00	41.74	0
8	6692.0	-47.43	6.30	13.75	Horizontal	-42.13	-13.00	29.13	225
9	7528.5	-53.21	6.80	13.85	Horizontal	-48.31	-13.00	35.31	180
10	8365.0	-55.16	6.90	14.25	Horizontal	-49.96	-13.00	36.96	315

Note: 1.The other Spurious RF Radiated emissions level is no more than noise floor.
2.The worst emission was found in the antenna is Horizontal position.

LTE Band 5 5MHz CH-Middle

Harmonic	Frequency (MHz)	SG (dBm)	Cable Loss (dB)	Gain (dBi)	Antenna Polarization	ERP Level (dBm)	Limit (dBm)	Margin (dB)	Azimuth (deg)
2	1673.0	-64.10	2.00	10.75	Horizontal	-57.50	-13.00	44.50	225
3	2509.5	-65.09	2.51	11.05	Horizontal	-58.70	-13.00	45.70	45
4	3346.0	-56.39	4.20	11.15	Horizontal	-51.59	-13.0	38.59	90
5	4182.5	-58.78	5.20	11.15	Horizontal	-54.98	-13.0	41.98	135
6	5019.0	-58.25	5.50	11.95	Horizontal	-53.95	-13.0	40.95	315
7	5855.5	-59.69	5.70	13.55	Horizontal	-53.99	-13.0	40.99	225
8	6692.0	-57.65	6.30	13.75	Horizontal	-52.35	-13.0	39.35	180
9	7528.5	-55.80	6.80	13.85	Horizontal	-50.90	-13.0	37.90	45
10	8365.0	-55.78	6.90	14.25	Horizontal	-50.58	-13.0	37.58	0

Note: 1.The other Spurious RF Radiated emissions level is no more than noise floor.
2.The worst emission was found in the antenna is Horizontal position.



LTE Band 5 10MHz CH-Middle

Harmonic	Frequency (MHz)	SG (dBm)	Cable Loss (dB)	Gain (dBi)	Antenna Polarization	ERP Level (dBm)	Limit (dBm)	Margin (dB)	Azimuth (deg)
2	1673.0	-65.64	2.00	10.75	Horizontal	-59.04	-13.00	46.04	0
3	2509.5	-65.78	2.51	11.05	Horizontal	-59.39	-13.00	46.39	270
4	3346.0	-57.38	4.20	11.15	Horizontal	-52.58	-13.0	39.58	270
5	4182.5	-59.20	5.20	11.15	Horizontal	-55.40	-13.0	42.40	225
6	5019.0	-58.27	5.50	11.95	Horizontal	-53.97	-13.0	40.97	0
7	5855.5	-59.90	5.70	13.55	Horizontal	-54.20	-13.0	41.20	180
8	6692.0	-57.60	6.30	13.75	Horizontal	-52.30	-13.0	39.30	315
9	7528.5	-55.40	6.80	13.85	Horizontal	-50.50	-13.0	37.50	270
10	8365.0	-55.80	6.90	14.25	Horizontal	-50.60	-13.0	37.60	135

Note: 1.The other Spurious RF Radiated emissions level is no more than noise floor.

2.The worst emission was found in the antenna is Horizontal position.

6. Main Test Instruments

Name	Manufacturer	Type	Serial Number	Calibration Date	Expiration Date
Base Station Simulator	R&S	CMW500	113824	2019-05-19	2020-05-18
Power Splitter	Hua Xiang	SHX-GF2-2-13	10120101	/	/
Spectrum Analyzer	Key sight	N9010A	MY50210259	2019-05-19	2020-05-18
Universal Radio Communication Tester	Key sight	E5515C	MY48367192	2019-05-19	2020-05-18
Signal Analyzer	R&S	FSV30	100815	2018-12-16	2019-12-15
Loop Antenna	SCHWARZBECK	FMZB1519	1519-047	2019-09-26	2021-09-25
Trilog Antenna	SCHWARZBECK	VUBL 9163	9163-201	2017-11-18	2019-11-17
Horn Antenna	R&S	HF907	100126	2018-07-07	2020-07-06
Horn Antenna	ETS-Lindgren	3160-09	00102643	2018-06-20	2020-06-19
Signal generator	R&S	SMB 100A	102594	2019-05-19	2020-05-18
Climatic Chamber	ESPEC	SU-242	93000506	2017-12-17	2020-12-16
Preamplifier	R&S	SCU18	102327	2019-05-19	2020-05-18
MOB COMMS DC SUPPLY	Keysight	66319D	MY43004105	2019-05-20	2020-05-21
RF Cable	Agilent	SMA 15cm	0001	2019-09-14	2019-12-13
Software	R&S	EMC32	9.26.0	/	/

*****END OF REPORT *****