

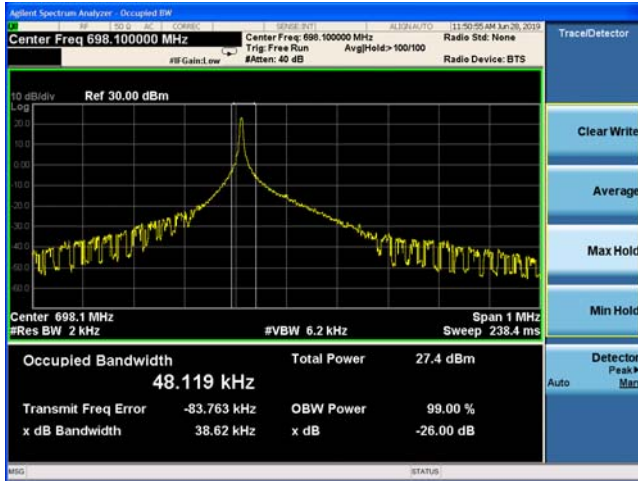

### NB-IOT Band 85 BPSK 3.75KHz 1@0 CH-Low

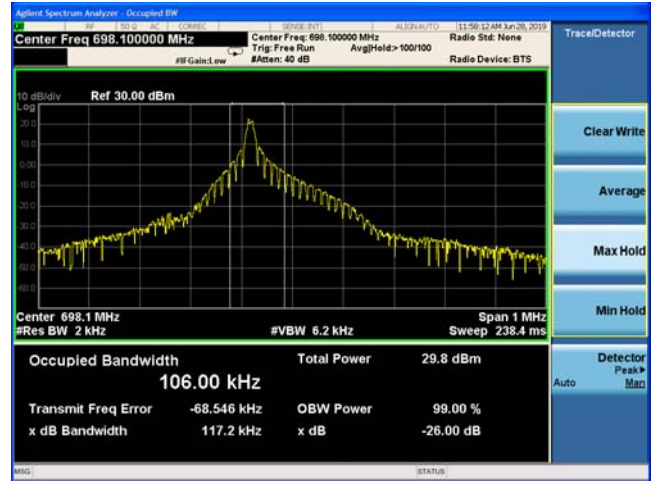

### NB-IOT Band 85 BPSK 15KHz 1@0 CH-Low



### NB-IOT Band 85 BPSK 3.75KHz 1@0 CH-Middle

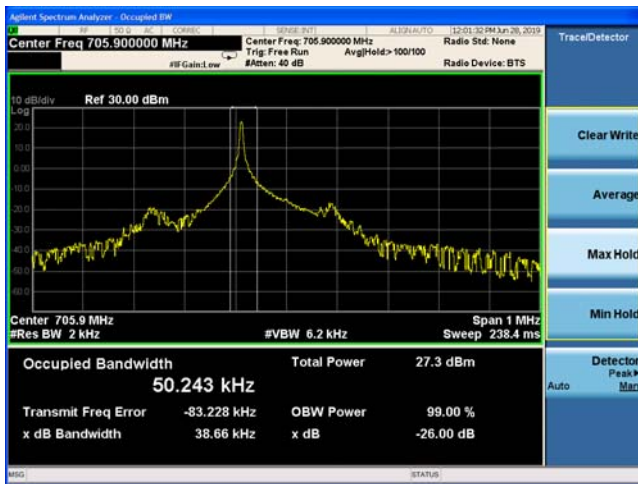

### NB-IOT Band 85 BPSK 15KHz 1@0 CH-Middle

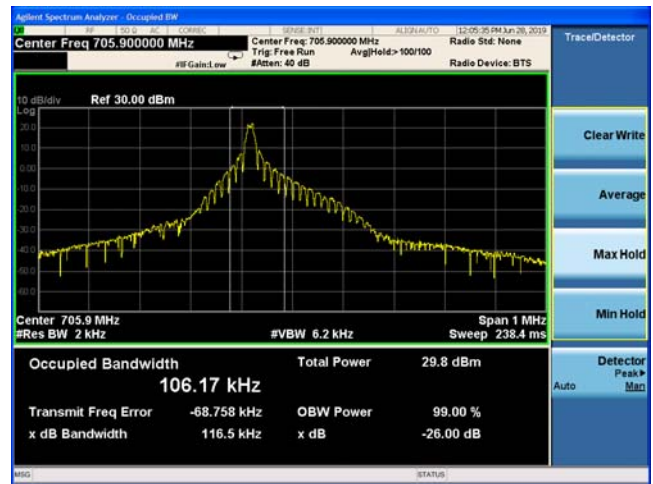

### NB-IOT Band 85 BPSK 3.75KHz 1@0 CH-High

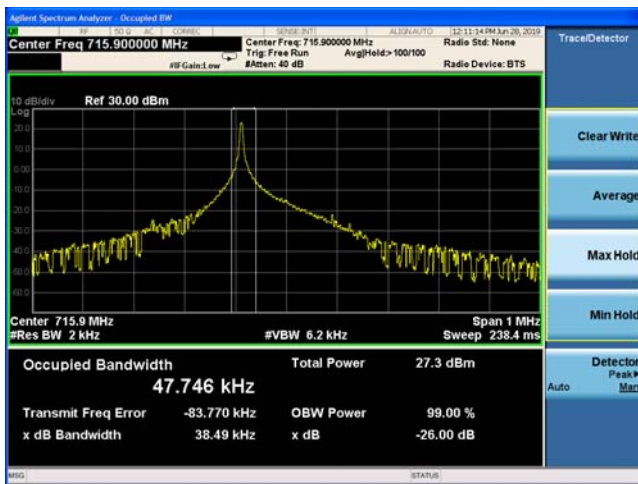

### NB-IOT Band 85 BPSK 15KHz 1@0 CH-High

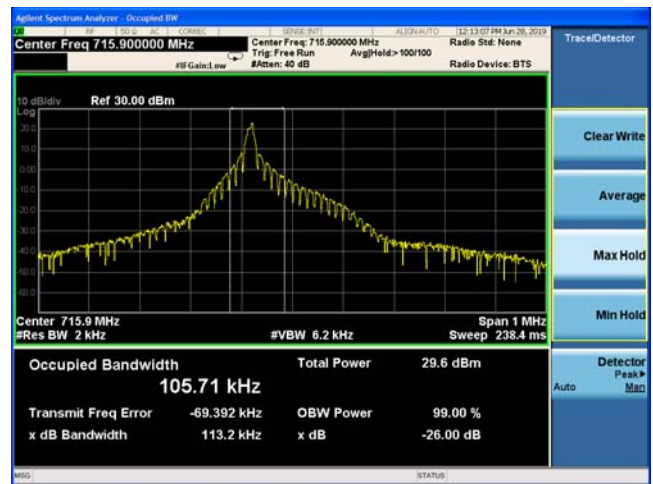

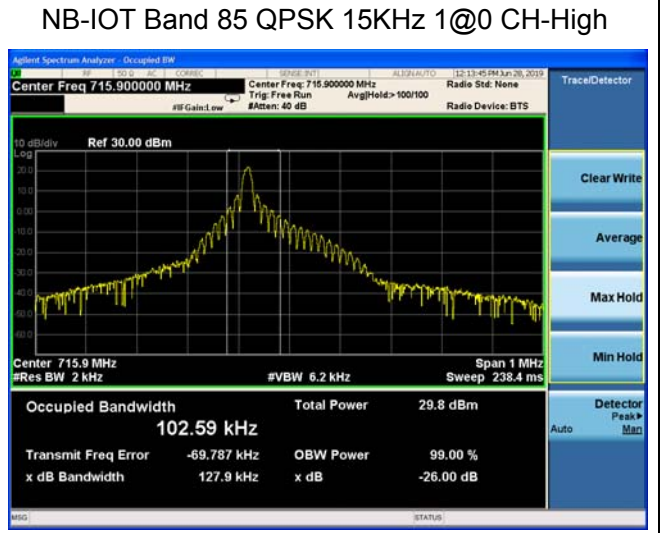
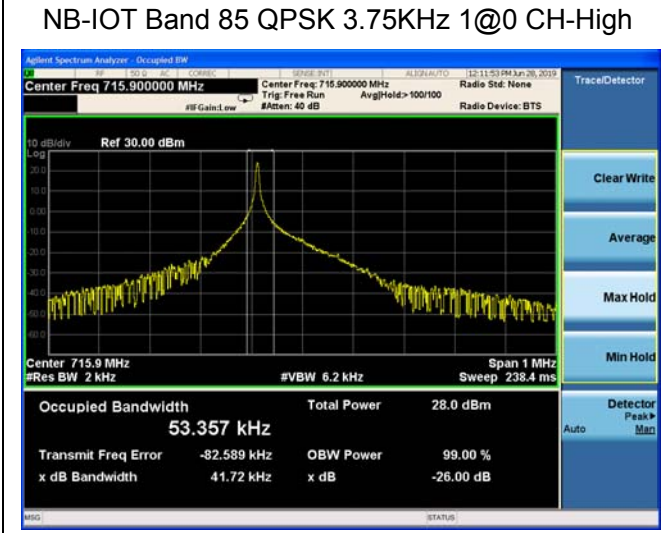
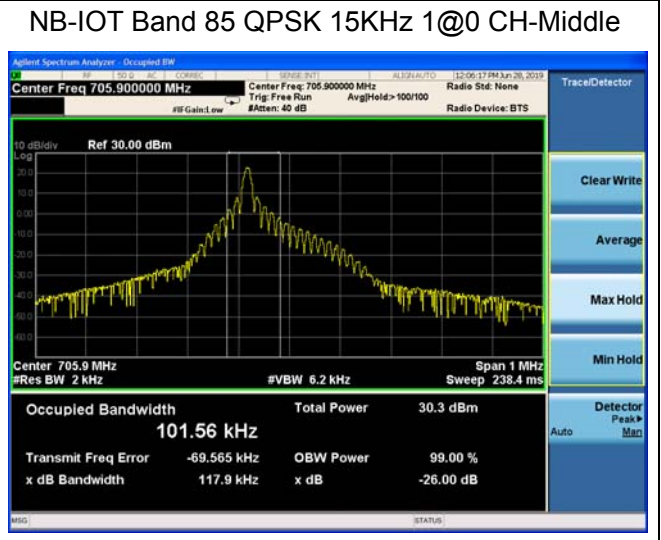
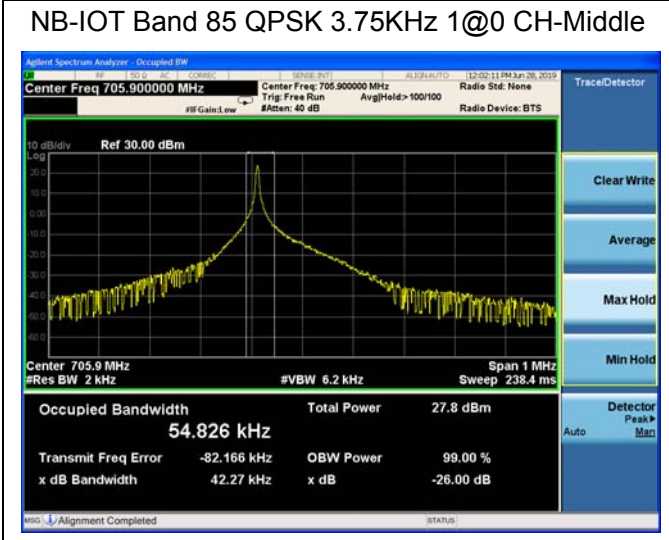
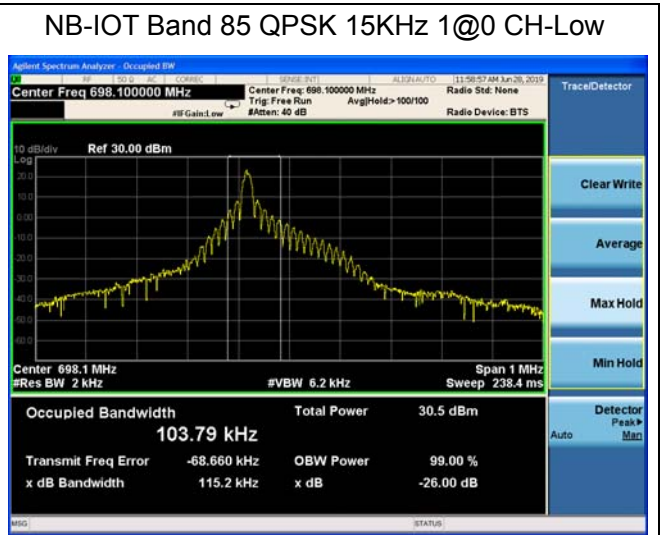
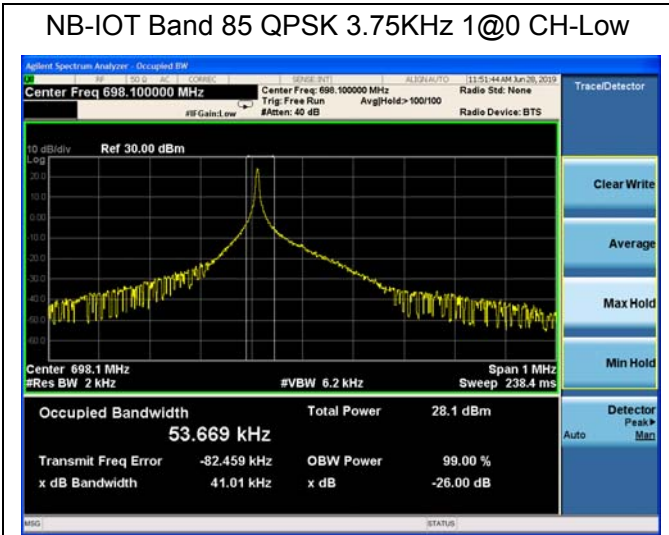

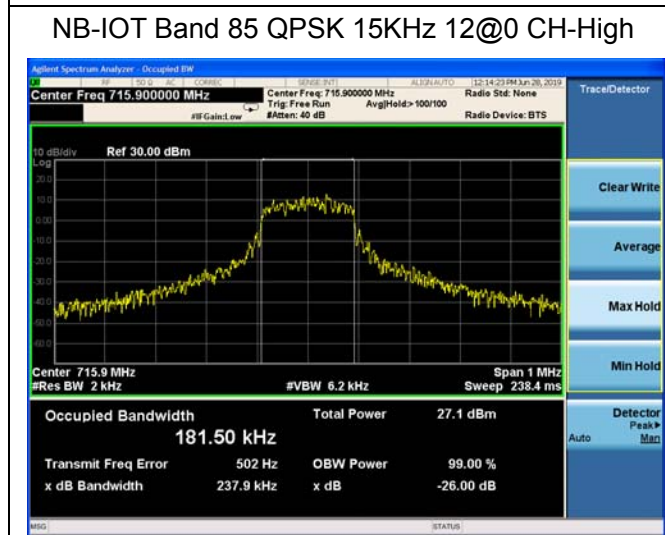
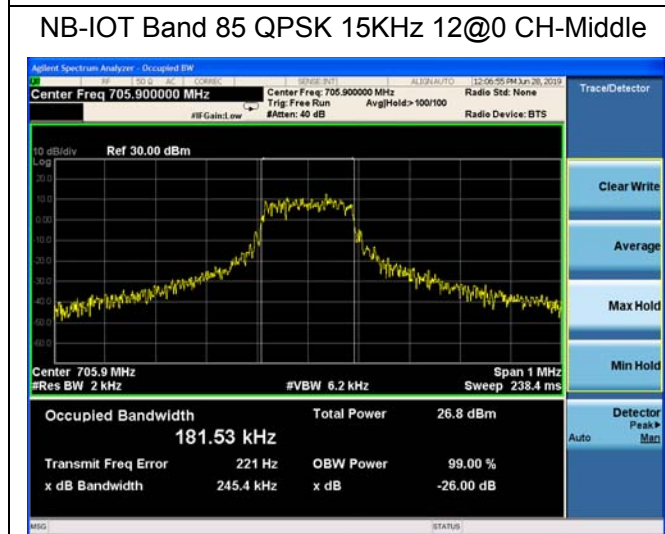
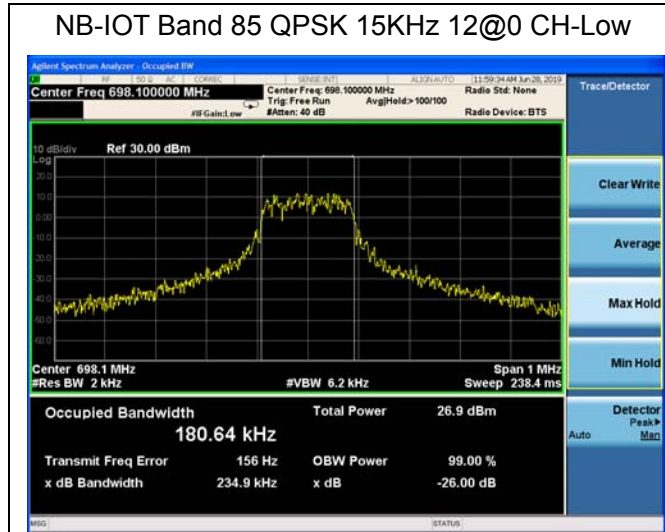

### 5.4 Band Edge Compliance

#### Ambient condition

Temperature	Relative humidity	Pressure
23°C ~25°C	45%~50%	101.5kPa

#### Method of Measurement

The EUT was connected to Spectrum Analyzer and Base Station Simulator via power Splitter. The band edge of the lowest and highest channels were measured.

The testing follows KDB 971168 D01 v03r01 Section 6.0

The EUT was connected to spectrum analyzer and system simulator via a power divider.

The band edges of low and high channels for the highest RF powers were measured.

RBW is set to 51Hz, VBW is set to 160Hz for 3.75KHz full carrier,

RBW is set to 200Hz, VBW is set to 620Hz for 15KHz full carrier,

Set spectrum analyzer with RMS detector.

The RF fundamental frequency should be excluded against the limit line in the operating frequency band.

Checked that all the results comply with the emission limit line.

#### Test Setup

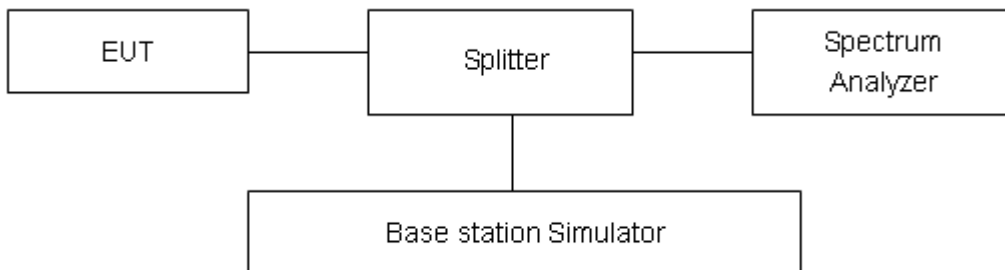

#### Limits

Rule Part 27.53(i) By a factor of not less than  $43 + 10 \log (P)$  dB on all frequencies between 2305 and 2320 MHz.

Rule Part 27.53(h) specifies that “ for operations in the 1695-1710 MHz, 1710-1755 MHz, 1755-1780 MHz, 1915-1920 MHz, 1995-2000 MHz, 2000-2020 MHz, 2110-2155 MHz, 2155-2180 MHz, and 2180-2200 bands, the power of any emission outside a licensee’s frequency block shall be attenuated below the transmitter power (P) in watts by at least  $43 + 10 \log_{10} (P)$  dB”

Rule Part 27.53(g) For operations in the 600 MHz band and the 698-746 MHz band, the power of any



emission outside a licensee's frequency band(s) of operation shall be attenuated below the transmitter power (P) within the licensed band(s) of operation, measured in watts, by at least  $43 + 10 \log (P)$  dB. Compliance with this provision is based on the use of measurement instrumentation employing a resolution bandwidth of 100 kilohertz or greater. However, in the 100 kilohertz bands immediately outside and adjacent to a licensee's frequency block, a resolution bandwidth of at least 30 kHz may be employed.

Rule Part 27.53(f) For operations in the 746-758 MHz, 775-788 MHz, and 805-806 MHz bands, emissions in the band 1559-1610 MHz shall be limited to  $-70$  dBW/MHz equivalent isotropically radiated power (EIRP) for wideband signals, and  $-80$  dBW EIRP for discrete emissions of less than 700 Hz bandwidth. For the purpose of equipment authorization, a transmitter shall be tested with an antenna that is representative of the type that will be used with the equipment in normal operation.

Rule Part 27.53 (c) For operations in the 746-758 MHz band and the 776-788 MHz band, the power of any emission outside the licensee's frequency band(s) of operation shall be attenuated below the transmitter power (P) within the licensed band(s) of operation, measured in watts, in accordance with the following:

- (1) On any frequency outside the 746-758 MHz band, the power of any emission shall be attenuated outside the band below the transmitter power (P) by at least  $43 + 10 \log (P)$  dB;
- (2) On any frequency outside the 776-788 MHz band, the power of any emission shall be attenuated outside the band below the transmitter power (P) by at least  $43 + 10 \log (P)$  dB;
- (3) On all frequencies between 763-775 MHz and 793-805 MHz, by a factor not less than  $76 + 10 \log (P)$  dB in a 6.25 kHz band segment, for base and fixed stations;
- (4) On all frequencies between 763-775 MHz and 793-805 MHz, by a factor not less than  $65 + 10 \log (P)$  dB in a 6.25 kHz band segment, for mobile and portable stations;
- (5) Compliance with the provisions of paragraphs (c)(1) and (c)(2) of this section is based on the use of measurement instrumentation employing a resolution bandwidth of 100 kHz or greater. However, in the 100 kHz bands immediately outside and adjacent to the frequency block, a resolution bandwidth of at least 30 kHz may be employed;

### Measurement Uncertainty

The assessed measurement uncertainty to ensure 95% confidence level for the normal distribution is with the coverage factor  $k = 1.96$ ,  $U=0.684$ dB.

**Test Result**

All the test traces in the plots shows the test results clearly.

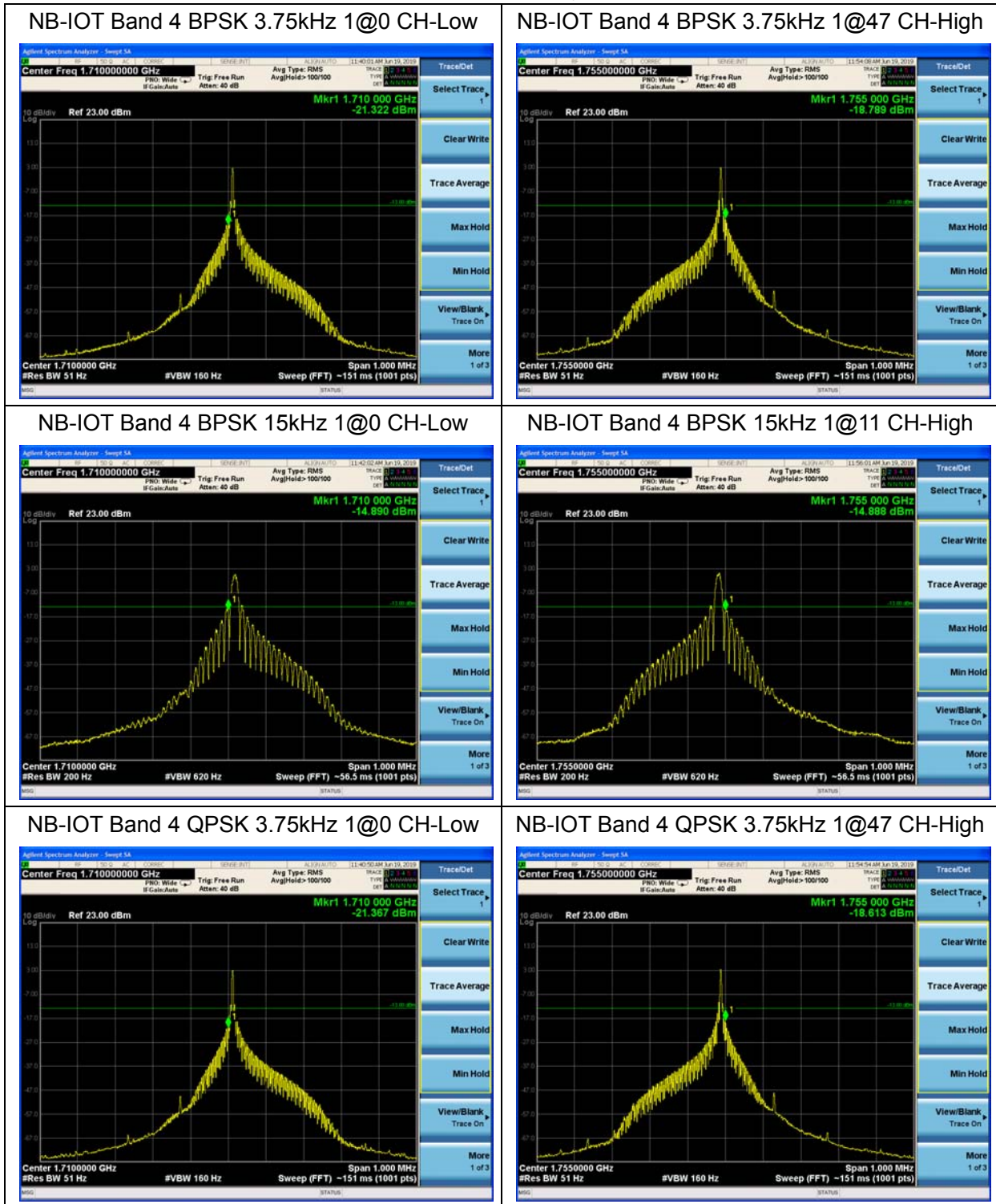



### NB-IOT Band 4 QPSK 15kHz 1@0 CH-Low

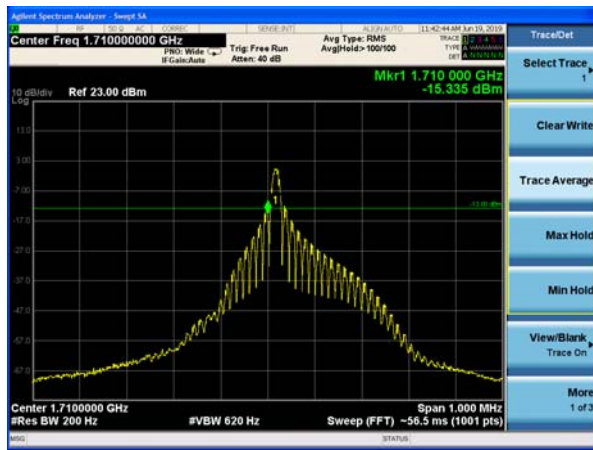

### NB-IOT Band 4 QPSK 15kHz 1@11 CH-High

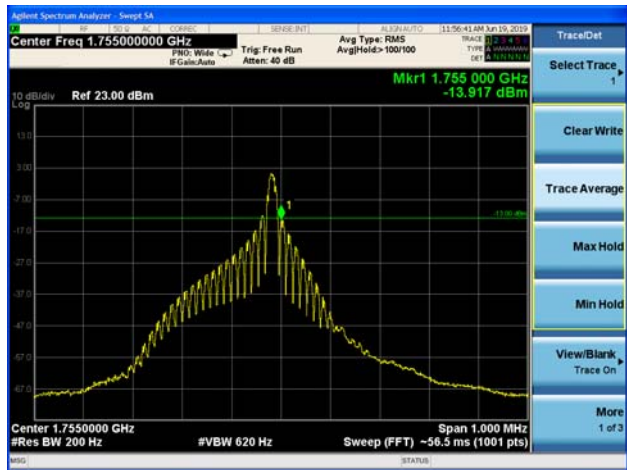

### NB-IOT Band 4 QPSK 15kHz 12@0 CH-Low

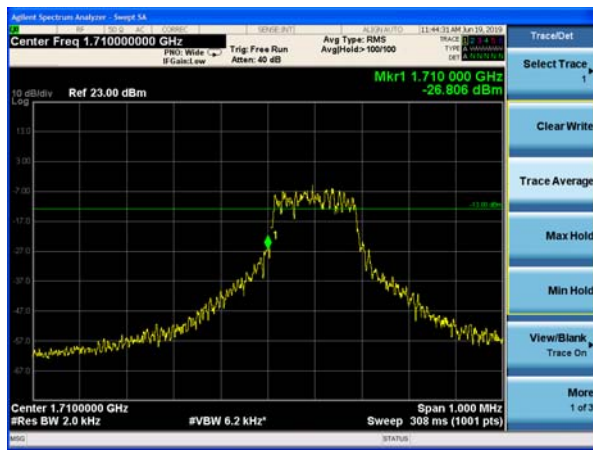

### NB-IOT Band 4 QPSK 15kHz 12@0 CH-High

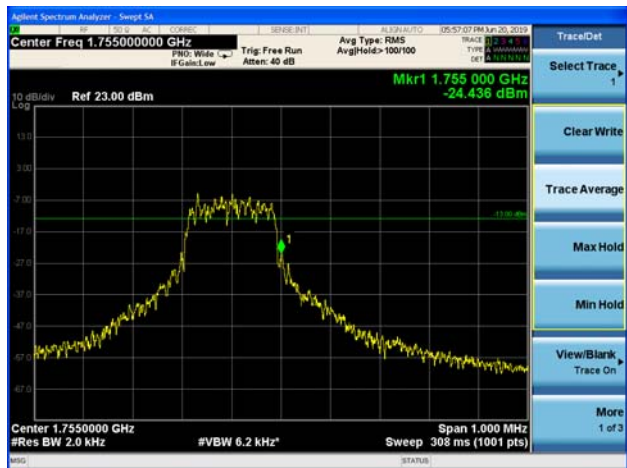





### NB-IOT Band 12 BPSK 3.75kHz 1@0 CH-Low

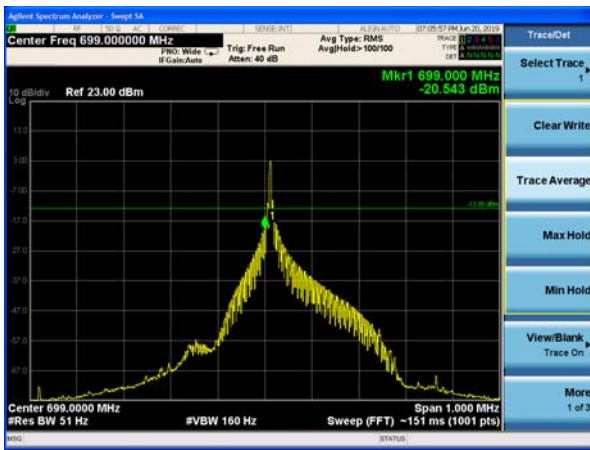

### NB-IOT Band 12 BPSK 3.75kHz 1@47 CH-High

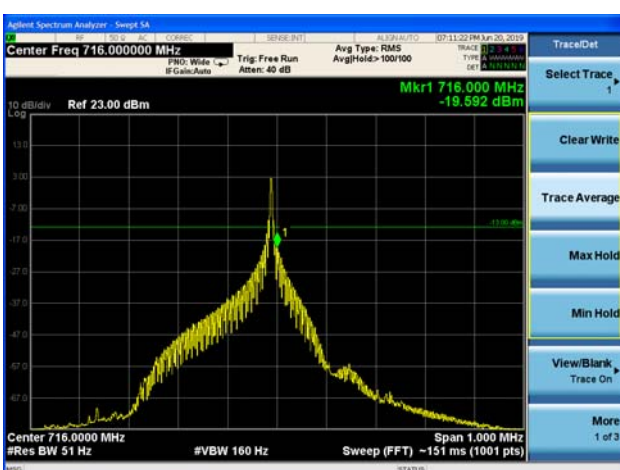

### NB-IOT Band 12 BPSK 15kHz 1@0 CH-Low

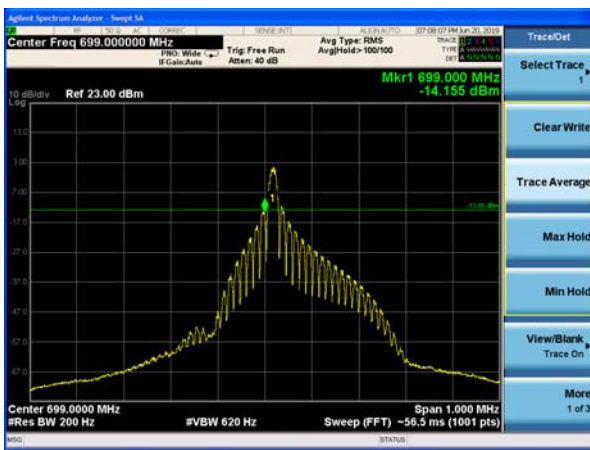

### NB-IOT Band 12 BPSK 15kHz 1@11 CH-High

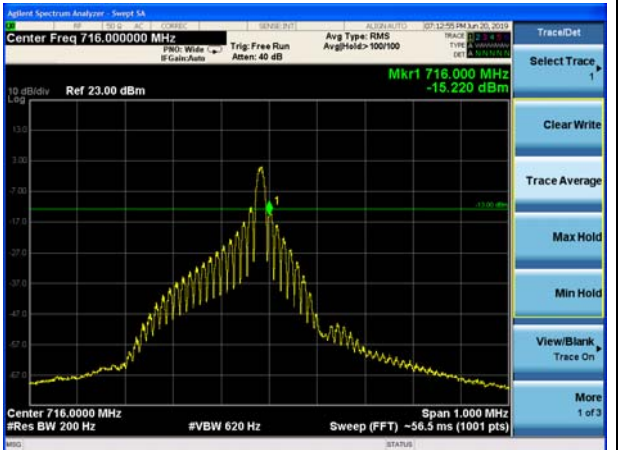

### NB-IOT Band 12 QPSK 3.75kHz 1@0 CH-Low

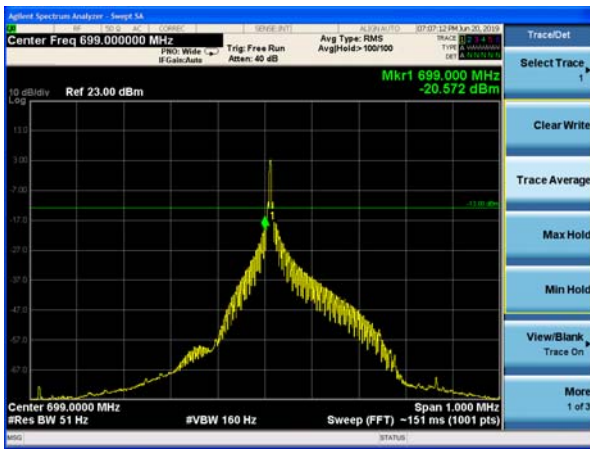

### NB-IOT Band 12 QPSK 3.75kHz 1@47 CH-High

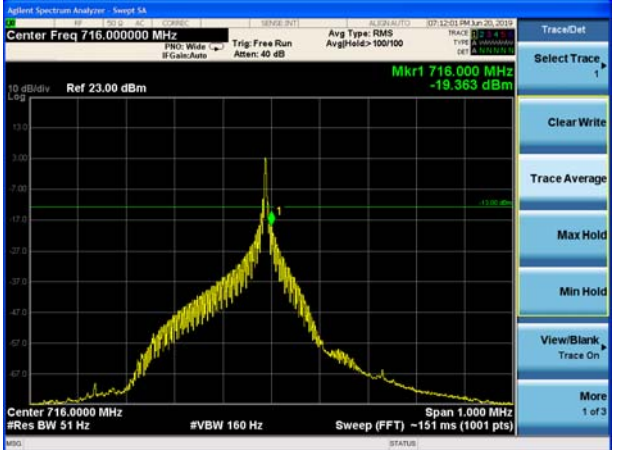



NB-IOT Band 12 QPSK 15kHz 1@0 CH-Low

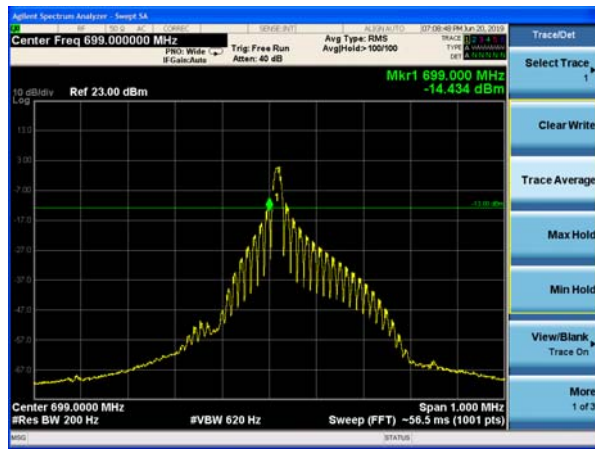

NB-IOT Band 12 QPSK 15kHz 1@11 CH-High

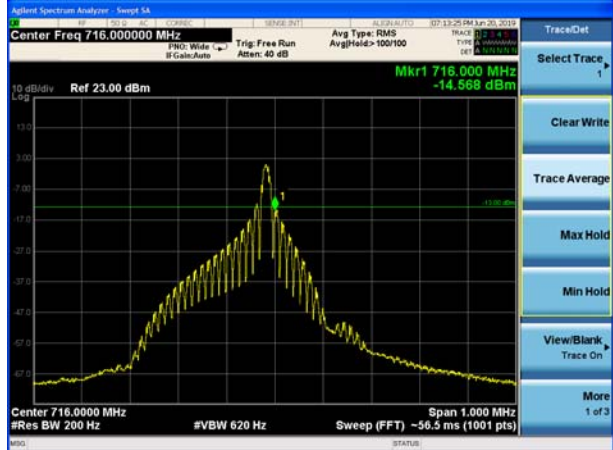

NB-IOT Band 12 QPSK 15kHz 12@0 CH-Low

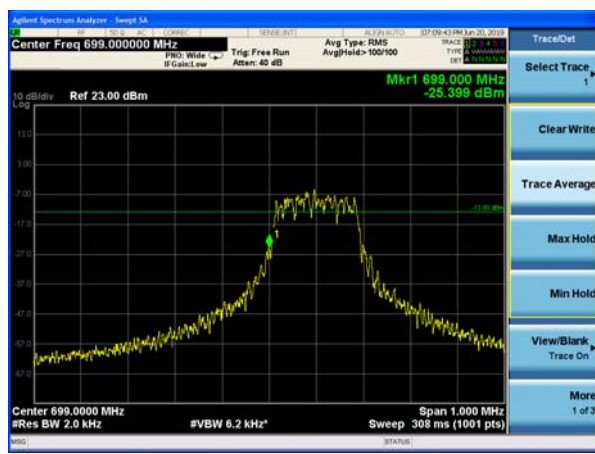

NB-IOT Band 12 QPSK 15kHz 12@0 CH-High

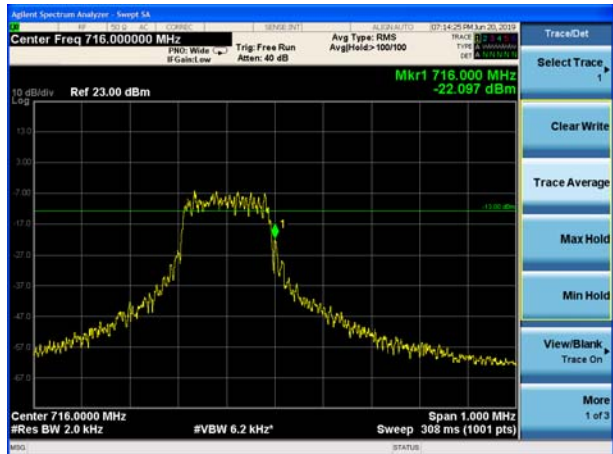



### NB-IOT Band 13 BPSK 3.75kHz 1@0 CH-Low

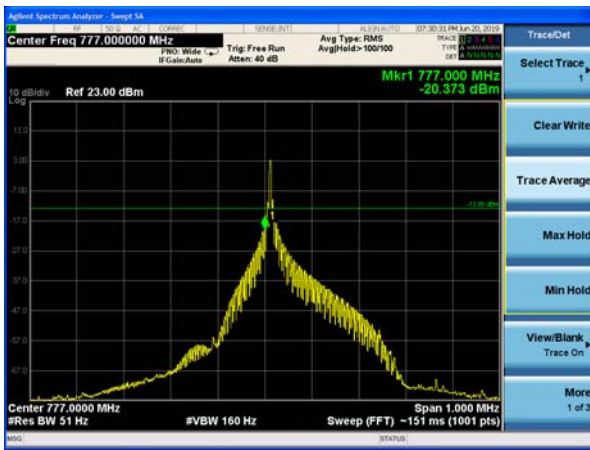

### NB-IOT Band 13 BPSK 3.75kHz 1@47 CH-High

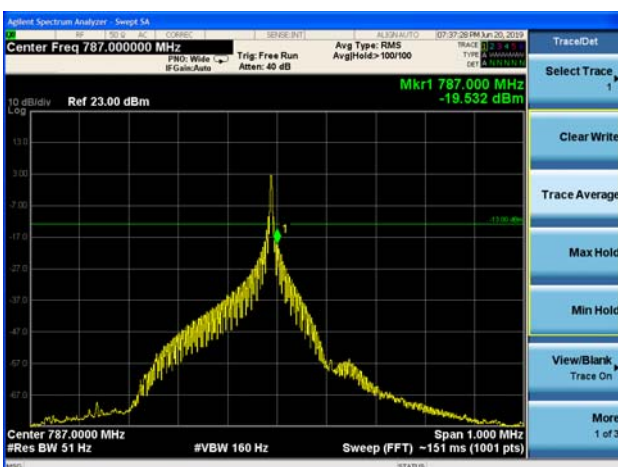

### NB-IOT Band 13 BPSK 15kHz 1@0 CH-Low

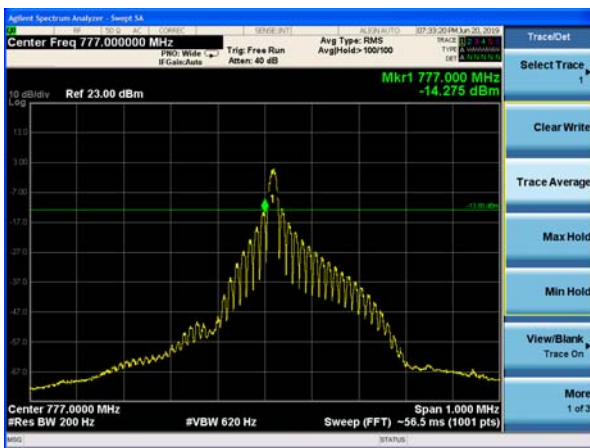

### NB-IOT Band 13 BPSK 15kHz 1@11 CH-High

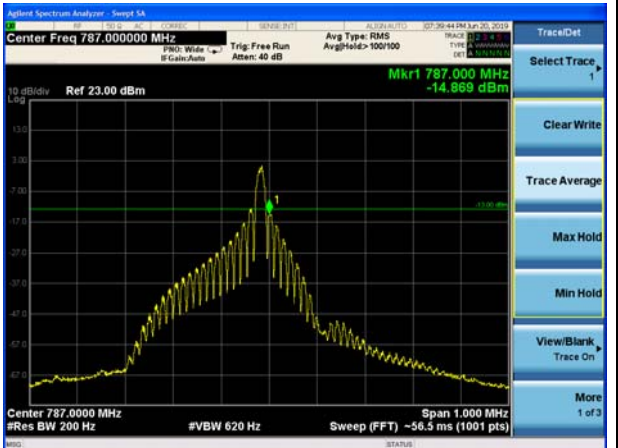

### NB-IOT Band 13 QPSK 3.75kHz 1@0 CH-Low

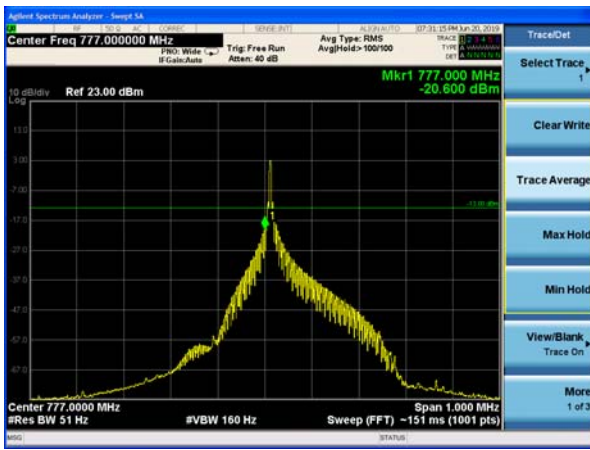

### NB-IOT Band 13 QPSK 3.75kHz 1@47 CH-High

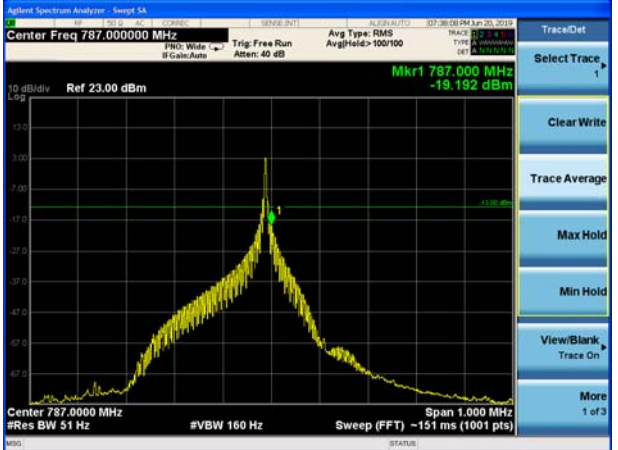



NB-IOT Band 13 QPSK 15kHz 1@0 CH-Low

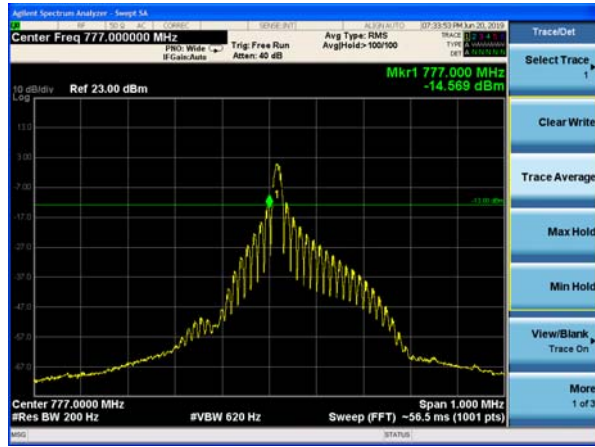

NB-IOT Band 13 QPSK 15kHz 1@11 CH-High

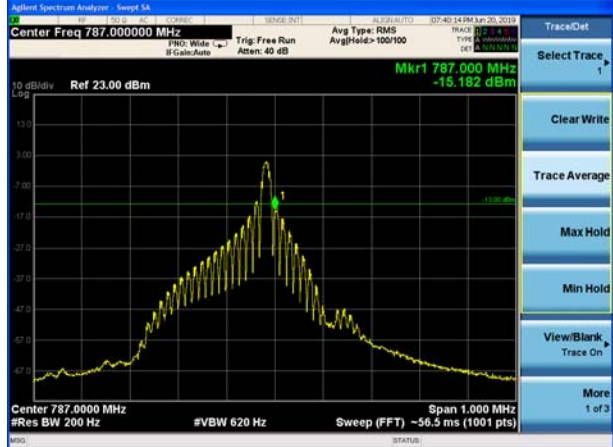

NB-IOT Band 13 QPSK 15kHz 12@0 CH-Low

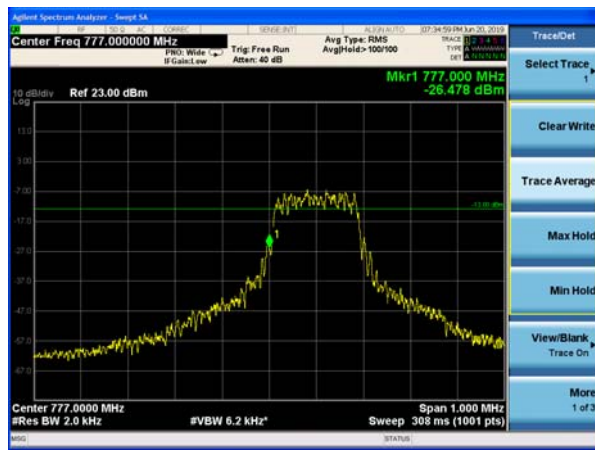

NB-IOT Band 13 QPSK 15kHz 12@0 CH-High

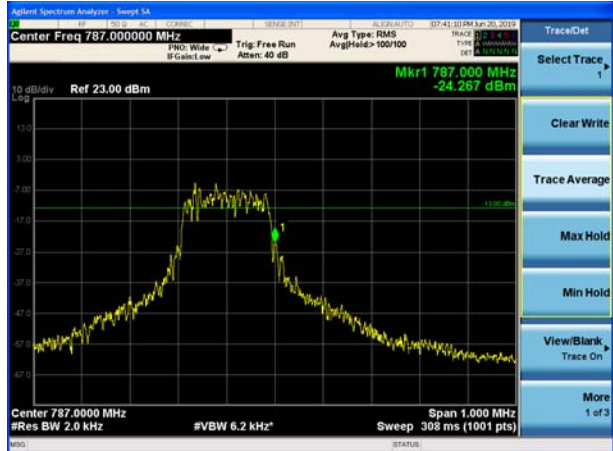



### NB-IOT Band 17 BPSK 3.75kHz 1@0 CH-Low

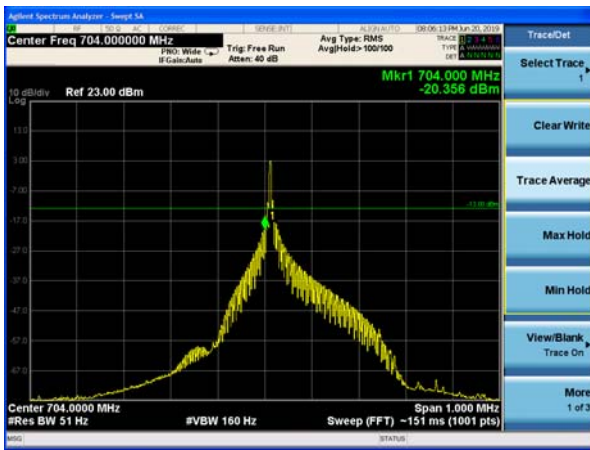

### NB-IOT Band 17 BPSK 3.75kHz 1@47 CH-High

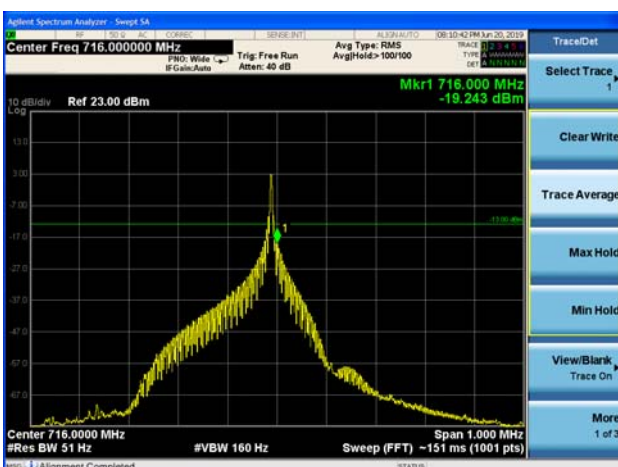

### NB-IOT Band 17 BPSK 15kHz 1@0 CH-Low

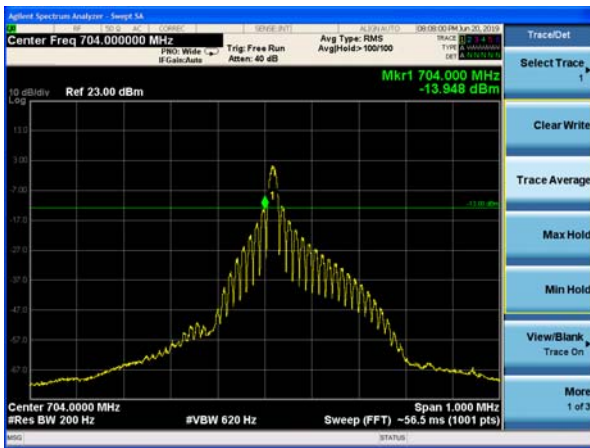

### NB-IOT Band 17 BPSK 15kHz 1@11 CH-High

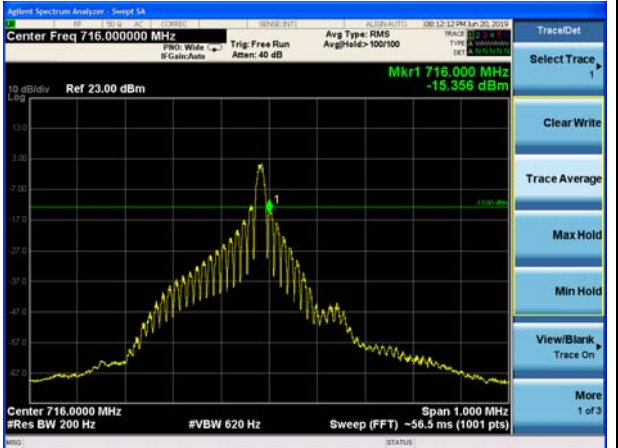

### NB-IOT Band 17 QPSK 3.75kHz 1@0 CH-Low

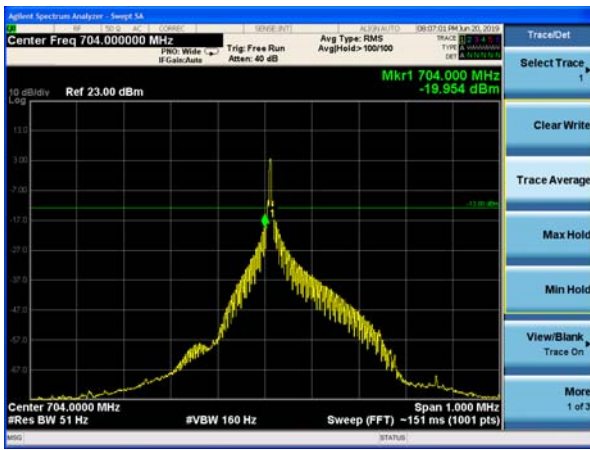

### NB-IOT Band 17 QPSK 3.75kHz 1@47 CH-High

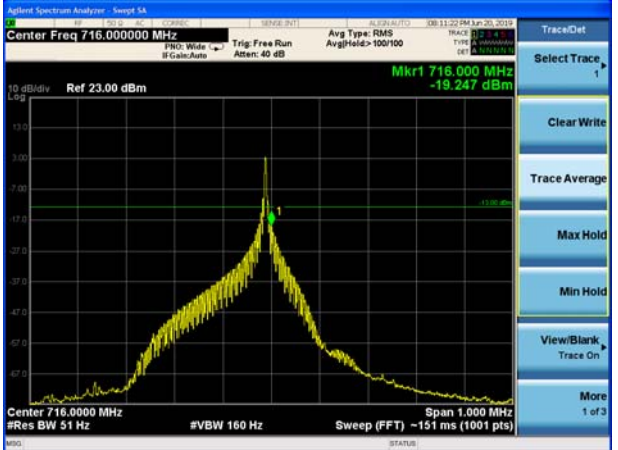



### NB-IOT Band 17 QPSK 15kHz 1@0 CH-Low

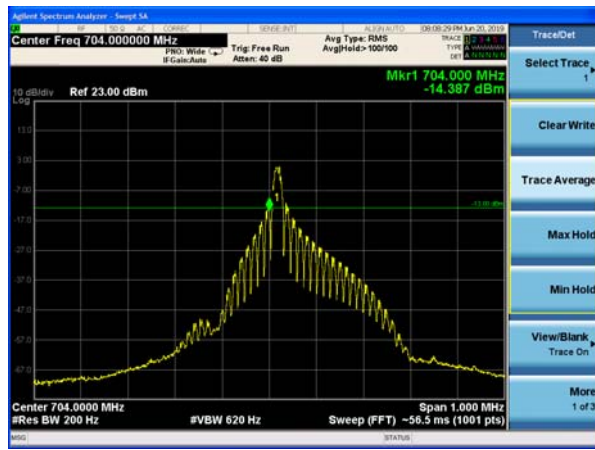

### NB-IOT Band 17 QPSK 15kHz 1@11 CH-High

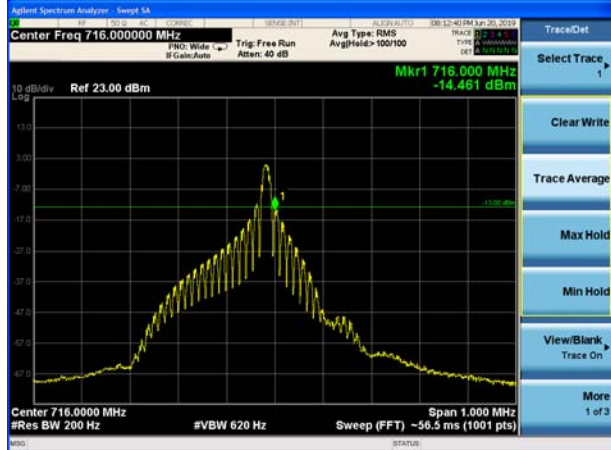

### NB-IOT Band 17 QPSK 15kHz 12@0 CH-Low

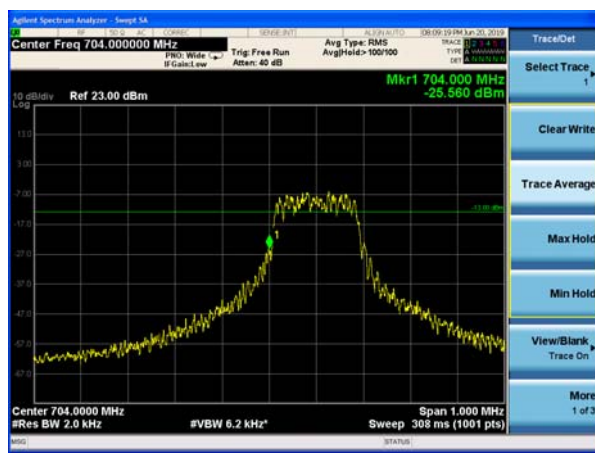

### NB-IOT Band 17 QPSK 15kHz 12@0 CH-High

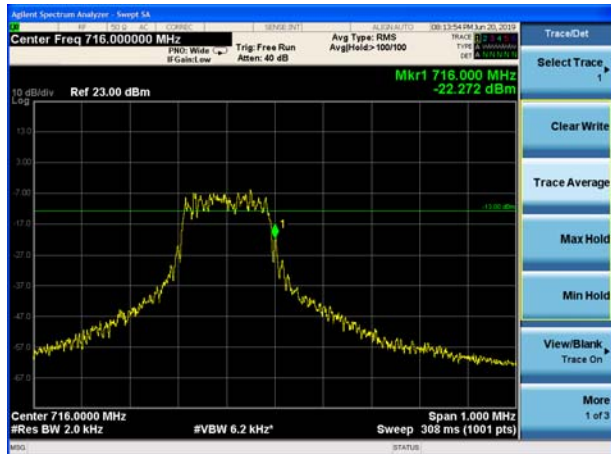



### NB-IOT Band 66 BPSK 3.75kHz 1@0 CH-Low

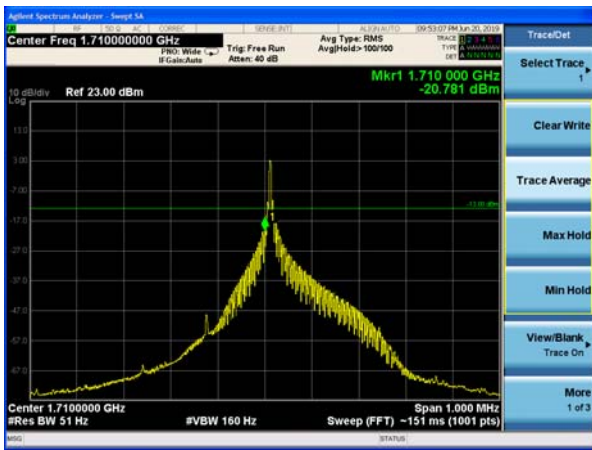

### NB-IOT Band 66 BPSK 3.75kHz 1@47 CH-High

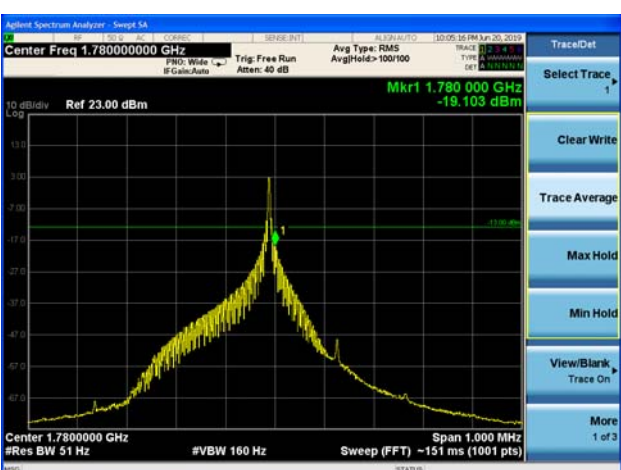

### NB-IOT Band 66 BPSK 15kHz 1@0 CH-Low

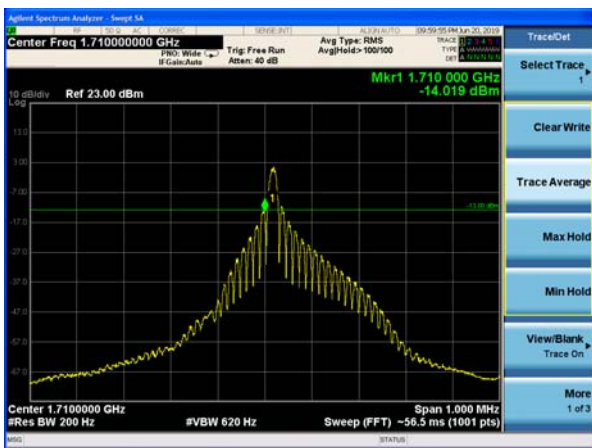

### NB-IOT Band 66 BPSK 15kHz 1@11 CH-High

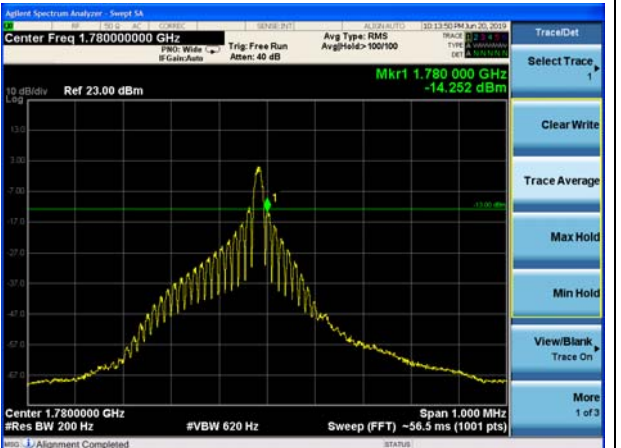

### NB-IOT Band 66 QPSK 3.75kHz 1@0 CH-Low

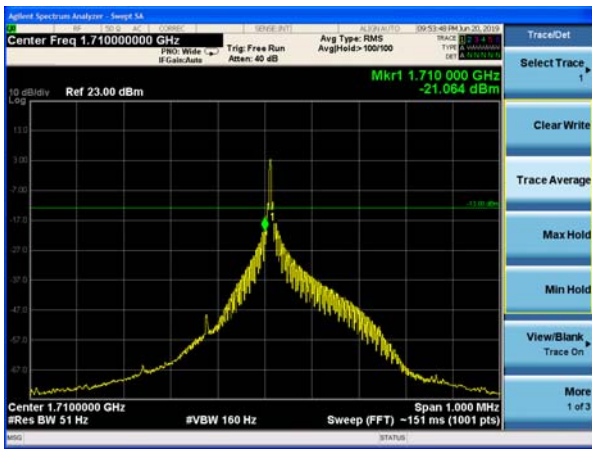

### NB-IOT Band 66 QPSK 3.75kHz 1@47 CH-High

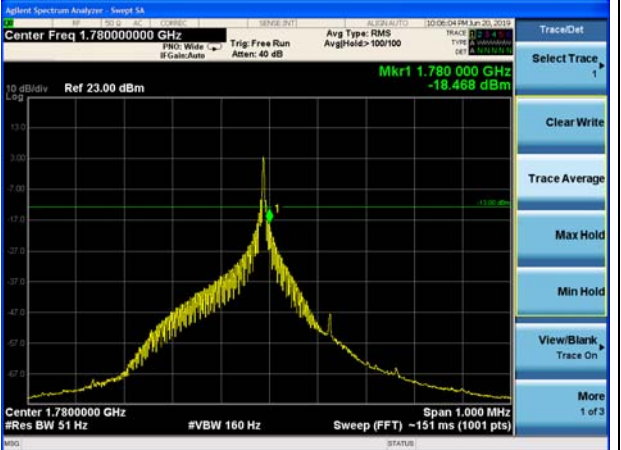



NB-IOT Band 66 QPSK 15kHz 1@0 CH-Low

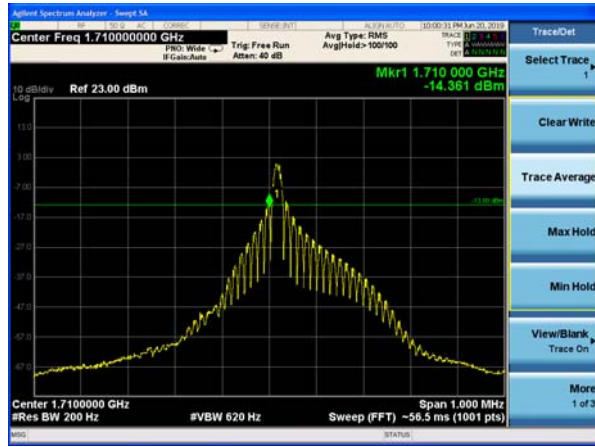

NB-IOT Band 66 QPSK 15kHz 1@11 CH-High

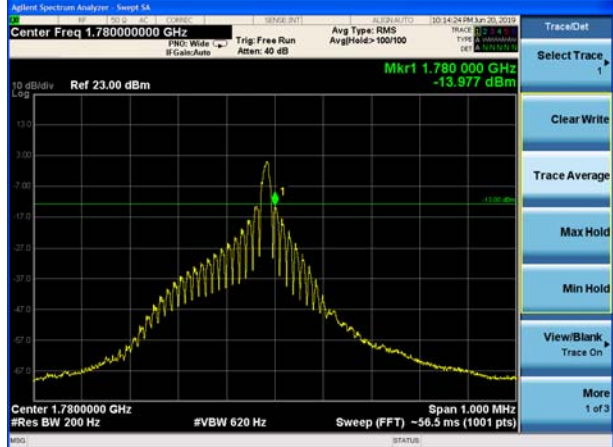

NB-IOT Band 66 QPSK 15kHz 12@0 CH-Low

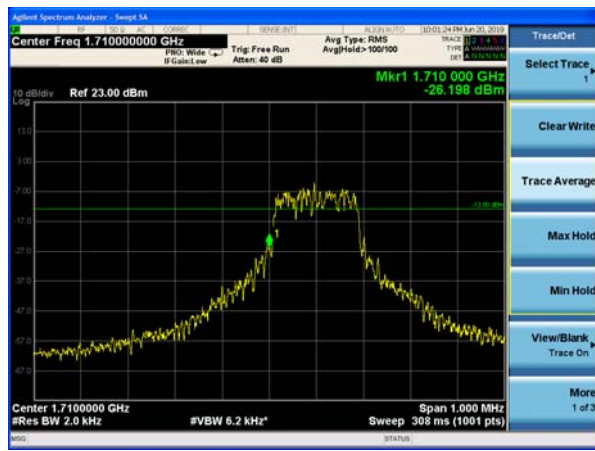

NB-IOT Band 66 QPSK 15kHz 12@0 CH-High

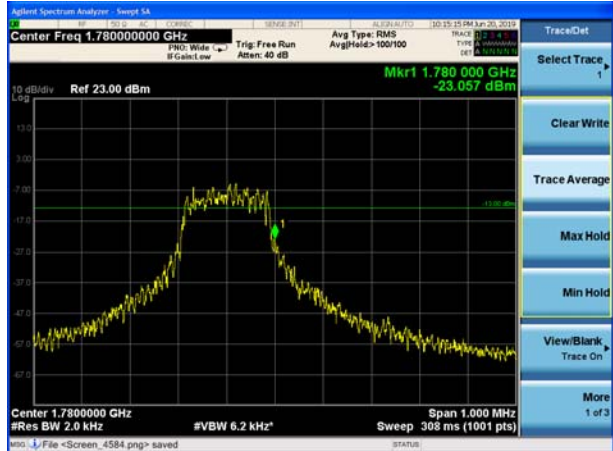





NB-IOT Band 71 BPSK 3.75kHz 1@0 CH-Low

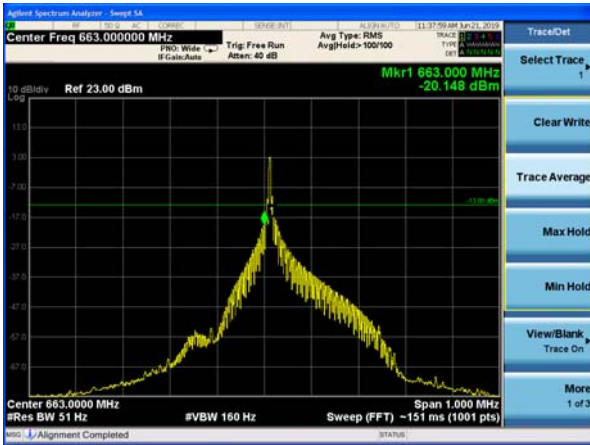

NB-IOT Band 71 BPSK 3.75kHz 1@47 CH-High

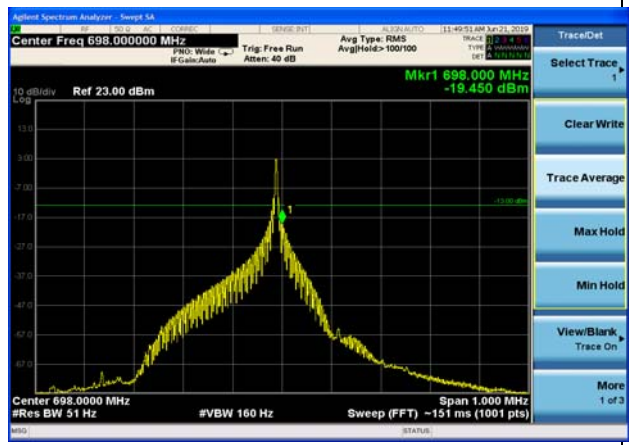

NB-IOT Band 71 BPSK 15kHz 1@0 CH-Low

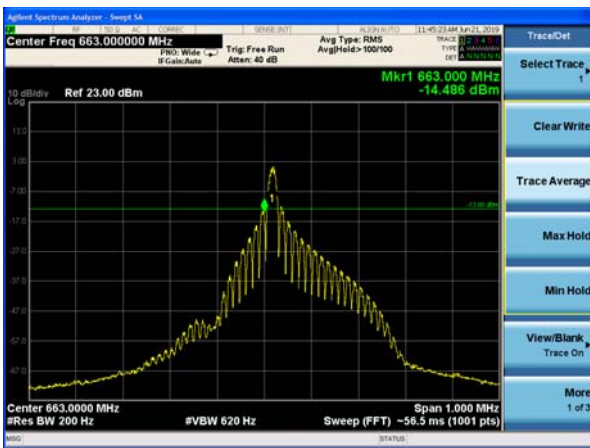

NB-IOT Band 71 BPSK 15kHz 1@11 CH-High

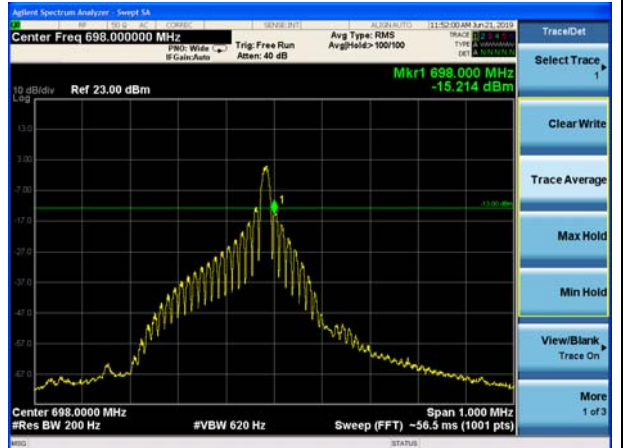

NB-IOT Band 71 QPSK 3.75kHz 1@0 CH-Low

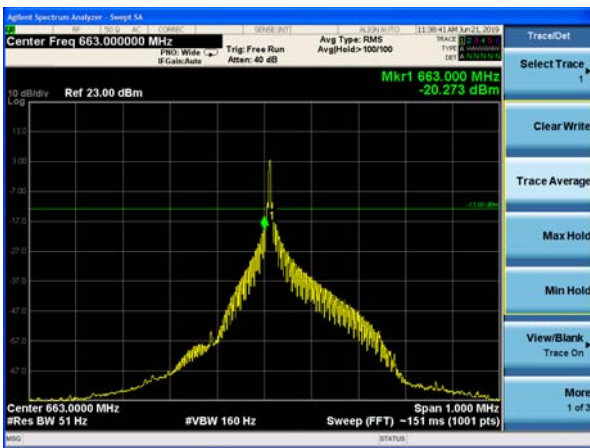

NB-IOT Band 71 QPSK 3.75kHz 1@47 CH-High

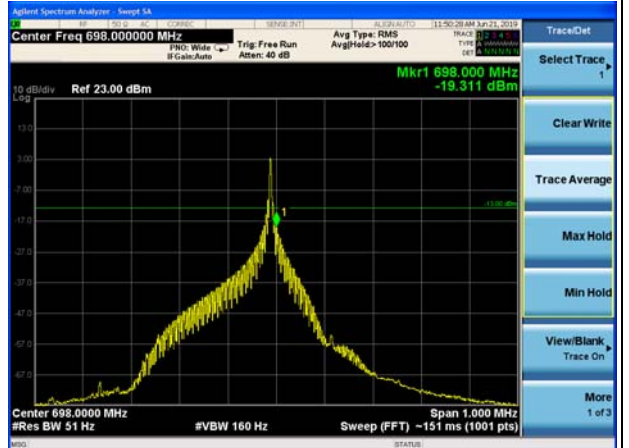



NB-IOT Band 71 QPSK 15kHz 1@0 CH-Low

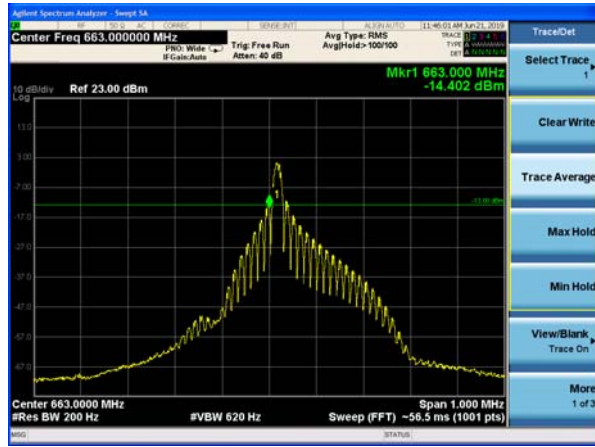

NB-IOT Band 71 QPSK 15kHz 1@11 CH-High

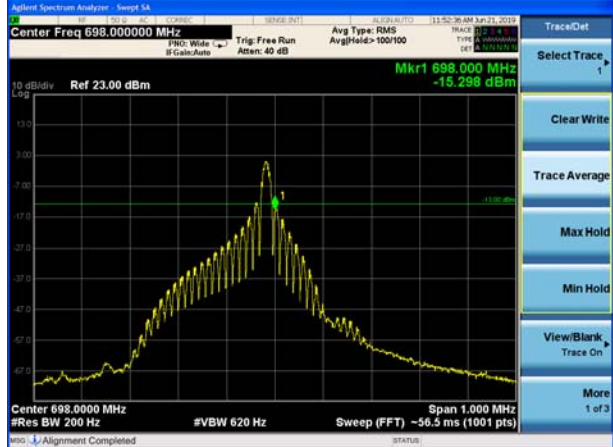

NB-IOT Band 71 QPSK 15kHz 12@0 CH-Low

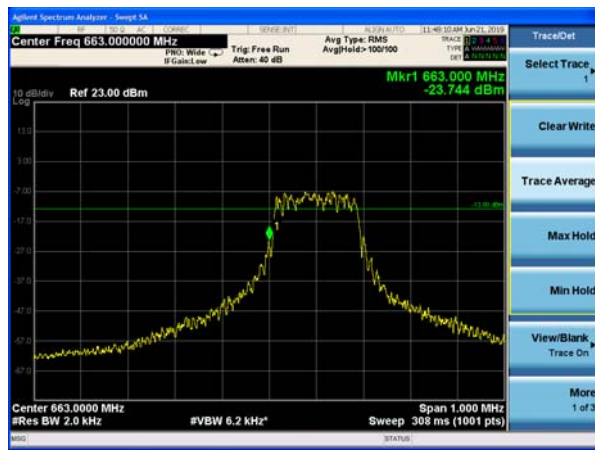

NB-IOT Band 71 QPSK 15kHz 12@0 CH-High

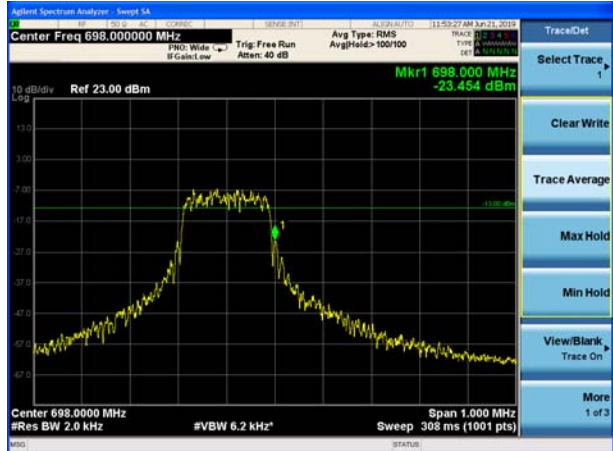



### NB-IOT Band 85 BPSK 3.75kHz 1@0 CH-Low

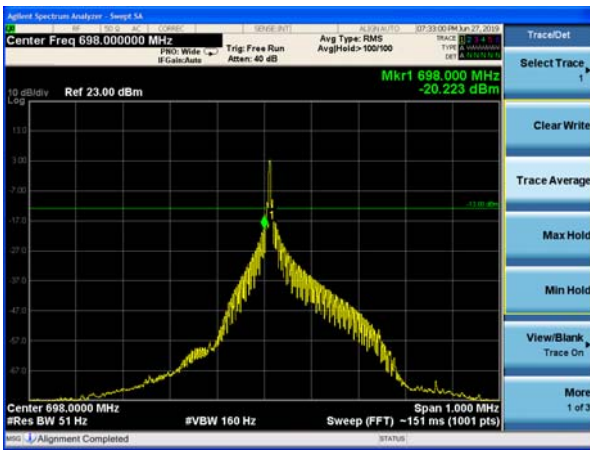

### NB-IOT Band 85 BPSK 3.75kHz 1@47 CH-High

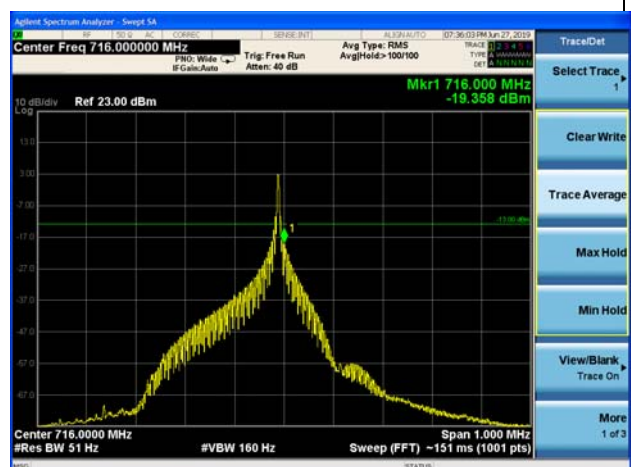

### NB-IOT Band 85 BPSK 15kHz 1@0 CH-Low

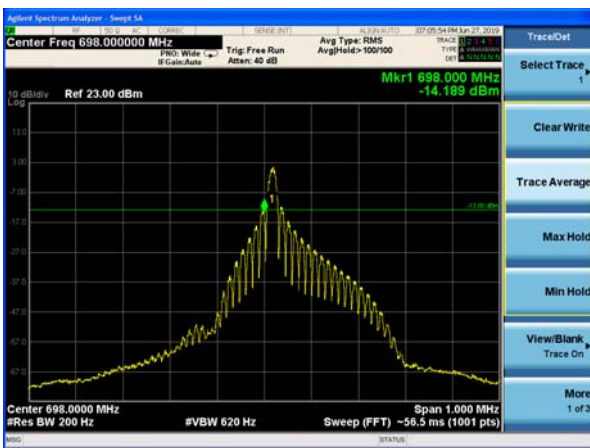

### NB-IOT Band 85 BPSK 15kHz 1@11 CH-High

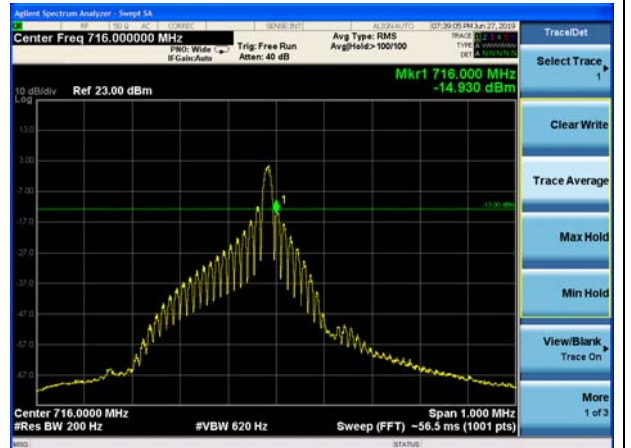

### NB-IOT Band 85 QPSK 3.75kHz 1@0 CH-Low

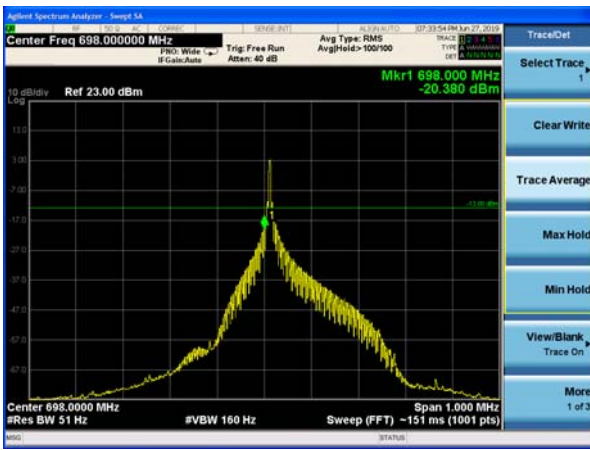

### NB-IOT Band 85 QPSK 3.75kHz 1@47 CH-High

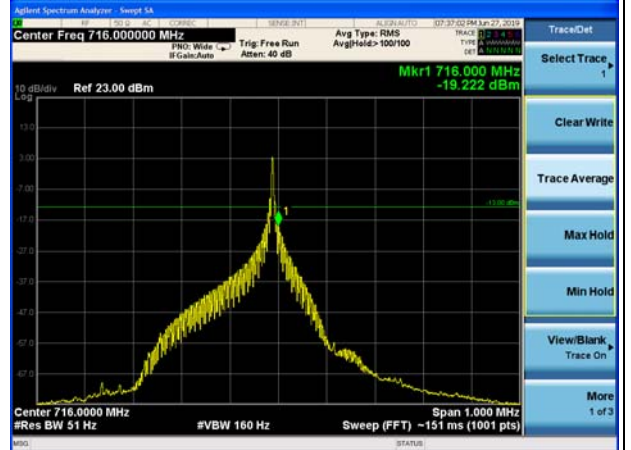



NB-IOT Band 85 QPSK 15kHz 1@0 CH-Low

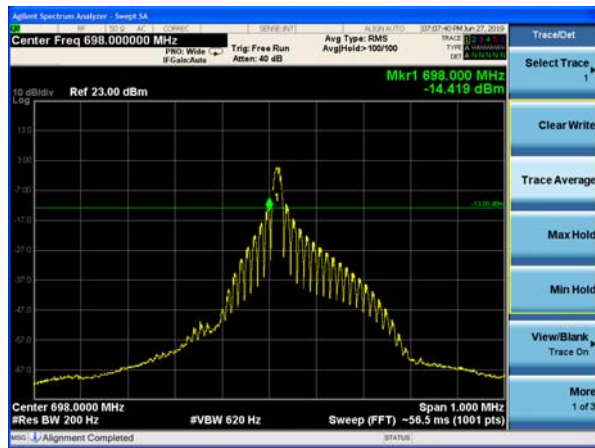

NB-IOT Band 85 QPSK 15kHz 1@11 CH-High

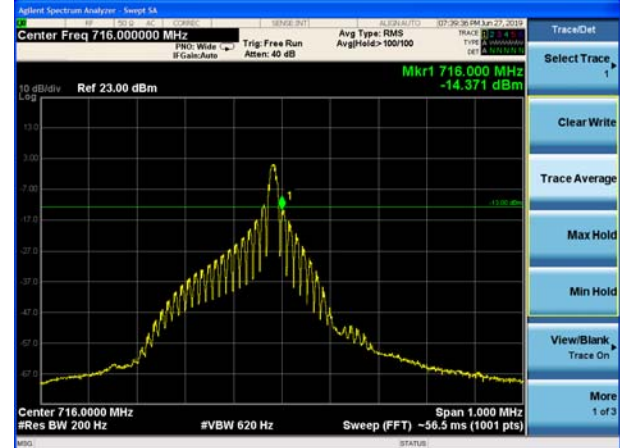

NB-IOT Band 85 QPSK 15kHz 12@0 CH-Low

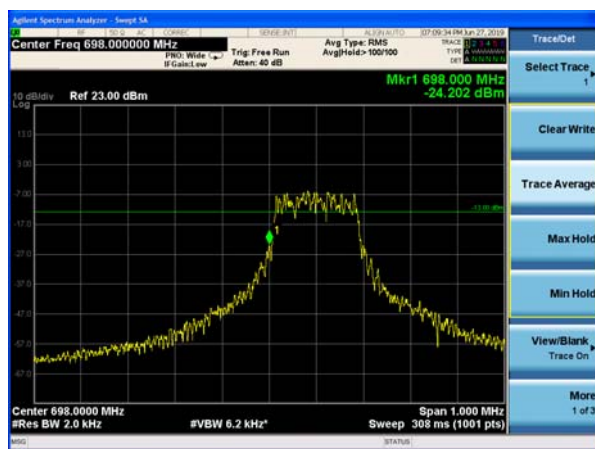

NB-IOT Band 85 QPSK 15kHz 12@0 CH-High

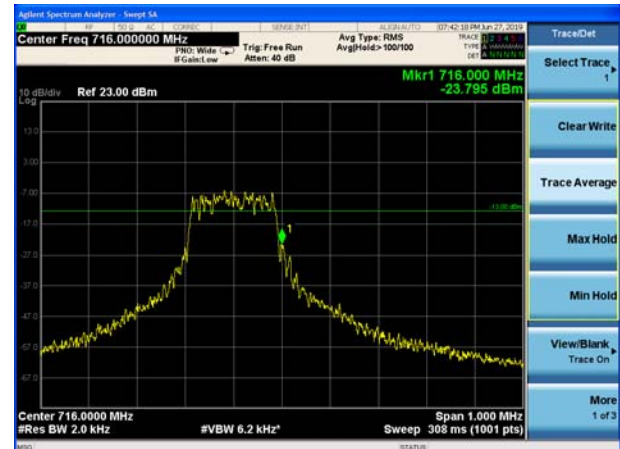

### 5.5 Peak-to-Average Power Ratio (PAPR)

#### Ambient condition

Temperature	Relative humidity	Pressure
23°C ~25°C	45%~50%	101.5kPa

#### Methods of Measurement

Measure the total peak power and record as Ppk. And measure the total average power and record as PAvg. Both the peak and average power levels must be expressed in the same logarithmic units (e.g., dBm). Determine the PAPR from:

$$PAPR (dB) = Ppk (dBm) - PAvg (dBm).$$

#### Test Setup

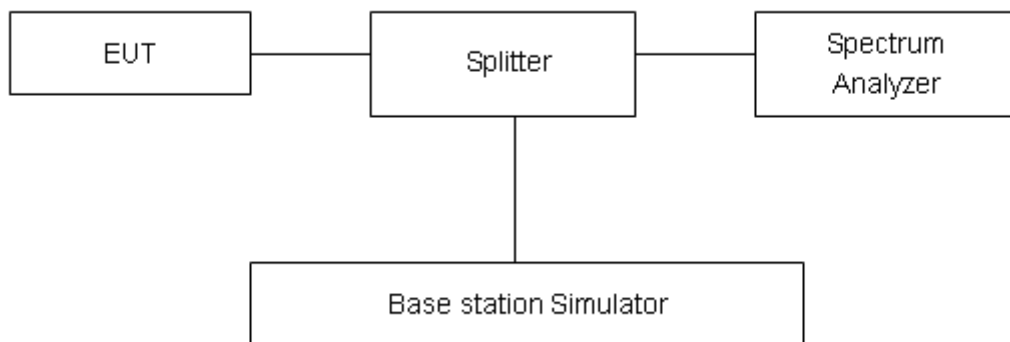

#### Limits

Rule Part 27.50(d)(5) Equipment employed must be authorized in accordance with the provisions of 24.51. Power measurements for transmissions by stations authorized under this section may be made either in accordance with a Commission-approved average power technique or in compliance with paragraph (d)(6) of this section. In measuring transmissions in this band using an average power technique, the peak-to-average ratio (PAR) of the transmission may not exceed 13 dB.

#### Measurement Uncertainty

The assessed measurement uncertainty to ensure 95% confidence level for the normal distribution is with the coverage factor k = 2, U= 0.4 dB.

**Test Results**

Mode	Modulation	Sub-carrier spacing (KHz)	Channel/ Frequency(MHz)	Peak-to-Average Power Ratio (PAPR)		
				Peak(dBm)	Avg(dBm)	PAPR(dB)
Band 4 Standalone	BPSK	3.75	20175/1732.5	23.91	21.43	2.48
	QPSK	3.75	20175/1732.5	24.05	21.44	2.61
	BPSK	15	20175/1732.5	24.00	18.48	5.52
	QPSK	15	20175/1732.5	24.10	18.48	5.62

Mode	Modulation	Sub-carrier spacing (KHz)	Channel/ Frequency(MHz)	Peak-to-Average Power Ratio (PAPR)		
				Peak(dBm)	Avg(dBm)	PAPR(dB)
Band 12 Standalone	BPSK	3.75	23095/707.5	24.18	21.77	2.41
	QPSK	3.75	23095/707.5	24.33	21.67	2.66
	BPSK	15	23095/707.5	24.17	18.69	5.48
	QPSK	15	23095/707.5	24.37	18.72	5.65

Mode	Modulation	Sub-carrier spacing (KHz)	Channel/ Frequency(MHz)	Peak-to-Average Power Ratio (PAPR)		
				Peak(dBm)	Avg(dBm)	PAPR(dB)
Band 13 Standalone	BPSK	3.75	23230/782	24.02	21.57	2.45
	QPSK	3.75	23230/782	24.24	21.58	2.66
	BPSK	15	23230/782	24.12	18.68	5.44
	QPSK	15	23230/782	24.35	18.68	5.67

Mode	Modulation	Sub-carrier spacing (KHz)	Channel/ Frequency(MHz)	Peak-to-Average Power Ratio (PAPR)		
				Peak(dBm)	Avg(dBm)	PAPR(dB)
Band 17 Standalone	BPSK	3.75	23790/710	24.13	21.71	2.42
	QPSK	3.75	23790/710	24.35	21.72	2.63
	BPSK	15	23790/710	24.21	18.75	5.46
	QPSK	15	23790/710	24.43	18.77	5.66

Mode	Modulation	Sub-carrier spacing (KHz)	Channel/ Frequency(MHz)	Peak-to-Average Power Ratio (PAPR)		
				Peak(dBm)	Avg(dBm)	PAPR(dB)
Band 66 Standalone	BPSK	3.75	132322/1745	24.21	21.72	2.49
	QPSK	3.75	132322/1745	24.36	21.73	2.63
	BPSK	15	132322/1745	24.11	18.61	5.50
	QPSK	15	132322/1745	24.24	18.60	5.64



Mode	Modulation	Sub-carrier spacing (KHz)	Channel/ Frequency(MHz)	Peak-to-Average Power Ratio (PAPR)		
				Peak(dBm)	Avg(dBm)	PAPR(dB)
Band 71 Standalone	BPSK	3.75	133297/680.5	24.07	21.68	2.39
	QPSK	3.75	133297/680.5	24.31	21.62	2.69
	BPSK	15	133297/680.5	24.12	18.67	5.45
	QPSK	15	133297/680.5	24.37	18.61	5.76

Mode	Modulation	Sub-carrier spacing (KHz)	Channel/ Frequency(MHz)	Peak-to-Average Power Ratio (PAPR)		
				Peak(dBm)	Avg(dBm)	PAPR(dB)
Band 85 Standalone	BPSK	3.75	134081/705.9	24.11	21.71	2.40
	QPSK	3.75	134081/705.9	24.34	21.69	2.65
	BPSK	15	134081/705.9	24.21	18.76	5.45
	QPSK	15	134081/705.9	24.45	18.75	5.70

## 5.6 Frequency Stability

### Ambient condition

Temperature	Relative humidity	Pressure
23°C ~25°C	45%~50%	101.5kPa

### Method of Measurement

#### Frequency Stability (Temperature Variation)

The temperature inside the climate chamber is varied from -40°C to +85°C in 10°C step size.

(1) With all power removed, the temperature was decreased to -10°C and permitted to stabilize for three hours.

(2) Measure the carrier frequency with the test equipment in a “call mode”. These measurements should be made within 1 minute of powering up the mobile station, to prevent significant self warming.

(3) Repeat the above measurements at 10°C increments from -40°C to +85°C. Allow at least 1.5 hours at each temperature, un-powered, before making measurements.

#### Frequency Stability (Voltage Variation)

The frequency stability shall be measured with variation of primary supply voltage as follows:

(1) Vary primary supply voltage from 85 to 115 percent of the nominal value for other than hand carried battery equipment.

(2) For hand carried, battery powered equipment, reduce primary supply voltage to the battery-operating end point which shall be specified by the manufacturer.

This transceiver is specified to operate with an input voltage of between 2.1 V and 3.6V, with a nominal voltage of 3.3V.

### Test setup

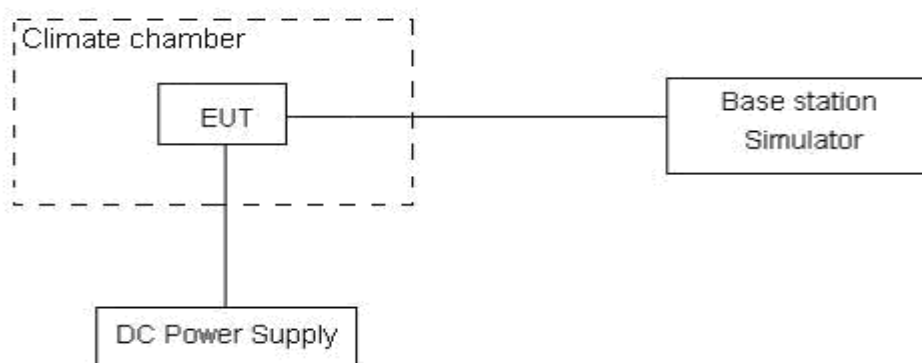

### Limits

The frequency stability shall be sufficient to ensure that the fundamental emissions stay within the authorized bands of operation.

### Measurement Uncertainty

The assessed measurement uncertainty to ensure 99.75% confidence level for the normal distribution is with the coverage factor  $k = 3, U = 0.01\text{ppm}$ .





## Test Result

NB-IOT Band 4						
Condition		Freq.Error (Hz)	Freq.Error (Hz)	Frequency Stability (ppm)	Frequency Stability (ppm)	Verdict
BANDWIDTH	3.75	BPSK	QPSK	BPSK	QPSK	
Temperature	Voltage					
Normal (25°C)	Normal	8.79	5.40	0.00467	0.00287	PASS
Extreme (85°C)		12.90	7.88	0.00686	0.00419	PASS
Extreme (80°C)		10.75	16.59	0.00572	0.00883	PASS
Extreme (70°C)		17.07	7.14	0.00908	0.00380	PASS
Extreme (60°C)		9.25	15.17	0.00492	0.00807	PASS
Extreme (50°C)		12.26	11.28	0.00652	0.00600	PASS
Extreme (40°C)		15.44	4.45	0.00821	0.00236	PASS
Extreme (30°C)		13.06	8.24	0.00695	0.00438	PASS
Extreme (20°C)		8.29	13.45	0.00441	0.00715	PASS
Extreme (10°C)		11.30	4.79	0.00601	0.00255	PASS
Extreme (0°C)		15.49	3.95	0.00824	0.00210	PASS
Extreme (-10°C)		5.49	11.50	0.00292	0.00612	PASS
Extreme (-20°C)		4.80	10.34	0.00255	0.00550	PASS
Extreme (-30°C)		13.41	8.88	0.00713	0.00473	PASS
Extreme (-40°C)		4.75	2.52	0.00253	0.00134	PASS
25°C	LV	4.34	16.58	0.00231	0.00882	PASS
	HV	14.33	4.93	0.00762	0.00262	PASS
Condition		Freq.Error (Hz)	Freq.Error (Hz)	Frequency Stability (ppm)	Frequency Stability (ppm)	Verdict
BANDWIDTH	15	BPSK	QPSK	BPSK	QPSK	
Temperature	Voltage					
Normal (25°C)	Normal	5.47	9.54	0.00291	0.00508	PASS
Extreme (85°C)		14.65	11.48	0.00779	0.00611	PASS
Extreme (80°C)		15.98	2.04	0.00850	0.00109	PASS
Extreme (70°C)		17.17	14.58	0.00914	0.00775	PASS
Extreme (60°C)		5.87	10.25	0.00312	0.00545	PASS
Extreme (50°C)		3.36	9.90	0.00179	0.00527	PASS
Extreme (40°C)		11.77	3.55	0.00626	0.00189	PASS
Extreme (30°C)		14.18	5.03	0.00754	0.00268	PASS
Extreme (20°C)		2.43	4.43	0.00129	0.00235	PASS
Extreme (10°C)		12.21	11.51	0.00649	0.00612	PASS
Extreme (0°C)		5.23	1.08	0.00278	0.00058	PASS
Extreme (-10°C)		17.60	13.23	0.00936	0.00704	PASS
Extreme (-20°C)		1.53	5.71	0.00082	0.00304	PASS
Extreme (-30°C)		10.46	9.09	0.00557	0.00484	PASS
Extreme (-40°C)		13.90	11.09	0.00739	0.00590	PASS
25°C	LV	6.46	7.48	0.00343	0.00398	PASS



	HV	11.45	2.03	0.00609	0.00108	PASS
--	----	-------	------	---------	---------	------

NB-IOT Band 12						
Condition		Freq.Error (Hz)	Freq.Error (Hz)	Frequency Stability (ppm)	Frequency Stability (ppm)	Verdict
BANDWIDTH	3.75					
Temperature	Voltage	BPSK	QPSK	BPSK	QPSK	
Normal (25°C)	Normal	5.66	5.39	0.00301	0.00287	PASS
Extreme (85°C)		10.34	14.67	0.00550	0.00780	PASS
Extreme (80°C)		6.15	6.18	0.00327	0.00329	PASS
Extreme (70°C)		7.34	7.92	0.00391	0.00422	PASS
Extreme (60°C)		15.66	2.11	0.00833	0.00112	PASS
Extreme (50°C)		13.61	1.76	0.00724	0.00094	PASS
Extreme (40°C)		1.17	17.65	0.00062	0.00939	PASS
Extreme (30°C)		4.24	16.62	0.00225	0.00884	PASS
Extreme (20°C)		4.32	14.18	0.00230	0.00754	PASS
Extreme (10°C)		11.33	16.49	0.00602	0.00877	PASS
Extreme (0°C)		9.60	3.44	0.00511	0.00183	PASS
Extreme (-10°C)		2.31	14.72	0.00123	0.00783	PASS
Extreme (-20°C)		5.62	16.60	0.00299	0.00883	PASS
Extreme (-30°C)		7.65	16.87	0.00407	0.00897	PASS
Extreme (-40°C)		14.75	15.43	0.00785	0.00821	PASS
25°C		LV	16.02	15.48	0.00852	0.00823
	HV	6.28	6.09	0.00334	0.00324	PASS
Condition		Freq.Error (Hz)	Freq.Error (Hz)	Frequency Stability (ppm)	Frequency Stability (ppm)	Verdict
BANDWIDTH	15					
Temperature	Voltage	BPSK	QPSK	BPSK	QPSK	
Normal (25°C)	Normal	6.53	17.73	0.00347	0.00943	PASS
Extreme (85°C)		4.79	10.90	0.00255	0.00580	PASS
Extreme (80°C)		4.23	7.93	0.00225	0.00422	PASS
Extreme (70°C)		15.87	4.02	0.00844	0.00214	PASS
Extreme (60°C)		3.75	15.53	0.00199	0.00826	PASS
Extreme (50°C)		10.63	16.79	0.00565	0.00893	PASS
Extreme (40°C)		9.52	4.06	0.00506	0.00216	PASS
Extreme (30°C)		7.65	13.15	0.00407	0.00700	PASS
Extreme (20°C)		17.55	5.10	0.00934	0.00271	PASS
Extreme (10°C)		6.90	7.69	0.00367	0.00409	PASS
Extreme (0°C)		13.69	14.76	0.00728	0.00785	PASS
Extreme (-10°C)		2.34	1.17	0.00124	0.00062	PASS
Extreme (-20°C)		1.85	9.48	0.00099	0.00504	PASS
Extreme (-30°C)		9.32	17.42	0.00496	0.00927	PASS
Extreme (-40°C)		1.50	10.45	0.00080	0.00556	PASS



25°C	LV	9.50	5.73	0.00505	0.00305	PASS
	HV	14.45	2.16	0.00768	0.00115	PASS

NB-IOT Band 13						
Condition		Freq.Error (Hz)	Freq.Error (Hz)	Frequency Stability (ppm)	Frequency Stability (ppm)	Verdict
BANDWIDTH	3.75	BPSK	QPSK	BPSK	QPSK	
Temperature	Voltage					
Normal (25°C)	Normal	6.76	15.69	0.00360	0.00835	PASS
Extreme (85°C)		17.62	16.35	0.00937	0.00870	PASS
Extreme (80°C)		10.40	3.96	0.00553	0.00210	PASS
Extreme (70°C)		8.73	8.22	0.00464	0.00437	PASS
Extreme (60°C)		15.66	1.19	0.00833	0.00063	PASS
Extreme (50°C)		10.75	8.40	0.00572	0.00447	PASS
Extreme (40°C)		8.65	9.28	0.00460	0.00494	PASS
Extreme (30°C)		2.06	7.15	0.00110	0.00381	PASS
Extreme (20°C)		1.13	17.35	0.00060	0.00923	PASS
Extreme (10°C)		14.07	10.69	0.00748	0.00569	PASS
Extreme (0°C)		15.99	10.88	0.00850	0.00579	PASS
Extreme (-10°C)		15.81	7.85	0.00841	0.00417	PASS
Extreme (-20°C)		3.24	6.35	0.00172	0.00338	PASS
Extreme (-30°C)		12.91	3.46	0.00687	0.00184	PASS
Extreme (-40°C)		13.03	5.15	0.00693	0.00274	PASS
25°C	LV	4.24	10.76	0.00225	0.00572	PASS
	HV	7.06	12.35	0.00375	0.00657	PASS
Condition		Freq.Error (Hz)	Freq.Error (Hz)	Frequency Stability (ppm)	Frequency Stability (ppm)	Verdict
BANDWIDTH	15	BPSK	QPSK	BPSK	QPSK	
Temperature	Voltage					
Normal (25°C)	Normal	6.32	13.49	0.00336	0.00717	PASS
Extreme (85°C)		3.08	13.90	0.00164	0.00739	PASS
Extreme (80°C)		5.81	15.11	0.00309	0.00804	PASS
Extreme (70°C)		15.43	5.24	0.00821	0.00279	PASS
Extreme (60°C)		15.26	17.77	0.00812	0.00945	PASS
Extreme (50°C)		1.85	9.77	0.00098	0.00520	PASS
Extreme (40°C)		7.29	10.14	0.00388	0.00539	PASS
Extreme (30°C)		5.86	13.74	0.00311	0.00731	PASS
Extreme (20°C)		16.10	4.51	0.00857	0.00240	PASS
Extreme (10°C)		4.62	11.85	0.00246	0.00630	PASS
Extreme (0°C)		6.72	15.08	0.00357	0.00802	PASS
Extreme (-10°C)		9.29	14.78	0.00494	0.00786	PASS
Extreme (-20°C)		8.34	16.57	0.00444	0.00881	PASS
Extreme (-30°C)		3.23	2.03	0.00172	0.00108	PASS



Extreme (-40°C)		1.19	5.88	0.00063	0.00313	PASS
25°C	LV	3.01	10.39	0.00160	0.00553	PASS
	HV	17.94	14.90	0.00954	0.00792	PASS

NB-IOT Band 17						
Condition		Freq.Error (Hz)	Freq.Error (Hz)	Frequency Stability (ppm)	Frequency Stability (ppm)	Verdict
BANDWIDTH	3.75					
Temperature	Voltage	BPSK	QPSK	BPSK	QPSK	
Normal (25°C)	Normal	8.61	3.84	0.00458	0.00204	PASS
Extreme (85°C)		7.79	9.38	0.00414	0.00499	PASS
Extreme (80°C)		10.52	10.66	0.00559	0.00567	PASS
Extreme (70°C)		17.32	5.89	0.00921	0.00313	PASS
Extreme (60°C)		11.47	8.40	0.00610	0.00447	PASS
Extreme (50°C)		14.12	15.39	0.00751	0.00819	PASS
Extreme (40°C)		5.92	2.56	0.00315	0.00136	PASS
Extreme (30°C)		14.09	2.04	0.00750	0.00108	PASS
Extreme (20°C)		3.52	8.72	0.00187	0.00464	PASS
Extreme (10°C)		10.74	10.41	0.00571	0.00554	PASS
Extreme (0°C)		2.33	17.10	0.00124	0.00909	PASS
Extreme (-10°C)		5.37	3.76	0.00286	0.00200	PASS
Extreme (-20°C)		3.04	7.79	0.00162	0.00414	PASS
Extreme (-30°C)		12.26	1.76	0.00652	0.00094	PASS
Extreme (-40°C)		10.30	5.92	0.00548	0.00315	PASS
25°C	LV	3.77	2.25	0.00201	0.00120	PASS
	HV	14.99	5.41	0.00797	0.00288	PASS

NB-IOT Band 17						
Condition		Freq.Error (Hz)	Freq.Error (Hz)	Frequency Stability (ppm)	Frequency Stability (ppm)	Verdict
BANDWIDTH	15					
Temperature	Voltage	BPSK	QPSK	BPSK	QPSK	
Normal (25°C)	Normal	9.85	10.87	0.00524	0.00578	PASS
Extreme (85°C)		16.49	8.30	0.00877	0.00442	PASS
Extreme (80°C)		6.35	6.47	0.00338	0.00344	PASS
Extreme (70°C)		2.17	1.44	0.00116	0.00076	PASS
Extreme (60°C)		6.94	13.95	0.00369	0.00742	PASS
Extreme (50°C)		13.66	7.35	0.00726	0.00391	PASS
Extreme (40°C)		2.04	12.83	0.00109	0.00682	PASS
Extreme (30°C)		14.95	4.18	0.00795	0.00222	PASS
Extreme (20°C)		12.50	16.56	0.00665	0.00881	PASS
Extreme (10°C)		3.67	7.50	0.00195	0.00399	PASS
Extreme (0°C)		17.20	16.08	0.00915	0.00855	PASS
Extreme (-10°C)		16.63	6.28	0.00885	0.00334	PASS



Extreme (-20°C)		3.20	16.25	0.00170	0.00864	PASS
Extreme (-30°C)		13.29	7.34	0.00707	0.00390	PASS
Extreme (-40°C)		8.35	12.54	0.00444	0.00667	PASS
25°C	LV	11.73	9.27	0.00624	0.00493	PASS
	HV	11.52	4.24	0.00613	0.00226	PASS

NB-IOT Band 66						
Condition		Freq.Error (Hz)	Freq.Error (Hz)	Frequency Stability (ppm)	Frequency Stability (ppm)	Verdict
BANDWIDTH	3.75					
Temperature	Voltage	BPSK	QPSK	BPSK	QPSK	
Normal (25°C)	Normal	16.62	14.58	0.00884	0.00775	PASS
Extreme (85°C)		4.31	8.13	0.00229	0.00432	PASS
Extreme (80°C)		1.60	16.57	0.00085	0.00882	PASS
Extreme (70°C)		4.30	13.84	0.00229	0.00736	PASS
Extreme (60°C)		5.59	12.67	0.00297	0.00674	PASS
Extreme (50°C)		6.66	1.71	0.00354	0.00091	PASS
Extreme (40°C)		10.89	17.95	0.00579	0.00955	PASS
Extreme (30°C)		7.42	11.34	0.00395	0.00603	PASS
Extreme (20°C)		5.95	11.19	0.00317	0.00595	PASS
Extreme (10°C)		9.11	7.50	0.00485	0.00399	PASS
Extreme (0°C)		9.08	7.20	0.00483	0.00383	PASS
Extreme (-10°C)		16.55	9.60	0.00880	0.00511	PASS
Extreme (-20°C)		9.39	2.03	0.00499	0.00108	PASS
Extreme (-30°C)		8.30	9.86	0.00442	0.00525	PASS
Extreme (-40°C)		6.73	8.72	0.00358	0.00464	PASS
25°C	LV	1.10	6.97	0.00058	0.00371	PASS
	HV	16.63	11.86	0.00885	0.00631	PASS
Condition		Freq.Error (Hz)	Freq.Error (Hz)	Frequency Stability (ppm)	Frequency Stability (ppm)	Verdict
BANDWIDTH	15					
Temperature	Voltage	BPSK	QPSK	BPSK	QPSK	
Normal (25°C)	Normal	10.15	6.09	0.00540	0.00324	PASS
Extreme (85°C)		7.18	9.34	0.00382	0.00497	PASS
Extreme (80°C)		16.49	7.90	0.00877	0.00420	PASS
Extreme (70°C)		6.16	8.38	0.00328	0.00446	PASS
Extreme (60°C)		6.55	12.84	0.00348	0.00683	PASS
Extreme (50°C)		3.92	1.38	0.00208	0.00073	PASS
Extreme (40°C)		9.20	2.11	0.00489	0.00112	PASS
Extreme (30°C)		11.21	14.43	0.00596	0.00767	PASS
Extreme (20°C)		14.60	4.20	0.00777	0.00223	PASS
Extreme (10°C)		4.26	4.04	0.00226	0.00215	PASS



Extreme (0°C)		9.33	3.66	0.00496	0.00195	PASS
Extreme (-10°C)		9.64	12.67	0.00513	0.00674	PASS
Extreme (-20°C)		7.41	10.75	0.00394	0.00572	PASS
Extreme (-30°C)		13.53	10.16	0.00720	0.00540	PASS
Extreme (-40°C)		11.49	17.89	0.00611	0.00952	PASS
25°C	LV	13.32	15.74	0.00708	0.00837	PASS
	HV	11.52	4.81	0.00613	0.00256	PASS

NB-IOT Band 71							
Condition		Freq.Error (Hz)	Freq.Error (Hz)	Frequency Stability (ppm)	Frequency Stability (ppm)	Verdict	
BANDWIDTH	3.75	BPSK	QPSK	BPSK	QPSK		
Temperature	Voltage						
Normal	Normal	Normal (25°C)	3.62	2.59	0.00192	0.00138	PASS
		Extreme (85°C)	8.58	2.64	0.00456	0.00140	PASS
		Extreme (80°C)	13.78	8.22	0.00733	0.00437	PASS
		Extreme (70°C)	11.58	10.89	0.00616	0.00579	PASS
		Extreme (60°C)	12.71	12.53	0.00676	0.00666	PASS
		Extreme (50°C)	10.95	7.01	0.00582	0.00373	PASS
		Extreme (40°C)	3.04	11.58	0.00162	0.00616	PASS
		Extreme (30°C)	14.57	3.62	0.00775	0.00192	PASS
		Extreme (20°C)	9.30	13.81	0.00495	0.00735	PASS
		Extreme (10°C)	1.72	17.63	0.00092	0.00938	PASS
		Extreme (0°C)	9.74	11.76	0.00518	0.00626	PASS
		Extreme (-10°C)	9.43	15.93	0.00502	0.00847	PASS
		Extreme (-20°C)	11.71	5.56	0.00623	0.00296	PASS
		Extreme (-30°C)	2.13	15.41	0.00113	0.00820	PASS
		Extreme (-40°C)	11.50	6.24	0.00612	0.00332	PASS
25°C	LV	5.66	1.89	0.00301	0.00101	PASS	
	HV	11.89	16.86	0.00633	0.00897	PASS	
Condition		Freq.Error (Hz)	Freq.Error (Hz)	Frequency Stability (ppm)	Frequency Stability (ppm)	Verdict	
BANDWIDTH	15	BPSK	QPSK	BPSK	QPSK		
Temperature	Voltage						
Normal	Normal	Normal (25°C)	4.08	7.43	0.00217	0.00395	PASS
		Extreme (85°C)	10.41	15.57	0.00554	0.00828	PASS
		Extreme (80°C)	15.27	5.95	0.00812	0.00316	PASS
		Extreme (70°C)	6.95	7.43	0.00370	0.00395	PASS
		Extreme (60°C)	14.14	5.79	0.00752	0.00308	PASS
		Extreme (50°C)	1.35	2.07	0.00072	0.00110	PASS
		Extreme (40°C)	13.72	17.71	0.00730	0.00942	PASS
		Extreme (30°C)	6.34	7.85	0.00337	0.00417	PASS



Extreme (20°C)		6.67	13.04	0.00355	0.00693	PASS
Extreme (10°C)		13.72	17.50	0.00730	0.00931	PASS
Extreme (0°C)		8.42	7.26	0.00448	0.00386	PASS
Extreme (-10°C)		10.84	10.71	0.00577	0.00570	PASS
Extreme (-20°C)		4.12	12.15	0.00219	0.00646	PASS
Extreme (-30°C)		4.32	6.28	0.00230	0.00334	PASS
Extreme (-40°C)		11.62	2.50	0.00618	0.00133	PASS
25°C	LV	11.88	4.64	0.00632	0.00247	PASS
	HV	5.74	9.09	0.00305	0.00483	PASS

NB-IOT Band 85						
Condition		Freq.Error (Hz)	Freq.Error (Hz)	Frequency Stability (ppm)	Frequency Stability (ppm)	Verdict
BANDWIDTH	3.75					
Temperature	Voltage	BPSK	QPSK	BPSK	QPSK	
Normal (25°C)	Normal	17.26	4.37	0.00918	0.00233	PASS
Extreme (85°C)		17.60	16.38	0.00936	0.00871	PASS
Extreme (80°C)		7.20	12.93	0.00383	0.00688	PASS
Extreme (70°C)		5.59	2.51	0.00297	0.00133	PASS
Extreme (60°C)		13.93	16.28	0.00741	0.00866	PASS
Extreme (50°C)		4.28	11.21	0.00228	0.00596	PASS
Extreme (40°C)		4.63	11.08	0.00246	0.00590	PASS
Extreme (30°C)		12.95	3.02	0.00689	0.00160	PASS
Extreme (20°C)		14.77	6.79	0.00786	0.00361	PASS
Extreme (10°C)		4.48	15.27	0.00238	0.00812	PASS
Extreme (0°C)		1.41	8.81	0.00075	0.00469	PASS
Extreme (-10°C)		13.77	5.66	0.00732	0.00301	PASS
Extreme (-20°C)		6.12	15.23	0.00326	0.00810	PASS
Extreme (-30°C)		9.78	8.50	0.00520	0.00452	PASS
Extreme (-40°C)		8.73	14.14	0.00464	0.00752	PASS
25°C	LV	17.79	17.19	0.00946	0.00914	PASS
	HV	10.49	13.31	0.00558	0.00708	PASS
Condition		Freq.Error (Hz)	Freq.Error (Hz)	Frequency Stability (ppm)	Frequency Stability (ppm)	Verdict
BANDWIDTH	15					
Temperature	Voltage	BPSK	QPSK	BPSK	QPSK	
Normal (25°C)	Normal	17.72	6.39	0.00942	0.00340	PASS
Extreme (85°C)		3.01	17.50	0.00160	0.00931	PASS
Extreme (80°C)		5.54	12.59	0.00294	0.00670	PASS
Extreme (70°C)		9.92	2.48	0.00527	0.00132	PASS
Extreme (60°C)		1.64	3.28	0.00087	0.00174	PASS
Extreme (50°C)		15.00	12.30	0.00798	0.00654	PASS
Extreme (40°C)		4.42	2.79	0.00235	0.00148	PASS



Extreme (30°C)		12.68	13.80	0.00674	0.00734	PASS
Extreme (20°C)		15.57	17.68	0.00828	0.00941	PASS
Extreme (10°C)		10.98	2.39	0.00584	0.00127	PASS
Extreme (0°C)		5.66	6.34	0.00301	0.00337	PASS
Extreme (-10°C)		15.45	7.84	0.00822	0.00417	PASS
Extreme (-20°C)		16.80	17.22	0.00894	0.00916	PASS
Extreme (-30°C)		10.30	3.51	0.00548	0.00187	PASS
Extreme (-40°C)		13.42	9.31	0.00714	0.00495	PASS
25°C	LV	16.32	10.26	0.00868	0.00546	PASS
	HV	9.82	6.04	0.00522	0.00321	PASS



## 5.7 Spurious Emissions at Antenna Terminals

### Ambient condition

Temperature	Relative humidity	Pressure
23°C ~25°C	45%~50%	101.5kPa

### Method of Measurement

The EUT was connected to Spectrum Analyzer and Base Station Simulator via power Splitter. The measurement is carried out using a spectrum analyzer. The spectrum analyzer scans from 9kHz to the 10th harmonic of the carrier. The peak detector is used.

RBW is set to 100kHz, VBW is set to 300kHz for 30MHz~1GHz

RBW is set to 1MHz, VBW is set to 3MHz for above 1GHz, Sweep is set to ATUO.

Of those disturbances below (limit – 20 dB), the mark is not required for the EUT.

The modulation mode and RB allocation refer to section 5.1, using the maximum output power configuration.

### Test setup

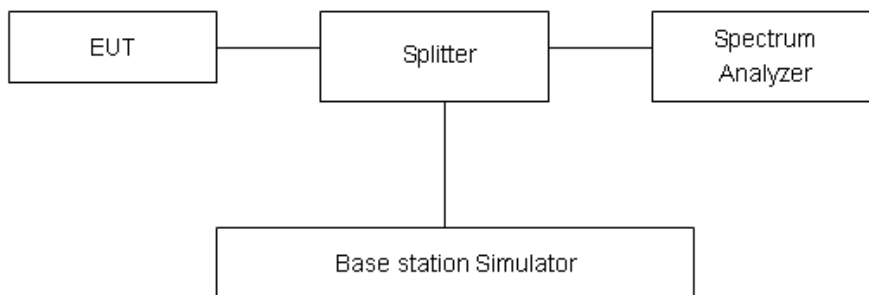

### Limits

Rule Part 27.53(h) specifies that “for operations in the 1695-1710 MHz, 1710-1755 MHz, 1755-1780 MHz, 1915-1920 MHz, 1995-2000 MHz, 2000-2020 MHz, 2110-2155 MHz, 2155-2180 MHz, and 2180-2200 bands, the power of any emission outside a licensee's frequency block shall be attenuated below the transmitter power (P) in watts by at least  $43 + 10 \log_{10}(P)$  dB..”

Rule Part 27.53 (g) For operations in the 600 MHz band and the 698-746 MHz band, the power of any emission outside a licensee's frequency band(s) of operation shall be attenuated below the transmitter power (P) within the licensed band(s) of operation, measured in watts, by at least  $43 + 10 \log(P)$  dB. Compliance with this provision is based on the use of measurement instrumentation employing a resolution bandwidth of 100 kilohertz or greater. However, in the 100 kilohertz bands immediately outside and adjacent to a licensee's frequency block, a resolution bandwidth of at least 30 kHz may be employed.

Rule Part 27.53(f) For operations in the 746-758 MHz, 775-788 MHz, and 805-806 MHz bands, emissions in the band 1559-1610 MHz shall be limited to  $-70$  dBW/MHz equivalent isotropically



radiated power (EIRP) for wideband signals, and  $-80$  dBW EIRP for discrete emissions of less than 700 Hz bandwidth. For the purpose of equipment authorization, a transmitter shall be tested with an antenna that is representative of the type that will be used with the equipment in normal operation.

Part 27.53 (c) For operations in the 746-758 MHz band and the 776-788 MHz band, the power of any emission outside the licensee's frequency band(s) of operation shall be attenuated below the transmitter power (P) within the licensed band(s) of operation, measured in watts, in accordance with the following:

- (1) On any frequency outside the 746-758 MHz band, the power of any emission shall be attenuated outside the band below the transmitter power (P) by at least  $43 + 10 \log (P)$  dB;
- (2) On any frequency outside the 776-788 MHz band, the power of any emission shall be attenuated outside the band below the transmitter power (P) by at least  $43 + 10 \log (P)$  dB;
- (3) On all frequencies between 763-775 MHz and 793-805 MHz, by a factor not less than  $76 + 10 \log (P)$  dB in a 6.25 kHz band segment, for base and fixed stations;
- (4) On all frequencies between 763-775 MHz and 793-805 MHz, by a factor not less than  $65 + 10 \log (P)$  dB in a 6.25 kHz band segment, for mobile and portable stations;
- (5) Compliance with the provisions of paragraphs (c)(1) and (c)(2) of this section is based on the use of measurement instrumentation employing a resolution bandwidth of 100 kHz or greater. However, in the 100 kHz bands immediately outside and adjacent to the frequency block, a resolution bandwidth of at least 30 kHz may be employed;

Part 27.53 (h)/(g) Limit		-13 dBm
Part 27.53(f)/(c) Limit	Limit out of the band 1559-1610 MHz	-13 dBm
	Limit in the band 1559-1610 MHz	-40 dBm

### Measurement Uncertainty

The assessed measurement uncertainty to ensure 99.75% confidence level for the normal distribution is with the coverage factor  $k = 1.96$ .

Frequency	Uncertainty
9kHz-1GHz	0.684 dB
1GHz-27GHz	1.407 dB



### Test Result

Sweep the whole frequency band through the range from 9kHz to the 10th harmonic of the carrier, the emissions more than 20 dB below the limit are not reported.

The signal beyond the limit is carrier.

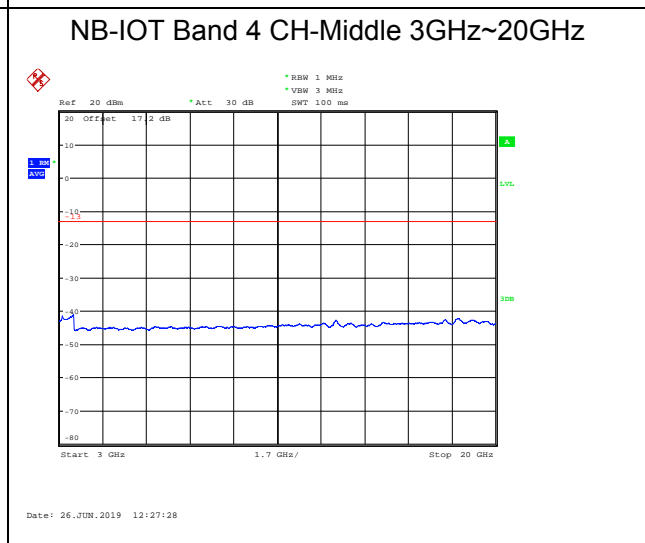
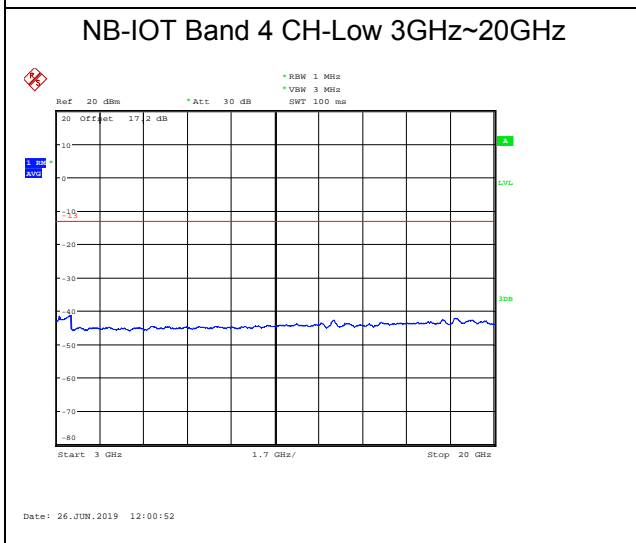
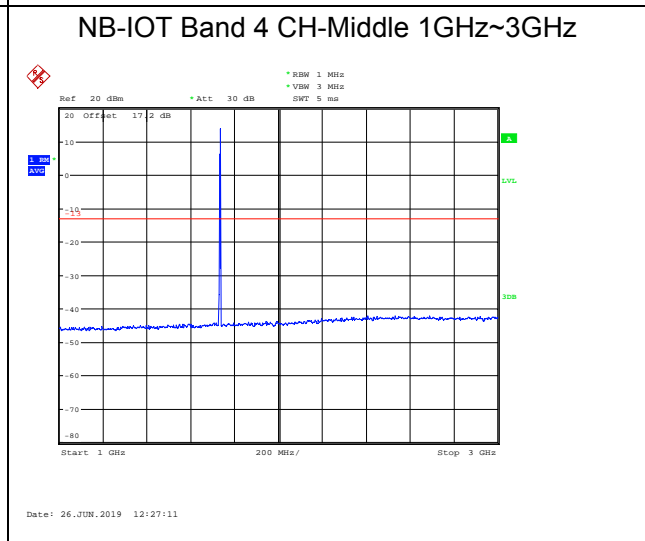
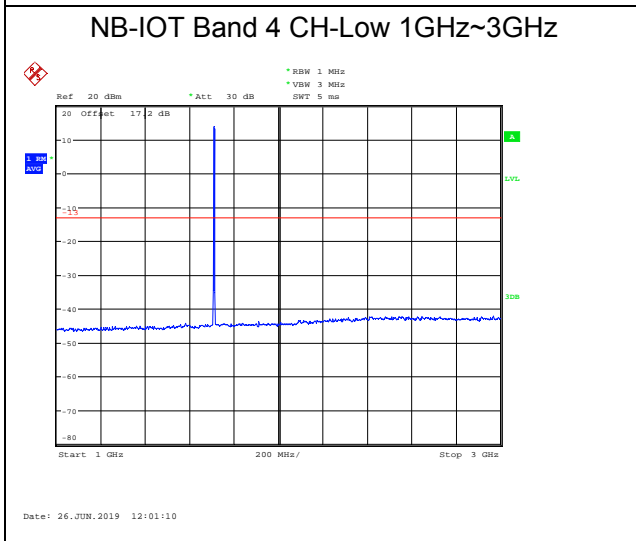
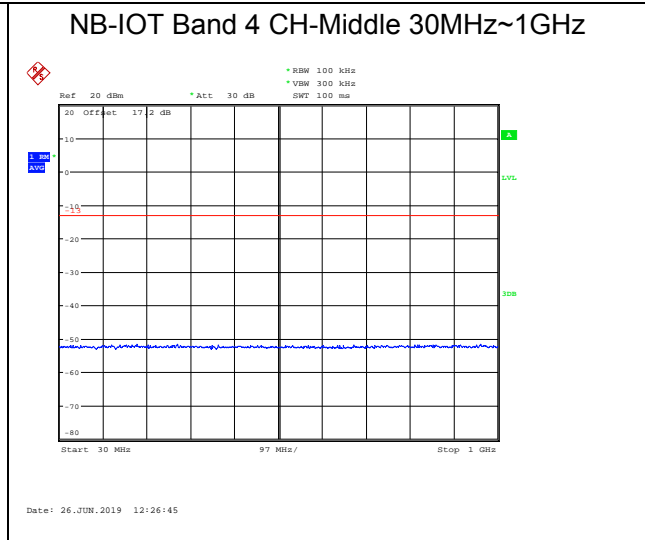
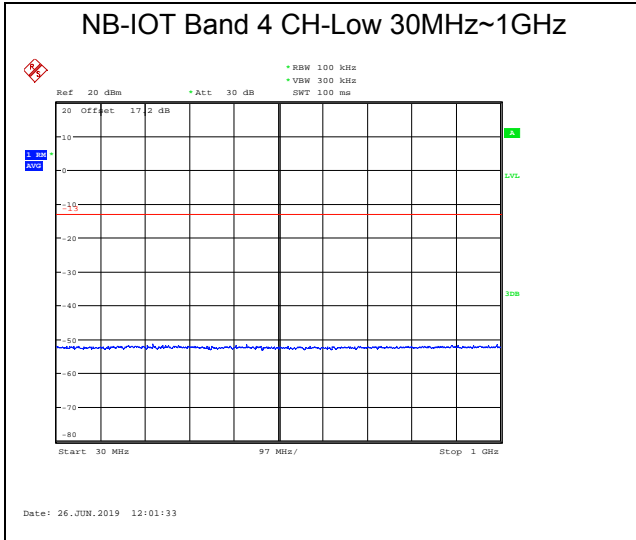



### NB-IOT Band 4 CH-High 30MHz~1GHz

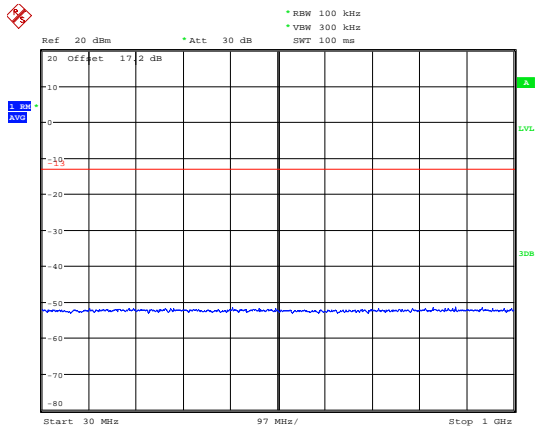

Date: 26.JUN.2019 12:35:59

### NB-IOT Band 4 CH-High 1GHz~3GHz

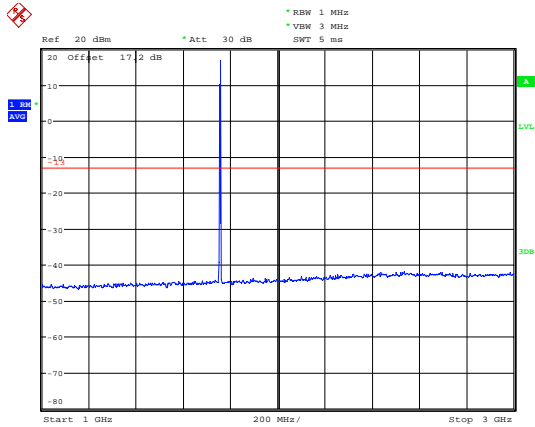

Date: 26.JUN.2019 12:35:33

### NB-IOT Band 4 CH-High 3GHz~20GHz

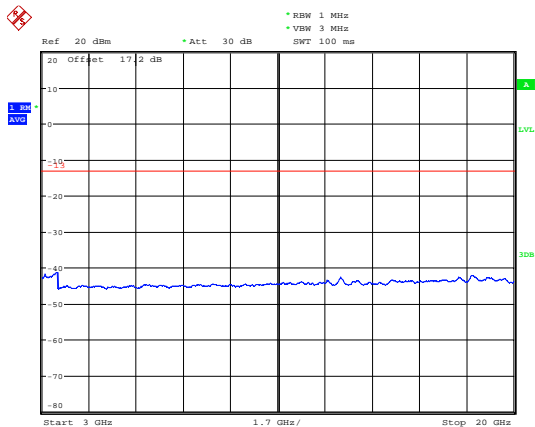

Date: 26.JUN.2019 12:35:16



### NB-IOT Band 12 CH-Low 30MHz-1GHz

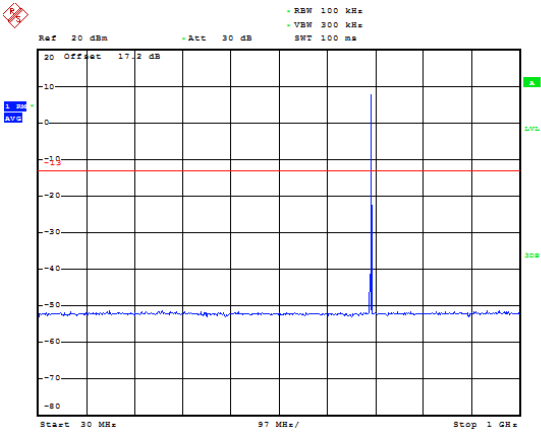

Date: 26.JUN.2019 16:11:28

### NB-IOT Band 12 CH-Low 1GHz-9GHz

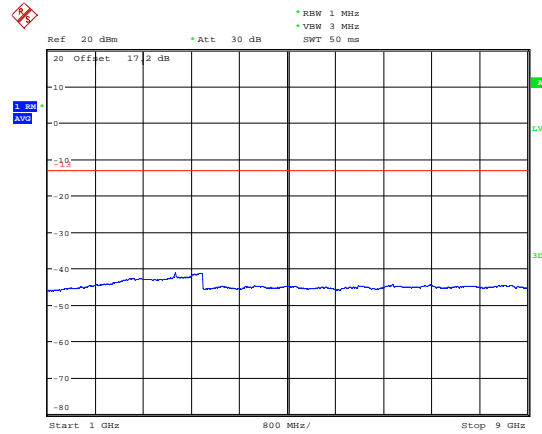

Date: 26.JUN.2019 16:11:51

### NB-IOT Band 12 CH-Middle 30MHz-1GHz

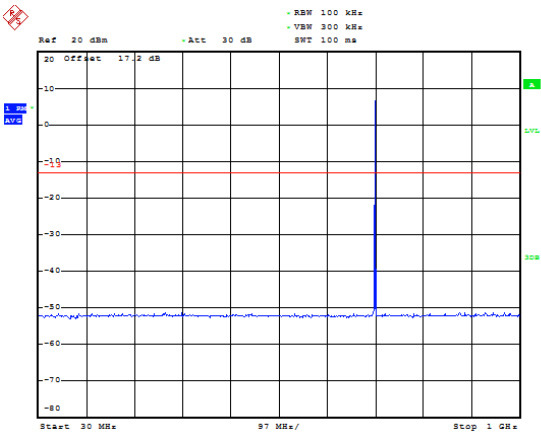

Date: 26.JUN.2019 16:15:55

### NB-IOT Band 12 CH-Middle 1GHz-9GHz

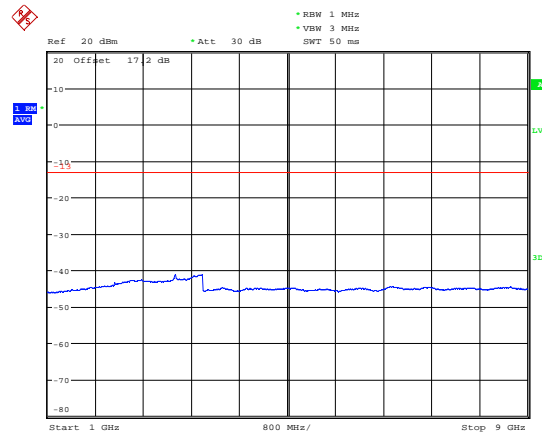

Date: 26.JUN.2019 16:15:18

### NB-IOT Band 12 CH-High 30MHz-1GHz

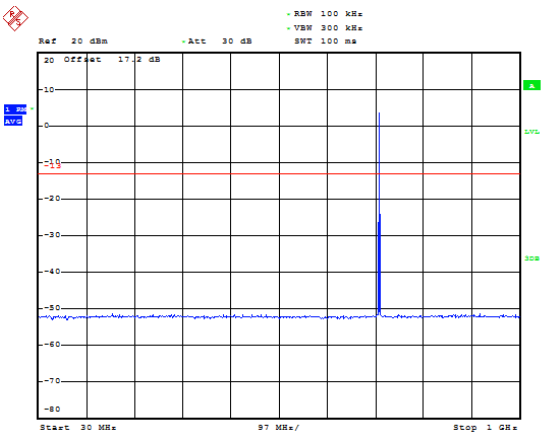

Date: 26.JUN.2019 16:30:23

### NB-IOT Band 12 CH-High 1GHz-9GHz

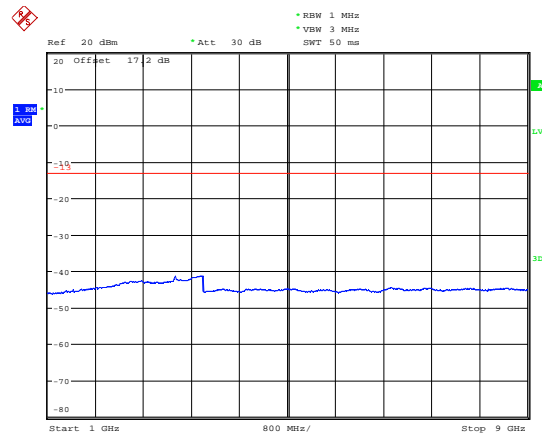

Date: 26.JUN.2019 16:30:40



### NB-IOT Band 13 CH-Low 30MHz-1GHz

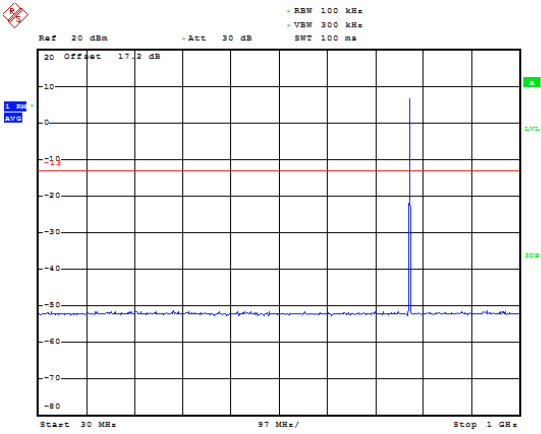

Date: 26.JUN.2019 16:51:06

### NB-IOT Band 13 CH-Low 1GHz-9GHz

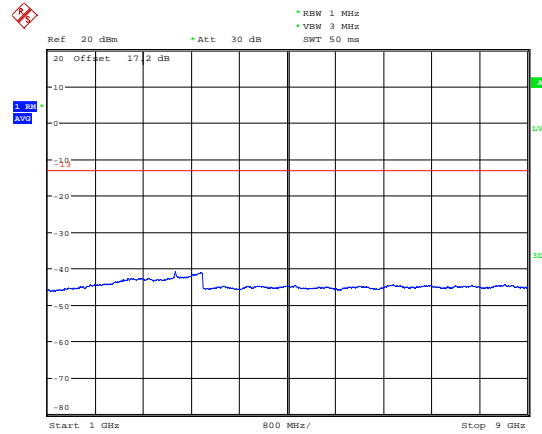

Date: 26.JUN.2019 16:50:38

### NB-IOT Band 13 CH-Middle 30MHz-1GHz

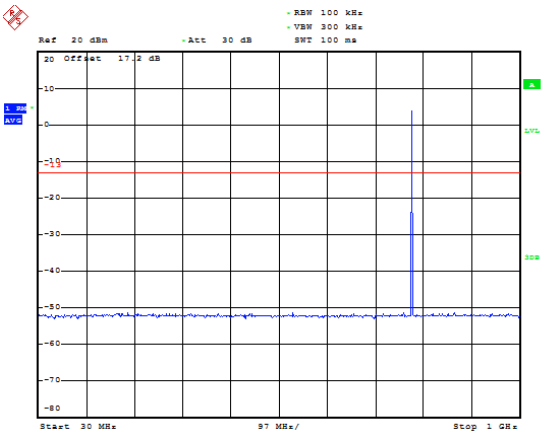

Date: 26.JUN.2019 17:40:57

### NB-IOT Band 13 CH-Middle 1GHz-9GHz

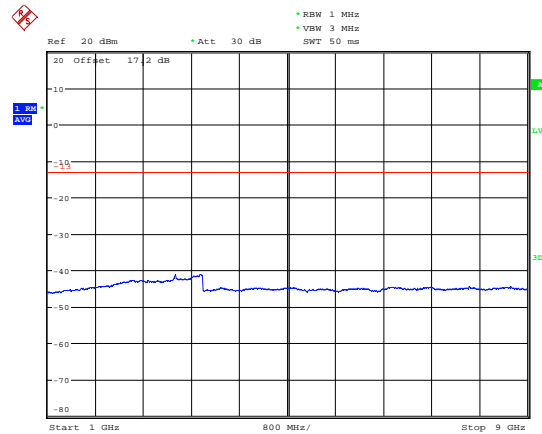

Date: 26.JUN.2019 17:41:15

### NB-IOT Band 13 CH-High 30MHz-1GHz

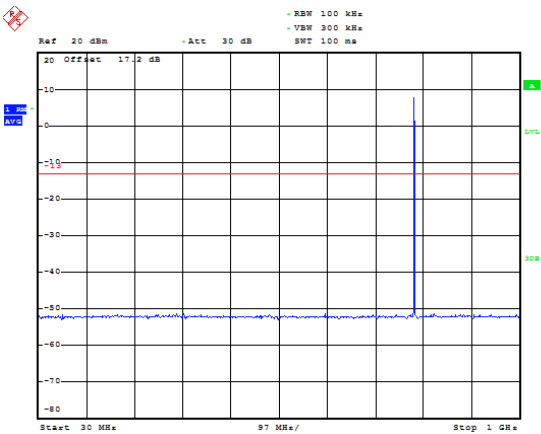

Date: 26.JUN.2019 17:58:22

### NB-IOT Band 13 CH-High 1GHz-9GHz

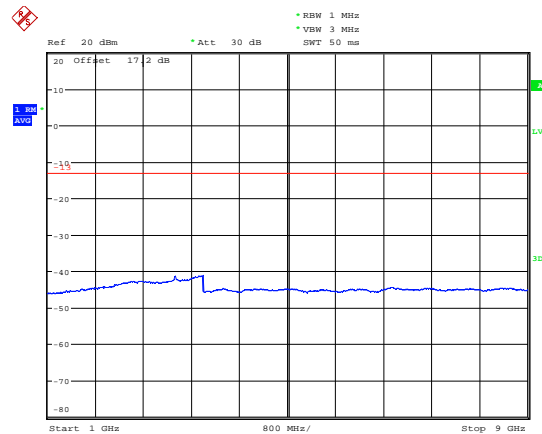

Date: 26.JUN.2019 17:58:09



### NB-IOT Band 17 CH-Low 30MHz-1GHz

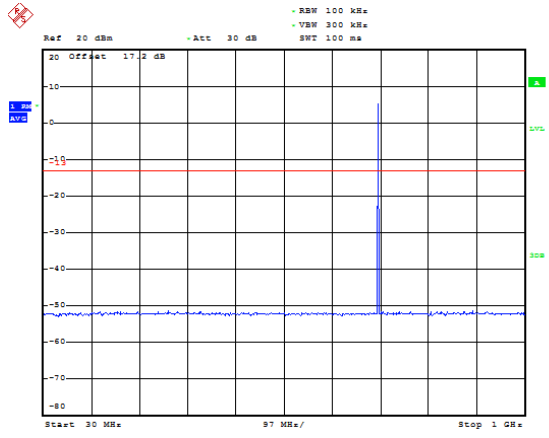

Date: 27.JUN.2019 10:51:01

### NB-IOT Band 17 CH-Low 1GHz-9GHz

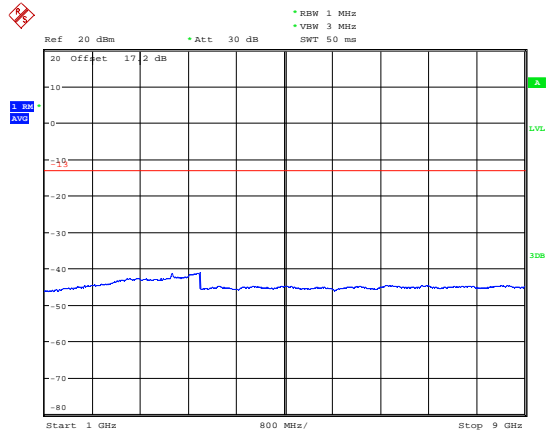

Date: 27.JUN.2019 10:51:50

### NB-IOT Band 17 CH-Middle 30MHz-1GHz

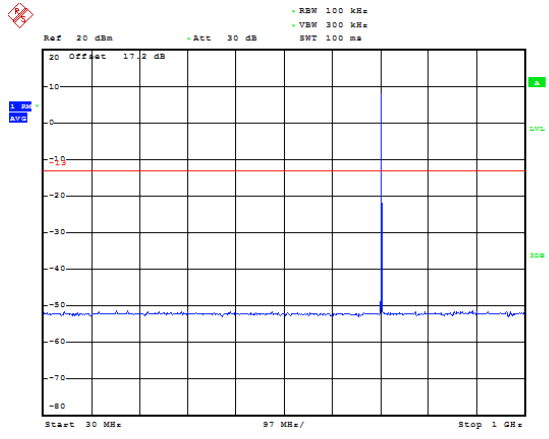

Date: 27.JUN.2019 10:52:44

### NB-IOT Band 17 CH-Middle 1GHz-9GHz

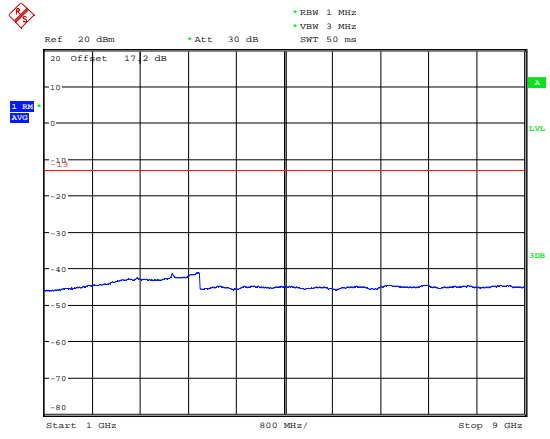

Date: 27.JUN.2019 10:52:16

### NB-IOT Band 17 CH-High 30MHz-1GHz

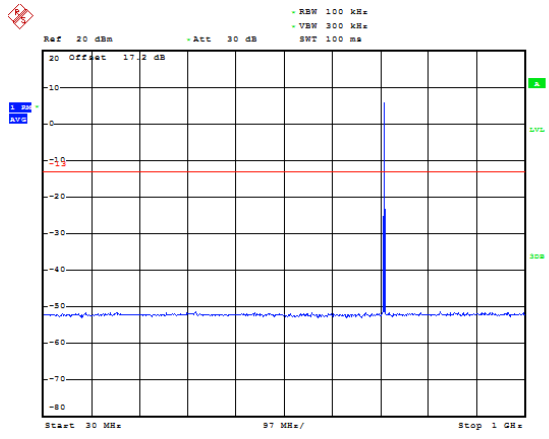

Date: 27.JUN.2019 11:01:19

### NB-IOT Band 17 CH-High 1GHz-9GHz

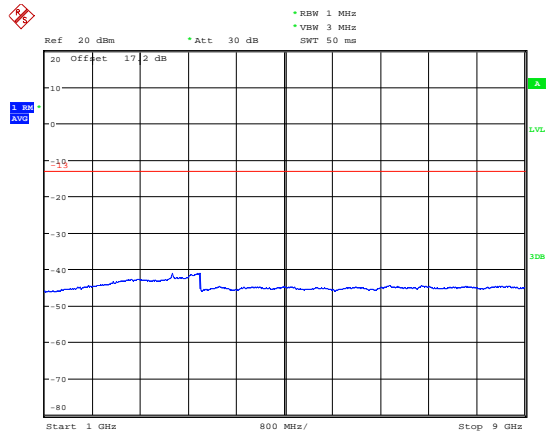

Date: 27.JUN.2019 11:01:41



### NB-IOT Band 66 CH-Low 30MHz~1GHz

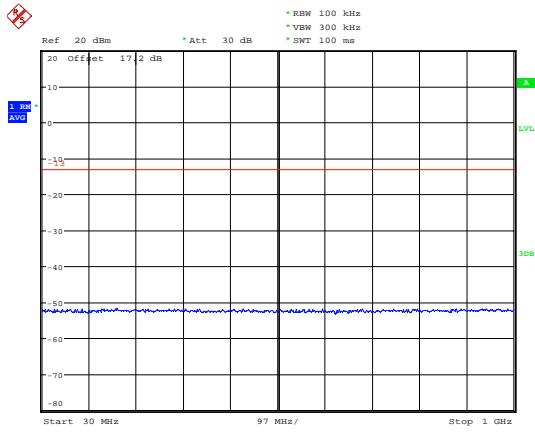

Date: 27.JUN.2019 13:14:14

### NB-IOT Band 66 CH-Middle 30MHz~1GHz

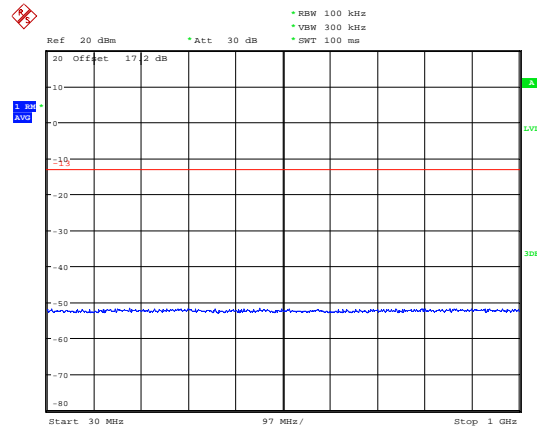

Date: 27.JUN.2019 13:14:27

### NB-IOT Band 66 CH-Low 1GHz~3GHz

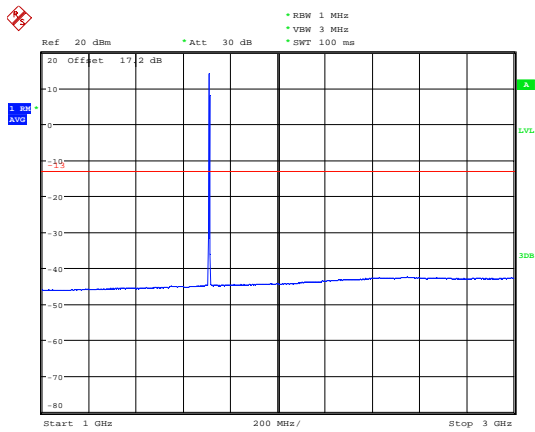

Date: 27.JUN.2019 14:59:28

### NB-IOT Band 66 CH-Middle 1GHz~3GHz

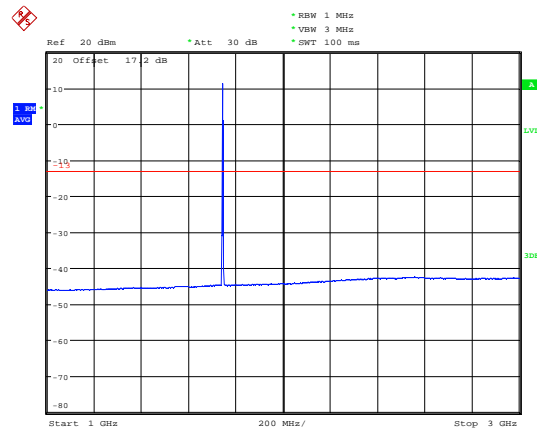

Date: 27.JUN.2019 15:04:53

### NB-IOT Band 66 CH-Low 3GHz~20GHz

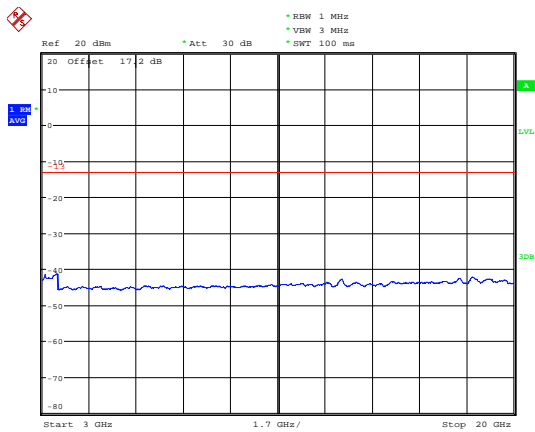

Date: 27.JUN.2019 15:00:39

### NB-IOT Band 66 CH-Middle 3GHz~20GHz

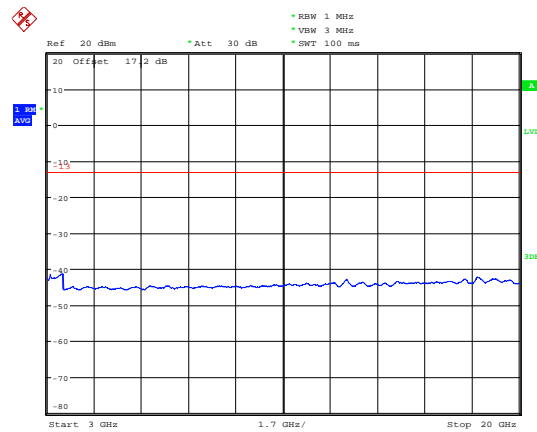

Date: 27.JUN.2019 15:04:37





### NB-IOT Band 66 CH-High 30MHz~1GHz

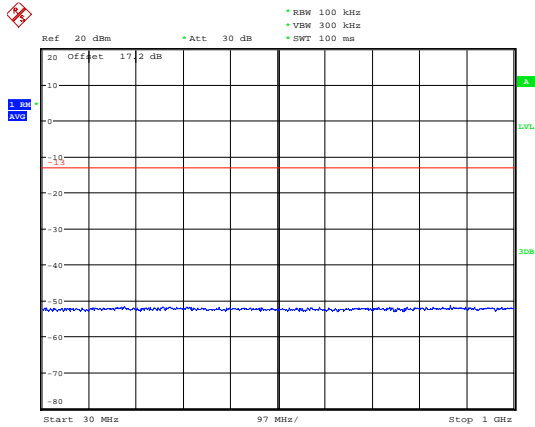

Date: 27.JUN.2019 13:14:44

### NB-IOT Band 66 CH-High 1GHz~3GHz

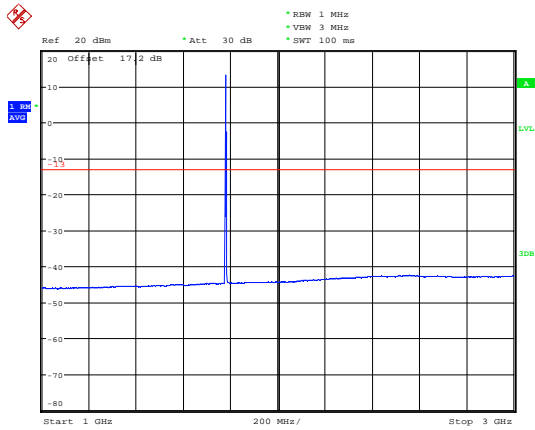

Date: 27.JUN.2019 15:07:36

### NB-IOT Band 66 CH-High 3GHz~20GHz

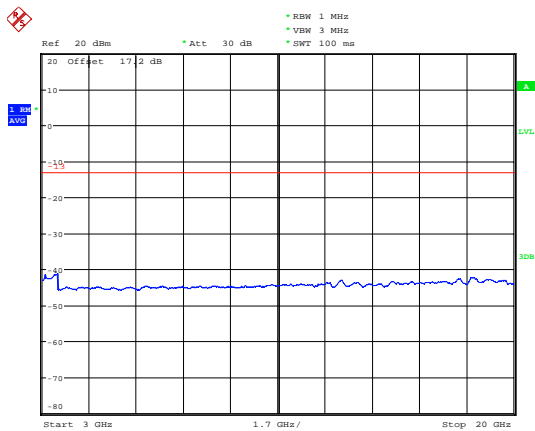

Date: 27.JUN.2019 15:07:59



### NB-IOT Band 71 CH-Low 30MHz-1GHz

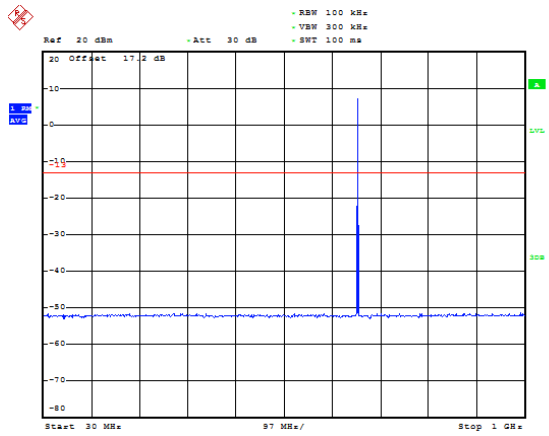

Date: 27.JUN.2019 15:11:09

### NB-IOT Band 71 CH-Low 1GHz-9GHz

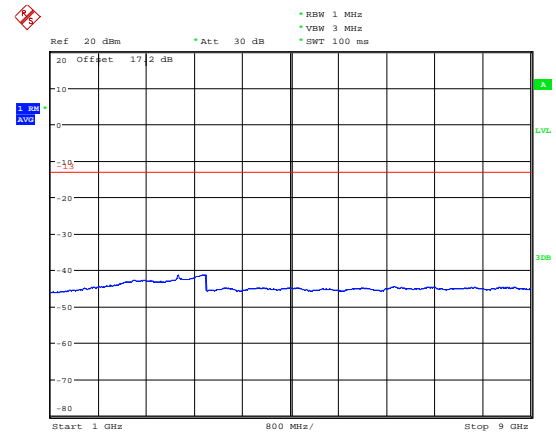

Date: 27.JUN.2019 15:09:21

### NB-IOT Band 71 CH-Middle 30MHz-1GHz

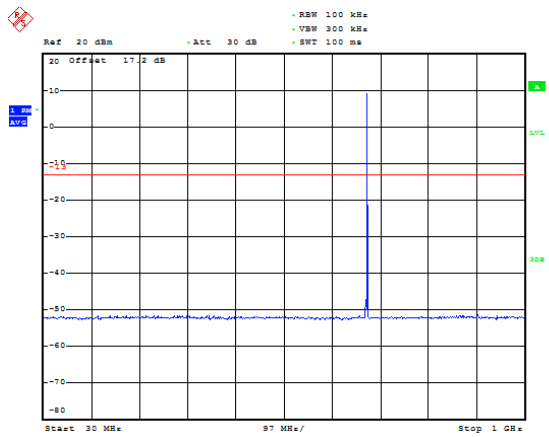

Date: 27.JUN.2019 15:11:09

### NB-IOT Band 71 CH-Middle 1GHz-9GHz

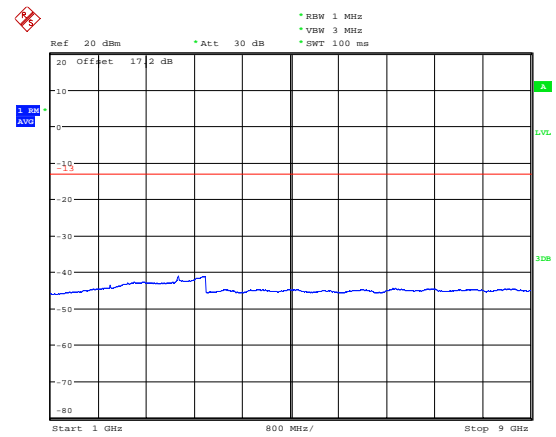

Date: 27.JUN.2019 15:10:05

### NB-IOT Band 71 CH-High 30MHz-1GHz

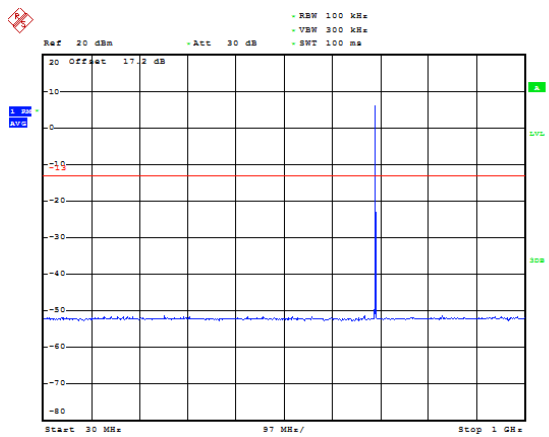

Date: 27.JUN.2019 15:12:12

### NB-IOT Band 71 CH-High 1GHz-9GHz

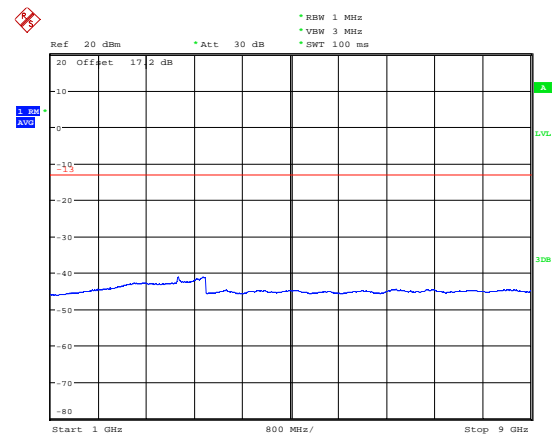

Date: 27.JUN.2019 15:10:39



### NB-IOT Band 85 CH-Low 30MHz-1GHz

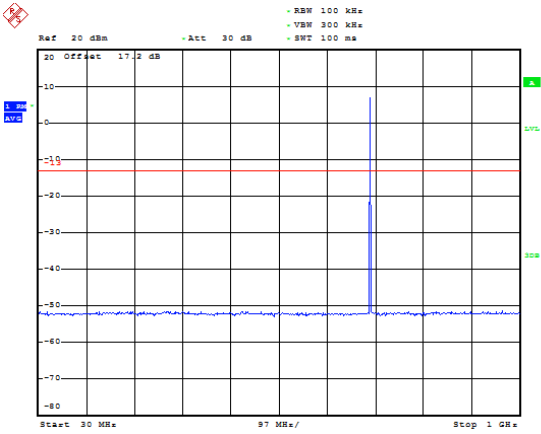

Date: 27.JUN.2019 17:15:17

### NB-IOT Band 85 CH-Low 1GHz-9GHz

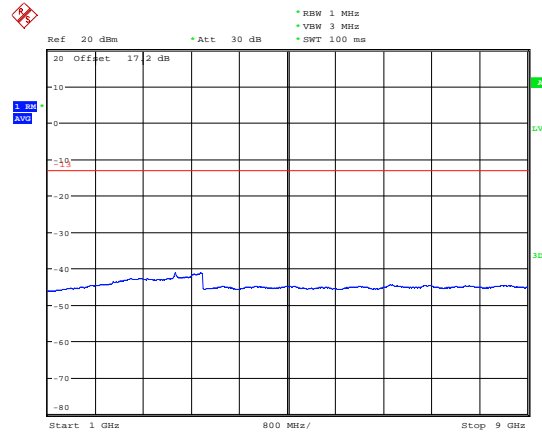

Date: 27.JUN.2019 17:15:43

### NB-IOT Band 85 CH-Middle 30MHz-1GHz

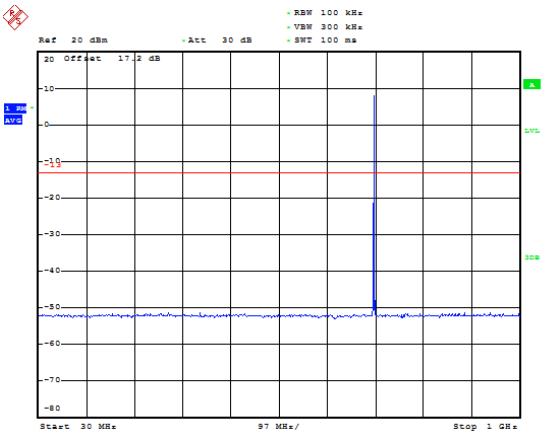

Date: 27.JUN.2019 17:09:10

### NB-IOT Band 85 CH-Middle 1GHz-9GHz

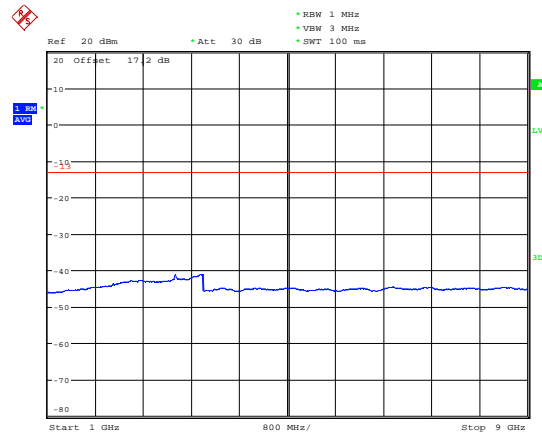

Date: 27.JUN.2019 17:16:02

### NB-IOT Band 85 CH-High 30MHz-1GHz

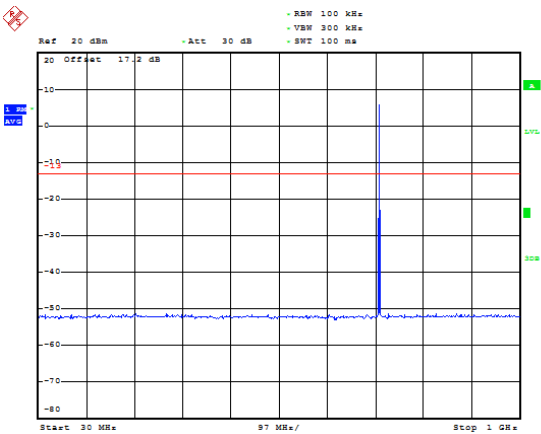

Date: 27.JUN.2019 17:04:49

### NB-IOT Band 85 CH-High 1GHz-9GHz

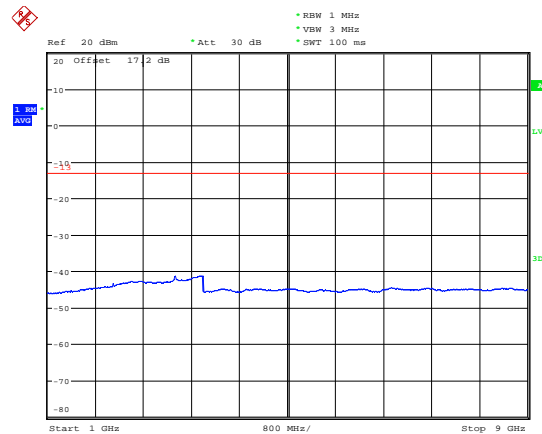

Date: 27.JUN.2019 17:20:59

## 5.8 Radiates Spurious Emission

### Ambient condition

Temperature	Relative humidity	Pressure
23°C ~25°C	45%~50%	101.5kPa

### Method of Measurement

1. The testing follows FCC KDB 971168 D01 v03r01 Section 5.8 and ANSI C63.26 (2015).
2. Below 1GHz: The EUT is placed on a turntable 0.8 meters above the ground in the chamber, 3 meter away from the antenna. The maximal emission value is acquired by adjusting the antenna height, polarisation and turntable azimuth. Normally, the height range of antenna is 1 m to 4 m, the azimuth range of turntable is 0° to 360°, and the receive antenna has two polarizations Vertical (V) and Horizontal (H). Above 1GHz: (Note: the FCC's permission to use 1.5m as an alternative per TCBC Conf call of Dec. 2, 2014.) The EUT is placed on a turntable 1.5 meters above the ground in the chamber, 3 meter away from the antenna. The maximal emission value is acquired by adjusting the antenna height, polarisation and turntable azimuth. Normally, the height range of antenna is 1 m to 4 m, the azimuth range of turntable is 0° to 360°, and the receive antenna has two polarizations Vertical (V) and Horizontal (H).
3. A loop antenna, A log-periodic antenna or horn antenna shall be substituted in place of the EUT. The log-periodic antenna will be driven by a signal generator and the level will be adjusted till the same power value on the spectrum analyzer or receiver. The level of the spurious emissions can be calculated through the level of the signal generator, cable loss, the gain of the substitution antenna and the reading of the spectrum analyzer or receiver.
4. The EUT is then put into continuously transmitting mode at its maximum power level during the test. Set Test Receiver or Spectrum RBW=200Hz,VBW=600Hz for 9kHz150kHz , RBW=10kHz, VBW=30kHz 150kHz-30MHz ,RBW=100kHz,VBW=300kHz for 30MHz to 1GHz and RBW=1MHz, VBW=3MHz for above 1GHz And the maximum value of the receiver should be recorded as (Pr).
5. The EUT shall be replaced by a substitution antenna. In the chamber, an substitution antenna for the frequency band of interest is placed at the reference point of the chamber. An RF Signal source for the frequency band of interest is connected to the substitution antenna with a cable that has been constructed to not interfere with the radiation pattern of the antenna. A power (PMea) is applied to the input of the substitution antenna, and adjust the level of the signal generator output until the value of the receiver reach the previously recorded (Pr). The power of signal source (PMea) is recorded. The test should be performed by rotating the test item and adjusting the receiving antenna polarization.
6. A amplifier should be connected to the Signal Source output port. And the cable should be connect between the Amplifier and the Substitution Antenna. The cable loss (Pcl) ,the Substitution Antenna Gain (Ga) and the Amplifier Gain (PAG) should be recorded after test.
7. The measurement results are obtained as described below:  
Power(EIRP)=PMea- PAG - Pcl + Ga  
The measurement results are amend as described below:  
Power(EIRP)=PMea- Pcl + Ga
8. This value is EIRP since the measurement is calibrated using an antenna of known gain (2.15 dBi) and known input power. ERP can be calculated from EIRP by subtracting the gain of the dipole, ERP

= EIRP-2.15dBi.

The modulation mode and RB allocation refer to section 5.1, using the maximum output power configuration.

**Test setup**

**9KHz ~ 30MHz**

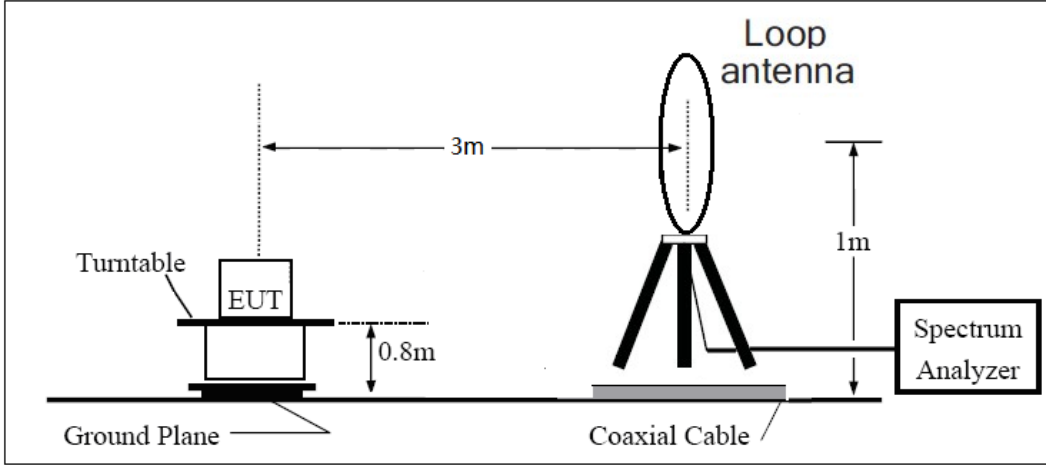

**30MHz ~ 1GHz**

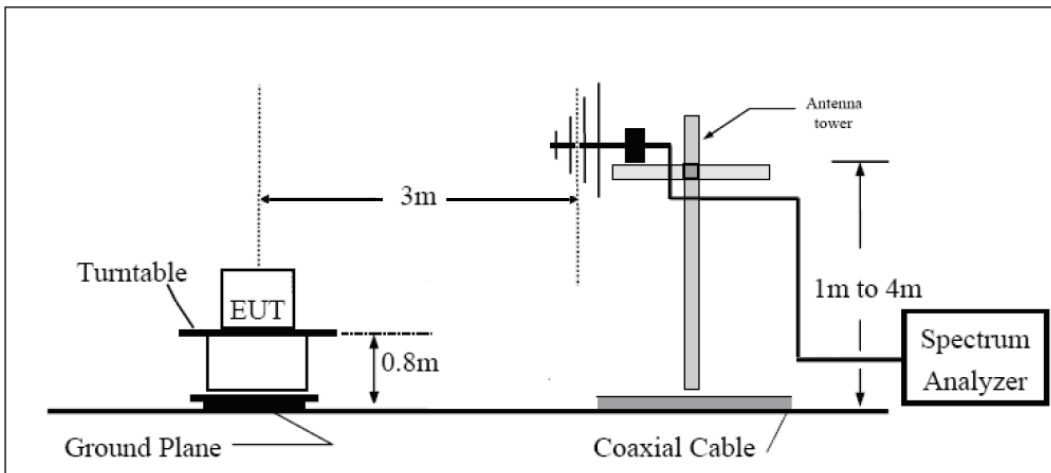

**Above 1GHz**

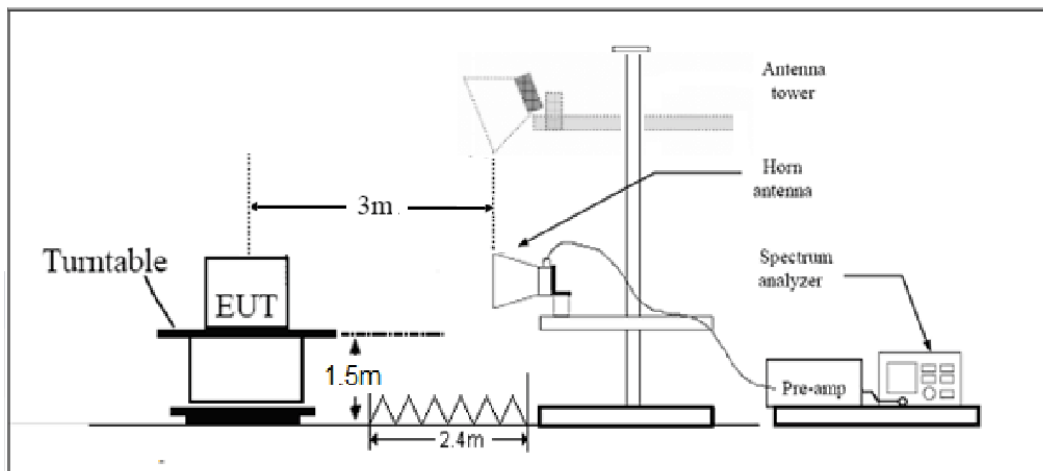

Note: Area side:2.4mX3.6m

**Limits**

Rule Part 27.53(h) specifies that “for operations in the 1695-1710 MHz, 1710-1755 MHz, 1755-1780 MHz, 1915-1920 MHz, 1995-2000 MHz, 2000-2020 MHz, 2110-2155 MHz, 2155-2180 MHz, and 2180-2200 bands, the power of any emission outside a licensee's frequency block shall be attenuated below the transmitter power (P) in watts by at least  $43 + 10 \log_{10}(P)$  dB.”

Rule Part 27.53 (g) For operations in the 600 MHz band and the 698-746 MHz band, the power of any emission outside a licensee's frequency band(s) of operation shall be attenuated below the transmitter power (P) within the licensed band(s) of operation, measured in watts, by at least  $43 + 10 \log(P)$  dB. Compliance with this provision is based on the use of measurement instrumentation employing a resolution bandwidth of 100 kilohertz or greater. However, in the 100 kilohertz bands immediately outside and adjacent to a licensee's frequency block, a resolution bandwidth of at least 30 kHz may be employed.

Rule Part 27.53(f) For operations in the 746-758 MHz, 775-788 MHz, and 805-806 MHz bands, emissions in the band 1559-1610 MHz shall be limited to  $-70$  dBW/MHz equivalent isotropically radiated power (EIRP) for wideband signals, and  $-80$  dBW EIRP for discrete emissions of less than 700 Hz bandwidth. For the purpose of equipment authorization, a transmitter shall be tested with an antenna that is representative of the type that will be used with the equipment in normal operation.

Part 27.53 (c) For operations in the 746-758 MHz band and the 776-788 MHz band, the power of any emission outside the licensee's frequency band(s) of operation shall be attenuated below the transmitter power (P) within the licensed band(s) of operation, measured in watts, in accordance with the following:

- (1) On any frequency outside the 746-758 MHz band, the power of any emission shall be attenuated outside the band below the transmitter power (P) by at least  $43 + 10 \log(P)$  dB;
- (2) On any frequency outside the 776-788 MHz band, the power of any emission shall be attenuated outside the band below the transmitter power (P) by at least  $43 + 10 \log(P)$  dB;
- (3) On all frequencies between 763-775 MHz and 793-805 MHz, by a factor not less than  $76 + 10 \log(P)$  dB in a 6.25 kHz band segment, for base and fixed stations;
- (4) On all frequencies between 763-775 MHz and 793-805 MHz, by a factor not less than  $65 + 10 \log(P)$  dB in a 6.25 kHz band segment, for mobile and portable stations;
- (5) Compliance with the provisions of paragraphs (c)(1) and (c)(2) of this section is based on the use of measurement instrumentation employing a resolution bandwidth of 100 kHz or greater. However, in the 100 kHz bands immediately outside and adjacent to the frequency block, a resolution bandwidth of at least 30 kHz may be employed;

Part 27.53(a)/(h)/(g) Limit		-13 dBm
Part 27.53(f)/(c) Limit	Limit out of the band 1559-1610 MHz	-13 dBm
	Limit in the band 1559-1610 MHz	-40 dBm

**Measurement Uncertainty**

The assessed measurement uncertainty to ensure 95% confidence level for the normal distribution is with the coverage factor  $k = \pm 1.96$ ,  $U = \pm 3.55$  dB.

**Test Result**

Sweep the whole frequency band through the range from 9kHz to the 10th harmonic of the carrier, the emissions below the noise floor will not be recorded in the report.

NB-IOT Band 4 CH-Low, RB 1

Harmonic	Frequency (MHz)	SG (dBm)	Cable Loss (dB)	Gain (dBi)	Antenna Polarization	EIRP Level (dBm)	Limit (dBm)	Margin (dB)	Azimuth (deg)
2	3419.6	-53.13	2.6	10.15	Horizontal	-45.58	-13.00	32.58	135
3	5131.1	-62.23	2.4	11.35	Horizontal	-53.28	-13.00	40.28	225
4	6842.8	-56.46	4.5	10.85	Horizontal	-50.11	-13.00	37.11	45
5	8553.5	-55.00	5.1	11.35	Horizontal	-48.75	-13.00	35.75	135
6	10264.2	-52.34	5.3	11.95	Horizontal	-45.69	-13.00	32.69	225
7	11974.9	-52.79	5.5	13.55	Horizontal	-44.74	-13.00	31.74	45
8	13685.6	-50.85	6.3	13.75	Horizontal	-43.40	-13.00	30.40	135
9	15396.3	-52.30	6.7	13.85	Horizontal	-45.15	-13.00	32.15	225
10	17107.0	-49.72	6.8	14.25	Horizontal	-42.27	-13.00	29.27	45

Note: 1.The other Spurious RF Radiated emissions level is no more than noise floor.

2. The worst emission was found in the antenna is Horizontal position.

NB-IOT Band 4 CH-Middle, RB 1

Harmonic	Frequency (MHz)	SG (dBm)	Cable Loss (dB)	Gain (dBi)	Antenna Polarization	EIRP Level (dBm)	Limit (dBm)	Margin (dB)	Azimuth (deg)
2	3464.3	-53.95	2.6	10.75	Horizontal	-45.80	-13.00	32.80	135
3	5197.5	-62.33	2.4	11.05	Horizontal	-53.68	-13.00	40.68	45
4	6930.0	-58.50	4.5	11.15	Horizontal	-51.85	-13.00	38.85	45
5	8662.5	-55.28	5.1	11.35	Horizontal	-49.03	-13.00	36.03	135
6	10395.0	-51.30	5.3	11.95	Horizontal	-44.65	-13.00	31.65	45
7	12127.5	-50.97	5.5	13.55	Horizontal	-42.92	-13.00	29.92	135
8	13860.0	-51.57	6.3	13.75	Horizontal	-44.12	-13.00	31.12	225
9	15592.5	-48.71	6.7	13.85	Horizontal	-41.56	-13.00	28.56	45
10	17325.0	-49.02	6.8	14.25	Horizontal	-41.57	-13.00	28.57	135

Note: 1.The other Spurious RF Radiated emissions level is no more than noise floor.

2. The worst emission was found in the antenna is Horizontal position.



## NB-IOT Band 4 CH-High, RB 1

Harmonic	Frequency (MHz)	SG (dBm)	Cable Loss (dB)	Gain (dBi)	Antenna Polarization	EIRP Level (dBm)	Limit (dBm)	Margin (dB)	Azimuth (deg)
2	3507.8	-54.22	2.6	10.15	Horizontal	-46.67	-13.00	33.67	225
3	5261.6	-62.69	2.4	11.05	Horizontal	-54.04	-13.00	41.04	45
4	7017.2	-55.07	4.5	11.15	Horizontal	-48.42	-13.00	35.42	135
5	8771.5	-54.98	5.1	11.35	Horizontal	-48.73	-13.00	35.73	225
6	10525.8	-53.11	5.3	11.95	Horizontal	-46.46	-13.00	33.46	45
7	12280.1	-52.28	5.5	13.55	Horizontal	-44.23	-13.00	31.23	135
8	14034.4	-49.11	6.3	13.75	Horizontal	-41.66	-13.00	28.66	225
9	15788.7	-52.62	6.7	13.85	Horizontal	-45.47	-13.00	32.47	45
10	17543.0	-49.10	6.8	14.25	Horizontal	-41.65	-13.00	28.65	135

Note: 1. The other Spurious RF Radiated emissions level is no more than noise floor.

2. The worst emission was found in the antenna is Horizontal position.

## NB-IOT Band 12 CH-Low, RB 1

Harmonic	Frequency (MHz)	SG (dBm)	Cable Loss (dB)	Gain (dBi)	Antenna Polarization	ERP Level (dBm)	Limit (dBm)	Margin (dB)	Azimuth (deg)
2	1399.4	-49.53	2.00	10.15	Horizontal	-43.53	-13.00	30.53	135
3	2099.1	-49.81	2.50	11.35	Horizontal	-43.11	-13.00	30.11	90
4	2798.8	-62.76	4.20	10.85	Horizontal	-58.26	-13.00	45.26	180
5	3498.5	-63.21	5.20	11.35	Horizontal	-59.21	-13.00	46.21	135
6	4198.2	-61.38	5.50	11.95	Horizontal	-57.08	-13.00	44.08	225
7	4897.9	-56.22	5.70	13.55	Horizontal	-50.52	-13.00	37.52	45
8	5597.6	-60.76	6.30	13.75	Horizontal	-55.46	-13.00	42.46	135
9	6297.3	-58.59	6.80	13.85	Horizontal	-53.69	-13.00	40.69	225
10	6997.0	-57.02	6.90	14.25	Horizontal	-51.82	-13.00	38.82	45

Note: 1. The other Spurious RF Radiated emissions level is no more than noise floor.

2. The worst emission was found in the antenna is Horizontal position.





## NB-IOT Band 12 CH-Middle, RB 1

Harmonic	Frequency (MHz)	SG (dBm)	Cable Loss (dB)	Gain (dBi)	Antenna Polarization	ERP Level (dBm)	Limit (dBm)	Margin (dB)	Azimuth (deg)
2	1415.0	-45.88	2.00	10.75	Horizontal	-39.28	-13.00	26.28	135
3	2122.5	-47.78	2.51	11.05	Horizontal	-41.39	-13.00	28.39	225
4	2830.0	-62.92	4.20	11.15	Horizontal	-58.12	-13.00	45.12	45
5	3537.5	-61.55	5.20	11.15	Horizontal	-57.75	-13.00	44.75	135
6	4245.0	-61.80	5.50	11.95	Horizontal	-57.50	-13.00	44.50	0
7	4952.5	-53.39	5.70	13.55	Horizontal	-47.69	-13.00	34.69	90
8	5660.0	-59.95	6.30	13.75	Horizontal	-54.65	-13.00	41.65	135
9	6367.5	-57.51	6.80	13.85	Horizontal	-52.61	-13.00	39.61	90
10	7075.0	-55.16	6.90	14.25	Horizontal	-49.96	-13.00	36.96	180

Note: 1. The other Spurious RF Radiated emissions level is no more than noise floor.  
2. The worst emission was found in the antenna is Horizontal position.

## NB-IOT Band 12 CH-High, RB 1

Harmonic	Frequency (MHz)	SG (dBm)	Cable Loss (dB)	Gain (dBi)	Antenna Polarization	ERP Level (dBm)	Limit (dBm)	Margin (dB)	Azimuth (deg)
2	1430.6	-48.19	2.00	10.15	Horizontal	-42.19	-13.00	29.19	135
3	2145.9	-47.51	2.51	11.05	Horizontal	-41.12	-13.00	28.12	0
4	2861.2	-63.98	4.20	11.15	Horizontal	-59.18	-13.00	46.18	90
5	3576.5	-62.45	5.20	11.15	Horizontal	-58.65	-13.00	45.65	135
6	4291.8	-59.84	5.50	11.95	Horizontal	-55.54	-13.00	42.54	225
7	5007.1	-56.60	5.70	13.55	Horizontal	-50.90	-13.00	37.90	45
8	5722.4	-60.67	6.30	13.75	Horizontal	-55.37	-13.00	42.37	270
9	6437.7	-56.44	6.80	13.85	Horizontal	-51.54	-13.00	38.54	315
10	7153.0	-54.32	6.90	14.25	Horizontal	-49.12	-13.00	36.12	225

Note: 1. The other Spurious RF Radiated emissions level is no more than noise floor.  
2. The worst emission was found in the antenna is Horizontal position.



## NB-IOT Band 13 CH-Low, RB 1

Harmonic	Frequency (MHz)	SG (dBm)	Cable Loss (dB)	Gain (dBi)	Antenna Polarization	ERP Level (dBm)	Limit (dBm)	Margin (dB)	Azimuth (deg)
2	1555.8	-49.16	2.00	10.15	Horizontal	-43.16	-13.00	30.16	0
3	2338.5	-49.34	2.50	11.35	Horizontal	-42.64	-13.00	29.64	90
4	3118.0	-61.73	4.20	10.85	Horizontal	-57.23	-13.00	44.23	270
5	3897.5	-58.35	5.20	11.35	Horizontal	-54.35	-13.00	41.35	315
6	4677.0	-52.52	5.50	11.95	Horizontal	-48.22	-13.00	35.22	225
7	5456.5	-59.42	5.70	13.55	Horizontal	-53.72	-13.00	40.72	225
8	6236.0	-58.93	6.30	13.75	Horizontal	-53.63	-13.00	40.63	45
9	7015.5	-55.51	6.80	13.85	Horizontal	-50.61	-13.00	37.61	135
10	7795.0	-54.34	6.90	14.25	Horizontal	-49.14	-13.00	36.14	0

Note: 1. The other Spurious RF Radiated emissions level is no more than noise floor.

2. The worst emission was found in the antenna is Horizontal position.

## NB-IOT Band 13 CH-Middle, RB 1

Harmonic	Frequency (MHz)	SG (dBm)	Cable Loss (dB)	Gain (dBi)	Antenna Polarization	EIRP Level (dBm)	Limit (dBm)	Margin (dB)	Azimuth (deg)
2	1564.0	-55.86	2.00	10.75	Horizontal	-49.26	-40.00	9.26	135
Harmonic	Frequency (MHz)	SG (dBm)	Cable Loss (dB)	Gain (dBi)	Antenna Polarization	ERP Level (dBm)	Limit (dBm)	Margin (dB)	Azimuth (deg)
3	2346.0	-54.30	2.51	11.05	Horizontal	-47.91	-13.00	34.91	90
4	3128.0	-60.26	4.20	11.15	Horizontal	-55.46	-13.00	42.46	135
5	3910.0	-56.15	5.20	11.15	Horizontal	-52.35	-13.00	39.35	225
6	4692.0	-54.25	5.50	11.95	Horizontal	-49.95	-13.00	36.95	45
7	5474.0	-60.90	5.70	13.55	Horizontal	-55.20	-13.00	42.20	135
8	6256.0	-56.67	6.30	13.75	Horizontal	-51.37	-13.00	38.37	135
9	7038.0	-55.51	6.80	13.85	Horizontal	-50.61	-13.00	37.61	225
10	7820.0	-54.74	6.90	14.25	Horizontal	-49.54	-13.00	36.54	180

Note: 1. The other Spurious RF Radiated emissions level is no more than noise floor.

2. The worst emission was found in the antenna is Horizontal position.



## NB-IOT Band 13 CH-High, RB 1

Harmonic	Frequency (MHz)	SG (dBm)	Cable Loss (dB)	Gain (dBi)	Antenna Polarization	ERP Level (dBm)	Limit (dBm)	Margin (dB)	Azimuth (deg)
2	1569.0	-50.97	2.00	10.15	Horizontal	-44.97	-13.00	31.97	180
3	2353.5	-53.90	2.51	11.05	Horizontal	-47.51	-13.00	34.51	135
4	3138.0	-64.18	4.20	11.15	Horizontal	-59.38	-13.00	46.38	135
5	3922.5	-61.07	5.20	11.15	Horizontal	-57.27	-13.00	44.27	225
6	4707.0	-52.33	5.50	11.95	Horizontal	-48.03	-13.00	35.03	45
7	5491.5	-60.58	5.70	13.55	Horizontal	-54.88	-13.00	41.88	135
8	6276.0	-58.89	6.30	13.75	Horizontal	-53.59	-13.00	40.59	0
9	7060.5	-55.03	6.80	13.85	Horizontal	-50.13	-13.00	37.13	225
10	7845.0	-53.59	6.90	14.25	Horizontal	-48.39	-13.00	35.39	45

Note: 1. The other Spurious RF Radiated emissions level is no more than noise floor.

2. The worst emission was found in the antenna is Horizontal position.

## NB-IOT Band 17 CH-Low, RB 1

Harmonic	Frequency (MHz)	SG (dBm)	Cable Loss (dB)	Gain (dBi)	Antenna Polarization	ERP Level (dBm)	Limit (dBm)	Margin (dB)	Azimuth (deg)
2	1413.0	-45.42	2.00	10.15	Horizontal	-39.42	-13.00	26.42	225
3	2119.5	-46.60	2.50	11.35	Horizontal	-39.90	-13.00	26.90	45
4	2826.0	-60.83	4.20	10.85	Horizontal	-56.33	-13.00	43.33	135
5	3532.5	-61.80	5.20	11.35	Horizontal	-57.80	-13.00	44.80	90
6	4239.0	-60.07	5.50	11.95	Horizontal	-55.77	-13.00	42.77	135
7	4945.5	-61.25	5.70	13.55	Horizontal	-55.55	-13.00	42.55	225
8	5652.0	-61.42	6.30	13.75	Horizontal	-56.12	-13.00	43.12	45
9	6358.5	-57.40	6.80	13.85	Horizontal	-52.50	-13.00	39.50	135
10	7065.0	-55.97	6.90	14.25	Horizontal	-50.77	-13.00	37.77	225

Note: 1. The other Spurious RF Radiated emissions level is no more than noise floor.

2. The worst emission was found in the antenna is Horizontal position.



## NB-IOT Band 17 CH-Middle, RB 1

Harmonic	Frequency (MHz)	SG (dBm)	Cable Loss (dB)	Gain (dBi)	Antenna Polarization	ERP Level (dBm)	Limit (dBm)	Margin (dB)	Azimuth (deg)
2	1420.0	-45.54	2.00	10.75	Horizontal	-38.94	-13.00	25.94	0
3	2130.0	-47.90	2.51	11.05	Horizontal	-41.51	-13.00	28.51	135
4	2840.0	-63.89	4.20	11.15	Horizontal	-59.09	-13.00	46.09	225
5	3550.0	-62.90	5.20	11.15	Horizontal	-59.10	-13.00	46.10	45
6	4260.0	-60.17	5.50	11.95	Horizontal	-55.87	-13.00	42.87	135
7	4970.0	-57.63	5.70	13.55	Horizontal	-51.93	-13.00	38.93	45
8	5680.0	-60.05	6.30	13.75	Horizontal	-54.75	-13.00	41.75	135
9	6390.0	-58.57	6.80	13.85	Horizontal	-53.67	-13.00	40.67	0
10	7100.0	-54.53	6.90	14.25	Horizontal	-49.33	-13.00	36.33	90

Note: 1. The other Spurious RF Radiated emissions level is no more than noise floor.

2. The worst emission was found in the antenna is Horizontal position.

## NB-IOT Band 17 CH-High, RB 1

Harmonic	Frequency (MHz)	SG (dBm)	Cable Loss (dB)	Gain (dBi)	Antenna Polarization	ERP Level (dBm)	Limit (dBm)	Margin (dB)	Azimuth (deg)
2	1427.0	-48.11	2.00	10.15	Horizontal	-42.11	-13.00	29.11	45
3	2140.5	-48.70	2.51	11.05	Horizontal	-42.31	-13.00	29.31	135
4	2854.0	-63.16	4.20	11.15	Horizontal	-58.36	-13.00	45.36	0
5	3567.5	-61.48	5.20	11.15	Horizontal	-57.68	-13.00	44.68	135
6	4281.0	-61.41	5.50	11.95	Horizontal	-57.11	-13.00	44.11	225
7	4994.5	-54.70	5.70	13.55	Horizontal	-49.00	-13.00	36.00	45
8	5708.0	-59.75	6.30	13.75	Horizontal	-54.45	-13.00	41.45	270
9	6421.5	-58.50	6.80	13.85	Horizontal	-53.60	-13.00	40.60	315
10	7135.0	-54.28	6.90	14.25	Horizontal	-49.08	-13.00	36.08	0

Note: 1. The other Spurious RF Radiated emissions level is no more than noise floor.

2. The worst emission was found in the antenna is Horizontal position.



## NB-IOT Band 66 CH-Low, RB 1

Harmonic	Frequency (MHz)	SG (dBm)	Cable Loss (dB)	Gain (dBi)	Antenna Polarization	EIRP Level (dBm)	Limit (dBm)	Margin (dB)	Azimuth (deg)
2	3426.0	-54.21	2.6	10.15	Horizontal	-46.66	-13.00	33.66	135
3	5131.1	-61.03	2.4	11.35	Horizontal	-52.08	-13.00	39.08	225
4	6842.8	-57.47	4.5	10.85	Horizontal	-51.12	-13.00	38.12	45
5	8553.5	-54.06	5.1	11.35	Horizontal	-47.81	-13.00	34.81	135
6	10264.2	-53.11	5.3	11.95	Horizontal	-46.46	-13.00	33.46	225
7	11974.9	-51.52	5.5	13.55	Horizontal	-43.47	-13.00	30.47	45
8	13685.6	-51.21	6.3	13.75	Horizontal	-43.76	-13.00	30.76	135
9	15396.3	-49.44	6.7	13.85	Horizontal	-42.29	-13.00	29.29	45
10	17107.0	-48.71	6.8	14.25	Horizontal	-41.26	-13.00	28.26	135

Note: 1. The other Spurious RF Radiated emissions level is no more than noise floor.  
2. The worst emission was found in the antenna is Horizontal position.

## NB-IOT Band 66 CH-Middle, RB 1

Harmonic	Frequency (MHz)	SG (dBm)	Cable Loss (dB)	Gain (dBi)	Antenna Polarization	EIRP Level (dBm)	Limit (dBm)	Margin (dB)	Azimuth (deg)
2	3490.0	-56.07	2.6	10.75	Horizontal	-47.92	-13.00	34.92	135
3	5235.0	-62.44	2.4	11.05	Horizontal	-53.79	-13.00	40.79	45
4	6980.0	-57.24	4.5	11.15	Horizontal	-50.59	-13.00	37.59	135
5	8725.0	-55.15	5.1	11.35	Horizontal	-48.90	-13.00	35.90	0
6	10470.0	-52.60	5.3	11.95	Horizontal	-45.95	-13.00	32.95	90
7	12215.0	-53.12	5.5	13.55	Horizontal	-45.07	-13.00	32.07	135
8	13960.0	-50.77	6.3	13.75	Horizontal	-43.32	-13.00	30.32	225
9	15705.0	-51.63	6.7	13.85	Horizontal	-44.48	-13.00	31.48	45
10	17450.0	-48.52	6.8	14.25	Horizontal	-41.07	-13.00	28.07	135

Note: 1. The other Spurious RF Radiated emissions level is no more than noise floor.  
2. The worst emission was found in the antenna is Horizontal position.



## NB-IOT Band 66 CH-High, RB 1

Harmonic	Frequency (MHz)	SG (dBm)	Cable Loss (dB)	Gain (dBi)	Antenna Polarization	EIRP Level (dBm)	Limit (dBm)	Margin (dB)	Azimuth (deg)
2	3559.5	-54.69	2.6	10.15	Horizontal	-47.14	-13.00	34.14	225
3	5261.6	-63.60	2.4	11.05	Horizontal	-54.95	-13.00	41.95	45
4	7017.2	-59.24	4.5	11.15	Horizontal	-52.59	-13.00	39.59	135
5	8771.5	-54.59	5.1	11.35	Horizontal	-48.34	-13.00	35.34	225
6	10525.8	-53.46	5.3	11.95	Horizontal	-46.81	-13.00	33.81	45
7	12280.1	-52.84	5.5	13.55	Horizontal	-44.79	-13.00	31.79	135
8	14034.4	-52.77	6.3	13.75	Horizontal	-45.32	-13.00	32.32	45
9	15788.7	-48.88	6.7	13.85	Horizontal	-41.73	-13.00	28.73	135
10	17543.0	-49.53	6.8	14.25	Horizontal	-42.08	-13.00	29.08	135

Note: 1.The other Spurious RF Radiated emissions level is no more than noise floor.

2. The worst emission was found in the antenna is Horizontal position.

## NB-IOT Band 71 CH-Low, RB 1

Harmonic	Frequency (MHz)	SG (dBm)	Cable Loss (dB)	Gain (dBi)	Antenna Polarization	ERP Level (dBm)	Limit (dBm)	Margin (dB)	Azimuth (deg)
2	1326.0	-45.61	2.00	10.15	Horizontal	-39.61	-13.00	26.61	135
3	1989.0	-44.95	2.50	11.35	Horizontal	-38.25	-13.00	25.25	0
4	2662.0	-60.09	4.20	10.85	Horizontal	-55.59	-13.00	42.59	90
5	3327.5	-64.22	5.20	11.35	Horizontal	-60.22	-13.00	47.22	135
6	3993.0	-62.16	5.50	11.95	Horizontal	-57.86	-13.00	44.86	225
7	4658.5	-60.82	5.70	13.55	Horizontal	-55.12	-13.00	42.12	45
8	5324.0	-58.10	6.30	13.75	Horizontal	-52.80	-13.00	39.80	135
9	5989.5	-58.12	6.80	13.85	Horizontal	-53.22	-13.00	40.22	225
10	6655.0	-56.62	6.90	14.25	Horizontal	-51.42	-13.00	38.42	135

Note: 1.The other Spurious RF Radiated emissions level is no more than noise floor.

2. The worst emission was found in the antenna is Horizontal position.



## NB-IOT Band 71 CH-Middle, RB 1

Harmonic	Frequency (MHz)	SG (dBm)	Cable Loss (dB)	Gain (dBi)	Antenna Polarization	ERP Level (dBm)	Limit (dBm)	Margin (dB)	Azimuth (deg)
2	1361.0	-48.58	2.00	10.75	Horizontal	-41.98	-13.00	28.98	135
3	2041.5	-50.73	2.51	11.05	Horizontal	-44.34	-13.00	31.34	135
4	2722.0	-62.55	4.20	11.15	Horizontal	-57.75	-13.00	44.75	225
5	3402.5	-62.51	5.20	11.15	Horizontal	-58.71	-13.00	45.71	225
6	4083.0	-61.01	5.50	11.95	Horizontal	-56.71	-13.00	43.71	135
7	4763.5	-62.02	5.70	13.55	Horizontal	-56.32	-13.00	43.32	225
8	5444.0	-58.57	6.30	13.75	Horizontal	-53.27	-13.00	40.27	45
9	6124.5	-58.86	6.80	13.85	Horizontal	-53.96	-13.00	40.96	135
10	6805.0	-57.45	6.90	14.25	Horizontal	-52.25	-13.00	39.25	225

Note: 1. The other Spurious RF Radiated emissions level is no more than noise floor.  
2. The worst emission was found in the antenna is Horizontal position.

## NB-IOT Band 71 CH-High, RB 1

Harmonic	Frequency (MHz)	SG (dBm)	Cable Loss (dB)	Gain (dBi)	Antenna Polarization	ERP Level (dBm)	Limit (dBm)	Margin (dB)	Azimuth (deg)
2	1395.3	-47.68	2.00	10.15	Horizontal	-41.68	-13.00	28.68	45
3	2093.5	-51.40	2.51	11.05	Horizontal	-45.01	-13.00	32.01	135
4	2790.0	-61.15	4.20	11.15	Horizontal	-56.35	-13.00	43.35	225
5	3477.5	-60.90	5.20	11.15	Horizontal	-57.10	-13.00	44.10	45
6	4173.0	-60.69	5.50	11.95	Horizontal	-56.39	-13.00	43.39	135
7	4868.5	-61.05	5.70	13.55	Horizontal	-55.35	-13.00	42.35	225
8	5564.0	-59.90	6.30	13.75	Horizontal	-54.60	-13.00	41.60	45
9	6259.5	-57.16	6.80	13.85	Horizontal	-52.26	-13.00	39.26	135
10	6955.0	-54.08	6.90	14.25	Horizontal	-48.88	-13.00	35.88	45

Note: 1. The other Spurious RF Radiated emissions level is no more than noise floor.  
2. The worst emission was found in the antenna is Horizontal position.



## NB-IOT Band 85 CH-Low, RB 1

Harmonic	Frequency (MHz)	SG (dBm)	Cable Loss (dB)	Gain (dBi)	Antenna Polarization	ERP Level (dBm)	Limit (dBm)	Margin (dB)	Azimuth (deg)
2	1396.2	-48.62	2.00	10.15	Horizontal	-42.62	-13.00	29.62	135
3	2094.3	-50.06	2.50	11.35	Horizontal	-43.36	-13.00	30.36	0
4	2792.4	-62.33	4.20	10.85	Horizontal	-57.83	-13.00	44.83	45
5	3490.5	-58.38	5.20	11.35	Horizontal	-54.38	-13.00	41.38	135
6	4188.6	-54.03	5.50	11.95	Horizontal	-49.73	-13.00	36.73	225
7	4886.7	-56.10	5.70	13.55	Horizontal	-50.40	-13.00	37.40	135
8	5584.8	-55.98	6.30	13.75	Horizontal	-50.68	-13.00	37.68	225
9	6282.9	-55.75	6.80	13.85	Horizontal	-50.85	-13.00	37.85	45
10	6981.0	-55.74	6.90	14.25	Horizontal	-50.54	-13.00	37.54	225

Note: 1. The other Spurious RF Radiated emissions level is no more than noise floor.

2. The worst emission was found in the antenna is Horizontal position.

## NB-IOT Band 85 CH-Middle, RB 1

Harmonic	Frequency (MHz)	SG (dBm)	Cable Loss (dB)	Gain (dBi)	Antenna Polarization	ERP Level (dBm)	Limit (dBm)	Margin (dB)	Azimuth (deg)
2	1411.8	-47.40	2.00	10.75	Horizontal	-40.80	-13.00	27.80	270
3	2117.7	-50.69	2.51	11.05	Horizontal	-44.30	-13.00	31.30	0
4	2823.6	-63.50	4.20	11.15	Horizontal	-58.70	-13.00	45.70	270
5	3529.5	-57.88	5.20	11.15	Horizontal	-54.08	-13.00	41.08	45
6	4235.4	-54.47	5.50	11.95	Horizontal	-50.17	-13.00	37.17	135
7	4941.3	-54.97	5.70	13.55	Horizontal	-49.27	-13.00	37.86	135
8	5647.2	-56.16	6.30	13.75	Horizontal	-50.86	-13.00	38.07	45
9	6353.1	-55.97	6.80	13.85	Horizontal	-51.07	-13.00	38.34	135
10	7059.0	-56.54	6.90	14.25	Horizontal	-51.34	-13.00	38.34	0

Note: 1. The other Spurious RF Radiated emissions level is no more than noise floor.

2. The worst emission was found in the antenna is Horizontal position.





## NB-IOT Band 85 CH-High, RB 1

Harmonic	Frequency (MHz)	SG (dBm)	Cable Loss (dB)	Gain (dBi)	Antenna Polarization	ERP Level (dBm)	Limit (dBm)	Margin (dB)	Azimuth (deg)
2	1431.8	-48.25	2.00	10.15	Horizontal	-42.25	-13.00	29.25	45
3	2147.7	-51.62	2.51	11.05	Horizontal	-45.23	-13.00	32.23	135
4	2863.6	-62.34	4.20	11.15	Horizontal	-57.54	-13.00	44.54	0
5	3579.5	-57.24	5.20	11.15	Horizontal	-53.44	-13.00	40.44	90
6	4295.4	-55.47	5.50	11.95	Horizontal	-51.17	-13.00	38.17	135
7	5011.3	-56.05	5.70	13.55	Horizontal	-50.35	-13.00	37.35	45
8	5727.2	-55.84	6.30	13.75	Horizontal	-50.54	-13.00	37.54	270
9	6443.1	-56.30	6.80	13.85	Horizontal	-51.40	-13.00	38.40	315
10	7159.0	-55.90	6.90	14.25	Horizontal	-50.70	-13.00	37.70	0

Note: 1. The other Spurious RF Radiated emissions level is no more than noise floor.

2. The worst emission was found in the antenna is Horizontal position.



## 6 Main Test Instruments

Name	Manufacturer	Type	Serial Number	Calibration Date	Expiration Date
Base Station Simulator	R&S	CMW500	113824	2019-05-19	2020-05-18
Power Splitter	Hua Xiang	SHX-GF2-2-13	10120101	/	/
Spectrum Analyzer	Key sight	N9010A	MY50210259	2019-05-19	2020-05-18
Signal Analyzer	R&S	FSV30	100815	2018-12-16	2019-12-15
Loop Antenna	SCHWARZBECK	FMZB1519	1519-047	2017-09-26	2019-09-25
Trilog Antenna	SCHWARZBECK	VUBL 9163	9163-201	2017-11-18	2019-11-17
Horn Antenna	R&S	HF907	100126	2018-07-07	2020-07-06
Horn Antenna	ETS-Lindgren	3160-09	00102643	2018-06-20	2020-06-19
Signal generator	R&S	SMB 100A	102594	2019-05-19	2020-05-18
Climatic Chamber	ESPEC	SU-242	93000506	2017-12-17	2020-12-16
Preamplifier	R&S	SCU18	102327	2019-05-19	2020-05-18
MOB COMMS DC SUPPLY	Keysight	66319D	MY43004105	2019-05-19	2020-05-18
RF Cable	Agilent	SMA 15cm	0001	2019-06-14	2019-09-13
Software	R&S	EMC32	9.26.0	/	/

\*\*\*\*\*END OF REPORT \*\*\*\*\*

## ANNEX A: EUT Appearance and Test Setup

### A.1 EUT Appearance



Front Side

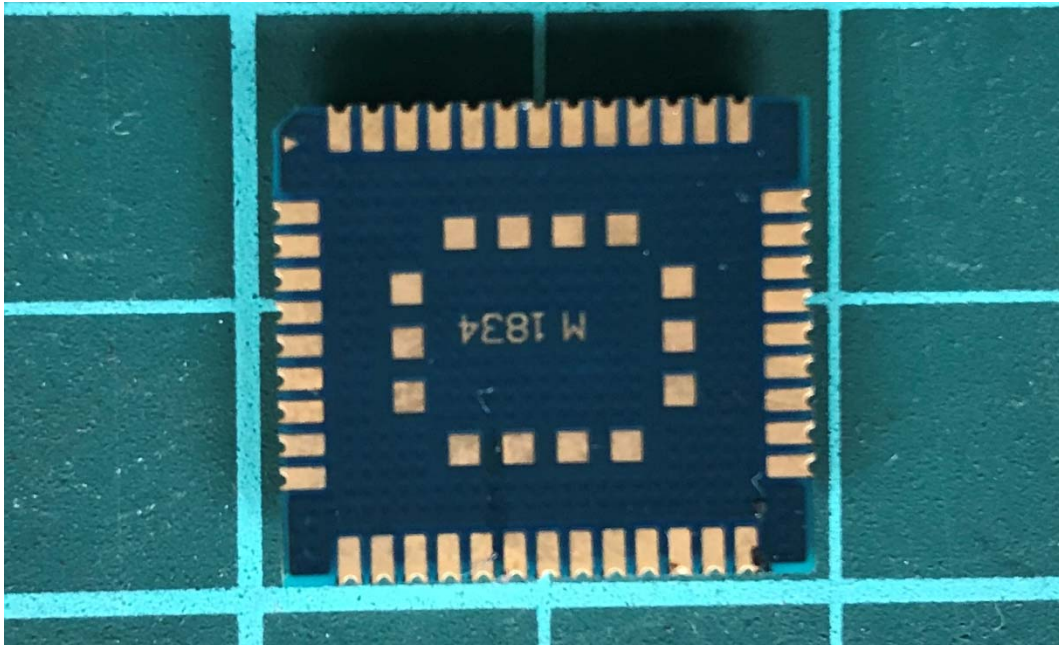

Back Side

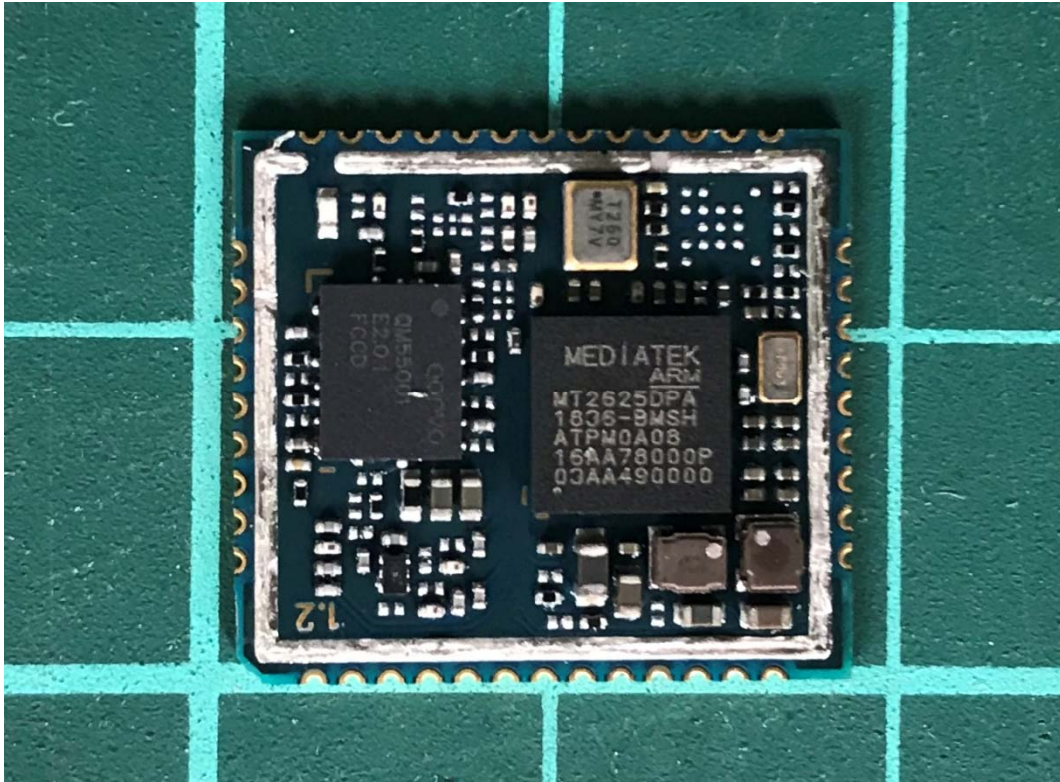

Unshielded

a: EUT

Picture 1 EUT and Accessory

## A.2 Test Setup

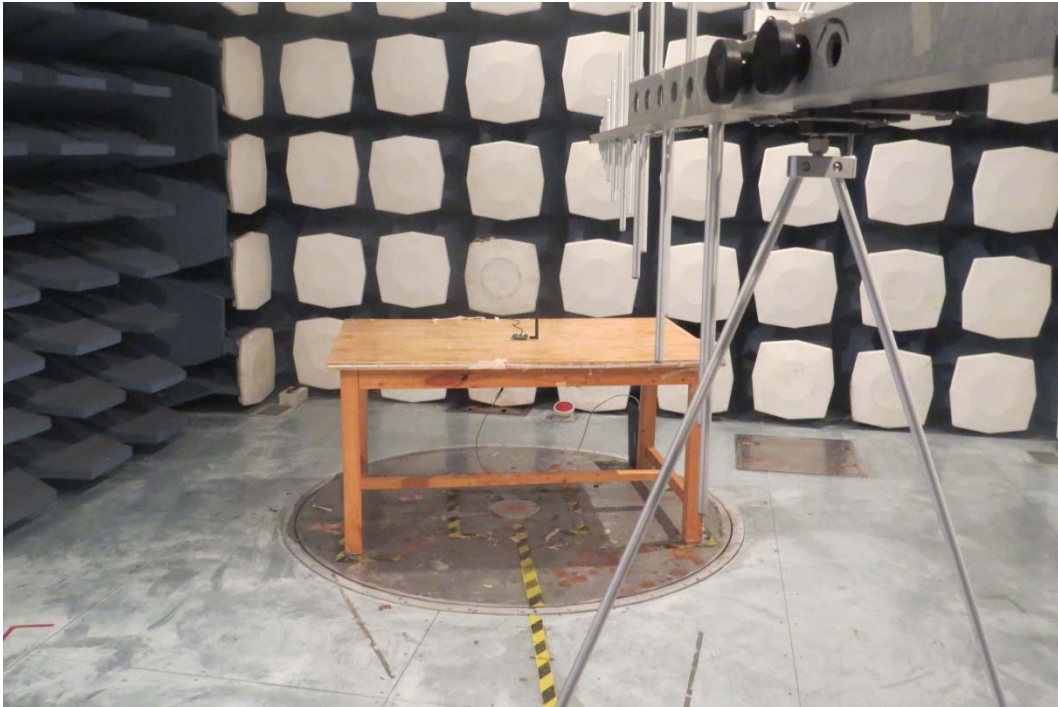

30MHz ~ 1GHz



Above 1GHz

Picture 2 Radiated Spurious Emissions Test setup