



# RF TEST REPORT

<b>Applicant</b>	Quectel Wireless Solutions Company Limited
<b>FCC ID</b>	XMR201708EC25E
<b>Product</b>	LTE Module
<b>Brand</b>	Quectel
<b>Model</b>	EC25-E
<b>Report No.</b>	RXA1707-0251RF02R1
<b>Issue Date</b>	August 17, 2017

TA Technology (Shanghai) Co., Ltd. tested the above equipment in accordance with the requirements in **FCC CFR47 Part 2 (2017)/ FCC CFR47 Part 27C (2017)**. The test results show that the equipment tested is capable of demonstrating compliance with the requirements as documented in this report.

*Jiang peng Lan*

Performed by: Jiangpeng Lan

*Kai Xu*

Approved by: Kai Xu

---

**TA Technology (Shanghai) Co., Ltd.**

No.145, Jintang Rd, Tangzhen Industry Park, Pudong Shanghai, China

TEL: +86-021-50791141/2/3

FAX: +86-021-50791141/2/3-8000

## Table of Contents

<b>1</b>	<b>Test Laboratory</b> .....	4
1.1	Notes of the Test Report .....	4
1.2	Test facility .....	4
1.3	Testing Location .....	5
<b>2</b>	<b>General Description of Equipment under Test</b> .....	6
2.1	Applied Standards .....	7
<b>3</b>	<b>Test Configuration</b> .....	8
<b>4</b>	<b>Test Information</b> .....	9
4.1	RF Power Output .....	9
4.2	Effective Isotropic Radiated Power .....	14
4.3	Occupied Bandwidth .....	20
4.4	Band Edge Compliance .....	31
4.5	Peak-to-Average Power Ratio (PAPR) .....	43
4.6	Frequency Stability .....	46
4.7	Spurious Emissions at Antenna Terminals .....	51
4.8	Radiates Spurious Emission .....	65
<b>5</b>	<b>Main Test Instruments</b> .....	79
<b>ANNEX A: EUT Appearance and Test Setup</b> .....		80
A.1	<b>EUT Appearance</b> .....	80
A.2	<b>Test Setup</b> .....	82

## Summary of Measurement Results

Number	Test Case	Clause in FCC rules	Verdict
1	RF power output	2.1046	PASS
2	Effective Isotropic Radiated power	27.50(h)(2)	PASS
3	Occupied Bandwidth	2.1049	PASS
4	Band Edge Compliance	27.53(m)	PASS
5	Peak-to-Average Power Ratio	27.50(d)/KDB971168 D01(5.7)	PASS
6	Frequency Stability	2.1055 / 27.54	PASS
7	Spurious Emissions at Antenna Terminals	2.1051 /27.53(m)	PASS
8	Radiates Spurious Emission	2.1053 /27.53(m)	PASS
Date of Testing: August 4, 2017 ~ August 9, 2017			
Note: PASS: The EUT complies with the essential requirements in the standard. FAIL: The EUT does not comply with the essential requirements in the standard.			

# 1 Test Laboratory

## 1.1 Notes of the Test Report

This report shall not be reproduced in full or partial, without the written approval of **TA technology (shanghai) co., Ltd.** The results documented in this report apply only to the tested sample, under the conditions and modes of operation as described herein .Measurement Uncertainties were not taken into account and are published for informational purposes only. This report is written to support regulatory compliance of the applicable standards stated above. This report must not be used by the client to claim product certification, approval, or endorsement by any government agencies.

## 1.2 Test facility

### **CNAS (accreditation number: L2264)**

TA Technology (Shanghai) Co., Ltd. has obtained the accreditation of China National Accreditation Service for Conformity Assessment (CNAS).

### **FCC (Designation number: CN1179, Test Firm Registration Number: 446626)**

TA Technology (Shanghai) Co., Ltd. has been listed on the US Federal Communications Commission list of test facilities recognized to perform electromagnetic emissions measurements.

### **IC (recognition number is 8510A)**

TA Technology (Shanghai) Co., Ltd. has been listed by industry Canada to perform electromagnetic emission measurement.

### **VCCI (recognition number is C-4595, T-2154, R-4113, G-10766)**

TA Technology (Shanghai) Co., Ltd. has been listed by industry Japan to perform electromagnetic emission measurement.

### **A2LA (Certificate Number: 3857.01)**

TA Technology (Shanghai) Co., Ltd. has been listed by American Association for Laboratory Accreditation to perform electromagnetic emission measurement.

### 1.3 Testing Location

Company: TA Technology (Shanghai) Co., Ltd.  
Address: No.145, Jintang Rd, Tangzhen Industry Park, Pudong Shanghai, China  
City: Shanghai  
Post code: 201201  
Country: P. R. China  
Contact: Xu Kai  
Telephone: +86-021-50791141/2/3  
Fax: +86-021-50791141/2/3-8000  
Website: <http://www.ta-shanghai.com>  
E-mail: [xukai@ta-shanghai.com](mailto:xukai@ta-shanghai.com)

## 2 General Description of Equipment under Test

### Client Information

<b>Applicant</b>	Quectel Wireless Solutions Company Limited
<b>Applicant address</b>	7th Floor, Hongye Building, No.1801 Hongmei Road, Xuhui District, Shanghai 200233, China
<b>Manufacturer</b>	Quectel Wireless Solutions Company Limited
<b>Manufacturer address</b>	7th Floor, Hongye Building, No.1801 Hongmei Road, Xuhui District, Shanghai 200233, China

### General information

EUT Description			
Model:	EC25-E		
SN	/		
Hardware Version	R1.0		
Software Version	EC25EFAR02A07M4G		
Power Supply:	External power supply		
Antenna Type:	The EUT don't have standard Antenna, The Antenna used for testing in this report is the after-market accessory (Dipole Antenna)		
Test Mode(s):	LTE Band 7/41		
LTE Release	11 (Don't support CA)		
Maximum E.I.R.P.	LTE Band 7:	25.74dBm	
	LTE Band 41:	26.30dBm	
Rated Power Supply Voltage:	3.8V		
Extreme Voltage:	Minimum: 3.3V    Maximum: 4.3V		
Extreme Temperature:	Lowest:-40°C    Highest: +85°C		
Operating Frequency Range(s)	Mode	Tx (MHz)	Rx (MHz)
	LTE Band 7	2500 ~ 2570	2620 ~ 2690
	LTE Band 41	2555 ~ 2655	2555 ~ 2655
Note: 1. The information of the EUT is declared by the manufacturer.			

Accessory equipment	
Evaluation Board	RF Cable
RS232-to-USB Cable	Antenna: Dipole Antenna
Headset	USB Cable

## 2.1 Applied Standards

According to the specifications of the manufacturer, it must comply with the requirements of the following standards:

### Test standards

**FCC CFR47 Part 2 (2017)**

**FCC CFR47 Part 27C (2017)**

**ANSI C63.26 (2015)**

**KDB 971168 D01 Power Meas License Digital Systems v02r02**

### 3 Test Configuration

Radiated measurements are performed by rotating the EUT in three different orthogonal test planes. EUT stand-up position (Z axis), lie-down position (X, Y axis). Receiver antenna polarization (horizontal and vertical), the worst emission was found in position (Z axis, vertical polarization) and the worst case was recorded.

All mode and data rates and positions and RB size and modulations were investigated.

Subsequently, only the worst case emissions are reported.

The following testing in LTE is set based on the maximum RF Output Power.

The following testing in different Bandwidth is set to detail in the following table:

Test modes are chosen to be reported as the worst case configuration below for LTE Band 7/41

Test items	Bandwidth (MHz)				Modulation		RB			Test Channel		
	5	10	15	20	QPSK	16QAM	1	50%	100%	L	M	H
RF power output	O	O	O	O	O	O	O	O	O	O	O	O
Effective Isotropic Radiated power	O	O	O	O	O	O	-	-	O	O	O	O
Occupied Bandwidth	O	O	O	O	O	O	-	-	O	O	O	O
Band Edge Compliance	O	O	O	O	O	O	O	-	O	O	-	O
Peak-to-Average Power Ratio	O	O	O	O	O	O	-	-	O	O	O	O
Frequency Stability	O	O	O	O	O	O	-	-	O	-	O	-
Spurious Emissions at Antenna Terminals	O	O	O	O	O	-	O	-	-	O	O	O
Radiates Spurious Emission	O	O	O	O	O	-	O	-	-	O	O	O
Note	1. The mark "O" means that this configuration is chosen for testing. 2. The mark "-" means that this configuration is not testing.											



## 4 Test Information

### 4.1 RF Power Output

#### Ambient condition

Temperature	Relative humidity	Pressure
23°C ~25°C	45%~50%	101.5kPa

#### Methods of Measurement

During the process of the testing, The EUT is controlled by the Base Station Simulator to ensure max power transmission and proper modulation.

#### Test Setup

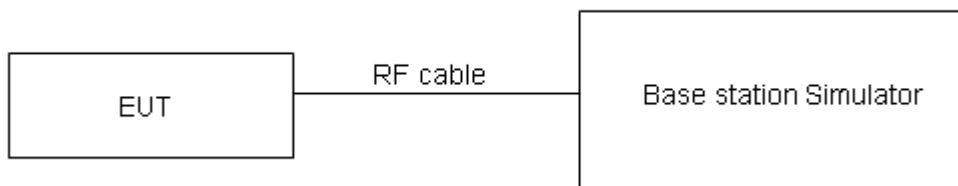

The loss between RF output port of the EUT and the input port of the tester has been taken into consideration.

#### Limits

No specific RF power output requirements in part 2.1046.

#### Measurement Uncertainty

The assessed measurement uncertainty to ensure 95% confidence level for the normal distribution is with the coverage factor  $k = 2$ ,  $U=0.4$  dB.

**Test Results**

LTE FDD Band 7				Conducted Power(dBm)		
Bandwidth	Modulation	RB size	RB offset	Channel/Frequency (MHz)		
				20775/2502.5	21100/2535	21425/2567.5
5MHz	QPSK	1	0	23.00	22.60	22.55
		1	13	22.31	22.97	22.57
		1	24	22.11	22.04	22.25
		12	0	21.45	21.86	21.67
		12	6	21.26	21.92	21.66
		12	13	21.21	21.56	21.35
		25	0	21.18	21.76	21.56
	16QAM	1	0	22.60	21.91	21.72
		1	13	21.86	22.35	21.57
		1	24	21.51	21.56	20.96
		12	0	20.82	20.99	20.28
		12	6	20.65	20.52	20.46
		12	13	20.58	20.77	20.38
		25	0	20.59	20.69	20.51
Bandwidth	Modulation	RB size	RB offset	Channel/Frequency (MHz)		
				20800/2505	21100/2535	21400/2565
10MHz	QPSK	1	0	23.02	22.61	22.58
		1	25	22.34	23.02	22.61
		1	49	22.13	22.08	22.28
		25	0	21.48	21.91	21.71
		25	13	21.29	21.97	21.70
		25	25	21.23	21.60	21.40
		50	0	21.26	21.78	21.60
	16QAM	1	0	22.62	21.94	21.74
		1	25	21.89	22.39	21.60
		1	49	21.54	21.58	20.99
		25	0	20.85	21.04	20.32
		25	13	20.67	20.56	20.49
		25	25	20.61	20.82	20.42
		50	0	20.62	20.74	20.55
Bandwidth	Modulation	RB size	RB offset	Channel/Frequency (MHz)		
				20825/2507.5	21100/2535	21375/2562.5
15MHz	QPSK	1	0	23.01	22.57	22.56
		1	38	22.32	23.01	22.58
		1	74	22.10	22.03	22.24
		36	0	21.46	21.87	21.68
		36	18	21.26	21.92	21.66



Bandwidth	Modulation	RB size	RB offset	Channel/Frequency (MHz)		
				20850/2510	21100/2535	21350/2560
20MHz	16QAM	36	39	21.20	21.57	21.36
		75	0	21.24	21.74	21.55
		1	0	22.57	21.92	21.72
		1	38	21.87	22.36	21.58
		1	74	21.51	21.54	20.96
		36	0	20.82	21.02	20.29
		36	18	20.64	20.51	20.45
		36	39	20.59	20.78	20.39
	75	0	20.59	20.69	20.51	
	QPSK	1	0	22.98	22.53	22.53
		1	50	22.31	22.97	22.56
		1	99	22.08	22.02	22.21
		50	0	21.43	21.82	21.64
		50	25	21.24	21.88	21.63
		50	50	21.17	21.52	21.32
		100	0	21.21	21.69	21.51
16QAM		1	0	22.55	21.88	21.67
	1	50	21.83	22.34	21.54	
	1	99	21.49	21.51	20.94	
	50	0	20.79	20.98	20.26	
	50	25	20.61	20.49	20.42	
	50	50	20.56	20.73	20.35	
100	0	20.57	20.65	20.48		

LTE TDD Band 41				AV Conducted Power(dBm)		
Bandwidth	Modulation	RB size	RB offset	Channel/Frequency (MHz)		
				40265/2557.5	40740/2605	41215/2652.5
5MHz	QPSK	1	0	23.19	23.16	23.36
		1	13	23.20	23.27	23.36
		1	24	23.25	22.87	23.30
		12	0	22.21	22.35	23.28
		12	6	22.16	22.28	22.28
		12	13	22.22	22.32	22.35
		25	0	22.08	22.24	22.28
	16QAM	1	0	22.39	22.30	21.80
		1	13	22.52	22.46	21.92
		1	24	22.52	21.94	21.72
		12	0	21.22	21.29	21.20
		12	6	21.25	21.26	21.39
		12	13	21.29	21.13	21.41



Bandwidth	Modulation	RB size	RB offset	Channel/Frequency (MHz)		
				40290/2560	40740/2605	41190/2650
				25	0	21.18
10MHz	QPSK	1	0	23.21	23.17	23.39
		1	25	23.23	23.32	23.40
		1	49	23.27	22.91	23.33
		25	0	22.24	22.40	23.32
		25	13	22.19	22.33	22.32
		25	25	22.24	22.36	22.40
		50	0	22.16	22.26	22.32
	16QAM	1	0	22.41	22.33	21.82
		1	25	22.55	22.50	21.95
		1	49	22.55	21.96	21.75
		25	0	21.25	21.34	21.24
		25	13	21.27	21.30	21.42
		25	25	21.32	21.18	21.45
		50	0	21.21	21.34	21.35
Bandwidth	Modulation	RB size	RB offset	Channel/Frequency (MHz)		
				40315/2562.5	40740/2605	41165/2647.5
				1	0	23.20
15MHz	QPSK	1	38	23.21	23.31	23.37
		1	74	23.24	22.86	23.29
		36	0	22.22	22.36	23.29
		36	18	22.16	22.28	22.28
		36	39	22.21	22.33	22.36
		75	0	22.14	22.22	22.27
		16QAM	1	0	22.36	22.31
	1		38	22.53	22.47	21.93
	1		74	22.52	21.92	21.72
	36		0	21.22	21.32	21.21
	36		18	21.24	21.25	21.38
	36		39	21.30	21.14	21.42
	75		0	21.18	21.29	21.31
	Bandwidth	Modulation	RB size	RB offset	Channel/Frequency (MHz)	
40340/2565					40740/2605	41140/2645
1					0	23.17
20MHz	QPSK	1	50	23.20	23.27	23.35
		1	99	23.22	22.85	23.26
		50	0	22.19	22.31	23.25
		50	25	22.14	22.24	22.25



		50	50	22.18	22.28	22.32
		100	0	22.11	22.17	22.23
	16QAM	1	0	22.34	22.27	21.75
		1	50	22.49	22.45	21.89
		1	99	22.50	21.89	21.70
		50	0	21.19	21.28	21.18
		50	25	21.21	21.23	21.35
		50	50	21.27	21.09	21.38
		100	0	21.16	21.25	21.28

## 4.2 Effective Isotropic Radiated Power

### Ambient condition

Temperature	Relative humidity	Pressure
23°C ~25°C	45%~50%	101.5kPa

### Methods of Measurement

1. The testing follows ANSI C63.26 (2015) Section 5.5.2.3.
2. Above 30MHz: The EUT is placed on a turntable 0.8 meters above the ground in the chamber, 3 meter away from the antenna. The maximal emission value is acquired by adjusting the antenna height, polarisation and turntable azimuth. Normally, the height range of antenna is 1 m to 4 m, the azimuth range of turntable is 0° to 360°, and the receive antenna has two polarizations Vertical (V) and Horizontal (H). Above 1GHz: (Note: the FCC's permission to use 1.5m as an alternative per TCBC Conf call of Dec. 2, 2014.) The EUT is placed on a turntable 1.5 meters above the ground in the chamber, 3 meter away from the antenna. The maximal emission value is acquired by adjusting the antenna height, polarisation and turntable azimuth. Normally, the height range of antenna is 1 m to 4 m, the azimuth range of turntable is 0° to 360°, and the receive antenna has two polarizations Vertical (V) and Horizontal (H).
3. A log-periodic antenna or double-ridged waveguide horn antenna shall be substituted in place of the EUT. The log-periodic antenna will be driven by a signal generator and the level will be adjusted till the same power value on the spectrum analyzer or receiver. The level of the spurious emissions can be calculated through the level of the signal generator, cable loss, the gain of the substitution antenna and the reading of the spectrum analyzer or receiver.
4. The EUT is then put into continuously transmitting mode at its maximum power level during the test. Set Test Receiver or Spectrum RBW=1MHz, VBW=3MHz, And the maximum value of the receiver should be recorded as (Pr).
5. The EUT shall be replaced by a substitution antenna. In the chamber, an substitution antenna for the frequency band of interest is placed at the reference point of the chamber. An RF Signal source for the frequency band of interest is connected to the substitution antenna with a cable that has been constructed to not interfere with the radiation pattern of the antenna. A power (PMea) is applied to the input of the substitution antenna, and adjust the level of the signal generator output until the value of the receiver reach the previously recorded (Pr). The power of signal source (PMea) is recorded. The test should be performed by rotating the test item and adjusting the receiving antenna polarization.
6. A amplifier should be connected to the Signal Source output port. And the cable should be connect between the Amplifier and the Substitution Antenna. The cable loss (Pcl) ,the Substitution Antenna Gain (Ga) and the Amplifier Gain (PAg) should be recorded after test.
7. The measurement results are obtained as described below:  

$$\text{Power(EIRP)} = \text{PMea} - \text{PAg} - \text{Pcl} + \text{Ga}$$
 The measurement results are amend as described below:  

$$\text{Power(EIRP)} = \text{PMea} - \text{Pcl} + \text{Ga}$$
8. This value is EIRP since the measurement is calibrated using an antenna of known gain (2.15 dBi) and known input power. ERP can be calculated from EIRP by subtracting the gain of the dipole,  $\text{ERP} = \text{EIRP} - 2.15\text{dBi}$ .

**Test setup**

**30MHz~~~ 1GHz**

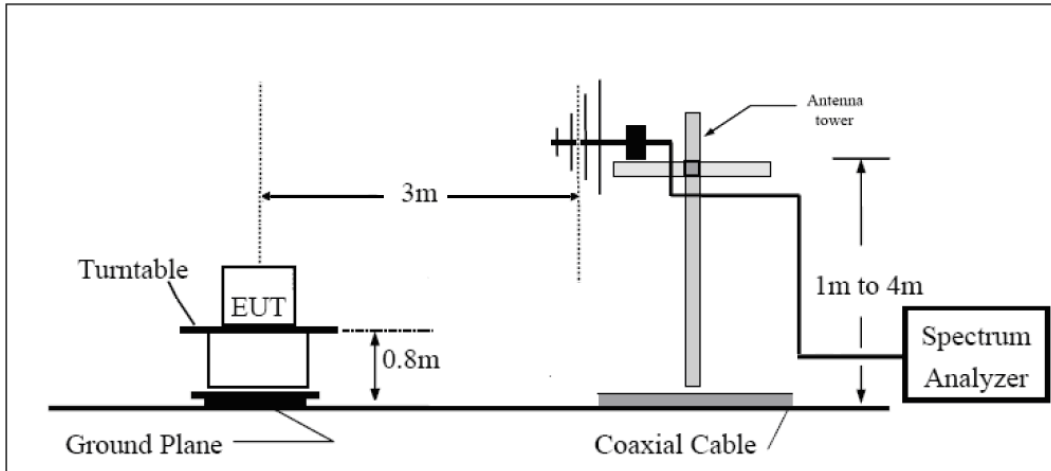

**Above 1GHz**

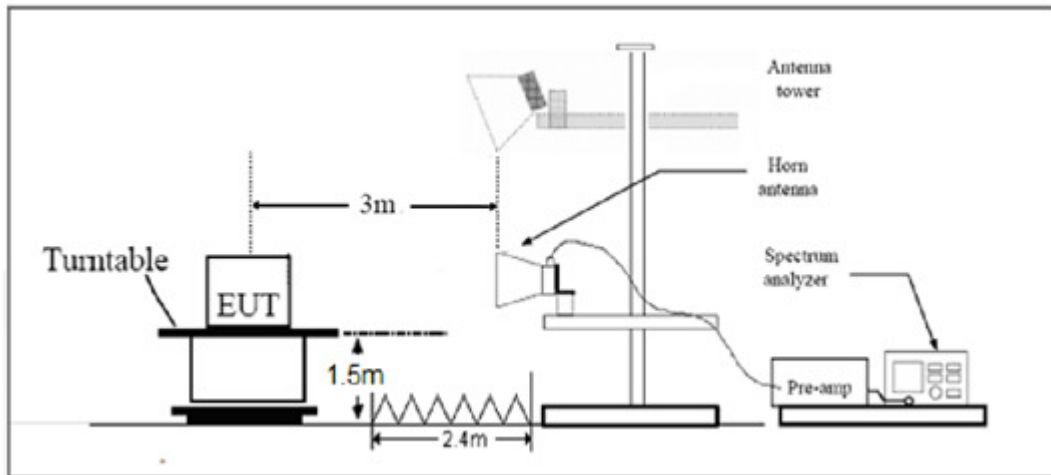

Note: Area side:2.4mX3.6m

The radiated emission was measured in the following position: EUT stand-up position (Z axis), lie-down position (X, Y axis). The worst emission was found in stand-up position (Z axis) and the worst case was recorded.

**Limits**

Rule Part 27.50(h) (2) specifies that “Mobile and other user stations. Mobile stations are limited to 2.0 watts EIRP. All user stations are limited to 2.0 watts transmitter output power.”

Part 27.50(h)(2) Limit (EIRP)	$\leq 2 \text{ W}$ (33 dBm)
-------------------------------	-----------------------------

**Measurement Uncertainty**

The assessed measurement uncertainty to ensure 95% confidence level for the normal distribution is with the coverage factor  $k = 2$ ,  $U = 1.19 \text{ dB}$



**Test Results**

LTE Band 7								
Band width	Frequency (MHz)	Ant Pot (H/V)	Rt (dBm)	Rs (dBm)	Ps (dBm)	Gs (dBi)	EIRP (dBm)	Conclusion
5MHz (QPSK)	2502.5	H	-35.71	-59.64	0.00	1.81	25.74	Pass
	2535	H	-35.88	-59.72	0.00	1.81	25.65	Pass
	2567.5	H	-36.68	-59.98	0.00	1.83	25.13	Pass
	2502.5	V	-37.98	-59.31	0.00	1.81	23.14	Pass
	2535	V	-38.07	-59.11	0.00	1.81	22.85	Pass
	2567.5	V	-39.56	-59.59	0.00	1.83	21.86	Pass
5MHz (16QAM)	2502.5	H	-36.01	-59.64	0.00	1.81	25.44	Pass
	2535	H	-36.21	-59.72	0.00	1.81	25.32	Pass
	2567.5	H	-36.99	-59.98	0.00	1.83	24.82	Pass
	2502.5	V	-38.32	-59.31	0.00	1.81	22.80	Pass
	2535	V	-38.37	-59.11	0.00	1.81	22.55	Pass
	2567.5	V	-39.87	-59.59	0.00	1.83	21.55	Pass
10MHz (QPSK)	2505	H	-36.55	-59.61	0.00	1.82	24.88	Pass
	2535	H	-36.53	-59.72	0.00	1.81	25.00	Pass
	2565	H	-37.35	-60.02	0.00	1.81	24.48	Pass
	2505	V	-38.70	-59.33	0.00	1.82	22.45	Pass
	2535	V	-38.64	-59.11	0.00	1.81	22.28	Pass
	2565	V	-39.86	-59.59	0.00	1.81	21.54	Pass
10MHz (16QAM)	2505	H	-36.86	-59.61	0.00	1.82	24.57	Pass
	2535	H	-36.83	-59.72	0.00	1.81	24.70	Pass
	2565	H	-37.68	-60.02	0.00	1.81	24.15	Pass
	2505	V	-39.00	-59.33	0.00	1.82	22.15	Pass
	2535	V	-38.94	-59.11	0.00	1.81	21.98	Pass
	2565	V	-40.17	-59.59	0.00	1.81	21.23	Pass
15MHz (QPSK)	2507.5	H	-41.58	-59.71	0.00	1.80	19.93	Pass
	2535	H	-44.43	-59.72	0.00	1.81	17.10	Pass
	2562.5	H	-45.51	-60.08	0.00	1.82	16.39	Pass
	2507.5	V	-46.03	-59.29	0.00	1.80	15.06	Pass
	2535	V	-47.23	-59.72	0.00	1.81	14.30	Pass
	2562.5	V	-47.98	-59.46	0.00	1.82	13.30	Pass
15MHz (16QAM)	2507.5	H	-41.88	-59.71	0.00	1.80	19.63	Pass
	2535	H	-44.73	-59.72	0.00	1.81	16.80	Pass
	2562.5	H	-45.82	-60.08	0.00	1.82	16.08	Pass
	2507.5	V	-46.33	-59.29	0.00	1.80	14.76	Pass
	2535	V	-47.53	-59.72	0.00	1.81	14.00	Pass
	2562.5	V	-48.28	-59.46	0.00	1.82	13.00	Pass
20MHz (QPSK)	2510	H	-41.78	-59.52	0.00	1.77	19.51	Pass
	2535	H	-44.85	-59.72	0.00	1.81	16.68	Pass
	2560	H	-45.86	-60.01	0.00	1.82	15.97	Pass



	2510	V	-46.22	-59.09	0.00	1.77	14.64	Pass
	2535	V	-47.65	-59.72	0.00	1.81	13.88	Pass
	2560	V	-48.46	-59.52	0.00	1.82	12.88	Pass
20MHz (16QAM)	2510	H	-42.08	-59.52	0.00	1.77	19.21	Pass
	2535	H	-45.15	-59.72	0.00	1.81	16.38	Pass
	2560	H	-46.17	-60.01	0.00	1.82	15.66	Pass
	2510	V	-46.52	-59.09	0.00	1.77	14.34	Pass
	2535	V	-47.95	-59.72	0.00	1.81	13.58	Pass
	2560	V	-48.76	-59.52	0.00	1.82	12.58	Pass

LTE Band 41								
Band width	Frequency (MHz)	Ant Pot (H/V)	Rt (dBm)	Rs (dBm)	Ps (dBm)	Gs (dBi)	EIRP (dBm)	Conclusion
5MHz (QPSK)	2557.5	H	-35.67	-59.90	0.00	1.69	25.91	Pass
	2605	H	-35.60	-59.98	0.00	1.69	26.06	Pass
	2652.5	H	-35.71	-60.24	0.00	1.71	26.23	Pass
	2557.5	V	-40.70	-59.57	0.00	1.69	20.55	Pass
	2605	V	-37.76	-59.37	0.00	1.69	23.29	Pass
	2652.5	V	-39.03	-59.85	0.00	1.71	22.52	Pass
5MHz (16QAM)	2557.5	H	-35.98	-59.90	0.00	1.69	25.60	Pass
	2605	H	-35.91	-59.98	0.00	1.69	25.75	Pass
	2652.5	H	-36.02	-60.24	0.00	1.71	25.92	Pass
	2557.5	V	-40.95	-59.57	0.00	1.69	20.30	Pass
	2605	V	-38.05	-59.37	0.00	1.69	23.00	Pass
	2652.5	V	-39.34	-59.85	0.00	1.71	22.21	Pass
10MHz (QPSK)	2560	H	-35.51	-59.87	0.00	1.70	26.05	Pass
	2605	H	-35.56	-59.98	0.00	1.69	26.10	Pass
	2650	H	-35.71	-60.28	0.00	1.69	26.25	Pass
	2560	V	-38.71	-59.59	0.00	1.70	22.57	Pass
	2605	V	-37.78	-59.37	0.00	1.69	23.27	Pass
	2650	V	-38.83	-59.85	0.00	1.69	22.70	Pass
10MHz (16QAM)	2560	H	-35.81	-59.87	0.00	1.70	25.75	Pass
	2605	H	-35.86	-59.98	0.00	1.69	25.80	Pass
	2650	H	-36.03	-60.28	0.00	1.69	25.93	Pass
	2560	V	-39.03	-59.59	0.00	1.70	22.25	Pass
	2605	V	-38.10	-59.37	0.00	1.69	22.95	Pass
	2650	V	-39.14	-59.85	0.00	1.69	22.39	Pass
15MHz (QPSK)	2562.5	H	-37.42	-59.97	0.00	1.68	24.22	Pass
	2605	H	-36.59	-59.98	0.00	1.69	25.07	Pass
	2647.5	H	-38.23	-60.34	0.00	1.70	23.80	Pass
	2562.5	V	-35.64	-59.55	0.00	1.68	25.58	Pass
	2605	V	-35.36	-59.98	0.00	1.69	26.30	Pass
	2647.5	V	-35.33	-59.72	0.00	1.70	26.08	Pass



15MHz (16QAM)	2562.5	H	-37.72	-59.97	0.00	1.68	23.92	Pass
	2605	H	-36.91	-59.98	0.00	1.69	24.75	Pass
	2647.5	H	-38.53	-60.34	0.00	1.70	23.50	Pass
	2562.5	V	-35.95	-59.55	0.00	1.68	25.27	Pass
	2605	V	-35.66	-59.98	0.00	1.69	26.00	Pass
	2647.5	V	-35.66	-59.72	0.00	1.70	25.75	Pass
20MHz (QPSK)	2565	H	-35.97	-59.78	0.00	1.65	25.45	Pass
	2605	H	-37.12	-59.98	0.00	1.69	24.54	Pass
	2645	H	-36.75	-60.27	0.00	1.70	25.21	Pass
	2565	V	-38.50	-59.35	0.00	1.65	22.49	Pass
	2605	V	-35.67	-59.98	0.00	1.69	25.99	Pass
	2645	V	-35.41	-59.78	0.00	1.70	26.06	Pass
20MHz (16QAM)	2565	H	-36.27	-59.78	0.00	1.65	25.15	Pass
	2605	H	-37.42	-59.98	0.00	1.69	24.24	Pass
	2645	H	-37.06	-60.27	0.00	1.70	24.90	Pass
	2565	V	-38.81	-59.35	0.00	1.65	22.18	Pass
	2605	V	-35.98	-59.98	0.00	1.69	25.68	Pass
	2645	V	-35.72	-59.78	0.00	1.70	25.75	Pass

Note: 1. EIRP= E.R.P+2.15

### 4.3 Occupied Bandwidth

#### Ambient condition

Temperature	Relative humidity	Pressure
23°C ~25°C	45%~50%	101.5kPa

#### Method of Measurement

The EUT was connected to Spectrum Analyzer and Base Station Simulator via power Splitter. The occupied bandwidth is measured using spectrum analyzer.

RBW is set to 100 kHz, VBW is set to 300 kHz for LTE Band 7/41 (5MHz).

RBW is set to 300 kHz, VBW is set to 1MHz for LTE Band 7/41 (10MHz/15MHz/20MHz).

99% power and -26dBc occupied bandwidths are recorded. Spectrum analyzer plots are included on the following pages.

#### Test Setup

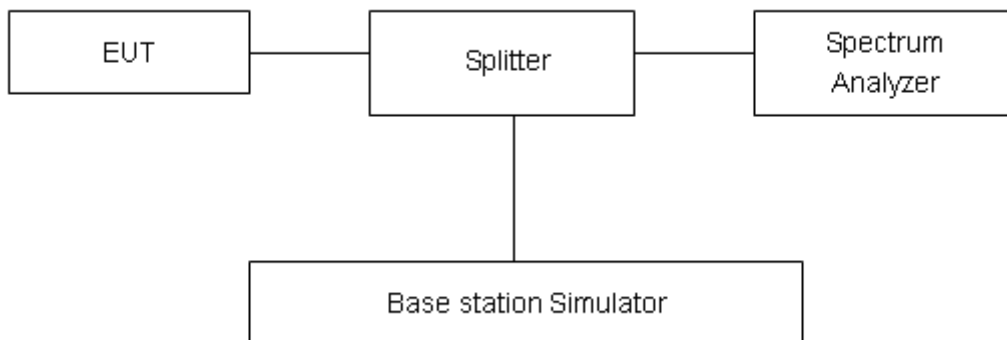

#### Limits

No specific occupied bandwidth requirements in part 2.1049.

#### Measurement Uncertainty

The assessed measurement uncertainty to ensure 95% confidence level for the normal distribution is with the coverage factor  $k = 2$ ,  $U=624\text{Hz}$ .

**Test Result**

LTE Band 7						
RB	Modulation	Bandwidth (MHz)	Channel	Frequency (MHz)	99% Power Bandwidth(MHz)	-26dBc Bandwidth(MHz)
100%	QPSK	5	20775	2502.5	4.5329	5.006
			21100	2535	4.0588	4.991
			21425	2567.5	4.5087	4.992
		10	20800	2505	9.0426	9.998
			21100	2535	9.041	10.04
			21400	2565	9.0164	10.01
		15	20825	2507.5	13.47	14.76
			21100	2535	13.429	14.68
			21375	2562.5	13.441	14.71
		20	20850	2510	17.847	19.15
			21100	2535	17.852	19.31
			21350	2560	17.855	19.35
	16QAM	5	20775	2502.5	4.5018	5.034
			21100	2535	4.5356	5.028
			21425	2567.5	4.53	5.036
		10	20800	2505	9.0426	9.998
			21100	2535	9.041	10.04
			21400	2565	9.0164	10.01
		15	20825	2507.5	13.47	14.76
			21100	2535	13.429	14.68
			21375	2562.5	13.441	14.71
		20	20850	2510	17.847	19.15
			21100	2535	17.852	19.31
			21350	2560	17.855	19.35



LTE Band 41						
RB	Modulation	Bandwidth (MHz)	Channel	Frequency (MHz)	99% Power Bandwidth(MHz)	-26dBc Bandwidth(MHz)
100%	QPSK	5	40265	2557.5	4.5055	5.306
			40740	2605	4.5115	5.282
			41215	2652.5	4.5008	5.22
		10	40290	2560	9.0629	10.31
			40740	2605	9.0603	10.63
			41190	2650	9.0512	10.08
		15	40315	2562.5	13.511	15.36
			40740	2605	13.52	15.6
			41165	2647.5	13.466	15.1
		20	40340	2565	17.85	19.61
			40740	2605	17.861	19.47
			41140	2645	17.817	19.39
	16QAM	5	40265	2557.5	4.5108	4.953
			40740	2605	4.5059	5.006
			41215	2652.5	4.5009	4.994
		10	40290	2560	8.9967	9.975
			40740	2605	9.0151	10.42
			41190	2650	8.9938	9.945
		15	40315	2562.5	13.478	15.21
			40740	2605	13.483	15.22
			41165	2647.5	13.423	15.12
		20	40340	2565	17.866	19.3
			40740	2605	17.877	19.59
			41140	2645	17.864	19.37

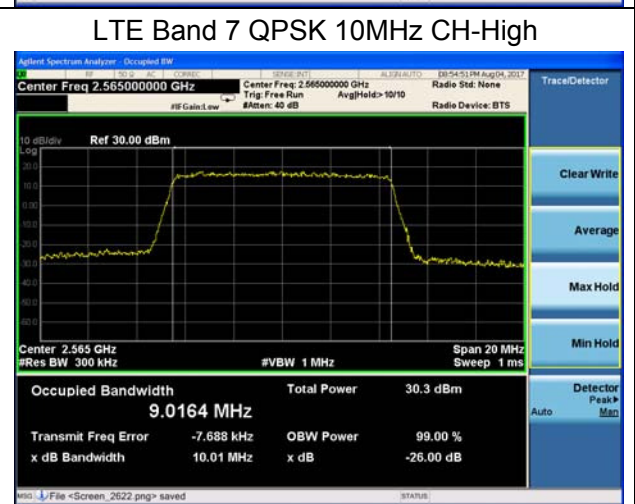
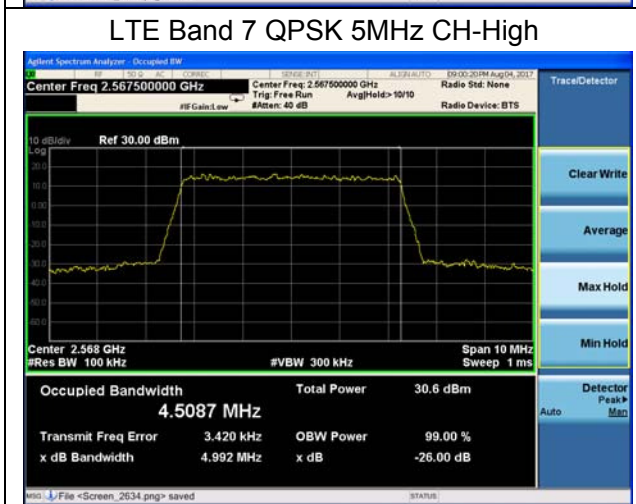
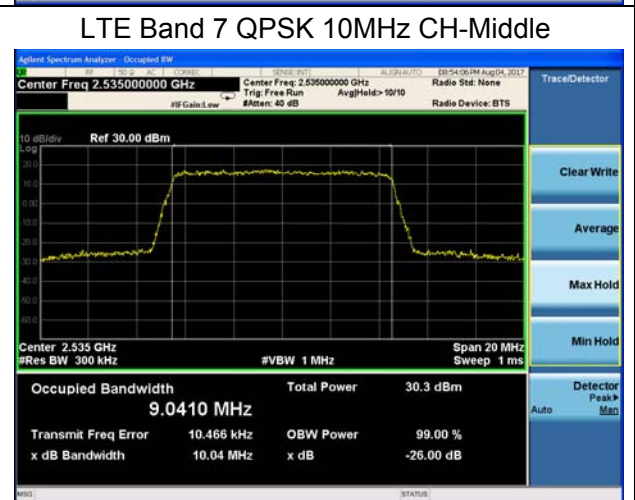
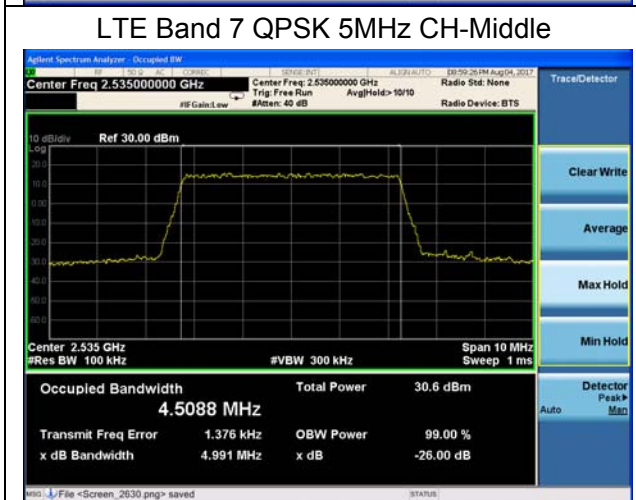
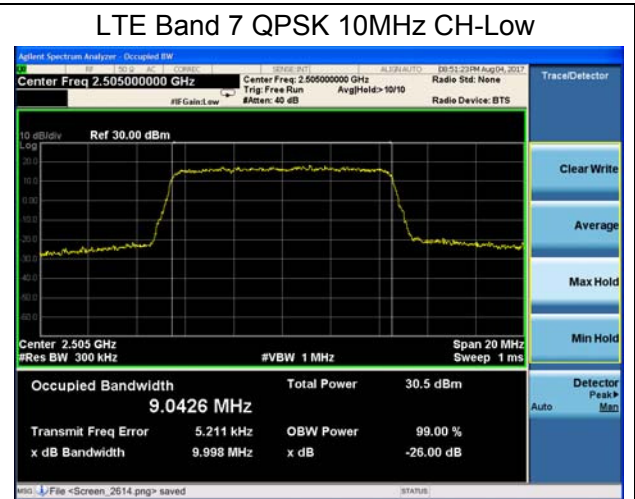
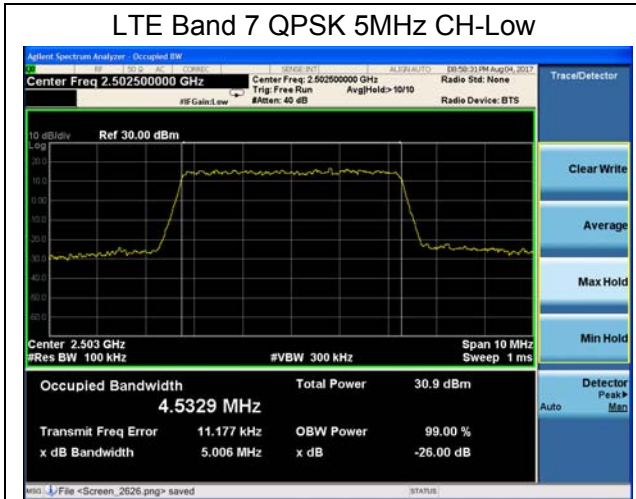

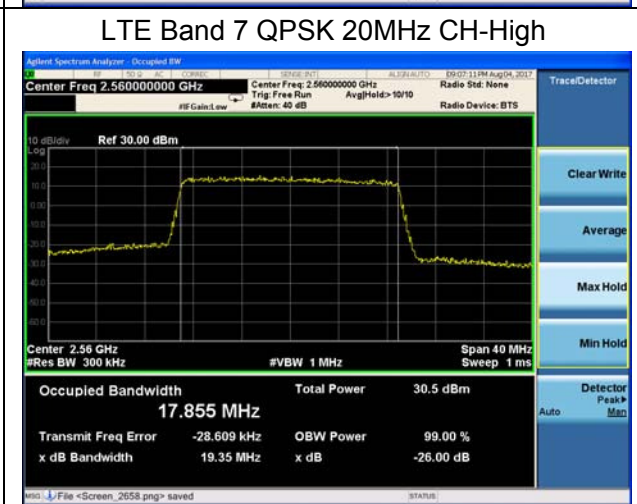
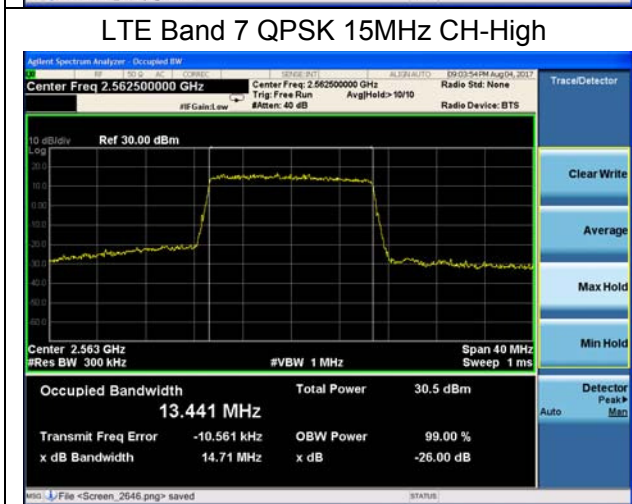
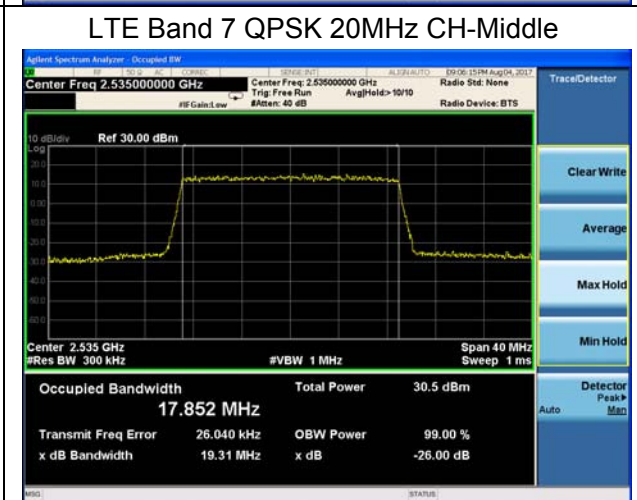
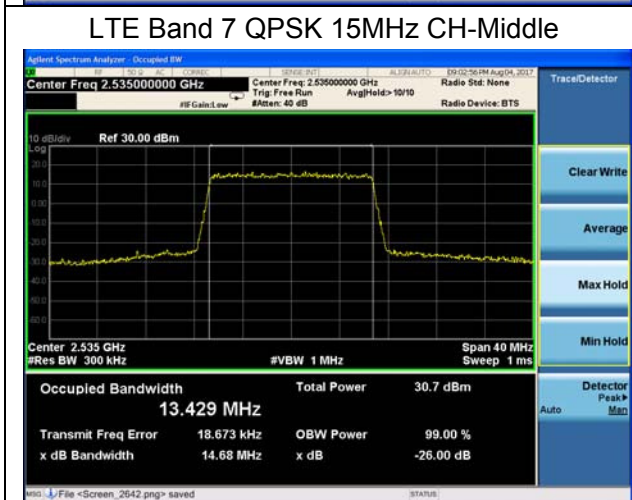
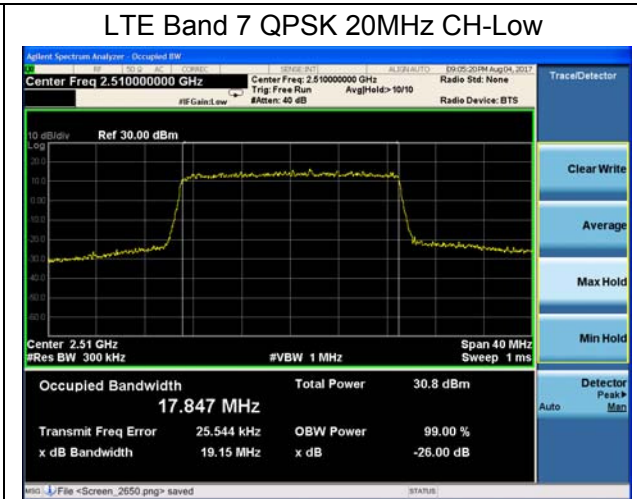
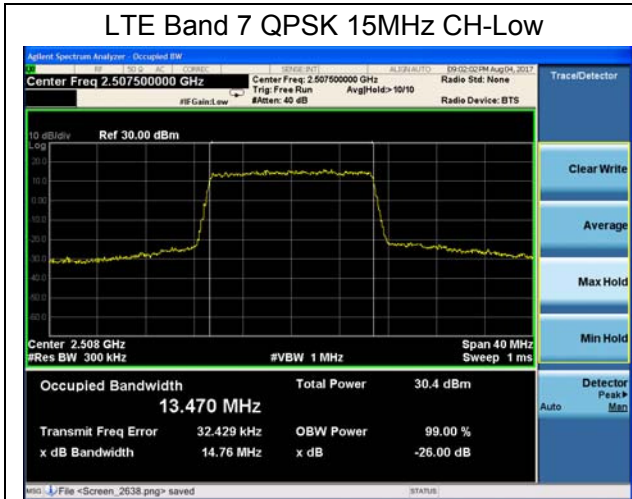



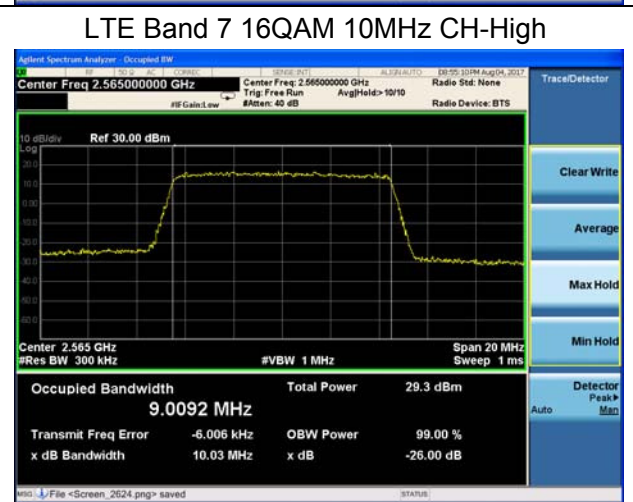
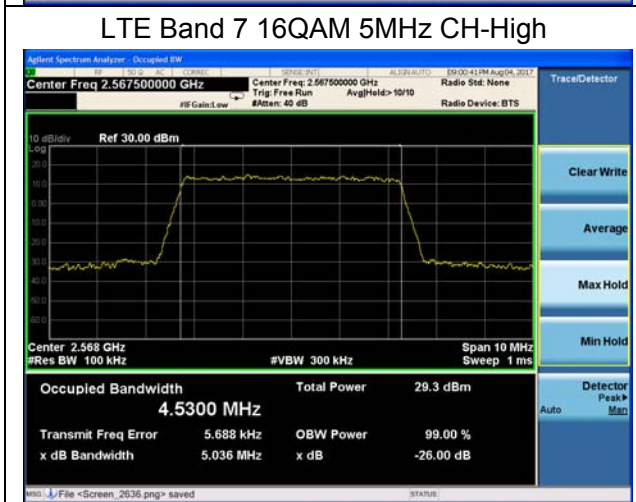
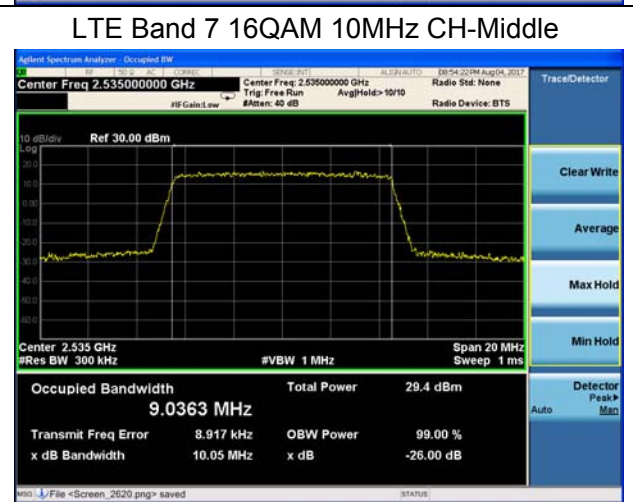
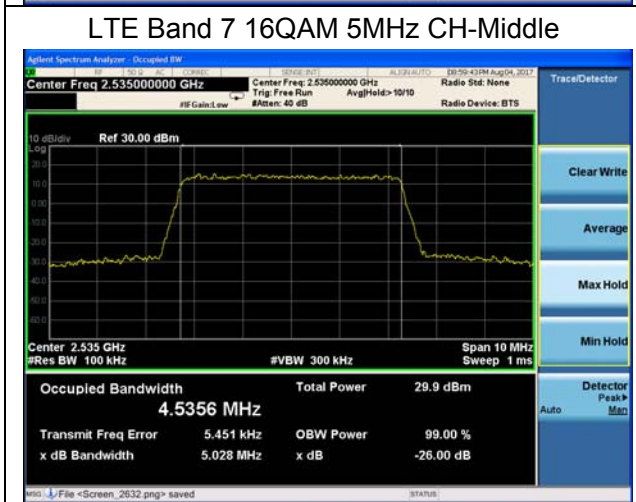
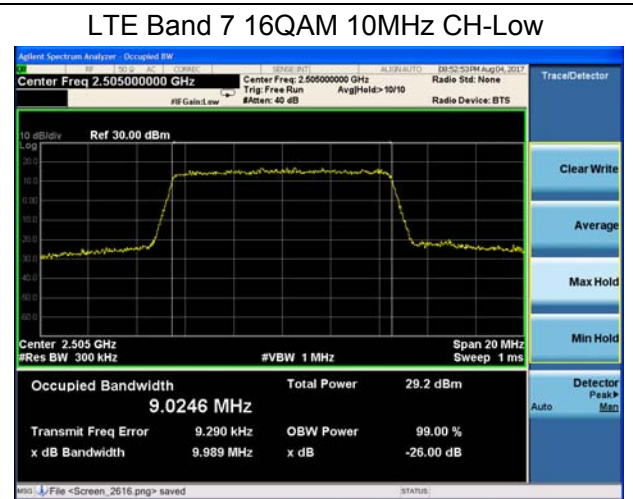
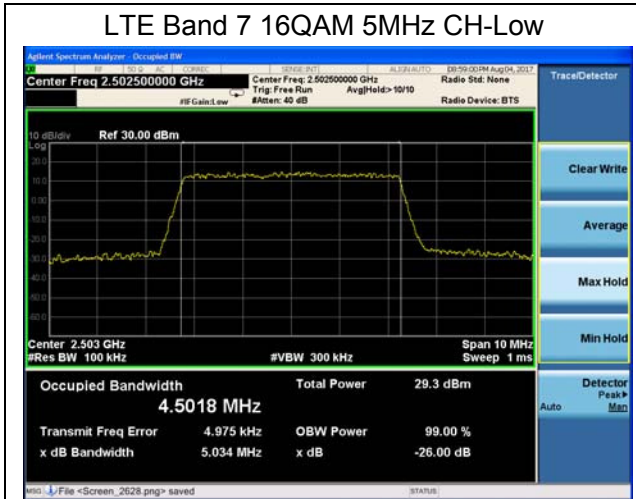



### LTE Band 7 16QAM 15MHz CH-Low

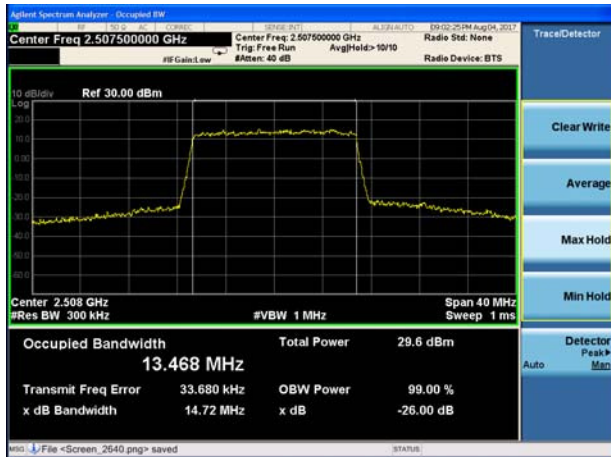

### LTE Band 7 16QAM 20MHz CH-Low

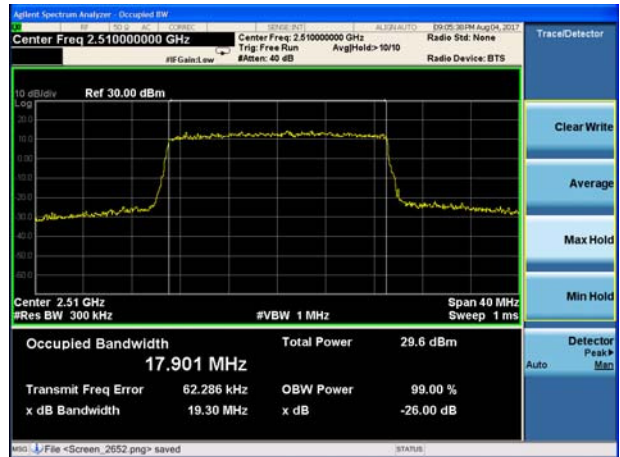

### LTE Band 7 16QAM 15MHz CH-Middle

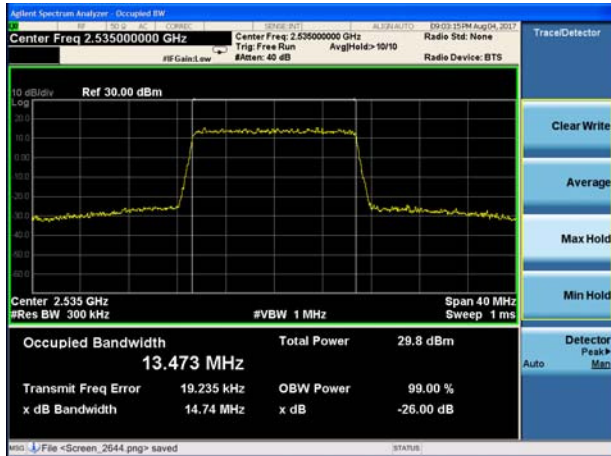

### LTE Band 7 16QAM 20MHz CH-Middle

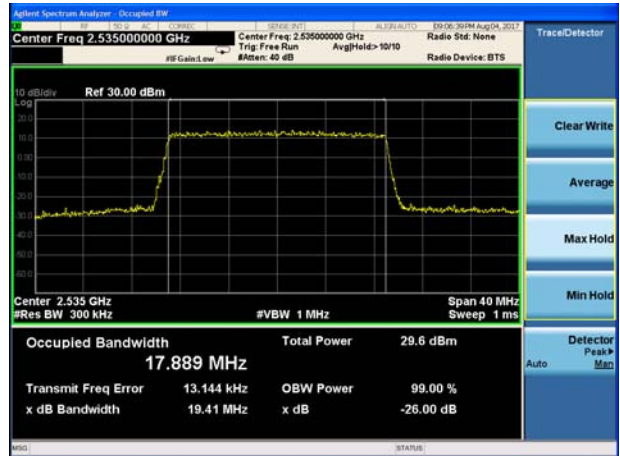

### LTE Band 7 16QAM 15MHz CH-High

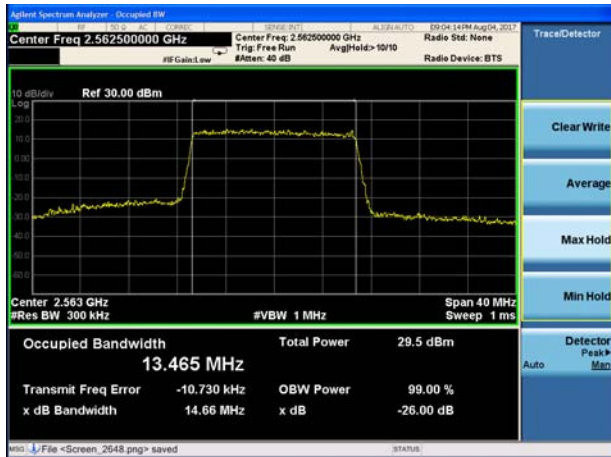

### LTE Band 7 16QAM 20MHz CH-High

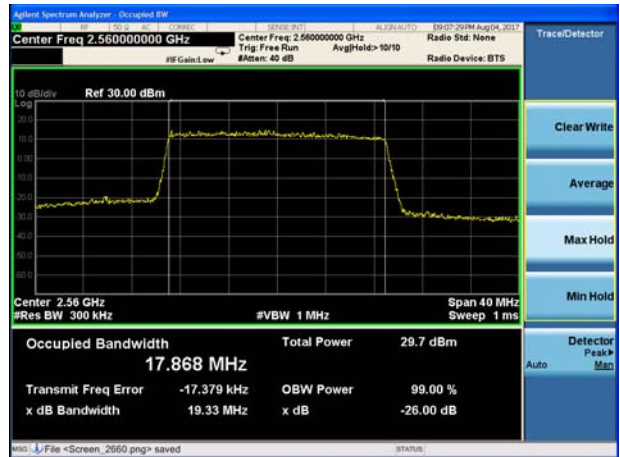

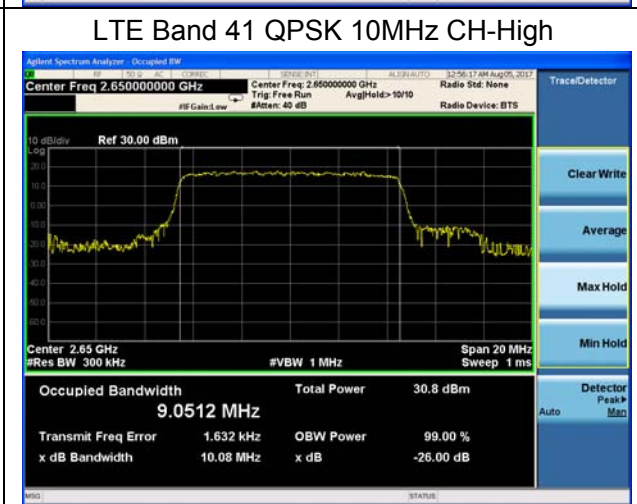
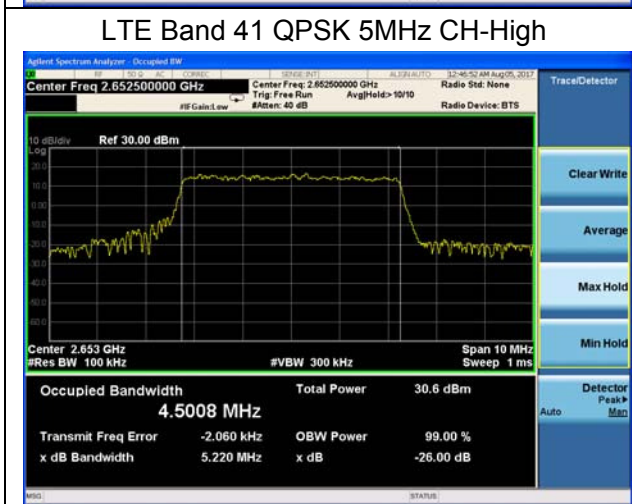
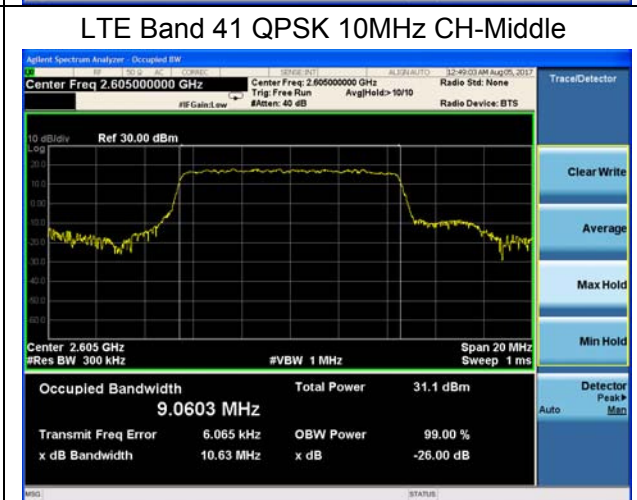
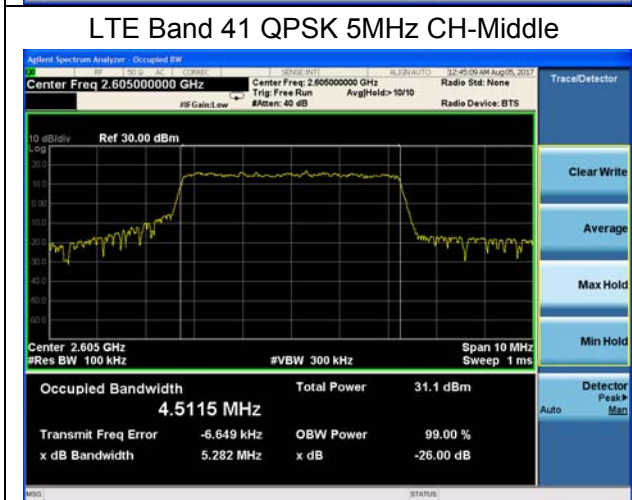
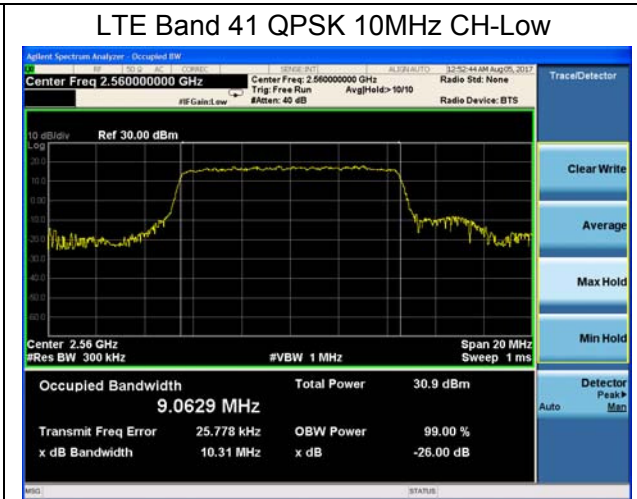
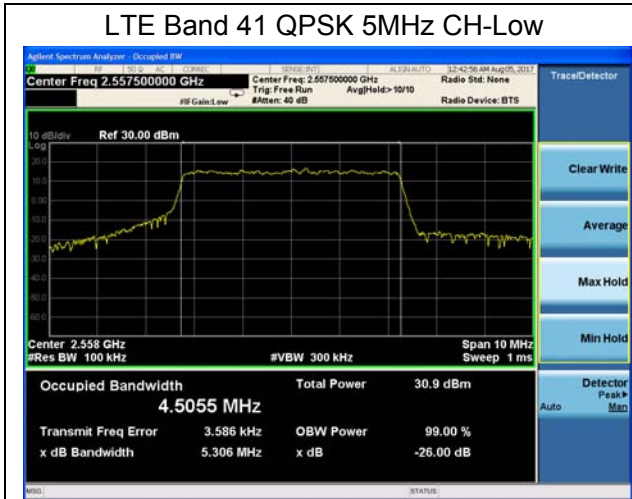



LTE Band 41 QPSK 15MHz CH-Low

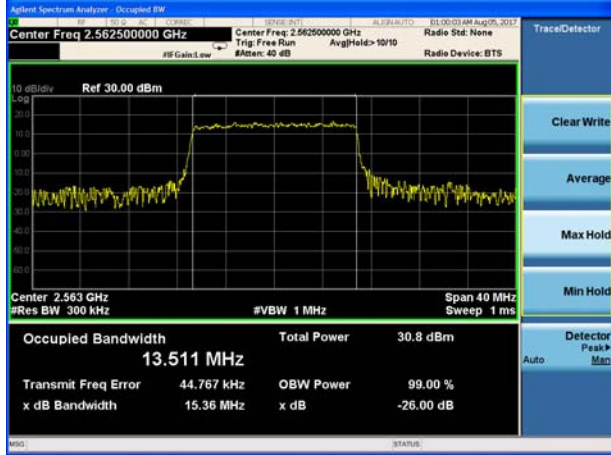

LTE Band 41 QPSK 20MHz CH-Low

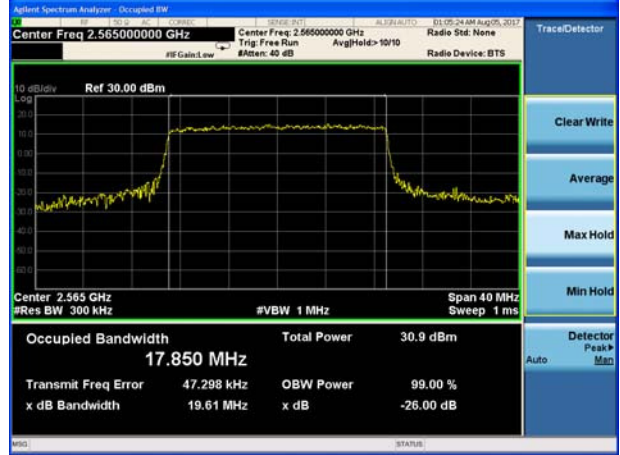

LTE Band 41 QPSK 15MHz CH-Middle

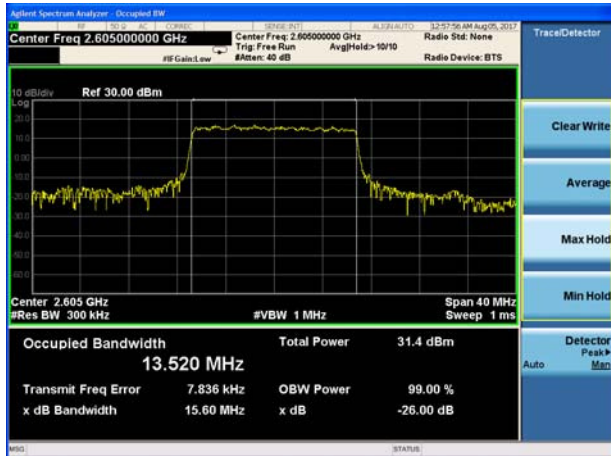

LTE Band 41 QPSK 20MHz CH-Middle

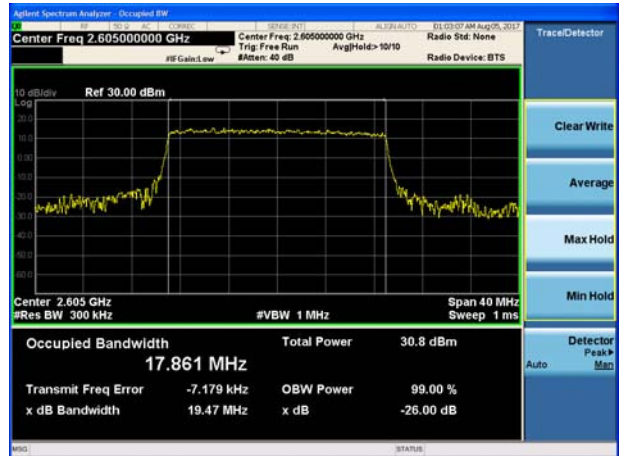

LTE Band 41 QPSK 15MHz CH-High

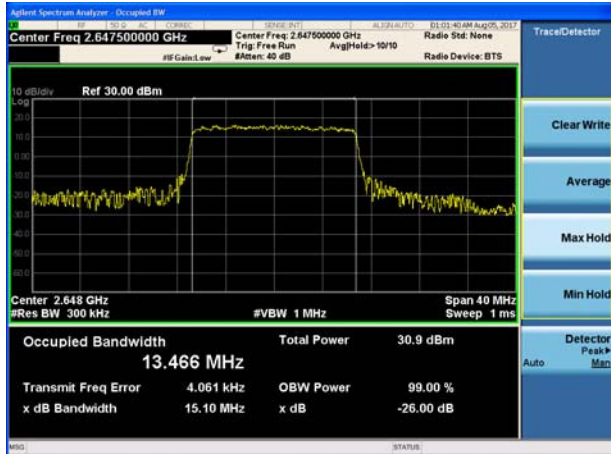

LTE Band 41 QPSK 20MHz CH-High

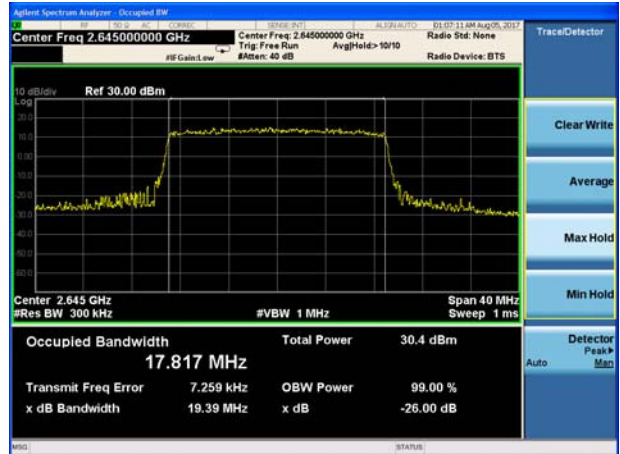



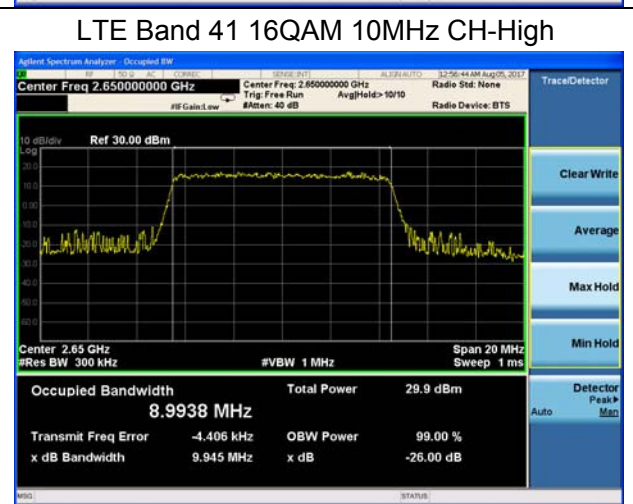
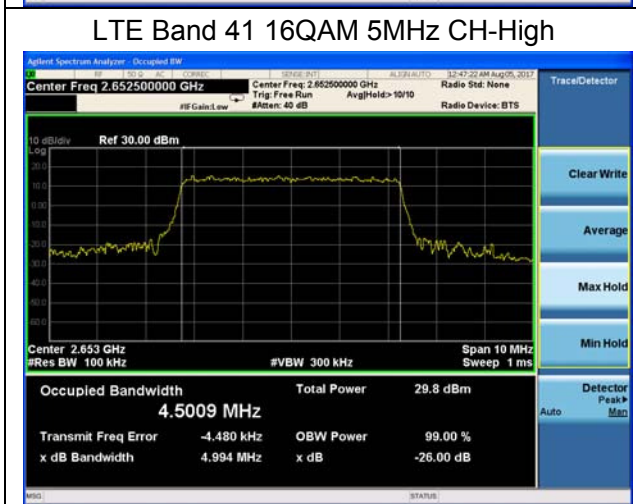
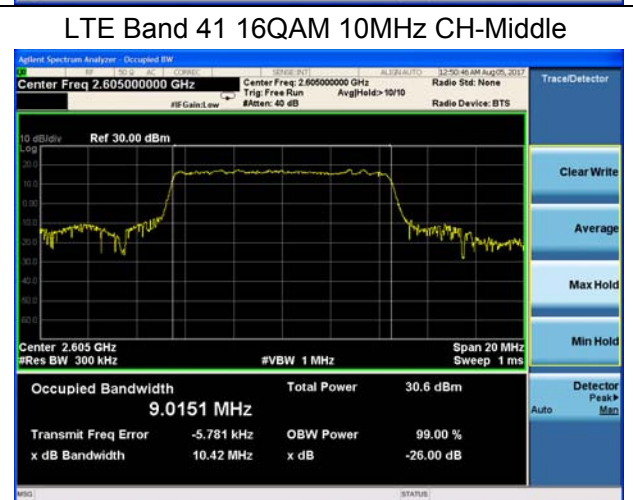
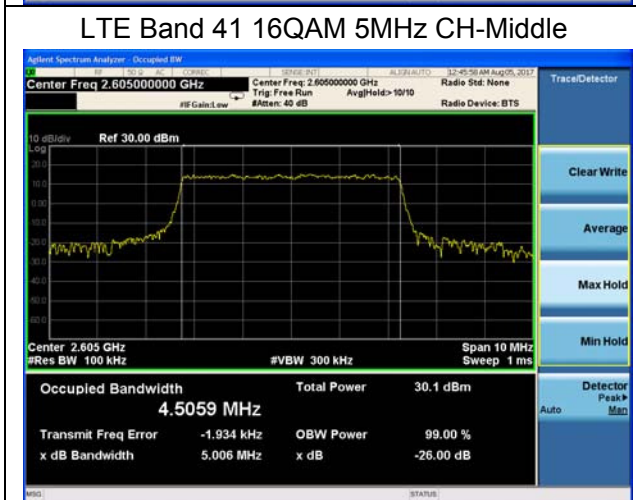
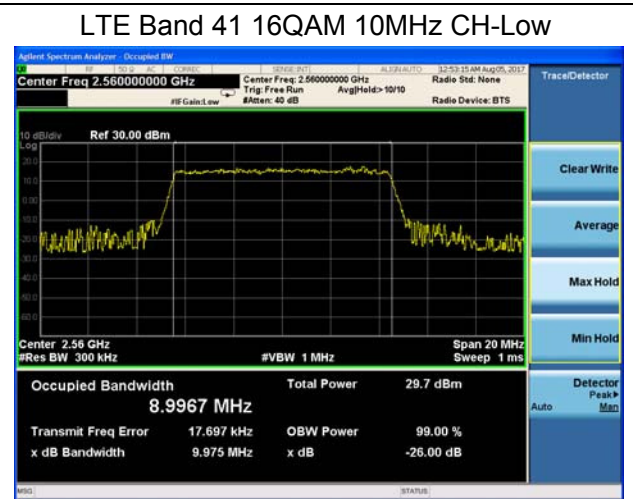
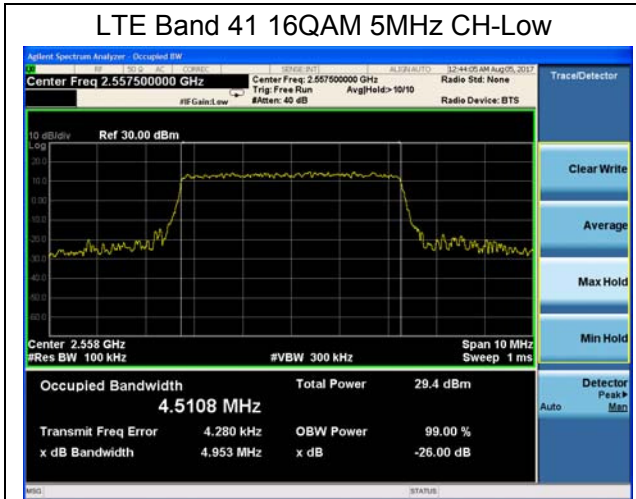

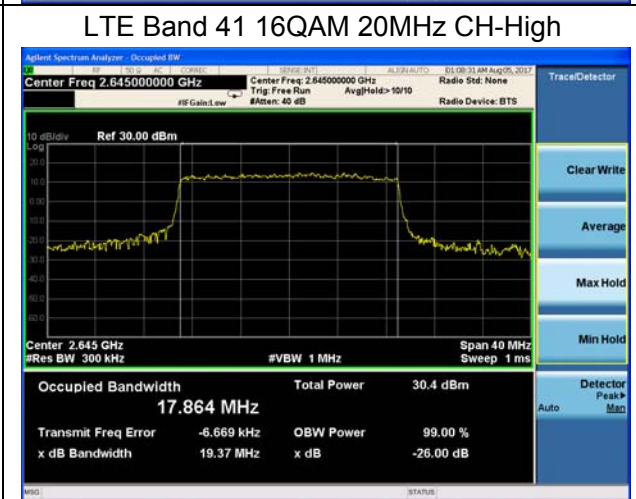
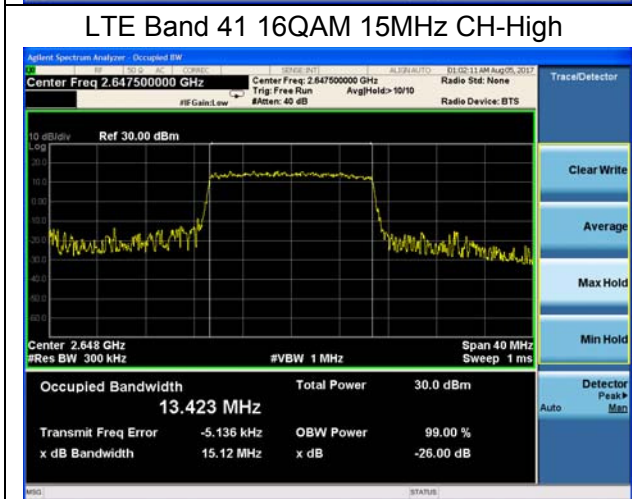
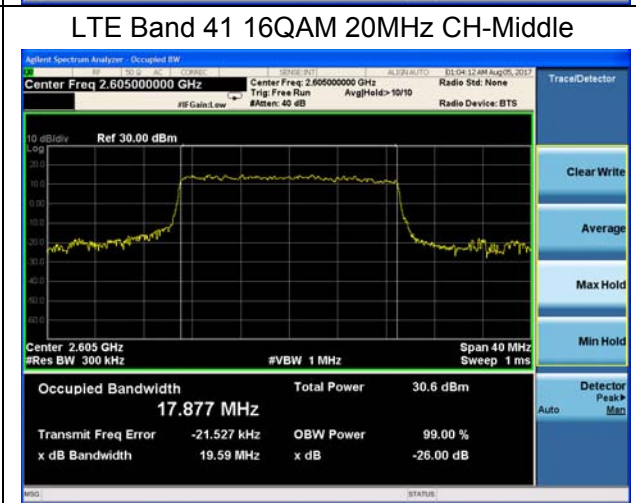
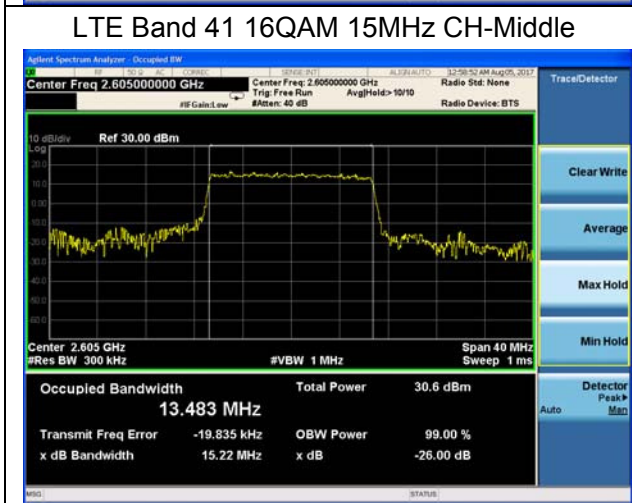
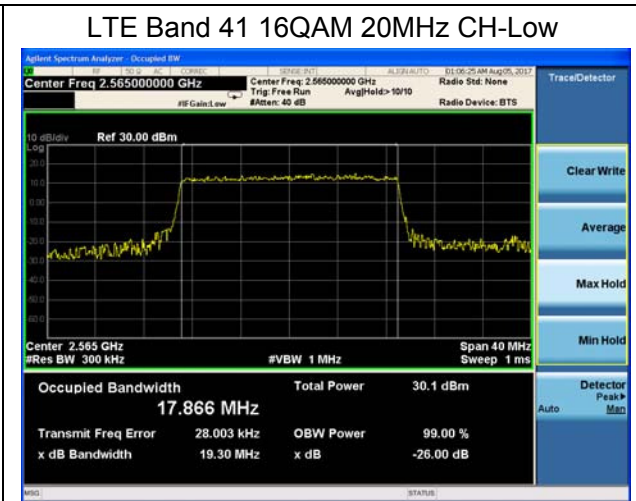
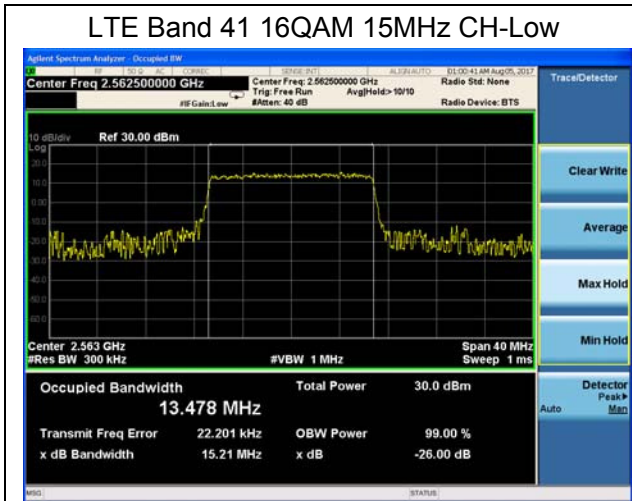

### 4.4 Band Edge Compliance

#### Ambient condition

Temperature	Relative humidity	Pressure
23°C ~25°C	45%~50%	101.5kPa

#### Method of Measurement

The EUT was connected to Spectrum Analyzer and Base Station Simulator via power Splitter. The band edge of the lowest and highest channels were measured.

The testing follows KDB 971168 v02r02 Section 6.0

- 1.The EUT was connected to spectrum analyzer and system simulator via a power divider.
2. The band edges of low and high channels for the highest RF powers were measured.
3. For LTE Band 41 Set RBW >= 1% EBW in the 1MHz band immediately outside and adjacent to the band edge. Beyond the 1 MHz band from the band edge, RBW=1MHz was used. RBW is set to 51 kHz, VBW is set to 160 kHz for LTE Band 7(5MHz). RBW is set to 100 kHz, VBW is set to 300kHz for LTE Band 7 (10MHz). RBW is set to 150 kHz, VBW is set to 510 kHz for LTE Band 7 (15MHz). RBW is set to 200 kHz, VBW is set to 620 kHz for LTE Band 7(20MHz) on spectrum analyzer.
4. Set spectrum analyzer with RMS detector.
5. The RF fundamental frequency should be excluded against the limit line in the operating frequency band.
6. Checked that all the results comply with the emission limit line.

#### Test Setup

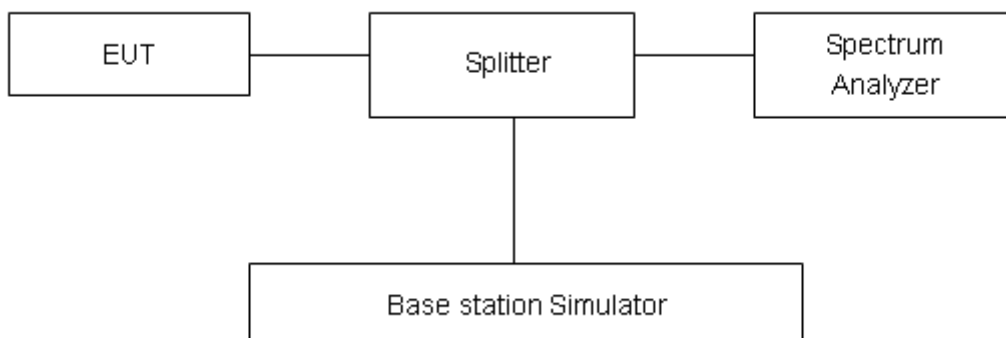

## Limits

Part 27.53(m) (4) specifies that “for BRS and EBS stations. For mobile digital stations, the attenuation factor shall be not less than  $40 + 10 \log (P)$  dB on all frequencies between the channel edge and 5 megahertz from the channel edge,  $43 + 10 \log (P)$  dB on all frequencies between 5 megahertz and X megahertz from the channel edge, and  $55 + 10 \log (P)$  dB on all frequencies more than X megahertz from the channel edge, where X is the greater of 6 megahertz or the actual emission bandwidth as defined in paragraph (m)(4) of this section. In addition, the attenuation factor shall not be less that  $43 + 10 \log (P)$  dB on all frequencies between 2490.5 MHz and 2496 MHz and  $55 + 10 \log (P)$  dB at or below 2490.5 MHz. Mobile Satellite Service licensees operating on frequencies below 2495 MHz may also submit a documented interference complaint against BRS licensees operating on channel BRS Channel 1 on the same terms and conditions as adjacent channel BRS or EBS licensees.

Example:

The limit line is derived from  $43 + 10 \log (P)$  dB below the transmitter power P(Watts)

$$= P(W) - [43 + 10 \log(P)] \text{ (dB)}$$

$$= [30 + 10 \log (P)] \text{ (dBm)} - [43 + 10 \log(P)] \text{ (dB)} = -13 \text{ dBm.}$$

## Measurement Uncertainty

The assessed measurement uncertainty to ensure 95% confidence level for the normal distribution is with the coverage factor  $k = 1.96$ ,  $U=0.684$ dB.



**Test Result**

All the test traces in the plots shows the test results clearly.

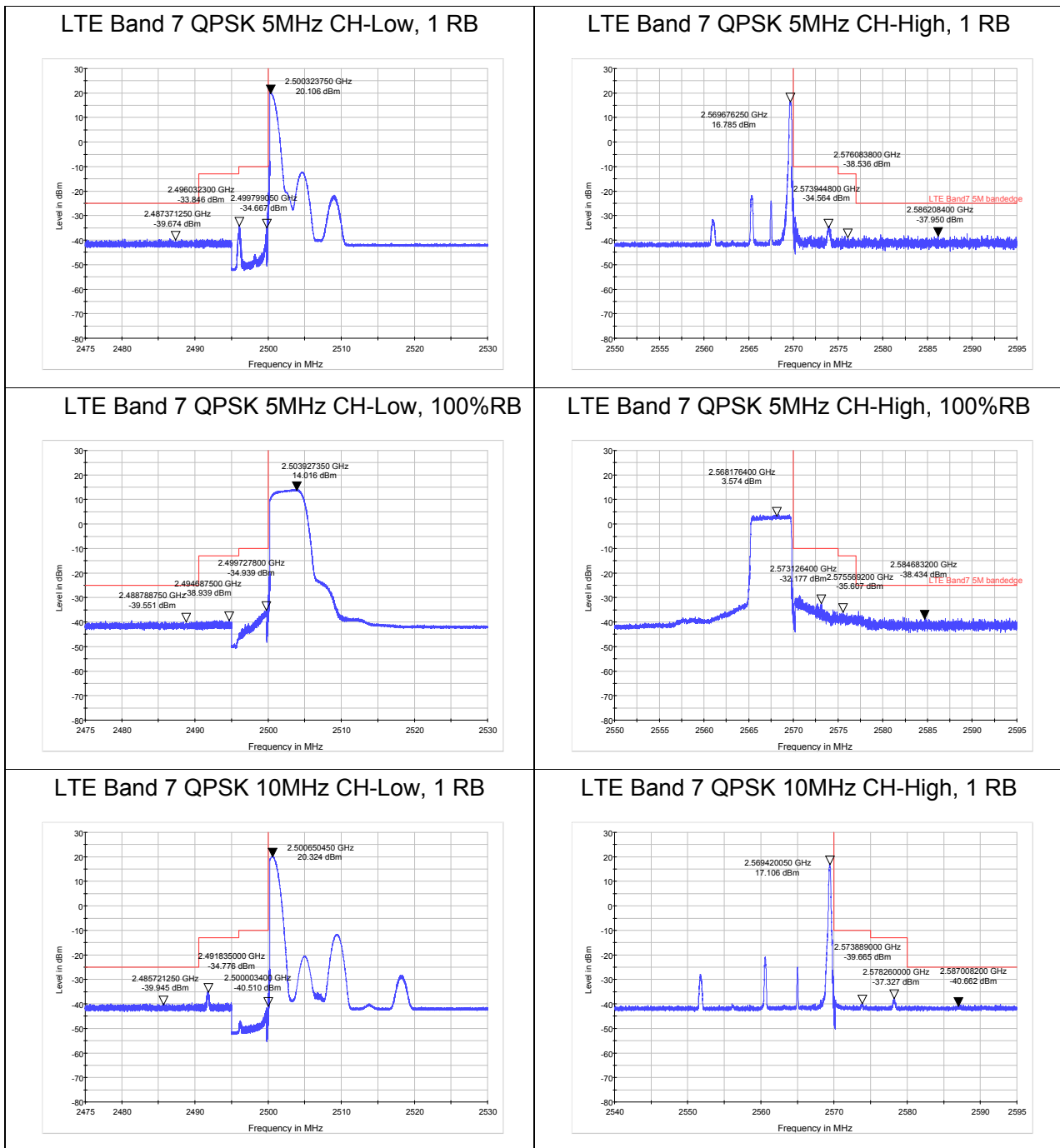



LTE Band 7 QPSK 10MHz CH-Low, 100%RB

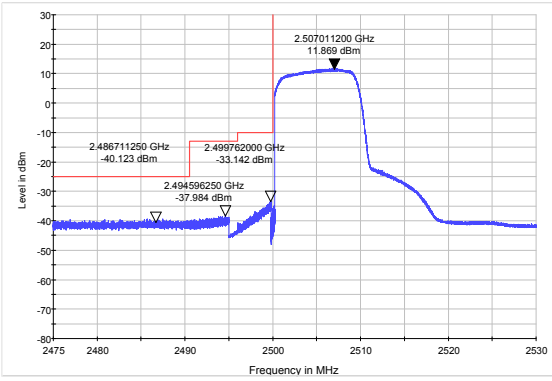

LTE Band 7 QPSK 10MHz CH-High, 100%RB

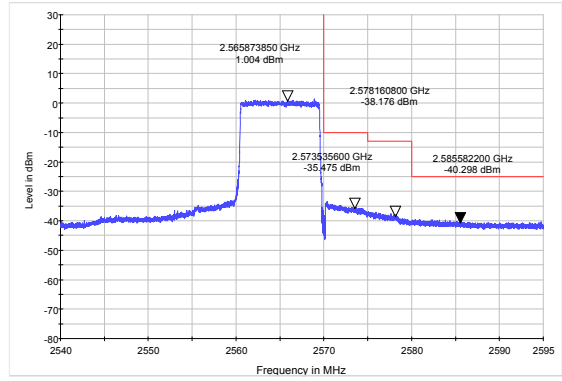

LTE Band 7 QPSK 15MHz CH-Low, 1 RB

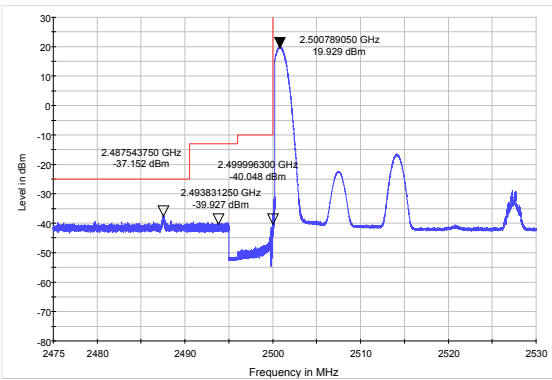

LTE Band 7 QPSK 15MHz CH-High, 1 RB

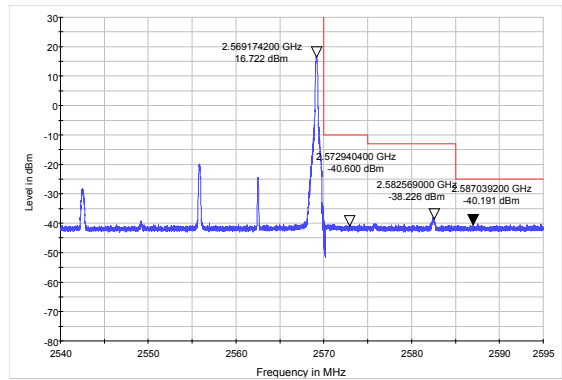

LTE Band 7 QPSK 15MHz CH-Low, 100%RB

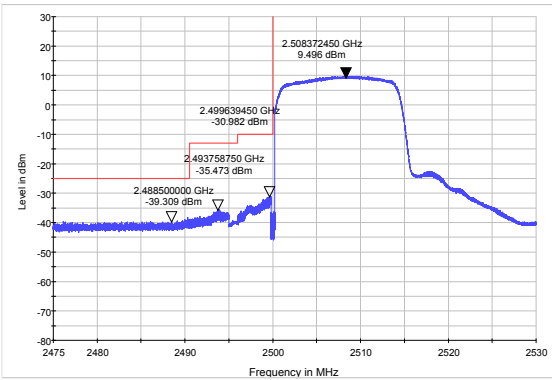

LTE Band 7 QPSK 15MHz CH-High, 100%RB

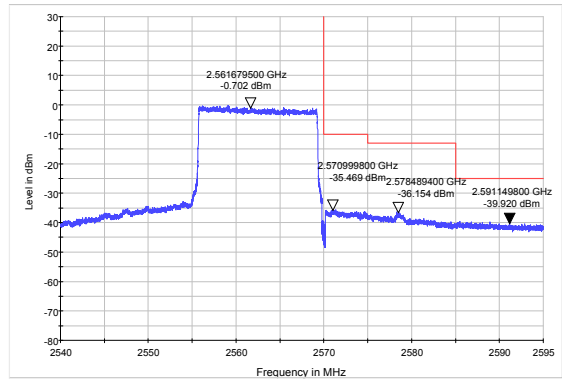

LTE Band 7 QPSK 20MHz CH-Low, 1 RB

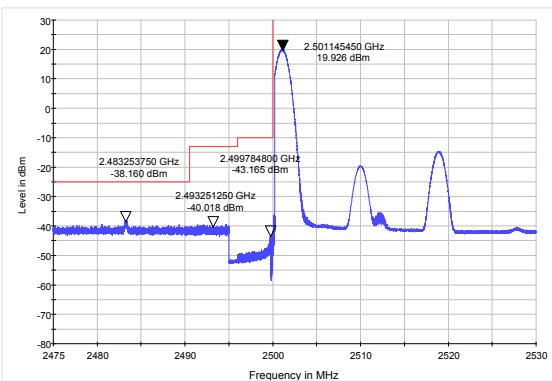

LTE Band 7 QPSK 20MHz CH-High, 1 RB

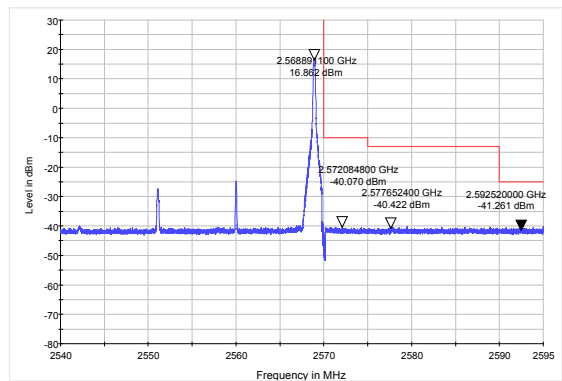



LTE Band 7 QPSK 20MHz CH-Low, 100%RB

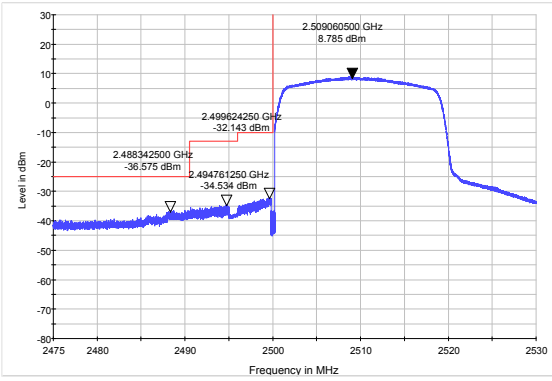

LTE Band 7 QPSK 20MHz CH-High, 100%RB

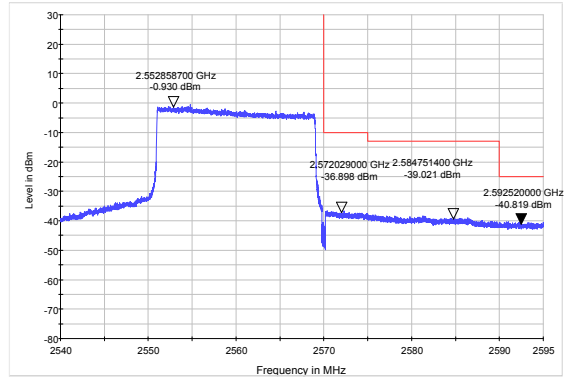

LTE Band 7 16QAM 5MHz CH-Low, 1 RB

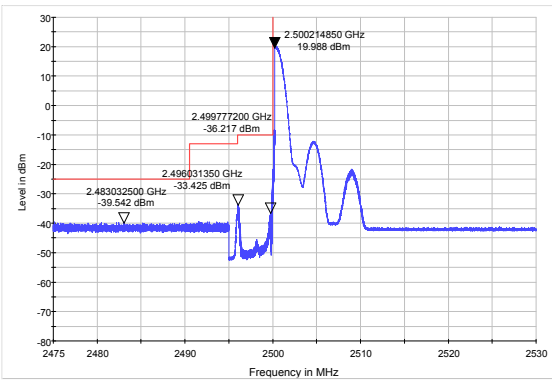

LTE Band 7 16QAM 5MHz CH-High, 1 RB

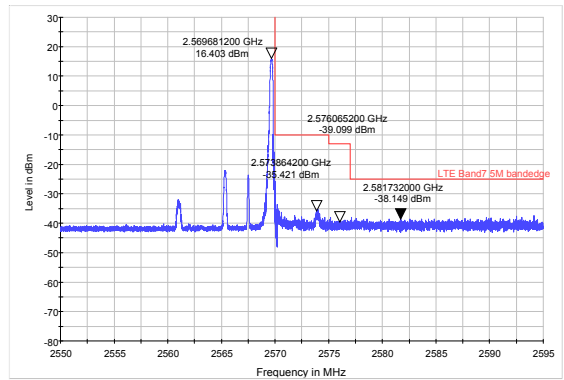

LTE Band 7 16QAM 5MHz CH-Low, 100%RB

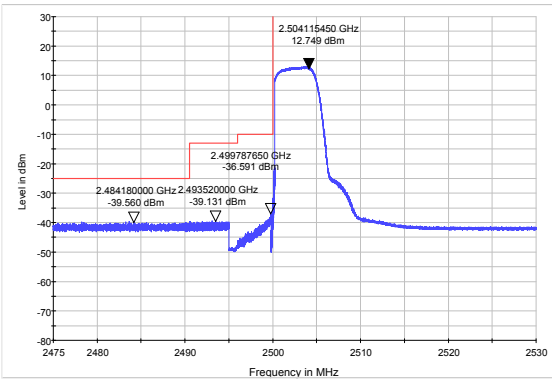

LTE Band 7 16QAM 5MHz CH-High, 100%RB

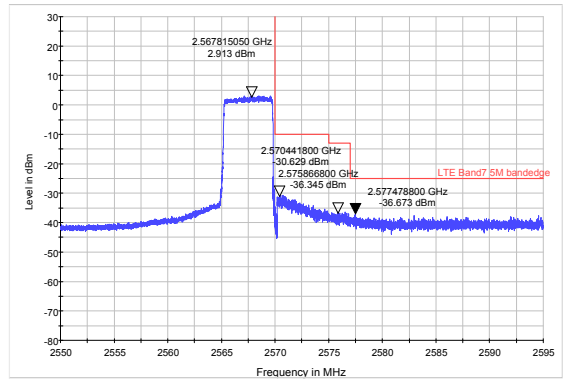

LTE Band 7 16QAM 10MHz CH-Low, 1 RB

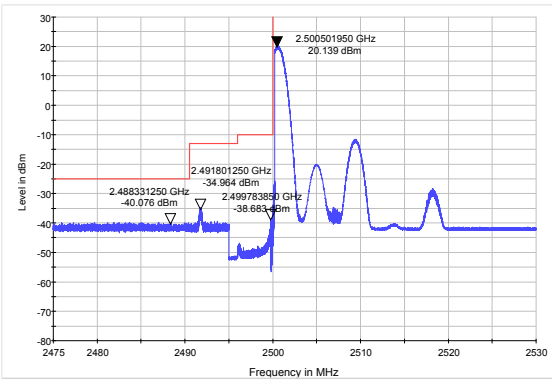

LTE Band 7 16QAM 10MHz CH-High, 1 RB

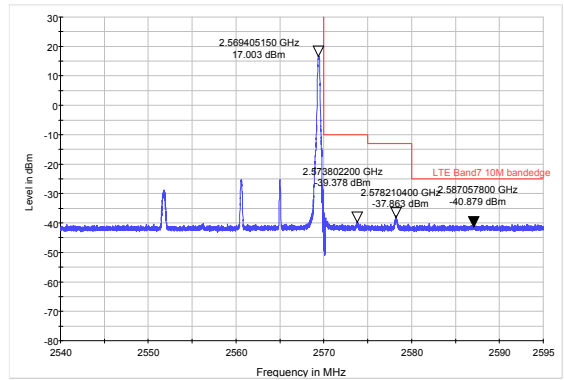



LTE Band 7 16QAM 10MHz CH-Low, 100%RB

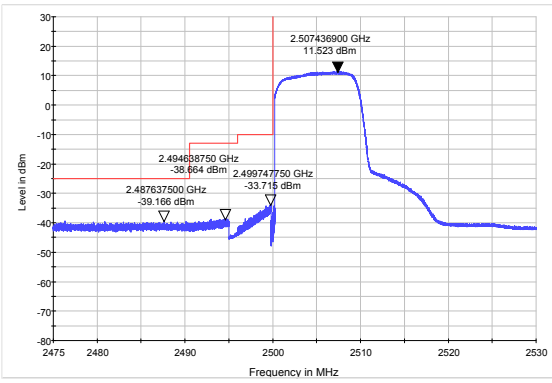

LTE Band 7 16QAM 10MHz CH-High, 100%RB

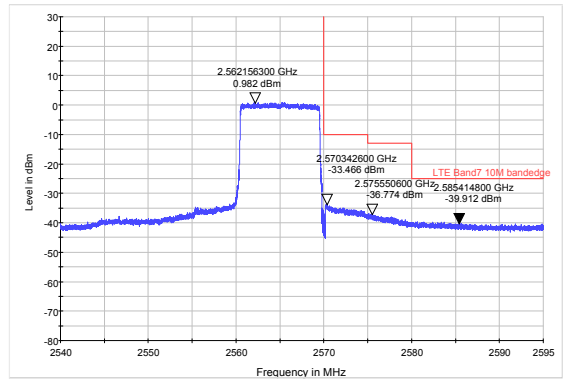

LTE Band 7 16QAM 15MHz CH-Low, 1 RB

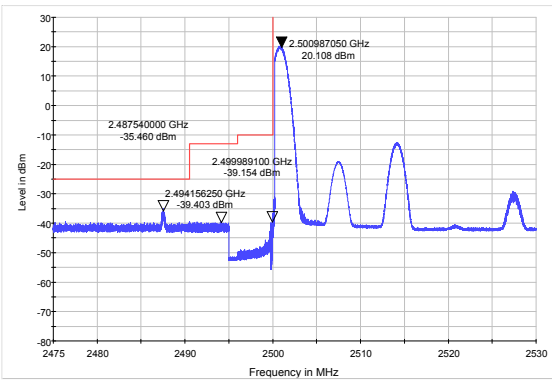

LTE Band 7 16QAM 15MHz CH-High, 1 RB

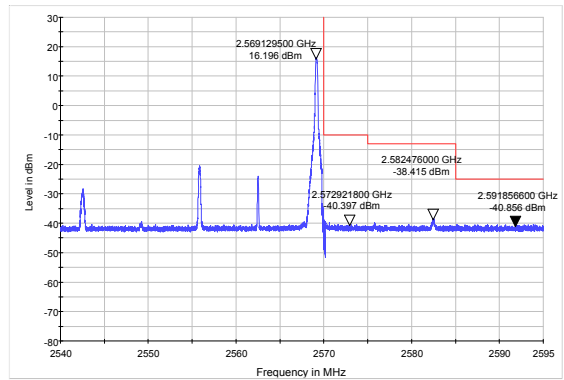

LTE Band 7 16QAM 15MHz CH-Low, 100%RB

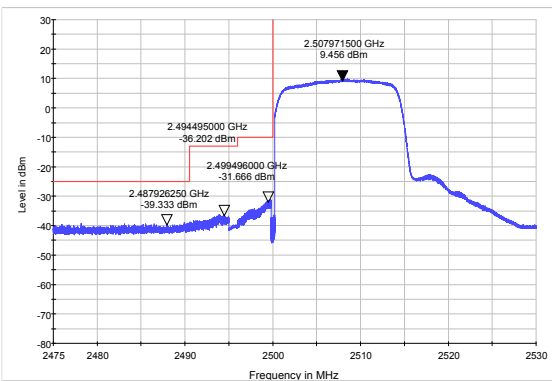

LTE Band 7 16QAM 15MHz CH-High, 100%RB

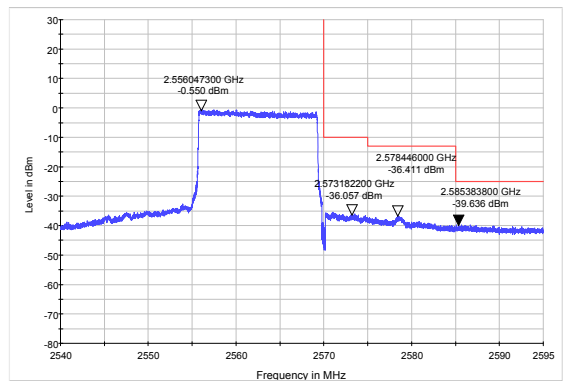

LTE Band 7 16QAM 20MHz CH-Low, 1 RB

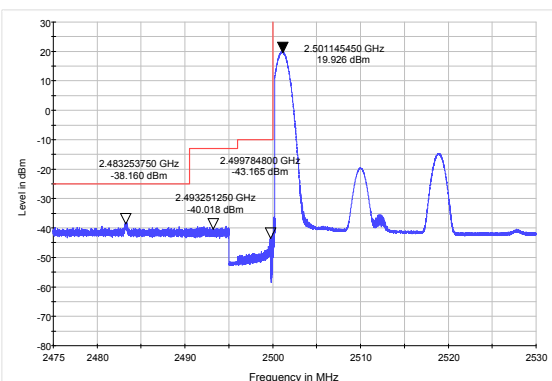

LTE Band 7 16QAM 20MHz CH-High, 1 RB

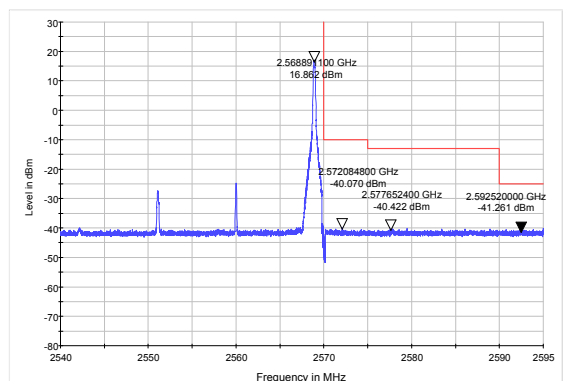



LTE Band 7 16QAM 20MHz CH-Low, 100%RB

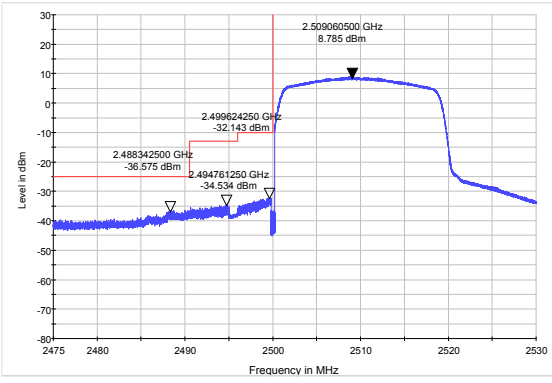

LTE Band 7 16QAM 20MHz CH-High, 100%RB

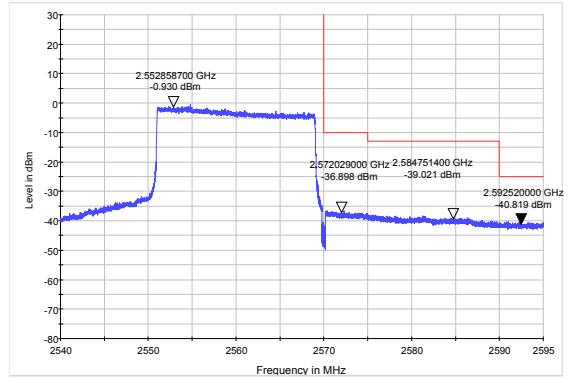



LTE Band 41 QPSK 5MHz CH-Low, 1 RB

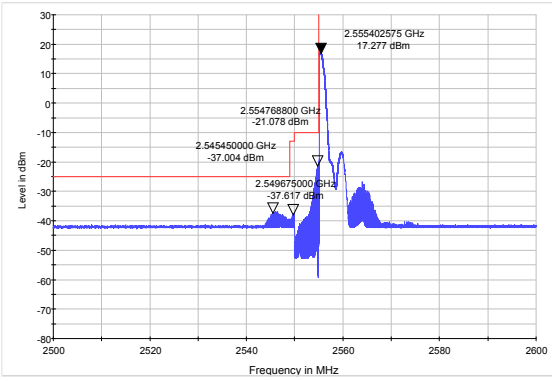

LTE Band 41 QPSK 5MHz CH-High, 1 RB

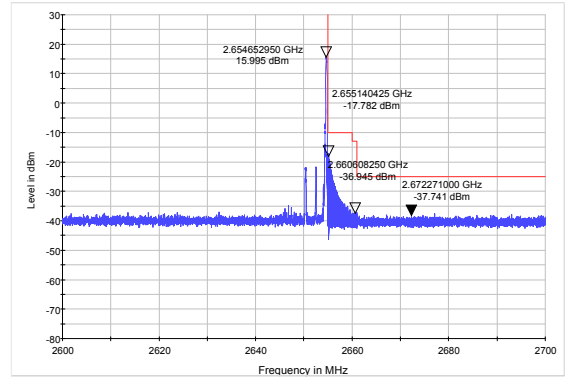

LTE Band 41 QPSK 5MHz CH-Low, 100%RB

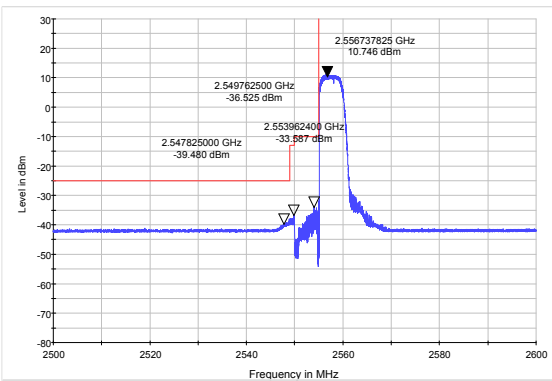

LTE Band 41 QPSK 5MHz CH-High, 100%RB

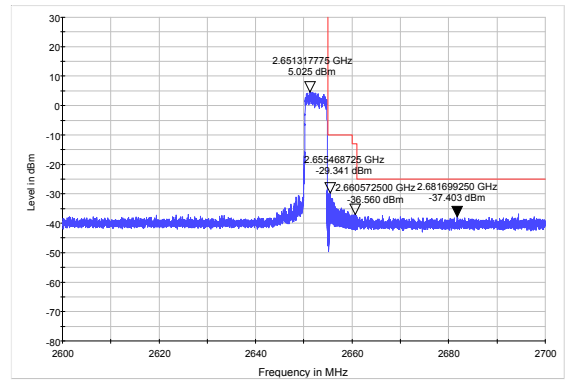

LTE Band 41 QPSK 10MHz CH-Low, 1 RB

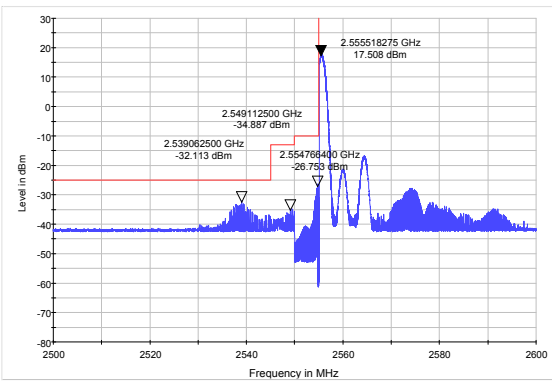

LTE Band 41 QPSK 10MHz CH-High, 1 RB

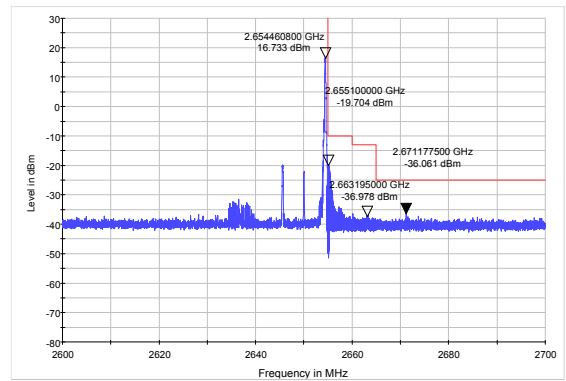

LTE Band 41 QPSK 10MHz CH-Low, 100%RB

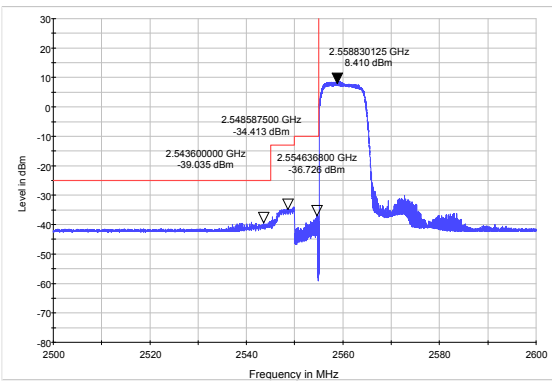

LTE Band 41 QPSK 10MHz CH-High, 100%RB

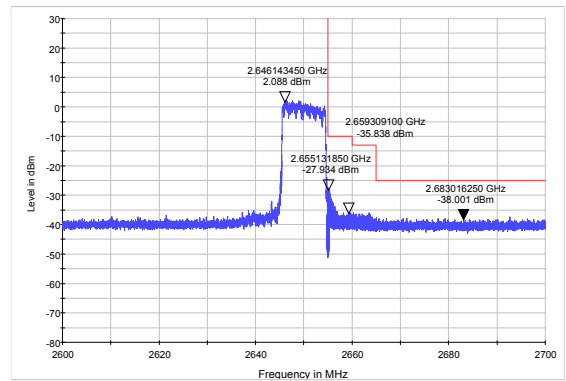



LTE Band 41 QPSK 15MHz CH-Low, 1 RB

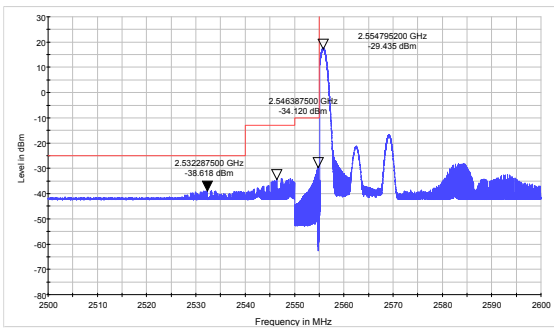

LTE Band 41 QPSK 15MHz CH-High, 1 RB

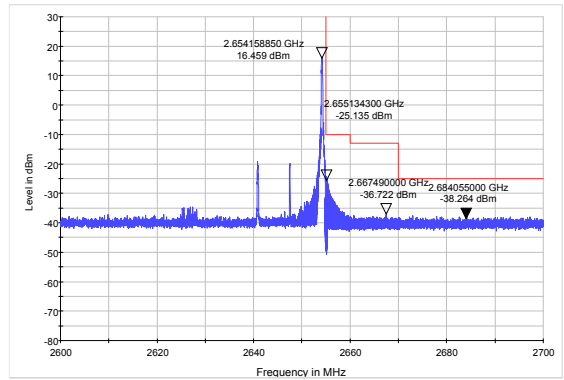

LTE Band 41 QPSK 15MHz CH-Low, 100%RB

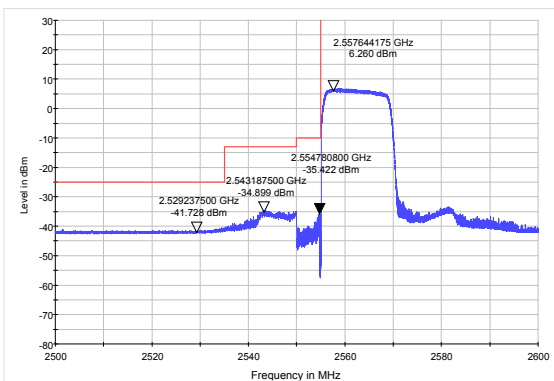

LTE Band 41 QPSK 15MHz CH-High, 100%RB

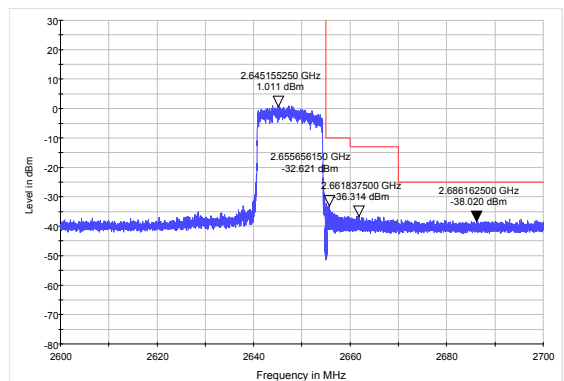

LTE Band 41 QPSK 20MHz CH-Low, 1 RB

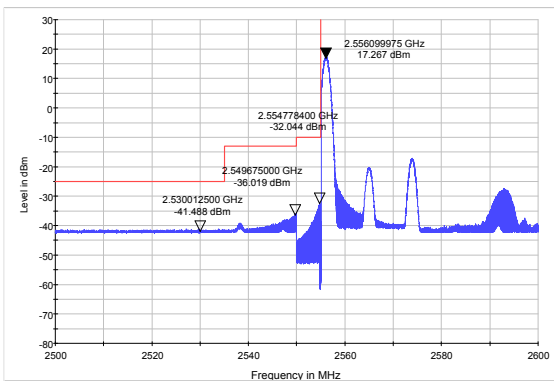

LTE Band 41 QPSK 20MHz CH-High, 1 RB

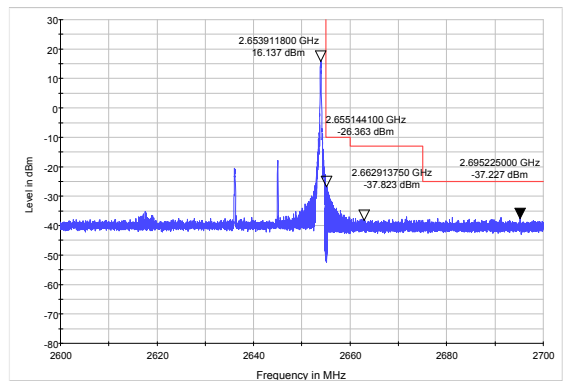

LTE Band 41 QPSK 20MHz CH-Low, 100%RB

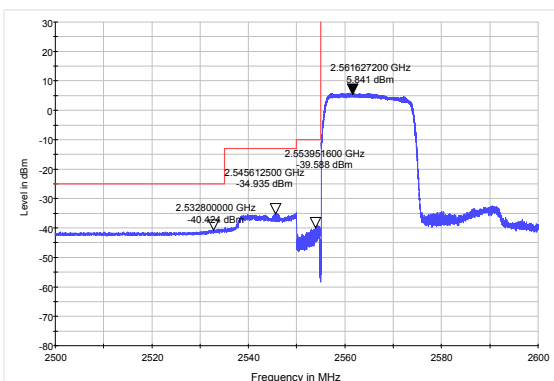

LTE Band 41 QPSK 20MHz CH-High, 100%RB

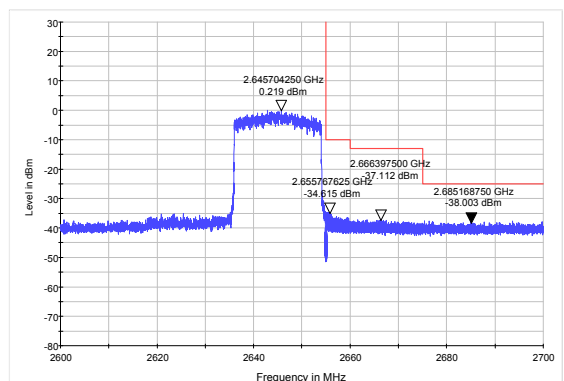



LTE Band 41 16QAM 5MHz CH-Low, 1 RB

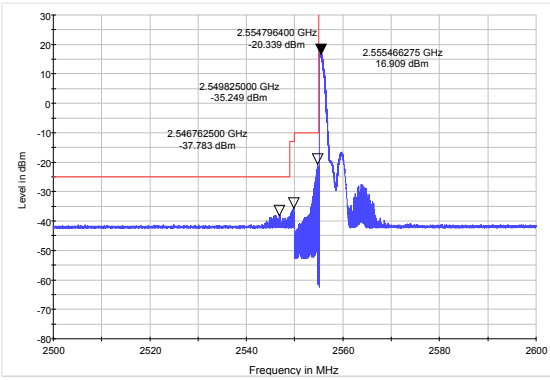

LTE Band 41 16QAM 5MHz CH-High, 1 RB

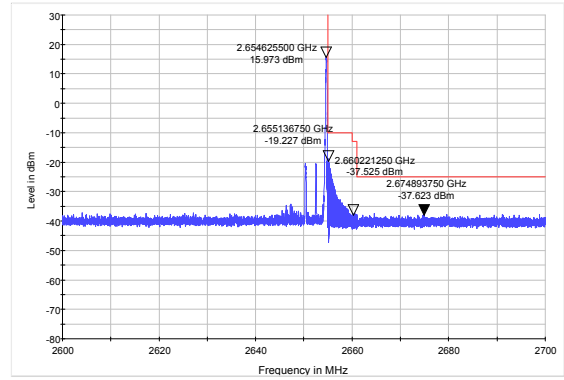

LTE Band 41 16QAM 5MHz CH-Low, 100%RB

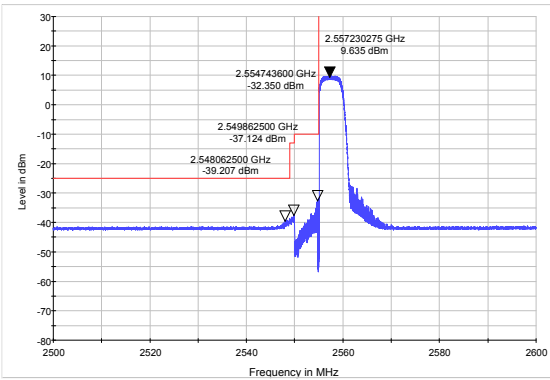

LTE Band 41 16QAM 5MHz CH-High, 100%RB

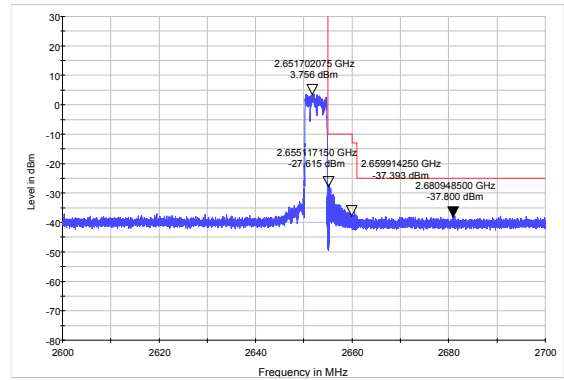

LTE Band 41 16QAM 10MHz CH-Low, 1 RB

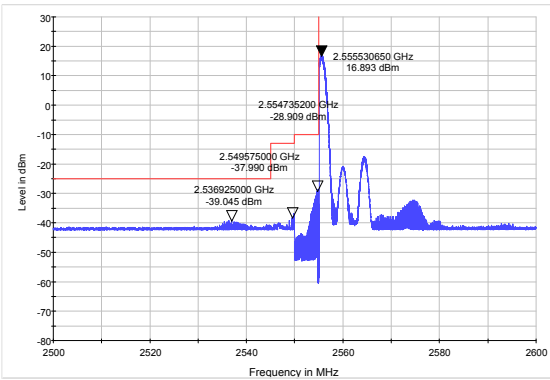

LTE Band 41 16QAM 10MHz CH-High, 1 RB

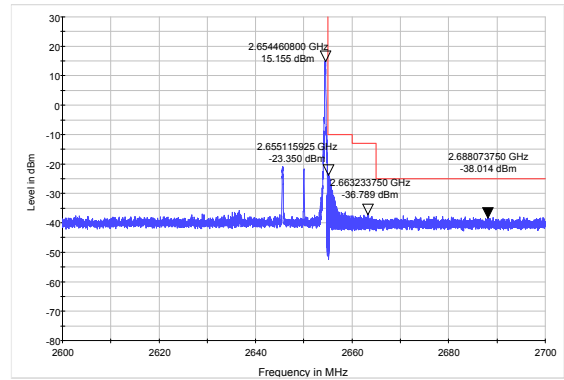





LTE Band 41 16QAM 10MHz CH-Low, 100%RB

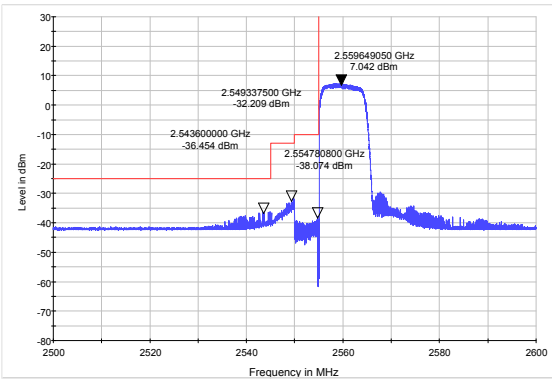

LTE Band 41 16QAM 10MHz CH-High, 100%RB

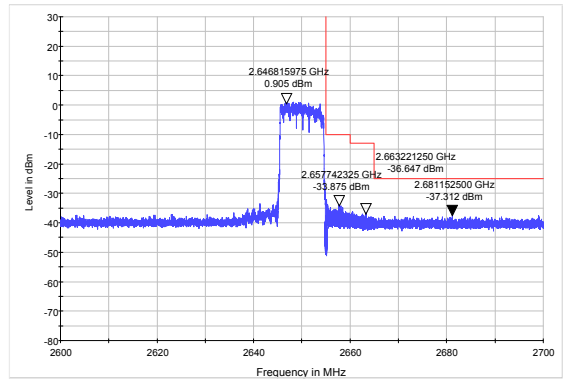

LTE Band 41 16QAM 15MHz CH-Low, 1 RB

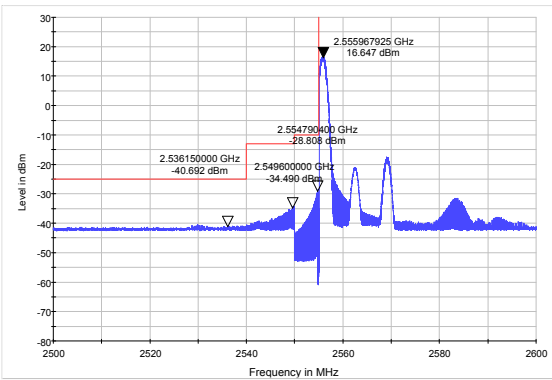

LTE Band 41 16QAM 15MHz CH-High, 1 RB

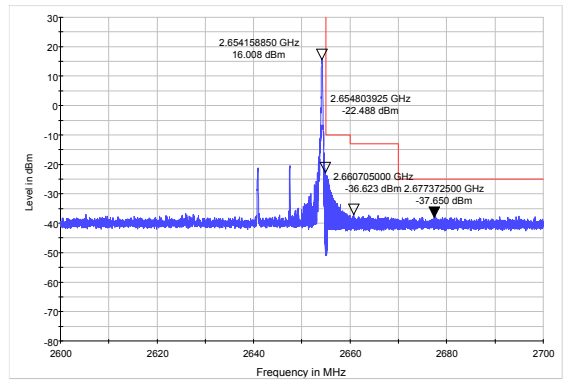

LTE Band 41 16QAM 15MHz CH-Low, 100%RB

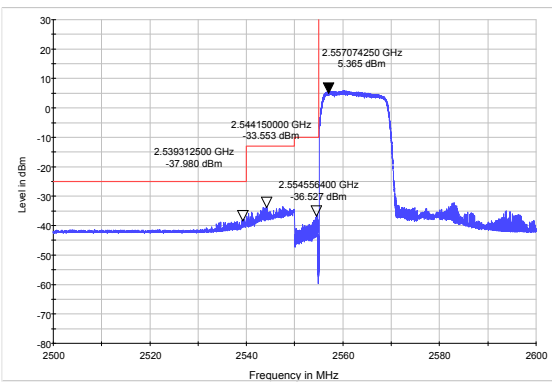

LTE Band 41 16QAM 15MHz CH-High, 100%RB

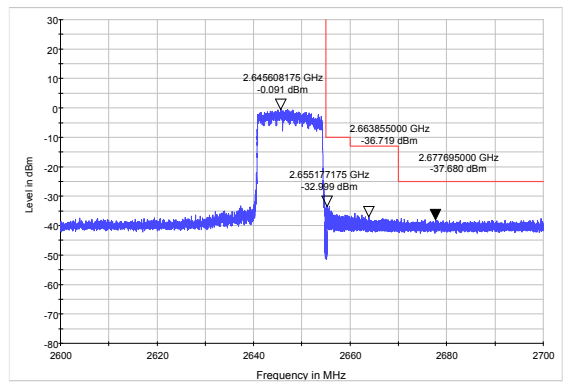

LTE Band 41 16QAM 20MHz CH-Low, RB 1

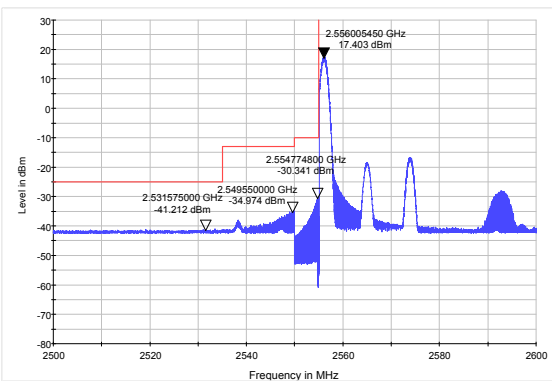

LTE Band 41 16QAM 20MHz CH-High, RB 1

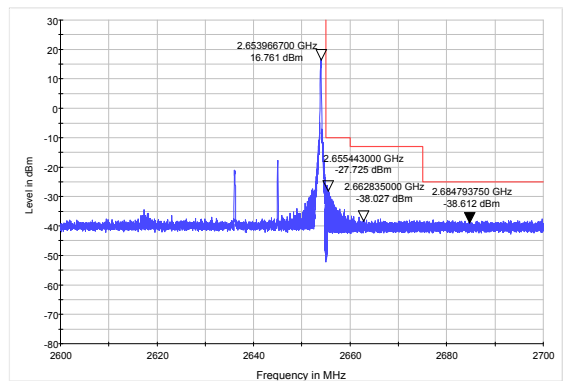



LTE Band 41 16QAM 20MHz CH-Low, 100%RB

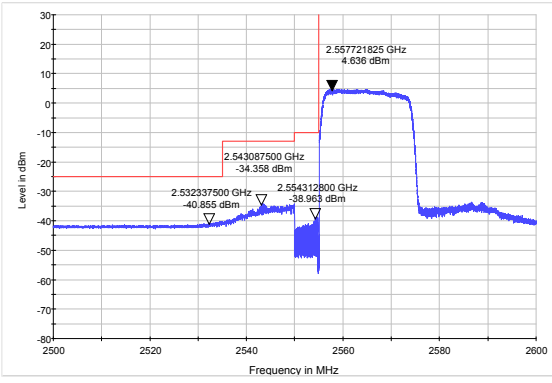

LTE Band 41 16QAM 20MHz CH-High, 100%RB

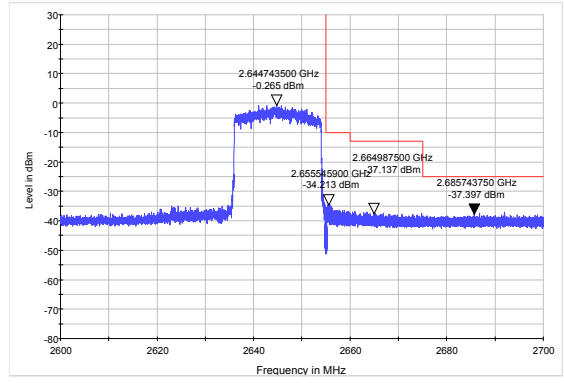

### 4.5 Peak-to-Average Power Ratio (PAPR)

#### Ambient condition

Temperature	Relative humidity	Pressure
23°C ~25°C	45%~50%	101.5kPa

#### Methods of Measurement

Measure the total peak power and record as PPk. And measure the total average power and record as PAvg. Both the peak and average power levels must be expressed in the same logarithmic units (e.g., dBm). Determine the PAPR from:

$$PAPR (dB) = PPk (dBm) - PAvg (dBm).$$

#### Test Setup

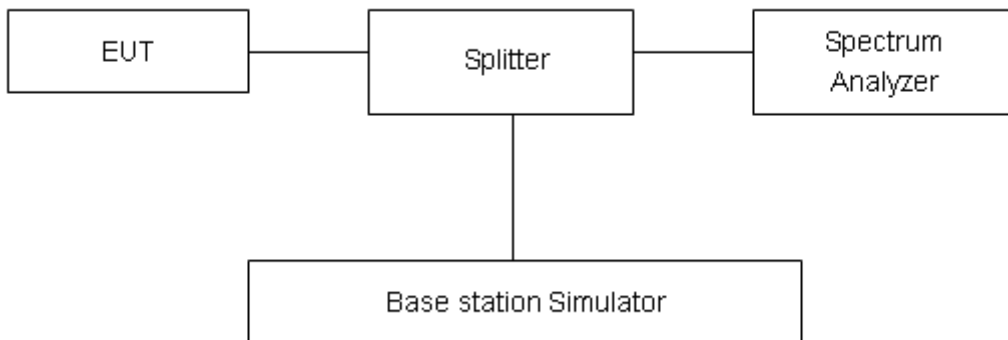

#### Limits

Rule Part 27.50(d)(5) Equipment employed must be authorized in accordance with the provisions of 24.51. Power measurements for transmissions by stations authorized under this section may be made either in accordance with a Commission-approved average power technique or in compliance with paragraph (d)(6) of this section. In measuring transmissions in this band using an average power technique, the peak-to-average ratio (PAR) of the transmission may not exceed 13 dB.

#### Measurement Uncertainty

The assessed measurement uncertainty to ensure 95% confidence level for the normal distribution is with the coverage factor k = 2, U= 0.4 dB.

**Test Results**

LTE Band 7								
Modulation	Bandwidth (MHz)	Channel	Frequency (MHz)	Peak (dBm)	Avg (dBm)	PAPR (dB)	Limit (dB)	Conclusion
QPSK	5	20775	2502.5	26.11	21.18	4.93	≤13	PASS
		21100	2535	26.92	21.76	5.16	≤13	PASS
		21425	2567.5	26.92	21.56	5.36	≤13	PASS
	10	20800	2505	26.06	21.26	4.80	≤13	PASS
		21100	2535	26.92	21.78	5.14	≤13	PASS
		21400	2565	26.91	21.60	5.31	≤13	PASS
	15	20825	2507.5	26.16	21.24	4.92	≤13	PASS
		21100	2535	27.05	21.74	5.31	≤13	PASS
		21375	2562.5	27.00	21.55	5.45	≤13	PASS
	20	20850	2510	26.09	21.21	4.88	≤13	PASS
		21100	2535	26.79	21.69	5.10	≤13	PASS
		21350	2560	26.78	21.51	5.27	≤13	PASS
16QAM	5	20775	2502.5	26.30	20.59	5.71	≤13	PASS
		21100	2535	26.65	20.69	5.96	≤13	PASS
		21425	2567.5	26.72	20.51	6.21	≤13	PASS
	10	20800	2505	25.84	20.62	5.22	≤13	PASS
		21100	2535	26.70	20.74	5.96	≤13	PASS
		21400	2565	26.27	20.55	5.72	≤13	PASS
	15	20825	2507.5	25.84	20.59	5.25	≤13	PASS
		21100	2535	26.74	20.69	6.05	≤13	PASS
		21375	2562.5	26.40	20.51	5.89	≤13	PASS
	20	20850	2510	25.88	20.57	5.31	≤13	PASS
		21100	2535	26.58	20.65	5.93	≤13	PASS
		21350	2560	26.26	20.48	5.78	≤13	PASS

LTE Band 41								
Modulation	Bandwidth ((MHz))	Channel	Frequency (MHz)	Peak (dBm)	Avg (dBm)	PAPR (dB)	Limit (dB)	Conclusion
QPSK	5	40265	2557.5	28.81	22.08	6.73	≤13	PASS
		40740	2605	29.15	22.24	6.91	≤13	PASS
		41215	2652.5	28.48	22.28	6.20	≤13	PASS
	10	40290	2560	28.66	22.16	6.50	≤13	PASS
		40740	2605	28.84	22.26	6.58	≤13	PASS
		41190	2650	28.66	22.32	6.34	≤13	PASS
	15	40315	2562.5	29.10	22.14	6.96	≤13	PASS
		40740	2605	29.45	22.22	7.23	≤13	PASS
		41165	2647.5	28.38	22.27	6.11	≤13	PASS
	20	40340	2565	29.06	22.11	6.95	≤13	PASS
		40740	2605	29.10	22.17	6.93	≤13	PASS
		41140	2645	28.37	22.23	6.14	≤13	PASS
16QAM	5	40265	2557.5	29.02	21.18	7.84	≤13	PASS
		40740	2605	29.01	21.29	7.72	≤13	PASS
		41215	2652.5	28.42	21.31	7.11	≤13	PASS
	10	40290	2560	29.08	21.21	7.87	≤13	PASS
		40740	2605	28.96	21.34	7.62	≤13	PASS
		41190	2650	28.43	21.35	7.08	≤13	PASS
	15	40315	2562.5	28.78	21.18	7.60	≤13	PASS
		40740	2605	28.89	21.29	7.60	≤13	PASS
		41165	2647.5	28.03	21.31	6.72	≤13	PASS
	20	40340	2565	28.71	21.16	7.55	≤13	PASS
		40740	2605	28.70	21.25	7.45	≤13	PASS
		41140	2645	28.18	21.28	6.90	≤13	PASS

## 4.6 Frequency Stability

### Ambient condition

Temperature	Relative humidity	Pressure
23°C ~25°C	45%~50%	101.5kPa

### Method of Measurement

#### 1. Frequency Stability (Temperature Variation)

The temperature inside the climate chamber is varied from -40°C to +85°C in 10°C step size.

(1)With all power removed, the temperature was decreased to -10°C and permitted to stabilize for three hours.

(2)Measure the carrier frequency with the test equipment in a “call mode”. These measurements should be made within 1 minute of powering up the mobile station, to prevent significant self warming.

(3) Repeat the above measurements at 10°C increments from -40°C to +85°C Allow at least 1.5 hours at each temperature, un-powered, before making measurements.

#### 2. Frequency Stability (Voltage Variation)

The frequency stability shall be measured with variation of primary supply voltage as follows:

(1) Vary primary supply voltage from 85 to 115 percent of the nominal value for other than hand carried battery equipment.

(2) For hand carried, battery powered equipment, reduce primary supply voltage to the battery-operating end point which shall be specified by the manufacturer.

This transceiver is specified to operate with an input voltage of between 3.3 V and 4.3 V, with a nominal voltage of 3.8V.

### Test setup

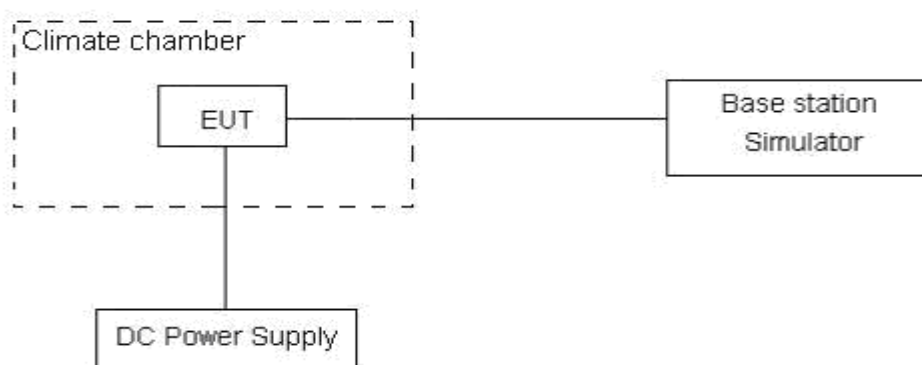

### Limits

No specific frequency stability requirements in part 27.54

### Measurement Uncertainty

The assessed measurement uncertainty to ensure 99.75% confidence level for the normal distribution is with the coverage factor  $k = 3, U=0.01\text{ppm}$ .

**Test Result**

Bandwidth	Test status	LTE Band 7 Channel 21100 Test Results (ppm)	
		QPSK	16QAM
5MHz	-40°C/Normal Voltage	-0.00004	-0.00007
	-30°C/Normal Voltage	0.00089	-0.00010
	-20°C/Normal Voltage	-0.00121	-0.00172
	-10°C/Normal Voltage	0.00141	-0.00172
	0°C/Normal Voltage	0.00023	-0.00031
	10°C/Normal Voltage	0.00093	0.00165
	20°C/Normal Voltage	0.00138	-0.00006
	30°C/Normal Voltage	-0.00063	-0.00112
	40°C/Normal Voltage	0.00114	0.00026
	50°C/Normal Voltage	0.00120	0.00277
	60°C/Normal Voltage	0.00307	0.00201
	70°C/Normal Voltage	-0.00040	0.00127
	80°C/Normal Voltage	-0.00078	-0.00033
	85°C/Normal Voltage	-0.00308	0.00052
	20°C/Minimum Voltage	-0.00047	0.00072
	20°C/Maximum Voltage	-0.00329	0.00110
10MHz	-40°C/Normal Voltage	-0.00217	0.00084
	-30°C/Normal Voltage	-0.00313	0.00079
	-20°C/Normal Voltage	-0.00066	0.00047
	-10°C/Normal Voltage	-0.00238	-0.00123
	0°C/Normal Voltage	-0.00038	-0.00249
	10°C/Normal Voltage	-0.00055	-0.00032
	20°C/Normal Voltage	-0.00034	-0.00114
	30°C/Normal Voltage	-0.00262	0.00050
	40°C/Normal Voltage	-0.00085	-0.00138
	50°C/Normal Voltage	0.00002	0.00071
	60°C/Normal Voltage	0.00096	0.00098
	70°C/Normal Voltage	-0.00164	-0.00202
	80°C/Normal Voltage	-0.00014	0.00058
	85°C/Normal Voltage	0.00262	-0.00157
	20°C/Minimum Voltage	-0.00118	-0.00255
	20°C/Maximum Voltage	-0.00125	-0.00176
15MHz	-40°C/Normal Voltage	-0.00045	0.00045
	-30°C/Normal Voltage	-0.00132	-0.00032
	-20°C/Normal Voltage	-0.00072	0.00118



	-10°C/Normal Voltage	0.00163	-0.00139
	0°C/Normal Voltage	-0.00167	0.00099
	10°C/Normal Voltage	0.00002	-0.00135
	20°C/Normal Voltage	-0.00171	0.00080
	30°C/Normal Voltage	-0.00101	0.00004
	40°C/Normal Voltage	-0.00166	0.00357
	50°C/Normal Voltage	-0.00080	0.00286
	60°C/Normal Voltage	-0.00164	0.00215
	70°C/Normal Voltage	-0.00084	-0.00101
	80°C/Normal Voltage	-0.00076	0.00039
	85°C/Normal Voltage	-0.00196	0.00248
	20°C/Minimum Voltage	-0.00022	0.00279
	20°C/Maximum Voltage	-0.00304	0.00169
	20MHz	-40°C/Normal Voltage	0.00037
-30°C/Normal Voltage		0.00012	0.00202
-20°C/Normal Voltage		-0.00059	0.00363
-10°C/Normal Voltage		-0.00112	0.00181
0°C/Normal Voltage		-0.00133	0.00084
10°C/Normal Voltage		-0.00162	0.00030
20°C/Normal Voltage		-0.00134	0.00080
30°C/Normal Voltage		-0.00247	0.00280
40°C/Normal Voltage		-0.00157	-0.00092
50°C/Normal Voltage		-0.00389	0.00058
60°C/Normal Voltage		0.00002	-0.00241
70°C/Normal Voltage		-0.00209	0.00047
80°C/Normal Voltage		-0.00151	0.00004
85°C/Normal Voltage		-0.00109	-0.00157
20°C/Minimum Voltage	-0.00282	-0.00166	
20°C/Maximum Voltage	-0.00127	-0.00162	



Bandwidth	Test status	LTE Band 41 Channel 40740 Test Results (ppm)	
		QPSK	16QAM
5MHz	-40°C/Normal Voltage	-0.00053	0.00021
	-30°C/Normal Voltage	0.00005	-0.00118
	-20°C/Normal Voltage	0.00055	0.00121
	-10°C/Normal Voltage	-0.00080	-0.00146
	0°C/Normal Voltage	-0.00002	-0.00222
	10°C/Normal Voltage	-0.00021	-0.00200
	20°C/Normal Voltage	-0.00063	-0.00012
	30°C/Normal Voltage	-0.00075	0.00000
	40°C/Normal Voltage	-0.00024	-0.00165
	50°C/Normal Voltage	0.00015	-0.00093
	60°C/Normal Voltage	-0.00003	-0.00039
	70°C/Normal Voltage	-0.00064	0.00019
	80°C/Normal Voltage	0.00003	-0.00148
	85°C/Normal Voltage	-0.00100	-0.00045
	20°C/Minimum Voltage	-0.00043	0.00051
	20°C/Maximum Voltage	-0.00052	-0.00276
10MHz	-40°C/Normal Voltage	-0.00033	0.00065
	-30°C/Normal Voltage	-0.00127	-0.00090
	-20°C/Normal Voltage	-0.00361	0.00042
	-10°C/Normal Voltage	0.00198	-0.00070
	0°C/Normal Voltage	0.00126	-0.00220
	10°C/Normal Voltage	0.00051	0.00076
	20°C/Normal Voltage	-0.00127	-0.00180
	30°C/Normal Voltage	-0.00144	0.00008
	40°C/Normal Voltage	0.00072	-0.00132
	50°C/Normal Voltage	-0.00190	-0.00162
	60°C/Normal Voltage	-0.00127	-0.00114
	70°C/Normal Voltage	0.00034	-0.00227
	80°C/Normal Voltage	0.00130	-0.00146
	85°C/Normal Voltage	-0.00222	-0.00159
	20°C/Minimum Voltage	-0.00114	-0.00051
	20°C/Maximum Voltage	-0.00274	-0.00193
15MHz	-40°C/Normal Voltage	-0.00030	-0.00299
	-30°C/Normal Voltage	-0.00194	-0.00310
	-20°C/Normal Voltage	-0.00296	-0.00134
	-10°C/Normal Voltage	-0.00155	-0.00333



	0°C/Normal Voltage	-0.00192	-0.00281
	10°C/Normal Voltage	-0.00055	-0.00151
	20°C/Normal Voltage	-0.00231	-0.00076
	30°C/Normal Voltage	-0.00222	-0.00138
	40°C/Normal Voltage	-0.00125	-0.00118
	50°C/Normal Voltage	-0.00051	-0.00348
	60°C/Normal Voltage	0.00092	-0.00111
	70°C/Normal Voltage	-0.00239	-0.00203
	80°C/Normal Voltage	-0.00350	-0.00234
	85°C/Normal Voltage	-0.00104	-0.00084
	20°C/Minimum Voltage	-0.00330	-0.00184
	20°C/Maximum Voltage	-0.00169	-0.00247
	20MHz	-40°C/Normal Voltage	-0.00197
-30°C/Normal Voltage		-0.00129	-0.00079
-20°C/Normal Voltage		-0.00352	-0.00230
-10°C/Normal Voltage		-0.00063	0.00052
0°C/Normal Voltage		-0.00291	0.00163
10°C/Normal Voltage		-0.00038	-0.00086
20°C/Normal Voltage		-0.00081	0.00150
30°C/Normal Voltage		0.00052	0.00187
40°C/Normal Voltage		-0.00079	-0.00192
50°C/Normal Voltage		-0.00205	-0.00301
60°C/Normal Voltage		-0.00341	-0.00333
70°C/Normal Voltage		-0.00074	0.00094
80°C/Normal Voltage		-0.00095	-0.00059
85°C/Normal Voltage		-0.00148	-0.00264
20°C/Minimum Voltage		-0.00176	-0.00109
20°C/Maximum Voltage	-0.00272	-0.00303	

### 4.7 Spurious Emissions at Antenna Terminals

#### Ambient condition

Temperature	Relative humidity	Pressure
23°C ~25°C	45%~50%	101.5kPa

#### Method of Measurement

The EUT was connected to Spectrum Analyzer and Base Station Simulator via power Splitter. The measurement is carried out using a spectrum analyzer. The spectrum analyzer scans from 30MHz to the 10th harmonic of the carrier. The peak detector is used. Set RBW 1MHz and VBW 3MHz, Sweep is set to ATUO.

Of those disturbances below (limit – 20 dB), the mark is not required for the EUT.

#### Test setup

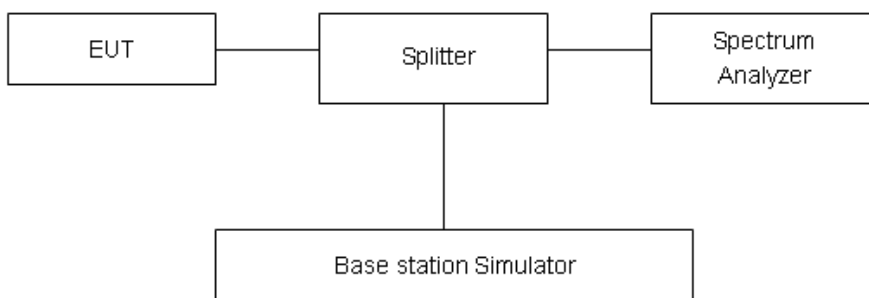

#### Limits

Rule Part 27.53(m)  $55 + 10 \log (P)$  dB on all frequencies more than X megahertz from the channel edge, where X is the greater of 6 megahertz or the actual emission bandwidth as defined in paragraph (m)(4) of this section.

LTE -7 Limit	-25 dBm
--------------	---------

#### Measurement Uncertainty

The assessed measurement uncertainty to ensure 99.75% confidence level for the normal distribution is with the coverage factor  $k = 1.96$ .

Frequency	Uncertainty
100kHz-2GHz	0.684 dB
2GHz-12.75GHz	1.407 dB

**Test Result: PASS**

LTE Band 7 5MHz CH-Low 30MHz~3GHz

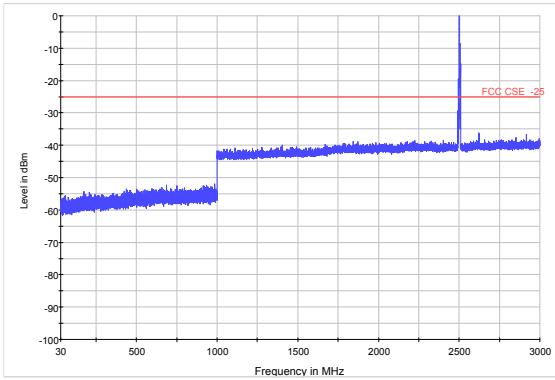

LTE Band 7 5MHz CH-Middle 30MHz~3GHz

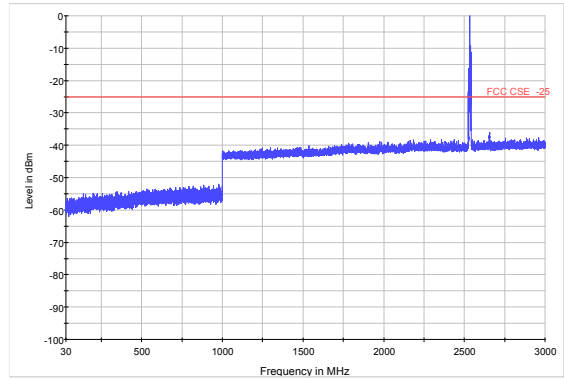

LTE Band 7 5MHz CH-Low 3GHz~18GHz

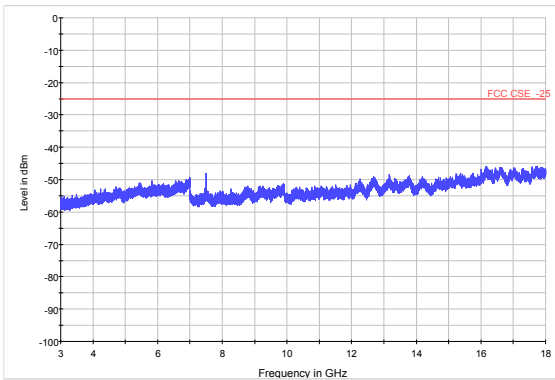

LTE Band 7 5MHz CH-Middle 3GHz~18GHz

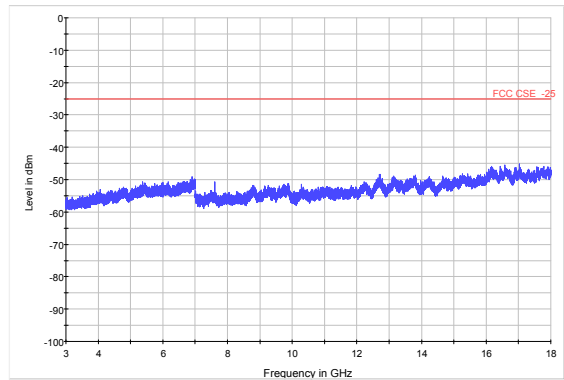

LTE Band 7 5MHz CH-Low 18GHz~26.5GHz

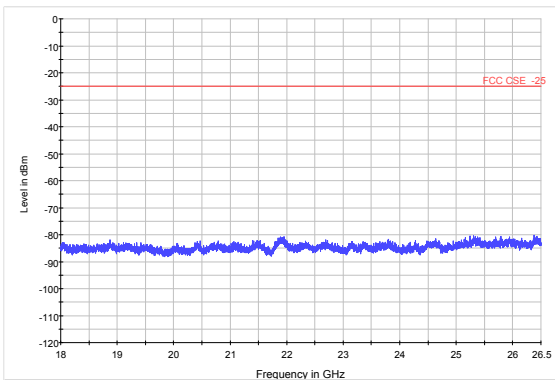

LTE Band 7 5MHz CH-Middle 18GHz~26.5GHz

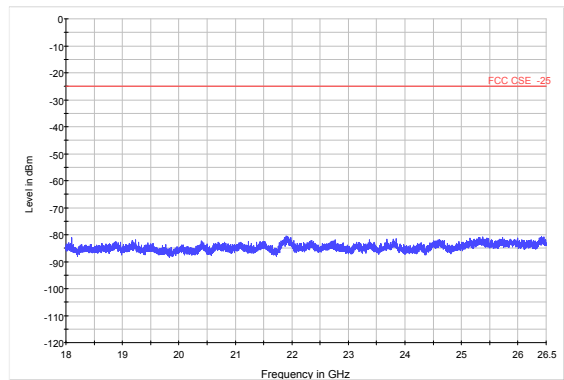



LTE Band 7 5MHz CH-High 30MHz~3GHz

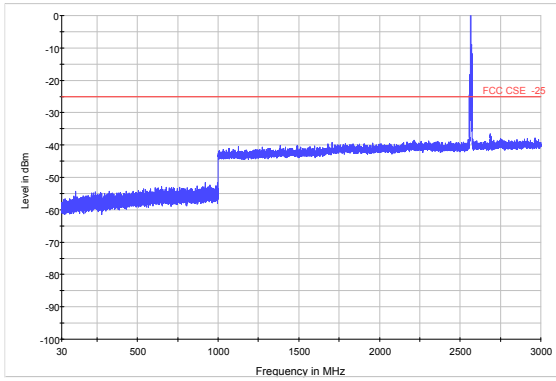

LTE Band 7 10MHz CH-Low 30MHz~3GHz

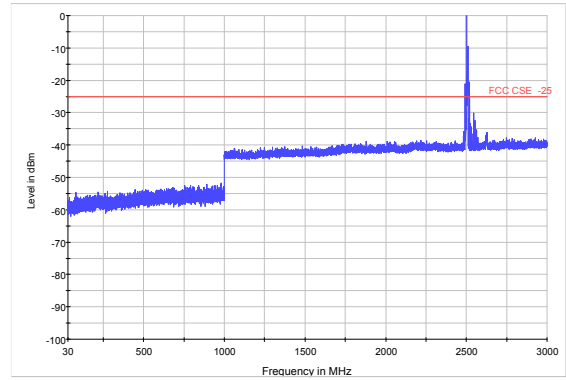

LTE Band 7 5MHz CH-High 3GHz~18GHz

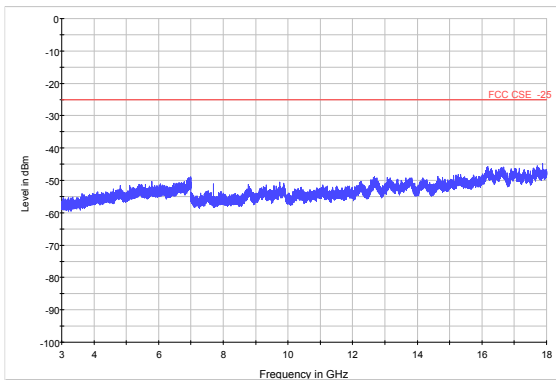

LTE Band 7 10MHz CH-Low 3GHz~18GHz

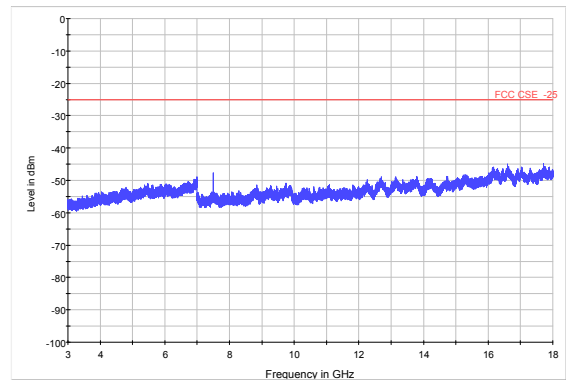

LTE Band 7 5MHz CH-High 18GHz~26.5GHz

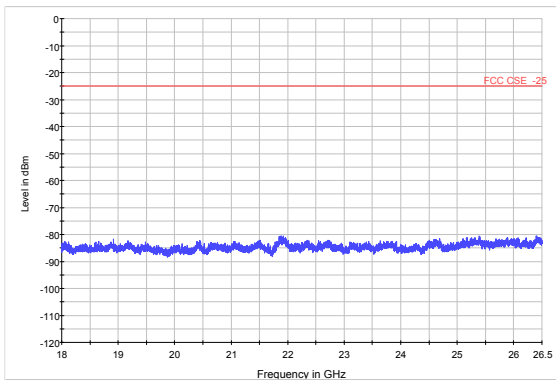

LTE Band 7 10MHz C CH-Low 18GHz~26.5GHz

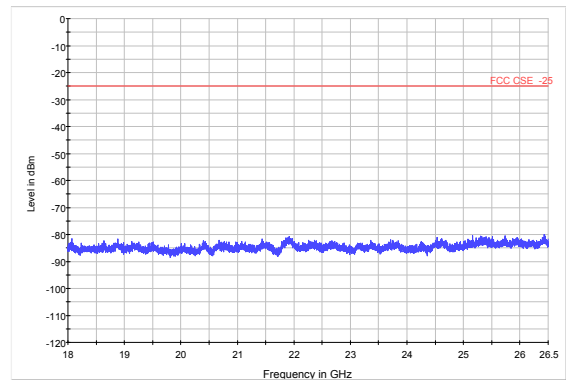



LTE Band 7 10MHz CH-Middle 30MHz~3GHz

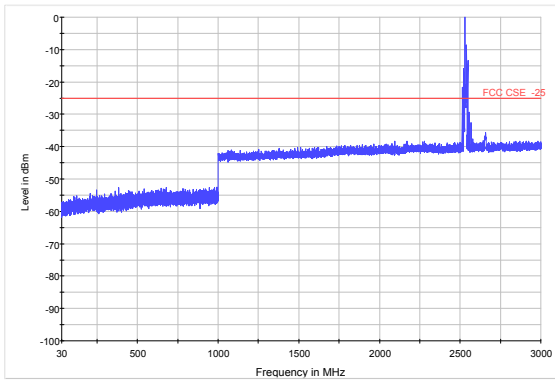

LTE Band 7 10MHz CH-High 30MHz~3GHz

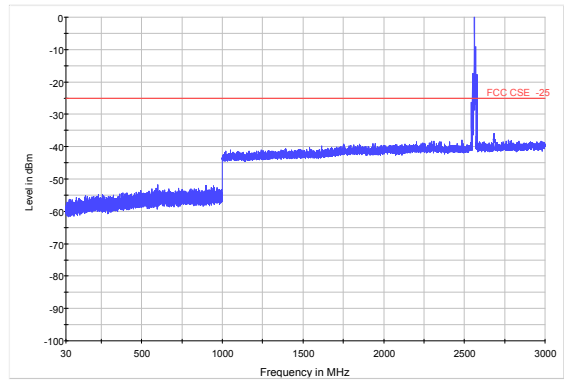

LTE Band 7 10MHz CH-Middle 3GHz~18GHz

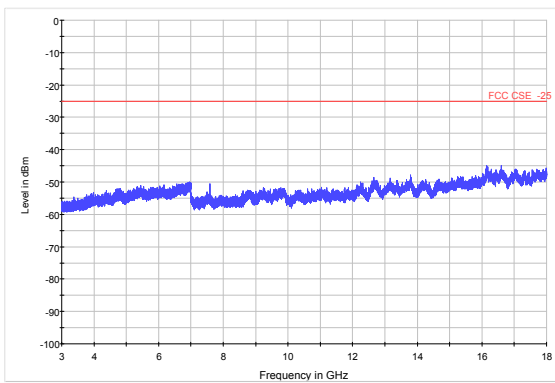

LTE Band 7 10MHz CH-High 3GHz~18GHz

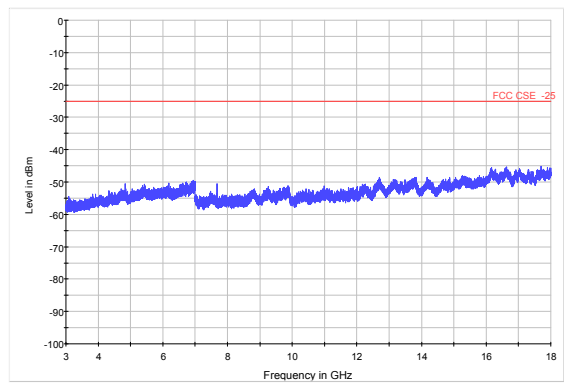

LTE Band 7 10MHz CH-Middle 18GHz~26.5GHz

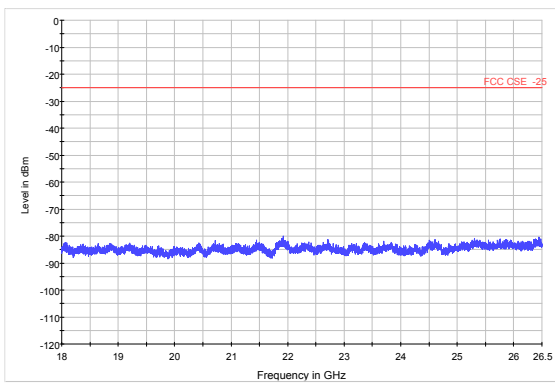

LTE Band 7 10MHz CH-High 18GHz~26.5GHz

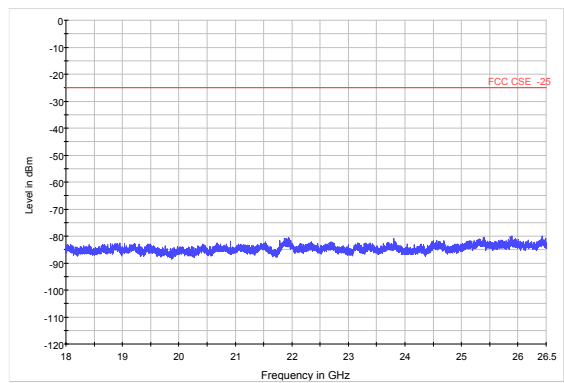



LTE Band 7 15MHz CH-Low 30MHz~3GHz

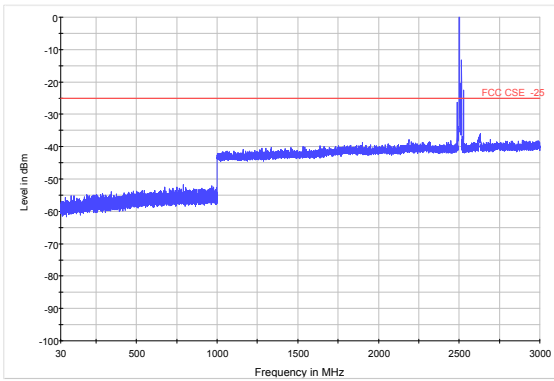

LTE Band 7 15MHz CH-Middle 30MHz~3GHz

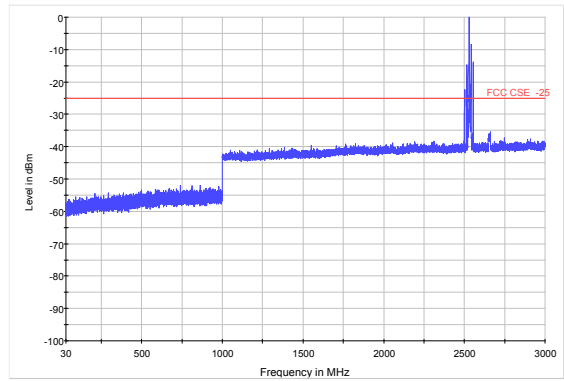

LTE Band 7 15MHz CH-Low 3GHz~18GHz

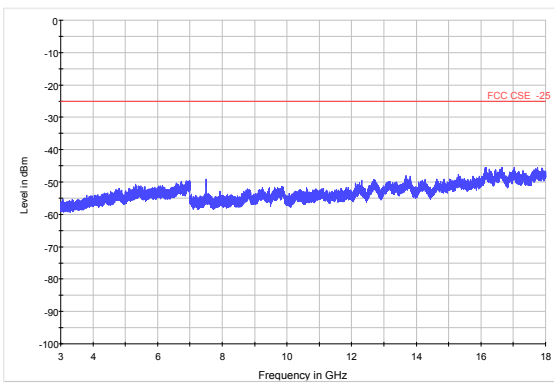

LTE Band 7 15MHz CH-Middle 3GHz~18GHz

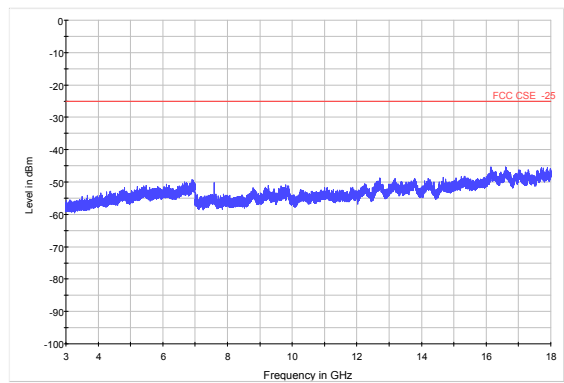

LTE Band 7 15MHz CH-Low 18GHz~26.5GHz

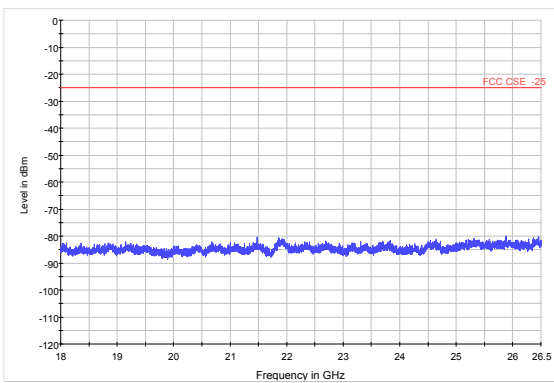

LTE Band 7 15MHz CH-Middle 18GHz~26.5GHz

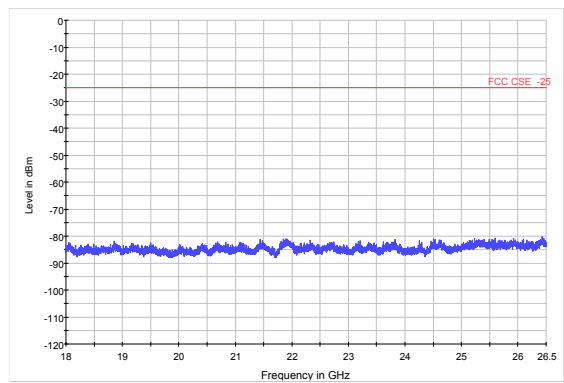

LTE Band 7 15MHz CH-High 30MHz~3GHz

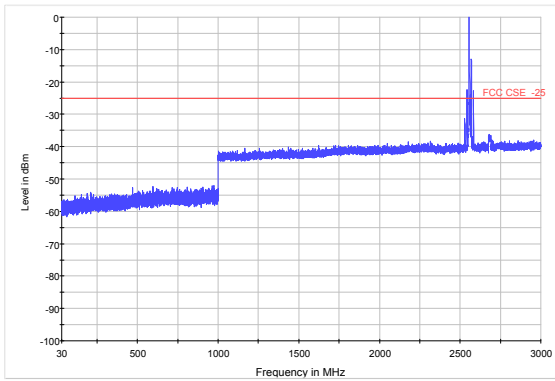

LTE Band 7 20MHz CH-Low 30MHz~3GHz

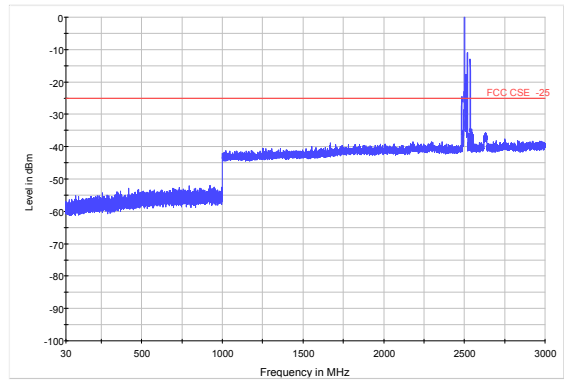

LTE Band 7 15MHz CH-High 3GHz~18GHz

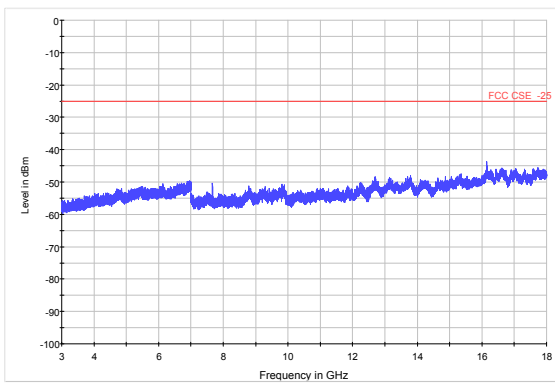

LTE Band 7 20MHz CH-Low 3GHz~18GHz

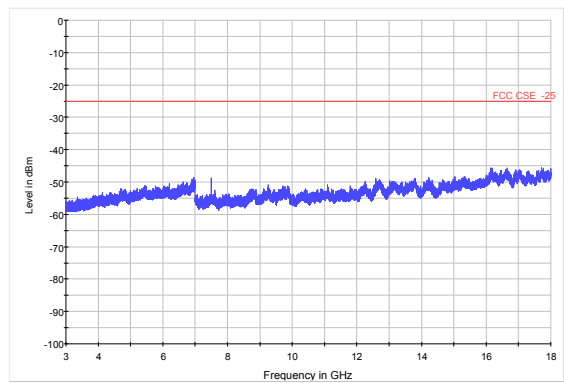

LTE Band 7 15MHz CH-High 18GHz~26.5GHz

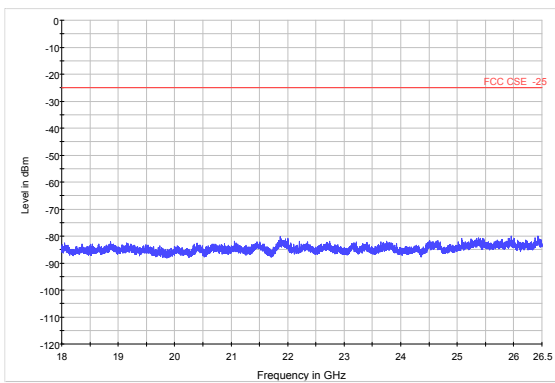

LTE Band 7 20MHz CH-Low 18GHz~26.5GHz

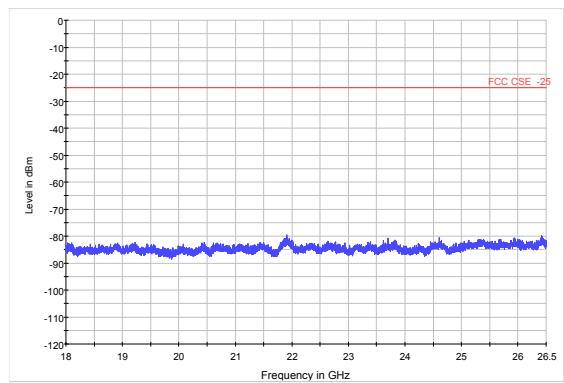





LTE Band 7 20MHz CH-Middle 30MHz~3GHz

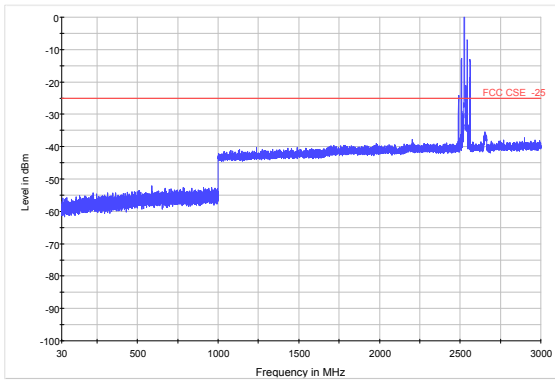

LTE Band 7 20MHz CH-High 30MHz~3GHz

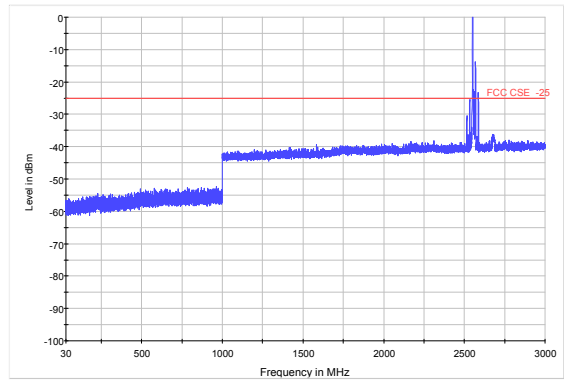

LTE Band 7 20MHz CH-Middle 3GHz~18GHz

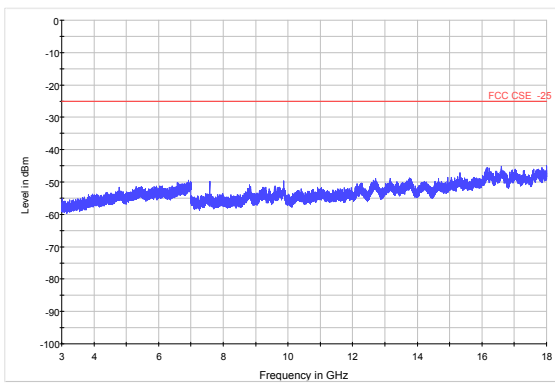

LTE Band 7 20MHz CH-High 3GHz~18GHz

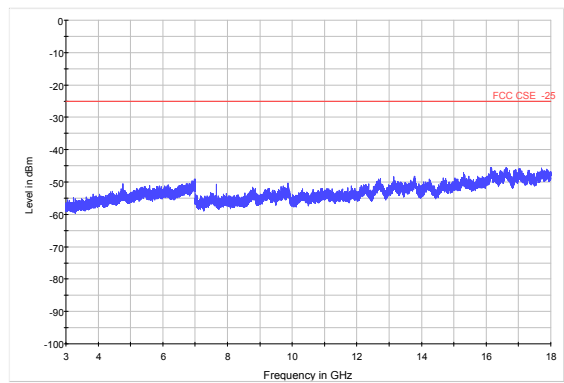

LTE Band 7 20MHz CH-Middle 18GHz~26.5GHz

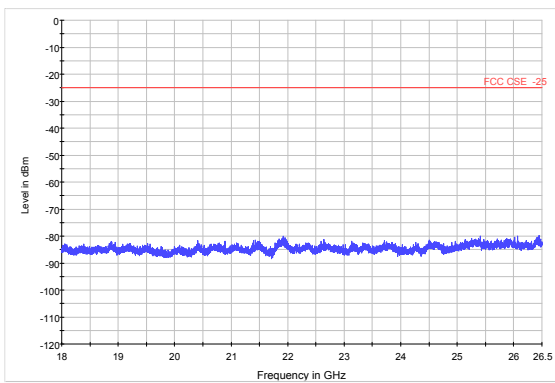

LTE Band 7 20MHz CH-High 18GHz~26.5GHz

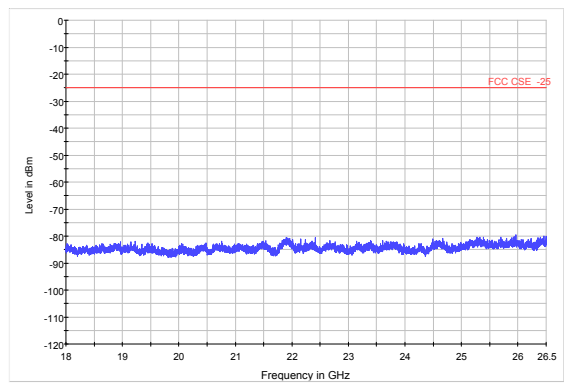



LTE Band 41 5MHz CH-Low 30MHz~3GHz

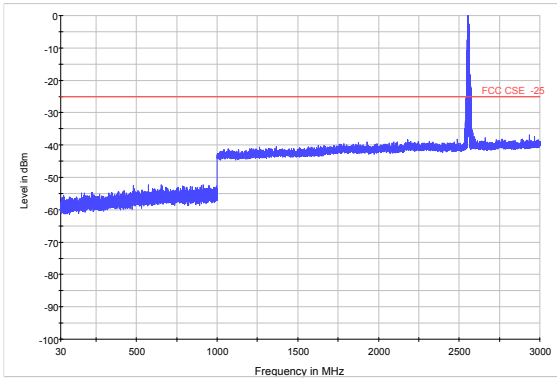

LTE Band 41 5MHz CH-Middle 30MHz~3GHz

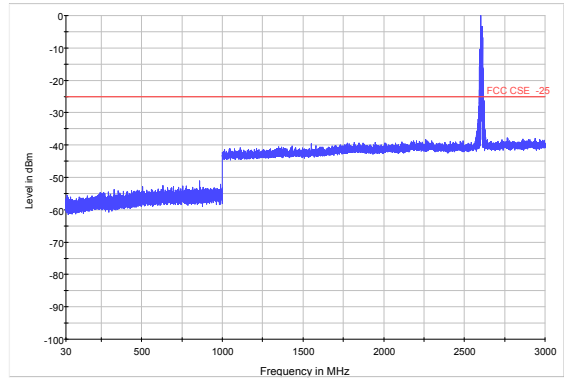

LTE Band 41 5MHz CH427235 3GHz~18GHz

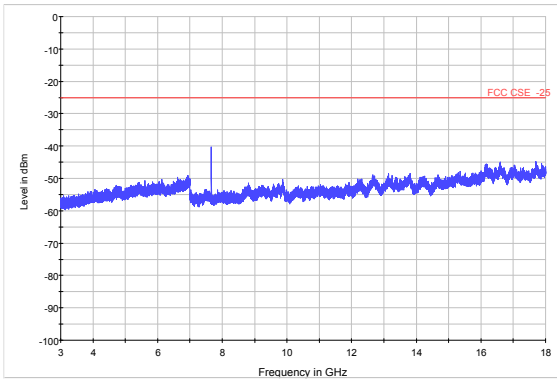

LTE Band 41 5MHz CH-Middle 3GHz~18GHz

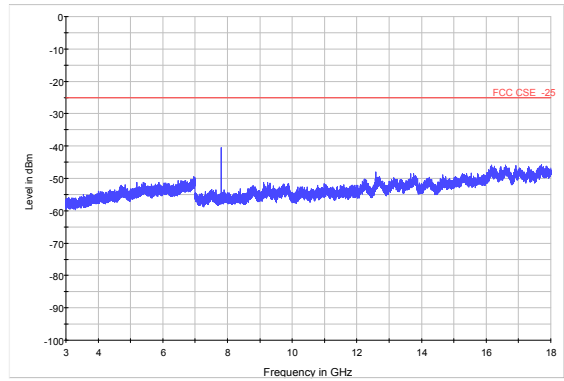

LTE Band 41 5MHz CH-Low 18GHz~26.5GHz

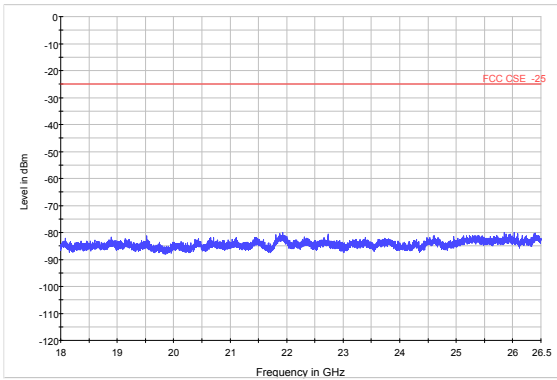

LTE Band 41 5MHz CH-Middle 18GHz~26.5GHz

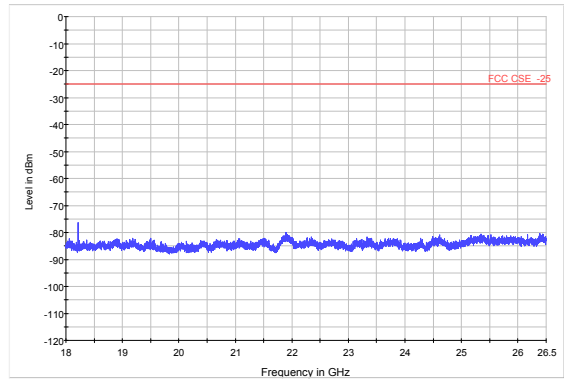



LTE Band 41 5MHz CH-High 30MHz~3GHz

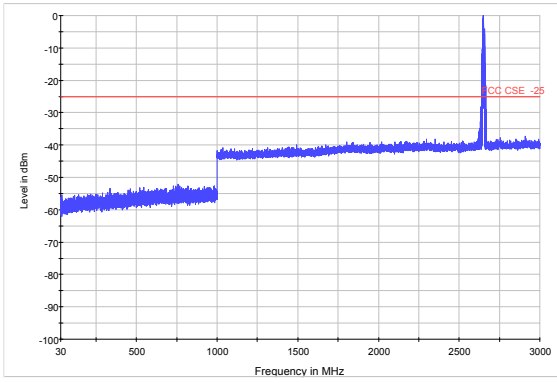

LTE Band 41 10MHz CH-Low 30MHz~3GHz

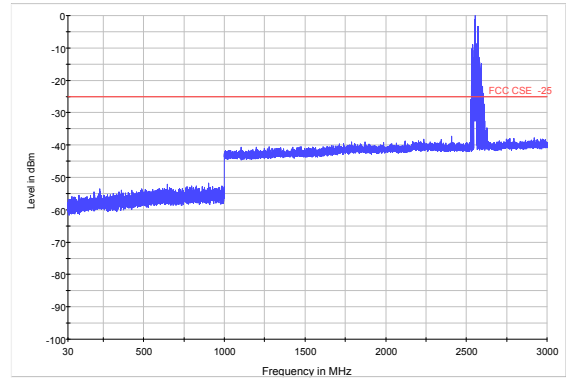

LTE Band 41 5MHz CH-High 3GHz~18GHz

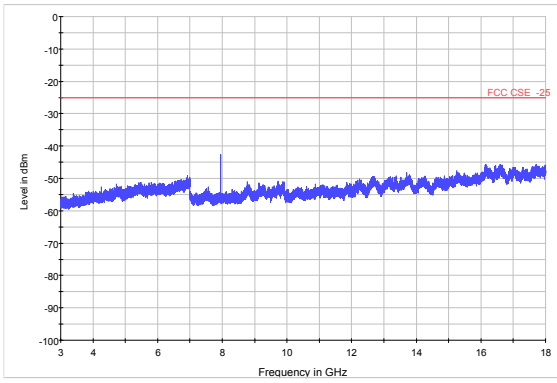

LTE Band 41 10MHz CH-Low 3GHz~18GHz

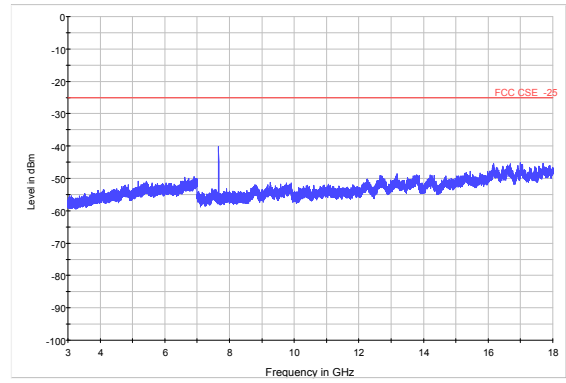

LTE Band 41 5MHz CH-High 18GHz~26.5GHz

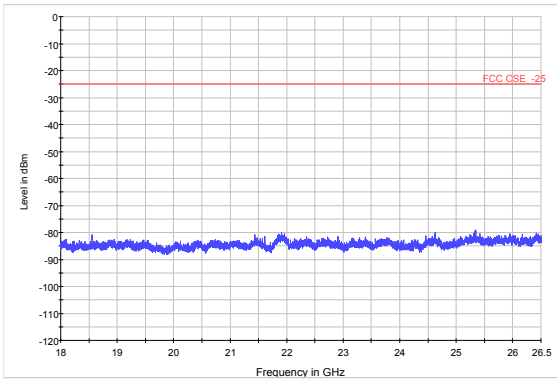

LTE Band 41 10MHz CH-Low 18GHz~26.5GHz

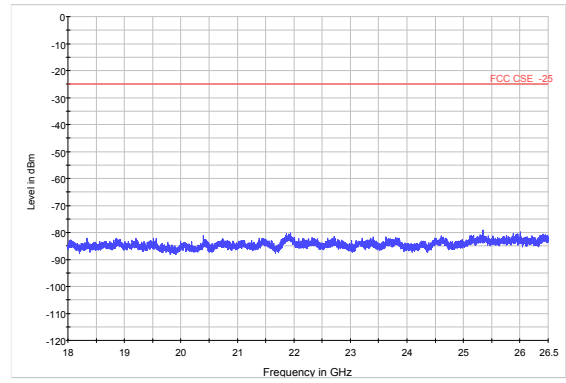



LTE Band 41 10MHz CH-Middle 30MHz~3GHz

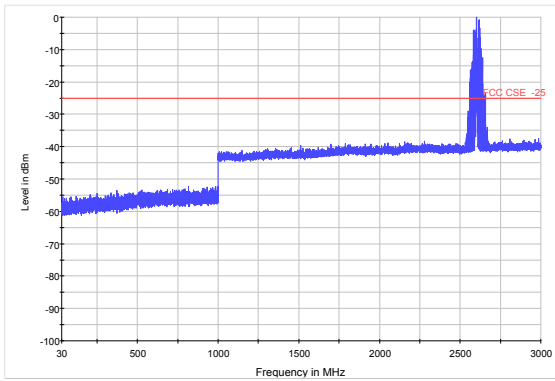

LTE Band 41 10MHz CH-High 30MHz~3GHz

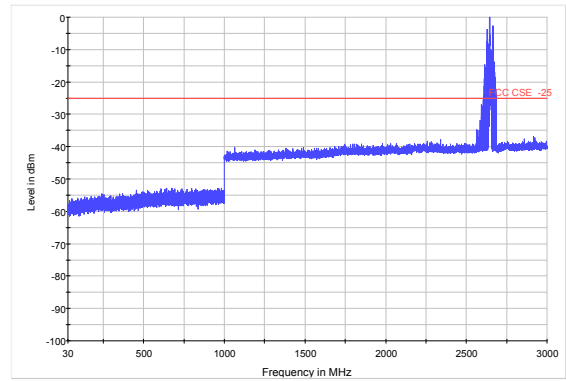

LTE Band 41 10MHz CH-Middle 3GHz~18GHz

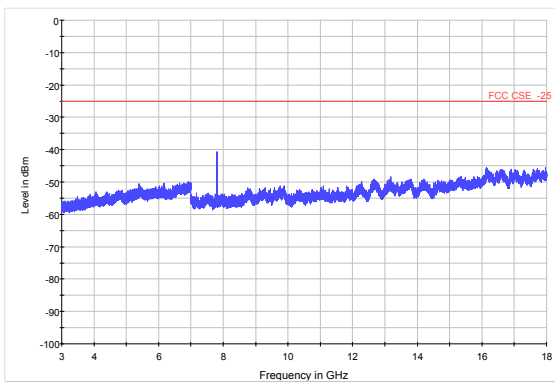

LTE Band 41 10MHz CH-High 3GHz~18GHz

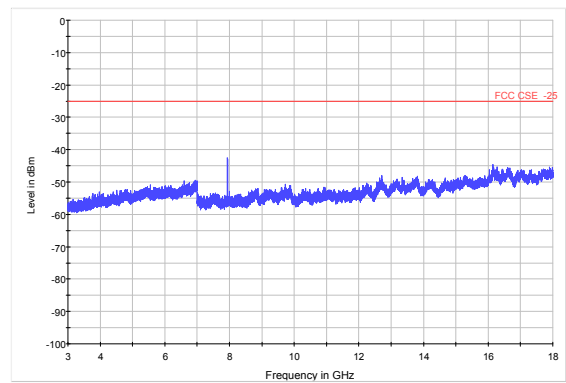

LTE Band 41 10MHz CH-Middle 18GHz~26.5GHz

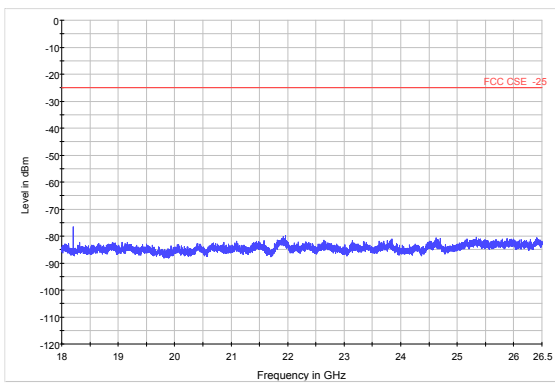

LTE Band 41 10MHz CH-High 18GHz~26.5GHz

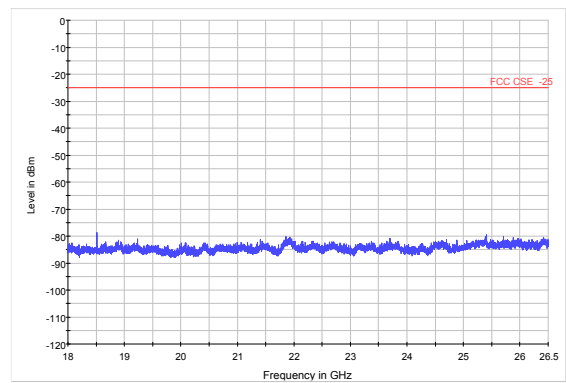



LTE Band 41 15MHz CH-Low 30MHz~3GHz

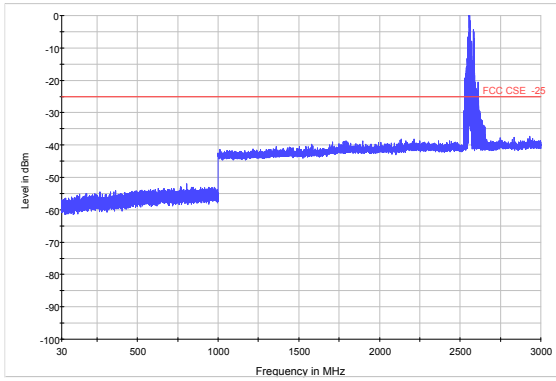

LTE Band 41 15MHz CH-Middle 30MHz~3GHz

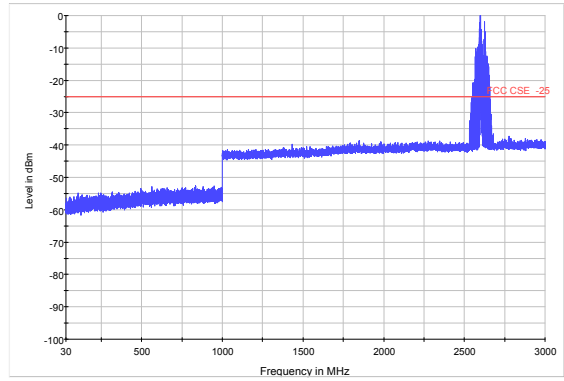

LTE Band 41 15MHz CH-Low 3GHz~18GHz

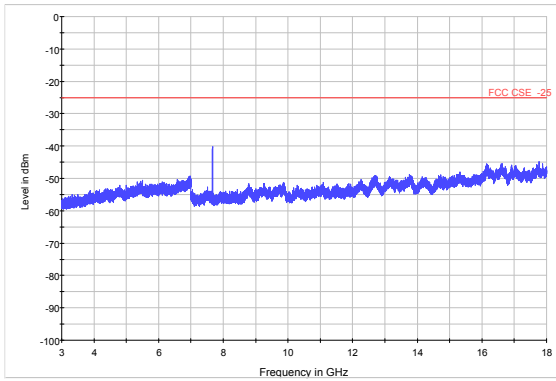

LTE Band 41 15MHz CH-Middle 3GHz~18GHz

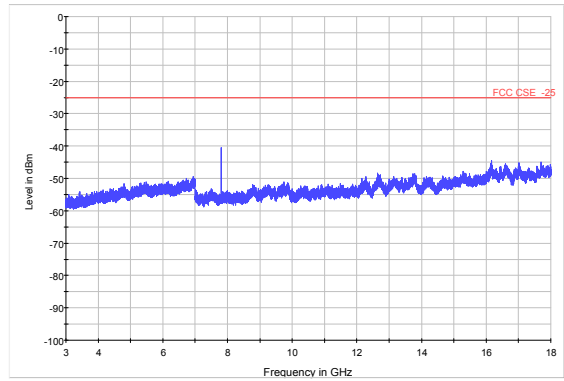

LTE Band 41 15MHz CH-Low 18GHz~26.5GHz

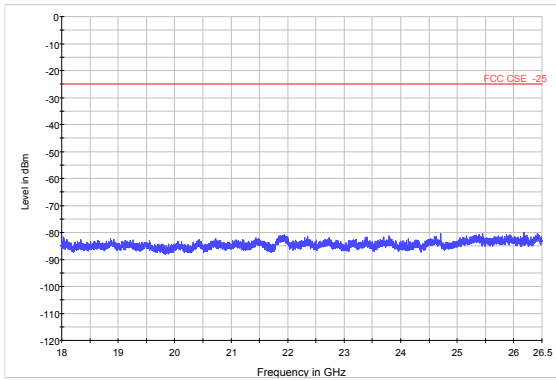

LTE Band4115MHz CH-Middle 18GHz~26.5GHz

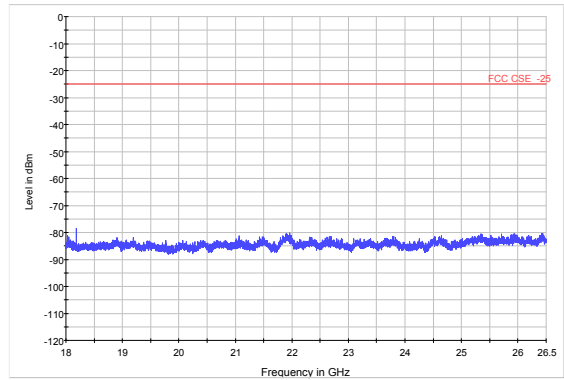



LTE Band 41 15MHz CH-High 30MHz~3GHz

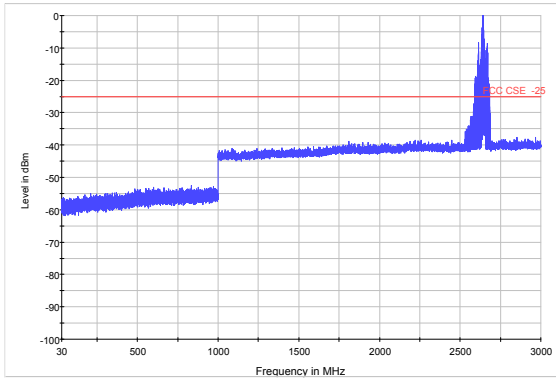

LTE Band 41 20MHz CH-Low 30MHz~3GHz

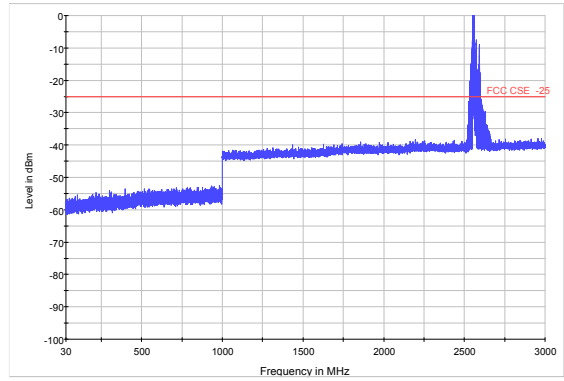

LTE Band 41 15MHz CH-High 3GHz~18GHz

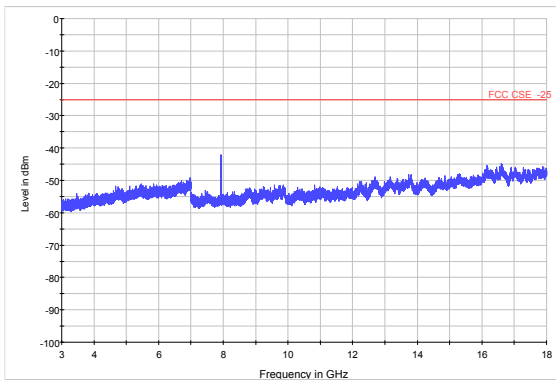

LTE Band 41 20MHz CH-Low 3GHz~18GHz

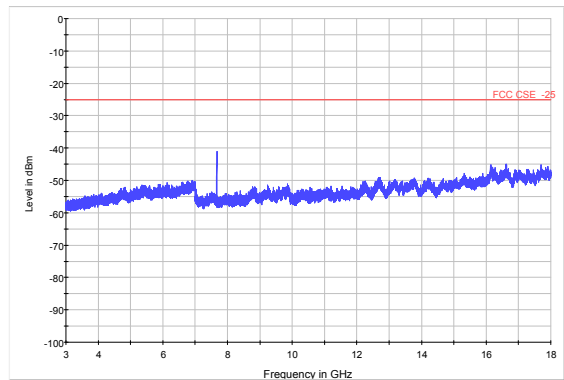

LTE Band 41 15MHz CH-High 18GHz~26.5GHz

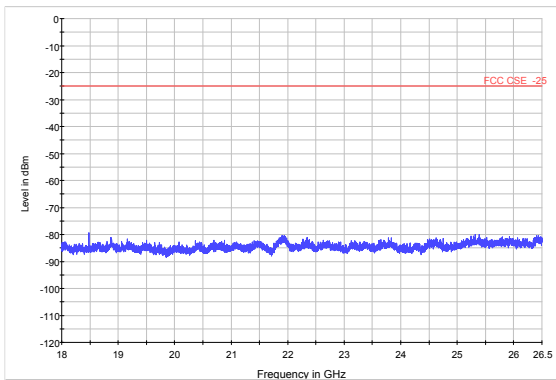

LTE Band 41 20MHz CH-Low 18GHz~26.5GHz

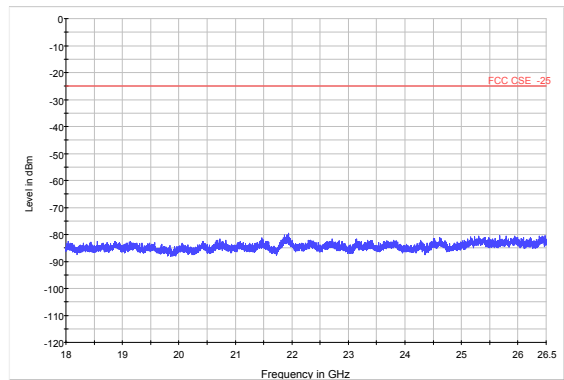

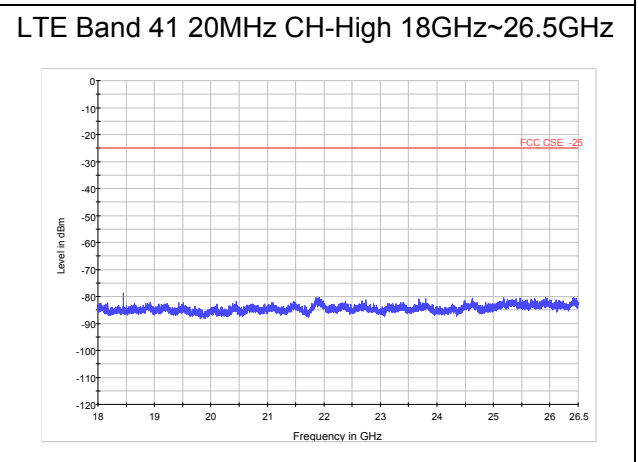
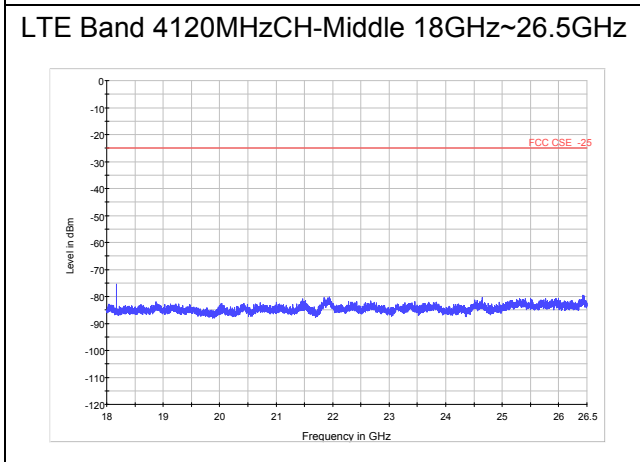
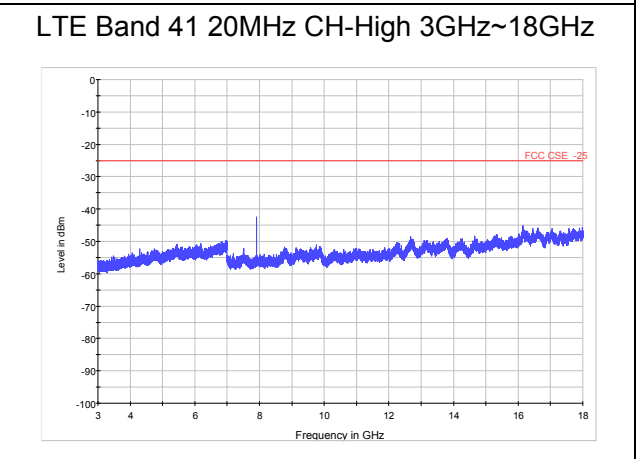
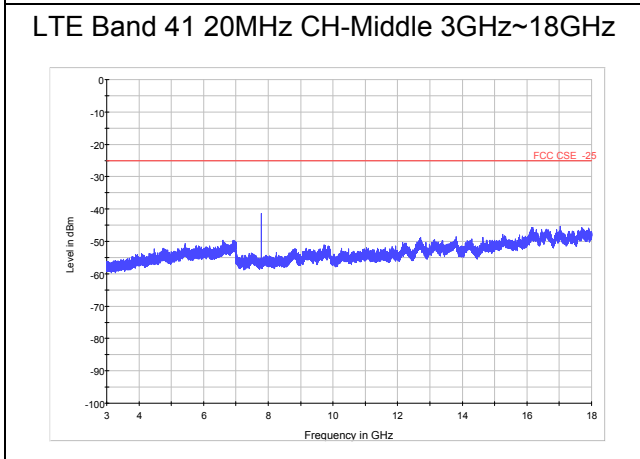
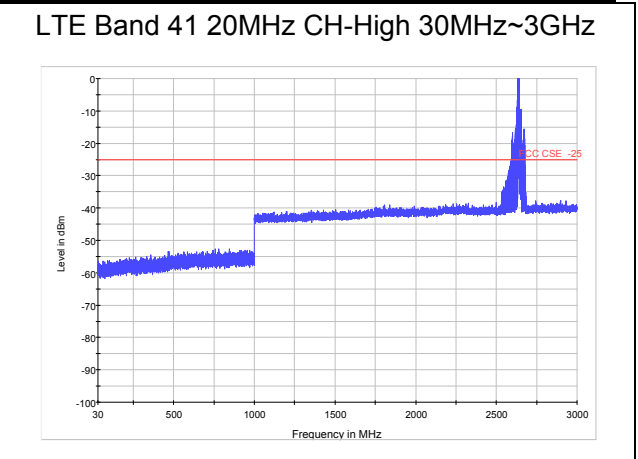
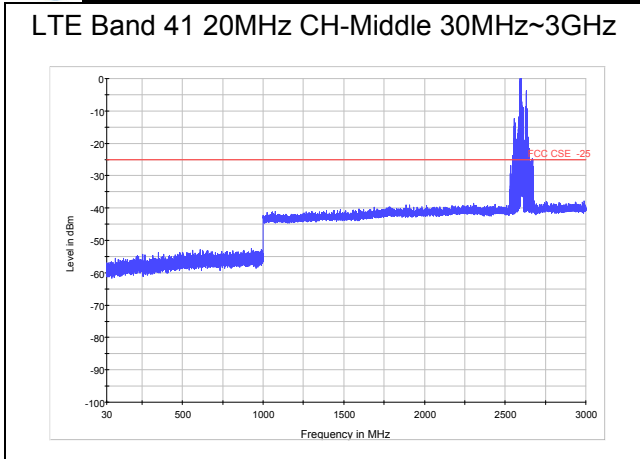

If disturbances were found more than 20dB below limit, the mark is not required for the EUT. The signal beyond the limit is carrier in the following plots.

Test Data File Name	Frequency (MHz)	Level (dBm)	Limit (dBm)	Margin (dB)
LTE B41 5M RB1_CH-Low_3-18GHz	7666.1	-40.40	-25	15.40
LTE B41 5M RB1_CH-Middle_3-18GHz	7808.6	-40.50	-25	15.50
LTE B41 5M RB1_CH- High_3-18GHz	7951.1	-42.70	-25	17.70
LTE B41 10M RB1_CH-Low_3-18GHz	7666.9	-40.06	-25	15.06
LTE B41 10M RB1_CH-Middle_3-18GHz	7801.8	-40.63	-25	15.63



LTE B41 10M RB1_CH- High 3-18GHz	7936.9	-42.49	-25	17.49
LTE B41 15M RB1_CH-Low_3-18GHz	7667.6	-40.40	-25	15.40
LTE B41 15M RB1_CH-Middle_3-18GHz	7795.1	-40.47	-25	15.47
LTE B41 15M RB1_CH-High_3-18GHz	7922.6	-41.13	-25	16.13
LTE B41 20M RB1_CH-Low_3-18GHz	7668.4	-41.06	-25	16.06
LTE B41 20M RB1_CH-Middle_3-18GHz	7788.8	-41.30	-25	16.30
LTE B41 20M RB1_CH-High_3-18GHz	7908.4	-42.50	-25	17.50



## 4.8 Radiates Spurious Emission

### Ambient condition

Temperature	Relative humidity	Pressure
23°C ~25°C	45%~50%	101.5kPa

### Method of Measurement

- The testing follows ANSI C63.26 (2015) Section 5.5.2.3.
- Above 30MHz: The EUT is placed on a turntable 0.8 meters above the ground in the chamber, 3 meter away from the antenna. The maximal emission value is acquired by adjusting the antenna height, polarisation and turntable azimuth. Normally, the height range of antenna is 1 m to 4 m, the azimuth range of turntable is 0° to 360°, and the receive antenna has two polarizations Vertical (V) and Horizontal (H). Above 1GHz: (Note: the FCC's permission to use 1.5m as an alternative per TCBC Conf call of Dec. 2, 2014.) The EUT is placed on a turntable 1.5 meters above the ground in the chamber, 3 meter away from the antenna. The maximal emission value is acquired by adjusting the antenna height, polarisation and turntable azimuth. Normally, the height range of antenna is 1 m to 4 m, the azimuth range of turntable is 0° to 360°, and the receive antenna has two polarizations Vertical (V) and Horizontal (H).
- A log-periodic antenna or double-ridged waveguide horn antenna shall be substituted in place of the EUT. The log-periodic antenna will be driven by a signal generator and the level will be adjusted till the same power value on the spectrum analyzer or receiver. The level of the spurious emissions can be calculated through the level of the signal generator, cable loss, the gain of the substitution antenna and the reading of the spectrum analyzer or receiver.
- The EUT is then put into continuously transmitting mode at its maximum power level during the test. Set Test Receiver or Spectrum RBW=1MHz, VBW=3MHz, And the maximum value of the receiver should be recorded as (Pr).
- The EUT shall be replaced by a substitution antenna. In the chamber, an substitution antenna for the frequency band of interest is placed at the reference point of the chamber. An RF Signal source for the frequency band of interest is connected to the substitution antenna with a cable that has been constructed to not interfere with the radiation pattern of the antenna. A power (PMea) is applied to the input of the substitution antenna, and adjust the level of the signal generator output until the value of the receiver reach the previously recorded (Pr). The power of signal source (PMea) is recorded. The test should be performed by rotating the test item and adjusting the receiving antenna polarization.
- A amplifier should be connected to the Signal Source output port. And the cable should be connect between the Amplifier and the Substitution Antenna. The cable loss (Pcl) ,the Substitution Antenna Gain (Ga) and the Amplifier Gain (PAg) should be recorded after test.
- The measurement results are obtained as described below:  

$$\text{Power(EIRP)} = \text{PMea} - \text{PAg} - \text{Pcl} + \text{Ga}$$
The measurement results are amend as described below:  

$$\text{Power(EIRP)} = \text{PMea} - \text{Pcl} + \text{Ga}$$
- This value is EIRP since the measurement is calibrated using an antenna of known gain (2.15 dBi) and known input power. ERP can be calculated from EIRP by subtracting the gain of the dipole,  $\text{ERP} = \text{EIRP} - 2.15\text{dBi}$ .

**Test setup**

**30MHz~~~ 1GHz**

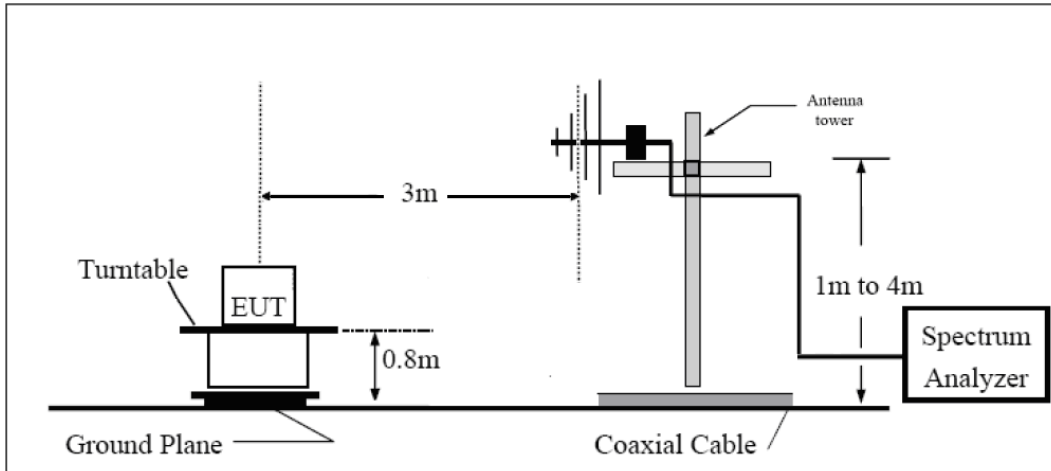

**Above 1GHz**

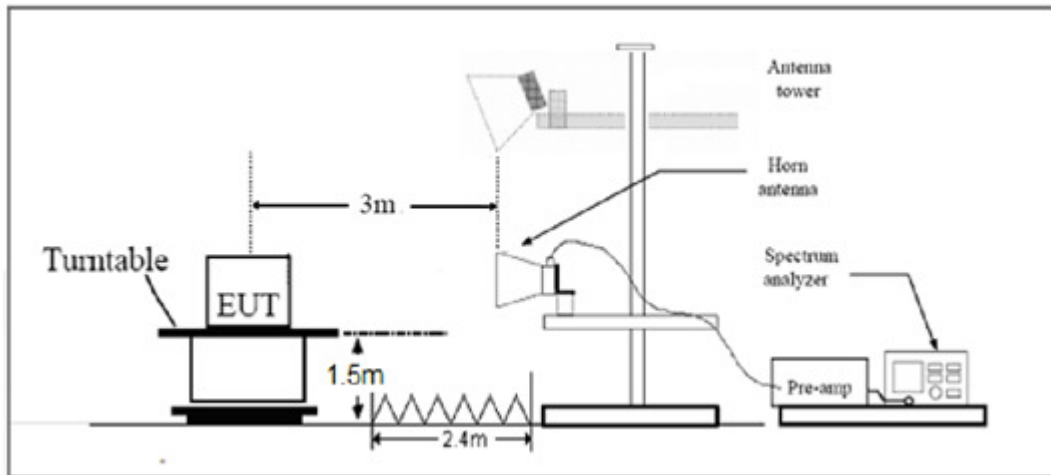

Note: Area side:2.4mX3.6m

The radiated emission was measured in the following position: EUT stand-up position (Z axis), lie-down position (X, Y axis). The worst emission was found in stand-up position (Z axis) and the worst case was recorded.

**Limits**

Rule Part 27.53(m) 55 + 10 log (P) dB on all frequencies more than X megahertz from the channel edge, where X is the greater of 6 megahertz or the actual emission bandwidth as defined in paragraph (m)(4) of this section.

LTE -7 Limit	-25 dBm
--------------	---------

**Measurement Uncertainty**

The assessed measurement uncertainty to ensure 95% confidence level for the normal distribution is with the coverage factor  $k = \pm 1.96$ ,  $U = \pm 3.55$  dB.

**Test Result**

LTE Band 7 QPSK 5MHz CH-Low, RB 1

Harmonic	Frequency (MHz)	SG (dBm)	Cable Loss (dB)	Gain (dBi)	Antenna Polarization	EIRP Level (dBm)	Limit (dBm)	Margin (dB)	Azimuth (deg)
2	5005.0	-59.05	2.00	9.15	Vertical	-51.9	-25.0	26.9	225
3	7507.5	-55.25	2.50	11.35	Vertical	-46.4	-25.0	21.4	135
4	10010.0	-57.75	4.20	12.05	Vertical	-49.9	-25.0	24.9	45
5	12512.5	-54.45	5.20	12.85	Vertical	-46.8	-25.0	21.8	0
6	15015.0	-53.53	5.50	14.23	Vertical	-44.8	-25.0	19.8	45
7	17517.5	-50.95	5.70	14.15	Vertical	-42.5	-25.0	17.5	90
8	20020.0	-49.26	6.30	13.76	Vertical	-41.8	-25.0	16.8	135
9	22522.5	-48.25	6.80	14.05	Vertical	-41.0	-25.0	16.0	45
10	25025.0	-48.14	6.90	14.84	Vertical	-40.2	-25.0	15.2	315

Note: 1. The other Spurious RF Radiated emissions level is no more than noise floor.

2. The worst emission was found in the antenna is vertical position.

LTE Band 7 QPSK 5MHz CH-Middle, RB 1

Harmonic	Frequency (MHz)	SG (dBm)	Cable Loss (dB)	Gain (dBi)	Antenna Polarization	EIRP Level (dBm)	Limit (dBm)	Margin (dB)	Azimuth (deg)
2	5070.0	-56.35	2.00	9.15	Vertical	-49.2	-25.0	24.2	180
3	7605.0	-54.95	2.50	11.35	Vertical	-46.1	-25.0	21.1	270
4	10140.0	-55.75	4.20	12.05	Vertical	-47.9	-25.0	22.9	135
5	12675.0	-52.75	5.20	12.85	Vertical	-45.1	-25.0	20.1	225
6	15210.0	-52.23	5.50	14.23	Vertical	-43.5	-25.0	18.5	135
7	17745.0	-49.55	5.70	14.15	Vertical	-41.1	-25.0	16.1	45
8	20280.0	-48.06	6.30	13.76	Vertical	-40.6	-25.0	15.6	0
9	22815.0	-46.85	6.80	14.05	Vertical	-39.6	-25.0	14.6	45
10	25350.0	-46.44	6.90	14.84	Vertical	-38.5	-25.0	13.5	90

Note: 1. The other Spurious RF Radiated emissions level is no more than noise floor.

2. The worst emission was found in the antenna is vertical position.

**LTE Band 7 QPSK 5MHz CH-High, RB 1**

Harmonic	Frequency (MHz)	SG (dBm)	Cable Loss (dB)	Gain (dBi)	Antenna Polarization	EIRP Level (dBm)	Limit (dBm)	Margin (dB)	Azimuth (deg)
2	5135.0	-57.45	2.00	9.15	Vertical	-50.3	-25.0	25.3	0
3	7702.5	-55.05	2.50	11.35	Vertical	-46.2	-25.0	21.2	45
4	10270.0	-56.15	4.20	12.05	Vertical	-48.3	-25.0	23.3	45
5	12837.5	-54.35	5.20	12.85	Vertical	-46.7	-25.0	21.7	180
6	15405.0	-51.13	5.50	14.23	Vertical	-42.4	-25.0	17.4	270
7	17972.5	-49.65	5.70	14.15	Vertical	-41.2	-25.0	16.2	135
8	20540.0	-47.96	6.30	13.76	Vertical	-40.5	-25.0	15.5	225
9	23107.5	-47.05	6.80	14.05	Vertical	-39.8	-25.0	14.8	135
10	25675.0	-46.14	6.90	14.84	Vertical	-38.2	-25.0	13.2	45

- Note: 1. The other Spurious RF Radiated emissions level is no more than noise floor.  
 2. The worst emission was found in the antenna is vertical position.

**LTE Band 7 QPSK 10MHz CH-Low, RB 1**

Harmonic	Frequency (MHz)	SG (dBm)	Cable Loss (dB)	Gain (dBi)	Antenna Polarization	EIRP Level (dBm)	Limit (dBm)	Margin (dB)	Azimuth (deg)
2	5010.0	-59.95	2.00	9.15	Vertical	-52.8	-25.0	27.8	45
3	7515.0	-55.65	2.50	11.35	Vertical	-46.8	-25.0	21.8	180
4	10020.0	-58.15	4.20	12.05	Vertical	-50.3	-25.0	25.3	90
5	12525.0	-53.05	5.20	12.85	Vertical	-45.4	-25.0	20.4	0
6	15030.0	-52.53	5.50	14.23	Vertical	-43.8	-25.0	18.8	45
7	17535.0	-51.35	5.70	14.15	Vertical	-42.9	-25.0	17.9	45
8	20040.0	-49.56	6.30	13.76	Vertical	-42.1	-25.0	17.1	225
9	22545.0	-48.85	6.80	14.05	Vertical	-41.6	-25.0	16.6	135
10	25050.0	-48.24	6.90	14.84	Vertical	-40.3	-25.0	15.3	45

- Note: 1. The other Spurious RF Radiated emissions level is no more than noise floor.  
 2. The worst emission was found in the antenna is vertical position.

**LTE Band 7 QPSK 10MHz CH-Middle, RB 1**

Harmonic	Frequency (MHz)	SG (dBm)	Cable Loss (dB)	Gain (dBi)	Antenna Polarization	EIRP Level (dBm)	Limit (dBm)	Margin (dB)	Azimuth (deg)
2	5070.0	-57.15	2.00	9.15	Vertical	-50.0	-25.0	25.0	45
3	7605.0	-57.65	2.50	11.35	Vertical	-48.8	-25.0	23.8	180
4	10140.0	-54.65	4.20	12.05	Vertical	-46.8	-25.0	21.8	90
5	12675.0	-53.75	5.20	12.85	Vertical	-46.1	-25.0	21.1	0
6	15210.0	-52.33	5.50	14.23	Vertical	-43.6	-25.0	18.6	45
7	17745.0	-52.45	5.70	14.15	Vertical	-44.0	-25.0	19.0	45
8	20280.0	-49.96	6.30	13.76	Vertical	-42.5	-25.0	17.5	180
9	22815.0	-48.85	6.80	14.05	Vertical	-41.6	-25.0	16.6	225
10	25350.0	-48.44	6.90	14.84	Vertical	-40.5	-25.0	15.5	135

Note: 1.The other Spurious RF Radiated emissions level is no more than noise floor.

2. The worst emission was found in the antenna is vertical position.

**LTE Band 7 QPSK 10MHz CH-High, RB 1**

Harmonic	Frequency (MHz)	SG (dBm)	Cable Loss (dB)	Gain (dBi)	Antenna Polarization	EIRP Level (dBm)	Limit (dBm)	Margin (dB)	Azimuth (deg)
2	5130.0	-58.25	2.00	10.15	Vertical	-50.1	-25.0	25.1	270
3	7695.0	-55.45	2.50	11.35	Vertical	-46.6	-25.0	21.6	45
4	10260.0	-57.35	4.20	12.05	Vertical	-49.5	-25.0	24.5	180
5	12825.0	-55.85	5.20	14.85	Vertical	-46.2	-25.0	21.2	90
6	15390.0	-52.33	5.50	13.23	Vertical	-44.6	-25.0	19.6	0
7	17955.0	-48.65	5.70	12.15	Vertical	-42.2	-25.0	17.2	45
8	20520.0	-48.66	6.30	13.76	Vertical	-41.2	-25.0	16.2	45
9	23085.0	-47.85	6.80	14.05	Vertical	-40.6	-25.0	15.6	225
10	25650.0	-46.54	6.90	14.84	Vertical	-38.6	-25.0	13.6	135

Note: 1.The other Spurious RF Radiated emissions level is no more than noise floor.

2. The worst emission was found in the antenna is vertical position.

**LTE Band 7 QPSK 15MHz CH-Low, RB 1**

Harmonic	Frequency (MHz)	SG (dBm)	Cable Loss (dB)	Gain (dBi)	Antenna Polarization	EIRP Level (dBm)	Limit (dBm)	Margin (dB)	Azimuth (deg)
2	5015.0	-58.65	2.00	10.15	Vertical	-50.5	-25.0	25.5	270
3	7522.5	-55.95	2.50	11.35	Vertical	-47.1	-25.0	22.1	45
4	10030.0	-56.25	4.20	12.05	Vertical	-48.4	-25.0	23.4	180
5	12537.5	-55.95	5.20	14.85	Vertical	-46.3	-25.0	21.3	90
6	15045.0	-49.93	5.50	13.23	Vertical	-42.2	-25.0	17.2	0
7	17552.5	-47.45	5.70	12.15	Vertical	-41.0	-25.0	16.0	45
8	20060.0	-47.66	6.30	13.76	Vertical	-40.2	-25.0	15.2	45
9	22567.5	-46.45	6.80	14.05	Vertical	-39.2	-25.0	14.2	180
10	25075.0	-46.44	6.90	14.84	Vertical	-38.5	-25.0	13.5	225

Note: 1.The other Spurious RF Radiated emissions level is no more than noise floor.

2. The worst emission was found in the antenna is vertical position.

**LTE Band 7 QPSK 15MHz CH-Middle, RB 1**

Harmonic	Frequency (MHz)	SG (dBm)	Cable Loss (dB)	Gain (dBi)	Antenna Polarization	EIRP Level (dBm)	Limit (dBm)	Margin (dB)	Azimuth (deg)
2	5070.0	43.05	2.00	10.15	Vertical	51.2	-25.0	-76.2	180
3	7605.0	-56.75	2.50	11.35	Vertical	-47.9	-25.0	22.9	270
4	10140.0	-56.25	4.20	12.05	Vertical	-48.4	-25.0	23.4	45
5	12675.0	-56.25	5.20	14.85	Vertical	-46.6	-25.0	21.6	180
6	15210.0	-51.93	5.50	13.23	Vertical	-44.2	-25.0	19.2	90
7	17745.0	-47.85	5.70	12.15	Vertical	-41.4	-25.0	16.4	0
8	20280.0	-49.56	6.30	13.76	Vertical	-42.1	-25.0	17.1	45
9	22815.0	-48.75	6.80	14.05	Vertical	-41.5	-25.0	16.5	45
10	25350.0	-49.24	6.90	14.84	Vertical	-41.3	-25.0	16.3	180

Note: 1.The other Spurious RF Radiated emissions level is no more than noise floor.

2. The worst emission was found in the antenna is vertical position.

**LTE Band 7 QPSK 15MHz CH-High, RB 1**

Harmonic	Frequency (MHz)	SG (dBm)	Cable Loss (dB)	Gain (dBi)	Antenna Polarization	EIRP Level (dBm)	Limit (dBm)	Margin (dB)	Azimuth (deg)
2	5125.0	-60.45	2.00	10.15	Vertical	-52.3	-25.0	27.3	315
3	7687.5	-55.75	2.50	11.35	Vertical	-46.9	-25.0	21.9	270
4	10250.0	-58.95	4.20	12.05	Vertical	-51.1	-25.0	26.1	180
5	12812.5	-55.25	5.20	14.85	Vertical	-45.6	-25.0	20.6	270
6	15375.0	-50.93	5.50	13.23	Vertical	-43.2	-25.0	18.2	45
7	17937.5	-48.05	5.70	12.15	Vertical	-41.6	-25.0	16.6	180
8	20500.0	-48.46	6.30	13.76	Vertical	-41.0	-25.0	16.0	90
9	23062.5	-47.75	6.80	14.05	Vertical	-40.5	-25.0	15.5	0
10	25625.0	-47.54	6.90	14.84	Vertical	-39.6	-25.0	14.6	45

Note: 1.The other Spurious RF Radiated emissions level is no more than noise floor.

2. The worst emission was found in the antenna is vertical position.

**LTE Band 7 QPSK 20MHz CH-Low, RB 1**

Harmonic	Frequency (MHz)	SG (dBm)	Cable Loss (dB)	Gain (dBi)	Antenna Polarization	EIRP Level (dBm)	Limit (dBm)	Margin (dB)	Azimuth (deg)
2	5020.0	-59.95	2.00	10.15	Vertical	-51.8	-25.0	26.8	90
3	7530.0	-56.35	2.50	11.35	Vertical	-47.5	-25.0	22.5	135
4	10040.0	-56.15	4.20	12.05	Vertical	-48.3	-25.0	23.3	45
5	12550.0	-56.05	5.20	14.85	Vertical	-46.4	-25.0	21.4	315
6	15060.0	-53.43	5.50	13.23	Vertical	-45.7	-25.0	20.7	270
7	17570.0	-48.75	5.70	12.15	Vertical	-42.3	-25.0	17.3	180
8	20080.0	-46.06	6.30	13.76	Vertical	-38.6	-25.0	13.6	270
9	22590.0	-45.35	6.80	14.05	Vertical	-38.1	-25.0	13.1	45
10	25100.0	-45.14	6.90	14.84	Vertical	-37.2	-25.0	12.2	180

Note: 1.The other Spurious RF Radiated emissions level is no more than noise floor.

2. The worst emission was found in the antenna is vertical position.

**LTE Band 7 QPSK 20MHz CH-Middle, RB 1**

Harmonic	Frequency (MHz)	SG (dBm)	Cable Loss (dB)	Gain (dBi)	Antenna Polarization	EIRP Level (dBm)	Limit (dBm)	Margin (dB)	Azimuth (deg)
2	5070.0	-59.25	2.00	10.15	Vertical	-51.1	-25.0	26.1	45
3	7605.0	-56.65	2.50	11.35	Vertical	-47.8	-25.0	22.8	0
4	10140.0	-57.85	4.20	12.05	Vertical	-50.0	-25.0	25.0	45
5	12675.0	-55.55	5.20	14.85	Vertical	-45.9	-25.0	20.9	90
6	15210.0	-50.63	5.50	13.23	Vertical	-42.9	-25.0	17.9	135
7	17745.0	-47.95	5.70	12.15	Vertical	-41.5	-25.0	16.5	45
8	20280.0	-48.06	6.30	13.76	Vertical	-40.6	-25.0	15.6	315
9	22815.0	-48.25	6.80	14.05	Vertical	-41.0	-25.0	16.0	270
10	25350.0	-47.44	6.90	14.84	Vertical	-39.5	-25.0	14.5	180

Note: 1.The other Spurious RF Radiated emissions level is no more than noise floor.

2. The worst emission was found in the antenna is vertical position.

**LTE Band 7 QPSK 20MHz CH-High, RB 1**

Harmonic	Frequency (MHz)	SG (dBm)	Cable Loss (dB)	Gain (dBi)	Antenna Polarization	EIRP Level (dBm)	Limit (dBm)	Margin (dB)	Azimuth (deg)
2	5120.0	-58.75	2.00	10.15	Vertical	-50.6	-25.0	25.6	0
3	7680.0	-57.25	2.50	11.35	Vertical	-48.4	-25.0	23.4	45
4	10240.0	-55.55	4.20	12.05	Vertical	-47.7	-25.0	22.7	90
5	12800.0	-55.15	5.20	14.85	Vertical	-45.5	-25.0	20.5	135
6	15360.0	-48.53	5.50	13.23	Vertical	-40.8	-25.0	15.8	45
7	17920.0	-46.55	5.70	12.15	Vertical	-40.1	-25.0	15.1	315
8	20480.0	-47.06	6.30	13.76	Vertical	-39.6	-25.0	14.6	270
9	23040.0	-46.35	6.80	14.05	Vertical	-39.1	-25.0	14.1	180
10	25600.0	-46.44	6.90	14.84	Vertical	-38.5	-25.0	13.5	270

Note: 1.The other Spurious RF Radiated emissions level is no more than noise floor.

2. The worst emission was found in the antenna is vertical position.





## LTE Band 41 QPSK 5MHz CH-Low, RB 1

Harmonic	Frequency (MHz)	SG (dBm)	Cable Loss (dB)	Gain (dBi)	Antenna Polarization	ERP Level (dBm)	Limit (dBm)	Margin (dB)	Azimuth (deg)
2	5115.0	-59.00	2.00	9.15	Vertical	-54.0	-25.0	29.0	225
3	7672.5	-48.80	2.50	11.35	Vertical	-42.1	-25.0	17.1	135
4	10230.0	-55.30	4.20	12.05	Vertical	-49.6	-25.0	24.6	270
5	12787.5	-51.20	5.20	12.85	Vertical	-45.7	-25.0	20.7	45
6	15345.0	-51.08	5.50	14.23	Vertical	-44.5	-25.0	19.5	90
7	17902.5	-49.40	5.70	14.15	Vertical	-43.1	-25.0	18.1	0
8	20460.0	-47.61	6.30	13.76	Vertical	-42.3	-25.0	17.3	135
9	23017.5	-46.70	6.80	14.05	Vertical	-41.6	-25.0	16.6	270
10	25575.0	-46.29	6.90	14.84	Vertical	-40.5	-25.0	15.5	45

Note: 1.The other Spurious RF Radiated emissions level is no more than noise floor.

2. The worst emission was found in the antenna is vertical position.

## LTE Band 41 QPSK 5MHz CH-Middle, RB 1

Harmonic	Frequency (MHz)	SG (dBm)	Cable Loss (dB)	Gain (dBi)	Antenna Polarization	ERP Level (dBm)	Limit (dBm)	Margin (dB)	Azimuth (deg)
2	5210.0	-56.70	2.00	9.15	Vertical	-51.7	-25.0	26.7	180
3	7815.0	-47.00	2.50	11.35	Vertical	-40.3	-25.0	15.3	45
4	10420.0	-54.30	4.20	12.05	Vertical	-48.6	-25.0	23.6	135
5	13025.0	-51.70	5.20	12.85	Vertical	-46.2	-25.0	21.2	225
6	15630.0	-50.28	5.50	14.23	Vertical	-43.7	-25.0	18.7	135
7	18235.0	-47.00	5.70	14.15	Vertical	-40.7	-25.0	15.7	270
8	20840.0	-45.41	6.30	13.76	Vertical	-40.1	-25.0	15.1	45
9	23445.0	-44.60	6.80	14.05	Vertical	-39.5	-25.0	14.5	90
10	26050.0	-43.89	6.90	14.84	Vertical	-38.1	-25.0	13.1	0

Note: 1.The other Spurious RF Radiated emissions level is no more than noise floor.

2. The worst emission was found in the antenna is vertical position.

**LTE Band 41 QPSK 5MHz CH-High, RB 1**

Harmonic	Frequency (MHz)	SG (dBm)	Cable Loss (dB)	Gain (dBi)	Antenna Polarization	ERP Level (dBm)	Limit (dBm)	Margin (dB)	Azimuth (deg)
2	5305.0	-59.10	2.00	9.15	Vertical	-54.1	-25.0	29.1	90
3	7957.5	-49.10	2.50	11.35	Vertical	-42.4	-25.0	17.4	0
4	10610.0	-52.50	4.20	12.05	Vertical	-46.8	-25.0	21.8	270
5	13262.5	-51.60	5.20	12.85	Vertical	-46.1	-25.0	21.1	180
6	15915.0	-48.78	5.50	14.23	Vertical	-42.2	-25.0	17.2	45
7	18567.5	-48.40	5.70	14.15	Vertical	-42.1	-25.0	17.1	135
8	21220.0	-46.51	6.30	13.76	Vertical	-41.2	-25.0	16.2	225
9	23872.5	-43.60	6.80	14.05	Vertical	-38.5	-25.0	13.5	135
10	26525.0	-43.89	6.90	14.84	Vertical	-38.1	-25.0	13.1	270

Note: 1.The other Spurious RF Radiated emissions level is no more than noise floor.

2. The worst emission was found in the antenna is vertical position.

**LTE Band 41 QPSK 10MHz CH-Low, RB 1**

Harmonic	Frequency (MHz)	SG (dBm)	Cable Loss (dB)	Gain (dBi)	Antenna Polarization	ERP Level (dBm)	Limit (dBm)	Margin (dB)	Azimuth (deg)
2	5120.0	-59.00	2.00	9.15	Vertical	-54.0	-25.0	29.0	315
3	7680.0	-49.20	2.50	11.35	Vertical	-42.5	-25.0	17.5	90
4	10240.0	-54.50	4.20	12.05	Vertical	-48.8	-25.0	23.8	45
5	12800.0	-49.80	5.20	12.85	Vertical	-44.3	-25.0	19.3	90
6	15360.0	-49.98	5.50	14.23	Vertical	-43.4	-25.0	18.4	0
7	17920.0	-47.60	5.70	14.15	Vertical	-41.3	-25.0	16.3	270
8	20480.0	-45.81	6.30	13.76	Vertical	-40.5	-25.0	15.5	180
9	23040.0	-46.10	6.80	14.05	Vertical	-41.0	-25.0	16.0	45
10	25600.0	-44.39	6.90	14.84	Vertical	-38.6	-25.0	13.6	135

Note: 1.The other Spurious RF Radiated emissions level is no more than noise floor.

2. The worst emission was found in the antenna is vertical position.

**LTE Band 41 QPSK 10MHz CH-Middle, RB 1**

Harmonic	Frequency (MHz)	SG (dBm)	Cable Loss (dB)	Gain (dBi)	Antenna Polarization	ERP Level (dBm)	Limit (dBm)	Margin (dB)	Azimuth (deg)
2	5210.0	-58.60	2.00	9.15	Vertical	-53.6	-25.0	28.6	0
3	7815.0	-48.20	2.50	11.35	Vertical	-41.5	-25.0	16.5	90
4	10420.0	-54.40	4.20	12.05	Vertical	-48.7	-25.0	23.7	270
5	13025.0	-51.80	5.20	12.85	Vertical	-46.3	-25.0	21.3	315
6	15630.0	-49.78	5.50	14.23	Vertical	-43.2	-25.0	18.2	90
7	18235.0	-47.20	5.70	14.15	Vertical	-40.9	-25.0	15.9	45
8	20840.0	-43.91	6.30	13.76	Vertical	-38.6	-25.0	13.6	90
9	23445.0	-43.20	6.80	14.05	Vertical	-38.1	-25.0	13.1	0
10	26050.0	-43.39	6.90	14.84	Vertical	-37.6	-25.0	12.6	270

Note: 1.The other Spurious RF Radiated emissions level is no more than noise floor.

2. The worst emission was found in the antenna is vertical position.

**LTE Band 41 QPSK 10MHz CH-High, RB 1**

Harmonic	Frequency (MHz)	SG (dBm)	Cable Loss (dB)	Gain (dBi)	Antenna Polarization	ERP Level (dBm)	Limit (dBm)	Margin (dB)	Azimuth (deg)
2	5300.0	-53.30	2.00	10.15	Vertical	-47.3	-25.0	22.3	135
3	7950.0	-48.90	2.50	11.35	Vertical	-42.2	-25.0	17.2	270
4	10600.0	-52.10	4.20	12.05	Vertical	-46.4	-25.0	21.4	45
5	13250.0	-53.80	5.20	14.85	Vertical	-46.3	-25.0	21.3	0
6	15900.0	-48.58	5.50	13.23	Vertical	-43.0	-25.0	18.0	90
7	18550.0	-45.20	5.70	12.15	Vertical	-40.9	-25.0	15.9	270
8	21200.0	-44.81	6.30	13.76	Vertical	-39.5	-25.0	14.5	315
9	23850.0	-44.20	6.80	14.05	Vertical	-39.1	-25.0	14.1	90
10	26500.0	-43.99	6.90	14.84	Vertical	-38.2	-25.0	13.2	45

Note: 1.The other Spurious RF Radiated emissions level is no more than noise floor.

2. The worst emission was found in the antenna is vertical position.



## LTE Band 41 QPSK 15MHz CH-Low, RB 1

Harmonic	Frequency (MHz)	SG (dBm)	Cable Loss (dB)	Gain (dBi)	Antenna Polarization	ERP Level (dBm)	Limit (dBm)	Margin (dB)	Azimuth (deg)
2	5125.0	-54.50	2.00	10.15	Vertical	-48.5	-25.0	23.5	45
3	7687.5	-48.50	2.50	11.35	Vertical	-41.8	-25.0	16.8	90
4	10250.0	-53.50	4.20	12.05	Vertical	-47.8	-25.0	22.8	0
5	12812.5	-53.80	5.20	14.85	Vertical	-46.3	-25.0	21.3	135
6	15375.0	-47.78	5.50	13.23	Vertical	-42.2	-25.0	17.2	270
7	17937.5	-46.40	5.70	12.15	Vertical	-42.1	-25.0	17.1	45
8	20500.0	-46.81	6.30	13.76	Vertical	-41.5	-25.0	16.5	0
9	23062.5	-46.20	6.80	14.05	Vertical	-41.1	-25.0	16.1	90
10	25625.0	-45.29	6.90	14.84	Vertical	-39.5	-25.0	14.5	270

Note: 1.The other Spurious RF Radiated emissions level is no more than noise floor.

2. The worst emission was found in the antenna is vertical position.

## LTE Band 41 QPSK 15MHz CH-Middle, RB 1

Harmonic	Frequency (MHz)	SG (dBm)	Cable Loss (dB)	Gain (dBi)	Antenna Polarization	ERP Level (dBm)	Limit (dBm)	Margin (dB)	Azimuth (deg)
2	5210.0	-53.80	2.00	10.15	Vertical	-47.8	-25.0	22.8	225
3	7815.0	-47.60	2.50	11.35	Vertical	-40.9	-25.0	15.9	135
4	10420.0	-54.40	4.20	12.05	Vertical	-48.7	-25.0	23.7	270
5	13025.0	-53.70	5.20	14.85	Vertical	-46.2	-25.0	21.2	45
6	15630.0	-48.98	5.50	13.23	Vertical	-43.4	-25.0	18.4	90
7	18235.0	-45.90	5.70	12.15	Vertical	-41.6	-25.0	16.6	0
8	20840.0	-45.81	6.30	13.76	Vertical	-40.5	-25.0	15.5	135
9	23445.0	-44.60	6.80	14.05	Vertical	-39.5	-25.0	14.5	270
10	26050.0	-44.79	6.90	14.84	Vertical	-39.0	-25.0	14.0	45

Note: 1.The other Spurious RF Radiated emissions level is no more than noise floor.

2. The worst emission was found in the antenna is vertical position.

**LTE Band 41 QPSK 15MHz CH-High, RB 1**

Harmonic	Frequency (MHz)	SG (dBm)	Cable Loss (dB)	Gain (dBi)	Antenna Polarization	ERP Level (dBm)	Limit (dBm)	Margin (dB)	Azimuth (deg)
2	5295.0	-50.50	2.00	10.15	Vertical	-44.5	-25.0	19.5	180
3	7942.5	-47.90	2.50	11.35	Vertical	-41.2	-25.0	16.2	45
4	10590.0	-48.00	4.20	12.05	Vertical	-42.3	-25.0	17.3	135
5	13237.5	-53.60	5.20	14.85	Vertical	-46.1	-25.0	21.1	225
6	15885.0	-47.78	5.50	13.23	Vertical	-42.2	-25.0	17.2	135
7	18532.5	-45.20	5.70	12.15	Vertical	-40.9	-25.0	15.9	270
8	21180.0	-46.41	6.30	13.76	Vertical	-41.1	-25.0	16.1	45
9	23827.5	-44.70	6.80	14.05	Vertical	-39.6	-25.0	14.6	90
10	26475.0	-45.29	6.90	14.84	Vertical	-39.5	-25.0	14.5	0

Note: 1.The other Spurious RF Radiated emissions level is no more than noise floor.

2. The worst emission was found in the antenna is vertical position.

**LTE Band 41 QPSK 20MHz CH-Low, RB 1**

Harmonic	Frequency (MHz)	SG (dBm)	Cable Loss (dB)	Gain (dBi)	Antenna Polarization	ERP Level (dBm)	Limit (dBm)	Margin (dB)	Azimuth (deg)
2	5130.0	-55.10	2.00	10.15	Vertical	-49.1	-25.0	24.1	90
3	7695.0	-48.90	2.50	11.35	Vertical	-42.2	-25.0	17.2	0
4	10260.0	-54.30	4.20	12.05	Vertical	-48.6	-25.0	23.6	270
5	12825.0	-52.70	5.20	14.85	Vertical	-45.2	-25.0	20.2	180
6	15390.0	-48.28	5.50	13.23	Vertical	-42.7	-25.0	17.7	45
7	17955.0	-45.50	5.70	12.15	Vertical	-41.2	-25.0	16.2	135
8	20520.0	-45.91	6.30	13.76	Vertical	-40.6	-25.0	15.6	225
9	23085.0	-45.20	6.80	14.05	Vertical	-40.1	-25.0	15.1	135
10	25650.0	-44.39	6.90	14.84	Vertical	-38.6	-25.0	13.6	270

Note: 1.The other Spurious RF Radiated emissions level is no more than noise floor.

2. The worst emission was found in the antenna is vertical position.

**LTE Band 41 QPSK 20MHz CH-Middle, RB 1**

Harmonic	Frequency (MHz)	SG (dBm)	Cable Loss (dB)	Gain (dBi)	Antenna Polarization	ERP Level (dBm)	Limit (dBm)	Margin (dB)	Azimuth (deg)
2	5210.0	-55.70	2.00	10.15	Vertical	-49.7	-25.0	24.7	315
3	7815.0	-47.80	2.50	11.35	Vertical	-41.1	-25.0	16.1	90
4	10420.0	-53.60	4.20	12.05	Vertical	-47.9	-25.0	22.9	45
5	13025.0	-52.80	5.20	14.85	Vertical	-45.3	-25.0	20.3	90
6	15630.0	-48.78	5.50	13.23	Vertical	-43.2	-25.0	18.2	0
7	18235.0	-46.30	5.70	12.15	Vertical	-42.0	-25.0	17.0	270
8	20840.0	-46.81	6.30	13.76	Vertical	-41.5	-25.0	16.5	180
9	23445.0	-45.30	6.80	14.05	Vertical	-40.2	-25.0	15.2	45
10	26050.0	-45.59	6.90	14.84	Vertical	-39.8	-25.0	14.8	135

Note: 1.The other Spurious RF Radiated emissions level is no more than noise floor.

2. The worst emission was found in the antenna is vertical position.

**LTE Band 41 QPSK 20MHz CH-High, RB 1**

Harmonic	Frequency (MHz)	SG (dBm)	Cable Loss (dB)	Gain (dBi)	Antenna Polarization	ERP Level (dBm)	Limit (dBm)	Margin (dB)	Azimuth (deg)
2	5290.0	-51.50	2.00	10.15	Vertical	-45.5	-25.0	20.5	0
3	7935.0	-49.50	2.50	11.35	Vertical	-42.8	-25.0	17.8	90
4	10580.0	-48.10	4.20	12.05	Vertical	-42.4	-25.0	17.4	270
5	13225.0	-53.10	5.20	14.85	Vertical	-45.6	-25.0	20.6	315
6	15870.0	-48.78	5.50	13.23	Vertical	-43.2	-25.0	18.2	90
7	18515.0	-45.80	5.70	12.15	Vertical	-41.5	-25.0	16.5	45
8	21160.0	-46.31	6.30	13.76	Vertical	-41.0	-25.0	16.0	90
9	23805.0	-44.70	6.80	14.05	Vertical	-39.6	-25.0	14.6	0
10	26450.0	-44.29	6.90	14.84	Vertical	-38.5	-25.0	13.5	270

Note: 1.The other Spurious RF Radiated emissions level is no more than noise floor.

2. The worst emission was found in the antenna is vertical position.

## 5 Main Test Instruments

Name	Manufacturer	Type	Serial Number	Calibration Date	Expiration Time
Base Station Simulator	R&S	CMW500	113645	2017-05-14	2018-05-13
Power Splitter	Hua Xiang	SHX-GF2-2-13	10120101	2017-05-14	2018-05-13
Universal Radio Communication Tester	Agilent	E5515C	MY48367192	2017-05-14	2018-05-13
Spectrum Analyzer	Agilent	N9010A	MY47191109	2017-05-14	2018-05-13
Signal Analyzer	R&S	FSV30	100815	2016-12-16	2017-12-15
Signal generator	R&S	SMB 100A	102594	2017-05-14	2018-05-13
EMI Test Receiver	R&S	ESCI	100948	2017-05-20	2018-05-19
Trilog Antenna	SCHWARZBECK	VUBL 9163	9163-201	2014-12-06	2017-12-05
Horn Antenna	R&S	HF907	100126	2014-12-06	2017-12-05
Horn Antenna	ETS-Lindgren	3160-09	00102643	2015-01-30	2018-01-29
Climatic Chamber	Re Ce	PT-30B	20101891	2015-07-18	2018-07-17
RF Cable	Agilent	SMA 15cm	0001	2017-08-04	2018-02-03
Preamplifier	R&S	SCU18	102327	2017-06-18	2018-06-17



## ANNEX A: EUT Appearance and Test Setup

### A.1 EUT Appearance

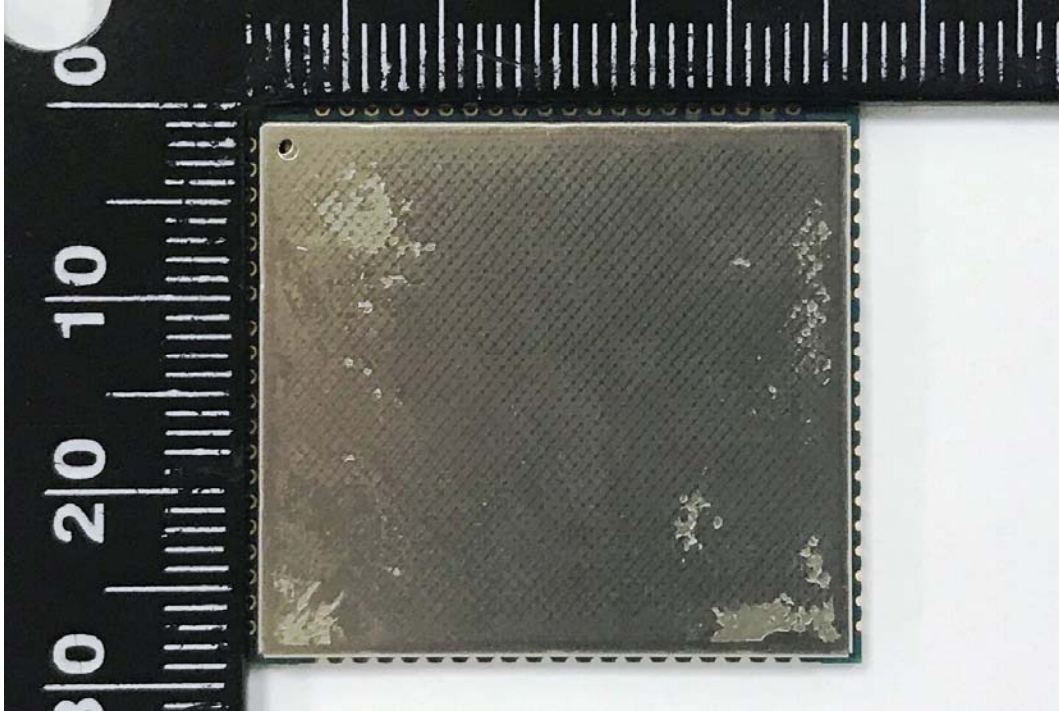

Shielding

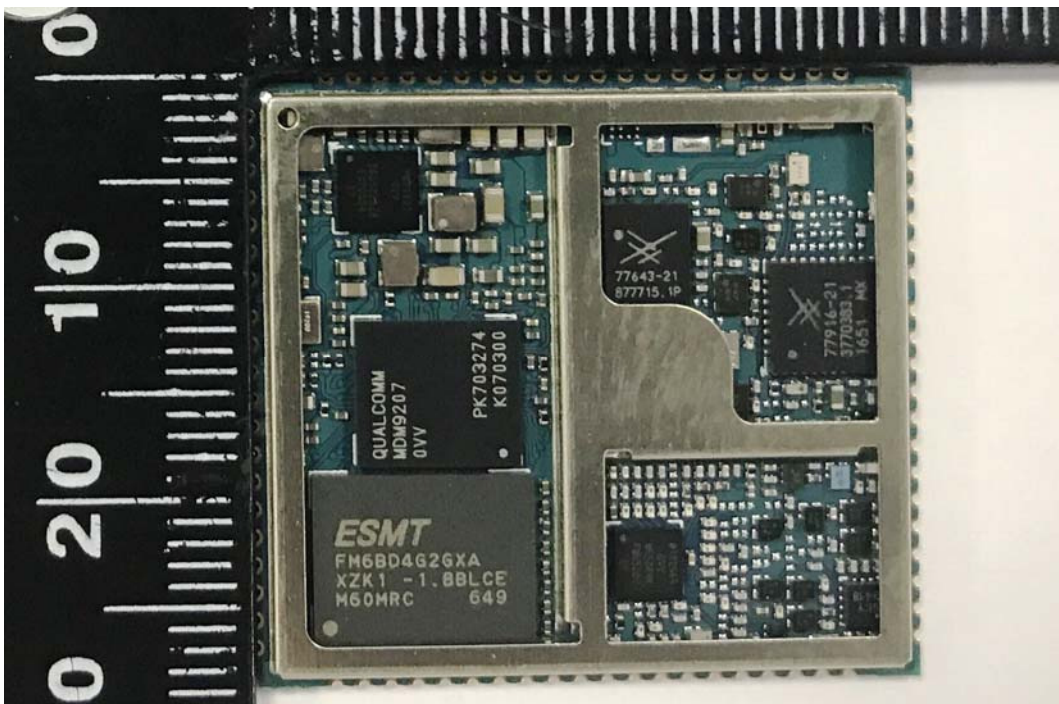

No shielding  
Front Side



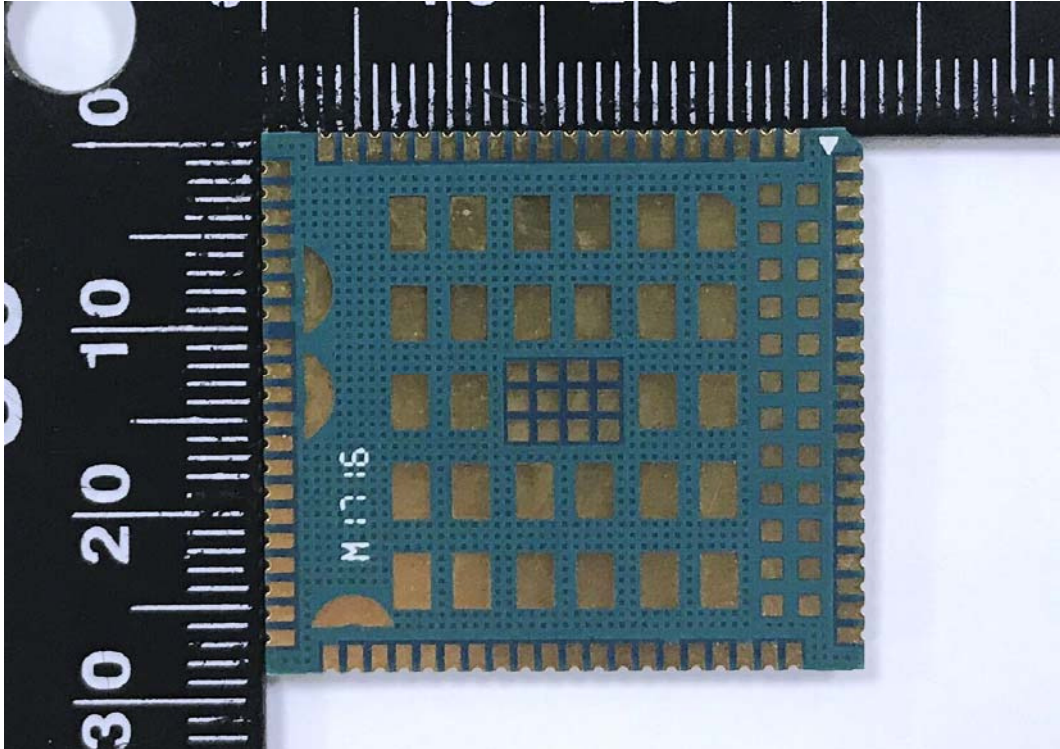

Back Side

a: EUT

Picture 1 EUT and Accessory

## A.2 Test Setup

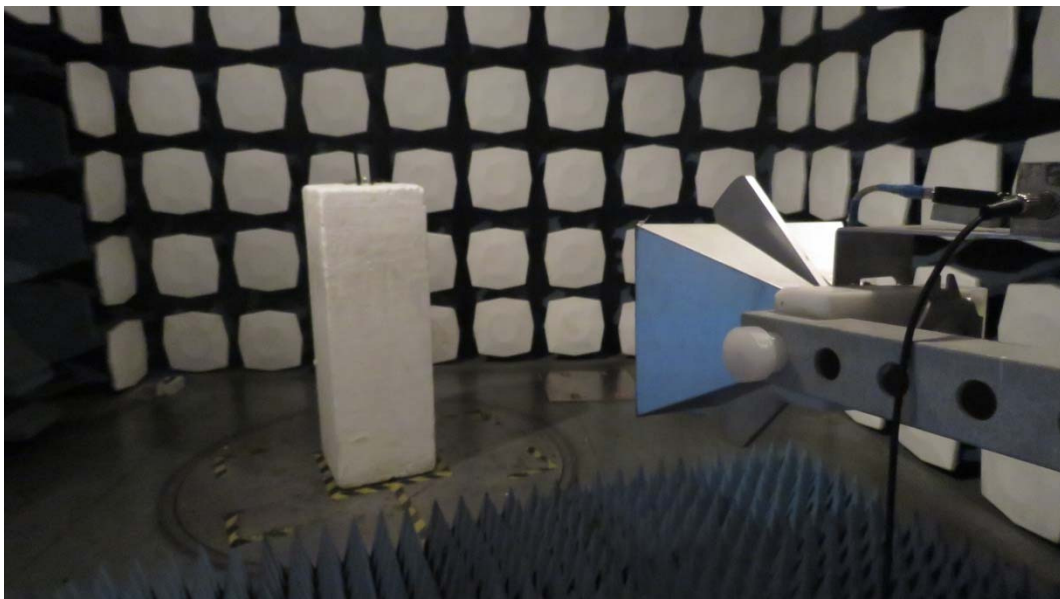

Picture 2: Radiated Spurious Emissions Test setup