

## Partial FCC Test Report

**Report No.:** RF171212C20A

**FCC ID:** XMR201706SC20A

**Test Model:** SC20-A

**Received Date:** Dec. 12, 2017

**Test Date:** Jan. 19, 2018 ~ Feb. 05, 2018

**Issued Date:** Mar. 05, 2018

**Applicant:** Quectel Wireless Solutions Co., Ltd.

**Address:** 7th Floor, Hongye Building, No. 1801 Hongmei Road, Xuhui District,  
Shanghai 200233, China

**Issued By:** Bureau Veritas Consumer Products Services (H.K.) Ltd., Taoyuan Branch

**Lab Address:** No. 47-2, 14th Ling, Chia Pau Vil., Lin Kou Dist., New Taipei City, Taiwan  
( R.O.C )

**Test Location (1):** No. 19, Hwa Ya 2nd Rd, Wen Hwa Tsuen, Kwei Shan Hsiang, Taoyuan  
Hsien 333, Taiwan, R.O.C.

**FCC Registration /  
Designation Number:** 788550 / TW0003



This report is for your exclusive use. Any copying or replication of this report to or for any other person or entity, or use of our name or trademark, is permitted only with our prior written permission. This report sets forth our findings solely with respect to the test samples identified herein. The results set forth in this report are not indicative or representative of the quality or characteristics of the lot from which a test sample was taken or any similar or identical product unless specifically and expressly noted. Our report includes all of the tests requested by you and the results thereof based upon the information that you provided to us. You have 60 days from date of issuance of this report to notify us of any material error or omission caused by our negligence, provided, however, that such notice shall be in writing and shall specifically address the issue you wish to raise. A failure to raise such issue within the prescribed time shall constitute your unqualified acceptance of the completeness of this report, the tests conducted and the correctness of the report contents. Unless specific mention, the uncertainty of measurement has been explicitly taken into account to declare the compliance or non-compliance to the specification. The report must not be used by the client to claim product certification, approval, or endorsement by TAF or any government agencies.

## Table of Contents

<b>Release Control Record .....</b>	<b>3</b>
<b>1 Certificate of Conformity .....</b>	<b>4</b>
<b>2 Summary of Test Results.....</b>	<b>5</b>
2.1 Measurement Uncertainty.....	5
2.2 Modification Record .....	5
<b>3 General Information .....</b>	<b>6</b>
3.1 General Description of EUT .....	6
3.2 Description of Test Modes.....	7
3.2.1 Test Mode Applicability and Tested Channel Detail.....	8
3.3 Description of Support Units .....	10
3.3.1 Configuration of System under Test .....	10
3.4 General Description of Applied Standards.....	10
<b>4 Test Types and Results .....</b>	<b>11</b>
4.1 Radiated Emission and Bandedge Measurement .....	11
4.1.1 Limits of Radiated Emission and Bandedge Measurement .....	11
4.1.2 Limits of Unwanted Emission Out of the Restricted Bands.....	12
4.1.3 Test Instruments .....	13
4.1.4 Test Procedures.....	14
4.1.5 Deviation from Test Standard .....	14
4.1.6 Test Set Up .....	15
4.1.7 EUT Operating Conditions.....	16
4.1.8 Test Results .....	17
4.2 Conducted Emission Measurement.....	51
4.2.1 Limits of Conducted Emission Measurement .....	51
4.2.2 Test Instruments .....	51
4.2.3 Test Procedures.....	52
4.2.4 Deviation from Test Standard .....	52
4.2.5 Test Setup.....	52
4.2.6 EUT Operating Conditions.....	52
4.2.7 Test Results .....	53
<b>5 Pictures of Test Arrangements.....</b>	<b>55</b>
<b>Appendix – Information on the Testing Laboratories .....</b>	<b>56</b>

### Release Control Record

Issue No.	Description	Date Issued
RF171212C20A	Original Release	Mar. 05, 2018

## 1 Certificate of Conformity

**Product:** LTE Module

**Brand:** Quectel

**Test Model:** SC20-A

**Sample Status:** Identical Prototype

**Applicant:** Quectel Wireless Solutions Co., Ltd.

**Test Date:** Jan. 19, 2018 ~ Feb. 05, 2018

**Standards:** 47 CFR FCC Part 15, Subpart E (Section 15.407)  
ANSI C63.10:2013

The above equipment has been tested by **Bureau Veritas Consumer Products Services (H.K.) Ltd., Taoyuan Branch**, and found compliance with the requirement of the above standards. The test record, data evaluation & Equipment Under Test (EUT) configurations represented herein are true and accurate accounts of the measurements of the sample's RF characteristics under the conditions specified in this report.

**Prepared by :** , **Date:** Mar. 05, 2018  
Vera Huang / Specialist

**Approved by :** , **Date:** Mar. 05, 2018  
Dylan Chiou / Project Engineer

## 2 Summary of Test Results

47 CFR FCC Part 15, Subpart E (Section 15.407)			
FCC Clause	Test Item	Result	Remarks
15.407(b)(6)	AC Power Conducted Emissions	Pass	Meet the requirement of limit. Minimum passing margin is -6.34 dB at 0.20201 MHz.
15.407(b) (1/2/3/4(i/ii)/6)	Radiated Emissions & Band Edge Measurement	Pass	Meet the requirement of limit. Minimum passing margin is -1.14 dB at 5470 MHz.
15.407(a)(1/2/3)	Max Average Transmit Power	N/A	Refer to Note
---	Occupied Bandwidth Measurement	N/A	Refer to Note
15.407(a)(1/2/3)	Peak Power Spectral Density	N/A	Refer to Note
15.407(e)	6 dB Bandwidth	N/A	Refer to Note
15.407(g)	Frequency Stability	N/A	Refer to Note
15.203	Antenna Requirement	N/A	Refer to Note

Note:

Only test item for Conducted Emissions and Radiated Emissions were performed for this report. For other test data, please refer to Sporton report No.: FR741007D and FR741007E for module (Brand: Quectel, Model: SC20-A).

### 2.1 Measurement Uncertainty

Where relevant, the following measurement uncertainty levels have been estimated for tests performed on the EUT as specified in CISPR 16-4-2:

Measurement	Frequency	Expanded Uncertainty (k=2) (±)
Conducted Emissions at mains ports	150 kHz ~ 30 MHz	2.44 dB
Radiated Emissions up to 1 GHz	30 MHz ~ 200 MHz	2.93 dB
	200 MHz ~ 1000 MHz	2.95 dB
Radiated Emissions above 1 GHz	1 GHz ~ 18 GHz	2.26 dB
	18 GHz ~ 40 GHz	1.94 dB

### 2.2 Modification Record

There were no modifications required for compliance.

### 3 General Information

#### 3.1 General Description of EUT

<b>Product</b>	LTE Module
<b>Brand</b>	Quectel
<b>Test Model</b>	SC20-A
<b>Status of EUT</b>	Identical Prototype
<b>Power Supply Rating</b>	5.0 Vdc (adapter) 7.26 Vdc (Li-ion battery)
<b>Modulation Type</b>	64QAM, 16QAM, QPSK, BPSK
<b>Modulation Technology</b>	OFDM
<b>Transfer Rate</b>	802.11a: 54.0/ 48.0/ 36.0/ 24.0/ 18.0/ 12.0/ 9.0/ 6.0 Mbps 802.11n: up to MCS7
<b>Operating Frequency</b>	5180 ~ 5240 MHz, 5260 ~ 5320 MHz, 5500 ~ 5700 MHz
<b>Number of Channel</b>	5180 ~ 5240 MHz: 4 for 802.11a, 802.11n (HT20) 2 for 802.11n (HT40) 5260 ~ 5320 MHz: 4 for 802.11a, 802.11n (HT20) 2 for 802.11n (HT40) 5500 ~ 5700 MHz: 11 for 802.11a, 802.11n (HT20) 5 for 802.11n (HT40) 5745 ~ 5825 MHz: 5 for 802.11a, 802.11n (HT20) 2 for 802.11n (HT40)
<b>Antenna Type</b>	PIFA antenna with -2.24 dBi gain (5180 ~ 5240 MHz) PIFA antenna with -2.5 dBi gain (5260 ~ 5320 MHz) PIFA antenna with -2.97 dBi gain (5500 ~ 5700 MHz) PIFA antenna with -2.86 dBi gain (5745 ~ 5700825 MHz)
<b>Antenna Connector</b>	N/A
<b>Accessory Device</b>	Refer to Note as below
<b>Data Cable Supplied</b>	Refer to Note as below

**Note:**

1. The EUT was installed in POS Terminal (Brand: CASTLES TECHNOLOGY, Model: SATURN1000).
2. The EUT provides one completed transmitter and one receiver.

Modulation Mode	Tx Function
802.11a	1TX
802.11n (HT20)	1TX
802.11n (HT40)	1TX

\* The modulation and bandwidth are similar for 802.11n mode for HT20 / HT40, therefore investigated worst case to representative mode in test report. (Final test mode refer section 3.2.1)

3. The EUT contains following accessory devices.

Product	Brand	Model	Description
Battery	CHENG UEI PRECISION INDUSTRY CO., LTD.	S1-26H	7.26 Vdc, 2600 mAh
USB Cable	TAYU	2000007X	1m shielded cable w/o core

4. The above EUT information is declared by manufacturer and for more detailed features description, please refer to the manufacturer's specifications or user's manual.

### 3.2 Description of Test Modes

#### For 5180 ~ 5240 MHz

4 channels are provided for 802.11a, 802.11n (HT20):

Channel	Frequency (MHz)	Channel	Frequency (MHz)
36	5180	44	5220
40	5200	48	5240

2 channels are provided for 802.11n (HT40):

Channel	Frequency (MHz)	Channel	Frequency (MHz)
38	5190	46	5230

#### For 5260 ~ 5320 MHz

4 channels are provided for 802.11a, 802.11n (HT20):

Channel	Frequency (MHz)	Channel	Frequency (MHz)
52	5260	60	5300
56	5280	64	5320

2 channels are provided for 802.11n (HT40):

Channel	Frequency (MHz)	Channel	Frequency (MHz)
54	5270	62	5310

#### For 5500 ~ 5700 MHz

11 channels are provided for 802.11a, 802.11n (HT20):

Channel	Frequency (MHz)	Channel	Frequency (MHz)
100	5500	124	5620
104	5520	128	5640
108	5540	132	5660
112	5560	136	5680
116	5580	140	5700
120	5600		

5 channels are provided for 802.11n (HT40):

Channel	Frequency (MHz)	Channel	Frequency (MHz)
102	5510	126	5630
110	5550	134	5670
118	5590		

**For 5745 ~ 5825 MHz:**

5 channels are provided for 802.11a, 802.11n (HT20):

Channel	Frequency (MHz)	Channel	Frequency (MHz)
149	5745	161	5805
153	5765	165	5825
157	5785		

2 channels are provided for 802.11n (HT40):

Channel	Frequency (MHz)	Channel	Frequency (MHz)
151	5755	159	5795

**3.2.1 Test Mode Applicability and Tested Channel Detail**

EUT Configure Mode	Applicable To				Description
	RE≥1G	RE<1G	PLC	APCM	
-	√	√	√	-	-

Where **RE≥1G**: Radiated Emission above 1 GHz      **RE<1G**: Radiated Emission below 1 GHz  
**PLC**: Power Line Conducted Emission      **APCM**: Antenna Port Conducted Measurement

**Note:**

- The EUT had been pre-tested on the positioned of each 3 axis. The worst case was found when positioned on **Y-plane**.

**Radiated Emission Test (Above 1 GHz):**

- Pre-Scan has been conducted to determine the worst-case mode from all possible combinations between available modulations, data rates and antenna ports (if EUT with antenna diversity architecture).
- Following channel(s) was (were) selected for the final test as listed below.

EUT Configure Mode	Frequency Band (MHz)	Mode	Available Channel	Tested Channel	Modulation Technology	Modulation Type	Data Rate (Mbps)	
-	5180-5240	802.11a	36 to 48	36, 44, 48	OFDM	BPSK	6.0	
-		802.11n (HT20)	36 to 48	36, 44, 48	OFDM	BPSK	MCS0	
-		802.11n (HT40)	38 to 46	38, 46	38, 46	OFDM	BPSK	MCS0
-	5260-5320	802.11a	52 to 64	52, 60, 64	OFDM	BPSK	6.0	
-		802.11n (HT20)	52 to 64	52, 60, 64	OFDM	BPSK	MCS0	
-		802.11n (HT40)	54 to 62	54, 62	54, 62	OFDM	BPSK	MCS0
-	5500-5700	802.11a	100 to 140	100, 116, 140	OFDM	BPSK	6.0	
-		802.11n (HT20)	100 to 140	100, 116, 140	OFDM	BPSK	MCS0	
-		802.11n (HT40)	102 to 134	102, 110, 134	102, 110, 134	OFDM	BPSK	MCS0
-	5745-5825	802.11a	149 to 165	149, 157, 165	OFDM	BPSK	6.0	
-		802.11n (HT20)	149 to 165	149, 157, 165	149, 157, 165	OFDM	BPSK	MCS0
-		802.11n (HT40)	151 to 159	151, 159	151, 159	OFDM	BPSK	MCS0



**Radiated Emission Test (Below 1 GHz):**

Pre-Scan has been conducted to determine the worst-case mode from all possible combinations between available modulations, data rates and antenna ports (if EUT with antenna diversity architecture).

Following channel(s) was (were) selected for the final test as listed below.

EUT Configure Mode	Frequency Band (MHz)	Mode	Available Channel	Tested Channel	Modulation Technology	Modulation Type	Data Rate (Mbps)
-	5500-5700	802.11n (HT40)	102 to 134	102	OFDM	BPSK	MCS0

**Power Line Conducted Emission Test:**

Pre-Scan has been conducted to determine the worst-case mode from all possible combinations between available modulations, data rates and antenna ports (if EUT with antenna diversity architecture).

Following channel(s) was (were) selected for the final test as listed below.

EUT Configure Mode	Frequency Band (MHz)	Mode	Available Channel	Tested Channel	Modulation Technology	Modulation Type	Data Rate (Mbps)
-	5500-5700	802.11n (HT40)	102 to 134	102	OFDM	BPSK	MCS0

**Test Condition:**

Applicable To	Environmental Conditions	Input Power	Tested by
RE $\geq$ 1G	25 deg. C, 65 % RH	120 Vac, 60 Hz	Jisyong Wang
RE<1G	25 deg. C, 65 % RH	120 Vac, 60 Hz	Jisyong Wang
PLC	25 deg. C, 65 % RH	120 Vac, 60 Hz	Getaz Yang

### 3.3 Description of Support Units

The EUT has been tested as an independent unit together with other necessary accessories or support units. The following support units or accessories were used to form a representative test configuration during the tests.

No.	Product	Brand	Model No.	Serial No.	FCC ID
1.	Adapter	FSP	FSP010-FPDN	N/A	N/A

No.	Signal Cable Description Of The Above Support Units
1.	N/A

Note:

1. All power cords of the above support units are non-shielded (1.8m).
2. Item 1 was provided by client.

#### 3.3.1 Configuration of System under Test

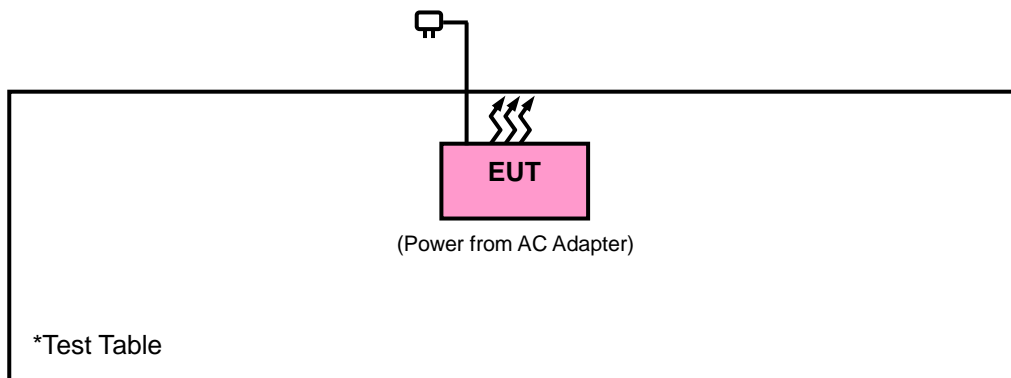

### 3.4 General Description of Applied Standards

The EUT is a RF Product. According to the specifications of the manufacturer, it must comply with the requirements of the following standards:

#### FCC Part 15, Subpart E (15.407)

#### 789033 D02 General UNII Test Procedures New Rules v02r01

ANSI C63.10-2013

All test items have been performed and recorded as per the above standards.

**Note:** The EUT has been verified to comply with the requirements of FCC Part 15, Subpart B, Class B (DoC). The test report has been issued separately.

## 4 Test Types and Results

### 4.1 Radiated Emission and Bandedge Measurement

#### 4.1.1 Limits of Radiated Emission and Bandedge Measurement

Radiated emissions which fall in the restricted bands must comply with the radiated emission limits specified as below table. Other emissions shall be at least 20 dB below the highest level of the desired power:

Frequencies (MHz)	Field Strength (microvolts/meter)	Measurement Distance (meters)
0.009 ~ 0.490	2400/F (kHz)	300
0.490 ~ 1.705	24000/F (kHz)	30
1.705 ~ 30.0	30	30
30 ~ 88	100	3
88 ~ 216	150	3
216 ~ 960	200	3
Above 960	500	3

**Note:**

1. The lower limit shall apply at the transition frequencies.
2. Emission level (dBuV/m) = 20 log Emission level (uV/m).
3. For frequencies above 1000 MHz, the field strength limits are based on average detector, however, the peak field strength of any emission shall not exceed the maximum permitted average limits, specified above by more than 20 dB under any condition of modulation.

#### 4.1.2 Limits of Unwanted Emission Out of the Restricted Bands

Applicable To		Limit	
789033 D02 General UNII Test Procedures New Rules v02r01		Field Strength at 3 m	
		PK: 74 (dBµV/m)	AV: 54 (dBµV/m)
Frequency Band	Applicable To	EIRP Limit	Equivalent Field Strength at 3 m
5150~5250 MHz	15.407(b)(1)	PK: -27 (dBm/MHz)	PK: 68.2 (dBµV/m)
5250~5350 MHz	15.407(b)(2)		
5470~5725 MHz	15.407(b)(3)		
5725~5850 MHz	15.407(b)(4)(i)	PK:-27 (dBm/MHz) <sup>*1</sup> PK:10 (dBm/MHz) <sup>*2</sup> PK:15.6 (dBm/MHz) <sup>*3</sup> PK:27 (dBm/MHz) <sup>*4</sup>	PK: 68.2 (dBµV/m) <sup>*1</sup> PK:105.2 (dBµV/m) <sup>*2</sup> PK: 110.8 (dBµV/m) <sup>*3</sup> PK:122.2 (dBµV/m) <sup>*4</sup>
	15.407(b)(4)(ii)	Emission limits in section 15.247(d)	
<sup>*1</sup> beyond 75 MHz or more above of the band edge. <sup>*2</sup> below the band edge increasing linearly to 10 dBm/MHz at 25 MHz above. <sup>*3</sup> below the band edge increasing linearly to a level of 15.6 dBm/MHz at 5 MHz above. <sup>*4</sup> from 5 MHz above or below the band edge increasing linearly to a level of 27 dBm/MHz at the band edge.			

**Note:**

The following formula is used to convert the equipment isotropic radiated power (eirp) to field strength:

$$E = \frac{1000000\sqrt{30P}}{3} \mu\text{V/m, where P is the eirp (Watts).}$$

## 4.1.3 Test Instruments

Description & Manufacturer	Model No.	Serial No.	Date of Calibration	Due Date of Calibration
Test Receiver Agilent	N9038A	MY51210203	Feb. 17, 2017	Feb. 16, 2018
Spectrum Analyzer Agilent	N9010A	MY52220314	Nov. 24, 2017	Nov. 23, 2018
Spectrum Analyzer ROHDE & SCHWARZ	FSU43	100115	Nov. 23, 2017	Nov. 22, 2018
Double Ridge Guide Horn Antenna EMCO	3115	5619	Nov. 30, 2017	Nov. 29, 2018
BILOG Antenna SCHWARZBECK	VULB 9168	9168-153	Dec. 06, 2017	Dec. 05, 2018
RF signal cable ETS-LINDGREN	5D-FB	Cable-CH1-01(R FC-SMS-100-SM S-120+RFC-SMS -100-SMS-400)	Jun. 23, 2017	Jun. 22, 2018
Loop Antenna	EM-6879	269	Aug. 11, 2017	Aug. 10, 2018
Preamplifier EMCI	EMC001340	980201	Nov. 01, 2017	Oct. 30, 2018
Preamplifier EMCI	EMC 012645	980115	Oct. 20, 2017	Oct. 19, 2018
Preamplifier EMCI	EMC 184045	980116	Oct. 20, 2017	Oct. 19, 2018
Preamplifier EMCI	EMC 330H	980112	Oct. 13, 2017	Oct. 12, 2018
Power Meter Anritsu	ML2495A	1012010	Aug. 15, 2017	Aug. 14, 2018
Power Sensor Anritsu	MA2411B	1315050	Aug. 15, 2017	Aug. 14, 2018
RF Coaxial Cable HUBER+SUHNNER	EMC104-SM-SM-8 000&3000	140811+170717	Oct. 20, 2017	Oct. 19, 2018
RF Coaxial Cable HUBER+SUHNNER	SUCOFLEX 104	EMC104-SM-SM- 1000(140807)	Oct. 20, 2017	Oct. 19, 2018
RF Coaxial Cable Worken	8D-FB	Cable-Ch10-01	Oct. 20, 2017	Oct. 19, 2018
Software BV ADT	E3 6.120103	NA	NA	NA
Antenna Tower MF	MFA-440H	NA	NA	NA
Turn Table MF	MFT-201SS	NA	NA	NA
Antenna Tower & Turn Table Controller MF	MF-7802	NA	NA	NA
Temperature & Humidity Chamber	GTH-120-40-CP-A R	MAA1306-019	Sep. 08, 2017	Sep. 07, 2018
DC Power Supply Topward	33010D	807748	Oct. 25, 2016	Oct. 24, 2018
Digital Multimeter Fluke	87-III	70360742	Jun. 30, 2017	Jun. 29, 2018

- Note:
1. The calibration interval of the above test instruments is 12 months and the calibrations are traceable to NML/ROC and NIST/USA.
  2. The test was performed in HwaYa Chamber 10.
  3. The horn antenna and preamplifier (model: EMC 184045) are used only for the measurement of emission frequency above 1 GHz if tested.
  4. The IC Site Registration No. is IC7450F-10.

#### 4.1.4 Test Procedures

- a. The EUT was placed on the top of a rotating table 0.8 meters (for below 1 GHz) / 1.5 meters (for above 1 GHz) above the ground at 3 meter chamber room for test. The table was rotated 360 degrees to determine the position of the highest radiation.
- b. The EUT was set 3 meters away from the interference-receiving antenna, which was mounted on the top of a variable-height antenna tower.
- c. The height of antenna is varied from one meter to four meters above the ground to determine the maximum value of the field strength. Both horizontal and vertical polarizations of the antenna are set to make the measurement.
- d. For each suspected emission, the EUT was arranged to its worst case and then the antenna was tuned to heights from 1 meter to 4 meters and the rotatable table was turned from 0 degrees to 360 degrees to find the maximum reading.
- e. The test-receiver system was set to quasi-peak detect function and specified bandwidth with maximum hold mode when the test frequency is below 1 GHz.
- f. The test-receiver system was set to peak and average detected function and specified bandwidth with maximum hold mode when the test frequency is above 1 GHz. If the peak reading value also meets average limit, measurement with the average detector is unnecessary.

#### Note:

1. The resolution bandwidth and video bandwidth of test receiver/spectrum analyzer is 120 kHz & 360 kHz for Quasi-peak detection (QP) at frequency below 1 GHz.
2. The resolution bandwidth of test receiver/spectrum analyzer is 1 MHz and the video bandwidth is 3 MHz for Peak detection (PK) at frequency above 1 GHz.
3. The resolution bandwidth of test receiver/spectrum analyzer is 1 MHz and the video bandwidth is 1/T for Average (Duty cycle < 98 %) detection at frequency above 1 GHz.
4. The resolution bandwidth of test receiver/spectrum analyzer is 1 MHz and the video bandwidth is 10 Hz (Duty cycle  $\geq$  98 %) for Average detection (AV) at frequency above 1 GHz.
5. All modes of operation were investigated and the worst-case emissions are reported.

#### 4.1.5 Deviation from Test Standard

No deviation.

4.1.6 Test Set Up

<Radiated emission below 30 MHz>

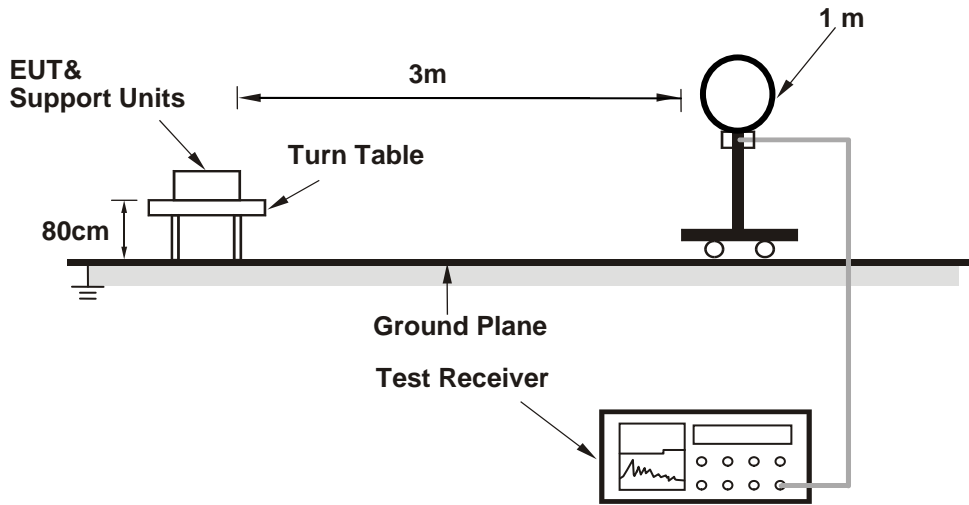

<Frequency Range below 1 GHz>

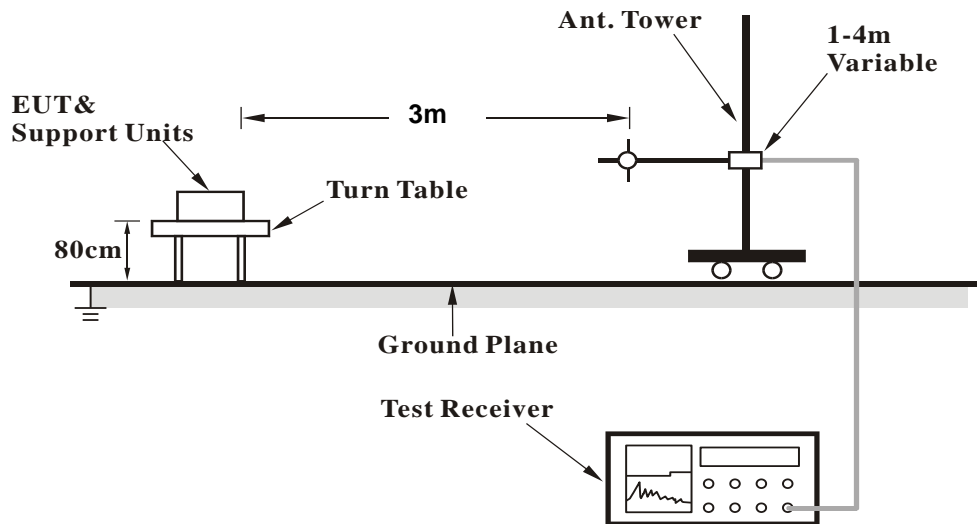

**<Frequency Range above 1 GHz>**

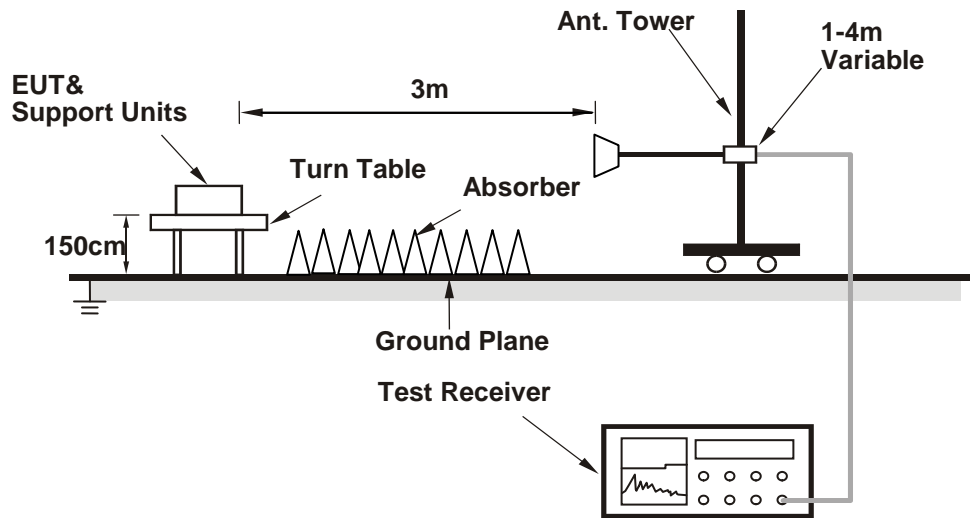

For the actual test configuration, please refer to the attached file (Test Setup Photo).

**4.1.7 EUT Operating Conditions**

- a. Placed the EUT on a testing table.
- b. Use the software to control the EUT under transmission condition continuously at specific channel frequency.



## 4.1.8 Test Results

## Above 1 GHz Data :

## 802.11a

EUT Test Condition		Measurement Detail	
Channel	Channel 36	Frequency Range	1 GHz ~ 40 GHz
Input Power	120 Vac, 60 Hz	Detector Function	Peak (PK) Average (AV)
Environmental Conditions	25 deg. C, 65 % RH	Tested By	Jisyong Wang

Antenna Polarity & Test Distance: Horizontal at 3 m										
Frequency (MHz)	Emission Level (dBuV/m)	Read Level (dBuV)	Limit (dBuV/m)	Margin (dB)	Antenna Factor (dB/m)	Cable Loss (dB)	Preamp Factor (dB)	Antenna Height (cm)	Table Angle (Degree)	Remark
5149.94	51.89	51.31	54	-2.11	31.56	6.34	37.32	145	35	Average
5149.94	71.67	71.09	74	-2.33	31.56	6.34	37.32	145	35	Peak
5180	96.03	95.41			31.59	6.37	37.34	145	35	Average
5180	105.99	105.37			31.59	6.37	37.34	145	35	Peak
*10360	56.12	58.88	68.2	-12.08	39.48	10.21	52.45	111	125	Peak
Antenna Polarity & Test Distance: Vertical at 3 m										
Frequency (MHz)	Emission Level (dBuV/m)	Read Level (dBuV)	Limit (dBuV/m)	Margin (dB)	Antenna Factor (dB/m)	Cable Loss (dB)	Preamp Factor (dB)	Antenna Height (cm)	Table Angle (Degree)	Remark
5149.76	47.14	46.56	54	-6.86	31.56	6.34	37.32	112	61	Average
5149.76	62.78	62.2	74	-11.22	31.56	6.34	37.32	112	61	Peak
5180	90.48	89.86			31.59	6.37	37.34	112	61	Average
5180	100.46	99.84			31.59	6.37	37.34	112	61	Peak
*10360	56.12	58.88	68.2	-12.08	39.48	10.21	52.45	111	125	Peak

## Remarks:

- Emission Level = Read Level + Antenna Factor + Cable Loss - Preamp Factor  
Margin value = Emission level – Limit value
- 5180 MHz: Fundamental Frequency
- \*: Out of Restricted Band

EUT Test Condition		Measurement Detail	
Channel	Channel 44	Frequency Range	1 GHz ~ 40 GHz
Input Power	120 Vac, 60 Hz	Detector Function	Peak (PK) Average (AV)
Environmental Conditions	25 deg. C, 65 % RH	Tested By	Jisyong Wang

Antenna Polarity & Test Distance: Horizontal at 3 m										
Frequency (MHz)	Emission Level (dBuV/m)	Read Level (dBuV)	Limit (dBuV/m)	Margin (dB)	Antenna Factor (dB/m)	Cable Loss (dB)	Preamp Factor (dB)	Antenna Height (cm)	Table Angle (Degree)	Remark
5138.6	39.02	38.44	54	-14.98	31.55	6.33	37.3	172	32	Average
5138.6	52.93	52.35	74	-21.07	31.55	6.33	37.3	172	32	Peak
5220	95.54	94.89			31.61	6.4	37.36	172	32	Average
5220	105.32	104.67			31.61	6.4	37.36	172	32	Peak
5364.52	38.76	37.75	54	-15.24	31.72	6.47	37.18	172	32	Average
5364.52	50.95	49.94	74	-23.05	31.72	6.47	37.18	172	32	Peak
5366.83	38.73	37.72	54	-15.27	31.72	6.47	37.18	172	32	Average
5366.83	51.38	50.37	74	-22.62	31.72	6.47	37.18	172	32	Peak
*10440	53.12	55.88	68.2	-15.08	39.55	10.21	52.52	125	123	Peak

Antenna Polarity & Test Distance: Vertical at 3 m										
Frequency (MHz)	Emission Level (dBuV/m)	Read Level (dBuV)	Limit (dBuV/m)	Margin (dB)	Antenna Factor (dB/m)	Cable Loss (dB)	Preamp Factor (dB)	Antenna Height (cm)	Table Angle (Degree)	Remark
5139.5	38.53	37.94	54	-15.47	31.56	6.33	37.3	111	65	Average
5139.5	50.77	50.18	74	-23.23	31.56	6.33	37.3	111	65	Peak
5220	90.27	89.62			31.61	6.4	37.36	111	65	Average
5220	100.9	100.25			31.61	6.4	37.36	111	65	Peak
5418.86	38.71	37.66	54	-15.29	31.75	6.48	37.18	111	65	Average
5418.86	51.49	50.44	74	-22.51	31.75	6.48	37.18	111	65	Peak
*10440	52.16	54.92	68.2	-16.04	39.55	10.21	52.52	232	125	Peak

Remarks:

- Emission Level = Read Level + Antenna Factor + Cable Loss - Preamp Factor  
Margin value = Emission level – Limit value
- 5220 MHz: Fundamental Frequency
- \*: Out of Restricted Band

EUT Test Condition		Measurement Detail	
Channel	Channel 48	Frequency Range	1 GHz ~ 40 GHz
Input Power	120 Vac, 60 Hz	Detector Function	Peak (PK) Average (AV)
Environmental Conditions	25 deg. C, 65 % RH	Tested By	Jisyong Wang

Antenna Polarity & Test Distance: Horizontal at 3 m										
Frequency (MHz)	Emission Level (dBuV/m)	Read Level (dBuV)	Limit (dBuV/m)	Margin (dB)	Antenna Factor (dB/m)	Cable Loss (dB)	Preamp Factor (dB)	Antenna Height (cm)	Table Angle (Degree)	Remark
5068.94	37.48	36.97	54	-16.52	31.51	6.27	37.27	164	29	Average
5068.94	49.64	49.13	74	-24.36	31.51	6.27	37.27	164	29	Peak
5240	93.56	92.84			31.62	6.42	37.32	164	29	Average
5240	103.4	102.68			31.62	6.42	37.32	164	29	Peak
5380.25	37.86	36.84	54	-16.14	31.73	6.47	37.18	164	29	Average
5380.25	51	49.98	74	-23	31.73	6.47	37.18	164	29	Peak
*10480	53.62	56.46	68.2	-14.58	39.6	10.22	52.66	111	152	Peak

Antenna Polarity & Test Distance: Vertical at 3 m										
Frequency (MHz)	Emission Level (dBuV/m)	Read Level (dBuV)	Limit (dBuV/m)	Margin (dB)	Antenna Factor (dB/m)	Cable Loss (dB)	Preamp Factor (dB)	Antenna Height (cm)	Table Angle (Degree)	Remark
5132.12	36.39	35.82	54	-17.61	31.55	6.32	37.3	106	64	Average
5132.12	49.54	48.97	74	-24.46	31.55	6.32	37.3	106	64	Peak
5240	87.4	86.68			31.62	6.42	37.32	106	64	Average
5240	97.41	96.69			31.62	6.42	37.32	106	64	Peak
5358.25	37.74	36.75	54	-16.26	31.7	6.47	37.18	106	64	Average
5358.25	50.48	49.49	74	-23.52	31.7	6.47	37.18	106	64	Peak
*10480	53.53	56.37	68.2	-14.67	39.6	10.22	52.66	256	231	Peak

Remarks:

- Emission Level = Read Level + Antenna Factor + Cable Loss - Preamp Factor  
Margin value = Emission level – Limit value
- 5240 MHz: Fundamental Frequency
- \*: Out of Restricted Band

EUT Test Condition		Measurement Detail	
Channel	Channel 52	Frequency Range	1 GHz ~ 40 GHz
Input Power	120 Vac, 60 Hz	Detector Function	Peak (PK) Average (AV)
Environmental Conditions	25 deg. C, 65 % RH	Tested By	Jisyong Wang

Antenna Polarity & Test Distance: Horizontal at 3 m										
Frequency (MHz)	Emission Level (dBuV/m)	Read Level (dBuV)	Limit (dBuV/m)	Margin (dB)	Antenna Factor (dB/m)	Cable Loss (dB)	Preamp Factor (dB)	Antenna Height (cm)	Table Angle (Degree)	Remark
5127.26	38.38	37.81	54	-15.62	31.55	6.32	37.3	123	33	Average
5127.26	50.56	49.99	74	-23.44	31.55	6.32	37.3	123	33	Peak
5260	96.6	95.79			31.65	6.43	37.27	123	33	Average
5260	106.62	105.81			31.65	6.43	37.27	123	33	Peak
5392.35	38.64	37.62	54	-15.36	31.73	6.47	37.18	123	33	Average
5392.35	50.94	49.92	74	-23.06	31.73	6.47	37.18	123	33	Peak
*10520	52.63	55.43	68.2	-15.57	39.66	10.27	52.73	123	256	Peak
Antenna Polarity & Test Distance: Vertical at 3 m										
Frequency (MHz)	Emission Level (dBuV/m)	Read Level (dBuV)	Limit (dBuV/m)	Margin (dB)	Antenna Factor (dB/m)	Cable Loss (dB)	Preamp Factor (dB)	Antenna Height (cm)	Table Angle (Degree)	Remark
5024.84	38.34	37.87	54	-15.66	31.48	6.23	37.24	112	63	Average
5024.84	50.39	49.92	74	-23.61	31.48	6.23	37.24	112	63	Peak
5260	88.31	87.5			31.65	6.43	37.27	112	63	Average
5260	98.29	97.48			31.65	6.43	37.27	112	63	Peak
5391.8	38.61	37.59	54	-15.39	31.73	6.47	37.18	112	63	Average
5391.8	50.78	49.76	74	-23.22	31.73	6.47	37.18	112	63	Peak
*10520	51.92	54.72	68.2	-16.28	39.66	10.27	52.73	111	132	Peak

Remarks:

- Emission Level = Read Level + Antenna Factor + Cable Loss - Preamp Factor  
Margin value = Emission level – Limit value
- 5260 MHz: Fundamental Frequency
- \*: Out of Restricted Band

EUT Test Condition		Measurement Detail	
Channel	Channel 60	Frequency Range	1 GHz ~ 40 GHz
Input Power	120 Vac, 60 Hz	Detector Function	Peak (PK) Average (AV)
Environmental Conditions	25 deg. C, 65 % RH	Tested By	Jisyong Wang

Antenna Polarity & Test Distance: Horizontal at 3 m										
Frequency (MHz)	Emission Level (dBuV/m)	Read Level (dBuV)	Limit (dBuV/m)	Margin (dB)	Antenna Factor (dB/m)	Cable Loss (dB)	Preamp Factor (dB)	Antenna Height (cm)	Table Angle (Degree)	Remark
5046.44	38.67	38.18	54	-15.33	31.49	6.25	37.25	158	31	Average
5046.44	51.24	50.75	74	-22.76	31.49	6.25	37.25	158	31	Peak
5300	94.56	93.62			31.67	6.46	37.19	158	31	Average
5300	104.56	103.62			31.67	6.46	37.19	158	31	Peak
5351.87	42.86	41.87	54	-11.14	31.7	6.47	37.18	158	31	Average
5351.87	53.52	52.53	74	-20.48	31.7	6.47	37.18	158	31	Peak
10600	47.53	50.36	54	-6.47	39.85	10.43	53.11	111	123	Average
10600	57.52	60.35	74	-16.48	39.85	10.43	53.11	111	123	Peak
Antenna Polarity & Test Distance: Vertical at 3 m										
Frequency (MHz)	Emission Level (dBuV/m)	Read Level (dBuV)	Limit (dBuV/m)	Margin (dB)	Antenna Factor (dB/m)	Cable Loss (dB)	Preamp Factor (dB)	Antenna Height (cm)	Table Angle (Degree)	Remark
5135.9	38.64	38.06	54	-15.36	31.55	6.33	37.3	114	67	Average
5135.9	51.23	50.65	74	-22.77	31.55	6.33	37.3	114	67	Peak
5300	88.93	87.99			31.67	6.46	37.19	114	67	Average
5300	98.93	97.99			31.67	6.46	37.19	114	67	Peak
5351.54	40.34	39.35	54	-13.66	31.7	6.47	37.18	114	67	Average
5351.54	52.07	51.08	74	-21.93	31.7	6.47	37.18	114	67	Peak
10600	45.58	48.41	54	-8.42	39.85	10.43	53.11	222	256	Average
10600	55.32	58.15	74	-18.68	39.85	10.43	53.11	222	256	Peak

Remarks:

- Emission Level = Read Level + Antenna Factor + Cable Loss - Preamp Factor  
Margin value = Emission level – Limit value
- 5300 MHz: Fundamental Frequency

EUT Test Condition		Measurement Detail	
Channel	Channel 64	Frequency Range	1 GHz ~ 40 GHz
Input Power	120 Vac, 60 Hz	Detector Function	Peak (PK) Average (AV)
Environmental Conditions	25 deg. C, 65 % RH	Tested By	Jisyong Wang

Antenna Polarity & Test Distance: Horizontal at 3 m										
Frequency (MHz)	Emission Level (dBuV/m)	Read Level (dBuV)	Limit (dBuV/m)	Margin (dB)	Antenna Factor (dB/m)	Cable Loss (dB)	Preamp Factor (dB)	Antenna Height (cm)	Table Angle (Degree)	Remark
5320	93.98	93.03			31.68	6.46	37.19	139	36	Average
5320	103.99	103.04			31.68	6.46	37.19	139	36	Peak
5351.54	48.35	47.36	54	-5.65	31.7	6.47	37.18	139	36	Average
5351.54	65.91	64.92	74	-8.09	31.7	6.47	37.18	139	36	Peak
10640	47.37	50.15	54	-6.63	39.93	10.36	53.07	111	165	Average
10640	57.47	60.25	74	-16.53	39.93	10.36	53.07	111	165	Peak

Antenna Polarity & Test Distance: Vertical at 3 m										
Frequency (MHz)	Emission Level (dBuV/m)	Read Level (dBuV)	Limit (dBuV/m)	Margin (dB)	Antenna Factor (dB/m)	Cable Loss (dB)	Preamp Factor (dB)	Antenna Height (cm)	Table Angle (Degree)	Remark
5320	89.03	88.08			31.68	6.46	37.19	114	68	Average
5320	99.04	98.09			31.68	6.46	37.19	114	68	Peak
5350.88	44.65	43.66	54	-9.35	31.7	6.47	37.18	114	68	Average
5350.88	58.37	57.38	74	-15.63	31.7	6.47	37.18	114	68	Peak
10640	45.74	48.52	54	-8.26	39.93	10.36	53.07	125	222	Average
10640	55.94	58.72	74	-18.06	39.93	10.36	53.07	125	222	Peak

Remarks:

- Emission Level = Read Level + Antenna Factor + Cable Loss - Preamp Factor  
Margin value = Emission level – Limit value
- 5320 MHz: Fundamental Frequency

EUT Test Condition		Measurement Detail	
Channel	Channel 100	Frequency Range	1 GHz ~ 40 GHz
Input Power	120 Vac, 60 Hz	Detector Function	Peak (PK) Average (AV)
Environmental Conditions	25 deg. C, 65 % RH	Tested By	Jisyong Wang

Antenna Polarity & Test Distance: Horizontal at 3 m										
Frequency (MHz)	Emission Level (dBuV/m)	Read Level (dBuV)	Limit (dBuV/m)	Margin (dB)	Antenna Factor (dB/m)	Cable Loss (dB)	Preamp Factor (dB)	Antenna Height (cm)	Table Angle (Degree)	Remark
5458.8	44.05	42.85	54	-9.95	31.77	6.51	37.08	162	357	Average
5458.8	58.91	57.71	74	-15.09	31.77	6.51	37.08	162	357	Peak
*5470	66.74	65.51	68.2	-1.46	31.79	6.52	37.08	162	357	Peak
5500	94.77	93.45			31.81	6.54	37.03	162	357	Average
5500	104.78	103.46			31.81	6.54	37.03	162	357	Peak
*5725	51.46	49.95	68.2	-16.74	32.18	6.76	37.43	162	357	Peak
11000	49.33	51.23	54	-4.67	40.73	10.4	53.03	125	265	Average
11000	59.33	61.23	74	-14.67	40.73	10.4	53.03	125	265	Peak

Antenna Polarity & Test Distance: Vertical at 3 m										
Frequency (MHz)	Emission Level (dBuV/m)	Read Level (dBuV)	Limit (dBuV/m)	Margin (dB)	Antenna Factor (dB/m)	Cable Loss (dB)	Preamp Factor (dB)	Antenna Height (cm)	Table Angle (Degree)	Remark
5459.6	40.17	38.97	54	-13.83	31.77	6.51	37.08	109	67	Average
5459.6	53.74	52.54	74	-20.26	31.77	6.51	37.08	109	67	Peak
*5470	57.18	55.95	68.2	-11.02	31.79	6.52	37.08	109	67	Peak
5500	86.46	85.14			31.81	6.54	37.03	109	67	Average
5500	96.47	95.15			31.81	6.54	37.03	109	67	Peak
*5725	51.2	49.69	68.2	-17	32.18	6.76	37.43	109	67	Peak
11000	47.73	49.63	54	-6.27	40.73	10.4	53.03	125	213	Average
11000	57.79	59.69	74	-16.21	40.73	10.4	53.03	125	213	Peak

Remarks:

- Emission Level = Read Level + Antenna Factor + Cable Loss - Preamp Factor  
Margin value = Emission level – Limit value
- 5500 MHz: Fundamental Frequency
- \*: Out of Restricted Band

EUT Test Condition		Measurement Detail	
Channel	Channel 116	Frequency Range	1 GHz ~ 40 GHz
Input Power	120 Vac, 60 Hz	Detector Function	Peak (PK) Average (AV)
Environmental Conditions	25 deg. C, 65 % RH	Tested By	Jisyong Wang

Antenna Polarity & Test Distance: Horizontal at 3 m										
Frequency (MHz)	Emission Level (dBuV/m)	Read Level (dBuV)	Limit (dBuV/m)	Margin (dB)	Antenna Factor (dB/m)	Cable Loss (dB)	Preamp Factor (dB)	Antenna Height (cm)	Table Angle (Degree)	Remark
5401.68	39.37	38.34	54	-14.63	31.74	6.47	37.18	165	1	Average
5401.68	51.06	50.03	74	-22.94	31.74	6.47	37.18	165	1	Peak
*5470	50.45	49.23	68.2	-17.75	31.79	6.51	37.08	165	1	Peak
5580	98.73	97.32			31.92	6.65	37.16	165	1	Average
5580	108.73	107.32			31.92	6.65	37.16	165	1	Peak
*5725	51.97	50.46	68.2	-16.23	32.18	6.76	37.43	165	1	Peak
11160	48.54	50.24	54	-5.46	40.56	10.52	52.78	152	123	Average
11160	58.83	60.53	74	-15.17	40.56	10.52	52.78	152	123	Peak

Antenna Polarity & Test Distance: Vertical at 3 m										
Frequency (MHz)	Emission Level (dBuV/m)	Read Level (dBuV)	Limit (dBuV/m)	Margin (dB)	Antenna Factor (dB/m)	Cable Loss (dB)	Preamp Factor (dB)	Antenna Height (cm)	Table Angle (Degree)	Remark
5390.64	39.06	38.04	54	-14.94	31.73	6.47	37.18	122	71	Average
5390.64	50.93	49.91	74	-23.07	31.73	6.47	37.18	122	71	Peak
*5470	50.24	49.04	68.2	-17.96	31.77	6.51	37.08	122	71	Peak
5580	91.13	89.72			31.92	6.65	37.16	122	71	Average
5580	101.13	99.72			31.92	6.65	37.16	122	71	Peak
*5725	51.17	49.66	68.2	-17.03	32.18	6.76	37.43	122	71	Peak
11160	46.56	48.26	54	-7.44	40.56	10.52	52.78	256	231	Average
11160	56.31	58.01	74	-17.69	40.56	10.52	52.78	256	231	Peak

Remarks:

- Emission Level = Read Level + Antenna Factor + Cable Loss - Preamp Factor  
Margin value = Emission level – Limit value
- 5580 MHz: Fundamental Frequency
- \*: Out of Restricted Band



EUT Test Condition		Measurement Detail	
Channel	Channel 140	Frequency Range	1 GHz ~ 40 GHz
Input Power	120 Vac, 60 Hz	Detector Function	Peak (PK) Average (AV)
Environmental Conditions	25 deg. C, 65 % RH	Tested By	Jisyong Wang

Antenna Polarity & Test Distance: Horizontal at 3 m										
Frequency (MHz)	Emission Level (dBuV/m)	Read Level (dBuV)	Limit (dBuV/m)	Margin (dB)	Antenna Factor (dB/m)	Cable Loss (dB)	Preamp Factor (dB)	Antenna Height (cm)	Table Angle (Degree)	Remark
5393.52	38.99	37.97	54	-15.01	31.73	6.47	37.18	118	360	Average
5393.52	51.58	50.56	74	-22.42	31.73	6.47	37.18	118	360	Peak
*5470	50.02	48.79	68.2	-18.18	31.79	6.52	37.08	118	360	Peak
5700	91.08	52.23			32.12	6.73	0	118	360	Average
5700	101.09	62.24			32.12	6.73	0	118	360	Peak
*5725	67.05	65.54	68.2	-1.15	32.18	6.76	37.43	118	360	Peak
11400	48.22	50.12	54	-5.78	40.33	10.47	52.7	125	236	Average
11400	58.33	60.23	74	-15.67	40.33	10.47	52.7	125	236	Peak

Antenna Polarity & Test Distance: Vertical at 3 m										
Frequency (MHz)	Emission Level (dBuV/m)	Read Level (dBuV)	Limit (dBuV/m)	Margin (dB)	Antenna Factor (dB/m)	Cable Loss (dB)	Preamp Factor (dB)	Antenna Height (cm)	Table Angle (Degree)	Remark
5447.28	38.92	37.78	54	-15.08	31.77	6.5	37.13	190	49	Average
5447.28	51.51	50.37	74	-22.49	31.77	6.5	37.13	190	49	Peak
*5470	50.64	49.41	68.2	-17.56	31.79	6.52	37.08	190	49	Peak
5700	87.54	86.09			32.12	6.73	37.4	190	49	Average
5700	97.55	96.1			32.12	6.73	37.4	190	49	Peak
*5725	62.63	61.12	68.2	-5.57	32.18	6.76	37.43	190	49	Peak
11400	47.73	49.63	54	-6.27	40.33	10.47	52.7	111	256	Average
11400	57.73	59.63	74	-16.27	40.33	10.47	52.7	111	256	Peak

Remarks:

- Emission Level = Read Level + Antenna Factor + Cable Loss - Preamp Factor  
Margin value = Emission level – Limit value
- 5700 MHz: Fundamental Frequency
- \*: Out of Restricted Band

EUT Test Condition		Measurement Detail	
Channel	Channel 149	Frequency Range	1 GHz ~ 40 GHz
Input Power	120 Vac, 60 Hz	Detector Function	Peak (PK) Average (AV)
Environmental Conditions	25 deg. C, 65 % RH	Tested By	Jisyong Wang

### <Spurious Emission>

Antenna Polarity & Test Distance: Horizontal at 3 m										
Frequency (MHz)	Emission Level (dBuV/m)	Read Level (dBuV)	Limit (dBuV/m)	Margin (dB)	Antenna Factor (dB/m)	Cable Loss (dB)	Preamp Factor (dB)	Antenna Height (cm)	Table Angle (Degree)	Remark
5745	90.87	89.35			32.21	6.78	37.47	171	259	Average
5745	100.23	98.71			32.21	6.78	37.47	171	259	Peak
11490	48.3	50.17	54	-5.7	40.25	10.66	52.78	112	201	Average
11490	58.31	60.18	74	-15.69	40.25	10.66	52.78	112	201	Peak
Antenna Polarity & Test Distance: Vertical at 3 m										
Frequency (MHz)	Emission Level (dBuV/m)	Read Level (dBuV)	Limit (dBuV/m)	Margin (dB)	Antenna Factor (dB/m)	Cable Loss (dB)	Preamp Factor (dB)	Antenna Height (cm)	Table Angle (Degree)	Remark
5745	92.51	90.99			32.21	6.78	37.47	203	161	Average
5745	102.95	101.43			32.21	6.78	37.47	203	161	Peak
11490	47.92	49.79	54	-6.08	40.25	10.66	52.78	152	231	Average
11490	57.97	59.84	74	-16.03	40.25	10.66	52.78	152	231	Peak

### <Out of Band Emission (OOBE)>

Antenna Polarity & Test Distance: Horizontal at 3 m										
Frequency (MHz)	Emission Level (dBuV/m)	Read Level (dBuV)	Limit (dBuV/m)	Margin (dB)	Antenna Factor (dB/m)	Cable Loss (dB)	Preamp Factor (dB)	Antenna Height (cm)	Table Angle (Degree)	Remark
5636.45	51.62	50.16	68.2	-16.58	32.04	6.7	37.28	171	259	Peak
5656.4	51.92	50.49	72.95	-21.03	32.06	6.71	37.34	171	259	Peak
5915.75	52.01	50.16	75.02	-23.01	32.49	6.86	37.5	171	259	Peak
5926.2	52.08	50.2	68.2	-16.12	32.52	6.86	37.5	171	259	Peak
Antenna Polarity & Test Distance: Vertical at 3 m										
Frequency (MHz)	Emission Level (dBuV/m)	Read Level (dBuV)	Limit (dBuV/m)	Margin (dB)	Antenna Factor (dB/m)	Cable Loss (dB)	Preamp Factor (dB)	Antenna Height (cm)	Table Angle (Degree)	Remark
5635.025	51.48	50.02	68.2	-16.72	32.04	6.7	37.28	203	161	Peak
5653.55	50.9	49.41	70.84	-19.94	32.06	6.71	37.28	203	161	Peak
5918.125	51.87	50.02	73.27	-21.4	32.49	6.86	37.5	203	161	Peak
6012.175	52.37	50.31	68.2	-15.83	32.67	6.89	37.5	203	161	Peak

#### Remarks:

- Emission Level = Read Level + Antenna Factor + Cable Loss - Preamp Factor  
Margin value = Emission level – Limit value
- 5745 MHz: Fundamental Frequency
- \*: Out of Restricted Band

EUT Test Condition		Measurement Detail	
Channel	Channel 157	Frequency Range	1 GHz ~ 40 GHz
Input Power	120 Vac, 60 Hz	Detector Function	Peak (PK) Average (AV)
Environmental Conditions	25 deg. C, 65 % RH	Tested By	Jisyong Wang

### <Spurious Emission>

Antenna Polarity & Test Distance: Horizontal at 3 m										
Frequency (MHz)	Emission Level (dBuV/m)	Read Level (dBuV)	Limit (dBuV/m)	Margin (dB)	Antenna Factor (dB/m)	Cable Loss (dB)	Preamp Factor (dB)	Antenna Height (cm)	Table Angle (Degree)	Remark
5785	92.06	90.52			32.26	6.82	37.54	173	307	Average
5785	102.06	100.52			32.26	6.82	37.54	173	307	Peak
11570	47	49.12	54	-7	40.13	10.76	53.01	111	132	Average
11570	57.07	59.19	74	-16.93	40.13	10.76	53.01	111	132	Peak
Antenna Polarity & Test Distance: Vertical at 3 m										
Frequency (MHz)	Emission Level (dBuV/m)	Read Level (dBuV)	Limit (dBuV/m)	Margin (dB)	Antenna Factor (dB/m)	Cable Loss (dB)	Preamp Factor (dB)	Antenna Height (cm)	Table Angle (Degree)	Remark
5785	92.49	90.95			32.26	6.82	37.54	167	158	Average
5785	102.56	101.02			32.26	6.82	37.54	167	158	Peak
11570	47.28	49.4	54	-6.72	40.13	10.76	53.01	102	231	Average
11570	57.36	59.48	74	-16.64	40.13	10.76	53.01	102	231	Peak

### <Out of Band Emission (OOBE)>

Antenna Polarity & Test Distance: Horizontal at 3 m										
Frequency (MHz)	Emission Level (dBuV/m)	Read Level (dBuV)	Limit (dBuV/m)	Margin (dB)	Antenna Factor (dB/m)	Cable Loss (dB)	Preamp Factor (dB)	Antenna Height (cm)	Table Angle (Degree)	Remark
5566.625	50.99	49.56	68.2	-17.21	31.92	6.63	37.12	167	158	Peak
5654.975	51.42	49.99	71.9	-20.48	32.06	6.71	37.34	167	158	Peak
5919.55	50.95	49.1	72.22	-21.27	32.49	6.86	37.5	167	158	Peak
6002.2	52.73	50.72	68.2	-15.47	32.63	6.89	37.51	167	158	Peak
Antenna Polarity & Test Distance: Vertical at 3 m										
Frequency (MHz)	Emission Level (dBuV/m)	Read Level (dBuV)	Limit (dBuV/m)	Margin (dB)	Antenna Factor (dB/m)	Cable Loss (dB)	Preamp Factor (dB)	Antenna Height (cm)	Table Angle (Degree)	Remark
5585.15	51.02	49.57	68.2	-17.18	31.95	6.66	37.16	173	307	Peak
5657.35	51.53	50.1	73.66	-22.13	32.06	6.71	37.34	173	307	Peak
5922.4	51.8	49.92	70.12	-18.32	32.52	6.86	37.5	173	307	Peak
5930	51.99	50.11	68.2	-16.21	32.52	6.86	37.5	173	307	Peak

#### Remarks:

- Emission Level = Read Level + Antenna Factor + Cable Loss - Preamp Factor  
Margin value = Emission level – Limit value
- 5785 MHz: Fundamental Frequency
- \*: Out of Restricted Band

EUT Test Condition		Measurement Detail	
Channel	Channel 165	Frequency Range	1 GHz ~ 40 GHz
Input Power	120 Vac, 60 Hz	Detector Function	Peak (PK) Average (AV)
Environmental Conditions	25 deg. C, 65 % RH	Tested By	Jisyong Wang

### <Spurious Emission>

Antenna Polarity & Test Distance: Horizontal at 3 m										
Frequency (MHz)	Emission Level (dBuV/m)	Read Level (dBuV)	Limit (dBuV/m)	Margin (dB)	Antenna Factor (dB/m)	Cable Loss (dB)	Preamp Factor (dB)	Antenna Height (cm)	Table Angle (Degree)	Remark
5825	91.64	89.98			32.35	6.84	37.53	166	290	Average
5825	101.64	99.98			32.35	6.84	37.53	166	290	Peak
11650	46.09	48.4	54	-7.91	40.03	10.8	53.14	125	222	Average
11650	56.15	58.46	74	-17.85	40.03	10.8	53.14	125	222	Peak
Antenna Polarity & Test Distance: Vertical at 3 m										
Frequency (MHz)	Emission Level (dBuV/m)	Read Level (dBuV)	Limit (dBuV/m)	Margin (dB)	Antenna Factor (dB/m)	Cable Loss (dB)	Preamp Factor (dB)	Antenna Height (cm)	Table Angle (Degree)	Remark
5825	93.16	91.5			32.35	6.84	37.53	208	157	Average
5825	103.17	101.51			32.35	6.84	37.53	208	157	Peak
11650	46.59	48.9	54	-7.41	40.03	10.8	53.14	185	232	Average
11650	56.64	58.95	74	-17.36	40.03	10.8	53.14	185	232	Peak

### <Out of Band Emission (OOBE)>

Antenna Polarity & Test Distance: Horizontal at 3 m										
Frequency (MHz)	Emission Level (dBuV/m)	Read Level (dBuV)	Limit (dBuV/m)	Margin (dB)	Antenna Factor (dB/m)	Cable Loss (dB)	Preamp Factor (dB)	Antenna Height (cm)	Table Angle (Degree)	Remark
5635.975	51.32	49.86	68.2	-16.88	32.04	6.7	37.28	166	290	Peak
5654.025	51.19	49.76	71.19	-20	32.06	6.71	37.34	166	290	Peak
5918.125	51.34	49.49	73.27	-21.93	32.49	6.86	37.5	166	290	Peak
5952.8	52.52	50.6	68.2	-15.68	32.55	6.87	37.5	166	290	Peak
Antenna Polarity & Test Distance: Vertical at 3 m										
Frequency (MHz)	Emission Level (dBuV/m)	Read Level (dBuV)	Limit (dBuV/m)	Margin (dB)	Antenna Factor (dB/m)	Cable Loss (dB)	Preamp Factor (dB)	Antenna Height (cm)	Table Angle (Degree)	Remark
5580.875	51.36	49.95	68.2	-16.84	31.92	6.65	37.16	208	157	Peak
5651.175	50.91	49.42	69.07	-18.16	32.06	6.71	37.28	208	157	Peak
5920.975	51.36	49.51	71.17	-19.81	32.49	6.86	37.5	208	157	Peak
5995.55	52.22	50.21	68.2	-15.98	32.63	6.89	37.51	208	157	Peak

#### Remarks:

- Emission Level = Read Level + Antenna Factor + Cable Loss - Preamp Factor  
Margin value = Emission level – Limit value
- 5825 MHz: Fundamental Frequency
- \*: Out of Restricted Band

### 802.11n (HT20)

EUT Test Condition		Measurement Detail	
Channel	Channel 36	Frequency Range	1 GHz ~ 40 GHz
Input Power	120 Vac, 60 Hz	Detector Function	Peak (PK) Average (AV)
Environmental Conditions	25 deg. C, 65 % RH	Tested By	Jisyong Wang

#### Antenna Polarity & Test Distance: Horizontal at 3 m

Frequency (MHz)	Emission Level (dBuV/m)	Read Level (dBuV)	Limit (dBuV/m)	Margin (dB)	Antenna Factor (dB/m)	Cable Loss (dB)	Preamp Factor (dB)	Antenna Height (cm)	Table Angle (Degree)	Remark
5148.5	50.37	49.79	54	-3.63	31.56	6.34	37.32	182	32	Average
5148.5	66.95	66.37	74	-7.05	31.56	6.34	37.32	182	32	Peak
5180	94.58	93.96			31.59	6.37	37.34	182	32	Average
5180	104.59	103.97			31.59	6.37	37.34	182	32	Peak
*10360	57.52	60.28	68.2	-10.68	39.48	10.21	52.45	253	123	Peak

#### Antenna Polarity & Test Distance: Vertical at 3 m

Frequency (MHz)	Emission Level (dBuV/m)	Read Level (dBuV)	Limit (dBuV/m)	Margin (dB)	Antenna Factor (dB/m)	Cable Loss (dB)	Preamp Factor (dB)	Antenna Height (cm)	Table Angle (Degree)	Remark
5149.94	46.43	45.85	54	-7.57	31.56	6.34	37.32	106	68	Average
5149.94	62.65	62.07	74	-11.35	31.56	6.34	37.32	106	68	Peak
5180	88.66	88.04			31.59	6.37	37.34	106	68	Average
5180	98.68	98.06			31.59	6.37	37.34	106	68	Peak
*10360	56.25	59.01	68.2	-11.95	39.48	10.21	52.45	112	165	Peak

#### Remarks:

- Emission Level = Read Level + Antenna Factor + Cable Loss - Preamp Factor  
Margin value = Emission level – Limit value
- 5180 MHz: Fundamental Frequency
- \*: Out of Restricted Band

EUT Test Condition		Measurement Detail	
Channel	Channel 44	Frequency Range	1 GHz ~ 40 GHz
Input Power	120 Vac, 60 Hz	Detector Function	Peak (PK) Average (AV)
Environmental Conditions	25 deg. C, 65 % RH	Tested By	Jisyong Wang

Antenna Polarity & Test Distance: Horizontal at 3 m										
Frequency (MHz)	Emission Level (dBuV/m)	Read Level (dBuV)	Limit (dBuV/m)	Margin (dB)	Antenna Factor (dB/m)	Cable Loss (dB)	Preamp Factor (dB)	Antenna Height (cm)	Table Angle (Degree)	Remark
5055.08	38.85	38.34	54	-15.15	31.51	6.25	37.25	168	32	Average
5055.08	51.3	50.79	74	-22.7	31.51	6.25	37.25	168	32	Peak
5220	94.97	94.32			31.61	6.4	37.36	168	32	Average
5220	104.94	104.29			31.61	6.4	37.36	168	32	Peak
5401.26	38.71	37.68	54	-15.29	31.74	6.47	37.18	168	32	Average
5401.26	51.43	50.4	74	-22.57	31.74	6.47	37.18	168	32	Peak
*10440	56.23	58.99	68.2	-11.97	39.55	10.21	52.52	100	31	Peak

Antenna Polarity & Test Distance: Vertical at 3 m										
Frequency (MHz)	Emission Level (dBuV/m)	Read Level (dBuV)	Limit (dBuV/m)	Margin (dB)	Antenna Factor (dB/m)	Cable Loss (dB)	Preamp Factor (dB)	Antenna Height (cm)	Table Angle (Degree)	Remark
5023.76	38.36	37.89	54	-15.64	31.48	6.23	37.24	111	60	Average
5023.76	51.35	50.88	74	-22.65	31.48	6.23	37.24	111	60	Peak
5220	89	88.35			31.61	6.4	37.36	111	60	Average
5220	98.92	98.27			31.61	6.4	37.36	111	60	Peak
5396.75	38.7	37.67	54	-15.3	31.74	6.47	37.18	111	60	Average
5396.75	51.2	50.17	74	-22.8	31.74	6.47	37.18	111	60	Peak
*10440	54.81	57.57	68.2	-13.39	39.55	10.21	52.52	100	31	Peak

Remarks:

- Emission Level = Read Level + Antenna Factor + Cable Loss - Preamp Factor  
Margin value = Emission level – Limit value
- 5220 MHz: Fundamental Frequency
- \*: Out of Restricted Band

EUT Test Condition		Measurement Detail	
Channel	Channel 48	Frequency Range	1 GHz ~ 40 GHz
Input Power	120 Vac, 60 Hz	Detector Function	Peak (PK) Average (AV)
Environmental Conditions	25 deg. C, 65 % RH	Tested By	Jisyong Wang

Antenna Polarity & Test Distance: Horizontal at 3 m										
Frequency (MHz)	Emission Level (dBuV/m)	Read Level (dBuV)	Limit (dBuV/m)	Margin (dB)	Antenna Factor (dB/m)	Cable Loss (dB)	Preamp Factor (dB)	Antenna Height (cm)	Table Angle (Degree)	Remark
5071.1	38.43	37.92	54	-15.57	31.51	6.27	37.27	166	31	Average
5071.1	50.82	50.31	74	-23.18	31.51	6.27	37.27	166	31	Peak
5240	94.64	93.92			31.62	6.42	37.32	166	31	Average
5240	104.64	103.92			31.62	6.42	37.32	166	31	Peak
5404.12	38.66	37.63	54	-15.34	31.74	6.47	37.18	166	31	Average
5404.12	50.7	49.67	74	-23.3	31.74	6.47	37.18	166	31	Peak
*10480	56.8	59.64	68.2	-11.4	39.6	10.22	52.66	231	256	Peak
Antenna Polarity & Test Distance: Vertical at 3 m										
Frequency (MHz)	Emission Level (dBuV/m)	Read Level (dBuV)	Limit (dBuV/m)	Margin (dB)	Antenna Factor (dB/m)	Cable Loss (dB)	Preamp Factor (dB)	Antenna Height (cm)	Table Angle (Degree)	Remark
5135	38.46	37.89	54	-15.54	31.55	6.32	37.3	104	64	Average
5135	50.17	49.6	74	-23.83	31.55	6.32	37.3	104	64	Peak
5240	88.94	88.22			31.62	6.42	37.32	104	64	Average
5240	98.97	98.25			31.62	6.42	37.32	104	64	Peak
5436.79	38.65	37.52	54	-15.35	31.76	6.5	37.13	104	64	Average
5436.79	50.87	49.74	74	-23.13	31.76	6.5	37.13	104	64	Peak
*10480	55.41	58.25	68.2	-12.79	39.6	10.22	52.66	111	123	Peak

Remarks:

- Emission Level = Read Level + Antenna Factor + Cable Loss - Preamp Factor  
Margin value = Emission level – Limit value
- 5240 MHz: Fundamental Frequency
- \*: Out of Restricted Band

EUT Test Condition		Measurement Detail	
Channel	Channel 52	Frequency Range	1 GHz ~ 40 GHz
Input Power	120 Vac, 60 Hz	Detector Function	Peak (PK) Average (AV)
Environmental Conditions	25 deg. C, 65 % RH	Tested By	Jisyong Wang

Antenna Polarity & Test Distance: Horizontal at 3 m										
Frequency (MHz)	Emission Level (dBuV/m)	Read Level (dBuV)	Limit (dBuV/m)	Margin (dB)	Antenna Factor (dB/m)	Cable Loss (dB)	Preamp Factor (dB)	Antenna Height (cm)	Table Angle (Degree)	Remark
5136.62	38.57	37.99	54	-15.43	31.55	6.33	37.3	149	34	Average
5136.62	51.37	50.79	74	-22.63	31.55	6.33	37.3	149	34	Peak
5260	93.6	92.79			31.65	6.43	37.27	149	34	Average
5260	103.12	102.31			31.65	6.43	37.27	149	34	Peak
5442.62	38.89	37.76	54	-15.11	31.76	6.5	37.13	149	34	Average
5442.62	51.5	50.37	74	-22.5	31.76	6.5	37.13	149	34	Peak
*10520	56.83	59.63	68.2	-11.37	39.66	10.27	52.73	125	223	Peak

Antenna Polarity & Test Distance: Vertical at 3 m										
Frequency (MHz)	Emission Level (dBuV/m)	Read Level (dBuV)	Limit (dBuV/m)	Margin (dB)	Antenna Factor (dB/m)	Cable Loss (dB)	Preamp Factor (dB)	Antenna Height (cm)	Table Angle (Degree)	Remark
5013.5	38.5	38.04	54	-15.5	31.47	6.22	37.23	102	71	Average
5013.5	50.57	50.11	74	-23.43	31.47	6.22	37.23	102	71	Peak
5260	86.56	85.75			31.65	6.43	37.27	102	71	Average
5260	96.56	95.75			31.65	6.43	37.27	102	71	Peak
5376.62	38.82	37.81	54	-15.18	31.72	6.47	37.18	102	71	Average
5376.62	51.29	50.28	74	-22.71	31.72	6.47	37.18	102	71	Peak
*10520	55.19	57.99	68.2	-13.01	39.66	10.27	52.73	325	123	Peak

Remarks:

- Emission Level = Read Level + Antenna Factor + Cable Loss - Preamp Factor  
Margin value = Emission level – Limit value
- 5260 MHz: Fundamental Frequency
- \*: Out of Restricted Band



EUT Test Condition		Measurement Detail	
Channel	Channel 60	Frequency Range	1 GHz ~ 40 GHz
Input Power	120 Vac, 60 Hz	Detector Function	Peak (PK) Average (AV)
Environmental Conditions	25 deg. C, 65 % RH	Tested By	Jisyong Wang

Antenna Polarity & Test Distance: Horizontal at 3 m										
Frequency (MHz)	Emission Level (dBuV/m)	Read Level (dBuV)	Limit (dBuV/m)	Margin (dB)	Antenna Factor (dB/m)	Cable Loss (dB)	Preamp Factor (dB)	Antenna Height (cm)	Table Angle (Degree)	Remark
5073.26	38.49	37.97	54	-15.51	31.52	6.27	37.27	144	34	Average
5073.26	50.66	50.14	74	-23.34	31.52	6.27	37.27	144	34	Peak
5300	93.65	92.71			31.67	6.46	37.19	144	34	Average
5300	103.51	102.57			31.67	6.46	37.19	144	34	Peak
5352.86	43.07	42.08	54	-10.93	31.7	6.47	37.18	144	34	Average
5352.86	54.43	53.44	74	-19.57	31.7	6.47	37.18	144	34	Peak
10600	46.82	49.65	54	-7.18	39.85	10.43	53.11	155	111	Average
10600	57.13	59.96	74	-16.87	39.85	10.43	53.11	155	111	Peak
Antenna Polarity & Test Distance: Vertical at 3 m										
Frequency (MHz)	Emission Level (dBuV/m)	Read Level (dBuV)	Limit (dBuV/m)	Margin (dB)	Antenna Factor (dB/m)	Cable Loss (dB)	Preamp Factor (dB)	Antenna Height (cm)	Table Angle (Degree)	Remark
5025.74	38.52	38.05	54	-15.48	31.48	6.23	37.24	116	68	Average
5025.74	50.99	50.52	74	-23.01	31.48	6.23	37.24	116	68	Peak
5300	87.77	86.83			31.67	6.46	37.19	116	68	Average
5300	97.78	96.84			31.67	6.46	37.19	116	68	Peak
5362.98	40.31	39.3	54	-13.69	31.72	6.47	37.18	116	68	Average
5362.98	51.11	50.1	74	-22.89	31.72	6.47	37.18	116	68	Peak
10600	44.8	47.63	54	-9.2	39.85	10.43	53.11	222	295	Average
10600	55.14	57.97	74	-18.86	39.85	10.43	53.11	222	295	Peak

Remarks:

- Emission Level = Read Level + Antenna Factor + Cable Loss - Preamp Factor  
Margin value = Emission level – Limit value
- 5300 MHz: Fundamental Frequency

EUT Test Condition		Measurement Detail	
Channel	Channel 64	Frequency Range	1 GHz ~ 40 GHz
Input Power	120 Vac, 60 Hz	Detector Function	Peak (PK) Average (AV)
Environmental Conditions	25 deg. C, 65 % RH	Tested By	Jisyong Wang

Antenna Polarity & Test Distance: Horizontal at 3 m										
Frequency (MHz)	Emission Level (dBuV/m)	Read Level (dBuV)	Limit (dBuV/m)	Margin (dB)	Antenna Factor (dB/m)	Cable Loss (dB)	Preamp Factor (dB)	Antenna Height (cm)	Table Angle (Degree)	Remark
5320	93.23	92.28			31.68	6.46	37.19	155	36	Average
5320	103.23	102.28			31.68	6.46	37.19	155	36	Peak
5350.44	46.73	45.74	54	-7.27	31.7	6.47	37.18	155	36	Average
5350.44	63.82	62.83	74	-10.18	31.7	6.47	37.18	155	36	Peak
10640	47.45	50.23	54	-6.55	39.93	10.36	53.07	125	265	Average
10640	57.45	60.23	74	-16.55	39.93	10.36	53.07	125	265	Peak

Antenna Polarity & Test Distance: Vertical at 3 m										
Frequency (MHz)	Emission Level (dBuV/m)	Read Level (dBuV)	Limit (dBuV/m)	Margin (dB)	Antenna Factor (dB/m)	Cable Loss (dB)	Preamp Factor (dB)	Antenna Height (cm)	Table Angle (Degree)	Remark
5320	87.97	87.02			31.68	6.46	37.19	115	66	Average
5320	97.97	97.02			31.68	6.46	37.19	115	66	Peak
5352.75	43.86	42.87	54	-10.14	31.7	6.47	37.18	115	66	Average
5352.75	57.17	56.18	74	-16.83	31.7	6.47	37.18	115	66	Peak
10640	45.85	48.63	54	-8.15	39.93	10.36	53.07	111	185	Average
10640	55.91	58.69	74	-18.09	39.93	10.36	53.07	111	185	Peak

Remarks:

- Emission Level = Read Level + Antenna Factor + Cable Loss - Preamp Factor  
Margin value = Emission level – Limit value
- 5320 MHz: Fundamental Frequency

EUT Test Condition		Measurement Detail	
Channel	Channel 100	Frequency Range	1 GHz ~ 40 GHz
Input Power	120 Vac, 60 Hz	Detector Function	Peak (PK) Average (AV)
Environmental Conditions	25 deg. C, 65 % RH	Tested By	Jisyong Wang

Antenna Polarity & Test Distance: Horizontal at 3 m										
Frequency (MHz)	Emission Level (dBuV/m)	Read Level (dBuV)	Limit (dBuV/m)	Margin (dB)	Antenna Factor (dB/m)	Cable Loss (dB)	Preamp Factor (dB)	Antenna Height (cm)	Table Angle (Degree)	Remark
5456.72	44.35	43.15	54	-9.65	31.77	6.51	37.08	167	357	Average
5456.72	59.42	58.22	74	-14.58	31.77	6.51	37.08	167	357	Peak
*5470	66.48	65.25	68.2	-1.72	31.79	6.52	37.08	167	357	Peak
5500	95.24	93.92			31.81	6.54	37.03	167	357	Average
5500	105.24	103.92			31.81	6.54	37.03	167	357	Peak
*5725	51.09	49.58	68.2	-17.11	32.18	6.76	37.43	167	357	Peak
11000	47.33	49.23	54	-6.67	40.73	10.4	53.03	152	236	Average
11000	57.73	59.63	74	-16.27	40.73	10.4	53.03	152	236	Peak

Antenna Polarity & Test Distance: Vertical at 3 m										
Frequency (MHz)	Emission Level (dBuV/m)	Read Level (dBuV)	Limit (dBuV/m)	Margin (dB)	Antenna Factor (dB/m)	Cable Loss (dB)	Preamp Factor (dB)	Antenna Height (cm)	Table Angle (Degree)	Remark
5459.9	41.87	40.67	54	-12.13	31.77	6.51	37.08	186	54	Average
5459.9	57.37	56.17	74	-16.63	31.77	6.51	37.08	186	54	Peak
*5470	60.69	59.46	68.2	-7.51	31.79	6.52	37.08	186	54	Peak
5500	90.69	89.37			31.81	6.54	37.03	186	54	Average
5500	100.69	99.37			31.81	6.54	37.03	186	54	Peak
*5725	50.89	49.38	68.2	-17.31	32.18	6.76	37.43	186	54	Peak
11000	46.73	48.63	54	-7.27	40.73	10.4	53.03	256	213	Average
11000	56.12	58.02	74	-17.88	40.73	10.4	53.03	256	213	Peak

Remarks:

- Emission Level = Read Level + Antenna Factor + Cable Loss - Preamp Factor  
Margin value = Emission level – Limit value
- 5500 MHz: Fundamental Frequency
- \*: Out of Restricted Band

EUT Test Condition		Measurement Detail	
Channel	Channel 116	Frequency Range	1 GHz ~ 40 GHz
Input Power	120 Vac, 60 Hz	Detector Function	Peak (PK) Average (AV)
Environmental Conditions	25 deg. C, 65 % RH	Tested By	Jisyong Wang

Antenna Polarity & Test Distance: Horizontal at 3 m										
Frequency (MHz)	Emission Level (dBuV/m)	Read Level (dBuV)	Limit (dBuV/m)	Margin (dB)	Antenna Factor (dB/m)	Cable Loss (dB)	Preamp Factor (dB)	Antenna Height (cm)	Table Angle (Degree)	Remark
5459.6	38.92	37.72	54	-9.95	31.77	6.51	37.08	191	19	Average
5459.6	50.93	49.73	74	-15.09	31.77	6.51	37.08	191	19	Peak
*5470	50.86	49.63	68.2	-17.34	31.79	6.52	37.08	191	19	Peak
5580	97.17	95.76			31.92	6.65	37.16	191	19	Average
5580	107.17	105.76			31.92	6.65	37.16	191	19	Peak
*5725	50.87	49.36	68.2	-17.33	32.18	6.76	37.43	191	19	Peak
11160	47.83	49.53	54	-4.67	40.56	10.52	52.78	125	236	Average
11160	57.94	59.64	74	-14.67	40.56	10.52	52.78	125	236	Peak

Antenna Polarity & Test Distance: Vertical at 3 m										
Frequency (MHz)	Emission Level (dBuV/m)	Read Level (dBuV)	Limit (dBuV/m)	Margin (dB)	Antenna Factor (dB/m)	Cable Loss (dB)	Preamp Factor (dB)	Antenna Height (cm)	Table Angle (Degree)	Remark
5452.08	38.81	37.61	54	-13.83	31.77	6.51	37.08	196	53	Average
5452.08	51.92	50.72	74	-20.26	31.77	6.51	37.08	196	53	Peak
*5470	50.32	49.09	68.2	-17.88	31.79	6.52	37.08	196	53	Peak
5580	93.73	92.32			31.92	6.65	37.16	196	53	Average
5580	103.74	102.33			31.92	6.65	37.16	196	53	Peak
*5725	50.81	49.3	68.2	-17.39	32.18	6.76	37.43	196	53	Peak
11160	45.94	47.64	54	-6.27	40.56	10.52	52.78	258	145	Average
11160	55.58	57.28	74	-16.21	40.56	10.52	52.78	258	145	Peak

Remarks:

- Emission Level = Read Level + Antenna Factor + Cable Loss - Preamp Factor  
Margin value = Emission level – Limit value
- 5580 MHz: Fundamental Frequency
- \*: Out of Restricted Band

EUT Test Condition		Measurement Detail	
Channel	Channel 140	Frequency Range	1 GHz ~ 40 GHz
Input Power	120 Vac, 60 Hz	Detector Function	Peak (PK) Average (AV)
Environmental Conditions	25 deg. C, 65 % RH	Tested By	Jisyong Wang

Antenna Polarity & Test Distance: Horizontal at 3 m										
Frequency (MHz)	Emission Level (dBuV/m)	Read Level (dBuV)	Limit (dBuV/m)	Margin (dB)	Antenna Factor (dB/m)	Cable Loss (dB)	Preamp Factor (dB)	Antenna Height (cm)	Table Angle (Degree)	Remark
5423.44	38.8	37.74	54	-9.95	31.75	6.49	37.18	162	41	Average
5423.44	52.03	50.97	74	-15.09	31.75	6.49	37.18	162	41	Peak
*5470	51.2	49.97	68.2	-17	31.79	6.52	37.08	162	41	Peak
5700	90.87	89.42			32.12	6.73	37.4	162	41	Average
5700	100.88	99.43			32.12	6.73	37.4	162	41	Peak
*5725	66.89	65.38	68.2	-1.31	32.18	6.76	37.43	162	41	Peak
11400	48.62	50.52	54	-4.67	40.33	10.47	52.7	256	123	Average
11400	58.62	60.52	74	-14.67	40.33	10.47	52.7	256	123	Peak

Antenna Polarity & Test Distance: Vertical at 3 m										
Frequency (MHz)	Emission Level (dBuV/m)	Read Level (dBuV)	Limit (dBuV/m)	Margin (dB)	Antenna Factor (dB/m)	Cable Loss (dB)	Preamp Factor (dB)	Antenna Height (cm)	Table Angle (Degree)	Remark
5446.96	38.87	37.73	54	-13.83	31.77	6.5	37.13	164	53	Average
5446.96	50.73	49.59	74	-20.26	31.77	6.5	37.13	164	53	Peak
*5470	50.9	49.68	68.2	-17.3	31.79	6.51	37.08	164	53	Peak
5700	88.87	87.42			32.12	6.73	37.4	164	53	Average
5700	98.88	97.43			32.12	6.73	37.4	164	53	Peak
*5725	66.31	64.8	68.2	-1.89	32.18	6.76	37.43	164	53	Peak
11400	46.62	48.52	54	-6.27	40.33	10.47	52.7	256	123	Average
11400	56.56	58.46	74	-16.21	40.33	10.47	52.7	256	123	Peak

Remarks:

- Emission Level = Read Level + Antenna Factor + Cable Loss - Preamp Factor  
Margin value = Emission level – Limit value
- 5700 MHz: Fundamental Frequency
- \*: Out of Restricted Band

EUT Test Condition		Measurement Detail	
Channel	Channel 149	Frequency Range	1 GHz ~ 40 GHz
Input Power	120 Vac, 60 Hz	Detector Function	Peak (PK) Average (AV)
Environmental Conditions	25 deg. C, 65 % RH	Tested By	Jisyong Wang

<Spurious Emission>

Antenna Polarity & Test Distance: Horizontal at 3 m										
Frequency (MHz)	Emission Level (dBuV/m)	Read Level (dBuV)	Limit (dBuV/m)	Margin (dB)	Antenna Factor (dB/m)	Cable Loss (dB)	Preamp Factor (dB)	Antenna Height (cm)	Table Angle (Degree)	Remark
5745	93.49	91.97			32.21	6.78	37.47	170	311	Average
5745	103.5	101.98			32.21	6.78	37.47	170	311	Peak
11490	47.44	49.31	54	-6.56	40.25	10.66	52.78	152	132	Average
11490	57.45	59.32	74	-16.55	40.25	10.66	52.78	152	132	Peak
Antenna Polarity & Test Distance: Vertical at 3 m										
Frequency (MHz)	Emission Level (dBuV/m)	Read Level (dBuV)	Limit (dBuV/m)	Margin (dB)	Antenna Factor (dB/m)	Cable Loss (dB)	Preamp Factor (dB)	Antenna Height (cm)	Table Angle (Degree)	Remark
5745	94.51	92.99			32.21	6.78	37.47	184	156	Average
5745	104.45	102.93			32.21	6.78	37.47	184	156	Peak
11490	47.25	49.12	54	-6.75	40.25	10.66	52.78	152	231	Average
11490	57.25	59.12	74	-16.75	40.25	10.66	52.78	152	231	Peak

<Out of Band Emission (OOBE)>

Antenna Polarity & Test Distance: Horizontal at 3 m										
Frequency (MHz)	Emission Level (dBuV/m)	Read Level (dBuV)	Limit (dBuV/m)	Margin (dB)	Antenna Factor (dB/m)	Cable Loss (dB)	Preamp Factor (dB)	Antenna Height (cm)	Table Angle (Degree)	Remark
5572.325	51.16	49.72	68.2	-17.04	31.92	6.64	37.12	170	311	Peak
5652.125	50.35	48.86	69.78	-19.43	32.06	6.71	37.28	170	311	Peak
5915.275	52.27	50.42	75.37	-23.1	32.49	6.86	37.5	170	311	Peak
5996.975	52.23	50.22	68.2	-15.97	32.63	6.89	37.51	170	311	Peak
Antenna Polarity & Test Distance: Vertical at 3 m										
Frequency (MHz)	Emission Level (dBuV/m)	Read Level (dBuV)	Limit (dBuV/m)	Margin (dB)	Antenna Factor (dB/m)	Cable Loss (dB)	Preamp Factor (dB)	Antenna Height (cm)	Table Angle (Degree)	Remark
5631.7	51.37	49.94	68.2	-16.83	32.01	6.7	37.28	184	156	Peak
5654.975	50.56	49.13	71.9	-21.34	32.06	6.71	37.34	184	156	Peak
5921.925	51.51	49.63	70.47	-18.96	32.52	6.86	37.5	184	156	Peak
5939.025	52.23	50.31	68.2	-15.97	32.55	6.87	37.5	184	156	Peak

Remarks:

- Emission Level = Read Level + Antenna Factor + Cable Loss - Preamp Factor  
Margin value = Emission level – Limit value
- 5745 MHz: Fundamental Frequency
- \*: Out of Restricted Band

EUT Test Condition		Measurement Detail	
Channel	Channel 157	Frequency Range	1 GHz ~ 40 GHz
Input Power	120 Vac, 60 Hz	Detector Function	Peak (PK) Average (AV)
Environmental Conditions	25 deg. C, 65 % RH	Tested By	Jisyong Wang

### <Spurious Emission>

Antenna Polarity & Test Distance: Horizontal at 3 m										
Frequency (MHz)	Emission Level (dBuV/m)	Read Level (dBuV)	Limit (dBuV/m)	Margin (dB)	Antenna Factor (dB/m)	Cable Loss (dB)	Preamp Factor (dB)	Antenna Height (cm)	Table Angle (Degree)	Remark
5785	91.47	89.93			32.26	6.82	37.54	172	290	Average
5785	101.44	99.9			32.26	6.82	37.54	172	290	Peak
11570	46.62	48.74	54	-7.38	40.13	10.76	53.01	202	231	Average
11570	56.63	58.75	74	-17.37	40.13	10.76	53.01	202	231	Peak
Antenna Polarity & Test Distance: Vertical at 3 m										
Frequency (MHz)	Emission Level (dBuV/m)	Read Level (dBuV)	Limit (dBuV/m)	Margin (dB)	Antenna Factor (dB/m)	Cable Loss (dB)	Preamp Factor (dB)	Antenna Height (cm)	Table Angle (Degree)	Remark
5785	92.77	91.23			32.26	6.82	37.54	189	158	Average
5785	102.77	101.23			32.26	6.82	37.54	189	158	Peak
11570	46.13	48.25	54	-7.87	40.13	10.76	53.01	152	231	Average
11570	56.5	58.62	74	-17.5	40.13	10.76	53.01	152	231	Peak

### <Out of Band Emission (OOBE)>

Antenna Polarity & Test Distance: Horizontal at 3 m										
Frequency (MHz)	Emission Level (dBuV/m)	Read Level (dBuV)	Limit (dBuV/m)	Margin (dB)	Antenna Factor (dB/m)	Cable Loss (dB)	Preamp Factor (dB)	Antenna Height (cm)	Table Angle (Degree)	Remark
5632.65	52.51	51.05	68.2	-15.69	32.04	6.7	37.28	172	290	Peak
5656.875	51.19	49.76	73.31	-22.12	32.06	6.71	37.34	172	290	Peak
5920.025	51.27	49.42	71.87	-20.6	32.49	6.86	37.5	172	290	Peak
5970.85	51.83	49.89	68.2	-16.37	32.57	6.88	37.51	172	290	Peak
Antenna Polarity & Test Distance: Vertical at 3 m										
Frequency (MHz)	Emission Level (dBuV/m)	Read Level (dBuV)	Limit (dBuV/m)	Margin (dB)	Antenna Factor (dB/m)	Cable Loss (dB)	Preamp Factor (dB)	Antenna Height (cm)	Table Angle (Degree)	Remark
5626	51.7	50.22	68.2	-16.5	32.01	6.69	37.22	189	158	Peak
5651.175	50.9	49.41	69.07	-18.17	32.06	6.71	37.28	189	158	Peak
5919.075	51.38	49.53	72.57	-21.19	32.49	6.86	37.5	189	158	Peak
5993.65	52.61	50.6	68.2	-15.59	32.63	6.89	37.51	189	158	Peak

#### Remarks:

- Emission Level = Read Level + Antenna Factor + Cable Loss - Preamp Factor  
Margin value = Emission level – Limit value
- 5785 MHz: Fundamental Frequency
- \*: Out of Restricted Band

EUT Test Condition		Measurement Detail	
Channel	Channel 165	Frequency Range	1 GHz ~ 40 GHz
Input Power	120 Vac, 60 Hz	Detector Function	Peak (PK) Average (AV)
Environmental Conditions	25 deg. C, 65 % RH	Tested By	Jisyong Wang

**<Spurious Emission>**

Antenna Polarity & Test Distance: Horizontal at 3 m										
Frequency (MHz)	Emission Level (dBuV/m)	Read Level (dBuV)	Limit (dBuV/m)	Margin (dB)	Antenna Factor (dB/m)	Cable Loss (dB)	Preamp Factor (dB)	Antenna Height (cm)	Table Angle (Degree)	Remark
5825	90.35	88.69			32.35	6.84	37.53	166	307	Average
5825	100.35	98.69			32.35	6.84	37.53	166	307	Peak
11650	45.94	48.25	54	-8.06	40.03	10.8	53.14	201	222	Average
11650	56.69	59	74	-17.31	40.03	10.8	53.14	201	222	Peak
Antenna Polarity & Test Distance: Vertical at 3 m										
Frequency (MHz)	Emission Level (dBuV/m)	Read Level (dBuV)	Limit (dBuV/m)	Margin (dB)	Antenna Factor (dB/m)	Cable Loss (dB)	Preamp Factor (dB)	Antenna Height (cm)	Table Angle (Degree)	Remark
5825	92.04	90.38			32.35	6.84	37.53	189	160	Average
5825	102.08	100.42			32.35	6.84	37.53	189	160	Peak
11650	46.27	48.58	54	-7.73	40.03	10.8	53.14	125	213	Average
11650	56.28	58.59	74	-17.72	40.03	10.8	53.14	125	213	Peak

**<Out of Band Emission (OOBE)>**

Antenna Polarity & Test Distance: Horizontal at 3 m										
Frequency (MHz)	Emission Level (dBuV/m)	Read Level (dBuV)	Limit (dBuV/m)	Margin (dB)	Antenna Factor (dB/m)	Cable Loss (dB)	Preamp Factor (dB)	Antenna Height (cm)	Table Angle (Degree)	Remark
5637.875	51.46	50	68.2	-16.74	32.04	6.7	37.28	189	160	Peak
5655.925	50.88	49.45	72.6	-21.72	32.06	6.71	37.34	189	160	Peak
5919.55	52.17	50.32	72.22	-20.05	32.49	6.86	37.5	189	160	Peak
5943.775	52.96	51.04	68.2	-15.24	32.55	6.87	37.5	189	160	Peak
Antenna Polarity & Test Distance: Vertical at 3 m										
Frequency (MHz)	Emission Level (dBuV/m)	Read Level (dBuV)	Limit (dBuV/m)	Margin (dB)	Antenna Factor (dB/m)	Cable Loss (dB)	Preamp Factor (dB)	Antenna Height (cm)	Table Angle (Degree)	Remark
5607	51.29	49.85	68.2	-16.91	31.98	6.68	37.22	166	307	Peak
5659.725	50.79	49.36	75.42	-24.63	32.06	6.71	37.34	166	307	Peak
5917.65	51.28	49.43	73.62	-22.34	32.49	6.86	37.5	166	307	Peak
5944.25	52.67	50.75	68.2	-15.53	32.55	6.87	37.5	166	307	Peak

Remarks:

- Emission Level = Read Level + Antenna Factor + Cable Loss - Preamp Factor  
Margin value = Emission level – Limit value
- 5825 MHz: Fundamental Frequency
- \*: Out of Restricted Band



802.11n (HT40)

EUT Test Condition		Measurement Detail	
Channel	Channel 38	Frequency Range	1 GHz ~ 40 GHz
Input Power	120 Vac, 60 Hz	Detector Function	Peak (PK) Average (AV)
Environmental Conditions	25 deg. C, 65 % RH	Tested By	Jisyong Wang

**Antenna Polarity & Test Distance: Horizontal at 3 m**

Frequency (MHz)	Emission Level (dBuV/m)	Read Level (dBuV)	Limit (dBuV/m)	Margin (dB)	Antenna Factor (dB/m)	Cable Loss (dB)	Preamp Factor (dB)	Antenna Height (cm)	Table Angle (Degree)	Remark
5149.76	52.7	52.12	54	-1.3	31.56	6.34	37.32	164	34	Average
5149.76	69.63	69.05	74	-4.37	31.56	6.34	37.32	164	34	Peak
5190	88.56	87.93			31.59	6.38	37.34	164	34	Average
5190	98.56	97.93			31.59	6.38	37.34	164	34	Peak
5446.25	38.94	37.8	54	-15.06	31.77	6.5	37.13	164	34	Average
5446.25	51.47	50.33	74	-22.53	31.77	6.5	37.13	164	34	Peak
*10380	55.63	58.37	68.2	-12.57	39.5	10.21	52.45	111	123	Peak

**Antenna Polarity & Test Distance: Vertical at 3 m**

Frequency (MHz)	Emission Level (dBuV/m)	Read Level (dBuV)	Limit (dBuV/m)	Margin (dB)	Antenna Factor (dB/m)	Cable Loss (dB)	Preamp Factor (dB)	Antenna Height (cm)	Table Angle (Degree)	Remark
5149.4	48	47.42	54	-6	31.56	6.34	37.32	112	67	Average
5149.4	62.07	61.49	74	-11.93	31.56	6.34	37.32	112	67	Peak
5190	82.6	81.97			31.59	6.38	37.34	112	67	Average
5190	92.61	91.98			31.59	6.38	37.34	112	67	Peak
5412.37	39.02	37.97	54	-14.98	31.75	6.48	37.18	112	67	Average
5412.37	51.31	50.26	74	-22.69	31.75	6.48	37.18	112	67	Peak
*10380	54.6	57.34	68.2	-13.6	39.5	10.21	52.45	232	125	Peak

Remarks:

- Emission Level = Read Level + Antenna Factor + Cable Loss - Preamp Factor  
Margin value = Emission level – Limit value
- 5190 MHz: Fundamental Frequency
- \*: Out of Restricted Band

EUT Test Condition		Measurement Detail	
Channel	Channel 46	Frequency Range	1 GHz ~ 40 GHz
Input Power	120 Vac, 60 Hz	Detector Function	Peak (PK) Average (AV)
Environmental Conditions	25 deg. C, 65 % RH	Tested By	Jisyong Wang

Antenna Polarity & Test Distance: Horizontal at 3 m										
Frequency (MHz)	Emission Level (dBuV/m)	Read Level (dBuV)	Limit (dBuV/m)	Margin (dB)	Antenna Factor (dB/m)	Cable Loss (dB)	Preamp Factor (dB)	Antenna Height (cm)	Table Angle (Degree)	Remark
5147.78	41.24	40.66	54	-12.76	31.56	6.34	37.32	163	34	Average
5147.78	54.51	53.93	74	-19.49	31.56	6.34	37.32	163	34	Peak
5230	89.91	89.2			31.62	6.41	37.32	163	34	Average
5230	99.92	99.21			31.62	6.41	37.32	163	34	Peak
5443.94	39.13	38	54	-14.87	31.76	6.5	37.13	163	34	Average
5443.94	51.61	50.48	74	-22.39	31.76	6.5	37.13	163	34	Peak
*10460	57.52	60.32	68.2	-10.68	39.57	10.22	52.59	123	256	Peak
Antenna Polarity & Test Distance: Vertical at 3 m										
Frequency (MHz)	Emission Level (dBuV/m)	Read Level (dBuV)	Limit (dBuV/m)	Margin (dB)	Antenna Factor (dB/m)	Cable Loss (dB)	Preamp Factor (dB)	Antenna Height (cm)	Table Angle (Degree)	Remark
5052.38	39.47	38.98	54	-14.53	31.49	6.25	37.25	104	70	Average
5052.38	51.02	50.53	74	-22.98	31.49	6.25	37.25	104	70	Peak
5230	84.3	83.59			31.62	6.41	37.32	104	70	Average
5230	94.3	93.59			31.62	6.41	37.32	104	70	Peak
5420.51	38.97	37.92	54	-15.03	31.75	6.48	37.18	104	70	Average
5420.51	51.56	50.51	74	-22.44	31.75	6.48	37.18	104	70	Peak
*10460	55.2	58	68.2	-13	39.57	10.22	52.59	222	265	Peak

Remarks:

- Emission Level = Read Level + Antenna Factor + Cable Loss - Preamp Factor  
Margin value = Emission level – Limit value
- 5230 MHz: Fundamental Frequency
- \*: Out of Restricted Band

EUT Test Condition		Measurement Detail	
Channel	Channel 54	Frequency Range	1 GHz ~ 40 GHz
Input Power	120 Vac, 60 Hz	Detector Function	Peak (PK) Average (AV)
Environmental Conditions	25 deg. C, 65 % RH	Tested By	Jisyong Wang

Antenna Polarity & Test Distance: Horizontal at 3 m										
Frequency (MHz)	Emission Level (dBuV/m)	Read Level (dBuV)	Limit (dBuV/m)	Margin (dB)	Antenna Factor (dB/m)	Cable Loss (dB)	Preamp Factor (dB)	Antenna Height (cm)	Table Angle (Degree)	Remark
5148.86	38.78	38.2	54	-15.22	31.56	6.34	37.32	163	31	Average
5148.86	51.06	50.48	74	-22.94	31.56	6.34	37.32	163	31	Peak
5270	90.85	90.03			31.65	6.44	37.27	163	31	Average
5270	100.85	100.03			31.65	6.44	37.27	163	31	Peak
5352.86	40.81	39.82	54	-13.19	31.7	6.47	37.18	163	31	Average
5352.86	52.37	51.38	74	-21.63	31.7	6.47	37.18	163	31	Peak
*10540	57.4	60.25	68.2	-10.8	39.7	10.31	52.86	152	126	Peak
Antenna Polarity & Test Distance: Vertical at 3 m										
Frequency (MHz)	Emission Level (dBuV/m)	Read Level (dBuV)	Limit (dBuV/m)	Margin (dB)	Antenna Factor (dB/m)	Cable Loss (dB)	Preamp Factor (dB)	Antenna Height (cm)	Table Angle (Degree)	Remark
5145.62	38.61	38.03	54	-15.39	31.56	6.34	37.32	104	66	Average
5145.62	52.16	51.58	74	-21.84	31.56	6.34	37.32	104	66	Peak
5266	84.84	84.02			31.65	6.44	37.27	104	66	Average
5266	94.84	94.02			31.65	6.44	37.27	104	66	Peak
5377.5	39.48	38.46	54	-14.52	31.73	6.47	37.18	104	66	Average
5377.5	51.86	50.84	74	-22.14	31.73	6.47	37.18	104	66	Peak
*10540	55.56	58.41	68.2	-12.64	39.7	10.31	52.86	185	145	Peak

Remarks:

- Emission Level = Read Level + Antenna Factor + Cable Loss - Preamp Factor  
Margin value = Emission level – Limit value
- 5270/5266 MHz: Fundamental Frequency
- \*: Out of Restricted Band

EUT Test Condition		Measurement Detail	
Channel	Channel 62	Frequency Range	1 GHz ~ 40 GHz
Input Power	120 Vac, 60 Hz	Detector Function	Peak (PK) Average (AV)
Environmental Conditions	25 deg. C, 65 % RH	Tested By	Jisyong Wang

Antenna Polarity & Test Distance: Horizontal at 3 m										
Frequency (MHz)	Emission Level (dBuV/m)	Read Level (dBuV)	Limit (dBuV/m)	Margin (dB)	Antenna Factor (dB/m)	Cable Loss (dB)	Preamp Factor (dB)	Antenna Height (cm)	Table Angle (Degree)	Remark
5094.5	38.74	38.2	54	-15.26	31.53	6.29	37.28	147	35	Average
5094.5	50.51	49.97	74	-23.49	31.53	6.29	37.28	147	35	Peak
5310	89.15	88.2			31.68	6.46	37.19	147	35	Average
5310	99.15	98.2			31.68	6.46	37.19	147	35	Peak
5350.22	52.7	51.71	54	-1.3	31.7	6.47	37.18	147	35	Average
5350.22	70.17	69.18	74	-3.83	31.7	6.47	37.18	147	35	Peak
10620	46.71	49.52	54	-7.29	39.89	10.39	53.09	125	236	Average
10620	56.82	59.63	74	-17.18	39.89	10.39	53.09	125	236	Peak
Antenna Polarity & Test Distance: Vertical at 3 m										
Frequency (MHz)	Emission Level (dBuV/m)	Read Level (dBuV)	Limit (dBuV/m)	Margin (dB)	Antenna Factor (dB/m)	Cable Loss (dB)	Preamp Factor (dB)	Antenna Height (cm)	Table Angle (Degree)	Remark
5148.68	38.7	38.12	54	-15.3	31.56	6.34	37.32	124	67	Average
5148.68	51.01	50.43	74	-22.99	31.56	6.34	37.32	124	67	Peak
5310	82.66	81.71			31.68	6.46	37.19	124	67	Average
5310	92.72	91.77			31.68	6.46	37.19	124	67	Peak
5350	47.72	46.73	54	-6.28	31.7	6.47	37.18	124	67	Average
5350	63.94	62.95	74	-10.06	31.7	6.47	37.18	124	67	Peak
10620	44.82	47.63	54	-9.18	39.89	10.39	53.09	285	265	Average
10620	54.25	57.06	74	-19.75	39.89	10.39	53.09	285	265	Peak

Remarks:

- Emission Level = Read Level + Antenna Factor + Cable Loss - Preamp Factor  
Margin value = Emission level – Limit value
- 5310 MHz: Fundamental Frequency

EUT Test Condition		Measurement Detail	
Channel	Channel 102	Frequency Range	1 GHz ~ 40 GHz
Input Power	120 Vac, 60 Hz	Detector Function	Peak (PK) Average (AV)
Environmental Conditions	25 deg. C, 65 % RH	Tested By	Jisyong Wang

Antenna Polarity & Test Distance: Horizontal at 3 m										
Frequency (MHz)	Emission Level (dBuV/m)	Read Level (dBuV)	Limit (dBuV/m)	Margin (dB)	Antenna Factor (dB/m)	Cable Loss (dB)	Preamp Factor (dB)	Antenna Height (cm)	Table Angle (Degree)	Remark
5459.76	43.31	42.11	54	-9.95	31.77	6.51	37.08	167	355	Average
5459.76	57.82	56.62	74	-15.09	31.77	6.51	37.08	167	355	Peak
*5470	67.06	65.83	68.2	-1.14	31.79	6.52	37.08	167	355	Peak
5510	89.39	88.09			31.81	6.55	37.06	167	355	Average
5510	99.39	98.09			31.81	6.55	37.06	167	355	Peak
*5725	51.69	50.18	68.2	-16.51	32.18	6.76	37.43	167	355	Peak
11020	51.16	52.99	54	-4.67	40.71	10.41	52.95	125	236	Average
11020	61.7	63.53	74	-14.67	40.71	10.41	52.95	125	236	Peak

Antenna Polarity & Test Distance: Vertical at 3 m										
Frequency (MHz)	Emission Level (dBuV/m)	Read Level (dBuV)	Limit (dBuV/m)	Margin (dB)	Antenna Factor (dB/m)	Cable Loss (dB)	Preamp Factor (dB)	Antenna Height (cm)	Table Angle (Degree)	Remark
5459.6	40.76	39.56	54	-13.83	31.77	6.51	37.08	161	57	Average
5459.6	52.48	51.28	74	-20.26	31.77	6.51	37.08	161	57	Peak
*5470	62.38	61.15	68.2	-5.82	31.79	6.52	37.08	161	57	Peak
5510	86.04	84.74			31.81	6.55	37.06	161	57	Average
5510	96.05	94.75			31.81	6.55	37.06	161	57	Peak
*5725	51.33	49.82	68.2	-16.87	32.18	6.76	37.43	161	57	Peak
11020	49.43	51.26	54	-6.27	40.71	10.41	52.95	256	181	Average
11020	59.41	61.24	74	-16.21	40.71	10.41	52.95	256	181	Peak

Remarks:

- Emission Level = Read Level + Antenna Factor + Cable Loss - Preamp Factor  
Margin value = Emission level – Limit value
- 5510 MHz: Fundamental Frequency
- \*: Out of Restricted Band

EUT Test Condition		Measurement Detail	
Channel	Channel 110	Frequency Range	1 GHz ~ 40 GHz
Input Power	120 Vac, 60 Hz	Detector Function	Peak (PK) Average (AV)
Environmental Conditions	25 deg. C, 65 % RH	Tested By	Jisyong Wang

Antenna Polarity & Test Distance: Horizontal at 3 m										
Frequency (MHz)	Emission Level (dBuV/m)	Read Level (dBuV)	Limit (dBuV/m)	Margin (dB)	Antenna Factor (dB/m)	Cable Loss (dB)	Preamp Factor (dB)	Antenna Height (cm)	Table Angle (Degree)	Remark
5459.28	44.93	43.73	54	-9.95	31.77	6.51	37.08	165	2	Average
5459.28	58.24	57.04	74	-15.09	31.77	6.51	37.08	165	2	Peak
*5470	64.2	62.97	68.2	-4	31.79	6.52	37.08	165	2	Peak
5550	95.33	93.92			31.89	6.61	37.09	165	2	Average
5550	105.32	103.91			31.89	6.61	37.09	165	2	Peak
*5725	50.77	49.26	68.2	-17.43	32.18	6.76	37.43	165	2	Peak
11100	46.91	48.52	54	-4.67	40.63	10.47	52.71	125	236	Average
11100	57.02	58.63	74	-14.67	40.63	10.47	52.71	125	236	Peak

Antenna Polarity & Test Distance: Vertical at 3 m										
Frequency (MHz)	Emission Level (dBuV/m)	Read Level (dBuV)	Limit (dBuV/m)	Margin (dB)	Antenna Factor (dB/m)	Cable Loss (dB)	Preamp Factor (dB)	Antenna Height (cm)	Table Angle (Degree)	Remark
5459.44	41.16	39.96	54	-13.83	31.77	6.51	37.08	161	56	Average
5459.44	53.88	52.68	74	-20.26	31.77	6.51	37.08	161	56	Peak
*5470	56.05	54.82	68.2	-12.15	31.79	6.52	37.08	161	56	Peak
5550	90.87	89.46			31.89	6.61	37.09	161	56	Average
5550	100.83	99.42			31.89	6.61	37.09	161	56	Peak
*5725	51.38	49.87	68.2	-16.82	32.18	6.76	37.43	161	56	Peak
11100	44.91	46.52	54	-6.27	40.63	10.47	52.71	256	213	Average
11100	55.07	56.68	74	-16.21	40.63	10.47	52.71	256	213	Peak

Remarks:

- Emission Level = Read Level + Antenna Factor + Cable Loss - Preamp Factor  
Margin value = Emission level – Limit value
- 5550 MHz: Fundamental Frequency
- \*: Out of Restricted Band

EUT Test Condition		Measurement Detail	
Channel	Channel 134	Frequency Range	1 GHz ~ 40 GHz
Input Power	120 Vac, 60 Hz	Detector Function	Peak (PK) Average (AV)
Environmental Conditions	25 deg. C, 65 % RH	Tested By	Jisyong Wang

Antenna Polarity & Test Distance: Horizontal at 3 m										
Frequency (MHz)	Emission Level (dBuV/m)	Read Level (dBuV)	Limit (dBuV/m)	Margin (dB)	Antenna Factor (dB/m)	Cable Loss (dB)	Preamp Factor (dB)	Antenna Height (cm)	Table Angle (Degree)	Remark
5410	38.78	37.74	54	-9.95	31.74	6.48	37.18	178	18	Average
5410	50.39	49.35	74	-15.09	31.74	6.48	37.18	178	18	Peak
*5470	50.26	49.03	68.2	-17.94	31.79	6.52	37.08	178	18	Peak
5670	92.37	90.9			32.09	6.72	37.34	178	18	Average
5670	102.33	100.86			32.09	6.72	37.34	178	18	Peak
*5725	67	65.49	68.2	-1.2	32.18	6.76	37.43	178	18	Peak
11340	47.85	49.65	54	-4.67	40.4	10.52	52.72	125	236	Average
11340	58.16	59.96	74	-14.67	40.4	10.52	52.72	125	236	Peak

Antenna Polarity & Test Distance: Vertical at 3 m										
Frequency (MHz)	Emission Level (dBuV/m)	Read Level (dBuV)	Limit (dBuV/m)	Margin (dB)	Antenna Factor (dB/m)	Cable Loss (dB)	Preamp Factor (dB)	Antenna Height (cm)	Table Angle (Degree)	Remark
5426.8	38.9	37.79	54	-13.83	31.75	6.49	37.13	151	55	Average
5426.8	51.55	50.44	74	-20.26	31.75	6.49	37.13	151	55	Peak
*5470	49.91	48.68	68.2	-18.29	31.79	6.52	37.08	151	55	Peak
5670	87.54	86.07			32.09	6.72	37.34	151	55	Average
5670	97.54	96.07			32.09	6.72	37.34	151	55	Peak
*5725	63.9	24.96	68.2	-4.3	32.18	6.76	0	151	55	Peak
11340	46.83	48.63	54	-6.27	40.4	10.52	52.72	236	111	Average
11340	56.77	58.57	74	-16.21	40.4	10.52	52.72	236	111	Peak

Remarks:

- Emission Level = Read Level + Antenna Factor + Cable Loss - Preamp Factor  
Margin value = Emission level – Limit value
- 5670 MHz: Fundamental Frequency
- \*: Out of Restricted Band

EUT Test Condition		Measurement Detail	
Channel	Channel 151	Frequency Range	1 GHz ~ 40 GHz
Input Power	120 Vac, 60 Hz	Detector Function	Peak (PK) Average (AV)
Environmental Conditions	25 deg. C, 65 % RH	Tested By	Jisyong Wang

### <Spurious Emission>

Antenna Polarity & Test Distance: Horizontal at 3 m										
Frequency (MHz)	Emission Level (dBuV/m)	Read Level (dBuV)	Limit (dBuV/m)	Margin (dB)	Antenna Factor (dB/m)	Cable Loss (dB)	Preamp Factor (dB)	Antenna Height (cm)	Table Angle (Degree)	Remark
5755	89.82	88.27			32.23	6.79	37.47	178	310	Average
5755	99.87	98.32			32.23	6.79	37.47	178	310	Peak
11510	48.14	50.03	54	-5.86	40.23	10.69	52.81	201	189	Average
11510	58.14	60.03	74	-15.86	40.23	10.69	52.81	201	189	Peak
Antenna Polarity & Test Distance: Vertical at 3 m										
Frequency (MHz)	Emission Level (dBuV/m)	Read Level (dBuV)	Limit (dBuV/m)	Margin (dB)	Antenna Factor (dB/m)	Cable Loss (dB)	Preamp Factor (dB)	Antenna Height (cm)	Table Angle (Degree)	Remark
5755	89.92	88.37			32.23	6.79	37.47	198	161	Average
5755	99.99	98.44			32.23	6.79	37.47	198	161	Peak
11510	47.17	49.06	54	-6.83	40.23	10.69	52.81	111	165	Average
11510	57.17	59.06	74	-16.83	40.23	10.69	52.81	111	165	Peak

### <Out of Band Emission (OOBE)>

Antenna Polarity & Test Distance: Horizontal at 3 m										
Frequency (MHz)	Emission Level (dBuV/m)	Read Level (dBuV)	Limit (dBuV/m)	Margin (dB)	Antenna Factor (dB/m)	Cable Loss (dB)	Preamp Factor (dB)	Antenna Height (cm)	Table Angle (Degree)	Remark
5637.4	51.98	50.52	68.2	-16.22	32.04	6.7	37.28	178	310	Peak
5651.65	53.08	51.59	69.43	-16.35	32.06	6.71	37.28	178	310	Peak
5917.65	51.37	49.52	73.62	-22.25	32.49	6.86	37.5	178	310	Peak
5983.2	52.37	50.4	68.2	-15.83	32.6	6.88	37.51	178	310	Peak
Antenna Polarity & Test Distance: Vertical at 3 m										
Frequency (MHz)	Emission Level (dBuV/m)	Read Level (dBuV)	Limit (dBuV/m)	Margin (dB)	Antenna Factor (dB/m)	Cable Loss (dB)	Preamp Factor (dB)	Antenna Height (cm)	Table Angle (Degree)	Remark
5647.85	52.67	51.21	68.2	-15.53	32.04	6.7	37.28	198	161	Peak
5656.4	52.96	51.53	72.95	-19.99	32.06	6.71	37.34	198	161	Peak
5920.025	51.6	49.75	71.87	-20.27	32.49	6.86	37.5	198	161	Peak
5958.5	51.85	49.91	68.2	-16.35	32.57	6.87	37.5	198	161	Peak

#### Remarks:

- Emission Level = Read Level + Antenna Factor + Cable Loss - Preamp Factor  
Margin value = Emission level – Limit value
- 5755 MHz: Fundamental Frequency
- \*: Out of Restricted Band



EUT Test Condition		Measurement Detail	
Channel	Channel 159	Frequency Range	1 GHz ~ 40 GHz
Input Power	120 Vac, 60 Hz	Detector Function	Peak (PK) Average (AV)
Environmental Conditions	25 deg. C, 65 % RH	Tested By	Jisyong Wang

<Spurious Emission>

Antenna Polarity & Test Distance: Horizontal at 3 m										
Frequency (MHz)	Emission Level (dBuV/m)	Read Level (dBuV)	Limit (dBuV/m)	Margin (dB)	Antenna Factor (dB/m)	Cable Loss (dB)	Preamp Factor (dB)	Antenna Height (cm)	Table Angle (Degree)	Remark
5795	88.19	86.61			32.29	6.83	37.54	176	289	Average
5795	98.19	96.61			32.29	6.83	37.54	176	289	Peak
11590	46.57	48.69	54	-7.43	40.11	10.78	53.01	165	231	Average
11590	56.64	58.76	74	-17.36	40.11	10.78	53.01	165	231	Peak
Antenna Polarity & Test Distance: Vertical at 3 m										
Frequency (MHz)	Emission Level (dBuV/m)	Read Level (dBuV)	Limit (dBuV/m)	Margin (dB)	Antenna Factor (dB/m)	Cable Loss (dB)	Preamp Factor (dB)	Antenna Height (cm)	Table Angle (Degree)	Remark
5795	89.93	88.35			32.29	6.83	37.54	180	156	Average
5795	99.99	98.41			32.29	6.83	37.54	180	156	Peak
11590	47.01	49.13	54	-6.99	40.11	10.78	53.01	152	236	Average
11590	57.03	59.15	74	-16.97	40.11	10.78	53.01	152	236	Peak

<Out of Band Emission (OOBE)>

Antenna Polarity & Test Distance: Horizontal at 3 m										
Frequency (MHz)	Emission Level (dBuV/m)	Read Level (dBuV)	Limit (dBuV/m)	Margin (dB)	Antenna Factor (dB/m)	Cable Loss (dB)	Preamp Factor (dB)	Antenna Height (cm)	Table Angle (Degree)	Remark
5595.125	51.88	50.42	68.2	-16.32	31.95	6.67	37.16	176	289	Peak
5650.7	51.45	49.96	68.72	-17.27	32.06	6.71	37.28	176	289	Peak
5919.075	50.95	49.1	72.57	-21.62	32.49	6.86	37.5	176	289	Peak
5933.325	52.59	50.71	68.2	-15.61	32.52	6.86	37.5	176	289	Peak
Antenna Polarity & Test Distance: Vertical at 3 m										
Frequency (MHz)	Emission Level (dBuV/m)	Read Level (dBuV)	Limit (dBuV/m)	Margin (dB)	Antenna Factor (dB/m)	Cable Loss (dB)	Preamp Factor (dB)	Antenna Height (cm)	Table Angle (Degree)	Remark
5644.525	51.19	49.73	68.2	-17.01	32.04	6.7	37.28	180	156	Peak
5656.875	51.09	49.66	73.31	-22.22	32.06	6.71	37.34	180	156	Peak
5919.55	51.75	49.9	72.22	-20.47	32.49	6.86	37.5	180	156	Peak
5928.1	52.49	50.61	68.2	-15.71	32.52	6.86	37.5	180	156	Peak

Remarks:

- Emission Level = Read Level + Antenna Factor + Cable Loss - Preamp Factor  
Margin value = Emission level – Limit value
- 5795 MHz: Fundamental Frequency
- \*: Out of Restricted Band

**9 kHz ~ 30 MHz Data:**

The amplitude of spurious emissions attenuated more than 20 dB below the permissible value is not required to be report.

**30 MHz ~ 1 GHz Worst-Case Data:**

**802.11n (HT40)**

EUT Test Condition		Measurement Detail	
Channel	Channel 102	Frequency Range	30 MHz ~ 1 GHz
Input Power	120 Vac, 60 Hz	Detector Function	Peak (PK) Quasi-peak (QP)
Environmental Conditions	25 deg. C, 65 % RH	Tested By	Jisyoung Wang

Antenna Polarity & Test Distance: Horizontal at 3 m										
Frequency (MHz)	Emission Level (dBuV/m)	Read Level (dBuV)	Limit (dBuV/m)	Margin (dB)	Antenna Factor (dB/m)	Cable Loss (dB)	Preamp Factor (dB)	Antenna Height (cm)	Table Angle (Degree)	Remark
51.34	21.71	39.61	40	-18.29	12.87	0.54	31.31	201	256	Peak
94.02	22.91	45.54	43.5	-20.59	8.6	0.73	31.96	111	132	Peak
165.8	29.87	48.46	43.5	-13.63	12.15	1.05	31.79	111	162	Peak
384.05	26.1	41.11	46	-19.9	14.96	2.02	31.99	203	256	Peak
669.23	24.78	32.99	46	-21.22	20.44	3.17	31.82	311	123	Peak
953.44	28.85	32.66	46	-17.15	23.81	4.24	31.86	165	123	Peak
Antenna Polarity & Test Distance: Vertical at 3 m										
Frequency (MHz)	Emission Level (dBuV/m)	Read Level (dBuV)	Limit (dBuV/m)	Margin (dB)	Antenna Factor (dB/m)	Cable Loss (dB)	Preamp Factor (dB)	Antenna Height (cm)	Table Angle (Degree)	Remark
37.76	34.72	52.02	40	-5.28	13.24	0.48	31.02	111	185	Peak
93.05	19.5	42.21	43.5	-24	8.53	0.72	31.96	102	236	Peak
306.45	18.02	35.15	46	-27.98	13.1	1.68	31.91	111	145	Peak
491.72	24	36.12	46	-22	17.16	2.46	31.74	111	132	Peak
768.17	29.54	35.52	46	-16.46	21.78	3.57	31.33	205	236	Peak
935.98	30.12	34.19	46	-15.88	23.71	4.17	31.95	111	132	Peak

Remarks:

- Emission Level = Read Level + Antenna Factor + Cable Loss - Preamp Factor  
Margin value = Emission level – Limit value

## 4.2 Conducted Emission Measurement

### 4.2.1 Limits of Conducted Emission Measurement

Frequency (MHz)	Conducted Limit (dBUV)	
	Quasi-peak	Average
0.15 - 0.5	66 - 56	56 - 46
0.50 - 5.0	56	46
5.0 - 30.0	60	50

- Note: 1. The lower limit shall apply at the transition frequencies.  
 2. The limit decreases in line with the logarithm of the frequency in the range of 0.15 to 0.50 MHz.

### 4.2.2 Test Instruments

Description & Manufacturer	Model No.	Serial No.	Date Of Calibration	Due Date Of Calibration
Test Receiver ROHDE & SCHWARZ	ESCI	100613	Nov. 23, 2017	Nov. 22, 2018
RF signal cable (with 10dB PAD) Woken	5D-FB	Cable-cond1-01	Sep. 05, 2017	Sep. 04, 2018
LISN/AMN ROHDE & SCHWARZ (EUT)	ESH3-Z5	835239/001	Mar. 10, 2017	Mar. 09, 2018
LISN/AMN ROHDE & SCHWARZ (Peripheral)	ESH3-Z5	100311	Aug. 15, 2017	Aug. 14, 2018
Software ADT	BV ADT_Cond_ V7.3.7.3	NA	NA	NA

- Note: 1. The calibration interval of the above test instruments is 12 months and the calibrations are traceable to NML/ROC and NIST/USA.  
 2. The test was performed in HwaYa Shielded Room 1.  
 3. The VCCI Site Registration No. is C-2040.

#### 4.2.3 Test Procedures

- a. The EUT was placed 0.4 meters from the conducting wall of the shielded room with EUT being connected to the power mains through a line impedance stabilization network (LISN). Other support units were connected to the power mains through another LISN. The two LISNs provide 50 ohm/ 50uH of coupling impedance for the measuring instrument.
- b. Both lines of the power mains connected to the EUT were checked for maximum conducted interference.
- c. The frequency range from 150 kHz to 30 MHz was searched. Emission levels under (Limit -20 dB) was not recorded.

**Note:** All modes of operation were investigated and the worst-case emissions are reported.

#### 4.2.4 Deviation from Test Standard

No deviation.

#### 4.2.5 Test Setup

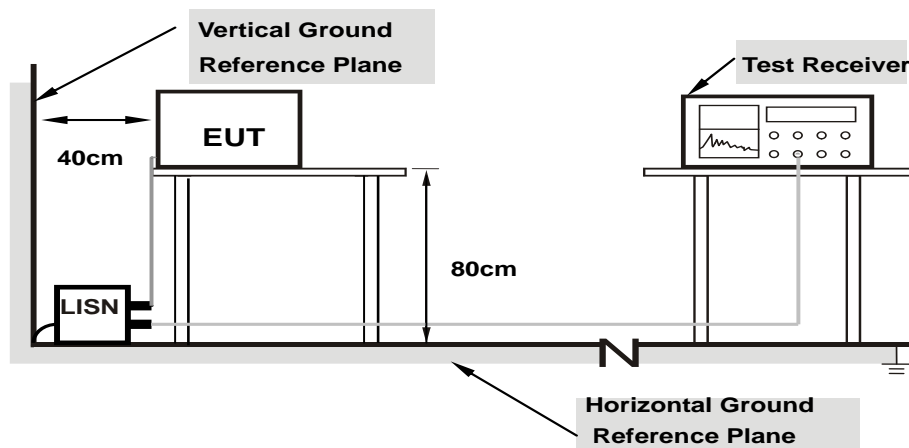

- Note:**
1. Support units were connected to second LISN.
  2. Both of LISNs (AMN) are 80 cm from EUT and at least 80 from other units and other metal planes

For the actual test configuration, please refer to the attached file (Test Setup Photo).

#### 4.2.6 EUT Operating Conditions

- a. Placed the EUT on a testing table.
- b. Use the software to control the EUT under transmission condition continuously at specific channel frequency.

#### 4.2.7 Test Results

Frequency Range	150kHz ~ 30MHz	Detector Function & Resolution Bandwidth	Quasi-Peak (QP) / Average (AV), 9kHz
Input Power	120Vac, 60Hz	Environmental Conditions	25°C, 65%RH
Tested by	Getaz Yang	Test Date	2018/2/5

Phase Of Power : Line (L)										
No	Frequency (MHz)	Correction Factor (dB)	Reading Value (dBuV)		Emission Level (dBuV)		Limit (dBuV)		Margin (dB)	
			Q.P.	AV.	Q.P.	AV.	Q.P.	AV.	Q.P.	AV.
1	0.17801	10.10	40.63	11.79	50.73	21.89	64.58	54.58	-13.85	-32.69
2	0.20201	10.10	47.09	25.42	57.19	35.52	63.53	53.53	-6.34	-18.01
3	0.29400	10.11	33.65	16.98	43.76	27.09	60.41	50.41	-16.65	-23.32
4	1.12200	10.15	27.72	15.46	37.87	25.61	56.00	46.00	-18.13	-20.39
5	5.57400	10.37	37.04	28.77	47.41	39.14	60.00	50.00	-12.59	-10.86
6	14.05400	10.86	38.34	28.99	49.20	39.85	60.00	50.00	-10.80	-10.15

Remarks:

1. Q.P. and AV. are abbreviations of quasi-peak and average individually.
2. The emission levels of other frequencies were very low against the limit.
3. Margin value = Emission level – Limit value
4. Correction factor = Insertion loss + Cable loss
5. Emission Level = Correction Factor + Reading Value

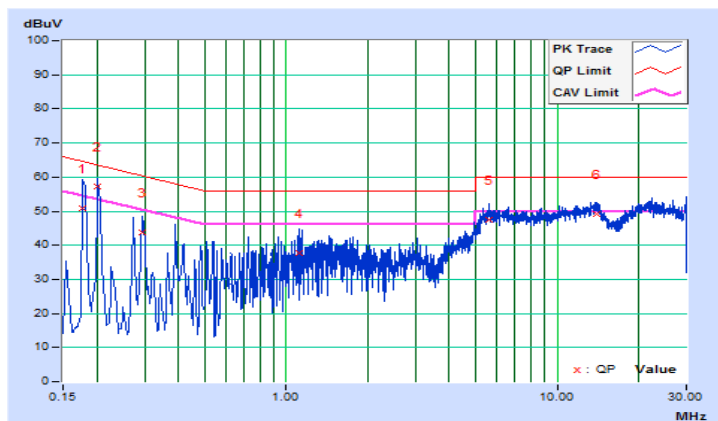

Frequency Range	150kHz ~ 30MHz	Detector Function & Resolution Bandwidth	Quasi-Peak (QP) / Average (AV), 9kHz
Input Power	120Vac, 60Hz	Environmental Conditions	25°C, 65%RH
Tested by	Getaz Yang	Test Date	2018/2/5

Phase Of Power : Neutral (N)										
No	Frequency (MHz)	Correction Factor (dB)	Reading Value (dBuV)		Emission Level (dBuV)		Limit (dBuV)		Margin (dB)	
			Q.P.	AV.	Q.P.	AV.	Q.P.	AV.	Q.P.	AV.
1	0.18200	10.10	32.83	14.95	42.93	25.05	64.39	54.39	-21.46	-29.34
2	0.46200	10.12	31.82	20.76	41.94	30.88	56.66	46.66	-14.72	-15.78
3	0.53404	10.12	35.06	21.30	45.18	31.42	56.00	46.00	-10.82	-14.58
4	1.96200	10.17	26.27	13.93	36.44	24.10	56.00	46.00	-19.56	-21.90
5	13.47000	10.67	36.98	23.99	47.65	34.66	60.00	50.00	-12.35	-15.34
6	21.78200	10.97	39.35	26.49	50.32	37.46	60.00	50.00	-9.68	-12.54

Remarks:

1. Q.P. and AV. are abbreviations of quasi-peak and average individually.
2. The emission levels of other frequencies were very low against the limit.
3. Margin value = Emission level – Limit value
4. Correction factor = Insertion loss + Cable loss
5. Emission Level = Correction Factor + Reading Value

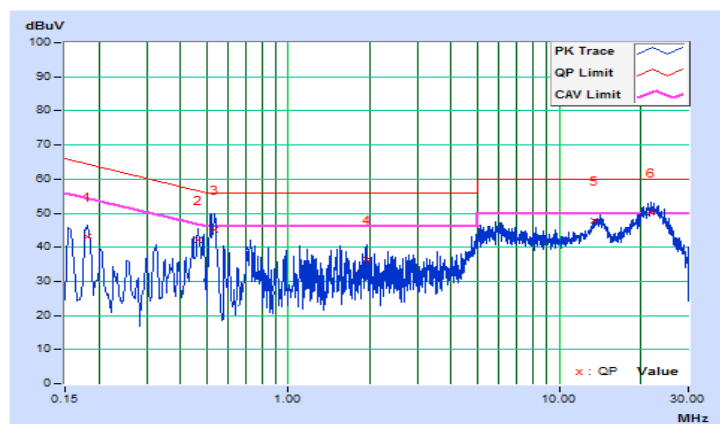

## 5 Pictures of Test Arrangements

Please refer to the attached file (Test Setup Photo).

## Appendix – Information on the Testing Laboratories

We, Bureau Veritas Consumer Products Services (H.K.) Ltd., Taoyuan Branch, were founded in 1988 to provide our best service in EMC, Radio, Telecom and Safety consultation. Our laboratories are FCC recognized accredited test firms and accredited according to ISO/IEC 17025.

If you have any comments, please feel free to contact us at the following:

**Linko EMC/RF Lab**

Tel: 886-2-26052180

Fax: 886-2-26051924

**Hsin Chu EMC/RF/Telecom Lab**

Tel: 886-3-6668565

Fax: 886-3-6668323

**Hwa Ya EMC/RF/Safety**

Tel: 886-3-3183232

Fax: 886-3-3270892

**Email:** [service.adt@tw.bureauveritas.com](mailto:service.adt@tw.bureauveritas.com)

**Web Site:** [www.bureauveritas-adt.com](http://www.bureauveritas-adt.com)

The address and road map of all our labs can be found in our web site also.

--- END ---